

City of Puyallup Development & Permitting Services ISSUED PERMIT	
Building	Planning
Engineering	Public Works
Fire	Traffic

# *Fire Systems West, Inc.*

206 FRONTAGE ROAD NORTH, SUITE C  
PACIFIC, WA 98047  
(253) 833-1248



## **FIRE SPRINKLER**

**Material Submittal**

FOR

*Goldfish*  
Puyallup, WA

FSW JOB NO. 2-11-12042

# **TABLE OF CONTENTS**

1. Tyco TY-FRB, Quick Response, Upright and Pendent Sprinklers
2. Tyco TY-FRB, Quick Response, 8.0K, Upright and Pendent Sprinklers
3. FlexHead Flexible Fire Sprinkler Drop

## Series TY-FRB, 5.6 K-factor Upright, Pendent, and Recessed Pendent Sprinklers Quick Response, Standard Coverage

### IMPORTANT

Refer to Technical Data Sheet TFP2300 for warnings pertaining to regulatory and health information.

Always refer to Technical Data Sheet TFP700 for the "INSTALLER WARNING" that provides cautions with respect to handling and installation of sprinkler systems and components. Improper handling and installation can permanently damage a sprinkler system or its components and cause the sprinkler to fail to operate in a fire situation or cause it to operate prematurely.

Scan the QR code or enter the URL in a web browser to access the most up-to-date electronic version of this document. Data rates may apply.



[docs.jci.com/tycofire/TFP172](http://docs.jci.com/tycofire/TFP172)

### General Description

The TYCO Series TY-FRB, 5.6 K-factor, Upright (TY313) and Pendent (TY323) Sprinklers described in this data sheet are quick response, standard coverage, decorative 3 mm glass bulb-type spray sprinklers designed for use in light or ordinary hazard, commercial occupancies such as banks, hotels, and shopping malls.

The recessed version of the Series TY-FRB Pendent Sprinkler, where applicable, is intended for use in areas

with a finished ceiling. This recessed pendent sprinkler uses one of the following:

- A two-piece Style 15 Recessed Escutcheon with recessed adjustment up to 5/8 in. (15,9 mm) from the flush pendent position.
- A two-piece Style 20 Recessed Escutcheon with recessed adjustment up to 1/2 in. (12,7 mm) from the flush pendent position.

The adjustment provided by the Recessed Escutcheon reduces the accuracy to which the fixed pipe drops to the sprinklers must be cut.

Intermediate level versions of Series TY-FRB Sprinklers are described in Technical Data Sheet TFP357. Sprinkler guards and shields are described in Technical Data Sheet TFP780.

### NOTICE

The TYCO Series TY-FRB Sprinklers described herein must be installed and maintained in compliance with this document, as well as with the applicable standards of the National Fire Protection Association, in addition to the standards of any other authorities having jurisdiction. Failure to do so may impair the performance of these devices.

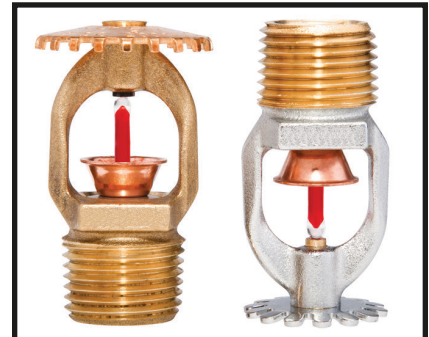
The owner is responsible for maintaining their fire protection system and devices in proper operating condition. Contact the installing contractor or product manufacturer with any questions.

### Sprinkler Identification Number (SIN)

TY313 . . . . Upright 5.6K, 1/2 in. NPT  
TY323 . . . . Pendent 5.6K, 1/2 in. NPT

### Technical Data

Approvals  
See Table A



**Maximum Working Pressure**  
175 psi (12.1 bar)  
250 psi (17.2 bar)\*

\* The maximum working pressure of 250 psi (17.2 bar) only applies to the listing by Underwriters Laboratories, Inc. (UL).

**Discharge Coefficient**  
K=5.6 GPM/psi<sup>1/2</sup> (80,6 LPM/bar<sup>1/2</sup>)

**Temperature Rating**  
See Table A

**Finishes**  
Sprinkler: See Table B

Recessed Escutcheon: White Coated, Black Coated, Chrome Plated, or Brass Plated

**Physical Characteristics**

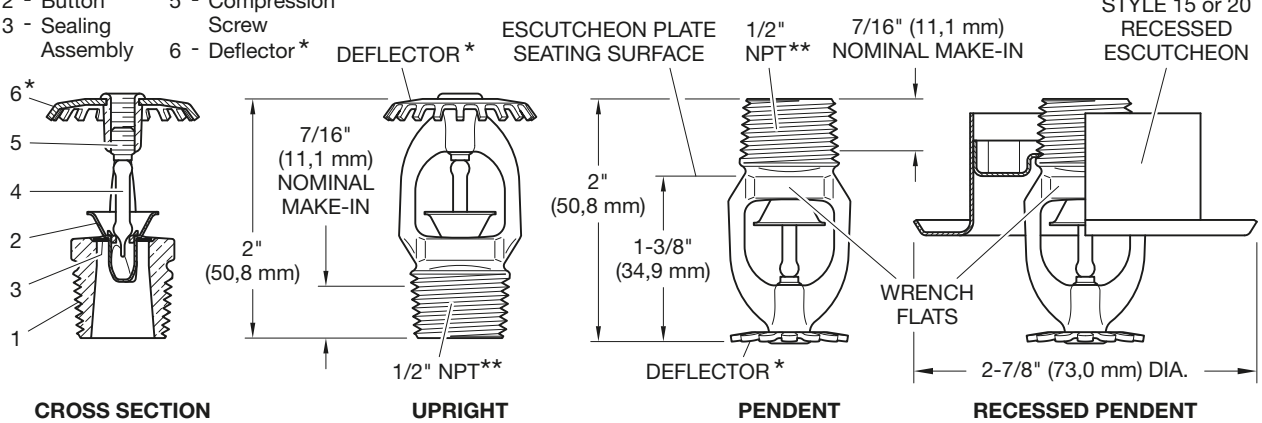
Frame . . . . .	Bronze
Button . . . . .	Brass/Copper
Sealing Assembly . . . . .	Stainless Steel w/TEFLON
Bulb . . . . .	Glass
Compression Screw . . . . .	Bronze
Deflector . . . . .	Bronze

Components:

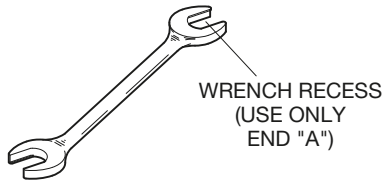
- 1 - Frame
- 2 - Button
- 3 - Sealing Assembly
- 4 - Bulb
- 5 - Compression Screw
- 6 - Deflector\*

\* Temperature rating is indicated on Deflector.

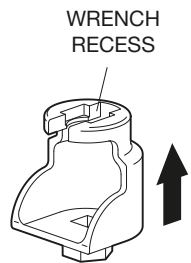
\*\* Pipe thread connections per ISO 7-1 can be provided on special request.



**FIGURE 1**  
**SERIES TY-FRB UPRIGHT (TY313) AND PENDENT (TY323) SPRINKLERS**  
**5.6 K-FACTOR, 1/2 INCH NPT, QUICK RESPONSE**

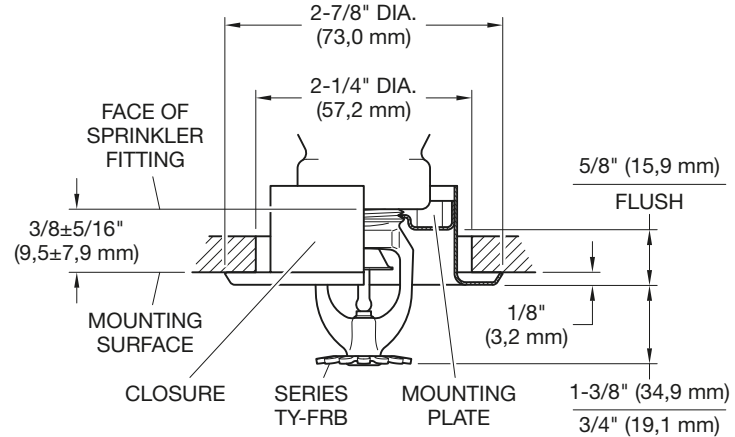


**FIGURE 2**  
**W-TYPE 6**  
**SPRINKLER WRENCH**

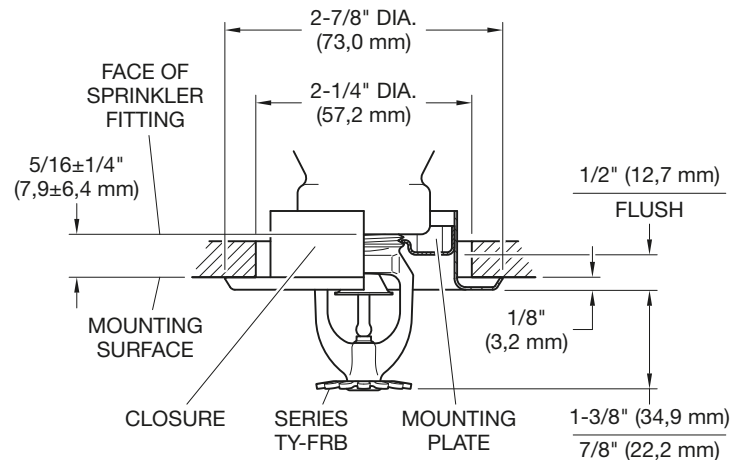


**FIGURE 3**  
**W-TYPE 7 RECESSED**  
**SPRINKLER WRENCH**

PUSH WRENCH IN TO ENSURE ENGAGEMENT WITH SPRINKLER WRENCHING AREA



**FIGURE 4**  
**SERIES TY-FRB RECESSED PENDENT SPRINKLER ASSEMBLY (TY323)**  
**WITH TWO PIECE 5/8 INCH TOTAL ADJUSTMENT STYLE 15**  
**RECESSED ESCUTCHEON**



**FIGURE 5**  
**SERIES TY-FRB RECESSED PENDENT SPRINKLER ASSEMBLY (TY323)**  
**WITH TWO PIECE 1/2 INCH TOTAL ADJUSTMENT STYLE 20**  
**RECESSED ESCUTCHEON**

K-Factor	Type	Temperature	Sprinkler Finish <sup>b</sup>		
			Bulb Liquid Color	Natural Brass	Chrome Plated
5.6 1/2 in. NPT	UPRIGHT (TY313) and PENDENT (TY323)	135°F (57°C)	Orange		1, 2, 3, 4, 5, 6, 7
		155°F (68°C)	Red		
		175°F (79°C)	Yellow		
		200°F (93°C)	Green		
		286°F (141°C)	Blue		
	RECESSED PENDENT (TY323) Figures 4 <sup>a</sup> and 5 <sup>b</sup>	135°F (57°C)	Orange		1, 2, 3, 4, 7
		155°F (68°C)	Red		
		175°F (79°C)	Yellow		
		200°F (93°C)	Green		

**Notes:**

1. Listed by Underwriters Laboratories, Inc., (UL) as Quick Response Sprinklers.
  2. Listed by Underwriters Laboratories, Inc., for use in Canada (C-UL) as Quick Response Sprinklers.
  3. Approved by Factory Mutual Research Corporation (FM) as Quick Response Sprinklers.
  4. Approved by the City of New York under MEA 354-01-E.
  5. VdS Approved (For details, contact Johnson Controls, Enschede, Netherlands, Tel. 31-53-428-4444/Fax 31-54-428-3377.)
  6. Approved by the Loss Prevention Certification Board (LPCB Ref. No. 094a/06) as Quick Response Sprinklers.
  7. EAC Approved.
  8. Where Polyester Coated Sprinklers are noted to be UL and C-UL Listed, the sprinklers are UL and C-UL Listed as Corrosion-Resistant Sprinklers.
- a. Installed with Style 15 (1/2 in. NPT) 5/8 in. Total Adjustment Recessed Escutcheon, as applicable.  
b. Installed with Style 20 (1/2 in. NPT) 1/2 in. Total Adjustment Recessed Escutcheon, as applicable.  
c. Frame and Deflector only. Listings and approvals apply to color (Special Order).

**TABLE A**  
**LABORATORY LISTINGS AND APPROVALS FOR**  
**5.6 K-FACTOR SPRINKLERS**

## Operation

The glass bulb contains a fluid which expands when exposed to heat. When the rated temperature is reached, the fluid expands sufficiently to shatter the glass bulb, allowing the sprinkler to activate and water to flow.

## Design Criteria

The TYCO Series TY-FRB, 5.6 K-factor, Upright (TY313) and Pendent (TY323) Sprinklers are intended for fire protection systems designed in accordance with the standard installation rules recognized by the applicable Listing or Approval agency (such as, UL Listing is based on the requirements of NFPA 13, and FM Approval is based on the requirements of FM's Loss Prevention Data Sheets). Only the Style 15 or Style 20 Recessed Escutcheon is to be used for recessed pendent installations.

## Installation

The TYCO Series TY-FRB, 5.6 K-factor, Upright (TY313) and Pendent (TY323) Sprinklers must be installed in accordance with this section.

### General Instructions

Do not install any bulb-type sprinkler if the bulb is cracked or there is a loss of liquid from the bulb. With the sprinkler held horizontally, a small air bubble should be present. The diameter of the air bubble is approximately 1/16 in. (1,6 mm) for the 135°F (57°C) and 3/32 in. (2,4 mm) for the 286°F (141°C) temperature ratings.

A leak-tight 1/2 in. NPT sprinkler joint should be obtained by applying a minimum to maximum torque of 7 to 14 lb-ft (9,5 to 19,0 N·m). Higher levels of torque can distort the sprinkler Inlet with consequent leakage or impairment of the sprinkler.

Do not attempt to compensate for insufficient adjustment in the Escutcheon Plate by under- or over-tightening the sprinkler. Re-adjust the position of the sprinkler fitting to suit.

### Upright and Pendent Sprinklers

The Series TY-FRB Upright and Pendent Sprinklers must be installed in accordance with the following instructions.

**Step 1.** Install Pendent sprinklers in the pendent position. Install upright sprinklers in the upright position.

**Step 2.** With pipe-thread sealant applied to the pipe threads, hand-tighten the sprinkler into the sprinkler fitting.

**Step 3.** Tighten the sprinkler into the sprinkler fitting using only the W-Type 6 Sprinkler Wrench as shown in Figure 2. Apply the W-Type 6 Sprinkler Wrench to the wrench flats as shown in Figure 1. Torque sprinklers 7 to 14 lb-ft (9,5 to 19,0 N·m).

### Recessed Pendent Sprinklers

The Series TY-FRB Recessed Pendent Sprinklers must be installed in accordance with the following instructions.

**Step A.** After installing the Style 15 or Style 20 Mounting Plate over the sprinkler threads, and with pipe-thread sealant applied to the pipe threads, hand-tighten the sprinkler into the sprinkler fitting.

**Step B.** Tighten the sprinkler into the sprinkler fitting using only the W-Type 7 Recessed Sprinkler Wrench as shown in Figure 3. Apply the W-Type 7 Recessed Sprinkler Wrench to the sprinkler wrench flats as shown in Figure 1. Torque sprinklers 7 to 14 lb-ft (9,5 to 19,0 N·m).

**Step C.** After ceiling installation and finishing, slide on the Style 15 or Style 20 Closure over the Series TY-FRB Sprinkler and push the Closure over the Mounting Plate until its flange comes in contact with the ceiling.

P/N<sup>a</sup> 77 - XXX - X - XXX

		SIN	SPRINKLER FINISH		TEMPERATURE RATINGS	
370	5.6K UPRIGHT (1/2 in.NPT)	TY313	1	NATURAL BRASS	135	135°F (57°C)
371	5.6K PENDENT (1/2 in.NPT)	TY323	3	PURE WHITE (RAL9010) <sup>a</sup> POLYESTER	155	155°F (68°C)
			4	SIGNAL WHITE (RAL9003) POLYESTER	175	175°F (79°C)
			5	JET BLACK (RAL9005) POLYESTER	200	200°F (93°C)
			9	CHROME PLATED	286	286°F (141°C)

**Notes:**  
a. Use suffix "I" for ISO 7-1 connection; for example, 77-370-4-175-I

**Notes:**  
a. Eastern Hemisphere sales only

**TABLE B**  
**SERIES TY-FRB UPRIGHT AND PENDENT SPRINKLERS**  
**PART NUMBER SELECTION**

## Care and Maintenance

The TYCO Series TY-FRB, 5.6 K-factor, Upright (TY313) and Pendent (TY323) Sprinklers must be maintained and serviced in accordance with this section.

Before closing a fire protection system main control valve for maintenance work on the fire protection system that it controls, obtain permission to shut down the affected fire protection systems from the proper authorities and notify all personnel who may be affected by this action.

Absence of the outer piece of an escutcheon, which is used to cover a clearance hole, can delay sprinkler operation in a fire situation.

The owner must assure that the sprinklers are not used for hanging any objects and that the sprinklers are only cleaned by means of gently dusting with a feather duster; otherwise, non-operation in the event of a fire or inadvertent operation may result.

Sprinklers which are found to be leaking or exhibiting visible signs of corrosion must be replaced.

Automatic sprinklers must never be painted, plated, coated, or otherwise altered after leaving the factory. Modified sprinklers must be replaced. Sprinklers that have been exposed to corrosive products of combustion, but have not operated, should be replaced if they cannot be completely cleaned by wiping the sprinkler with a cloth or by brushing it with a soft bristle brush.

Care must be exercised to avoid damage to the sprinklers before, during, and after installation. Sprinklers damaged by dropping, striking, wrench twist/slippage, or the like, must be replaced. Also, replace any sprinkler that has a cracked bulb or that has lost liquid from its bulb. (Ref. Installation Section.)

The owner is responsible for the inspection, testing, and maintenance of their fire protection system and devices in compliance with this document, as well as with the applicable standards of the National Fire Protection Association such as NFPA 25, in addition to the standards of any other authorities having jurisdiction. Contact the installing contractor or product manufacturer with any questions.

Automatic sprinkler systems are recommended to be inspected, tested, and maintained by a qualified Inspection Service in accordance with local requirements and/or national codes.

## Limited Warranty

For warranty terms and conditions, visit [www.tyco-fire.com](http://www.tyco-fire.com).

## Ordering Procedure

Contact your local distributor for availability. When placing an order, indicate the full product name and Part Number (P/N).

### Sprinkler Assemblies with NPT Thread Connections

Specify: Series TY-FRB Upright or Pendent (specify) Sprinkler, SIN (specify), K=5.6, Quick Response, (specify) temperature rating, (specify) finish, P/N (specify, refer to Table A).

### Recessed Escutcheon

Specify: Style 15 Recessed Escutcheon with (specify\*) finish, P/N (specify\*)

Specify: Style 20 Recessed Escutcheon with (specify\*) finish, P/N (specify\*)

\* Refer to Technical Data Sheet TFP770

### Sprinkler Wrench

Specify: W-Type 6 Sprinkler Wrench, P/N 56-000-6-387

Specify: W-Type 7 Sprinkler Wrench, P/N 56-850-4-001

## Series TY-FRB – 2.8, 4.2, 5.6, and 8.0 K-Factor Upright, Pendent, and Recessed Pendent Sprinklers Quick Response, Standard Coverage

### IMPORTANT

Refer to Technical Data Sheet TFP2300 for warnings pertaining to regulatory and health information.

Always refer to Technical Data Sheet TFP700 for the “INSTALLER WARNING” that provides cautions with respect to handling and installation of sprinkler systems and components. Improper handling and installation can permanently damage a sprinkler system or its components and cause the sprinkler to fail to operate in a fire situation or cause it to operate prematurely.

Scan the QR code or enter the URL in a web browser to access the most up-to-date electronic version of this document. Data rates may apply.



[docs.jci.com/tycofire/TFP171](http://docs.jci.com/tycofire/TFP171)

## General Description

The TYCO Series TY-FRB 2.8, 4.2, 5.6, and 8.0 K-factor Upright, Pendent, and Recessed Pendent Sprinklers described in herein are quick response, standard coverage, decorative 3 mm glass bulb-type spray sprinklers. They are designed for use in light or ordinary hazard, commercial occupancies such as banks, hotels, and shopping malls.

The TY-FRB Recessed Pendent Sprinkler, where applicable, is intended for

use in areas with a finished ceiling. This recessed pendent sprinkler uses one of the following Recessed Escutcheons:

- A two-piece Style 10 (1/2 in. NPT) or Style 40 (3/4 in. NPT) Recessed Escutcheon with 1/2 in. (12,7 mm) of recessed adjustment or up to 3/4 in. (19,1 mm) of total adjustment from the flush pendent position.
- A two-piece Style 20 (1/2 in. NPT) or Style 30 (3/4 in. NPT) Recessed Escutcheon with 1/4 in. (6,4 mm) of recessed adjustment or up to 1/2 in. (12,7 mm) of total adjustment from the flush pendent position.

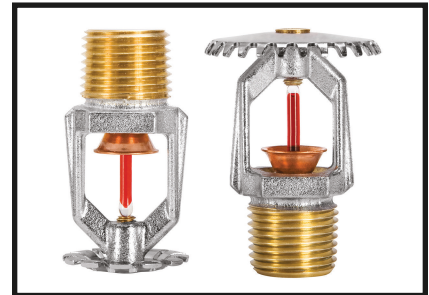
The adjustment provided by the Recessed Escutcheon reduces the accuracy to which the fixed pipe drops to the sprinklers must be cut.

Corrosion-resistant coatings, where applicable, are utilized to extend the life of copper alloy sprinklers beyond what would be obtained when exposed to corrosive atmospheres. Although corrosion-resistant coated sprinklers have passed the standard corrosion tests of the applicable approval agencies, the testing is not representative of all possible corrosive atmospheres. Consequently, it is recommended that the end user be consulted with respect to the suitability of these coatings for any given corrosive environment. The effects of ambient temperature, concentration of chemicals, and gas/chemical velocity, should be considered, as a minimum, along with the corrosive nature of the chemical to which the sprinklers will be exposed.

An intermediate level version of the Series TY-FRB Pendent Sprinklers is detailed in Technical Data Sheet TFP356. Sprinkler Guards are detailed in Technical Data Sheet TFP780.

### NOTICE

The Series TY-FRB 2.8, 4.2, 5.6, and 8.0 K-factor Upright, Pendent, and Recessed Pendent Sprinklers described herein must be installed and maintained in compliance with this document and with the applicable standards of the National Fire Protection Association (NFPA), in addition to



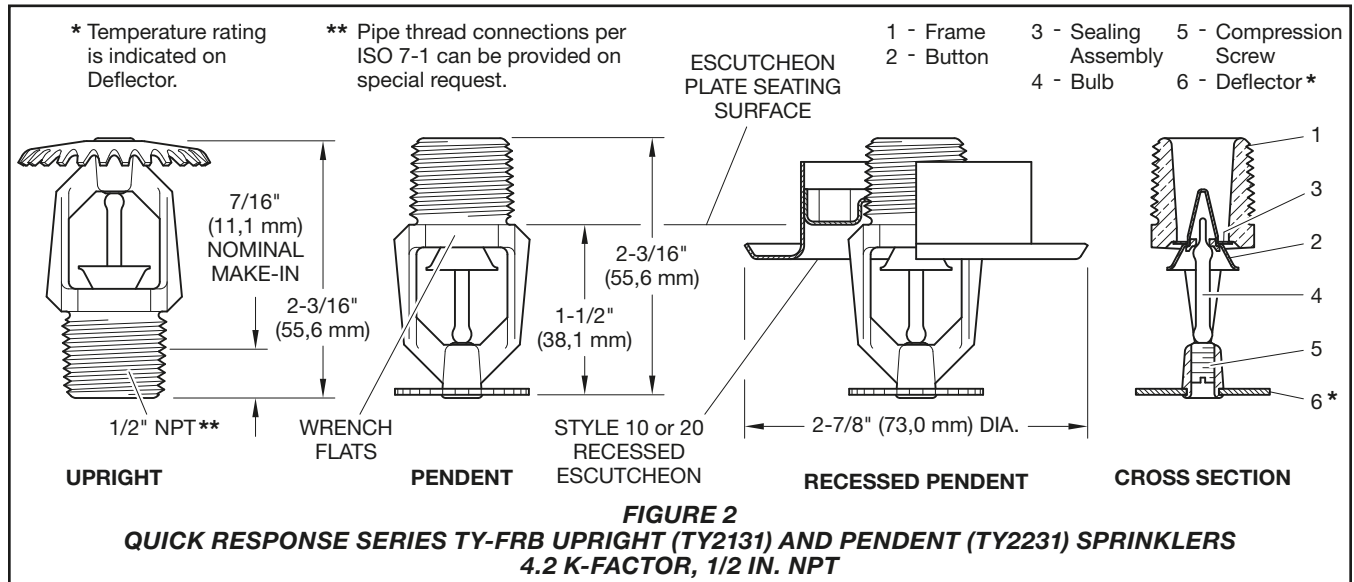
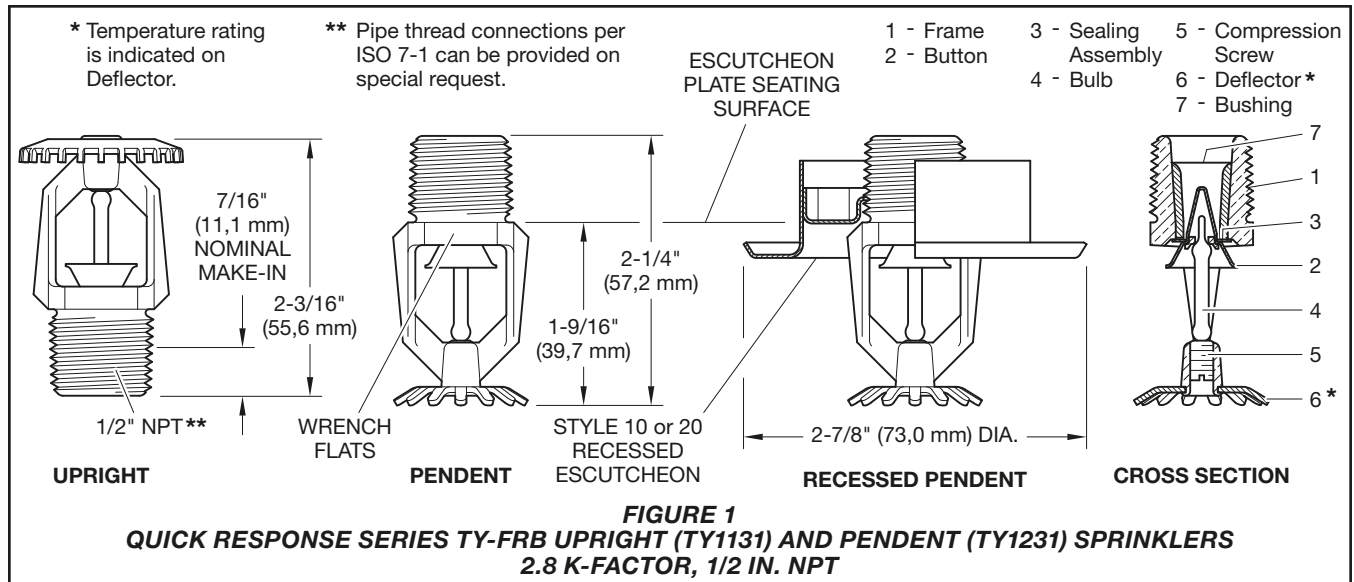
the standards of any authorities having jurisdiction. Failure to do so may impair the performance of these devices.

The owner is responsible for maintaining their fire protection system and devices in proper operating condition. The installing contractor or sprinkler manufacturer should be contacted with any questions.

NFPA 13 prohibits installation of 1/2 in. NPT sprinklers with K-factors greater than 5.6 in new construction. They are intended for retrofit in existing sprinkler systems only.

## Sprinkler Identification Number (SIN)

- ~~TY1131 . . . Upright 2.8K, 1/2 in. NPT~~
- ~~TY1231 . . . Pendent 2.8K, 1/2 in. NPT~~
- ~~TY2131 . . . Upright 4.2K, 1/2 in. NPT~~
- ~~TY2231 . . . Pendent 4.2K, 1/2 in. NPT~~
- ~~TY3131 . . . Upright 5.6K, 1/2 in. NPT~~
- ~~TY3231 . . . Pendent 5.6K, 1/2 in. NPT~~
- ~~TY4131 . . . Upright 8.0K, 3/4 in. NPT~~
- ~~TY4231 . . . Pendent 8.0K, 3/4 in. NPT~~
- ~~TY4831 . . . Upright 8.0K, 1/2 in. NPT~~
- ~~TY4931 . . . Pendent 8.0K, 1/2 in. NPT~~



## Technical Data

### Approvals

UL and C-UL Listed  
 FM, LPCB, and NYC Approved  
 EAC Approved

**Note:** For complete approval information, including corrosion-resistant status, see Tables A, B, C and D.

### Maximum Working Pressure

See Table E

### Discharge Coefficient

K=2.8 GPM/psi<sup>1/2</sup> (40,3 LPM/bar<sup>1/2</sup>)  
 K=4.2 GPM/psi<sup>1/2</sup> (60,5 LPM/bar<sup>1/2</sup>)  
 K=5.6 GPM/psi<sup>1/2</sup> (80,6 LPM/bar<sup>1/2</sup>)  
 K=8.0 GPM/psi<sup>1/2</sup> (115,2 LPM/bar<sup>1/2</sup>)

### Temperature Rating

See Tables A and B

### Finishes

Sprinkler: See Table D

Recessed Escutcheon: Signal or Pure White, Grey Aluminum, Jet Black, Chrome Plated, or Natural Brass

### Physical Characteristics

Frame ..... Bronze  
 Button ..... Brass/Copper  
 Sealing Assembly . . . Beryllium Nickel w/TEFLON  
 Bulb ..... Glass  
 Compression Screw ..... Bronze  
 Deflector ..... Copper/Bronze  
 Bushing (K=2.8) ..... Bronze

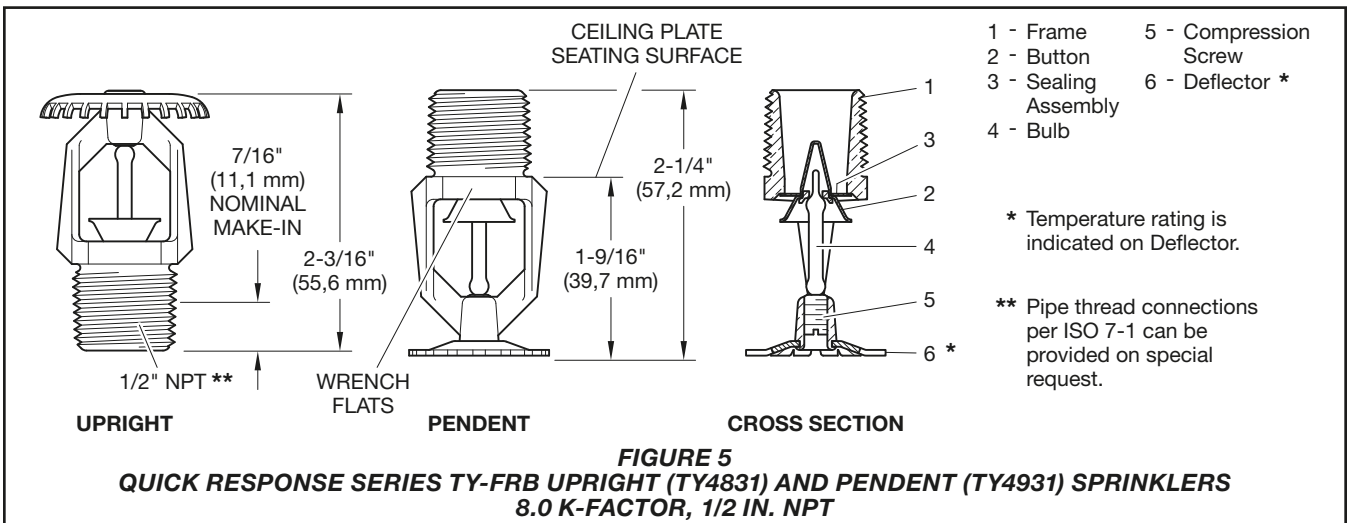
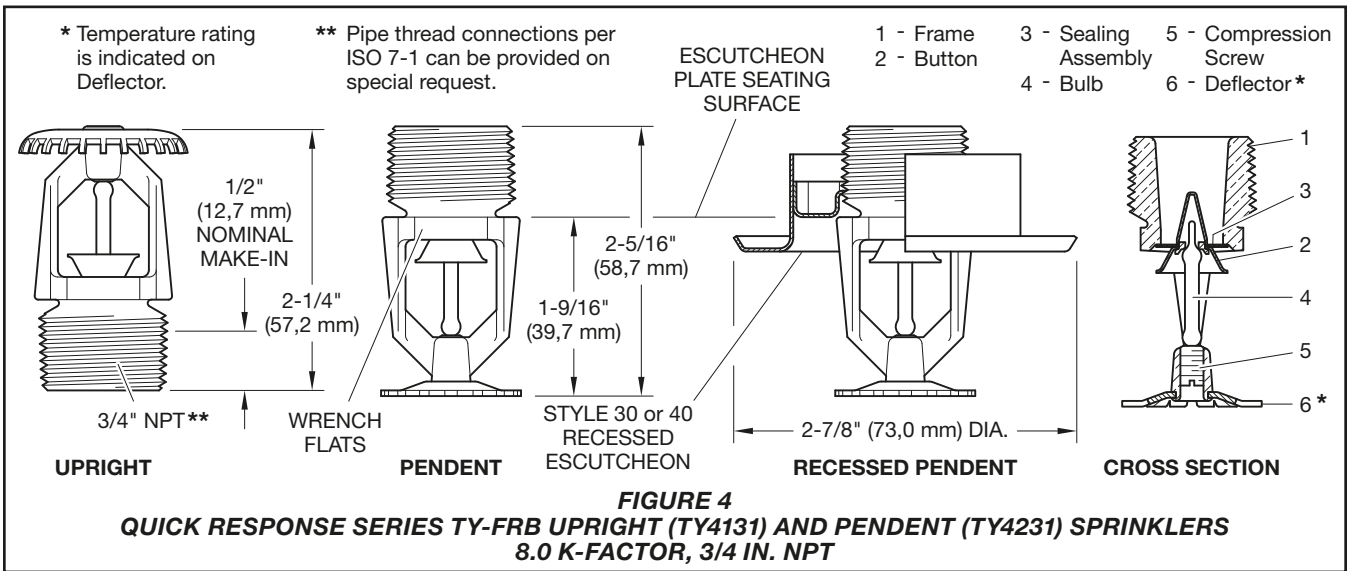
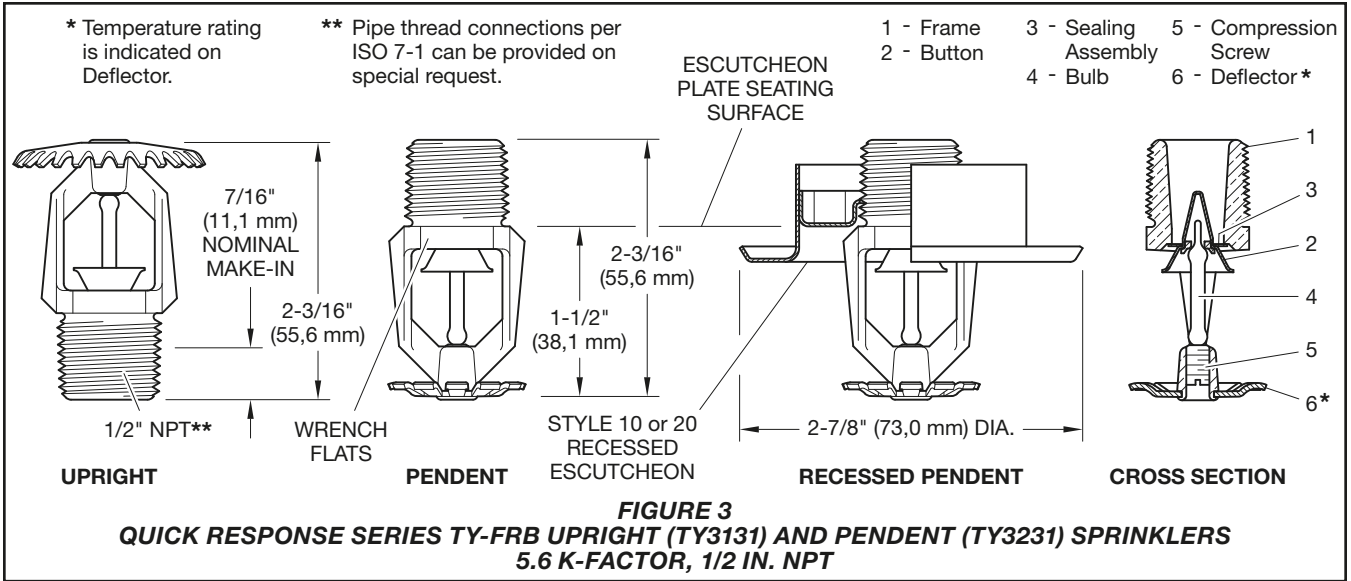
## Operation

The glass bulb contains a fluid that expands when exposed to heat. When the rated temperature is reached, the fluid expands sufficiently to shatter the glass bulb, allowing the sprinkler to activate and water to flow.

## Design Criteria

The TYCO Series TY-FRB 2.8, 4.2, 5.6, and 8.0 K-factor Upright, Pendent, and Recessed Pendent Sprinklers are intended for fire protection systems designed in accordance with the standard installation rules recognized by the applicable Listing or Approval agency, such as UL Listing based on the requirements of NFPA 13 and FM Approval based on the requirements of the FM Global Loss Prevention Data Sheets. Use only the style 10, 20, 30, or 40 Recessed Escutcheon, as applicable, for recessed pendent installations.





## **Installation**

The TYCO Series TY-FRB 2.8, 4.2, 5.6, and 8.0 K-factor Upright, Pendent, and Recessed Pendent Sprinklers must be installed in accordance with this section.

### **General Instructions**

Do not install any bulb type sprinkler if the bulb is cracked or there is a loss of liquid from the bulb. With the sprinkler held horizontally, a small air bubble should be present. The diameter of the air bubble is approximately 1/16 in. (1,6 mm) for the 135°F (57°C) and 3/32 in. (2,4 mm) for the 286°F (141°C) temperature ratings. A leak-tight 1/2 in. NPT sprinkler joint should be obtained by applying a minimum-to-maximum torque of 7 to 14 lb-ft (9,5 to 19,0 N-m). A leak tight 3/4 in. NPT sprinkler joint should be obtained with a torque of 10 to 20 lb-ft (13,4 to 26,8 N-m). Higher levels of torque can distort the sprinkler inlet and cause leakage or impairment of the sprinkler. Do not attempt to compensate for insufficient adjustment in the escutcheon plate by under- or over-tightening the sprinkler. Re-adjust the position of the sprinkler fitting to suit.

### **Series TY-FRB Upright and Pendent Sprinklers**

The Series TY-FRB Upright and Pendent Sprinklers must be installed in accordance with the following instructions:

**Step 1.** Install pendent sprinklers in the pendent position. Install upright sprinklers in the upright position.

**Step 2.** With pipe thread sealant applied to the pipe threads, hand-tighten the sprinkler into the sprinkler fitting.

**Step 3.** Tighten the sprinkler into the sprinkler fitting using only the W-Type 6 Sprinkler Wrench (Ref. Figure 14). With reference to Figure 1 to Figure 5, apply the W-Type 6 Sprinkler Wrench to the sprinkler wrench flats.

### **Series TY-FRB Recessed Pendent Sprinklers**

The Series TY-FRB Recessed Pendent Sprinklers must be installed in accordance with the following instructions:

**Step 1.** After installing the Style 10, 20, 30, or 40 Mounting Plate, as applicable, over the sprinkler threads and with pipe-thread sealant applied to the pipe threads, hand-tighten the sprinkler into the sprinkler fitting.

**Step 2.** Tighten the sprinkler into the sprinkler fitting using only the W-Type 7 Recessed Sprinkler Wrench, see Figure 15. With reference to Figure 1 to 4, apply the W-Type 7 Recessed Sprinkler Wrench to the sprinkler wrench flats.

**Step 3.** After the ceiling is installed or the finish coat is applied, slide on the Style 10, 20, 30, or 40 Closure over the Series TY-FRB Recessed Pendent Sprinkler and push the Closure over the Mounting Plate until its flange comes in contact with the ceiling.

## **Care and Maintenance**

The TYCO Series TY-FRB 2.8, 4.2, 5.6, and 8.0 K-factor Upright, Pendent, and Recessed Pendent Sprinklers must be maintained and serviced in accordance with this section. Before closing a fire protection system main control valve for maintenance work on the fire protection system that it controls, obtain permission to shut down the affected fire protection systems from the proper authorities and notify all personnel who may be affected by this action.

Absence of the outer piece of an escutcheon, which is used to cover a clearance hole, can delay sprinkler operation in a fire situation.

Sprinklers which are found to be leaking or exhibiting visible signs of corrosion must be replaced.

Automatic sprinklers must never be painted, plated, coated, or otherwise altered after leaving the factory. Modified sprinklers must be replaced. Sprinklers that have been exposed to

corrosive products of combustion, but have not operated, should be replaced if they cannot be completely cleaned by wiping the sprinkler with a cloth or by brushing it with a soft bristle brush.

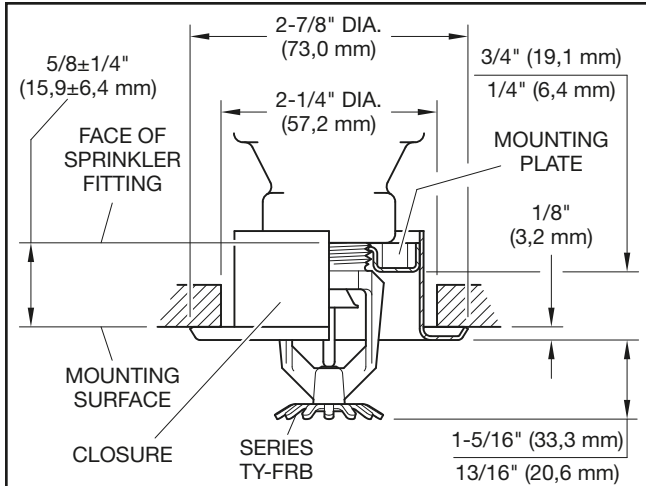
Care must be taken to avoid damage to the sprinklers before, during, and after installation. Sprinklers damaged by dropping, striking, wrench twist/slippage, or the like, must be replaced. Also, replace any sprinkler that has a cracked bulb or that has lost liquid from its bulb. For more information, see Installation section.

The owner is responsible for the inspection, testing, and maintenance of their fire protection system and devices in compliance with this document, as well as with the applicable standards of the National Fire Protection Association such as NFPA 25, in addition to the standards of any other authorities having jurisdiction. Contact the installing contractor or sprinkler manufacturer regarding any questions.

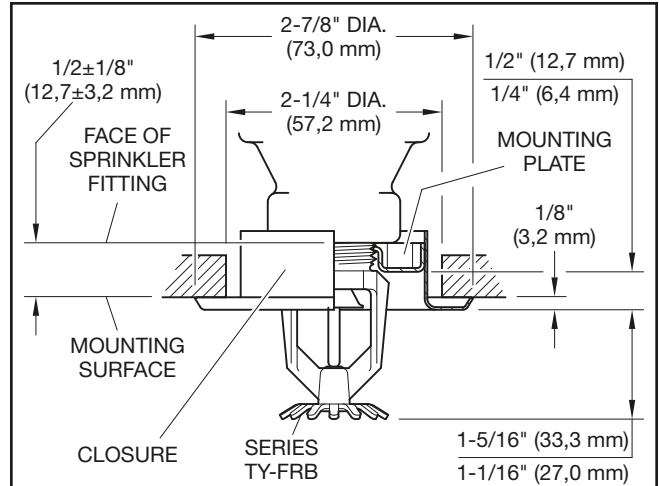
Automatic sprinkler systems are recommended to be inspected, tested, and maintained by a qualified Inspection Service in accordance with local requirements and/or national codes.

Care must be exercised to avoid damage to the sprinklers before, during, and after installation. Sprinklers damaged by dropping, striking, wrench twist/slippage, or the like, must be replaced. Also, replace any sprinkler that has a cracked bulb or that has lost liquid from its bulb. For more information, see Installation section.

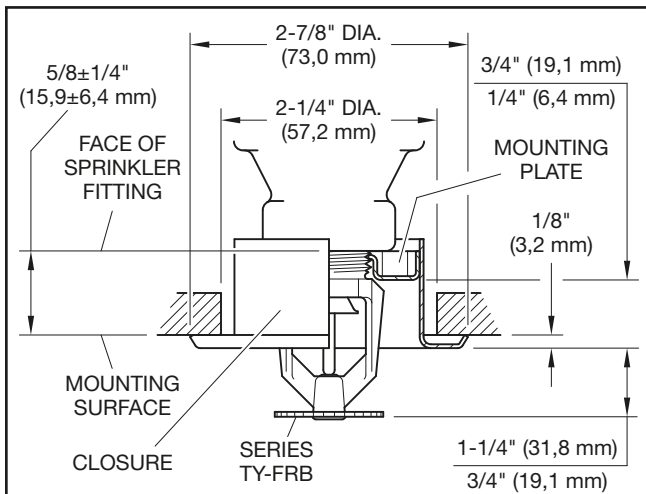
Initial and frequent visual inspections of random samples are recommended for corrosion-resistant sprinklers to verify the integrity of the corrosion-resistant material of construction. Thereafter, annual inspections per NFPA 25 should suffice. Inspections of corrosion-resistant sprinklers are recommended at close range, instead of from the floor level per NFPA. Inspection at close range can better determine the exact sprinkler condition and the long-term integrity of the corrosion-resistant material, which can be affected by the corrosive conditions present.



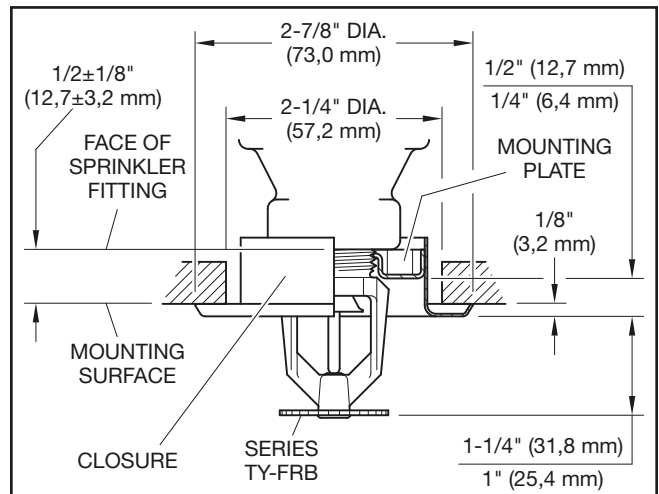
**FIGURE 6**  
**SERIES TY-FRB RECESSED PENDENT**  
**WITH TWO-PIECE 3/4 INCH TOTAL ADJUSTMENT**  
**STYLE 10 RECESSED ESCUTCHEON**  
**2.8 K-FACTOR, 1/2 IN. NPT**



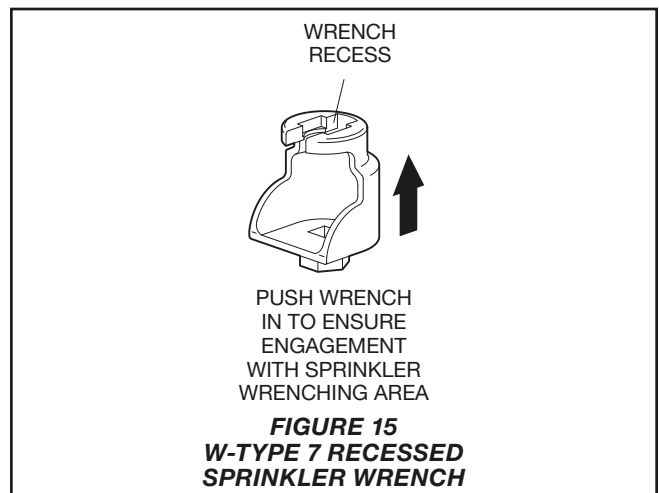
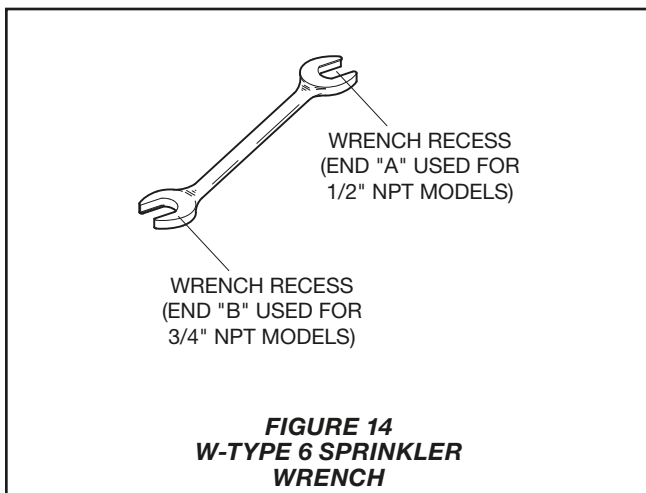
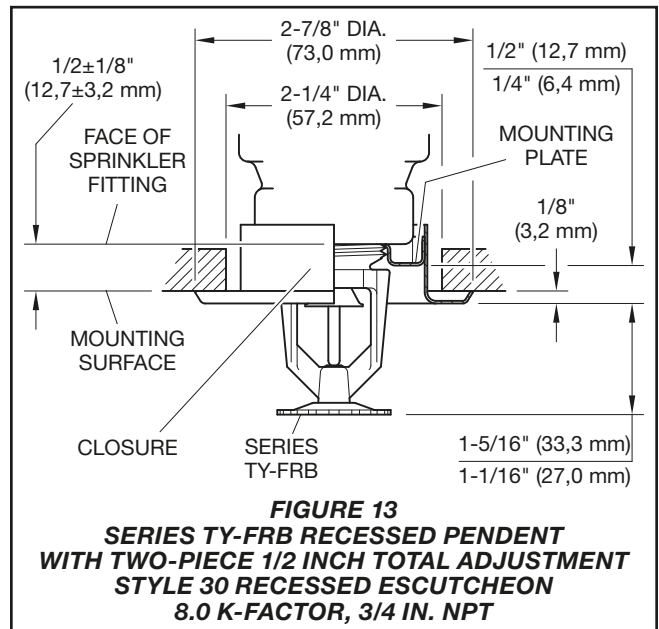
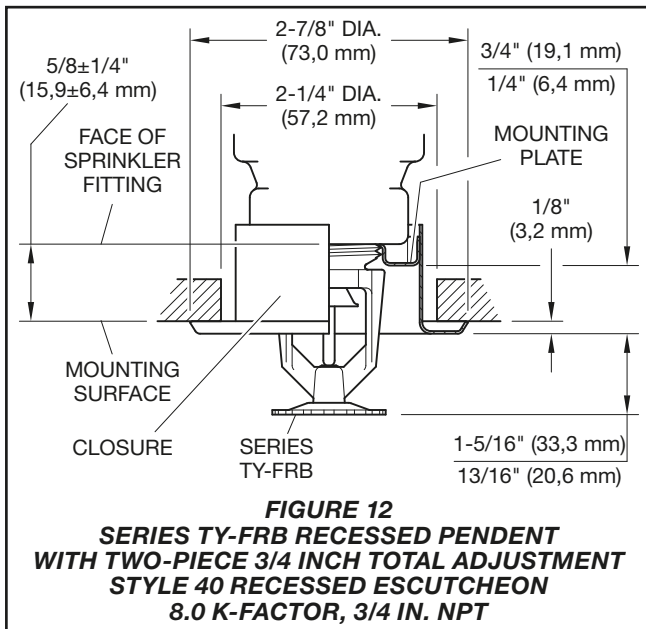
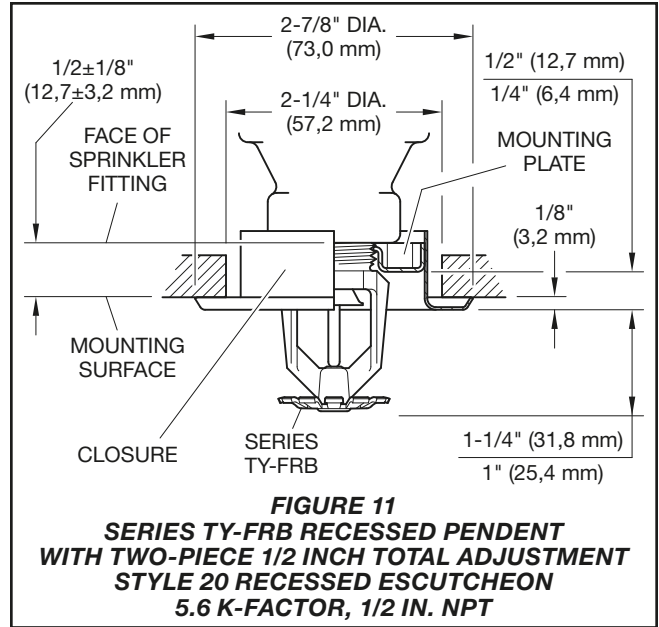
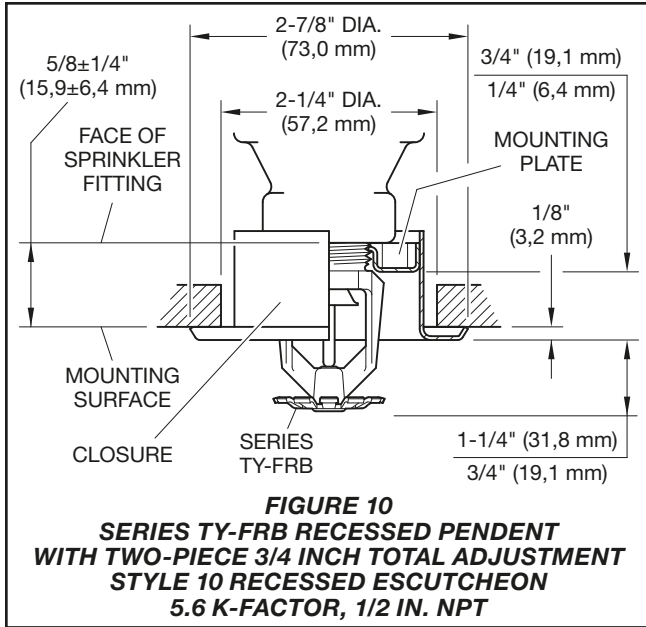
**FIGURE 7**  
**SERIES TY-FRB RECESSED PENDENT**  
**WITH TWO-PIECE 1/2 INCH TOTAL ADJUSTMENT**  
**STYLE 20 RECESSED ESCUTCHEON**  
**2.8 K-FACTOR, 1/2 IN. NPT**



**FIGURE 8**  
**SERIES TY-FRB RECESSED PENDENT**  
**WITH TWO-PIECE 3/4 INCH TOTAL ADJUSTMENT**  
**STYLE 10 RECESSED ESCUTCHEON**  
**4.2 K-FACTOR, 1/2 IN. NPT**



**FIGURE 9**  
**SERIES TY-FRB RECESSED PENDENT**  
**WITH TWO-PIECE 1/2 INCH TOTAL ADJUSTMENT**  
**STYLE 20 RECESSED ESCUTCHEON**  
**4.2 K-FACTOR, 1/2 IN. NPT**



K-Factor	Type	Temperature	Bulb Liquid Color	Sprinkler Finish <sup>5</sup>		
				Natural Brass	Chrome Plated	Polyester <sup>c</sup>
2.8 1/2 in. NPT	Pendent (TY1231)	135°F (57°C)	Orange	1, 2, 3, 4		
		155°F (68°C)	Red			
		175°F (79°C)	Yellow			
		200°F (93°C)	Green			
		286°F (141°C)	Blue			
	Upright (TY1131)	135°F (57°C)	Orange			
		155°F (68°C)	Red			
		175°F (79°C)	Yellow			
		200°F (93°C)	Green			
		286°F (141°C)	Blue			
	Recessed Pendent (TY1231) <sup>a</sup> Figure 6	135°F (57°C)	Orange	1, 2, 4		
		155°F (68°C)	Red			
		175°F (79°C)	Yellow			
		200°F (93°C)	Green			
	Recessed Pendent (TY1231) <sup>b</sup> Figure 7	135°F (57°C)	Orange			
		155°F (68°C)	Red			
175°F (79°C)		Yellow				
200°F (93°C)		Green				

**NOTES**

- a. Installed with Style 10 (1/2 in. NPT) or Style 40 (3/4 in. NPT) 3/4 in. Total Adjustment Recessed Escutcheon, as applicable.
- b. Installed with Style 20 (1/2 in. NPT) or Style 30 (3/4 in. NPT) 1/2 in. Total Adjustment Recessed Escutcheon, as applicable.
- c. Frame and Deflector only.
1. Listed by Underwriters Laboratories, Inc., (UL) as Quick Response Sprinklers.
2. Listed by Underwriters Laboratories, Inc., for use in Canada (C-UL) as Quick Response Sprinklers.
3. Approved by Factory Mutual Research Corporation (FM) as Quick Response Sprinklers.
4. Approved by the City of New York under MEA 354-01-E.
5. Where Polyester Coated Sprinklers are noted to be UL and C-UL Listed, the sprinklers are UL and C-UL Listed as corrosion-resistant sprinklers.

**TABLE A**  
**LABORATORY LISTINGS AND APPROVALS FOR**  
**2.8 K-FACTOR SPRINKLERS**

K-Factor	Type	Temperature	Bulb Liquid Color	Sprinkler Finish <sup>3</sup>		
				Natural Brass	Chrome Plated	Polyester <sup>c</sup>
4.2 1/2 in. NPT	Pendent (TY2231)	135°F (57°C)	Orange	1, 2		
		155°F (68°C)	Red			
		175°F (79°C)	Yellow			
		200°F (93°C)	Green			
		286°F (141°C)	Blue			
	Upright (TY2131)	135°F (57°C)	Orange			
		155°F (68°C)	Red			
		175°F (79°C)	Yellow			
		200°F (93°C)	Green			
		286°F (141°C)	Blue			
	Recessed Pendent (TY2231) <sup>a</sup> Figure 8	135°F (57°C)	Orange			
		155°F (68°C)	Red			
		175°F (79°C)	Yellow			
		200°F (93°C)	Green			
	Recessed Pendent (TY2231) <sup>b</sup> Figure 9	135°F (57°C)	Orange			
		155°F (68°C)	Red			
175°F (79°C)		Yellow				
200°F (93°C)		Green				

**NOTES**

- a. Installed with Style 10 (1/2 in. NPT) or Style 40 (3/4 in. NPT) 3/4 in. Total Adjustment Recessed Escutcheon, as applicable.
- b. Installed with Style 20 (1/2 in. NPT) or Style 30 (3/4 in. NPT) 1/2 in. Total Adjustment Recessed Escutcheon, as applicable.
- c. Frame and Deflector only.
- 1. Listed by Underwriters Laboratories, Inc., (UL) as Quick Response Sprinklers.
- 2. Listed by Underwriters Laboratories, Inc., for use in Canada (C-UL) as Quick Response Sprinklers.
- 3. Where Polyester Coated Sprinklers are noted to be UL and C-UL Listed, the sprinklers are UL and C-UL Listed, the sprinklers are UL and C-UL Listed as corrosion-resistant sprinklers.

**TABLE B**  
**LABORATORY LISTINGS AND APPROVALS FOR**  
**4.2 K-FACTOR SPRINKLERS**

K-Factor	Type	Temperature	Bulb Liquid Color	Sprinkler Finish <sup>9</sup>			
				Natural Brass	Chrome Plated	Polyester <sup>c</sup>	Lead Coated
5.6 1/2 in. NPT	Pendent (TY3231)	135°F (57°C)	Orange	1, 2, 3, 4, 5, 6, 7, 8			1, 2, 3, 5, 8
		155°F (68°C)	Red				
		175°F (79°C)	Yellow				
		200°F (93°C)	Green				
		286°F (141°C)	Blue				
	Upright (TY3131)	135°F (57°C)	Orange	1, 2, 3, 5, 6, 8			1, 2, 3, 5, 8
		155°F (68°C)	Red				
		175°F (79°C)	Yellow				
		200°F (93°C)	Green				
		286°F (141°C)	Blue				
	Recessed Pendent (TY3231) <sup>a</sup> Figure 10	135°F (57°C)	Orange	1, 2, 4, 5, 8			N/A <sup>d</sup>
		155°F (68°C)	Red				
		175°F (79°C)	Yellow				
		200°F (93°C)	Green				
		286°F (141°C)	Blue				
	Recessed Pendent (TY3231) <sup>b</sup> Figure 11	135°F (57°C)	Orange	1, 2, 3, 4, 5, 8			N/A
155°F (68°C)		Red					
175°F (79°C)		Yellow					
200°F (93°C)		Green					
286°F (141°C)		Blue					

**NOTES**

- a. Installed with Style 10 (1/2 in. NPT) or Style 40 (3/4 in. NPT) 3/4 in. Total Adjustment Recessed Escutcheon, as applicable.
- b. Installed with Style 20 (1/2 in. NPT) or Style 30 (3/4 in. NPT) 1/2 in. Total Adjustment Recessed Escutcheon, as applicable.
- c. Frame and Deflector only.
- d. Not available (N/A).
1. Listed by Underwriters Laboratories, Inc., (UL) as Quick Response Sprinklers.
2. Listed by Underwriters Laboratories, Inc., for use in Canada (C-UL) as Quick Response Sprinklers.
3. Approved by Factory Mutual Research Corporation (FM) as Quick Response Sprinklers.
4. Approved by the Loss Prevention Certification Board (LPCB Ref. No. 007k/04) as Quick Response Sprinklers. However, LPCB does not rate the thermal sensitivity of recessed sprinklers.
5. Approved by the City of New York under MEA 354-01-E.
6. VdS Approved (For details, contact Johnson Controls, Enschede, Netherlands, Tel. 31-53-428-4444/Fax 31-53-428-3377.)
7. Approved by the Loss Prevention Certification Board (LPCB Ref. No. 094a/06) as Quick Response Sprinklers.
8. EAC Approved.
9. Where Polyester Coated and Lead-Coated Sprinklers are noted to be UL and C-UL Listed, the sprinklers are UL and C-UL Listed as Corrosion-Resistant Sprinklers. Where Lead-Coated Sprinklers are noted to be FM Approved, the sprinklers are FM Approved as a Corrosion-Resistant Sprinklers.

**TABLE C**  
**LABORATORY LISTINGS AND APPROVALS FOR**  
**5.6 K-FACTOR SPRINKLERS**

K-Factor	Type	Temperature	Bulb Liquid Color	Sprinkler Finish <sup>9</sup>							
				Natural Brass	Chrome Plated	Polyester <sup>c</sup>	Lead Coated				
8.0 3/4 in. NPT	Pendent (TY4231)	135°F (57°C)	Orange	1, 2, 3, 4, 5, 6, 7, 8		Polyester <sup>c</sup>	1, 2, 5, 8				
		155°F (68°C)	Red								
		175°F (79°C)	Yellow								
		200°F (93°C)	Green								
		286°F (141°C)	Blue								
	Upright (TY4131)	135°F (57°C)	Orange								
		155°F (68°C)	Red								
		175°F (79°C)	Yellow								
		200°F (93°C)	Green								
		286°F (141°C)	Blue								
	Recessed Pendent (TY4231) <sup>a</sup> Figure 12	135°F (57°C)	Orange					1, 2, 5, 8		Polyester <sup>c</sup>	N/A <sup>d</sup>
		155°F (68°C)	Red								
		175°F (79°C)	Yellow								
		200°F (93°C)	Green								
		286°F (141°C)	Blue								
	Recessed Pendent (TY4231) <sup>b</sup> Figure 13	135°F (57°C)	Orange					1, 2, 3, 5, 8		Polyester <sup>c</sup>	N/A
155°F (68°C)		Red									
175°F (79°C)		Yellow									
200°F (93°C)		Green									
286°F (141°C)		Blue									
8.0 1/2 in. NPT	Pendent (TY4931)	135°F (57°C)	Orange	1, 2, 4, 5, 6, 8		Polyester <sup>c</sup>	1, 2, 5, 8				
		155°F (68°C)	Red								
		175°F (79°C)	Yellow								
		200°F (93°C)	Green								
		286°F (141°C)	Blue								
	Upright (TY4831)	135°F (57°C)	Orange								
		155°F (68°C)	Red								
		175°F (79°C)	Yellow								
		200°F (93°C)	Green								
		286°F (141°C)	Blue								

**NOTES**

- a. Installed with Style 10 (1/2 in. NPT) or Style 40 (3/4 in. NPT) 3/4 in. Total Adjustment Recessed Escutcheon, as applicable.
- b. Installed with Style 20 (1/2 in. NPT) or Style 30 (3/4 in. NPT) 1/2 in. Total Adjustment Recessed Escutcheon, as applicable.
- c. Frame and Deflector only.
- d. Not available (N/A).
1. Listed by Underwriters Laboratories, Inc., (UL) as Quick Response Sprinklers.
2. Listed by Underwriters Laboratories, Inc., for use in Canada (C-UL) as Quick Response Sprinklers.
3. Approved by Factory Mutual Research Corporation (FM) as Quick Response Sprinklers.
4. Approved by the Loss Prevention Certification Board (LPCB Ref. No. 007k/04) as Quick Response Sprinklers. However, LPCB does not rate the thermal sensitivity of recessed sprinklers.
5. Approved by the City of New York under MEA 354-01-E.
6. VdS Approved (For details, contact Johnson Controls, Enschede, Netherlands, Tel. 31-53-428-4444/Fax 31-53-428-3377.)
7. Approved by the Loss Prevention Certification Board (LPCB Ref. No. 094a/06) as Quick Response Sprinklers.
8. EAC Approved.
9. Where Polyester Coated and Lead-Coated Sprinklers are noted to be UL and C-UL Listed, the sprinklers are UL and C-UL Listed as Corrosion-Resistant Sprinklers. Where Lead-Coated Sprinklers are noted to be FM Approved, the sprinklers are FM Approved as a Corrosion-Resistant Sprinklers.

**TABLE D**  
**LABORATORY LISTINGS AND APPROVALS FOR**  
**5.6 AND 8.0 K-FACTOR SPRINKLERS**



K-Factor	Type	Sprinkler Finish			
		Natural Brass	Chrome Plated	Polyester	Lead Coated
2.8 1/2 in. NPT	Pendent (TY1231) and Upright (TY1131)	175 psi (12,1 bar)			N/A <sup>2</sup>
	Recessed Pendent (TY1231)				
4.2 1/2 in. NPT	Pendent (TY2231) and Upright (TY2131)	175 psi (12,1 bar)			N/A
	Recessed Pendent (TY2231)				
5.6 1/2 in. NPT	Pendent (TY3231) and Upright (TY3131)	250 psi (17,2 bar) or 175 psi (12,1 bar) <sup>1</sup>			
	Recessed Pendent (TY3231)				
8.0 3/4 in. NPT	Pendent (TY4231) and Upright (TY4131)	175 psi (12,1 bar)			175 psi (12,1 bar)
	Recessed Pendent (TY4231)				N/A
8.0 1/2 in. NPT	Pendent (TY4931) and Upright (TY4831)	175 psi (12,1 bar)			175 psi (12,1 bar)
<b>NOTES</b> 1. The maximum working pressure of 250 psi (17,2 bar) only applies to the Listing by Underwriters Laboratories Inc. (UL); the Listing by Underwriters Laboratories, Inc. for use in Canada (C-UL); and, the Approval by the City of New York. 2. Not available (N/A).					
<b>TABLE E</b> <b>MAXIMUM WORKING PRESSURE</b>					

P/N 57 – XXX – X – XXX

		SIN	SPRINKLER FINISH		TEMPERATURE RATINGS	
330	2.8K UPRIGHT (1/2 in. NPT)	TY1131	1	NATURAL BRASS	135	135°F (57°C)
331	2.8K PENDENT (1/2 in. NPT)	TY1231	3	PURE WHITE POLYESTER (RAL9010) <sup>1</sup>	155	155°F (68°C)
340	4.2K UPRIGHT (1/2 in. NPT)	TY2131	4	SIGNAL WHITE POLYESTER (RAL9003)	175	175°F (79°C)
341	4.2K PENDENT (1/2 in. NPT)	TY2231	5	JET BLACK POLYESTER (RAL9005) <sup>2</sup>	200	200°F (93°C)
370	5.6K UPRIGHT (1/2 in. NPT)	TY3131	7	LEAD COATED	286	286°F (141°C)
371	5.6K PENDENT (1/2 in. NPT)	TY3231	9	CHROME PLATED		
390	8.0K UPRIGHT (3/4 in. NPT)	TY4131				
391	8.0K PENDENT (3/4 in. NPT)	TY4231				
360	8.0K UPRIGHT (1/2 in. NPT)	TY4831				
361	8.0K PENDENT (1/2 in. NPT)	TY4931				

**NOTES**  
1. Eastern Hemisphere sales only.  
2. Available in only 2.8K, 4.2K, and 8.0K, 155°F (68°C) and 200°F (93°C); requires longer lead time to manufacture.

**TABLE F**  
**SERIES TY-FRB PENDENT AND UPRIGHT SPRINKLERS**  
**PART NUMBER SELECTION**

## Limited Warranty

For warranty terms and conditions, visit [www.tyco-fire.com](http://www.tyco-fire.com).

## Ordering Procedure

Contact your local distributor for availability. When placing an order, indicate the full product name and Part Number (P/N).

### Sprinkler Assemblies with NPT Thread Connections

Specify: Series TY-FRB (Specify SIN), (specify K-factor), (specify Pendent or Upright) Sprinkler (specify) temperature rating, (specify) finish or coating, P/N (specify from Table F)

### Recessed Escutcheon

Specify: Style (10, 20, 30, or 40) Recessed Escutcheon with (specify\*) finish, P/N (specify\*)

\* Refer to Technical Data Sheet TFP770

### Sprinkler Wrench

Specify: W-Type 6 Sprinkler Wrench, P/N 56-000-6-387

Specify: W-Type 7 Sprinkler Wrench, P/N 56-850-4-001

# FlexHead commercial fire sprinkler connections



## Submittal Package

**FLEXHEAD**<sup>®</sup>

INDUSTRIES 

*The best idea in sprinkler systems since water*



N.Y.C. MEA #261-99-E  
CA: OPA-0672



**FLEXHEAD<sup>®</sup>**  
INDUSTRIES 

*The best idea in sprinkler systems since water*

# FlexHead commercial fire sprinkler connections

## Index

Installation Instructions	1
NFPA 13 Code Language and Seismic Qualification	3
Friction Loss Data and Specifications	5
Product Specification Sheets	7
FM Global: Testing & Approvals	9
Underwriters Laboratories: Testing & Listings	11
Loss Prevention Certification Board: Testing & Certifications	13
CA Office of Statewide Health Planning and Development	15
Other Approvals/Information	17
MEA Approval: NYC Department of Buildings	19
Limited Warranty	20

## WARNING!

These installation instructions are for qualified and/or licensed technicians in the Fire Protection field **ONLY**. Consult NFPA, FM, UL, state and local code guidelines prior to installation.

Failure to follow these specific instructions may cause personal injury. Installation technicians must read the entire manual prior to attempting installation of product. During maintenance or inspection of FlexHead product, facility fire protection system **MUST BE INACTIVE. DO NOT ATTEMPT RELOCATION OR MAINTENANCE WHEN FIRE PROTECTION SYSTEM IS "LIVE."**

## Installation Instructions (dated 8/20/08)

### Tools Required

Standard pipe wrench  
Safety glasses  
Adjustable wrench  
Screwdriver

### Materials Required

Sprinkler pipe thread sealant  
Teflon® tape

### 1. Mounting Bracket Assembly M#: MP-24-BKT-2

Remove one (1) 3/8" bolt and one (1) 1/4" bolt from hardware bag in box. Remove (1) universal hub and one (1) mounting bracket from box. Thread the 3/8" bolt through side of universal hub. Select one (1) of the four (4) sprinkler port locations on mounting bracket.

- A. Insert tab of universal hub into slot on mounting bracket as shown. (Photo 1a)
- B. Flip bracket over and insert and tighten 1/4" attachment bolt thru pre-punched hole in bracket until tight as shown. (Photo 1b)



- B. Thread the 3/8" bolt through side of universal hub.



### 2. Attach Mounting Bracket to T-bar Suspended Ceiling Grid

**Note:** These products are designed for use with Intermediate or Heavy Duty ceiling grids manufactured to ASTM C 635 (*Standard Specification for the Manufacture, Performance, and Testing of Metal Suspension Systems for Acoustical Tile and Lay-in Panel Ceilings*) and ASTM C 636 (*Standard Practice for Installation of Metal Ceiling Suspension Systems for Acoustical Tile and Lay-in Panels*) Designation.

- A. From above the ceiling, position FlexHead Mounting Bracket ends on to T-bar grid so that the center hole in support bracket aligns directly above the sprinkler hole prepared in ceiling tile. Be sure the center section of the bracket end is on the outside of grid and base section is on the inside. Position the ends of the support bracket on the T-bar grid and push each of the two (2) ends of the bracket down to snap in place as shown. (Photo 2)

### 3. Anchor Bracket to T-bar Grid

- A. Anchor bracket to t-bar grid with self tapping screw through bottom hole in bracket end into



grid. Be sure to install self tapping screw in lower hole of bracket end with attachment clip as shown. Repeat process on opposite end of bracket. Both ends of bracket should be anchored as shown.

(Photo 3)

#### 4. Connect FlexHead to Sprinkler Branch-line

Apply teflon tape and pipe sealant to one inch (1") threaded end of FlexHead Sprinkler Drop per NFPA guidelines. Attach one inch (1") threaded end of FlexHead Sprinkler Drop to branch-line per NFPA, State and local code guidelines.

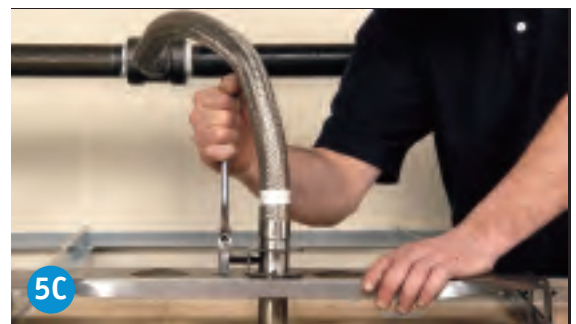
The flexible hose with fitting is only intended to be installed with bends.

Do not use welded or braided hose section of FlexHead Sprinkler Drop for a wrenching surface. **Attach FlexHead Sprinkler Drop using rigid pipe end of units as wrenching surface as shown.** (Photo 4)



#### 5. Secure FlexHead Sprinkler Drop to Mounting Bracket and Install Sprinkler Head

- A. Bend the Flexhead to hold its desired position. **Do not overbend the flexible hose. FlexHead has a 3" (75mm) minimum bend radius per UL guidelines.** Insert reducing coupling end of FlexHead Sprinkler Drop through center hole in previously installed support bracket and hole in ceiling tile. Make sure the hose is bent sufficiently so that the reducing coupling sits perfectly vertical in center hole of support bracket. Do not torque or twist FlexHead during installation process. (Photo 5a)
- B. Attach sprinkler head, properly prepared with teflon tape and sealant to FlexHead Sprinkler Drop according to NFPA and sprinkler head manufacturer's guidelines. (Photo 5b)



- C. Adjust FlexHead Sprinkler height to accommodate type of sprinkler head. When sprinkler head is in desired location, tighten the fastening bolt on center hub of support bracket by turning clockwise hand tight plus 1 turn (100 inch lbs) with wrench as shown. After tightening the bolt, tighten the nut hand tight plus 1 turn (100 inch lbs) with wrench. (Photo 5c)

#### 6. Installation of the FlexHead Ceiling Sprinkler System Is Complete

- Test installation of sprinkler system for any leaks per NFPA Guidelines.
- Install sprinkler escutcheon from below ceiling per manufacturers guidelines.

## NFPA 13 Code Language and Seismic Qualification

### NFPA 13 Standard for Installation of Sprinkler Systems 2007 Edition

---

- 9.2.1.3.3\*** Flexible Sprinkler Hose Fittings.
- A. 9.2.1.3.3** Examples of areas of use include clean rooms, suspended ceilings, and exhaust ducts.
- 9.2.1.3.3.1** Listed flexible sprinkler hose fittings and its anchoring components, intended for use in installations connecting the sprinkler piping to sprinklers, shall be installed in accordance with the requirements of the listing including any installation instructions.
- 9.2.1.3.3.2** When installed and supported by suspended ceilings, the ceiling shall meet ASTM C-635 and shall be installed in accordance with ASTM C-636.
- 9.2.1.3.3.3\*** When flexible sprinkler hose fittings exceed 6 ft in length and are supported by a suspended ceiling a hanger(s) attached to the structure shall be required to ensure that the maximum unsupported length does not exceed 6 ft.
- A. 9.2.1.3.3.3** The committee evaluation of flexible sprinkler hose fittings supported by suspended ceilings was based upon a comparison of the weight of a 6 ft, 1 in diameter sch 40 water-filled flexible hose fitting weighing approximately 9 lbs. The information provided to the committee showed that the maximum load shed to the suspended ceiling by the flexible hose fitting was approximately 6 lbs and that a suspended ceiling meeting ASTM C-635, *Standard Specification for the Manufacture, Performance, and Testing of Metal Suspension of Acoustical Tile and Lay-In Panel Ceilings*, and installed in accordance with ASTM C-636, *Standard Practice for Installation of Metal Ceiling Suspension Systems for Acoustical Tile and Lay-In Panels*, can substantially support the load. In addition, the supporting material showed that the flexible hose connection can be attached to the suspended ceilings because it allows the necessary deflections under seismic conditions.



# FlexHead® Flexible Sprinkler Connections Satisfy New Seismic Code Requirements

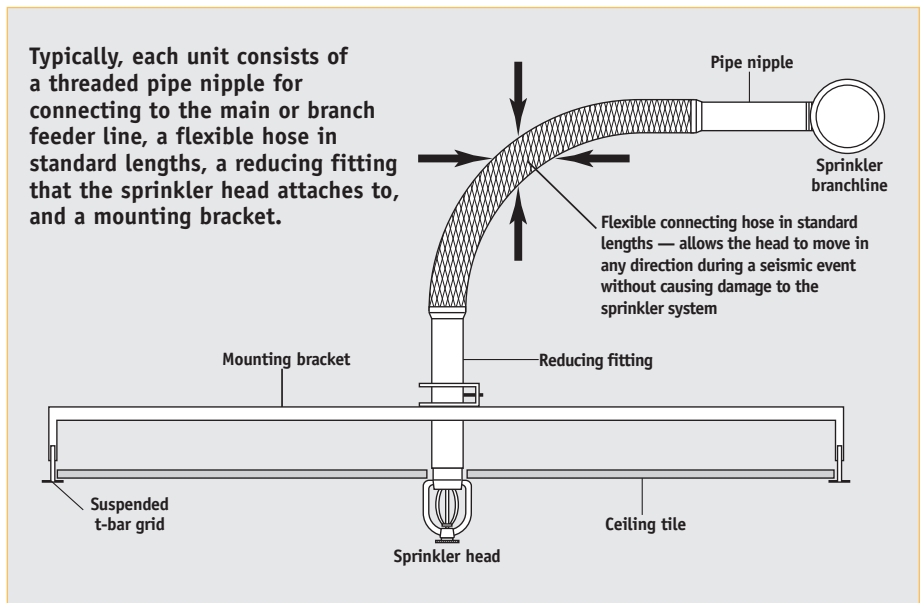
## Background of New Code Requirements:

More than 90% of the states in the U.S. are adopting the International Building Code (IBC) that address, among other things, the installation of fire sprinkler systems in seismic zones. The code is intended to neutralize the probability of fire sprinkler systems being damaged and made inoperable by seismic activity, including ceiling movement than can shear sprinkler heads and/or disrupt the integrity of arm-over connections from the branch lines.

**The IBC Code and Sprinkler Design in Suspended Ceilings:** The latest version of the IBC

defers to ASCE 7 for the sprinkler/ceiling design in Seismic Design Categories (SDC) C and D, E & F. In Seismic Design Category C, suspended ceilings are to be designed and installed in accordance with Ceilings & Interior Systems Construction Association (CISCA) recommendations for Zones 0-2; and sprinkler heads and other penetrations shall have a minimum of 1/4-inch clearance on all sides. In Seismic Design Categories D, E & F, suspended ceilings are to be designed and installed in accordance with CISCA recommendations for seismic Zones 3 and 4 with some additional requirements. Except where rigid braces are used to limit lateral deflections, sprinkler heads and other penetrations shall have a 2-inch oversized ring, sleeve, or adapter through the ceiling to allow for free movement of at least 1 inch of ceiling movement in all horizontal directions.

**Flexible Sprinkler Connections Exceed IBC Code Requirements:** Flexible sprinkler connections provide characteristics that exceed the most stringent seismic code requirements. The flexibility of the hose allows



FlexHead Industries recently satisfactorily completed full-scale seismic qualification testing at the Structural Engineering Earthquake Simulation Laboratory located at the State University of New York at Buffalo. Tests were conducted using the International Code Council (ICC) acceptance criteria "ICC-ES AC-156 Seismic Qualification Testing of Nonstructural Components". This is the first time a sprinkler component has been seismically certified using test criteria accepted by the ICC.

the head to move with the ceiling in any direction during a seismic event without causing damage to the sprinkler system. **FlexHead Industries recently satisfactorily completed full-scale seismic qualification testing at the Structural Engineering Earthquake Simulation Laboratory located at the State University of New York at Buffalo using the International Code Council (ICC) testing standard "ICC AC-156 Seismic Qualification Testing of Nonstructural Components". This is the first time a sprinkler component has been seismically certified using test criteria accepted by the IBC.** FlexHeads were installed in suspended ceilings meeting the code requirements for Seismic Design Category C and Seismic Design Categories D, E & F and were subjected to the highest accelerations determined for each Seismic Design Category. No damage to the fire sprinkler system or suspended ceiling system was observed, and the sprinkler heads remained in their intended location during all of the test performed.

## Friction Loss Data and Specifications

F R I C T I O N L O S S	FlexHead Model #	Outlet Size in (cm)	Hose Assembly Length ft (m)	Maximum Number of 90-Degree Bends (3 in. Bending Radius)	FM/UL Maximum Equivalent Length of Schedule 40, Nominal 1 in. Diameter Pipe, ft FM/UL	Maximum Ambient Temperature Rating F(C)	Maximum Rated Pressure  H-Series psi (kPa)/psi (kPa)
		2024, 2024H	1/2(1.27)	2(0.6)	3	3.5/11	300°(148°)
	2036, 2036H	1/2(1.27)	3(0.9)	3	4.8/16	300°(148°)	175(1205)/300(2068)
	2048, 2048H	1/2(1.27)	4(1.2)	4	6.8/24	300°(148°)	175(1205)/300(2068)
	2060, 2060H	1/2(1.27)	5(1.5)	4	8.5/29	300°(148°)	175(1205)/300(2068)
	2072, 2072H	1/2(1.27)	6(1.8)	4	8.9/35	300°(148°)	175(1205)/300(2068)
	2024, 2024H	3/4(1.90)	2(0.6)	3	7.8/12	300°(148°)	175(1205)/300(2068)
	2036, 2036H	3/4(1.90)	3(0.9)	3	8.1/18	300°(148°)	175(1205)/300(2068)
	2048, 2048H	3/4(1.90)	4(1.2)	4	17.9/23	300°(148°)	175(1205)/300(2068)
	2060, 2060H	3/4(1.90)	5(1.5)	4	19.9/29	300°(148°)	175(1205)/300(2068)
	2072, 2072H	3/4(1.90)	6(1.8)	4	24.3/32	300°(148°)	175(1205)/300(2068)
	2024E, 2024HE	1/2(1.27)	2(0.6)	3	5.5/19	300°(148°)	175(1205)/300(2068)
	2036E, 2036HE	1/2(1.27)	3(0.9)	3	6.8/23	300°(148°)	175(1205)/300(2068)
	2048E, 2048HE	1/2(1.27)	4(1.2)	4	8.8/27	300°(148°)	175(1205)/300(2068)
	2060E, 2060HE	1/2(1.27)	5(1.5)	4	10.5/32	300°(148°)	175(1205)/300(2068)
	2072E, 2072HE	1/2(1.27)	6(1.8)	4	10.9/35	300°(148°)	175(1205)/300(2068)
	2024E, 2024HE	3/4(1.90)	2(0.6)	3	9.8/18	300°(148°)	175(1205)/300(2068)
	2036E, 2036HE	3/4(1.90)	3(0.9)	3	10.1/23	300°(148°)	175(1205)/300(2068)
	2048E, 2048HE	3/4(1.90)	4(1.2)	4	19.9/23	300°(148°)	175(1205)/300(2068)
	2060E, 2060HE	3/4(1.90)	5(1.5)	4	21.9/29	300°(148°)	175(1205)/300(2068)
	2072E, 2072HE	3/4(1.90)	6(1.8)	4	26.3/32	300°(148°)	175(1205)/300(2068)

Model Numbers: The "H" designates high pressure unit rated to 300 psig and the "E" designates elbow style unit.

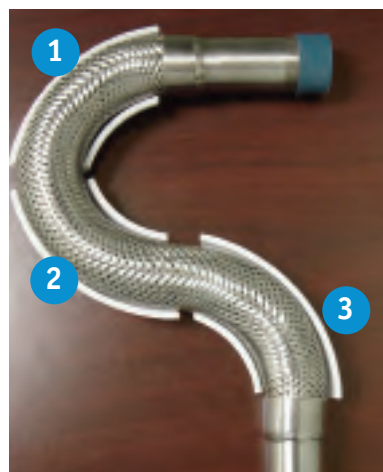
FlexHead products are intended for use in hydraulically designed wet, pre-action, deluge or dry pipe sprinkler connections per NFPA 13, 13R, and 13D guidelines. The hydraulic loss of the FlexHead connector needs to be included in the hydraulic design calculations the same as a valve or fitting. *Each FlexHead sprinkler drop has a 3" minimum bend radius per UL guidelines, and a 7" minimum bend radius per FM guidelines.*

\* Equivalent lengths are shown with maximum number of 90 degree bends at the minimum bend-radius. Different values were obtained by FM and UL due to the differences in minimum bend radius, testing protocol and calculation methods. Please see individual testing standards for more information relative to friction loss (Equivalent Length of Pipe).

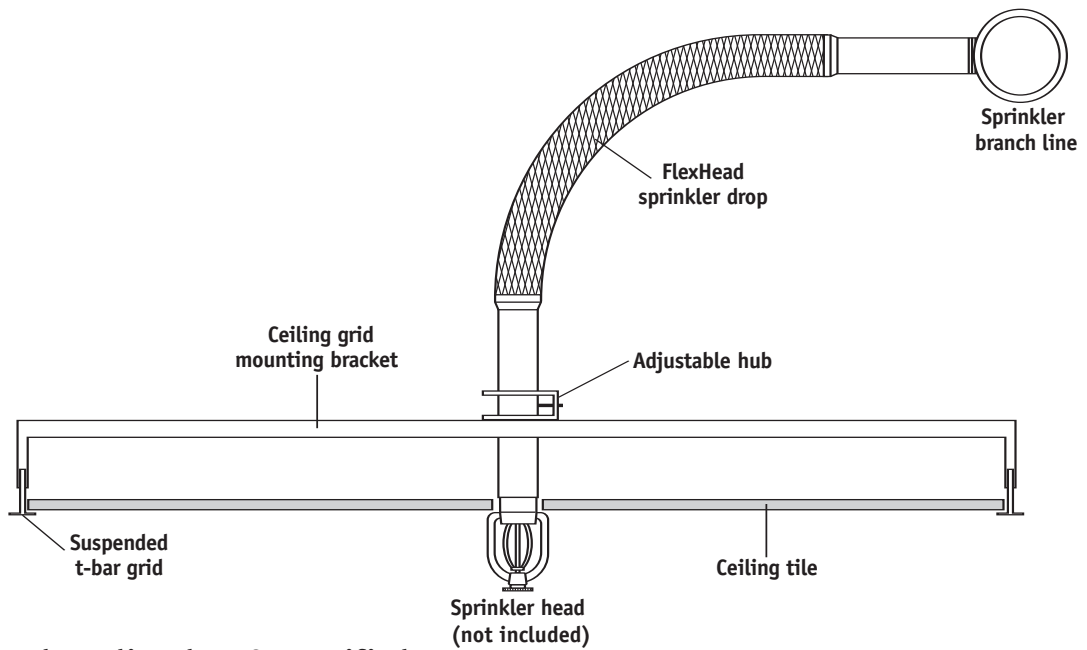
**FlexHead 3" Bend Radius per UL Guidelines (2 Bends Shown)**



**FlexHead Shown with 3 Bends**

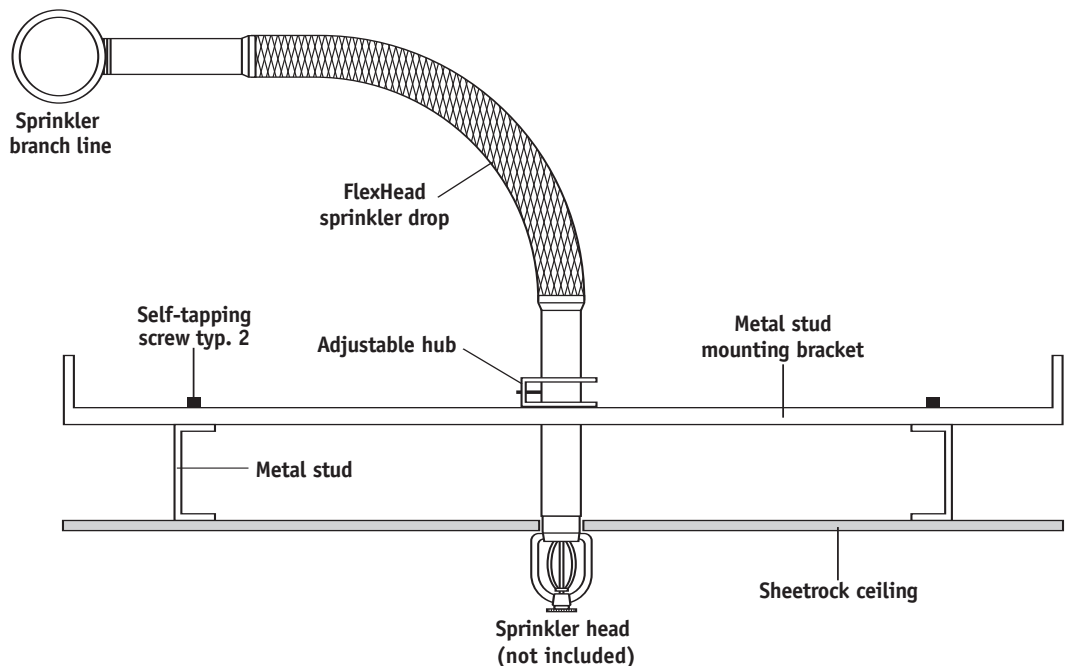


# FlexHead Suspended Ceiling Detail

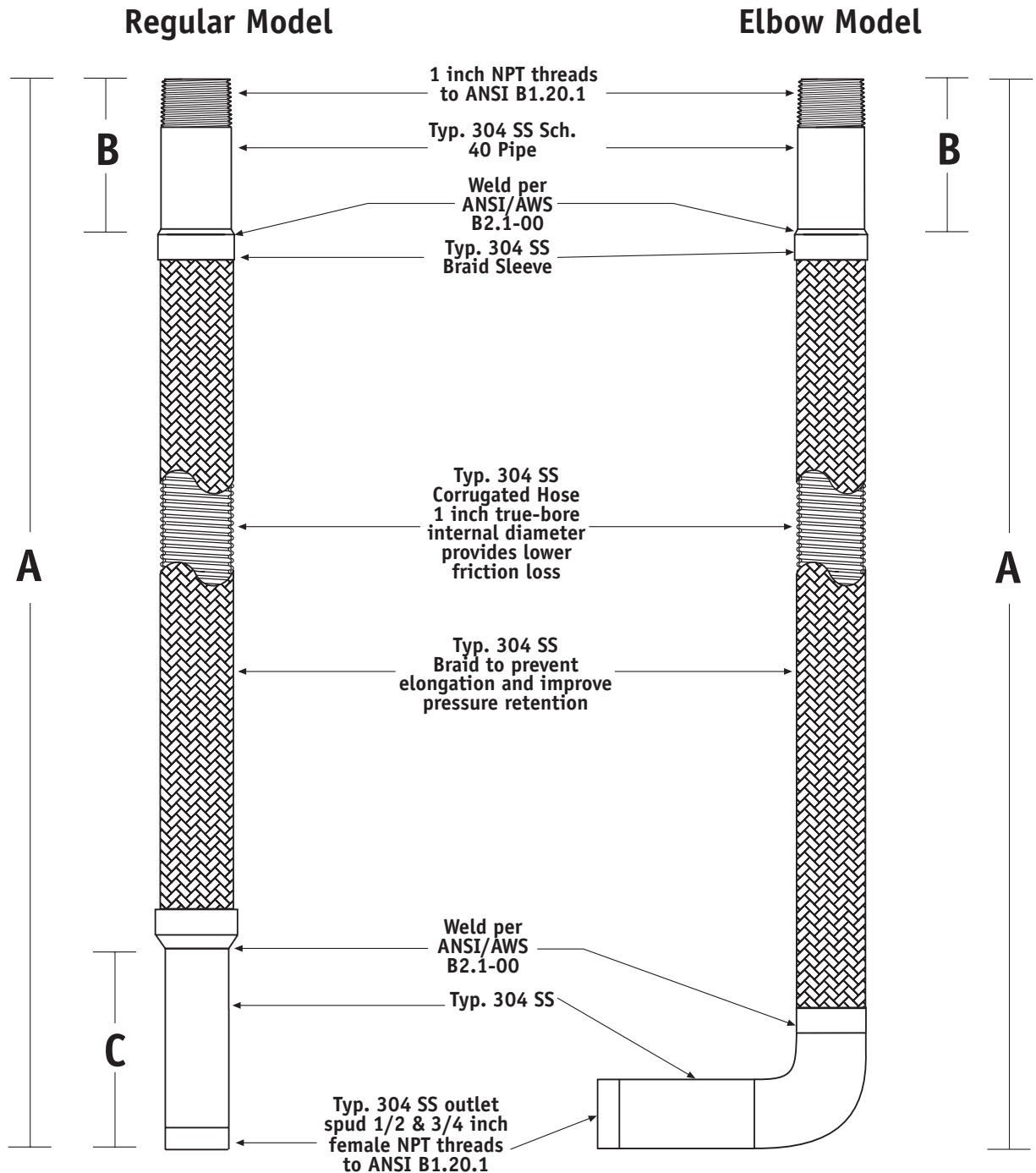


Each FM approved, UL listed, LPCB certified unit is ready to install, pressure- and leak-tested, and comes complete with a flexible stainless steel hose and mounting bracket with adjustable hub.

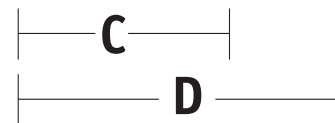
# FlexHead Sheetrock Ceiling Detail



## Hose Specification Sheet

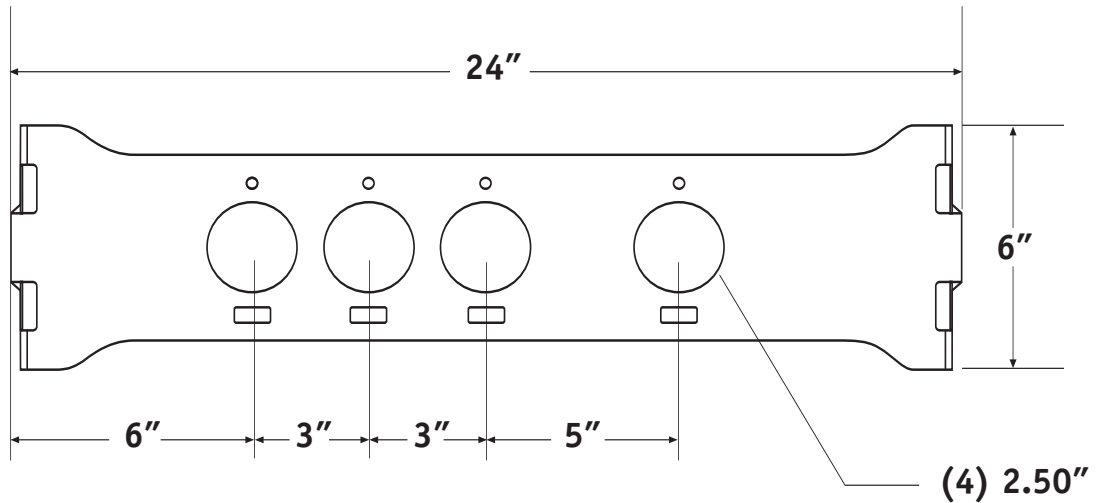


Model #	A (in.)	B (in.)	C (in.)	D (in.)
2024	24	3	4.5	6
2036	36	3	4.5	6
2048	48	3	4.5	6
2060	60	3	4.5	6
2072	72	3	4.5	6

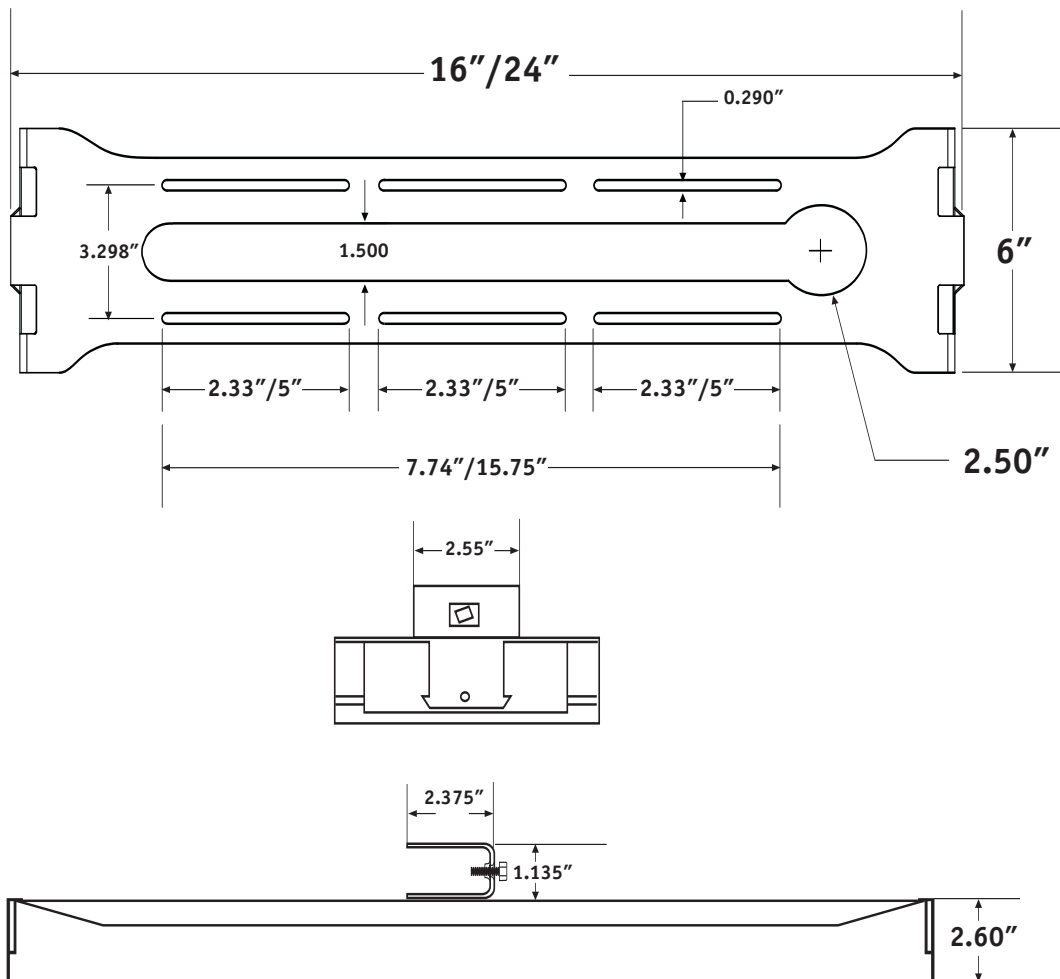


# Bracket Specification Sheet

## Multiport Design (For use with T-bar grid and metal stud applications)



## Adjustable Design (For use with T-bar grid, metal stud, and Chicago grid applications): standard sizes are 16" and 24" long



## Testing and Approvals

### FM Global Testing — Approval Standard FM1637\*

FlexHead® series 2000 stainless steel sprinkler connections

#### Hydrostatic Strength Test

A sample FlexHead was subjected to a hydrostatic pressure of four (4) times the rated working pressure of 175 psi (1205 kpa) to 700 psi (4825 kpa) for a period of five minutes. The assembly showed no signs of rupture, cracking, permanent distortion, or deterioration of performance characteristics. *The FlexHead successfully passed this test.*

#### Vibration Test

A sample FlexHead was secured to a vibration table. The FlexHead hose was bent in a 90° angle and pressurized to 90 psi (620 kpa) and the mounting bracket and hose were then subjected to a total of 25 hours of severe vibration conditions. After the successful completion of the vibration tests the sample was subjected to the hydrostatic pressure test at 700 psi and showed no signs of deterioration. *The FlexHead successfully passed this test.*

#### Friction Loss (Equivalent length of pipe)

To determine the effect of the FlexHead to the discharge coefficient of the sprinkler, the average friction loss through the FlexHead shall be equated to the theoretical length of nominal 1" diameter schedule 40 sprinkler pipe which would produce the same amount of friction loss. *Please see friction loss table.*

#### Vacuum Test

A sample FlexHead was subjected to a vacuum of 25 inHG for a period of five minutes. After the successful completion of the Vacuum Test the sample was subjected to the hydrostatic pressure test at 700 psi and showed no signs of deterioration. *The FlexHead successfully passed this test.*

#### Pressure Cycling Test

A sample FlexHead was filled with water and bent at a 90° angle and subjected to 20,000 cycles of pressure varying from 0 psi (0 kpa) to 175 psi (1205 kpa) at a rate of approximately 6 cycles per minute. After the successful completion of the pressure cycling tests the sample was subjected to the hydrostatic pressure test at 700 psi and showed no signs of deterioration. *The FlexHead successfully passed this test.*

#### Fatigue Test

A sample FlexHead was subjected to 50,000 cycles of repeated flexing at a rate of 5 to 30 cycles per minute per section 8.3 of ISO standard 10380. After the successful completion of the fatigue test the sample was subjected to the hydrostatic pressure test at 700 psi and showed no signs of deterioration. *The FlexHead successfully passed this test.*

#### Head Deployment

A sample FlexHead installed in a suspended ceiling was fitted with a sprinkler head and pressurized to 26–175 psi. The sprinkler head was then activated by a heat source at various pressures, and the sprinkler head deployed. The assembly showed no signs of distortion or deterioration of performance on the assembly or sprinkler head. *The FlexHead successfully passed this test.*

\* Condensed Summary — Please see approval standard for full testing and approval criteria.



APPROVED

## FLEXIBLE SPRINKLER HOSE WITH FITTINGS FOR COMMERCIAL SUSPENDED CEILINGS

Flexible sprinkler hose with threaded end fittings are for use in commercial suspended ceilings. The flexible hoses are to be installed according to the manufacturer’s directives. Unless indicated, the hoses have a rated working pressure of 175 (1205 kPa).

**Flexhead Industries, Inc. 56 Lowland St, Holliston MA 01746**

Model	NPT in.	Hose Assembly length ft (m)
2024/2024 75	1/2 / 3/4	2 (0.6)
2036/2036 75	1/2 / 3/4	3 (0.9)
2048/2048 75	1/2 / 3/4	4 (1.2)
2060/2060 75	1/2 / 3/4	5 (1.5)
2072/2072 75	1/2 / 3/4	6 (1.8)

This is a standard flexible hose with a pressure rating of 175 psi (1205 kPa). Approval on these models of flexible metal sprinkler hose is limited for use in commercial suspended ceilings, with a ceiling bracket system manufactured by FlexHead Industries Inc. The brackets are identified below.

Model	NPT in.	Hose Assembly length ft (m)
2024E	1/2	2 (0.6)
2036E	1/2	3 (0.9)
2048E	1/2	4 (1.2)
2060E	1/2	5 (1.5)
2072E	1/2	6 (1.8)

This is a standard flexible hose with a pressure rating of 175 psi (1205 kPa). Approval on these models of flexible metal sprinkler hose incorporates a stainless steel elbow welded on the outlet end of hose and are limited for use in commercial suspended ceilings, with a ceiling bracket system manufactured by FlexHead Industries Inc. The brackets are identified below.

Model	NPT in.	Hose Assembly length ft (m)
2024H	1/2	2 (0.6)
2036H	1/2	3 (0.9)
2048H	1/2	4 (1.2)
2060H	1/2	5 (1.5)
2072H	1/2	6 (1.8)

The “H” designation indicates a pressure rating of 300 psi (2070 kPa). Approval on these models of flexible metal sprinkler hose is limited for use in commercial suspended ceilings, with a ceiling bracket system manufactured by FlexHead Industries Inc. The brackets are identified below.

Model	NPT in.	Hose Assembly length ft (m)
2024I	1/2	2 (0.5)
2036I	1/2	3 (0.9)
2048I	1/2	4 (1.2)
2060I	1/2	5 (1.5)
2072I	1/2	6 (1.8)

The “I” designation indicates and “Institutional” flexible hose with a pressure rating of 175 psi (1205 kPa). Approval of these models of flexible metal sprinkler hose is limited for use with pendant and horizontal sidewall applications with a UH-1 ceiling/wall bracket manufactured by FlexHead Industries.

The different FlexHead Industries, Inc. Brackets are identified as follows:

### Part Number

MP-24-BKT-2

SP-06-TZ-BKT

AD-16-BKT-2

AD-24-BKT-2

TZ = Tech Zone

AD = Adjustable

BKT = Bracket

24 = Length in inches of bracket

06 = Length in inches of bracket

16 = Length in inches of bracket

## Testing and Listings

### Underwriters Laboratory Testing — Listing Standard UL2443\*

FlexHead® series 2000 stainless steel sprinkler connections

#### Hydrostatic Pressure Test

The sample length is to be measured and then the hydrostatic pressure increased to 1.5 times the rated working pressure and held for 1 minute. The sample length is then to be measured again and the length shall not change by more than 0.1 inch/foot of hose length.

#### Mechanical Strength Test

A flexible sprinkler hose with fittings installed in its intended position using the anchoring components referenced in the installation instructions shall withstand a torque of 60 pound-feet (81 Nm) applied to the outlet without movement of the fitting outlet, deformation, or fracture.

#### High Temperature Exposure Test

Two samples are to be prepared and subjected to a hydrostatic pressure of twice the rated working pressure. The samples are then to be allowed to dry and then exposed to an ambient temperature in accordance with Table 10.1 for 90 days. Following this exposure, the samples are to be individually subjected to a hydrostatic pressure of twice the rated working pressure for 1 minute.

#### Vibration Test

Samples are to be vibrated for a period of 30 hours at frequencies ranging from 18 to 37 Hz. During and after being subjected to the required vibration, the samples are to be examined for signs of leakage, rupture, or movement of the outlet fitting affecting the performance of the flexible hose assembly.

#### Equivalent Length Determination

A sample of each length shall be tested in straight lengths and with the maximum number of minimum radii bends referenced in the installation instructions. The calculated pressure loss from the piezometers, corrected for the inlet and outlet velocities, are to be subtracted from the test sample results to obtain a pressure drop for the fitting. Using the Hazen-Williams coefficient of friction of 120, the equivalent length, in feet (m) of pipe, is to be calculated.

#### Salt Spray Corrosion Test

Ferrous flexible sprinkler hose with fittings and ferrous anchoring components not protected with a coating shall withstand an exposure to a salt spray atmosphere for 10 days without exhibiting any incipient corrosion.

#### Stress-Corrosion Cracking of Stainless Steel Parts Test

Austenitic stainless steel parts shall show no evidence of cracking, delamination, or degradation after being subjected to boiling magnesium chloride solution. The exposure is to last for 150 hours. The test samples are to be examined using a microscope having a magnification of 25X for any cracking, delamination, or other degradation as a result of the test exposure.

#### Low Temperature Test for Dry Pipe Systems

Each sample is to be gradually pressurized with air to a pressure of 40 psig (276 kPa) and then sealed. The pressurized assembly is then to be placed horizontally in air maintained at a temperature of minus 40°F (minus 40°C) for a period of 24 hours. Following the 24 hour low temperature exposure, the assembly is to be placed in room ambient temperature of 73 ±5°F (23 ±3°C) for an additional 24 hour period. There shall be no decrease in the pressure in the assembly from the pressure measured before the low temperature exposure.

#### Pressure Cycling Test

The samples are to be connected to a pressure cycling apparatus, filled with water and vented of all air. The internal pressure is to be cycled 3,000 times from 0 psig (0 kPa) to twice the rated working pressure to 0 psig (0 kPa) at an approximate rate of 10 cycles per minute. During the pressure cycling, observations are to be made for evidence of leakage or physical damage.

#### Vacuum Test

Flexible sprinkler hose with fittings shall withstand a vacuum of minus 8.84 psi (minus 61 kPa) without collapse, leakage, or other deterioration of the flexible sprinkler hose and fitting performance characteristics.

#### High Pressure Flow Test

Flexible sprinkler hose with fittings and its anchoring components shall maintain the attached sprinkler in the intended operating position while the sprinkler discharges water at 90 percent of the rated pressure of the flexible sprinkler hose.

#### Fatigue Test (Limited Flexibility)

Flexible hose with fittings shall withstand without leakage or damage repeated flexing in a direction parallel to the axis of the end fittings. The number of flexing cycles shall be 100 cycles.



# Testing and Listings

## Underwriters Laboratory Testing — VNF.EX5269

Flexible Sprinkler Hose with Fittings

See General Information for Flexible Sprinkler Hose with Fittings

**FLEXHEAD INDUSTRIES**

EX5269

LOWLAND IND PARK

56 LOWLAND ST

HOLLISTON, MA 01746 USA

Model	Rated Pressure psig	Max Ambient Temp, °F	Nom Inlet by Outlet Size, in.	Assembly Length ft (mm)	Max No. of 90° Bends	Min Bend Radius, in.	Equivalent Length of 1 in. Schedule 40 Steel Pipe (C=120), ft	Flexibility Type
2024	175	300	1 by 1/2	2	3	3	11	Limited
2036	175	300	1 by 1/2	3	3	3	16	Limited
2048	175	300	1 by 1/2	4	4	3	24	Limited
2060	175	300	1 by 1/2	5	4	3	29	Limited
2072	175	300	1 by 1/2	6	4	3	35	Limited
2024	175	300	1 by 3/4	2	3	3	12	Limited
2036	175	300	1 by 3/4	3	3	3	18	Limited
2048	175	300	1 by 3/4	4	4	3	23	Limited
2060	175	300	1 by 3/4	5	4	3	29	Limited
2072	175	300	1 by 3/4	6	4	3	32	Limited
2024H	300	300	1 by 1/2	2	3	3	11	Limited
2036H	300	300	1 by 1/2	3	3	3	16	Limited
2048H	300	300	1 by 1/2	4	4	3	24	Limited
2060H	300	300	1 by 1/2	5	4	3	29	Limited
2072H	300	300	1 by 1/2	6	4	3	35	Limited
2024H	300	300	1 by 3/4	2	3	3	12	Limited
2036H	300	300	1 by 3/4	3	3	3	18	Limited
2048H	300	300	1 by 3/4	4	4	3	23	Limited
2060H	300	300	1 by 3/4	5	4	3	29	Limited
2072H	300	300	1 by 3/4	6	4	3	32	Limited
2024E	175	300	1 by 1/2	2	3	3	19	Limited
2036E	175	300	1 by 1/2	3	3	3	23	Limited
2048E	175	300	1 by 1/2	4	4	3	27	Limited
2060E	175	300	1 by 1/2	5	4	3	32	Limited
2072E	175	300	1 by 1/2	6	4	3	35	Limited
2024E	175	300	1 by 3/4	2	3	3	18	Limited
2036E	175	300	1 by 3/4	3	3	3	23	Limited
2048E	175	300	1 by 3/4	4	4	3	23	Limited
2060E	175	300	1 by 3/4	5	4	3	29	Limited
2072E	175	300	1 by 3/4	6	4	3	32	Limited
2024HE	300	300	1 by 1/2	2	3	3	19	Limited
2036HE	300	300	1 by 1/2	3	3	3	23	Limited
2048HE	300	300	1 by 1/2	4	4	3	27	Limited
2060HE	300	300	1 by 1/2	5	4	3	32	Limited
2072HE	300	300	1 by 1/2	6	4	3	35	Limited
2024HE	300	300	1 by 3/4	2	3	3	18	Limited
2036HE	300	300	1 by 3/4	3	3	3	23	Limited
2048HE	300	300	1 by 3/4	4	4	3	23	Limited
2060HE	300	300	1 by 3/4	5	4	3	29	Limited
2072HE	300	300	1 by 3/4	6	4	3	32	Limited

These flexible sprinkler hose with fittings are intended to be installed in accordance with the manufacturer's installation instructions dated August 20, 2008.

Copyright © 2009 Underwriters Laboratories Inc.®

Reprinted from the Online Certifications Directory with permission from Underwriters Laboratories Inc.

The appearance of a company's name or product in this database does not in itself assure that products so identified have been manufactured under UL's Follow-Up Service. Only those products bearing the UL Mark should be considered to be Listed and covered under UL's Follow-Up Service. Always look for the Mark on the product.

## Testing and Certifications

### Loss Prevention Certification Board — Loss Prevention Standard LPS 1261\*

FlexHead® series 2000 stainless steel sprinkler connections

#### Hydrostatic Pressure

Flexible hose will be subjected to 4 times the maximum working pressure for a period of one hour. *FlexHead successfully passed this test.*

#### Elevated Temperature Test

Flexible hose will be subjected to elevated temperature of 122F (50C) for 90 days, then subjected to 4 times the maximum working pressure. *FlexHead successfully passed this test.*

#### Sulphuric Acid Test

Flexible hose will be subjected to 4 times the maximum working pressure after conditioning in sulphuric acid. *FlexHead successfully passed this test.*

#### Crushing Load Test

The flexible connection with the cover removed shall be subjected to a crushing load of 100kg applied evenly over a length of 50mm for 30s. The connection shall not collapse or show signs of permanent deformation in excess of 5% of any appropriate dimension measured before the test. *FlexHead successfully passed this test.*

#### Salt Spray Test

Flexible hose will be subjected to salt spray conditioning in accordance to BSEN 60068-2-53:1996 Test K6 Salt Mist Cyclic (Severity 1). Then it will be subjected to hydrostatic test 4 times maximum working pressure. *FlexHead successfully passed this test.*

#### S02 Conditioning Test

Flexible hose will be subjected to 4 times the maximum working pressure after completion of the S02 conditioning. *FlexHead successfully passed this test.*

#### Dry Pipe Fire Test

A flexible assembly shall be pressured with air to 3 bar for 3 minutes. The flexible hose assembly shall then be subjected to a fire test. The air pressure shall be kept constant by venting. The flexible hose must maintain integrity of the pipework throughout the test. *FlexHead successfully passed this test.*

#### Sprinkler head Activation Test

Flexible hose and bracketing system will be installed to installation instructions into a 600mm x 600mm ceiling tile. Sprinkler head will be activated at 12 bar (175 PSI) and maintain running pressure at 11 bar (160 PSI) for 2 minutes. The sprinkler head must remain in position. *FlexHead successfully passed this test.*

#### Pressure Loss Test

To determine the effect of the flexible hose to the discharge coefficient of the sprinkler, the average friction loss through the flexible hose shall be equated to the theoretical length of nominal 1" diameter schedule 40 sprinkler pipe which would produce same amount of friction loss. *Please see friction loss table.*

\* Condensed Summary — Please see approval standard for full testing and approval criteria.

# Loss Prevention Certification Board



APPENDIX TO CERTIFICATE NO. 764a

**FLEXHEAD INDUSTRIES INC.**  
56 Lowland Street, Holliston, MA 01746, USA

Model	Length (mm)	Nominal Size / Connection		Max. Working Pressure (bar)	LPCB Ref. No.
		Supply	Outlet		
2024	600	R1 (1" NPT) or (1" BSPT) External thread	Rc½ or Rc¾ (½" or ¾" NPT) or (½" or ¾" BSP Internal thread	12	764a/01
2036	900				
2048	1200				
2060	1500				
2072	1800				
2024H	600	R1 (1" NPT) or (1" BSPT) External thread	Rc½ or Rc¾ (½" or ¾" NPT) or (½" or ¾" BSP Internal thread	20	764a/02
2036H	900				
2048H	1200				
2060H	1500				
2072H	1800				

See table footnotes on page 3

This certificate is valid until withdrawn by LPCB.  
To check the validity and the authenticity of this certificate please visit our website [www.RedBookLive.com](http://www.RedBookLive.com) or contact us.

Signed on behalf of the LPCB

Date of Issue 21 June 2006

Name: Simon Bird

LPCB is part of BRE Certification Ltd. Garston, Watford WD25 9XX. Tel +44 (0)1923 654100  
Fax +44 (0)1923 654603 [www.RedBookLive.com](http://www.RedBookLive.com)

This certificate remains the property of BRE Certification Ltd and is issued subject to terms and conditions and is maintained and held in force through regular surveillance activities.

**PRE-APPROVAL OF ANCHORAGE**  
**FOR FIXED HOSPITAL**  
**EQUIPMENT**



**Application No. OPA-0672**  
**FM APPROVAL AND UL FIRE SPRINKLER CONNECTIONS**

has been examined for conformance to the current requirements adopted by the Office of Statewide Health Planning and Development, Facilities Development Division.

Signed this Thursday, August 12, 2004.

STATE OF CALIFORNIA, HEALTH AND HUMAN SERVICES AGENCY  
OFFICE OF STATEWIDE HEALTH PLANNING AND DEVELOPMENT  
FACILITIES DEVELOPMENT DIVISION

  
Program Administrator

This approval must be renewed every three (3) years. Other conditions requiring renewal are listed below:

1. Changes in the applicable codes and regulations.
2. Changes in the manufactured product (fixed equipment).
3. Changes in the methods of anchorage or anchorage devices.

List of Approved Documents:

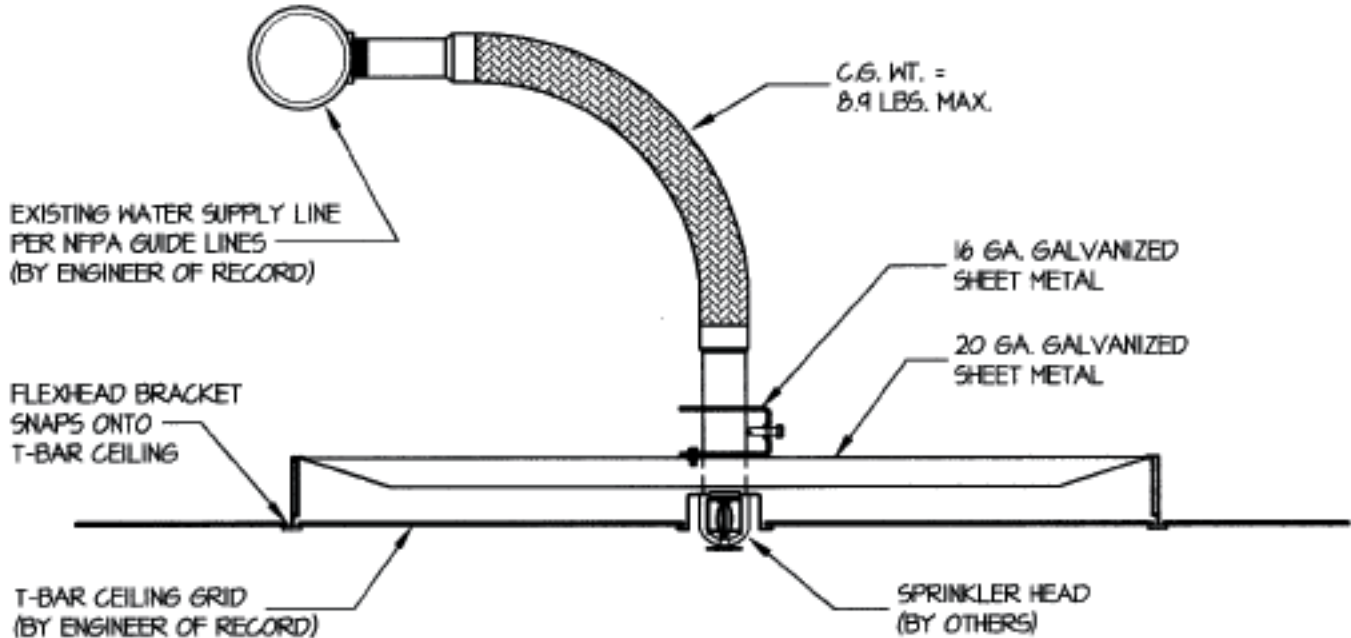
- Sheet Nos. Sheet 1 of 2 through Sheet 2 of 2

<b>FLEXHEAD INDUSTRIES</b>	DES. <b>R. LA BRIE</b>	SHEET <b>1</b>  OF <b>2</b> SHEETS
	JOB NO. <b>11-0441</b>	
<b>FLEXHEAD SPRINKLER CONNECTIONS</b> <b>MODEL # 2024, 2036, 2048, 2060, 2072</b>	DATE <b>8/10/04</b>	

SEISMIC ANCHORAGE PRE-APPROVED DETAIL

CEILING MOUNT

**Office of Statewide Health Planning and Development**  
**ANCHORAGE PRE-APPROVAL**



**ELEVATION**

GENERAL NOTES:

- FORCES ARE DETERMINED PER 2001 CBC SECTION 1632A,  $C_a = 0.6$ ,  $R_p = 1.0$ ,  $I_p = 1.5$ ,  $R_p = 3.0$   
 HORIZONTAL FORCE ( $V_H$ ) =  $0.94W$   
 VERTICAL FORCE ( $V_V$ ) =  $0.33(V_H)$
- ENGINEER OF RECORD FOR THE BUILDING SHALL PROVIDE SUPPORT STRUCTURE DESIGNED TO SUPPORT WEIGHTS AND FORCES SHOWN.



Note: OSHPD does not currently enforce expiration dates. All pre-approvals are valid regardless of expiration.

333 Plimpton Road  
Northbrook, Illinois 60062-2095  
United States Country Code (1)  
(847) 272-8800  
FAX No. (847) 272-2000  
<http://www.ul.com>



June 21, 2001

FlexHead Industries  
Mr. Norm MacDonald  
56 Lowland St.  
Holliston, MA 01746

Our Reference: File EX5269  
Subject: FlexHead Flexible Sprinkler Hose Fittings Installed Onto Dry Wall Ceiling Grid

Dear Mr. MacDonald:

This letter is in regard to the subject.

Base upon review of the FlexHead UL Listed flexible sprinkler hose fitting system, installation onto a dry wall ceiling grid is acceptable when the ceiling-mounted bracket is screwed to a rigid surface. Self-tapping screws are used to affix the FlexHead mounting bracket to the surface, using the four ports provided which are pre-drilled onto the mounting bracket.

Very truly yours,

EMIL W. MISICHKO (Ext. 42036)  
Engineering Group Leader  
Conformity Assessment Services  
Department 3011CNBK  
[Emil W. Misichko@us.ul.com](mailto:Emil.W.Misichko@us.ul.com)

A not-for-profit organization  
dedicated to public safety and  
committed to quality service



## National Fire Protection Association

1 Batterymarch Park, Quincy, MA 02169-3471  
Phone: 617-770-3000 • Fax: 617-770-3754 • www.nfpa.org

November 15, 2006

Mr. Norman MacDonald  
President  
FlexHead Industries, Inc.  
56 Lowland Street  
Holliston, MA 01746

Fax: 508-893-6020

Dear Mr. MacDonald,

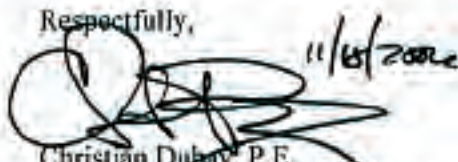
This letter is in response to your email dated November 13, 2006 which discussed listed flexible sprinkler hoses, specifically FlexHead. Your question relates to the acceptability of listed technology which was not specifically addressed in previous editions of NFPA 13, including the 1999 and 2002 editions.

NFPA 13, 1999 Section 1-2 and NFPA 13, 2002 Section 1.6 provide specific text that addresses new technology. It is the intent of the current and previous editions of NFPA 13 to allow the use of listed technologies where they are not specifically addressed in NFPA 13. The base requirement is that they be installed in compliance with all of the listing requirements and manufacturers' instructions. These statements have been provided by the technical committees to address the very situation that you have described. In essence, where a new technology is developed, tested and listed as acceptable for automatic fire sprinkler use it can be utilized in accordance with NFPA 13 with no additional requirements other than those in the listing and manufacturers' instructions.

In summary it is the intent of NFPA 13 to permit the use of technologies, equipment and materials not specifically addressed in NFPA 13 where they are specifically listed for fire sprinkler use and where they have been installed in accordance with the listing requirements and the manufacturers' instructions.

Please be aware that this response does not constitute a Formal Interpretation as explained in the Important Notice below.

Respectfully,

  
Christian Dubay, P.E.  
Principal Fire Protection Engineer  
NFPA 13 Staff Liaison

File: NFPA 13

**Important Notice:** This correspondence is not a Formal Interpretation issued pursuant to NFPA regulations. Any opinion expressed is the personal opinion of the author, and does not necessarily represent the official position of the NFPA or its Technical Committees. In addition, this correspondence is neither intended, nor should be relied upon, to provide professional consultation or services.



NYC Department of Buildings  
280 Broadway, New York, NY 10007  
Patricia J. Lancaster, FAIA, Commissioner

Donald Gottfried, P.E.  
Director, MEA Division  
212.566.3282  
212.566.3840 fax  
donaldg@buildings.nyc.gov

Mr. Peter MacDonald.  
Flexhead Industries.  
56 Lowland Street.  
Holliston, MA. 01746

Date: January 10, 2004.

Dear Applicant:

Enclosed is a final official signed copy of MEA acceptance of your product(s), MEA 261-99-E, which you may use as proof of your product(s) acceptance in New York City. Vol. 3.

This document together with proper labeling and installation in accordance with New York City Building Code will enable the inspector to know that the product(s) installed is (are) legal.

All shipments and deliveries of accepted materials to the job site are required to be labeled or tagged in accordance with the format below:

Accepted For Use  
City of New York  
Department of Buildings  
MEA 261-99-E, Vol. 3

Company Name

Very truly yours,

Donald Gottfried, P.E.  
Director  
Materials and Equipment Acceptance Division



## Limited Warranty

FlexHead Industries, Inc. warrants that its products will be free from defects in materials and workmanship under normal conditions of use and service for a period of one year from date of sale. Our obligation under this warranty is limited to repairing or replacing any product that is returned to us with transportation charges prepaid within one year after the date of original sale and that our examination shows to our satisfaction to have been defective in materials or workmanship under normal conditions of use and service. The decision as to whether to repair or to replace any product shall be made by us, and any repair shall be made at our facility.

Notwithstanding the foregoing, the following are specifically excluded from the coverage of this warranty:

(a) the sprinkler head of any FlexHead Industries, Inc. product, but FlexHead Industries, Inc. hereby assigns to the original purchaser of any such product the right to enforce the warranty, if any, issued by the manufacturer of such sprinkler head; (b) defects resulting from ordinary wear and tear, including, without limitation, the replacement of the so called poly bag components of any FlexHead Industries, Inc. product; (c) products that have been altered in any manner by the buyer or by anyone other than FlexHead Industries, Inc.; (d) products that have been subjected to misuse, abusive use, or damage by accident or casualty; (e) products that have been installed or used in a manner contrary to our specifications, instructions or recommendations, (f) products that have been installed or used in a manner that is not in compliance with all applicable requirements of any code, law, regulation or rule of any federal, state or local governmental or industry authority; and (g) products that have not been inspected and maintained in accordance with our

specifications, instructions or recommendations, including, without limitation, our recommendations as to following the inspection and maintenance standards published by Factory Mutual Research Corporation (FMRC) and the National Fire Protection Association (NFPA); and (h) products that have been affected by Microbiologically Influenced Corrosion (MIC). This warranty is not assignable and shall benefit only the original purchaser of a FlexHead Industries, Inc. product. If any provision hereof or any portion of any provision shall be held invalid, the remainder of this Limited Warranty shall not be affected thereby, and all provisions of this Limited Warranty shall remain valid and in full force and effect to the fullest extent permitted by law. THIS WARRANTY IS IN LIEU OF ALL IMPLIED WARRANTIES, INCLUDING, BUT NOT LIMITED TO, WARRANTIES OF MERCHANTABILITY AND WARRANTIES OF FITNESS FOR A PARTICULAR PURPOSE. NOTWITHSTANDING ANY PROVISION TO THE CONTRARY HEREIN OR ANY APPLICABLE LAW TO THE CONTRARY, IN NO EVENT SHALL FLEXHEAD INDUSTRIES, INC. BE LIABLE FOR INCIDENTAL OR CONSEQUENTIAL DAMAGES UNDER ANY CIRCUMSTANCES WHATSOEVER, WHETHER ARISING FROM ANY BREACH OF THIS LIMITED WARRANTY OR OTHERWISE ARISING FROM OR IN CONNECTION WITH THE USE OR OPERATION OF, OR ANY DEFECT IN, ANY FLEXHEAD INDUSTRIES, INC. PRODUCT, OR OTHERWISE. The risk of damages from any breach of warranty with respect to injury to any person will be born by the purchaser of FlexHead Industries, Inc. product.

# FlexHead commercial fire sprinkler connections

## Your security is our business.

FlexHead Industries was founded in 1992 to help engineers, builders and owners increase the safety of their buildings. Our patented sprinkler connection technologies show that it's possible to comply with codes cost-effectively. We're proud to help reduce the risks of property damage and loss of life in a wide variety of buildings, domestically and world-wide.

### FlexHead manufactures sprinkler connections for all types of applications including:



#### Commercial

- Government
- Hospitals
- Offices
- Restaurants
- Retail
- Schools

#### Cleanrooms

- Biotechnology
- Electronics
- High-end commercial ceilings
- Pharmaceuticals
- Semiconductors

#### Exhaust ducts

- Aerospace
- Automotive
- Biotechnology
- Electronics
- Forest products/paper pulp
- Laboratories
- Petrochemical
- Pharmaceuticals
- Restaurants
- Semiconductors
- Steel manufacturers

#### Institutions

- Concrete penetrations for sidewall and pendant applications
- Correctional centers
- Mental health facilities

### Seismically qualified.

*FlexHead connections allow for independent movement between sub-mains and ceilings. They're the only flexible sprinkler connection to be qualified for use in Seismic Design Categories C, D, E and F.*

# FLEXHEAD<sup>®</sup>

INDUSTRIES 

*The best idea in sprinkler systems since water*



U.S. and international patents pending: #6,123,154, #6,119,784, #6,752,218, #7,032,680, #6,488,097.

The FlexHead name and logo are trademarks of FlexHead Industries.

FGG/BM/CZ<sup>®</sup> System Compatible indicates this product has been tested and is monitored on an ongoing basis to assure chemical compatibility with FlowGuard Gold<sup>®</sup>, BlazeMaster<sup>®</sup>, and Corzan<sup>®</sup> pipe and fittings.

FGG/BM/CZ<sup>®</sup>, FlowGuard Gold<sup>®</sup>, BlazeMaster<sup>®</sup>, and Corzan<sup>®</sup> are registered trademarks of Noveon IP Holdings Corp.

USGBC<sup>®</sup> and LEED<sup>®</sup> are registered trademarks of the U.S. Green Building Council.

56 Lowland Street  
Holliston, Massachusetts 01746  
toll-free 800-829-6975  
(508) 893-9596  
fax (508) 893-6020  
info@flexhead.com  
www.flexhead.com

1M/SDP/03-09