

Beaver Creek Environmental Services, Inc.

March 20, 2023

M. Rick Velasquez
Cimco Puyallup
2315 Inter Ave.
Puyallup, WA 98372

c/o Larson Engineers

RE: Wetland and Drainage Corridor Evaluation and Delineation
Parcels # 2105200140, 2315 Inter Ave., City of Puyallup, WA

M. Velasquez,

As requested, we have evaluated your property for jurisdictional wetlands, streams, and required buffers. The property is located at 2315 Inter Ave., City of Puyallup. The project site is in an industrial area of the City of Puyallup.

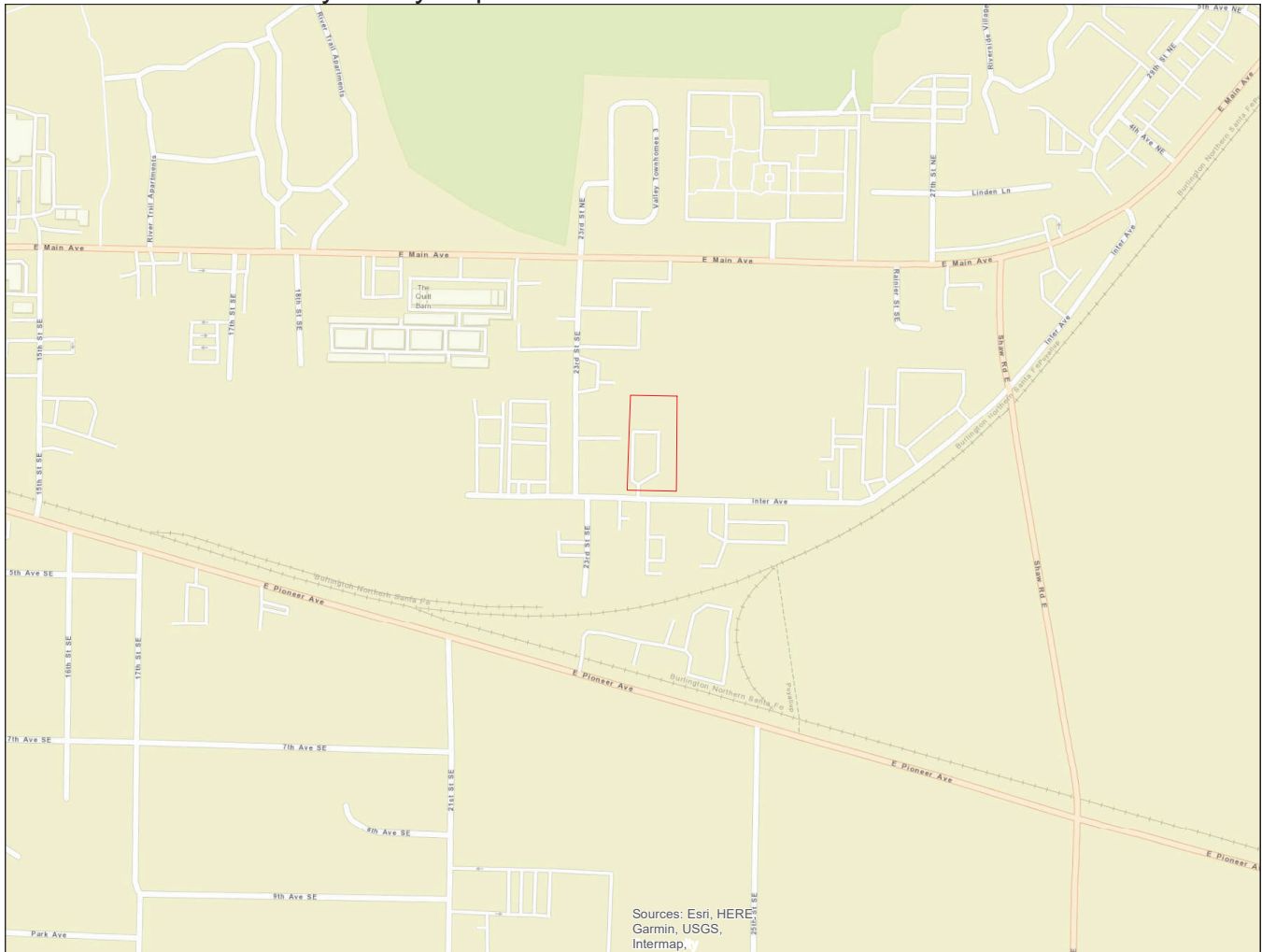

Figure 1. Vicinity Map

----- POB 731695 • Puyallup WA 98373 -----
(253) 732-6515 MHeckert@Q.com

Location and Existing Conditions

This site is rectangular, approximately 1.86 ac. The majority of the site is developed to a warehouse distribution center. There is a stormwater drain and detention facility in the northwest ¼ of the site. Commercial parcels surround the site.



Figure 2. Existing condition

Methodology

The site visit was conducted on March 15, 2023. A combination of field indicators, including: soils, vegetation, and hydrology, were used to determine whether wetlands were present. The methodology used to identify jurisdictional wetlands is described in the *Corps of Engineers (CoE) Wetland Delineation Manual - 2010 Western Mountains, Valleys, and Coast (WMVC) Regional Supplement (CoE Manual)*, Washington State Wetland Rating System for Western Washington (WSWRS), and City of Puyallup Code.

Wetlands are transitional areas between aquatic and upland habitats. In general terms, wetlands are lands where the extent and duration of saturation with water is the primary factor determining the nature of soil development and the types of plant and animal communities living in the soil and on its surface (FGDC, 2013). Wetlands are generally defined as *"those areas that are*

inundated or saturated by surface water or ground water at a frequency and duration sufficient to support, and that under normal circumstances do support, a prevalence of vegetation typically adapted for life in saturated soil conditions." (Pierce County Title 18E).

Wetlands exhibit three (3) essential characteristics, all of which must be present for an area to meet the established criteria within the CoE Manual. These essential characteristics are:

Hydrophytic Vegetation: Meaning a predominance of plants that are typically adapted for life in saturated soils,

Hydric Soil: Meaning soils that are saturated, flooded, or ponded long enough during the growing season to develop anaerobic conditions in the upper horizons, and;

Wetland Hydrology: Meaning permanent or periodic inundation, or soil saturation to the surface, at least seasonally.

Streams are delineated by identification of the Ordinary High-Water Mark (OHWM). The definition of the OHWM as defined by the Washington State Department of Ecology as a part of the Shoreline Management Act is:

"the mark on all lakes, streams, and tidal water that will be found by examining the bed and banks and ascertaining where the presence and action of waters are so common and usual, and so long continued in all ordinary years, as to mark upon the soil a character distinct from that of the abutting upland, in respect to vegetation as that condition exists on June 1, 1971, as it may naturally change thereafter, or as it may change thereafter in accordance with permits issued by a local government or the department: Provided, That in any area where the ordinary high water mark cannot be found, the ordinary high water mark adjoining salt water shall be the line of mean higher high tide and the ordinary high water mark adjoining fresh water shall be the line of mean high water".

Existing Documentation

National Wetland Inventory (NWI) resources (fig. 3) identifies no wetlands on the project site. Offsite to the west NWI identifies an extensive linear wetland complex, which is the riparian corridor of Deer Creek.



Figure 3. NWI map

The City of Puyallup wetlands map (Fig. 4) located no wetlands or streams on, or adjacent to, the site. Pierce County Hydro describes the stream corridor and associated wetlands of Deer Creek approximately 700 ft. west of the southwest corner of the site.

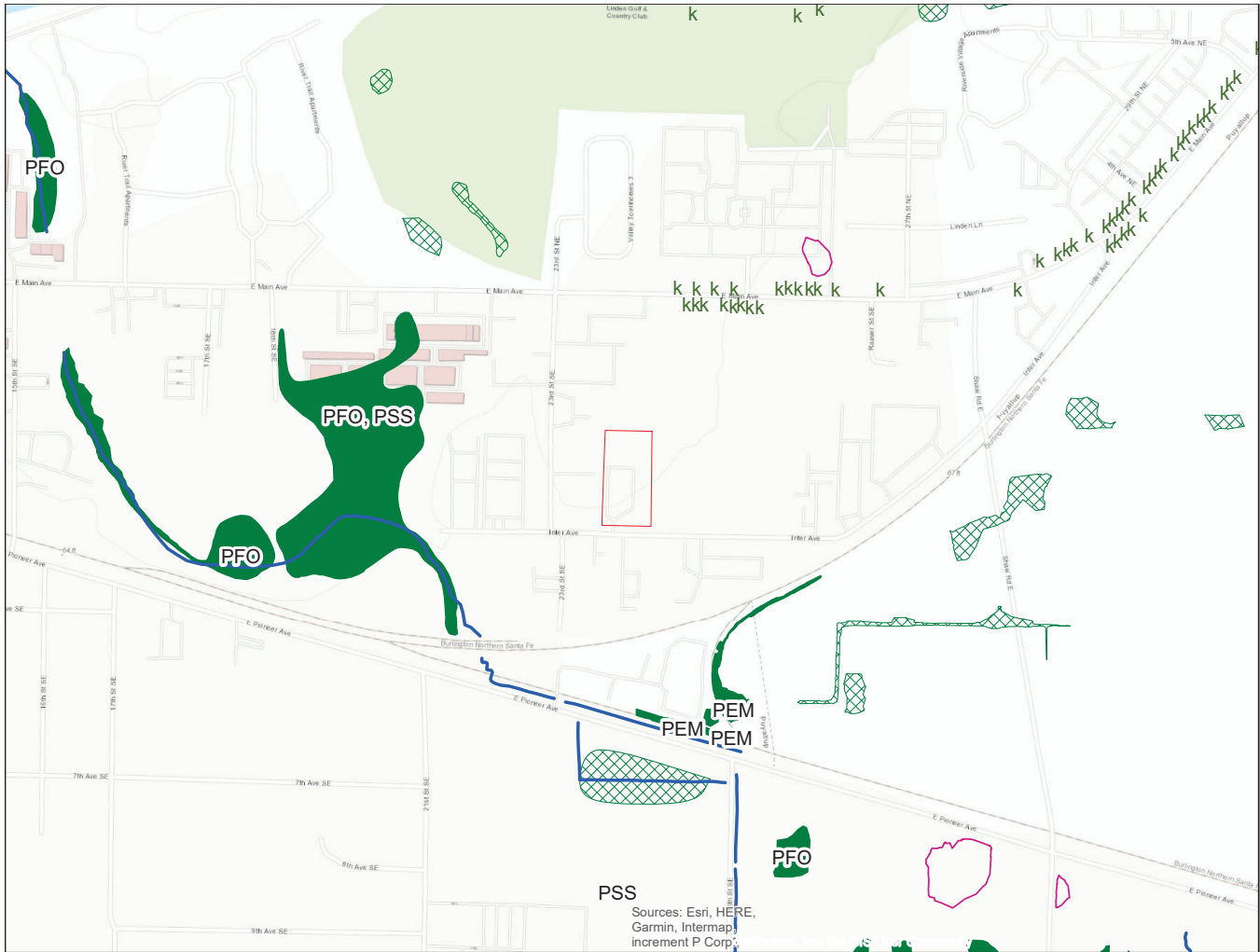

Figure 4. Puyallup Wetland & Stream Map

The soil in the site is Briscot loam, designated as “hydric” in Pierce County.

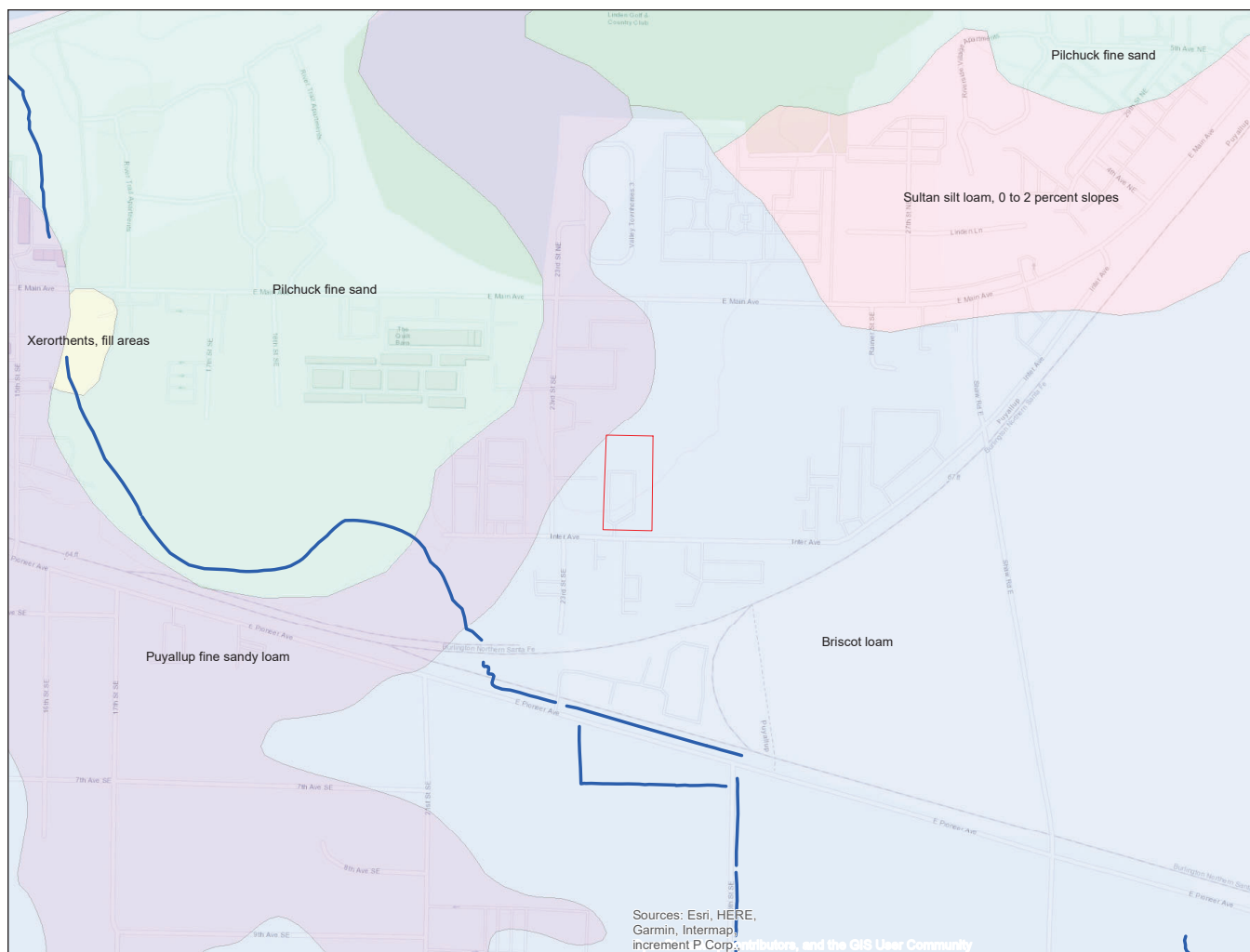

Figure 5. NRCS soil map

Previous Delineation

An *Environmentally Critical Areas Assessment* was completed on the adjacent parcel east in November 22, 2022 (City file). This assessment determined there was a Cat. 4 Wetland in the north of the site. This wetland was determined to be under size threshold for regulation and unregulated. City of Puyallup accepted and approved this determination.

A Critical Areas assessment was conducted on the parcel adjacent northeast in 2022 (Parcel # 0420264065). This study determined no wetlands in proximity to the site.

Field Observations

Onsite assessment activities encompassed the entire project site, and 315 feet from the boundary in all directions, as visible. The site is in an urban area of the city. The site is developed as a warehouse, with impermeable surface covering 70% of the parcel. The northern portion of the parcel is undeveloped.

West of the warehouse a storm ditch collects surface runoff and directs it to a detention pond in the northwest corner of the site. The remainder of the north portion is undeveloped and recently cleared of blackberry. The plant community throughout the site was identified as non-hydrophytic in character (i.e., typical of uplands). Field indicators of wetland hydrology were also absent. Soil samples thru the site were silt loam overlain with fill.

No area within 315 ft. was observed to meet the criteria for designation as wetland.

FINDINGS AND CONCLUSIONS

Onsite assessment was completed on March 15, 2023 following the methods and procedures defined within the Wash. Manual, the CoE Manual, and the WDNR Forest Practice Rules.

This assessment identified that no area on the site, or within the immediate vicinity (315 feet) of the project site, exhibited all three of the established criteria for designation as "wetland". The entire site would be best defined as urban industrial area.

No area on-site or immediately upslope exhibited evidence of seeps or springs.

No area was identified onsite that would meet the criteria for designation as a "stream."

The wetland on the parcel east was determined non-jurisdictional by City of Puyallup.

The drainage ditch and detention pond are features required to be installed at the original development (see survey, attached), and drains through a manhole to the City storm drain system. It is a required development feature and not a regulated critical area.

Thank you for allowing BCES the opportunity to assist with this project. Should you have any questions or require additional assistance please call me at 253 732-6515.

Respectfully Submitted,

Mark Heckert

Mark Heckert

PREPARER CREDENTIALS

Wetland assessment prepared by Mark Heckert Managing Principal of Beaver Creek Environmental Services, Inc.. Mark has an AAS in Fish & Wildlife Technology and a BS in Wildlife Science. Mark has 23 years' experience in wetland delineation, impact assessment, and mitigation planning throughout the Puget sound region. Mark has completed the US Army Corps of Engineering (CoE) wetland training, Washington State Wetland Rating System, and numerous individual courses in wetland function and management, is a Preferred Consultant in King & Pierce Counties and has authored 500+ accepted critical areas reports in 14 Puget Sound jurisdictions.

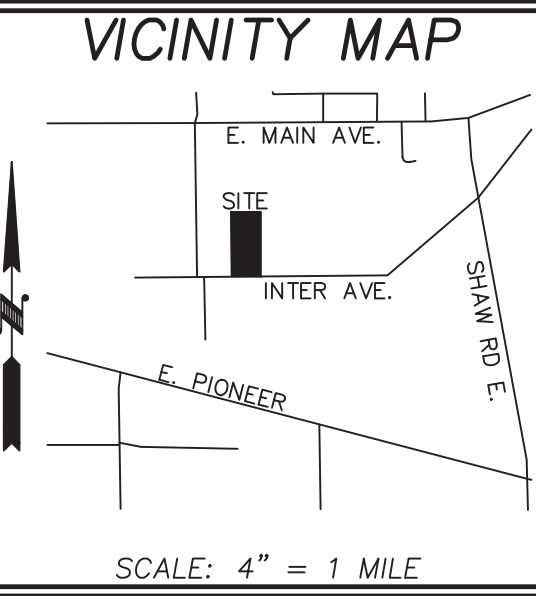

SHEET INDEX

C0.0	1 OF 7	COVER SHEET
C1.0	2 OF 7	T.E.S.C. & PLAN
C1.1	3 OF 7	T.E.S.C. SPECIFICATIONS
C2.0	4 OF 7	STORM PLAN
C2.1	5 OF 7	DETAILS AND SPECIFICATIONS
C2.2	6 OF 7	DETAILS AND SPECIFICATIONS
C2.3	7 OF 7	DETAILS AND SPECIFICATIONS

PARCEL NUMBER
2105200140

SITE ADDRESS
2315 INTER AVE, PUYALLUP, WA 98372

VELASQUEZ PROPERTY

NE 1/4, SW 1/4, SEC.26, TWN.20 N., RNG. 4 E., W.M.
COVER SHEET

FIRE HYDRANT/FDC LOCATION/ACCESS APPROVED

BY: CITY OF PUYALLUP
FIRE CODE OFFICIAL

DATE: _____

APPROVED

BY: CITY OF PUYALLUP
ENGINEERING DEPARTMENT

DATE: _____

NOTE: THIS APPROVAL IS VOID AFTER 180 DAYS FROM APPROVAL DATE. THE CITY WILL NOT BE RESPONSIBLE FOR ERRORS AND/OR OMISSIONS ON THESE PLANS. FIELD CONDITIONS MAY DICTATE CHANGES TO THESE PLANS AS DETERMINED BY THE FIRE CODE OFFICIAL.

NOTE: THIS APPROVAL IS VOID AFTER 180 DAYS FROM APPROVAL DATE. THE CITY WILL NOT BE RESPONSIBLE FOR ERRORS AND/OR OMISSIONS ON THESE PLANS. FIELD CONDITIONS MAY DICTATE CHANGES TO THESE PLANS AS DETERMINED BY THE DEVELOPMENT ENGINEERING MANAGER.

JOB NUMBER
9575

SCALE
HOR: 1"=40'
VERT: N/A

DESIGNED JLC
DRAWN
CHECKED GJM

PROPERTY DESCRIPTION

(PER DEED OF TRUST, AFN 201810030016)
LOT 7, ACKERSON'S ADDITION TO PUYALLUP, ACCORDING TO THE PLAT RECORDED IN VOLUME 8 OF PLATS, PAGE 25, RECORDS OF PIERCE COUNTY, WASHINGTON.

SITUATE IN THE COUNTY OF PIERCE, STATE OF WASHINGTON.

CONSTRUCTION NOTES:

- ▲ CONTRACTOR TO REMOVE AND RELOCATE FIRE HYDRANT ASSEMBLY AS SHOWN. SEE FIRE HYDRANT ASSEMBLY DETAIL ON SHEET RS2.
- ▲ CONTRACTOR TO ENSURE 0.5'(MIN) VERTICAL SEPARATION BETWEEN WATER AND STORMWATER LINES.
- ▲ CONTRACTOR TO REMOVE AND REPLACE EXISTING FENCING (AS NECESSARY) TO FACILITATE HYDRANT SPOOL EXTENSION CONSTRUCTION AS SHOWN.
- ▲ CONTRACTOR TO INSTALL 90° BEND FITTING IN WATER MAIN WITH THRUST BLOCKING PER CITY OF PUYALLUP REQUIREMENTS.

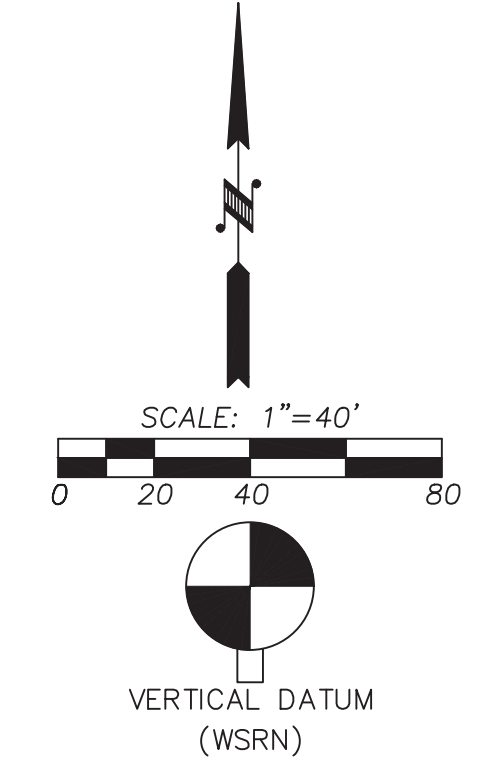
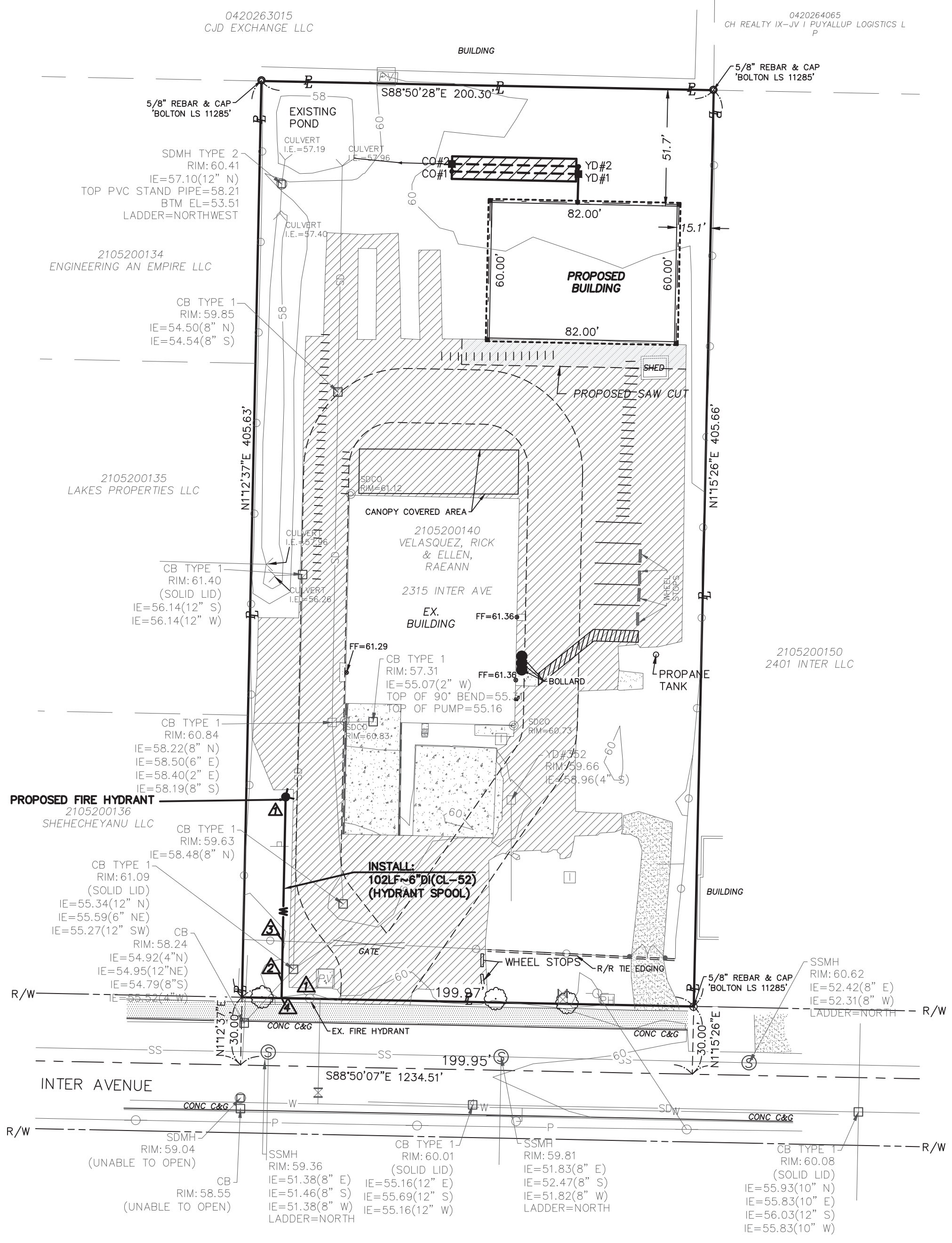

NAVD 88 ESTABLISHED USING GPS RTK ROVER CONSTRAINED TO THE WASHINGTON STATE REFERENCE NETWORK (WSRN) STATIONS

CONTOUR INTERVAL=1'
TOPOGRAPHY PREPARED BY LARSON & ASSOCIATES

HORIZONTAL DATUM
NAD 83/11 WASHINGTON SOUTH ZONE
ESTABLISHED USING GPS RTK ROVER CONSTRAINED TO THE WASHINGTON STATE REFERENCE NETWORK (WSRN) STATIONS

SURVEYOR'S REFERENCES

(P) ACKERSON'S 2ND ADDITION TO PUYALLUP, AFN 215387
(R1) RECORD OF SURVEY, 200801255002

LEGEND

- P — PROPERTY LINE
- 60 — EXISTING CONTOUR
- — — — RIGHT OF WAY
- W — EXISTING WATER MAIN (APPROX. LOCATION)
- SS — EXISTING SEWER MAIN
- SD — EXISTING STORM MAIN
- OP — EXISTING POWER LINE
- X — X — EXISTING WIRE FENCE
- ○ — ○ — EXISTING CHAINLINK FENCE
- SD — PROPOSED STORM LINE
- W — PROPOSED WATER LINE
- ■ — PROPOSED CATCH BASIN/YARD DRAIN
- □ — PROPOSED CLEAN OUT
- □ — PROPOSED WATER METER
- □ — EXISTING WATER METER
- □ — EXISTING IRR. BOX
- □ — EXISTING WATER VALVE
- □ — EXISTING FIRE HYDRANT
- □ — EXISTING CATCH BASIN
- □ — EXISTING STORM MANHOLE
- □ — EXISTING STORM C/O
- □ — EXISTING SEWER MANHOLE
- □ — EXISTING UTILITY POLE
- □ — EXISTING POWER VAULT
- ■ — EXISTING SIDEWALK
- ■ — EXISTING PAVEMENT
- ■ — EXISTING CONCRETE
- ■ — PROPOSED PAVEMENT GRIND/OVERLAY AREA
- ○ — EXISTING TREE

CONTRACTOR / DEVELOPER NOTE:

THE CONTRACTOR AND/OR DEVELOPER SHALL BE RESPONSIBLE FOR COORDINATING ALL REQUIRED MATERIAL TESTING, COMPACTION TESTING, AND APPLICABLE INSPECTIONS AS REQUIRED BY CITY OF PUYALLUP AND PRIVATE ENGINEER. THE CONTRACTOR SHALL SUPPLY CERTIFYING ENGINEER WITH DOCUMENTATION SIGNED BY A PROFESSIONAL SOILS AND/OR MATERIALS ENGINEER SHOWING THAT THE ROAD SECTION WAS BUILT ACCORDING TO THE RECOMMENDATIONS OF THE GEOTECHNICAL REPORT. THE BACKFILL MATERIAL MEETS MINIMUM CITY/STATE REQUIREMENTS. COMPACTION WAS ACHIEVED IN ALL TRENCHES AND ROAD SECTION, AND ALL CONSTRUCTION MATERIALS AND CONSTRUCTION METHODS SHOWN ON THESE PLANS HAVE BEEN FOLLOWED.

REVISION BLOCK

NO.	DATE	DESCRIPTION	BY

UTILITY CONFLICT NOTE:
CAUTION
THE CONTRACTOR SHALL BE FULLY RESPONSIBLE FOR VERIFYING THE LOCATION, AND DEPTH OF ALL EXISTING UTILITIES WHETHER SHOWN ON THESE PLANS OR NOT BY POTHOLES THE UTILITIES AND SURVEYING THE HORIZONTAL AND VERTICAL LOCATION PRIOR TO CONSTRUCTION. THIS SHALL INCLUDE CALLING UTILITY LOCATE @ B11 AND THEN POTHOLES ALL OF THE EXISTING UTILITIES AT LOCATIONS OF NEW UTILITY CROSSINGS TO PHYSICALLY VERIFY WHETHER OR NOT CONFLICTS EXIST. LOCATION OF SAID UTILITIES AS SHOWN ON THESE PLANS ARE BASED UPON THE UNVERIFIED PUBLIC INFORMATION AND ARE SUBJECT TO VARIATION. IF CONFLICTS SHOULD OCCUR, THE CONTRACTOR SHALL CONSULT THE PROJECT ENGINEER TO RESOLVE ALL PROBLEMS PRIOR TO PROCEEDING WITH CONSTRUCTION.

CALL BEFORE YOU DIG
THE CONTRACTOR SHALL BE FULLY RESPONSIBLE FOR THE LOCATION AND PROTECTION OF ALL EXISTING UTILITIES. THE CONTRACTOR SHALL VERIFY ALL UTILITY LOCATIONS PRIOR TO CONSTRUCTION BY CALLING THE UNDERGROUND LOCATE LINE AT B11 A MINIMUM OF 48 HOURS PRIOR TO ANY EXCAVATION.

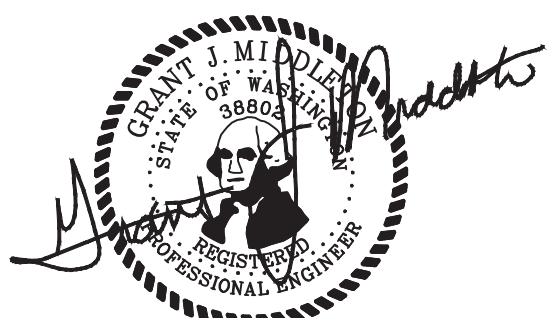

PROPOSED BY: RICK VELASQUEZ
 13615 122ND ST E
 PUYALLUP, WA 98374
 PH: (253) 224-4428

LARSON and ASSOCIATES
 surveyors, engineers & planners
 9027 PACIFIC AVENUE, SUITE 4
 TACOMA, WA 98444 (253) 474-3404

COVER SHEET

DATE: 3/14/2023
 DRAWING NO.: 9575BASE
 SHEET 1 OF 7