

City of Puyallup Development & Permitting Services ISSUED PERMIT Building Planning Engineering Public Works Fire Traffic

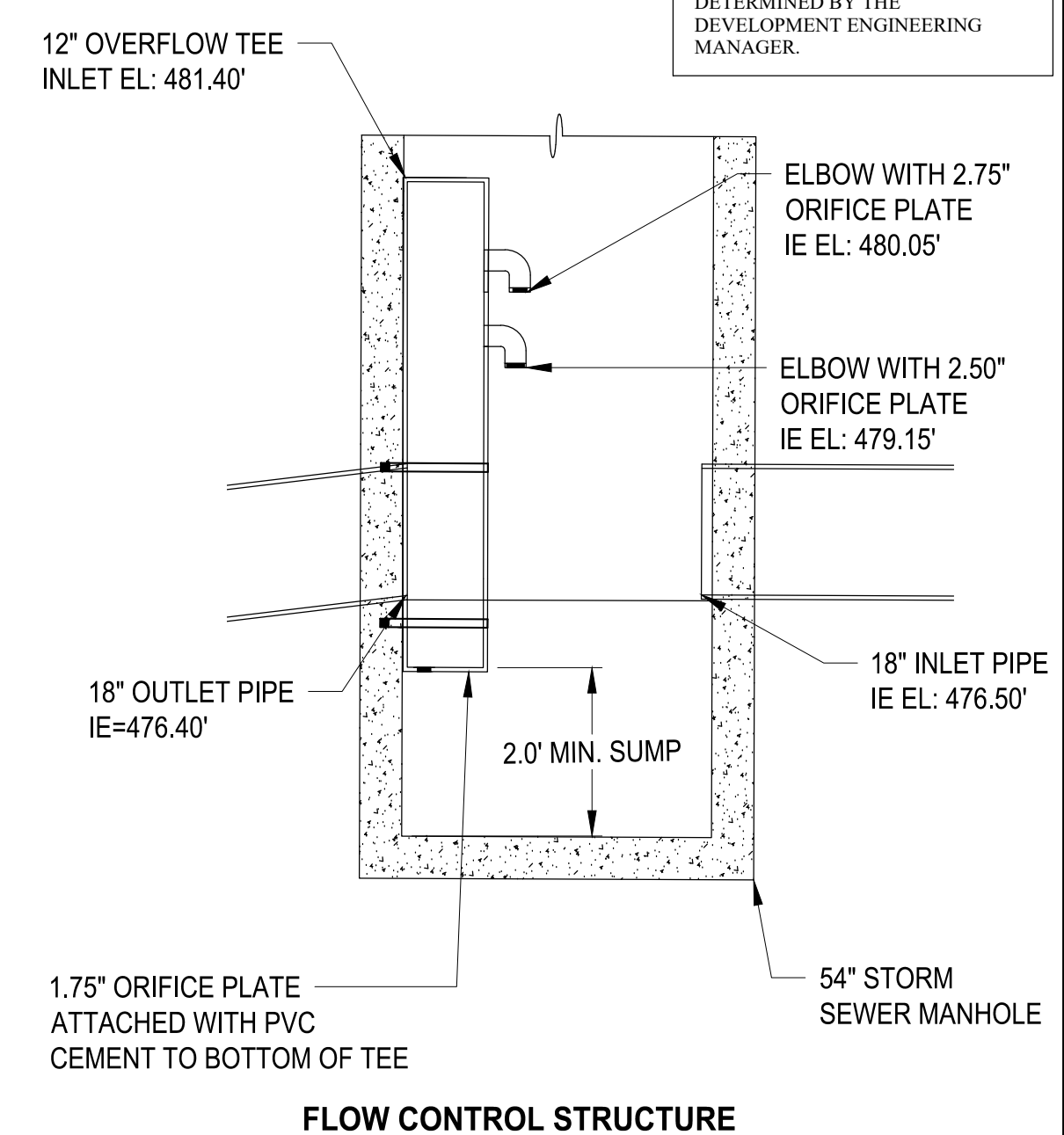
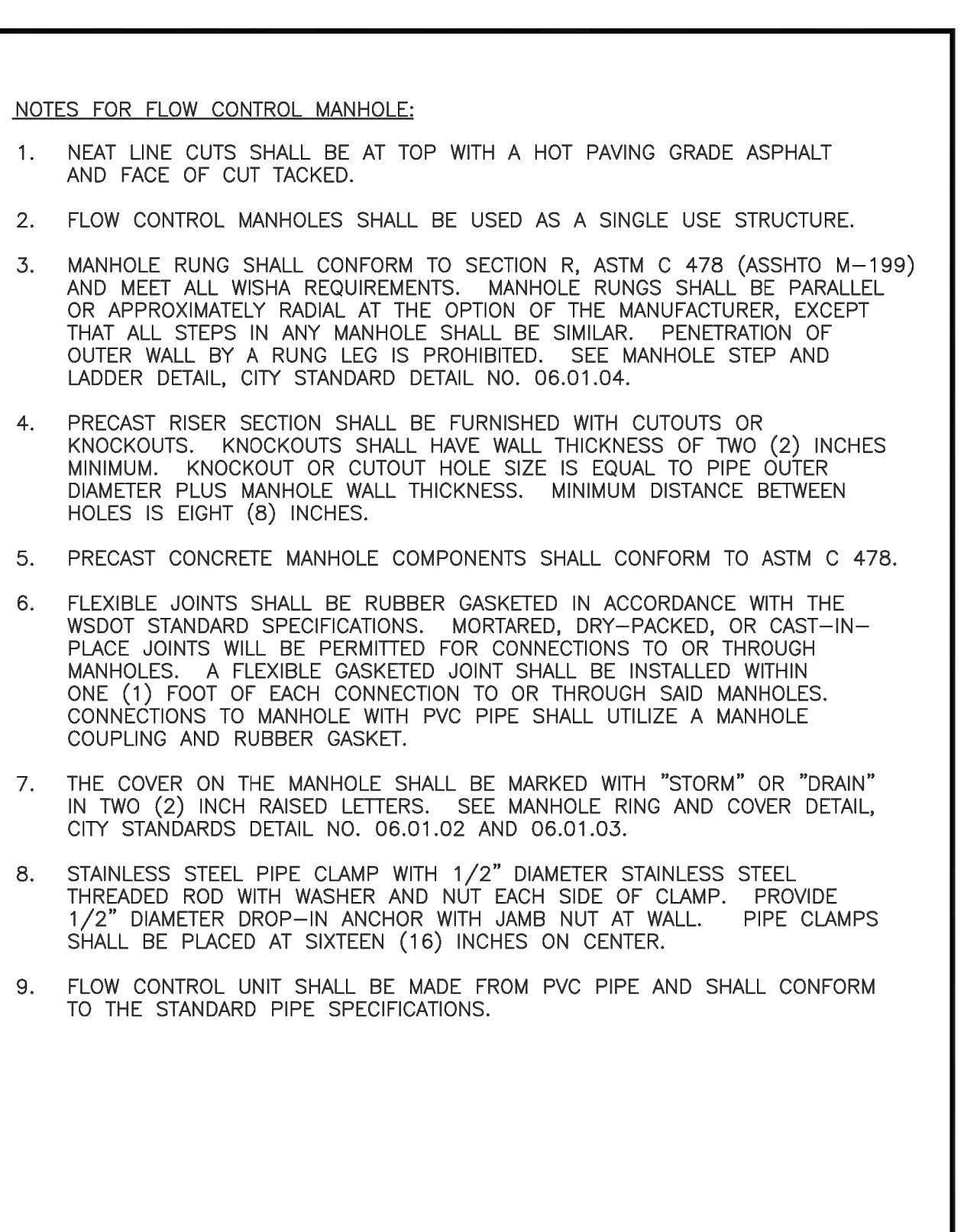
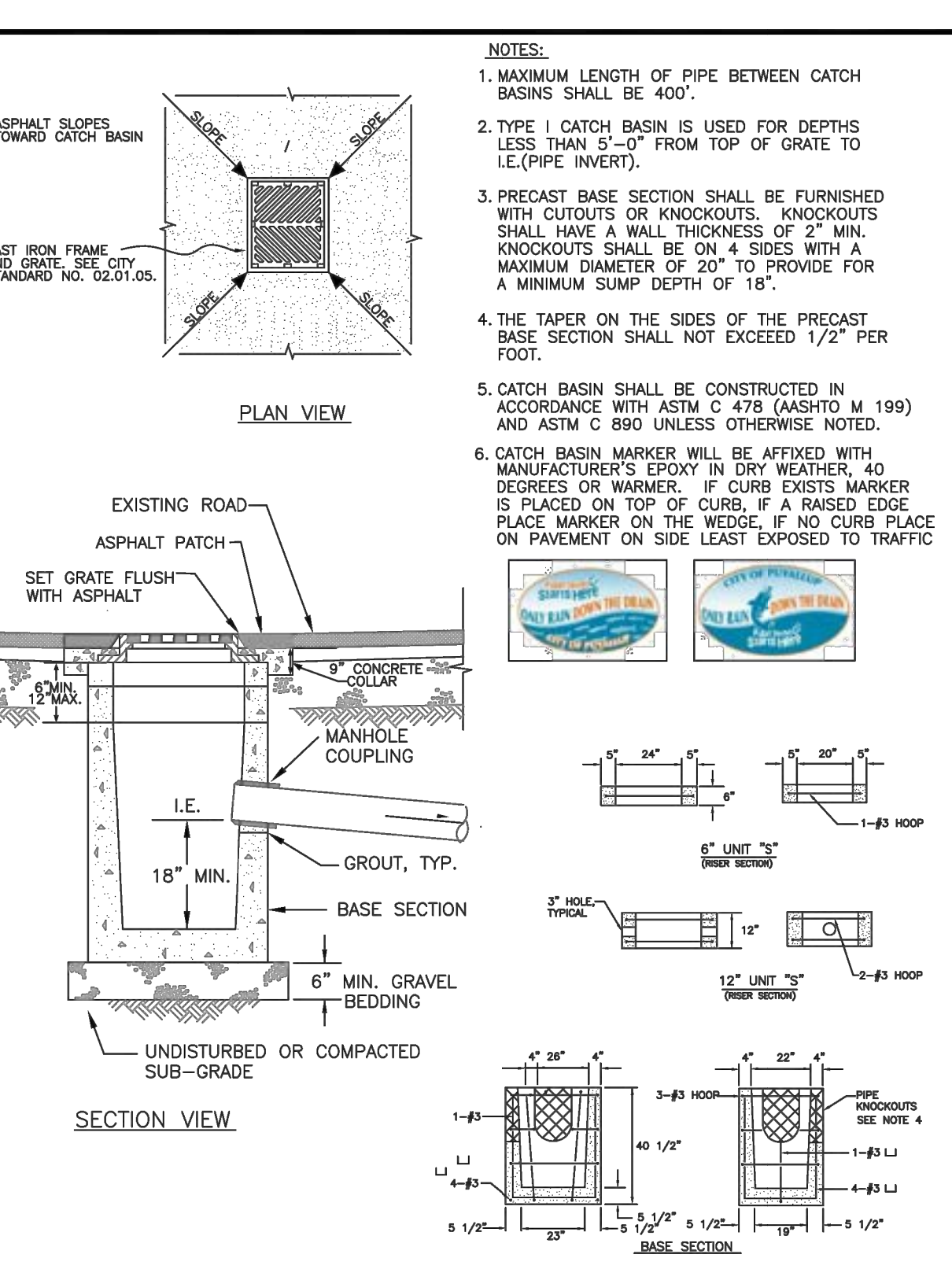
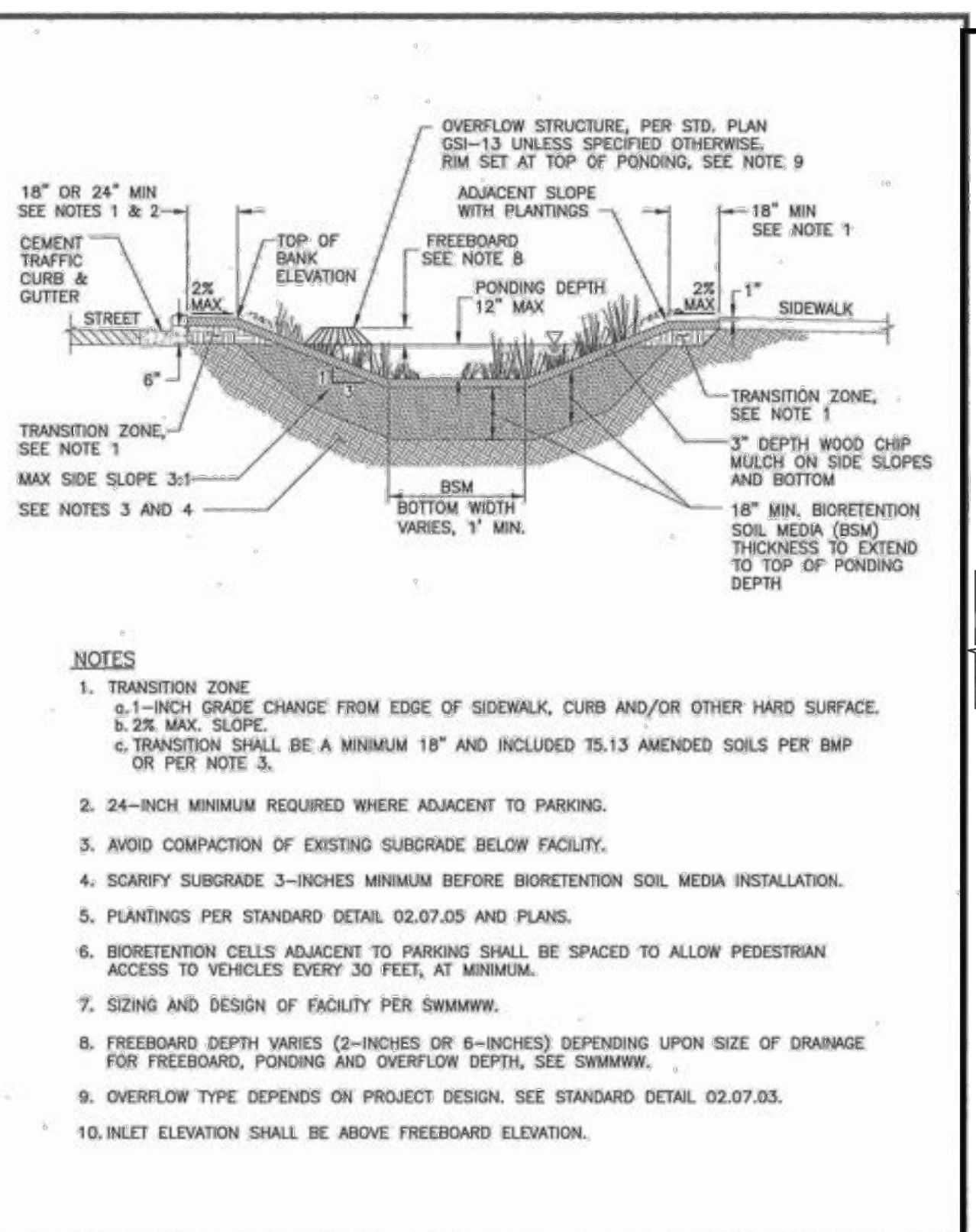
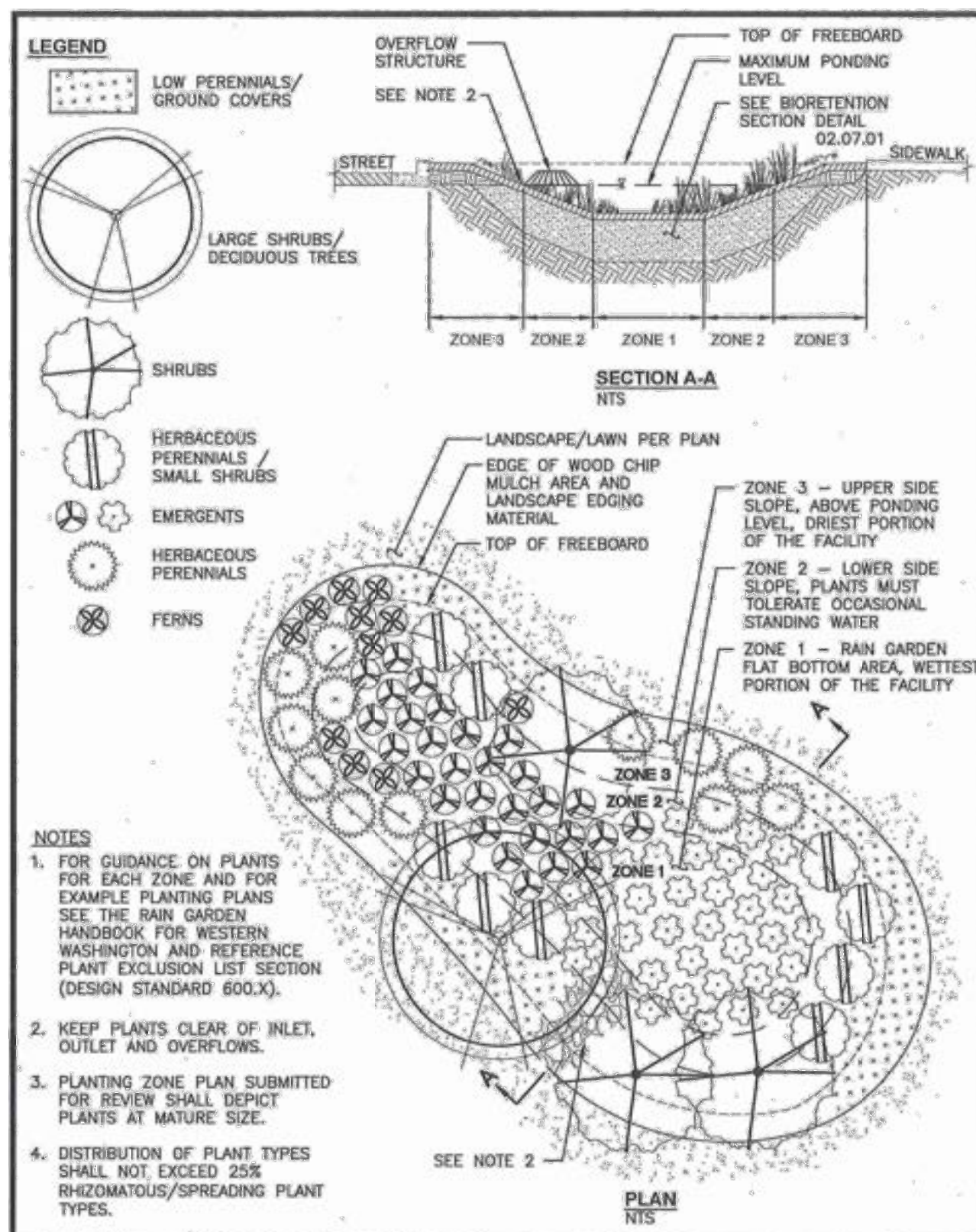

CITY OF PUYALLUP OFFICE OF THE CITY ENGINEER. Table with columns for project name, location, date, and engineer.

CITY OF PUYALLUP OFFICE OF THE CITY ENGINEER. Table with columns for project name, location, date, and engineer.

CITY OF PUYALLUP DEVELOPMENT ENGINEERING and PUBLIC WORKS DEPARTMENTS. Table with columns for project name, location, date, and engineer.

CITY OF PUYALLUP DEVELOPMENT ENGINEERING and PUBLIC WORKS DEPARTMENTS. Table with columns for project name, location, date, and engineer.

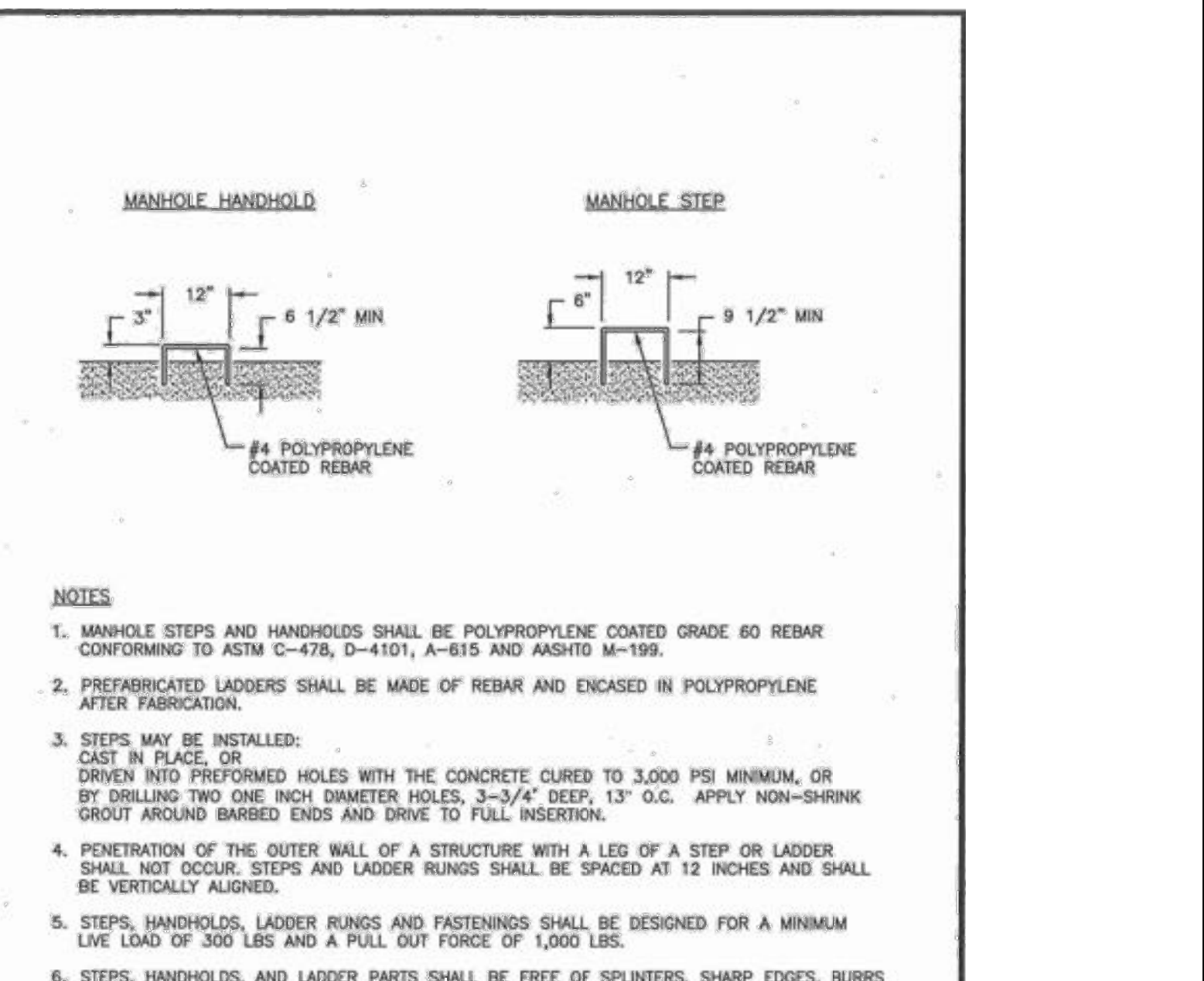
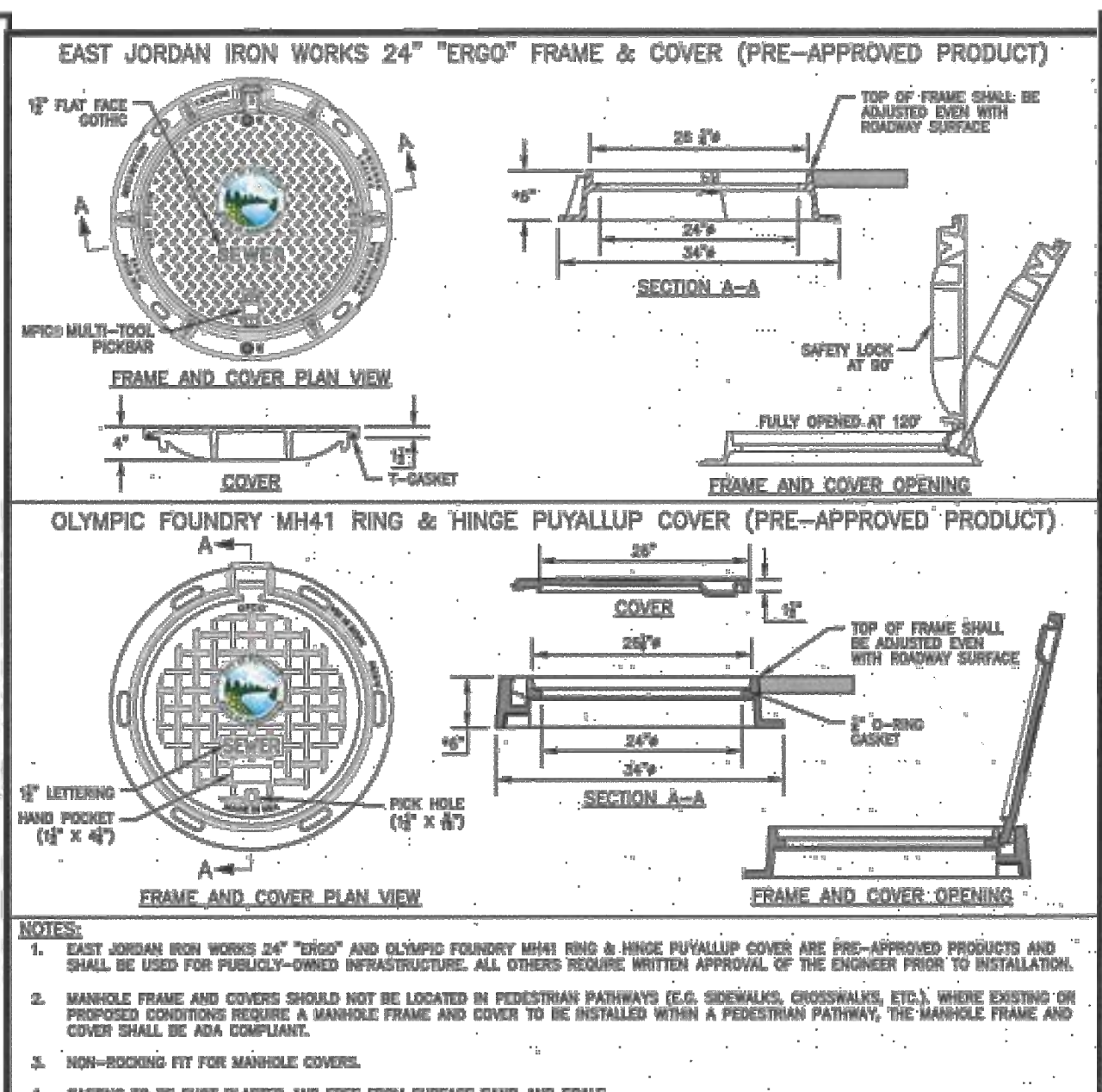
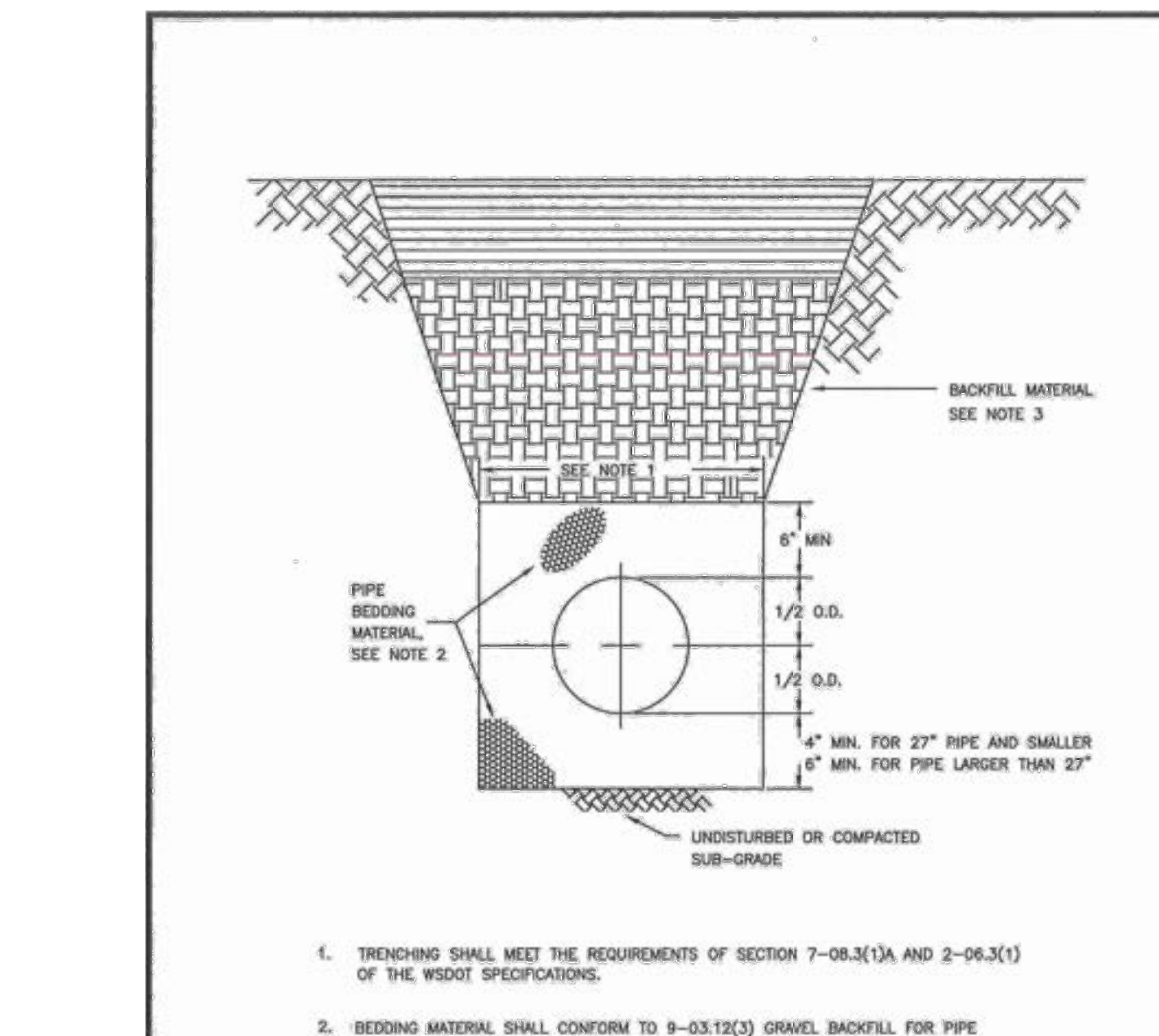
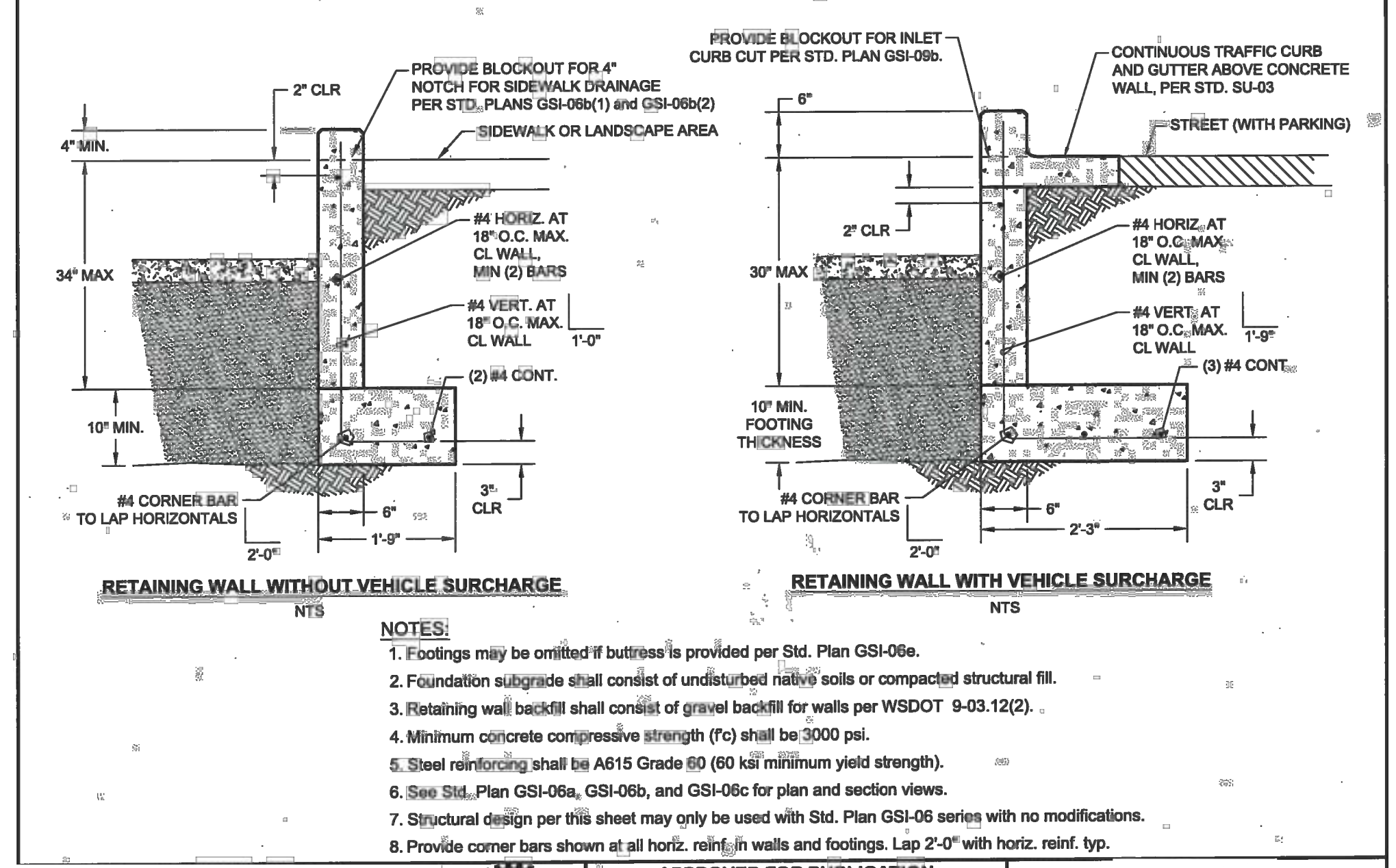

APPROVED FOR PUBLICATION stamp and WALLED BIORETENTION WALLS AND STRUCTURAL FOOTING STANDARD PLAN NO. GSI-06d.

GENERAL NOTE 1. WALLS OVER 48-INCHES FROM BOTTOM OF FOOTING TO SEPARATE WALL REQUIRE SEPARATE BUILDING PERMIT.

City of Puyallup Building ACCEPTED stamp with date and time.

PRRWF20230497

City of Puyallup Development & Permitting Services ISSUED PERMIT stamp with Building, Planning, Engineering, Public Works, Fire, and Traffic categories.

CITY OF PUYALLUP OFFICE OF THE CITY ENGINEER. Table with columns for project name, location, date, and engineer.

CITY OF PUYALLUP OFFICE OF THE CITY ENGINEER. Table with columns for project name, location, date, and engineer.

CITY OF PUYALLUP OFFICE OF THE CITY ENGINEER. Table with columns for project name, location, date, and engineer.

REVISIONS table with columns for revision number, date, by, and description.

ONE INCH AT FULL SCALE, IF NOT, SCALE ACCORDINGLY stamp with project name and date.

Parametrix ENGINEERING, PLANNING, ENVIRONMENTAL SCIENCES logo and contact information.

PROJECT NAME SOUTH HILL BUSINESS & TECHNOLOGY CENTER PARKING EXPANSION PUYALLUP, WA

STORM DRAINAGE STANDARD DETAILS SD-08 stamp with drawing number and date.

Vertical text on the left margin: PLOTTED BY: pettinus DATE: Thursday, July 28, 2022 11:39:35 AM