

THE APPROVED CONSTRUCTION PLANS, DOCUMENTS AND ALL ENGINEERING MUST BE POSTED ON THE JOB AT ALL INSPECTIONS IN A VISIBLE AND READILY ACCESSIBLE LOCATION.

FULL SIZED LEDGIBLE COLOR PLANS ARE REQUIRED TO BE PROVIDED BY THE PERMITEE ON SITE FOR INSPECTION

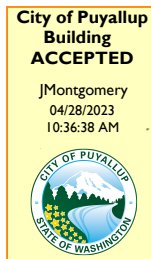

City of Puyallup
Development & Permitting Services
ISSUED PERMIT

Building	Planning
Engineering	Public Works
Fire	Traffic

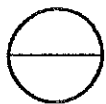

INDUSTRIAL GATE DETAIL

STYLE:

NOTES:

1. GATE FABRIC TO MATCH FENCE

RED DOT SHOP TI



MEMBER OF TROAX® GROUP

Providing Reliable Engineered Solutions

SAF-T-FENCE™ Machine Guarding

SAF-SPC94XX-M & SAF-SPC142XX-M

PARTS LIST:

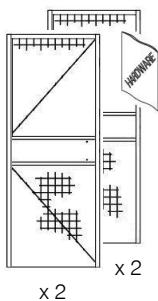

- SAF-T-FENCE DOOR PANEL (BLACK)
- SAF-T-FENCE DOOR EXTENSION PANEL WITH HARDWARE (BLACK)

x 2

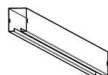

- SAF-T-FENCE SLIDE DOOR TRACK (BLACK)

x 2



- HARDWARE KIT (FOR SAF-T-FENCE CLEAR-ACCESS SLIDE PAIR DOORS SAF-SPC94XX-M & SAF-SPC142XX-M)

x 1

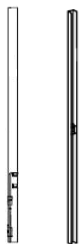

- SAF-T-FENCE CANE BOLT ASSEMBLY (BLACK)
- DOOR RECEIVER (BLACK)

x 1

x 1

NOTE:

REFER TO INSTRUCTION SHEET FGI-217 (INCLUDED IN KT6001) PRIOR TO BEGINNING THIS INSTALLATION.

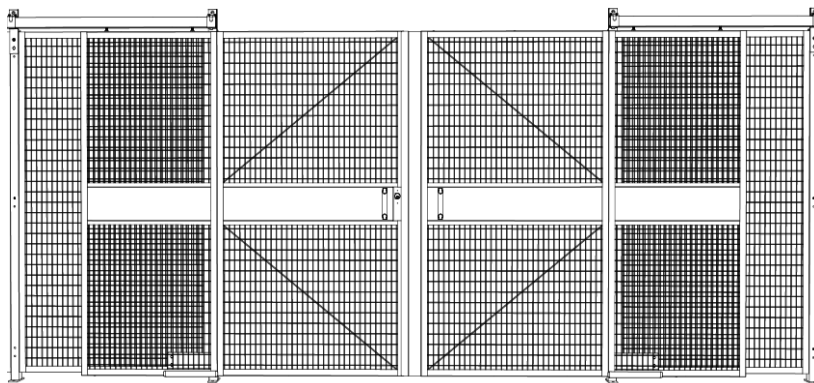

TOOLS REQUIRED:

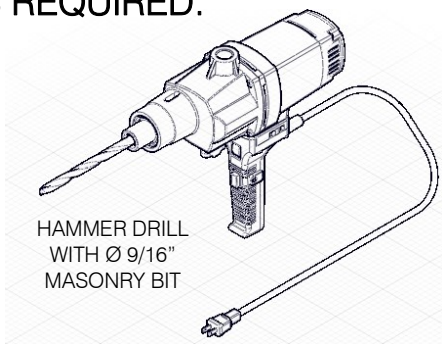

HAMMER DRILL WITH Ø 9/16" MASONRY BIT

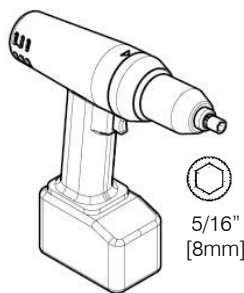

BATTERY DRILL

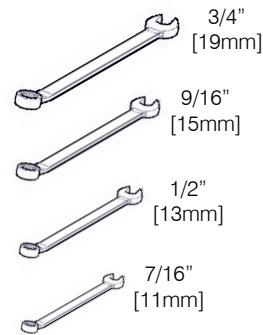

OPEN END WRENCH

HARDWARE PROVIDED: HARDWARE KIT #KT230 - For use on SAF-SPCXX82-M

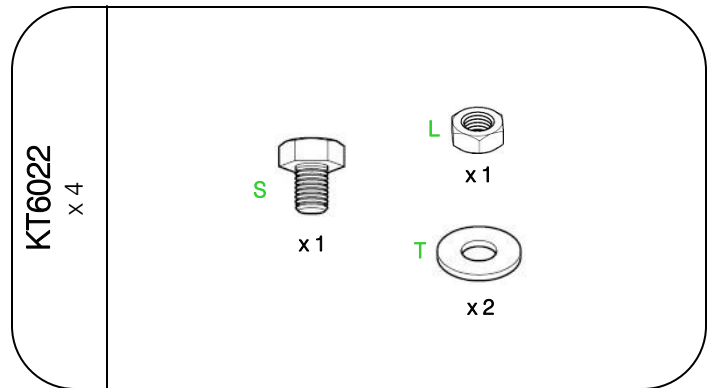
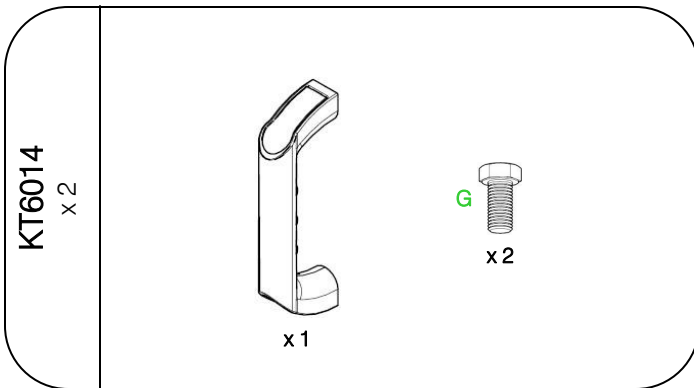
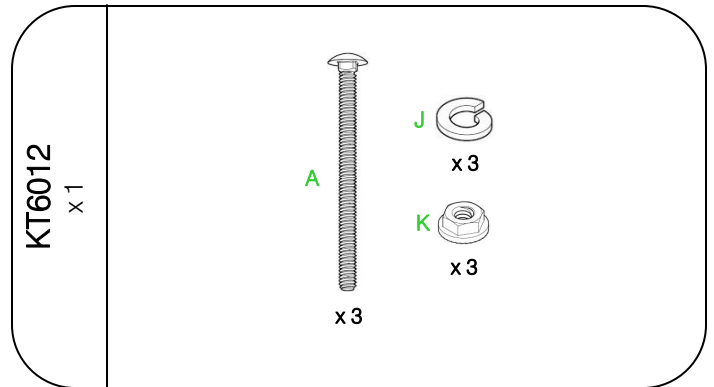
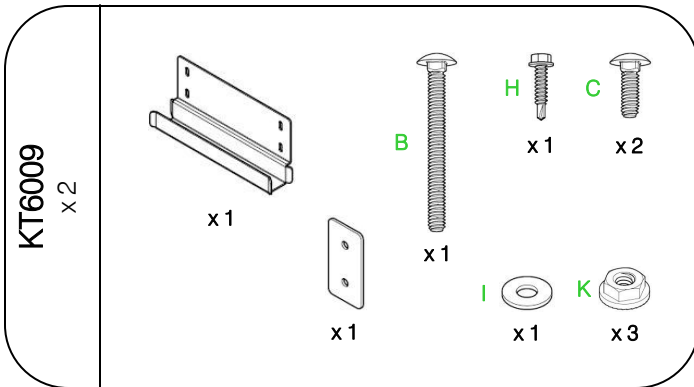
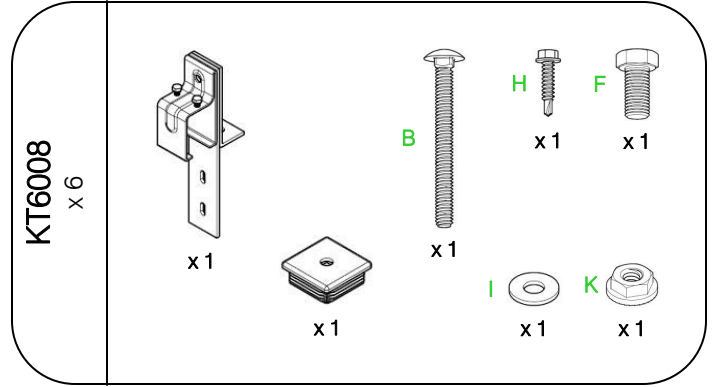
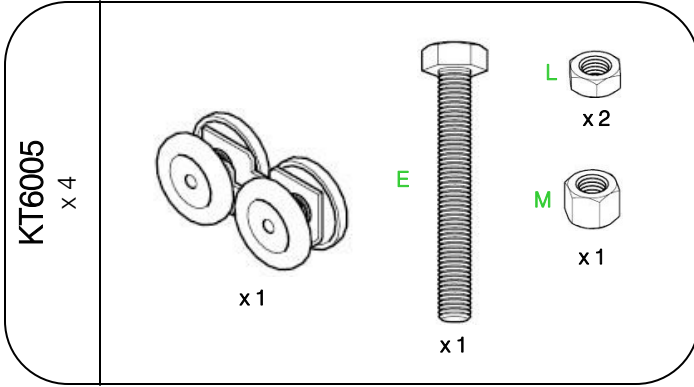

HARDWARE LIST:

- (A) 1/4"-20 x 3-1/2" SQUARE NECK CARRIAGE BOLT
- (B) 1/4"-20 x 2-1/2" SQUARE NECK CARRIAGE BOLT
- (C) 1/4"-20 x 1" SQUARE NECK CARRIAGE BOLT
- (D) 1/4"-20 x 1/2" SQUARE NECK CARRIAGE BOLT
- (E) 1/2"-13 x 4" HEX HEAD BOLT
- (F) 3/18"-16 x 1" HEX HEAD BOLT
- (G) M8-1.25 x 20 HEX HEAD BOLT
- (H) #12-14 x 1" HEX HEAD SELF-DRILLING SCREW
- (I) 1/4" FLAT WASHER
- (J) 1/4" LOCK WASHER
- (K) 1/4"-20 FLANGE NUT
- (L) 1/2"-13 HEX JAM NUT
- (M) 1/2"-13 NYLON LOCK NUT
- (S) 1/2"-13 x 1" HEX HEAD BOLT
- (T) 1/2" FLAT WASHER

HARDWARE PROVIDED: HARDWARE KIT #KT231 - For use on SAF-SPCXX94-M

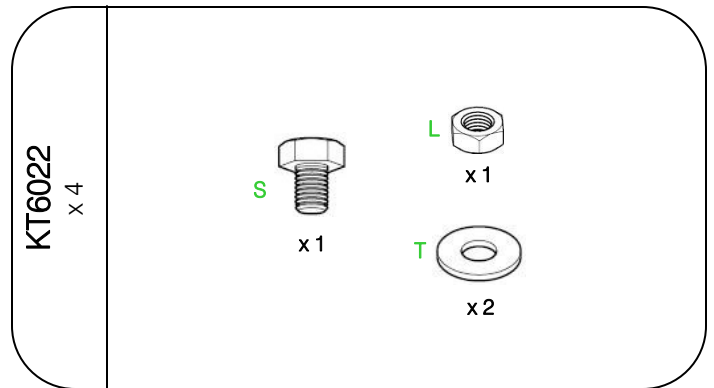
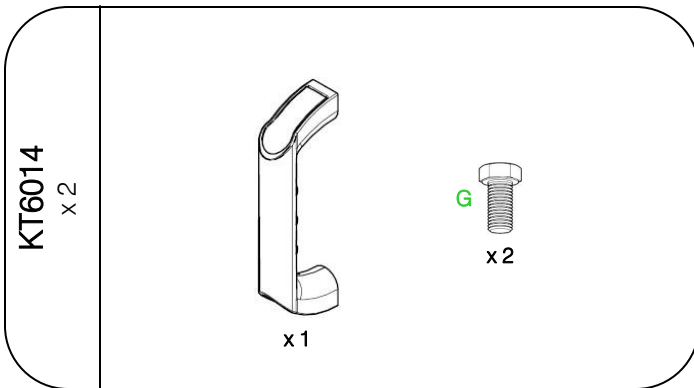
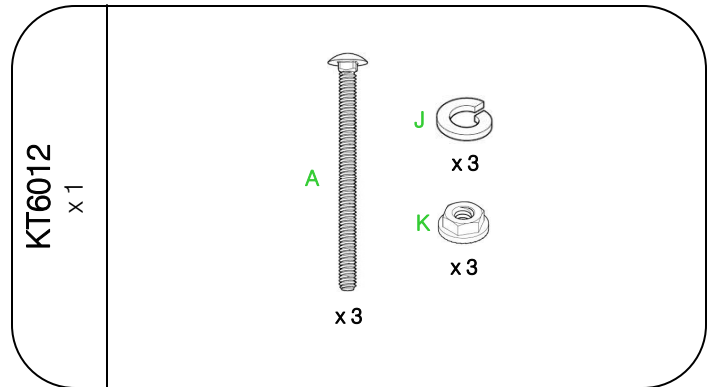
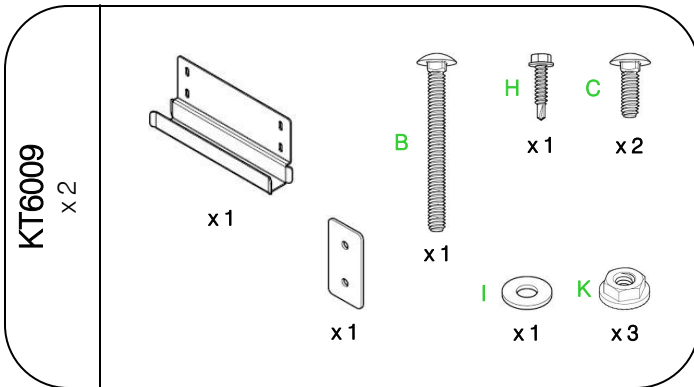
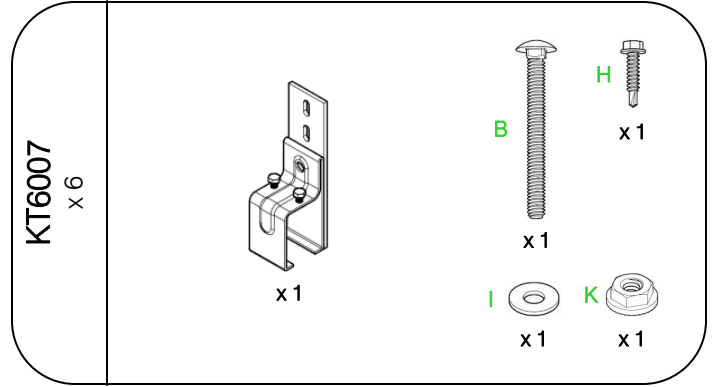
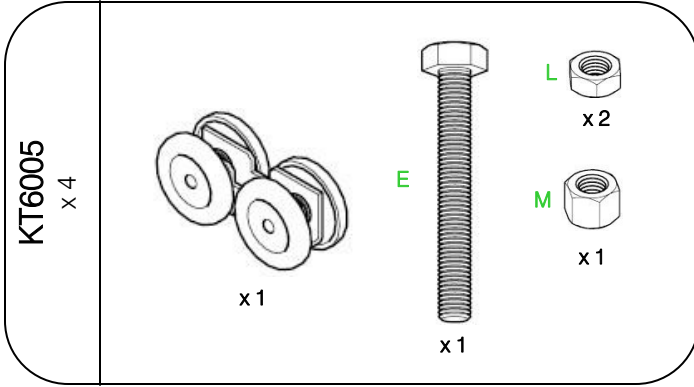

HARDWARE LIST:

- (A) 1/4"-20 x 3-1/2" SQUARE NECK CARRIAGE BOLT
- (B) 1/4"-20 x 2-1/2" SQUARE NECK CARRIAGE BOLT
- (C) 1/4"-20 x 1" SQUARE NECK CARRIAGE BOLT
- (D) 1/4"-20 x 1/2" SQUARE NECK CARRIAGE BOLT
- (E) 1/2"-13 x 4" HEX HEAD BOLT
- (F) 3/18"-16 x 1" HEX HEAD BOLT
- (G) M8-1.25 x 20 HEX HEAD BOLT
- (H) #12-14 x 1" HEX HEAD SELF-DRILLING SCREW
- (I) 1/4" FLAT WASHER
- (J) 1/4" LOCK WASHER
- (K) 1/4"-20 FLANGE NUT
- (L) 1/2"-13 HEX JAM NUT
- (M) 1/2"-13 NYLON LOCK NUT
- (S) 1/2"-13 x 1" HEX HEAD BOLT
- (T) 1/2" FLAT WASHER

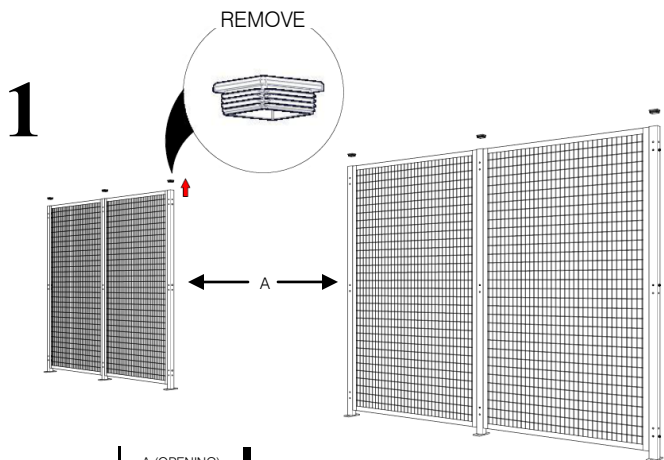

	A (OPENING)
SAF-SPC94XX-M	94" [2388mm]
SAF-SPC142XX-M	142" [3607mm]

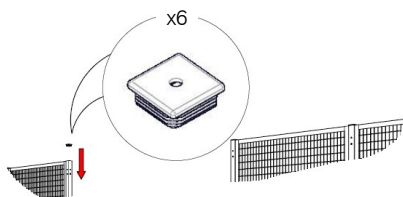

2a

(KT230)

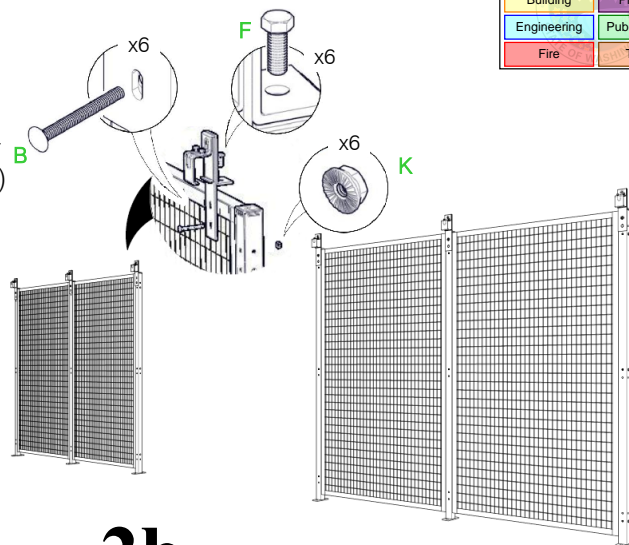

2b

(KT231)

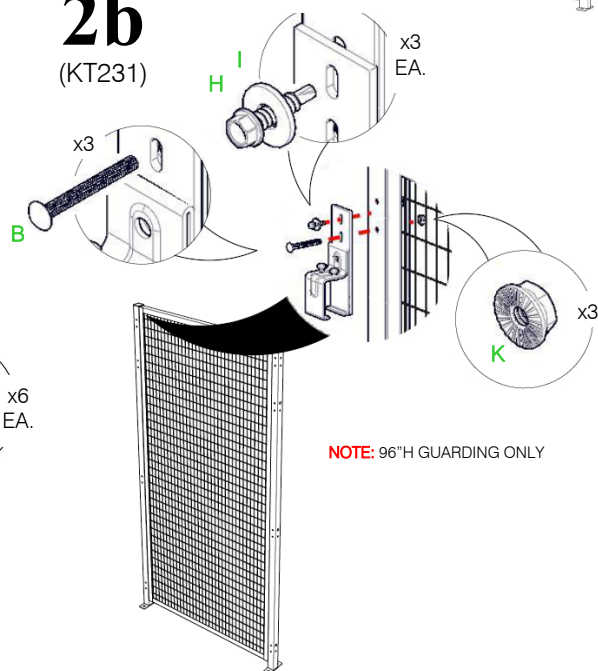

3

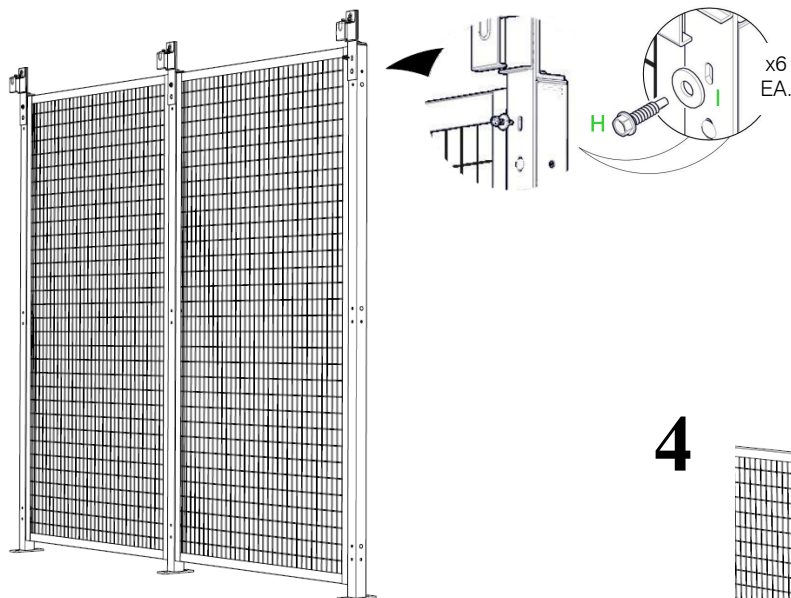

NOTE: BATTERY DRILL REQ'D FOR STEPS 3 & 4

4

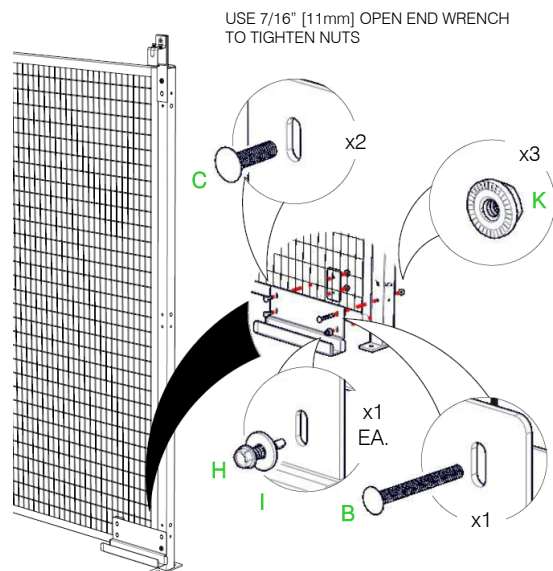

5

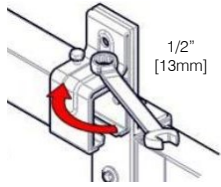

NOTE: **DO NOT** OVER TIGHTEN

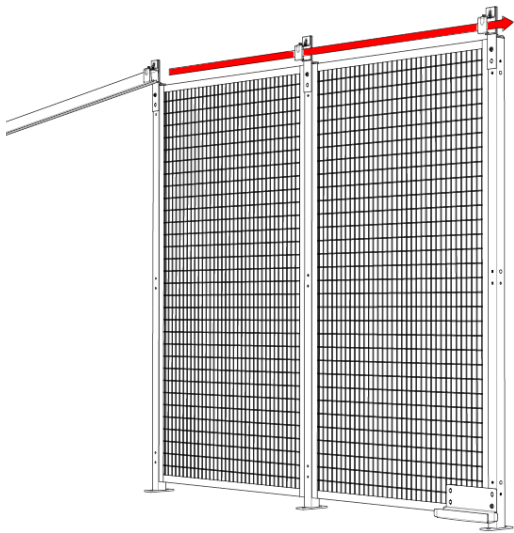

7

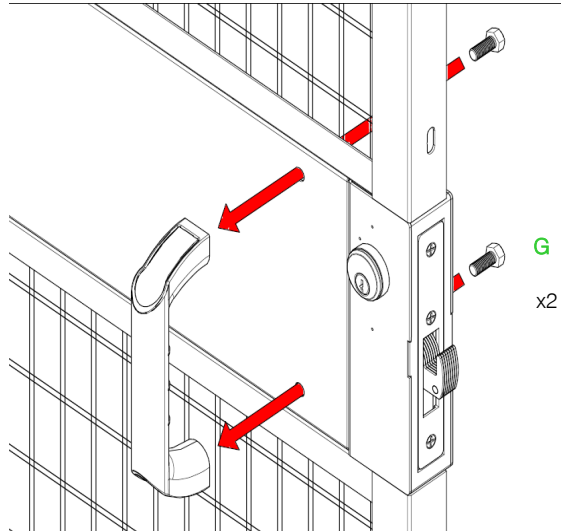

USE 9/16" [13mm] OPEN END WRENCH TO TIGHTEN BOLTS

6

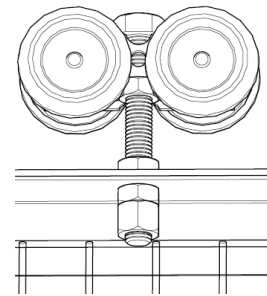
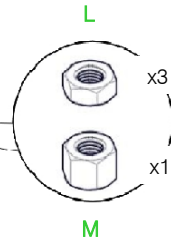
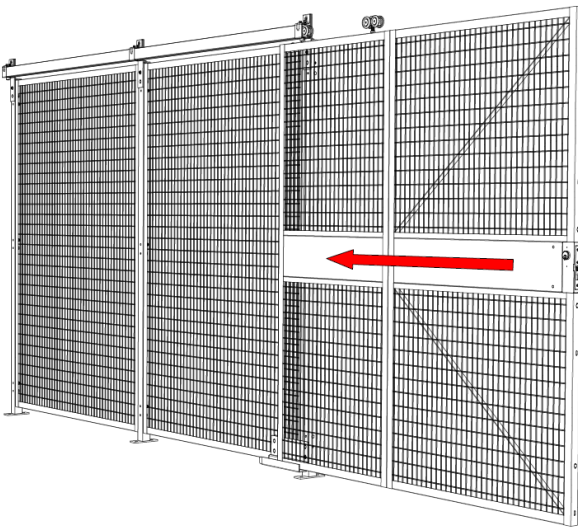
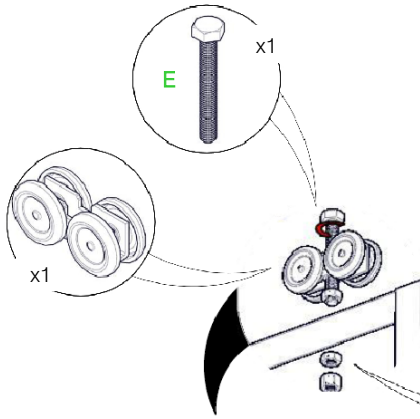

TROLLEY DETAIL

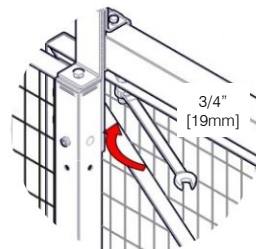

INSIDE

8

NOTE: REPEAT STEPS 4-8 FOR RIGHT-HAND DOOR

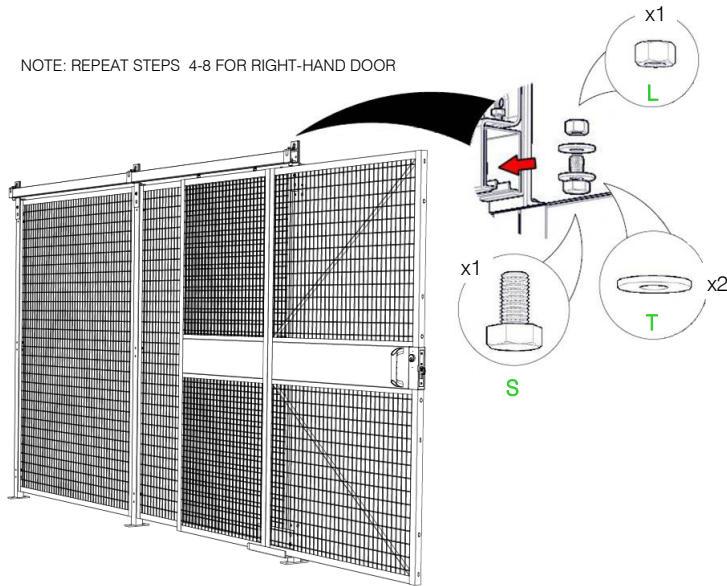

INSTALL DOOR STOPS IN REAR AND FRONT OF EACH DOOR

9

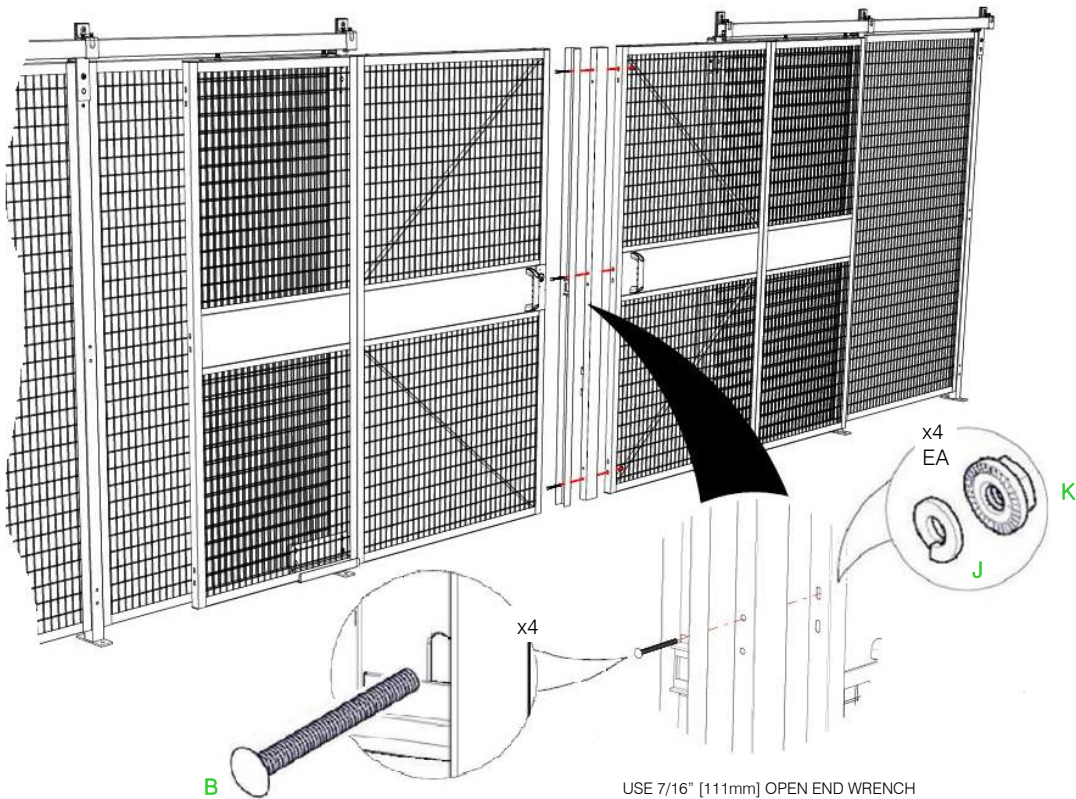

USE 7/16" [111mm] OPEN END WRENCH TO TIGHTEN NUTS

10

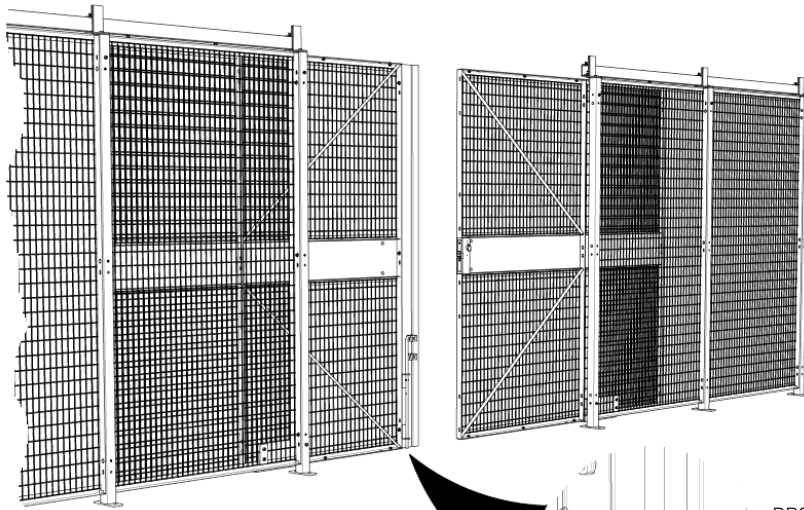

INSIDE

DROP CANE BOLT,
 MARK LOCATION

11

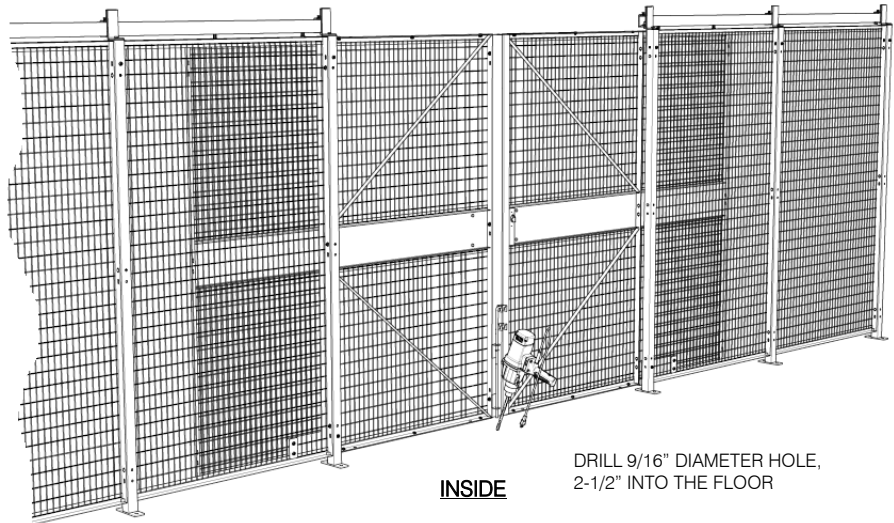

INSIDE

DRILL 9/16" DIAMETER HOLE,
 2-1/2" INTO THE FLOOR

Provide signage doors to remain open during business hours on all gates.

12

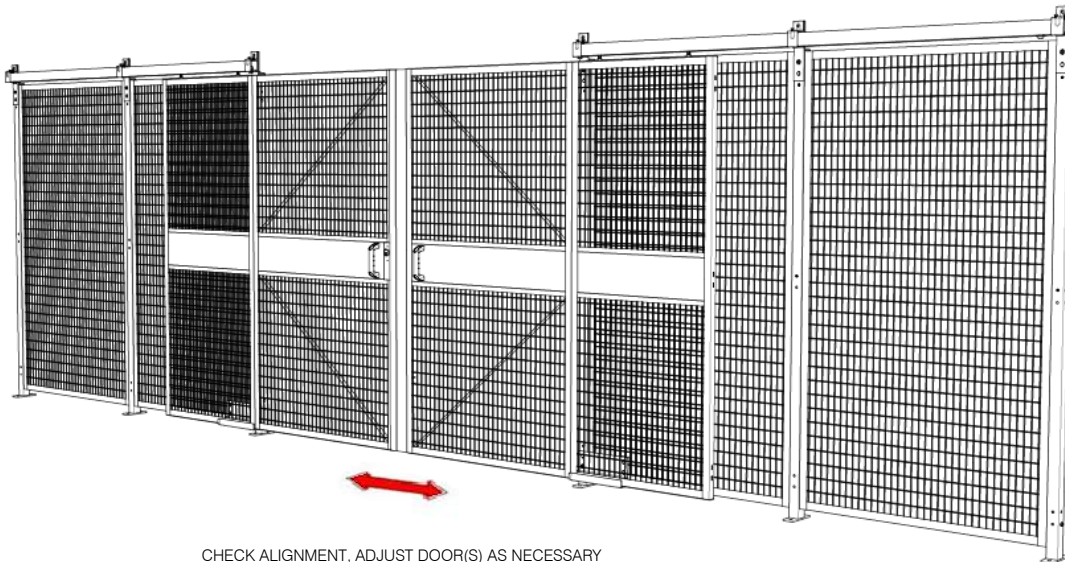

CHECK ALIGNMENT, ADJUST DOOR(S) AS NECESSARY