

RYKA CONSULTING

MOUNT ANALYSIS REPORT

THE APPROVED CONSTRUCTION PLANS, DOCUMENTS AND ALL ENGINEERING MUST BE POSTED ON THE JOB AT ALL INSPECTIONS IN A VISIBLE AND READILY ACCESSIBLE LOCATION.

FULL SIZED LEDGIBLE COLOR PLANS ARE REQUIRED TO BE PROVIDED BY THE PERMITEE ON SITE FOR INSPECTION

Prepared For:



AT&T Mobility
16221 NE 72nd Way
Redmond, WA 98052

Project Name:

Good Samaritan
WA6659

Project Address:

407 14th Avenue Southeast
Puyallup, WA 98371

Site Coordinates:

47.1795
-122.2906



Prepared By:

Ryan McDaniel, P.E.

April 7, 2023

PROJECT SCOPE:

AT&T Mobility proposes the following: Add (6) active radio antennas. New antennas to be installed on new T-arm mounts.

ANALYSIS:

The purpose of this analysis is to determine if the existing installation is adequately supported under the proposed loadings and provide any recommendations for modification in order to bring the support structure into compliance if needed. The installation has been analyzed in accordance with ASCE 7-16. The following parameters were used for lateral analysis:

Basic Wind Speed: 98
 Wind Exposure: B
 Topographic Factor, k_{zt} : 1.00

Risk Category: IV
 Seismic Design Category: D
 Mapped Parameter, S_s : 1.267
 Mapped Parameter, S_1 : 0.436

This Mount Analysis Report for the existing AT&T equipment is limited to the equipment mounting and support frames. This analysis is based on the specific assumptions and conditions as stated within the following report.

RESULTS:

Based on our review of the existing structure loadings, we have determined the following:

Design Element	Capacity	Status
Antenna Mount	67.2%	PASS

Equipment Support Rating: 67.2% PASS (with modification)

Please refer to Appendix A for structural calculations supporting the above results and conclusions sections below for additional comments.

CONTENTS:

- 1 - 5 Report
- A Appendix A (Calculations)
- B Appendix B (Referenced Documents)

1 Antenna Sector Equipment Inventory

Existing Equipment Configuration

Elev. (ft)	Equipment Model	Sector	Mount	Qty.	Carrier
79.00	EPBQ-654L8H8-L2	A	Antenna Mount	1	AT&T
79.00	EPBQ-654L8H8-L2	A	Antenna Mount	1	AT&T
79.00	RRH 4T4R B5 160W AHCA	A	Antenna Mount	1	AT&T
79.00	RRH4x25-WCS-4R	A	Antenna Mount	1	AT&T
79.00	RRH 4T4R B12/14 320W AHLBA	A	Antenna Mount	1	AT&T
79.00	RRH 4T4R B25/66 320W AHFIB	A	Antenna Mount	1	AT&T
79.00	DC2-48-60-0-9E	A	Antenna Mount	1	AT&T
79.00	DC2-48-60-0-9E	A	Antenna Mount	1	AT&T
79.00	DC2-48-60-0-9E	A	Antenna Mount	1	AT&T
79.00	FC12-PC6-10E	A	Antenna Mount	1	AT&T
79.00	FC12-PC6-10E	A	Antenna Mount	1	AT&T
79.00	FC12-PC6-10E	A	Antenna Mount	1	AT&T

Final Equipment Configuration

80.00	EPBQ-654L8H8-L2	A	Antenna Mount	1	AT&T
80.00	EPBQ-654L8H8-L2	A	Antenna Mount	1	AT&T
88.75	Nokia AEQK	A	Antenna Mount	1	AT&T
88.75	Nokia AEQU	A	Antenna Mount	1	AT&T
80.00	RRH 4T4R B5 160W AHCA	A	Antenna Mount	1	AT&T
80.00	RRH4x25-WCS-4R	A	Antenna Mount	1	AT&T
80.00	RRH 4T4R B12/14 320W AHLBA	A	Antenna Mount	1	AT&T
80.00	RRH 4T4R B25/66 320W AHFIB	A	Antenna Mount	1	AT&T
80.00	DC2-48-60-0-9E	A	Antenna Mount	1	AT&T
80.00	DC2-48-60-0-9E	A	Antenna Mount	1	AT&T
80.00	DC2-48-60-0-9E	A	Antenna Mount	1	AT&T
80.00	FC12-PC6-10E	A	Antenna Mount	1	AT&T
80.00	FC12-PC6-10E	A	Antenna Mount	1	AT&T
80.00	FC12-PC6-10E	A	Antenna Mount	1	AT&T

See the Architectural and Structural Drawings for configuration, location, and elevations. See the structural calculations for a detailed account of the equipment and the capacity of the support structure.

1 Antenna Sector Equipment Inventory

Existing Equipment Configuration

Elev. (ft)	Equipment Model	Sector	Mount	Qty.	Carrier
80.00	EPBQ-654L8H8-L2	B	Antenna Mount	1	AT&T
80.00	EPBQ-654L8H8-L2	B	Antenna Mount	1	AT&T
80.00	RRH 4T4R B5 160W AHCA	B	Antenna Mount	1	AT&T
80.00	RRH4x25-WCS-4R	B	Antenna Mount	1	AT&T
80.00	RRH 4T4R B12/14 320W AHLBA	B	Antenna Mount	1	AT&T
80.00	RRH 4T4R B25/66 320W AHFIB	B	Antenna Mount	1	AT&T
80.00	DC2-48-60-0-9E	B	Antenna Mount	1	AT&T
80.00	DC2-48-60-0-9E	B	Antenna Mount	1	AT&T
80.00	DC2-48-60-0-9E	B	Antenna Mount	1	AT&T

Final Equipment Configuration

80.00	EPBQ-654L8H8-L2	B	Antenna Mount	1	AT&T
80.00	EPBQ-654L8H8-L2	B	Antenna Mount	1	AT&T
88.75	Nokia AEQK	B	Antenna Mount	1	AT&T
88.75	Nokia AEQU	B	Antenna Mount	1	AT&T
80.00	RRH 4T4R B5 160W AHCA	B	Antenna Mount	1	AT&T
80.00	RRH4x25-WCS-4R	B	Antenna Mount	1	AT&T
80.00	RRH 4T4R B12/14 320W AHLBA	B	Antenna Mount	1	AT&T
80.00	RRH 4T4R B25/66 320W AHFIB	B	Antenna Mount	1	AT&T
80.00	DC2-48-60-0-9E	B	Antenna Mount	1	AT&T
80.00	DC2-48-60-0-9E	B	Antenna Mount	1	AT&T
80.00	DC2-48-60-0-9E	B	Antenna Mount	1	AT&T

See the Architectural and Structural Drawings for configuration, location, and elevations. See the structural calculations for a detailed account of the equipment and the capacity of the support structure.

1 Antenna Sector Equipment Inventory

Existing Equipment Configuration

Elev. (ft)	Equipment Model	Sector	Mount	Qty.	Carrier
79.00	EPBQ-654L8H8-L2	C	Antenna Mount	1	AT&T
79.00	EPBQ-654L8H8-L2	C	Antenna Mount	1	AT&T
79.00	RRH 4T4R B5 160W AHCA	C	Antenna Mount	1	AT&T
79.00	RRH4x25-WCS-4R	C	Antenna Mount	1	AT&T
79.00	RRH 4T4R B12/14 320W AHLBA	C	Antenna Mount	1	AT&T
79.00	RRH 4T4R B25/66 320W AHFIB	C	Antenna Mount	1	AT&T
79.00	DC2-48-60-0-9E	C	Antenna Mount	1	AT&T
79.00	DC2-48-60-0-9E	C	Antenna Mount	1	AT&T
79.00	DC2-48-60-0-9E	C	Antenna Mount	1	AT&T

Final Equipment Configuration

80.00	EPBQ-654L8H8-L2	C	Antenna Mount	1	AT&T
80.00	EPBQ-654L8H8-L2	C	Antenna Mount	1	AT&T
88.75	Nokia AEQK	C	Antenna Mount	1	AT&T
88.75	Nokia AEQU	C	Antenna Mount	1	AT&T
80.00	RRH 4T4R B5 160W AHCA	C	Antenna Mount	1	AT&T
80.00	RRH4x25-WCS-4R	C	Antenna Mount	1	AT&T
80.00	RRH 4T4R B12/14 320W AHLBA	C	Antenna Mount	1	AT&T
80.00	RRH 4T4R B25/66 320W AHFIB	C	Antenna Mount	1	AT&T
80.00	DC2-48-60-0-9E	C	Antenna Mount	1	AT&T
80.00	DC2-48-60-0-9E	C	Antenna Mount	1	AT&T
80.00	DC2-48-60-0-9E	C	Antenna Mount	1	AT&T

See the Architectural and Structural Drawings for configuration, location, and elevations. See the structural calculations for a detailed account of the equipment and the capacity of the support structure.

2 Reference Documents

The following data was used to model and analyze the structure.

Date	Document	Author
	2018 IBC	International Code Council
	ASCE 7-16	ASCE
12/14/2022	RFDS	AT&T
09-12-11	Construction Drawings	Cornerstone Engineering
May 12, 2015	Structural Calculations	Cornerstone Engineering

3 Design Comments

Telecommunication equipment is being reconfigured on an existing building. New active radio antennas will be mounted on new T-arm mounts at existing mount locations.

Load combinations are applied per ASCE 7-16 Sections 2.4.1. Combinations involving reduced dead loads, live loads, and seismic loads are eliminated because they do not apply, or by inspection. The following load combinations remain:

1. D
2. D + L
3. D + S
5. D + 0.6W

The new antenna mount is checked for the new antenna loads.

The new mounts and building support are analyzed for the scope of this report. The telecommunications equipment does not add an additional 5% weight or 10% lateral load to the existing building and does not require retrofit. Local elements are checked.

1 Conclusion / Recommendations

To the best of our knowledge and belief, the modified shroud anchorage and pipe mount will be in compliance with the requirements of the specifications codes and agencies having jurisdiction over the work.

2 Scope and Liability

1. This report is prepared with the information furnished to Ryka by our client. If the conditions of the site change, or if new information becomes available, the results of this report are not valid. Ryka should be notified so that the report can be updated and resubmitted.
2. This report is meant to show the level of conformance for the site with the referenced codes. No other assessment is implied.
3. Ryka has not performed invasive testing or inspection which might reveal corrosion, damage, or work not installed per plan. The contractor should report any of these occurrences upon discovery.
4. The contractor hired for construction of items included in this report are responsible for verifying that work described in previous plan sheets has been installed per plan.
5. Ryka has not engineered, tested, or inspected the manufacture of third party vendor items such as mounts, poles, and other support structures. We select equipment from vendors which provide their own engineering and quality control. Ryka cannot be responsible for defective hardware or supports which do not meet the published support capacity.
6. Ryka is not responsible for the conclusions, opinions and recommendations made by others based on the information contained herein.
7. It is assumed that the existing mounting structure is in good condition with no damage that could cause a reduced capacity.

A Appendix – Structural Calculations

SITE PARAMETERS:

Risk Category = IV (Table 1-1) Latitude = 47.1795 (USGS)
 Site Soil Classification = D (Table 20.3-1) Longitude = -122.2906 (USGS)

MAPPED ACCELERATION PARAMETERS:

Mapped Parameter, S_s = 1.267 (USGS)
 Mapped Parameter, S_1 = 0.436 (USGS)

MAPPED SPECTRAL RESPONSE ACCELERATION PARAMETERS:

Site Coefficient, F_a = 1.20g (Table 11.4-1)
 Site Coefficient, F_v = 1.864g (Table 11.4-2)
 $S_{MS} = F_a S_s = 1.52g$ (Eq 11.4-4)
 $S_{M1} = F_v S_1 = 0.813g$ (Eq 11.4-1)

DESIGN SPECTRAL RESPONSE PARAMETERS:

$S_{DS} = \frac{2}{3} S_{MS} = 1.014g$ (Eq 11.4-3)
 $S_{D1} = \frac{2}{3} S_{M1} = 0.542g$ (Eq 11.4-4)

SEISMIC DESIGN CATEGORY

Seismic Design Category = D (Tables 11.6-1 and 11.6-2)

SEISMIC DESIGN FORCE FOR NONSTRUCTURAL COMPONENTS:

Average Structure Height, h = 64.67 ft
 Height of Component, z = 88.75 ft

Importance Factor, I_e = 1.50 (Sec 13.1-3)
 Response Mod. Factor, R_p = 2.5 (Table 13.5-1 or 13.6-1)
 Amplification Factor, a_p = 1.0 (Table 13.6-1)
 $F_{p,max} = 2.433$ (Eqn 13.3-2)
 $F_{p,min} = 0.456$ (Eqn 13.3-3)
 Seismic Design Force, F_p = 0.730 (Eqn 13.3-1)

Seismic Design Force, F_p = 0.730 (Eq 12.8-1)

Seismic Design Force, F_p = 0.511 (ASD)

DESCRIPTION: ASCE 7-16 Wind Factors

Risk Category =	IV		(Table 1.5-1)
Wind Speed, V =	98	mph	(Figure 26.5-1)
Directionality Factor, K_d =	0.90		(Table 26.6-1)
Exposure Category =	B		(Section 26.7)
Topographic Factor, K_{zt} =	1.00		(Section 26.8 & Figure 26.8-1)
Ground Elevation Factor, K_e =	0.997		(Section 26.9 and Table 26.9-1)
Gust Factor, G =	0.85		(Section 26.11.1)
Avg Height of Equipment, z =	88.8	ft	
Velocity Pressure Coeff., K_h =	0.96		(Table 27.3-1)
velocity pressure, $q_h = 0.00256 K_h K_{zt} K_d K_e V^2$			(Eq 26.10-1)
velocity pressure, $q_h = 21.1$			psf (Section 27.4.7 indicates 16 psf min. pressure)

DESIGN WIND LOADS: OTHER STRUCTURES

Design Lateral Wind Pressure, $P_h =$	17.9	psf	(From Eq. 29.4-2, where $F = P C_f A_r$)
Design Lateral Wind Pressure, $P_h =$	10.8	psf	(ASD)

Velocity Pressure, $q_z = 21.1$ psf
 $G = 0.85$

Item	Flat / Round	Dish / Panel	Height in	Width in	Depth in	Cf(n)			Cf(t)		
						1	7	25	1	7	25
EPBQ-654L8H8-L2	F	P	96.00	21.00	6.30	1.3	1.4	2	1.3	1.4	2
RRH 4T4R B5 160W AHCA	F	P	13.37	11.61	6.50	1.3	1.4	2	1.3	1.4	2
RRH4x25-WCS-4R	F	P	31.50	12.00	8.70	1.3	1.4	2	1.3	1.4	2
RRH 4T4R B12/14 320W AHLBA	F	P	15.70	11.80	4.70	1.3	1.4	2	1.3	1.4	2
RRH 4T4R B25/66 320W AHFIB	F	P	28.70	15.40	9.40	1.3	1.4	2	1.3	1.4	2
DC2-48-60-0-9E	F	P	10.25	10.40	6.30	1.3	1.4	2	1.3	1.4	2
FC12-PC6-10E	F	P	14.75	16.10	6.59	1.3	1.4	2	1.3	1.4	2
Nokia AEQK	F	P	29.50	17.70	9.50	1.3	1.4	2	1.3	1.4	2
Nokia AEQU	F	P	29.50	17.70	9.50	1.3	1.4	2	1.3	1.4	2
2"x 120" S40 Stl Pipe	R	P	120.00	2.38	2.38	0.7	0.8	1.2	0.7	0.8	1.2
2"x 42" S40 Stl Pipe	R	P	42.00	2.38	2.38	0.7	0.8	1.2	0.7	0.8	1.2
2"x 30" S40 Stl Pipe	R	P	30.00	2.38	2.38	0.7	0.8	1.2	0.7	0.8	1.2
Emerson 5100	F	P	72.00	32.00	39.00	1.3	1.4	2	1.3	1.4	2
Emerson Netsure Battery Cabinet	F	P	72.06	36.02	36.79	1.3	1.4	2	1.3	1.4	2

Item	Height in	Width in	Depth in	Aspect (norm)	Aspect (tan)	Cf (norm)	Cf (tan)	Af (norm)	Af (tan)
EPBQ-654L8H8-L2	96.00	21.00	6.30	4.57	15.24	1.36	1.67	14.00	4.20
RRH 4T4R B5 160W AHCA	13.37	11.61	6.50	1.15	2.06	1.30	1.32	1.08	0.60
RRH4x25-WCS-4R	31.50	12.00	8.70	2.63	3.62	1.33	1.34	2.63	1.90
RRH 4T4R B12/14 320W AHLBA	15.70	11.80	4.70	1.33	3.34	1.31	1.34	1.29	0.51
RRH 4T4R B25/66 320W AHFIB	28.70	15.40	9.40	1.86	3.05	1.31	1.33	3.07	1.87
DC2-48-60-0-9E	10.25	10.40	6.30	0.99	1.63	1.30	1.31	0.74	0.45
FC12-PC6-10E	14.75	16.10	6.59	0.92	2.24	1.30	1.32	1.65	0.68
Nokia AEQK	29.50	17.70	9.50	1.67	3.11	1.31	1.34	3.63	1.95
Nokia AEQU	29.50	17.70	9.50	1.67	3.11	1.31	1.34	3.63	1.95
2"x 120" S40 Stl Pipe	120.00	2.38	2.38	50.42	50.42	1.20	1.20	1.98	1.98
2"x 42" S40 Stl Pipe	42.00	2.38	2.38	17.65	17.65	1.04	1.04	0.69	0.69
2"x 30" S40 Stl Pipe	30.00	2.38	2.38	12.61	12.61	0.92	0.92	0.50	0.50
Emerson 5100	72.00	32.00	39.00	2.25	1.85	1.32	1.31	16.00	19.50
Emerson Netsure Battery Cabinet	72.06	36.02	36.79	2.00	1.96	1.32	1.32	18.03	18.41

$F_p = 0.511$ W
 $S_{Ds} = 1.014$ g
 Design Lateral Wind Pressure, $P_h = 10.8$ psf

Applied Forces (lbs)

Item	Weight	E _h	E _v	F _{no}	F _{to}				
EPBQ-654L8H8-L2	86.0	43.9	17.4	204.7	75.7				
RRH 4T4R B5 160W AHCA	36.8	18.8	7.5	15.1	8.6				
RRH4x25-WCS-4R	70.0	35.8	14.2	37.5	27.5				
RRH 4T4R B12/14 320W AHLBA	32.6	16.7	6.6	18.1	7.4				
RRH 4T4R B25/66 320W AHFIB	88.2	45.1	17.9	43.4	26.9				
DC2-48-60-0-9E	16.0	8.2	3.2	10.4	6.3				
FC12-PC6-10E	35.0	17.9	7.1	23.1	9.6				
Nokia AEQK	99.2	50.7	20.1	51.1	27.9				
Nokia AEQU	99.2	50.7	20.1	51.1	27.9				
2"x 120" S40 Stl Pipe	36.5	18.6	7.4	25.6	25.6				
2"x 42" S40 Stl Pipe	12.8	6.5	2.6	7.7	7.7				
2"x 30" S40 Stl Pipe	9.1	4.7	1.8	4.9	4.9				
Emerson 5100	2,300.0	1175.0	466.3	227.3	275.6				
Emerson Netsure Battery Cabinet	4,010.0	2048.5	812.9	255.3	260.6				

Existing Sector A Equipment (lbs)				Existing Sector B Equipment (lbs)			
Item	Weight	F _{no}	F _{to}	Item	Weight	F _{no}	F _{to}
EPBQ-654L8H8-L2	86.0	204.7	75.7	EPBQ-654L8H8-L2	86.0	204.7	75.7
EPBQ-654L8H8-L2	86.0	204.7	75.7	EPBQ-654L8H8-L2	86.0	204.7	75.7
RRH 4T4R B5 160W AHCA	36.8	15.1	8.6	RRH 4T4R B5 160W AHCA	36.8	15.1	8.6
RRH4x25-WCS-4R	70.0	37.5	27.5	RRH4x25-WCS-4R	70.0	37.5	27.5
RRH 4T4R B12/14 320W AHLBA	32.6	18.1	7.4	RRH 4T4R B12/14 320W AHLBA	32.6	18.1	7.4
RRH 4T4R B25/66 320W AHFIB	88.2	43.4	26.9	RRH 4T4R B25/66 320W AHFIB	88.2	43.4	26.9
DC2-48-60-0-9E	16.0	10.4	6.3	DC2-48-60-0-9E	16.0	10.4	6.3
DC2-48-60-0-9E	16.0	10.4	6.3	DC2-48-60-0-9E	16.0	10.4	6.3
DC2-48-60-0-9E	16.0	10.4	6.3	DC2-48-60-0-9E	16.0	10.4	6.3
FC12-PC6-10E	35.0	23.1	9.6				
FC12-PC6-10E	35.0	23.1	9.6				
FC12-PC6-10E	35.0	23.1	9.6				
Sector Total	346			Sector Total	311		

Proposed Sector A Equipment (lbs)				Proposed Sector B Equipment (lbs)			
Item	Weight	F _{no}	F _{to}	Item	Weight	F _{no}	F _{to}
EPBQ-654L8H8-L2	86.0	204.7	75.7	EPBQ-654L8H8-L2	86.0	204.7	75.7
EPBQ-654L8H8-L2	86.0	204.7	75.7	EPBQ-654L8H8-L2	86.0	204.7	75.7
Nokia AEQK	99.2	51.1	27.9	Nokia AEQK	99.2	51.1	27.9
Nokia AEQU	99.2	51.1	27.9	Nokia AEQU	99.2	51.1	27.9
RRH 4T4R B5 160W AHCA	36.8	15.1	8.6	RRH 4T4R B5 160W AHCA	36.8	15.1	8.6
RRH4x25-WCS-4R	70.0	37.5	27.5	RRH4x25-WCS-4R	70.0	37.5	27.5
RRH 4T4R B12/14 320W AHLBA	32.6	18.1	7.4	RRH 4T4R B12/14 320W AHLBA	32.6	18.1	7.4
RRH 4T4R B25/66 320W AHFIB	88.2	43.4	26.9	RRH 4T4R B25/66 320W AHFIB	88.2	43.4	26.9
DC2-48-60-0-9E	16.0	10.4	6.3	DC2-48-60-0-9E	16.0	10.4	6.3
DC2-48-60-0-9E	16.0	10.4	6.3	DC2-48-60-0-9E	16.0	10.4	6.3
DC2-48-60-0-9E	16.0	10.4	6.3	DC2-48-60-0-9E	16.0	10.4	6.3
FC12-PC6-10E	35.0	23.1	9.6				
FC12-PC6-10E	35.0	23.1	9.6				
FC12-PC6-10E	35.0	23.1	9.6				
Sector Total	751			Sector Total	646		

Existing Sector C Equipment (lbs)				Existing Sector D Equipment (lbs)			
Item	Weight	F _{no}	F _{to}	Item	Weight	F _{no}	F _{to}
EPBQ-654L8H8-L2	86.0	204.7	75.7				
EPBQ-654L8H8-L2	86.0	204.7	75.7				
RRH 4T4R B5 160W AHCA	36.8	15.1	8.6				
RRH4x25-WCS-4R	70.0	37.5	27.5				
RRH 4T4R B12/14 320W AHLBA	32.6	18.1	7.4				
RRH 4T4R B25/66 320W AHFIB	88.2	43.4	26.9				
DC2-48-60-0-9E	16.0	10.4	6.3				
DC2-48-60-0-9E	16.0	10.4	6.3				
DC2-48-60-0-9E	16.0	10.4	6.3				
Sector Total	448						

Proposed Sector C Equipment (lbs)				Proposed Sector D Equipment (lbs)			
Item	Weight	F _{no}	F _{to}	Item	Weight	F _{no}	F _{to}
EPBQ-654L8H8-L2	86.0	204.7	75.7				
EPBQ-654L8H8-L2	86.0	204.7	75.7				
Nokia AEQK	99.2	51.1	27.9				
Nokia AEQU	99.2	51.1	27.9				
RRH 4T4R B5 160W AHCA	36.8	15.1	8.6				
RRH4x25-WCS-4R	70.0	37.5	27.5				
RRH 4T4R B12/14 320W AHLBA	32.6	18.1	7.4				
RRH 4T4R B25/66 320W AHFIB	88.2	43.4	26.9				
DC2-48-60-0-9E	16.0	10.4	6.3				
DC2-48-60-0-9E	16.0	10.4	6.3				
DC2-48-60-0-9E	16.0	10.4	6.3				
Sector Total	646			Sector Total			

Applied Forces (lbs)									
Item	Weight	Eh	Ev	F _{no}	F _{to}				
Antenna Mount									
Nokia AEQK	99	50.7	20.1	51.1	27.9				
Nokia AEQU	99	50.7	20.1	51.1	27.9				
2"x 42" S40 Stl Pipe	13	6.5	2.6	7.7	7.7				
2"x 42" S40 Stl Pipe	13	6.5	2.6	7.7	7.7				
2"x 30" S40 Stl Pipe	9	4.7	1.8	4.9	4.9				
Total	233	119	47	123	76				
New Cabinets									
Emerson 5100	2,300	1,175	466	227	276				
Emerson Netsure Battery Cabinet	4,010	2,049	813	255	261				
Total	6,310	3,223	1,279	483	536	(least of all previous configs)			

DESCRIPTION: Antenna Mast

BEAM AND LOADING ATTRIBUTES:

Beam Segments	
x End	EI
0	11,177
9.5	11,177
0	0
0	0

Supports
x
0.5
3
0
0
0

Point Loads		
x	lbs	Moment
8.0	-122.69	0
0.0	0	0
0	0	0
0	0	0
0	0	0

Distributed Loads			
x Start	x End	lbs	lbs
0.00	9.50	-2.21	-2.21
0.00	0.00	0.00	0.00
0.00	0.00	0.00	0.00
0.00	0.00	0.00	0.00
0.00	0.00	0.00	0.00
0.00	0.00	0.00	0.00
0.00	0.00	0.00	0.00
0.00	0.00	0.00	0.00
0.00	0.00	0.00	0.00

Loads (lbs)

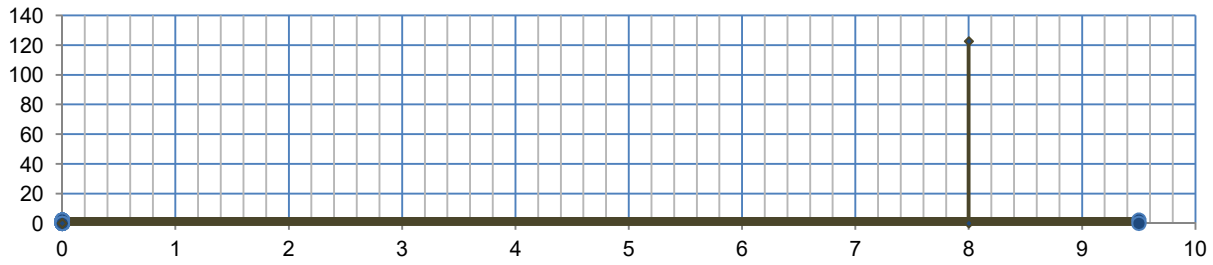

Shear Force (lbs)

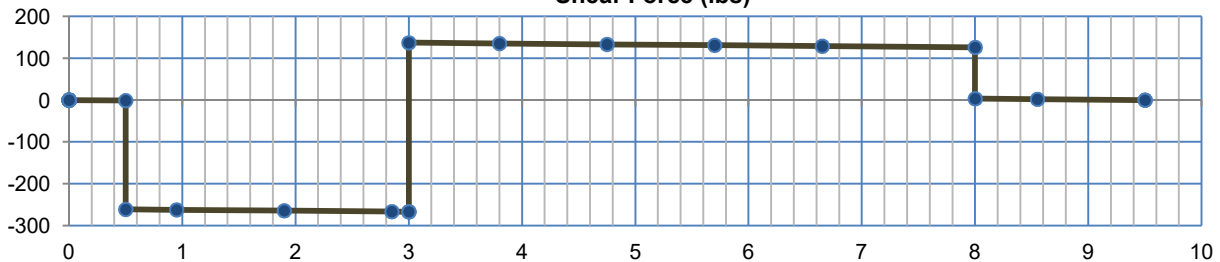

Max. = 267 lbs

Bending Moment (ft-lbs)

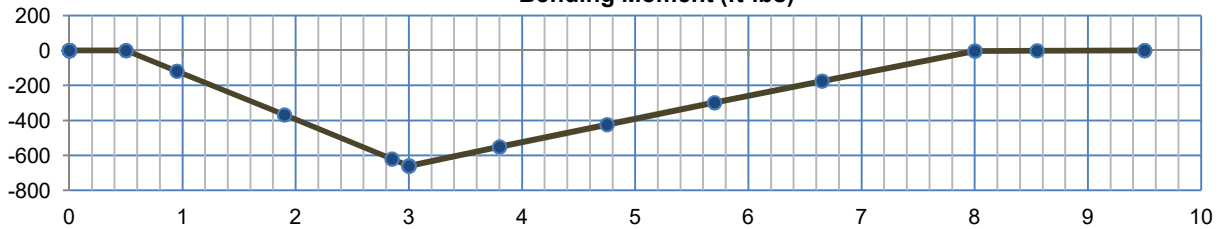

Max. = 660 ft-lbs

Deflection (in.)

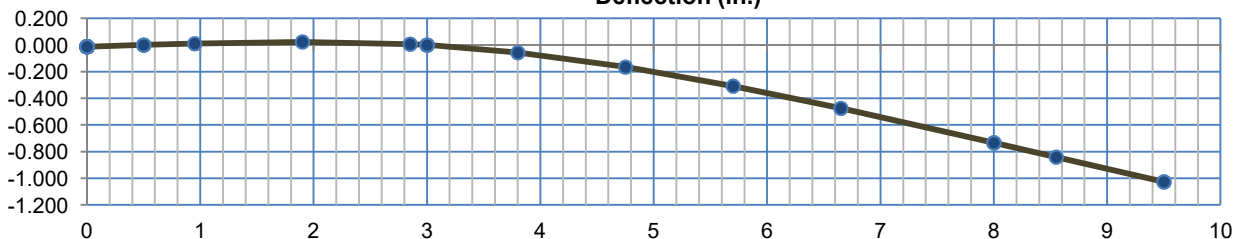

Max. = 1.0265 in.

DESCRIPTION: Antenna Mast	
BEAM PROPERTIES: Beam shape = P 2" Sch 40	
A = 1.070 in ²	S _x = 0.561 in ³
Weight = 3.650 plf	S _y = 0.561 in ³
O.D. = 2.375 in	I _x = 0.666 in ⁴
	I _y = 0.666 in ⁴
MATERIAL PROPERTIES:	r _x = 0.787 in.
E = 29,000 ksi	r _y = 0.787 in.
F _y = 35,000 psi	
BEAM LOADING:	
Unsupported Length, L = 114 in.	
Moment, M = 0.660 kip-ft = 7,922 in-lbs	
Shear, V = 0.267 kips	
Deflection, Δ = 1.027 in.	
Span Length / Deflection = 111	
BEAM STRESS:	
Bending stress, f _{bx} = 14,121 psi	
Allowable Bending, F _{bx} = 0.6 F _y = 21,000 psi	
Required S _x = 0.4 in ³	O.K.
Shear Stress f _v = 249 psi	
Allowable Shear Stress = 0.4 F _y = 14,000 psi	O.K.
Required Area, A = 0.001 in ²	
SUMMARY: The calculated shear at the pipe supports is also the load to the mast anchorage. The load is small compared to the capacity of a 1/2" diameter A307 bolt.	
Utilization = 67.24%	of capacity

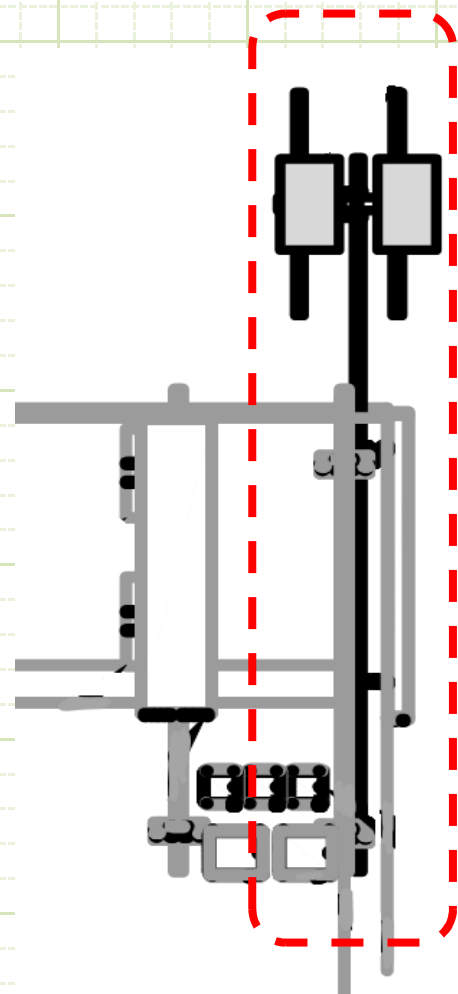

B Appendix – Referenced Documents



ASCE 7 Hazards Report

Address:
 407 14th Ave SE
 Puyallup, Washington
 98372

Standard: ASCE/SEI 7-16
Risk Category: II
Soil Class: D - Default (see Section 11.4.3)

Latitude: 47.179251
Longitude: -122.289637
Elevation: 122.28247765975831 ft (NAVD 88)

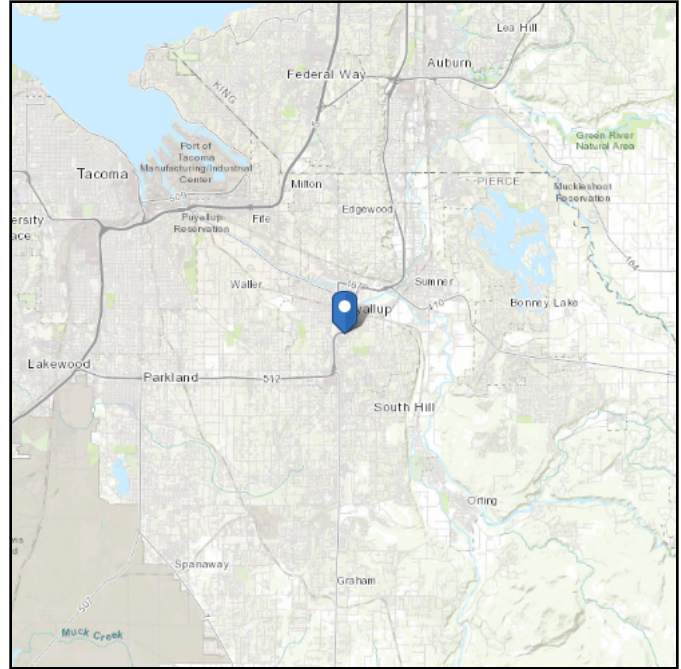
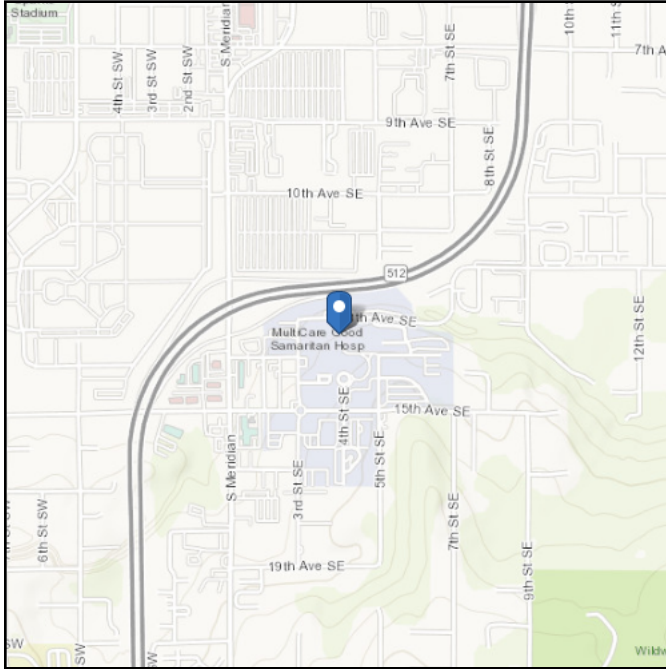

Wind

Results:

Wind Speed	98 Vmph
10-year MRI	67 Vmph
25-year MRI	73 Vmph
50-year MRI	78 Vmph
100-year MRI	83 Vmph

Data Source: ASCE/SEI 7-16, Fig. 26.5-1B and Figs. CC.2-1–CC.2-4, and Section 26.5.2
 Date Accessed: Sun Apr 02 2023

Value provided is 3-second gust wind speeds at 33 ft above ground for Exposure C Category, based on linear interpolation between contours. Wind speeds are interpolated in accordance with the 7-16 Standard. Wind speeds correspond to approximately a 7% probability of exceedance in 50 years (annual exceedance probability = 0.00143, MRI = 700 years).

Site is not in a hurricane-prone region as defined in ASCE/SEI 7-16 Section 26.2.



Seismic

Site Soil Class: D - Default (see Section 11.4.3)

Results:

S_s :	1.267	S_{D1} :	N/A
S_1 :	0.436	T_L :	6
F_a :	1.2	PGA :	0.5
F_v :	N/A	PGA _M :	0.6
S_{MS} :	1.52	F_{PGA} :	1.2
S_{M1} :	N/A	I_e :	1
S_{DS} :	1.013	C_v :	1.353

Ground motion hazard analysis may be required. See ASCE/SEI 7-16 Section 11.4.8.

Data Accessed: Sun Apr 02 2023

Date Source: [USGS Seismic Design Maps](#)



Ice

Results:

Ice Thickness:	1.00 in.
Concurrent Temperature:	25 F
Gust Speed	30 mph

Data Source: Standard ASCE/SEI 7-16, Figs. 10-2 through 10-8

Date Accessed: Sun Apr 02 2023

Ice thicknesses on structures in exposed locations at elevations higher than the surrounding terrain and in valleys and gorges may exceed the mapped values.

Values provided are equivalent radial ice thicknesses due to freezing rain with concurrent 3-second gust speeds, for a 500-year mean recurrence interval, and temperatures concurrent with ice thicknesses due to freezing rain. Thicknesses for ice accretions caused by other sources shall be obtained from local meteorological studies. Ice thicknesses in exposed locations at elevations higher than the surrounding terrain and in valleys and gorges may exceed the mapped values.

The ASCE 7 Hazard Tool is provided for your convenience, for informational purposes only, and is provided "as is" and without warranties of any kind. The location data included herein has been obtained from information developed, produced, and maintained by third party providers; or has been extrapolated from maps incorporated in the ASCE 7 standard. While ASCE has made every effort to use data obtained from reliable sources or methodologies, ASCE does not make any representations or warranties as to the accuracy, completeness, reliability, currency, or quality of any data provided herein. Any third-party links provided by this Tool should not be construed as an endorsement, affiliation, relationship, or sponsorship of such third-party content by or from ASCE.

ASCE does not intend, nor should anyone interpret, the results provided by this Tool to replace the sound judgment of a competent professional, having knowledge and experience in the appropriate field(s) of practice, nor to substitute for the standard of care required of such professionals in interpreting and applying the contents of this Tool or the ASCE 7 standard.

In using this Tool, you expressly assume all risks associated with your use. Under no circumstances shall ASCE or its officers, directors, employees, members, affiliates, or agents be liable to you or any other person for any direct, indirect, special, incidental, or consequential damages arising from or related to your use of, or reliance on, the Tool or any information obtained therein. To the fullest extent permitted by law, you agree to release and hold harmless ASCE from any and all liability of any nature arising out of or resulting from any use of data provided by the ASCE 7 Hazard Tool.

GENERAL DYNAMICS
Information Technology

Ms. Melissa Browning
General Dynamics Information Technology, Inc.
19240 Des Moines Memorial Drive South, Suite 300
SeaTac, WA 98148
(360) 485-7196



MORRISON HERSHFIELD

Morrison Hershfield
1455 Lincoln Parkway, Suite 500
Atlanta, GA 30346
(770) 379-8500

Date: October 18, 2019

Subject: Load Mapping Report

AT&T Designation:

Site FA: 10029581
Site Name: GOOD SAMARITAN

Turf Vendor Number: WA6659

Site Address: 407 14th Ave Southeast, Puyallup, WA 98371
Site Coordinates: Latitude: 47.17950° N, Longitude: 122.29055°W

Tower Description: 68 ft – Building
Mount Description: Roof Top Platform

Morrison Hershfield Project Number: GED-577R4 / 1900279.00

Site mapping letter which shows equipment platform location on the existing roof framing and some cabinet weights.

Dear Ms. Browning,

Morrison Hershfield is pleased to submit this “**Load Mapping Report**” for the existing equipment located on the roof top mounted platform, at the above building site. This letter is in response to the letter by the building owner’s structural review consultant, PCS Structural Solutions (PCS), dated August 22, 2019.

Item 1 of the PCS letter suggests that “the existing enclosure was not designed per the requirements of the Risk Category IV that is required for equipment that is being supported off the emergency electrical generation system of the hospital.” We feel that it is not necessary, since the telecommunications equipment does not support emergency operations, or any operations of the hospital. Therefore, the equipment is “down stream” of the hospital equipment, and doesn’t require Risk Category IV design. The International Building Code references ANSI-TIA 222 revision H, for the design of telecommunications support structures, in which Section 2.2.2.1 allows for use of Risk Category II in such cases as this, where non-critical equipment is supported by structures of higher Risk Category. Our understanding is that the equipment platform was designed using Risk Category III, based upon the review of the Smartlink Structural Analysis Report, dated October 28, 2015, for analysis of the structural platform.

Item 2 of the PCS letter requests that the weights of the existing AT&T platform equipment be provided for review. Subsequently, Shawn Stevenson, SE, with MH called and discussed this item with Donald Scott, SE, with PCI to make sure we could address this concern appropriately. Shawn then visited the project site to map the equipment and any roof top building loads in the area of concern. The following pages include layout sketches with equipment information confirmed on site, along with the weights, as requested. We understand that PCS will be reviewing this information and report back to the building owner and project team with their findings.

We at *Morrison Hershfield* appreciate the opportunity of providing our continuing professional services to you and General Dynamics Information Technology, Inc. If you have any questions or need further assistance on this or any other projects please give us a call.

Respectfully submitted by:
Morrison Hershfield

Shawn W. Stevenson, S.E. (WA License No. 42002)
Senior Engineer

Morrison Hershfield

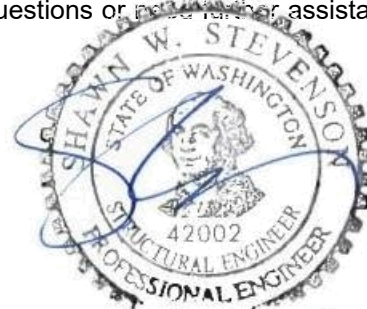

Exp 3/1/20

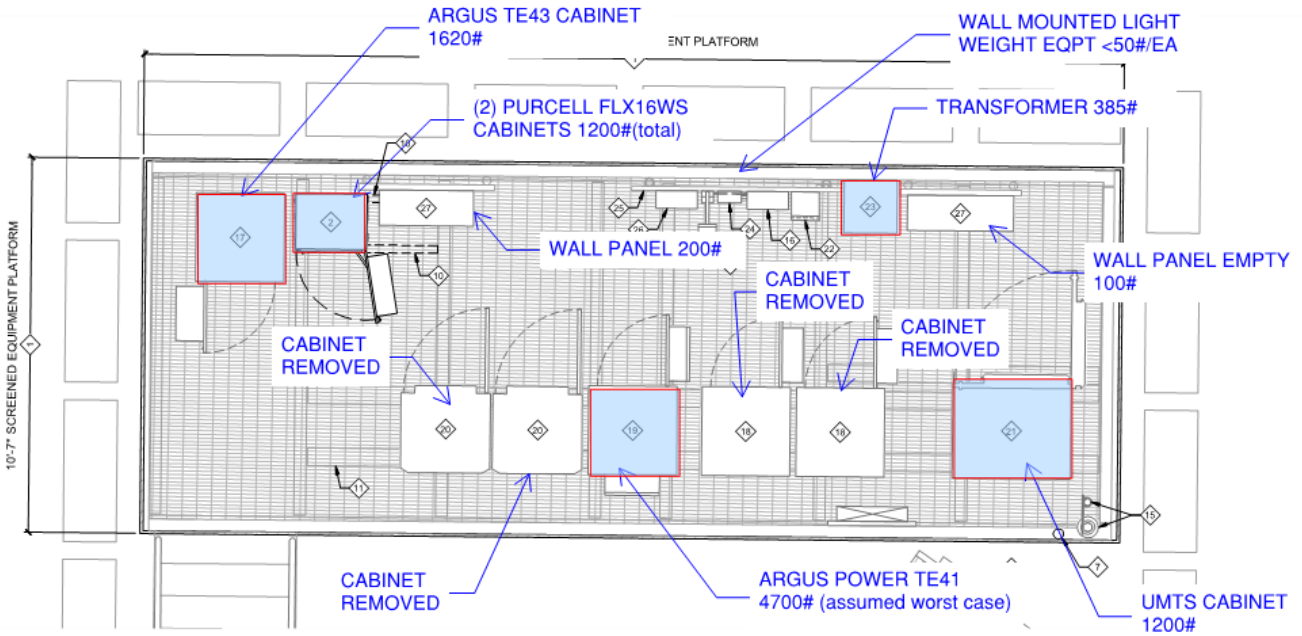

AT&T PLATFORM MAP

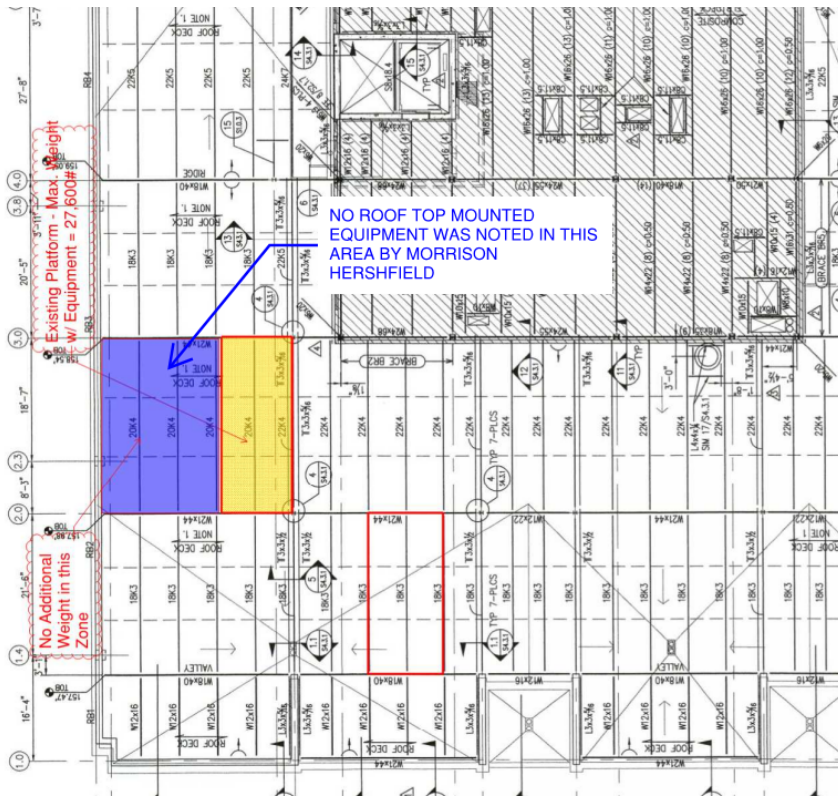

BUILDING ROOF TOP PARTIAL PLAN

Note: this sketch was part of an attachment to the PCI structural review letter, dated August 22, 2019. Morrison Hershfield notes have been added in blue.



2011 equipment configuration showing many cabinets. Some existing and new framing shown for the purcell cabinets.

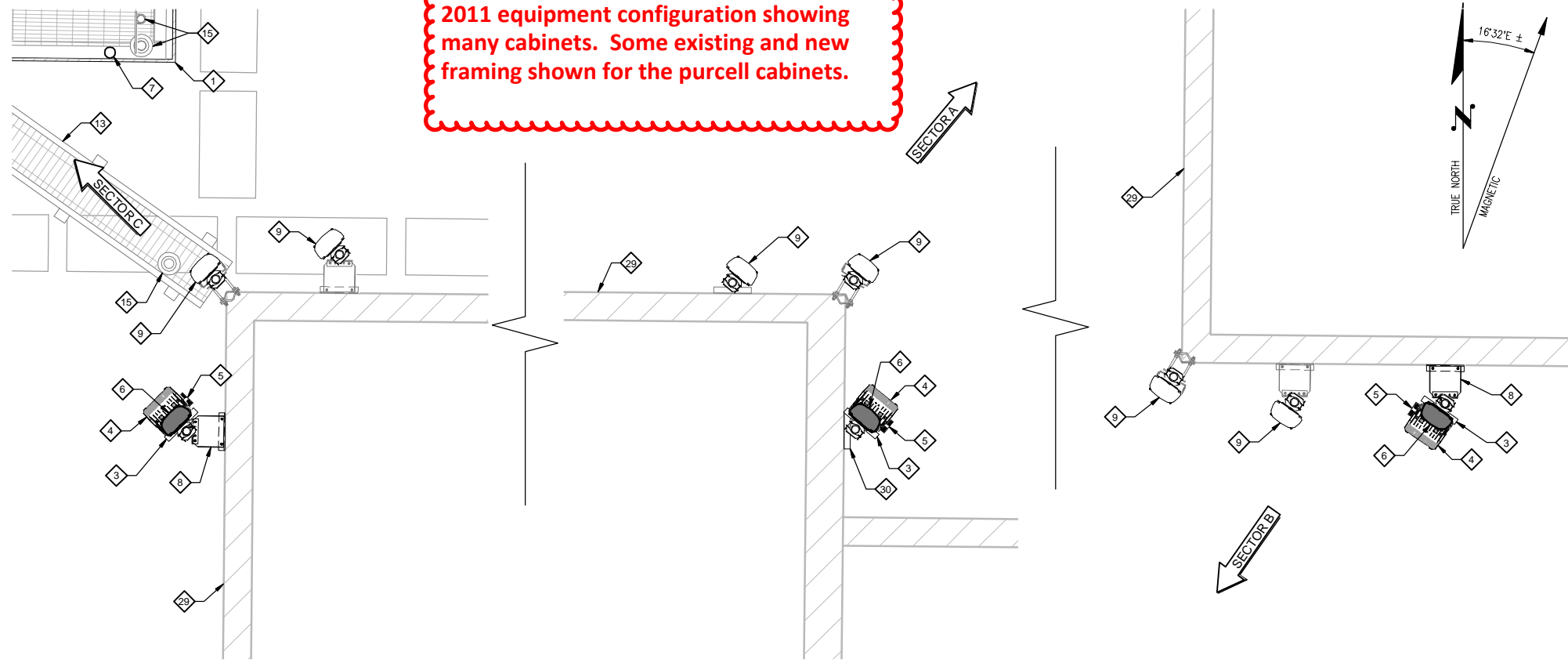

ENLARGED ANTENNA PLAN

22"x34" SCALE: 1/2" = 1'-0" 11"x17" SCALE: 1/4" = 1'-0"

2

CONSTRUCTION PLAN KEYED NOTES

- 1 EXISTING AT&T SCREENED EQUIPMENT PLATFORM (27' x 10').
- 2 PROPOSED AT&T PURCELL FLX16WS CABINET TO HOUSE LTE EQUIPMENT.
- 3 PROPOSED AT&T RAYCAP SURGE SUPPRESSION BOX MOUNTED BELOW RRH'S ON PROPOSED ANTENNA MOUNT (TYP OF (1) PER SECTOR).
- 4 PROPOSED AT&T 700 MHZ RRH UNIT MOUNTED BELOW ANTENNA ON PROPOSED ANTENNA MOUNT (TYP OF (1) PER SECTOR).
- 5 PROPOSED AT&T AWS RRH UNIT MOUNTED BELOW ANTENNA ON PROPOSED ANTENNA MOUNT (TYP OF (1) PER SECTOR).
- 6 PROPOSED AT&T LTE PANEL ANTENNA TO BE ADDED TO AN EXISTING (3) SECTOR ANTENNA ARRAY (1) LTE ANTENNA PER SECTOR FOR A TOTAL OF (3) NEW LTE ANTENNAS.
- 7 PROPOSED AT&T LTE GPS ANTENNA MOUNTED NEXT TO EXISTING GPS ANTENNA WITHIN SCREENED EQUIPMENT PLATFORM.
- 8 PROPOSED AT&T SLIDER BRACKET WALL MOUNT.
- 9 EXISTING AT&T PANEL ANTENNAS (TO REMAIN).
- 10 PROPOSED AT&T EQUIPMENT SUPPORT BEAM.
- 11 EXISTING AT&T EQUIPMENT SUPPORT BEAM (TO REMAIN).
- 12 EXISTING AT&T CABLE TRAY (TO REMAIN).
- 13 EXISTING AT&T GPS ANTENNAS (TO REMAIN).
- 14 EXISTING AT&T AC PANEL (TO REMAIN).
- 15 EXISTING AT&T ARGUS TE43 CABINET (TO REMAIN).
- 16 EXISTING AT&T BBU CABINET (TO REMAIN).
- 17 EXISTING AT&T ARGUS POWER CABINET (TO REMAIN).
- 18 EXISTING AT&T GSM CABINET (TO REMAIN).
- 19 EXISTING AT&T UMTS CABINET (TO REMAIN).
- 20 EXISTING AT&T GEN PLUG ENCLOSURE (TO REMAIN).
- 21 EXISTING AT&T TRANSFORMER (TO REMAIN).
- 22 EXISTING AT&T SURGE SUPPRESSION BOX (TO REMAIN).
- 23 EXISTING AT&T UTILITY H-FRAME (TO REMAIN).
- 24 EXISTING AT&T TELCO DEMARC (TO REMAIN).
- 25 EXISTING AT&T HOFFMAN BOX (TO REMAIN).
- 26 EXISTING AT&T WATERPROOF SERVICE LIGHT (TO REMAIN).
- 27 EXISTING PENTHOUSE (TO REMAIN).
- 28 PROPOSED AT&T CANTILEVER WALL MOUNT.

SITE NOTES

- 1. VERIFY ANTENNA MODEL, RAD CENTER & AZIMUTHS WITH LOCKDOWN SET RF SITE BUILD FORM.

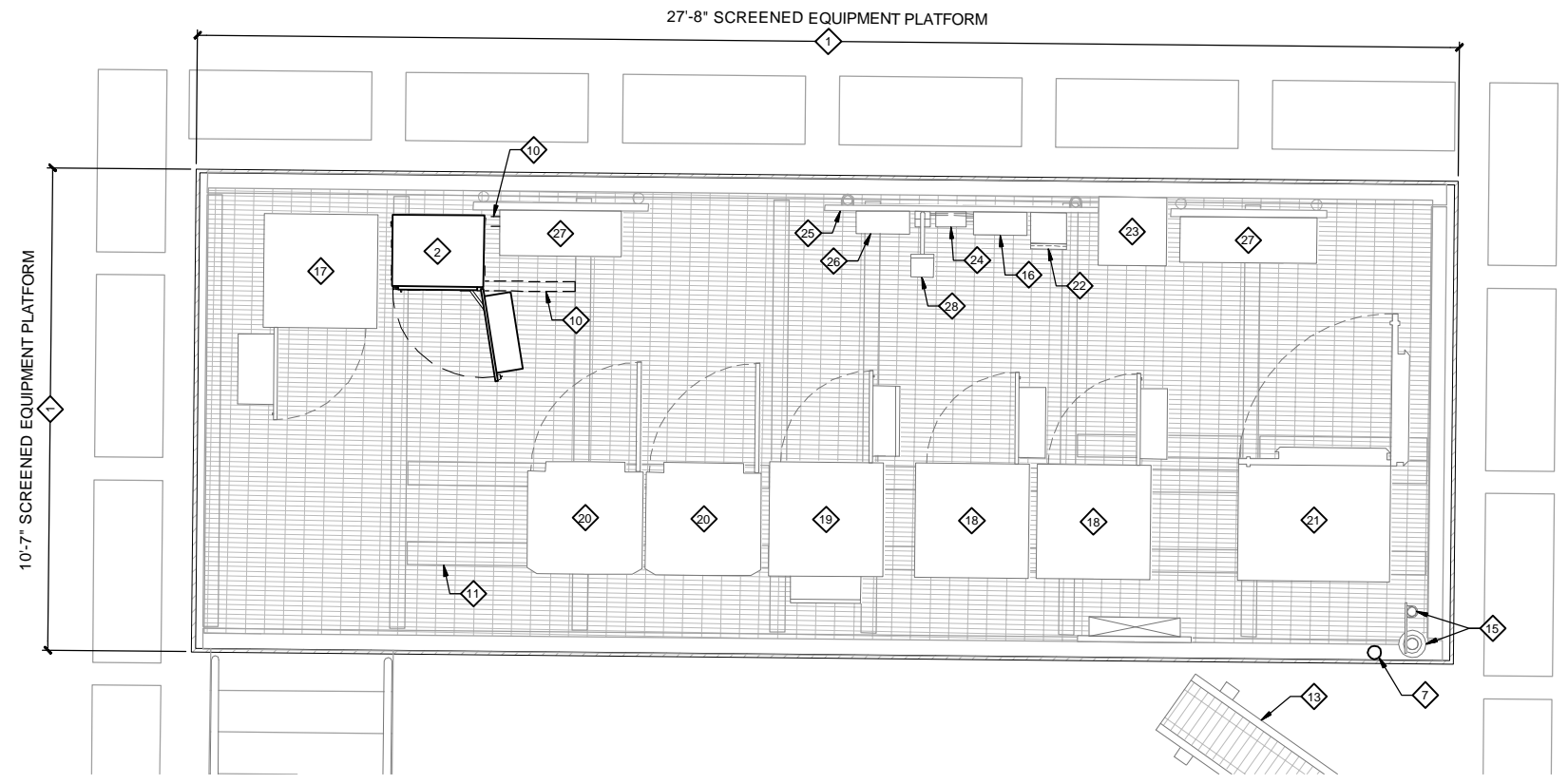

ENLARGED EQUIPMENT PLAN

22"x34" SCALE: 1/2" = 1'-0" 11"x17" SCALE: 1/4" = 1'-0"

1



LDC Commercial Infrastructure Residential Telecom
 THE CIVIL ENGINEERING GROUP
 14201 NE 200th St., #100 Ph. 425.806.1889
 Woodinville, WA 98072 Fx. 425.462.2893
 www.LDCcorp.com

DATE:	9-16-11
DRAWN BY:	RMD
CHECKED BY:	RJA

REVISIONS			
REV	DATE	DESCRIPTION	BY
1	9-16-11	PRELIMINARY CONSTRUCTION	RJA
2	12-13-11	FINAL CONSTRUCTION	RJA



SITE
 WA659
 GOOD SAMARITAN
 407 14TH AVE SE
 PUYALLUP, WA 98372

SHEET TITLE
 ENLARGED SITE PLAN

SHEET NUMBER
A-2

Drawing: P:\2011\Telecom\11-256 AT&T - WA659 Good Samaritan\Drawings\Construction\11-256 CD-A2-0.dwg Plotted: Dec 16, 2011 - 8:30am

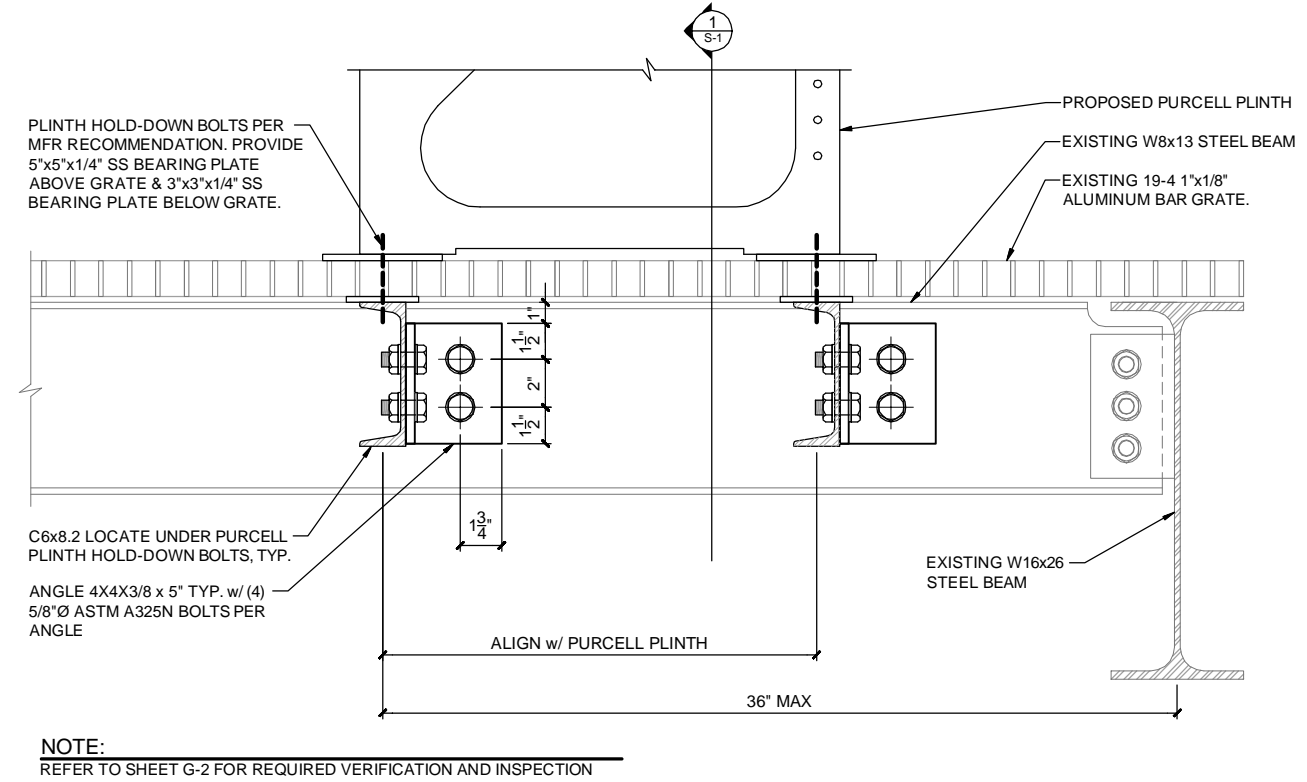
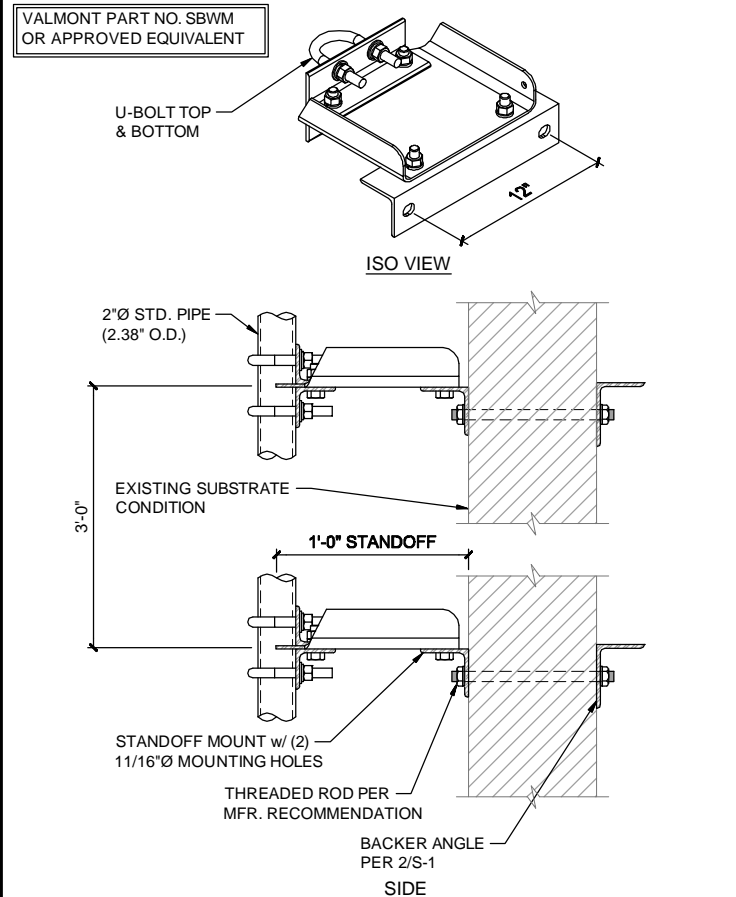
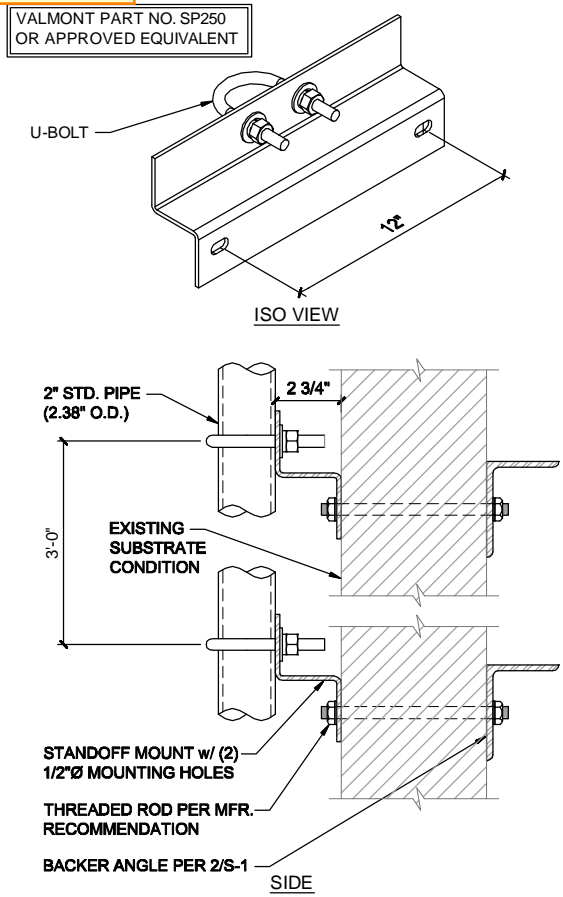

CANTILEVER WALL MOUNT
22"x34" SCALE: 3" = 1'-0"

SLIDER BRACKET WALL MOUNT
22"x34" SCALE: 2" = 1'-0"

AT&T EQUIPMENT SUPPORT BEAM
22"x34" SCALE: 3" = 1'-0"

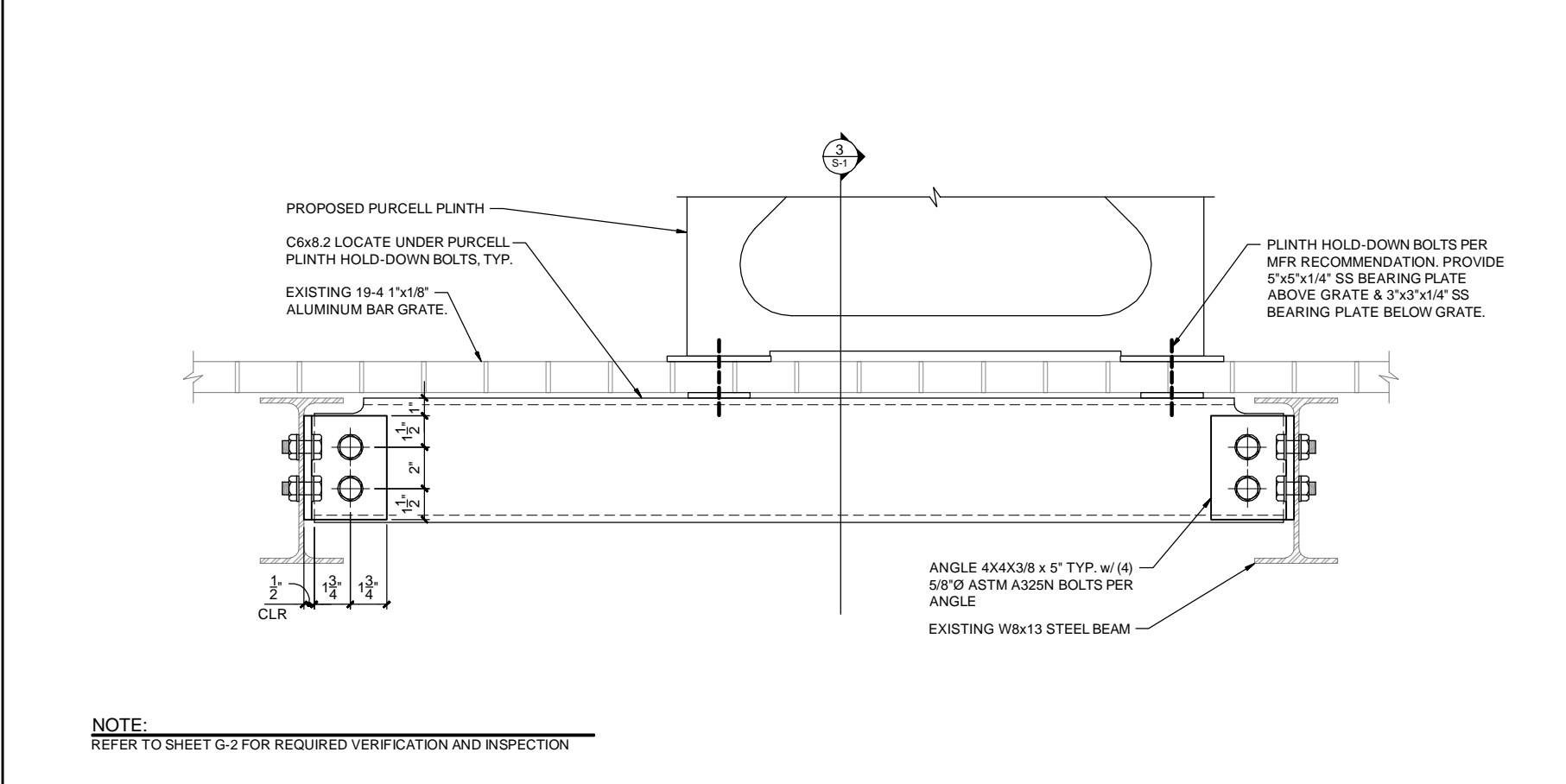
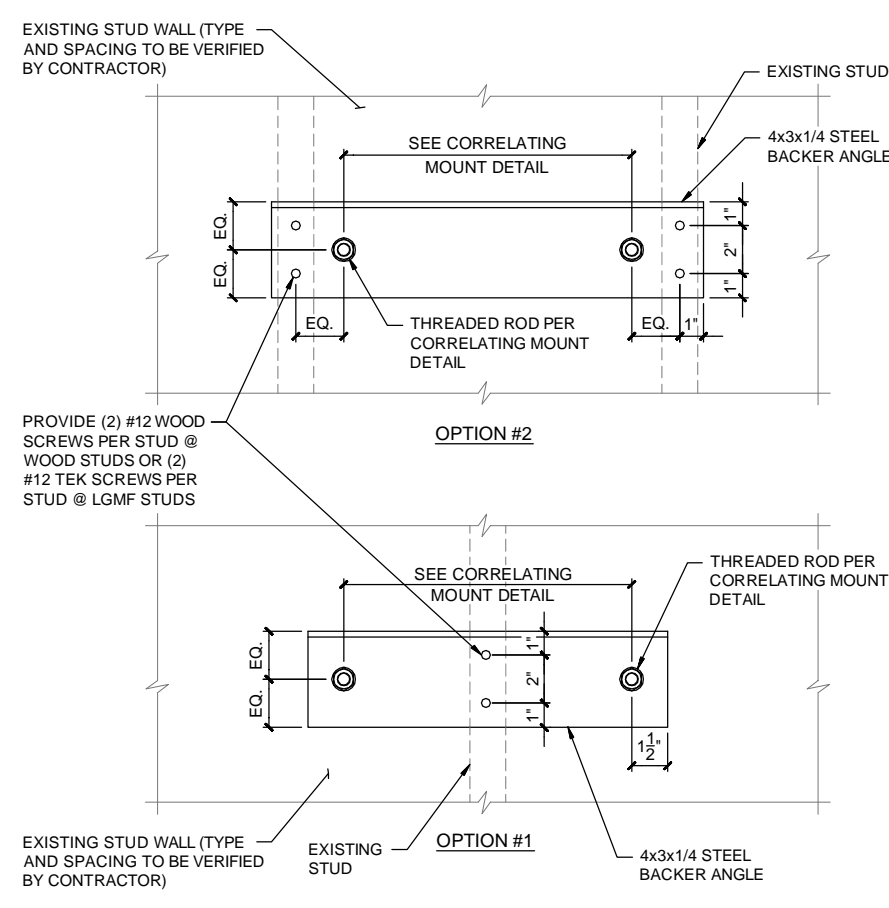

BACKER ANGLE REQUIREMENTS
22"x34" SCALE: 3" = 1'-0"

AT&T EQUIPMENT SUPPORT BEAM
22"x34" SCALE: 3" = 1'-0"



LDC Commercial Infrastructure Residential Telecom
THE CIVIL ENGINEERING GROUP
14201 NE 200th St., #100 Ph. 425.806.1889
Woodinville, WA 98072 Fx. 425.462.2893
www.LDCcorp.com

DATE: 9-16-11
DRAWN BY: RMD
CHECKED BY: RJA

REVISIONS			
REV	DATE	DESCRIPTION	BY
1	9-16-11	PRELIMINARY CONSTRUCTION	RJA
2	12-13-11	FINAL CONSTRUCTION	RJA



SITE
WA659
GOOD SAMARITAN
407 14TH AVE SE
PUYALLUP, WA 98372

SHEET TITLE
STRUCTURAL DETAILS

SHEET NUMBER
S-1

Drawing: P:\2011\Telecom\11-256 AT&T - WA659 Good Samaritan\Drawings\Construction\11-256 CD-S1-0.dwg Plotter: Dec 16, 2011 - 8:31am

2011 calculations for equipment
configuration showing many cabinets.

December 13, 2011

AT&T Mobility Corporation
c/o: Paul Long
Goodman Networks
8815 122nd Ave NE
Kirkland, WA 98033

RE: **Level 1 Structural Analysis**
WA659 Good Samaritan
407 14th Ave. SE
Puyallup, WA 98372

I. Introduction

At the request of Goodman Networks, we have performed a structural analysis and design of the existing cabinet platform, roof beam, and the new antenna masts and mounts at WA659 Good Samaritan in Puyallup, Washington. The evaluation was completed in conformance with the 2009 International Building Code, the Steel Construction Manual (AISC 13) and the American Society of Civil Engineers Standard 7-05 (ASCE/SEI 7-05) under the following site specific conditions:

Basic Wind Speed: 85 mph
Exposure Category: B
Occupancy Category: IV
Seismic Site Class: D

Based on a visual inspection performed on September 1, 2011 the existing cabinet platform appears to be relatively free of corrosion. This evaluation assumes that the cabinet platform was installed per the original design and has received proper maintenance since it was constructed. Two previous analyses were reviewed for our evaluation and design. One was by TRK Engineering dated May 11, 2006, and the other was by Velocitel, Inc. dated August 12, 2010.

The following sections detail the existing and proposed configurations in the areas subject to change.

II. Existing Antenna Configuration

Sector	Antenna Model	Antenna Weight	Effective Area
X	Vacant	N/A	N/A
Y	Vacant	N/A	N/A
Z	Vacant	N/A	N/A

III. Proposed Antenna Configuration

Sector	Antenna Model	Antenna Weight	Effective Area
X	KMW AM-X-CD-17-65-00T-RET	59.5 lbs	7.87 sf
Y	KMW AM-X-CD-14-65-00T-RET	36.4 lbs	3.93 sf
Z	KMW AM-X-CD-17-65-00T-RET	59.5 lbs	7.87 sf

Additional Appurtenances:

1. Mount an Alcatel-Lucent RRH 700MHz unit, and an Alcatel-Lucent RRH AWS unit on the new antenna mast at each new KMW antenna
2. Add Purcell FLX12WS, FLX16WS and a 14" plinth to the existing equipment platform.

IV. Conclusion

The subject antenna masts will be 2-inch diameter standard pipe (2.375" O.D.), and the mount bases are assumed to be Valmont Part Number SP250 in Sector X, and Valmont part number SBWM in Sectors Y and Z. Different mounts were used in order to match the existing mounts in the relevant sector. Wind was the controlling load, and the 2-inch pipe masts were judged to be structurally adequate to support the loading in conformance with IBC Chapters 16 and 22. Sail areas were calculated for wind from the front and the side of the antennas. For frontal area the RRH units were assumed to be shielded by the antenna. For side area, a 2" diameter pipe the length of the antenna was added to the side areas of the antenna plus the RRH units. Our evaluation compared proposed gravity plus wind loading with the design capacity of the system. The 2" diameter antenna mast was included in the gravity load. Seismic loads were calculated, but did not control.

The existing roof beam and equipment platform are adequate to support the weight of the new Purcell cabinets and plinth. C6X8.2 channels must be added to the platform to carry the new load because the existing aluminum bar grate which floors the platform lacks sufficient capacity to carry the cabinets without additional support.

LDC must be notified immediately if site conditions are found to vary from our assumptions because additional analysis and design may be necessary.

Our calculations are attached.

Please contact the undersigned with any questions relating to this work.

LDC, Inc.



David Ohnsager, P.E., S.E.

**AT&T
WA659
Good Samaritan**

***Structural Calculations:
Cabinet Platform and New Antenna Mounts***

Prepared for

*AT&T Mobility Corporation
c/o: Paul Long
Goodman Networks
8815 122nd Ave NE
Kirkland, WA 98033*

Prepared by

LDC, Inc.
14201 NE 200th Street, Suite 100
Woodinville, WA 98072
(425) 806-1869

Engineering Review:
David Ohnsager, P.E., S.E.



December 13, 2011

Job No: 11-256

WA659 Good Samaritan
407 14th Ave. SE, Puyallup WA 98372

Design Criteria

Wind Loading:

Basic Wind Speed:	85 mph
Exposure Category:	B
Occupancy Category:	IV

Seismic Loading:

IBC Site Soil Classification:	D
Seismic Design Category:	D
Occupancy Category:	IV

WA659 Good Samaritan

407 14th Ave SE Puyallup, WA 98372

Project: 11-256

Page: /
 Engineer: DAO
 Date: 11/9/2011

LDC**Project Description**

1. Add KMW AM-X-CD-17-65-00T-RET LTE panel antennas to sectors X and Z
2. Add KMW AM-X-CD-14-65-00T-RET LTE panel antennas to sector Y
3. Add Alcatel-Lucent RRH 700 MHz and RRH AWS to the antenna masts at new KMW antennas

Equipment Dimensions and Weights

	Height (inch)	Width (inch)	Depth (inch)	Front Area (ft ²)	Side Area (ft ²)	Weight (#)
Alcatel Lucent RRH 700 MHz	21.0	12.2	10.8	1.78	1.58	51.0
Alcatel-Lucent RRH AWS	24.4	10.6	6.7	1.80	1.14	43.0
KMW AM-X-CD-14-65-00T-RET	48.0	11.8	5.9	3.93	1.97	36.4
KMW AM-X-CD-17-65-00T-RET	96.0	11.8	6.0	7.87	4.00	59.5
Mounting Hardware (Assumed)						13.0

Total On Antenna Mast:

	Front Area	Side Area	Weight
KMW 14-65 LTE Antenna + RRH Units:	3.9 ft ²	5.47 ft ²	223.0 #
KMW 17-65 LTE Antenna + RRH Units:	7.9 ft ²	8.29 ft ²	260.8 #

- Notes:
1. Front Area assumes both RRH's are mounted behind and shielded by antenna
 2. Side Area assumes Antenna and RRH areas are additive, and includes a 2" std pipe the length of the antenna
 3. Weight includes six sets of mounting hardware plus assumed antenna mast

Seismic

Latitude: 47° 10' 46.23" N (47.179508° N) (From Google Earth)

Longitude: 122° 17' 25.15" W (122.290319° W) (From Google Earth)

Ss = 1.180 (From USGS Seismic Hazard App. V 5.1)

S1 = 0.400 (From USGS Seismic Hazard App. V 5.1)

WA659 Good Samaritan

407 14th Ave SE Puyallup, WA 98372

Project: 11-256

 Page: 2
 Engineer: DAO
 Date: 11/9/2011
LDC**Description:** Loads on Rooftop Antenna Mounts and Cabinets**Codes:** 2009 International Building Code (IBC-09), ASCE 7-05, AISC 13th Edition**Wind Criteria:**

Building Height to Roof = 85.33 ft
 Occupancy Category IV (ASCE 7 Table 1-1 Hospital)
 Surface Roughness = B (ASCE 7 Section 6.5.6.2)
 Exposure Category = B (ASCE 7 Section 6.5.6.3)
 Basic Wind Speed, V (mph) = 85.00 (3 sec gust per ASCE 7 Fig 6-1)
 Exposure Case = 1 (ASCE 7 Table 6-3)
 Directionality Factor, Kd = 0.90 (Square, ASCE 7 Table 6-4)
 Topographic Factor, Kzt = 1.00 (ASCE 7 Section 6.5.7)
 Gust Factor, G = 0.85 (ASCE Section 6.5.8.1 worst case)
 h/D = 8.000 (Component Height/Width for finding Cf)
 Force Coefficient, Cf = 1.433 (ASCE 7 Fig 6-21 Square, Normal to Face)

Seismic Criteria:

Latitude: 47° 10' 46.23" N (47.179508° N)
 Longitude: 122° 17' 25.15" W (122.290319° W)
 Zip Code:
 Site Class: D
 Component Amplification Factor, ap = 1.00 (ASCE 7 Table 13.6-1)
 Component Response Modification Factor, Rp = 2.50 (ASCE 7 Table 13.6-1)
 Component Importance Factor, Ip = 1.50 (ASCE 7 13.1.3)

Project: **WA659 Good Samaritan**
 407 14th Ave SE Puyallup, WA 98372
 Project: **11-256**

Page: **3**
 Engineer: **DAO**
 Date: **11/9/2011**



Description: Loads on Rooftop Antenna Mounts and Cabinets

Seismic Load Calculation for Components and System

(Derived from IBC-09 and ASCE 7)

Location for Input to USGS Seismic Hazard Application

Latitude: 47° 10' 46.23" N (47.179508° N)
 Longitude: 122° 17' 25.15" W (122.290319° W)
 Zip Code: 0

Seismic Ground Motion:

0.2s Spectral Response Acceleration, Site Class B, **S_s**
 1.0s Spectral Response Acceleration, Site Class B, **S₁**
 Site Class
 Occupancy Category

1.180	(from USGS App)
0.400	(from USGS App)
D	(ASCE Table 20.3-1)
IV	(IBC Table 1604.5)

Calculated Values

Site Coefficient per S_s & Site Class, **F_a**
 Site Coefficient per S₁ & Site Class, **F_v**
S_{MS} = F_aS_s
S_{M1} = F_vS₁
S_{DS} = 2/3S_{MS}
S_{D1} = 2/3S_{M1}
 Seismic Design Category per S_{DS}

1.028	(ASCE Table 11.4-1)
1.600	(ASCE Table 11.4-2)
1.213	(ASCE Eqn 11.4-1)
0.640	(ASCE Eqn 11.4-2)
0.809	(ASCE Eqn 11.4-3)
0.427	(ASCE Eqn 11.4-3)
D	(ASCE Table 11.6-1)

Seismic Design Requirements for Nonstructural Components:

Height in Structure at Component Point of Attachment, **z**
 Component Operating Weight, **W_p**
 Component Amplification Factor, **a_p**
 Component Response Modification Factor, **R_p**
 Component Importance Factor, **I_p**
 Average Roof Height of Structure, **h**

81.17	ft
265.00	lb
1.00	(ASCE Table 13.5-1 or 13.6-1)
2.50	(ASCE Table 13.5-1 or 13.6-1)
1.50	(ASCE Sec 13.1.3)
85.33	ft

Seismic Design Force, **F_p** = $\frac{0.4a_p S_{DS} W_p (1+2z/h)}{R_p / I_p}$ (ASCE Eqn 13.3-1)

Max Seismic Design Force, **F_{pmax}** = **1.6S_{DS}I_pW_p** (ASCE Eqn 13.3-2)

Min Seismic Design Force, **F_{pmin}** = **0.3S_{DS}I_pW_p** (ASCE Eqn 13.3-3)

Seismic Design Force, F_p	0.563 W _p (ULT)
Max Seismic Design Force, F_{pmax}	1.941 W _p
Min Seismic Design Force, F_{pmin}	0.364 W _p

Seismic Design Force, F_p	0.563 W _p (ULT) =	149.28 lb
Seismic Design Force, F_p	0.402 W _p (ASD) =	106.63 lb

WA659 Good Samaritan
 407 14th Ave SE Puyallup, WA 98372
 Project: **11-256**

Page: **4**
 Engineer: **DAO**
 Date: **11/9/2011**



Description: Loads on Rooftop Antenna Mounts and Cabinets

Wind Load Calculation for Other Structures

(Derived from IBC-09 and ASCE 7-05)

Wind Velocity Pressure:

V =	85.00	mph	Basic Wind Speed (3 second gust, ASCE 7-05 Fig. 6-1))
V' =	85.00	mph	(from ASCE 7-05 Figure 6-1)
h =	85.33	ft	(Building Roof Height)
Delta _h =	6.92	ft	Height Increment for Pressure Calculation
Case =	1		(from ASCE 7-05 Table 6-3)
Exposure =	B		(from ASCE 7-05 Section 6.5.6.3)
K _d =	0.900		(Directionality Factor from ASCE 7-05 Table 6-4)
K _{zt} =	1.000		(Topographic Factor from ASCE 7-05 Section 6.5.7)
I _w =	1.150		(Importance Factor from ASCE 7-05 Table 6-1)
G =	0.850		(Gust Factor from ASCE 7-05 Section 6.5.8)
C _f =	1.433		(Force Coefficient from ASCE 7-05 Figure 6-20, 6-21, 6-22 or 6-23)
C _{f2} =	0.000		(Rooftop Equipmt. Increase per ASCE 7-05 Section 6.5.15.1)
Reduction =	0.000	%	(from ASCE 37-02 6.2.1)

Calculated Values

q =	19.14	psf	(from ASCE 7-05 6.5.10: $q = 0.00256 * K_d * K_{zt} * V^2 * I_w$)
G * C _f =	1.218		
alpha =	7.00		(from ASCE 7-05 Table 6-2)
z _g =	1200.00		(from ASCE 7-05 Table 6-2)

$q_z = q * K_z * G * C_f$ with K_z per ASCE 7-05 Table 6-3, Note 2

A = Projected Area at height z

Pressures and Forces at Z feet Above Grade					
z (ft)	K _z	q _z (psf)	A (ft ²)	F (lb)	F (kips)
30.00	0.70	16.34	1.00	16.3	0.02
36.92	0.74	17.34	1.00	17.3	0.02
43.83	0.78	18.21	1.00	18.2	0.02
50.75	0.81	18.99	1.00	19.0	0.02
57.67	0.84	19.69	1.00	19.7	0.02
64.58	0.87	20.34	1.00	20.3	0.02
71.50	0.90	20.94	1.00	20.9	0.02
78.42	0.92	21.50	1.00	21.5	0.02
85.33	0.94	22.03	1.00	22.0	0.02
81.17	0.93	21.71	1.00	21.7	0.02
Total =				197	0.20

(Z per ASCE 7-05 Table 6-3 Note 2)

(Building Roof)

(Point of Interest)

Project: WA659 Good Samaritan
 LDC #: 11-256 Date: 11/10/11 Engineer: DAO Page: 5 of 19

14201 NE 200th St., #100 • Woodinville, WA 98072 • ph: 425.806.1869 • fx: 425.482.2893

LDC
www.LDCcorp.com

Antenna Mast

Loads

Gravity

$$\text{Say } P = 265 \# \text{ (Worst Case)}$$

Lateral

Seismic

$$F_p = 106.6 \#$$

Wind

$$W = 21.7 \Rightarrow 22 \text{ psf}$$

$$A_w = 8.29 \text{ ft}^2 \text{ (Worst Case)}$$

$$F_w = W \times A_w = 22 \times 8.3 = 182.6 \Rightarrow 190 \# \leftarrow \text{Controls}$$

Moment

Assume Mast is 8' cantilever (very conservative)

$$\therefore M = F_w l/2 = 190 \times 4 = 760 \# \text{-ft.}$$

$$M = 0.76 \text{ K-ft.} \Rightarrow 0.8 \text{ K-ft.}$$

Mast Size

From analysis 2" Std. Pipe (2.38" O.D.) is OK

WA659 Good Samaritan
 407 14th Ave SE Puyallup, WA 98372
 Project: 11-256

Page: 6
 Engineer: DAO
 Date: 11/10/2011



Description: Antenna Mast: 2" Standard Pipe (O.D. = 2.38", Design Wall Thickness = 0.143")

Compression and Flexure in Pipe and Rods per AISC 13th Edition Sections E3 and F8

Loads (ASD or LRFD) = **ASD**

Pr = 0.270 k
 Mr = 0.800 k-ft

Dimensions

D = 2.375 in (Outside Diameter)
 t = 0.143 in (Design Wall Thickness)
 Fy = 35.000 ksi
 E = 29000.000 ksi
 Lu = 8.000 ft
 k = 2.000

Calculated Properties

di = 2.089 in (Inside Diameter)
 D/t = 16.608
 Ag = 1.003 in²
 I = 0.627 in⁴
 r = 0.791 in
 S = 0.528 in³
 Z = 0.713 in³

Compression		Flexure	
Compactness		Compactness	
.11E/Fy = 91.14 (AISC 13 Table B4.1-15)		.07E/Fy = 58.00 (AISC 13 Table B4.1-15)	
Not Slender		.31E/Fy = 256.86 (AISC 13 Table B4.1-15)	
Compact			
Ωc = 1.67	Φc = 0.9	Ωb = 1.67	Φb = 0.9
Lu = 96.00 in		Yielding: Mn = FyZ	
k/r = 242.81		Mn = 24.97 k-in	(AISC 13 F8-1)
4.71sqrt(E/Fy) = 135.58		Local Buckling	
Fe = 4.85 ksi (AISC 13 E3-4)		Mn = N/A	
Fcr = 4.26 ksi (AISC 13 E3-3)			
Pn = 4.27 k (AISC 13 E3-1)			
Pc = 2.56 k (ASD)		Mc = 1.25 k-ft (ASD)	
Pc = 3.84 k (LRFD)		Mc = 1.87 k-ft (LRFD)	
Combined Loads Check			
Pr/Pc < 0.2: Use AISC 13 Eqn H1-1b:		Pr/(2Pc) + Mr/Mc = 0.695 OK	(ASD)

Project: WA 659 Good Samaritan

LDC #: 11-256 Date: 11/10/11 Engineer: DAD Page: 7 of 19

14201 NE 200th St., #100 • Woodinville, WA 98072 • ph: 425.806.1869 • fx: 425.482.2893 www.LDCcorp.com



Antenna Mounts - Existing

Use New Mounts to Match Existing

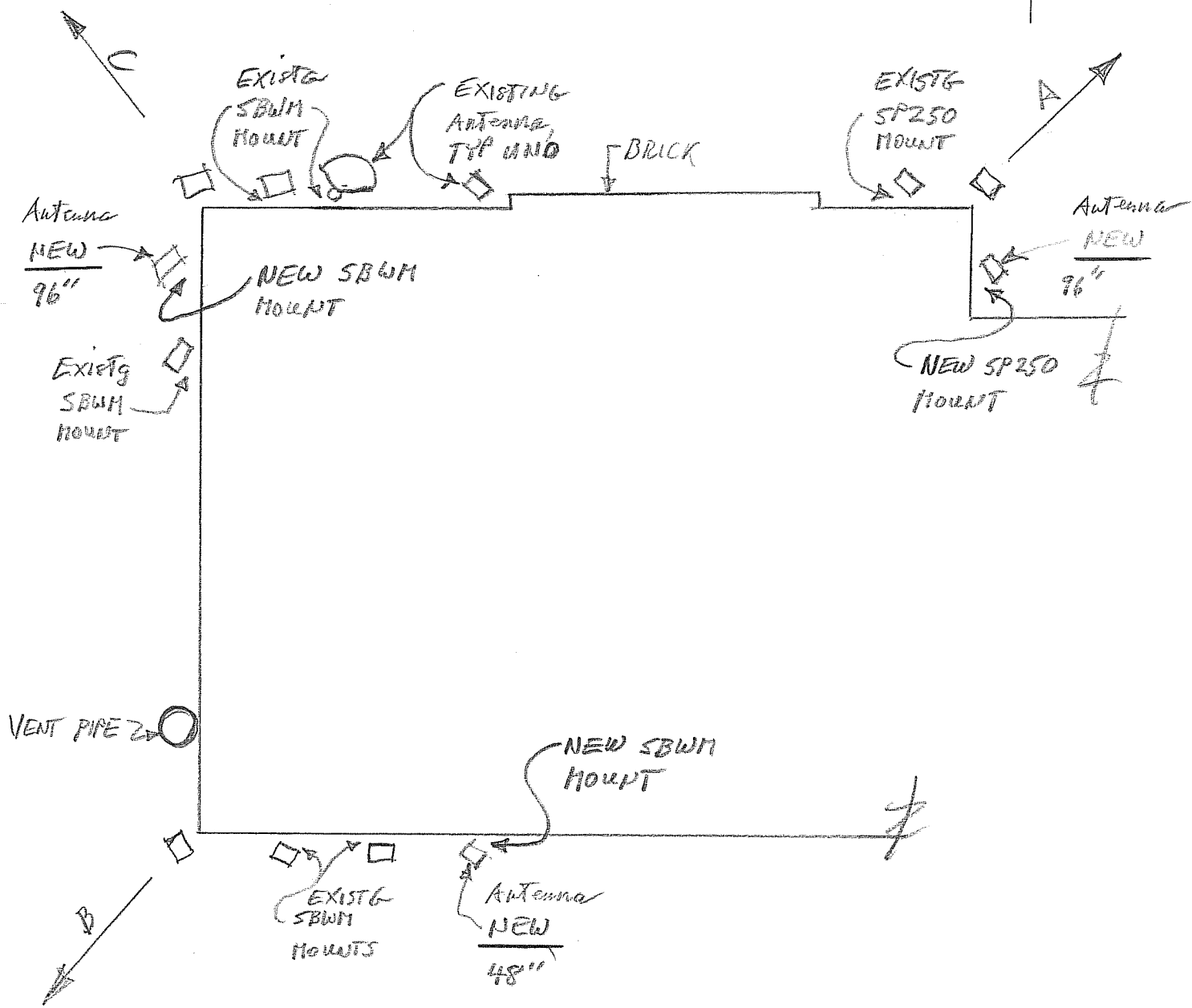

By inspection standard mounting bolts for mounts are OK

Project: WA 659 Good SamaritanLDC #: 11-256 Date: 11/10/11 Engineer: DAO Page: 8 of 19**LDC**14201 NE 200th St., #100 • Woodinville, WA 98072 • ph: 425.806.1869 • fx: 425.482.2893 www.LDCcorp.comEquipment CabinetsExisting Aluminum Bar Grate

From TRK dwg S-1, Bar grate is Fishlow 19-4 1" x 1/8" Aluminum Grate.

From Fisher & Ludlow website the safe uniform load for a 4' span 19-4 1" x 1/8" Bar Grate is 105 psf

$$\therefore M_a = Wl^2/8 = 105 \times 4^2/8 = 210 \text{ \#-ft.}$$

$$\therefore W_a = \frac{8M_a}{l^2} = \frac{8 \times 210}{l^2} = 1680/l^2 \text{ for Uniform Load/ft.}$$

$$M_a = Pl/4 \text{ for Concentrated Load}$$

$$\therefore P_a = 4M_a/l = 840/l \text{ for Concentrated Load @ Mid-Span, \#}$$

9



Brown-Campbell Company
1-800-GRATING (800-472-8464)

[Request Quote](#)

Home Products Stock Lists Locations Free Catalog

Same Day Shipments! Huge Inventory! ISO 9001:2008 Certified!

Bar Grating Home	Design Details/Accessories	Light Duty Carbon	Aluminum	Stair Treads	Bar Grating Calculator
Stock List	Types/Construction	Heavy Duty Carbon	Stainless Steel	Load Tables	How To Order

19-4/19-2 Aluminum Rectangular Bar Load Table & Panel Width Chart

•Load Table
•Panel Width Chart

[Back to 'Aluminum Rectangular Bar Load Tables'](#)

Swaged - 1-3/16" Center to Center of Bearing Bars - Load Table

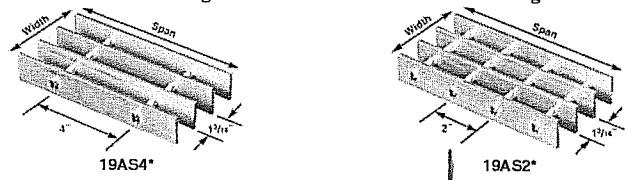

*Also available in pre-locked (19AP4/19AP2) and flush top (19AF4/19AF2). See [Load/Connection](#) for descriptions of each.

Bar Size	Symbol / Approx. Weight** Lbs/Sq. Ft.			Ped. Span	Sec. Mod. Per Ft. Of Width	Clear Span																								
	19AP4	19AS4	19AF4			2'-0"	2'-6"	3'-0"	3'-6"	4'-0"	4'-6"	5'-0"	5'-6"	6'-0"	6'-6"	7'-0"	8'-0"	9'-0"												
3/4" x 1/8"	19AP4	1.5#	n/a	31'	.118	U	237	152	105	77																				
	19AP2	1.8#	n/a			D	.192	.300	.432	.588																				
	19AS2	1.8#	n/a			C	.237	.189	.158	.135																				
						D	.154	.240	.346	.470																				
3/4" x 3/16"	19AP4	2.3#	n/a	35'	.178	U	355	227	158	118																				
	19AP2	2.8#	n/a			D	.192	.300	.432	.588																				
	19AS2	2.4#	n/a			C	.355	.384	.237	.203																				
						D	.154	.240	.346	.470																				
1" x 1/8"	19AP4	1.9#	1.8#	39'	.211	U	.421	.269	.187	.137	.105																			
	19AP2	2.2#	2.2#			D	.144	.225	.324	.441	.576																			
	19AS2	2.2#	2.2#			C	.421	.337	.281	.241	.211																			
						D	.115	.180	.259	.353	.481																			
1" x 3/16"	19AP4	2.8#	2.5#	43'	.316	U	632	404	281	206	159	125																		
	19AP2	3.3#	2.9#			D	.144	.225	.324	.441	.576	.729																		
	19AS2	3.0#	2.9#			C	632	505	421	361	316	281																		
						D	.115	.180	.259	.353	.461	.583																		
1-1/4" x 1/8"	19AP4	2.4#	2.2#	46'	.329	U	658	421	292	219	164	130																		
	19AP2	2.8#	2.6#			D	.115	.180	.259	.353	.461	.583																		
	19AS2	2.6#	2.6#			C	658	526	439	376	329	292																		
						D	.082	.144	.207	.282	.369	.467																		
1-1/4" x 3/16"	19AP4	3.5#	3.1#	51'	.493	U	987	632	439	322	247	195	158																	
	19AP2	4.3#	3.5#			D	.115	.180	.259	.353	.461	.583	.720																	
	19AS2	4.3#	3.5#			C	987	789	658	564	493	439	395																	
						D	.082	.144	.207	.282	.360	.467	.576																	
1-1/2" x 1/8"	19AP4	2.8#	2.7#	53'	.474	U	947	606	421	309	237	187	152																	
	19AP2	3.2#	3.1#			D	.095	.150	.216	.294	.384	.486	.600																	
	19AS2	3.0#	3.1#			C	947	768	632	541	474	421	379																	
						D	.077	.120	.173	.235	.307	.389	.480																	
1-1/2" x 3/16"	19AP4	4.2#	3.8#	59'	.711	U	1421	909	632	464	355	281	227	188																
	19AP2	4.8#	4.2#			D	.095	.150	.216	.294	.364	.466	.600	.726																
	19AS2	4.1#	4.2#			C	1421	1137	947	812	711	632	568	517																
						D	.077	.120	.173	.235	.307	.380	.480	.581																
1-3/4" x 3/16"	19AP4	4.8#	4.3#	65'	.967	U	1934	1230	860	632	484	382	309	256	215	183														
	19AP2	5.4#	4.7#			D	.082	.129	.185	.252	.329	.417	.514	.622	.741	.869														
	19AS2	5.4#	4.7#			C	1934	1547	1289	1105	967	860	774	703	645	595														
						D	.068	.103	.148	.202	.263	.333	.411	.498	.592	.695														
2" x 3/16"	19AP4	5.3#	4.9#	73'	1.263	U	2526	1617	1123	825	632	499	404	334	281	239	206													
	19AP2	6.0#	5.3#			D	.072	.113	.162	.221	.288	.365	.450	.545	.648	.761	.882													
	19AS2	6.0#	5.3#			C	2526	2021	1684	1444	1263	1123	1011	919	842	777	722													
						D	.058	.090	.130	.176	.230	.292	.360	.435	.519	.608	.706													
2-1/4" x 3/16"	19AP4	5.9#	5.5#	83'	1.599	U	3197	2046	1421	1044	799	632	512	423	355	303	261	200												
	19AP2	6.6#	5.9#			D	.064	.100	.144	.196	.256	.324	.400	.484	.578	.676	.784	1.024												
	19AS2	6.6#	5.9#			C	3197	2658	2132	1827	1599	1421	1279	1163	1066	984	914	859												
						D	.051	.080	.115	.157	.205	.259	.320	.387	.461	.541	.627	.819												
2-1/2" x 3/16"	19AP4	5.5#	6.0#	87'	1.974	U	3947	2526	1754	1289	987	780	632	522	458	374	322	247	155											
	19AP2	7.2#	6.4#			D	.058	.090	.130	.176	.230	.292	.360	.436	.518	.608	.705	.822	1.166											
	19AS2	7.2#	6.4#			C	3947	3158	2632	2256	1974	1754	1579	1435	1316	1215	1128	1047	977	877										
						D	.046	.072	.104	.141	.184	.233	.288	.348	.415	.487	.564	.737	.933											

U = Safe uniform load, lbs/sq ft
C = Safe concentrated load, lb/ft of grating width, at mid-span
D = Deflection in inches

Data is theoretical and based on 12,000 psi.

Install with cross rods on top.

** Weight depends on panel width, cross bar selection, mill tolerance and manufacturing tolerance.

Deflection: To ensure safe pedestrian comfort, maximum deflection (D) should be limited to 1/4" for uniform load of 100 psi (denoted by values to the left of heavy line in table above), however, this can be exceeded for non-pedestrian loading conditions at engineer's discretion.
Serrated Grating: For serrated grating, the depth of grating required for a specified load is 1/4" greater than shown in the above table.

[Back to top](#)

19-4/19-2 Panel Width Chart

10

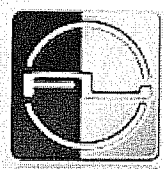

FISHER & LUDLOW
A **NUCOR** Company
ISO 9001:2008 Certified

Download Product Catalogue

- ABOUT US
- PRODUCTS
- CUSTOM FABRICATION
- REQUEST A QUOTE
- CONTACT US

PRODUCTS / Bar Grating / Aluminum Grating

Metric **Imperial**

- Bar Grating**
- Standard Grating
- Heavy Duty Grating
- Stainless Steel Grating
- Aluminum Grating**
- Stair Treads
- Manufacturing Tolerance
- Fastening Methods
- Grating Terms
- Safety Grating**
- Expanded Metals**
- Fiberglass Grating**

Fisholow Aluminum Grating

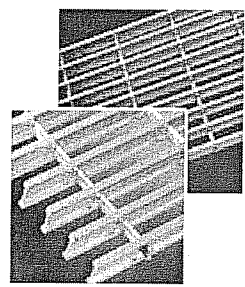

Fisholow aluminum gratings employ a unique interlocking system that joins the bearing and cross bars together in panels of exceptional rigidity and strength. Lightweight, corrosion-resistant, non-sparking alloys are ideal for pedestrian platforms in chemical, petroleum, hydro and food processing plants, in sewage, water and waste water treatment facilities. Also available in close mesh and serrated.

Standard Mesh Aluminum Grating

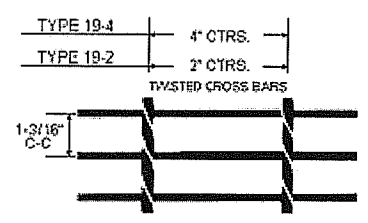

Standard Bar / I Bar - Type 19
Bearing Bars - 1-3 / 16" centers
[View Table of Safe Loads](#)

Close Mesh Aluminum Grating

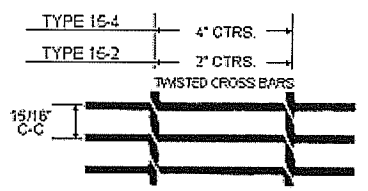

Loads, multiply values in Standard Mesh tabel above By 1.28.
Type 15P - Standard Bar
Type 15I - I Bar
[View Table of Safe Loads](#)

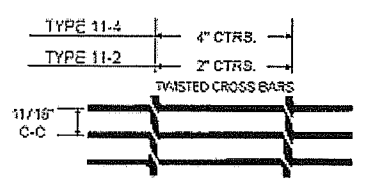

ADA Compatible with 3/16" bars
Loads, multiply values in Standard Mesh tabel above By 1.71.
Type 11P - Standard Bar
Type 11I - I Bar
[View Table of Safe Loads](#)

Table of Safe Loads - Imperial

NOTE:
Choose a span:

Bearing Bar Size inches	Weight lbs./sq.ft.		Sec. Mod. per foot of width	Span: 4'-0" inches
	Type 19-4	Type 19-2		
1 x 1/8	1.92	2.27	.210	U 105 ←
				D 0.576
				C 211 ←
1 x 3/16	2.72	3.06	.316	D 0.461
				U 158
				D 0.576
1 1/4 x 1/8	2.31	2.65	.329	C 316
				D 0.461
				D 0.369

Imperial
U = Safe Uniform Load, in lbs, per sq. ft.
C = Safe Concentrated Load, in lbs, per foot of grating width.
D = Deflection in inches.

Project: WA659 Good Samaritan
 LDC #: 11-256 Date: 11/10/11 Engineer: DAO Page: 11 of 19



14201 NE 200th St., #100 • Woodinville, WA 98072 • ph: 425.806.1869 • fx: 425.482.2893 www.LDCcorp.com

Equipment Cabinets

Purcell Cabinets + Plinth

FLX16WS = 600# H=30" W=25" D=20"

FLX12WS = 475# (Assumed) H=23" W=24" D=20"

Plinth = 100# (Assumed) H=14" W=24" D=20" (Assumed)

Seismic Loads

$F_p = .563 W_p$ (ULT)

$F_{p1} = .563 \times 600 = 338\#$

$M_{p1} = 52 \times 338 = 17576\#-in$

$F_{p2} = .563 \times 475 = 267\#$

$M_{p2} = 25.5 \times 267 = 6809\#-in$

$F_{p3} = .563 \times 100 = 56\#$

$M_{p3} = 7 \times 56 = 392\#-in$

$\Sigma F = 661\# = V_u$

$\Sigma M = 24777\#-in$

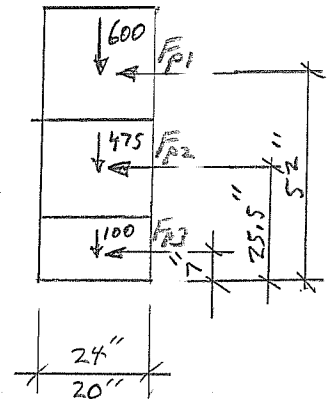

Overturning Reactions

Dead Load = $1.2D/2 = 1.2(600+475+100)/2 = 705\#$ (LRFD)

Long Way

$R = 24777/24 \pm 705 = 1032 \pm 705 \Rightarrow 1737\#$ DN, $327\#$ UP

Short Way

$R = 24777/20 \pm 705 = 1239 \pm 705 \Rightarrow 1944\#$ DN, $534\#$ UP

Project: WA 659 Good Samaritan
 LDC #: 11-256 Date: 11/10/11 Engineer: DAO Page: 12 of 19



14201 NE 200th St., #100 • Woodinville, WA 98072 • ph: 425.806.1869 • fx: 425.482.2893 www.LDCcorp.com

Platform Beams

Use Velocitel Calcs

Assume Worst Case

W8X13

Code Check = 0.397

Additional Load adds to Strong Axis Bending Only.

$M_a = 25.62 \text{ K-ft (from Velocitel Calcs)}$

$W_u = 1.2D + E = 1737/20 = 86.9 \text{ \#/in}$

$R_1 = 1737 \times (96 + 20/2) / 126$

$R_1 = 1461 \text{ \#} \quad R_2 = 1737 - 1461 = 275.7$

$\therefore M = 1461 \times 10 + 1461 \times 16.81 / 2$

$M = 26890 \text{ \#-in} = 2.24 \text{ K-ft}$

$\frac{M}{M_a} = \frac{2.24}{25.62} = 0.0874$

$0.397 + 0.087 = 0.484 < 1.0 \quad \underline{OK}$

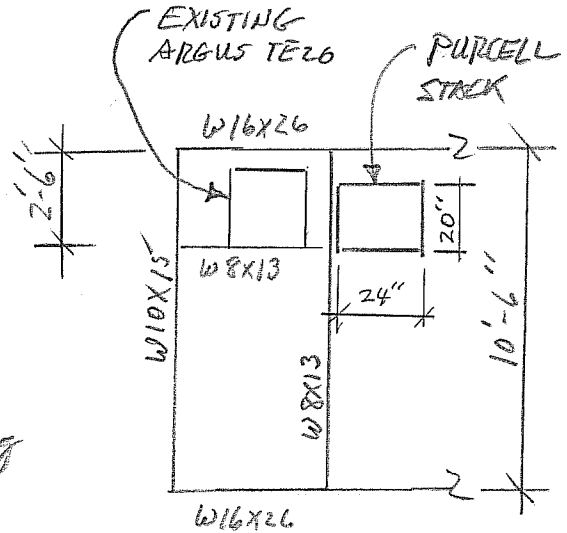

PLAN

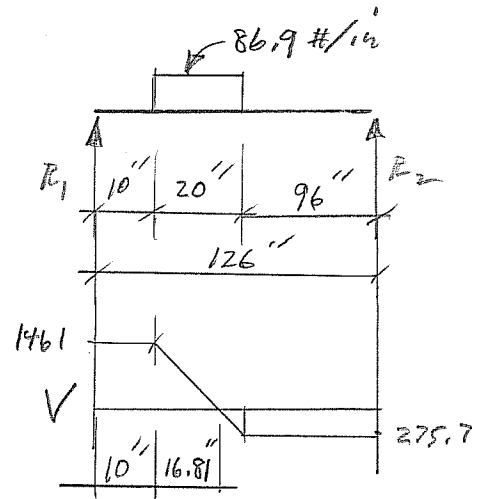

Project: WA659 Good SamaritanLDC #: 11-256 Date: 11/10/11 Engineer: DAO Page: 13 of 19

14201 NE 200th St., #100 • Woodinville, WA 98072 • ph: 425.806.1869 • fx: 425.482.2893

LDC

www.LDCcorp.com

Platform Beams, ContW10X15Not Applicable. New Purcell Cabinet does NOT load W10X15W16X26

$$M_a = 119.34 \text{ K-ft (from Velocity Calcs)}$$

$$\text{Code Check} = .803$$

$$R_1 = 23 \times 1.461 / 27 \Rightarrow 1.25 \text{ K}$$

$$R_2 = .211 \text{ K}$$

$$\therefore M = 1.25 \times 4 = 5 \text{ K-ft}$$

$$\frac{M}{M_a} = \frac{5}{119.34} = .042$$

$$\therefore \text{Code Check} = .803 + .042 = .845 < 1.0 \text{ OK}$$

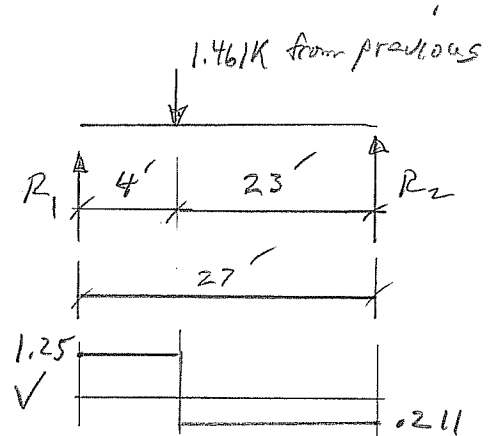

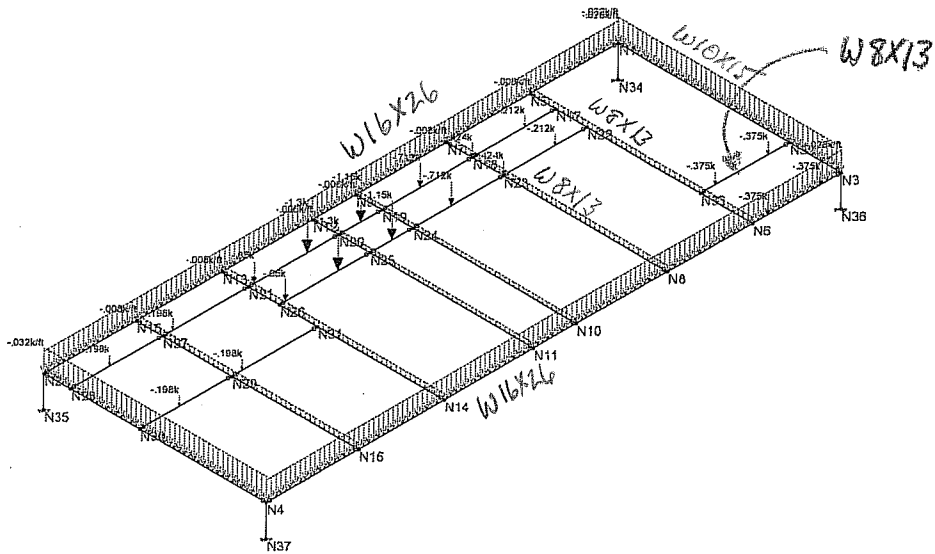

Loads: BLC 1,
Solution: Envelope

Velocitel Inc	Platform Design	
NDT		Aug 12, 2010 at 1:13 PM
10029581 - Good Samarit...		Dead Loads

Company : Velocitel Inc
 Designer : NDT
 Job Number : 10029581 - Good Samaritan Platform Design

Aug 12, 2010
 1:18 PM
 Checked By: _____

Envelope Member Section Forces (Continued)

Member	Sec		Axial[k]	LC	y Shear	LC z Shear	LC Torque	LC	y-y Moment[k-ft]	LC	z-z Moment	LC		
240		min	8.011	1	-1.412	5	0	1	0	1	0	5		
241	M25	1	max	8.368	2	0	1	1.266	4	0	1	1		
242		min	3.568	1	-1.293	5	0	1	0	1	-1.899	4	-1.94	5
243		2	max	8.363	2	0	1	1.266	4	0	1	1	0	1
244		min	3.563	1	-1.293	5	0	1	0	1	-1.424	4	-1.455	5
245		3	max	8.359	2	0	1	1.266	4	0	1	1	0	1
246		min	3.558	1	-1.293	5	0	1	0	1	-.949	4	-.97	5
247		4	max	8.354	2	0	1	1.266	4	0	1	1	0	1
248		min	3.552	1	-1.293	5	0	1	0	1	-.475	4	-.485	5
249		5	max	8.35	2	0	1	1.266	4	0	1	1	0	1
250		min	3.547	1	-1.293	5	0	1	0	1	0	4	0	5
251	M26	1	max	9.576	2	0	1	1.437	4	0	1	1	0	1
252		min	4.898	1	-1.294	5	0	1	0	1	-2.155	4	-1.941	5
253		2	max	9.572	2	0	1	1.437	4	0	1	1	0	1
254		min	4.893	1	-1.294	5	0	1	0	1	-1.616	4	-1.455	5
255		3	max	9.567	2	0	1	1.437	4	0	1	1	0	1
256		min	4.887	1	-1.294	5	0	1	0	1	-1.078	4	-.97	5
257		4	max	9.563	2	0	1	1.437	4	0	1	1	0	1
258		min	4.882	1	-1.294	5	0	1	0	1	-.539	4	-.485	5
259		5	max	9.558	2	0	1	1.437	4	0	1	1	0	5
260		min	4.877	1	-1.294	5	0	1	0	1	0	4	0	1
261	M27	1	max	11.849	2	0	1	1.438	4	0	1	1	0	1
262		min	7.549	1	-1.412	5	0	1	0	1	-2.158	4	-2.118	5
263		2	max	11.845	2	0	1	1.438	4	0	1	1	0	1
264		min	7.544	1	-1.412	5	0	1	0	1	-1.618	4	-1.589	5
265		3	max	11.84	2	0	1	1.438	4	0	1	1	0	1
266		min	7.539	1	-1.412	5	0	1	0	1	-1.079	4	-1.059	5
267		4	max	11.836	2	0	1	1.438	4	0	1	1	0	1
268		min	7.533	1	-1.412	5	0	1	0	1	-.539	4	-.53	5
269		5	max	11.831	2	0	1	1.438	4	0	1	4	0	5
270		min	7.528	1	-1.412	5	0	1	0	1	0	1	0	1

Envelope AISC 13th LRFD Steel Code Checks

Mem...	Shape	Code Check	Loc...	LC	Sh...	LC	Dir	LC	phi*P...	phi*Pnt...	phi*Mn y-y [k-ft]	phi*Mn z...	Cb	Egn
1	M1	W16X26	803	14...	2	.129	2...	y	2	202.3	248.832	14.796	119.34	1 H1..
2	M2	W16X26	496	14...	2	.095	0	y	2	202.3	248.832	14.796	119.34	1 H1..
3	M3	W10X15	125	5.891	2	.030	1...	y	2	39.824	142.884	6.21	28.637	1... H1..
4	M4	W10X15	119	4.89	2	.028	0	y	2	39.824	142.884	6.21	29.394	1... H1..
5	M5	W8X13	255	5.446	2	.061	1...	y	2	37.619	124.416	5.805	22.591	1... H1..
6	M6	W8X13	308	4.224	2	.090	0	y	2	37.619	124.416	5.805	22.834	1... H1..
7	M7	W8X13	301	2.779	5	.086	0	y	2	37.619	124.416	5.805	24.936	1... H1..
8	M8	W8X13	397	2.779	5	.111	0	y	4	37.619	124.416	5.805	25.622	1... H1..
9	M9	W8X13	378	2.779	4	.129	0	y	4	37.619	124.416	5.805	24.665	1... H1..
10	M10	W8X13	252	4.668	2	.063	0	y	2	37.619	124.416	5.805	23.49	1... H1..
11	M11	W8X13	010	1.5	1	.008	0	y	1	104.9	124.416	5.805	30.78	1... H1..
12	M12	W8X13	035	2.481	1	.017	4	y	1	101.8	124.416	5.805	30.78	1... H1..
13	M13	W8X13	027	1.001	1	.025	0	y	1	118.99	124.416	5.805	30.78	1... H1..
14	M14	W8X13	069	1.519	4	.062	4...	y	4	102.2	124.416	5.805	30.78	1... H1..
15	M15	W8X13	004	3.573	1	.008	4...	y	1	104.1	124.416	5.805	30.78	1... H1..
16	M16	W8X13	017	2.507	4	.014	4	y	4	101.4	124.416	5.805	30.78	1... H1..
17	M17	W8X13	018	1.5	5	.012	0	y	5	104.9	124.416	5.805	30.78	1... H1..
18	M18	W8X13	060	2.481	5	.028	4...	y	5	101.8	124.416	5.805	30.78	1... H1..
19	M19	W8X13	048	1.001	5	.040	0	y	5	118.99	124.416	5.805	30.78	1... H1..
20	M20	W8X13	113	1.519	5	.072	4	y	5	102.2	124.416	5.805	30.78	1... H1..
21	M21	W8X13	007	3.573	5	.015	4...	y	5	104.1	124.416	5.805	30.78	1... H1..
22	M22	W8X13	017	2.507	4	.014	4	y	4	101.4	124.416	5.805	30.78	1... H1..

Project: WA 659 Good Samaritan
 LDC #: 11-256 Date: 11/10/11 Engineer: PAO Page: 16 of 19

LDC

14201 NE 200th St., #100 • Woodinville, WA 98072 • ph: 425.806.1869 • fx: 425.482.2893

www.LDCcorp.com

Roof Beam

W21x44

From Velocity Codes $\phi M_n = 250 \text{ K-ft}$,

$$M_w = 221 \text{ K-ft}$$

$$R_1 = 1.25 \times 18.5 / 30.5 = 0.76 \text{ K}$$

$$R_2 = 1.25 - 0.76 = 0.49 \text{ K}$$

$$\therefore M = 0.76 \times 12 = 9.12 \text{ K-ft}$$

$$\therefore M_w = 221 + 9.12 = 230.1 \text{ K-ft}$$

$$230.1 < 250 \text{ OK}$$

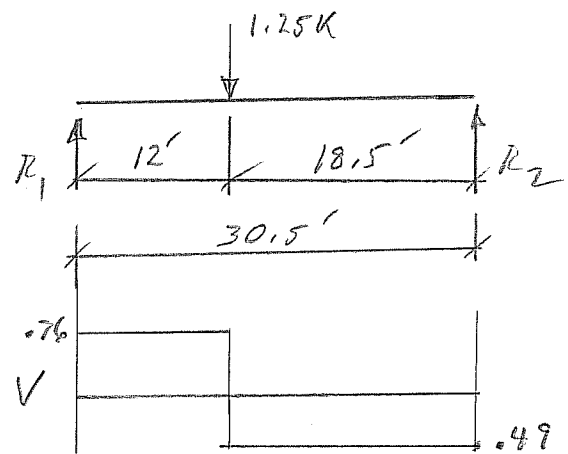

Note: The previous beam checks are very conservative because the moment from the cabinet is added to the worst case condition for the beam, but with the exception of the W21x44 Floor Beam, they do not occur at the same place

Client: AT&T
 Site Name: Good Samaritan
 Site Id: 10029581

570 Colonial Park Dr. Ste #307
 Roswell, GA 30075



Member Loads

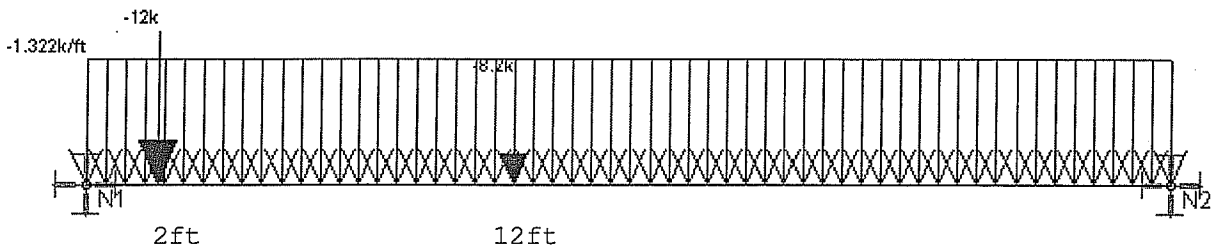

Member Moments

W21X44

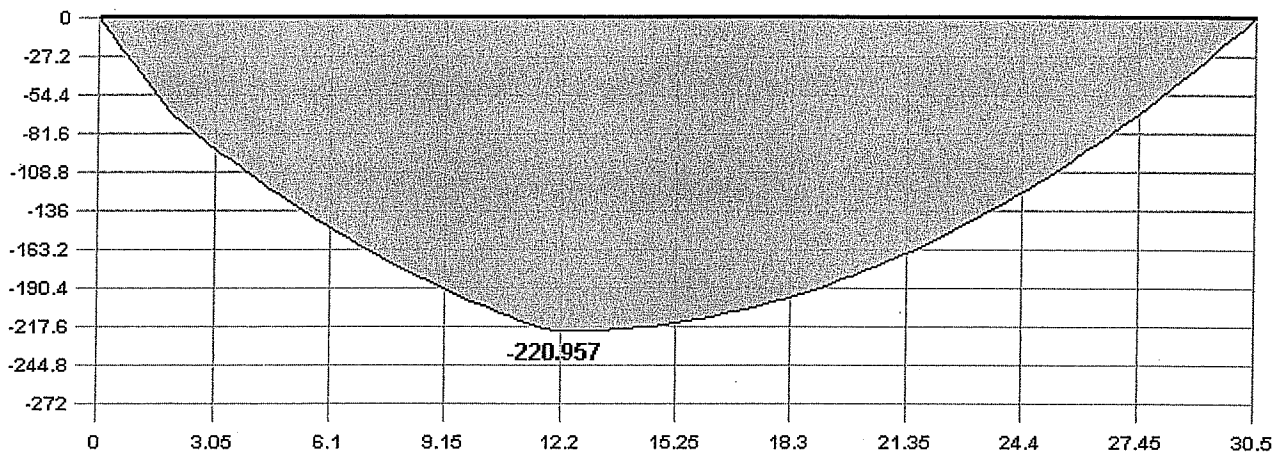

$M_u := 221 \text{ kip}\cdot\text{ft}$

$V_u := 36.3 \text{ kip}$

Fy	36 ksi	Y-Y	Z-Z
$\phi_i^*P_{nc}$	331.965 k	Lb	6 ft
$\phi_i^*P_{nt}$	421.2 k	KL/r	57.058
$\phi_i^*M_{ny}$	27.515 k-ft	Sway	No
$\phi_i^*M_{nz}$	250.232 k-ft	L Comp Flange	6 ft
$\phi_i^*V_{ny}$	156.19 k	Torque Length	30.5 ft
$\phi_i^*V_{nz}$	113.724 k		
Cb	1		

$\phi M_n := 250 \text{ kip}\cdot\text{ft} > M_u = 221 \text{ kip}\cdot\text{ft} \quad \text{OK}$

$\phi V_n := 113.7 \text{ kip} > V_u = 36.3 \text{ kip} \quad \text{OK}$

Therefore, the existing steel girders supporting the equipment platform have adequate capacity to support the additional loads due to the proposed new cabinet. Therefore, the proposed installation can be implemented as intended.

Project: WA 659 Food SanitationLDC #: 11-256 Date: 11/10/11 Engineer: DAO Page: 18 of 19

14201 NE 200th St., #100 • Woodinville, WA 98072 • ph: 425.806.1869 • fx: 425.482.2893

LDC

www.LDCcorp.com

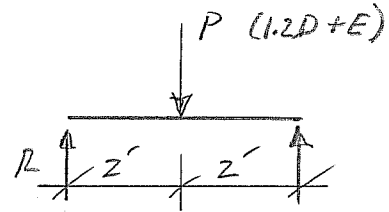
Purcell Cabinet Support BeamsTry C6X8.2 $F_y = 36 \text{ ksi}$ $P_u = 1737/2 = 868.5$ from previousSay $P_u = 1 \text{ K}$ (LRFD)

$$\therefore M = PL/4 = 1 \times 4/4 = 1 \text{ K-ft.}$$

From Analysis $\phi M_n = 12.66 \text{ K-ft.}$

$$12.66 > 1 \quad \underline{\text{OK}}$$

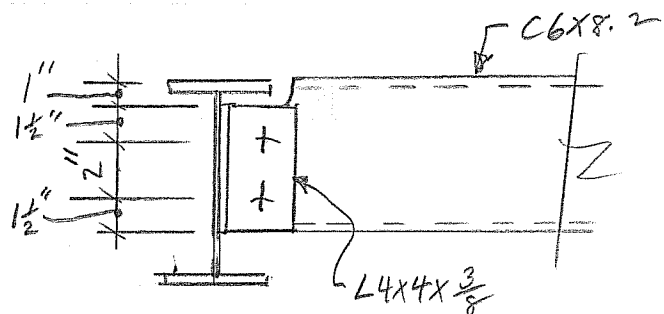
Use C6X8.2 support beamsBy inspection (2) $\frac{5}{8}$ " ϕ ASTM A325N bolts @ each end will be OK ($2 \times 7.36 = 14.72 \text{ K} > 1 \text{ K}$)An $L4 \times 4 \times \frac{3}{8} \times 0'-5"$ will be OK for clip angle thus:

WA659 Good Samaritan
 407 14th Ave SE Puyallup, WA 98372
 Project: 11-256

Page: 19
 Engineer: DAO
 Date: 11/10/2011



Strong Axis Bending Capacity
AISC 13 Strong Axis Bending of Channels and Wideflanges Per Sections F2 And F3

C6X8.2	$\Omega_b =$	1.67	$\Phi_b =$	0.9
---------------	--------------	------	------------	-----

d =	6.000 in	L =	4.00 ft (Span Length)
t _w =	0.200 in	L _b =	4.00 ft (Unbraced Length)
b _f =	1.920 in	C _b =	1.00 (Conservative)
t _f =	0.343 in	F _y =	36 ksi
k =	0.813 in	E =	29000 ksi
S _x =	4.350 in ³	M _{max} =	k-ft (AISC 13 Eqn F1-1)
Z _x =	5.160 in ³	M _A =	k-ft (AISC 13 Eqn F1-1)
I _y =	0.687 in ⁴	M _B =	k-ft (AISC 13 Eqn F1-1)
r _y =	0.536 in	M _C =	k-ft (AISC 13 Eqn F1-1)
J =	0.074 in ⁴	Result =	LRFD (LRFD or ASD)
C _w =	4.700 in ⁶		

Calculated Values

M _p =	185.76 k-in	Equation F2-1	Flange Compactness Check (AISC 13 B4.1-1) b _f /2t _f = 2.80 λ _p = 10.79 Compact Flange λ _r = 28.38 k _c = 0.76
M _p =	15.48 k-ft		
L _p =	26.77 in	Equation F2-5	
L _p =	2.23 ft		
h =	4.38 in		Web Compactness Check (AISC 13 B4.1-9) h/t _w = 21.88 λ _p = 106.72 Compact Web λ _r = 161.78
h ₀ =	5.66 in		
c =	1.08		
r _{ts} =	0.64 in	Equation F2-7	
L _r =	122.21 in	Equation F2-6	
L _r =	10.18 ft		

Yielding Moment:

M_n = 185.76 k-in Compact Flanges: Equation F2-1

Lateral-Torsional Buckling Moment:

F_{cr} = 79.62 ksi Equation F2-4
 M_n = 168.83 k-in Equation F2-2 <==== Controls

Results

M_c = 12.66 k-ft LRFD Maximum Moment
W = 6.33 k/ft LRFD Maximum Uniform Load



GENERAL DYNAMICS

Information Technology

Ms. Melissa Browning
General Dynamics Information Technology, Inc.
19240 Des Moines Memorial Drive South, Suite 300
SeaTac, WA 98148
(360) 485-7196

MORRISON HERSHFIELD

Morrison Hershfield
1455 Lincoln Parkway, Suite 500
Atlanta, GA 30346
(770) 379-8500

Date: December 5, 2019

Subject: Equipment Platform Structural Analysis Report

2020 equipment configuration showing
cabinets and platform screen.

AT&T Designation:

Site USID: 75153-A
Site FA: 10029581
Site Name: GOOD SAMARITAN

Site Address: 407 14th Avenue Southeast, Puyallup, Pierce County, WA 98371
Site Coordinates: Latitude: 47° 10' 46.2" N, Longitude: 122° 17' 26.009" W

Tower Description: 68' 1" ft – Building
Mount Description: Roof top Platform

Morrison Hershfield Project Number: GED-577R5 / 2000204

Dear Ms. Browning,

Morrison Hershfield is pleased to submit this “**Equipment Platform Structural Analysis Report**” to determine the structural integrity of existing equipment mounting system for the existing equipment on the above mentioned supporting building structure.

This mount analysis has been performed in accordance with the 2015 IBC based upon an ultimate 3-second gust wind speed of 115 mph. Exposure Category C with a maximum topographic factor, K_{zt} , of 1.0 and Risk Category IV were used in this analysis.

Our analysis demonstrates that the existing equipment platform **IS in conformance** with the requirements of the above noted standards under the effects of loading described.

Summary of Results		
Mount Components	84.3%	Sufficient

We at *Morrison Hershfield* appreciate the opportunity of providing our continuing professional services to you and General Dynamics Information Technology, Inc. If you have any questions or need further assistance on this or any other projects please give us a call.

Respectfully submitted by:
Morrison Hershfield

Shawn W. Stevenson, S.E. (WA License No. 42002)
Senior Engineer



INTRODUCTION

This is a 68' 1" ft tall building. Existing equipment are located on the roof top mounted platform, at the above building site.

ANALYSIS CRITERIA

The following design parameters have been used in our analysis:

Design Standard:	2015 International Building Code ASCE 7-10, Minimum Design Loads for Building and Other Structures AISC 325-11, Manual of Steel Construction ACI 318-11, Building Code Requirements for Structural Concrete
Design Wind Speed:	115 mph (Ultimate 3-sec gust)
Risk Category:	IV
Exposure Category:	C
Topographic Factor, K_{zt} :	1.0

The mount analysis was based on the following documentation:

Table 1 – Documentation

Document	Description	Source
Load Mapping Report	Morrison Hershfield, Site Name: GOOD SAMARITAN, dated 10/18/2019	MH
Previous Mount Analysis	Morrison Hershfield, Site Name: GOOD SAMARITAN, dated 11/08/2018	MH
Previous Platform Analysis	Smartlink, Site Name: GOOD SAMARITAN, dated 10/28/2015	Client
Previous Platform Analysis	Smartlink, Site Name: GOOD SAMARITAN, dated 02/09/2016	Client
As Built Drawings	Smartlink, Site Name: GOOD SAMARITAN, dated 09/09/2016	Client
Roof Framing Plan	Martens Consulting Engineers, Site Name: GOOD SAMARITAN HOSPITAL, dated 10/15/1999	Client
RF Design Sheet	AT&T, RFDS Name: COL01074_IIiff_&_I225, dated 4/2/2019	Client



1.0 ANALYSIS LOADING

The existing equipment considered in this analysis were provided by the client and are noted in Table 2.

Table 2 – Equipment Loads

Mounting Level (ft)	Existing Equipment Description	Note
67.5	(1) Argus TE43 Cabinet	1
	(2) Purcell FLX16WS Cabinet	
	(1) Argus TE41 Cabinet	
	(1) UMTS Cabinet	
	(1) Transformer	
	(1) Hoffman Box	
	(1) Surge Suppressor Box	
	(1) Telco Demarc	
	(1) AC Panel	

Note: Any discrepancies in loading from this listing should be brought to Morrison Hershfield's attention; results of this assessment cannot be used if the loading is different.

- Existing equipment.

ANALYSIS PROCEDURE

RISA-3D (version 17.0.4), a commercially available analysis software package, was used to create a three-dimensional model of the antenna mounting system and calculate member stresses for various loading cases.

2.0 ASSUMPTIONS

- The antenna mounting system was properly fabricated, installed and maintained in good condition in accordance with its original design and/or manufacturer's specifications.
- The configuration of antennas, mounts, and other appurtenances are as specified.
- All member connections are assumed to have been designed to meet or exceed the load carrying capacity of the connected members unless otherwise specified in this report.
- This analysis assumes the screen wall system and its connection to the building structure to have been designed to meet or exceed the current wind loading requirements.
- The analysis will be required to be revised if the existing conditions in the field differ from those shown in the above-referenced documents or assumed in this analysis. No allowance was made for any damaged, missing, or rusted members.
- Steel grades have been assumed as follows, unless noted otherwise:

Channel, Solid Round, Angle, Plate	ASTM A36 (GR 36)
HSS (Rectangular)	ASTM 500 (GR B-46)
Pipe	ASTM A53 (GR 35)
- The existing platform geometry and member sizes are taken from the previous platform structural analysis by Smartlink, Site Name: GOOD SAMARITAN, dated 02/09/2016 and is considered to be correct.
- The equipment loading is taken from load mapping report prepared by Morrison Hershfield, Site Name: GOOD SAMARITAN, dated 10/18/2019, and are considered to be correct.

This analysis may be affected if any assumptions are not valid or have been made in error. Morrison Hershfield should be notified to determine the effect on the structural integrity of the antenna mounting system.



3.0 SUMMARY OF RESULTS

The following tables summarize the location and utilized percentage of available capacity for each component of the mount. With consideration to the appropriate safety factors, 100% represents the full capacity of the component. Percentages below 100% indicate available capacity and conformance of the component. Percentages between 100% and 105% indicate an acceptable capacity. Percentages above 105% indicate an overstressed situation requiring structural modification to ensure conformance with the applicable codes and standards.

A full seismic analysis has been performed in accordance with ASCE 7-10. However, the results due to seismic analysis are not controlling; the analysis results due to wind loading are controlling for the overall capacity.

Based on our analysis results, the existing roof top platform **ARE within capacity** to support the loads under the current loading scenario.

Mount Component Stresses vs. Capacity (Roof top Platform)

Component	Critical Member	% Capacity	Pass / Fail
Platform Support	M25	84.3	Pass
Platform Perimeter Beam (N and S)	M22	8.0	Pass
Platform Perimeter Beam (E and W)	M23	1.7	Pass
Secondary Framing	M3	27.9	Pass
Support Framing	M41	3.5	Pass

Structure Rating (max from all components) =	84.3%
---	--------------

4.0 RECOMMENDATIONS

The existing platform have sufficient capacity to support the equipment loads. No modifications are required at this time.

ATTACHMENTS: Software Input Calculations, Wire Frame and Rendered Models, Software Analysis Output & ASCE hazard tool report



Stealth Enclosed Platform:



Weight of Stealth Screen Enclosure = **28plf (from previous analysis)**

Weight of Equipment:

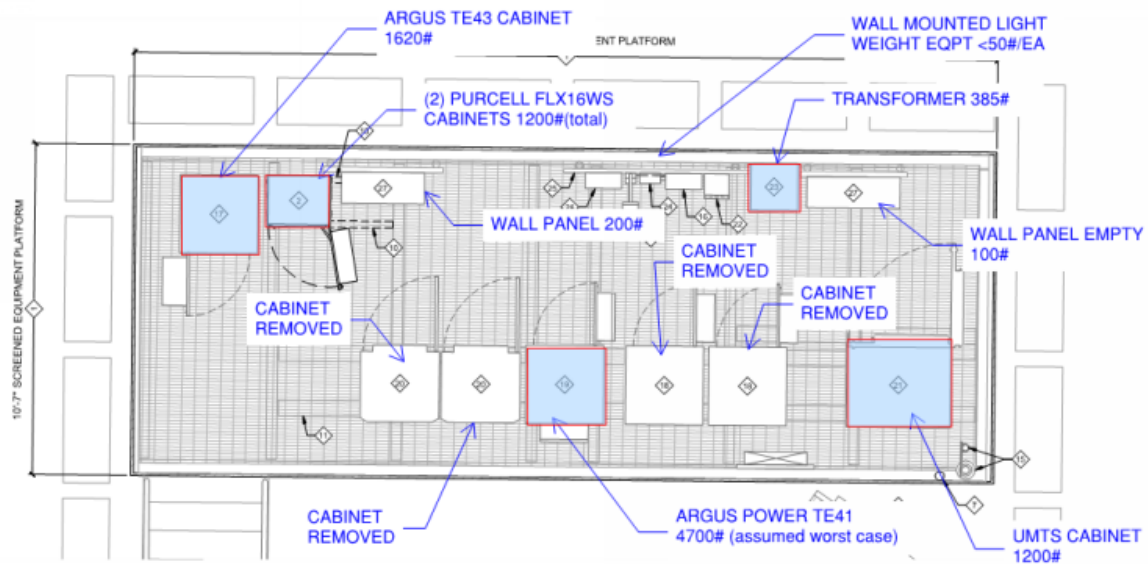

AT&T PLATFORM MAP



WIND LOAD CALCULATIONS ON APPURTENANCES AND MOUNTS:

Code Search

Code:

Occupancy:

Occupancy Group = Business

Risk Category & Importance Factors:

Risk Category:

Wind Loads - Other Structures: ASCE 7- 10

Ultimate Wind Pressures

Wind Factor = 1.00
 Gust Effect Factor (G) = 0.85 Ultimate Wind Speed = 115 mph
 Kzt = 1.00 Exposure = C

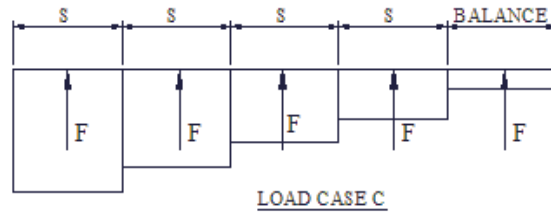
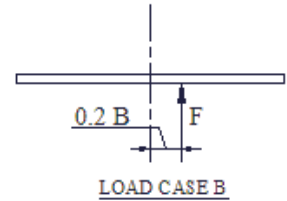
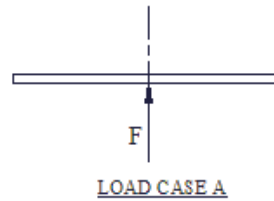
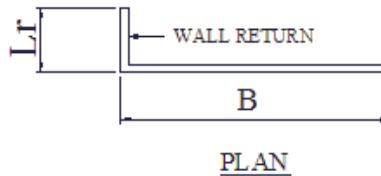
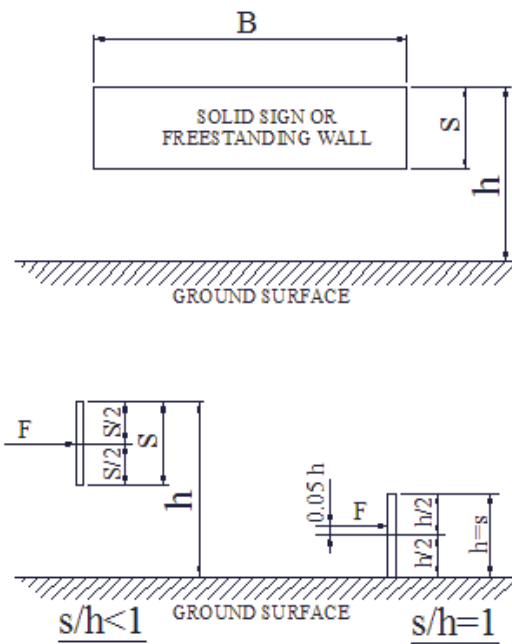

Front:

A. Solid Freestanding Walls & Solid Signs (& open signs with less than 30% open)

Dist to sign top (h)	73.5 ft	s/h =	0.08	Case A & B
Height (s)	6.0 ft	B/s =	4.61	C _r = 1.85
Width (B)	27.7 ft	Lr/s =	0.00	F = qz G C _f A _s = 53.7 As
Wall Return (Lr) =		Kz =	1.186	A _s = 166.2 sf
Directionality (Kd)	0.85	qz =	34.1 psf	F = 8921 lbs
Percent of open area to gross area	0.0%	ASCE7 Load Combinations Used		
		Open reduction factor =	1.00	CaseC
				Horiz dist from windward edge
		Case C reduction factors		C _f F=qzGC _f A _s (psf)
		Factor if s/h>0.8 =	1.00	0 to s 3.02 87.7 As
		Wall return factor		s to 2s 1.96 56.9 As
		for C _f at 0 to s =	1.00	2s to 3s 1.39 40.4 As
				3s to 10s 1.07 31.0 As

Side:

A. Solid Freestanding Walls & Solid Signs (& open signs with less than 30% open)

Dist to sign top (h)	73.5 ft	s/h =	0.08	Case A & B
Height (s)	6.0 ft	B/s =	1.75	C _r = 1.80
Width (B)	10.5 ft	Lr/s =	0.00	F = qz G C _f A _s = 52.2 As
Wall Return (Lr) =		Kz =	1.186	A _s = 63.0 sf
Directionality (Kd)	0.85	qz =	34.1 psf	F = 3290 lbs
Percent of open area to gross area	0.0%	ASCE7 Load Combinations Used		
		Open reduction factor =	1.00	CaseC
				Horiz dist from windward edge
		Case C reduction factors		C _f F=qzGC _f A _s (psf)
		Factor if s/h>0.8 =	1.00	0 to s 2.25 65.3 As
		Wall return factor		s to 2s 1.50 43.5 As
		for C _f at 0 to s =	1.00	



Front Face:

Load Case A: Applying the wind force on the front face 8921 lb directly at the centre

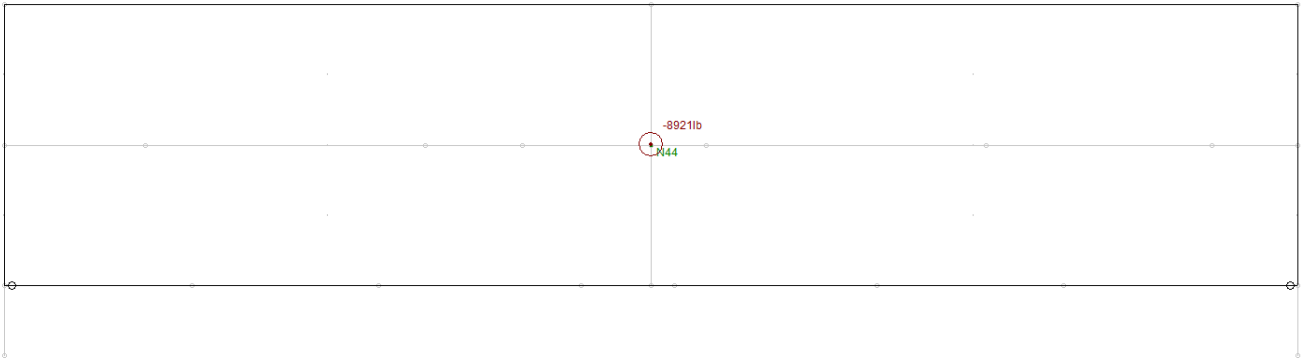

Load Case B:

Applying the wind force calculated on the front face 8921 lb at the 0.2 x length of the face = 0.2 x 166 = 33.2 in

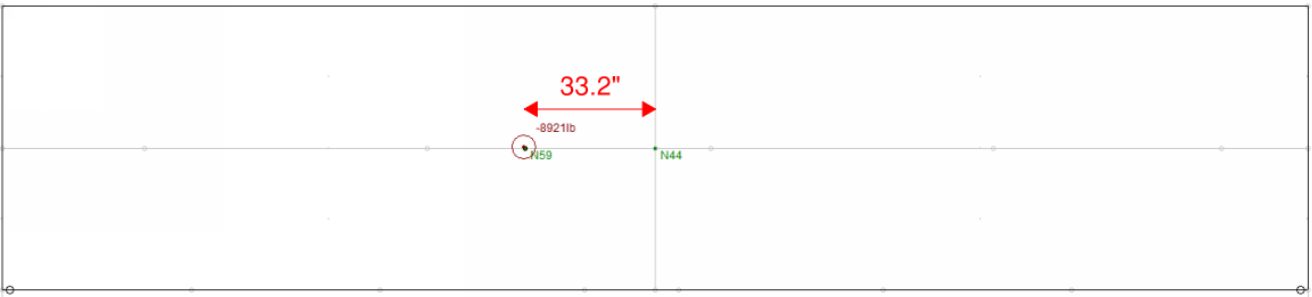

Load Case B:

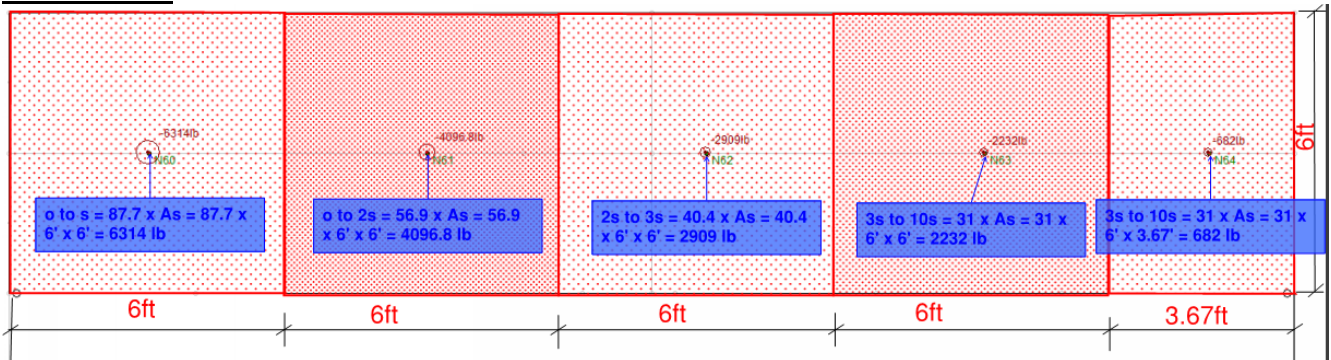

Side Face:

Load Case A: Applying the wind force on the side face 3290 lb directly at the centre

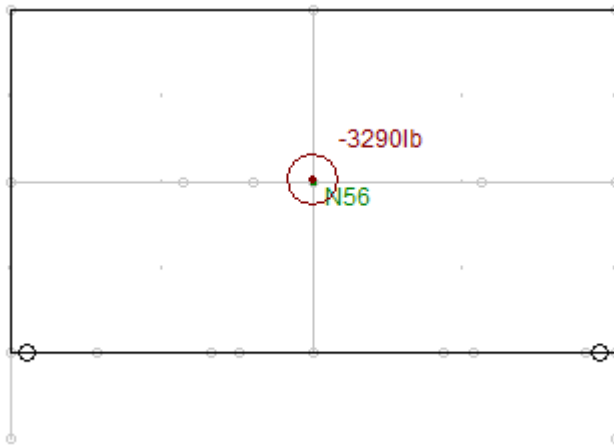

Load Case B:

Applying the wind force calculated on the front face 3290 lb at the 0.2 x length of the face = 0.2 x 63.5 = 12.7 in

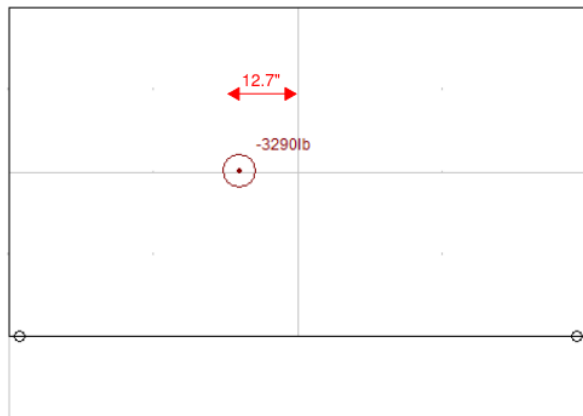

Load Case B:

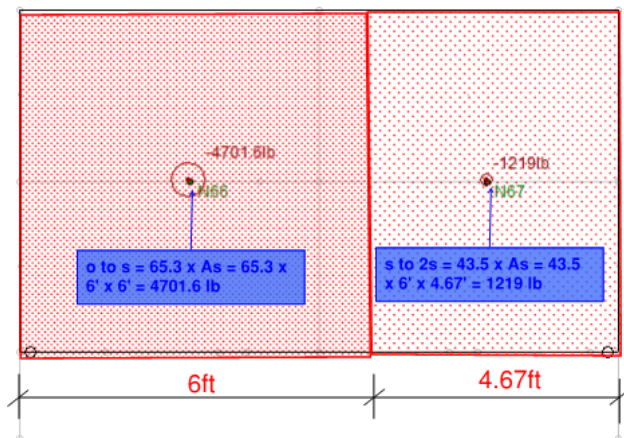

SEISMIC LOAD CALCULATIONS ON APPURTENANCES AND MOUNTS:

Per Table 15.4-1, ASCE 7-10 for Steel storage racks,
 Response modification coefficient, $R = 4.0$
 Overstrength factor, $\Omega = 2.0$

Per Table 13.6-1, ASCE 7-10 for generators, batteries and other electrical equipment
 Component amplification factor, $a_p = 1.0$
 Component response modification factor, $R_p = 2.5$

Seismic Loads: IBC 2015 Strength Level Forces

Risk Category : IV
 Importance Factor (I) : 1.50
 Site Class : **D** Class D

S_s (0.2 sec) = **125.00 %g**
 S_1 (1.0 sec) = **48.00 %g**

$F_a = 1.000$	$S_{ms} = 1.250$	$S_{DS} = 0.833$	Design Category = D
$F_v = 1.520$	$S_{m1} = 0.730$	$S_{D1} = 0.486$	Design Category = D

MECH AND ELEC COMPONENTS SEISMIC COEFFICIENTS

Mech or Electrical Component : Generators, batteries, inverters, motors, transformers, and other electrical components

Importance Factor (I_p) : Ip = 1.5 Life safety component required to function after an earthquake (e.g. fire protection sprinkler s

Component Amplification Factor (a_p) = 1 $h = 64.7$ feet
 Comp Response Modification Factor (R_p) = 2.5 $z = 67.5$ feet $z/h = 1.00$

$F_p = 0.4 a_p S_{ds} I_p W_p (1 + 2z/h) / R_p = 0.600 W_p$
 not greater than $F_p = 1.6 S_{ds} I_p W_p = 2.000 W_p$
 but not less than $F_p = 0.3 S_{ds} I_p W_p = 0.375 W_p$ use $F_p = 0.600 W_p$

Cabinets	Wp (lbs)	Seismic Design force ($F_p = 0.600 W_p$ lbs)
ARGUS TE43 Cabinet	1620	972
Purcell FLX16WS Cabinet	1200	720
Argus TE41 Cabinet	4700	2820
UMTS Cabinet	1200	720



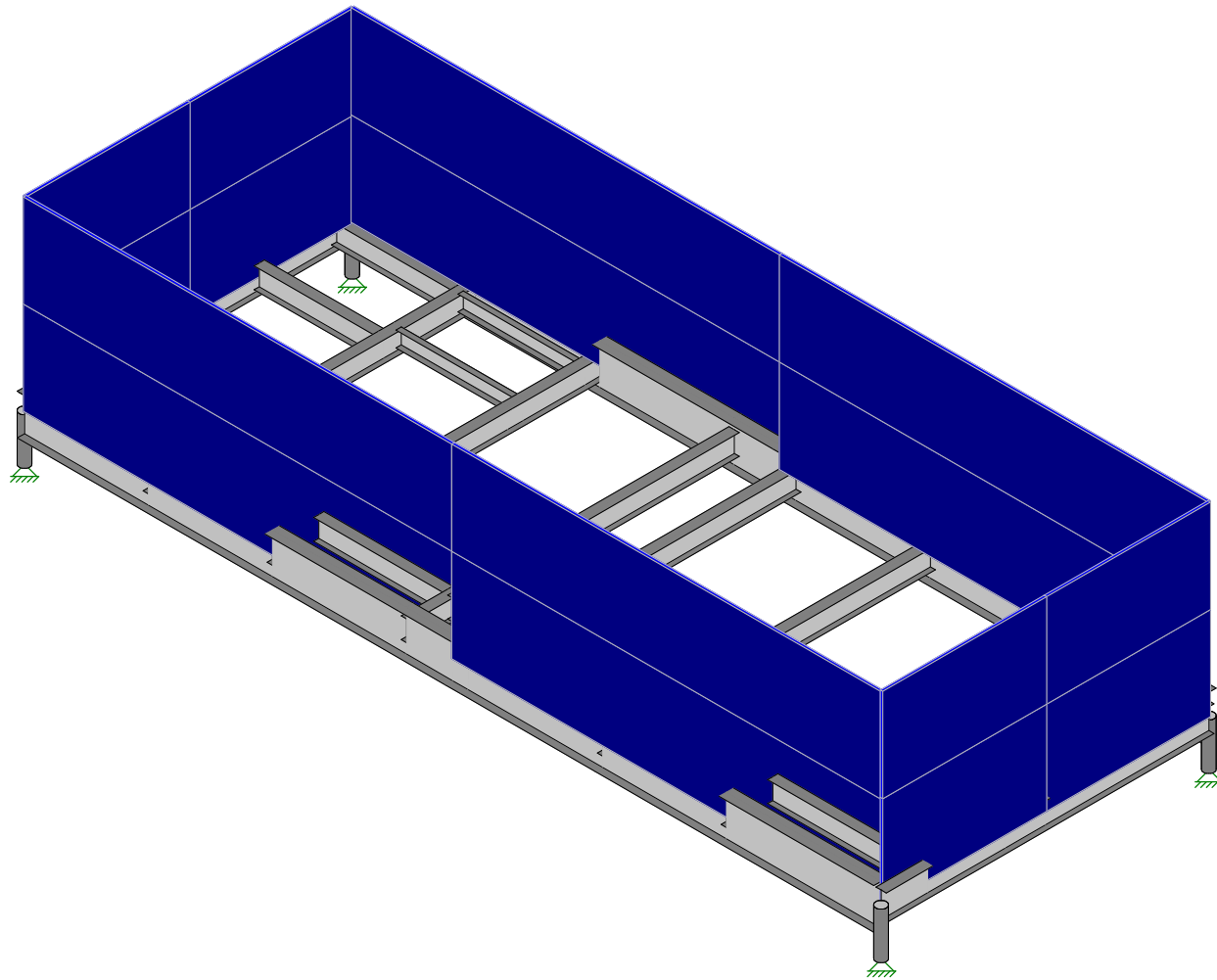
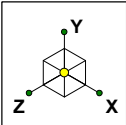

Envelope Only Solution

Morrison Hershfield
ML
GED-577R5 / 2000204

75153-A /GOOD SAMARITAN

SK - 2
Dec 5, 2019 at 2:34 PM
Platform Analysis.r3d

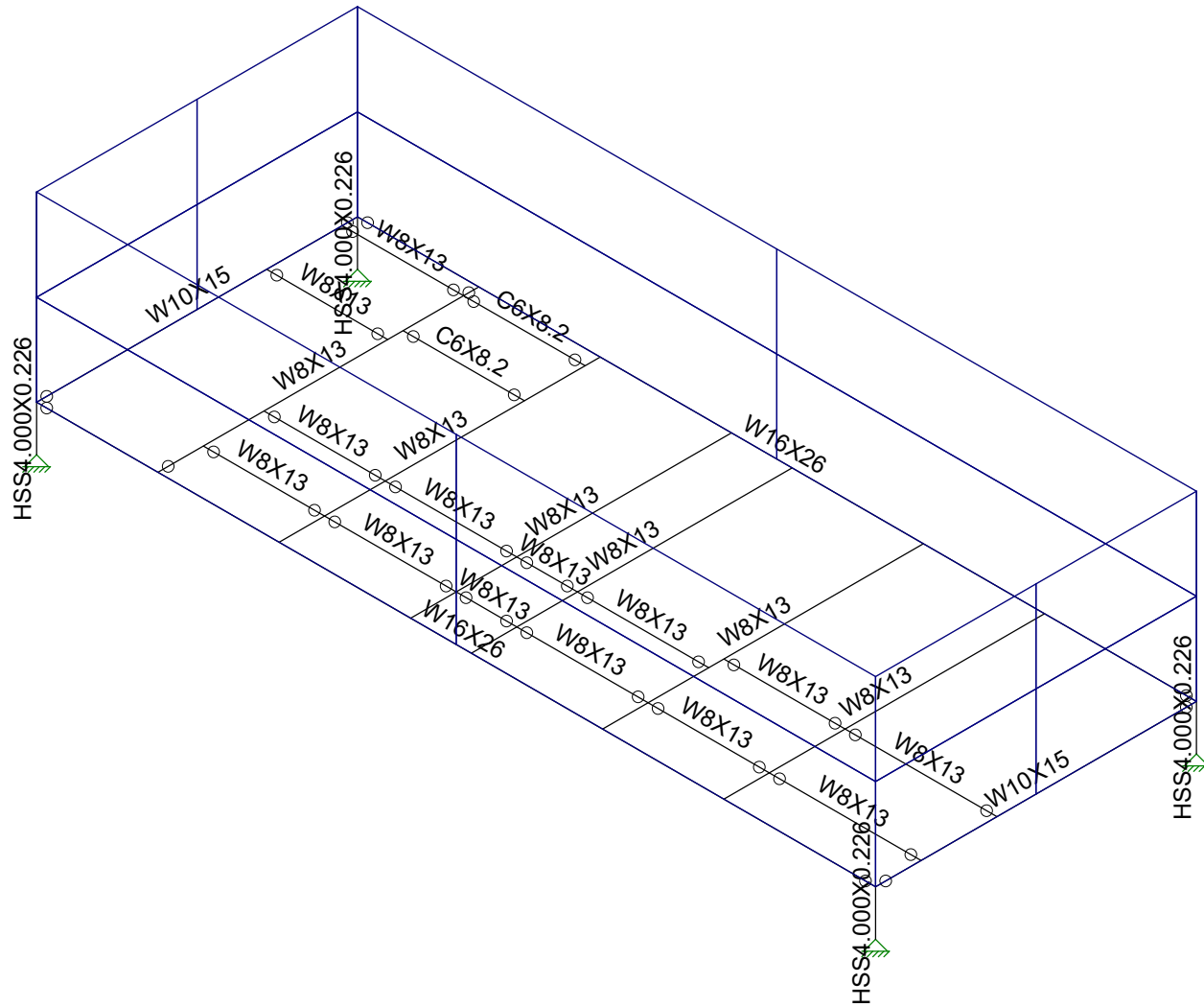
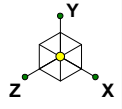

Envelope Only Solution

Morrison Hershfield

ML

GED-577R5 / 2000204

75153-A /GOOD SAMARITAN

SK - 4

Dec 5, 2019 at 2:36 PM

Platform Analysis.r3d

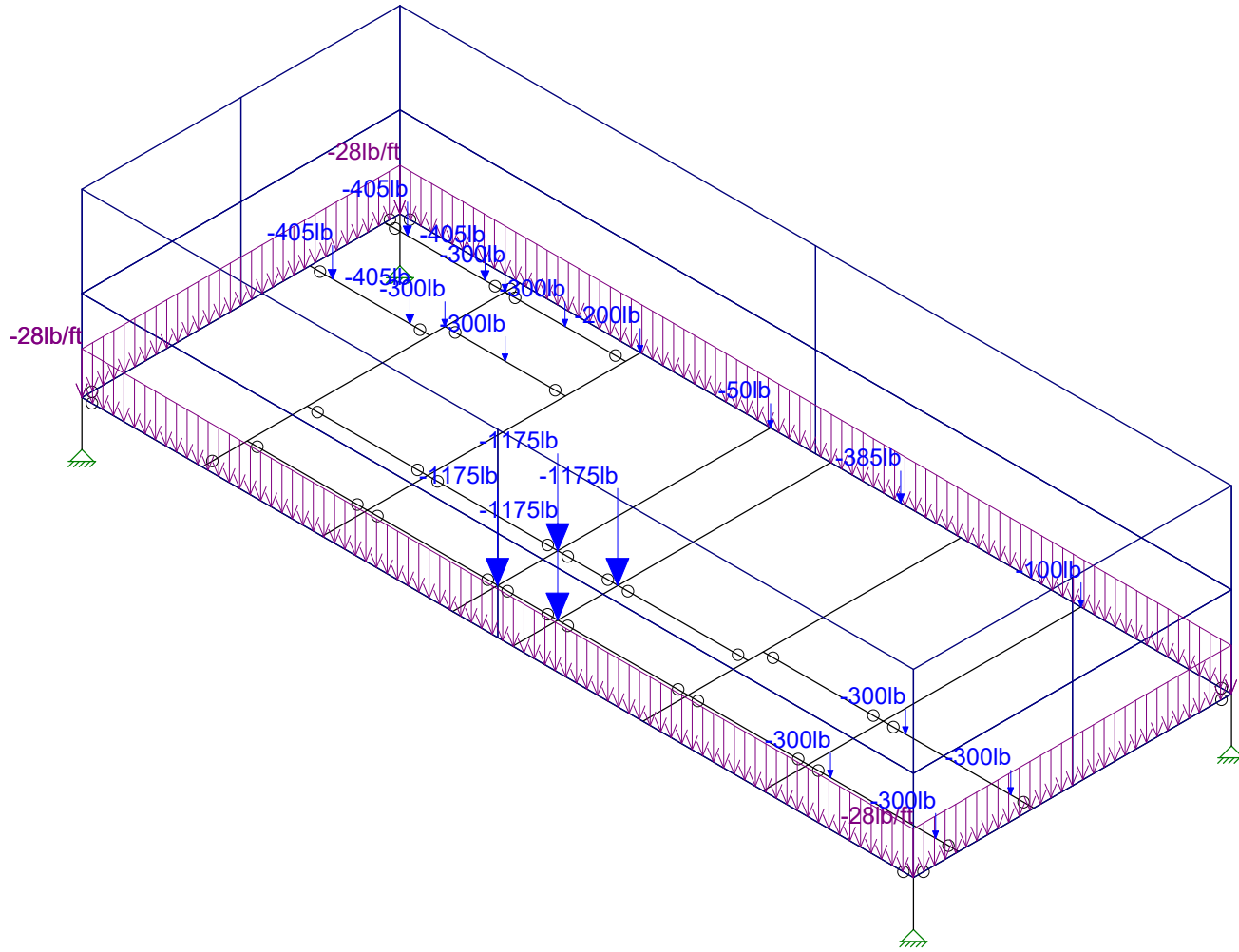
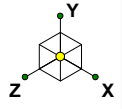

Loads: BLC 1, Dead Load
Envelope Only Solution

Morrison Hershfield	75153-A /GOOD SAMARITAN	SK - 3
ML		Dec 5, 2019 at 2:35 PM
GED-577R5 / 2000204		Platform Analysis.r3d

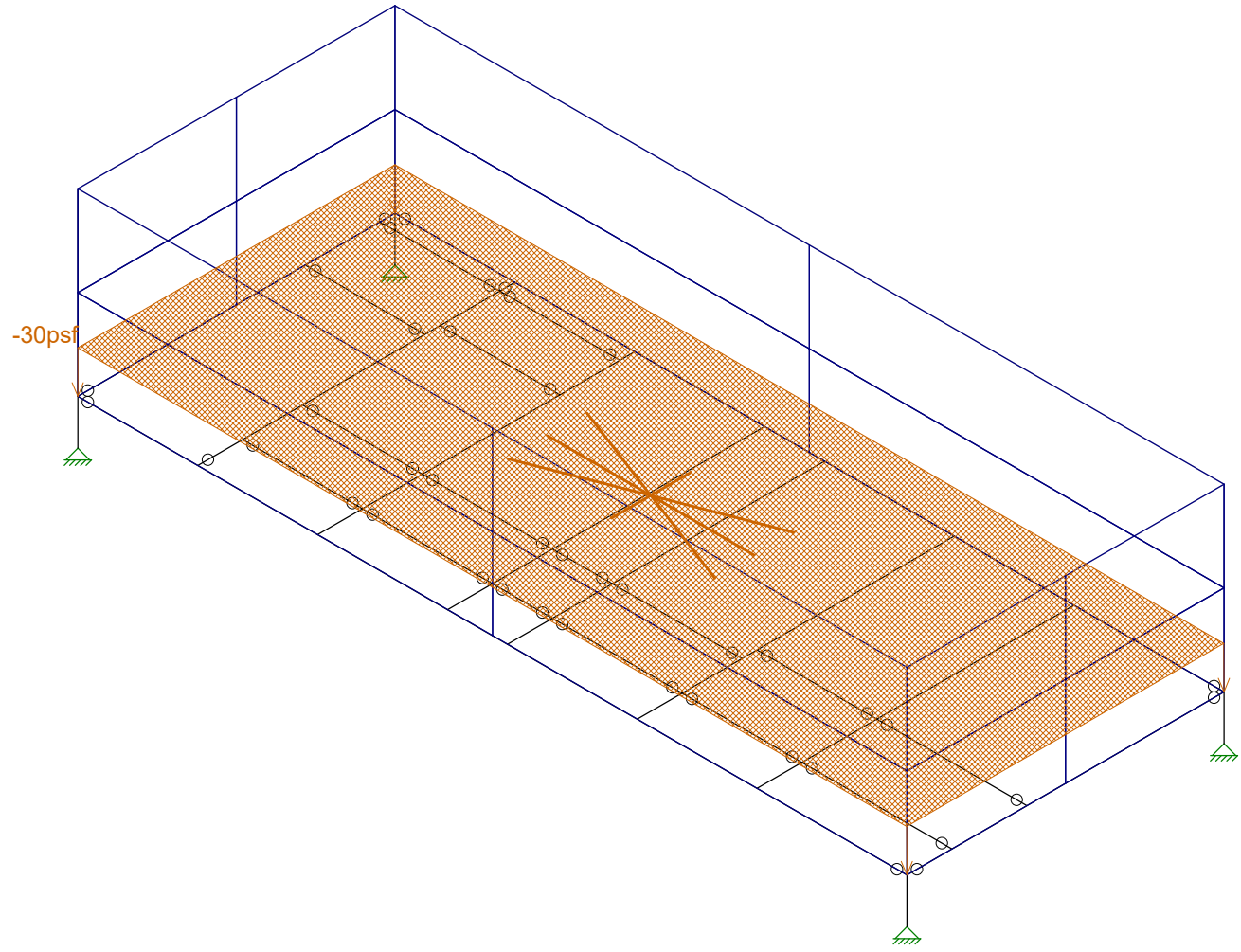
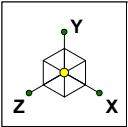

Loads: BLC 8, Snow Load
Envelope Only Solution

Morrison Hershfield
ML
GED-577R5 / 2000204

75153-A /GOOD SAMARITAN

SK - 5
Dec 5, 2019 at 2:36 PM
Platform Analysis.r3d

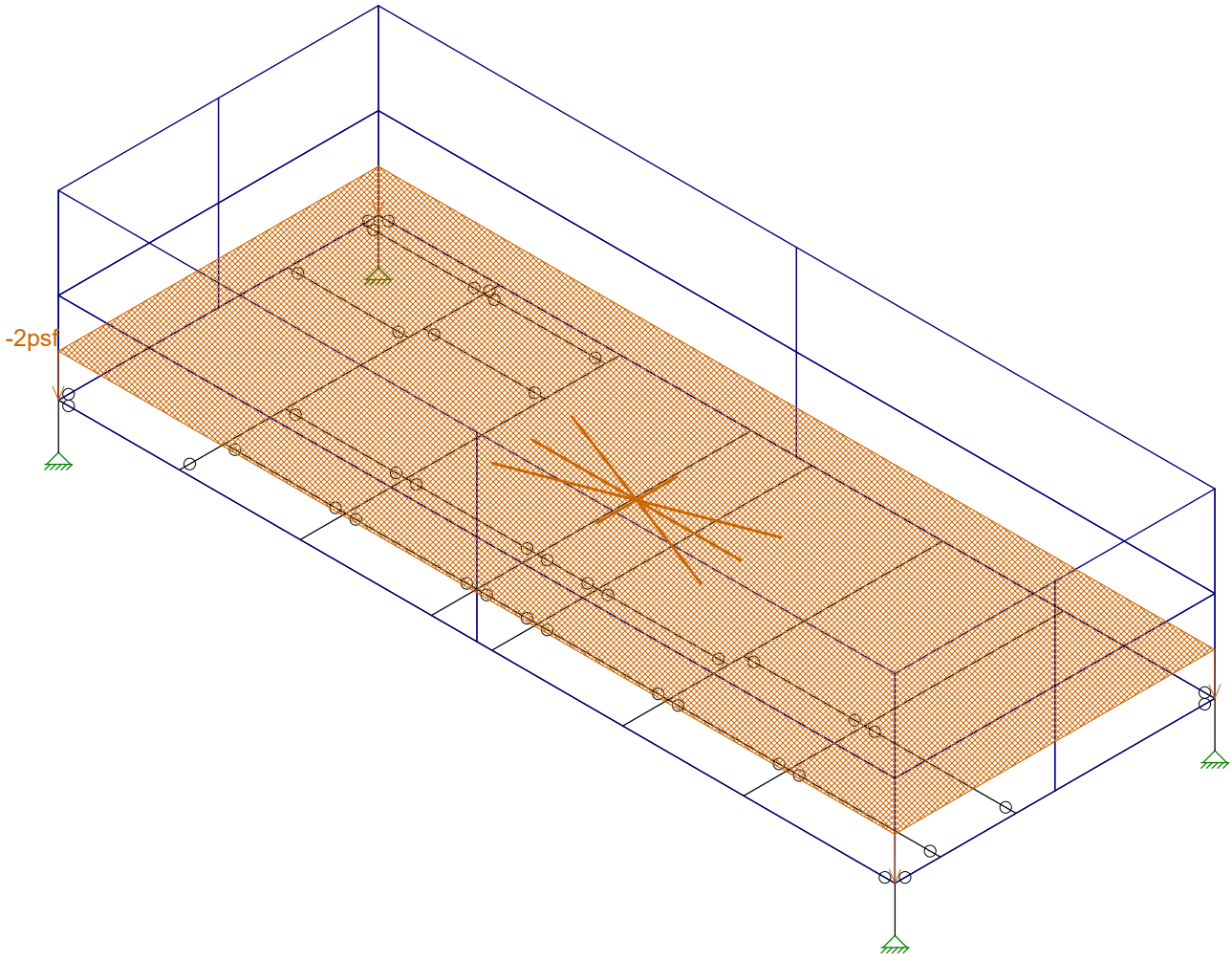
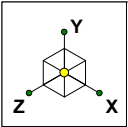

Loads: BLC 9, Weight Of aluminum grating
Envelope Only Solution

Morrison Hershfield
ML
GED-577R5 / 2000204

75153-A /GOOD SAMARITAN

SK - 6
Dec 5, 2019 at 2:37 PM
Platform Analysis.r3d

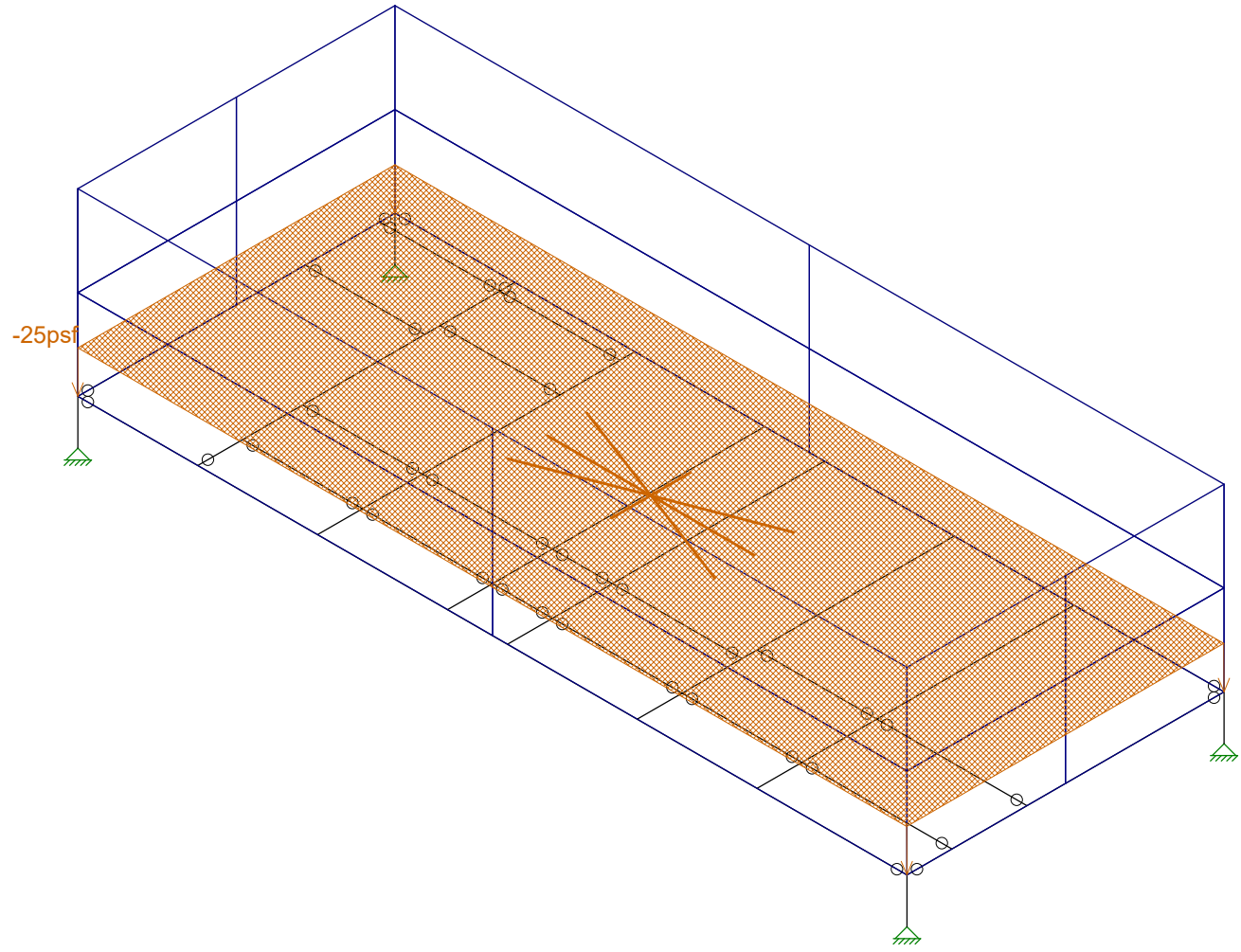
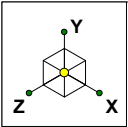

Loads: BLC 10, Live Load
Envelope Only Solution

Morrison Hershfield
ML
GED-577R5 / 2000204

75153-A /GOOD SAMARITAN

SK - 7
Dec 5, 2019 at 2:37 PM
Platform Analysis.r3d

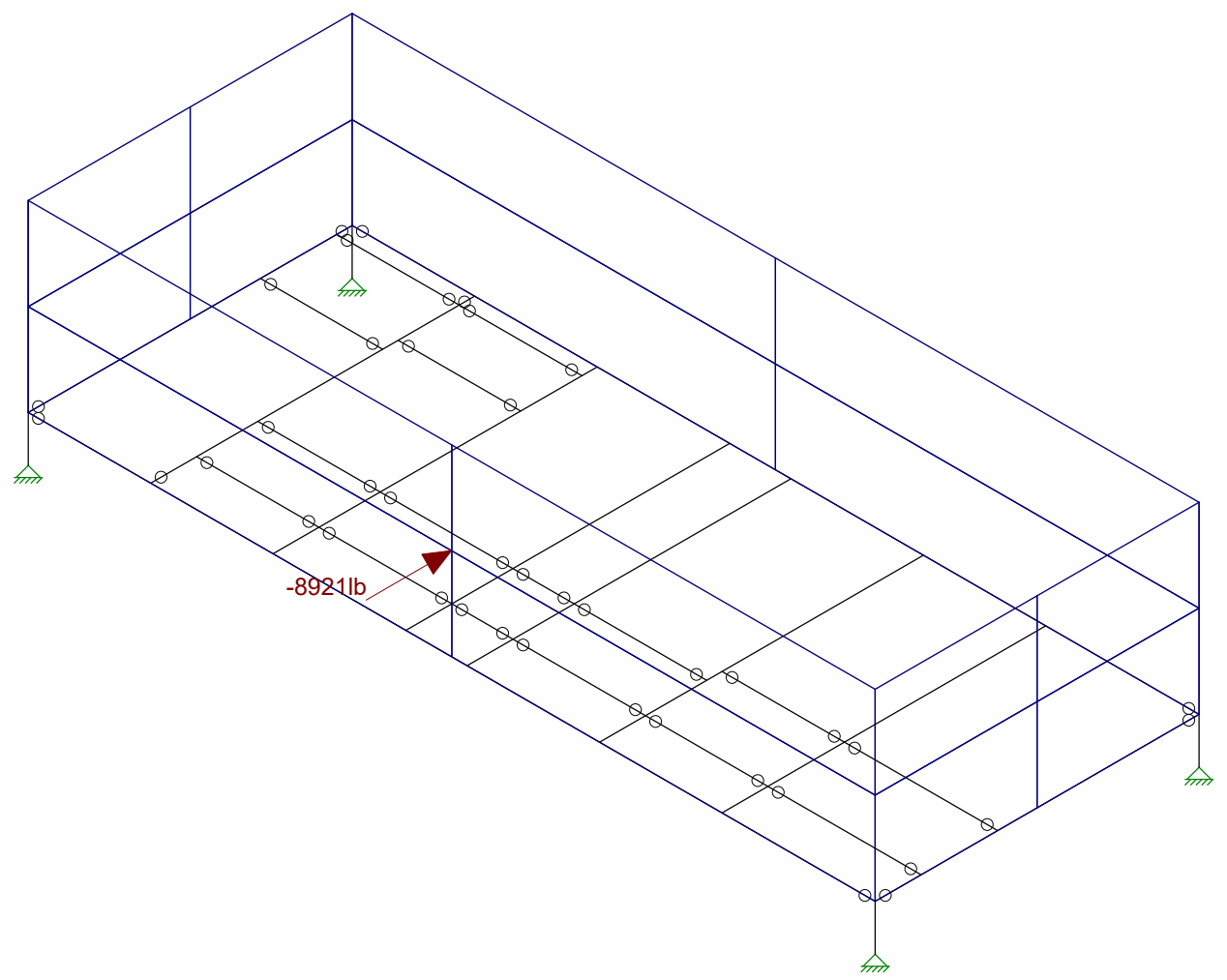
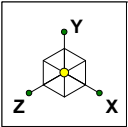

Loads: BLC 2, LCA Z
Envelope Only Solution

Morrison Hershfield
ML
GED-577R5 / 2000204

75153-A /GOOD SAMARITAN

SK - 8
Dec 5, 2019 at 2:37 PM
Platform Analysis.r3d

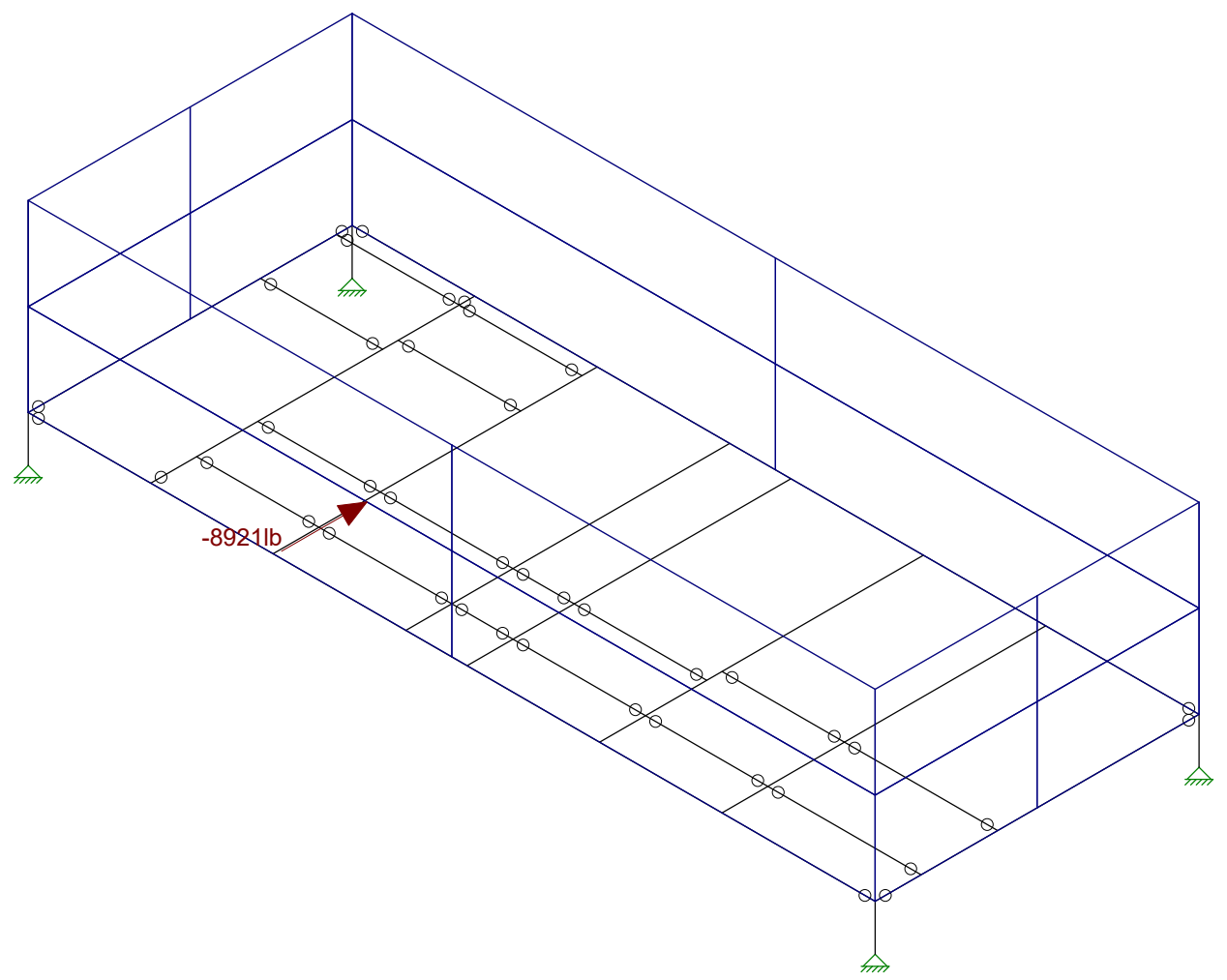
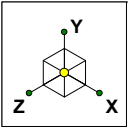

Loads: BLC 3, LCB Z
Envelope Only Solution

Morrison Hershfield	75153-A /GOOD SAMARITAN	SK - 9
ML		Dec 5, 2019 at 2:37 PM
GED-577R5 / 2000204		Platform Analysis.r3d

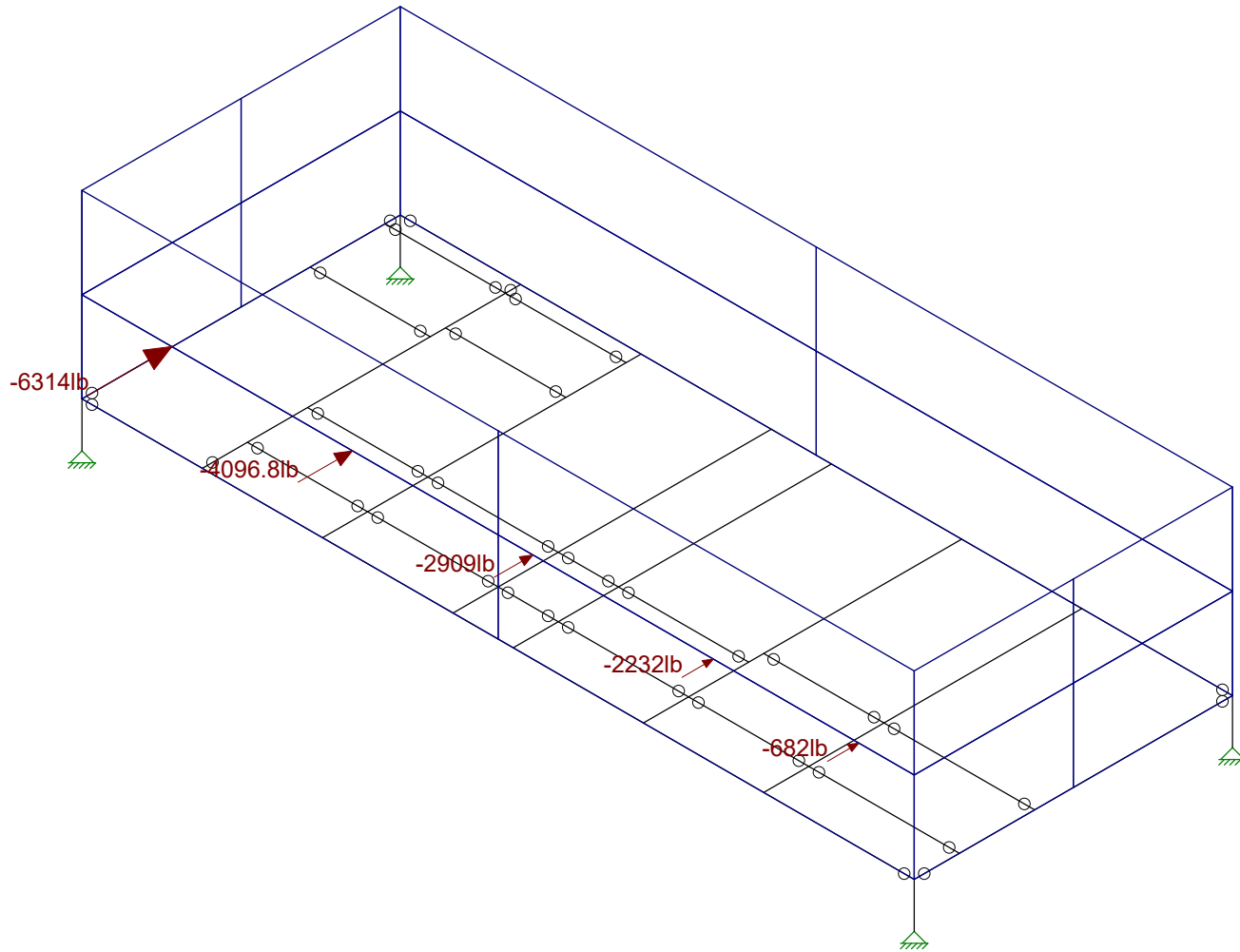
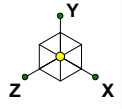

Loads: BLC 4, LCC Z
Envelope Only Solution

Morrison Hershfield
ML
GED-577R5 / 2000204

75153-A /GOOD SAMARITAN

SK - 10
Dec 5, 2019 at 2:38 PM
Platform Analysis.r3d

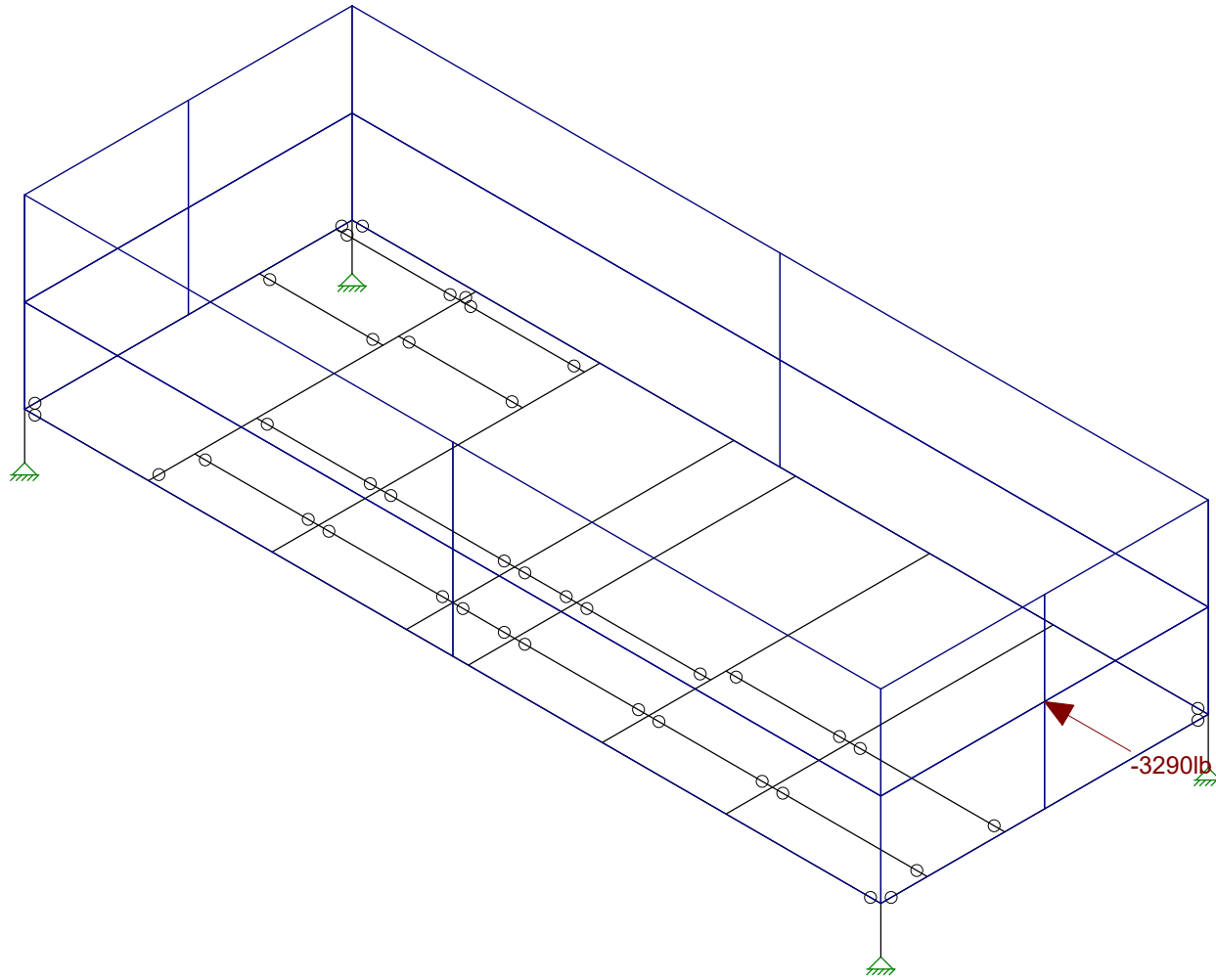
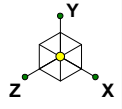

Loads: BLC 5, LCA X
Envelope Only Solution

Morrison Hershfield
ML
GED-577R5 / 2000204

75153-A /GOOD SAMARITAN

SK - 11
Dec 5, 2019 at 2:38 PM
Platform Analysis.r3d

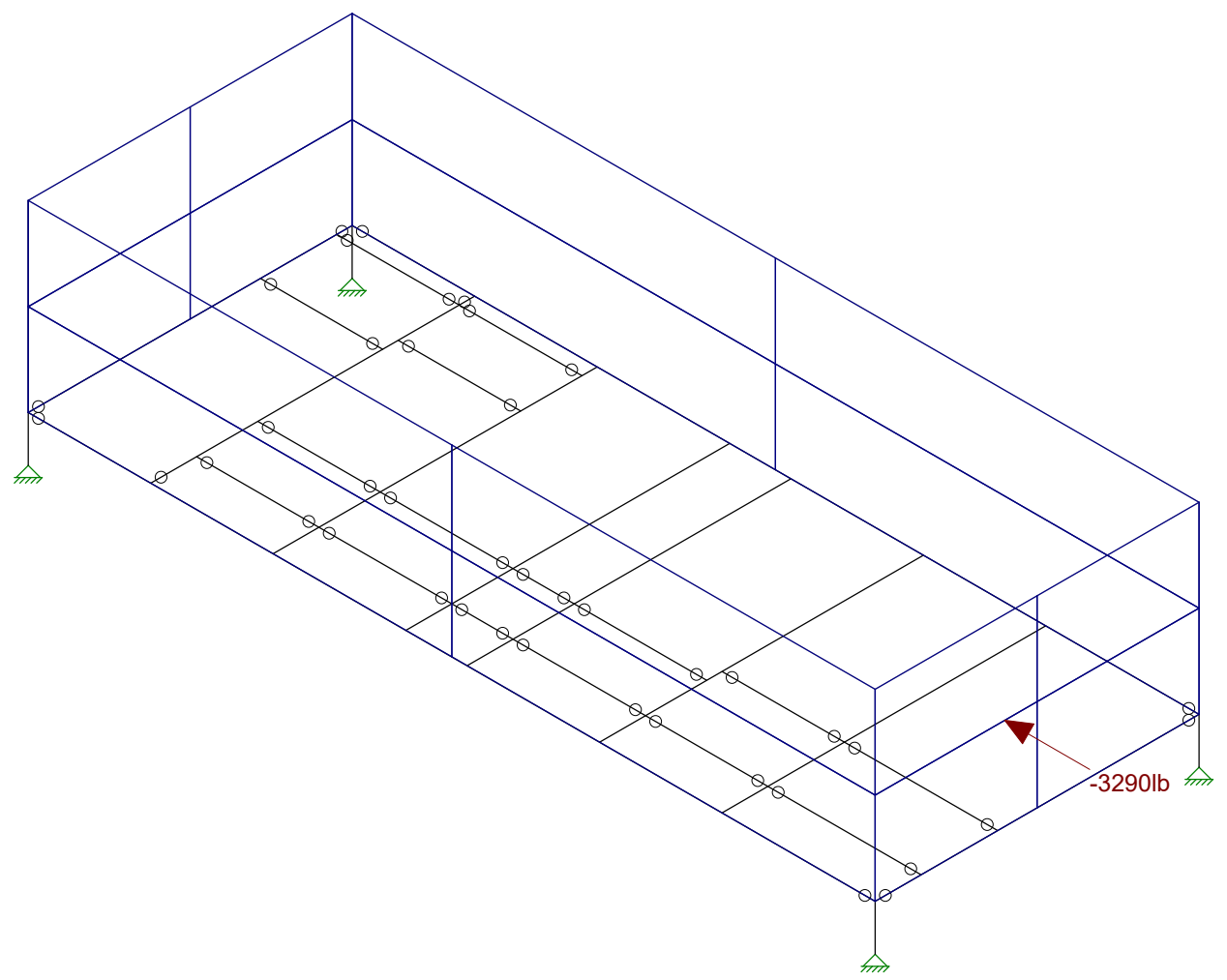
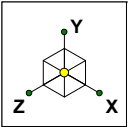

Loads: BLC 6, LCB X
Envelope Only Solution

Morrison Hershfield
ML
GED-577R5 / 2000204

75153-A /GOOD SAMARITAN

SK - 12
Dec 5, 2019 at 2:38 PM
Platform Analysis.r3d

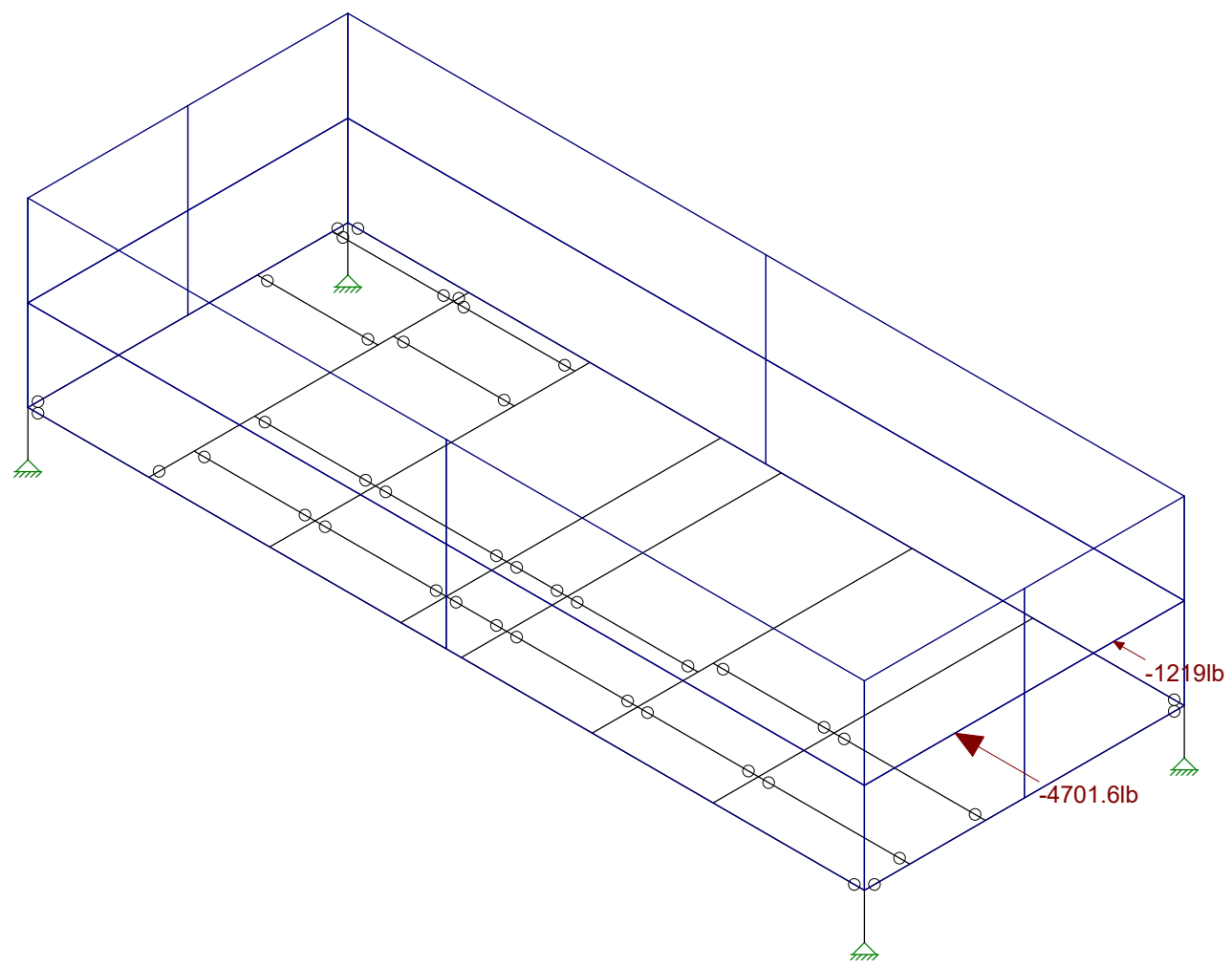
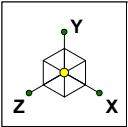

Loads: BLC 7, LCC X
Envelope Only Solution

Morrison Hershfield
ML
GED-577R5 / 2000204

75153-A /GOOD SAMARITAN

SK - 13
Dec 5, 2019 at 2:39 PM
Platform Analysis.r3d



Company : Morrison Hershfield
 Designer : ML
 Job Number : GED-577R5 / 2000204
 Model Name : 75153-A /GOOD SAMARITAN

Dec 5, 2019
 2:39 PM
 Checked By: SWS

Hot Rolled Steel Properties

	Label	E [ksi]	G [ksi]	Nu	Therm (/...	Density[k/ft^3]	Yield[ksi]	Ry	Fu[ksi]	Rt
1	A53 Gr.B	29000	11154	.3	.65	.49	35	1.6	60	1.2
2	A36 Gr.36	29000	11154	.3	.65	.49	36	1.5	58	1.2
3	A500 Gr.B Rect	29000	11154	.3	.65	.53	46	1.4	58	1.3
4	A500 Gr.B RND	29000	11154	.3	.65	.53	42	1.4	58	1.3
5	A992	29000	11154	.3	.65	.49	50	1.1	65	1.1

Hot Rolled Steel Section Sets

	Label	Shape	Type	Design List	Material	Desig...	A [in2]	Iyy [in..	Izz [i...	J [in4]
1	Platform Support	HSS4.000X0.2...	Column	HSS Pipe	A500 Gr.B RND	Typical	2.5	4.5	4.5	9.01
2	Platform Perimeter Beam (N and...	W16X26	Beam	Wide Flange	A992	Typical	7.68	9.59	301	.26
3	Platform Perimeter Beam (E and...	W10X15	Beam	Wide Flange	A992	Typical	4.41	2.89	68.9	.1
4	Secondary Framing	W8X13	Beam	Wide Flange	A992	Typical	3.84	2.73	39.6	.09
5	Support Framing	C6X8.2	Beam	Channel	A992	Typical	2.39	.69	13.1	.07

Joint Boundary Conditions

	Joint Label	X [k/in]	Y [k/in]	Z [k/in]	X Rot.[k-ft/rad]	Y Rot.[k-ft/rad]	Z Rot.[k-ft/rad]
1	N5	Reaction	Reaction	Reaction			
2	N7	Reaction	Reaction	Reaction			
3	N6	Reaction	Reaction	Reaction			
4	N8	Reaction	Reaction	Reaction			

Basic Load Cases

	BLC Description	Category	X Gravity	Y Gravity	Z Gravity	Joint	Point	Distribu...	Area(M...	Surface...
1	Dead Load	DL		-1			20	4		
2	LCA Z	OL1				1				
3	LCB Z	OL2				1				
4	LCC Z	OL3				5				
5	LCA X	OL4				1				
6	LCB X	OL5				1				
7	LCC X	OL6				2				
8	Snow Load	SL							1	
9	Weight Of aluminum gr...	DL							1	
10	Live Load	LL							1	
11	BLC 9 Transient Area ...	None						132		
12	BLC 10 Transient Area...	None						132		
13	BLC 8 Transient Area ...	None						132		

Member Point Loads (BLC 1 : Dead Load)

	Member Label	Direction	Magnitude[lb.lb-ft]	Location[in. %]
1	M17	Y	-300	9
2	M19	Y	-300	9
3	M17	Y	-300	51
4	M19	Y	-300	51
5	M13	Y	-1175	0
6	M12	Y	-1175	0
7	M13	Y	-1175	%100
8	M12	Y	-1175	%100
9	M7	Y	-405	9
10	M20	Y	-405	9
11	M7	Y	-405	40



Company : Morrison Hershfield
 Designer : ML
 Job Number : GED-577R5 / 2000204
 Model Name : 75153-A /GOOD SAMARITAN

Dec 5, 2019
 2:39 PM
 Checked By: SWS

Member Point Loads (BLC 1 : Dead Load) (Continued)

	Member Label	Direction	Magnitude[lb,lb-ft]	Location[in, %]
12	M20	Y	-405	40
13	M41	Y	-300	0
14	M42	Y	-300	0
15	M41	Y	-300	%50
16	M42	Y	-300	%50
17	M2	Y	-200	%100
18	M3	Y	-50	%100
19	M22	Y	-385	200
20	M6	Y	-100	%100

Member Distributed Loads (BLC 1 : Dead Load)

	Member Label	Direction	Start Magnitude[lb/ft,F,psf]	End Magnitude[lb/ft,F,p...]	Start Location[in, %]	End Location[in, %]
1	M21	PY	-28	-28	0	0
2	M22	PY	-28	-28	0	0
3	M23	PY	-28	-28	0	0
4	M24	PY	-28	-28	0	0

Member Distributed Loads (BLC 11 : BLC 9 Transient Area Loads)

	Member Label	Direction	Start Magnitude[lb/ft,F,psf]	End Magnitude[lb/ft,F,p...]	Start Location[in, %]	End Location[in, %]
1	M1	Y	-2.76	-3.87	0	25.4
2	M1	Y	-3.87	-5.75	25.4	50.8
3	M1	Y	-5.75	-4.94	50.8	76.2
4	M1	Y	-4.94	-2.5	76.2	101.6
5	M1	Y	-2.5	-1.91	101.6	127
6	M2	Y	-3.82	-2.65	0	25.4
7	M2	Y	-2.65	-3.85	25.4	50.8
8	M2	Y	-3.85	-5.65	50.8	76.2
9	M2	Y	-5.65	-4.27	76.2	101.6
10	M2	Y	-4.27	-1.5	101.6	127
11	M3	Y	-1.88	-2.1	0	25.4
12	M3	Y	-2.1	-3.48	25.4	50.8
13	M3	Y	-3.48	-6.13	50.8	76.2
14	M3	Y	-6.13	-5.03	76.2	101.6
15	M3	Y	-5.03	-2.4	101.6	127
16	M4	Y	-1.88	-1.98	0	25.4
17	M4	Y	-1.98	-3.52	25.4	50.8
18	M4	Y	-3.52	-6.34	50.8	76.2
19	M4	Y	-6.34	-4.81	76.2	101.6
20	M4	Y	-4.81	-1.8	101.6	127
21	M5	Y	-1.9	-2.33	0	25.4
22	M5	Y	-2.33	-4.16	25.4	50.8
23	M5	Y	-4.16	-7.26	50.8	76.2
24	M5	Y	-7.26	-6.44	76.2	101.6
25	M5	Y	-6.44	-1.82	101.6	127
26	M6	Y	-2.93	-2.6	0	25.4
27	M6	Y	-2.6	-4.1	25.4	50.8
28	M6	Y	-4.1	-7.3	50.8	76.2
29	M6	Y	-7.3	-7.57	76.2	101.6
30	M6	Y	-7.57	-5.06	101.6	127
31	M7	Y	-2.3	-2.34	0	9.6
32	M7	Y	-2.34	-5.99	9.6	19.2
33	M7	Y	-5.99	-7.04	19.2	28.8
34	M7	Y	-7.04	-3.56	28.8	38.4
35	M7	Y	-3.56	-2.3	38.4	48
36	M8	Y	-1.85	-3.36	4.8	17.6



Company : Morrison Hershfield
 Designer : ML
 Job Number : GED-577R5 / 2000204
 Model Name : 75153-A /GOOD SAMARITAN

Dec 5, 2019
 2:39 PM
 Checked By: SWS

Member Distributed Loads (BLC 11 : BLC 9 Transient Area Loads) (Continued)

Member Label	Direction	Start Magnitude[lb/ft,F,psf]	End Magnitude[lb/ft,F,p...	Start Location[in, %]	End Location[in, %]	
37	M8	Y	-3.36	-3.05	17.6	30.4
38	M8	Y	-3.05	-.93	30.4	43.2
39	M9	Y	-.97	-2.99	0	12
40	M9	Y	-2.99	-6.02	12	24
41	M9	Y	-6.02	-5.15	24	36
42	M9	Y	-5.15	-.36	36	48
43	M10	Y	-.93	-3.05	5.2	19.07
44	M10	Y	-3.05	-3.36	19.07	32.93
45	M10	Y	-3.36	-1.85	32.93	46.8
46	M11	Y	-.44	-4.74	0	13
47	M11	Y	-4.74	-6.57	13	26
48	M11	Y	-6.57	-4.05	26	39
49	M11	Y	-4.05	-.44	39	52
50	M12	Y	-1.76	-1.76		24
51	M13	Y	-3.4	-3.4	.0004422	24
52	M14	Y	-.45	-3.58	0	10.4
53	M14	Y	-3.58	-5.57	10.4	20.8
54	M14	Y	-5.57	-5.55	20.8	31.2
55	M14	Y	-5.55	-3.68	31.2	41.6
56	M14	Y	-3.68	-.82	41.6	52
57	M15	Y	-4.66	-2.48	5.2	14.56
58	M15	Y	-2.48	-2.73	14.56	23.92
59	M15	Y	-2.73	-3.92	23.92	33.28
60	M15	Y	-3.92	-2.24	33.28	42.64
61	M15	Y	-2.24	.03	42.64	52
62	M16	Y	-.15	-2.39	0	8.64
63	M16	Y	-2.39	-3.88	8.64	17.28
64	M16	Y	-3.88	-4.15	17.28	25.92
65	M16	Y	-4.15	-3.69	25.92	34.56
66	M16	Y	-3.69	-.2	34.56	43.2
67	M17	Y	-.46	-2.95	.02	10.01
68	M17	Y	-2.95	-4.2	10.01	20.01
69	M17	Y	-4.2	-4.21	20.01	30
70	M17	Y	-4.21	-4.2	30	39.99
71	M17	Y	-4.2	-2.95	39.99	49.99
72	M17	Y	-2.95	-.46	49.99	59.98
73	M18	Y	-.11	-2.74	0	8.64
74	M18	Y	-2.74	-4.76	8.64	17.28
75	M18	Y	-4.76	-7.01	17.28	25.92
76	M18	Y	-7.01	-4.45	25.92	34.56
77	M18	Y	-4.45	-.11	34.56	43.2
78	M19	Y	-3.23	-4.99	6	18
79	M19	Y	-4.99	-5.9	18	30
80	M19	Y	-5.9	-5.04	30	42
81	M19	Y	-5.04	-3.27	42	54
82	M20	Y	-1.01	-1.73	0	9.6
83	M20	Y	-1.73	-2.97	9.6	19.2
84	M20	Y	-2.97	-3.17	19.2	28.8
85	M20	Y	-3.17	-1.81	28.8	38.4
86	M20	Y	-1.81	-.44	38.4	48
87	M21	Y	-3.03	-2.57	0	25.54
88	M21	Y	-2.57	-1.87	25.54	51.08
89	M21	Y	-1.87	-.92	51.08	76.62
90	M21	Y	-.92	-.98	76.62	102.15
91	M21	Y	-.98	-1	102.15	127.69
92	M21	Y	-1	-.94	127.69	153.23
93	M21	Y	-.94	-1.45	153.23	178.77



Company : Morrison Hershfield
 Designer : ML
 Job Number : GED-577R5 / 2000204
 Model Name : 75153-A /GOOD SAMARITAN

Dec 5, 2019
 2:39 PM
 Checked By: SWS

Member Distributed Loads (BLC 11 : BLC 9 Transient Area Loads) (Continued)

	Member Label	Direction	Start Magnitude[lb/ft.F.psf]	End Magnitude[lb/ft.F.p...	Start Location[in.%]	End Location[in.%]
94	M21	Y	-1.45	-1	178.77	204.31
95	M21	Y	-1	-.94	204.31	229.85
96	M21	Y	-.94	-1.22	229.85	255.38
97	M21	Y	-1.22	-1.1	255.38	280.92
98	M21	Y	-1.1	-1.45	280.92	306.46
99	M21	Y	-1.45	-2.04	306.46	332
100	M22	Y	-.62	-.45	0	25.54
101	M22	Y	-.45	-.45	25.54	51.08
102	M22	Y	-.45	-.54	51.08	76.62
103	M22	Y	-.54	-1.75	76.62	102.15
104	M22	Y	-1.75	-2.59	102.15	127.69
105	M22	Y	-2.59	-2.4	127.69	153.23
106	M22	Y	-2.4	-2.26	153.23	178.77
107	M22	Y	-2.26	-2.47	178.77	204.31
108	M22	Y	-2.47	-2.49	204.31	229.85
109	M22	Y	-2.49	-.99	229.85	255.38
110	M22	Y	-.99	-1.55	255.38	280.92
111	M22	Y	-1.55	-2.79	280.92	306.46
112	M22	Y	-2.79	-2.18	306.46	332
113	M23	Y	-.15	-2.71	0	25.4
114	M23	Y	-2.71	-3.9	25.4	50.8
115	M23	Y	-3.9	-2.84	50.8	76.2
116	M23	Y	-2.84	-1.67	76.2	101.6
117	M23	Y	-1.67	-.62	101.6	127
118	M24	Y	-1.32	-1.44	12.7	33.02
119	M24	Y	-1.44	-2.5	33.02	53.34
120	M24	Y	-2.5	-5.2	53.34	73.66
121	M24	Y	-5.2	-4.9	73.66	93.98
122	M24	Y	-4.9	-.86	93.98	114.3
123	M41	Y	-.31	-3.42	0	9.6
124	M41	Y	-3.42	-4.99	9.6	19.2
125	M41	Y	-4.99	-6.05	19.2	28.8
126	M41	Y	-6.05	-4.5	28.8	38.4
127	M41	Y	-4.5	-.31	38.4	48
128	M42	Y	-.72	-1.8	0	9.6
129	M42	Y	-1.8	-2.55	9.6	19.2
130	M42	Y	-2.55	-2.56	19.2	28.8
131	M42	Y	-2.56	-1.79	28.8	38.4
132	M42	Y	-1.79	-.68	38.4	48

Member Distributed Loads (BLC 12 : BLC 10 Transient Area Loads)

	Member Label	Direction	Start Magnitude[lb/ft.F.psf]	End Magnitude[lb/ft.F.p...	Start Location[in.%]	End Location[in.%]
1	M1	Y	-34.53	-48.35	0	25.4
2	M1	Y	-48.35	-71.83	25.4	50.8
3	M1	Y	-71.83	-61.71	50.8	76.2
4	M1	Y	-61.71	-31.3	76.2	101.6
5	M1	Y	-31.3	-23.88	101.6	127
6	M2	Y	-47.73	-33.08	0	25.4
7	M2	Y	-33.08	-48.17	25.4	50.8
8	M2	Y	-48.17	-70.65	50.8	76.2
9	M2	Y	-70.65	-53.38	76.2	101.6
10	M2	Y	-53.38	-18.69	101.6	127
11	M3	Y	-23.51	-26.29	0	25.4
12	M3	Y	-26.29	-43.47	25.4	50.8
13	M3	Y	-43.47	-76.58	50.8	76.2
14	M3	Y	-76.58	-62.86	76.2	101.6



Company : Morrison Hershfield
 Designer : ML
 Job Number : GED-577R5 / 2000204
 Model Name : 75153-A /GOOD SAMARITAN

Dec 5, 2019
 2:39 PM
 Checked By: SWS

Member Distributed Loads (BLC 12 : BLC 10 Transient Area Loads) (Continued)

Member Label	Direction	Start Magnitude[lb/ft,F.psf]	End Magnitude[lb/ft,F.p...	Start Location[in,%]	End Location[in,%]	
15	M3	Y	-62.86	-3.02	101.6	127
16	M4	Y	-23.55	-24.72	0	25.4
17	M4	Y	-24.72	-44.06	25.4	50.8
18	M4	Y	-44.06	-79.26	50.8	76.2
19	M4	Y	-79.26	-60.1	76.2	101.6
20	M4	Y	-60.1	-2.28	101.6	127
21	M5	Y	-23.81	-29.16	0	25.4
22	M5	Y	-29.16	-51.99	25.4	50.8
23	M5	Y	-51.99	-90.75	50.8	76.2
24	M5	Y	-90.75	-80.48	76.2	101.6
25	M5	Y	-80.48	-22.72	101.6	127
26	M6	Y	-36.69	-32.46	0	25.4
27	M6	Y	-32.46	-51.3	25.4	50.8
28	M6	Y	-51.3	-91.29	50.8	76.2
29	M6	Y	-91.29	-94.63	76.2	101.6
30	M6	Y	-94.63	-63.22	101.6	127
31	M7	Y	-2.93	-29.23	0	9.6
32	M7	Y	-29.23	-74.93	9.6	19.2
33	M7	Y	-74.93	-87.94	19.2	28.8
34	M7	Y	-87.94	-44.54	28.8	38.4
35	M7	Y	-44.54	-2.93	38.4	48
36	M8	Y	-23.16	-41.99	4.8	17.6
37	M8	Y	-41.99	-38.16	17.6	30.4
38	M8	Y	-38.16	-11.67	30.4	43.2
39	M9	Y	-12.15	-37.36	0	12
40	M9	Y	-37.36	-75.19	12	24
41	M9	Y	-75.19	-64.41	24	36
42	M9	Y	-64.41	-4.56	36	48
43	M10	Y	-11.67	-38.15	5.2	19.07
44	M10	Y	-38.15	-41.97	19.07	32.93
45	M10	Y	-41.97	-23.13	32.93	46.8
46	M11	Y	-5.54	-59.2	0	13
47	M11	Y	-59.2	-82.1	13	26
48	M11	Y	-82.1	-50.6	26	39
49	M11	Y	-50.6	-5.54	39	52
50	M12	Y	-22	-22		24
51	M13	Y	-42.52	-42.52	.0004422	24
52	M14	Y	-5.61	-44.78	0	10.4
53	M14	Y	-44.78	-69.56	10.4	20.8
54	M14	Y	-69.56	-69.33	20.8	31.2
55	M14	Y	-69.33	-46	31.2	41.6
56	M14	Y	-46	-10.21	41.6	52
57	M15	Y	-58.27	-30.97	5.2	14.56
58	M15	Y	-30.97	-34.15	14.56	23.92
59	M15	Y	-34.15	-49.04	23.92	33.28
60	M15	Y	-49.04	-27.99	33.28	42.64
61	M15	Y	-27.99	.43	42.64	52
62	M16	Y	-1.86	-29.93	0	8.64
63	M16	Y	-29.93	-48.51	8.64	17.28
64	M16	Y	-48.51	-51.89	17.28	25.92
65	M16	Y	-51.89	-46.12	25.92	34.56
66	M16	Y	-46.12	-25.01	34.56	43.2
67	M17	Y	-5.79	-36.92	.02	10.01
68	M17	Y	-36.92	-52.56	10.01	20.01
69	M17	Y	-52.56	-52.63	20.01	30
70	M17	Y	-52.63	-52.55	30	39.99
71	M17	Y	-52.55	-36.91	39.99	49.99



Company : Morrison Hershfield
 Designer : ML
 Job Number : GED-577R5 / 2000204
 Model Name : 75153-A /GOOD SAMARITAN

Dec 5, 2019
 2:39 PM
 Checked By: SWS

Member Distributed Loads (BLC 12 : BLC 10 Transient Area Loads) (Continued)

Member Label	Direction	Start Magnitude[lb/ft,F,psf]	End Magnitude[lb/ft,F,p...	Start Location[in.%]	End Location[in.%]	
72	M17	Y	-36.91	-5.8	49.99	59.98
73	M18	Y	-1.33	-34.2	0	8.64
74	M18	Y	-34.2	-59.46	8.64	17.28
75	M18	Y	-59.46	-87.57	17.28	25.92
76	M18	Y	-87.57	-55.66	25.92	34.56
77	M18	Y	-55.66	-1.33	34.56	43.2
78	M19	Y	-40.32	-62.4	6	18
79	M19	Y	-62.4	-73.74	18	30
80	M19	Y	-73.74	-62.98	30	42
81	M19	Y	-62.98	-40.87	42	54
82	M20	Y	-12.67	-21.63	0	9.6
83	M20	Y	-21.63	-37.11	9.6	19.2
84	M20	Y	-37.11	-39.59	19.2	28.8
85	M20	Y	-39.59	-22.57	28.8	38.4
86	M20	Y	-22.57	-5.54	38.4	48
87	M21	Y	-37.86	-32.18	0	25.54
88	M21	Y	-32.18	-23.35	25.54	51.08
89	M21	Y	-23.35	-11.5	51.08	76.62
90	M21	Y	-11.5	-12.23	76.62	102.15
91	M21	Y	-12.23	-12.48	102.15	127.69
92	M21	Y	-12.48	-11.74	127.69	153.23
93	M21	Y	-11.74	-18.17	153.23	178.77
94	M21	Y	-18.17	-12.53	178.77	204.31
95	M21	Y	-12.53	-11.76	204.31	229.85
96	M21	Y	-11.76	-15.22	229.85	255.38
97	M21	Y	-15.22	-13.72	255.38	280.92
98	M21	Y	-13.72	-18.1	280.92	306.46
99	M21	Y	-18.1	-25.45	306.46	332
100	M22	Y	-7.81	-5.61	0	25.54
101	M22	Y	-5.61	-5.61	25.54	51.08
102	M22	Y	-5.61	-6.73	51.08	76.62
103	M22	Y	-6.73	-21.93	76.62	102.15
104	M22	Y	-21.93	-32.32	102.15	127.69
105	M22	Y	-32.32	-30	127.69	153.23
106	M22	Y	-30	-28.27	153.23	178.77
107	M22	Y	-28.27	-30.85	178.77	204.31
108	M22	Y	-30.85	-31.12	204.31	229.85
109	M22	Y	-31.12	-12.36	229.85	255.38
110	M22	Y	-12.36	-19.35	255.38	280.92
111	M22	Y	-19.35	-34.82	280.92	306.46
112	M22	Y	-34.82	-27.27	306.46	332
113	M23	Y	-1.87	-33.86	0	25.4
114	M23	Y	-33.86	-48.71	25.4	50.8
115	M23	Y	-48.71	-35.56	50.8	76.2
116	M23	Y	-35.56	-20.83	76.2	101.6
117	M23	Y	-20.83	-7.7	101.6	127
118	M24	Y	-16.55	-18.01	12.7	33.02
119	M24	Y	-18.01	-31.19	33.02	53.34
120	M24	Y	-31.19	-65.05	53.34	73.66
121	M24	Y	-65.05	-61.23	73.66	93.98
122	M24	Y	-61.23	-10.77	93.98	114.3
123	M41	Y	-3.91	-42.71	0	9.6
124	M41	Y	-42.71	-62.33	9.6	19.2
125	M41	Y	-62.33	-75.56	19.2	28.8
126	M41	Y	-75.56	-56.25	28.8	38.4
127	M41	Y	-56.25	-3.91	38.4	48
128	M42	Y	-9.06	-22.47	0	9.6



Company : Morrison Hershfield
 Designer : ML
 Job Number : GED-577R5 / 2000204
 Model Name : 75153-A /GOOD SAMARITAN

Dec 5, 2019
 2:39 PM
 Checked By: SWS

Member Distributed Loads (BLC 12 : BLC 10 Transient Area Loads) (Continued)

	Member Label	Direction	Start Magnitude[lb/ft.F.psf]	End Magnitude[lb/ft.F.p...	Start Location[in.%]	End Location[in.%]
129	M42	Y	-22.47	-31.93	9.6	19.2
130	M42	Y	-31.93	-32.02	19.2	28.8
131	M42	Y	-32.02	-22.39	28.8	38.4
132	M42	Y	-22.39	-8.46	38.4	48

Member Distributed Loads (BLC 13 : BLC 8 Transient Area Loads)

	Member Label	Direction	Start Magnitude[lb/ft.F.psf]	End Magnitude[lb/ft.F.p...	Start Location[in.%]	End Location[in.%]
1	M1	Y	-41.44	-58.02	0	25.4
2	M1	Y	-58.02	-86.2	25.4	50.8
3	M1	Y	-86.2	-74.06	50.8	76.2
4	M1	Y	-74.06	-37.56	76.2	101.6
5	M1	Y	-37.56	-28.65	101.6	127
6	M2	Y	-57.28	-39.7	0	25.4
7	M2	Y	-39.7	-57.8	25.4	50.8
8	M2	Y	-57.8	-84.79	50.8	76.2
9	M2	Y	-84.79	-64.06	76.2	101.6
10	M2	Y	-64.06	-22.43	101.6	127
11	M3	Y	-28.21	-31.55	0	25.4
12	M3	Y	-31.55	-52.16	25.4	50.8
13	M3	Y	-52.16	-91.89	50.8	76.2
14	M3	Y	-91.89	-75.43	76.2	101.6
15	M3	Y	-75.43	-3.62	101.6	127
16	M4	Y	-28.26	-29.67	0	25.4
17	M4	Y	-29.67	-52.87	25.4	50.8
18	M4	Y	-52.87	-95.11	50.8	76.2
19	M4	Y	-95.11	-72.12	76.2	101.6
20	M4	Y	-72.12	-2.74	101.6	127
21	M5	Y	-28.57	-34.99	0	25.4
22	M5	Y	-34.99	-62.39	25.4	50.8
23	M5	Y	-62.39	-108.9	50.8	76.2
24	M5	Y	-108.9	-96.58	76.2	101.6
25	M5	Y	-96.58	-27.27	101.6	127
26	M6	Y	-44.02	-38.95	0	25.4
27	M6	Y	-38.95	-61.56	25.4	50.8
28	M6	Y	-61.56	-109.55	50.8	76.2
29	M6	Y	-109.55	-113.55	76.2	101.6
30	M6	Y	-113.55	-75.87	101.6	127
31	M7	Y	-3.52	-35.08	0	9.6
32	M7	Y	-35.08	-89.92	9.6	19.2
33	M7	Y	-89.92	-105.53	19.2	28.8
34	M7	Y	-105.53	-53.44	28.8	38.4
35	M7	Y	-53.44	-3.52	38.4	48
36	M8	Y	-27.8	-50.39	4.8	17.6
37	M8	Y	-50.39	-45.79	17.6	30.4
38	M8	Y	-45.79	-14	30.4	43.2
39	M9	Y	-14.58	-44.84	0	12
40	M9	Y	-44.84	-90.23	12	24
41	M9	Y	-90.23	-77.29	24	36
42	M9	Y	-77.29	-5.47	36	48
43	M10	Y	-14	-45.79	5.2	19.07
44	M10	Y	-45.79	-50.37	19.07	32.93
45	M10	Y	-50.37	-27.75	32.93	46.8
46	M11	Y	-6.65	-71.04	0	13
47	M11	Y	-71.04	-98.52	13	26
48	M11	Y	-98.52	-60.72	26	39
49	M11	Y	-60.72	-6.65	39	52



Company : Morrison Hershfield
 Designer : ML
 Job Number : GED-577R5 / 2000204
 Model Name : 75153-A /GOOD SAMARITAN

Dec 5, 2019
 2:39 PM
 Checked By: SWS

Member Distributed Loads (BLC 13 : BLC 8 Transient Area Loads) (Continued)

Member Label	Direction	Start Magnitude[lb/ft.F.psf]	End Magnitude[lb/ft.F.p...	Start Location[in.%]	End Location[in.%]
50	M12	Y	-26.4	-26.4	24
51	M13	Y	-51.02	-51.02	.0004422 24
52	M14	Y	-6.73	-53.74	0 10.4
53	M14	Y	-53.74	-83.48	10.4 20.8
54	M14	Y	-83.48	-83.2	20.8 31.2
55	M14	Y	-83.2	-55.2	31.2 41.6
56	M14	Y	-55.2	-12.25	41.6 52
57	M15	Y	-69.92	-37.17	5.2 14.56
58	M15	Y	-37.17	-40.98	14.56 23.92
59	M15	Y	-40.98	-58.84	23.92 33.28
60	M15	Y	-58.84	-33.59	33.28 42.64
61	M15	Y	-33.59	.52	42.64 52
62	M16	Y	-2.24	-35.91	0 8.64
63	M16	Y	-35.91	-58.21	8.64 17.28
64	M16	Y	-58.21	-62.27	17.28 25.92
65	M16	Y	-62.27	-55.34	25.92 34.56
66	M16	Y	-55.34	-30.01	34.56 43.2
67	M17	Y	-6.95	-44.3	.02 10.01
68	M17	Y	-44.3	-63.07	10.01 20.01
69	M17	Y	-63.07	-63.15	20.01 30
70	M17	Y	-63.15	-63.06	30 39.99
71	M17	Y	-63.06	-44.29	39.99 49.99
72	M17	Y	-44.29	-6.96	49.99 59.98
73	M18	Y	-1.6	-41.04	0 8.64
74	M18	Y	-41.04	-71.35	8.64 17.28
75	M18	Y	-71.35	-105.08	17.28 25.92
76	M18	Y	-105.08	-66.79	25.92 34.56
77	M18	Y	-66.79	-1.6	34.56 43.2
78	M19	Y	-48.39	-74.88	6 18
79	M19	Y	-74.88	-88.49	18 30
80	M19	Y	-88.49	-75.58	30 42
81	M19	Y	-75.58	-49.05	42 54
82	M20	Y	-15.21	-25.96	0 9.6
83	M20	Y	-25.96	-44.53	9.6 19.2
84	M20	Y	-44.53	-47.51	19.2 28.8
85	M20	Y	-47.51	-27.08	28.8 38.4
86	M20	Y	-27.08	-6.64	38.4 48
87	M21	Y	-45.43	-38.61	0 25.54
88	M21	Y	-38.61	-28.02	25.54 51.08
89	M21	Y	-28.02	-13.8	51.08 76.62
90	M21	Y	-13.8	-14.68	76.62 102.15
91	M21	Y	-14.68	-14.97	102.15 127.69
92	M21	Y	-14.97	-14.09	127.69 153.23
93	M21	Y	-14.09	-21.8	153.23 178.77
94	M21	Y	-21.8	-15.04	178.77 204.31
95	M21	Y	-15.04	-14.11	204.31 229.85
96	M21	Y	-14.11	-18.26	229.85 255.38
97	M21	Y	-18.26	-16.47	255.38 280.92
98	M21	Y	-16.47	-21.72	280.92 306.46
99	M21	Y	-21.72	-30.54	306.46 332
100	M22	Y	-9.37	-6.73	0 25.54
101	M22	Y	-6.73	-6.73	25.54 51.08
102	M22	Y	-6.73	-8.08	51.08 76.62
103	M22	Y	-8.08	-26.32	76.62 102.15
104	M22	Y	-26.32	-38.79	102.15 127.69
105	M22	Y	-38.79	-36	127.69 153.23
106	M22	Y	-36	-33.92	153.23 178.77



Company : Morrison Hershfield
 Designer : ML
 Job Number : GED-577R5 / 2000204
 Model Name : 75153-A /GOOD SAMARITAN

Dec 5, 2019
 2:39 PM
 Checked By: SWS

Member Distributed Loads (BLC 13 : BLC 8 Transient Area Loads) (Continued)

Member Label	Direction	Start Magnitude[lb/ft,F.psf]	End Magnitude[lb/ft,F.p...	Start Location[in,%]	End Location[in,%]
107	M22	Y	-33.92	-37.02	178.77 204.31
108	M22	Y	-37.02	-37.35	204.31 229.85
109	M22	Y	-37.35	-14.83	229.85 255.38
110	M22	Y	-14.83	-23.22	255.38 280.92
111	M22	Y	-23.22	-41.78	280.92 306.46
112	M22	Y	-41.78	-32.72	306.46 332
113	M23	Y	-2.24	-40.63	0 25.4
114	M23	Y	-40.63	-58.46	25.4 50.8
115	M23	Y	-58.46	-42.67	50.8 76.2
116	M23	Y	-42.67	-25	76.2 101.6
117	M23	Y	-25	-9.25	101.6 127
118	M24	Y	-19.86	-21.61	12.7 33.02
119	M24	Y	-21.61	-37.43	33.02 53.34
120	M24	Y	-37.43	-78.06	53.34 73.66
121	M24	Y	-78.06	-73.47	73.66 93.98
122	M24	Y	-73.47	-12.92	93.98 114.3
123	M41	Y	-4.69	-51.25	0 9.6
124	M41	Y	-51.25	-74.79	9.6 19.2
125	M41	Y	-74.79	-90.68	19.2 28.8
126	M41	Y	-90.68	-67.5	28.8 38.4
127	M41	Y	-67.5	-4.69	38.4 48
128	M42	Y	-10.87	-26.97	0 9.6
129	M42	Y	-26.97	-38.32	9.6 19.2
130	M42	Y	-38.32	-38.43	19.2 28.8
131	M42	Y	-38.43	-26.87	28.8 38.4
132	M42	Y	-26.87	-10.15	38.4 48

Load Combinations

Description	S...	P...	S...	BLC	Fa...	BLC	Fa...	BLC	Fa...	B...	Fa...	B...	Fa...	B...	Fa...	B...	Fa...	B...	Fa...
1	1.4 DL	Y	Y	1	1.4														
2	1.2 DL + 1.0 LCA X	Y	Y	1	1.2	5	1												
3	1.2 DL - 1.0 LCA X	Y	Y	1	1.2	5	-1												
4	1.2 DL + 1.0 LCB X	Y	Y	1	1.2	6	1												
5	1.2 DL - 1.0 LCB X	Y	Y	1	1.2	6	-1												
6	1.2 DL + 1.0 LCC X	Y	Y	1	1.2	7	1												
7	1.2 DL + 1.0 LCC X	Y	Y	1	1.2	7	-1												
8	1.2 DL + 1.0 LCA Z	Y	Y	1	1.2	2	1												
9	1.2 DL - 1.0 LCA Z	Y	Y	1	1.2	2	-1												
10	1.2 DL + 1.0 LCB Z	Y	Y	1	1.2	3	1												
11	1.2 DL - 1.0 LCB Z	Y	Y	1	1.2	3	-1												
12	1.2 DL + 1.0 LCC Z	Y	Y	1	1.2	4	1												
13	1.2 DL - 1.0 LCC Z	Y	Y	1	1.2	4	-1												
14	0.9 DL + 1.0 LCA X	Y	Y	1	.9	5	1												
15	0.9 DL - 1.0 LCA X	Y	Y	1	.9	5	-1												
16	0.9 DL + 1.0 LCB X	Y	Y	1	.9	6	1												
17	0.9 DL - 1.0 LCB X	Y	Y	1	.9	6	-1												
18	0.9 DL + 1.0 LCC X	Y	Y	1	.9	7	1												
19	0.9 DL + 1.0 LCC X	Y	Y	1	.9	7	-1												
20	0.9 DL + 1.0 LCA Z	Y	Y	1	.9	2	1												
21	0.9 DL - 1.0 LCA Z	Y	Y	1	.9	2	-1												
22	0.9 DL + 1.0 LCB Z	Y	Y	1	.9	3	1												
23	0.9 DL - 1.0 LCB Z	Y	Y	1	.9	3	-1												
24	0.9 DL + 1.0 LCC Z	Y	Y	1	.9	4	1												
25	0.9 DL - 1.0 LCC Z	Y	Y	1	.9	4	-1												
26	IBC 16-1	Y	Y		DL	1.4													



Company : Morrison Hershfield
 Designer : ML
 Job Number : GED-577R5 / 2000204
 Model Name : 75153-A /GOOD SAMARITAN

Dec 5, 2019
 2:39 PM
 Checked By: SWS

Load Combinations (Continued)

	Description	S...	P...	S...	BLC	Fa...	BLC	Fa...	BLC	Fa...	B...	Fa...	B...	Fa...	B...	Fa...	B...	Fa...	B...	Fa...
27	IBC 16-2 (a)	Y...	Y		DL	1.2	LL	1.6	LLS	1.6										
28	IBC 16-2 (b)	Y...	Y		DL	1.2	LL	1.6	LLS	1.6	SL	.5	S...	.5						
29	IBC 16-3 (c)	Y...	Y		DL	1.2	SL	1.6	SLN	1.6	LL	.5	L...	1						

Envelope Joint Reactions

	Joint		X [lb]	LC	Y [lb]	LC	Z [lb]	LC	MX [lb-ft]	LC	MY [lb-ft]	LC	MZ [lb-ft]	LC
1	N5	max	1521.898	18	9759.458	29	5032.808	24	0	29	0	29	0	29
2		min	-1523.486	19	357.582	24	-4994.045	25	0	1	0	1	0	1
3	N7	max	1435.836	18	9269.093	29	4995.94	12	0	29	0	29	0	29
4		min	-1437.394	19	100.492	25	-5034.163	13	0	1	0	1	0	1
5	N6	max	1524.646	6	8962.089	29	3114.058	24	0	29	0	29	0	29
6		min	-1522.994	7	-244.235	24	-3090.55	25	0	1	0	1	0	1
7	N8	max	1438.552	6	8466.897	29	3091.331	12	0	29	0	29	0	29
8		min	-1437.058	7	-504.681	25	-3115.483	13	0	1	0	1	0	1
9	Totals:	max	5920.599	18	36457.537	29	16233.796	24						
10		min	-5920.599	19	13530.05	24	-16233.796	25						

Envelope AISC 15th(360-16): LRFD Steel Code Checks

Member	Shape	Code Che...	Loc[in]	LC	Shear Check	Loc[in]	Dir	LC	phi*Pn...	phi*...	phi*...	phi*...	Eqn	
1	M1	W8X13	.228	87.313	29	.059	127	y	29	38237...	172...	806...	244...	H1...
2	M2	W8X13	.168	58.208	29	.029	127	y	29	38237...	172...	806...	239...	H1...
3	M3	W8X13	.279	42.333	29	.060	0	y	29	38237...	172...	806...	269...	H1...
4	M4	W8X13	.275	42.333	29	.060	0	y	29	38237...	172...	806...	269...	H1...
5	M5	W8X13	.155	54.24	29	.026	0	y	29	38237...	172...	806...	247...	H1...
6	M6	W8X13	.211	48.948	29	.038	0	y	29	38237...	172...	806...	255...	H1...
7	M7	W8X13	.016	24	29	.018	48	y	29	13634...	172...	806...	42750...	H1...
8	M8	W8X13	.005	23.5	29	.004	0	y	29	13634...	172...	806...	42750...	H1...
9	M9	W8X13	.008	25	29	.006	48	y	29	13634...	172...	806...	42750...	H1...
10	M10	W8X13	.006	26.542	29	.006	52	y	29	13084...	172...	806...	42750...	H1...
11	M11	W8X13	.009	25.458	29	.006	0	y	29	13084...	172...	806...	42750...	H1...
12	M12	W8X13	.001	12	29	.001	24	y	29	16286...	172...	806...	42750...	H1...
13	M13	W8X13	.001	12	29	.003	24	y	29	16286...	172...	806...	42750...	H1...
14	M14	W8X13	.009	26	29	.006	52	y	29	13084...	172...	806...	42750...	H1...
15	M15	W8X13	.006	26.542	29	.007	0	y	29	13084...	172...	806...	42750...	H1...
16	M16	W8X13	.006	24	29	.005	0	y	29	13634...	172...	806...	42750...	H1...
17	M17	W8X13	.017	30	29	.016	0	y	29	11932...	172...	806...	406...	H1...
18	M18	W8X13	.008	24.5	29	.005	0	y	29	13634...	172...	806...	42750...	H1...
19	M19	W8X13	.019	30	29	.014	60	y	29	11932...	172...	806...	410...	H1...
20	M20	W8X13	.013	23	29	.018	48	y	29	13634...	172...	806...	421...	H1...
21	M21	W16X26	.076	166	29	.156	166	y	29	78609.9	345...	20550	165...	H1...
22	M22	W16X26	.080	166	29	.127	166	y	29	78609.9	345...	20550	165...	H1...
23	M23	W10X15	.017	91.281	29	.014	127	y	29	10533...	198...	8625	60000...	H1...
24	M24	W10X15	.016	63.5	29	.018	63.5	y	29	10533...	198...	8625	60000...	H1...
25	M25	HSS4.000X0.226	.843	18	13	.178	0		12	93461...	94500	9513	9513	H1...
26	M26	HSS4.000X0.226	.841	18	12	.178	0		12	93461...	94500	9513	9513	H1...
27	M27	HSS4.000X0.226	.536	18	13	.111	0		13	93461...	94500	9513	9513	H1...
28	M28	HSS4.000X0.226	.534	18	12	.111	0		12	93461...	94500	9513	9513	H1...
29	M41	C6X8.2	.035	24	29	.016	48	y	29	59853...	107...	292...	19350...	H1...
30	M42	C6X8.2	.027	24	29	.013	0	y	29	59853...	107...	292...	19350...	H1...

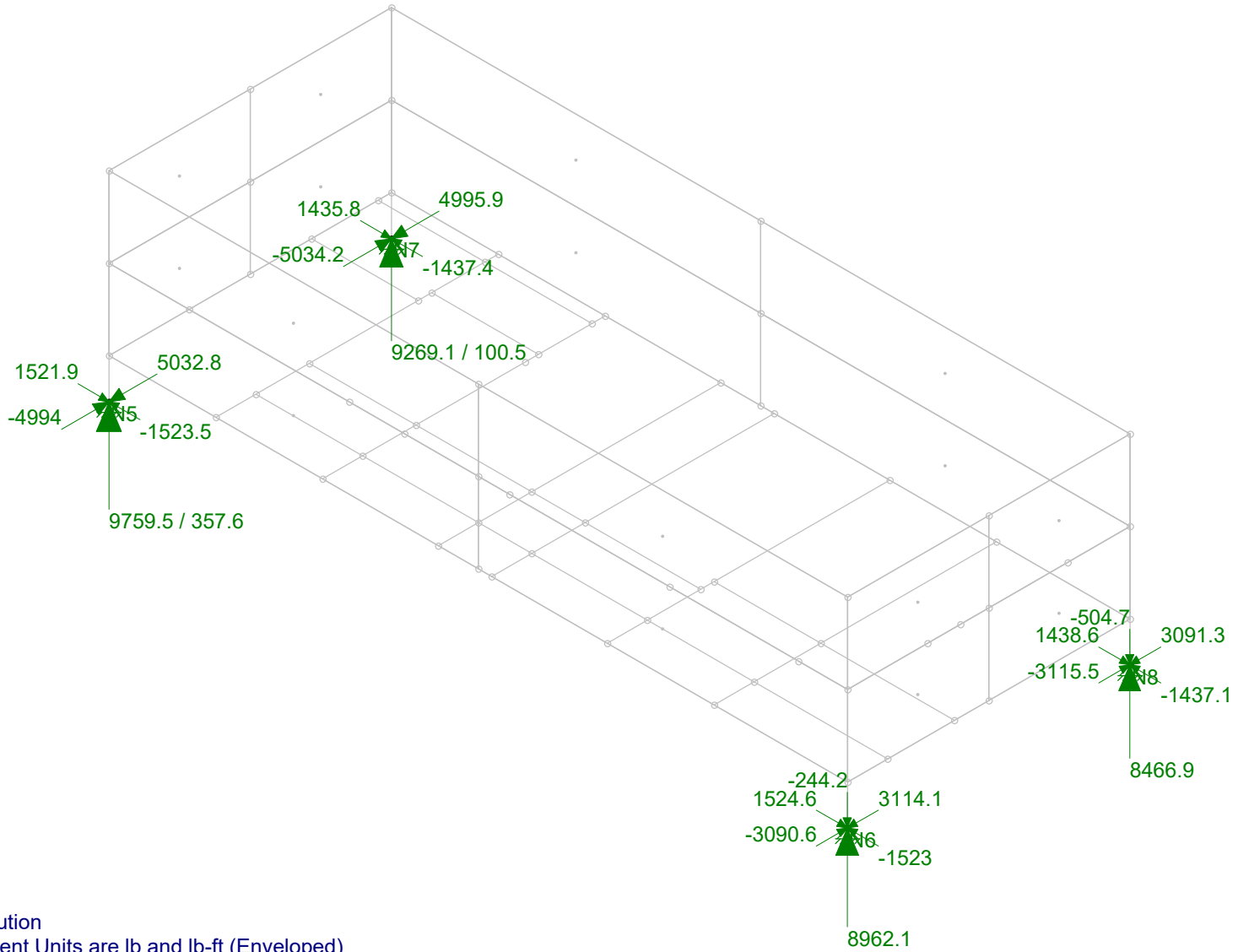
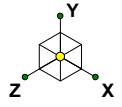

Morrison Hershfield

ML

GED-577R5 / 2000204

75153-A /GOOD SAMARITAN

SK - 14

Dec 5, 2019 at 2:40 PM

Platform Analysis.r3d

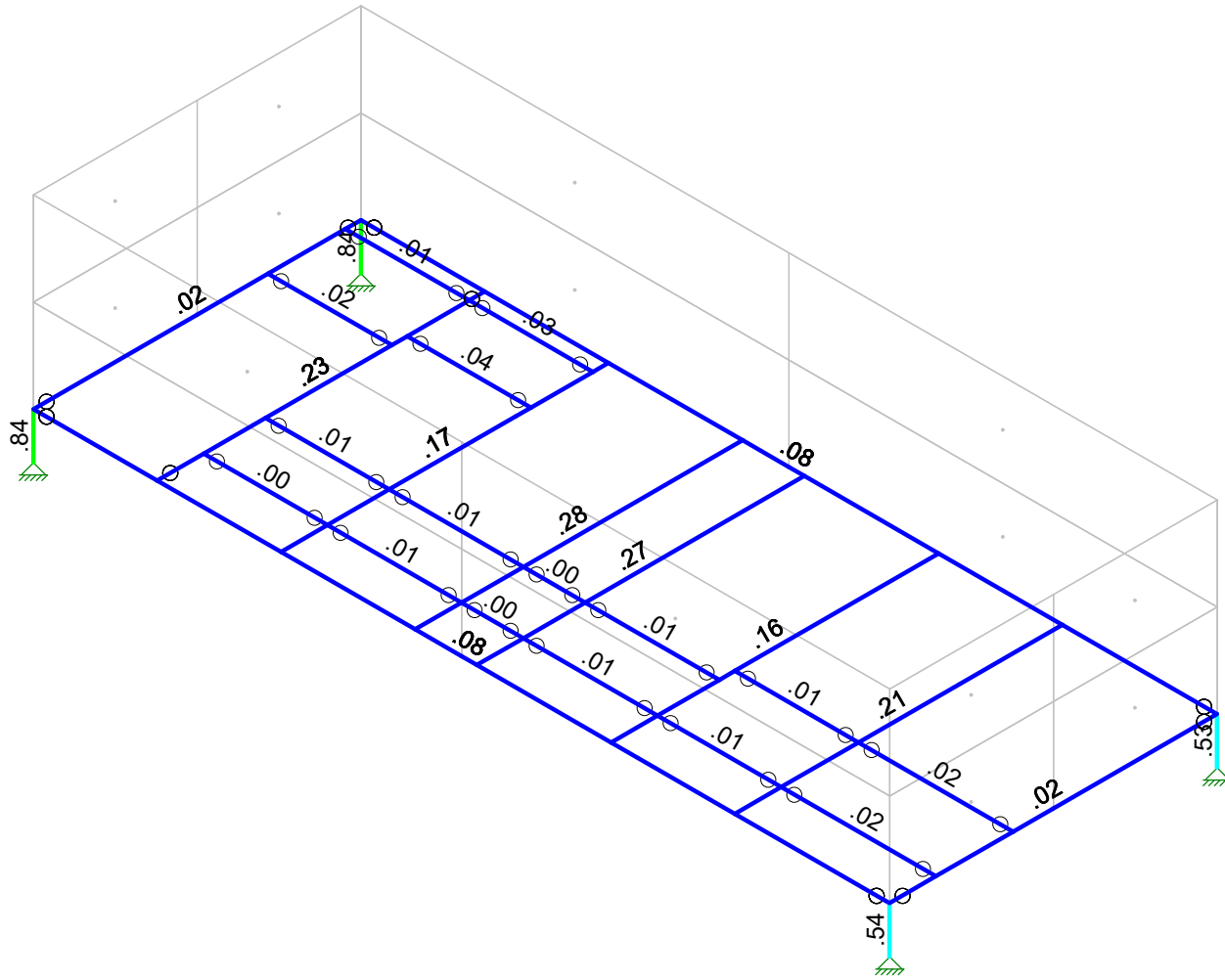
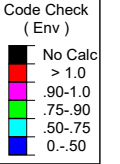
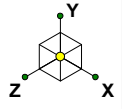

Member Code Checks Displayed (Enveloped)
Envelope Only Solution

Morrison Hershfield	75153-A /GOOD SAMARITAN	SK - 16
ML		Dec 5, 2019 at 2:42 PM
GED-577R5 / 2000204		Platform Analysis.r3d

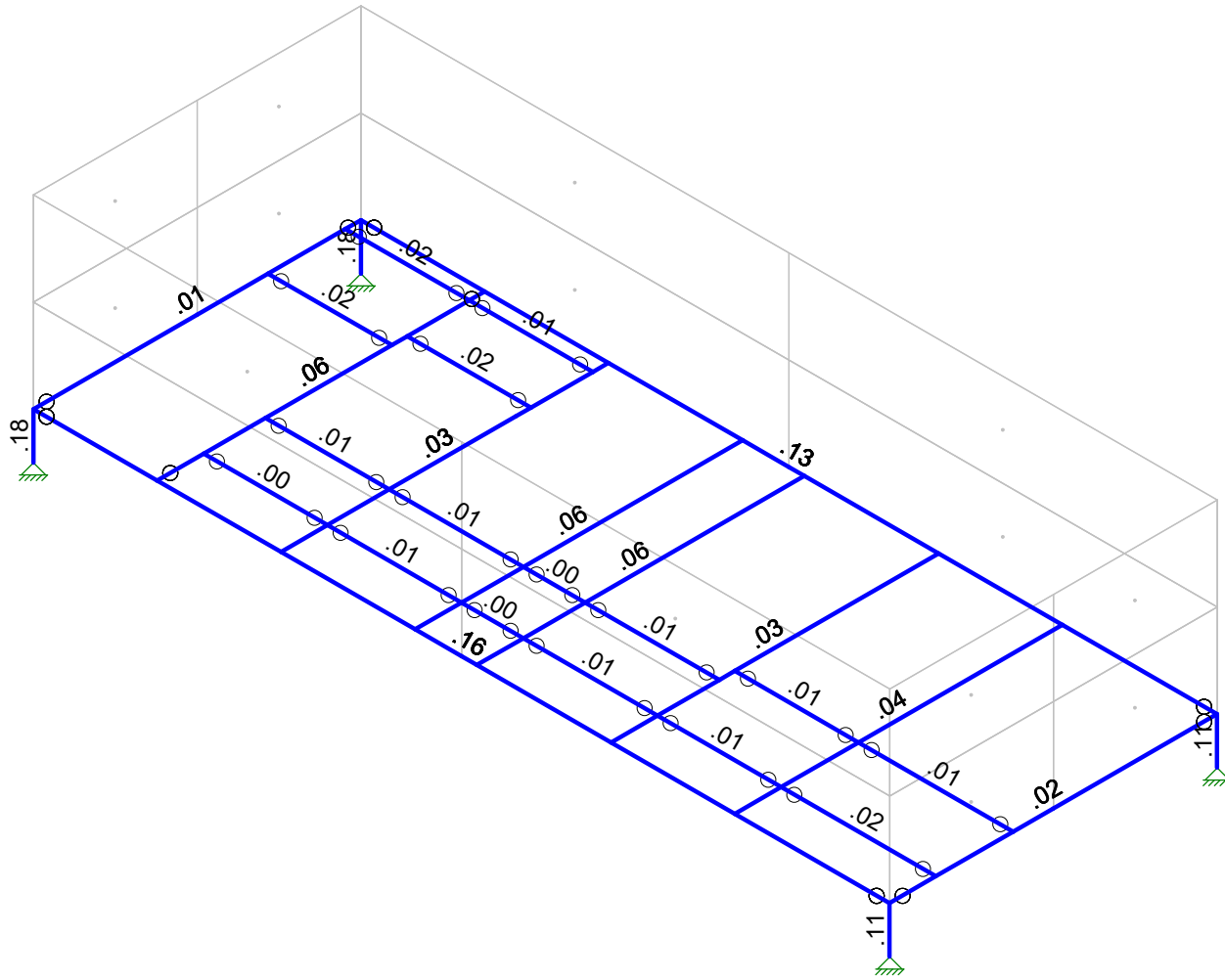
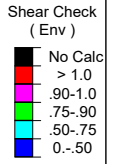
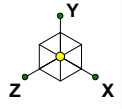

Member Shear Checks Displayed (Enveloped)
Envelope Only Solution

Morrison Hershfield
ML
GED-577R5 / 2000204

75153-A /GOOD SAMARITAN

SK - 17
Dec 5, 2019 at 2:43 PM
Platform Analysis.r3d



Company : Morrison Hershfield
 Designer : ML
 Job Number : GED-577R5 / 2000204
 Model Name : 75153-A /GOOD SAMARITAN

Dec 5, 2019
 3:00 PM
 Checked By: SWS

Hot Rolled Steel Properties

	Label	E [ksi]	G [ksi]	Nu	Therm (/...	Density[k/ft^3]	Yield[ksi]	Ry	Fu[ksi]	Rt
1	A53 Gr.B	29000	11154	.3	.65	.49	35	1.6	60	1.2
2	A36 Gr.36	29000	11154	.3	.65	.49	36	1.5	58	1.2
3	A500 Gr.B Rect	29000	11154	.3	.65	.53	46	1.4	58	1.3
4	A500 Gr.B RND	29000	11154	.3	.65	.53	42	1.4	58	1.3
5	A992	29000	11154	.3	.65	.49	50	1.1	65	1.1

Hot Rolled Steel Section Sets

	Label	Shape	Type	Design List	Material	Desig...	A [in2]	Iyy [in..	Izz [i...	J [in4]
1	Platform Support	HSS4.000X0.2...	Column	HSS Pipe	A500 Gr.B RND	Typical	2.5	4.5	4.5	9.01
2	Platform Plinth Beam (N and S)	W16X26	Beam	Wide Flange	A992	Typical	7.68	9.59	301	.26
3	Platform Plinth Beam (E and W)	W10X15	Beam	Wide Flange	A992	Typical	4.41	2.89	68.9	.1
4	Secondary Framing	W8X13	Beam	Wide Flange	A992	Typical	3.84	2.73	39.6	.09
5	Support Framing	C6X8.2	Beam	Channel	A992	Typical	2.39	.69	13.1	.07

Joint Boundary Conditions

	Joint Label	X [k/in]	Y [k/in]	Z [k/in]	X Rot.[k-ft/rad]	Y Rot.[k-ft/rad]	Z Rot.[k-ft/rad]
1	N5	Reaction	Reaction	Reaction			
2	N7	Reaction	Reaction	Reaction			
3	N6	Reaction	Reaction	Reaction			
4	N8	Reaction	Reaction	Reaction			

Basic Load Cases

	BLC Description	Category	X Gravity	Y Gravity	Z Gravity	Joint	Point	Distribu...	Area(M...	Surface...
1	Dead Load	DL		-1		1	20			
2	Snow Load	SL							1	
3	Weight Of aluminum gr...	DL							1	
4	Live Load	LL								
5	BLC 3 Transient Area ...	None						132		
6	BLC 2 Transient Area ...	None						132		

Member Point Loads (BLC 1 : Dead Load)

	Member Label	Direction	Magnitude[lb,lb-ft]	Location[in, %]
1	M17	Y	-300	9
2	M19	Y	-300	9
3	M17	Y	-300	51
4	M19	Y	-300	51
5	M13	Y	-1175	0
6	M12	Y	-1175	0
7	M13	Y	-1175	%100
8	M12	Y	-1175	%100
9	M7	Y	-405	9
10	M20	Y	-405	9
11	M7	Y	-405	40
12	M20	Y	-405	40
13	M41	Y	-300	0
14	M42	Y	-300	0
15	M41	Y	-300	%50
16	M42	Y	-300	%50
17	M2	Y	-200	%100
18	M3	Y	-50	%100



Company : Morrison Hershfield
 Designer : ML
 Job Number : GED-577R5 / 2000204
 Model Name : 75153-A /GOOD SAMARITAN

Dec 5, 2019
 3:00 PM
 Checked By: SWS

Member Point Loads (BLC 1 : Dead Load) (Continued)

	Member Label	Direction	Magnitude[lb,lb-ft]	Location[in, %]
19	M22	Y	-385	200
20	M6	Y	-100	%100

Member Distributed Loads (BLC 5 : BLC 3 Transient Area Loads)

	Member Label	Direction	Start Magnitude[lb/ft,F,psf]	End Magnitude[lb/ft,F,p...]	Start Location[in, %]	End Location[in, %]
1	M1	Y	-2.76	-3.87	0	25.4
2	M1	Y	-3.87	-5.75	25.4	50.8
3	M1	Y	-5.75	-4.94	50.8	76.2
4	M1	Y	-4.94	-2.5	76.2	101.6
5	M1	Y	-2.5	-1.91	101.6	127
6	M2	Y	-3.82	-2.65	0	25.4
7	M2	Y	-2.65	-3.85	25.4	50.8
8	M2	Y	-3.85	-5.65	50.8	76.2
9	M2	Y	-5.65	-4.27	76.2	101.6
10	M2	Y	-4.27	-1.5	101.6	127
11	M3	Y	-1.88	-2.1	0	25.4
12	M3	Y	-2.1	-3.48	25.4	50.8
13	M3	Y	-3.48	-6.13	50.8	76.2
14	M3	Y	-6.13	-5.03	76.2	101.6
15	M3	Y	-5.03	-2.24	101.6	127
16	M4	Y	-1.88	-1.98	0	25.4
17	M4	Y	-1.98	-3.52	25.4	50.8
18	M4	Y	-3.52	-6.34	50.8	76.2
19	M4	Y	-6.34	-4.81	76.2	101.6
20	M4	Y	-4.81	-1.18	101.6	127
21	M5	Y	-1.9	-2.33	0	25.4
22	M5	Y	-2.33	-4.16	25.4	50.8
23	M5	Y	-4.16	-7.26	50.8	76.2
24	M5	Y	-7.26	-6.44	76.2	101.6
25	M5	Y	-6.44	-1.82	101.6	127
26	M6	Y	-2.93	-2.6	0	25.4
27	M6	Y	-2.6	-4.1	25.4	50.8
28	M6	Y	-4.1	-7.3	50.8	76.2
29	M6	Y	-7.3	-7.57	76.2	101.6
30	M6	Y	-7.57	-5.06	101.6	127
31	M7	Y	-2.34	-2.34	0	9.6
32	M7	Y	-2.34	-5.99	9.6	19.2
33	M7	Y	-5.99	-7.04	19.2	28.8
34	M7	Y	-7.04	-3.56	28.8	38.4
35	M7	Y	-3.56	-2.3	38.4	48
36	M8	Y	-1.85	-3.36	4.8	17.6
37	M8	Y	-3.36	-3.05	17.6	30.4
38	M8	Y	-3.05	-.93	30.4	43.2
39	M9	Y	-.97	-2.99	0	12
40	M9	Y	-2.99	-6.02	12	24
41	M9	Y	-6.02	-5.15	24	36
42	M9	Y	-5.15	-.36	36	48
43	M10	Y	-.93	-3.05	5.2	19.07
44	M10	Y	-3.05	-3.36	19.07	32.93
45	M10	Y	-3.36	-1.85	32.93	46.8
46	M11	Y	-.44	-4.74	0	13
47	M11	Y	-4.74	-6.57	13	26
48	M11	Y	-6.57	-4.05	26	39
49	M11	Y	-4.05	-.44	39	52
50	M12	Y	-1.76	-1.76		24



Company : Morrison Hershfield
 Designer : ML
 Job Number : GED-577R5 / 2000204
 Model Name : 75153-A /GOOD SAMARITAN

Dec 5, 2019
 3:00 PM
 Checked By: SWS

Member Distributed Loads (BLC 5 : BLC 3 Transient Area Loads) (Continued)

Member Label	Direction	Start Magnitude[lb/ft,F.psf]	End Magnitude[lb/ft,F.p...	Start Location[in,%]	End Location[in,%]	
51	M13	Y	-3.4	-3.4	.0004422	24
52	M14	Y	-45	-3.58	0	10.4
53	M14	Y	-3.58	-5.57	10.4	20.8
54	M14	Y	-5.57	-5.55	20.8	31.2
55	M14	Y	-5.55	-3.68	31.2	41.6
56	M14	Y	-3.68	-.82	41.6	52
57	M15	Y	-4.66	-2.48	5.2	14.56
58	M15	Y	-2.48	-2.73	14.56	23.92
59	M15	Y	-2.73	-3.92	23.92	33.28
60	M15	Y	-3.92	-2.24	33.28	42.64
61	M15	Y	-2.24	.03	42.64	52
62	M16	Y	-.15	-2.39	0	8.64
63	M16	Y	-2.39	-3.88	8.64	17.28
64	M16	Y	-3.88	-4.15	17.28	25.92
65	M16	Y	-4.15	-3.69	25.92	34.56
66	M16	Y	-3.69	-.2	34.56	43.2
67	M17	Y	-.46	-2.95	.02	10.01
68	M17	Y	-2.95	-4.2	10.01	20.01
69	M17	Y	-.42	-4.21	20.01	30
70	M17	Y	-4.21	-4.2	30	39.99
71	M17	Y	-.42	-2.95	39.99	49.99
72	M17	Y	-2.95	-.46	49.99	59.98
73	M18	Y	-.11	-2.74	0	8.64
74	M18	Y	-2.74	-4.76	8.64	17.28
75	M18	Y	-4.76	-7.01	17.28	25.92
76	M18	Y	-7.01	-4.45	25.92	34.56
77	M18	Y	-4.45	-.11	34.56	43.2
78	M19	Y	-3.23	-4.99	6	18
79	M19	Y	-4.99	-5.9	18	30
80	M19	Y	-5.9	-5.04	30	42
81	M19	Y	-5.04	-3.27	42	54
82	M20	Y	-1.01	-1.73	0	9.6
83	M20	Y	-1.73	-2.97	9.6	19.2
84	M20	Y	-2.97	-3.17	19.2	28.8
85	M20	Y	-3.17	-1.81	28.8	38.4
86	M20	Y	-1.81	-.44	38.4	48
87	M21	Y	-3.03	-2.57	0	25.54
88	M21	Y	-2.57	-1.87	25.54	51.08
89	M21	Y	-1.87	-.92	51.08	76.62
90	M21	Y	-.92	-.98	76.62	102.15
91	M21	Y	-.98	-.1	102.15	127.69
92	M21	Y	-.1	-.94	127.69	153.23
93	M21	Y	-.94	-1.45	153.23	178.77
94	M21	Y	-1.45	-.1	178.77	204.31
95	M21	Y	-.1	-.94	204.31	229.85
96	M21	Y	-.94	-1.22	229.85	255.38
97	M21	Y	-1.22	-1.1	255.38	280.92
98	M21	Y	-1.1	-1.45	280.92	306.46
99	M21	Y	-1.45	-2.04	306.46	332
100	M22	Y	-.62	-.45	0	25.54
101	M22	Y	-.45	-.45	25.54	51.08
102	M22	Y	-.45	-.54	51.08	76.62
103	M22	Y	-.54	-1.75	76.62	102.15
104	M22	Y	-1.75	-2.59	102.15	127.69
105	M22	Y	-2.59	-2.4	127.69	153.23
106	M22	Y	-2.4	-2.26	153.23	178.77
107	M22	Y	-2.26	-2.47	178.77	204.31



Company : Morrison Hershfield
 Designer : ML
 Job Number : GED-577R5 / 2000204
 Model Name : 75153-A /GOOD SAMARITAN

Dec 5, 2019
 3:00 PM
 Checked By: SWS

Member Distributed Loads (BLC 5 : BLC 3 Transient Area Loads) (Continued)

	Member Label	Direction	Start Magnitude[lb/ft,F.psf]	End Magnitude[lb/ft,F.p...	Start Location[in.%]	End Location[in.%]
108	M22	Y	-2.47	-2.49	204.31	229.85
109	M22	Y	-2.49	-.99	229.85	255.38
110	M22	Y	-.99	-1.55	255.38	280.92
111	M22	Y	-1.55	-2.79	280.92	306.46
112	M22	Y	-2.79	-2.18	306.46	332
113	M23	Y	-.15	-2.71	0	25.4
114	M23	Y	-2.71	-3.9	25.4	50.8
115	M23	Y	-3.9	-2.84	50.8	76.2
116	M23	Y	-2.84	-1.67	76.2	101.6
117	M23	Y	-1.67	-.62	101.6	127
118	M24	Y	-1.32	-1.44	12.7	33.02
119	M24	Y	-1.44	-2.5	33.02	53.34
120	M24	Y	-2.5	-5.2	53.34	73.66
121	M24	Y	-5.2	-4.9	73.66	93.98
122	M24	Y	-4.9	-.86	93.98	114.3
123	M41	Y	-.31	-3.42	0	9.6
124	M41	Y	-3.42	-4.99	9.6	19.2
125	M41	Y	-4.99	-6.05	19.2	28.8
126	M41	Y	-6.05	-4.5	28.8	38.4
127	M41	Y	-4.5	-.31	38.4	48
128	M42	Y	-.72	-1.8	0	9.6
129	M42	Y	-1.8	-2.55	9.6	19.2
130	M42	Y	-2.55	-2.56	19.2	28.8
131	M42	Y	-2.56	-1.79	28.8	38.4
132	M42	Y	-1.79	-.68	38.4	48

Member Distributed Loads (BLC 6 : BLC 2 Transient Area Loads)

	Member Label	Direction	Start Magnitude[lb/ft,F.psf]	End Magnitude[lb/ft,F.p...	Start Location[in.%]	End Location[in.%]
1	M1	Y	-41.44	-58.02	0	25.4
2	M1	Y	-58.02	-86.2	25.4	50.8
3	M1	Y	-86.2	-74.06	50.8	76.2
4	M1	Y	-74.06	-37.56	76.2	101.6
5	M1	Y	-37.56	-28.65	101.6	127
6	M2	Y	-57.28	-39.7	0	25.4
7	M2	Y	-39.7	-57.8	25.4	50.8
8	M2	Y	-57.8	-84.79	50.8	76.2
9	M2	Y	-84.79	-64.06	76.2	101.6
10	M2	Y	-64.06	-22.43	101.6	127
11	M3	Y	-28.21	-31.55	0	25.4
12	M3	Y	-31.55	-52.16	25.4	50.8
13	M3	Y	-52.16	-91.89	50.8	76.2
14	M3	Y	-91.89	-75.43	76.2	101.6
15	M3	Y	-75.43	-3.62	101.6	127
16	M4	Y	-28.26	-29.67	0	25.4
17	M4	Y	-29.67	-52.87	25.4	50.8
18	M4	Y	-52.87	-95.11	50.8	76.2
19	M4	Y	-95.11	-72.12	76.2	101.6
20	M4	Y	-72.12	-2.74	101.6	127
21	M5	Y	-28.57	-34.99	0	25.4
22	M5	Y	-34.99	-62.39	25.4	50.8
23	M5	Y	-62.39	-108.9	50.8	76.2
24	M5	Y	-108.9	-96.58	76.2	101.6
25	M5	Y	-96.58	-27.27	101.6	127
26	M6	Y	-44.02	-38.95	0	25.4
27	M6	Y	-38.95	-61.56	25.4	50.8
28	M6	Y	-61.56	-109.55	50.8	76.2



Company : Morrison Hershfield
 Designer : ML
 Job Number : GED-577R5 / 2000204
 Model Name : 75153-A /GOOD SAMARITAN

Dec 5, 2019
 3:00 PM
 Checked By: SWS

Member Distributed Loads (BLC 6 : BLC 2 Transient Area Loads) (Continued)

Member Label	Direction	Start Magnitude[lb/ft,F.psf]	End Magnitude[lb/ft,F.p...	Start Location[in,%]	End Location[in,%]
29	M6	Y	-109.55	-113.55	76.2 101.6
30	M6	Y	-113.55	-75.87	101.6 127
31	M7	Y	-3.52	-35.08	0 9.6
32	M7	Y	-35.08	-89.92	9.6 19.2
33	M7	Y	-89.92	-105.53	19.2 28.8
34	M7	Y	-105.53	-53.44	28.8 38.4
35	M7	Y	-53.44	-3.52	38.4 48
36	M8	Y	-27.8	-50.39	4.8 17.6
37	M8	Y	-50.39	-45.79	17.6 30.4
38	M8	Y	-45.79	-14	30.4 43.2
39	M9	Y	-14.58	-44.84	0 12
40	M9	Y	-44.84	-90.23	12 24
41	M9	Y	-90.23	-77.29	24 36
42	M9	Y	-77.29	-5.47	36 48
43	M10	Y	-14	-45.79	5.2 19.07
44	M10	Y	-45.79	-50.37	19.07 32.93
45	M10	Y	-50.37	-27.75	32.93 46.8
46	M11	Y	-6.65	-71.04	0 13
47	M11	Y	-71.04	-98.52	13 26
48	M11	Y	-98.52	-60.72	26 39
49	M11	Y	-60.72	-6.65	39 52
50	M12	Y	-26.4	-26.4	24 24
51	M13	Y	-51.02	-51.02	.0004422 24
52	M14	Y	-6.73	-53.74	0 10.4
53	M14	Y	-53.74	-83.48	10.4 20.8
54	M14	Y	-83.48	-83.2	20.8 31.2
55	M14	Y	-83.2	-55.2	31.2 41.6
56	M14	Y	-55.2	-12.25	41.6 52
57	M15	Y	-69.92	-37.17	5.2 14.56
58	M15	Y	-37.17	-40.98	14.56 23.92
59	M15	Y	-40.98	-58.84	23.92 33.28
60	M15	Y	-58.84	-33.59	33.28 42.64
61	M15	Y	-33.59	.52	42.64 52
62	M16	Y	-2.24	-35.91	0 8.64
63	M16	Y	-35.91	-58.21	8.64 17.28
64	M16	Y	-58.21	-62.27	17.28 25.92
65	M16	Y	-62.27	-55.34	25.92 34.56
66	M16	Y	-55.34	-30.01	34.56 43.2
67	M17	Y	-6.95	-44.3	.02 10.01
68	M17	Y	-44.3	-63.07	10.01 20.01
69	M17	Y	-63.07	-63.15	20.01 30
70	M17	Y	-63.15	-63.06	30 39.99
71	M17	Y	-63.06	-44.29	39.99 49.99
72	M17	Y	-44.29	-6.96	49.99 59.98
73	M18	Y	-1.6	-41.04	0 8.64
74	M18	Y	-41.04	-71.35	8.64 17.28
75	M18	Y	-71.35	-105.08	17.28 25.92
76	M18	Y	-105.08	-66.79	25.92 34.56
77	M18	Y	-66.79	-1.6	34.56 43.2
78	M19	Y	-48.39	-74.88	6 18
79	M19	Y	-74.88	-88.49	18 30
80	M19	Y	-88.49	-75.58	30 42
81	M19	Y	-75.58	-49.05	42 54
82	M20	Y	-15.21	-25.96	0 9.6
83	M20	Y	-25.96	-44.53	9.6 19.2
84	M20	Y	-44.53	-47.51	19.2 28.8
85	M20	Y	-47.51	-27.08	28.8 38.4



Company : Morrison Hershfield
 Designer : ML
 Job Number : GED-577R5 / 2000204
 Model Name : 75153-A /GOOD SAMARITAN

Dec 5, 2019
 3:00 PM
 Checked By: SWS

Member Distributed Loads (BLC 6 : BLC 2 Transient Area Loads) (Continued)

Member Label	Direction	Start Magnitude[lb/ft,F.psf]	End Magnitude[lb/ft,F.p...	Start Location[in,%]	End Location[in,%]	
86	M20	Y	-27.08	-6.64	38.4	48
87	M21	Y	-45.43	-38.61	0	25.54
88	M21	Y	-38.61	-28.02	25.54	51.08
89	M21	Y	-28.02	-13.8	51.08	76.62
90	M21	Y	-13.8	-14.68	76.62	102.15
91	M21	Y	-14.68	-14.97	102.15	127.69
92	M21	Y	-14.97	-14.09	127.69	153.23
93	M21	Y	-14.09	-21.8	153.23	178.77
94	M21	Y	-21.8	-15.04	178.77	204.31
95	M21	Y	-15.04	-14.11	204.31	229.85
96	M21	Y	-14.11	-18.26	229.85	255.38
97	M21	Y	-18.26	-16.47	255.38	280.92
98	M21	Y	-16.47	-21.72	280.92	306.46
99	M21	Y	-21.72	-30.54	306.46	332
100	M22	Y	-9.37	-6.73	0	25.54
101	M22	Y	-6.73	-6.73	25.54	51.08
102	M22	Y	-6.73	-8.08	51.08	76.62
103	M22	Y	-8.08	-26.32	76.62	102.15
104	M22	Y	-26.32	-38.79	102.15	127.69
105	M22	Y	-38.79	-36	127.69	153.23
106	M22	Y	-36	-33.92	153.23	178.77
107	M22	Y	-33.92	-37.02	178.77	204.31
108	M22	Y	-37.02	-37.35	204.31	229.85
109	M22	Y	-37.35	-14.83	229.85	255.38
110	M22	Y	-14.83	-23.22	255.38	280.92
111	M22	Y	-23.22	-41.78	280.92	306.46
112	M22	Y	-41.78	-32.72	306.46	332
113	M23	Y	-2.24	-40.63	0	25.4
114	M23	Y	-40.63	-58.46	25.4	50.8
115	M23	Y	-58.46	-42.67	50.8	76.2
116	M23	Y	-42.67	-25	76.2	101.6
117	M23	Y	-25	-9.25	101.6	127
118	M24	Y	-19.86	-21.61	12.7	33.02
119	M24	Y	-21.61	-37.43	33.02	53.34
120	M24	Y	-37.43	-78.06	53.34	73.66
121	M24	Y	-78.06	-73.47	73.66	93.98
122	M24	Y	-73.47	-12.92	93.98	114.3
123	M41	Y	-4.69	-51.25	0	9.6
124	M41	Y	-51.25	-74.79	9.6	19.2
125	M41	Y	-74.79	-90.68	19.2	28.8
126	M41	Y	-90.68	-67.5	28.8	38.4
127	M41	Y	-67.5	-4.69	38.4	48
128	M42	Y	-10.87	-26.97	0	9.6
129	M42	Y	-26.97	-38.32	9.6	19.2
130	M42	Y	-38.32	-38.43	19.2	28.8
131	M42	Y	-38.43	-26.87	28.8	38.4
132	M42	Y	-26.87	-10.15	38.4	48

Load Combinations

Description	S...P...	S...	BLC	Fa...	BLC	Fa...	BLC	Fa...	B...	Fa...	B...	Fa...	B...	Fa...	B...	Fa...	B...	Fa...	B...	Fa...
1 Seismic Mass	Y...	Y	DL	1																
2 IBC 16-5 (a)	Y...	Y	DL	1.2	Sds*	.2	SZ*SF	1	LL	.5	L...	1	SL	.2	S...	.7				
3 IBC 16-5 (b)	Y...	Y	DL	1.2	Sds*	.2	SZ*SF	1	LL	.5	L...	1	SL	.2	S...	.7				
4 IBC 16-5 (c)	Y...	Y	DL	1.2	Sds*	.2	SX*	-1	LL	.5	L...	1	SL	.2	S...	.7				
5 IBC 16-5 (d)	Y...	Y	DL	1.2	Sds*	.2	SZ*SF	-1	LL	.5	L...	1	SL	.2	S...	.7				



Company : Morrison Hershfield
 Designer : ML
 Job Number : GED-577R5 / 2000204
 Model Name : 75153-A /GOOD SAMARITAN

Dec 5, 2019
 3:00 PM
 Checked By: SWS

Load Combinations (Continued)

Description	S...	P...	S...	BLC	Fa...	BLC	Fa...	BLC	Fa...	B...	Fa...	B...	Fa...	B...	Fa...	B...	Fa...	B...	Fa...
6	IBC 16-7 (a)	Y...	Y	DL	.9	Sds*	-.2	SZ*SF	1										
7	IBC 16-7 (b)	Y...	Y	DL	.9	Sds*	-.2	SZ*SF	1										
8	IBC 16-7 (c)	Y...	Y	DL	.9	Sds*	-.2	SX*	-1										
9	IBC 16-7 (d)	Y...	Y	DL	.9	Sds*	-.2	SZ*SF	-1										
10	IBC 16-5 (os-a)	Y...	Y	DL	1.2	Sds*	.2	Om*	1	LL	.5	L...	1	SL	.2	S...	.7		
11	IBC 16-5 (os-b)	Y...	Y	DL	1.2	Sds*	.2	Om*	1	LL	.5	L...	1	SL	.2	S...	.7		
12	IBC 16-5 (os-c)	Y...	Y	DL	1.2	Sds*	.2	Om*	-1	LL	.5	L...	1	SL	.2	S...	.7		
13	IBC 16-5 (os-d)	Y...	Y	DL	1.2	Sds*	.2	Om*	-1	LL	.5	L...	1	SL	.2	S...	.7		
14	IBC 16-7 (os-a)	Y...	Y	DL	.9	Sds*	-.2	Om*	1										
15	IBC 16-7 (os-b)	Y...	Y	DL	.9	Sds*	-.2	Om*	1										
16	IBC 16-7 (os-c)	Y...	Y	DL	.9	Sds*	-.2	Om*	-1										
17	IBC 16-7 (os-d)	Y...	Y	DL	.9	Sds*	-.2	Om*	-1										

Envelope Joint Reactions

Joint		X [lb]	LC	Y [lb]	LC	Z [lb]	LC	MX [lb-ft]	LC	MY [lb-ft]	LC	MZ [lb-ft]	LC	
1	N5	max	1065.136	4	6796.959	5	1207.649	9	0	9	0	9	0	9
2		min	-121.567	6	2891.015	6	-1207.657	2	0	1	0	1	0	1
3	N7	max	1027.863	8	6393.724	5	1207.65	9	0	9	0	9	0	9
4		min	-162.584	2	2670.109	6	-1207.655	2	0	1	0	1	0	1
5	N6	max	1065.124	4	5887.39	5	861.389	5	0	9	0	9	0	9
6		min	-121.572	6	2391.949	6	-861.383	6	0	1	0	1	0	1
7	N8	max	1027.857	8	5465.924	5	861.389	5	0	9	0	9	0	9
8		min	-162.595	2	2181.465	6	-861.381	6	0	1	0	1	0	1
9	Totals:	max	4185.969	8	24543.997	5	4138.073	5						
10		min	-568.309	2	10134.538	6	-4138.073	6						

Envelope AISC 15th(360-16): LRFD Steel Code Checks

Member	Shape	Code Che...	Loc[in]	LC	Shear Check	Loc[in]	Dir	LC	phi*Pn...	phi*...	phi*...	phi*...	Eqn	
1	M1	W8X13	.142	96.573	3	.044	127	y	5	38237...	172...	806...	269...	H1...
2	M2	W8X13	.123	0	3	.019	121.708	z	3	38237...	172...	806...	233...	H1...
3	M3	W8X13	.232	42.333	3	.050	0	y	3	38237...	172...	806...	284...	H1...
4	M4	W8X13	.219	42.333	4	.050	0	y	3	38237...	172...	806...	285...	H1...
5	M5	W8X13	.094	0	3	.014	47.625	z	4	38237...	172...	806...	250...	H1...
6	M6	W8X13	.097	48.948	3	.018	0	y	3	38237...	172...	806...	271...	H1...
7	M7	W8X13	.012	21.5	4	.013	48	y	5	13634...	172...	806...	410...	H1...
8	M8	W8X13	.002	23.5	3	.002	0	y	5	13634...	172...	806...	42750...	H1...
9	M9	W8X13	.002	24.5	3	.002	48	y	5	13634...	172...	806...	42750...	H1...
10	M10	W8X13	.005	0	7	.005	52	y	3	13084...	172...	806...	42750...	H1...
11	M11	W8X13	.002	26	3	.003	0	y	3	13084...	172...	806...	42750...	H1...
12	M12	W8X13	.002	12	4	.001	24	y	5	16286...	172...	806...	42750...	H1...
13	M13	W8X13	.008	0	3	.001	24	y	5	16286...	172...	806...	42750...	H1...
14	M14	W8X13	.005	26	4	.003	52	y	5	13084...	172...	806...	42750...	H1...
15	M15	W8X13	.007	0	7	.005	0	y	5	13084...	172...	806...	42750...	H1...
16	M16	W8X13	.004	0	7	.002	0	y	3	13634...	172...	806...	42750...	H1...
17	M17	W8X13	.011	30	4	.010	0	y	5	11932...	172...	806...	386...	H1...
18	M18	W8X13	.004	24	4	.002	0	y	3	13634...	172...	806...	42750...	H1...
19	M19	W8X13	.014	30	4	.010	60	y	5	11932...	172...	806...	388...	H1...
20	M20	W8X13	.013	19.5	3	.015	48	y	5	13634...	172...	806...	408...	H1...
21	M21	W16X26	.144	166	3	.112	166	y	3	78609.9	345...	20550	165...	H1...
22	M22	W16X26	.140	166	3	.084	166	y	5	78609.9	345...	20550	165...	H1...
23	M23	W10X15	.057	63.5	4	.011	127	y	5	10533...	198...	8625	60000...	H1...
24	M24	W10X15	.103	63.5	4	.016	48.948	z	4	10533...	198...	8625	60000...	H1...
25	M25	HSS4.000X0.226	.228	18	3	.043	0		5	93461...	94500	9513	9513	H1...
26	M26	HSS4.000X0.226	.226	18	3	.043	0		5	93461...	94500	9513	9513	H1...



Company : Morrison Hershfield
 Designer : ML
 Job Number : GED-577R5 / 2000204
 Model Name : 75153-A /GOOD SAMARITAN

Dec 5, 2019
 3:00 PM
 Checked By: SWS

Envelope AISC 15th(360-16): LRFD Steel Code Checks (Continued)

Member	Shape	Code Che...	Loc[in]	LC	Shear Check	Loc[in]	Dir	LC	phi*Pn...	phi*...	phi*...	phi*...	Eqn
27	M27	HSS4.000X0.226	.198	18	4	.038	0	4	93461...	94500	9513	9513	...H1-...
28	M28	HSS4.000X0.226	.189	18	4	.036	0	8	93461...	94500	9513	9513	...H1-...
29	M41	C6X8.2	.025	24	3	.010	48	y	59853...	107...	292...	19350...	H1-...
30	M42	C6X8.2	.031	24	3	.011	0	y	59853...	107...	292...	19350...	H1-...

Mode Shape 1

Joint Label	X Translation	Y Translation	Z Translation	X Rotation	Y Rotation	Z Rotation
N1	.137	-.005	1.454	0	.002	0
N2	.137	-.005	.682	0	.002	0
N3	-.158	.005	1.454	0	.002	0
N4	-.158	.005	.682	0	.002	0
N5	0.000	0.000	0.000	.112	.002	-.011
N6	0.000	0.000	0.000	.053	.002	-.011
N7	0.000	0.000	0.000	.112	.002	.012
N8	0.000	0.000	0.000	.053	.002	.012
N9	.142	-.005	10.603	0	-.09	0
N10	-.16	.005	10.641	0	-.09	0
N11	.149	-.005	9.447	0	.099	0
N12	-.171	.005	9.461	0	.1	0
N13	.143	-.005	2.088	0	.091	0
N14	-.162	.005	2.093	0	.098	0
N15	.136	-.005	1.059	0	.003	0
N16	-.158	.005	1.064	0	0	0
N17	.13	-.005	1.357	0	0	0
N18	-.158	.005	1.357	0	-.005	0
N19	.131	-.005	1.351	0	.01	0
N20	-.158	.005	1.353	0	.006	0
N21	-.218	-.004	.682	0	.012	0
N22	-.307	-.003	10.612	0	.013	0
N23	-.313	-.004	9.451	0	-.005	0
N24	-.291	-.004	2.092	0	-.003	0
N25	-.268	-.004	1.062	0	.018	0
N26	-.236	-.004	1.357	0	.018	0
N27	-.223	-.004	1.352	0	.015	0
N28	-.153	-.001	.682	0	-.012	0
N29	-.21	-.001	10.623	0	-.015	0
N30	-.208	-.002	9.455	0	-.009	0
N31	-.21	-.003	2.094	0	-.014	0
N32	-.213	-.003	1.064	0	-.009	0
N33	-.162	-.001	1.358	0	-.007	0
N34	-.159	-.002	1.353	0	-.008	0
N35	-.214	-.002	1.358	0	-.009	0
N36	.608	.002	1.454	0	-.019	0
N37	.614	.003	10.644	0	-.012	0
N38	.137	-.005	1.459	0	.002	0
N39	.137	-.005	.688	0	.002	0
N40	-.158	.005	1.459	0	.002	0
N41	-.158	.005	.688	0	.002	0
N42	.137	-.005	1.074	0	.002	0
N43	.137	-.005	1.456	0	.002	0
N44	.137	-.005	1.071	0	.002	0
N45	.137	-.005	.685	0	.002	0
N46	.137	-.005	1.07	0	.002	0
N47	-.01	0	1.459	0	.002	0
N48	-.01	0	1.456	0	.002	0
N49	-.158	.005	1.456	0	.002	0



Company : Morrison Hershfield
 Designer : ML
 Job Number : GED-577R5 / 2000204
 Model Name : 75153-A /GOOD SAMARITAN

Dec 5, 2019
 3:00 PM
 Checked By: SWS

Mode Shape 1, (continued)

Joint Label	X Translation	Y Translation	Z Translation	X Rotation	Y Rotation	Z Rotation
N50	-.01	0	1.454	0	.002	0
N51	-.158	.005	1.074	0	.002	0
N52	-.158	.005	1.071	0	.002	0
N53	-.158	.005	.685	0	.002	0
N54	-.158	.005	1.069	0	.002	0
N55	-.01	0	.688	0	.002	0
N56	-.01	0	.685	0	.002	0
N57	-.01	0	.682	0	.002	0
N58	-.01	0	1.071	0	0.000	0
N59	.137	-.005	1.148	0	.002	0
N60	.137	-.005	1.373	0	.002	0
N61	.137	-.005	1.206	0	.002	0
N62	.137	-.005	1.038	0	.002	0
N63	.137	-.005	.871	0	.002	0
N64	.137	-.005	.736	0	.002	0
N65	.019	-.001	.685	0	.002	0
N66	.054	-.002	.685	0	.002	0
N67	-.093	.003	.685	0	.002	0
N68	.626	.002	9.46	0	-.011	0
N69	.673	.003	10.645	0	-.005	0
N70	.678	.003	9.461	0	-.006	0
N71	.195	.005	10.644	0	.051	0
N72	.25	.005	9.461	0	.055	0
N73	.18	.005	1.454	0	.05	0

Mode Shape 2

Joint Label	X Translation	Y Translation	Z Translation	X Rotation	Y Rotation	Z Rotation
N1	.014	-.005	.585	0	-.003	0
N2	.014	-.006	1.694	0	-.003	0
N3	.438	.006	.585	0	-.003	0
N4	.438	.005	1.694	0	-.003	0
N5	0.000	0.000	0.000	.045	-.003	-.001
N6	0.000	0.000	0.000	.131	-.003	-.001
N7	0.000	0.000	0.000	.045	-.003	-.034
N8	0.000	0.000	0.000	.131	-.003	-.034
N9	.016	-.005	-1.574	0	.02	0
N10	.439	.007	-1.58	0	.018	0
N11	.017	-.006	-1.088	0	-.034	0
N12	.443	.007	-1.089	0	-.027	0
N13	.016	-.006	.877	0	-.027	0
N14	.439	.006	.874	0	-.025	0
N15	.012	-.006	1.344	0	-.058	0
N16	.438	.006	1.333	0	-.055	0
N17	.003	-.006	10.13	0	-.149	0
N18	.44	.005	10.145	0	-.177	0
N19	.015	-.006	14.634	0	.019	0
N20	.439	.005	14.621	0	.044	0
N21	.567	-.005	1.695	0	-.019	0
N22	.567	-.003	-1.575	0	-.019	0
N23	.573	-.004	-1.089	0	-.02	0
N24	.586	-.005	.879	0	-.022	0
N25	.596	-.005	1.346	0	-.015	0
N26	.61	-.005	10.135	0	.006	0
N27	.572	-.005	14.644	0	-.032	0
N28	.457	-.002	1.695	0	.02	0
N29	.649	0	-1.578	0	.006	0
N30	.648	-.001	-1.089	0	.006	0



Company : Morrison Hershfield
 Designer : ML
 Job Number : GED-577R5 / 2000204
 Model Name : 75153-A /GOOD SAMARITAN

Dec 5, 2019
 3:00 PM
 Checked By: SWS

Mode Shape 2. (continued)

Joint Label	X Translation	Y Translation	Z Translation	X Rotation	Y Rotation	Z Rotation
N31	.643	-.004	.88	0	.009	0
N32	.638	-.004	1.346	0	.011	0
N33	.466	-.002	10.14	0	.035	0
N34	.467	-.002	14.649	0	.009	0
N35	.626	-.002	10.139	0	.017	0
N36	.265	.003	.585	0	0	0
N37	.265	.004	-1.582	0	.004	0
N38	.014	-.005	.592	0	-.003	0
N39	.014	-.006	1.7	0	-.003	0
N40	.438	.006	.592	0	-.003	0
N41	.438	.005	1.7	0	-.003	0
N42	.014	-.006	1.146	0	-.003	0
N43	.014	-.005	.588	0	-.003	0
N44	.014	-.006	1.143	0	-.003	0
N45	.014	-.006	1.697	0	-.003	0
N46	.014	-.006	1.142	0	-.003	0
N47	.226	0	.592	0	-.003	0
N48	.226	0	.588	0	-.003	0
N49	.438	.006	.588	0	-.003	0
N50	.226	0	.585	0	-.003	0
N51	.438	.006	1.146	0	-.003	0
N52	.438	.006	1.143	0	-.003	0
N53	.438	.005	1.697	0	-.003	0
N54	.438	.006	1.141	0	-.003	0
N55	.226	0	1.7	0	-.003	0
N56	.226	0	1.697	0	-.003	0
N57	.226	0	1.694	0	-.003	0
N58	.226	0	1.143	0	0.000	0
N59	.014	-.006	1.032	0	-.003	0
N60	.014	-.005	.709	0	-.003	0
N61	.014	-.006	.949	0	-.003	0
N62	.014	-.006	1.19	0	-.003	0
N63	.014	-.006	1.43	0	-.003	0
N64	.014	-.006	1.624	0	-.003	0
N65	.183	-.002	1.697	0	-.003	0
N66	.134	-.003	1.697	0	-.003	0
N67	.344	.003	1.697	0	-.003	0
N68	.27	.003	-1.09	0	.005	0
N69	.246	.005	-1.582	0	.002	0
N70	.245	.004	-1.09	0	.003	0
N71	.354	.006	-1.581	0	-.012	0
N72	.335	.006	-1.09	0	-.014	0
N73	.361	.006	.585	0	-.011	0

Mode Shape 3

Joint Label	X Translation	Y Translation	Z Translation	X Rotation	Y Rotation	Z Rotation
N1	3.812	.009	.021	0	.001	0
N2	3.812	-.007	-.365	0	.001	0
N3	3.664	.007	.021	0	.001	0
N4	3.664	-.009	-.365	0	.001	0
N5	0.000	0.000	0.000	.002	.001	-.294
N6	0.000	0.000	0.000	-.028	.001	-.294
N7	0.000	0.000	0.000	.002	.001	-.282
N8	0.000	0.000	0.000	-.028	.001	-.282
N9	3.82	.007	.332	0	.006	0
N10	3.681	.006	.349	0	-.005	0
N11	3.827	.005	-.04	0	-.009	0



Company : Morrison Hershfield
 Designer : ML
 Job Number : GED-577R5 / 2000204
 Model Name : 75153-A /GOOD SAMARITAN

Dec 5, 2019
 3:00 PM
 Checked By: SWS

Mode Shape 3, (continued)

Joint Label	X Translation	Y Translation	Z Translation	X Rotation	Y Rotation	Z Rotation
N12	3.695	.004	-.035	0	.032	0
N13	3.819	.002	-.238	0	-.012	0
N14	3.673	0	-.235	0	-.004	0
N15	3.816	0	-.175	0	-.003	0
N16	3.665	-.001	-.198	0	.008	0
N17	3.829	-.003	-1	0	0	0
N18	3.669	-.005	-.997	0	.012	0
N19	3.829	-.005	-1.166	0	-.022	0
N20	3.669	-.007	-1.174	0	-.002	0
N21	5.055	-.007	-.365	0	-.071	0
N22	4.99	.009	.335	0	-.063	0
N23	4.986	.005	-.039	0	-.077	0
N24	5.008	.004	-.238	0	-.08	0
N25	5.013	0	-.179	0	-.082	0
N26	5.015	-.003	-1	0	-.093	0
N27	5.023	-.006	-1.169	0	-.066	0
N28	5.474	-.007	-.365	0	.107	0
N29	6.222	.01	.339	0	-.032	0
N30	6.223	.005	-.038	0	-.032	0
N31	6.217	.005	-.238	0	-.017	0
N32	6.194	0	-.184	0	-.017	0
N33	5.666	-.004	-.999	0	.072	0
N34	5.589	-.007	-1.171	0	.013	0
N35	6.102	-.003	-1	0	.045	0
N36	5.875	.007	.021	0	-.041	0
N37	5.906	.01	.346	0	.03	0
N38	3.815	.009	.02	0	.001	0
N39	3.815	-.007	-.366	0	.001	0
N40	3.668	.007	.02	0	.001	0
N41	3.668	-.009	-.366	0	.001	0
N42	3.815	0	-.173	0	.001	0
N43	3.814	.009	.021	0	.001	0
N44	3.814	0	-.172	0	.001	0
N45	3.814	-.007	-.365	0	.001	0
N46	3.812	0	-.172	0	.001	0
N47	3.742	.008	.02	0	.001	0
N48	3.74	.008	.021	0	.001	0
N49	3.666	.007	.021	0	.001	0
N50	3.739	.008	.021	0	.001	0
N51	3.668	0	-.173	0	.001	0
N52	3.666	0	-.172	0	.001	0
N53	3.666	-.009	-.365	0	.001	0
N54	3.665	0	-.172	0	.001	0
N55	3.742	-.008	-.366	0	.001	0
N56	3.74	-.008	-.365	0	.001	0
N57	3.74	-.008	-.365	0	.001	0
N58	3.74	0	-.172	0	0.000	0
N59	3.814	.002	-.134	0	.001	0
N60	3.814	.007	-.021	0	.001	0
N61	3.814	.004	-.105	0	.001	0
N62	3.814	0	-.189	0	.001	0
N63	3.814	-.003	-.272	0	.001	0
N64	3.814	-.006	-.34	0	.001	0
N65	3.755	-.007	-.365	0	.001	0
N66	3.772	-.007	-.365	0	.001	0
N67	3.699	-.008	-.365	0	.001	0
N68	6.027	.005	-.036	0	.046	0
N69	5.714	.01	.346	0	.04	0



Company : Morrison Hershfield
 Designer : ML
 Job Number : GED-577R5 / 2000204
 Model Name : 75153-A /GOOD SAMARITAN

Dec 5, 2019
 3:00 PM
 Checked By: SWS

Mode Shape 3, (continued)

Joint Label	X Translation	Y Translation	Z Translation	X Rotation	Y Rotation	Z Rotation
N70	5.719	.005	-.036	0	.057	0
N71	4.16	.007	.349	0	.079	0
N72	4.072	.004	-.035	0	.07	0
N73	4.193	.007	.021	0	.092	0

Mode Shape 4

Joint Label	X Translation	Y Translation	Z Translation	X Rotation	Y Rotation	Z Rotation
N1	.002	-.056	.01	0	0	0
N2	.002	-.04	.009	0	0	0
N3	.001	-.03	.01	0	0	0
N4	.001	-.014	.009	0	0	0
N5	0.000	0.000	0.000	0	0	0
N6	0.000	0.000	0.000	0	0	0
N7	0.000	0.000	0.000	0	0	0
N8	0.000	0.000	0.000	0	0	0
N9	.002	-.901	-.006	-.002	0	-.013
N10	.001	-.612	-.006	.006	0	-.008
N11	.002	-1.25	-.003	-.004	0	.001
N12	.001	-.743	-.003	.013	0	.003
N13	.002	-.669	.009	-.42	0	.023
N14	.001	-.324	.009	.32	0	.012
N15	.002	.095	.009	.04	0	.022
N16	.001	.05	.009	-.031	0	.011
N17	.002	.763	-.004	0	0	.005
N18	.001	.395	-.004	-.005	0	-.003
N19	.002	.67	-.012	.008	0	-.007
N20	.001	.349	-.012	-.011	0	-.004
N21	.003	-.037	.009	0	0	0
N22	.003	-1.224	-.006	-.016	0	-.012
N23	.003	-1.326	-.003	-.003	0	.001
N24	.003	-8.287	.009	-.362	0	.022
N25	.003	.831	.009	.035	0	.021
N26	.003	.761	-.004	0	0	.004
N27	.003	.817	-.012	.007	0	-.007
N28	.003	-.031	.009	0	0	0
N29	.004	-1.561	-.006	-.01	0	-.011
N30	.004	-1.371	-.003	0	0	.002
N31	.004	-14.943	.009	-.151	0	.02
N32	.004	1.472	.009	.014	0	.019
N33	.003	.723	-.004	-.002	0	.004
N34	.003	.931	-.012	0	0	-.006
N35	.004	.735	-.004	-.002	0	.004
N36	.001	-.038	.01	0	0	0
N37	.001	-1.512	-.006	.015	0	-.009
N38	-.002	-.056	.024	0	0	0
N39	-.002	-.04	.023	0	0	0
N40	-.002	-.03	.024	0	0	0
N41	-.002	-.014	.023	0	0	0
N42	-.002	-.048	.024	0	0	0
N43	0	-.056	.017	0	0	0
N44	0	-.048	.016	0	0	0
N45	0	-.04	.016	0	0	0
N46	.002	-.048	.009	0	0	.024
N47	-.002	-.043	.024	0	0	0
N48	0	-.043	.017	0	0	0
N49	0	-.03	.017	0	0	0
N50	.002	-.043	.01	0	0	0



Company : Morrison Hershfield
 Designer : ML
 Job Number : GED-577R5 / 2000204
 Model Name : 75153-A /GOOD SAMARITAN

Dec 5, 2019
 3:00 PM
 Checked By: SWS

Mode Shape 4, (continued)

Joint Label	X Translation	Y Translation	Z Translation	X Rotation	Y Rotation	Z Rotation
N51	-.002	-.022	.024	0	0	0
N52	0	-.022	.016	0	0	0
N53	0	-.014	.016	0	0	0
N54	.001	-.022	.009	0	0	.012
N55	-.002	-.027	.023	0	0	0
N56	0	-.027	.016	0	0	0
N57	.002	-.027	.009	0	0	0
N58	0	-.035	.016	0	0.000	0
N59	0	-.05	.016	0	0	0
N60	0	-.054	.017	0	0	0
N61	0	-.051	.017	0	0	0
N62	0	-.047	.016	0	0	0
N63	0	-.044	.016	0	0	0
N64	0	-.041	.016	0	0	0
N65	0	-.03	.016	0	0	0
N66	0	-.033	.016	0	0	0
N67	0	-.02	.016	0	0	0
N68	.001	-1.153	-.003	.009	0	.002
N69	0	-1.408	-.006	.019	0	-.009
N70	0	-1.098	-.003	.01	0	.002
N71	0	-.796	-.006	.028	0	-.008
N72	0	-.821	-.003	.012	0	.002
N73	.001	-.031	.01	0	0	0

Mode Shape 5

Joint Label	X Translation	Y Translation	Z Translation	X Rotation	Y Rotation	Z Rotation
N1	0	.06	-.016	0	0	0
N2	0	.063	-.015	0	0	0
N3	0	.02	-.016	0	0	0
N4	0	.024	-.015	0	0	0
N5	0.000	0.000	0.000	-.001	0	0
N6	0.000	0.000	0.000	-.001	0	0
N7	0.000	0.000	0.000	-.001	0	0
N8	0.000	0.000	0.000	-.001	0	0
N9	0	-.071	.011	0	0	-.002
N10	0	-.056	.011	0	0	-.001
N11	0	-.122	.004	0	0	0
N12	0	-.076	.004	0	0	0
N13	0	-.014	-.015	.046	0	.004
N14	0	-.014	-.015	-.034	0	.002
N15	0	.167	-.016	.439	0	.007
N16	0	.063	-.015	-.33	0	.003
N17	0	.38	.006	.001	0	.001
N18	0	.158	.006	-.004	0	0
N19	0	.337	.019	.004	0	-.003
N20	0	.142	.019	-.006	0	-.001
N21	0	.059	-.015	0	0	0
N22	-.001	-.104	.011	-.002	0	-.002
N23	-.001	-.126	.004	0	0	0
N24	-.001	.812	-.015	.039	0	.004
N25	-.001	8.138	-.016	.38	0	.006
N26	0	.398	.006	0	0	.001
N27	0	.41	.019	.003	0	-.003
N28	-.001	.049	-.015	0	0	0
N29	-.001	-.138	.011	-.001	0	-.002
N30	-.001	-.128	.004	0	0	0
N31	-.001	1.54	-.015	.017	0	.004



Company : Morrison Hershfield
Designer : ML
Job Number : GED-577R5 / 2000204
Model Name : 75153-A /GOOD SAMARITAN

Dec 5, 2019
3:00 PM
Checked By: SWS

Mode Shape 5, (continued)

Joint Label	X Translation	Y Translation	Z Translation	X Rotation	Y Rotation	Z Rotation
N32	-.001	15.145	-.016	.159	0	.006
N33	-.001	.393	.006	-.001	0	.001
N34	-.001	.464	.019	0	0	-.002
N35	-.001	.398	.006	0	0	.001
N36	.003	.032	-.016	0	0	0
N37	.003	-.139	.011	.001	0	-.001
N38	-.001	.06	-.039	0	0	0
N39	-.001	.063	-.038	0	0	0
N40	-.001	.02	-.039	0	0	0
N41	-.001	.024	-.038	0	0	0
N42	-.001	.062	-.038	0	0	0
N43	-.001	.06	-.027	0	0	0
N44	-.001	.062	-.027	0	0	0
N45	-.001	.063	-.026	0	0	0
N46	0	.062	-.016	0	0	.007
N47	-.001	.04	-.039	0	0	0
N48	0	.04	-.027	0	0	0
N49	0	.02	-.027	0	0	0
N50	0	.04	-.016	0	0	0
N51	-.001	.022	-.038	0	0	0
N52	0	.022	-.027	0	0	0
N53	0	.024	-.026	0	0	0
N54	0	.022	-.015	0	0	.003
N55	-.001	.044	-.038	0	0	0
N56	0	.044	-.026	0	0	0
N57	0	.044	-.015	0	0	0
N58	0	.042	-.027	0	0.000	0
N59	-.001	.061	-.027	0	0	0
N60	-.001	.06	-.027	0	0	0
N61	-.001	.061	-.027	0	0	0
N62	-.001	.062	-.027	0	0	0
N63	-.001	.062	-.027	0	0	0
N64	-.001	.063	-.026	0	0	0
N65	0	.047	-.026	0	0	0
N66	-.001	.052	-.026	0	0	0
N67	0	.032	-.026	0	0	0
N68	.003	-.109	.004	0	0	0
N69	.003	-.129	.011	.002	0	-.001
N70	.003	-.104	.004	0	0	0
N71	.001	-.073	.011	.003	0	-.001
N72	.001	-.082	.004	0	0	0
N73	0	.023	-.016	0	0	0

Mode Shape 6

Joint Label	X Translation	Y Translation	Z Translation	X Rotation	Y Rotation	Z Rotation
N1	.025	.05	.532	0	0	0
N2	.025	-.029	.479	0	0	0
N3	.005	.119	.532	0	0	0
N4	.005	.04	.479	0	0	0
N5	0.000	0.000	0.000	.041	0	-.002
N6	0.000	0.000	0.000	.037	0	-.002
N7	0.000	0.000	0.000	.041	0	0
N8	0.000	0.000	0.000	.037	0	0
N9	.024	1.392	-.281	.031	.004	.014
N10	.005	4.632	-.287	-.008	.005	.049
N11	.024	1.334	.056	.061	-.01	-.012
N12	.005	4.547	.056	-.017	-.012	-.037



Company : Morrison Hershfield
 Designer : ML
 Job Number : GED-577R5 / 2000204
 Model Name : 75153-A /GOOD SAMARITAN

Dec 5, 2019
 3:00 PM
 Checked By: SWS

Mode Shape 6, (continued)

Joint Label	X Translation	Y Translation	Z Translation	X Rotation	Y Rotation	Z Rotation
N13	.025	.335	.549	-.058	0	-.019
N14	.005	1.257	.54	.057	0	-.063
N15	.025	-.084	.506	.013	.002	-.015
N16	.005	-.227	.502	-.012	.002	-.049
N17	.027	-.662	-.003	-.015	.009	-.006
N18	.005	-1.761	-.004	-.003	.012	-.011
N19	.026	-.68	-.368	-.045	-.001	.005
N20	.005	-1.568	-.367	.023	-.002	.016
N21	.041	-.019	.48	0	0	0
N22	.051	7.896	-.282	.336	-.001	.019
N23	.051	2.441	.056	.058	.001	-.015
N24	.046	-.716	.553	-.049	-.001	-.025
N25	.043	.153	.51	.011	-.001	-.02
N26	.039	-.936	-.003	-.014	-.003	-.007
N27	.04	-1.485	-.369	-.04	0	.007
N28	.045	-.003	.48	0	.002	0
N29	.048	15.066	-.284	.232	.002	.025
N30	.049	3.714	.056	.045	.001	-.02
N31	.05	-1.592	.553	-.017	0	-.033
N32	.051	.354	.511	.004	0	-.027
N33	.049	-1.317	-.003	-.01	0	-.008
N34	.047	-2.391	-.369	-.017	0	.009
N35	.05	-1.252	-.003	-.011	0	-.008
N36	-.147	.105	.533	0	.004	0
N37	-.148	17.469	-.288	-.188	.002	.039
N38	.042	.05	.571	0	0	0
N39	.042	-.029	.518	0	0	0
N40	.022	.119	.571	0	0	0
N41	.022	.04	.518	0	0	0
N42	.042	.011	.544	0	0	0
N43	.034	.05	.551	0	0	0
N44	.034	.011	.525	0	0	0
N45	.034	-.029	.499	0	0	0
N46	.025	.011	.507	0	0	-.016
N47	.032	.085	.571	0	0	0
N48	.024	.085	.551	0	0	0
N49	.014	.119	.551	0	0	0
N50	.015	.085	.532	0	0	0
N51	.022	.08	.544	0	0	0
N52	.014	.08	.525	0	0	0
N53	.014	.04	.499	0	0	0
N54	.005	.08	.506	0	0	-.054
N55	.032	.006	.518	0	0	0
N56	.024	.006	.499	0	0	0
N57	.015	.006	.479	0	0	0
N58	.024	.045	.525	0	0.000	0
N59	.034	.019	.53	0	0	0
N60	.034	.042	.546	0	0	0
N61	.034	.025	.534	0	0	0
N62	.034	-.008	.523	0	0	0
N63	.034	-.01	.511	0	0	0
N64	.034	-.023	.502	0	0	0
N65	.026	-.001	.499	0	0	0
N66	.028	-.009	.499	0	0	0
N67	.018	.025	.499	0	0	0
N68	-.15	4.947	.056	.004	.002	-.03
N69	-.156	16.107	-.288	-.252	0	.04
N70	-.156	4.952	.056	-.002	0	-.031



Company : Morrison Hershfield
 Designer : ML
 Job Number : GED-577R5 / 2000204
 Model Name : 75153-A /GOOD SAMARITAN

Dec 5, 2019
 3:00 PM
 Checked By: SWS

Mode Shape 6. (continued)

Joint Label	X Translation	Y Translation	Z Translation	X Rotation	Y Rotation	Z Rotation
N71	-.052	7.317	-.288	-.412	-.009	.047
N72	-.055	4.666	.056	-.016	-.009	-.035
N73	-.051	.118	.532	0	-.009	0

Mode Shape 7

Joint Label	X Translation	Y Translation	Z Translation	X Rotation	Y Rotation	Z Rotation
N1	.292	-.041	5.838	0	.002	0
N2	.292	-.035	5.221	0	.002	0
N3	.056	.027	5.838	0	.002	0
N4	.056	.033	5.221	0	.002	0
N5	0.000	0.000	0.000	.45	.002	-.023
N6	0.000	0.000	0.000	.402	.002	-.023
N7	0.000	0.000	0.000	.45	.002	-.004
N8	0.000	0.000	0.000	.402	.002	-.004
N9	.285	-.167	-3.06	-.002	.046	-.001
N10	.054	-.388	-3.13	.001	.05	-.004
N11	.278	-.161	.707	-.005	-.114	.001
N12	.061	-.379	.709	.002	-.132	.003
N13	.29	-.067	6.038	.007	-.003	.002
N14	.058	-.077	5.944	-.006	-.001	.006
N15	.295	-.03	5.534	.001	.017	.001
N16	.056	.059	5.493	0	.023	.005
N17	.311	.018	.027	.002	.102	0
N18	.055	.202	.024	.001	.127	.001
N19	.303	.017	-3.95	.004	-.012	0
N20	.056	.185	-3.942	0	-.017	-.001
N21	.51	-.026	5.229	0	-.013	0
N22	.621	-.768	-3.076	-.031	-.015	-.002
N23	.618	-.252	.708	-.005	.01	.001
N24	.564	.067	6.081	.006	-.015	.002
N25	.539	-.006	5.58	.001	-.019	.002
N26	.493	.053	.027	.002	-.04	0
N27	.502	.092	-3.96	.004	-.009	0
N28	.576	-.01	5.229	0	.024	0
N29	.635	-1.428	-3.096	-.021	.023	-.002
N30	.641	-.355	.709	-.003	.016	.002
N31	.661	.187	6.091	.003	.003	.003
N32	.665	.023	5.597	0	0	.002
N33	.62	.106	.026	.002	0	0
N34	.602	.184	-3.966	.002	.005	0
N35	.657	.096	.026	.002	.008	0
N36	-1.598	.008	5.849	0	.047	0
N37	-1.615	-1.62	-3.134	.018	.024	-.004
N38	.291	-.041	5.876	0	.002	0
N39	.291	-.035	5.26	0	.002	0
N40	.055	.027	5.876	0	.002	0
N41	.055	.033	5.26	0	.002	0
N42	.291	-.038	5.568	0	.002	0
N43	.292	-.041	5.857	0	.002	0
N44	.292	-.038	5.549	0	.002	0
N45	.292	-.035	5.241	0	.002	0
N46	.292	-.038	5.54	0	.002	.001
N47	.173	-.007	5.876	0	.002	0
N48	.174	-.007	5.857	0	.002	0
N49	.056	.027	5.857	0	.002	0
N50	.174	-.007	5.838	0	.002	0
N51	.055	.03	5.568	0	.002	0



Company : Morrison Hershfield
 Designer : ML
 Job Number : GED-577R5 / 2000204
 Model Name : 75153-A /GOOD SAMARITAN

Dec 5, 2019
 3:00 PM
 Checked By: SWS

Mode Shape 7. (continued)

Joint Label	X Translation	Y Translation	Z Translation	X Rotation	Y Rotation	Z Rotation
N52	.056	.03	5.549	0	.002	0
N53	.056	.033	5.241	0	.002	0
N54	.056	.03	5.537	0	.002	.005
N55	.173	0	5.26	0	.002	0
N56	.174	0	5.241	0	.002	0
N57	.175	0	5.221	0	.002	0
N58	.174	-.004	5.549	0	0.000	0
N59	.292	-.039	5.61	0	.002	0
N60	.292	-.041	5.79	0	.002	0
N61	.292	-.039	5.656	0	.002	0
N62	.292	-.038	5.523	0	.002	0
N63	.292	-.037	5.389	0	.002	0
N64	.292	-.035	5.282	0	.002	0
N65	.197	-.008	5.241	0	.002	0
N66	.225	-.016	5.241	0	.002	0
N67	.108	.018	5.241	0	.002	0
N68	-1.635	-.437	.71	0	.022	.003
N69	-1.709	-1.487	-3.136	.024	.003	-.004
N70	-1.711	-.434	.71	0	.001	.003
N71	-.566	-.644	-3.135	.039	-.094	-.004
N72	-.6	-.393	.709	.002	-.096	.003
N73	-.558	.024	5.842	0	-.095	0

Mode Shape 8

Joint Label	X Translation	Y Translation	Z Translation	X Rotation	Y Rotation	Z Rotation
N1	.002	.048	.017	0	0	0
N2	.002	.107	0	0	0	0
N3	-.005	.018	.017	0	0	0
N4	-.005	.076	0	0	0	0
N5	0.000	0.000	0.000	.001	0	0
N6	0.000	0.000	0.000	0	0	0
N7	0.000	0.000	0.000	.001	0	0
N8	0.000	0.000	0.000	0	0	0
N9	.002	-.947	-.005	-.004	0	-.017
N10	-.005	.056	-.005	.013	0	-.003
N11	.002	-1.47	.008	-.007	0	0
N12	-.005	-.254	.008	.026	0	-.004
N13	.002	-.653	.013	.037	0	.035
N14	-.005	-.195	.013	-.023	0	.011
N15	.002	.43	.009	-.025	0	.055
N16	-.005	.191	.009	.017	0	.022
N17	.002	3.86	.002	.02	0	.049
N18	-.005	1.722	.002	-.045	0	.022
N19	.002	4.883	-.004	.544	0	-.027
N20	-.005	2.198	-.005	-.469	0	-.012
N21	.01	.108	0	0	0	0
N22	.011	.375	-.005	.069	0	-.015
N23	.011	-1.597	.008	-.005	0	0
N24	.01	.023	.013	.034	0	.031
N25	.01	-.033	.009	-.023	0	.05
N26	.01	4.214	.002	.015	0	.045
N27	.01	14.734	-.004	.471	0	-.025
N28	.011	.1	0	0	0	0
N29	.016	1.853	-.005	.049	0	-.012
N30	.016	-1.651	.008	.002	0	0
N31	.017	.692	.013	.017	0	.027
N32	.017	-.485	.009	-.011	0	.044



Company : Morrison Hershfield
 Designer : ML
 Job Number : GED-577R5 / 2000204
 Model Name : 75153-A /GOOD SAMARITAN

Dec 5, 2019
 3:00 PM
 Checked By: SWS

Mode Shape 8, (continued)

Joint Label	X Translation	Y Translation	Z Translation	X Rotation	Y Rotation	Z Rotation
N33	.013	4.362	.002	-.008	0	.039
N34	.012	24.599	-.005	.124	0	-.022
N35	.016	4.393	.002	-.003	0	.04
N36	-.026	.028	.017	0	0	0
N37	-.026	2.478	-.005	-.034	0	-.007
N38	-.011	.048	0	0	0	0
N39	-.011	.107	-.017	0	0	0
N40	-.018	.018	0	0	0	0
N41	-.018	.076	-.017	0	0	0
N42	-.011	.078	-.008	0	0	0
N43	-.005	.048	.009	0	0	0
N44	-.005	.078	0	0	0	0
N45	-.005	.107	-.008	0	0	0
N46	.002	.078	.009	0	0	.05
N47	-.014	.033	0	0	0	0
N48	-.008	.033	.009	0	0	0
N49	-.011	.018	.009	0	0	0
N50	-.002	.033	.017	0	0	0
N51	-.018	.047	-.008	0	0	0
N52	-.011	.047	0	0	0	0
N53	-.011	.076	-.008	0	0	0
N54	-.005	.047	.009	0	0	.019
N55	-.014	.092	-.017	0	0	0
N56	-.008	.092	-.008	0	0	0
N57	-.002	.092	0	0	0	0
N58	-.008	.062	0	0	0.000	0
N59	-.005	.072	.002	0	0	0
N60	-.005	.055	.007	0	0	0
N61	-.005	.067	.003	0	0	0
N62	-.005	.08	0	0	0	0
N63	-.005	.093	-.004	0	0	0
N64	-.005	.103	-.007	0	0	0
N65	-.007	.095	-.008	0	0	0
N66	-.007	.098	-.008	0	0	0
N67	-.01	.083	-.008	0	0	0
N68	-.026	-1.122	.008	.019	0	-.003
N69	-.027	2.226	-.005	-.047	0	-.006
N70	-.027	-1	.008	.021	0	-.003
N71	-.011	.559	-.005	-.078	0	-.004
N72	-.01	-.413	.008	.026	0	-.004
N73	-.011	.02	.017	0	-.001	0

Mode Shape 9

Joint Label	X Translation	Y Translation	Z Translation	X Rotation	Y Rotation	Z Rotation
N1	-.689	-.005	-2.383	0	-.019	0
N2	-.689	-.008	4.085	0	-.019	0
N3	1.786	.008	-2.383	0	-.019	0
N4	1.786	.005	4.085	0	-.019	0
N5	0.000	0.000	0.000	-.184	-.019	.053
N6	0.000	0.000	0.000	.315	-.019	.053
N7	0.000	0.000	0.000	-.184	-.019	-.138
N8	0.000	0.000	0.000	.315	-.019	-.138
N9	-.704	-.01	-1.033	0	-.037	0
N10	1.854	.005	-1.03	0	-.066	0
N11	-.718	-.012	.036	0	.02	0
N12	1.929	.004	.023	0	.127	0
N13	-.706	-.009	.576	0	.01	0



Company : Morrison Hershfield
 Designer : ML
 Job Number : GED-577R5 / 2000204
 Model Name : 75153-A /GOOD SAMARITAN

Dec 5, 2019
 3:00 PM
 Checked By: SWS

Mode Shape 9, (continued)

Joint Label	X Translation	Y Translation	Z Translation	X Rotation	Y Rotation	Z Rotation
N14	1.823	.006	.452	0	-.041	0
N15	-.696	-.006	.914	0	.009	0
N16	1.787	.008	.957	0	-.016	0
N17	-.723	.003	.279	0	.045	0
N18	1.794	.013	.269	0	.029	0
N19	-.726	.005	-.596	.002	.024	0
N20	1.793	.014	-.573	-.001	-.026	0
N21	-3.171	-.007	4.094	0	.123	0
N22	-3.229	-.013	-1.036	0	.137	0
N23	-3.195	-.011	.034	0	.17	0
N24	-3.173	-.001	.566	0	.146	0
N25	-3.161	-.002	.934	0	.147	0
N26	-3.132	.006	.278	0	.153	0
N27	-3.12	.034	-.596	.001	.125	0
N28	-3.016	-.003	4.094	0	-.23	0
N29	-4.26	-.015	-1.039	0	-.147	0
N30	-4.318	-.009	.032	0	-.158	0
N31	-4.436	.007	.547	0	-.014	0
N32	-4.431	.003	.948	0	-.017	0
N33	-3.339	.009	.276	0	-.16	0
N34	-3.218	.064	-.592	0	-.063	0
N35	-4.291	.009	.276	0	-.114	0
N36	11.304	.005	-2.39	0	-.23	0
N37	11.405	-.009	-1.043	0	-.092	0
N38	-.688	-.005	-2.376	0	-.019	0
N39	-.688	-.008	4.093	0	-.019	0
N40	1.786	.008	-2.376	0	-.019	0
N41	1.786	.005	4.093	0	-.019	0
N42	-.688	-.007	.859	0	-.019	0
N43	-.688	-.005	-2.379	0	-.019	0
N44	-.688	-.007	.855	0	-.019	0
N45	-.688	-.008	4.089	0	-.019	0
N46	-.689	-.007	.852	0	-.019	0
N47	.549	.002	-2.376	0	-.019	0
N48	.549	.002	-2.379	0	-.019	0
N49	1.786	.008	-2.379	0	-.019	0
N50	.551	.002	-2.383	0	-.02	0
N51	1.786	.007	.859	0	-.019	0
N52	1.786	.007	.855	0	-.019	0
N53	1.786	.005	4.089	0	-.019	0
N54	1.786	.007	.852	0	-.019	0
N55	.549	-.001	4.093	0	-.019	0
N56	.549	-.001	4.089	0	-.019	0
N57	.545	-.001	4.085	0	-.02	0
N58	.549	0	.855	0	0.000	0
N59	-.688	-.006	.208	0	-.019	0
N60	-.688	-.005	-1.678	0	-.019	0
N61	-.688	-.006	-.275	0	-.019	0
N62	-.688	-.007	1.127	0	-.019	0
N63	-.688	-.007	2.53	0	-.019	0
N64	-.688	-.008	3.66	0	-.019	0
N65	.301	-.003	4.089	0	-.019	0
N66	.013	-.004	4.089	0	-.019	0
N67	1.24	.002	4.089	0	-.019	0
N68	11.49	-.002	.027	0	-.072	0
N69	11.491	-.007	-1.042	0	.073	0
N70	11.428	0	.026	0	.102	0
N71	4.188	.003	-1.034	0	.396	0



Company : Morrison Hershfield
 Designer : ML
 Job Number : GED-577R5 / 2000204
 Model Name : 75153-A /GOOD SAMARITAN

Dec 5, 2019
 3:00 PM
 Checked By: SWS

Mode Shape 9, (continued)

Joint Label	X Translation	Y Translation	Z Translation	X Rotation	Y Rotation	Z Rotation
N72	3.77	.003	.024	0	.36	0
N73	4.308	.008	-2.386	0	.429	0

Mode Shape 10

Joint Label	X Translation	Y Translation	Z Translation	X Rotation	Y Rotation	Z Rotation
N1	.059	-.019	3.5	0	.01	0
N2	.059	-.015	.163	0	.01	0
N3	-1.217	.016	3.5	0	.01	0
N4	-1.217	.02	.163	0	.01	0
N5	0.000	0.000	0.000	.27	.01	-.005
N6	0.000	0.000	0.000	.012	.01	-.005
N7	0.000	0.000	0.000	.27	.01	.094
N8	0.000	0.000	0.000	.012	.01	.094
N9	.066	-.025	5.725	0	.322	0
N10	-1.221	.02	6.004	0	.317	0
N11	.07	-.024	-15.183	0	.091	0
N12	-1.227	.021	-15.402	0	.132	0
N13	.049	-.019	-1.342	0	-.26	0
N14	-1.22	.018	-1.37	0	-.3	0
N15	.061	-.017	1.856	0	-.005	0
N16	-1.219	.018	1.827	0	0	0
N17	.071	-.015	1.286	0	.026	0
N18	-1.226	.023	1.295	0	.034	0
N19	.07	-.014	-.849	0	.016	0
N20	-1.225	.025	-.846	0	.023	0
N21	.198	-.011	.164	0	.003	0
N22	.204	-.031	5.79	0	.008	0
N23	.216	-.017	-15.25	0	-.021	0
N24	.298	-.006	-1.374	0	.06	0
N25	.273	-.006	1.891	0	-.001	0
N26	.223	-.011	1.29	0	-.007	0
N27	.203	-.002	-.854	0	-.005	0
N28	-.333	-.002	.164	0	.021	0
N29	-.156	-.035	5.872	0	-.002	0
N30	-.169	-.007	-15.321	0	.007	0
N31	-.204	.009	-1.393	0	.04	0
N32	-.203	.008	1.903	0	.027	0
N33	-.33	-.002	1.294	0	.019	0
N34	-.331	.016	-.857	0	.022	0
N35	-.198	-.004	1.293	0	.024	0
N36	1.254	.006	3.515	0	-.037	0
N37	1.277	-.018	6.024	0	-.001	0
N38	.058	-.019	3.519	0	.01	0
N39	.058	-.015	.183	0	.01	0
N40	-1.218	.016	3.519	0	.01	0
N41	-1.218	.02	.183	0	.01	0
N42	.058	-.017	1.851	0	.01	0
N43	.059	-.019	3.51	0	.01	0
N44	.059	-.017	1.841	0	.01	0
N45	.059	-.015	.173	0	.01	0
N46	.059	-.017	1.827	0	.01	0
N47	-.58	-.002	3.519	0	.01	0
N48	-.579	-.002	3.51	0	.01	0
N49	-1.217	.016	3.51	0	.01	0
N50	-.578	-.002	3.5	0	.01	0
N51	-1.218	.018	1.851	0	.01	0
N52	-1.217	.018	1.841	0	.01	0



Company : Morrison Hershfield
 Designer : ML
 Job Number : GED-577R5 / 2000204
 Model Name : 75153-A /GOOD SAMARITAN

Dec 5, 2019
 3:00 PM
 Checked By: SWS

Mode Shape 10, (continued)

Joint Label	X Translation	Y Translation	Z Translation	X Rotation	Y Rotation	Z Rotation
N53	-1.217	.02	.173	0	.01	0
N54	-1.217	.018	1.829	0	.01	0
N55	-.58	.002	.183	0	.01	0
N56	-.579	.002	.173	0	.01	0
N57	-.579	.002	.163	0	.01	0
N58	-.579	0	1.841	0	0.000	0
N59	.059	-.018	2.175	0	.01	0
N60	.059	-.019	3.148	0	.01	0
N61	.059	-.018	2.424	0	.01	0
N62	.059	-.017	1.701	0	.01	0
N63	.059	-.016	.977	0	.01	0
N64	.059	-.016	.394	0	.01	0
N65	-.452	-.001	.173	0	.01	0
N66	-.303	-.005	.173	0	.01	0
N67	-.936	.012	.173	0	.01	0
N68	1.291	.012	-15.411	0	0	0
N69	1.219	-.012	6.033	0	.025	0
N70	1.217	.014	-15.42	0	.026	0
N71	-.551	.014	6.025	.001	.107	0
N72	-.523	.02	-15.414	0	.109	0
N73	-.55	.014	3.506	0	.11	0

Response Spectra Data

X Direction Spectra	ASCE 2010, Parametric Design Spectra
Modes Used	All 10 modes
Mode No. for Signs	
Modal Combination Method	CQC
Damping Ratio	5 Percent

Y Direction Spectra	ASCE 2010, Parametric Design Spectra
Modes Used	All 10 modes
Mode No. for Signs	
Modal Combination Method	CQC
Damping Ratio	5 Percent

Z Direction Spectra	ASCE 2010, Parametric Design Spectra
Modes Used	All 10 modes
Mode No. for Signs	
Modal Combination Method	CQC
Damping Ratio	5 Percent

Frequencies / Participation

Mode Number	Frequency (Hz)	Period (Sec)	Percent Modal Participation		
			X Spectra	Y Spectra	Z Spectra
1	7.09	.14			43.99
2	9.07	.11	.73		18.67
3	10.94	.09	95.21		.2
4	13.69	.07		14.31	
5	14.03	.07		18.55	
6	16.89	.06		10.31	.29
7	17.04	.06	.04	.07	35.25
8	20.52	.05		9.02	
9	21.13	.05	.15		.35



Company : Morrison Hershfield
 Designer : ML
 Job Number : GED-577R5 / 2000204
 Model Name : 75153-A /GOOD SAMARITAN

Dec 5, 2019
 3:00 PM
 Checked By: SWS

Frequencies / Participation, (continued)

Mode Number	Frequency (Hz)	Period (Sec)	Percent Modal Participation		
			X Spectra	Y Spectra	Z Spectra
10	25.08	.04	.08		.82
Totals :			96.22	52.26	99.58

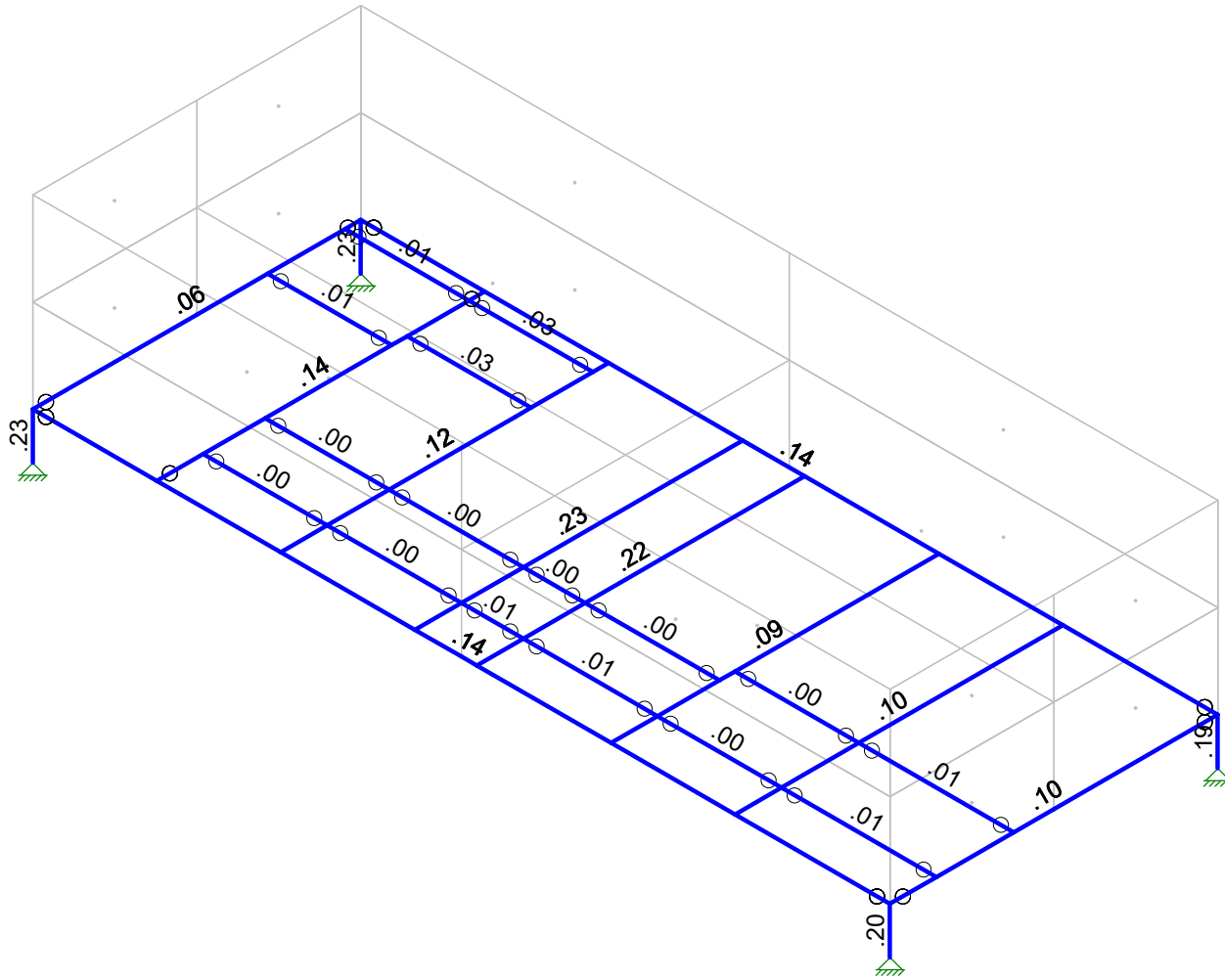
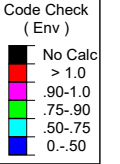
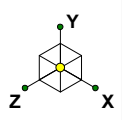

Member Code Checks Displayed (Enveloped)
Envelope Only Solution

Morrison Hershfield
ML
GED-577R5 / 2000204

75153-A /GOOD SAMARITAN

SK - 1
Dec 5, 2019 at 3:01 PM
Platform Analysis_Seismic.r3d

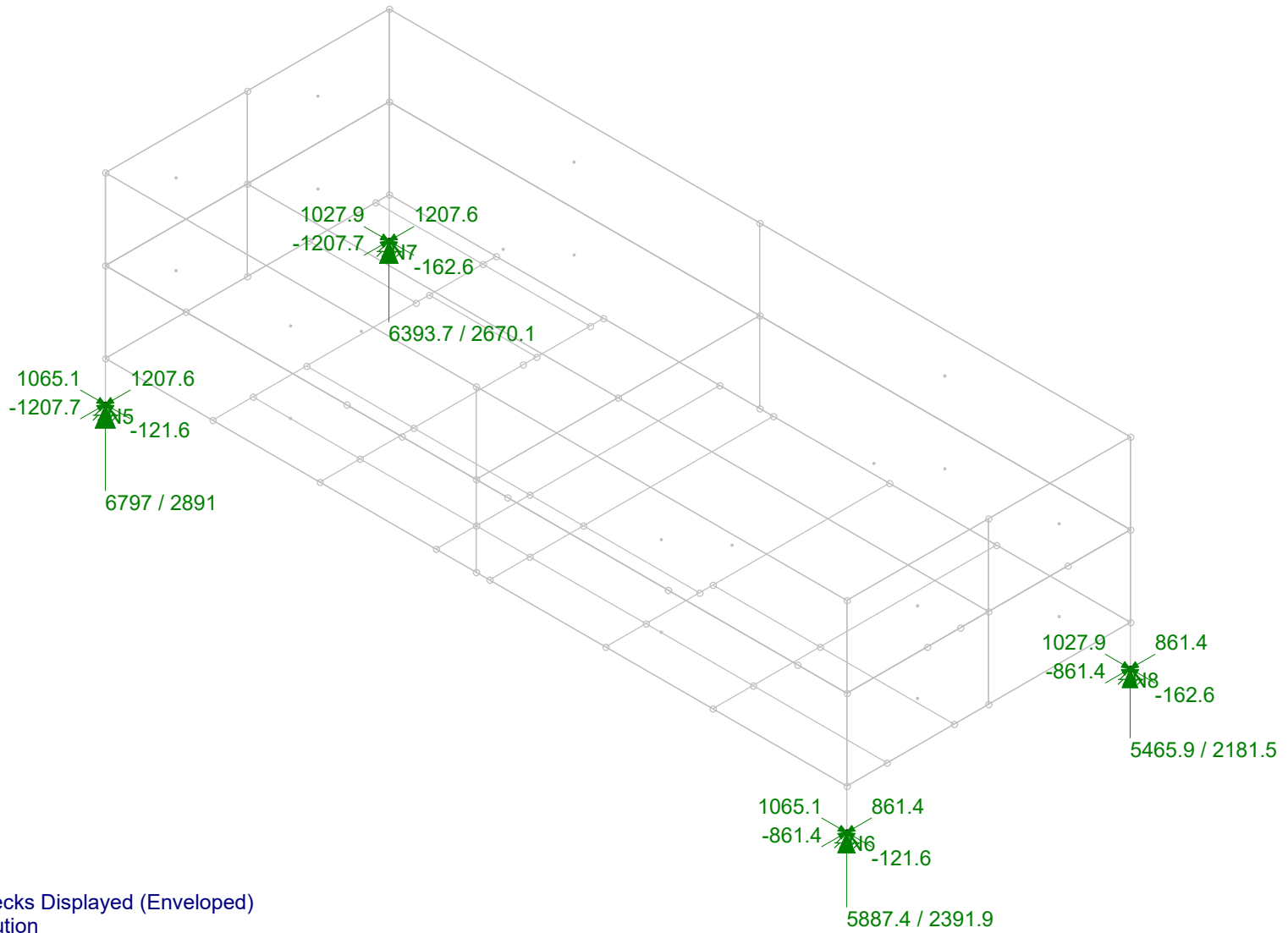
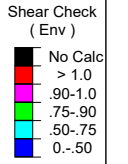
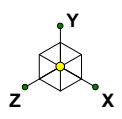

Member Shear Checks Displayed (Enveloped)
 Envelope Only Solution
 Reaction and Moment Units are lb and lb-ft (Enveloped)

Morrison Hershfield	75153-A /GOOD SAMARITAN	SK - 3
ML		Dec 5, 2019 at 3:02 PM
GED-577R5 / 2000204		Platform Analysis_Seismic.r3d

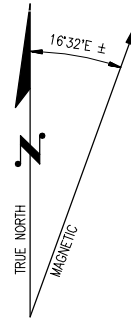
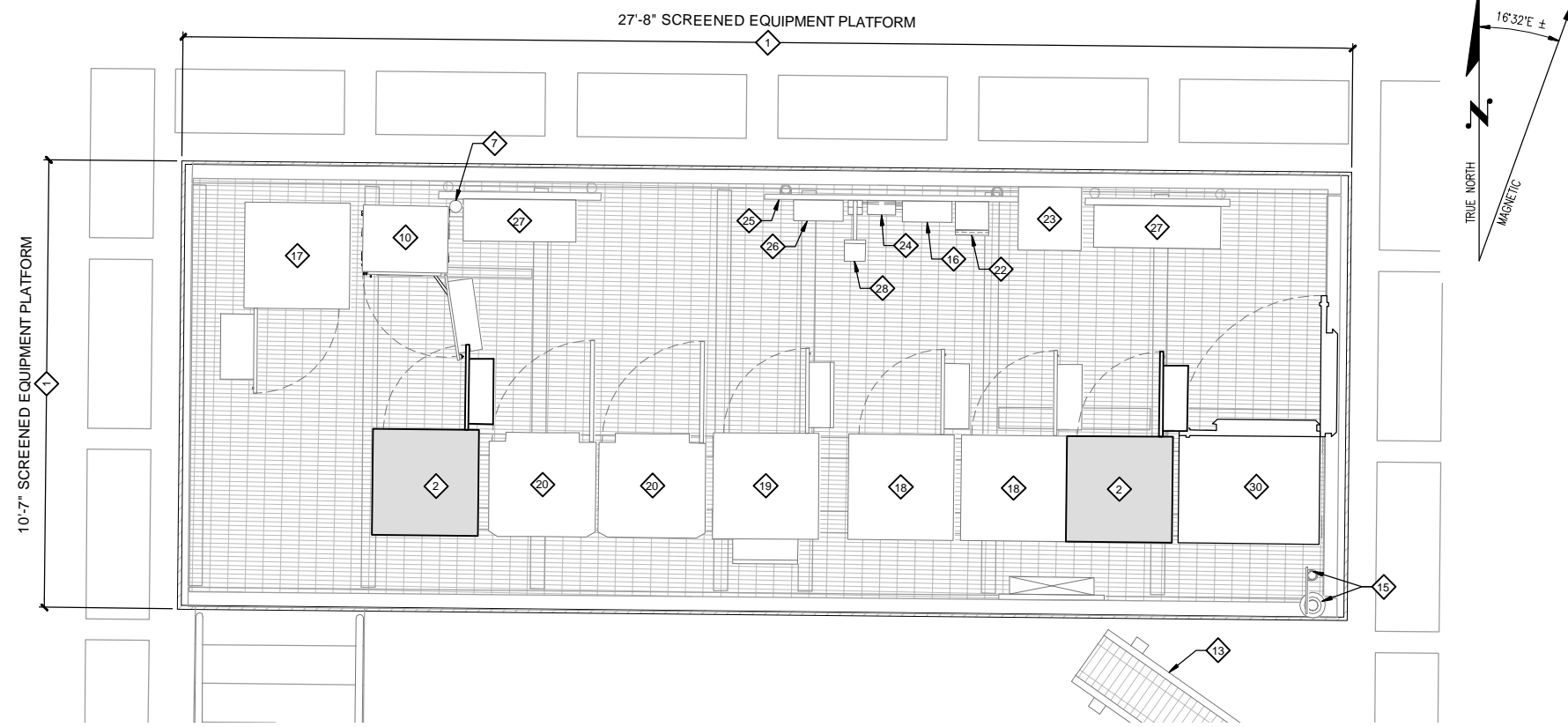

PROPOSED ENLARGED ANTENNA PLAN

22"x34" SCALE: 1/2" = 1'-0" 11"x17" SCALE: 1/4" = 1'-0"

2

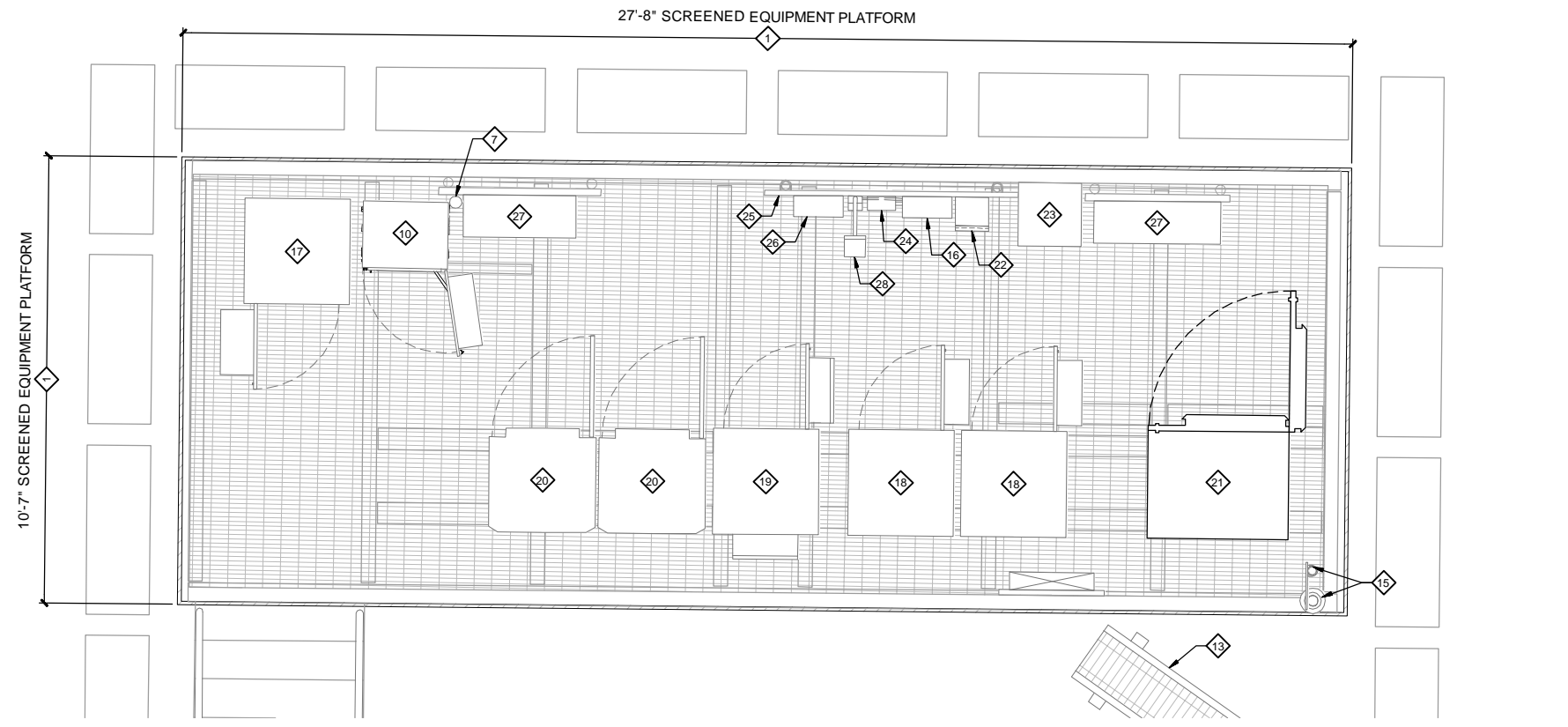

EXISTING ENLARGED EQUIPMENT PLAN

22"x34" SCALE: 1/2" = 1'-0" 11"x17" SCALE: 1/4" = 1'-0"

1

CONSTRUCTION PLAN KEYED NOTES

- 1 EXISTING AT&T SCREENED EQUIPMENT PLATFORM (27' x 10').
- 2 PROPOSED AT&T BBU CABINETS W/ (38) BATTERIES TO BE INSTALLED. (1/4)
- 7 EXISTING AT&T LTE GPS ANTENNA (TO REMAIN).
- 10 EXISTING AT&T LTE PURCELL CABINET (TO REMAIN).
- 13 EXISTING AT&T CABLE TRAY (TO REMAIN).
- 15 EXISTING AT&T GPS ANTENNAS (TO REMAIN).
- 16 EXISTING AT&T AC PANEL (TO REMAIN).
- 17 EXISTING AT&T ARGUS TE43 CABINET (TO REMAIN).
- 18 EXISTING AT&T BBU CABINET (TO REMAIN).
- 19 EXISTING AT&T ARGUS POWER CABINET (TO INSTALL (4) CORDEX RECTIFIERS) (TO REMAIN).
- 20 EXISTING AT&T GSM CABINET (TO REMAIN).
- 21 EXISTING AT&T UMTS CABINET (TO BE RELOCATED).
- 22 EXISTING AT&T GEN PLUG ENCLOSURE (TO REMAIN).
- 23 EXISTING AT&T TRANSFORMER (TO REMAIN).
- 24 EXISTING AT&T SURGE SUPPRESSION BOX (TO REMAIN).
- 25 EXISTING AT&T UTILITY H-FRAME (TO REMAIN).
- 26 EXISTING AT&T TELCO DEMARC (TO REMAIN).
- 27 EXISTING AT&T HOFFMAN BOX (TO REMAIN).
- 28 EXISTING AT&T WATERPROOF SERVICE LIGHT (TO REMAIN)
- 30 RELOCATED AT&T UMTS CABINET.

SITE NOTES

1. CONTRACTOR TO FIELD VERIFY SITE CONDITIONS DEPICTED IN THESE DRAWING AND NOTIFY THE ENGINEER OF RECORDED OF ANY DISCREPANCIES RELATED TO THE PROPOSED SCOPE OF WORK.
2. EXISTING UNDERGROUND UTILITY LOCATIONS ARE APPROXIMATE. CONTRACTOR SHALL CALL FOR LOCATES PRIOR TO DIGGING.

Plan 2012 equipment configuration showing many cabinets.



LDC Commercial Infrastructure Residential Telecom
THE CIVIL ENGINEERING GROUP
 14201 NE 200th St., #100 Ph. 425.806.1889
 Woodinville, WA 98072 Fx. 425.462.2893
 www.LDCcorp.com

DATE:	10-19-12
DRAWN BY:	CAG
CHECKED BY:	MEV

REVISIONS			
REV	DATE	DESCRIPTION	BY
1	10-19-12	PRELIMINARY CONSTRUCTION	MEV
2	11-02-12	FINAL CONSTRUCTION	MEV



SITE
 WA659
 GOOD SAMARITAN
 407 14TH AVE SE
 PUYALLUP, WA 98372

SHEET TITLE
 ENLARGED SITE PLAN

SHEET NUMBER
A-2

Drawing: P:\2012\Telecom\12-298 AT&T - WA659 Good Samaritan\Drawings\Construction\12-298 CD-A2-0.dwg Plotted: Nov 02, 2012 - 3:05pm

Section 1 - RFDS GENERAL INFORMATION

RFDS NAME:	WATAU3055	DATE:	03/29/2021	RF DESIGN ENG:	Gisele Lima	RF PERF ENG:	Aldin Hajiric	RFDS PROGRAM TYPE:	2022 5G NR Radio		
ISSUE:		Approved? (Y/N):	Yes	RF DESIGN PHONE:	4259193253	RF PERF PHONE:	4257538163	RFDS TECHNOLOGY:	5G NR 1SR CBAND		
REVISION:	2	RF MANAGER:	Piero Rovani	RF DESIGN EMAIL:	gl013y@us.att.com	RF PERF EMAIL:	ah263n@us.att.com	STATE/STATUS:	Final/Approved		
INITIATIVE /PROJECT:	v3: 1 Rescoped on (12/14/2022): Putting C-band & Dod on the existing lease area 3' on top of LTE at 90' tip height. C-band and Dod will be side by side on Pos 5 & Pos 6. v3: (02/11/2022) C&E request to have 2 KMW-L2 antennas per sector due to space issue. EPBQ-652L8H8 will be remove and UMTS will be shutdown early. Updated Sec 15 v2: (12/15/2021) Updated BBU, CellID, RF Configuration/Equipment. v1: (03/29/2021) Initial RFDS Remove UMTS, We need 3' separation from C-Band and other Antennas.					ADDITIONAL WORKFLOW NOTIFICATIONS:		RFDS ID:	4441431		
						RFDS VERSION:	1.00	Created By:	jx615k	Updated By:	mc482r
						UMTS FREQUENCY:		Date Created:	3/29/2021 4:18:09 PM	Date Updated:	12/16/2022 7:57:19 PM
						LTE FREQUENCY:		Estimated SQIN:	21.518	Expiration :	
						5G FREQUENCY:	CBAND, DoD	RER Initiative:		Calculation ID:	2022121619513024 51
						I-PLAN JOB # 1:	WR_ _RWOR-21-04503	IPLAN PRD GRP SUB GRP #1:	5G NR Software Radio 5G NR Activation		
						I-PLAN JOB # 2:	WR_ _RWOR-21-04504	IPLAN PRD GRP SUB GRP #2:	5G NR Software Radio 5G NR Activation		
						I-PLAN JOB # 3:	WR_ _RWOR-21-04505	IPLAN PRD GRP SUB GRP #3:	5G NR Radio 5G NR 1SR CBand		
						I-PLAN JOB # 4:	WR_ _RWOR-21-04165	IPLAN PRD GRP SUB GRP #4:	5G NR Radio 5G NR 1SR CBand		
						I-PLAN JOB # 5:		IPLAN PRD GRP SUB GRP #5:			
						I-PLAN JOB # 6:		IPLAN PRD GRP SUB GRP #6:			
						I-PLAN JOB # 7:		IPLAN PRD GRP SUB GRP #7:			
						I-PLAN JOB # 8:		IPLAN PRD GRP SUB GRP #8:			
						I-PLAN JOB # 9:		IPLAN PRD GRP SUB GRP #8:			
						I-PLAN JOB # 10:		IPLAN PRD GRP SUB GRP #8:			
						I-PLAN JOB # 11:		IPLAN PRD GRP SUB GRP #8:			
						I-PLAN JOB # 12:		IPLAN PRD GRP SUB GRP #8:			
						I-PLAN JOB # 13:		IPLAN PRD GRP SUB GRP #8:			
						I-PLAN JOB # 14:		IPLAN PRD GRP SUB GRP #8:			
						I-PLAN JOB # 15:		IPLAN PRD GRP SUB GRP #8:			
						I-PLAN JOB # 16:		IPLAN PRD GRP SUB GRP #8:			

Section 2 - LOCATION INFORMATION

USID:	75153	FA LOCATION CODE:	10029581	LOCATION NAME:	GOOD SAMARITAN	ORACLE PTN # 1:		PACE JOB # 1:	MRWOR058813		
REGION:	WEST	MARKET CLUSTER:	SEATTLE/OREGON/NO. ID	MARKET:	WASHINGTON	ORACLE PTN # 2:		PACE JOB # 2:	MRWOR058864		
ADDRESS:	407 14TH AVENUE SOUTHEAST	CITY:	PUYALLUP	STATE:	WA	ORACLE PTN # 3:	3801A10ZF0	PACE JOB # 3:	MRWOR059479		
ZIP CODE:	98371	COUNTY:	PIERCE	LONG (DEC. DEG.):	-122.2905583	ORACLE PTN # 4:	3801A10ZVD	PACE JOB # 4:	MRWOR059318		
LATITUDE (D-M-S):	47d 10m46.2s	LONGITUDE (D-M-S):	-122d -17m-26.00988s	LAT (DEC. DEG.):	47.1795000	ORACLE PTN # 5:		PACE JOB # 5:			
DIRECTIONS, ACCESS AND EQUIPMENT LOCATION:	FROM SEATTLE, GO SOUTH ON I-5.TAKE EXIT 154A (ON THE LEFT SIDE OF THE FREEWAY) AND MERGE ONTO I-405 HEADING WEST TOWARDS RENTON.TAKE EXIT 2 AND MERGE ONTO HWY 167 GOING SOUTH TOWARD PUYALLUP.TAKE HWY 167 TO THE HWY 512/161 EXIT JUST PASS THE HWY 410 EXIT.EXIT HWY 167 ONTO HWY 512.FROM HWY 512 TAKE THE EXIT FOR S MERIDIAN.TURN LEFT AT THE END OF THE OFF RAMP AND FOLLOW S MERIDIAN SOUTH TO THE SE-15TH AVE-SW INTERSECTION.TURN LEFT ONTO SE 15TH AVE. FOLLOW THIS UP THE HILL TO THE 3RD ST SE ROUNDABOUT AND GO LEFT (NORTH) ON 3RD ST SE.FOLLOW THIS DOWN THE HILL AND THE ROAD WILL TURN RIGHT (EAST) BECOMING 13TH AVE SE.LEVEL C - MEADOW PICK UP WILL BE TO THE RIGHT AFTER THE PARKING GARAGE.FIND A PLACE TO PARK ON THE STREET AND GO TO THE LEVEL C - MEADOW PICK UP LOBBY.CONTACT STEVE PRIDEAUX (THE FACILITIES MANAGER) FOR AN ESCORT TO THE SITE AT (CELL) 253-732-5849.BE SURE TO HAVE AN AT&T BADGE VISIBLE.THE EQUIPMENT IS ON ROOF TOP OF THE NORTHWEST BUILDING WITH THE FLAG POLE NEXT TO THE PARKING GARAGETHE SITE COMPOUND IS TO THE LEFT AS YOU EXIT THE ROOF DOOR AND DOES NOT HAVE A LOCK.WHEN EXITING THE ELEVATORS AT THE PENTHOUSE, THE POWER METER IS ON THE FAR WALL STRAIGHT AHEAD.THIS SITE HAS 24/7 ACCESS.AT&T TECHNICIANS.BUSINESS HOURS ACCESS: CONTACT STEVE PRIDEAUX AND REQUEST ACCESS/ESCORT TO EQUIPMENT ON ROOF (CELL) 253-732-5849.IF POSSIBLE, LET HIM KNOW IN ADVANCE.ALSO, IF THERE IS NO RESPONSE FROM STEVE PRIDEAUX, CONTACT SECURITY FOR ACCESS.AFTER HOURS ACCESS: CALL MAINT FIRST AT 253 697-1802, IF THAT FAILS THEN CALL CALL SECURITY AT 253 697-1735.VENDORS:CONTACT STEVE PRIDEAUX (THE FACILITIES MANAGER) FOR ANY WORK BEING DONE. (CELL) 253-732-5849MAKE CONTACT WITH HIM A FEW DAYS BEFORE GOING THERE AND BRIEF HIM ON THE SCOPE.TELCO: GSM T1S ARE GSMOE.POWER METER SERIAL NUMBER:2647-481674 POWER PROVIDER: GOOD SAMARITAN HOSPITALGEN PLUG: N/A - ROOFTOP SITEGEN CORD LENGTH: N/A - ROOFTOP SITEVALIDATED BY CL8296 9/14/2016					ORACLE PTN # 6:		PACE JOB # 6:			
						ORACLE PTN # 7:		PACE JOB # 7:			
						ORACLE PTN # 8:		PACE JOB # 8:			
						ORACLE PTN # 9:		PACE JOB # 9:			
						ORACLE PTN # 10:		PACE JOB # 10:			
						ORACLE PTN # 11:		PACE JOB # 11:			
						ORACLE PTN # 12:		PACE JOB # 12:			
						ORACLE PTN # 13:		PACE JOB # 13:			
						ORACLE PTN # 14:		PACE JOB # 14:			
						ORACLE PTN # 15:		PACE JOB # 15:			
						ORACLE PTN # 16:		PACE JOB # 16:			
						BORDER CELL WITH CONTOUR COORD:		SEARCH RING NAME:			
						AM STUDY REQ'D (Y/N):	No	SEARCH_RING_ID:			
						FREQ COORD:		BTA:		MSA / RSA:	
						RF DISTRICT:	17	LAC(UMTS):	42970		
						RF ZONE:	A	RNC(UMTS):	TACNWADNCRAR22		
						PARENT NAME(UMTS):	TACOMA - ALLU RNC 9370-22	MME POOL ID(LTE):	FF49		

Section 3 - LICENSE COVERAGE/FILING INFORMATION

CGSA - NO FILING TRIGGERED (Yes/No):	No	CGSA LOSS:		PCS REDUCED - UPS ZIP:		CGSA CALL SIGNS:	
CGSA - MINOR FILING NEEDED (Yes/No):	No	CGSA EXT AGMT NEEDED:		PCS POPS REDUCED:			
CGSA - MAJOR FILING NEEDED (Yes/No):	Yes	CGSA SCORECARD UPDATED:					

Section 4 - TOWER/REGULATORY INFORMATION

ANTENNA POSITION is LEFT to RIGHT from BACK OF ANTENNA (unless otherwise specified)	ANTENNA POSITION 1	ANTENNA POSITION 2	ANTENNA POSITION 3	ANTENNA POSITION 4	ANTENNA POSITION 5	ANTENNA POSITION 6	ANTENNA POSITION 7
ANTENNA MAKE - MODEL	EPBQ-654L8H8-L2			EPBQ-654L8H8-L2			
ANTENNA VENDOR	KMW			KMW			
ANTENNA SIZE (H x W x D)	96X21X6.3			96X21X6.3			
ANTENNA WEIGHT	86			86			
AZIMUTH	40			40			
MAGNETIC DECLINATION							
RADIATION CENTER (feet)	79			79			
ANTENNA TIP HEIGHT	83			83			
MECHANICAL DOWNTILT	0			0			
FEEDER AMOUNT	0			0			
VERTICAL SEPARATION from ANTENNA ABOVE (TIP to TIP)							
VERTICAL SEPARATION from ANTENNA BELOW (TIP to TIP)							
HORIZONTAL SEPARATION from CLOSEST ANTENNA to LEFT (CENTERLINE to CENTERLINE)							
HORIZONTAL SEPARATION from CLOSEST ANTENNA to RIGHT (CENTERLINE to CENTERLINE)							
HORIZONTAL SEPARATION from ANOTHER ANTENNA (which antenna # / # of inches)							
Antenna RET Motor (QTY/MODEL)							
SURGE ARRESTOR (QTY/MODEL)							
DIPLEXER (QTY/MODEL)							
DUPLEXER (QTY/MODEL)							
Antenna RET CONTROL UNIT (QTY/MODEL)							
DC BLOCK (QTY/MODEL)							
TMA/LNA (QTY/MODEL)							
CURRENT INJECTORS FOR TMA (QTY/MODEL)							
PDU FOR TMA (QTY/MODEL)							
FILTER (QTY/MODEL)							
SQUID (QTY/MODEL)	3	DC2-48-60-0-9E		3	FC12-PC6-10E		
FIBER TRUNK (QTY/MODEL)							
DC TRUNK (QTY/MODEL)							
REPEATER (QTY/MODEL)							
RRH - 700 band (QTY/MODEL)				1	AirScale Dual RRH 4T4R B12/14 320W AHLBA		
RRH - 850 band (QTY/MODEL)	1	AirScale RRH 4T4R B5 160W AHCA					
RRH - 1900 band (QTY/MODEL)				1	AirScale Dual RRH 4T4R B25/66 320W AHFIB		
RRH - AWS band (QTY/MODEL)				1	RRH is shared with another band		
RRH - WCS band (QTY/MODEL)	1	RRH4x25-WCS-4R					
Additional RRH #1 - any band (QTY/MODEL)							
Additional RRH #2 - any band (QTY/MODEL)							
RRH 7B 1 (QTY/MODEL)							
RRH 7B 2 (QTY/MODEL)							
RRH 7B 3 (QTY/MODEL)							
Additional Component 1 (QTY/MODEL)							
Additional Component 2 (QTY/MODEL)							
Additional Component 3 (QTY/MODEL)							
Local Market Note 1	ELECTRICAL TILTS: N005(02) , WCS(02) , L7(02) , L7_PS(02) , L9(02) , L2(02) , L2_1(02) ERP: N005(463) , WCS(3672) , L7(3228) , L7_PS(3228) , L9(4897) , L2(2741) , L2_1(2741)						
Local Market Note 2	ANTENNA PORTS: N005(7c+7d+7g+7h) , WCS(7i+7j+7k+7l) , L7(10c+10d+10g+10h) , L7_PS(10c+10d+10g+10h) , L9(10a+10b+10e+10f) , L2(10a+10b+10e+10f) , L2_1(10a+10b+10e+10f)						
Local Market Note 3	SECTOR NAME: N005(WAWN003055_N005A_1) , WCS(WAL03055_3A_1) , L7(WAL03055_7A_1) , L7_PS(WAL03055_7A_2_F) , L9(WAL03055_9A_1) , L2(WAL03055_2A_1) , L2_1(WAL03055_2A_2)						

PORT SPECIFIC FIELDS	PORT NUMBER	USEID (CSSng)	USEID (Atoll)	ATOLL TXID	ATOLL CELL ID	TX/RX ?	TECHNOLOGY/FREQUENCY	ANTENNA ATOLL	ANTENNA GAIN	ELECTRICAL AZIMUTH	ELECTRICAL TILT	RRH LOCATION (Top/Bottom/Integrated/None)	FEEDERS TYPE	FEEDER LENGTH (feet)	RXAIT KIT MODULE?	TRIPLEXER or LLC (QTY)	TRIPLEXER or LLC (MODEL)	SCPA/MCPA MODULE?	HATCHPLATE POWER (Watts)	ERP (Watts)	Antenna RET Name	CABLE NUMBER	CABLE ID (CSSNG)
ANTENNA POSITION 1	PORT 1			WAWN003055_N005_A_1	WAWN003055_N005		5G 850	EPBQ-654L8H8-L2_851MHZ_02DT	16		2	Top	FIBER	100						463			
	PORT 2			WAWN003055_N005	WAWN003055_N005		5G 850	EPBQ-654L8H8-	16		2	Top	FIBER	100							463		

PRCTI20230490

			A_1	A_1			L2_851MHz_02DT												
ANTENNA POSITION 4	PORT 3		WAWN003055_N005 A_1	WAWN003055_N005 A_1	5G 850		EPBQ-654L8H8- L2_851MHz_02DT	16		2	Top	FIBER	100						463
	PORT 4		WAWN003055_N005 A_1	WAWN003055_N005 A_1	5G 850		EPBQ-654L8H8- L2_851MHz_02DT	16		2	Top	FIBER	100						463
	PORT 9		WAL03055_3A_1	WAL03055_3A_1	LTE WCS		EPBQ-654L8H8- L2_2355MHz_02DT	18		2	Top	FIBER	106						3672
	PORT 10		WAL03055_3A_1	WAL03055_3A_1	LTE WCS		EPBQ-654L8H8- L2_2355MHz_02DT	18		2	Top	FIBER	106						3672
	PORT 11		WAL03055_3A_1	WAL03055_3A_1	LTE WCS		EPBQ-654L8H8- L2_2355MHz_02DT	18		2	Top	FIBER	106						3672
	PORT 12		WAL03055_3A_1	WAL03055_3A_1	LTE WCS		EPBQ-654L8H8- L2_2355MHz_02DT	18		2	Top	FIBER	106						3672
ANTENNA POSITION 4	PORT 1		WAL03055_7A_1, WAL03055_7A_2_F	WAL03055_7A_1, WAL03055_7A_2_F	LTE 700		EPBQ-654L8H8- L2_722MHz_02DT	15		2	Top	FIBER	106						6456
	PORT 2		WAL03055_7A_1, WAL03055_7A_2_F	WAL03055_7A_1, WAL03055_7A_2_F	LTE 700		EPBQ-654L8H8- L2_722MHz_02DT	15		2	Top	FIBER	106						6456
	PORT 3		WAL03055_7A_1, WAL03055_7A_2_F	WAL03055_7A_1, WAL03055_7A_2_F	LTE 700		EPBQ-654L8H8- L2_722MHz_02DT	15		2	Top	FIBER	106						6456
	PORT 4		WAL03055_7A_1, WAL03055_7A_2_F	WAL03055_7A_1, WAL03055_7A_2_F	LTE 700		EPBQ-654L8H8- L2_722MHz_02DT	15		2	Top	FIBER	106						6456
	PORT 5		WAL03055_9A_1, WAL03055_2A_1	WAL03055_9A_1, WAL03055_2A_1, WAL03055_2A_2	LTE 1900,LTE AWS		EPBQ-654L8H8- L2_2130MHz_02DT	18		2	Top	FIBER	106						9999
	PORT 6		WAL03055_9A_1, WAL03055_2A_1	WAL03055_9A_1, WAL03055_2A_1, WAL03055_2A_2	LTE 1900,LTE AWS		EPBQ-654L8H8- L2_2130MHz_02DT	18		2	Top	FIBER	106						9999
	PORT 7		WAL03055_9A_1, WAL03055_2A_1	WAL03055_9A_1, WAL03055_2A_1, WAL03055_2A_2	LTE 1900,LTE AWS		EPBQ-654L8H8- L2_2130MHz_02DT	18		2	Top	FIBER	106						9999
	PORT 8		WAL03055_9A_1, WAL03055_2A_1	WAL03055_9A_1, WAL03055_2A_1, WAL03055_2A_2	LTE 1900,LTE AWS		EPBQ-654L8H8- L2_2130MHz_02DT	18		2	Top	FIBER	106						9999

ANTENNA POSITION is LEFT to RIGHT from BACK OF ANTENNA (unless otherwise specified)	ANTENNA POSITION 1	ANTENNA POSITION 2	ANTENNA POSITION 3	ANTENNA POSITION 4	ANTENNA POSITION 5	ANTENNA POSITION 6	ANTENNA POSITION 7
ANTENNA MAKE - MODEL	EPBQ-654L8H8-L2			EPBQ-654L8H8-L2			
ANTENNA VENDOR	KMW			KMW			
ANTENNA SIZE (H x W x D)	96X21X6.3			96X21X6.3			
ANTENNA WEIGHT	86			86			
AZIMUTH	215			215			
MAGNETIC DECLINATION							
RADIATION CENTER (feet)	80			80			
ANTENNA TIP HEIGHT	84			84			
MECHANICAL DOWNTILT	2			2			
FEEDER AMOUNT	0			0			
VERTICAL SEPARATION from ANTENNA ABOVE (TIP to TIP)							
VERTICAL SEPARATION from ANTENNA BELOW (TIP to TIP)							
HORIZONTAL SEPARATION from CLOSEST ANTENNA to LEFT (CENTERLINE to CENTERLINE)							
HORIZONTAL SEPARATION from CLOSEST ANTENNA to RIGHT (CENTERLINE to CENTERLINE)							
HORIZONTAL SEPARATION from ANOTHER ANTENNA (which antenna # / # of inches)							
Antenna RET Motor (QTY/MODEL)							
SURGE ARRESTOR (QTY/MODEL)							
DIPLEXER (QTY/MODEL)							
DUPLEXER (QTY/MODEL)							
Antenna RET CONTROL UNIT (QTY/MODEL)							
DC BLOCK (QTY/MODEL)							
TMA/LNA (QTY/MODEL)							
CURRENT INJECTORS FOR TMA (QTY/MODEL)							
PDU FOR TMA (QTY/MODEL)							
FILTER (QTY/MODEL)							
SQUID (QTY/MODEL)	3	DC2-48-60-0-9E					
FIBER TRUNK (QTY/MODEL)							
DC TRUNK (QTY/MODEL)							
REPEATER (QTY/MODEL)							
RRH - 700 band (QTY/MODEL)				1	AirScale Dual RRH 4T4R B12/14 320W AHLBA		
RRH - 850 band (QTY/MODEL)	1	AirScale RRH 4T4R B5 160W AHCA					
RRH - 1900 band (QTY/MODEL)				1	AirScale Dual RRH 4T4R B25/66 320W AHFIB		
RRH - AWS band (QTY/MODEL)				1	RRH is shared with another band		
RRH - WCS band (QTY/MODEL)	1	RRH4x25-WCS-4R					
Additional RRH #1 - any band (QTY/MODEL)							
Additional RRH #2 - any band (QTY/MODEL)							
RRH 7B 1 (QTY/MODEL)							
RRH 7B 2 (QTY/MODEL)							
RRH 7B 3 (QTY/MODEL)							
Additional Component 1 (QTY/MODEL)							
Additional Component 2 (QTY/MODEL)							
Additional Component 3 (QTY/MODEL)							
Local Market Note 1	ELECTRICAL TILTS: N005(02) , WCS(02) , L7(04) , L7_PS(04) , L9(02) , L2(02) , L2_1(02) ERP: N005(463) , WCS(3672) , L7(3303) , L7_PS(3303) , L9(4897) , L2(2741) , L2_1(2741)						
Local Market Note 2	ANTENNA PORTS: N005(13c+13d+13g+13h) , WCS(13h+13j+13k+13l) , L7(16c+16d+16g+16h) , L7_PS(16c+16d+16g+16h) , L9(16a+16b+16e+16f) , L2(16a+16b+16e+16f) , L2_1(16a+16b+16e+16f)						
Local Market Note 3	SECTOR NAME: N005(WAWN003055_N005B_1) , WCS(WAL03055_3B_1) , L7(WAL03055_7B_1) , L7_PS(WAL03055_7B_2_F) , L9(WAL03055_9B_1) , L2(WAL03055_2B_1) , L2_1(WAL03055_2B_2)						

PORT SPECIFIC FIELDS	PORT NUMBER	USEID (CSSng)	USEID (Atoll)	ATOLL TXID	ATOLL CELL ID	TX/RX ?	TECHNOLOGY/FREQUENCY	ANTENNA ATOLL	ANTENNA GAIN	ELECTRICAL AZIMUTH	ELECTRICAL TILT	RRH LOCATION (Top/Bottom/Integrated/None)	FEEDERS TYPE	FEEDER LENGTH (feet)	RXAIT KIT MODULE?	TRIPLEXER or LLC (QTY)	TRIPLEXER or LLC (MODEL)	SCPA/MCPA MODULE?	HATCHPLATE POWER (Watts)	ERP (Watts)	Antenna RET Name	CABLE NUMBER	CABLE ID (CSSNG)
ANTENNA POSITION 1	PORT 1			WAWN003055_N005B_1	WAWN003055_N005		5G 850	EPBQ-654L8H8-L2_851MHZ_02DT	16		2	Top	FIBER	100						463			
	PORT 2			WAWN003055_N005	WAWN003055_N005		5G 850	EPBQ-654L8H8-	16		2	Top	FIBER	100							463		

ANTENNA POSITION is LEFT to RIGHT from BACK OF ANTENNA (unless otherwise specified)	ANTENNA POSITION 1	ANTENNA POSITION 2	ANTENNA POSITION 3	ANTENNA POSITION 4	ANTENNA POSITION 5	ANTENNA POSITION 6	ANTENNA POSITION 7
ANTENNA MAKE - MODEL	EPBQ-654L8H8-L2			EPBQ-654L8H8-L2			
ANTENNA VENDOR	KMW			KMW			
ANTENNA SIZE (H x W x D)	96X21X6.3			96X21X6.3			
ANTENNA WEIGHT	86			86			
AZIMUTH	315			315			
MAGNETIC DECLINATION							
RADIATION CENTER (feet)	79			79			
ANTENNA TIP HEIGHT	83			83			
MECHANICAL DOWNTILT	2			2			
FEEDER AMOUNT	0			0			
VERTICAL SEPARATION from ANTENNA ABOVE (TIP to TIP)							
VERTICAL SEPARATION from ANTENNA BELOW (TIP to TIP)							
HORIZONTAL SEPARATION from CLOSEST ANTENNA to LEFT (CENTERLINE to CENTERLINE)							
HORIZONTAL SEPARATION from CLOSEST ANTENNA to RIGHT (CENTERLINE to CENTERLINE)							
HORIZONTAL SEPARATION from ANOTHER ANTENNA (which antenna # / # of inches)							
Antenna RET Motor (QTY/MODEL)							
SURGE ARRESTOR (QTY/MODEL)							
DIPLEXER (QTY/MODEL)							
DUPLEXER (QTY/MODEL)							
Antenna RET CONTROL UNIT (QTY/MODEL)							
DC BLOCK (QTY/MODEL)							
TMA/LNA (QTY/MODEL)							
CURRENT INJECTORS FOR TMA (QTY/MODEL)							
PDU FOR TMA (QTY/MODEL)							
FILTER (QTY/MODEL)							
SQUID (QTY/MODEL)	3	DC2-48-60-0-9E					
FIBER TRUNK (QTY/MODEL)							
DC TRUNK (QTY/MODEL)							
REPEATER (QTY/MODEL)							
RRH - 700 band (QTY/MODEL)				1	AirScale Dual RRH 4T4R B12/14 320W AHLBA		
RRH - 850 band (QTY/MODEL)	1	AirScale RRH 4T4R B5 160W AHCA					
RRH - 1900 band (QTY/MODEL)				1	AirScale Dual RRH 4T4R B25/66 320W AHFIB		
RRH - AWS band (QTY/MODEL)				1	RRH is shared with another band		
RRH - WCS band (QTY/MODEL)	1	RRH4x25-WCS-4R					
Additional RRH #1 - any band (QTY/MODEL)							
Additional RRH #2 - any band (QTY/MODEL)							
RRH 7B 1 (QTY/MODEL)							
RRH 7B 2 (QTY/MODEL)							
RRH 7B 3 (QTY/MODEL)							
Additional Component 1 (QTY/MODEL)							
Additional Component 2 (QTY/MODEL)							
Additional Component 3 (QTY/MODEL)							
Local Market Note 1	ELECTRICAL TILTS: N005(02) , WCS(02) , L7(02) , L7_PS(02) , L9(03) , L2(03) , L2_1(03) ERP: N005(463) , WCS(3672) , L7(3228) , L7_PS(3228) , L9(5011) , L2(2741) , L2_1(2741)						
Local Market Note 2	ANTENNA PORTS: N005(1c+1d+1g+1h) , WCS(1i+1j+1k+1l) , L7(4c+4d+4g+4h) , L7_PS(4c+4d+4g+4h) , L9(4a+4b+4e+4f) , L2(4a+4b+4e+4f) , L2_1(4a+4b+4e+4f)						
Local Market Note 3	SECTOR NAME: N005(WAWN003055_N005C_1) , WCS(WAL03055_3C_1) , L7(WAL03055_7C_1) , L7_PS(WAL03055_7C_2_F) , L9(WAL03055_9C_1) , L2(WAL03055_2C_1) , L2_1(WAL03055_2C_2)						

PORT SPECIFIC FIELDS	PORT NUMBER	USEID (CSSng)	USEID (Atoll)	ATOLL TXID	ATOLL CELL ID	TX/RX ?	TECHNOLOGY/FREQUENCY	ANTENNA ATOLL	ANTENNA GAIN	ELECTRICAL AZIMUTH	ELECTRICAL TILT	RRH LOCATION (Top/Bottom/Integrated/None)	FEEDERS TYPE	FEEDER LENGTH (feet)	RXAIT KIT MODULE?	TRIPLEXER or LLC (QTY)	TRIPLEXER or LLC (MODEL)	SCPA/MCPA MODULE?	HATCHPLATE POWER (Watts)	ERP (Watts)	Antenna RET Name	CABLE NUMBER	CABLE ID (CSSNG)
ANTENNA POSITION 1	PORT 1			WAWN003055_N005_C_1	WAWN003055_N005		5G 850	EPBQ-654L8H8-L2_851MHZ_02DT	16		2	Top	FIBER	100						463			
	PORT 2			WAWN003055_N005	WAWN003055_N005		5G 850	EPBQ-654L8H8-	16		2	Top	FIBER	100							463		

ANTENNA POSITION is LEFT to RIGHT from BACK OF ANTENNA (unless otherwise specified)	ANTENNA POSITION 1	ANTENNA POSITION 2	ANTENNA POSITION 3	ANTENNA POSITION 4	ANTENNA POSITION 5	ANTENNA POSITION 6	ANTENNA POSITION 7
ANTENNA MAKE - MODEL	EPBQ-654L8H8-L2			EPBQ-654L8H8-L2	AEQK	AEQU	
ANTENNA VENDOR	KMW			KMW	Nokia	Nokia	
ANTENNA SIZE (H x W x D)	96X21X6.3			96X21X6.3	29.5X17.7X9.5	29.5X17.7X9.5	
ANTENNA WEIGHT	86			86	99.2	99.2	
AZIMUTH	40			40	40	40	
MAGNETIC DECLINATION							
RADIATION CENTER (feet)	80			80	88.75	88.75	
ANTENNA TIP HEIGHT	84			84	90	90	
MECHANICAL DOWNTILT	0			0	0	0	
FEEDER AMOUNT	0			0	0	0	
VERTICAL SEPARATION from ANTENNA ABOVE (TIP to TIP)							
VERTICAL SEPARATION from ANTENNA BELOW (TIP to TIP)							
HORIZONTAL SEPARATION from CLOSEST ANTENNA to LEFT (CENTERLINE to CENTERLINE)							
HORIZONTAL SEPARATION from CLOSEST ANTENNA to RIGHT (CENTERLINE to CENTERLINE)							
HORIZONTAL SEPARATION from ANOTHER ANTENNA (which antenna # / # of inches)							
Antenna RET Motor (QTY/MODEL)							
SURGE ARRESTOR (QTY/MODEL)							
DIPLEXER (QTY/MODEL)							
DUPLEXER (QTY/MODEL)							
Antenna RET CONTROL UNIT (QTY/MODEL)							
DC BLOCK (QTY/MODEL)							
TMA/LNA (QTY/MODEL)							
CURRENT INJECTORS FOR TMA (QTY/MODEL)							
PDU FOR TMAS (QTY/MODEL)							
FILTER (QTY/MODEL)							
SQUID (QTY/MODEL)	3	DC2-48-60-0-9E		3	FC12-PC6-10E		
FIBER TRUNK (QTY/MODEL)							
DC TRUNK (QTY/MODEL)							
REPEATER (QTY/MODEL)							
RRH - 700 band (QTY/MODEL)				1	AirScale Dual RRH 4T4R B12/14 320W AHLBA		
RRH - 850 band (QTY/MODEL)	1	AirScale RRH 4T4R B5 160W AHCA					
RRH - 1900 band (QTY/MODEL)				1	AirScale Dual RRH 4T4R B25/66 320W AHFIB		
RRH - AWS band (QTY/MODEL)				1	RRH is shared with another band		
RRH - WCS band (QTY/MODEL)	1	RRH4x25-WCS-4R					
Additional RRH #1 - any band (QTY/MODEL)						1	integrated within: AirScale MAA 64T64R 192AE n77 200W AEQK
Additional RRH #2 - any band (QTY/MODEL)							integrated within: AirScale MAA 64T64R 192AE n77 200W AEQU
RRH 7B 1 (QTY/MODEL)							
RRH 7B 2 (QTY/MODEL)							
RRH 7B 3 (QTY/MODEL)							
Additional Component 1 (QTY/MODEL)							
Additional Component 2 (QTY/MODEL)							
Additional Component 3 (QTY/MODEL)							
Local Market Note 1	ELECTRICAL TILTS: N005(02) , WCS(02) , L7(02) , L7_PS(02) , L9(02) , L2(02) , N002(02) , N066(02) , L2_1(02) , N077(00) , N077_1(00) ERP: N005(463) , WCS(3672) , L7(3228) , L7_PS(3228) , L9(4897) , L2(2741) , N002(0) , N066(0) , L2_1(2741) , N077(34276) , N077_1(34276)						
Local Market Note 2	ANTENNA PORTS: N005(7c+7d+7g+7h) , WCS(7i+7j+7k+7l) , L7(10c+10d+10g+10h) , L7_PS(10c+10d+10g+10h) , L9(10a+10b+10e+10f) , L2(10a+10b+10e+10f) , N002(10a+10b+10e+10f) , N066(10a+10b+10e+10f) , L2_1(10a+10b+10e+10f) , N077(11a+11b) , N077_1(12a+12b)						
Local Market Note 3	SECTOR NAME: N005(WAWN003055_N005A_1) , WCS(WAL03055_3A_1) , L7(WAL03055_7A_1) , L7_PS(WAL03055_7A_2_F) , L9(WAL03055_9A_1) , L2(WAL03055_2A_1) , N002(WAWN003055_N002A_1) , N066(WAWN003055_N066A_1) , L2_1(WAL03055_2A_2) , N077(WAWN003055_N077A_1) , N077_1(WAWN003055_N077A_2)						

PORT SPECIFIC FIELDS	PORT NUMBER	USEID (CSSng)	USEID (Atoll)	ATOLL TXID	ATOLL CELL ID	TX/RX ?	TECHNOLOGY/FREQUENCY	ANTENNA ATOLL	ANTENNA GAIN	ELECTRICAL AZIMUTH	ELECTRICAL TILT	RRH LOCATION (Top/Bottom/Integrated/None)	FEEDERS TYPE	FEEDER LENGTH (feet)	RXAIT KIT MODULE?	TRIPLEXER or LLC (QTY)	TRIPLEXER or LLC (MODEL)	SCPA/MCPA MODULE?	HATCHPLATE POWER (Watts)	ERP (Watts)	Antenna RET Name	CABLE NUMBER	CABLE ID (CSSNG)
ANTENNA POSITION 1	PORT 1	75153.A.850.5G.1		WAWN003055_N005A_1	WAWN003055_N005A_1		5G 850	EPBQ-654L8H8-L2_851MHZ_02DT	16		2	Top	FIBER	100						463			

PRCT120230490

ANTENNA POSITION 3	PORT 2	75153.A.850.5G.1		WAWN003055_N005 A_1	WAWN003055_N005 A_1	5G 850	EPBQ-654LBH8- L2_851MHz_02DT	16		2	Top	FIBER	100							463			
	PORT 3	75153.A.850.5G.1		WAWN003055_N005 A_1	WAWN003055_N005 A_1	5G 850	EPBQ-654LBH8- L2_851MHz_02DT	16		2	Top	FIBER	100							463			
	PORT 4	75153.A.850.5G.1		WAWN003055_N005 A_1	WAWN003055_N005 A_1	5G 850	EPBQ-654LBH8- L2_851MHz_02DT	16		2	Top	FIBER	100							463			
	PORT 9	75153.A.WCS.4G.1		WAL03055_3A_1	WAL03055_3A_1	LTE WCS	EPBQ-654LBH8- L2_2355MHz_02DT	18		2	Top	FIBER	106							3672			
	PORT 10	75153.A.WCS.4G.1		WAL03055_3A_1	WAL03055_3A_1	LTE WCS	EPBQ-654LBH8- L2_2355MHz_02DT	18		2	Top	FIBER	106							3672			
	PORT 11	75153.A.WCS.4G.1		WAL03055_3A_1	WAL03055_3A_1	LTE WCS	EPBQ-654LBH8- L2_2355MHz_02DT	18		2	Top	FIBER	106							3672			
	PORT 12	75153.A.WCS.4G.1		WAL03055_3A_1	WAL03055_3A_1	LTE WCS	EPBQ-654LBH8- L2_2355MHz_02DT	18		2	Top	FIBER	106							3672			
ANTENNA POSITION 4	PORT 1	75153.A.700.4G.1, 75153.A.700.4G.1		WAL03055_7A_1, WAL03055_7A_2_F	WAL03055_7A_1, WAL03055_7A_2_F	LTE 700	EPBQ-654LBH8- L2_722MHz_02DT	15		2	Top	FIBER	106							6456			
	PORT 2	75153.A.700.4G.1, 75153.A.700.4G.1		WAL03055_7A_1, WAL03055_7A_2_F	WAL03055_7A_1, WAL03055_7A_2_F	LTE 700	EPBQ-654LBH8- L2_722MHz_02DT	15		2	Top	FIBER	106							6456			
	PORT 3	75153.A.700.4G.1, 75153.A.700.4G.1		WAL03055_7A_1, WAL03055_7A_2_F	WAL03055_7A_1, WAL03055_7A_2_F	LTE 700	EPBQ-654LBH8- L2_722MHz_02DT	15		2	Top	FIBER	106							6456			
	PORT 4	75153.A.700.4G.1, 75153.A.700.4G.1		WAL03055_7A_1, WAL03055_7A_2_F	WAL03055_7A_1, WAL03055_7A_2_F	LTE 700	EPBQ-654LBH8- L2_722MHz_02DT	15		2	Top	FIBER	106							6456			
	PORT 5	75153.A.1900.4G.1, 75153.A.AWS.4G.1, 75153.A.1900.5G.1*****		WAL03055_9A_1, WAL03055_2A_1, WAWN003055_N002 A_1, WAWN003055_N066 A_1	WAL03055_9A_1, WAL03055_2A_1, WAWN003055_N002 A_1, WAWN003055_N066 A_1, WAL03055_2A_2	LTE 1900.LTE AWS,5G 1900*****	EPBQ-654LBH8- L2_2130MHz_02DT	18		2	Top	FIBER	106							9999			
	PORT 6	75153.A.1900.4G.1, 75153.A.AWS.4G.1, 75153.A.1900.5G.1*****		WAL03055_9A_1, WAL03055_2A_1, WAWN003055_N002 A_1, WAWN003055_N066 A_1	WAL03055_9A_1, WAL03055_2A_1, WAWN003055_N002 A_1, WAWN003055_N066 A_1, WAL03055_2A_2	LTE 1900.LTE AWS,5G 1900*****	EPBQ-654LBH8- L2_2130MHz_02DT	18		2	Top	FIBER	106							9999			
	PORT 7	75153.A.1900.4G.1, 75153.A.AWS.4G.1, 75153.A.1900.5G.1*****		WAL03055_9A_1, WAL03055_2A_1, WAWN003055_N002 A_1, WAWN003055_N066 A_1	WAL03055_9A_1, WAL03055_2A_1, WAWN003055_N002 A_1, WAWN003055_N066 A_1, WAL03055_2A_2	LTE 1900.LTE AWS,5G 1900*****	EPBQ-654LBH8- L2_2130MHz_02DT	18		2	Top	FIBER	106							9999			
	PORT 8	75153.A.1900.4G.1, 75153.A.AWS.4G.1, 75153.A.1900.5G.1*****		WAL03055_9A_1, WAL03055_2A_1, WAWN003055_N002 A_1, WAWN003055_N066 A_1	WAL03055_9A_1, WAL03055_2A_1, WAWN003055_N002 A_1, WAWN003055_N066 A_1, WAL03055_2A_2	LTE 1900.LTE AWS,5G 1900*****	EPBQ-654LBH8- L2_2130MHz_02DT	18		2	Top	FIBER	106							9999			
ANTENNA POSITION 5	PORT 3	75153.A.CBAND.5G.1		WAWN003055_N077 A_1	WAWN003055_N077 A_1	5G CBAND		24		0		FIBER	0						9999				
	PORT 4	75153.A.CBAND.5G.1		WAWN003055_N077 A_1	WAWN003055_N077 A_1	5G CBAND		24		0		FIBER	0							9999			
ANTENNA POSITION 6	PORT 3	75153.A.CBAND.5G.2		WAWN003055_N077 A_2	WAWN003055_N077 A_2	5G DoD		24		0		FIBER	0						9999				
	PORT 4	75153.A.CBAND.5G.2		WAWN003055_N077 A_2	WAWN003055_N077 A_2	5G DoD		24		0		FIBER	0							9999			

ANTENNA POSITION is LEFT to RIGHT from BACK OF ANTENNA (unless otherwise specified)	ANTENNA POSITION 1	ANTENNA POSITION 2	ANTENNA POSITION 3	ANTENNA POSITION 4	ANTENNA POSITION 5	ANTENNA POSITION 6	ANTENNA POSITION 7
ANTENNA MAKE - MODEL	EPBQ-654L8H8-L2			EPBQ-654L8H8-L2	AEQK	AEQU	
ANTENNA VENDOR	KMW			KMW	Nokia	Nokia	
ANTENNA SIZE (H x W x D)	96X21X6.3			96X21X6.3	29.5X17.7X9.5	29.5X17.7X9.5	
ANTENNA WEIGHT	86			86	99.2	99.2	
AZIMUTH	215			215	215	215	
MAGNETIC DECLINATION							
RADIATION CENTER (feet)	80			80	88.75	88.75	
ANTENNA TIP HEIGHT	84			84	90	90	
MECHANICAL DOWNTILT	2			2	0	0	
FEEDER AMOUNT	0			0	0	0	
VERTICAL SEPARATION from ANTENNA ABOVE (TIP to TIP)							
VERTICAL SEPARATION from ANTENNA BELOW (TIP to TIP)							
HORIZONTAL SEPARATION from CLOSEST ANTENNA to LEFT (CENTERLINE to CENTERLINE)							
HORIZONTAL SEPARATION from CLOSEST ANTENNA to RIGHT (CENTERLINE to CENTERLINE)							
HORIZONTAL SEPARATION from ANOTHER ANTENNA (which antenna # / # of inches)							
Antenna RET Motor (QTY/MODEL)							
SURGE ARRESTOR (QTY/MODEL)							
DIPLEXER (QTY/MODEL)							
DUPLEXER (QTY/MODEL)							
Antenna RET CONTROL UNIT (QTY/MODEL)							
DC BLOCK (QTY/MODEL)							
TMA/LNA (QTY/MODEL)							
CURRENT INJECTORS FOR TMA (QTY/MODEL)							
PDU FOR TMA (QTY/MODEL)							
FILTER (QTY/MODEL)							
SQUID (QTY/MODEL)	3	DC2-48-60-0-9E					
FIBER TRUNK (QTY/MODEL)							
DC TRUNK (QTY/MODEL)							
REPEATER (QTY/MODEL)							
RRH - 700 band (QTY/MODEL)				1	AirScale Dual RRH 4T4R B12/14 320W AHLBA		
RRH - 850 band (QTY/MODEL)	1	AirScale RRH 4T4R B5 160W AHCA					
RRH - 1900 band (QTY/MODEL)				1	AirScale Dual RRH 4T4R B25/66 320W AHFIB		
RRH - AWS band (QTY/MODEL)				1	RRH is shared with another band		
RRH - WCS band (QTY/MODEL)	1	RRH4x25-WCS-4R					
Additional RRH #1 - any band (QTY/MODEL)						1	integrated within: AirScale MAA 64T64R 192AE n77 200W AEQK
Additional RRH #2 - any band (QTY/MODEL)							integrated within: AirScale MAA 64T64R 192AE n77 200W AEQU
RRH 7B 1 (QTY/MODEL)							
RRH 7B 2 (QTY/MODEL)							
RRH 7B 3 (QTY/MODEL)							
Additional Component 1 (QTY/MODEL)							
Additional Component 2 (QTY/MODEL)							
Additional Component 3 (QTY/MODEL)							
Local Market Note 1	ELECTRICAL TILTS: N005(02) , WCS(02) , L7(04) , L7_PS(04) , L9(02) , L2(02) , N002(02) , N066(02) , L2_1(02) , N077(00) , N077_1(00) ERP: N005(463) , WCS(3672) , L7(3303) , L7_PS(3303) , L9(4897) , L2(2741) , N002(0) , N066(0) , L2_1(2741) , N077(34276) , N077_1(34276)						
Local Market Note 2	ANTENNA PORTS: N005(13c+13d+13g+13h) , WCS(13h+13j+13k+13l) , L7(16c+16d+16g+16h) , L7_PS(16c+16d+16g+16h) , L9(16a+16b+16e+16f) , L2(16a+16b+16e+16f) , N002(16a+16b+16e+16f) , N066(16a+16b+16e+16f) , L2_1(16a+16b+16e+16f) , N077(17a+17b) , N077_1(18a+18b)						
Local Market Note 3	SECTOR NAME: N005(WAWN003055_N005B_1) , WCS(WAL03055_3B_1) , L7(WAL03055_7B_1) , L7_PS(WAL03055_7B_2_F) , L9(WAL03055_9B_1) , L2(WAL03055_2B_1) , N002(WAWN003055_N002B_1) , N066(WAWN003055_N066B_1) , L2_1(WAL03055_2B_2) , N077(WAWN003055_N077B_1) , N077_1(WAWN003055_N077B_2)						

PORT SPECIFIC FIELDS	PORT NUMBER	USEID (CSSng)	USEID (Atoll)	ATOLL TXID	ATOLL CELL ID	TX/RX ?	TECHNOLOGY/FREQUENCY	ANTENNA ATOLL	ANTENNA GAIN	ELECTRICAL AZIMUTH	ELECTRICAL TILT	RRH LOCATION (Top/Bottom/Integrated/None)	FEEDERS TYPE	FEEDER LENGTH (feet)	RXAIT KIT MODULE?	TRIPLEXER or LLC (QTY)	TRIPLEXER or LLC (MODEL)	SCPA/MCPA MODULE?	HATCHPLATE POWER (Watts)	ERP (Watts)	Antenna RET Name	CABLE NUMBER	CABLE ID (CSSNG)
ANTENNA POSITION 1	PORT 1	75153.B.850.5G.1		WAWN003055_N005B_1	WAWN003055_N005B_1		5G 850	EPBQ-654L8H8-L2_851MHZ_02DT	16		2	Top	FIBER	100						463			

PRCTI20230490

	PORT 2	75153.B.850.5G.1		WAWN003055_N005_B_1	WAWN003055_N005_B_1	5G 850	EPBQ-654LBH8-L2_851MHz_02DT	16		2	Top	FIBER	100						463					
	PORT 3	75153.B.850.5G.1		WAWN003055_N005_B_1	WAWN003055_N005_B_1	5G 850	EPBQ-654LBH8-L2_851MHz_02DT	16		2	Top	FIBER	100						463					
	PORT 4	75153.B.850.5G.1		WAWN003055_N005_B_1	WAWN003055_N005_B_1	5G 850	EPBQ-654LBH8-L2_851MHz_02DT	16		2	Top	FIBER	100						463					
	PORT 9	75153.B.WCS.4G.1		WAL03055_3B_1	WAL03055_3B_1	LTE WCS	EPBQ-654LBH8-L2_2355MHz_02DT	18		2	Top	FIBER	106						3672					
	PORT 10	75153.B.WCS.4G.1		WAL03055_3B_1	WAL03055_3B_1	LTE WCS	EPBQ-654LBH8-L2_2355MHz_02DT	18		2	Top	FIBER	106						3672					
	PORT 11	75153.B.WCS.4G.1		WAL03055_3B_1	WAL03055_3B_1	LTE WCS	EPBQ-654LBH8-L2_2355MHz_02DT	18		2	Top	FIBER	106						3672					
	PORT 12	75153.B.WCS.4G.1		WAL03055_3B_1	WAL03055_3B_1	LTE WCS	EPBQ-654LBH8-L2_2355MHz_02DT	18		2	Top	FIBER	106						3672					
	PORT 1	75153.B.700.4G.1, 75153.B.700.4G.1		WAL03055_7B_1, WAL03055_7B_2_F	WAL03055_7B_1, WAL03055_7B_2_F	LTE 700	EPBQ-654LBH8-L2_722MHz_04DT	15		4	Top	FIBER	106						6606					
	PORT 2	75153.B.700.4G.1, 75153.B.700.4G.1		WAL03055_7B_1, WAL03055_7B_2_F	WAL03055_7B_1, WAL03055_7B_2_F	LTE 700	EPBQ-654LBH8-L2_722MHz_04DT	15		4	Top	FIBER	106						6606					
	PORT 3	75153.B.700.4G.1, 75153.B.700.4G.1		WAL03055_7B_1, WAL03055_7B_2_F	WAL03055_7B_1, WAL03055_7B_2_F	LTE 700	EPBQ-654LBH8-L2_722MHz_04DT	15		4	Top	FIBER	106						6606					
	PORT 4	75153.B.700.4G.1, 75153.B.700.4G.1		WAL03055_7B_1, WAL03055_7B_2_F	WAL03055_7B_1, WAL03055_7B_2_F	LTE 700	EPBQ-654LBH8-L2_722MHz_04DT	15		4	Top	FIBER	106						6606					
	PORT 5	75153.B.1900.4G.1, 75153.B.AWS.4G.1, 75153.B.1900.5G.1*****		WAL03055_9B_1, WAL03055_2B_1, WAWN003055_N002_B_1, WAWN003055_N066_B_1	WAL03055_9B_1, WAL03055_2B_1, WAWN003055_N002_B_1, WAWN003055_N066_B_1, WAL03055_2B_2	LTE 1900.LTE AWS,5G 1900*****	EPBQ-654LBH8-L2_2130MHz_02DT	18		2	Top	FIBER	106						9999					
ANTENNA POSITION 4	PORT 6	75153.B.1900.4G.1, 75153.B.AWS.4G.1, 75153.B.1900.5G.1*****		WAL03055_9B_1, WAL03055_2B_1, WAWN003055_N002_B_1, WAWN003055_N066_B_1	WAL03055_9B_1, WAL03055_2B_1, WAWN003055_N002_B_1, WAWN003055_N066_B_1, WAL03055_2B_2	LTE 1900.LTE AWS,5G 1900*****	EPBQ-654LBH8-L2_2130MHz_02DT	18		2	Top	FIBER	106						9999					
	PORT 7	75153.B.1900.4G.1, 75153.B.AWS.4G.1, 75153.B.1900.5G.1*****		WAL03055_9B_1, WAL03055_2B_1, WAWN003055_N002_B_1, WAWN003055_N066_B_1	WAL03055_9B_1, WAL03055_2B_1, WAWN003055_N002_B_1, WAWN003055_N066_B_1, WAL03055_2B_2	LTE 1900.LTE AWS,5G 1900*****	EPBQ-654LBH8-L2_2130MHz_02DT	18		2	Top	FIBER	106						9999					
	PORT 8	75153.B.1900.4G.1, 75153.B.AWS.4G.1, 75153.B.1900.5G.1*****		WAL03055_9B_1, WAL03055_2B_1, WAWN003055_N002_B_1, WAWN003055_N066_B_1	WAL03055_9B_1, WAL03055_2B_1, WAWN003055_N002_B_1, WAWN003055_N066_B_1, WAL03055_2B_2	LTE 1900.LTE AWS,5G 1900*****	EPBQ-654LBH8-L2_2130MHz_02DT	18		2	Top	FIBER	106						9999					
ANTENNA POSITION 5	PORT 3	75153.B.CBAND.5G.1		WAWN003055_N077_B_1	WAWN003055_N077_B_1	5G CBAND		24		0		FIBER	0					9999						
	PORT 4	75153.B.CBAND.5G.1		WAWN003055_N077_B_1	WAWN003055_N077_B_1	5G CBAND		24		0		FIBER	0						9999					
ANTENNA POSITION 6	PORT 3	75153.B.CBAND.5G.2		WAWN003055_N077_B_2	WAWN003055_N077_B_2	5G DoD		24		0		FIBER	0					9999						
	PORT 4	75153.B.CBAND.5G.2		WAWN003055_N077_B_2	WAWN003055_N077_B_2	5G DoD		24		0		FIBER	0						9999					

ANTENNA POSITION is LEFT to RIGHT from BACK OF ANTENNA (unless otherwise specified)	ANTENNA POSITION 1	ANTENNA POSITION 2	ANTENNA POSITION 3	ANTENNA POSITION 4	ANTENNA POSITION 5	ANTENNA POSITION 6	ANTENNA POSITION 7
ANTENNA MAKE - MODEL	EPBQ-654L8H8-L2			EPBQ-654L8H8-L2	AEQK	AEQU	
ANTENNA VENDOR	KMW			KMW	Nokia	Nokia	
ANTENNA SIZE (H x W x D)	96X21X6.3			96X21X6.3	29.5X17.7X9.5	29.5X17.7X9.5	
ANTENNA WEIGHT	86			86	99.2	99.2	
AZIMUTH	315			315	315	315	
MAGNETIC DECLINATION							
RADIATION CENTER (feet)	80			80	88.75	88.75	
ANTENNA TIP HEIGHT	84			84	90	90	
MECHANICAL DOWNTILT	2			2	0	0	
FEEDER AMOUNT	0			0	0	0	
VERTICAL SEPARATION from ANTENNA ABOVE (TIP to TIP)							
VERTICAL SEPARATION from ANTENNA BELOW (TIP to TIP)							
HORIZONTAL SEPARATION from CLOSEST ANTENNA to LEFT (CENTERLINE to CENTERLINE)							
HORIZONTAL SEPARATION from CLOSEST ANTENNA to RIGHT (CENTERLINE to CENTERLINE)							
HORIZONTAL SEPARATION from ANOTHER ANTENNA (which antenna # / # of inches)							
Antenna RET Motor (QTY/MODEL)							
SURGE ARRESTOR (QTY/MODEL)							
DIPLEXER (QTY/MODEL)							
DUPLEXER (QTY/MODEL)							
Antenna RET CONTROL UNIT (QTY/MODEL)							
DC BLOCK (QTY/MODEL)							
TMA/LNA (QTY/MODEL)							
CURRENT INJECTORS FOR TMA (QTY/MODEL)							
PDU FOR TMA (QTY/MODEL)							
FILTER (QTY/MODEL)							
SQUID (QTY/MODEL)	3	DC2-48-60-0-9E					
FIBER TRUNK (QTY/MODEL)							
DC TRUNK (QTY/MODEL)							
REPEATER (QTY/MODEL)							
RRH - 700 band (QTY/MODEL)				1	AirScale Dual RRH 4T4R B12/14 320W AHLBA		
RRH - 850 band (QTY/MODEL)	1	AirScale RRH 4T4R B5 160W AHCA					
RRH - 1900 band (QTY/MODEL)				1	AirScale Dual RRH 4T4R B25/66 320W AHFIB		
RRH - AWS band (QTY/MODEL)				1	RRH is shared with another band		
RRH - WCS band (QTY/MODEL)	1	RRH4x25-WCS-4R					
Additional RRH #1 - any band (QTY/MODEL)						1	integrated within: AirScale MAA 64T64R 192AE n77 200W AEQK
Additional RRH #2 - any band (QTY/MODEL)							integrated within: AirScale MAA 64T64R 192AE n77 200W AEQU
RRH 7B 1 (QTY/MODEL)							
RRH 7B 2 (QTY/MODEL)							
RRH 7B 3 (QTY/MODEL)							
Additional Component 1 (QTY/MODEL)							
Additional Component 2 (QTY/MODEL)							
Additional Component 3 (QTY/MODEL)							
Local Market Note 1	ELECTRICAL TILTS: N005(02) , WCS(02) , L7(02) , L7_PS(02) , L9(03) , L2(03) , N002(02) , N066(03) , L2_1(03) , N077(00) , N077_1(00) ERP: N005(463) , WCS(3672) , L7(3228) , L7_PS(3228) , L9(5011) , L2(2741) , N002(0) , N066(0) , L2_1(2741) , N077(34276) , N077_1(34276)						
Local Market Note 2	ANTENNA PORTS: N005(1c+1d+1g+1h) , WCS(1i+1j+1k+1l) , L7(4c+4d+4g+4h) , L7_PS(4c+4d+4g+4h) , L9(4a+4b+4e+4f) , L2(4a+4b+4e+4f) , N002(4a+4b+4e+4f) , N066(4a+4b+4e+4f) , L2_1(4a+4b+4e+4f) , N077(5a+5b) , N077_1(6a+6b)						
Local Market Note 3	SECTOR NAME: N005(WAWN003055_N005C_1) , WCS(WAL03055_3C_1) , L7(WAL03055_7C_1) , L7_PS(WAL03055_7C_2_F) , L9(WAL03055_9C_1) , L2(WAL03055_2C_1) , N002(WAWN003055_N002C_1) , N066(WAWN003055_N066C_1) , L2_1(WAL03055_2C_2) , N077(WAWN003055_N077C_1) , N077_1(WAWN003055_N077C_2)						

PORT SPECIFIC FIELDS	PORT NUMBER	USEID (CSSng)	USEID (Atoll)	ATOLL TXID	ATOLL CELL ID	TX/RX ?	TECHNOLOGY/FREQUENCY	ANTENNA ATOLL	ANTENNA GAIN	ELECTRICAL AZIMUTH	ELECTRICAL TILT	RRH LOCATION (Top/Bottom/Integrated/None)	FEEDERS TYPE	FEEDER LENGTH (feet)	RXAIT KIT MODULE?	TRIPLEXER or LLC (QTY)	TRIPLEXER or LLC (MODEL)	SCPA/MCPA MODULE?	HATCHPLATE POWER (Watts)	ERP (Watts)	Antenna RET Name	CABLE NUMBER	CABLE ID (CSSNG)
ANTENNA POSITION 1	PORT 1	75153.C.850.5G.1		WAWN003055_N005C_1	WAWN003055_N005C_1		5G 850	EPBQ-654L8H8-L2_851MHZ_02DT	16		2	Top	FIBER	100						463			

PRCTI20230490

ANTENNA POSITION 3	PORT 2	75153.C.850.5G.1		WAWN003055_N005 C_1	WAWN003055_N005 C_1	5G 850	EPBQ-654LBH8-L2_851MHz_02DT	16		2	Top	FIBER	100						463			
	PORT 3	75153.C.850.5G.1		WAWN003055_N005 C_1	WAWN003055_N005 C_1	5G 850	EPBQ-654LBH8-L2_851MHz_02DT	16		2	Top	FIBER	100						463			
	PORT 4	75153.C.850.5G.1		WAWN003055_N005 C_1	WAWN003055_N005 C_1	5G 850	EPBQ-654LBH8-L2_851MHz_02DT	16		2	Top	FIBER	100						463			
	PORT 9	75153.C.WCS.4G.1		WAL03055_3C_1	WAL03055_3C_1	LTE WCS	EPBQ-654LBH8-L2_2355MHz_02DT	18		2	Top	FIBER	106						3672			
	PORT 10	75153.C.WCS.4G.1		WAL03055_3C_1	WAL03055_3C_1	LTE WCS	EPBQ-654LBH8-L2_2355MHz_02DT	18		2	Top	FIBER	106						3672			
	PORT 11	75153.C.WCS.4G.1		WAL03055_3C_1	WAL03055_3C_1	LTE WCS	EPBQ-654LBH8-L2_2355MHz_02DT	18		2	Top	FIBER	106						3672			
	PORT 12	75153.C.WCS.4G.1		WAL03055_3C_1	WAL03055_3C_1	LTE WCS	EPBQ-654LBH8-L2_2355MHz_02DT	18		2	Top	FIBER	106						3672			
ANTENNA POSITION 4	PORT 1	75153.C.700.4G.1, 75153.C.700.4G.1		WAL03055_7C_1, WAL03055_7C_2_F	WAL03055_7C_1, WAL03055_7C_2_F	LTE 700	EPBQ-654LBH8-L2_722MHz_02DT	15		2	Top	FIBER	106						6456			
	PORT 2	75153.C.700.4G.1, 75153.C.700.4G.1		WAL03055_7C_1, WAL03055_7C_2_F	WAL03055_7C_1, WAL03055_7C_2_F	LTE 700	EPBQ-654LBH8-L2_722MHz_02DT	15		2	Top	FIBER	106						6456			
	PORT 3	75153.C.700.4G.1, 75153.C.700.4G.1		WAL03055_7C_1, WAL03055_7C_2_F	WAL03055_7C_1, WAL03055_7C_2_F	LTE 700	EPBQ-654LBH8-L2_722MHz_02DT	15		2	Top	FIBER	106						6456			
	PORT 4	75153.C.700.4G.1, 75153.C.700.4G.1		WAL03055_7C_1, WAL03055_7C_2_F	WAL03055_7C_1, WAL03055_7C_2_F	LTE 700	EPBQ-654LBH8-L2_722MHz_02DT	15		2	Top	FIBER	106						6456			
	PORT 5	75153.C.1900.4G.1, 75153.C.AWS.4G.1, 75153.C.1900.5G.1*****		WAL03055_9C_1, WAL03055_2C_1, WAWN003055_N002 C_1, WAWN003055_N066 C_1	WAL03055_9C_1, WAL03055_2C_1, WAWN003055_N002 C_1, WAWN003055_N066 C_1, WAL03055_2C_2	LTE 1900.LTE AWS,5G 1900*****	EPBQ-654LBH8-L2_2130MHz_03DT	18		3	Top	FIBER	106						9999			
	PORT 6	75153.C.1900.4G.1, 75153.C.AWS.4G.1, 75153.C.1900.5G.1*****		WAL03055_9C_1, WAL03055_2C_1, WAWN003055_N002 C_1, WAWN003055_N066 C_1	WAL03055_9C_1, WAL03055_2C_1, WAWN003055_N002 C_1, WAWN003055_N066 C_1, WAL03055_2C_2	LTE 1900.LTE AWS,5G 1900*****	EPBQ-654LBH8-L2_2130MHz_03DT	18		3	Top	FIBER	106						9999			
	PORT 7	75153.C.1900.4G.1, 75153.C.AWS.4G.1, 75153.C.1900.5G.1*****		WAL03055_9C_1, WAL03055_2C_1, WAWN003055_N002 C_1, WAWN003055_N066 C_1	WAL03055_9C_1, WAL03055_2C_1, WAWN003055_N002 C_1, WAWN003055_N066 C_1, WAL03055_2C_2	LTE 1900.LTE AWS,5G 1900*****	EPBQ-654LBH8-L2_2130MHz_03DT	18		3	Top	FIBER	106						9999			
	PORT 8	75153.C.1900.4G.1, 75153.C.AWS.4G.1, 75153.C.1900.5G.1*****		WAL03055_9C_1, WAL03055_2C_1, WAWN003055_N002 C_1, WAWN003055_N066 C_1	WAL03055_9C_1, WAL03055_2C_1, WAWN003055_N002 C_1, WAWN003055_N066 C_1, WAL03055_2C_2	LTE 1900.LTE AWS,5G 1900*****	EPBQ-654LBH8-L2_2130MHz_03DT	18		3	Top	FIBER	106						9999			
ANTENNA POSITION 5	PORT 3	75153.C.CBAND.5G.1		WAWN003055_N077 C_1	WAWN003055_N077 C_1	5G CBAND		24		0		FIBER	0					9999				
	PORT 4	75153.C.CBAND.5G.1		WAWN003055_N077 C_1	WAWN003055_N077 C_1	5G CBAND		24		0		FIBER	0					9999				
ANTENNA POSITION 6	PORT 3	75153.C.CBAND.5G.2		WAWN003055_N077 C_2	WAWN003055_N077 C_2	5G DoD		24		0		FIBER	0					9999				
	PORT 4	75153.C.CBAND.5G.2		WAWN003055_N077 C_2	WAWN003055_N077 C_2	5G DoD		24		0		FIBER	0					9999				

Comments:

Sector A,B&C

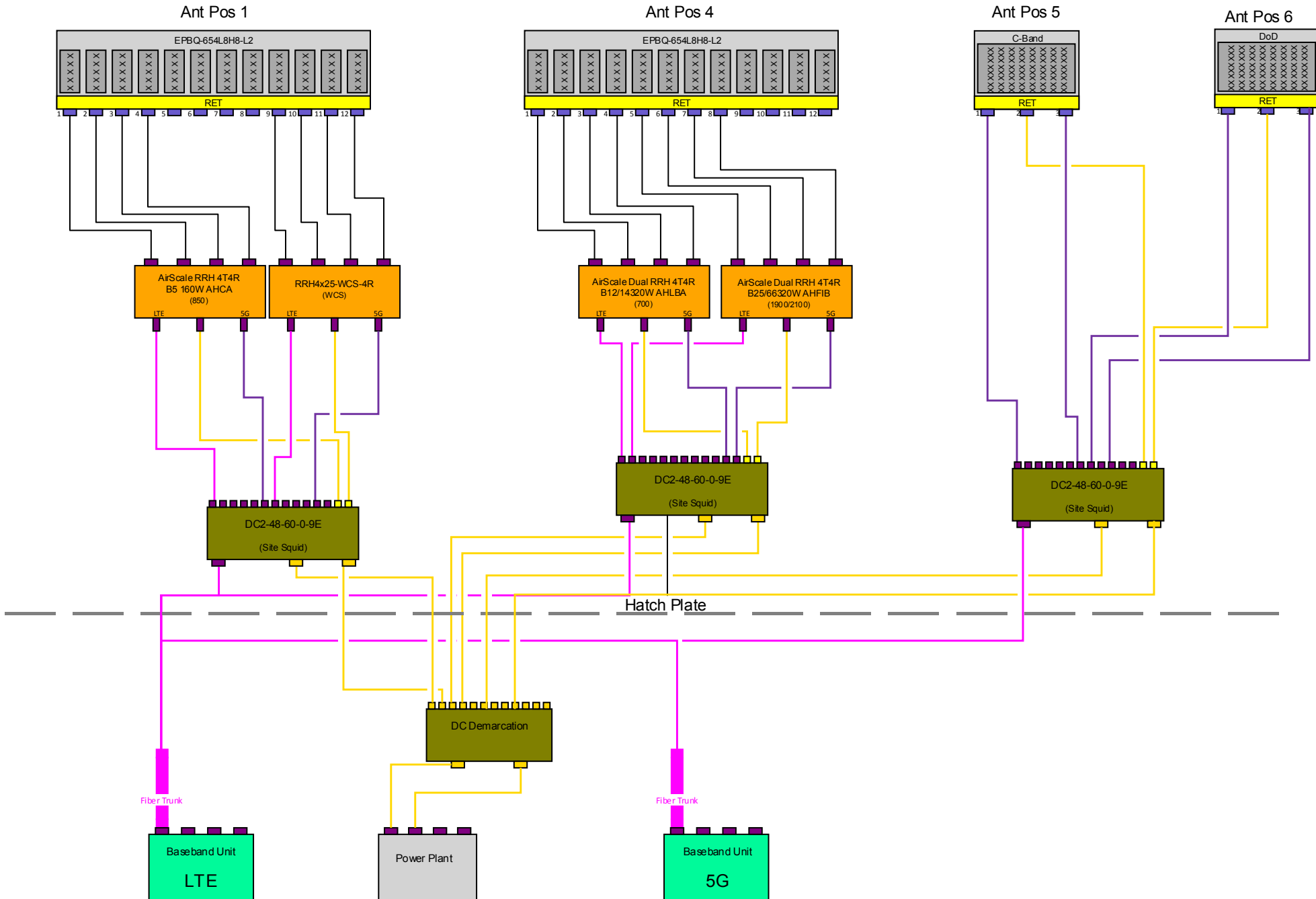

Comments:

Sector A,B&C

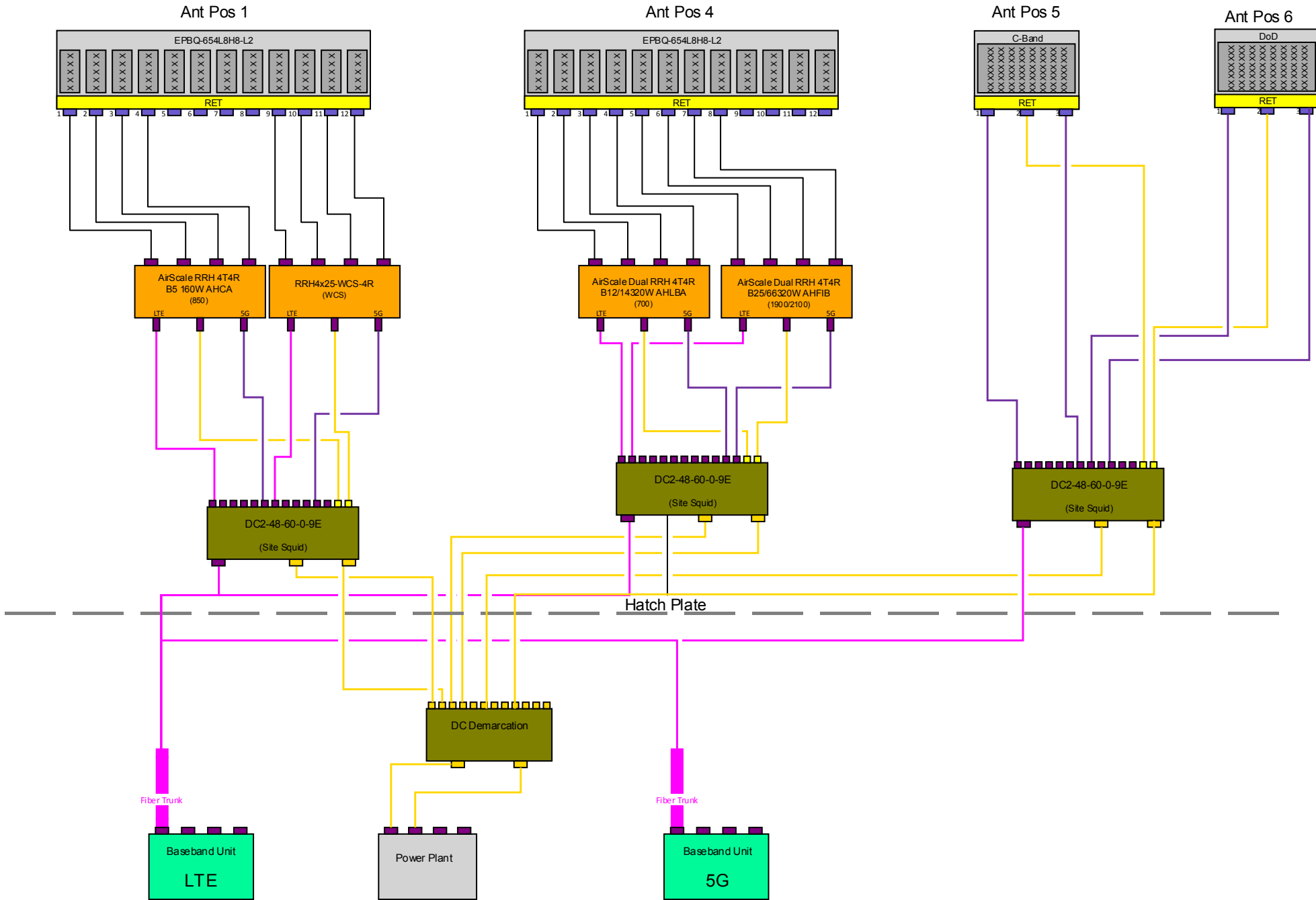

Comments:

Sector A,B&C

