



Froula Alarm Systems, Inc.

861 Industry Drive ♦ Tukwila WA 98188-3411

Phone: 206-575-1962 ♦ Fax: 206-575-8168

---

August 18, 2023

# Fire Alarm System

## Submittals

For

**GSMOB**

**3<sup>rd</sup> Floor Phase 2**

**Women's Clinic Tenant Improvement**

**1450 – 5<sup>th</sup> Street SE**

**Puyallup, Washington 98372**

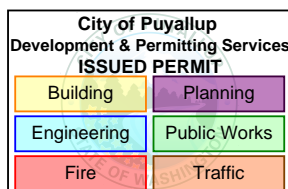

HOWARD WILLIAMSON, SET

NICET #82289

FIRE ALARM SYSTEMS

LEVEL IV

*Howard Williamson*



## Froula Alarm Systems, Inc.

861 Industry Drive ♦ Tukwila WA 98188-3411

Phone: 206-575-1962 ♦ Fax: 206-575-8168

---

### GSMOB 3<sup>rd</sup> Floor Phase 2 Women's Clinic Tenant Improvement

August 18, 2023

#### Table of Contents

#### Fire Alarm System

<u>Manufacturer</u>	<u>Model No.</u>	<u>Description</u>
Potter	PSN-106	EXISTING Booster Power Supply
Farenhyt	IDP-Photo-W	Addressable Smoke Detector
Farenhyt	B300-6	Detector Base
System Sensor	SCWL	Multi-Candela Ceiling Mount Strobe

## Features

- PSN-64 has 6 amps regulated with 4 outputs
- PSN-106 has 10 amps regulated with 6 outputs
- May be configured as up to three class “A” Style “Z” notification circuits
- Two Trouble relays (5A at 30VDC) General System Trouble (programmable for AC delay) Low AC Trouble with optional delay settings
- Diagnostic LED’s Status LED’s for Active NAC and NAC Trouble conditions.
- Quadrasync feature synchronizes strobes from AMSECO, Gentex, Cooper-Wheelock and System Sensor.
- Configurable output circuits (DIP switch sets options for each circuit)
- Reference EOL allows 2K – 27K EOL value to be used
- Pass Thru mode allows the outputs to match the input signal from FACP



## Description

The PSN series of notification power supplies offers reliable notification power with unprecedented versatility. The power supplies offer either 6 or 10 amps of continuous power through 4 or 6 outputs respectively. Each output is rated at 3 amps and it may be used continuously without any derating. The power supply operates on either 120 VAC or 220 VAC power input and has a regulated 24 VDC output. In addition, the power supply can charge up to 55 AH batteries and leads the industry in housing up to 18 AH batteries. The cabinet is constructed out of 18 gauge cold rolled steel and has a durable red powder coat finish. In addition, a key lock is provided for securing the door. Ample electrical knockouts are provided on the sides and the top, allowing the installer options for running wires and maintaining the correct separations.

The power supply offers an industry leading Quadrasync function that allows for multiple strobe circuits of different brands to be synchronized to flash at the same time. The power supply can have four different brands each connected to its own circuit and all the strobes flash together. Each output can independently be configured to provide one of four synchronizations or steady power. This provides unequivocal flexibility in new and retrofit installations. The power supply can be configured to synchronize AMSECO®, Gentex®, Wheelock® and System Sensor® strobe devices. Each output can be configured to the same sync protocol or set independently. In addition, the power supply has an input Pass Thru mode which allows the outputs to follow the input signal from a non-supported synchronization protocol. The power supply will recognize the type of input being supplied and pass this through to the outputs with

the same pattern. This input pass through can be selected on each output independently. The power supply contains simple dipswitch programming and LED indicators providing the installer the ability to correct any possible faults. A Trouble Memory is provided to allow an installer to review past troubles and make the necessary repairs. Each output has an LED to pinpoint the exact circuit where a trouble may have occurred. Relays are provided for monitoring the general system and AC failure. Each output can be independently configured for various applications and installations. Each output can be independently configured for Class A or Class B operation, constant power, ANSI Temporal Code 3, Single, Multiple or Combo Inputs or Door Holder Power.

## Technical Specifications

Size (H x W x D)	16 1/8" W x 16 3/4" W x 3 1/2" D
Enclosure	Eighteen (18) gauge sheet steel with hinged, locked door
Power Input	120VAC @ 60Hz 220/240VAC @ 50Hz 5.1 Amps @ 120 VAC 2.5 Amps @ 240 VAC
Current	75mA Standby & Alarm (no external load)
Input Voltage Trigger	15mA @ 8 – 33 VDC
Terminals	18-12AWG
Temperature	32° F to 120°F (0°C to 49°C) with a maximum humidity of 93% non-condensing
NAC Output	3 Amp max per NAC, Regulated
Battery Charging	27.3 @ 1A, can support 7 – 55Ah batteries

PSN-106 Wiring Diagram

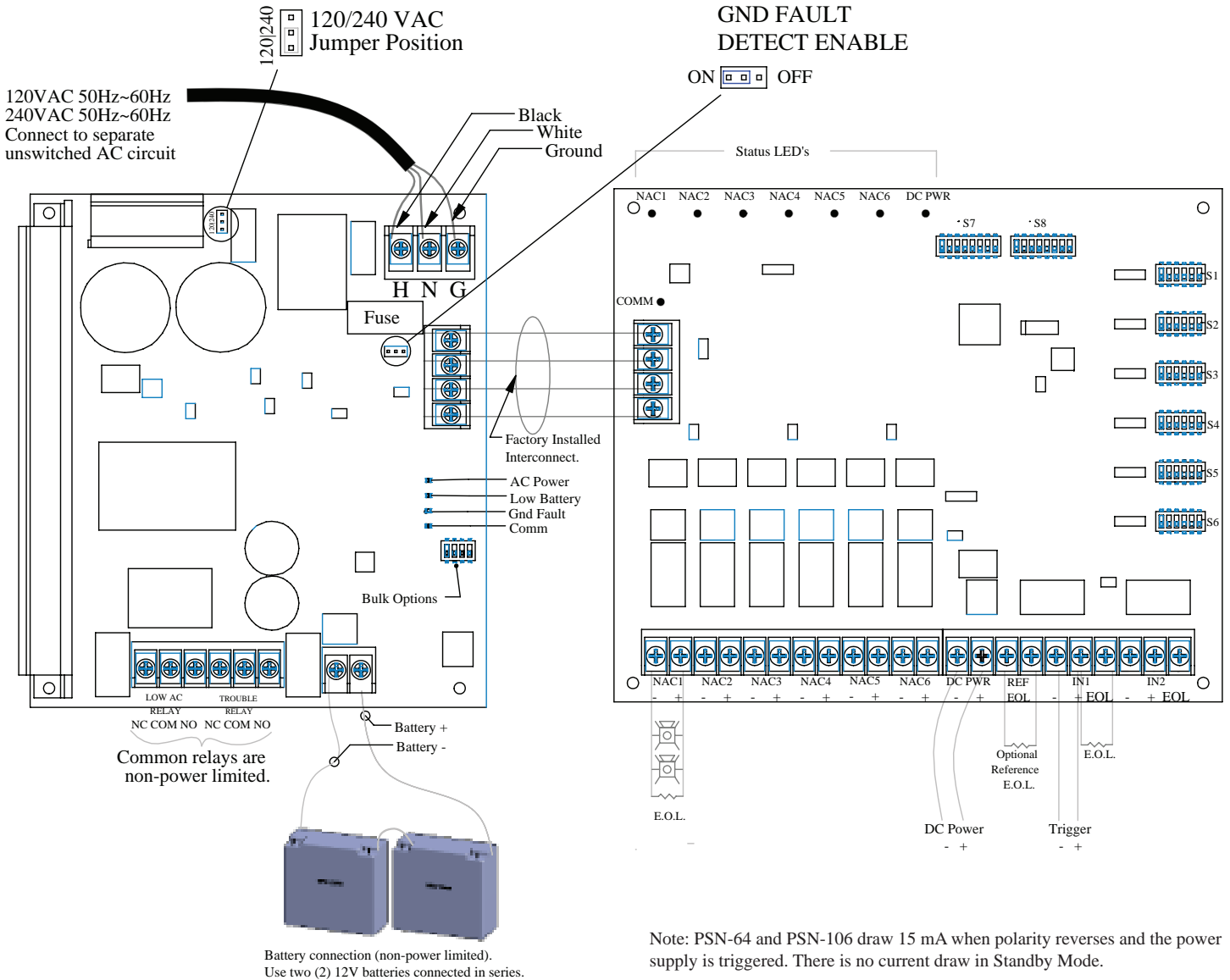

Note: PSN-64 and PSN-106 draw 15 mA when polarity reverses and the power supply is triggered. There is no current draw in Standby Mode.

Ordering Information

Model	Description	Stock No.
PSN-106	10 A Power Supply, 6 NAC Circuits, Red Enclosure	3006437
PSN-106B	10 A Power Supply, 6 NAC Circuits, Black Enclosure	3006446
PSN-64	6 A Power Supply, 4 NAC Circuits, Red Enclosure	3006436

---

---

## Engineering Specifications

The contractor shall supply and install the Potter PSN power supply. The power supply shall operate on either 120 or 240 VAC input. The panel shall be capable of continuous load power without any degradation to the main supply or the distribution board. The cabinet shall be capable of housing up to 18AH batteries and the panel shall be capable of charging up to 55 AH batteries in an external cabinet.

The panel shall have dip switches for simplistic configuration of the system and LEDs to provide visual indication to the installer of the status of the system. The dip switches shall allow for AC power delay selection, Class A/B operation per output, Door Holder Power options, constant auxiliary power, trigger input type, ANSI Code 3 Temporal Code, Pass Thru (input tracking), AMSECO® sync, Gentex® Sync, System Sensor® Sync or Wheelock® sync. The LEDs shall provide indication of communication between the power supply and distribution circuit assemblies. The LEDs shall have distinct flash patterns to provide further indication of the troubles present. The panel shall have selectable Trouble Memory to provide the installer an indication that a past trouble existed on a circuit for diagnostic purposes.

Each output of the power supply shall be capable of 3 amps of continuous power without degradation overtime. The power supply shall provide for multiple circuits of strobe appliances. The power supply shall synchronize the flashes of any of the above listed strobe appliances on a per circuit basis. Up to four different strobe circuits may be connected and all the strobes shall flash in unison as required by UL 864. In addition to this Quadrasync feature, the panel shall allow any of the four above mentioned sync patterns as an input and pass this signal through and synchronize the outputs to match the input flash pattern.

## Farenhyt IDP-PHOTO-W Series

### Intelligent Plug-in Photoelectric Smoke Detectors

Honeywell's IDP-PHOTO-W Series intelligent plug-in smoke detectors are designed for both performance and aesthetics. A new modern, sleek, contemporary design and enhanced optical sensing chamber is engineered to sense smoke produced by a wide range of combustion sources in accordance with more stringent code standards.

The IDP-PHOTO-W Series detector sensitivity can be programmed in the control panel software. Sensitivity is continuously monitored and reported to the panel. Point ID capability allows each detector's address to be set with rotary, decimal address switches, providing exact detector location for selective maintenance when chamber contamination reaches an unacceptable level.

Dual electronic thermistors add 135°F (57°C) fixed temperature thermal sensing on the IDP-PHOTO-T. The IDP-PHOTO-R is a remote test capable detector for use with DNR Series duct detector housings



**IDP-PHOTO-W in B300-6 base**

## FEATURES & BENEFITS

- New modern profile for improved aesthetics
- Stable communication technique with noise immunity
- Low standby current
- Two-wire SLC connection
- Optional remote, single-gang LED accessory
- Dual LED design provides 360° viewing angle
- Remote test feature from the panel
- Built-in functional test switch activated by external magnet
- Built-in tamper-resistant feature
- Sealed against back pressure
- Expanded color options
- SEMS screws for wiring of the separate base
- Optional relay, isolator, and sounder bases
- Plugs into separate base for ease of installation and maintenance

## DETECTOR SPACING AND APPLICATIONS

Honeywell recommends spacing detectors in compliance with NFPA 72. In low airflow applications with smooth ceiling, space detectors 30 feet (9m). For specific information regarding detector spacing, placement, and special applications refer to NFPA 72. System Smoke Detector Application Guide, document A05-1003, is available at [systemsensor.com](http://systemsensor.com)

## INSTALLATION

The IDP-PHOTO-W Series plug-in detectors use a separate base to simplify installation, service, and maintenance. Installation instructions are shipped with each detector.

Mount base (all base types) on an electrical backbox which is at least 1.5" (3.81 cm) deep.

## NOTE:

- Because of the inherent supervision provided by the SLC loop, end-of-line resistors are not required. Wiring "T-taps" or branches are permitted for Style 4 (Class "B") wiring.
- When using relay or sounder bases, consult the installation sheet for device limitations between isolator modules and isolator bases.

## ORDERING INFORMATION

**NOTE:** Detectors must be mounted to one of the Intelligent Bases listed below

**IDP-PHOTO-W:** White, low-profile intelligent photoelectric sensor.

**IDP-PHOTO-IV:** Ivory, low-profile intelligent photoelectric sensor.

**IDP-PHOTO-T-W:** White, same as the IDP-PHOTO-W, but includes a built-in 135°F (57°C) fixed-temperature thermal device.

**IDP-PHOTO-T-IV:** Same as IDP-PHOTO-T but in Ivory.

**IDP-PHOTO-R-W:** White, low-profile intelligent photoelectric sensor, remote test capable. For use with DNR/DNRW..

**IDP-PHOTO-R-IV:** Ivory, low-profile intelligent photoelectric sensor, remote test capable. For use with DNR/DNRW.

## INTELLIGENT BASES

**B300-6:** White, standard flanged low-profile mounting base.

**B300-6-BP:** Bulk pack of B300-6, package contains 10.

**B300-6-IV:** Ivory, standard flanged low-profile mounting base.

**B501-WHITE:** White, standard European flangeless mounting base. UL listed.

**B501-BL:** Black, standard European flangeless mounting base. UL listed.

**B501-IV:** Ivory, standard European flangeless mounting base. UL listed.

**B200S-WH:** White, Intelligent, programmable sounder base.

**B200S-IV:** Ivory, Intelligent, programmable sounder base.

**B200SR-WH:** White, Intelligent sounder base for retrofit applications.

**B200SR-IV:** Ivory, Intelligent sounder base for retrofit applications.

**B200S-LF-WH:** White, Low Frequency Intelligent, programmable sounder base.

**B200S-LF-IV:** Ivory, Low Frequency Intelligent, programmable sounder base.

**B200SR-LF:** White, Low Frequency Intelligent sounder base for retrofit applications.

**B200SR-LF-IV:** Ivory, Low Frequency Intelligent sounder base for retrofit applications.

**B224RB-WH:** White, plug-in System Sensor relay base.

**B224RB-IV:** Ivory, plug-in System Sensor relay base.

**B224BI-WH:** White, plug-in System Sensor isolator detector base.

**B224BI-IV:** Ivory, plug-in System Sensor isolator detector base.

## ACCESSORIES

**TR300:** White, replacement flange for B210LP and B300-6 bases.

**TR300-IV:** Ivory, replacement flange for B210LP and B300-6 bases.

**RA100Z:** Remote LED annunciator. 3 – 32 VDC. Mounts to a U.S. single-gang electrical box. For use with B501 and B300(A)-6 bases only.

**M02-04-00:** Test magnet.

**M02-09-00:** Test magnet with telescoping handle.

**CK300:** White, detector color kit. Pack of 10.

**CK300-IV:** Ivory, detector color kit. Pack of 10.

**CK300-BL:** Black, detector color kit. Pack of 10.

# Farenhyt IDP-PHOTO-W Series Technical Specifications

## PHYSICAL

**Height:** 2.0" (51mm) installed in B300-6 base

**Diameter:** 6.2" (156mm) installed in B300-6 base  
4.1" (104 mm) installed in B501 base

**Weight:** 3.4 oz (95 g)

## ENVIRONMENTAL

**Operating Temperature range:**

**Photo:** 32°F to 122°F (0°C to 50°C)

**Photo with Thermal:** 32°F to 100°F (0°C to 38°C)

**Thermal Ratings:** Fixed Temperature Set point:  
135°F (57°C)

**Sensitivity:** UL Applications: 0.5% to 4.0% per foot obscuration.

## ELECTRICAL RATINGS

**Voltage Range:** 15 to 32VDC peak

**Operating Current @ 24VDC:** 200µA (one communication every 5 seconds with green LED blink on communication)

**Maximum Current:** 4.5mA @ 24VDC (one communication every 5 seconds with amber LED solid on).

## COMPATIBILITY

**The IDP-PHOTO-W series detectors are compatible with the following Farenhyt Series**

### FACPs:

- IFP-2100 / IFP-2100ECS / RFP-2100
- IFP-2000 / IFP-2000ECS / RPS-2000
- IFP-1000 / IFP-1000ECS
- IFP-300 / IFP-300ECS
- IFP-100 / IFP-100ECS
- IFP-75
- IFP-50

## AGENCY LISTINGS AND APPROVALS

For exact certification listings for each model, please reference the respective agency Web site.

**UL listed:** S6173

**FM approved**

**CSFM:** 7272-0559:0512

For a complete listing of all compliance approvals and certifications, please visit [www.farenhyt.com](http://www.farenhyt.com).

Microsoft, Windows, and the Windows Logo are registered trademarks or trademarks of Microsoft Corporation.

Honeywell® and System Sensor® are registered trademark of and Farenhyt™ is a trademark of Honeywell International, Inc.

This document is not intended to be used for installation purposes. We try to keep our product information up-to date and accurate. We cannot cover all specific applications or anticipate all requirements. All specifications are subject to change without notice.

For Technical Support, Please call 800-446-6444.

## For more information

Learn more about Honeywell's Farenhyt Series and other products available by visiting [www.farenhyt.com](http://www.farenhyt.com)

## Honeywell Farenhyt

12 Clintonville Road  
Northford, CT 06472  
800-328-0103



# B300-6 and B300-6-IV 6" Plug-in Detector Bases

3825 Ohio Avenue, St. Charles, Illinois 60174  
1-800-SENSOR2, FAX: 630-377-6495  
www.systemsensor.com

**SPECIFICATIONS**

Base Diameter:	6.1 inches (155 mm)
Base Height:	0.76 inches (19 mm)
Operating Temperature:	Refer to applicable sensor Operating Temperature Range using the Base/Sensor Cross Reference Chart at systemsensor.com.
<b>Electrical Ratings:</b>	
Operating Voltage:	15 to 32 VDC
Standby Current:	170 $\mu$ A
Listings:	UL268

**BEFORE INSTALLING**

Please read the *System Smoke Detectors Application Guide*, which provides detailed information on detector spacing, placement, zoning, wiring, and special applications. Copies of this application guide are available from System Sensor. NFPA 72 guidelines should be observed.

**NOTICE:** This manual should be left with the owner/user of this equipment.

**IMPORTANT:** The detector used with this base must be tested and maintained regularly following NFPA 72 requirements. The detector should be cleaned at least once a year.

**GENERAL DESCRIPTION**

The B300-6 and B300-6-IV are plug-in detector bases intended for use in an intelligent system, with screw terminals provided for power (+ and -), and remote annunciator connections. Communication takes place over the power lines (+ and -).

**BASE TERMINALS**

**NO. FUNCTION**

- 1 Power (-), Remote Annunciator (-)
- 2 Power (+)
- 3 Remote Annunciator (+)

**FIGURE 1. TERMINAL LAYOUT**

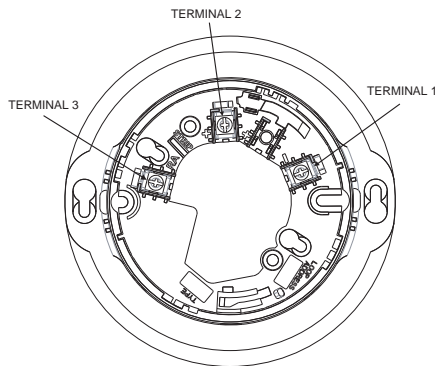

C2252-00

**MOUNTING**

This detector base mounts directly to 4-inch square (with and without plaster rings), 4-inch octagon, 3 1/2-inch octagon, and single gang junction boxes. To mount, remove the decorative ring by turning it in either direction to unhook the snaps, then separate the ring from the base. Install the base on the box using the screws supplied with the junction box and the appropriate mounting slots in the base.

Place the decorative trim ring on the base and rotate it in either direction until it snaps into place. (See Figure 2.)

**FIGURE 2. MOUNTING DETECTOR TO BOX**

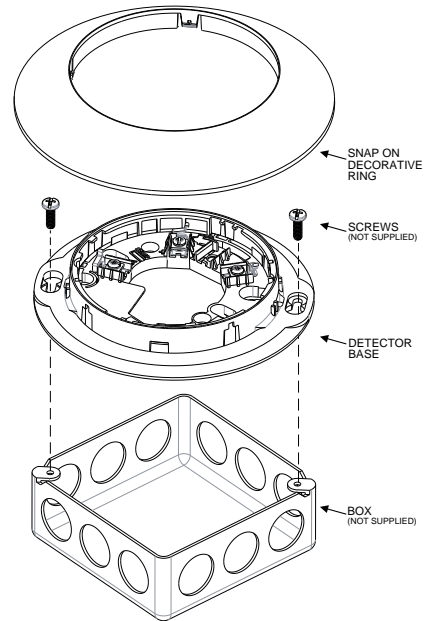

C2253-00

**INSTALLATION AND WIRING GUIDELINES (SEE FIGURE 3)**

All wiring must be installed in compliance with all applicable local codes and any special requirements of the authority having jurisdiction. Proper wire gauges should be used. The conductors used to connect smoke detectors to control panels and accessory devices should be color-coded to reduce the likelihood of wiring errors. Improper connections can prevent a system from responding properly in the event of a fire.

For signal wiring (the wiring between interconnected detectors), it is recommended that the wire be no smaller than 18 AWG (0.823 mm<sup>2</sup>). Wire sizes up to 12 AWG (3.31 mm<sup>2</sup>) may be used with the base.

Make electrical connections by stripping about 3/8 inch (10 mm) of insulation from the end of the wire (use strip gauge molded in base). Then slide the wire under the clamping plate and tighten the clamping plate screw. Do not loop the wire under the clamping plate. (See Figure 4.)

Check the zone wiring of all bases in the system before installing the detectors. This includes checking the wiring for continuity, correct polarity, ground fault testing and performing a dielectric test.

The base includes an area for recording the zone, address, and type of detector being installed. This information is useful for setting the detector head address and for verification of the detector type required for that location.

Once all detector bases have been wired and mounted, and the loop wiring has been checked, the detector heads may be installed in the bases.

**TAMPER-RESIST FEATURE**

NOTE: Do not use the tamper-resist feature if a removal tool will be used.

The detector base includes a tamper-resist feature that prevents removal of the detector without using a small screwdriver or similar tool.

To activate this feature, use needle-nose pliers to break the tab on the detector base as shown in Figure 5A. Then, install the detector.

To remove the detector from the base once the tamper-resist feature has been activated, remove the decorative ring by rotating it in either direction and pulling it away from the base. Then, insert a small screwdriver into the notch, as indicated in Figure 5B, and press the plastic lever toward the mounting surface before rotating the detector counterclockwise for removal.

The tamper-resist feature can be defeated by breaking and removing the plastic lever from the base. However, this prevents the feature from being used again.

**REMOTE ANNUNCIATOR (RA100Z)**

Connect the remote annunciator between terminals 1 and 3 using the spade lug terminal included. The spade lug terminal is connected to the base terminal as shown in Figure 6.

It is not acceptable to have three stripped wires under the same wiring terminal unless they are separated by a washer or equivalent means. The spade lug supplied with the model RA100Z is considered an equivalent means. See Figure 3 for proper installation.

**FIGURE 3. TYPICAL WIRING DIAGRAM FOR 2-WIRE LOOP**

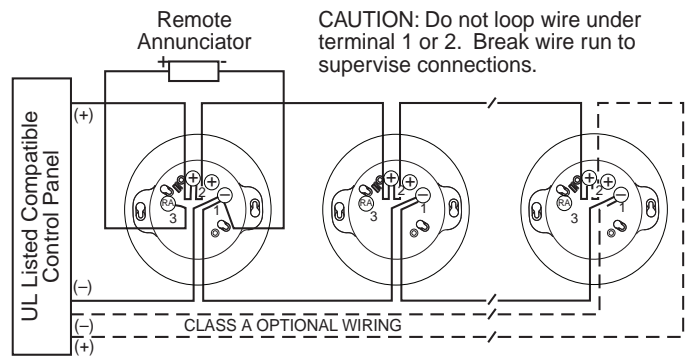

C0129-10

**FIGURE 4. TERMINAL WIRE INSTALLATION**

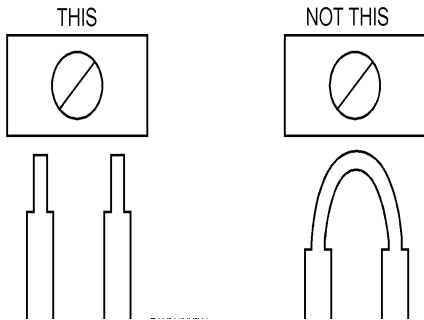

C0473-00

**FIGURE 5A. ACTIVATE TAMPER-RESIST FEATURE**

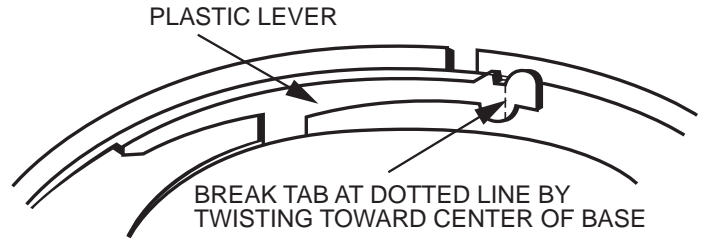

C0130-00

**FIGURE 5B. DETECTOR REMOVAL**

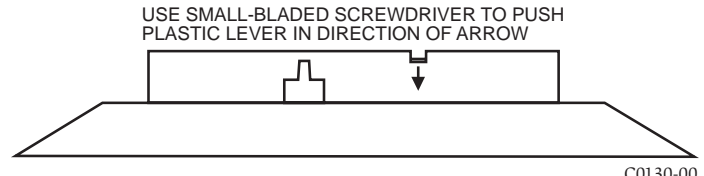

C0130-00

**FIGURE 6. CONNECTION TO REMOTE ANNUNCIATOR TERMINAL**

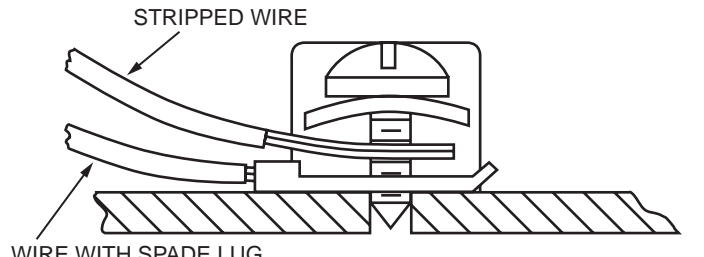

C0116-00

**Please refer to insert for the Limitations of Fire Alarm Systems**

**THREE-YEAR LIMITED WARRANTY**

System Sensor warrants its enclosed smoke detector base to be free from defects in materials and workmanship under normal use and service for a period of three years from date of manufacture. System Sensor makes no other express warranty for this smoke detector base. No agent, representative, dealer, or employee of the Company has the authority to increase or alter the obligations or limitations of this Warranty. The Company's obligation of this Warranty shall be limited to the repair or replacement of any part of the smoke detector base which is found to be defective in materials or workmanship under normal use and service during the three year period commencing with the date of manufacture. After phoning System Sensor's toll free number 800-SENSOR2 (736-7672) for a Return Authorization number, send defective units postage prepaid to: Honeywell,

12220 Rojas Drive, Suite 700, El Paso TX 79936 USA. Please include a note describing the malfunction and suspected cause of failure. The Company shall not be obligated to repair or replace units which are found to be defective because of damage, unreasonable use, modifications, or alterations occurring after the date of manufacture. In no case shall the Company be liable for any consequential or incidental damages for breach of this or any other Warranty, expressed or implied whatsoever, even if the loss or damage is caused by the Company's negligence or fault. Some states do not allow the exclusion or limitation of incidental or consequential damages, so the above limitation or exclusion may not apply to you. This Warranty gives you specific legal rights, and you may also have other rights which vary from state to state.

System Sensor® is a registered trademark of Honeywell International, Inc.



## Indoor Selectable-Output Strobes and Horn Strobes for Ceiling Applications

*System Sensor L-Series audible visible notification products are rich with features guaranteed to cut installation times and maximize profits with lower current draw and modern aesthetics.*



### Features

- Plug-in design with minimal intrusion into the back box
- Tamper-resistant construction
- Automatic selection of 12- or 24-volt operation at 15 and 30 candela
- Field-selectable candela settings on ceiling units: 15, 30, 75, 95, 115, 150, and 177
- Horn rated at 88+ dBA at 16 volts
- Rotary switch for horn tone and two volume selections
- Universal mounting plate for ceiling units
- Mounting plate shorting spring feature checks wiring continuity before device installation
- Electrically Compatible with legacy SpectrAlert and SpectrAlert Advance devices
- Compatible with MDL3 sync module
- Listed for ceiling mounting only

**The System Sensor L-Series** offers the most versatile and easy-to-use line of horns, strobes, and horn strobes in the industry with lower current draws and modern aesthetics. With white and red plastic housings, wall and ceiling mounting options, System Sensor L-Series can meet virtually any application requirement.

The entire L-Series product line of ceiling-mount strobes and horn strobes include a variety of features that increase their application versatility while simplifying installation. All devices feature a plug-in design with minimal intrusion into the back box, making installations fast and foolproof while virtually eliminating costly and time-consuming ground faults.

To further simplify installation, the L-Series utilizes a universal mounting plate so installers can mount them to a wide array of back boxes. With an onboard shorting spring, installers can test wiring continuity before the device is installed.

Installers can also easily adapt devices to suit a wide range of application requirements using field-selectable candela settings, automatic selection of 12- or 24-volt operation, and a rotary switch for horn tones with two volume selections.

### Agency Listings





# L-Series Specifications

## Architect/Engineer Specifications

### General

L-Series ceiling-mount strobes and horn strobes shall mount to a standard 4 × 4 × 1½-inch back box, 4-inch octagon back box, or double-gang back box. Two-wire products shall also mount to a single-gang 2 × 4 × 17/8-inch back box. A universal mounting plate shall be used for mounting ceiling and wall products. The notification appliance circuit wiring shall terminate at the universal mounting plate. Also, L-Series products, when used with the Sync•Circuit™ Module accessory, shall be powered from a non-coded notification appliance circuit output and shall operate on a nominal 12 or 24 volts. When used with the Sync•Circuit Module, 12-volt-rated notification appliance circuit outputs shall operate between 8.5 and 17.5 volts; 24-volt-rated notification appliance circuit outputs shall operate between 16.5 and 33 volts. Indoor L-Series products shall operate between 32 and 120 degrees Fahrenheit from a regulated DC or full-wave rectified unfiltered power supply. Ceiling strobes and horn strobes shall have field-selectable candela settings including 15, 30, 75, 95, 115, 150, and 177.

### Strobe

The strobe shall be a System Sensor L-Series Model \_\_\_\_\_ listed to UL 1971 and shall be approved for fire protective service. The strobe shall be wired as a primary-signaling notification appliance and comply with the Americans with Disabilities Act requirements for visible signaling appliances, flashing at 1 Hz over the strobe's entire operating voltage range. The strobe light shall consist of a xenon flash tube and associated lens/reflector system.

### Horn Strobe Combination

The horn strobe shall be a System Sensor L-Series Model \_\_\_\_\_ listed to UL 1971 and UL 464 and shall be approved for fire protective service. The horn strobe shall be wired as a primary-signaling notification appliance and comply with the Americans with Disabilities Act requirements for visible signaling appliances, flashing at 1 Hz over the strobe's entire operating voltage range. The strobe light shall consist of a xenon flash tube and associated lens/reflector system. The horn shall have two audibility options and an option to switch between a temporal three pattern and a non-temporal (continuous) pattern. These options are set by a multiple position switch. The horn on horn strobe models shall operate on a coded or non-coded power supply.

### Synchronization Module

The module shall be a System Sensor Sync•Circuit model MDL3 listed to UL 464 and shall be approved for fire protective service. The module shall synchronize L-Series strobes at 1 Hz and horns at temporal three. Also, while operating the strobes, the module shall silence the horns on horn strobe models over a single pair of wires. The module shall mount to a 4 11/16 × 4 11/16 × 2 1/8-inch back box. The module shall also control two Style Y (class B) circuits or one Style Z (class A) circuit. The module shall synchronize multiple zones. Daisy chaining two or more synchronization modules together will synchronize all the zones they control. The module shall not operate on a coded power supply.

## Physical/Electrical Specifications

<b>Standard Operating Temperature</b>	32°F to 120°F (0°C to 49°C)
<b>Humidity Range</b>	10 to 93% non-condensing
<b>Strobe Flash Rate</b>	1 flash per second
<b>Nominal Voltage</b>	Regulated 12 VDC or regulated 24 DC/FWR <sup>1</sup>
<b>Operating Voltage Range<sup>2</sup></b>	8 to 17.5 V (12 V nominal) or 16 to 33 V (24 V nominal)
<b>Operating Voltage Range (MDL3)</b>	8.5 to 17.5V (12 V nominal) or 16.5 to 33 V (24V nominal)
<b>Input Terminal Wire Gauge</b>	12 to 18 AWG
<b>Ceiling-Mount Dimensions (Including lens)</b>	6.8" diameter × 2.5" high (173 mm diameter × 64 mm high)
<b>Ceiling-Mount Surface Mount Back Box Skirt Dimensions (SBBCL, SBBCLW)</b>	6.9" diameter × 3.4" high (175 mm diameter × 86 mm high)

### Notes:

1. Full Wave Rectified (FWR) voltage is a non-regulated, time-varying power source that is used on some power supply and panel outputs.
2. P, S, PC, and SC products will operate at 12 V nominal only for 15 and 30 cd.

## UL Current Draw Data

UL Max. Strobe Current Draw (mA RMS)				
Candela Range	Candela	8-17.5 Volts		
		DC	16-33 Volts DC	FWR
Candela Range	15	87	41	60
	30	153	63	86
	75	N/A	111	142
	95	N/A	134	164
	115	N/A	158	191
	150	N/A	189	228
	177	N/A	226	264

UL Max. Horn Current Draw (mA RMS)				
Sound Pattern	dB	8-17.5 Volts		
		DC	16-33 Volts DC	FWR
Temporal	High	39	44	54
Temporal	Low	28	32	54
Non-Temporal	High	43	47	54
Non-Temporal	Low	29	32	54
3.1 KHz Temporal	High	39	41	54
3.1 KHz Temporal	Low	29	32	54
3.1 KHz Non-Temporal	High	42	43	54
3.1 KHz Non-Temporal	Low	28	29	54
Coded	High	43	47	54
3.1 KHz Coded	High	42	43	54

UL Max. Current Draw (mA RMS), Ceiling Horn Strobe, Candela Rangs (15-177 cd)										
DC Input	8-17.5 Volts		16-33 Volts							
	15cd	30cd	15cd	30cd	75cd	95cd	115cd	150cd	177cd	
Temporal High	103	167	71	90	143	165	187	217	254	
Temporal Low	96	165	54	71	137	161	185	211	249	
Non-Temporal High	106	173	71	90	141	165	187	230	273	
Non-Temporal Low	95	166	54	71	124	161	170	216	258	
3.1K Temporal High	111	164	69	94	147	163	184	229	257	
3.1K Temporal Low	103	163	54	88	143	155	185	212	252	
3.1K Non-Temporal High	111	172	69	94	144	164	202	229	271	
3.1K Non-Temporal Low	103	169	54	88	131	155	187	217	259	

FWR Input	16-33 Volts						
	15cd	30cd	75cd	95cd	115cd	150cd	177cd
Temporal High	107	135	179	198	223	254	286
Temporal Low	78	101	151	172	199	229	262
Non-Temporal High	107	135	179	198	223	254	286
Non-Temporal Low	78	101	151	172	199	229	262
3.1K Temporal High	108	135	179	200	225	255	289
3.1K Temporal Low	79	101	150	171	196	229	260
3.1K Non-Temporal High	108	135	179	200	225	255	289
3.1K Non-Temporal Low	79	101	150	171	196	229	260

## Horn Strobe Tones and Sound Output Data

Horn Strobe Output (dBA)					
Switch Position	Sound Pattern	dB	8-17.5 Volts	16-33 Volts	FWR
			DC	DC	
1	Temporal	High	84	89	89
2	Temporal	Low	75	83	83
3	Non-Temporal	High	85	90	90
4	Non-Temporal	Low	76	84	84
5	3.1 KHz Temporal	High	83	88	88
6	3.1 KHz Temporal	Low	76	82	82
7	3.1 KHz Non-Temporal	High	84	89	89
8	3.1 KHz Non-Temporal	Low	77	83	83



## L-Series Dimensions

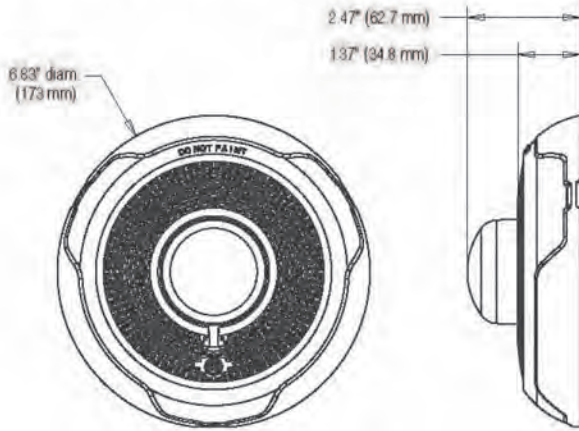

**Ceiling-Mount Horn Strobes**

A0545-00

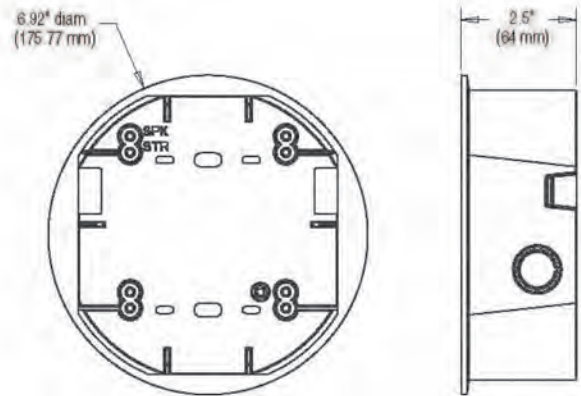

**Ceiling Surface Mount Back Box**

A0546-00

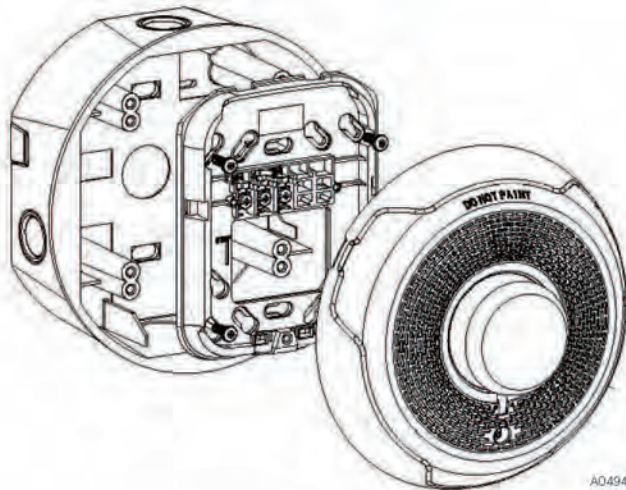

**2-Wire Ceiling Mount Horn Strobes  
with Ceiling Surface Mount Back Box**

A0494-01

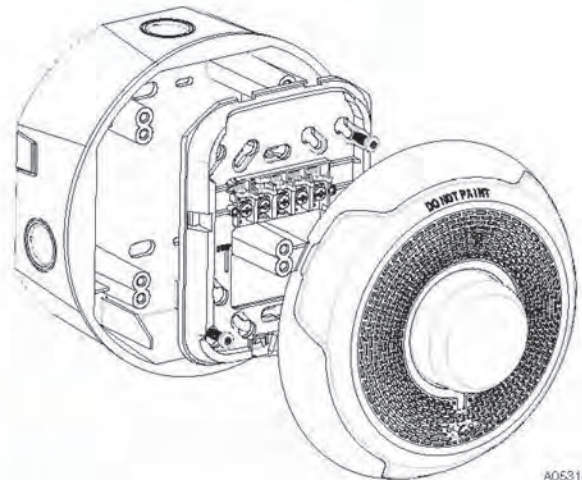

**4-Wire Ceiling Mount Horn Strobes  
with Ceiling Surface Mount Back Box**

A0531-01

## L-Series Ordering Information

Model	Description
<b>Ceiling Horn Strobes</b>	
PC2RL	2-Wire, Horn Strobe, Red
PC2WL	2-Wire, Horn Strobe, White
PC4RL	4-Wire, Horn Strobe, Red
PC4WL	4-Wire, Horn Strobe, White

Model	Description
<b>Ceiling Strobes</b>	
SCRL	Strobe, Red
SCWL	Strobe, White
SCWL-CLR-ALERT	Strobe, White, ALERT
<b>Accessories</b>	
TRC-2	Universal Ceiling Trim Ring Red
TRC-2W	Universal Ceiling Trim Ring White
SBBCRL	Ceiling Surface Mount Back Box, Red
SBBCWL	Ceiling Surface Mount Back Box, White

For a ceiling-listed horn-only device, see AVDS865 "Indoor Selectable-Output Horns, Strobes, and Horn Strobes for Wall Applications".



3825 Ohio Avenue • St. Charles, IL 60174  
Phone: 800-SENSOR2 • Fax: 630-377-6495

©2017 System Sensor.  
Product specifications subject to change without notice. Visit [systemsensor.com](http://systemsensor.com)  
for current product information, including the latest version of this data sheet.  
AVDS868-02 • 12/01/2017