



Froula Alarm Systems, Inc.

861 Industry Drive ♦ Tukwila WA 98188-3411

Phone: 206-575-1962 ♦ Fax: 206-575-8168

October 25, 2023

Fire Alarm System

Submittals

For

Multicare GSMOB

Suite 4400

Tenant Improvement

1450 – 5th Street SE

Puyallup, Washington 98372

HOWARD WILLIAMSON, SET

NICET #82289

FIRE ALARM SYSTEMS

LEVEL IV

Howard Williamson



Froula Alarm Systems, Inc.

861 Industry Drive ♦ Tukwila WA 98188-3411

Phone: 206-575-1962 ♦ Fax: 206-575-8168

Multicare GSMOB Suite 4400 Tenant Improvement

October 25, 2023

Table of Contents

Fire Alarm System

<u>Manufacturer</u>	<u>Model No.</u>	<u>Description</u>
Farenhyt	IFP-1000	Addressable Fire Alarm Control Panel - EXISTING
Potter	PSN-106	Booster Power Supply
Farenhyt	IDP-Photo	Addressable Smoke Detector
Farenhyt	B300-6	Detector Base
System Sensor	SWL	Multi-Candela Wall Mount Strobe
System Sensor	P2WL	Multi-Candela Wall Mount Horn/Strobe - EXISTING
System Sensor	SCWL	Multi-Candela Ceiling Mount Strobe
System Sensor	SPSWL	Multi-Candela Wall Mount Speaker/Strobe
System Sensor	SPSCWL	Multi-Candela Ceiling Mount Speaker/Strobe
Interstate	BSL1075	12V 7.2AH Battery
Interstate	BSL1105	12V 12AH Battery
Coleman	81802	18-2 FPLP Wire
Coleman	81402	14-2 FPLP Wire

Farenhyt



Addressable Fire Control Panel

Analog/Addressable Fire Alarm Control System

IFP-1000/IFP-1000HV

The IFP-1000 and IFP-1000HV are intelligent analog/addressable fire alarm control panels (FACPs). The basic IFP-1000 system has one signal line circuit (SLC) loop that supports up to seven 5815XL signal line circuit expanders. The IFP-1000HV offers the same functionality and features as the IFP-1000 but is configured for 240 VAC operation.

IFP-1000/HV has six on-board Flexput™ circuits that can be configured for auxiliary power, notification outputs, or for conventional smoke detector inputs (Class A or Class B). The FACP also has a built-in, dual-line digital fire communicator, Form C trouble relay, and two programmable Form C relays. The firmware has powerful features such as detector sensitivity, day/night thresholds, drift compensation, pre-trouble maintenance alert, and calibration trouble alert.

IFP-1000/HV supports a variety of devices, including RA-1000 remote annunciator, 5824 serial/parallel printer interface module (for printing system reports), RPS-1000 intelligent power module, and Hochiki or Intelligent Device Protocol (IDP) devices.

Features

- Built-in support for up to 127 Hochiki devices or 99 IDP detectors and 99 IDP modules, expandable to 1016 Hochiki devices or 792 IDP detectors and 792 IDP modules
- Uses standard wire—no shielded or twisted pair required
- Built-in UL listed digital communicator for remote reporting of system activity and system programming
- Central station reporting by point or by zone
- Supports Class B (Style 4) and Class A (Style 6 or Style 7) configuration for SLC, and SBUS
- Distributed, intelligent power
- Sensor sensitivity settings, day/night sensitivity setting and automatic drift compensation
- Flexput™ I/O circuits configurable for auxiliary power, notification outputs, or conventional smoke detector inputs. Notification circuits can be configured as Class A (Style Z) or Class B (Style Y). 2- and 4-wire smoke detectors can be configured as Class A (Style D) or Class B (Style B)
- Built-in annunciator with a backlit 80-character LCD display
- RS-485 bus provides communication to system accessories
- Built-in RS-232 and USB interface for programming
- Upload or download programming, event history, or detector status onsite or from a remote location using a PC and 5650/5651 Silent Knight Software Suite (SKSS)
- Improvements in SKSS delivers five times faster upload/downloads
- Built-in Form C trouble relay rated at 2.5 amps at 27.4 VDC
- Two built-in Form C programmable relays rated at 2.5 amps at 27.4 VDC
- Individual addressable devices can be tested
- SLC device locator can locate a single or multiple devices on a SLC loop
- System automatically tests addressable devices

Agency Listings



MEA
429-92-E
VOL. IX



IFP-1000

- 13 preset notification cadence patterns (including ANSI 3.41) and four user programmable patterns
- Programmable to automatically display initial event first or display tally of system events
- Built-in synchronization for appliances from AMSECO, System Sensor®, Faraday, Gentex®, and Wheelock®
- Acknowledge function allows operator to keep track of event status
- Jumpstart® auto-programming
- Modular design
- Nonvolatile event history stores up to 1000 events
- 125 software zones and 250 output groups
- 6 amp power supply and maximum charging capacity of 35 amp hours (An additional cabinet enclosure is required for batteries in excess of 18 amp hours)
- Programmable date setting for Daylight Saving Time
- Plex-1 door option combines a dead front cabinet door with a clear window, limiting access to the panel while providing single button operation of the reset and silence functions

P/N 350093 Rev L

Copyright © 2013 Honeywell International Inc.

Installation

The IFP-1000/HV can be surface or flush mounted.

Compatibility

The IFP-1000/HV SLC supports multiple device types of the *same* protocol:

- IDP or Hochiki

You cannot mix Hochiki and IDP devices on a FACP. However, any combination of addressable devices of the same protocol can be used on the IFP-1000/HV.

Specifications

Physical

Flush Mount Dimensions: 14.5"W x 24.75"H x 3.9"D
(36.8 W x 62.9 H x 9.8 D cm)

Overall Dimensions: 16.2"W x 26.4"H x 4.2"D
(40.6 W x 67 H x 11.8 D cm)

Weight: 28 lbs. (12.8 kg)

Color: Red

Environmental

Operating Temperature: 32°F – 120°F (0°C – 49°C)

Humidity: 10% – 93% non-condensing

Electrical

IFP-1000 Primary AC: 120 VRMS @ 50/60 Hz, 2.7A

IFP-1000HV Primary AC: 240 VRMS @ 50/60 Hz, 1.4A

Total Accessory Load: 6A @ 27.4 VDC power-limited

Standby Current: 215 mA

Alarm Current: 385 mA

Battery Charging Capacity: 7 to 35 AH

Battery Size: 18 AH max. allowed in control panel cabinet. Larger capacity batteries can be housed in RBB accessory cabinet.

Flexput Circuits

Six circuits that can be programmed individually as:

Notification Circuits: 3A per circuit @ 27.4 VDC, power-limited

Auxiliary Power Circuits: 3A per circuit @ 27.4 VDC, power-limited

Initiation Circuit: 100 mA per circuit @ 27.4 VDC, power-limited

Indicator Lights

General Alarm (Red): Flashes when in alarm; solid when alarm silenced

Supervisory (Yellow): Flashes when a supervisory condition exists; solid when supervisory silenced

System Troubles (Yellow): Flashes when a trouble condition exists; solid when trouble silenced

System Silenced (Yellow): On when an alarm, trouble or supervisory condition has been silenced but not yet cleared

System Power (Green): Flashes for AC failure; solid when power systems are normal

Telephone

Requirements: FCC Part 15 & Part 68 approved

Jack: RJ31X (two required)

Approvals

NFPA 13, NFPA 15, NFPA 16, NFPA 70, & NFPA 72: Central Station; Remote Signalling; Local Protective Signalling Systems; Auxiliary Protected Premises Unit; & Water Deluge Releasing Service. Suitable for automatic, manual, waterflow, sprinkler supervisory (DACT non-coded) signalling services.

Other Approvals: UL Listed; CSFM 7170-0559: 135; MEA 429-92-E Vol. IX; FM Approved; OSHPD (CA) OSP-0065-10

Approved Releasing Solenoids

Manufacturer	Part Number	Rating	Current	Freq
Asco	T8210A107	24 VDC	3 A max	0 Hz
Asco	8210G207	24 VDC	3 A max	0 Hz

Ordering Information

IFP-1000	Intelligent Fire Alarm Control Panel.
IFP-1000HV	Intelligent Fire Alarm Control Panel. High voltage (240 VAC).

SBUS Accessories

RA-100	Remote Annunciator. Similar in operation and appearance to FACP annunciator. Gray.
RA-100R	Remote Annunciator. Similar in appearance and operation to FACP annunciator. Red.
RA-1000	Remote Annunciator. Four line LCD annunciator with 20 characters per line.
5815XL	Signal Line Circuit (SLC) Expander.
RPS-1000	Intelligent Power Module.
5496	Intelligent Power Module.
5824	Serial/Parallel Printer Interface Module.
5880	LED I/O Module.
5865-3 & 5865-4	LED Fire Annunciators.
5883	Relay Interface Board.

Hochiki and IDP Devices

See the specification sheets listed below for a complete listing of the Hochiki and IDP devices.

350360	Hochiki Devices Specification Sheet
350361	Intelligent Device Protocol Devices Specification Sheet

Miscellaneous Accessories

5650/5651	Silent Knight Software Suite. Provides programming, upload/download, and event reporting.
5670	Silent Knight Software Suite. Provides facility monitoring.
Plex-1	Door Accessory. Dead front cabinet door with clear window to limit access to panel.
RBB	Remote Battery Box Accessory Cabinet. Use if backup batteries are too large to fit into FACP cabinet. Dimensions: 16" W x 10" H x 6" D (406 mm W x 254 mm H x 152 mm D).
SK-SCK	Seismic Compliance Kit



**SILENT
KNIGHT**

by Honeywell

This document is not intended to be used for installation purposes. We try to keep our product information up-to-date and accurate. We cannot cover all specific applications or anticipate all requirements. All specifications are subject to change without notice. For more information, contact Silent Knight 12 Clintonville Road, Northford, CT 06472-1610 Phone: (800) 328-0103, Fax: (203) 484-7118. www.farenhyt.com



Made in the U.S.A.

Features

- PSN-64 has 6 amps regulated with 4 outputs
- PSN-106 has 10 amps regulated with 6 outputs
- May be configured as up to three class “A” Style “Z” notification circuits
- Two Trouble relays (5A at 30VDC) General System Trouble (programmable for AC delay) Low AC Trouble with optional delay settings
- Diagnostic LED’s Status LED’s for Active NAC and NAC Trouble conditions.
- Quadrasync feature synchronizes strobes from AMSECO, Gentex, Cooper-Wheelock and System Sensor.
- Configurable output circuits (DIP switch sets options for each circuit)
- Reference EOL allows 2K – 27K EOL value to be used
- Pass Thru mode allows the outputs to match the input signal from FACP



Description

The PSN series of notification power supplies offers reliable notification power with unprecedented versatility. The power supplies offer either 6 or 10 amps of continuous power through 4 or 6 outputs respectively. Each output is rated at 3 amps and it may be used continuously without any derating. The power supply operates on either 120 VAC or 220 VAC power input and has a regulated 24 VDC output. In addition, the power supply can charge up to 55 AH batteries and leads the industry in housing up to 18 AH batteries. The cabinet is constructed out of 18 gauge cold rolled steel and has a durable red powder coat finish. In addition, a key lock is provided for securing the door. Ample electrical knockouts are provided on the sides and the top, allowing the installer options for running wires and maintaining the correct separations.

The power supply offers an industry leading Quadrasync function that allows for multiple strobe circuits of different brands to be synchronized to flash at the same time. The power supply can have four different brands each connected to its own circuit and all the strobes flash together. Each output can independently be configured to provide one of four synchronizations or steady power. This provides unequivocal flexibility in new and retrofit installations. The power supply can be configured to synchronize AMSECO®, Gentex®, Wheelock® and System Sensor® strobe devices. Each output can be configured to the same sync protocol or set independently. In addition, the power supply has an input Pass Thru mode which allows the outputs to follow the input signal from a non-supported synchronization protocol. The power supply will recognize the type of input being supplied and pass this through to the outputs with

the same pattern. This input pass through can be selected on each output independently. The power supply contains simple dipswitch programming and LED indicators providing the installer the ability to correct any possible faults. A Trouble Memory is provided to allow an installer to review past troubles and make the necessary repairs. Each output has an LED to pinpoint the exact circuit where a trouble may have occurred. Relays are provided for monitoring the general system and AC failure. Each output can be independently configured for various applications and installations. Each output can be independently configured for Class A or Class B operation, constant power, ANSI Temporal Code 3, Single, Multiple or Combo Inputs or Door Holder Power.

Technical Specifications

Size (H x W x D)	16 1/8" W x 16 3/4" W x 3 1/2" D
Enclosure	Eighteen (18) gauge sheet steel with hinged, locked door
Power Input	120VAC @ 60Hz 220/240VAC @ 50Hz 5.1 Amps @ 120 VAC 2.5 Amps @ 240 VAC
Current	75mA Standby & Alarm (no external load)
Input Voltage Trigger	15mA @ 8 – 33 VDC
Terminals	18-12AWG
Temperature	32° F to 120°F (0°C to 49°C) with a maximum humidity of 93% non-condensing
NAC Output	3 Amp max per NAC, Regulated
Battery Charging	27.3 @ 1A, can support 7 – 55Ah batteries

PSN-106 Wiring Diagram

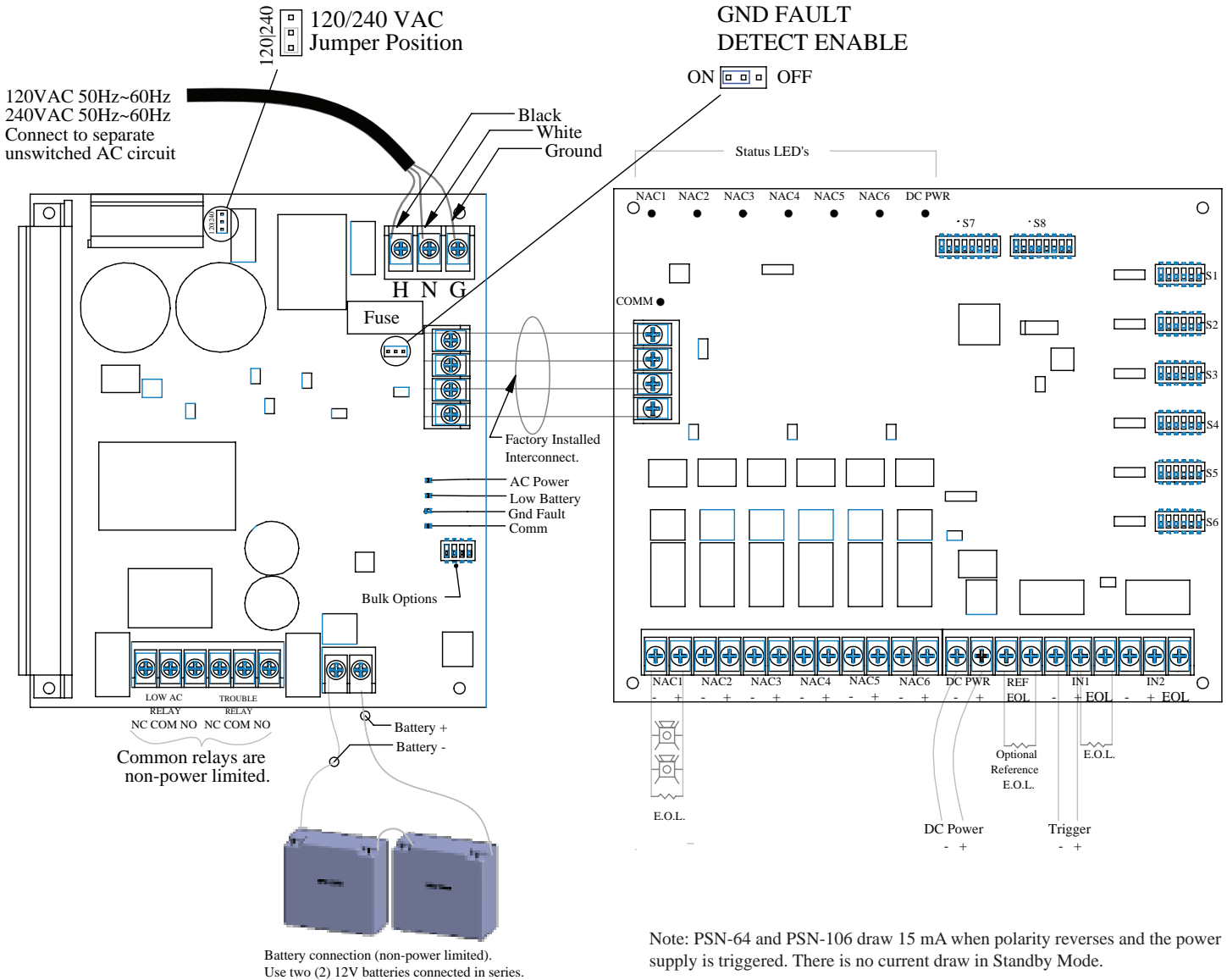

Ordering Information

Model	Description	Stock No.
PSN-106	10 A Power Supply, 6 NAC Circuits, Red Enclosure	3006437
PSN-106B	10 A Power Supply, 6 NAC Circuits, Black Enclosure	3006446
PSN-64	6 A Power Supply, 4 NAC Circuits, Red Enclosure	3006436

Engineering Specifications

The contractor shall supply and install the Potter PSN power supply. The power supply shall operate on either 120 or 240 VAC input. The panel shall be capable of continuous load power without any degradation to the main supply or the distribution board. The cabinet shall be capable of housing up to 18AH batteries and the panel shall be capable of charging up to 55 AH batteries in an external cabinet.

The panel shall have dip switches for simplistic configuration of the system and LEDs to provide visual indication to the installer of the status of the system. The dip switches shall allow for AC power delay selection, Class A/B operation per output, Door Holder Power options, constant auxiliary power, trigger input type, ANSI Code 3 Temporal Code, Pass Thru (input tracking), AMSECO® sync, Gentex® Sync, System Sensor® Sync or Wheelock® sync. The LEDs shall provide indication of communication between the power supply and distribution circuit assemblies. The LEDs shall have distinct flash patterns to provide further indication of the troubles present. The panel shall have selectable Trouble Memory to provide the installer an indication that a past trouble existed on a circuit for diagnostic purposes.

Each output of the power supply shall be capable of 3 amps of continuous power without degradation overtime. The power supply shall provide for multiple circuits of strobe appliances. The power supply shall synchronize the flashes of any of the above listed strobe appliances on a per circuit basis. Up to four different strobe circuits may be connected and all the strobes shall flash in unison as required by UL 864. In addition to this Quadrasync feature, the panel shall allow any of the four above mentioned sync patterns as an input and pass this signal through and synchronize the outputs to match the input flash pattern.

Features

- PSN-64 has 6 amps regulated with 4 outputs
- PSN-106 has 10 amps regulated with 6 outputs
- May be configured as up to three class “A” Style “Z” notification circuits
- Two Trouble relays (5A at 30VDC) General System Trouble (programmable for AC delay) Low AC Trouble with optional delay settings
- Diagnostic LED’s Status LED’s for Active NAC and NAC Trouble conditions.
- Quadrasync feature synchronizes strobes from AMSECO, Gentex, Cooper-Wheelock and System Sensor.
- Configurable output circuits (DIP switch sets options for each circuit)
- Reference EOL allows 2K – 27K EOL value to be used
- Pass Thru mode allows the outputs to match the input signal from FACP



Description

The PSN series of notification power supplies offers reliable notification power with unprecedented versatility. The power supplies offer either 6 or 10 amps of continuous power through 4 or 6 outputs respectively. Each output is rated at 3 amps and it may be used continuously without any derating. The power supply operates on either 120 VAC or 220 VAC power input and has a regulated 24 VDC output. In addition, the power supply can charge up to 55 AH batteries and leads the industry in housing up to 18 AH batteries. The cabinet is constructed out of 18 gauge cold rolled steel and has a durable red powder coat finish. In addition, a key lock is provided for securing the door. Ample electrical knockouts are provided on the sides and the top, allowing the installer options for running wires and maintaining the correct separations.

The power supply offers an industry leading Quadrasync function that allows for multiple strobe circuits of different brands to be synchronized to flash at the same time. The power supply can have four different brands each connected to its own circuit and all the strobes flash together. Each output can independently be configured to provide one of four synchronizations or steady power. This provides unequivocal flexibility in new and retrofit installations. The power supply can be configured to synchronize AMSECO®, Gentex®, Wheelock® and System Sensor® strobe devices. Each output can be configured to the same sync protocol or set independently. In addition, the power supply has an input Pass Thru mode which allows the outputs to follow the input signal from a non-supported synchronization protocol. The power supply will recognize the type of input being supplied and pass this through to the outputs with

the same pattern. This input pass through can be selected on each output independently. The power supply contains simple dipswitch programming and LED indicators providing the installer the ability to correct any possible faults. A Trouble Memory is provided to allow an installer to review past troubles and make the necessary repairs. Each output has an LED to pinpoint the exact circuit where a trouble may have occurred. Relays are provided for monitoring the general system and AC failure. Each output can be independently configured for various applications and installations. Each output can be independently configured for Class A or Class B operation, constant power, ANSI Temporal Code 3, Single, Multiple or Combo Inputs or Door Holder Power.

Technical Specifications

Size (H x W x D)	16 1/8" W x 16 3/4" W x 3 1/2" D
Enclosure	Eighteen (18) gauge sheet steel with hinged, locked door
Power Input	120VAC @ 60Hz 220/240VAC @ 50Hz 5.1 Amps @ 120 VAC 2.5 Amps @ 240 VAC
Current	75mA Standby & Alarm (no external load)
Input Voltage Trigger	15mA @ 8 – 33 VDC
Terminals	18-12AWG
Temperature	32° F to 120°F (0°C to 49°C) with a maximum humidity of 93% non-condensing
NAC Output	3 Amp max per NAC, Regulated
Battery Charging	27.3 @ 1A, can support 7 – 55Ah batteries

PSN-106 Wiring Diagram

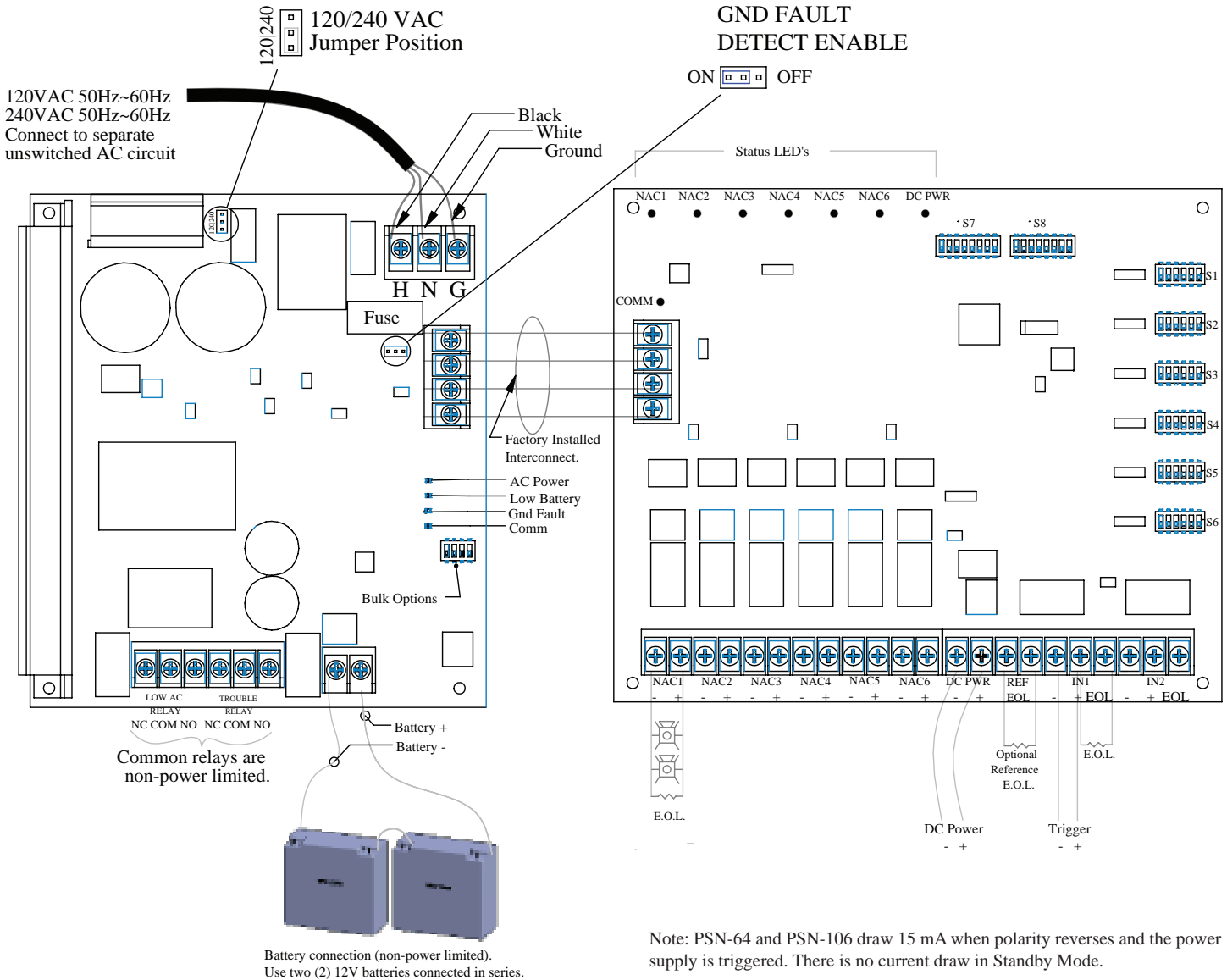

Note: PSN-64 and PSN-106 draw 15 mA when polarity reverses and the power supply is triggered. There is no current draw in Standby Mode.

Ordering Information

Model	Description	Stock No.
PSN-106	10 A Power Supply, 6 NAC Circuits, Red Enclosure	3006437
PSN-106B	10 A Power Supply, 6 NAC Circuits, Black Enclosure	3006446
PSN-64	6 A Power Supply, 4 NAC Circuits, Red Enclosure	3006436

Engineering Specifications

The contractor shall supply and install the Potter PSN power supply. The power supply shall operate on either 120 or 240 VAC input. The panel shall be capable of continuous load power without any degradation to the main supply or the distribution board. The cabinet shall be capable of housing up to 18AH batteries and the panel shall be capable of charging up to 55 AH batteries in an external cabinet.

The panel shall have dip switches for simplistic configuration of the system and LEDs to provide visual indication to the installer of the status of the system. The dip switches shall allow for AC power delay selection, Class A/B operation per output, Door Holder Power options, constant auxiliary power, trigger input type, ANSI Code 3 Temporal Code, Pass Thru (input tracking), AMSECO® sync, Gentex® Sync, System Sensor® Sync or Wheelock® sync. The LEDs shall provide indication of communication between the power supply and distribution circuit assemblies. The LEDs shall have distinct flash patterns to provide further indication of the troubles present. The panel shall have selectable Trouble Memory to provide the installer an indication that a past trouble existed on a circuit for diagnostic purposes.

Each output of the power supply shall be capable of 3 amps of continuous power without degradation overtime. The power supply shall provide for multiple circuits of strobe appliances. The power supply shall synchronize the flashes of any of the above listed strobe appliances on a per circuit basis. Up to four different strobe circuits may be connected and all the strobes shall flash in unison as required by UL 864. In addition to this Quadrasync feature, the panel shall allow any of the four above mentioned sync patterns as an input and pass this signal through and synchronize the outputs to match the input flash pattern.

IDP-PHOTO / IDP-PHOTO-T / IDP-PHOTOR

Intelligent Photoelectric Smoke Detector and Photoelectric Smoke Detector with Thermal

The IDP-PHOTO is a photoelectric smoke detector and the IDP-PHOTO-T is a photoelectric smoke detector with thermal. These plug in smoke detectors, with integral communication, provide features that surpass conventional detectors and are for use with the Honeywell Farenhyt Series fire alarm control panels (FACPs).

Detector sensitivity can be programmed from the FACP software. Sensitivity is continuously monitored and reported to the FACP. Point ID capability allows each detector's address to be set with rotary address switches, providing exact detector locations for selective maintenance when chamber contamination reaches unacceptable levels.

IDP-Photo and IDP-Photo-T have a unique optical sensing chamber that is engineered to sense smoke produced by a wide range of combustion sources. In the IDP-Photo-T, dual electronic thermistors add 135°F (57°C) thermal technology to maximize detection.

The IDP-PhotoR is a remote test capable detector for use with the DNR (W) duct smoke detectors. It is UL 268A listed when used with the DNR (W) duct smoke detector.

Installation

The IDP-Photo and IDP-Photo-T plug into a compatible IDP-series detector base. The IDP-PhotoR is a remote test capable detector for use with the DNR (W) duct smoke detector.



IDP-PHOTO (BASE NOT INCLUDED)

FEATURES & BENEFITS

- Sleek, low-profile design
- Superior EMI resistance for reliability
- Detector transmits signal to indicate maintenance is required
- Tamper-proof feature available on mounting bases
- MEA Listed 225-02-E Vol. V
- Reliable analog communications for trouble-free operation
- Simple field cleaning for code compliance
- Optional remote LED annunciator (System Sensor® PN RA100Z)
- Listed for use in duct applications
- Age resistant polymer housing
- Variety of mounting options to meet any application
- Plug-in mounting provides ease of installation
- Rotary address switches for fast installation
- Dual electronic thermistor design on the IDP-Photo-T
- Dual LED indicators for 360° visibility
- UL Listed
- FM Approved
- CSFM Listed

IDP-PHOTO, IDP-PHOTOR and IDP-PHOTO-T Technical Specifications

PHYSICAL

Height: 2.0" (5.08cm) less sensor

Diameter: 4.1" (10.4CM) installed in B501 base

ENVIRONMENTAL

Operating Temperature:

IDP-PHOTO: 32°F - 120 °F (0°C - 49°C)

IDP-PHOTO-T: 32°F - 100 °F (0°C - 38°C)

Humidity: 10 to 93% non-condensing)

ELECTRICAL RATINGS

Operating Voltage: 15 – 32VDC

SLC Standby and Alarm Current: 300 µA

OTHER RATINGS

IDP-PHOTO-T Thermal: Fixed temperature set point 135°F (57°C)

Velocity: 0 – 4000 fpm (0 – 20 m/sec) (suitable for installation in ducts)

IDP-PHOTO Insect Screen Hole Size: 0.016" (0.41 mm) nominal

ORDERING INFORMATION

IDP-PHOTO: Photoelectric Smoke Detector

IDP-PHOTO-T: Photoelectric Smoke Detector with Thermal (135°F)

IDP-PHOTOR: Photoelectric Smoke Detector, remote test capable, for use with DNR (W) duct smoke detector

ACCESSORIES

RA100Z: Remote LED Annunciator.

XR2B: Detector Removal Tool. A removal and replacement tool for IDP plug-in detectors. Includes the T55-127-000.

M02-04-01: Detector Test Magnet

M02-09-00: Test Magnet with Telescoping Handle

XP-4: Extension Pole for XR2B. Extends from 5 – 15 ft.

T55-127-000: Detector Removal Head.

BCK-200B: Black Detector Kit. For IDP-series detectors.

* Unless otherwise noted, specifications apply to IDP-Photo and IDP-Photo

COMPATIBILITY

The IDP-PHOTO, IDP-PHOTO-T and IDP-PHOTOR are compatible with the following IDP series detector bases:

- B210LP 6" Mounting Base
- B501 4" Mounting Base
- B224BI 6" Isolator Base
- B224RB 6" Relay Base
- B200SR 6" Sounder Base

The IDP-PHOTO, IDP-PHOTO-T and IDP-PHOTOR are compatible with the following Farenhyt Series FACP's:

- IFP-2100 / IFP-2100ECS / RFP-2100
- IFP-2000 / IFP-2000ECS / RPS-2000
- IFP-1000 / IFP-1000ECS
- IFP-300 / IFP-300ECS
- IFP-100 / IFP-100ECS
- IFP-75
- IFP-50

For a complete listing of all compliance approvals and certifications, please visit www.farenhyt.com.

Microsoft, Windows, and the Windows Logo are registered trademarks or trademarks of Microsoft Corporation.

Honeywell® is a registered trademark of and Farenhyt™ is a trademark of Honeywell International, Inc.

This document is not intended to be used for installation purposes. We try to keep our product information up-to date and accurate. We cannot cover all specific applications or anticipate all requirements. All specifications are subject to change without notice.

For Technical Support, Please call 800-446-6444.

For more information

Learn more about Honeywell's Farenhyt Series and other products available by visiting www.farenhyt.com

Honeywell Security & Fire

12 Clintonville Road
Northford, CT 06472
800-328-0103

B300-6 and B300-6-IV 6" Plug-in Detector Bases

3825 Ohio Avenue, St. Charles, Illinois 60174
1-800-SENSOR2, FAX: 630-377-6495
www.systemsensor.com

SPECIFICATIONS

Base Diameter:	6.1 inches (155 mm)
Base Height:	0.76 inches (19 mm)
Operating Temperature:	Refer to applicable sensor Operating Temperature Range using the Base/Sensor Cross Reference Chart at systemsensor.com.
Electrical Ratings:	
Operating Voltage:	15 to 32 VDC
Standby Current:	170 μ A
Listings:	UL268

BEFORE INSTALLING

Please read the *System Smoke Detectors Application Guide*, which provides detailed information on detector spacing, placement, zoning, wiring, and special applications. Copies of this application guide are available from System Sensor. NFPA 72 guidelines should be observed.

NOTICE: This manual should be left with the owner/user of this equipment.

IMPORTANT: The detector used with this base must be tested and maintained regularly following NFPA 72 requirements. The detector should be cleaned at least once a year.

GENERAL DESCRIPTION

The B300-6 and B300-6-IV are plug-in detector bases intended for use in an intelligent system, with screw terminals provided for power (+ and -), and remote annunciator connections. Communication takes place over the power lines (+ and -).

BASE TERMINALS

NO. FUNCTION

- 1 Power (-), Remote Annunciator (-)
- 2 Power (+)
- 3 Remote Annunciator (+)

FIGURE 1. TERMINAL LAYOUT

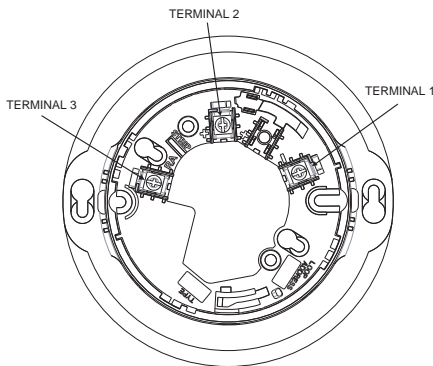

C2252-00

MOUNTING

This detector base mounts directly to 4-inch square (with and without plaster rings), 4-inch octagon, 3 1/2-inch octagon, and single gang junction boxes. To mount, remove the decorative ring by turning it in either direction to unhook the snaps, then separate the ring from the base. Install the base on the box using the screws supplied with the junction box and the appropriate mounting slots in the base.

Place the decorative trim ring on the base and rotate it in either direction until it snaps into place. (See Figure 2.)

FIGURE 2. MOUNTING DETECTOR TO BOX

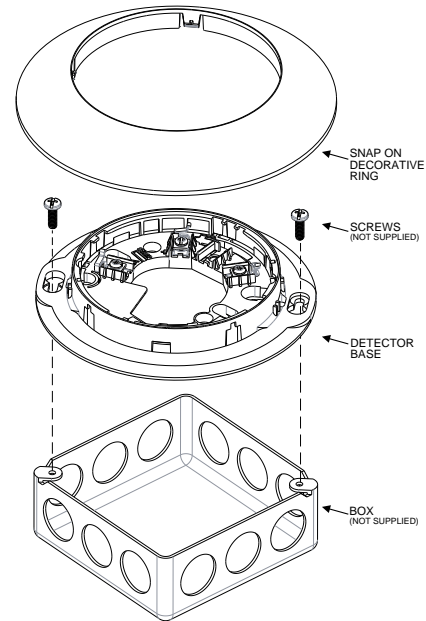

C2253-00

INSTALLATION AND WIRING GUIDELINES (SEE FIGURE 3)

All wiring must be installed in compliance with all applicable local codes and any special requirements of the authority having jurisdiction. Proper wire gauges should be used. The conductors used to connect smoke detectors to control panels and accessory devices should be color-coded to reduce the likelihood of wiring errors. Improper connections can prevent a system from responding properly in the event of a fire.

For signal wiring (the wiring between interconnected detectors), it is recommended that the wire be no smaller than 18 AWG (0.823 mm²). Wire sizes up to 12 AWG (3.31 mm²) may be used with the base.

Make electrical connections by stripping about 3/8 inch (10 mm) of insulation from the end of the wire (use strip gauge molded in base). Then slide the wire under the clamping plate and tighten the clamping plate screw. Do not loop the wire under the clamping plate. (See Figure 4.)

Check the zone wiring of all bases in the system before installing the detectors. This includes checking the wiring for continuity, correct polarity, ground fault testing and performing a dielectric test.

The base includes an area for recording the zone, address, and type of detector being installed. This information is useful for setting the detector head address and for verification of the detector type required for that location.

Once all detector bases have been wired and mounted, and the loop wiring has been checked, the detector heads may be installed in the bases.

TAMPER-RESIST FEATURE

NOTE: Do not use the tamper-resist feature if a removal tool will be used.

The detector base includes a tamper-resist feature that prevents removal of the detector without using a small screwdriver or similar tool.

To activate this feature, use needle-nose pliers to break the tab on the detector base as shown in Figure 5A. Then, install the detector.

To remove the detector from the base once the tamper-resist feature has been activated, remove the decorative ring by rotating it in either direction and pulling it away from the base. Then, insert a small screwdriver into the notch, as indicated in Figure 5B, and press the plastic lever toward the mounting surface before rotating the detector counterclockwise for removal.

The tamper-resist feature can be defeated by breaking and removing the plastic lever from the base. However, this prevents the feature from being used again.

REMOTE ANNUNCIATOR (RA100Z)

Connect the remote annunciator between terminals 1 and 3 using the spade lug terminal included. The spade lug terminal is connected to the base terminal as shown in Figure 6.

It is not acceptable to have three stripped wires under the same wiring terminal unless they are separated by a washer or equivalent means. The spade lug supplied with the model RA100Z is considered an equivalent means. See Figure 3 for proper installation.

FIGURE 3. TYPICAL WIRING DIAGRAM FOR 2-WIRE LOOP

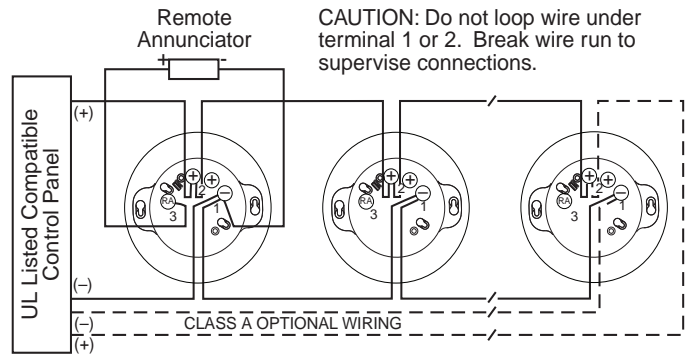

C0129-10

FIGURE 4. TERMINAL WIRE INSTALLATION

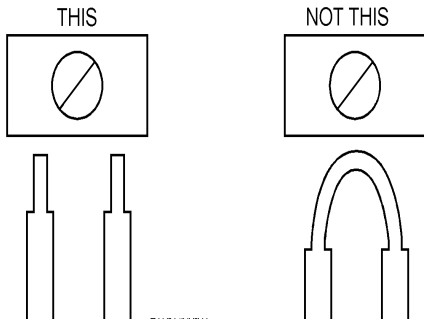

C0473-00

FIGURE 5A. ACTIVATE TAMPER-RESIST FEATURE

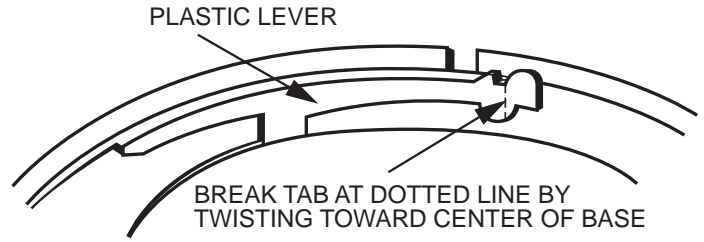

C0130-00

FIGURE 5B. DETECTOR REMOVAL

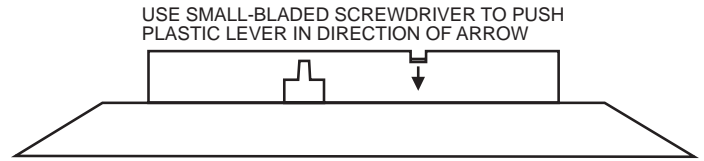

C0130-00

FIGURE 6. CONNECTION TO REMOTE ANNUNCIATOR TERMINAL

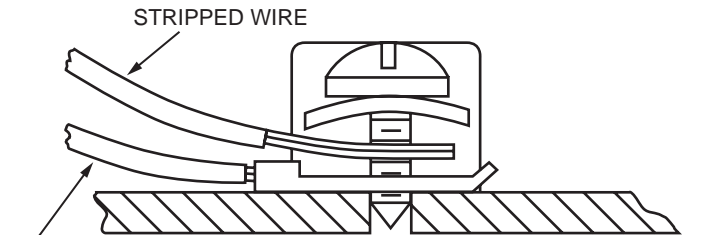

C0116-00

Please refer to insert for the Limitations of Fire Alarm Systems

THREE-YEAR LIMITED WARRANTY

System Sensor warrants its enclosed smoke detector base to be free from defects in materials and workmanship under normal use and service for a period of three years from date of manufacture. System Sensor makes no other express warranty for this smoke detector base. No agent, representative, dealer, or employee of the Company has the authority to increase or alter the obligations or limitations of this Warranty. The Company's obligation of this Warranty shall be limited to the repair or replacement of any part of the smoke detector base which is found to be defective in materials or workmanship under normal use and service during the three year period commencing with the date of manufacture. After phoning System Sensor's toll free number 800-SENSOR2 (736-7672) for a Return Authorization number, send defective units postage prepaid to: Honeywell,

12220 Rojas Drive, Suite 700, El Paso TX 79936 USA. Please include a note describing the malfunction and suspected cause of failure. The Company shall not be obligated to repair or replace units which are found to be defective because of damage, unreasonable use, modifications, or alterations occurring after the date of manufacture. In no case shall the Company be liable for any consequential or incidental damages for breach of this or any other Warranty, expressed or implied whatsoever, even if the loss or damage is caused by the Company's negligence or fault. Some states do not allow the exclusion or limitation of incidental or consequential damages, so the above limitation or exclusion may not apply to you. This Warranty gives you specific legal rights, and you may also have other rights which vary from state to state.

System Sensor® is a registered trademark of Honeywell International, Inc.



Indoor Selectable-Output Horns, Strobes, and Horn Strobes for Wall Applications

System Sensor L-Series audible visible notification products are rich with features guaranteed to cut installation times and maximize profits with lower current draw and modern aesthetics.

Features

- Updated Modern Aesthetics
- Small profile devices for Horns and Horn Strobes
- Plug-in design with minimal intrusion into the back box
- Tamper-resistant construction
- Automatic selection of 12- or 24-volt operation at 15 and 30 candela
- Field-selectable candela settings on wall units: 15, 30, 75, 95, 110, 135, and 185
- Horn rated at 88+ dBA at 16 volts
- Rotary switch for horn tone and two volume selections
- Mounting plate for all standard and all compact wall units
- Mounting plate shorting spring checks wiring continuity before device installation
- Electrically compatible with legacy SpectrAlert and SpectrAlert Advance devices
- Compatible with MDL3 sync module
- Strobes and Horn Strobes listed for wall mounting only
- Horns listed for wall or ceiling use

Agency Listings



S5512
S4011



FM approved except
for ALERT models
3057383, 3057072



7125-1653:0504
7135-1653:0503



The System Sensor L-Series offers the most versatile and easy-to-use line of horns, strobes, and horn strobes in the industry with lower current draws and modern aesthetics. With white and red plastic housings, standard and compact devices, and plain, FIRE, and FUEGO-printed devices, System Sensor L-Series can meet virtually any application requirement.

The L-Series line of wall-mount horns, strobes, and horn strobes include a variety of features that increase their application versatility while simplifying installation. All devices feature plug-in designs with minimal intrusion into the back box, making installations fast and foolproof while virtually eliminating costly and time-consuming ground faults.

To further simplify installation and protect devices from construction damage, the L-Series utilizes a universal mounting plate for all models with an onboard shorting spring, so installers can test wiring continuity before the device is installed.

Installers can also easily adapt devices to a suit a wide range of application requirements using field-selectable candela settings, automatic selection of 12- or 24-volt operation, and a rotary switch for horn tones with two volume selections.

L-Series Specifications

Architect/Engineer Specifications

General

L-Series standard horns, strobes, and horn strobes shall mount to a standard 2 x 4 x 1⁷/₈-inch back box, 4 x 4 x 1¹/₂-inch back box, 4-inch octagon back box, or double-gang back box. L-Series compact products shall mount to a single-gang 2 x 4 x 1⁷/₈-inch back box. A universal mounting plate shall be used for mounting ceiling and wall products for all standard models and a separate universal mounting plate shall be used for mounting wall compact models. The notification appliance circuit wiring shall terminate at the universal mounting plate. Also, L-Series products, when used with the Sync•Circuit™ Module accessory, shall be powered from a non-coded notification appliance circuit output and shall operate on a nominal 12 or 24 volts. When used with the Sync•Circuit Module, 12-volt-rated notification appliance circuit outputs shall operate between 8.5 and 17.5 volts; 24-volt-rated notification appliance circuit outputs shall operate between 16.5 and 33 volts. Indoor L-Series products shall operate between 32 and 120 degrees Fahrenheit from a regulated DC or full-wave rectified unfiltered power supply. Strobes and horn strobes shall have field-selectable candela settings including 15, 30, 75, 95, 110, 135, and 185.

Strobe

The strobe shall be a System Sensor L-Series Model _____ listed to UL 1971 and shall be approved for fire protective service. The strobe shall be wired as a primary-signaling notification appliance and comply with the Americans with Disabilities Act requirements for visible signaling appliances, flashing at 1 Hz over the strobe's entire operating voltage range. The strobe light shall consist of a xenon flash tube and associated lens/reflector system.

Horn Strobe Combination

The horn strobe shall be a System Sensor L-Series Model _____ listed to UL 1971 and UL 464 and shall be approved for fire protective service. The horn strobe shall be wired as a primary-signaling notification appliance and comply with the Americans with Disabilities Act requirements for visible signaling appliances, flashing at 1 Hz over the strobe's entire operating voltage range. The strobe light shall consist of a xenon flash tube and associated lens/reflector system. The horn shall have two audibility options and an option to switch between a temporal three pattern and a non-temporal (continuous) pattern. These options are set by a multiple position switch. The horn on horn strobe models shall operate on a coded or non-coded power supply.

Synchronization Module

The module shall be a System Sensor Sync•Circuit model MDL3 listed to UL 464 and shall be approved for fire protective service. The module shall synchronize Strobes at 1 Hz and horns at temporal three. Also, while operating the strobes, the module shall silence the horns on horn strobe models over a single pair of wires. The module shall mount to a 4¹¹/₁₆ x 4¹¹/₁₆ x 2¹/₈-inch back box. The module shall also control two Style Y (class B) circuits or one Style Z (class A) circuit. The module shall synchronize multiple zones. Daisy chaining two or more synchronization modules together will synchronize all the zones they control. The module shall not operate on a coded power supply.

Physical/Electrical Specifications

Standard Operating Temperature	32°F to 120°F (0°C to 49°C)
Humidity Range	10 to 93% non-condensing
Strobe Flash Rate	1 flash per second
Nominal Voltage	Regulated 12 DC or regulated 24 DC/FWR ¹
Operating Voltage Range²	8 to 17.5 V (12 V nominal) or 16 to 33 V (24 V nominal)
Operating Voltage Range MDL3 Sync Module	8.5 to 17.5 V (12 V nominal) or 16.5 to 33 V (24 V nominal)
Input Terminal Wire Gauge	12 to 18 AWG
Wall-Mount Dimensions (including lens)	5.6" L x 4.7" W x 1.91" D (143 mm L x 119 mm W x 49 mm D)
Compact Wall-Mount Dimensions (including lens)	5.26" L x 3.46" W x 1.91" D (133 mm L x 88 mm W x 49 mm D)
Horn Dimensions	5.6" L x 4.7" W x 1.25" D (143 mm L x 119 mm W x 32 mm D)
Compact Horn Dimensions	5.25" L x 3.45" W x 1.25" D (133 mm L x 88 mm W x 32 mm D)

1. Full Wave Rectified (FWR) voltage is a non-regulated, time-varying power source that is used on some power supply and panel outputs.

2. Strobe products will operate at 12 V nominal only for 15 cd and 30 cd.

UL Current Draw Data

UL Max. Strobe Current Draw (mA RMS)				
Candela Range	Candela	8–17.5 Volts		
		DC	16–33 Volts DC	FWR
Candela Range	15	88	43	60
	30	143	63	83
	75	N/A	107	136
	95	N/A	121	155
	110	N/A	148	179
	135	N/A	172	209
	185	N/A	222	257

UL Max. Horn Current Draw (mA RMS)				
Sound Pattern	dB	8–17.5 Volts		
		DC	16–33 Volts DC	FWR
Temporal	High	39	44	54
Temporal	Low	28	32	54
Non-Temporal	High	43	47	54
Non-Temporal	Low	29	32	54
3.1 KHz Temporal	High	39	41	54
3.1 KHz Temporal	Low	29	32	54
3.1 KHz Non-Temporal	High	42	43	54
3.1 KHz Non-Temporal	Low	28	29	54
Coded	High	43	47	54
3.1 KHz Coded	High	42	43	54

UL Max. Current Draw (mA RMS), Wall Horn Strobe, Candela Range (15–185 cd)										
DC Input	8–17.5 Volts		16–33 Volts							
	15cd	30cd	15cd	30cd	75cd	95cd	110cd	135cd	185cd	
Temporal High	98	158	54	74	121	142	162	196	245	
Temporal Low	93	154	44	65	111	133	157	184	235	
Non-Temporal High	106	166	73	94	139	160	182	211	262	
Non-Temporal Low	93	156	51	71	119	139	162	190	239	
3.1K Temporal High	93	156	53	73	119	140	164	190	242	
3.1K Temporal Low	91	154	45	66	112	133	160	185	235	
3.1K Non-Temporal High	99	162	69	90	135	157	175	208	261	
3.1K Non-Temporal Low	93	156	52	72	119	138	162	192	242	
FWR Input	16–33 Volts									
	15cd	30cd	75cd	95cd	110cd	135cd	185cd			
Temporal High	83	107	156	177	198	234	287			
Temporal Low	68	91	145	165	185	223	271			
Non-Temporal High	111	135	185	207	230	264	316			
Non-Temporal Low	79	104	157	175	197	235	283			
3.1K Temporal High	81	105	155	177	196	234	284			
3.1K Temporal Low	68	90	145	166	186	222	276			
3.1K Non-Temporal High	104	131	177	204	230	264	326			
3.1K Non-Temporal Low	77	102	156	177	199	234	291			

Horn Tones and Sound Output Data

Horn and Horn Strobe Output (dBA)					
Switch Position	Sound Pattern	dB	8–17.5 Volts	16–33 Volts	FWR
			DC	DC	
1	Temporal	High	84	89	89
2	Temporal	Low	75	83	83
3	Non-Temporal	High	85	90	90
4	Non-Temporal	Low	76	84	84
5	3.1 KHz Temporal	High	83	88	88
6	3.1 KHz Temporal	Low	76	82	82
7	3.1 KHz Non-Temporal	High	84	89	89
8	3.1 KHz Non-Temporal	Low	77	83	83
9*	Coded	High	85	90	90
10*	3.1 KHz Coded	High	84	89	89

* Settings 9 and 10 are not available on 2-wire horn strobes. Temporal coding must be provided by the NAC. If the NAC voltage is held constant, the horn output remains constantly on.

L-Series Dimensions

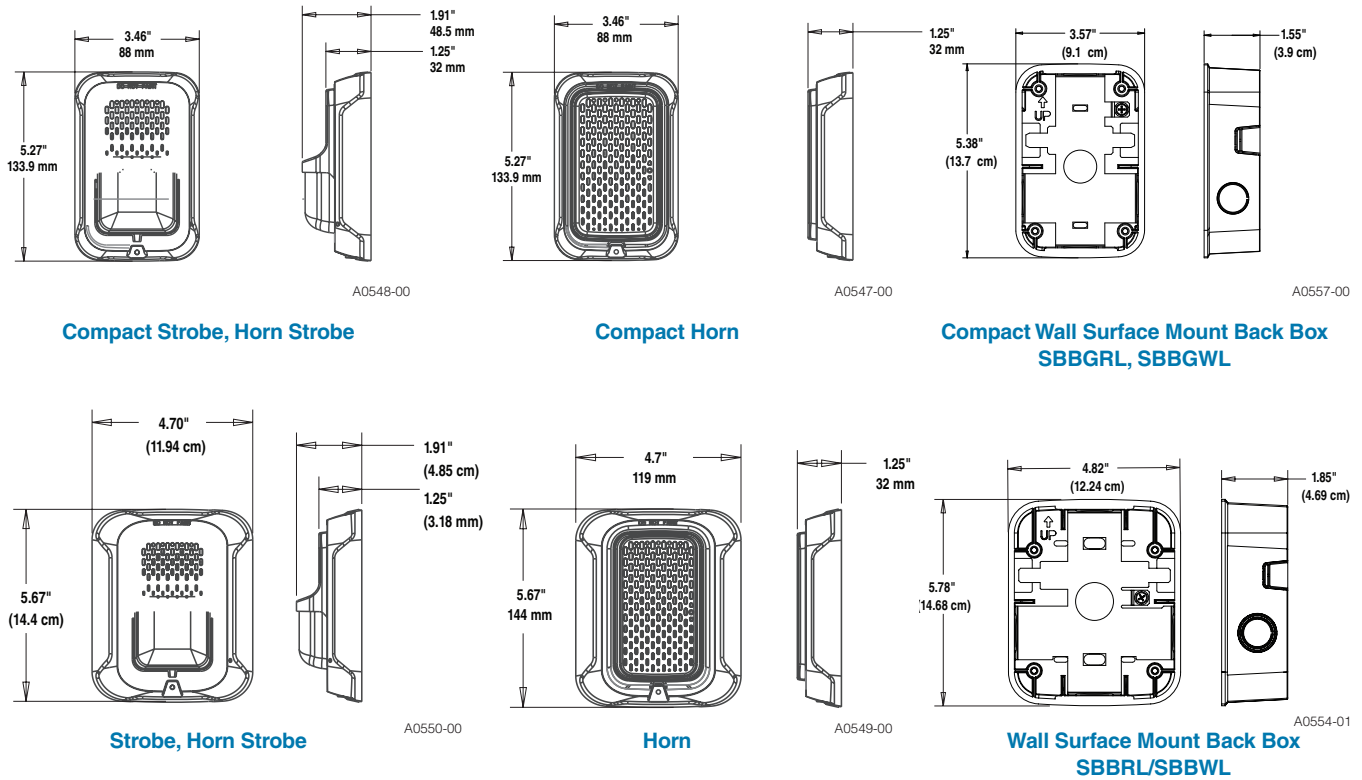

L-Series Ordering Information

Model	Description
Wall Horn Strobes	
P2RL	2-Wire, Horn Strobe, Red
P2WL	2-Wire, Horn Strobe, White
P2GRL	2-Wire, Compact Horn Strobe, Red
P2GWL	2-Wire, Comp 2 fils act Horn Strobe, White
P2RL-P	2-Wire, Horn Strobe, Red, Plain
P2WL-P	2-Wire, Horn Strobe, White, Plain
P2RL-SP	2-Wire, Horn Strobe, Red, FUEGO
P2WL-SP	2-Wire, Horn Strobe, White, FUEGO
P4RL	4-Wire, Horn Strobe, Red
P4WL	4-Wire, Horn Strobe, White
Wall Strobes	
SRL	Strobe, Red
SWL	Strobe, White
SGRL	Compact Strobe, Red
SGWL	Compact Strobe, White
SRL-P	Strobe, Red, Plain
SWL-P	Strobe, White, Plain
SRL-SP	Strobe, Red, FUEGO
SWL-CLR-ALERT	Strobe, White, ALERT

Model	Description
Horns*	
HRL*	Horn, Red
HWL*	Horn, White
HGRL*	Compact Horn, Red
HGWL*	Compact Horn, White
Accessories	
TR-2	Universal Wall Trim Ring Red
TR-2W	Universal Wall Trim Ring White
SBBRL	Wall Surface Mount Back Box, Red
SBBWL	Wall Surface Mount Back Box, White
SBBGRL	Compact Wall Surface Mount Back Box, Red
SBBGWL	Compact Wall Surface Mount Back Box, White

Notes:

All -P models have a plain housing (no "FIRE" marking on cover).
 All -SP models have "FUEGO" marking on cover.
 All -ALERT models have "ALERT" marking on cover.
 *Horn-only models are listed for wall or ceiling use.



3825 Ohio Avenue • St. Charles, IL 60174
 Phone: 800-SENSOR2 • Fax: 630-377-6495
www.systemsensor.com

©2018 System Sensor.
 Product specifications subject to change without notice. Visit systemsensor.com
 for current product information, including the latest version of this data sheet.
 AVDS865-05 • 2/22/2018



Indoor Selectable-Output Strobes and Horn Strobes for Ceiling Applications

System Sensor L-Series audible visible notification products are rich with features guaranteed to cut installation times and maximize profits with lower current draw and modern aesthetics.



Features

- Plug-in design with minimal intrusion into the back box
- Tamper-resistant construction
- Automatic selection of 12- or 24-volt operation at 15 and 30 candela
- Field-selectable candela settings on ceiling units: 15, 30, 75, 95, 115, 150, and 177
- Horn rated at 88+ dBA at 16 volts
- Rotary switch for horn tone and two volume selections
- Universal mounting plate for ceiling units
- Mounting plate shorting spring feature checks wiring continuity before device installation
- Electrically Compatible with legacy SpectrAlert and SpectrAlert Advance devices
- Compatible with MDL3 sync module
- Listed for ceiling mounting only

The System Sensor L-Series offers the most versatile and easy-to-use line of horns, strobes, and horn strobes in the industry with lower current draws and modern aesthetics. With white and red plastic housings, wall and ceiling mounting options, System Sensor L-Series can meet virtually any application requirement.

The entire L-Series product line of ceiling-mount strobes and horn strobes include a variety of features that increase their application versatility while simplifying installation. All devices feature a plug-in design with minimal intrusion into the back box, making installations fast and foolproof while virtually eliminating costly and time-consuming ground faults.

To further simplify installation, the L-Series utilizes a universal mounting plate so installers can mount them to a wide array of back boxes. With an onboard shorting spring, installers can test wiring continuity before the device is installed.

Installers can also easily adapt devices to a suit a wide range of application requirements using field-selectable candela settings, automatic selection of 12- or 24-volt operation, and a rotary switch for horn tones with two volume selections.

Agency Listings



L-Series Specifications

Architect/Engineer Specifications

General

L-Series ceiling-mount strobes and horn strobes shall mount to a standard 4 × 4 × 1½-inch back box, 4-inch octagon back box, or double-gang back box. Two-wire products shall also mount to a single-gang 2 × 4 × 17/8-inch back box. A universal mounting plate shall be used for mounting ceiling and wall products. The notification appliance circuit wiring shall terminate at the universal mounting plate. Also, L-Series products, when used with the Sync•Circuit™ Module accessory, shall be powered from a non-coded notification appliance circuit output and shall operate on a nominal 12 or 24 volts. When used with the Sync•Circuit Module, 12-volt-rated notification appliance circuit outputs shall operate between 8.5 and 17.5 volts; 24-volt-rated notification appliance circuit outputs shall operate between 16.5 and 33 volts. Indoor L-Series products shall operate between 32 and 120 degrees Fahrenheit from a regulated DC or full-wave rectified unfiltered power supply. Ceiling strobes and horn strobes shall have field-selectable candela settings including 15, 30, 75, 95, 115, 150, and 177.

Strobe

The strobe shall be a System Sensor L-Series Model _____ listed to UL 1971 and shall be approved for fire protective service. The strobe shall be wired as a primary-signaling notification appliance and comply with the Americans with Disabilities Act requirements for visible signaling appliances, flashing at 1 Hz over the strobe's entire operating voltage range. The strobe light shall consist of a xenon flash tube and associated lens/reflector system.

Horn Strobe Combination

The horn strobe shall be a System Sensor L-Series Model _____ listed to UL 1971 and UL 464 and shall be approved for fire protective service. The horn strobe shall be wired as a primary-signaling notification appliance and comply with the Americans with Disabilities Act requirements for visible signaling appliances, flashing at 1 Hz over the strobe's entire operating voltage range. The strobe light shall consist of a xenon flash tube and associated lens/reflector system. The horn shall have two audibility options and an option to switch between a temporal three pattern and a non-temporal (continuous) pattern. These options are set by a multiple position switch. The horn on horn strobe models shall operate on a coded or non-coded power supply.

Synchronization Module

The module shall be a System Sensor Sync•Circuit model MDL3 listed to UL 464 and shall be approved for fire protective service. The module shall synchronize L-Series strobes at 1 Hz and horns at temporal three. Also, while operating the strobes, the module shall silence the horns on horn strobe models over a single pair of wires. The module shall mount to a 4 11/16 × 4 11/16 × 2 1/8-inch back box. The module shall also control two Style Y (class B) circuits or one Style Z (class A) circuit. The module shall synchronize multiple zones. Daisy chaining two or more synchronization modules together will synchronize all the zones they control. The module shall not operate on a coded power supply.

Physical/Electrical Specifications

Standard Operating Temperature	32°F to 120°F (0°C to 49°C)
Humidity Range	10 to 93% non-condensing
Strobe Flash Rate	1 flash per second
Nominal Voltage	Regulated 12 VDC or regulated 24 DC/FWR ¹
Operating Voltage Range²	8 to 17.5 V (12 V nominal) or 16 to 33 V (24 V nominal)
Operating Voltage Range (MDL3)	8.5 to 17.5V (12 V nominal) or 16.5 to 33 V (24V nominal)
Input Terminal Wire Gauge	12 to 18 AWG
Ceiling-Mount Dimensions (including lens)	6.8" diameter × 2.5" high (173 mm diameter × 64 mm high)
Ceiling-Mount Surface Mount Back Box Skirt Dimensions (SBBCRL, SBBCWL)	6.9" diameter x 3.4" high (175 mm diameter x 86 mm high)

Notes:

1. Full Wave Rectified (FWR) voltage is a non-regulated, time-varying power source that is used on some power supply and panel outputs.
2. P, S, PC, and SC products will operate at 12 V nominal only for 15 and 30 cd.

UL Current Draw Data

UL Max. Strobe Current Draw (mA RMS)				
Candela Range	Candela	8-17.5 Volts		16-33 Volts
		DC	DC	FWR
Candela Range	15	87	41	60
	30	153	63	86
	75	N/A	111	142
	95	N/A	134	164
	115	N/A	158	191
	150	N/A	189	228
	177	N/A	226	264

UL Max. Horn Current Draw (mA RMS)				
Sound Pattern	dB	8-17.5 Volts		16-33 Volts
		DC	DC	FWR
Temporal	High	39	44	54
Temporal	Low	28	32	54
Non-Temporal	High	43	47	54
Non-Temporal	Low	29	32	54
3.1 KHz Temporal	High	39	41	54
3.1 KHz Temporal	Low	29	32	54
3.1 KHz Non-Temporal	High	42	43	54
3.1 KHz Non-Temporal	Low	28	29	54
Coded	High	43	47	54
3.1 KHz Coded	High	42	43	54

UL Max. Current Draw (mA RMS), Ceiling Horn Strobe, Candela Range (15-177 cd)										
DC Input	8-17.5 Volts		16-33 Volts							
	15cd	30cd	15cd	30cd	75cd	95cd	115cd	150cd	177cd	
Temporal High	103	167	71	90	143	165	187	217	254	
Temporal Low	96	165	54	71	137	161	185	211	249	
Non-Temporal High	106	173	71	90	141	165	187	230	273	
Non-Temporal Low	95	166	54	71	124	161	170	216	258	
3.1K Temporal High	111	164	69	94	147	163	184	229	257	
3.1K Temporal Low	103	163	54	88	143	155	185	212	252	
3.1K Non-Temporal High	111	172	69	94	144	164	202	229	271	
3.1K Non-Temporal Low	103	169	54	88	131	155	187	217	259	

FWR Input	16-33 Volts						
	15cd	30cd	75cd	95cd	115cd	150cd	177cd
Temporal High	107	135	179	198	223	254	286
Temporal Low	78	101	151	172	199	229	262
Non-Temporal High	107	135	179	198	223	254	286
Non-Temporal Low	78	101	151	172	199	229	262
3.1K Temporal High	108	135	179	200	225	255	289
3.1K Temporal Low	79	101	150	171	196	229	260
3.1K Non-Temporal High	108	135	179	200	225	255	289
3.1K Non-Temporal Low	79	101	150	171	196	229	260

Horn Strobe Tones and Sound Output Data

Horn Strobe Output (dBA)					
Switch Position	Sound Pattern	dB	8-17.5 Volts	16-33 Volts	FWR
			DC	DC	
1	Temporal	High	84	89	89
2	Temporal	Low	75	83	83
3	Non-Temporal	High	85	90	90
4	Non-Temporal	Low	76	84	84
5	3.1 KHz Temporal	High	83	88	88
6	3.1 KHz Temporal	Low	76	82	82
7	3.1 KHz Non-Temporal	High	84	89	89
8	3.1 KHz Non-Temporal	Low	77	83	83

L-Series Dimensions

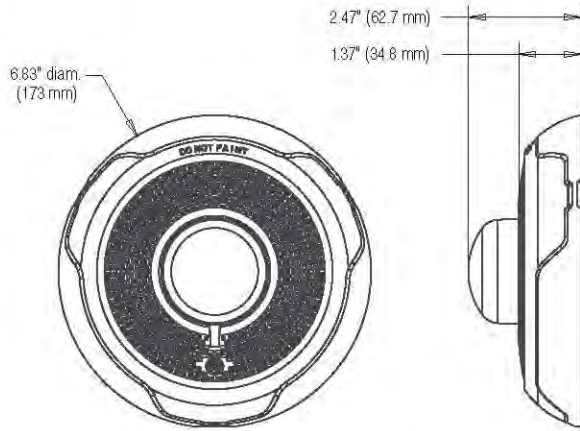

Ceiling-Mount Horn Strobes

A0545-00

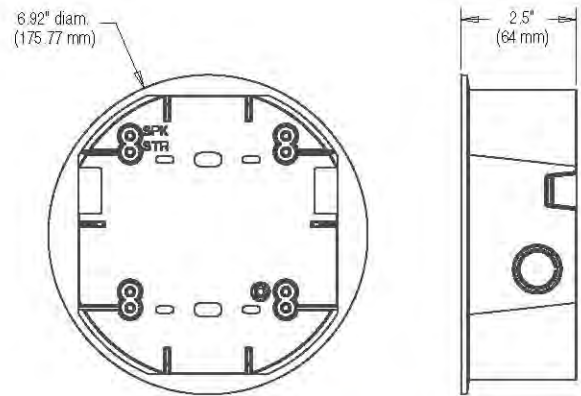

Ceiling Surface Mount Back Box

A0546-00

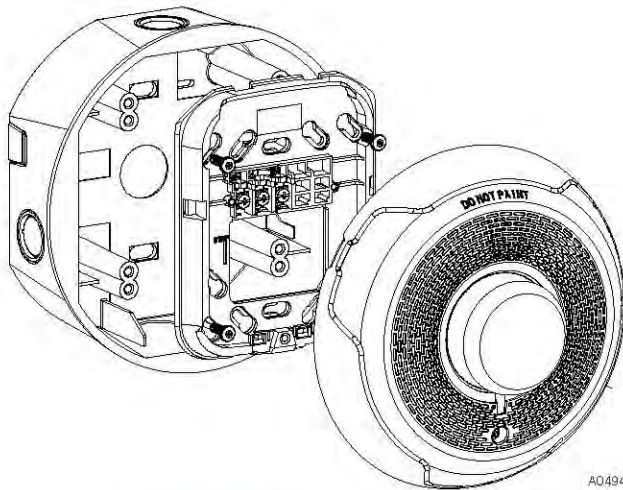

2-Wire Ceiling Mount Horn Strobes
with Ceiling Surface Mount Back Box

A0494-01

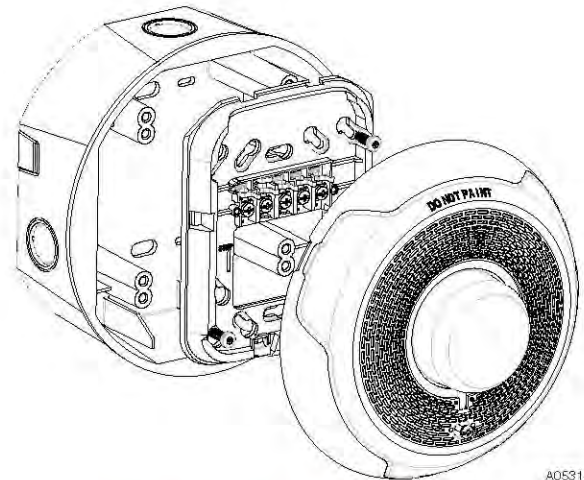

4-Wire Ceiling Mount Horn Strobes
with Ceiling Surface Mount Back Box

A0531-01

L-Series Ordering Information

Model	Description
Ceiling Horn Strobes	
PC2RL	2-Wire, Horn Strobe, Red
PC2WL	2-Wire, Horn Strobe, White
PC4RL	4-Wire, Horn Strobe, Red
PC4WL	4-Wire, Horn Strobe, White



Model	Description
Ceiling Strobes	
SCRL	Strobe, Red
SCWL	Strobe, White
SCWL-CLR-ALERT	Strobe, White, ALERT
Accessories	
TRC-2	Universal Ceiling Trim Ring Red
TRC-2W	Universal Ceiling Trim Ring White
SBBCRL	Ceiling Surface Mount Back Box, Red
SBBCWL	Ceiling Surface Mount Back Box, White

For a ceiling-listed horn-only device, see AVDS865 "Indoor Selectable-Output Horns, Strobes, and Horn Strobes for Wall Applications".



3825 Ohio Avenue • St. Charles, IL 60174
Phone: 800-SENSOR2 • Fax: 630-377-6495

©2017 System Sensor.
Product specifications subject to change without notice. Visit systemsensord.com
for current product information, including the latest version of this data sheet.
AVDS868-02 • 12/01/2017



Indoor Selectable-Output Speaker Strobes and Dual Voltage Evacuation Speakers for Wall Applications

System Sensor L-Series selectable output speaker strobes and dual-voltage evacuation speakers can reduce ground faults and enable faster installation with lower current draw and modern aesthetics.

Features

- ♦ Plug-in design and protective cover reduce ground faults
- ♦ Universal mounting plate with an onboard shorting spring tests wiring continuity before installation
- ♦ No extension ring required
- ♦ Field selectable candela settings on wall units: 15, 30, 75, 95, 110, 135, 185
- ♦ Automatic selection of 12- or 24-volt operation at 15 and 30 candela
- ♦ Rotary switch simplifies field selection of speaker voltage (25 and 70.7 Vrms) and power settings (¼, ½, 1 and 2 watts)
- ♦ Speakers offer high fidelity and high volume sound output
- ♦ 520 Hz +/- 10% square wave tone capable with compatible FACP
- ♦ Compatible with System Sensor synchronization protocol
- ♦ Electrical compatibility with existing SpectrAlert and SpectrAlert Advance products
- ♦ Tamper-resistant construction
- ♦ Updated modern aesthetics

Agency Listings



File approved except for ALERT models 3057483

720-1688-0505



The System Sensor L-Series of speakers and speaker strobes reduce costly ground faults using a plug-in design and universal mounting plate that allow the installer to pre-wire mounting plates, dress the wires, and confirm wiring continuity before plugging in the speakers. In addition, a protective plastic cover prevents nicked wires by covering exposed speaker components.

These devices also enable faster installations by providing instant feedback to ensure that wiring is properly connected, rotary switches to select voltage and power settings, and 7 field-selectable candela settings for wall speaker strobes.

The low total harmonic distortion of the speaker offers high fidelity sound output while still offering high volume sound output for use in high ambient noise applications.

System Sensor L-Series makes Installation easy

- ♦ Attach a universal mounting plate to a 4 × 4 × 2¹/₈ inch back box. Flush-mount applications do not require an extension ring.
- ♦ Connect the notification appliance circuit or speaker wiring to the terminals on the mounting plate.
- ♦ Attach the speaker or speaker strobe to the mounting plate by inserting the product tabs into the mounting plate grooves. Hinge the device into position to lock the product pins into the mounting plate terminals. The device will temporarily hold in place with a catch until it is secured with a captured mounting screw.

L-Series Speaker and Speaker Strobe Specifications

Architectural/Engineering Specifications

General

L-Series speaker and speaker strobes shall mount to a 4 × 4 × 2¹/₈-inch back box. A universal mounting plate shall be used for mounting ceiling and wall products. The notification appliance circuit and amplifier wiring shall terminate at the universal mounting plate. Also, L-Series speaker strobes, when used with the Sync•Circuit™ Module accessory, shall be powered from a non-coded notification appliance circuit output and shall operate on a nominal 12 or 24 volts. When used with the Sync•Circuit Module, 12-volt rated notification appliance circuit outputs shall operate between 8.5 and 17.5 volts; 24-volt rated notification appliance circuit outputs shall operate between 16.5 and 33 volts. Indoor L-Series products shall operate between 32°F and 120°F from a regulated DC, or full-wave rectified, unfiltered power supply. Wall-mount speaker strobes shall have field-selectable candela settings including 15, 30, 75, 95, 110, 135, 185.

Speaker

The speaker shall be aSp System Sensor L-Series model _____ dual-voltage transformer speaker capable of operating at 25.0 or 70.7 nominal Vrms. It should be listed to UL 1480 and shall be approved for fire protective service. The speaker shall have a frequency range of 400 to 4,000 Hz and shall have an operating temperature between 32°F and 120°F. The speaker shall have power taps and voltage that are selected by rotary switches.

Speaker Strobe combination

The speaker strobe shall be a System Sensor L-Series model _____ listed to UL1480 and UL 1971 and be approved for fire protective signaling systems. The speaker shall be capable of operating at 25.0 or 70.7 nominal Vrms selected via rotary switch, and shall have a frequency range of 400 to 4,000 Hz. The speaker shall have power taps that are selected by rotary switch. The strobe shall comply with the NFPA 72 requirements for visible signaling appliances, flashing at 1 Hz over the strobe's entire operating voltage range. The strobe light shall consist of a xenon flash tube and associated lens/reflector system.

Synchronization Module

The module shall be a System Sensor Sync•Circuit model MDL3 listed to UL 464 and shall be approved for fire protective service. The module shall synchronize strobes at 1 Hz. The module shall mount to a 4¹/₁₆ × 4¹/₁₆ × 2¹/₈-inch back box. The module shall also control two Style Y (class B) circuits or one Style Z (class A) circuit. The module shall synchronize multiple zones. Daisy chaining two or more synchronization modules together will synchronize all the zones they control. The module shall not operate on a coded power supply.

Physical Specifications

Operating Temperature	32°F to 120°F (0°C to 49°C)		
Humidity Range	10 to 93% non-condensing		
Dimensions, Wall-Mount	Length	Width	Depth
SPL Speaker	6.5 in, 165 mm	5 in, 127 mm	0.97 in, 23 mm
With Surface Mount Back Box	6.6 in, 168 mm	5.1 in, 130 mm	3.2 in, 82 mm
SPSL Speaker/Strobe (Including lens and speaker)	6.5 in, 165 mm	5.0 in, 127 mm	2.3 in, 58 mm
With Surface Mount Back Box	6.6 in, 168 mm	5.1 in, 130 mm	4.5 in, 116 mm

*When using 12AWG, 14 AWG, or adding extra wires in the box, a deeper box or extension ring is recommended.

Electrical/Operating Specifications

Nominal Voltage (speakers)	25 Volts or 70.7 Volts (nominal)
Maximum Supervisory Voltage (speakers)	50 VDC
Strobe Flash Rate	1 flash per second
Nominal Voltage (strobes)	Regulated 12 VDC or regulated 24 DC/FWR ^{1,2}
Operating Voltage Range (includes fire alarm panels with built in sync)	8 to 17.5 V (12 V nominal) or 16 to 33 V (24 V nominal)
Operating Voltage with MDL3 Sync Module	8.5 to 17.5 V (12 V nominal) or 16.5 to 33 V (24 V nominal)
Frequency Range	400 to 4000 Hz ³
Power	¼, ½, 1, 2 watts

1. Full Wave Rectified (FWR) voltage is a non-regulated, time-varying power source that is used on some power supply and panel outputs.

2. Strobe products will operate at 12 V nominal only for 15 and 30 cd

3. 520 Hz +/- 10% square wave tone capable with compatible FACP.

UL Current Draw Data

UL Max Strobe Current Draw (mA RMS)			
Candela	8 to 17.5 Volts	16 to 33 Volts	
	DC	DC	FWR
15	88	43	60
30	143	63	83
75	N/A	107	136
95	N/A	121	155
110	N/A	148	179
135	N/A	172	209
185	N/A	222	257

Sound Output Speaker Strobe				
	¼ W	½ W	1 W	2 W
UL Reverberant (dBA @10 ft)	77	80	83	86
UL Anechoic (dBA @10 ft)	77	80	83	86

Sound Output Speaker				
	¼ W	½ W	1 W	2 W
UL Reverberant (dBA @10 ft)	79	82	85	88
UL Anechoic (dBA @10 ft)	79	82	85	88

L-Series Dimensions

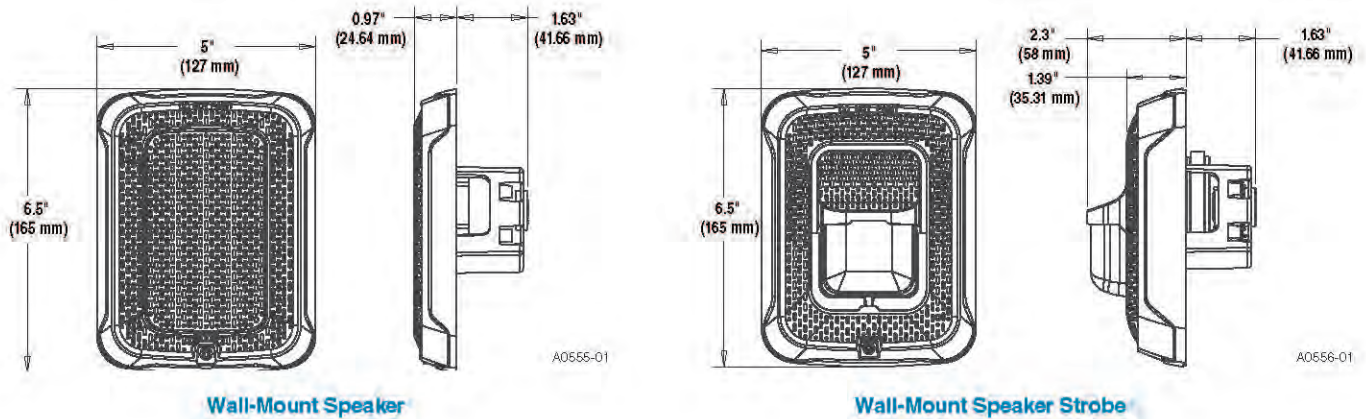

Surface Mounting

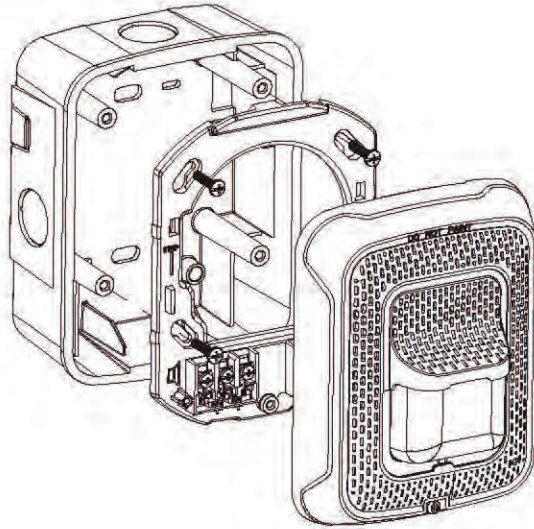

A0523-01

**Wall-Mount Speaker Strobe
with SBBSPRL/ SBBSPWL Surface Mount Back Box**

L-Series Ordering Information

Wall Mount		
White	Red	Description
SPWL	SPRL	Speaker only
SPSWL	SPSRL	Speaker Strobe
SPSWL-P	SPSRL-P	Plain Speaker Strobe
SPSWL-ALERT	—	Speaker Strobe, Amber Lens
SPSWL-CLR-ALERT	—	Speaker Strobe Clear Lens
—	SPSRL-SP	Speaker Strobe, Fuego

Accessories		
White	Red	Description
RFPW	RFP	7 in × 9.5 in Retrofit Plate
SBBSPWL	SBBSPRL	Surface Mount Back Box for Speakers and Speaker Strobes
TR-2W	TR-2	Wall Mount Trim Ring

Notes:

All -P models have a plain housing (no "FIRE" marking on the cover)



3825 Ohio Avenue • St. Charles, IL 60174
Phone: 800-SENSOR2 • Fax: 630-377-6495
www.systemsensor.com

©2018 System Sensor.
Product specifications subject to change without notice. Visit systemsensor.com
for current product information, including the latest version of this data sheet.
AVDS867-02 • 03/23/2018



Indoor Selectable-Output Speaker Strobes and Dual Voltage Evacuation Speakers for Ceiling Applications

System Sensor L-Series selectable-output speaker strobes and dual-voltage evacuation speakers can reduce ground faults and enable faster installation with lower current draw and modern aesthetics.

Features

- ♦ Plug-in design and protective cover reduce ground faults
- ♦ Universal mounting plate with an onboard shorting spring tests wiring continuity before installation
- ♦ No extension ring required
- ♦ Field selectable candela settings on ceiling units: 15, 30, 75, 95, 115, 150, and 177
- ♦ Automatic selection of 12- or 24-volt operation at 15 and 30 candela
- ♦ Rotary switch simplifies field selection of speaker voltage (25 and 70.7 Vrms) and power settings (¼, ½, 1 and 2 watts)
- ♦ Speakers offer high fidelity and high volume sound output
- ♦ 520 Hz +/- 10% square wave tone capable with compatible FACP
- ♦ Compatible with System Sensor synchronization protocol
- ♦ Electrical compatibility with existing SpectrAlert and SpectrAlert Advance products
- ♦ Tamper-resistant construction
- ♦ Updated modern aesthetics

Agency Listings



720-165-0505



System Sensor L-Series of speakers and speaker strobes reduce costly ground faults using a plug-in design and universal mounting plate that allow the installer to pre-wire mounting plates, dress the wires, and confirm wiring continuity before plugging in the speakers. In addition, a protective plastic cover prevents nicked wires by covering exposed speaker components.

These devices also enable faster installations by providing instant feedback to ensure that wiring is properly connected, rotary switches to select voltage and power settings, and 7 field-selectable candela settings for both wall and ceiling speaker strobes.

The low total harmonic distortion of the SP speaker offers high fidelity sound output while still offering high volume sound output for use in high ambient noise applications.

L-Series makes installation easy

- ♦ Attach a universal mounting plate to a 4 × 4 × 2¹/₈ inch back box. Flush-mount applications do not require an extension ring.
- ♦ Connect the notification appliance circuit or speaker wiring to the terminals on the mounting plate.
- ♦ Attach the speaker or speaker strobe to the mounting plate by inserting the product tabs into the mounting plate grooves. Hinge the device into position to lock the product pins into the mounting plate terminals. The device will temporarily hold in place with a catch until it is secured with a captured mounting screw.

L-Series Speaker and Speaker Strobe Specifications

Architectural/Engineering Specifications

General

L-Series speaker and speaker strobes shall mount to a 4 × 4 × 2¹/₈-inch back box. A universal mounting plate shall be used for mounting ceiling and wall products. The notification appliance circuit and amplifier wiring shall terminate at the universal mounting plate. Also, L-Series speaker strobes, when used with the Sync•Circuit™ Module accessory, shall be powered from a non-coded notification appliance circuit output and shall operate on a nominal 12 or 24 volts. When used with the Sync•Circuit Module, 12-volt rated notification appliance circuit outputs shall operate between 8.5 and 17.5 volts; 24-volt rated notification appliance circuit outputs shall operate between 16.5 and 33 volts. Indoor L-Series products shall operate between 32°F and 120°F from a regulated DC, or full-wave rectified, unfiltered power supply. Speaker strobes shall have field-selectable candela settings including 15, 30, 75, 95, 115, 150, 177.

Speaker

The speaker shall be a System Sensor L-Series model _____ dual-voltage transformer speaker capable of operating at 25.0 or 70.7 nominal Vrms. It should be listed to UL 1480 and shall be approved for fire protective service. The speaker shall have a frequency range of 400 to 4,000 Hz and shall have an operating temperature between 32°F and 120°F. The speaker shall have power taps and voltage that are selected by rotary switches.

Speaker Strobe combination

The speaker strobe shall be a System Sensor L-Series model _____ listed to UL1480 and UL 1971 and be approved for fire protective signaling systems. The speaker shall be capable of operating at 25.0 or 70.7 nominal Vrms selected via rotary switch, and shall have a frequency range of 400 to 4,000 Hz. The speaker shall have power taps that are selected by rotary switch. The strobe shall comply with the NFPA 72 requirements for visible signaling appliances, flashing at 1 Hz over the strobe's entire operating voltage range. The strobe light shall consist of a xenon flash tube and associated lens/reflector system.

Synchronization Module

The module shall be a System Sensor Sync•Circuit model MDL3 listed to UL 464 and shall be approved for fire protective service. The module shall synchronize SpectrAlert strobes at 1 Hz. The module shall mount to a 4¹¹/₁₆ × 4¹¹/₁₆ × 2¹/₈-inch back box. The module shall also control two Style Y (class B) circuits or one Style Z (class A) circuit. The module shall synchronize multiple zones. Daisy chaining two or more synchronization modules together will synchronize all the zones they control. The module shall not operate on a coded power supply.

Physical Specifications

Operating Temperature	32°F to 120°F (0°C to 49°C)	
Humidity Range	10 to 93% non-condensing	
Dimensions, Ceiling-Mount	Diameter	Depth
SPC Speaker	6.8 in, 173 mm	1.0 in, 25 mm
With Surface Mount Back Box	6.9 in, 176 mm	3.5 in, 89 mm
SPSC Speaker Strobe	6.8 in, 173 mm	2.8 in, 73 mm
With Surface Mount Back Box	6.9 in, 176 mm	5.37 in, 136 mm

*When using 12AWG, 14 AWG, or adding extra wires in the box, a deeper box or extension ring is recommended.

Electrical/Operating Specifications

Nominal Voltage (speakers)	25 Volts or 70.7 Volts (nominal)
Maximum Supervisory Voltage (speakers)	50 VDC
Strobe Flash Rate	1 flash per second
Nominal Voltage (strobes)	Regulated 12 VDC or regulated 24 VDC/FWR ^{1,2}
Operating Voltage Range (includes fire alarm panels with built in sync)	8 to 17.5 V (12 V nominal) or 16 to 33 V (24 V nominal)
Operating Voltage with MDL3 Sync Module	8.5 to 17.5 V (12 V nominal) or 16.5 to 33 V (24 V nominal)
Frequency Range	400 to 4,000 Hz ³
Power	¼, ½, 1, 2 watts

1. Full Wave Rectified (FWR) voltage is a non-regulated, time-varying power source that is used on some power supply and panel outputs.
2. Strobe products will operate at 12 V nominal only for 15 and 30 cd.
3. 520 Hz +/- 10% square wave tone capable with compatible FACP.

UL Current Draw Data

UL Max. Strobe Current Draw (mA RMS)			
	8 to 17.5 Volts	16 to 33 Volts	
Candela	DC	DC	FWR
15	87	41	60
30	153	63	86
75	NA	111	142
95	NA	134	164
115	NA	158	191
150	NA	189	228
177	NA	226	264

Ceiling-Mount Speaker Sound Output		
Setting	UL Reverberant (dBA @10 ft)	UL Anechoic (dBA @10 ft)
1/4 W	79	79
1/2 W	82	82
1 W	85	85
2 W	88	88

Ceiling-Mount Speaker Strobe Sound Output		
Setting	UL Reverberant (dBA @10 ft)	UL Anechoic (dBA @10 ft)
1/4 W	77	77
1/2 W	80	80
1 W	83	83
2 W	86	86

L-Series Dimensions

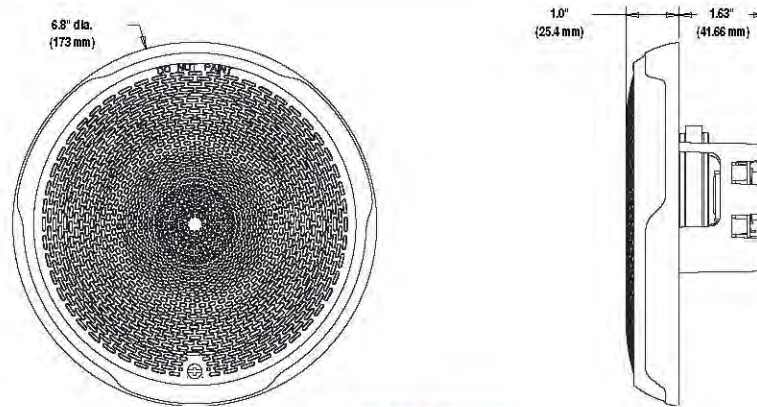

Ceiling Speaker

A0543-00

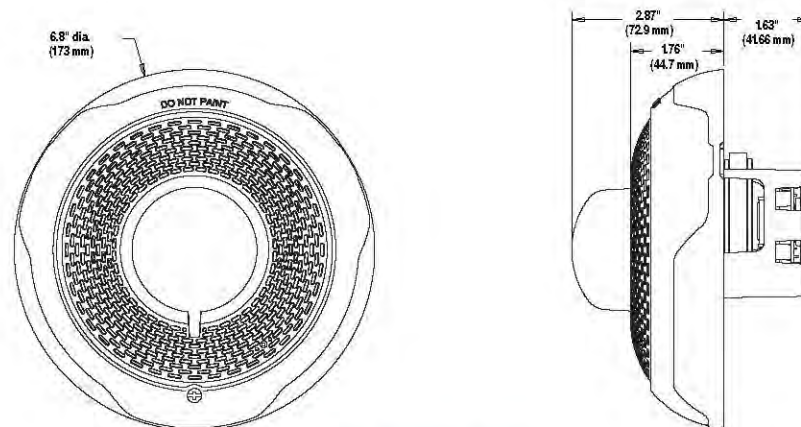

Ceiling Speaker Strobe

A0544-00

Surface Mounting

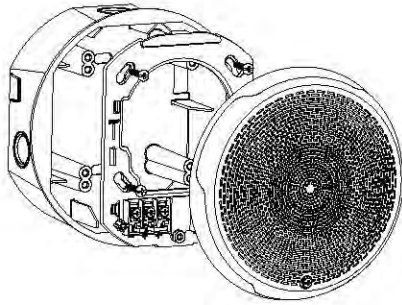

A0504-01

Ceiling Speaker with Surface Mount Back Box

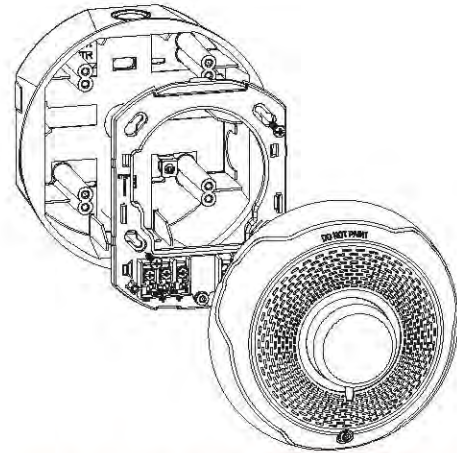

A0520-01

Ceiling Speaker Strobe with Surface Mount Back Box

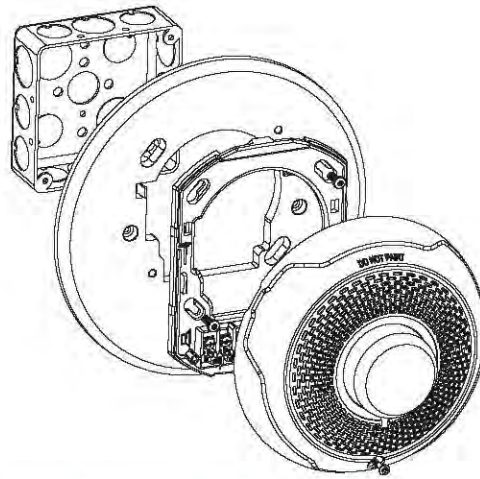

A0542-00

Ceiling Speaker Strobe with Trim Ring and 4" Square Electrical Box

L-Series Ordering Information

Ceiling Mount		
White	Red	Description
SPCWL	SPCRL	Speaker only
→ SPSCWL	SPSCRL	Speaker Strobe
SPSCWL-P	—	Plain, Speaker Strobe
SPSCWL-SP	—	Fuego, Speaker Strobe
SPSCWL-CLR-ALERT	—	Alert, Speaker Strobe, Clear Lens
Accessories		
White	Red	Description
SBBCWL	SBBCRL	Universal Ceiling Surface Mount Back Box
TRC-2W	TRC-2	Universal Ceiling Trim Ring



3825 Ohio Avenue • St. Charles, IL 60174
 Phone: 800-SENSOR2 • Fax: 630-377-6495
www.systemsensor.com

©2018 System Sensor.
 Product specifications subject to change without notice. Visit systemsensor.com
 for current product information, including the latest version of this data sheet.
 AVDS866-03 • 03/23/2018



Sealed Lead-Acid Batteries

BSL1075
(PC1270)

Capacity Specifications

Cut-off Voltage	20 Hr Rate (0.36 A)	7.2 Ah
1.75 v/c @ 25°C	10 Hr Rate (0.65 A)	6.5 Ah
1.70 v/c	5 Hr Rate (1.14 A)	5.7 Ah
1.55 v/c	1 Hr Rate (4.1 A)	4.1 Ah
	Bloc	Per Cell
Charge Voltage (constant)	Float	13.5~13.8
	Cycle	14.4~14.7
Discharge Current Amps (5 seconds maximum)	80	
Discharge Current Amps (maximum continuous)	50	
Max. Charge Current	2.16 A	
Approx Final Charge Current (2.25 v/c Float)	0.014 (14 mA)	
Approx Final Charge Current (2.45 v/c Cycle)	0.07 (70 mA)	
Terminal Type	Type A / (G optional)	
Self Discharge	9 months @ 21°C	
Case Material	ABS – Gray* or Black	

Due to changes in the manufacturing processes, specifications may change without notice.
*Gray option is Flame Retardant ABS.

Technical Specifications

Nominal Voltage	12V
Nominal Capacity	7.2 Ah (20 Hr Rate)
Dimensions	Length: 150 mm
	Width: 64.5 mm
	Height: 95 mm
Total Height/Terminal:	101 mm
Weight	Approx 2.75 Kg

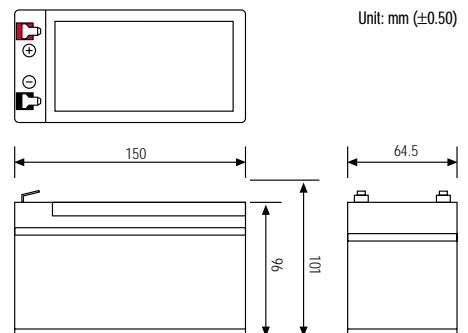

Actual Wattage / Ampere Capacity at Various Discharge Times (Volt per Cell @ 25°C)		5 Min.	10 min.	15 min.	30 min.	45 min.	60 min.
1.75 v/c	W	45.4	30.77	23.28	12.9	10.31	8.07
	A	25.94	17.58	13.3	7.37	5.89	4.61
1.67 v/c	W	47.76	31.4	23.9	13.09	10.04	8.07
	A	28.6	18.8	14.31	7.84	6.01	4.83
1.60 v/c	W	49.28	31.52	24.0	13.3	9.3	7.79
	A	30.8	19.7	15.0	8.31	5.81	4.87



Sealed Lead-Acid Batteries

BSL1105
(PC12100)

Capacity Specifications

Cut-off Voltage	20 Hr Rate (0.60 A)	12.0 Ah
1.75 v/c @ 25°C	10 Hr Rate (1.12 A)	11.2 Ah
1.70 v/c	5 Hr Rate (1.92 A)	9.6 Ah
1.55 v/c	1 Hr Rate (7.1 A)	7.1 Ah
	Bloc	Per Cell
Charge Voltage (constant)	Float	13.5~13.8
	Cycle	14.4~14.7
Discharge Current Amps (5 seconds maximum)	80	
Discharge Current Amps (maximum continuous)	50	
Max. Charge Current	3.6 A	
Approx Final Charge Current (2.25 v/c Float)	0.024 (24 mA)	
Approx Final Charge Current (2.45 v/c Cycle)	0.12 (120 mA)	
Terminal Type	Type A / (G optional)	
Self Discharge	9 months @ 21°C	
Case Material	ABS – Gray* or Black	

Due to changes in the manufacturing processes, specifications may change without notice.
*Gray option is Flame Retardant ABS.

Technical Specifications

Nominal Voltage	12V
Nominal Capacity	12.0 Ah (20 Hr Rate)
Dimensions	Length: 150.5 mm
	Width: 97.5 mm
	Height: 96 mm
Total Height/Terminal:	102 mm
Weight	Approx 4.28 Kg

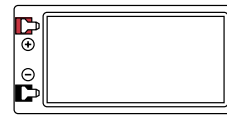

Unit: mm (±0.50)

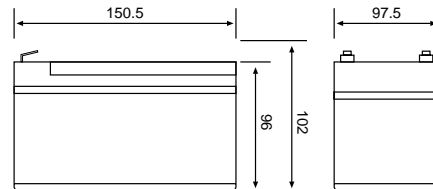

Actual Wattage / Ampere Capacity at Various Discharge Times (Volt per Cell @ 25°C)

Cut Off Voltage	Time	5 Min.	10 min.	15 min.	30 min.	45 min.	60 min.
		1.75 v/c	W	77.16	51.96	39.95	21.95
25°C	A	44.09	29.69	22.83	12.54	8.91	6.99
1.67 v/c	W	81.6	53.62	40.8	22.31	15.73	12.36
25°C	A	48.86	32.11	24.43	13.36	9.42	7.4
1.60 v/c	W	84.0	53.92	41.12	22.56	15.84	12.38
25°C	A	52.5	33.7	25.7	14.1	9.9	7.74



PRODUCT DATA SHEET

PART NUMBER: 81802
DESCRIPTION: 18/2 SOLID FPLP FT6 CABLE
CONSTRUCTION: This cable consists of two bare copper insulated conductors and an overall jacket.
APPROVALS: UL Standard 1424, NEC Article 760.
APPLICATION: Fire Alarm Power Limited Circuit Cable Used in Plenum Applications

Construction Parameters:

Cable Cross-Section

Conductor	18 AWG Bare Copper
Stranding	Solid
Insulation Material	Polymer Alloy
Insulation Thickness	0.006" Nom.
Insulated Conductor Diameter	0.052" Nom.
Number of Conductors	2
Lay Length	1.75" Nom.
Jacket Material	Low Smoke PVC
Jacket Thickness	0.016" Nom.
Overall Cable Diameter	0.136" Nom.
Approximate Cable Weight	17.4 Lbs/1M' Nom.
Flame Rating	UL 910 Steiner Tunnel Smoke and Flame Test



Electrical Properties:

Temperature Rating	-20°C to 75°C
Operating Voltage	300 V RMS Max.
Capacitance Between Conductors @ 1 KHz	50 pF/ft Nom.
Capacitance Between Conductors to Shield @ 1 KHz	-----
DC Resistance per Conductor @ 20°C	6.32 Ohms/1M' Nom.

Insulation Colors	Black Red
Jacket Color	Red (Other colors available for minimum order)

Legend (Surface Ink Print) E100315 * 18 AWG 2/C (UL) TYPE FPLP 75C -- C(UL) TYPE CMP FT6

On special orders, the customer will accept all factory lengths and +/- 10 percent of total order requested.

The jacket is sequentially footmarked.

The information presented here is, to the best of our knowledge, is true and accurate. However, since conditions of use are beyond our control, all recommendations or suggestions are presented without guarantee or responsibility on our part. We disclaim all liability in connection with the use of information contained herein or otherwise.

This specification is proprietary intellectual property of Coleman Cable. Any information contained herein shall not be disclosed to any party without written consent of Coleman Cable.

Customer Name _____

Customer Approval _____

Specification Issue Date: January 19, 2001



PRODUCT DATA SHEET

PART NUMBER: 81402
DESCRIPTION: 14/2 SOLID FPLP METRO CABLE
CONSTRUCTION: This cable consists of two bare copper insulated conductors and an overall jacket.
APPROVALS: UL Standard 1424, NEC Article 760.
APPLICATION: Fire Alarm Power Limited Circuit Cable Used in Plenum Applications

Construction Parameters:

Conductor	14 AWG Bare Copper
Stranding	Solid
Insulation Material	Polymer Alloy
Insulation Thickness	0.009" Nom.
Insulated Conductor Diameter	0.082" Nom.
Number of Conductors	2
Lay Length	1.75" Nom.
Jacket Material	Low Smoke PVC
Jacket Thickness	0.020" Nom.
Overall Cable Diameter	0.204" Nom.
Approximate Cable Weight	37.4 Lbs/1M' Nom.
Flame Rating	UL 910 Steiner Tunnel Smoke and Flame Test

Cable Cross-Section



Electrical & Environmental Properties:

Temperature Rating	-20°C to 75°C
Operating Voltage	300 V RMS Max.
Capacitance Between Conductors @ 1 KHz	54 pF/ft Nom.
Capacitance Between Conductors to Shield @ 1 KHz	-----
Inductance	0.07 uH/ft Nom.
DC Resistance per Conductor @ 20°C	2.54 Ohms/1M' Nom.

Insulation Colors	Black Red
Jacket Color	Red (Other colors available for minimum order)
Legend (Surface Ink Print)	E100315 * 14 AWG 2/C (UL) TYPE FPLP 75C

On special orders, the customer will accept all factory lengths and +/- 10 percent of total order requested.

The information presented here is, to the best of our knowledge, is true and accurate. However, since conditions of use are beyond our control, all recommendations or suggestions are presented without guarantee or responsibility on our part. We disclaim all liability in connection with the use of information contained herein or otherwise.

This specification is proprietary intellectual property of Coleman Cable. Any information contained herein shall not be disclosed to any party without written consent of Coleman Cable.

Customer Name _____ Date Signed _____

Customer Approval _____

Specification Issue Date: August 13, 2001

