

# Reliable®

## Model JL14 & JL17 ESFR Pendent Sprinklers

175 psi (12 bar) rated

### Features

- cULus, VdS, and LPCB listed as an ESFR sprinkler
- FM Approved as a quick-response, storage and non-storage sprinkler
- Fusible link operating element
- Compact design

### Product Description

The Reliable Models JL14 and JL17 are Early Suppression Fast Response (ESFR) Sprinklers with nominal K-factors of 14.0 (200 metric) and 16.8 (240 metric), respectively. The sprinklers use a levered fusible alloy solder link in either a 165°F (74°C) or a 212°F (100°C) temperature rating. These sprinklers are designed to respond quickly to growing fires and will deliver a heavy water discharge to “suppress” rather than “control” fires.

FM Approvals classifies the Model JL14 and JL17 as quick-response sprinklers, storage and non-storage, when used in accordance with FM Global Property Loss Prevention Data Sheets.

Model JL14 and JL17 ESFR sprinklers are designed to be shorter and more compact than other ESFR sprinklers, allowing greater flexibility with regard to distance from ceilings and obstructions. The JL14 and JL17 ESFR sprinklers are also less susceptible to damage due to smaller deflector and frame design. The lighter JL14 and JL17 ESFR sprinklers passed rough use and abuse listing tests without plastic protectors

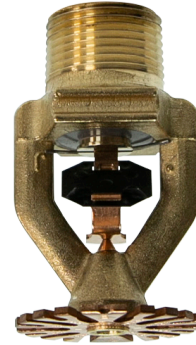

Model JL17 ESFR Sprinkler

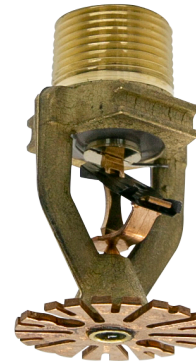

Model JL14 ESFR Sprinkler

### Models JL14 & JL17 ESFR Pendent Sprinklers

Table A

Model	Nominal K-factor gpm/psi <sup>1/2</sup> (L/min/bar <sup>1/2</sup> )	Approvals	Sprinkler Identification Number (SIN)
JL14	14.0 (200)	cULus, FM, VdS, LPCB, CNBOP-PIB	RA1812
JL17	16.8 (240)	cULus, FM, VdS, LPCB, CNBOP-PIB	RA1914

**Technical Specifications**

**Style:** Pendent  
**Connection:** 3/4" NPT or ISO7-1R3/4 (BSPT) threads  
**Nominal K-Factor:** 14.0 (200 metric)  
**Max. Working Pressure:** 175 psi (12 bar)

**Material Specifications**

**Thermal Sensor:** Beryllium Nickel Solder Link  
**Sprinkler Frame:** Brass Alloy  
**Cap:** Bronze Alloy  
**Sealing Assembly:** Nickel Alloy with PTFE  
**Load Screw:** Bronze Alloy  
**Deflector:** Bronze Alloy  
**Kick Spring:** Stainless Steel Alloy

**Sprinkler Finishes**

Bronze

**Sensitivity**

Fast-Response  
 Quick-Response (FM)

**Temperature Ratings**

Ordinary: 165°F (74°C)  
 Intermediate: 212°F (100°C)

**Sprinkler Wrench**

Model J1

**Guards & Shields**

Model S-3 Water Shield (FM)\*

**Listings and Approvals**

cULus  
 FM Approved  
 VdS  
 LPCB  
 CNBOP-PIB



**\*Note:** Model JL14 fire sprinkler is FM Approved with Model S-3 Water Shield for use as a pendent intermediate level sprinkler. Model S-3 Water Shield diameter is 3-3/4" (95mm).

**Model JL14 Sprinkler Components and Dimensions**

**Figure 1**

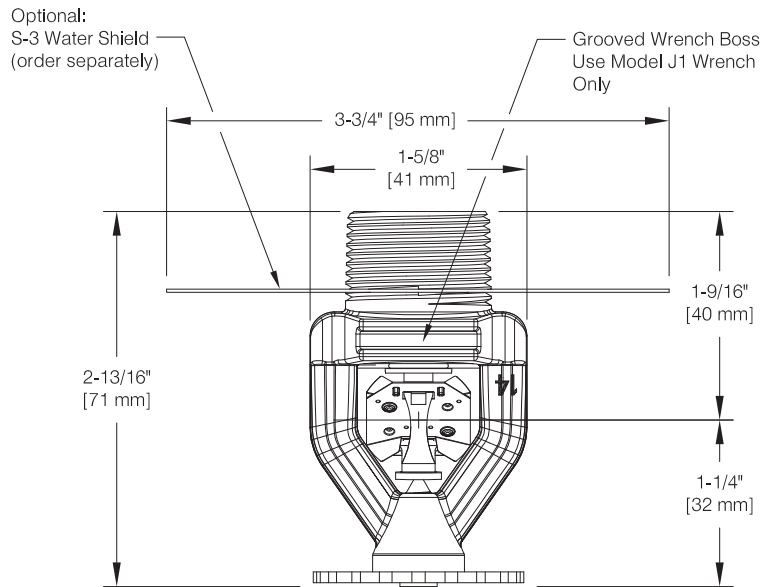

**Technical Specifications**

**Style:** Pendent  
**Connection:** 3/4" NPT or ISO7-1R3/4 (BSPT) threads  
**Nominal K-Factor:** 16.8 (240 metric)  
**Max. Working Pressure:** 175 psi (12 bar)

**Material Specifications**

**Thermal Sensor:** Beryllium Nickel Solder Link  
**Sprinkler Frame:** Brass Alloy  
**Cap:** Bronze Alloy  
**Sealing Assembly:** Nickel Alloy with PTFE  
**Load Screw:** Bronze Alloy  
**Deflector:** Bronze Alloy  
**Kick Spring:** Stainless Steel Alloy

**Sprinkler Finishes**

Bronze

**Sensitivity**

Fast-Response  
 Quick-Response (FM)

**Temperature Ratings**

Ordinary: 165°F (74°C)  
 Intermediate: 212°F (100°C)

**Sprinkler Wrench**

Model J1

**Guards & Shields**

Model S-3 Water Shield (FM)\*

**Listings and Approvals**

cULus  
 FM Approved  
 VdS  
 LPCB  
 CNBOP-PIB

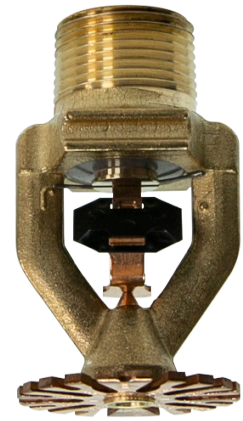

**\*Note:** Model JL17 fire sprinkler is FM Approved with Model S-3 Water Shield for use as a pendent intermediate level sprinkler. Model S-3 Water Shield diameter is 3-3/4" (95mm).

**Model JL17 Sprinkler Components and Dimensions**

**Figure 2**

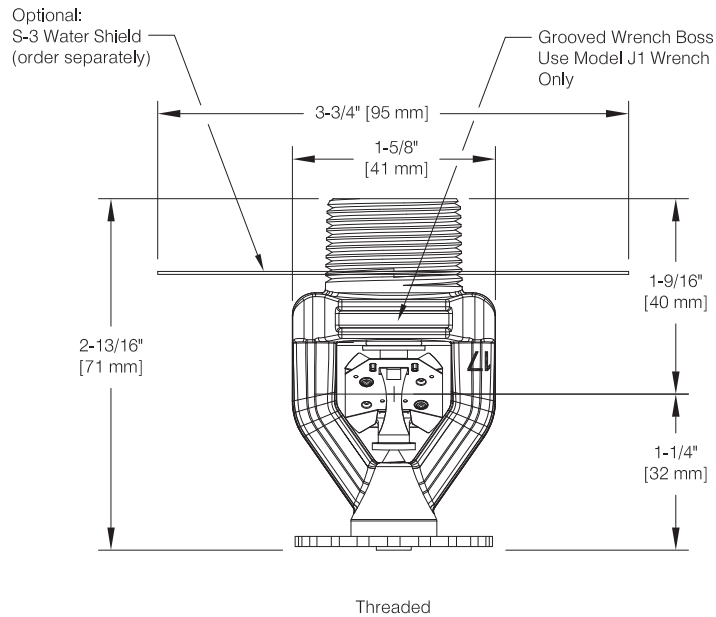

**Model JL14 and JL17 Commodity Selection and Design Criteria Overview**

**Table B**

<b>Storage Type</b>	<b>NFPA</b>	<b>FM GLOBAL</b>
Sprinkler Type	ESFR	Storage
Response Type	ESFR	Quick Response
System Type	Wet	Wet
Temperature Rating °F (°C)	165 (74), 212 (100)	165 (74), 212 (100)
Roof Construction	See NFPA 13	See FM Global 2-0
Ceiling Slope	See NFPA 13	See FM Global 2-0
Maximum Coverage Area	See NFPA 13	See FM Global 2-0
Minimum Coverage Area	See NFPA 13	See FM Global 2-0
Maximum Spacing	See NFPA 13	See FM Global 2-0
Minimum Spacing	See NFPA 13	See FM Global 2-0
Minimum Clearance to Commodity	See NFPA 13	See FM Global 2-0
Sprinkler Distance to Ceiling	See NFPA 13	See FM Global 2-0
Open Frame, Single, Double, Multiple Row, or Portable Rack Storage of Class I-IV Commodities and Group A Plastics	See NFPA 13	See FM 2-0 & 8-9
Solid Pile or Palletized Storage of Class I-IV Commodities and Group A Plastics	See NFPA 13	See FM 2-0 & 8-9
Idle Pallet Storage	See NFPA 13	See FM 2-0, 8-9 & 8-24
Rubber Tire Storage	See NFPA 13	See FM 2-0 & 8-3
Rolled Paper Storage	See NFPA 13	See FM 8-21
Flammable Liquid Storage	See NFPA 30	See FM 7-29
Aerosol Storage	See NFPA 30B	See FM 7-31
Auto Components in Portable Racks	See NFPA 13	See FM 2-0 and 8-9

## Installation

Model JL14 and JL17 sprinklers are intended for installation in accordance with NFPA 13 and FM Loss Prevention Data Sheets 2-0 and 8-9, as well as the requirements of any Authorities Having Jurisdiction. See Table B for information on NFPA and FM Global design criteria for the Model JL14 and JL17 sprinklers.

For threaded sprinklers only, use the Model J1 sprinkler wrench for removal and installation. Any other type of wrench may damage the sprinkler. A grooved wrench boss is provided on the sprinkler to limit the potential for the wrench to slip during installation.

When handling sprinklers, hold sprinklers only on frame arms and do not apply any force on the link assembly. Model JL14 and JL17 sprinklers should be tightened between 14 - 40 ft-lbs (19 - 54 N·m) torque. Sprinklers not tightened to recommended torque may cause leakage or impairment of the sprinkler. Damaged sprinklers must be replaced immediately.

**Caution:** When handling sprinklers, hold sprinklers only by the frame arms and do not apply any force on the link assembly.

## Maintenance

Model JL14 and JL17 ESFR Sprinklers should be inspected and the sprinkler system maintained in accordance with NFPA 25. Do not clean sprinkler with soap and water, ammonia or any other cleaning fluid. Replace any sprinkler that has been painted (other than factory applied) or damaged in any way. A stock of spare sprinklers should be maintained to allow quick replacement of damaged or operated sprinklers. Prior to installation, sprinklers should be maintained in the original cartons and packaging until used, to minimize the potential for damage to sprinklers that would cause improper operation or non-operation.

Once operated, automatic sprinklers cannot be reassembled and reused. New sprinklers of the same size, type and temperature rating must be installed. A cabinet of replacement sprinklers should be provided for this purpose.

## Listings and Approvals

1. UL Listed and ULC Certified for Canada (cULus)
2. FM Approved (FM)
3. VdS Certified (VdS)
4. Loss Prevention Certification Board Approved (LPCB)
5. CNBOP-PIB Technical Approval (CNBOP-PIB)

Model J1 Sprinkler Wrench

Figure 3



## Guarantee

For the Reliable Automatic Sprinkler Co., Inc. guarantee, terms, and conditions, visit [www.reliablesprinkler.com](http://www.reliablesprinkler.com).

## Ordering Information

### Specify

- Sprinkler: [JL14] [JL17]
- Temperature Rating: [165°F (64°C)] [212°F (100°C)]
- End Connection: [3/4" NPT] [ISO7-1R3/4 (BSPT)]

### Optional

- S-3 Water Shield (threaded sprinklers only)

# Mechanical-T<sup>®</sup> Bolted Branch Outlets

STYLES 920 AND 920N

Victaulic Mechanical-T<sup>®</sup> Outlet provides a direct branch connection at any location a hole can be cut in pipe. The hole is cut oversize to receive a “holefinder” locating collar which secures the outlet in position permanently. A pressure responsive gasket seals on the pipe O.D.

Cross-type connections can be achieved by utilizing two upper housings of the same style and size, with the same or differing branch size connections. NOTE: Style 920 and Style 920N housings cannot be mated to each other to achieve a cross connection.



Style 920 and Style 920N Mechanical-T outlets are available with grooved or female threaded outlet. Specify choice on order. Units are supplied painted with plated bolts. Galvanized housings are available, supplied with plated bolts.

All sizes of Style 920 and 920N are rated at 500 psi/3450 kPa working pressure on Schedule 10 and 40 carbon steel pipe. They may also be used on high density polyethylene or polybutylene (HDPE) pipe. Pressure ratings on HDPE are dependent on the pipe rating. Contact Victaulic for ratings on other pipe. **Style 920 and 920N are not recommended for use on PVC plastic pipe.**

Standard piping practices dictate that the Mechanical-T Styles 920 and 920N must be installed so that the main and branch connections are a true 90° angle when permanently attached to the pipeline surface.

Additionally, the Vic-Tap II<sup>®</sup> hole cutting tool, which allows for hole cutting capabilities on pressurized systems, utilizes the Style 920 Mechanical-T in conjunction with the Series 726 Vic-Ball Valve to create the Style 931 Vic-Tap II Mechanical-T unit. See page 8 for further information.



  
 EN 10311 BS EN 10311  
 CPR (EU) CPR (UK)  
 No. 305/2011 2019 No. 465

SEE VICTAULIC PUBLICATION 10.01 FOR DETAILS



STYLES 920 AND 920N



STYLE 920 CROSS

PATENTED

## MATERIAL SPECIFICATIONS

**Housing/Coating:** Ductile iron conforming to ASTM A-536, grade 65-45-12, with orange enamel coating. Ductile iron conforming to ASTM A-395, grade 65-45-15, is available upon special request.

- **Optional:** Hot dipped galvanized

**Gasket: (Specify choice\*)**

- **Grade “E” EPDM**

EPDM (Green color code). Temperature range -30°F to +230°F/-34°C to +110°C.

Recommended for cold and hot water service within the specified temperature range plus a variety of dilute acids, oil-free air and many chemical services. UL Classified in accordance with ANSI/NSF 61 for cold +86°F/+30°C and hot +180°F/+82°C. NOT RECOMMENDED FOR PETROLEUM SERVICES.

- **Grade “T” nitrile**

Nitrile (Orange color code). Temperature range -20°F to +180°F/-29°C to +82°C.

Recommended for petroleum products, air with oil vapors, vegetable and mineral oils within the specified temperature range. Not recommended for hot water services over +150°F/+66°C or for hot dry air over +140°F/+60°C.

\*Services listed are General Service Recommendations only. It should be noted that there are services for which these gaskets are not recommended. Reference should always be made to the latest Victaulic Gasket Selection Guide for specific gasket service recommendations and for a listing of services which are not recommended.

**Bolts/Nuts:** Heat-treated plated carbon steel, trackhead meeting the physical and chemical requirements of ASTM A-449 and physical requirements of ASTM A-183.

<b>JOB/OWNER</b>	<b>CONTRACTOR</b>	<b>ENGINEER</b>
System No. _____	Submitted By _____	Spec Sect _____ Para _____
Location _____	Date _____	Approved _____
		Date _____

www.victaulic.com

VICTAULIC IS A REGISTERED TRADEMARK OF VICTAULIC COMPANY. © 2022 VICTAULIC COMPANY. ALL RIGHTS RESERVED.

REV\_P



# Mechanical-T<sup>®</sup> Bolted Branch Outlets

STYLES 920 AND 920N

## DIMENSIONS

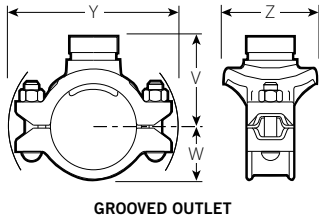

GROOVED OUTLET

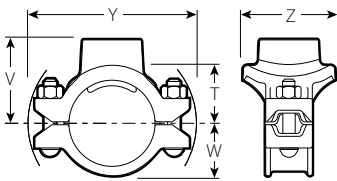

FEMALE THREADED OUTLET

- Provides a direct branch connection at any location where a hole can be cut in the pipe
- A pressure responsive gasket provides the seal
- Request Publication 11.03 for Mechanical-T cross assemblies
- Pressure rated up to 500 psi/3450 kPa on steel pipe; also available for use with HDPE pipe
- Sizes from 2 × ½"/50 × 15 mm through 8 × 4"/200 × 100 mm

### IMPORTANT NOTES:

Style 920 and Style 920N housings cannot be mated to one another to achieve cross connections.

Size Run × Branch Nominal Size Inches mm	Style No. 920 or 920N	Max. Work Pressure@ psi kPa	Dimensions							Approx. Weight Each	
			Hole Diameter +0.13 -0.00 Inches mm	T** Inches mm	V ‡ # Thd. Inches mm	V ‡ Grv. Inches mm	W Inches mm	Y Inches mm	Z Inches mm	Female Thd. Lbs. kg	Grv. Lbs. kg
2 50 × ½ (a) □ 15	920N	500 3450	1.50 38.1	2.00 51	2.53 64	—	1.61 41	5.35 136	2.75 70	3.1 1.5	—
	920N	500 3450	1.50 38.1	1.97 50	2.53 64	—	1.61 41	5.35 136	2.75 70	3.1 1.5	—
	920N	500 3450	1.50 38.1	1.85 47	2.53 64	—	1.61 41	5.35 136	2.75 70	3.0 1.4	—
	920N	500 3450	1.75 44.5	2.05 52	2.75 70	3.00 76	1.61 41	5.35 136	3.00 76	3.5 1.7	3.2 1.5
	920N	500 3450	1.75 44.5	2.03 52	2.75 70	3.12 79	1.61 41	5.35 136	3.25 83	3.6 1.7	3.2 1.5
2½ 65 × ½ (a) § □ 15	920N	500 3450	1.50 38.1	2.21 56	2.74 70	—	1.82 46	5.64 143	2.75 70	3.0 1.4	—
	920N	500 3450	1.50 38.1	2.18 55	2.74 70	—	1.82 46	5.64 143	2.75 70	3.0 1.4	—
	920N	500 3450	1.50 38.1	2.06 52	2.74 70	—	1.82 46	5.64 143	2.75 70	2.9 1.4	—
	920N	500 3450	1.75 44.5	2.30 58	3.00 76	3.25 83	1.82 46	6.29 160	3.00 76	3.5 1.7	3.2 1.5
	920N	500 3450	2.00 50.8	2.28 58	3.00 76	3.25 83	1.82 46	6.26 159	3.25 83	3.6 1.7	3.3 1.6
76.1 × ½ (a) □ 15	920N	300 2065	1.50 38.1	2.22 56	2.75 70	—	2.25 57	6.46 164	3.18 81	3.9 1.8	—
	920N	300 2065	1.50 38.1	2.19 56	2.75 70	—	2.25 57	6.46 164	3.18 81	3.9 1.8	—
	920N	300 2065	1.50 38.1	2.07 53	2.75 70	—	2.25 57	6.46 164	3.18 81	3.8 1.7	—
	920N	500 3450	1.75 44.5	2.30 58	3.00 76	3.31 84	1.92 49	6.29 160	3.00 76	3.5 1.6	3.2 1.5
	920N	500 3450	2.00 50.8	2.28 58	3.00 76	3.31 84	1.92 49	6.29 160	3.25 83	3.5 1.6	3.3 1.5
3 80 × ½ (a) □ 15	920N	500 3450	1.50 38.1	2.52 64	3.05 78	—	2.28 58	6.15 156	2.75 70	3.4 1.6	—
	920N	500 3450	1.50 38.1	2.49 63	3.05 78	—	2.28 58	6.15 156	2.75 70	3.4 1.6	—
	920N	500 3450	1.50 38.1	2.38 61	3.06 78	—	2.28 58	6.15 156	2.75 70	3.3 1.6	—
	920N	500 3450	1.75 44.5	2.55 65	3.25 83	3.56 90	2.28 58	6.15 156	3.00 76	3.8 1.8	3.7 1.8
	920N	500 3450	2.00 50.8	2.78 71	3.50 89	3.56 90	2.28 58	6.15 156	3.25 83	4.1 1.9	3.8 1.8
	920N	500 3450	2.50 63.5	2.75 70	3.50 89	3.56 90	2.28 58	6.75 172	3.88 99	4.9 2.3	4.6 2.1
3½ 90 × 2 50	920N	500 3450	2.50 63.5	3.00 76	—	3.75 95	2.44 62	6.72 171	3.88 99	—	3.8 1.8

TABLE CONTINUED ON PG. 3

\*\* Center of run to engaged pipe end, female threaded outlet only (dimensions approximate).

† Available with grooved or female threaded outlet. Specify choice on order.

‡ Center of run to end of fitting.

# Female threaded outlets are available to NPT and BSPT specifications.

@ See page 7 for Fire Protection approvals and pressure ratings.

(a) British Standard female pipe threaded outlet is available as listed. Specify "BSPT" clearly on order.

(b) For 76.1 mm threaded outlet, specify 2½" BSPT clearly on order.

§ Vds approved for fire protection services

□ LPCB approved for fire protection services

∅ Approved for use in China by Tianjin Approvals Company.



# Mechanical-T<sup>®</sup> Bolted Branch Outlets

STYLES 920 AND 920N

## DIMENSIONS

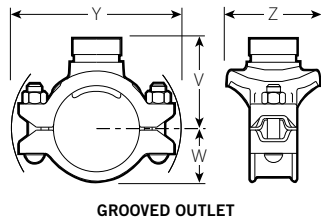

GROOVED OUTLET

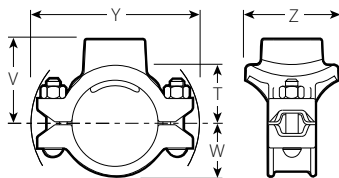

FEMALE THREADED OUTLET

- Provides a direct branch connection at any location where a hole can be cut in the pipe
- A pressure responsive gasket provides the seal
- Request Publication 11.03 for Mechanical-T cross assemblies
- Pressure rated up to 500 psi/3450 kPa on steel pipe; also available for use with HDPE pipe
- Sizes from 2 × ½"/50 × 15 mm through 8 × 4"/200 × 100 mm

### IMPORTANT NOTES:

Style 920 and Style 920N housings cannot be mated to one another to achieve cross connections.

Size	Style No.	Max. Work Pressure@	Dimensions							Approx. Weight Each		
			Run × Branch Nominal Size Inches mm	920 or 920N	psi kPa	Hole Diameter +0.13 -0.00	T** Inches mm	V † # Thd. Inches mm	V † Grv. Inches mm	W Inches mm	Y Inches mm	Z Inches mm
<b>TABLE CONTINUED FROM PAGE 2</b>												
4 100	½ (a) □	920N	500 3450	1.50 38.1	3.03 77	3.56 90	—	2.69 68	7.01 178	2.75 70	3.7 1.8	—
	¾ (a) □	920N	500 3450	1.50 38.1	3.00 76	3.56 90	—	2.69 68	7.01 178	2.75 70	3.7 1.8	—
	1 (a) □	920N	500 3450	1.50 38.1	2.88 73	3.56 90	—	2.69 68	7.01 178	2.75 70	3.6 1.8	—
	1 ¼ (a) † □		500 3450	1.75 44.5	3.08 78	3.78 96	4.00 102	2.69 68	7.01 178	3.00 76	4.0 1.9	3.6 1.8
	1 ½ (a) † □	920N	500 3450	2.00 50.8	3.28 83	4.00 102	4.00 102	2.69 68	7.01 178	3.25 83	4.2 2.0	3.9 1.9
	2 (a) † □	920N	500 3450	2.50 63.5	3.25 83	4.00 102	4.00 102	2.69 68	7.01 178	3.88 99	5.0 2.3	4.6 2.1
	2 ½ (a) †		500 3450	2.75 69.9	2.88 73	4.00 102	4.00 102	2.69 68	7.34 186	4.63 118	5.8 2.6	5.0 2.3
	76.1 mm	920	500 3450	2.75 69.9	2.88 73	—	4.00 102	2.69 68	7.34 186	4.63 118	—	6.4 2.9
	3 (a) †	920	500 3450	3.50 88.9	3.31 84	4.50 114	4.12 105	2.69 68	7.73 196	5.12 130	8.4 3.8	6.4 2.9
	76.1 mm		500 3450	3.50 88.9	3.31 84	4.50 114	4.50 114	2.69 67	7.73 194	5.12 124	8.4 3.8	6.4 3.0
108.0	1 ¼ (a) □	920N	500 3450	1.75 44.5	3.08 78	3.78 96	—	2.63 67	7.64 194	3.05 78	5.0 2.3	—
	1 ½ (a) □	920N	500 3450	2.00 50.8	3.28 83	4.00 102	—	2.63 67	7.64 194	3.25 83	5.0 2.3	—
	2 (a)	920N	500 3450	2.50 63.5	3.25 83	4.00 102	—	2.63 67	7.64 194	4.00 102	4.0 1.9	—
	76.1 mm		500 3450	2.75 69.9	2.88 73	4.00 102	4.00 102	2.63 67	7.64 194	4.29 109	8.0 3.6	7.8 3.5
	3 (a)	920	500 3450	3.50 88.9	3.31 84	4.50 114	4.50 114	2.63 67	7.63 194	4.88 124	6.8 3.1	6.5 3.0
	76.1 mm		500 3450	3.50 88.9	3.31 84	4.50 114	4.50 114	2.63 67	7.63 194	4.88 124	6.8 3.1	6.5 3.0
5 125	1 ½ (a) †	920	500 3450	2.00 50.8	4.03 102	4.75 121	4.75 121	3.16 80	9.70 246	3.69 94	7.4 3.4	7.6 3.4
	2 (a) †		500 3450	2.50 63.5	4.00 102	4.75 121	4.75 121	3.16 80	9.70 246	4.38 111	8.2 3.7	8.0 3.6
	2 ½ (a) †	920	500 3450	2.75 69.9	3.63 92	4.75 121	4.75 121	3.16 80	9.70 246	4.63 118	8.3 3.8	7.9 3.6
	76.1 mm □		500 3450	2.75 69.9	3.75 95	—	4.75 121	3.16 80	9.70 246	4.63 118	—	8.0 3.6
	3 (a) †	920	500 3450	3.50 88.9	3.81 97	5.00 127	4.63 118	3.16 80	9.70 246	5.31 135	8.4 3.8	8.8 4.0
	76.1 mm		500 3450	3.50 88.9	3.81 97	5.00 127	4.63 118	3.16 80	9.70 246	5.31 135	8.4 3.8	8.8 4.0
133.0	2 50	920N	500 3450	2.50 63.5	3.75 95	4.50 114	—	3.17 81	8.00 203	3.88 99	8.0 3.6	—
	3 80	920	500 3450	3.50 88.9	3.81 97	5.00 127	—	3.00 76	9.46 240	5.31 135	8.0 3.6	—
<b>TABLE CONTINUED ON PG. 4</b>												

\*\* Center of run to engaged pipe end, female threaded outlet only (dimensions approximate).

† Available with grooved or female threaded outlet. Specify choice on order.

‡ Center of run to end of fitting.

# Female threaded outlets are available to NPT and BSPT specifications.

@ See page 7 for Fire Protection approvals and pressure ratings.

(a) British Standard female pipe threaded outlet is available as listed. Specify "BSPT" clearly on order.

(b) For 76.1 mm threaded outlet, specify 2½" BSPT clearly on order.

§ Vds approved for fire protection services

□ LPCB approved for fire protection services

∅ Approved for use in China by Tianjin Approvals Company.



# Mechanical-T<sup>®</sup> Bolted Branch Outlets

STYLES 920 AND 920N

## DIMENSIONS

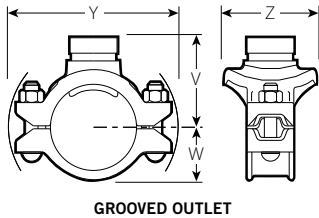

GROOVED OUTLET

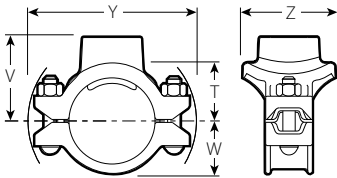

FEMALE THREADED OUTLET

- Provides a direct branch connection at any location where a hole can be cut in the pipe
- A pressure responsive gasket provides the seal
- Request Publication 11.03 for Mechanical-T cross assemblies
- Pressure rated up to 500 psi/3450 kPa on steel pipe; also available for use with HDPE pipe
- Sizes from 2 × 1/2"/50 × 15 mm through 8 × 4"/200 × 100 mm

### IMPORTANT NOTES:

Style 920 and Style 920N housings cannot be mated to one another to achieve cross connections.

Size Run × Branch Nominal Size Inches mm	Style No. 920 or 920N	Max. Work Pressure@ psi kPa	Dimensions							Approx. Weight Each		
			Hole Diameter +0.13 -0.00 Inches mm	T** Inches mm	V † # Thd. Inches mm	V † Grv. Inches mm	W Inches mm	Y Inches mm	Z Inches mm	Female Thd. Lbs. kg	Grv. Lbs. kg	
<b>TABLE CONTINUED FROM PAGE 3</b>												
139.7 ×	1 1/2 † 40	920N	500 3450	2.00 50.8	3.78 96	4.50 114	—	3.30 84	8.23 209	3.25 83	7.0 3.2	—
	2 † 50	920N	500 3450	2.50 63.5	3.75 95	4.50 114	—	3.30 84	8.23 209	3.88 99	9.0 4.1	—
6 150 ×	1 1/2 (a) 32 (b)	920N	500 3450	1.75 44.5	4.43 112	5.13 130	5.13 130	3.79 96	9.15 232	3.25 83	5.1 2.3	4.8 2.2
	1 1/2 (a) † 40 (b)	920N	500 3450	2.00 50.8	4.40 112	5.13 130	5.13 130	3.79 96	9.15 232	3.25 83	5.4 2.4	5.1 2.3
	2 (a) † 50	920N	500 3450	2.50 63.5	4.38 111	5.13 130	5.13 130	3.79 96	9.15 232	3.88 99	6.0 2.7	5.6 2.5
	2 1/2 65	920	500 3450	2.75 69.9	4.01 110	5.13 130	5.12 130	3.69 94	10.51 267	4.63 118	8.3 3.8	7.6 3.4
	76.1 mm <sup>‡</sup>	920	500 3450	2.75 69.9	4.15 105	—	5.21 132	3.69 94	10.51 267	4.63 118	—	8.4 3.8
	3 (a) † 80	920	500 3450	3.50 88.9	4.31 110	5.50 140	5.13 130	3.69 94	10.51 267	5.31 135	9.9 4.5	8.4 3.8
159.0 ×	4 (a) † 100	920	500 3450	4.50 114.3	3.81 97	5.75 146	5.38 137	3.69 94	10.51 267	6.25 159	10.1 4.6	10.1 4.6
	1 1/2 (a) 40	920N	500 3450	2.00 50.8	4.41 112	5.13 130	—	3.63 92	9.40 239	3.25 83	7.8 3.5	—
	2 (a) 50	920N	500 3450	2.50 63.5	4.38 111	5.13 130	—	3.63 92	9.40 239	3.88 99	8.0 3.6	—
	76.1 mm	920	500 3450	2.75 69.9	4.38 111	5.50 140	5.13 130	3.63 92	9.40 239	4.63 118	9.5 4.3	9.5 4.3
	3 80	920	500 3450	3.50 88.9	4.31 110	5.50 140	5.13 130	3.63 92	9.40 239	5.31 135	8.1 3.7	14.0 6.4
	108.0 mm	920	500 3450	4.50 114.3	4.45 113	—	5.38 137	3.63 92	9.40 239	6.12 155	—	10.0 4.5
<b>TABLE CONTINUED ON PG. 5</b>												

\*\* Center of run to engaged pipe end, female threaded outlet only (dimensions approximate).

† Available with grooved or female threaded outlet. Specify choice on order.

‡ Center of run to end of fitting.

# Female threaded outlets are available to NPT and BSPT specifications.

@ See page 7 for Fire Protection approvals and pressure ratings.

(a) British Standard female pipe threaded outlet is available as listed. Specify "BSPT" clearly on order.

(b) For 76.1 mm threaded outlet, specify 2 1/2" BSPT clearly on order.

§ Vds approved for fire protection services

‡ LPCB approved for fire protection services

Ø Approved for use in China by Tianjin Approvals Company.

# Mechanical-T<sup>®</sup> Bolted Branch Outlets

STYLES 920 AND 920N

## DIMENSIONS

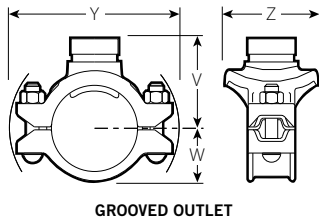

GROOVED OUTLET

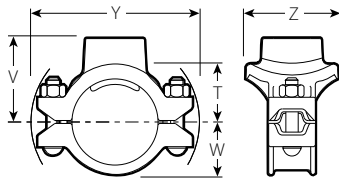

FEMALE THREADED OUTLET

- Provides a direct branch connection at any location where a hole can be cut in the pipe
- A pressure responsive gasket provides the seal
- Request Publication 11.03 for Mechanical-T cross assemblies
- Pressure rated up to 500 psi/3450 kPa on steel pipe; also available for use with HDPE pipe
- Sizes from 2 × 1/2"/50 × 15 mm through 8 × 4"/200 × 100 mm

Size Run × Branch Nominal Size Inches mm	Style No. 920 or 920N	Max. Work Pressure@ psi kPa	Dimensions							Approx. Weight Each		
			Hole Diameter +0.13 -0.00 Inches mm	T** Inches mm	V ‡ # Thd. Inches mm	V ‡ Grv. Inches mm	W Inches mm	Y Inches mm	Z Inches mm	Female Thd. Lbs. kg	Grv. Lbs. kg	
<b>TABLE CONTINUED FROM PAGE 4</b>												
165.1 ×	1 25	920N	500 3450	1.50 38.1	3.88 99	4.56 116	—	3.79 96	9.34 237	2.75 70	8.0 3.6	—
	1 1/4 (a) † 32	920N	500 3450	1.75 44.5	4.43 113	5.13 130	—	3.79 96	9.34 237	3.25 83	8.4 3.8	—
	1 1/2 (a) † ‡ 40	920N	500 3450	2.00 50.8	4.41 112	5.13 130	5.13 130	3.79 96	9.34 237	3.25 83	8.4 3.8	5.4 2.4
	2 (a) † 50	920N	500 3450	2.50 63.5	4.38 111	5.13 130	5.13 130	3.79 96	9.34 237	3.88 99	8.5 3.9	6.0 2.7
	76.1 mm	920	500 3450	2.75 69.9	4.01 110	5.13 130	5.21 132	3.63 92	10.51 267	4.63 118	8.6 3.9	7.6 3.4
	3 (a) † ∅ 80	920	500 3450	3.50 88.9	4.31 110	5.50 140	5.13 130	3.63 92	10.51 267	5.31 135	10.2 4.6	8.4 3.8
8 200 ×	4 (a) † ‡ 100	920	500 3450	4.50 114.3	3.81 97	5.75 146	5.38 137	3.63 92	10.51 267	6.25 159	10.5 4.8	8.4 3.8
	2 (a) † 50	920	500 3450	2.75 69.9	5.44 138	6.19 157	6.25 159	4.81 122	12.42 316	4.50 114	11.6 5.3	11.6 5.3
	2 1/2 (a) † 65	920	500 3450	2.75 69.9	5.07 129	6.19 157	6.19 157	4.81 122	12.42 316	4.50 114	11.6 5.3	11.6 5.3
	76.1 mm ‡	920	500 3450	2.75 69.9	5.25 133	—	6.25 159	4.81 122	12.42 316	4.56 116	—	11.6 5.3
	3 (a) † ‡ 80	920	500 3450	3.50 88.9	5.31 135	6.50 165	6.50 165	4.81 122	12.42 316	5.31 135	12.6 5.7	11.6 5.3
	4 (a) † ‡ 100	920	500 3450	4.50 114.3	4.81 122	6.75 171	6.38 162	4.81 122	12.42 316	6.25 159	15.3 6.9	12.5 5.7

\*\* Center of run to engaged pipe end, female threaded outlet only (dimensions approximate).

† Available with grooved or female threaded outlet. Specify choice on order.

‡ Center of run to end of fitting.

# Female threaded outlets are available to NPT and BSPT specifications.

@ See page 7 for Fire Protection approvals and pressure ratings.

(a) British Standard female pipe threaded outlet is available as listed. Specify "BSPT" clearly on order.

(b) For 76.1 mm threaded outlet, specify 2 1/2" BSPT clearly on order.

§ Vds approved for fire protection services

‡ LPCB approved for fire protection services

∅ Approved for use in China by Tianjin Approvals Company.

### IMPORTANT NOTES:

Style 920 and Style 920N housings cannot be mated to **each other** to achieve cross connections.

# Mechanical-T<sup>®</sup> Bolted Branch Outlets

STYLES 920 AND 920N

## FLOW DATA

Flow test data has shown that the total head loss between point (1) and (2) for the Style 920, 920N and 929 Mechanical-T<sup>®</sup> fittings can best be expressed in terms of the pressure difference across the inlet and branch. The pressure difference can be obtained from the relationship below.

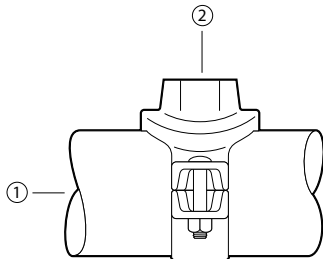

Exaggerated for clarity

### C<sub>v</sub> and K<sub>v</sub> Values

Values for flow of water at +60°F/+16°C are shown in the table below.

### Formulas for C<sub>v</sub>, K<sub>v</sub> Values:

$$\Delta P = \frac{Q^2}{C_v^2}$$

$$Q = C_v \times \sqrt{\Delta P}$$

### Where:

Q = Flow (GPM)

ΔP = Pressure Drop (psi)

C<sub>v</sub> = Flow Coefficient

$$\Delta P = \frac{Q^2}{K_v^2}$$

$$Q = K_v \times \sqrt{\Delta P}$$

### Where:

Q = Flow (m<sup>3</sup>/hr)

ΔP = Pressure Drop (Bar)

K<sub>v</sub> = Flow Coefficient

OUTLET SIZE		Equivalent Length of Outlet Size Schedule 40 Carbon Steel Pipe (per UL 213, Sec. 16) (C = 120)† FT		C <sub>v</sub> /K <sub>v</sub> Values	
NOMINAL DIAMETER In/mm	ACTUAL O.D. In/mm	GROOVED	THREADED	GROOVED	THREADED
½	0.840	-	2	-	11
15	21.3	-	-	-	9.4
¾	1.050	-	4	-	16
20	26.7	-	-	-	13.7
1	1.315	3**	8	-	21
25	33.7	-	-	-	1.8
1 ¼	1.660	5 ½	6	50	48
32	42.7	-	-	42.9	41.1
1 ½	1.900	11	11	53	53
40	48.3	-	-	45.4	45.4
2	2.375	9	10 ½	112	104
50	60.3	-	-	96	89.1
2 ½	2.875	20	12 ½	119	150
65	73.0	-	-	102	128.5
76.1 mm	3.000	16*	-	161	-
	76.1	-	-	138.1	-
3	3.500	14	15 ½	249	237
80	88.9	-	-	213.4	203.1
4	4.500	20	22	421	401
100	114.3	-	-	360.8	343.6

† Hazen-Williams coefficient of friction is 120.

\* Pipe with a wall thickness of 0.165in./4.2mm.

\*\* 1" FireLock<sup>™</sup> Innovative Groove System (IGS) outlet

# Mechanical-T<sup>®</sup> Bolted Branch Outlets

STYLES 920 AND 920N

## FIRE PROTECTION APPROVALS AND PRESSURE RATINGS

The information provided below is based on the latest listing and approval data at the time of publication. Listings/Approvals are subject to change and/or additions by the approvals agencies. Contact Victaulic for performance on other pipe and the latest listings and approvals.

Run Size		Outlet Size Inches/mm	Pipe Schedule	Approval Agency Rated Working Pressures – psi/kPa				Vds	
Nominal Size Inches/mm	Actual Outside Diameter Inches/mm			UL	ULC	FM	LPCB	(Style 920)	(Style 920N)
2 1/2 - 6 65 - 150	2.875 - 6.625 73.0 - 168.3	All	10, 40	400 2755	400 2755	400 2755	290 1999	232 1599	362 2496
2 1/2 - 4 65 - 100	2.875 - 4.500 73.0 - 114.3	All	DF	300 2065	300 2065	300 2065	290 1999	232 1599	362 2496
2 1/2 - 4 65 - 100	2.875 - 4.500 73.0 - 114.3	All	SF	300 2065	300 2065	300 2065	290 1999	232 1599	362 2496
6 150	6.625 168.3	3, 4	10	300 2065	300 2065	250 1724	290 1999	232 1599	362 2496
6 150	6.625 168.3	3,4	30, 40	300 2065	300 2065	300 2065	290 1999	232 1599	362 2496
8 200	8.625 219.1	2 1/2	10, 40	400 2755	—	—	—	145 1000	—
8 200	8.625 219.1	3,4	10	300 2065	—	250 1724	—	145 1000	—
8 200	8.625 219.1	3,4	30, 40	300 2065	—	300 2065	—	145 1000	—

NOTES:

- 10 refers to Listed/Approved Schedule 10 steel sprinkler pipe.
- 40 refers to Listed/Approved Schedule 40 steel sprinkler pipe.
- DF refers to Listed/Approved Dyna-Flow steel sprinkler pipe manufactured by American Tube Company.
- SF refers to Listed/Approved Super-Flo steel sprinkler pipe manufactured by Allied Tube and Conduit Corporation.

### VIC-TAP II HOLE CUTTING TOOL FOR 4 - 8"/100 - 200MM CARBON STEEL PIPE



The Vic-Tap II hole cutting tool is designed for use with the Style 931 Vic-Tap II Mechanical-T unit, which is a combination of the Style 920 Mechanical-T and Series 726 Vic-Ball Valve. The Vic-Tap II is capable of tapping into carbon steel pipe systems under pressures up to 500 psi/3450 kPa.

The Style 931 Vic-Tap II Mechanical-T unit is a full port ball valve which can be mounted on 4"/100mm, 5"/125mm, 6"/150mm and 8"/200mm diameter pipe. The Style 931 comes with a 2 1/2"/65mm grooved outlet.

The drill motor is an electric motor with ground fault circuit interrupter (GFCI) in accordance with safety codes.

For more information, refer to publication 24.01.

## Mechanical-T<sup>®</sup> Bolted Branch Outlets

STYLES 920 AND 920N

---

**INSTALLATION**

Reference should always be made to the I-100 Victaulic Field Installation Handbook for the product you are installing. Handbooks are included with each shipment of Victaulic products for complete installation and assembly data, and are available in PDF format on our website at [www.victaulic.com](http://www.victaulic.com).

---

**WARRANTY**

Refer to the Warranty section of the current Price List or contact Victaulic for details.

---

**NOTE**

This product shall be manufactured by Victaulic or to Victaulic specifications. All products to be installed in accordance with current Victaulic installation/assembly instructions. Victaulic reserves the right to change product specifications, designs and standard equipment without notice and without incurring obligations.

---

For complete contact information, visit [www.victaulic.com](http://www.victaulic.com)

11.02 1480 REV P UPDATED 07/2022

VICTAULIC IS A REGISTERED TRADEMARK OF VICTAULIC COMPANY. © 2022 VICTAULIC COMPANY. ALL RIGHTS RESERVED.

11.02\_L

