

DRAWING SYMBOLS

ABBREVIATIONS

VICINITY MAP

PROJECT DIRECTORY

SHEET INDEX

PRFO20240187

H

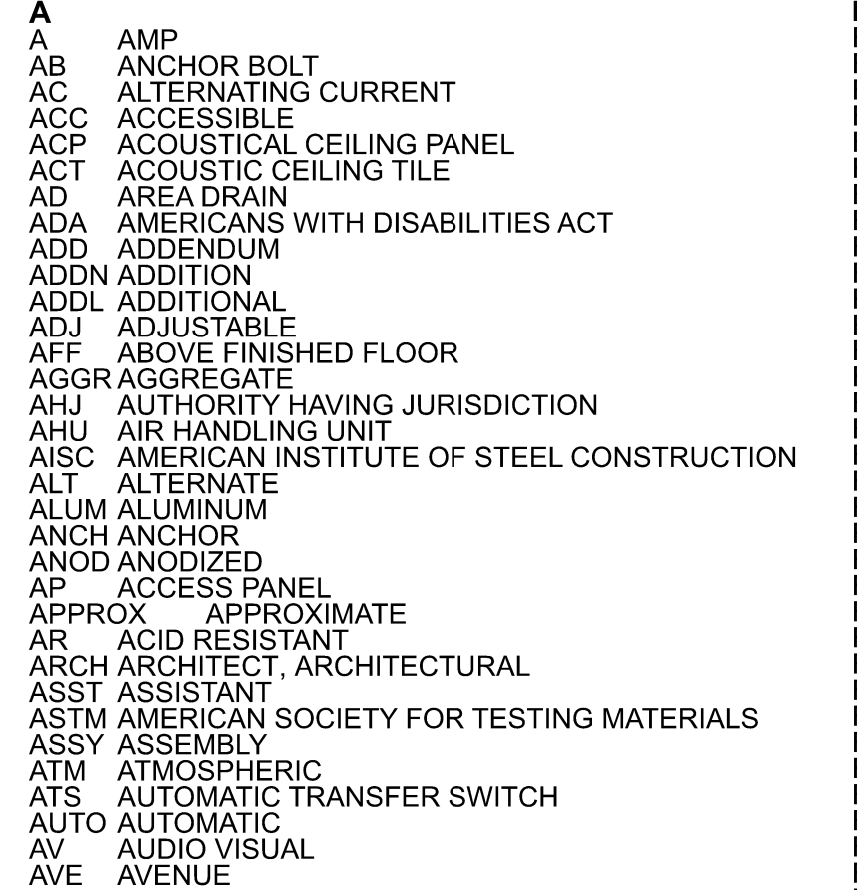
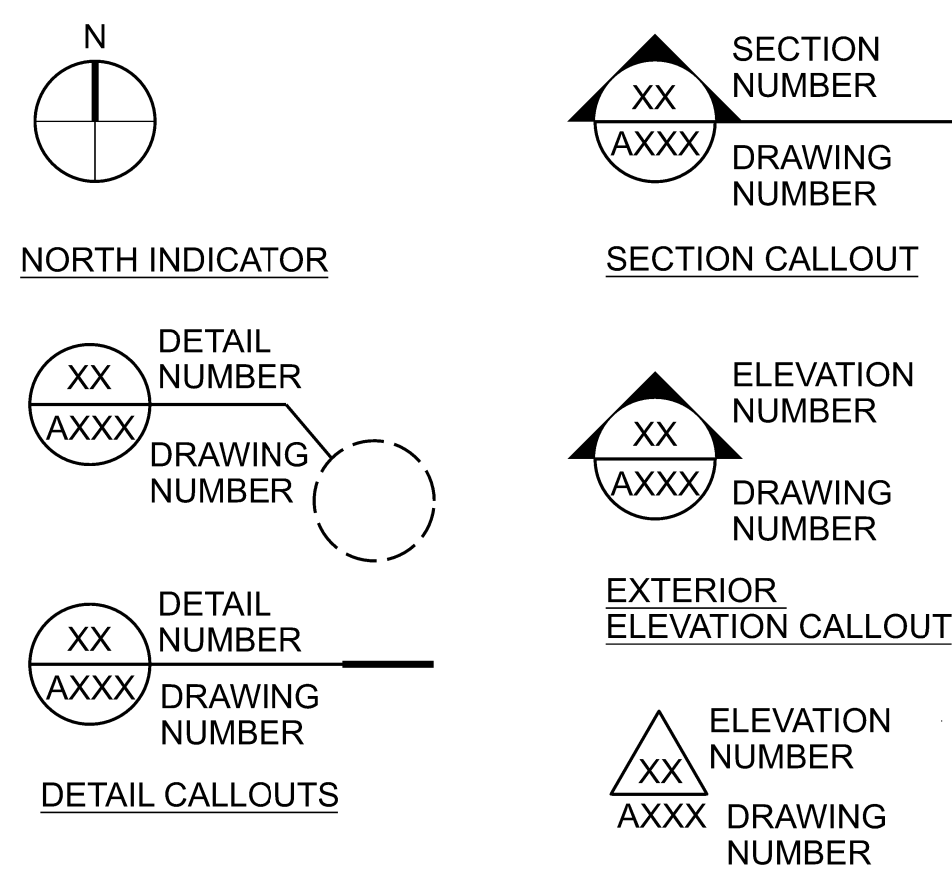

G

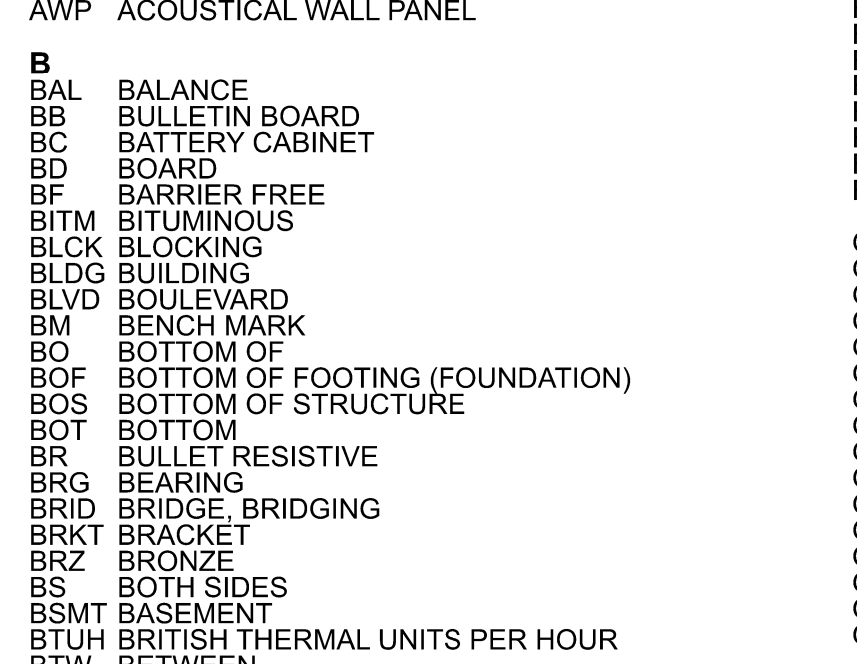
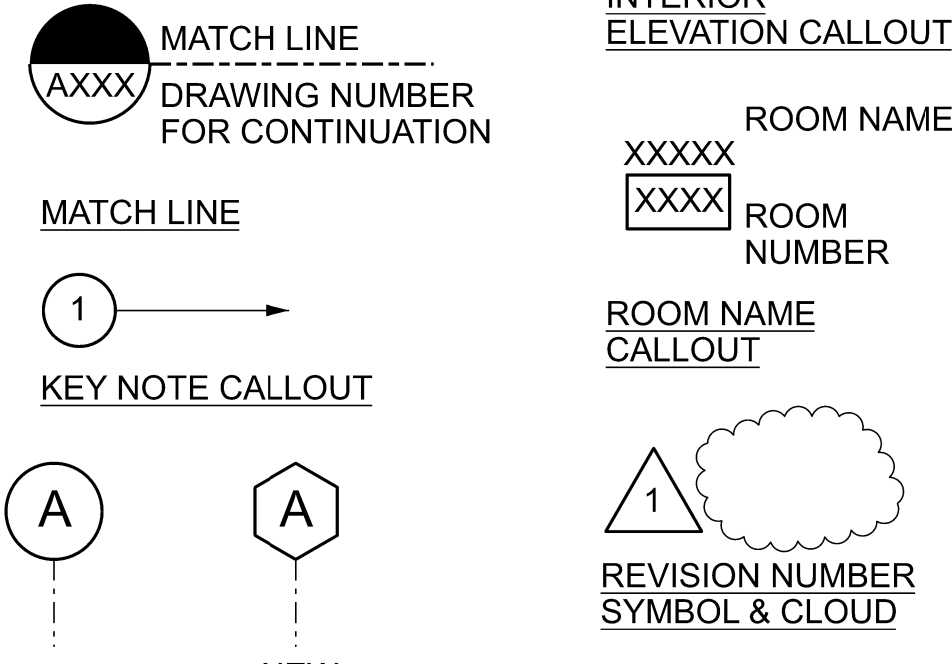

F

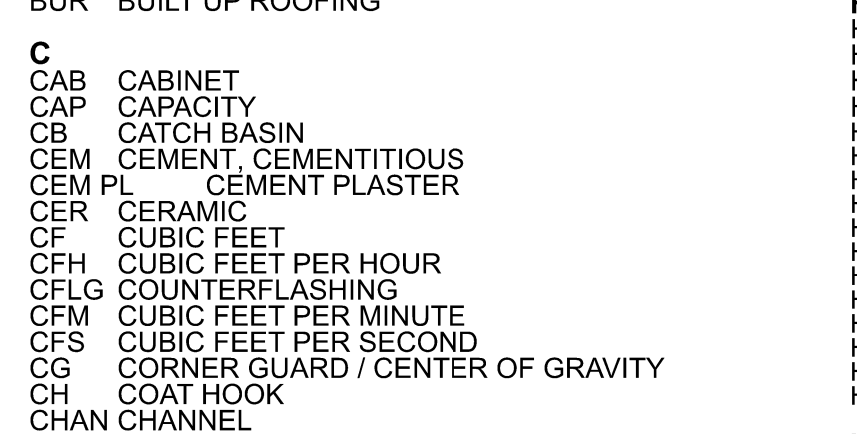
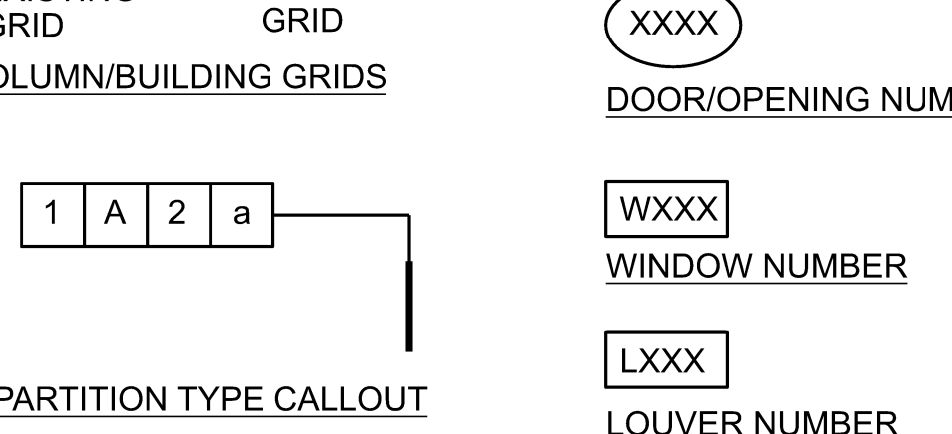

E

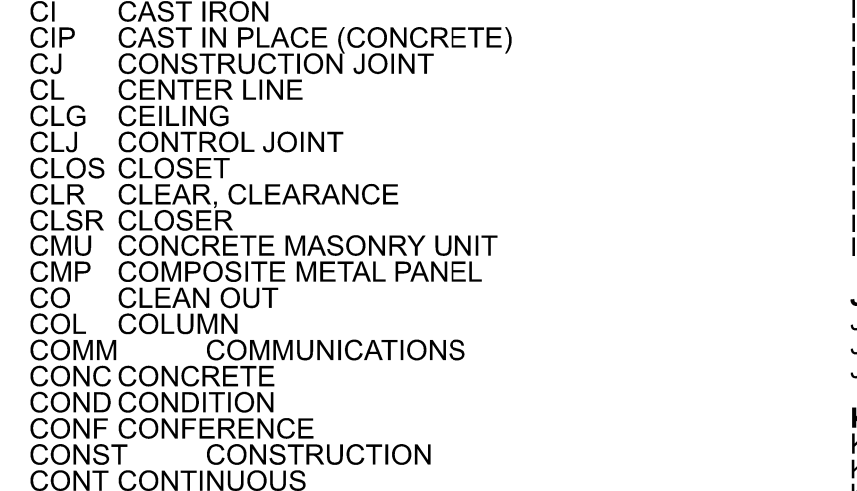
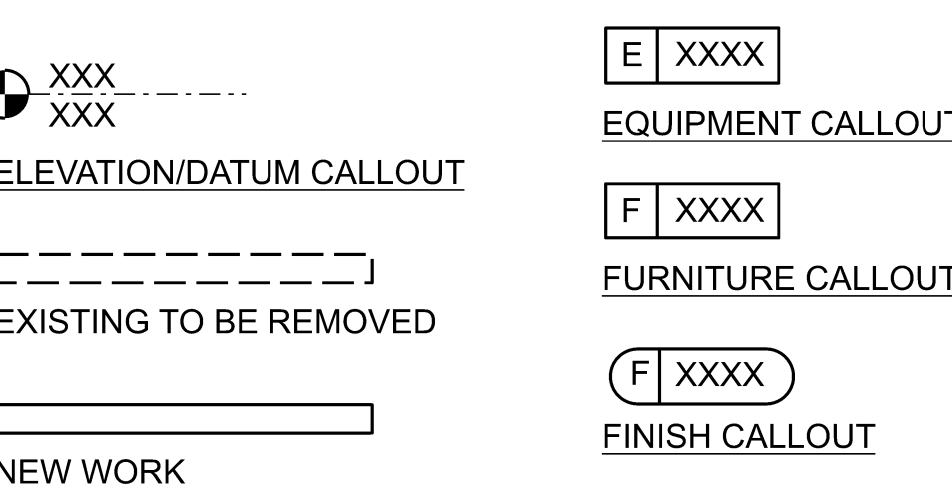

PLAN SYMBOLS

ABBREVIATIONS

D

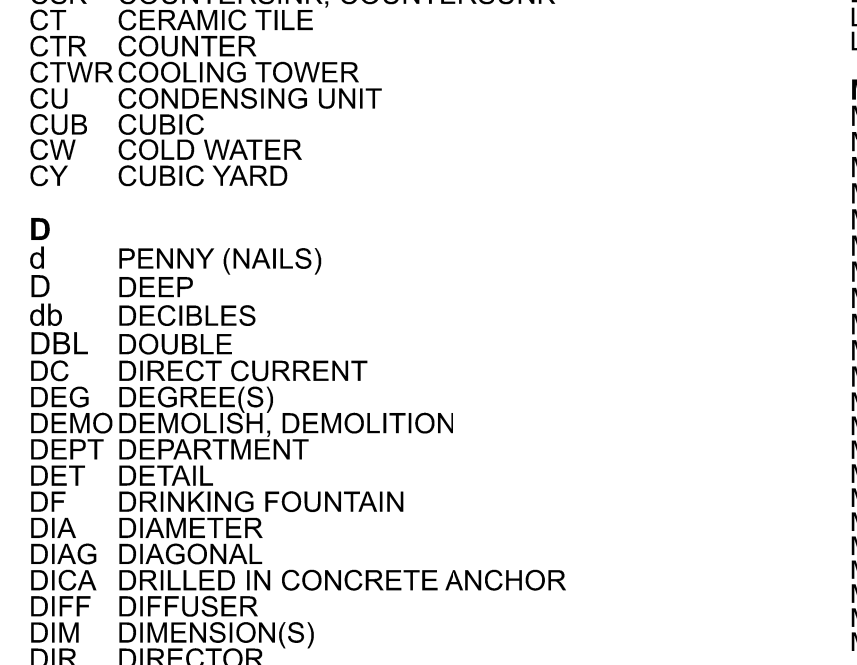
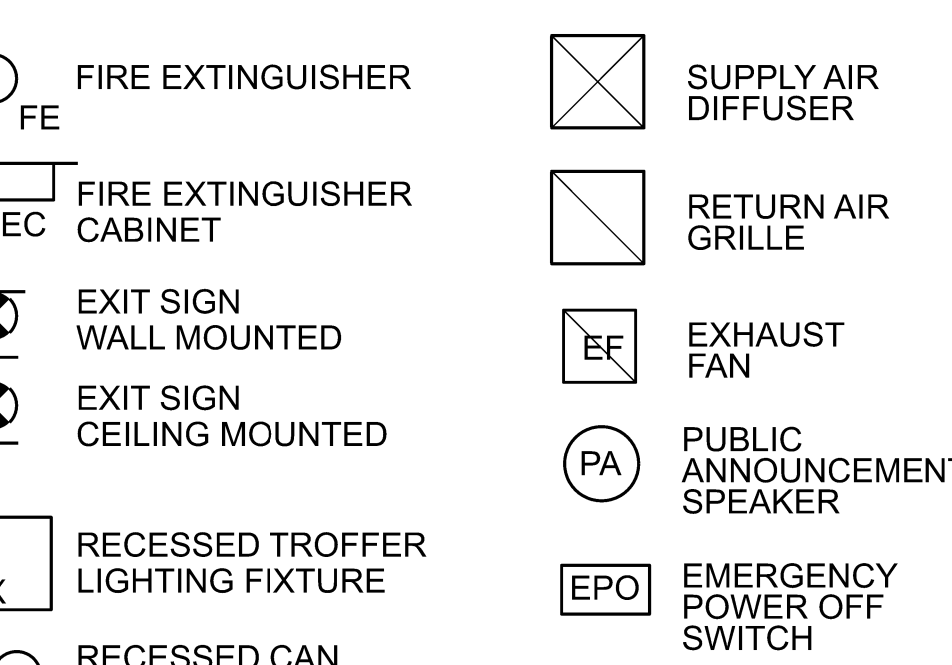

C

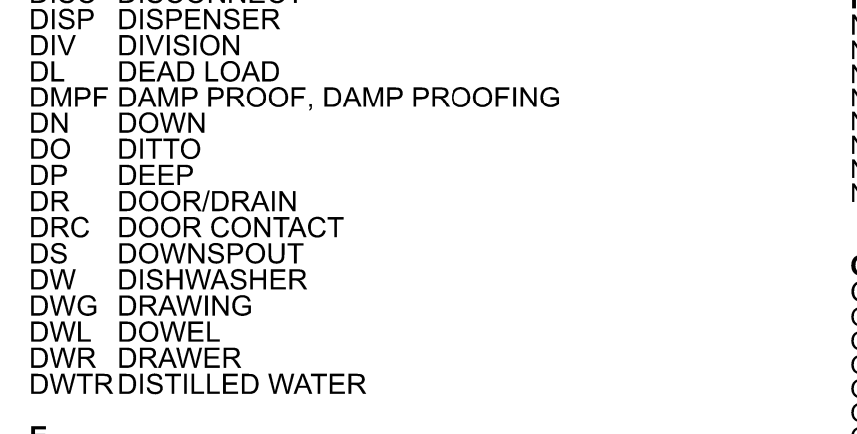
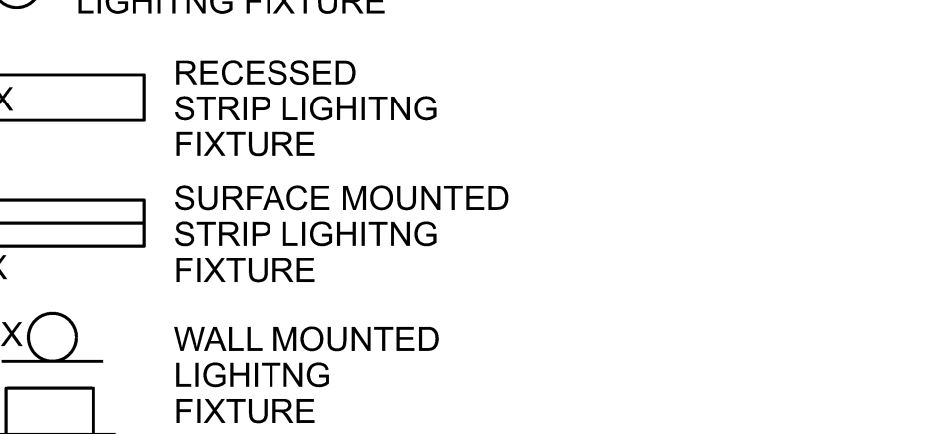

B

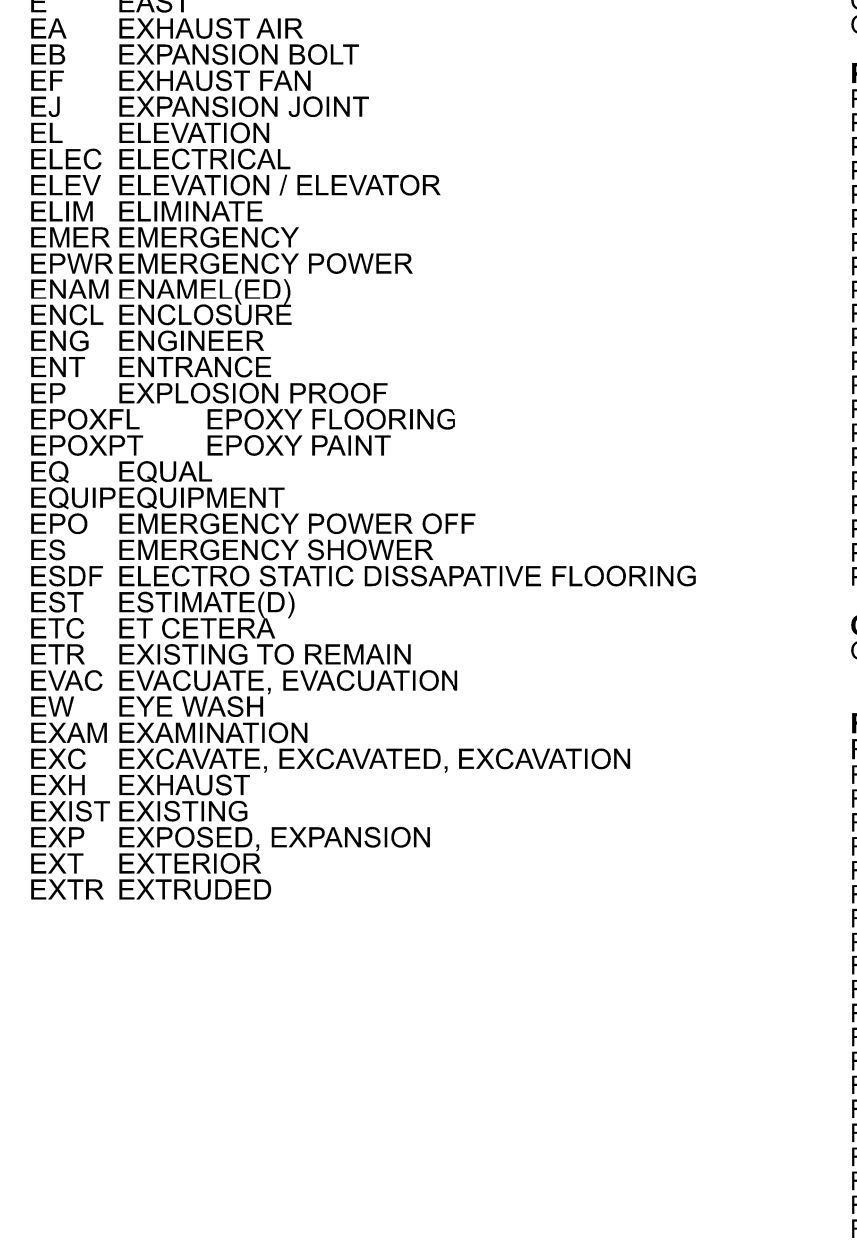
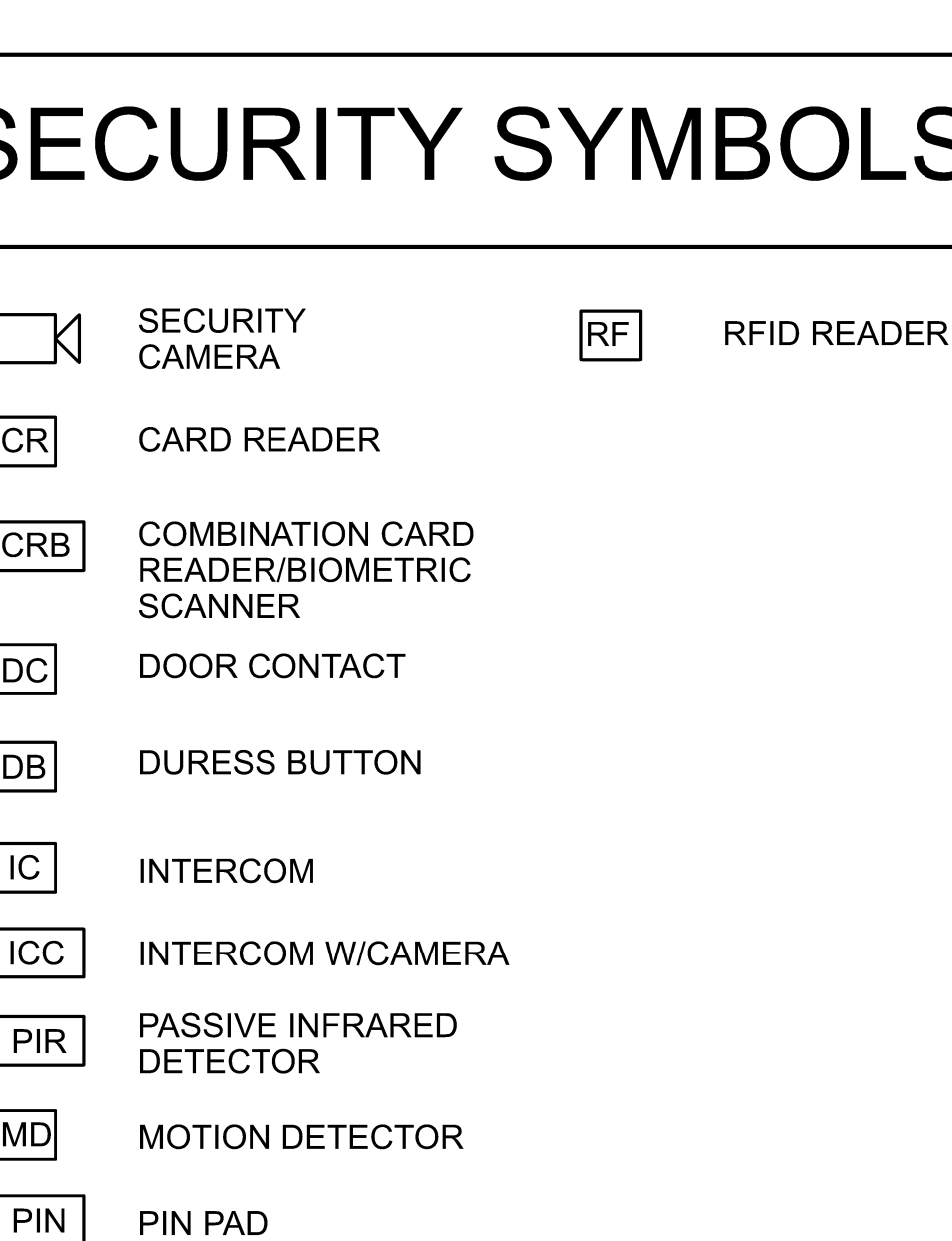

A

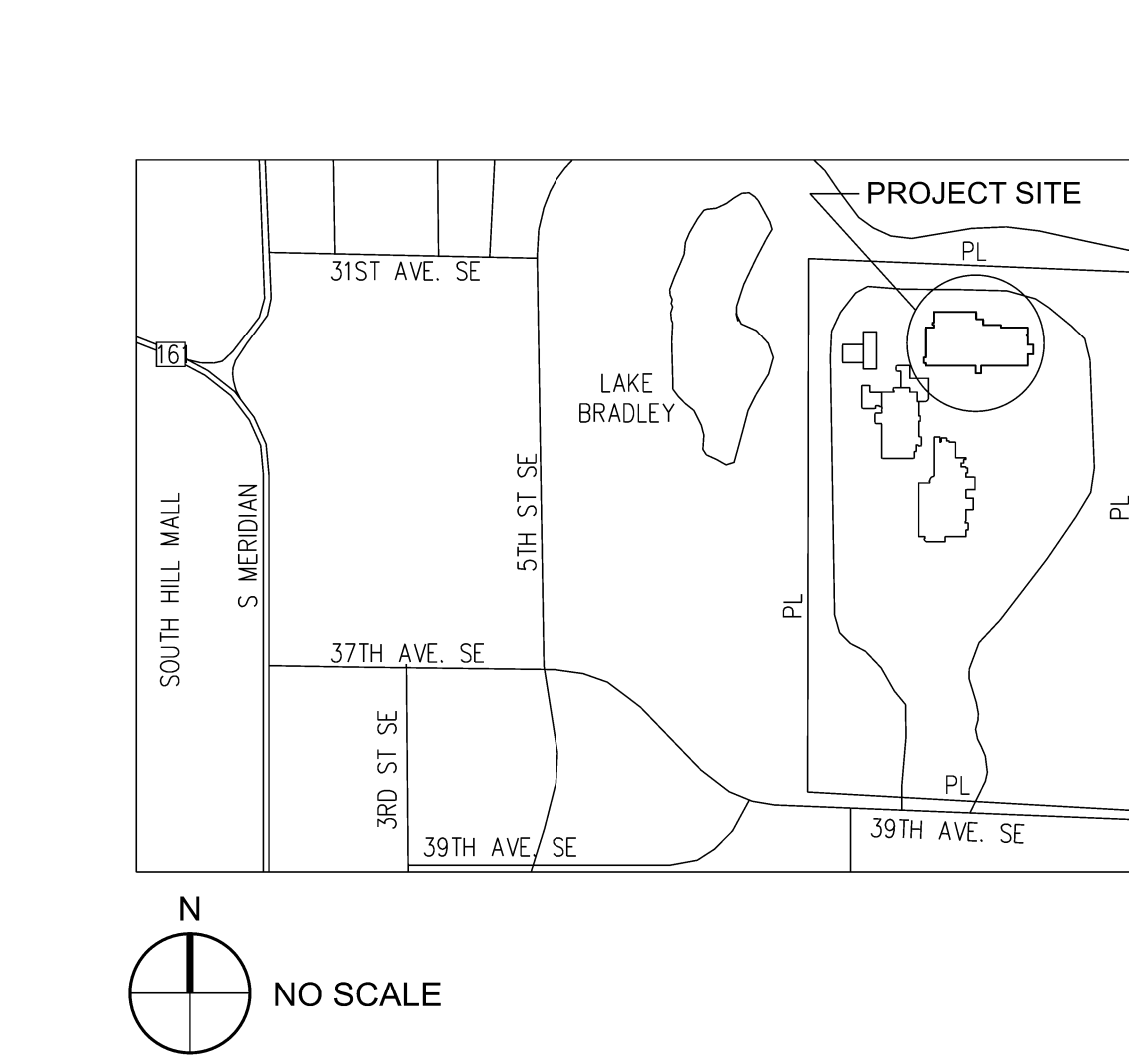

OWNER: BENAROYA CAPITAL, LLC
ARCHITECT: CASCADE MISSION CRITICAL, LLC
STRUCTURAL ENGINEER: QUANTUM CONSULTING ENGINEERS, LLC

PROJECT INFORMATION

SCOPE OF WORK

PROJECT ADDRESS: 1023 39TH AVENUE SE, PUYALLUP, WA 98374-2121
PARCEL NUMBER: 0419034037
LEGAL DESCRIPTION: SECTION 03 TOWNSHIP 19 RANGE 04 QUARTER 43 PARCEL "1" OF ROS 2007-04-30-5001

WORK UNDER THIS PERMIT: CONSTRUCT CONCRETE PAD FOUNDATIONS FOR 8 NEW STANDBY DIESEL GENERATORS AND EXTERIOR ELECTRICAL EQUIPMENT.
TOTAL AREA OF NEW CONCRETE PADS AND SLAB ON GRADE = 12,354 SF.
TOTAL AREA OF WORK = 17,526 SF.

CODE INFORMATION

GENERAL NOTES

APPLICABLE CODES: WASHINGTON BUILDING CODE, 2018 EDITION; WASHINGTON FIRE CODE, 2018 EDITION; WASHINGTON MECHANICAL CODE, 2018 EDITION; WASHINGTON PLUMBING CODE, 2018 EDITION; NATIONAL ELECTRIC CODE, CURRENT EDITION; WASHINGTON STATE ENERGY CODE, CURRENT EDITION.
LAND USE CODES: PUYALLUP MUNICIPAL CODE; EXISTING ZONING DESIGNATION: MP - BUSINESS PARK; PROPOSED ZONING DESIGNATION: MP - BUSINESS PARK; CHANGE OF USE REQUIRED: NO.
BUILDING CODE INFORMATION: BUILDING OCCUPANCY GROUP: TYPE B, DATA CENTER; TYPE OF CONSTRUCTION: TYPE IIA, FULLY SPRINKLERED; NO CHANGE TO BUILDING HEIGHT OR AREA.
LAND USE CODE INFORMATION: EXISTING SITE AREA: 15.77ACRES.

- 1. DO NOT SCALE THE DRAWINGS.
2. THE DRAWINGS AND SPECIFICATIONS ARE COMPLEMENTARY. WHAT IS SHOWN ON ONE SHALL BE CONSTRUED TO BE REQUIRED BY BOTH.
3. THE CONTRACTOR SHALL VERIFY ALL FIELD CONDITIONS PRIOR TO COMMENCING ANY WORK. NOTIFY THE ARCHITECT IMMEDIATELY IF ANY CONDITIONS IMPACT THE IMPLEMENTATION OF THE DESIGN INTENT. ALL EXISTING ELEMENTS SHOWN ON THE DRAWINGS ARE INCLUDED WITHOUT ANY GUARANTEE OF ACCURACY.
4. ALL DIMENSIONS ARE SHOWN TO THE STRUCTURAL GRID OR FINISHED SURFACES, UNLESS NOTED OTHERWISE.
5. DETAILS ARE SHOWN ON THE DRAWINGS FOR THE FIRST OCCURRENCE OF THE CONDITION AND ARE TYPICAL FOR ALL OTHER SIMILAR CONDITIONS.
6. PROVIDE A MINIMUM OF 6" FROM AN ADJACENT FINISHED SURFACE TO THE EDGE OF ANY FINISHED OPENING.

ARCHITECTURAL: A-000-05 GENERAL INFORMATION; A-101-05 OVERALL SITE PLAN; A-102-05 ENLARGED SITE PLAN; A-103-05 ENLARGED SITE PLANS; A-301-05 NORTH UTILITY YARD; A-302-05 SITE SECTIONS; NORTH UTILITY YARD; SITE SECTIONS; NORTH UTILITY YARD

OWNER: BENAROYA CAPITAL, LLC
Centeris Data Centers
9675 SE 36th St, Suite 1.15
Mercer Island, WA 98040
+1.253.200.4120

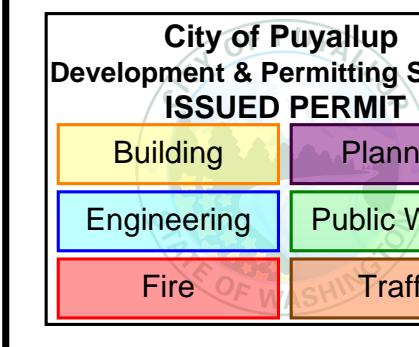

CONSULTANT: CASCADE MISSION CRITICAL, LLC
Data Center Consulting and Design
Puyallup, WA 98374-2121
P: 206-294-1288 www.cascademissioncritical.com

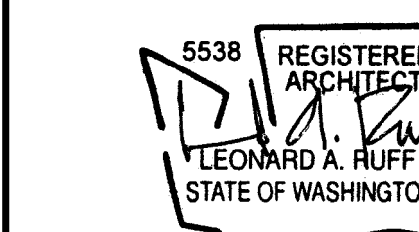

CASCADE MISSION CRITICAL, LLC
Data Center Consulting and Design
Puyallup, WA 98374-2121
P: 206-294-1288 www.cascademissioncritical.com

CENTERIS VOLTAGE PARK
1023 39th Avenue South East
Puyallup, WA 98374-2121
WB02-NORTH UTILITY YARD
GENERATOR & ELECTRICAL EQUIPMENT FOUNDATIONS & PADS

City of Puyallup Building Reviewed FOR COMPLIANCE
BSnowden
02/16/2024
8:12:24 AM

Approval for Foundation only. Other items must be approved via separate permit submittal.

The City shall not be held liable for any conflicts that arise between the approved building plans and approved civil construction plans since the building permits were issued prior to civil approval.

Call before you dig. It's the law. Dial 811 or call 1-800-424-5555.

Refer to the City standard details 02.03.02 & 05.02.01 for typical erosion and sedimentation control methods.

The approved construction plans, documents, and all engineering must be posted on the job at all inspections in a visible and readily accessible location.

Full sized legible color plans are required to be provided by the permittee on site for inspection.

Approval of submittal plans is not an approval of omissions or oversights by this office or non compliance with any applicable regulations of local government. The contractor is responsible for making sure that the building complies with all applicable codes and regulations of the local government.

ISSUED/REVISED DATE
PERMIT SUBMITTAL 2/5/24

PERMIT SUBMITTAL FEBRUARY 5, 2024

GENERAL NOTES

A-000-05

SITE INFORMATION

PARCEL NO. 0419034037
 ADDRESS: 1023 39TH AVENUE S.E.
 PARCEL AREA: 15.77 ACRES

LEGAL DESCRIPTION
 Section 03 Township 19 Range 04 Quarter 42 LOT 2 OF BLR 2022-03-22-5003 A POR OF BLR 2019-05-22-5002 LY IN CY OF PUYALLUP MORE PARTICULARLY DESC AS FOLL COM AT STONE MON MARKING S 1/4 COR OF SEC 3 SD STONE MON LIES N 86 DEG 31 MIN 42 SEC E 2621.06 FT FROM SE COR OF SD SEC 3 TH N 00 DEG 00 MIN 24 SEC E 2599.51 FT TH S 87 DEG 44 MIN 17 SEC E 496.53 FT TO POB TH S 00 DEG 04 MIN W 132.96 FT TH S 16 DEG 29 MIN 57 SEC E 15.96 FT TH S 00 DEG 00 MIN 36 SEC E 335.82 FT TH S 52 DEG 49 MIN 01 SEC E 132.81 FT TH S 89 DEG 15 MIN 41 SEC E 28.82 FT TH S 82 DEG 14 MIN 13 SEC E 58.63 FT TH S 53 DEG 48 MIN 38 SEC E 78.9 FT TH S 89 DEG 41 MIN 48 SEC E 655.79 FT TH S 83 DEG 08 MIN 36 SEC E 199.54 FT TH N 00 DEG 13 MIN 45 SEC E 602.4 FT TH N 87 DEG 44 MIN 17 SEC W 1118.01 FT TO POB EASE OF REC. OUT OF 04-19-03-4-031 & 4-034 SEG 2019-0472 05/30/19 JP 20190652DC 03/31/22 JP

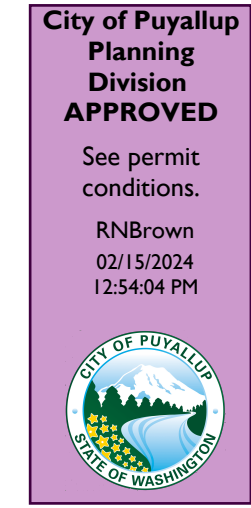

Planning Note: Foundation only permit, no other structures approved under this permit.

OVERALL SCOPE OF WORK

NORTH UTILITY YARD (PARCEL 0419034037)
 REMOVE 2 EXISTING DIESEL GENERATORS
 INSTALL CONCRETE PADS & FOUNDATIONS FOR 8 NEW DIESEL GENERATORS
 INSTALL CONCRETE PADS FOR NEW MV SWITCHES
 INSTALL CONCRETE PADS FOR 8 NEW PAD MOUNTED TRANSFORMERS
 INSTALL CONCRETE PADS AND FOUNDATIONS FOR 8 NEW SETS OF EXTERIOR SWITCHGEAR

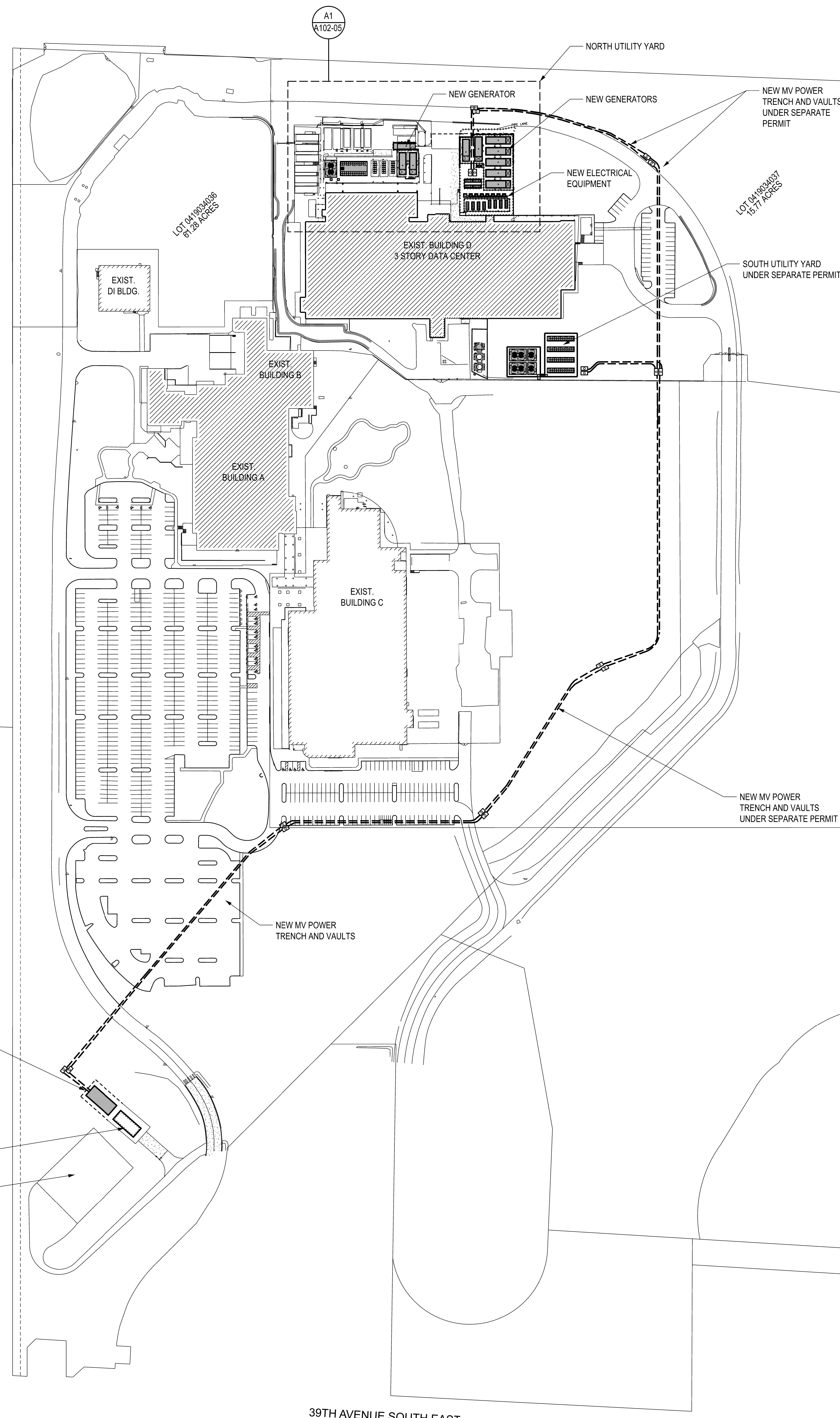

A6 OVERALL SITE PLAN
 SCALE: 1" = 100'

PRFO20240187

OWNER:
 BENAROYA CAPITAL, LLC
 Centeris Data Centers
 9675 SE 36th St, Suite 115
 Mercer Island, WA 98040
 +1.253.200.4120

City of Puyallup
 Development & Permitting Services
ISSUED PERMIT

| | |
|-------------|--------------|
| Building | Planning |
| Engineering | Public Works |
| Fire | Traffic |

CONSULTANT:

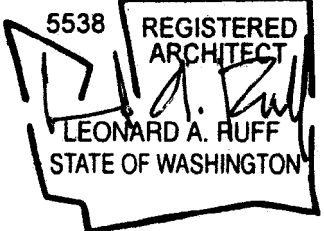

CASCADE MISSION CRITICAL, LLC
 Data Center Consulting and Design
 6210 36th Avenue N.E. Seattle, WA 98115
 P: 206-294-1288 www.cascadecommissioncritical.com

CENTERIS VOLTAGE PARK
 1023 39th Avenue South East
 Puyallup, WA 98374-2121
 WB02-NORTH UTILITY YARD
 GENERATOR & ELECTRICAL EQUIPMENT
 FOUNDATIONS & PADS

| ISSUED/REVISED | DATE |
|------------------|--------|
| PERMIT SUBMITTAL | 2/5/24 |

PERMIT SUBMITTAL
 FEBRUARY 5, 2024
 OVERALL SITE PLAN

A-101-05

OWNER:
BENAROYA CAPITAL, LLC
Centeris Data Centers
9675 SE 36th St, Suite 115
Mercer Island, WA 98040
+1.253.200.4120

City of Puyallup
Development & Permitting Services
ISSUED PERMIT

| | |
|-------------|--------------|
| Building | Planning |
| Engineering | Public Works |
| Fire | Traffic |

CONSULTANT:

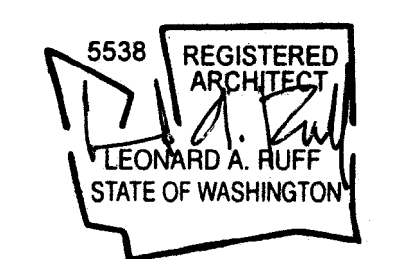

CASCADE MISSION CRITICAL, LLC
Data Center Consulting and Design
6210 36th Avenue N.E., Seattle, WA 98115
P: 206-294-1288 www.cascadecritical.com

CENTERIS VOLTAGE PARK
1023 39th Avenue South East
Puyallup, WA 98374-2121
WB02-NORTH UTILITY YARD
GENERATOR & ELECTRICAL EQUIPMENT
FOUNDATIONS & PADS

| ISSUED/REVISED | DATE |
|------------------|--------|
| PERMIT SUBMITTAL | 2/5/24 |

PERMIT SUBMITTAL
FEBRUARY 5, 2024

ENLARGED SITE PLAN
NORTH UTILITY YARD

A-102-05

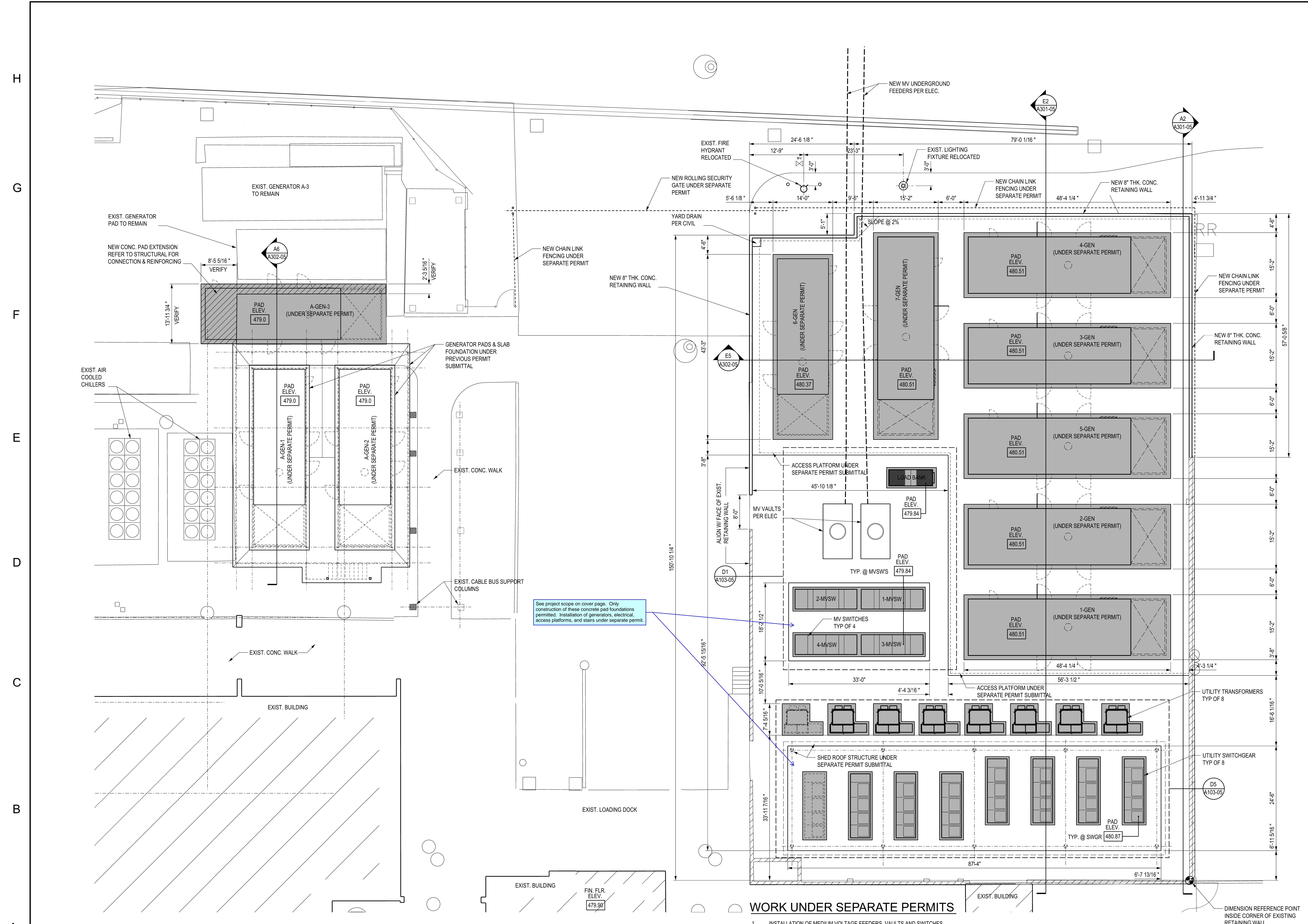

WORK UNDER SEPARATE PERMITS

1. INSTALLATION OF MEDIUM VOLTAGE FEEDERS, VAULTS AND SWITCHES.
2. INSTALLATION OF UTILITY TRANSFORMERS.
3. INSTALLATION OF DIESEL STANDBY GENERATORS.
4. INSTALLATION OF ELECTRICAL SWITCHGEAR.
5. INSTALLATION OF ELECTRICAL LOAD BANK.
6. CONSTRUCTION OF NEW SHED ROOF OVER ELECTRICAL SWITCHGEAR.
7. NEW CHAINLINK FENCING AND ROLLING SECURITY GATE.
8. INSTALLATION OF GENERATOR ACCESS PLATFORMS AND STAIRS.

A1 ENLARGED SITE PLAN - NORTH UTILITY YARD
SCALE: 1" = 20'-0"

OWNER:
BENAROYA CAPITAL, LLC
Centeris Data Centers
9675 SE 36th St, Suite 115
Mercer Island, WA 98040
+1.253.200.4120

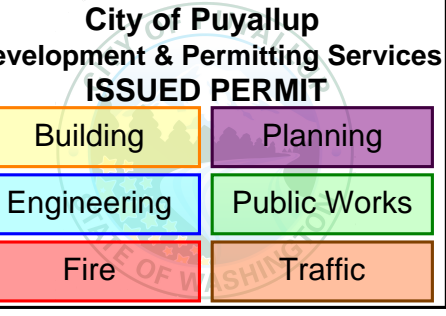

CONSULTANT:

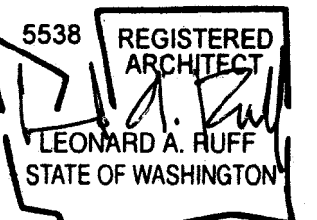

CASCADE MISSION CRITICAL, LLC
Data Center Consulting and Design
6210 36th Avenue N.E., Seattle, WA 98115
P: 206-294-1288 www.cascadecritical.com



CENTERIS VOLTAGE PARK
1023 39th Avenue South East
Puyallup, WA 98374-2121
WB02-NORTH UTILITY YARD
GENERATOR & ELECTRICAL EQUIPMENT
FOUNDATIONS & PADS

| ISSUED/REVISED | DATE |
|------------------|--------|
| PERMIT SUBMITTAL | 2/5/24 |

PERMIT SUBMITTAL
FEBRUARY 5, 2024

ENLARGED SITE PLANS
MV SWITCH AREA
TRANSFORMER & UTILITY SWITCHGEAR AREA

A-103-05

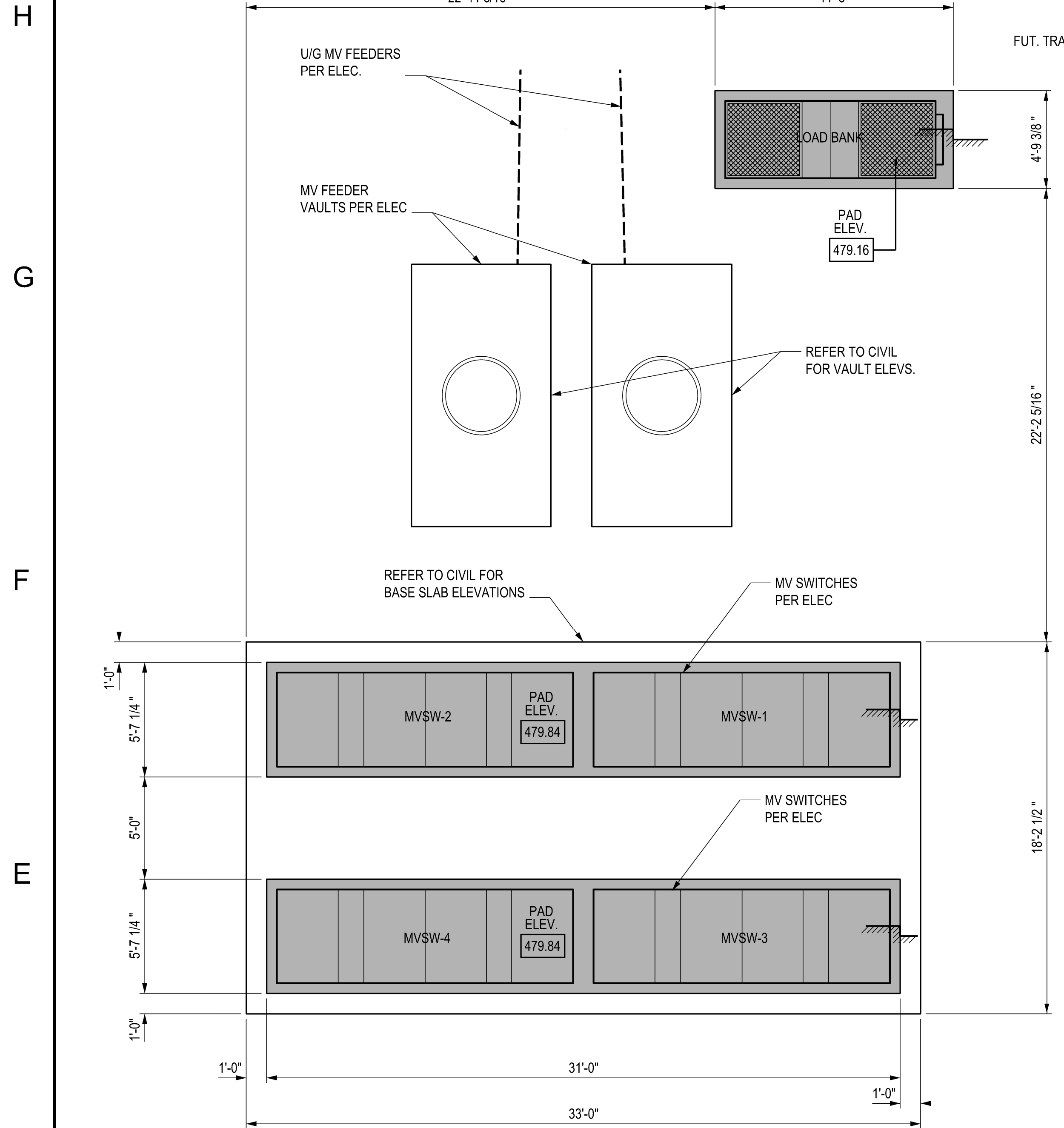

D1 ENLARGED SITE PLAN - MV SWITCH AREA
SCALE: 1/4" = 1'-0"

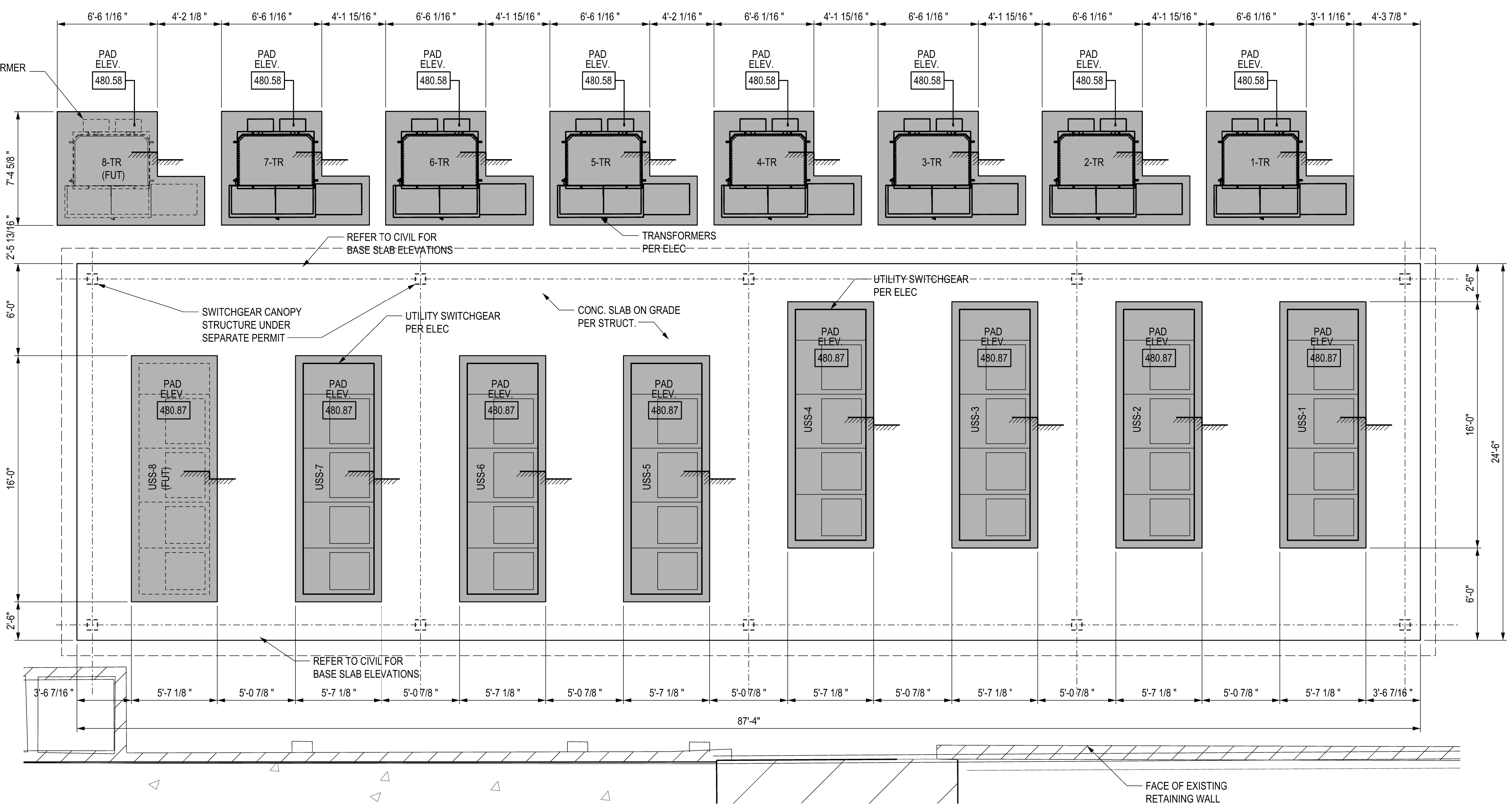

D5 ENLARGED SITE PLAN - TRANSFORMER & UTILITY SWITCHGEAR AREA
SCALE: 1/4" = 1'-0"

H
G
F
E
D
C
B
A

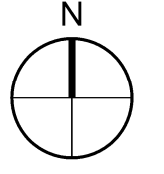
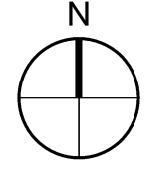

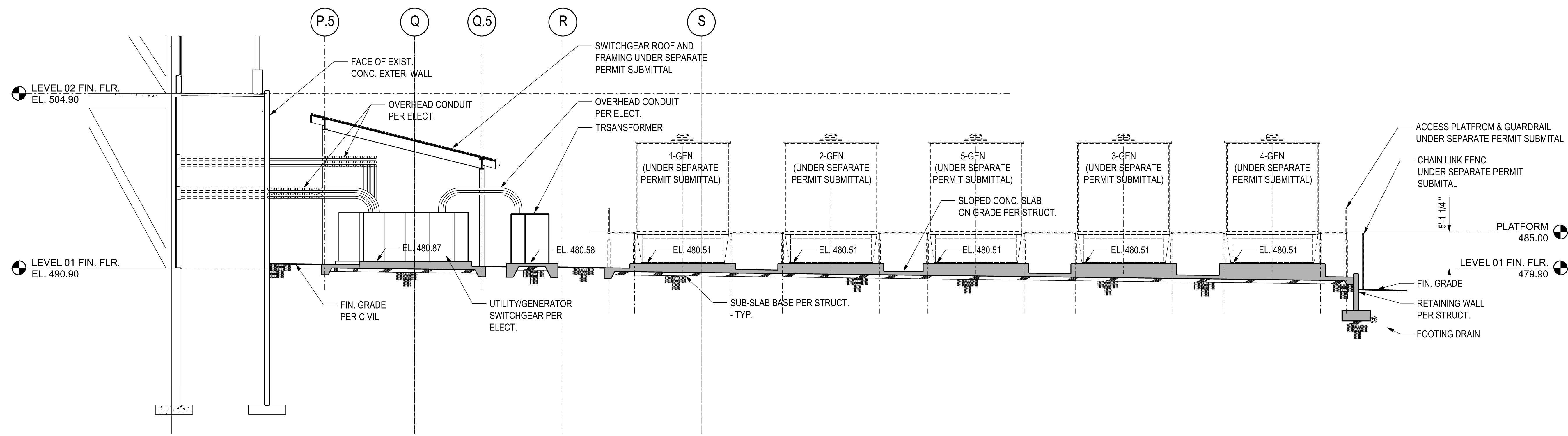

E2 SITE SECTION - GENERATOR PADS - NORTH TO SOUTH - LOOKING WEST
SCALE: 1/8" = 1'-0"

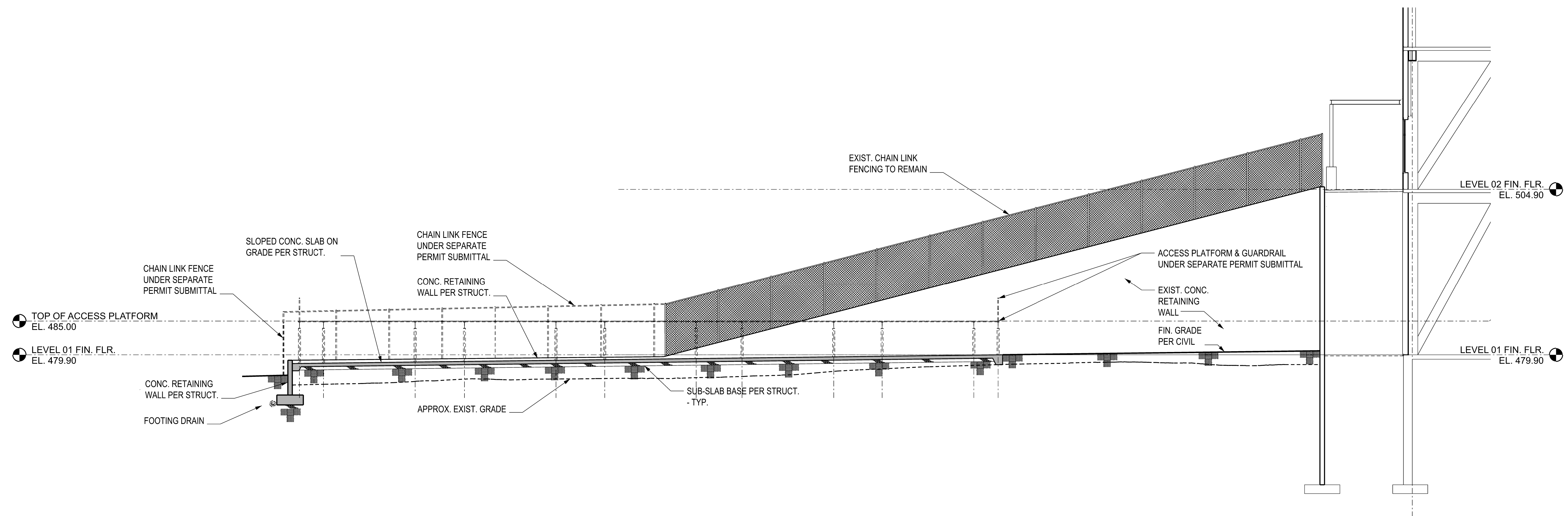

A2 SITE SECTION - GENERATOR PADS - NORTH TO SOUTH - LOOKING EAST
SCALE: 1/8" = 1'-0"

PRFO20240187

OWNER:
BENAROYA CAPITAL, LLC
Centeris Data Centers
9675 SE 36th St, Suite 115
Mercer Island, WA 98040
+1.253.200.4120

City of Puyallup
Development & Permitting Services
ISSUED PERMIT

| | |
|-------------|--------------|
| Building | Planning |
| Engineering | Public Works |
| Fire | Traffic |

CONSULTANT:

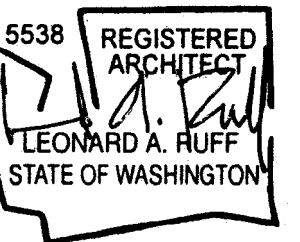

CASCADE MISSION CRITICAL, LLC
Data Center Consulting and Design
6210 36th Avenue N.E. Seattle, WA 98115
P: 206-294-1288 www.cascadecommissioncritical.com



CENTERIS VOLTAGE PARK
1023 39th Avenue South East
Puyallup, WA 98374-2121
WB02-NORTH UTILITY YARD
GENERATOR & ELECTRICAL EQUIPMENT
FOUNDATIONS & PADS

| ISSUED/REVISED | DATE |
|------------------|--------|
| PERMIT SUBMITTAL | 2/5/24 |

PERMIT SUBMITTAL
FEBRUARY 5, 2024
SITE SECTIONS
NORTH UTILITY YARD

A-301-05

OWNER:
BENAROYA CAPITAL, LLC
Centeris Data Centers
9675 SE 36th St, Suite 115
Mercer Island, WA 98040
+1.253.200.4120

City of Puyallup
Development & Permitting Services
ISSUED PERMIT

| | |
|-------------|--------------|
| Building | Planning |
| Engineering | Public Works |
| Fire | Traffic |

CONSULTANT:

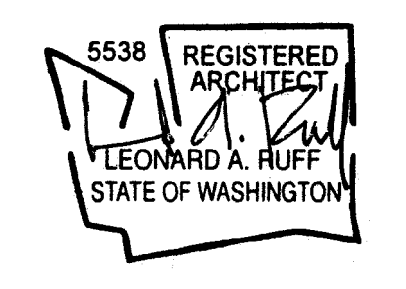

CASCADE MISSION CRITICAL, LLC
Data Center Consulting and Design
6210 36th Avenue N.E. Seattle, WA 98115
P: 206-294-1288 www.cascadecommissioncritical.com

CENTERIS VOLTAGE PARK
1023 39th Avenue South East
Puyallup, WA 98374-2121
WB02-NORTH UTILITY YARD
GENERATOR & ELECTRICAL EQUIPMENT
FOUNDATIONS & PADS

| ISSUED/REVISED | DATE |
|------------------|--------|
| PERMIT SUBMITTAL | 2/5/24 |

PERMIT SUBMITTAL
FEBRUARY 5, 2024
SITE SECTIONS
NORTH UTILITY YARD

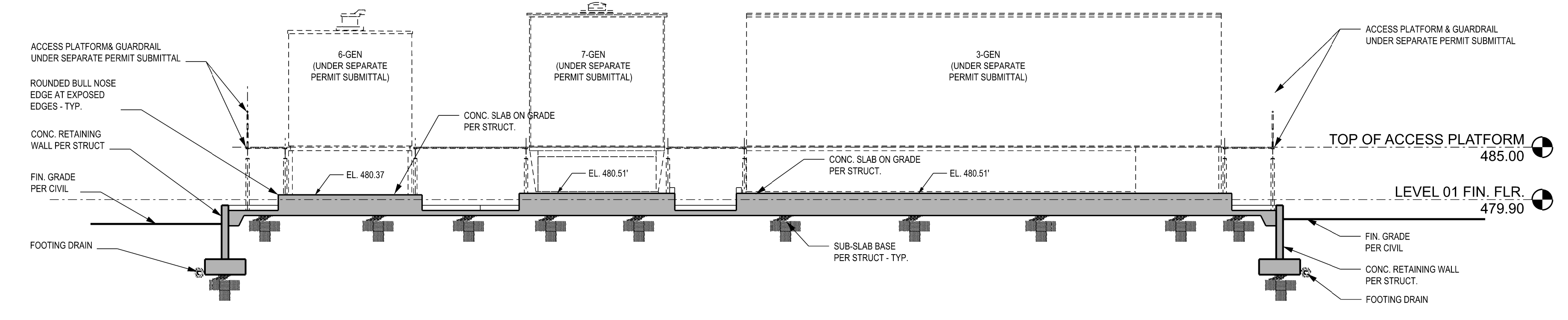

E5 SITE SECTION - GENERATOR PADS - EAST TO WEST - LOOKING NORTH
SCALE: 1/8" = 1'-0"

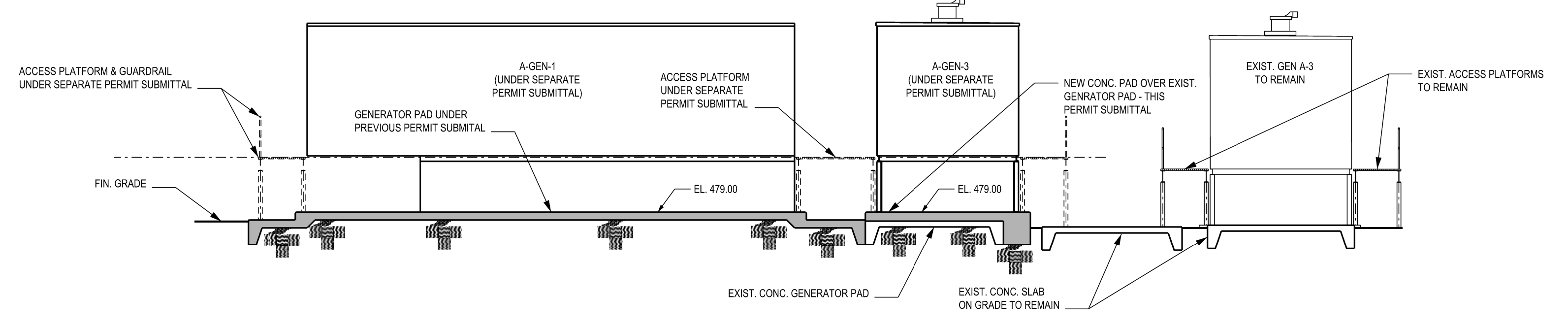

A6 SITE SECTION - GENERATOR PADS - NORTH TO SOUTH - LOOKING WEST
SCALE: 1/8" = 1'-0"