



Contractor to Seed and Mulch all Disturbed Surfaces w/ WSDOT approved Land and Seed Mix

Contractor to Hydroseed and Mulch all Disturbed Surfaces w/ WSDOT approved Erosion control mix w/ Tackifier

**LEGEND**

-  Hydroseed and Mulch
-  Seed and Mulch
-  Property Line

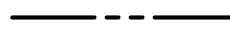
Owner/Developer:



Puyallup School District  
1501 39th Ave SW  
Puyallup, WA 98371  
253-841-8641

Architect:



TCF Architecture  
902 North Second Street  
Tacoma, WA 98403  
253-572-3993

Engineer:



JMJ Team  
905 Main Street, Suite #200  
Sumner, WA 98390  
(206) 596-2020

Project:

Support Campus Expansion  
Improvements - Phase 1

1501 39th Ave SW  
Puyallup, WA 98371

ONE INCH AT FULL SCALE.  
IF NOT, SCALE ACCORDINGLY

Civil Construction Permit



REV	DATE	DESCRIPTION

SHEET TITLE:

**Landscape Plan**

**APPROVED**

BY \_\_\_\_\_  
CITY OF PUYALLUP  
DEVELOPMENT ENGINEERING

DATE \_\_\_\_\_

NOTE: THIS APPROVAL IS VOID AFTER 180 DAYS FROM APPROVAL DATE. THE CITY WILL NOT BE RESPONSIBLE FOR ERRORS AND/OR OMISSIONS ON THESE PLANS. FIELD CONDITIONS MAY DICTATE CHANGES TO THESE PLANS AS DETERMINED BY THE DEVELOPMENT ENGINEERING MANAGER.

PROJ. NO: 1562-008

DATE: March 15th, 2024

DRAWN BY: MO DESIGN BY: JJ

SHEET NUMBER:

**C7-101**

DWG: 13 OF 13

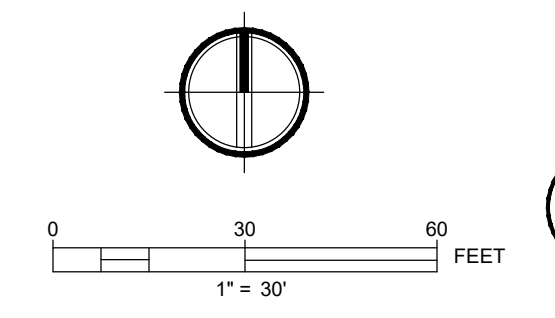

CALL TWO BUSINESS DAYS  
BEFORE YOU DIG

1-800-424-5555  
UTILITIES UNDERGROUND LOCATION CENTER

File: 1562008C-UBSC - Phase 1.dwg Path: J:\1562 - TCF Architecture\008 - PUY SH\04 - CD - Phase 1\1\ Plotted by: JMJ Date: 15-Mar-24 7:20:13pm