

FULL SIZED LEDGIBLE REPORT IS REQUIRED TO BE PROVIDED BY THE PERMITTEE ON SITE FOR ALL INSPECTIONS

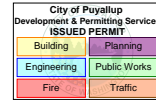

Submittal

Job/Project: 23-04056 Centeris Data Center 2023	Representative: CHC - Columbia
ESP-Systemwize: WIZE-0BBC1FCA Created On: 12/07/2023	Phone: (510)293-1993
Location/Tag: CHP- 3	Email: mtikhanchikov@chchydro.com
Engineer: Wood-Harbinger, Inc.	Submitted By: Michael Tikhanchikov Date: 12/07/2023
Contractor: Hermanson Company LLP	Approved By: Date:

### Base Mounted End Suction Pump

Series: e-1510

Model: 4EB

#### Features & Design

- ANSI/OSHA Coupling Guard
- Center Drop Out Spacer Coupling
- Fabricated Heavy Duty Baseplate
- Internally Self-Flushing Mechanical Seal

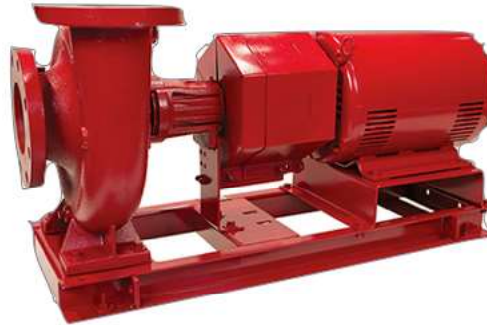

\*The Bell & Gossett Series e-1510 is available in 26 sizes and a variety of configuration options that enable customization and flexibility to fit a broad range of operating conditions.

<http://bellgossett.com/pumps-circulators/end-suction-pumps/e-1510/>

### Pump Selection Summary

Duty Point Flow	593.0 US gpm
Duty Point Head	92.0 ft
Control Head	27.6 ft
Duty Point Pump Efficiency	80.4 %
Part Load Efficiency Value (PLEV)	75.6 %
Impeller Diameter	10.5 in
Motor Power	20 hp
Duty Point Power	17 bhp
Motor Speed	1800 rpm
RPM @ Duty Point	1713 rpm
NPSHr	7.51 ft
Minimum Shutoff Head	108 ft
Minimum Flow at RPM	131 US gpm
Flow @ BEP	654 US gpm
Fluid Temperature	68 °F
Fluid Type	Water
Weight (approx. - consult rep for exact)	602 lbs
Pump Floor Space Calculation	6.65 ft <sup>2</sup>

### Performance Curve

#### Energy Efficiency Ratings:

Pump & Motor PEIc: 0.94 ERcI: 6  
 Pump, Motor & Drive: PEIv: 0.46 ERvI: 54



**e-1510**  
**4EB**  
**1713 RPM**

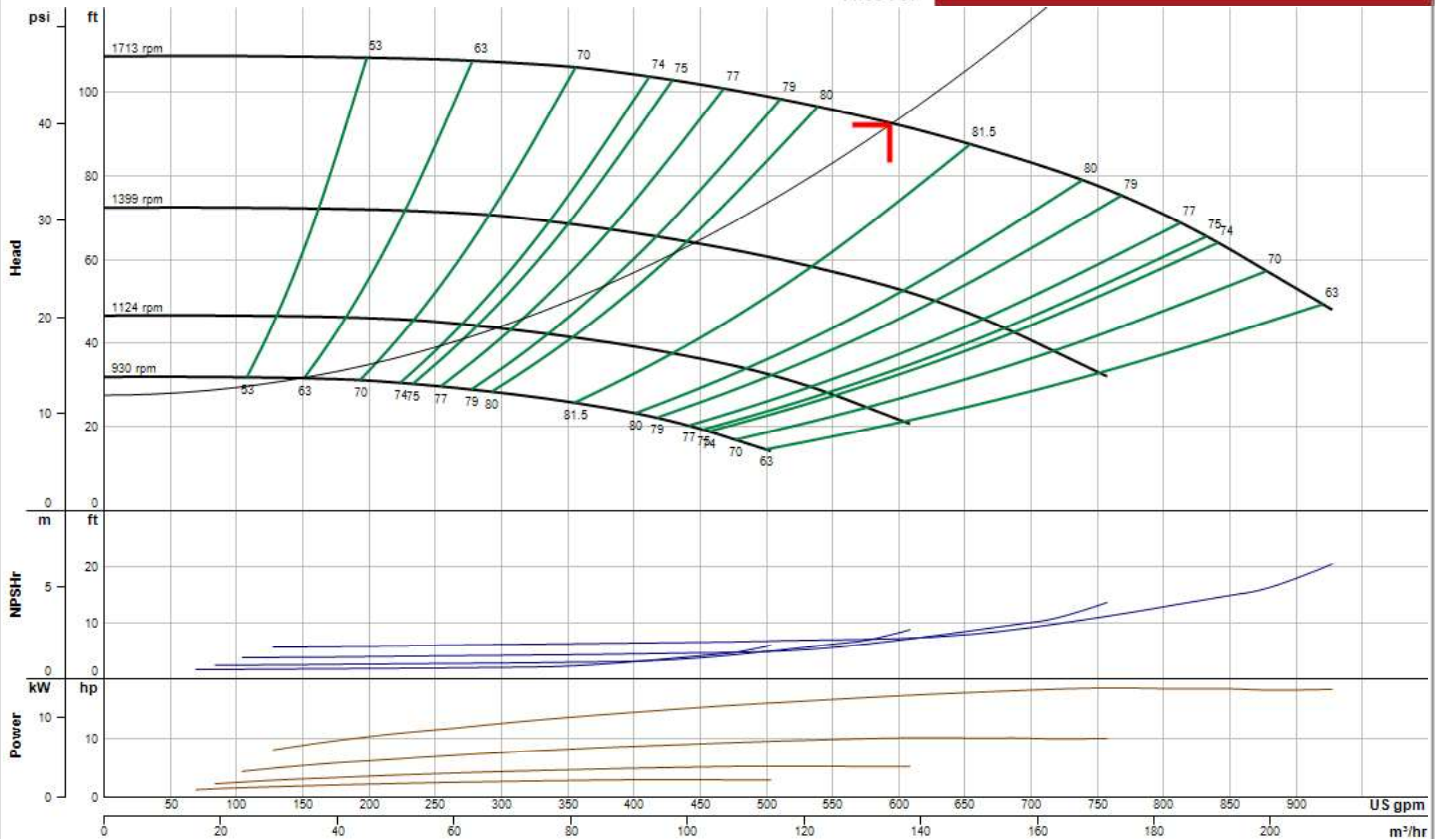

Performance curve meets 14.6 / ISO 9906 acceptance criteria

### Multiple Pump Curve

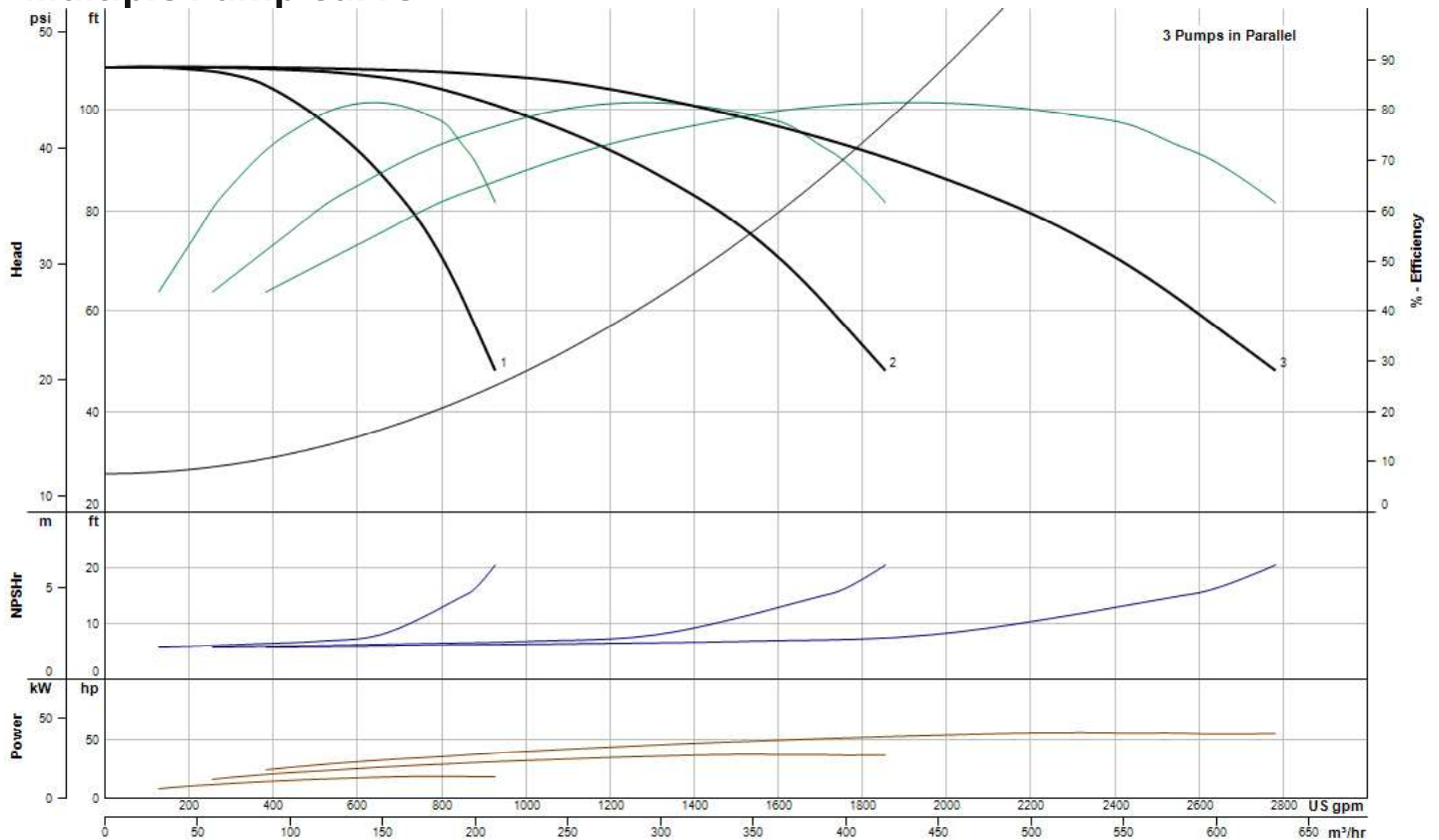

### Best Efficiency Staging

Single pump variable staging possible?			Yes		
System curve crosses full speed curve			No	Yes	Yes
Load	Weight	Best eff	1 Pump	2 Pumps	3 Pumps
100%	1%	80.4			80.4
75%	42%	79.6		77.6	79.6
50%	45%	81.3		81.3	76.1
25%	12%	74.5	74.5	71.7	62.5
Optimal Staging PLEV		79.8			

**Single Pump Variable Staging** - This determination is based on whether the system curve crosses the variable speed curves for the pumps. A "NO" in this box indicates that even at 25% load you need to stage more than one pump to meet system demand. A "YES" indicates that the required head and flow for 25% can be satisfied by a single pump. If the system curve does not cross the single pump curve at full speed, then protections for overload will need to be configured in the drive to avoid falling off the curve.

**Grid values** - A blank box on the grid indicates that the load listed in the row cannot be satisfied by the number of pumps listed in the column. An efficiency value on the grid indicates the approximate hydraulic efficiency for the load in that row based upon staging the number of pumps in the column at the required speed to achieve that flow point. The darkest shaded green box indicates the optimal number of pumps to stage for maximum efficiency at that load.

**Optimal staging PLEV** - This is the estimated weighted average PLEV achieved based upon the maximum efficiency staging at each of the four load points.

### Constant Speed Curve (1750 rpm)

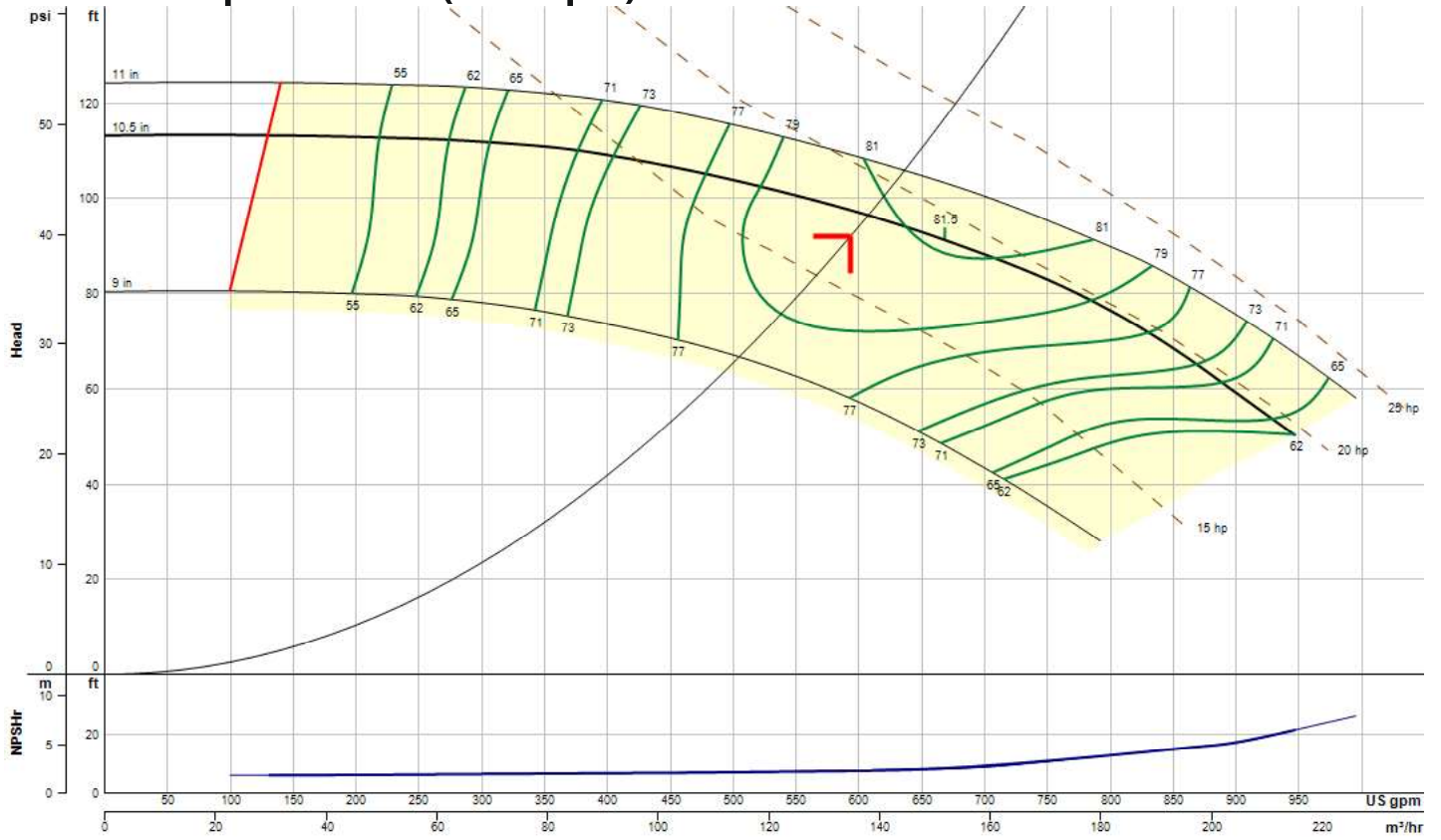

**Operating Point**

Flow: 593 US gpm Head: 92 ft Speed: 1713 Efficiency: 80.4% Point BHP: 17 End Of Curve: 64%

**Maximum Duty Point (at rated motor speed)**

Flow: 606 US gpm Head: 96.1 ft Speed: 1750 Efficiency: 80.4% Point BHP: 18.1 NOL Flow: 785 US gpm Runout Flow: 947 US gpm NOL (BHP): 19.7

## Materials Of Construction

Pump Information\Construction	
Pump Series	e1510
Pump Size	4 EB
Seal Type	Standard Seal
Seal Material	STD-Buna/Carbon/Ceramic/SS/Bronze
Material of Construction	Stainless Steel
Impeller Diameter	10.5 inches
Sleeve Material	Stainless Steel Sleeve

VFD Details	
VFD_Nema	None
Variable_Speed_On	True
Variable_Speed	1713

Motor Details	
Motor Power	20
Motor Speed	1800
Frequency	60
Phase	3
Voltage	230/460
Frame	256T
Enclosure	DPPE
Motor Manufacturer	Baldor
Motor Status	MO
Motor Comments	Nema Premium Eff, Super-E w/Aegis sgr

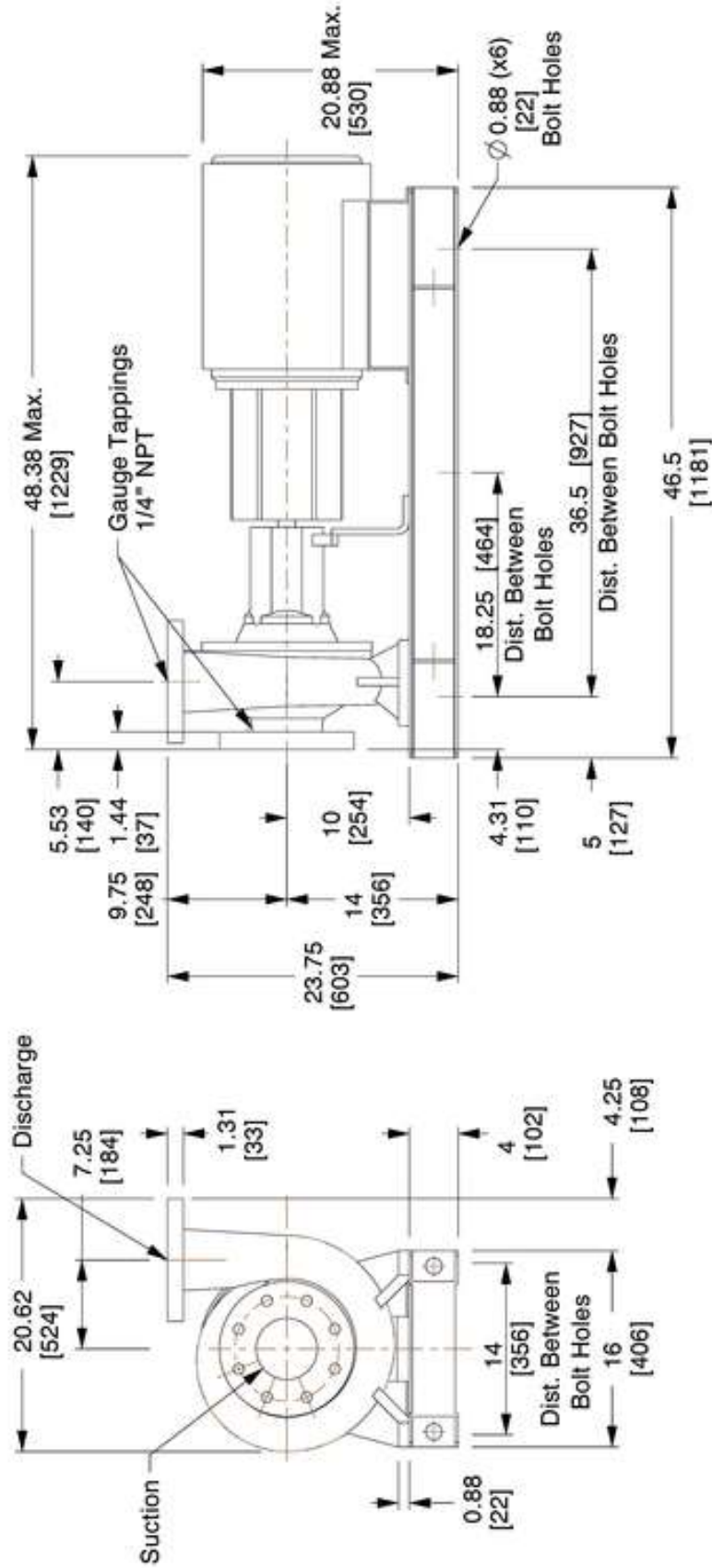
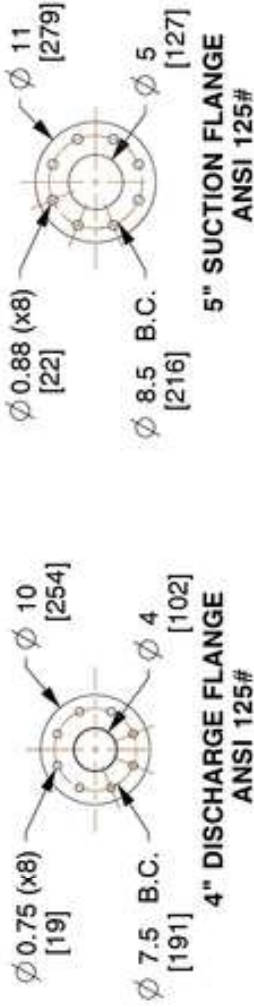

This drawing and the information depicted therein is the property of Xylem. Copies are issued in strict confidence and shall not be reproduced or copied, or used as the basis for the manufacture or sale of products without prior written permission of Xylem.

Dimensions are subject to change  
 Not to be used for construction unless certified

**Bell & Gossett**  
 a xylem brand

8200 N. Austin Ave.  
 Morton Grove, IL 60053, USA

**BG-E1510-4EB-SS-256T-L**

Series e-1510 Centrifugal Pumps - Base Mounted  
 Seal Type: Standard Seal | Motor Frame: 256T | Frame Type: L | Flange: ANSI 125#

Dimensions : IN (mm)      Scale : N.T.S.      Submittal # : B-880.34D

### Standard Mechanical Configuration

Standard Mechanical Seal	SM, LG, & XL Bearing Frames	ES Bearing Frame
Temperature Range	-20 to 225°F	-20 to 225°F
Maximum Pressure	175 PSI	175 PSI
pH Limitations	7.0 - 9.0	7.0 - 9.0
Elastomer	Buna	Buna
Rotating Face	Carbon	Carbon
Stationary Face	Ceramic	Silicon Carbide
Hardware	Stainless Steel / Brass	Stainless Steel

Mechanical Seal Options	SM, LG, & XL Bearing Frames		
Temperature Range	-20 to 250°F	-10 to 225°F	-20 to 250°F
Maximum Pressure	175 PSI	175 PSI	175 PSI
pH Limitations	7.0 - 11.0	7.0 - 9.0	7.0 - 12.5.0
Elastomer	EPR (Ethylene Propylene Rubber)	FKM (Viton™ or Fluoroelastomer)	EPR (Ethylene Propylene Rubber)
Rotating Face	Carbon	Carbon	Silicon Carbide
Stationary Face	Tungsten Carbide	Ceramic	Silicon Carbide
Hardware	Stainless Steel / Brass	Stainless Steel	Stainless Steel

Mechanical Seal Options	ES Bearing Frame		
Temperature Range	-20 to 250°F	-10 to 225°F	-20 to 250°F
Maximum Pressure	175 PSI	175 PSI	175 PSI
pH Limitations	7.0 - 11.0	7.0 - 9.0	7.0 - 12.5.0
Elastomer	EPR (Ethylene Propylene Rubber)	FKM (Viton™ or Fluoroelastomer)	EPR (Ethylene Propylene Rubber)
Rotating Face	Silicon Carbide	Carbon	Silicon Carbide
Stationary Face	Tungsten Carbide	Silicon Carbide	Silicon Carbide
Hardware	Stainless Steel / Brass	Stainless Steel	Stainless Steel

### Stuffing Box Configuration

Mechanical Seal	SM, LG, & XL Bearing Frames
Temperature Range	-20 to 250°F*
Maximum Pressure	175 PSI (Optional 250 PSI)
pH Limitations	7.0 - 11.0
Elastomer	EPR (Ethylene Propylene Rubber)
Rotating Face	Tungsten Carbide
Stationary Face	Carbon
Hardware	Stainless Steel

Packing Option	
Temperature Range	0 to 250°F
Maximum Pressure	175 PSI
pH Limitations	7.0 - 9.0
Material	Braided Graphite Impregnated PTFE

\* For operating temperatures above 250°F a cooled flush is required and is recommended for temperatures above 225°F for optimum seal life. On closed systems cooling is accomplished by inserting a small heat exchanger in the flush line to cool the seal flushing fluid.  
Flush-line Filters and Sediment Separators are available on special request.

### Materials of Construction

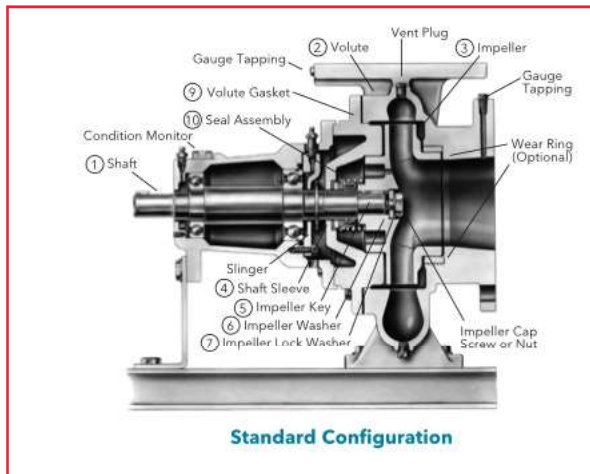

Standard Configuration

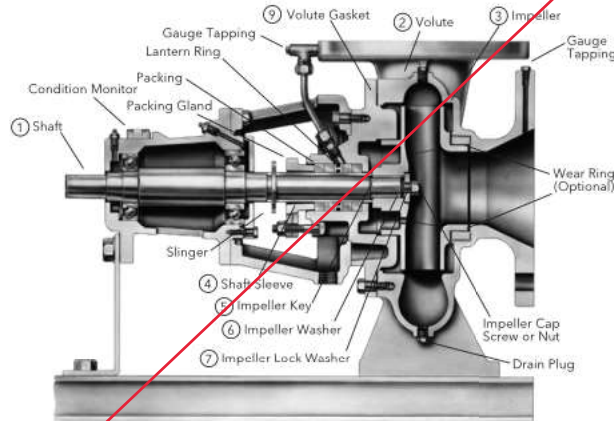

Optional - S Configuration

Description	SM, LG, & XL Bearing Frames	ES Bearing Frame
1 Shaft	ASTM 108 Grade 1144	ASTM 108 Grade 1144
2 Volute	Cast Iron ASTM A48 Class 30B	Cast Iron ASTM A48 Class 30B
3 Impeller	ASTM A743 Grade CF8 - 304 Stainless Steel	ASTM A743 Grade CF8 - 304 Stainless Steel
4 Shaft Sleeve	ASTM 312 Grade TP304 - 304 Stainless Steel	ASTM 312 Grade TP304 - 304 Stainless Steel
5 Impeller Key	#304 Stainless Steel	NA
6 Impeller Washer	Steel	NA
7 Impeller Lock Washer	#304 Stainless Steel (18-8 XL FRM)	NA
8 Impeller Cap Screw	#304 Stainless Steel	NA
8 Impeller Nut	NA	316 Stainless Steel
9 Volute Gasket	Cellulose Fiber	Cellulose Fiber
10 Seal Assembly	Reference Seal Data Tables	Reference Seal Data Tables

### Pump Options

- Stainless Steel Volute Wear Ring
- Galvanized Steel Drip Pan
- Stainless Steel Shaft
- Rexnord Omega Spacer Coupling
- Falk T31 Spacer Coupling
- External Flush Line
- Stuffing Box Configuration
- Epoxy Coated Internal Cast Iron Components
- Special Impeller Balancing (ISO 1940 G2.5 or G1.0)
- Certified Performance Tests (Per HI Standard 14.6)
- 250 PSI Working Pressure

Job/Project: 23-04056 Centeris Data Center 2023	Representative: CHC - Columbia
ESP-Systemwize: WIZE-6F722E26 12/07/2023	Phone: (510)293-1993
Location/Tag: Suction Diffuser	Email: mtikhanchikov@chhydro.com
Engineer: Wood-Harbinger, Inc.	Submitted By: Michael Tikhanchikov Date: 12/07/2023
Contractor: Hermanson Company LLP	Approved By: Date:

**Suction Diffuser Plus**  
**Bell & Gossett Model: GF-3X**

The Bell & Gossett Suction Diffuser Plus is designed for direct application to the pump suction and provides ideal flow conditions for the pump, providing NPSH requirements are met. Its integrated Flow Cone directs flow through the unit and into the pump suction while working with the full length straightening vanes to create a more uniform flow profile. The orifice cylinder has a free area equal to five times the cross section of the pump suction opening and serves as a coarse strainer to protect the pump from large sediment. Type X-For Closed Systems



<http://bellgossett.com/hydronic-plumbing-accessories/pump-accessories/suction-diffuser/>

**Suction Diffuser Selection**

Model	GF-3X
System Size	6.0 in
Pump Size	5.0 in
Connection Type	Flanged/Flanged
Cv	625
Fluid Type	Water
Fluid Temp	68 °F

**Performance characteristics:**

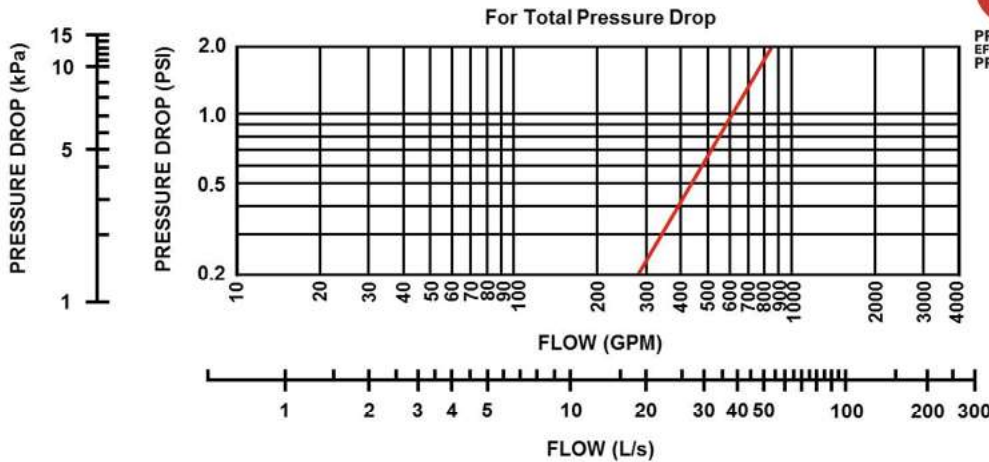

**GF-3X**

**Materials of construction**

Body	Cast Iron
Inlet Vanes	Steel
Orifice Cylinder	Steel
Start-up Strainer	16 Mesh Bronze

**Operating Data**

Max Working Pressure	175 psi
Max Temp	250°F

**Dimensional data:**

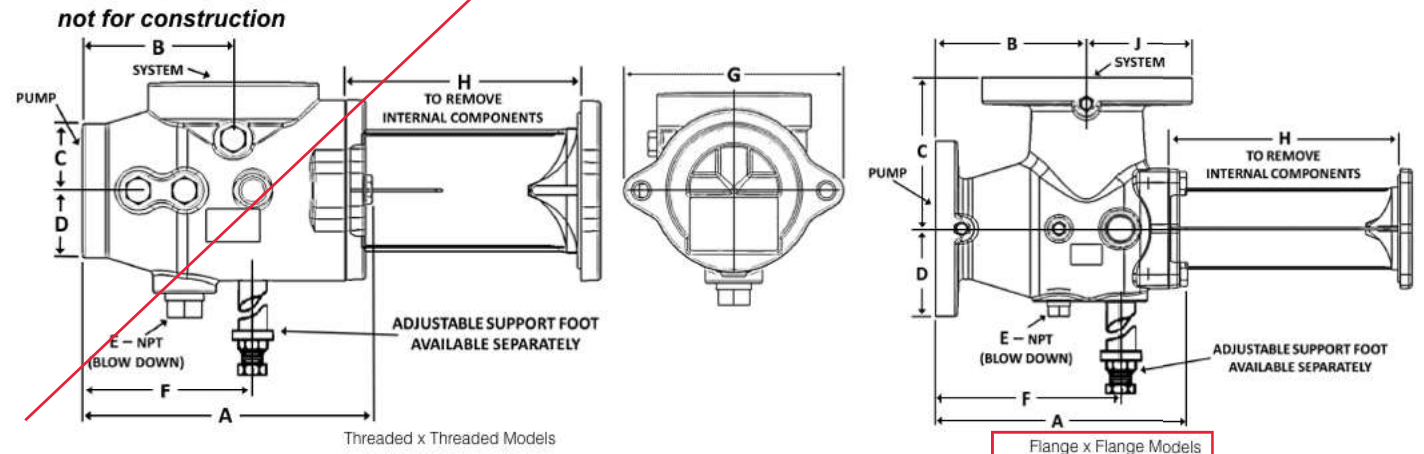

**DIMENSIONS - INCHES (mm)**

Model No.	System Side	Pump Side	A	B	C	D	E	F	G	H	J	Orifice Cylinder Free Area in <sup>2</sup> (cm <sup>2</sup> )	Approx. Shpg. Wt. Lbs. (Kg)		
GF-3	6 (152.4)	F	5 (127)	F	15.67 (398)	8 (203)	8 (203)	5 (127)	3/4 (19)	10.46 (266)	N/A	13.84 (351.5)	5.50 (140)	90 (581)	105 (48)



# Submittal

Job/Project: 23-04056 Centeris Data Center 2023		Representative: CHC - Columbia	
ESP-Systemwize: WIZE-6F722E26	12/07/2023	Phone: (510)293-1993	
Location/Tag: Triple Duty Valve		Email: mtikhanchikov@chhydro.com	
Engineer: Wood-Harbinger, Inc.		Submitted By: Michael Tikhanchikov	Date: 12/07/2023
Contractor: Hermanson Company LLP		Approved By:	Date:

## Triple Duty Valve

### Bell & Gossett Model: 3DS-4B

The Triple Duty Valve is a quiet operating heavy-duty valve which performs all of the functions normally required on the discharge side of hydronic system pumps. The valve serves as a nonslam check valve as needed for zoned pumping, parallel and standby pumping, and condenser water applications. The spring loaded disk prevents valve chatter, and assures positive shutoff.. The Triple Duty Valve is also equipped with Model RV-125A readout valves for more accurate system balance. The calibrated nameplate allows the valve to be returned to the original balance position after shutoff.



### Triple Duty Valve Selection

Model	3DS-4B
Size	4.0 in
Stem Position	60%
Connection Type	Flanged
Cv @ Designated Step Position	135

## Performance Characteristics:

## 3DS-4B

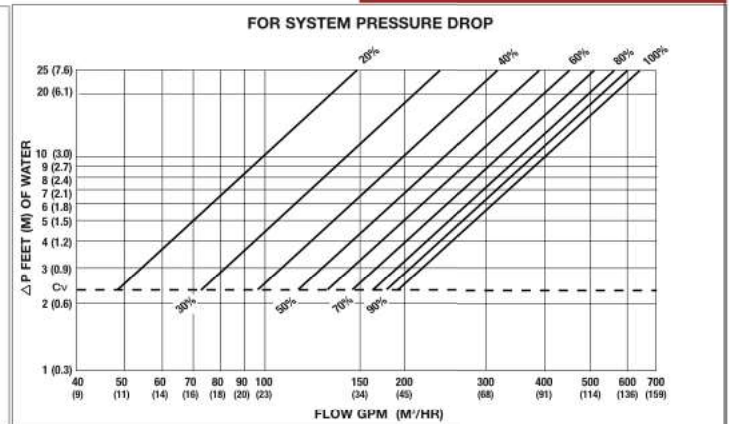
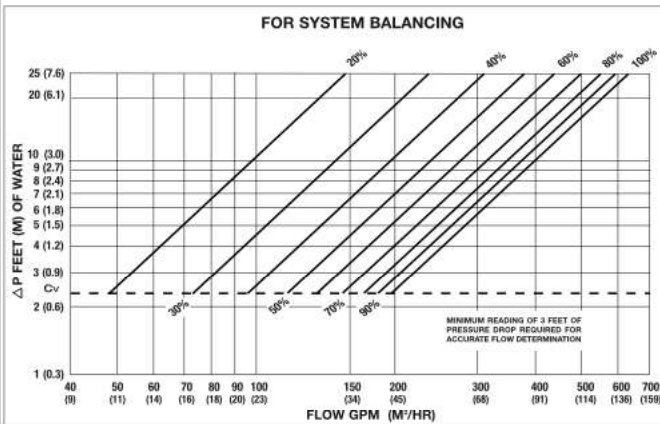

### Materials of construction

Body:	Cast Iron with Bronze seat
Disc	Brass with EPDM Seat Insert
Stem	Stainless Steel
Spring	Stainless Steel
Packing	Teflon-Graphite (asbestos-free)
Gasket	Non-Asbestos
Readout Valve	Brass with EPT insert, check valve & gasket

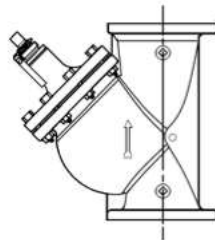

PROPER INSTALLATION SHOWING STEM UPRIGHT

### Operating Limits

Max Working Pressure (standard)	175 psi
Max Temp (standard)	250°F

## Dimensional Data:

not for construction

FLANGE SIZE*	DIMENSIONS IN INCHES (mm)					APPROX. SHPG. WT. LBS. (Kg)	
	OPEN	A	CLOSED	B	C		
4 (101.6)	13.07 (332.00)		12.19 (309.60)	14.50 (368.30)	4.50 (114.30)	3.94 (100.00)	62 (28)

\*STANDARD 125 PSIG (862 kPa) ANSI FLANGES. Dimensions are subject to change. Not to be used for construction purposes unless certified.

Distance required to disassemble (valve closed)

