

FULL SIZED LEDGIBLE REPORT IS REQUIRED TO BE PROVIDED BY THE PERMITTEE ON SITE FOR ALL INSPECTIONS

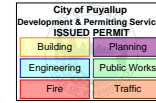

JOB: Centeris Data Centers Data Center Expansion 2023

REPRESENTATIVE: CHC - Columbia

UNIT TAG: CP-1,2
ENGINEER: Wood-Harbinger, Inc.
CONTRACTOR: Hermanson Company LLP

ORDER NO.
SUBMITTED BY: Michael Tikhanchikov
APPROVED BY:

DATE:
DATE: 12/07/2023
DATE:



SERIES PL™

Permanently Lubricated Iron & Lead-Free† Bronze Booster Pumps



The Series PL™ close coupled booster pumps are specifically designed for quiet operation in hydronic, radiant and geothermal heating and cooling systems. These inline permanently lubricated pumps are available in **cast iron** or ~~lead-free† bronze~~ body construction.

OPERATING DATA

Maximum working Pressure: 150 psi (10 Bar)
Maximum Operating Temperature: 225°F (107°C)

†Contains less than 0.25% Lead content by weight on wetted surfaces.

CONSTRUCTION MATERIALS

Booster Body: **Cast Iron** or ~~Lead-Free† Bronze~~
Face Plate: Stainless Steel

Impeller: PL-55, PL-100, PL-130, PL-130 are Glass Filled PPS
→ PL-30, PL-36, PL-45, PL-50, PL-75, are 30% Glass Filled Noryl®

Shaft: PL-55, PL-100, PL-130, PL-130 are Stainless Steel
→ PL-30, PL-36, PL-45, PL-50, PL-75, are Carbon Steel with Stainless Steel Sleeve

Seal: Mechanical, Carbon on Silicon Carbide
Elastomers: EPDM
Motor Bearings: Sealed Precision Steel Ball Bearing
Permanently Lubricated Motor Type: ODP

CAST IRON			LEAD-FREE† BRONZE			STANDARD 60 CYCLE SINGLE PHASE MOTOR CHARACTERISTICS				TAGGING INFORMATION
MODEL NUMBER	PART NUMBER	QTY.	MODEL NUMBER	PART NUMBER	QTY.	HP	VOLTAGE	F.L. AMPS	RPM	
PL-30	1BL012		PL-30B	1BL013LF		1/12	115	1.4	2650	
PL-30	1BL014		PL-30B	1BL015LF		1/12	230	0.8	2650	
→ PL-36	1BL001	2	PL-36B	1BL009LF		1/6	115	2.1	3300	CP-1,2
PL-36	1BL006		PL-36B	1BL008LF		1/6	230	1.1	3300	
PL-36	1BL116		PL-36B	1BL118LF		1/6	277	1	3300	
PL-45	1BL002		PL-45B	1BL004LF		1/6	115	2.1	3300	
PL-45	1BL007		PL-45B	1BL009LF		1/6	230	1.1	3300	
PL-45	1BL121		PL-45B	1BL122LF		1/6	277	1	3300	
PL-50	1BL016		PL-50B	1BL017LF		1/6	115	1.8	3300	
PL-50	1BL018		PL-50B	1BL019LF		1/6	230	1.0	3300	
PL-50	1BL123		PL-50B	1BL124LF		1/6	277	1.0	3300	
PL-55	1BL032		PL-55B	1BL068LF		2/5	115	4.7	3250	
PL-55	1BL033		PL-55B	1BL069LF		2/5	230	2.4	3250	
PL-55	1BL115		PL-55B	1BL119LF		2/5	277	1.9	3250	
PL-75	1BL034		PL-75B	1BL035LF		1/6	115	2.1	3400	
PL-75	1BL036		PL-75B	1BL037LF		1/6	230	1.1	3400	
PL-75	1BL125		PL-75B	1BL126LF		1/6	277	1	3400	
PL-100	1BL134		PL-100B	1BL136LF		2/5	115	4.8	3250	
PL-100	1BL135		PL-100B	1BL137LF		2/5	230	2.4	3250	
PL-130/2"	1BL063		PL-130B/2"	1BL065LF		2/5	115	4.8	3200	
PL-130/2"	1BL064		PL-130B/2"	1BL066LF		2/5	230	2.4	3200	
PL-130/2"	1BL127		PL-130B/2"	1BL128LF		2/5	277	1.9	3200	
PL-130/3"	1BL070		PL-130B/3"	1BL072LF		2/5	115	4.8	3200	
PL-130/3"	1BL071		PL-130B/3"	1BL073LF		2/5	230	2.4	3200	
PL-130/3"	1BL130		PL-130B/3"	1BL131LF		2/5	277	1.9	3200	

Note: Where potable water is pumped, use a lead-free† bronze booster. PL boosters equipped with a drip-proof motor are recommended for indoor use only.

SERIES PL - Permanently Lubricated Booster Pumps

A-135H

DIMENSIONS AND WEIGHTS

MODEL NUMBER	FLANGE SIZE INCHES - NPT	MOTOR HP	DIMENSIONS - INCHES (mm)					APPROXIMATE SHIPPING WT. LBS. (KG)
			A	B	C	D	E	
PL-30	3/4, 1, 1-1/4 & 1-1/2	1/12	8 5/8 (219)	6 3/8 (162)	7 1/8 (181)	4 3/16 (106)	4 3/8 (111)	11.6 (5.3)
PL-36	3/4, 1, 1-1/4 & 1-1/2	1/6	8 5/8 (219)	6 3/8 (162)	7 1/8 (181)	4 3/16 (106)	4 3/8 (111)	13.1 (6.0)
PL-45	1, 1-1/4 & 1-1/2	1/6	9 1/8 (232)	8 1/2 (216)	7 1/4 (184)	4 5/8 (117)	4 1/2 (114)	14.5 (6.6)
PL-50	1, 1-1/4 & 1-1/2	1/6	9 1/8 (232)	8 1/2 (216)	7 1/4 (184)	4 5/8 (117)	4 1/2 (114)	14.5 (6.6)
PL-55	3/4, 1, 1-1/4 & 1-1/2	2/5	9 9/16 (243)	6 3/8 (162)	7 15/16 (202)	4 3/16 (106)	4 3/4 (121)	13.1 (6.0)
PL-75	2	1/6	9 15/16 (252)	8 1/2 (216)	7 3/8 (187)	5 3/16 (132)	4 5/8 (117)	18.5 (8.4)
PL-100	1, 1-1/4 & 1-1/2	2/5	9 1/8 (232)	8 1/2 (216)	7 1/4 (184)	4 5/8 (117)	4 1/2 (114)	14.5 (6.6)
PL-130/2"	2	2/5	10 3/4 (273)	8 1/2 (216)	8 1/4 (210)	5 3/16 (132)	5 1/8 (130)	22 (10)
PL-130/3"	3	2/5	10 3/4 (273)	8 1/2 (216)	8 1/4 (210)	6 (152)	5 1/8 (130)	27 (12.2)

Dimensions are approximate and subject to change. Contact factory for certified dimensions.

TYPICAL SPECIFICATIONS

The contractor shall furnish and install inline pumps as illustrated on the plans and in accordance with the following specifications:

1. The pumps shall be of the horizontal, permanently lubricated type, specifically designed and guaranteed for quiet operation.
 2. The pumps shall have a steel shaft supported by permanently lubricated, sealed precision ball bearings. The pumps are to be equipped with a water-tight seal to prevent leakage. Mechanical seal faces to be carbon on silicon carbide. The motor shall be non-overloading at any point on the pump performance curve.
 3. The motor shall be of the drip-proof, sealed precision ball-bearing, quiet-operating construction. The permanent split-capacitor motor shall be equipped with thermal overload protection.
 4. Pumps to be suitable for 225°F (107°C) operating temperature at 150 psig (10 bar) working pressure.
- The pumps shall be Bell & Gossett, A Xylem brand. Model No. PL-36 with a capacity of 20 GPM at 15' feet of head.

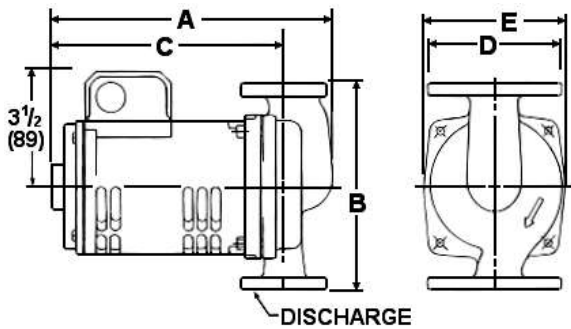

PERFORMANCE CHARACTERISTICS CURVES

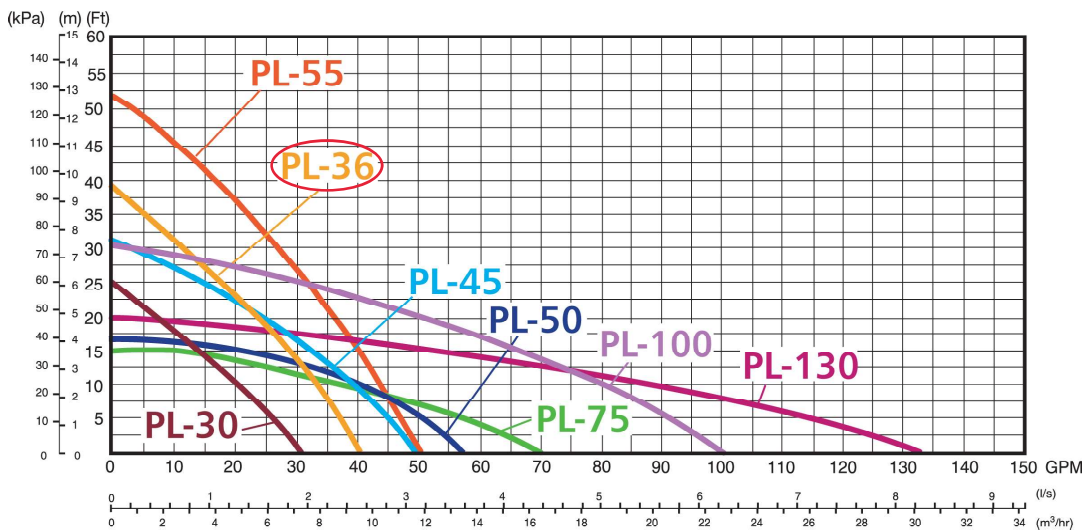

Xylem Inc.
 8200 N. Austin Avenue
 Morton Grove, IL 60053
 Phone: (847) 966-3700
 Fax: (847) 965-8379
 www.xylem.com/bellgossett

Bell & Gossett is a trademark of Xylem Inc. or one of its subsidiaries.
 © 2019 Xylem Inc.