

MITIGATION PLAN

EAST TOWN CROSSING STREAM RESTORATION AND MIXED-USE DEVELOPMENT

MARCH 20, 2024



**Soundview
Consultants**

Environmental Assessment
Planning + Land Use Solutions

MITIGATION PLAN

EAST TOWN CROSSING STREAM RESTORATION AND MIXED-USE DEVELOPMENT

MARCH 20, 2024

PROJECT LOCATION

2902, 13102, & 3104 EAST PIONEER AVENUE
813, 901, & 911 SHAW ROAD EAST
PUYALLUP, WASHINGTON 98374

PREPARED FOR

ASH DEVELOPMENT

1001 SHAW ROAD
PUYALLUP, WASHINGTON 98371

PREPARED BY

SOUNDVIEW CONSULTANTS LLC

2907 HARBORVIEW DRIVE
GIG HARBOR, WASHINGTON 98335
(253) 514-8952



**Soundview
Consultants**
Environmental Assessment
Planning + Land Use Solutions

Executive Summary

Soundview Consultants LLC (SVC) has been assisting Ash Development (Applicant) with a Mitigation Plan for the proposed stream restoration and mixed-use development of a 10.93-acre site located at 2902, 13102, and 3104 East Pioneer Avenue and 813, 901, and 911 Shaw Road East in the City of Puyallup, Pierce County, Washington. The subject property consists of seven parcels situated in the Southeast ¼ of Section 26 and the Northeast ¼ of Section 35, Township 20 North, Range 4 East, W.M. (Pierce County Tax Parcel Numbers 0420264021, 0420264053, 0420264054, 0420351030, 0420351029, 0420351026 & 0420351066).

The subject property was previously investigated by John Comis Associates, LLC in 2008, 2009, and 2020 for the presence of potentially regulated wetlands, waterbodies, and fish and wildlife habitat conservation areas, with follow-up investigations in 2020 to verify initial findings. More recently, Habitat Technologies investigated the site in 2021 and again in 2022. Using current methodology, John Comis Associates (2020) and Habitat Technologies (2021) confirmed the absence of onsite wetlands. However, Habitat Technologies identified two streams on the eastern and northern portions of the site and one potential wetland offsite to the east of the site. Habitat Technologies later treated the potential wetland offsite to the east of the site as a wetland; however, no wetland hydrology indicators were observed during a summer site investigation (Habitat Technologies, 2022). The east stream (herein referred to as Stream Y) is classified as a Type IV water and the north stream (herein referred to as Stream Z) is classified as a Type III water per Puyallup Municipal Code (PMC) 21.06.1010(3)(a). Type III streams are subject to a standard 50-foot buffer, and Type IV streams are subject to a standard 35-foot buffer per PMC 21.06.1050(2). The wetland identified offsite to the east was preliminarily classified as a Category III wetland with an associated 80-foot buffer under PMC 21.06.930(2). In addition, John Comis Associates identified and delineated one wetland (previously Wetland A, herein referred to as Wetland 1) offsite to the south, as previously delineated by Herrera Environmental Consultants in 2000. Wetland 1 was classified as a Category II wetland subject to a standard 100-foot buffer per PMC 21.06.930(2).

SVC investigated the area offsite to the east for the presence of potentially-regulated wetlands, waterbodies, fish and wildlife habitat, and/or priority habitats or species in February 2023. Using current methodology, the site investigation confirmed the absence of wetlands in the area of Habitat Technologies' preliminary wetland determination in 2022. No areas met all three required wetland delineation criteria (a predominance of hydrophytic vegetation, hydric soils, and wetland hydrology). Specifically, no wetland hydrology was observed under normal hydrologic conditions during the winter wet season when groundwater was fully recharged. No other potentially-regulated wetlands, waterbodies, or priority habitats or species were identified within 300 feet of the site. Offsite wetland determinations will be discussed in detail under separate cover. SVC conducted a joint site investigation with Washington State Department of Fish and Wildlife (WDFW) on July 19, 2023. During the site investigation, WDFW concluded that Streams Y and Z are Type F (fish habitat) streams.

The Applicant proposes a phased project to construct a mixed-use development. Phase I will include development of residential and commercial buildings, parking, utilities, stormwater infrastructure, and frontage improvements along Shaw Road East. Phase II of the project will implement the required frontage improvements along East Pioneer Avenue and expand the mixed-use development onsite. The proposed project has been carefully designed to avoid and minimize impacts to the greatest extent

feasibly by utilizing the existing disturbed upland areas onsite. During Phase I, the proposed project will avoid in-water work and locate buildings and parking areas outside of modified buffers. Work within the critical area buffers will be limited to the utility crossings of the Stream Z buffer necessary to connect to existing infrastructure, the relocation of a power pole within the Stream Z buffer necessary to support required frontage improvements along East Pioneer Avenue, work necessary to provide site access from East Pioneer Avenue, and the work needed to maintain site drainage patterns. Stormwater discharge locations are proposed to be located landward of OHW. To ensure no net loss of ecological functions from Phase I, the project proposes to provide modified stream buffers that provide an equivalent buffer area as the standard buffers required per PMC 21.06.1050(2) and to rectify temporary buffer impacts (1,345 square feet) by seeding temporarily disturbed areas with a native seed mix. The proposed modified stream buffers consist of 866 square feet of Stream Z buffer decrease and 1,030 square feet of Stream Z increase.

During Phase II of the project, required frontage improvements and the proposed Stream Z crossing for site access cannot avoid critical area impacts. Given the location of Stream Z within the existing right-of-way (ROW) of East Pioneer Avenue, shifting Stream Z south is necessary and unavoidable to provide updated sidewalk, curb gutters, and landscaping to meet current City requirements. Given the proposed mixed-use development with several apartment buildings and commercial space, one site access point from Shaw Road East is not practicable. Therefore, the existing crossing from East Pioneer Avenue will need to be upgraded and widened to provide safe site access for the new development across the realigned Stream Z; the upgraded crossing will alleviate traffic issues by aiding in vehicle circulation and splitting use between two arterials and will also allow multiple access points for safety vehicles. The crossing will be designed as a bottomless culvert to allow for fish passage. Due to the realignment of Stream Z, the onsite buffer width for the new Stream Z channel is proposed to be less than the standard 50-foot buffer for a Type III stream required per PMC 21.06.1050(2), resulting in 3,594 square feet of buffer decrease. PMC 21.06.1030(1) states that relocation of Type II, III, and IV streams are permitted when the action will result in equal or better habitat and water quality and will not diminish the flow capacity of the stream. The mitigation actions described herein demonstrate how the project is anticipated to increase ecological functions when compared to the existing degraded conditions of the streams.

To offset the necessary and unavoidable direct impacts to Stream Z during Phase II, the project proposes to restore and realign Stream Z within a reestablished, riparian corridor on the northern portion of the project area. In the existing linear, ditched alignment, Stream Z is extremely degraded as the system lacks riparian cover, habitat complexity, and floodplain function and is situated in a roadside ditch with several piped segments. The proposal will provide a highly functional stream with large woody debris, flood benches, and dense riparian plantings that will all increase the complexity and functionality of the stream system. In addition, the Applicant proposes to voluntarily restore Stream Y in a new stream channel near the eastern property boundary and to enhance buffer areas surrounding the new stream channel during Phase II. In its existing alignment, Stream Y is diverted into a stormwater pond and then piped for approximately 471 feet before discharging into Stream Z along East Pioneer Avenue. Therefore, in its current alignment, Stream Y is extremely degraded and restoring the stream channel and providing buffer enhancement will increase stream habitat availability and functions. Habitat Technologies previously described Stream Z and Stream Y as seasonal streams. The streams are tributaries to Deer Creek, which provides habitats for a number of fish species. However, prior assessments by Habitat Technologies and the Puyallup Tribe did not document fish utilization within the ditch system associated with the Pioneer Way East Corridor east of the confluence with Deer Creek (Habitat Technologies, 2022). WDFW has classified the streams as Type

F (fish habitat). The proposed project will restore and enhance 74,796 square feet of buffer surrounding Streams Y and Z. The proposed buffer restoration and enhancement will provide 14,566 square feet of additional buffer in excess of the buffer areas that would be required under the standard 50-foot buffer required for Type III stream and a standard 35-foot buffer required for a Type IV stream.

The mitigation plan will provide a comprehensive stream restoration approach with watershed-level benefits to significantly increase stream functions of two tributaries that drain to Upper Deer Creek approximately 0.25-mile offsite to the west. Upper Deer Creek drains to the Puyallup River and is a gradient accessible stream for coho, Chinook, chum, pink and steelhead and also has known trout populations. In addition, Upper Deer Creek has documented water quality issues due to the 4A listing for high levels of bacteria from fecal coliform. Downgradient of the site, the Puyallup River also has documented water quality issues due to the 303d listings for high levels of bacteria from fecal coliform, high water temperatures, and high levels of mercury; these 303d listings resulted in the development of Puyallup River Watershed Fecal Coliform Total Maximum Daily Load (TMDL) Water Quality Report and Implementation Plan (WSDOE, 2011). The Puyallup River TMDL identifies Deer Creek in the Shaw Road area near the project site as an ideal area to restore riparian habitat. Further, both streams are within mapped FEMA 100-year floodplain but currently provide de minimis flood functions due to the straightened, ditched conditions. Restoring stream and riparian habitat will improve usable fish habitat within Stream Z over time, increase sediment and pollutant filtration to improve documented water quality issues, and provide flood benches to increase hydrologic functions and flow capacity that will reduce local flooding. Therefore, the project is aligned with the Puyallup River TMDL and is anticipated to result in a net gain in ecological functions in the watershed when compared to the existing degraded conditions of the stream that will be impacted from the frontage improvements and upgraded crossing. A Conceptual Mitigation Plan is provided in Chapter 2 of this report.

The City issued a Mitigated Determination of Non-Significance (MDNS) dated June 27, 2023 (City of Puyallup, 2023b) for the proposed project’s Conceptual Mitigation Plan dated April 7, 2023 and provided conditions of approval in a Final Development Review Team Letter dated June 20, 2023 (City of Puyallup, 2023a). In addition, the City issues Civil Review Comments for the proposed site plan August 31, 2023 (City of Puyallup, 2023c). The proposed site plan and mitigation plan have been updated based on the City’s conditions of approval provided in the Final Development Review Team Letter, the coordination with WDFW, and the civil review comments. Most recent changes to the site plan include a reduction in the number of proposed parking stalls, relocation of two buildings to reduce impacts to the buffer of Stream Z, and the relocation of a power pole along East Pioneer Avenue further within the buffer of Stream Z to support frontage improvements along the road.

The table below identifies the critical areas and summarizes the potential regulatory status by local, state, and federal agencies.

Wetland/ Waterbody Name	City Category/ Type ¹	State Category/Type ²	Regulated Under PMC Chapter 21.06	Regulated Under RCW 90.48	Regulated Under Clean Water Act
Wetland 1	II	II	Yes	Yes	Likely
Stream Y	Type IV	F	Yes	Yes	Likely
Stream Z	Type III	F	Yes	Yes	Likely

Note:

1. Current Washington State Department of Ecology (WSDOE) wetland rating system (Hruby, 2014) per PMC 21.06.910(3); stream definitions per PMC 21.06.1010(3)(a) and Habitat Technologies (2021).
2. Current Washington State Department of Ecology (WSDOE) wetland rating system (Hruby, 2014) per PMC 21.06.910(3); stream classifications per Washington Administrative Code (WAC) 222-16-030.

The table below identifies the proposed stream impacts.

Stream	City Type ¹	State Type ²	Impact Type	Impact Area
Z	Type III	Type F	Direct	592 LF

Note:

1. Stream definitions per PMC 21.06.1010(3)(a) and Habitat Technologies (2021).
2. Stream classification per Washington Administrative Code (WAC) 222-16-030.

The summary table below identifies linear feet of stream segments in the project area pre- and post-development.

Stream	City Type ¹	State Type ²	Condition	Existing	Proposed
Y	IV	F	Open Channel	110 LF	463 LF
			Culvert	471 LF	0 LF
			Total	581 LF	463 LF
Z	III	F	Open Channel	465 LF	475 LF
			Culvert	127 LF	138 LF
			Total	592 LF	613 LF

Note:

1. Stream definitions per PMC 21.06.1010(3)(a) and Habitat Technologies (2021).
2. Stream classification per Washington Administrative Code (WAC) 222-16-030.

Site Map

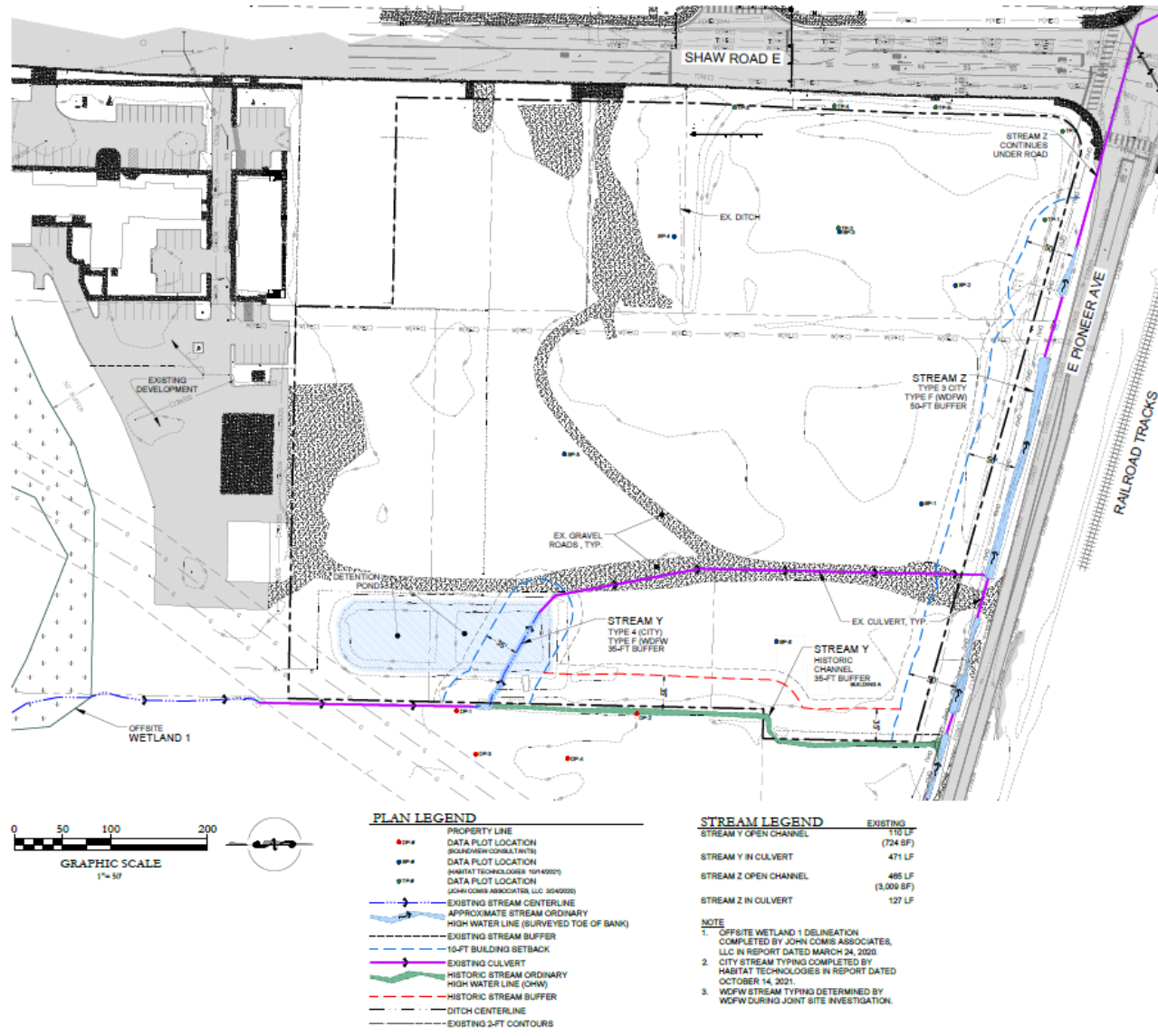

Table of Contents

Chapter 1. Regulatory Considerations	1
1.1 Local Considerations	1
1.2 State Considerations	6
1.3 Federal Considerations.....	6
Chapter 2. Conceptual Mitigation Plan	8
2.1 Purpose and Need.....	8
2.2 Description of Impacts	8
2.3 Stream and Riparian Mitigation Strategy	10
2.4 Approach and Best Management Practices.....	13
2.5 Mitigation Implementation.....	13
2.6 Goals, Objectives, and Performance Standards	15
2.7 Plant Materials and Installation.....	17
2.8 Maintenance & Monitoring Plan	19
2.9 Reporting.....	20
2.10 Contingency Plan and Long-Term Management Plan	20
Chapter 3. Closure	22
Chapter 4. References	23

Tables

Table 1. Stream Impact Summary.....	9
Table 2. Summary of Stream Segments Pre- and Post-Development.....	11

Appendices

- Appendix A – Proposed Site Plan Exhibits
- Appendix B – Photographs
- Appendix C – Qualifications

Chapter 1. Regulatory Considerations

The proposed project utilizes a combination of prior referenced critical area reports and current site investigations for a complete determination of identified critical areas. John Comis Associates (2020) established the presence of offsite Wetland 1 (previously referred to as Wetland A) south of the subject property. Most recently, Habitat Technologies (2021) confirmed the absence of onsite wetlands and the presence of two onsite streams (Streams Y and Z) on the eastern and northern portions of the site, respectively. A copy of the prior referenced critical areas report is provided under separate cover. In addition, SVC's site investigation in February 2023 confirmed the absence of offsite wetlands to the east of the subject property. No other potentially-regulated wetlands, waterbodies, fish and wildlife habitat, or priority habitats or species were identified within 300 feet of the site during the site investigations.

1.1 Local Considerations

1.1.1 Buffer Standards

PMC 21.06.910(3) has adopted the current wetland rating system for western Washington (Hruby, 2014). Category II wetlands provide a high level of function and ecological characteristics. Wetland 1 was identified offsite to the south of the subject property by John Comis Associates (2020). Wetland 1 was classified as a Category II wetland subject to a standard 100-foot buffer per PMC 21.06.930(2). The buffer associated with Wetland 1 does not project onsite.

Habitat Technologies (2021) identified two streams on the eastern and northern portions of the site. The east stream (Stream Y) is classified as a Type IV water and the north stream (Stream Z) is classified as a Type III water per PMC 21.06.1010(3)(a). Type III streams are subject to a standard 50-foot buffer, and Type IV streams are subject to a standard 35-foot buffer per PMC 21.06.1050(2).

A building setback of 10 feet is required for all buildings and structures from the edges of all critical area buffers per PMC 21.06.840.

1.1.2 Mitigation Sequencing

The Applicant proposes necessary and unavoidable direct impacts to Stream Z. Under PMC 21.06.1020(1) and PMC 21.06.1080, adverse impacts to riparian and non-riparian habitats shall be fully mitigated in accordance with the standards set forth in PMC 21.06.610. Per PMC 21.06.610(1), when an alteration to a critical area is proposed, the applicant shall demonstrate that all reasonable efforts have been taken to avoid, minimize, or compensate for impacts in that order with the mitigation definition contain in PMC 21.06.210(84).

a) *Avoiding the impact altogether by not taking a certain action or parts of actions.*

The Applicant proposes a phased project to construct a mixed-use development. Phase I will include development of residential and commercial buildings, parking, utilities, stormwater infrastructure, and frontage improvements along Shaw Road East. Phase II of the project will implement the required frontage improvements along East Pioneer Avenue and Stream Z crossing and expand the mixed-use development onsite.

The proposed project has been carefully designed to avoid and minimize impacts to the greatest extent feasibly by utilizing the existing disturbed upland areas onsite. During Phase I, the proposed project will avoid in-water work (i.e. work below OHW) and locate buildings and parking areas outside of modified buffers. To provide a reasonable site and building layout on the northwest corner of the site, the project proposes decreasing a portion of the Stream Z buffer width below the standard 50-foot buffer for a Type III stream required per PMC 21.06.1050(2). Work within the modified critical area buffers will be limited to the utility crossings of the Stream Z buffer necessary to connect to existing infrastructure, the relocation of a power pole within the Stream Z buffer necessary to support required frontage improvements along East Pioneer Avenue, work necessary to provide site access from East Pioneer Avenue, and the work needed to maintain site drainage patterns. Stormwater discharge locations are proposed to be located landward of OHW.

During Phase II of the project, required frontage improvements and the proposed stream crossing for site access cannot avoid critical area impacts. Given the location of Stream Z within the existing right-of-way (ROW) of East Pioneer Avenue, shifting Stream Z south is also necessary and unavoidable to provide updated sidewalk, curb gutters, and landscaping to meet current City requirements. Due to the shifting of Stream Z to the south, the proposed site layout will result in a variable buffer width along the new Stream Z channel that is less than the standard 50-foot buffer width for a Type III stream specified under PMC 21.06.1050(2).

Given the proposed mixed-use development with several apartment buildings and commercial space, one site access point from Shaw Road East is not practicable. Therefore, the existing crossing from East Pioneer Avenue will need to be upgraded and widened to provide safe site access for the new development; this site access will alleviate traffic issues by aiding in vehicle circulation and splitting use between two arterials and will also allow multiple access points for safety vehicles. PMC 21.06.1030(1) states that relocation of Type II, III, and IV streams are permitted when the action will result in equal or better habitat and water quality and will not diminish the flow capacity of the stream; the mitigation actions described herein demonstrate how the project is anticipated to increase ecological functions when compared to the existing degraded conditions of the streams.

The project avoids direct impacts and take of listed threatened or endangered species per PMC 21.06.1020(4) as no threatened or endangered species are present in the project area.

b) Minimizing impacts by limiting the degree or magnitude of the action and its implementation.

During Phase I, the proposed project has minimized impacts by avoiding in-water work, locating buildings and parking areas outside of modified buffer widths for the existing stream alignments and incorporating an underground stormwater vault that avoids the need for an above ground detention facility.

The site plan has also been revised to reduce the number of proposed parking stalls and relocated two buildings in proximity to Stream Z, reducing stream buffer impacts and allowing for and increased buffer width between Stream Z and the proposed development during Phase II. During Phase II, the proposed direct impacts to Stream Z are the minimum necessary to provide the required frontage improvements and upgrade the existing crossing from East Pioneer Avenue for safe site access. The upgraded crossing will consist of a bottomless, fish-passable, culvert. To

accommodate future potential fish passage along Stream Z at the request of WDFW, the project proposes to install a box culvert to connect the new Stream Z channel to the existing downgradient piped Stream Z. Appropriate BMPs and TESC measures will be implemented for the duration of project activities to minimize potential construction impacts. The stream relocation work will be completed in the dry season when hydrology is either absent or minimal to limit temporary turbidity.

c) *Rectifying impacts by repairing, rehabilitating, or restoring the affected environment.*

During Phase I, the proposed project will rectify the temporary Stream Z buffer impacts by replanting temporarily impacted areas with a native seed mix. To rectify the proposed Stream Z buffer decrease below standard buffer width, the project proposes to add additional buffer area to provide an equivalent buffer area as the standard buffer required per PMC 21.06.1050(2). The proposed modified stream buffers consist of 866 square feet of Stream Z buffer decrease and 1,030 square feet of Stream Z increase.

To offset the necessary and unavoidable direct impacts to Stream Z during Phase II, the project proposes to restore and realign Stream Z within a reestablished riparian corridor on the northern portion of the project area. In the existing linear, ditched alignment, Stream Z is extremely degraded as the system lacks riparian cover, habitat complexity, and floodplain function and is situated in a roadside ditch with several piped segments. The proposal will provide a protected riparian corridor with a highly functional stream with large woody debris, flood benches, and dense riparian plantings that will all increase the complexity and functionality of the stream system. In addition, the Applicant proposes to voluntarily restore Stream Y to a new, offsite stream channel near the east property boundary and to enhance and restore the surrounding buffer during Phase II. In its existing alignment, Stream Y is diverted into a stormwater pond and then piped for approximately 471 feet before discharging into Stream Z along East Pioneer Avenue. Therefore, in its current alignment, Stream Y is extremely degraded and daylighting and creating a new stream channel will increase stream habitat availability and functions. The restored stream channels are proposed to be protected by 74,796 square feet of buffer, exceeding the buffer area that would result from a standard application of a 35-foot buffer to a Type IV stream and 50-foot buffer to a Type III stream by 14,566 square feet.

The mitigation plan will provide a comprehensive stream restoration approach with watershed-level benefits to significantly increase stream functions of two tributaries that drain to Upper Deer Creek approximately 0.25-mile offsite to the west. Upper Deer Creek drains to the Puyallup River and is a gradient accessible stream for coho, Chinook, chum, pink and steelhead and also has known trout populations. In addition, Upper Deer Creek has documented water quality issues due to the 4A listing for high levels of bacteria from fecal coliform. Downgradient of the site, the Puyallup River also has documented water quality issues due to the 303d listings for high levels of bacteria from fecal coliform, high water temperatures, and high levels of mercury; these 303d listings resulted in the development of Puyallup River Watershed Fecal Coliform Total Maximum Daily Load (TMDL) Water Quality Report and Implementation Plan (WSDOE, 2011). The Puyallup River TMDL identifies Deer Creek in the Shaw Road area near the project site as an ideal area to restore riparian habitat. Further, both streams are within mapped FEMA 100-year floodplain but currently provide de minimis flood functions due to the straightened, ditched conditions. Restoring stream and riparian habitat will improve usable fish habitat within Stream Z over time, increase sediment and pollutant filtration to improve documented water quality

issues, and provide flood benches to increase hydrologic functions and flow capacity that will reduce local flooding. Therefore, the project is aligned with the Puyallup River TMDL, will result in equal or better habitat and water quality per PMC 21.06.1030(1), and is anticipated to result in a net gain in ecological functions in the watershed per PMC 21.06.1080(3) when compared to the existing degraded conditions of the stream that will be impacted from the frontage improvements and upgraded crossing.

d) *Reducing or eliminating an impact over time by preservation and maintenance operations during the life of the action.*

The stream restoration areas created during Phase II will be monitored for a period of up to 10 years to ensure success of the mitigation actions over time. In addition, the mitigation areas will be placed in a separate tract or dedicated to the City as a permanent protective mechanism per PMC 21.06.610(7) and PMC 21.06.830. Fencing and signage will also be provided per PMC 21.06.810 to reduce intrusion into the critical areas and prevent future impacts to the critical areas.

e) *Compensating for an impact by replacing or providing substitute resources or environments.*

See response to criterion C above. During Phase I, the proposed Stream Z buffer decrease will be compensated through the addition of buffer area. During Phase II, the unavoidable direct stream impacts will be compensated through onsite and offsite, in-kind stream creation mitigation measures. The project will ensure no net loss of area under PMC 21.06.1080(3) and PMC 21.06.610(2) by providing buffer enhancement and a minimum 1:1 ratio of creation to impacts to achieve equivalent or greater functions for Stream Z per PMC 21.06.1080(2). The mitigation will result in no net loss of ecological functions when compared to the existing degraded condition of the stream proposed to be impacted.

f) *Monitoring the mitigation and taking remedial action when necessary.*

The stream mitigation and voluntary restoration areas created during Phase II will be monitored for a period of 10 years to ensure success of the actions over time, consistent with PMC 21.06.630. Appropriate contingency measures will be implemented if monitoring indicates that goals and performance standards of the mitigation plan are not being met.

1.1.3 Performance Standards – Alteration of Streams and Riparian Habitats

PMC 21.06.1030 outlines standards for allowed alterations to streams and associated riparian habitats. Necessary and unavoidable stream impacts are required for frontage improvements, upgrading an existing crossing from East Pioneer Avenue for additional site access, and providing power to the property.

PMC 21.06.1030(2) states the following for proposed bridges/culverts:

Bridges are the preferred crossing for fish-bearing streams. Culverts are allowed only in Type II, III, and IV streams; provided, that they are designed according to the Washington Department of Fish and Wildlife criteria for fish passage, are necessary for utility crossings, road crossings, or other limited access situations, and are in accordance with a state Hydraulic Project Approval permit. The applicant or property owner shall keep any culvert free of debris and sediment at all times to allow free passage of water and, if applicable, fish. The city may require that a stream be removed from a culvert as a condition of approval, unless the culvert is not detrimental to fish habitat or water quality, or removal would be detrimental to fish or wildlife habitat or water quality.

The proposed crossing will be in accordance with the most recent WDFW crossing design criteria for fish passage, and the Applicant will apply for a Hydraulic Project Approval (HPA) from WDFW. The crossing is essential for providing necessary site access. Having two site access points is required by City development standards and will alleviate traffic issues by aiding in vehicle circulation and splitting use between two arterials and will also allow multiple access points for safety vehicles. The new/upgraded crossing will be bottomless to allow free passage of water. The bottomless crossing will be monitored to ensure that it functions as intended over time.

PMC 21.06.1030(6) states that utility lines may be permitted to cross streams and riparian habitat areas subject to the following standards:

- a) *Impacts to fish and wildlife shall be avoided to the maximum extent possible;*

The proposed utility installations are necessary to connect to existing infrastructure and to maintain existing site drainage patterns. In addition, the relocation of an existing power pole adjacent to Stream Z further within the stream buffer is necessary to support frontage improvements. During Phase I, the project proposes to install a new power drop, consisting of a transformer box and electrical line within the existing Stream Z buffer. The new power drop will connect to an existing power line along East Pioneer Avenue; the proposed transformer box and electrical line will be located as near to an existing power pole as feasible to minimize the length of electrical line in the buffer. As documented in the Conceptual Mitigation Plan dated April 7, 2023, the project previously proposed to install a stormwater line in the Stream Z buffer during Phase I to connect to an existing pipe adjacent to East Pioneer Avenue using a manhole. The proposed stormwater discharge from the site has been redesigned to avoid the manhole connection as requested by WDFW. The proposed stormwater discharge will release treated and detained runoff into the Stream Z buffer. The discharge infrastructure is anticipated to consist of temporary release points during Phase I that will be replaced with a permanent discharge infrastructure during Phase II. The power pole proposed to be relocated is an existing impact within the stream buffer and will result only in new temporary impacts that will be fully restored.

- b) *Installation shall be accomplished by boring beneath the scour depth and hyporheic zone of the water body and channel migration zone, where feasible;*

The proposed stormwater discharge location and power pole relocation will be located landward of the Stream Z OHW. The proposed transformer box will be located within the existing Stream Z buffer; the proposed electrical line will cross a piped section of the existing and proposed Stream Z alignments. Due to the presence of piped stream sections, boring beneath the scour depth and hyporheic zone of the water body is not applicable.

- c) *The utilities shall cross at an angle greater than 60 degrees to the centerline of the channel in streams or perpendicular to the channel centerline whenever boring under the channel is not feasible;*

No stormwater crossing of the stream channel is proposed. The proposed transformer box and relocated power pole will be located within the existing Stream Z buffer; the proposed electrical line will cross a piped section of the existing and proposed Stream Z alignments.

- d) *Crossings shall be contained within the footprint of an existing road or utility crossing where possible;*

The proposed stormwater discharge location has been revised as requested by WDFW to avoid a manhole connection to an existing pipe conveying Stream Z waters downgradient of the site. The proposed stormwater discharge location will be located landward of the Stream Z OHW and is designed to maintain existing site drainage patterns given the site grading.

No power crossings currently existing along East Pioneer Avenue and crossing location is limited by the proximity of adjacent power poles.

- e) *The utility route shall avoid paralleling the stream or following a down-valley course near the channel where feasible; and*

The proposed stormwater discharge and electric utilities will be perpendicular to the stream to the extent feasible. In addition, the existing buffer conditions are degraded and temporary impacts are proposed to be restored using a native seed mix.

- f) *The utility installation shall not increase or decrease the natural rate of channel migration.*

The proposed utility crossings will not disturb the new stream channel and will not increase or decrease the rate of channel migration.

1.2 State Considerations

The identified streams and offsite wetland are also likely to be regulated as natural surface waters by the WSDOE under the Revised Code of Washington (RCW) 90.48.

RCW 77.55 requires that in-water work requires Hydraulic Project Approval (HPA) from WDFW. WDFW conducted a joint site investigation with SVC on July 19, 2023. During the joint site investigation, WDFW determined that Streams Z and Y were Type F (fish habitat) streams based on the field observations and prior WDFW fish passage inventory assessment notes.

1.3 Federal Considerations

On January 18, 2023, USACE and EPA published a revised definition of “Waters of the United States.” The revised rule becomes effective on March 20, 2023. Under the 2023 revised rule, Waters of the United States is described as follows (USACE and EPA, 2023):

(a) Waters of the United States means:

(1) Waters which are: (i) Currently used, or were used in the past, or may be susceptible to use in interstate or foreign commerce, including all waters which are subject to the ebb and flow of the tide; (ii) The territorial seas; or (iii) Interstate waters, including interstate wetlands;

(2) Impoundments of waters otherwise defined as waters of the United States under this definition, other than impoundments of waters identified under paragraph (a)(5) of this section;

(3) Tributaries of waters identified in paragraph (a)(1) or (2) of this section: (i) That are relatively permanent, standing or continuously flowing bodies of water; or (ii) That either alone or in combination with similarly situated waters in the region, significantly affect the chemical, physical, or biological integrity of waters identified in paragraph (a)(1) of this section;

(4) Wetlands adjacent to the following waters: (i) Waters identified in paragraph (a)(1) of this section; or (ii) Relatively permanent, standing or continuously flowing bodies of water identified in paragraph (a)(2) or (a)(3)(i) of this section and with a continuous surface connection to those waters; or (iii) Waters identified in paragraph (a)(2) or (3) of this section when the wetlands either alone or in combination with similarly situated waters in the region, significantly affect the chemical, physical, or biological integrity of waters identified in paragraph (a)(1) of this section;

(5) Intrastate lakes and ponds, streams, or wetlands not identified in paragraphs (a)(1) through (4) of this section: (i) That are relatively permanent, standing or continuously flowing bodies of water with a continuous surface connection to the waters identified in paragraph (a)(1) or (a)(3)(i) of this section; or (ii) That either alone or in combination with similarly situated waters in the region, significantly affect the chemical, physical, or biological integrity of waters identified in paragraph (a)(1) of this section.

Wetland 1 appears hydrologically connected to Stream Y. Streams Y and Z are relatively permanent tributaries that discharge into Upper Deer Creek and eventually the Puyallup River, a traditional navigable water. Therefore, the identified critical areas are likely jurisdictional under the Clean Water Act. The project proposal assumes that the USACE will assert jurisdiction over the identified streams and wetland. On May 25, 2023, the U.S. Supreme Court issued a decision affecting the definition of Waters of the United States in *Sackett Et Ux. V Environmental Protection Agency Et Al*. While USACE is in receipt of the Supreme Court decision, no formal, revised definition of Waters of the United States has been issued at the time of this report drafting. The proposed project therefore continues to assume that the identified streams and wetland are considered Waters of the United States.

Chapter 2. Conceptual Mitigation Plan

The proposed compensatory mitigation actions for the project attempt to strike a balance between achieving project goals as well as a positive ecological result. In general, joint USACE and EPA rules have been established that require more careful mitigation planning efforts utilizing a watershed approach in site selection (USACE & EPA, 2008). The proposed impacts and mitigation actions attempt to closely adhere to these rules and to the local critical areas regulations specified in PMC Chapter 21.06 and local watershed planning and restoration documents. This chapter presents the mitigation details for the proposed mixed-use project.

The Applicant will submit any proposed substantial changes to the project or mitigation plan, such as significant changes to the amount, location, or design of mitigation; the goals, benchmarks, or performance standards; the monitoring or adaptive management provisions, to WSDOE for review and approval prior to implementation. Minor changes, such as alterations to the species listed in the planting plan, will be documented in the as-built report.

2.1 Purpose and Need

The purpose of the proposed project is to provide a mixed-use development that will help alleviate the shortage of housing in the greater Seattle area and expand the local economy by providing new services to the area through available commercial space.

2.2 Description of Impacts

The Applicant proposes a phased project to construct a mixed-use development. Phase I will include development of residential and commercial buildings, parking, utilities, stormwater infrastructure, and frontage improvements along Shaw Road East. Phase II of the project will implement the required frontage improvements along East Pioneer Avenue and expand the mixed-use development onsite. The proposed project has been carefully designed to avoid and minimize impacts to the greatest extent feasibly by utilizing the existing disturbed upland areas onsite. During Phase I, the proposed project will avoid in-water work and locate buildings and parking areas outside of modified buffers. Work within the critical area buffers will be limited to the utility crossings of the Stream Z buffer necessary to connect to existing infrastructure, the relocation of a power pole within the Stream Z buffer necessary to support required frontage improvements along East Pioneer Avenue, work necessary to provide site access from East Pioneer Avenue, and the work needed to maintain site drainage patterns. Stormwater discharge locations are proposed to be located landward of OHW. During Phase II of the project, required frontage improvements and the proposed Stream Z crossing for site access cannot avoid critical area impacts. Mitigation sequencing for the proposed project is provided under Section 1.1.2 Mitigation Sequencing.

Under Phase I, approximately 1,345 square feet of temporary impacts to the existing Stream Z buffer are proposed are anticipated to install the power drop, which will consist of a transformer box and electrical line, and to relocate an existing power pole adjacent to East Pioneer Avenue to support required frontage improvements.

Under Phase II, the project requires the complete fill and relocation of 592 linear feet of the Stream Z channel to provide City-required frontage improvements. A crossing of the proposed, realigned

Stream Z channel is required to provide safe site access, allow multiple points of access for emergency vehicles, and alleviate traffic congestion by aiding in vehicle circulation and splitting use between two arterials. Due to the realignment of Stream Z, the onsite buffer width for the new stream channel will be less than the standard 50-foot buffer for a Type III stream required per PMC 21.06.1050(2), resulting in 3,594 square feet of buffer decrease. The site plan has recently been revised to reduce the number of proposed parking stalls and relocate two buildings on the northwest portion of the subject property, minimizing the proposed buffer decrease. Temporary construction impacts may also occur but will be minimized to the greatest extent feasible with the implementation of all appropriate BMPs and TESC measures.

The Applicant proposes to voluntarily restore Stream Y within a new stream channel near the east property boundary and to enhance and restore a buffer surrounding the stream channel. The proposed beneficial realignment of Stream Y may also result in temporary stream impacts. Habitat Technologies previously described Stream Z and Stream Y as seasonal streams. The streams are tributaries to Deer Creek, which provides habitats for a number of fish species. However, prior assessments by Habitat Technologies and the Puyallup Tribe did not document fish utilization within the ditch system associated with the Pioneer Way East Corridor east of the confluence with Deer Creek (Habitat Technologies, 2022). During the joint site investigation with WDFW, WDFW characterized Streams Y and Z as Type F (fish habitat) streams.

2.2.1 Permanent Stream Impacts

In the existing linear, ditched alignment, Stream Z is extremely degraded as the system is situated in a roadside ditch with several piped segments and lacks riparian cover, habitat complexity, and floodplain function. The stream consists of one long run that lacks pool and riffle sequences. The stream along the majority of its length is choked with non-native, invasive reed canarygrass, which reduces water velocity and creates low levels of dissolved oxygen due to the stagnant conditions and die-off of vegetative material. The majority of the onsite stream channel will be permanently filled, and portions of the stream piped will be modified pre- and post-development based on frontage improvement requirements and existing conditions. The proposed stream relocation will result in a permanent loss of existing degraded habitat. Refer to Appendix C for photographs of Stream Z in its existing degraded condition.

A summary of impacted streams is provided in Table 1 below.

Table 1. Stream Impact Summary

Stream	City Type ¹	State Type ²	Impact Type	Impact Area
Z	Type III	Type F	Direct	592 LF

Notes:

1. Stream definitions per PMC 21.06.1010(3)(a) and Habitat Technologies (2021).
2. Stream typing per Washington Administrative Code (WAC) 222-16-030.

2.2.1 Temporary Stream Impacts

To minimize temporary impacts, stream relocation activities will occur in the summer during low stream flow or dry conditions. Dewatering activities associated with the realignment of Stream Z and restoration of Stream Y are not anticipated to significantly impact fish and other aquatic vertebrate

species potentially present in the channels at the time of construction given the timeline of construction in the summer months when hydrology is minimal and with all appropriate BMPs and TESC measures in place.

If water is present in the existing stream channels prior to realignment, then fish exclusion, capture and relocation actions and water quality monitoring actions will be implemented. Temporary turbidity increases within the new stream channels of Streams Y and Z are likely to occur during the rewatering of the new stream channels. Rewatering within the new channels is not anticipated to be completed in more than one segment for each stream separately. The Washington Administrative Code (WAC) 173-201A-200(1)(e) makes allowances for a temporary area of mixing during and immediately after in-water construction activities subject to the constraints of WAC 173-201A-400(4) and (6). For waters less than or equal to 10 cfs flow at the time of construction, the point of compliance shall be 100 feet downstream of the action. Water quality monitoring will be completed to evaluate compliance during rewatering, and fish exclusion nets will remain in place until suspended sediment levels match the point of compliance. The proposed fish exclusion and sediment controls are anticipated to lead to an avoidance or significant reduction in direct fish exposure to elevated suspended sediments if fish are present in the streams. A Water Quality Monitoring Plan has been prepared under separate cover. A Fish Protection and Exclusion Plan will be prepared under separate cover if requested by regulatory agencies.

2.3 Stream and Riparian Mitigation Strategy

2.3.1 Phase I

1,345 square feet of temporary impacts to the existing Stream Z buffer resulting from the power drop (e.g. transformer box and electric line) will be restored through reseeded of the existing degraded buffer using a native seed mix. 1,030 of Stream Z buffer area will be added to offset the impacts to 866 square feet of buffer.

2.3.2 Phase II

The compensatory mitigation actions outlined herein are intended to compensate for lost stream functions and values by providing an overall improvement in water quality, hydrologic, and habitat functions according to the needs of the site, local sub-basin, and overall Puyallup River watershed. The unavoidable direct stream impacts will be compensated through onsite and offsite, in-kind stream creation mitigation measures. The project will ensure no net loss of area under PMC 21.06.1080(3) and PMC 21.06.610(2) by providing a minimum 1:1 stream creation to impact ratio to achieve equivalent or greater Stream Z functions per PMC 21.06.1080(2) (Table 2). To offset the necessary and unavoidable direct impacts to Stream Z, the project proposes to restore and realign Stream Z within a reestablished riparian corridor on the northern portion of the project area. Voluntary restoration of Stream Y will occur through realignment of the stream through a new stream channel that is located immediately offsite adjacent to the eastern property boundary and buffer restoration and enhancement. 74,796 square feet of buffer enhancement and restoration is proposed to protect the realigned Streams Y and Z.

In the existing linear, ditched alignment, Stream Z is extremely degraded as the system lacks riparian cover, habitat complexity, and floodplain function and is situated in a roadside ditch with several piped segments. The proposal will provide a protected riparian corridor with a highly functional stream with

large woody debris, flood benches, and dense riparian plantings that will all increase the complexity and functionality of the stream system. In addition, the Applicant proposes to restore Stream Y to a new stream channel immediately offsite adjacent to the eastern property boundary and restore and enhance the stream buffer. In its existing alignment, Stream Y overflows into a stormwater pond and is then piped for approximately 471 feet before discharging into Stream Z along East Pioneer Avenue. The proposed realignment of Stream Y will daylight the stream, increasing functional stream habitat (Table 2). Table 2 quantifies the length and condition of stream segments onsite pre- and post-development.

Table 2. Summary of Stream Segments Pre- and Post-Development

Stream	City Type ¹	State Type ²	Condition	Existing	Proposed
Y	IV	F	Open Channel	110 LF	463 LF
			Culvert	471 LF	0 LF
			Total	581 LF	463 LF
Z	III	F	Open Channel	465 LF	475 LF
			Culvert	127 LF	138 LF
			Total	592 LF	613 LF

Notes:

1. Stream definitions per PMC 21.06.1010(3)(a) and Habitat Technologies (2021).
2. Stream typing per Washington Administrative Code (WAC) 222-16-030.

The mitigation plan will provide a comprehensive stream restoration approach with watershed-level benefits to significantly increase stream functions of two tributaries that drain to Upper Deer Creek approximately 0.25-mile offsite to the west. Upper Deer Creek drains to the Puyallup River and is a gradient accessible stream for coho, Chinook, chum, pink and steelhead and also has known trout populations. In addition, Upper Deer Creek has documented water quality issues due to the 4A listing for high levels of bacteria from fecal coliform. Downgradient of the site, the Puyallup River also has documented water quality issues due to the 303d listings for high levels of bacteria from fecal coliform, high water temperatures, and high levels of mercury; these 303d listings resulted in the development of Puyallup River Watershed Fecal Coliform Total Maximum Daily Load (TMDL) Water Quality Report and Implementation Plan (WSDOE, 2011). The Puyallup River TMDL identifies Deer Creek in the Shaw Road area near the project site as an ideal area to restore riparian habitat. Further, both streams are within mapped FEMA 100-year floodplain but currently provide de minimis flood functions due to the straightened, ditched conditions. Restoring stream and riparian habitat will improve usable fish habitat within the streams over time, increase sediment and pollutant filtration to improve documented water quality issues, and provide flood benches to increase hydrologic functions and flow capacity that will reduce local flooding. Therefore, the project is aligned with the Puyallup River TMDL, will result in equal or better habitat and water quality per PMC 21.06.1030(1), and is anticipated to result in a net gain in ecological functions in the watershed per PMC 21.06.1080(3) when compared to the existing degraded conditions of the stream that will be impacted from the frontage improvements and upgraded crossing.

“Pilot channels” will be created for the new Streams Z and Y that will naturally scour to create a sinuous stream with pool and riffle structure. Creating a pilot channel allows the stream to naturally form within the constructed bankfull width. The restored Stream Z channel will connect to the existing downgradient piped stream infrastructure with a box culvert. The restored stream channels will consist of meandering channels with connected flood terrace habitats within a riparian corridor containing native forest, shrub, and herbaceous plant communities. The stream creation will provide

gradual side slopes above the OHWM and created flood terraces. Large woody debris will be incorporated along the realigned and restored stream channels for additional habitat complexity and provide cover for aquatic wildlife. The proposed Stream Z and Stream Y upland buffers will also be restored and enhanced to provide sediment and pollutant filtration, reduction of surface flows, and habitat interspersions and complexity beneficial to urban fauna. Once established, the riparian habitat corridor will provide immediate and long-term benefits for terrestrial and aquatic wildlife and provide cool, clean, and clear water from the native plantings, which will increase stream shading, stormwater filtration, and wood recruitment as well as decreased streambank erosion.

The proposed native plant communities will be established according to location relative to the stream channels and topographic position within the remaining riparian corridor buffer areas. Tree and shrub plantings are proposed. Willows (*Salix* spp.) will dominate the banks of the stream channels to provide bank stability and shading. The proposed native species have been carefully selected according to indicator status and local vegetation observations to ensure the plants take root and thrive in the newly created riparian corridor. Given the limited space within the riparian corridor, smaller trees will be proposed to maximize use and plant quantities within the area to ensure dense screening and protections to Streams Y and Z. With establishment of the protective riparian corridor, fencing and signage around the entire sensitive areas tracts, and implementation of the required monitoring and maintenance actions, the mitigation areas are projected to be highly functional, persistent, and successful.

The proposed actions include, but are not limited to, the following:

- Install bottomless culvert crossing of the new Stream Z channel and box culvert to connect the new Stream Z channel to the existing piped stream infrastructure;
- Realign and restore Stream Z within a new riparian corridor;
- Realign and restore Stream Y within a new riparian corridor;
- Pre-treat invasive plants with an herbicide approved by the Washington State Department of Agriculture for use in aquatic areas. After pre-treatment, grub to remove the invasive plants and replant all cleared areas with native trees, shrubs, and ground covers listed in Appendix A; Pre-treatment of the invasive plants should occur a minimum of two weeks prior to removal;
- Replant all impacted areas with native trees, shrubs, and groundcovers listed in Appendix A, or substitutes approved by the responsible Project Scientist, to help retain soils, filter stormwater, and increase biodiversity;
- Install large woody debris habitat features within the realigned Stream Z channel and restored Stream Y channel;
- An approved native seed mix will be used to seed the disturbed mitigation areas after planting to reduce short-term erosion potential;
- Maintain and control invasive plants annually, at a minimum, or more frequently if necessary. Maintenance to reduce the growth and spread of invasive plants is not restricted to chemical applications but may include hand removal, if warranted;
- Provide dry-season irrigation as necessary to ensure native plant survival;
- Install split-rail fencing and critical area signage at the locations indicated in Appendix A;
- Store all construction equipment and materials outside of the critical areas and associated buffers;

- Direct exterior lights away from the streams and buffers wherever possible; and
- Place all activities that generate excessive noise (e.g., generators and air conditioning equipment) away from the streams and buffers where feasible.

2.4 Approach and Best Management Practices

Planting or seeding will occur immediately after grading is complete to the extent practicable. TESC measures will be implemented that consists of high-visibility fencing (HVF) installed around native vegetation along existing stream areas not proposed to be impacted, silt fencing between the graded areas and buffers, plastic sheeting on stockpiled materials, and seeding of disturbed soils. These TESC measures will be installed prior to the start of development or mitigation actions and actively managed for the duration of the project.

Equipment used will be typical for land clearing, grading, and excavation activities and will be kept in good working conditions and free of leaks. Equipment to be used will likely include excavators, backhoes, bulldozers, dump trucks, graders, et cetera. All equipment staging and materials stockpiles will be kept out of the critical areas and regulated buffers avoided by the proposed project, and the area will be kept free of spills and/or hazardous materials using a SPCCC prepared and implemented by the contractor. All clean fill material for site preparation will be sourced from upland areas onsite or from approved suppliers and will be free of pollutants and hazardous materials.

All equipment staging and materials stockpiles will be kept out of the identified critical areas and associated buffer areas, and the areas will need to be kept free of spills and/or hazardous materials. Construction materials along with all construction waste and debris will be effectively managed and stockpiled on paved surfaces and kept free of the critical areas and associated buffers. Following completion of the development, the entire site will be cleaned and detail graded using hand tools wherever necessary, and TESC measures will be removed.

Additional BMPs for the proposed in-water work are provided under separate cover in the Water Quality Monitoring Plan.

2.5 Mitigation Implementation

Compensatory mitigation and voluntary restoration actions will occur concurrently with the development of Phase II of the project. Initial actions will include excavation and grading required for Streams Z and Y realignment. Minor portions of the mitigation site may initially remain ungraded to ensure the separation of the proposed stream channels from the existing channels. Realignment of the streams should occur during the summer during low flow conditions and shall occur during in-water work windows approved by the regulatory agencies. Following the initial excavation and grading, native plants may be installed following consultation with the Project Scientist to determine feasibility given summer hydrology conditions. Streams Y and Z will then be realigned; minor excavation and grading work will be necessary in order to provide the connections between the new and existing stream channels. Native plants are anticipated to be fully installed during the fall or early winter (September 1– December 31) following the realignment of Streams Y and Z during the summer season. The mitigation site should be seeded prior to the beginning of the wet season to minimize erosion.

TESC measures will be implemented according to the TESC plan prepared for the proposed project. Typical TESC measures include silt fencing where appropriate to protect potential offsite critical areas, plastic sheeting on stockpiled materials, and seeding of disturbed soils which will be actively managed for the duration of the project.

The Project Scientist should be consulted prior and during the mitigation actions to ensure that mitigation actions are conducted according to the intent of the mitigation plan. The Project Scientist will inspect and approve the planting stock and review the planting plans with the landscaping contractor to ensure clear understanding of the plan prior to installation of plant materials. The Project Scientist will assist the landscape contractor in making any final adjustments in the planting schedule as needed, in response to field conditions.

The proposed actions will include the excavation of material to create the new Stream Z and Stream Y channels. Mitigation and restoration actions may be completed separately from clearing and grading actions in the rest of the Project Area. The new stream channels will be entirely excavated prior to the stream relocation, with a berm left on the upstream end of each channel to prevent the streams from immediately diverting into the new channel. Large woody debris will be installed following channel excavation. Soil amendments will be installed as needed throughout the riparian corridor. The onsite soil amendments may be sourced from scraped topsoil. Imported topsoil or soil amendments may be used at the discretion of the landscape contractor.

Re-watering of the streams should occur during in-water work windows approved by regulatory agencies. If water is present in the stream channels immediately prior to the realignment, then nets will be installed at the upstream and downstream ends of existing stream sections to be de-watered and fish capture and relocation efforts will proceed as needed. The fish protection efforts will be completed using netting to capture fish and relocate them to non-impacted areas. The realigned stream channels will then be re-watered. Sediment control structures may be installed within the new stream channels to address water quality issues. The existing stream channels may be filled immediately following the re-watering of the realigned stream channels.

The project sequencing is anticipated to as follows:

- Pre-construction conferences and regulatory notifications;
- Pre-treatment of non-native invasive plant species;
- Install TESC measures;
- Remove debris and invasive plant material from the mitigation areas;
- Rough grade the stream restoration areas according to the approved grading plan;
- Remove existing culverts within the mitigation site, install new bottomless crossing;
- Rough grade inspection;
- Finish grade and prepare grounds for planting in all mitigation areas;
- Install LWD;
- Install streambed substrates;
- Install new box culvert connection between new Stream Z channel and existing, downgradient, piped Stream Z;
- Dewater existing stream channel and rewater new stream channel;
- Monitor site hydrology;

- Plant inspections;
- Install plant materials and seed disturbed soils for erosion control;
- Post-construction inspection and as-built survey; and
- Post-construction maintenance, monitoring, and annual reporting.

2.5.1 Pre-Construction Meetings and Post-Construction Inspection

Two pre-construction meetings are recommended to be held involving representatives from the Applicant, Project Manager or Contractor, and Project Scientist. The first pre-construction meeting should occur prior to commencement of mitigation actions, and the second meeting should occur onsite after construction staking has been placed by professional surveyors. The overall purpose of the first pre-construction meeting should be to discuss the primary intent of the stream relocation and regulatory requirements; identify points of contact; establish communication lines between the Project Scientist, Project Manager or Contractor and landscaping personnel; review project scheduling; and address any questions or issues associated with the mitigation plan. The overall purpose of the second pre-construction meeting should be to discuss project implementation, protection of onsite habitat, construction BMPs, and identify invasive species management actions.

Post-construction inspection of all mitigation areas will be necessary to verify the installation conforms to the approved plan. This post-construction inspection effort will occur after completion of the stream relocation and all appropriate seeding and planting actions. The post-construction inspection will be documented in an As-Built (Year 0) Report. Any significant changes to the mitigation design will also be coordinated with regulatory staff as specified in regulatory approvals and presented in the As-Built Report. During the post-construction inspection, the Project Scientist will identify and mark long-term monitoring plots and photographic stations in the field that represent representative conditions of the stream relocation and other mitigation areas. The long-term monitoring locations will be GPS located and included in the As-Built Report.

2.6 Goals, Objectives, and Performance Standards

The goals and objectives for the proposed onsite and offsite, in-kind mitigation actions are based on establishing and enhancing stream areas to compensate for the loss of stream areas. Non-compensatory mitigation actions are proposed to provide additional ecological benefits at the mitigation site. These non-compensatory mitigation actions include the replacement of one undersized culvert with an upgraded culvert to improve fish passage, and enhancement of all onsite buffer areas. In addition, the stream relocation will significantly improve overall habitat conditions. The goals and objectives of the proposed mitigation actions are as follows.

“Cover” is used in this Mitigation Plan to mean the proportion of the ground surface that is covered by vegetation when viewed from above. Native recruits will be utilized in assessing performance standards unless otherwise specified for a particular performance standard. Dead or dying plants may be replaced, and replacement plants may be utilized in assessing performance standards, unless otherwise specified for a particular performance standard.

Goal 1 – Compensate for the loss of 592 linear feet the existing Stream Z channel by realigning Stream Z.

Objective 1.1 – Create 613 linear feet of new Stream Z channel.

Performance Standard 1.1.1 – The new Stream Z channel will be created according to the final approved design and documented in the As-Built Report.

Performance Standard 1.1.2 – Large woody debris in the new Stream Z channel will be installed according to the final approved design and documented in the As-Built Report.

Goal 2 – Voluntarily restore 463 linear feet of Stream Y channel by restoring Stream Y into a new stream channel.

Objective 2.1 – Restore 463 linear feet of Stream Y channel.

Performance Standard 2.1.1 – The new Stream Y channel will be created according to the final approved design and documented in the As-Built Report.

Performance Standard 2.1.2 – Large woody debris in the new Stream Y channel will be installed according to the final approved design and documented in the As-Built Report.

Goal 3 – Establish and enhance 70,998 square feet (1.62 acres) of riparian buffers for the newly restored Streams Y and Z to protect the streams and to provide improvements in buffer functions over existing degraded buffer conditions.

Objective 3.1 – Establish 74,796 square feet (1.717 acres) of riparian buffer that is vegetated with native woody plant cover to create diverse horizontal and vertical vegetation structure and wildlife habitat.

Performance Standard 3.1.1 – In Year 1, survival of installed woody vegetation will be 100 percent in the riparian buffer areas.

Performance Standard 3.1.2 – Native woody plant species will cover at least 15 percent of the mitigation areas at the end of Year 2, 25 percent cover at the end of Year 3, 35 percent cover at the end of Year 5, 50 percent cover at the end of Year 7, and 65 percent by the end of Year 10.

Performance Standard 3.1.3 – In all monitoring years, the riparian buffer area will contain at least 2 species of native trees and 3 species of native shrubs.

Objective 3.2 – Effectively control and/or eliminate non-native invasive species in riparian buffer areas.

Performance Standard 3.2.1 – Non-native invasive plants will not make up more than 20 percent cover during all monitoring years. Non-native invasive plants are plants listed by the Washington State Noxious Weed Board.

Goal 4 – Protect stream processes and fish passage within the new Stream Z channel.

Objective 4.1 – Ensure the new bottomless culvert crossing of Stream Z and the new box culvert connection between the new Stream Z and the existing piped Stream Z allow for unobstructed flows.

Performance Standard 4.1.1 – The bottomless culvert crossing of Stream Z and the box culvert connection to the existing piped Stream Z will be installed according to the final approved design and documented in the As-Built Report.

Performance Standard 4.1.2 – Unobstructed streamflow conveyance through the bottomless culvert crossing of Stream Z will be observed in all monitoring years.

2.7 Plant Materials and Installation

2.7.1 Plant Materials

All plant materials to be used for the restoration actions will be nursery grown stock from a reputable, local source. Only native species are to be used; no hybrids or cultivars will be allowed. Plant material provided will be typical of their species or variety; if not cuttings they will exhibit normal, densely developed branches and vigorous, fibrous root systems. Plants will be sound, healthy, vigorous plants free from defects, and all forms of disease and infestation.

Container stock shall have been grown in its delivery container for not less than six months but not more than two years. Plants shall not exhibit rootbound conditions. Under no circumstances shall container stock be handled by their trunks, stems, or tops. Seed mixture used for hand or hydroseeding shall contain fresh, clean, and new crop seed mixed by an approved method. The mixture is specified in the plan set.

Fertilizer will be in the form of Agriform plant tabs or an approved like form. Mulch or coir rings may be installed around woody vegetation as determined to be necessary for plant survivability by the landscape contractor.

2.7.2 Plant Scheduling, Species, Density, and Location

Plant installation should occur as close to conclusion of clearing and grading activities as possible to limit erosion and limit the temporal loss of function provided by the onsite habitat. All plantings should occur between September 1 and May 1 to ensure plants do not dry out after installation, or temporary irrigation measures may be necessary. All plantings will be installed according to the procedures detailed in the following subsections and as outlined on the site plans in Appendix A.

2.7.3 Quality Control for Planting Plan

All plant material should be inspected by the landscape contractor or Project Biologist upon delivery. Plant material not conforming to the specifications above will be rejected and replaced by the landscape contractor. Rejected plant materials shall be immediately removed from the site.

The landscape contractor should provide the Project Biologist with documentation of plant material that includes the supplying nursery contact information, location of genetic source, plant species, plant quantities, and plant sizes.

2.7.4 Product Handling, Delivery, and Storage

All seed should be delivered in original, unopened, and undamaged containers showing weight, analysis, and name of manufacturer. This material should be stored in a manner to prevent wetting and deterioration. All precautions customary in good trade practice shall be taken in preparing plants for moving. Workmanship that fails to meet industry standards will be rejected. Plants will be packed, transported, and handled with care to ensure protection against injury and from drying out. If plants cannot be planted immediately upon delivery they should be protected with soil, wet peat moss, or in a manner acceptable to the Project Biologist. Plants and mulch not installed immediately upon delivery shall be secured on the site to prevent theft or tampering. No plant shall be bound with rope or wire in a manner that could damage or break the branches. Plants transported on open vehicles should be secured with a protective covering to prevent windburn.

2.7.5 Preparation and Installation of Plant Materials

The landscape contractor shall verify the location of all elements of the mitigation plan with the responsible Project Biologist prior to installation. The responsible Project Biologist reserves the right to adjust the locations of landscape elements during the installation period as appropriate. If obstructions are encountered that are not shown on the drawings, planting operations will cease until alternate plant locations have been selected by and/or approved by the Project Biologist.

Circular plant pits with vertical sides will be excavated for all container stock. The pits should be at least 2 times the width of the rootball, and the depth of the pit should accommodate the entire root system. Please refer to planting detail in Appendix A.

Broken roots should be pruned with a sharp instrument and rootballs should be thoroughly soaked prior to installation. Set plant material upright in the planting pit to proper grade and alignment. Water plants thoroughly midway through backfilling and add Agriform tablets or similar. Water pits again upon completion of backfilling. No filling should occur around trunks or stems. Do not use frozen or muddy mixtures for backfilling. Form a ring of soil around the edge of each planting pit to retain water and install a 3- to 4-inch layer of mulch around the base of each container plant if determined to be necessary by the landscape contractor.

Topsoil, mulch, compost, or other amendments may be installed to ensure plant survivability at the discretion of the landscape contractor.

2.7.6 Temporary Irrigation Specifications

While the native species selected for the habitat restoration actions are hardy and typically thrive in northwest conditions and the proposed actions are planned in areas with sufficient hydroperiods for the species selected, some individual plants might perish due to dry conditions. Therefore, irrigation or regular watering may be provided as necessary for the duration of the first two growing seasons while the native plantings become established. If used, irrigation will be discontinued after two growing seasons. Irrigation is recommended two times per week. Frequency and amount of irrigation will be dependent upon climatic conditions and may require more or less frequency watering than two times per week.

2.7.7 Invasive Plant Control and Removal

Invasive species to be removed include reed canarygrass and all listed noxious weeds. To ensure non-native invasive species do not expand following the habitat restoration actions, non-native invasive plants within the entire mitigation area will be pretreated with a root-killing herbicide approved for

use in aquatic sites (i.e., Rodeo) a minimum of two weeks prior to being cleared and grubbed from the restoration areas. A second application is strongly recommended in areas with dense cover of non-native, invasive species. The pre-treatment with herbicide should occur prior to all planned restoration actions, and spot treatment of surviving non-native invasive vegetation should be performed again each fall prior to senescence for a minimum of five years.

2.8 Maintenance & Monitoring Plan

Conceptual Maintenance and Monitoring Plans are described below in accordance with PMC 21.06.630 and anticipated conditions from other regulatory agencies. The Applicant is committed to compliance with the conceptual mitigation plan and overall success of the project. As such, the Applicant will continue to maintain the project, keeping the site free from non-native invasive vegetation and trash. Maintenance frequency may be altered depending on the success of the mitigation site as evaluated during the monitoring visits.

The mitigation actions will require continued monitoring and maintenance to ensure the mitigation actions are successful. Therefore, the mitigation site will be monitored for a period of 10 years with formal inspections by a qualified Project Scientist. An As-Built (Year 0) inspection will occur within 30 days of the completion of plant installation. The maintenance/monitoring period will begin upon completion of an as-built plan and certification from the Project Scientist certifying the mitigation was installed per the mitigation plan. Formal monitoring events will be scheduled during Years 1, 2, 3, 5, 7, and 10. Close-out assessment will also be conducted in Year 10.

Monitoring will consist of percent cover measurements and stem counts at permanent monitoring stations, walk-through surveys to identify invasive species presence and dead or dying enhancement plantings, photographs taken at fixed photo points, wildlife observations, and general qualitative habitat and wetland function observations. Data collected during monitoring visits will be appropriate for the performance standards of the relevant monitoring year. The permanent monitoring stations will be established such that the mitigation site is representatively sampled. Circular sample plots, approximately 30 feet in diameter (706 square feet), will be centered at each monitoring station. Sample plots will be located entirely within the proposed mitigation site. Sample plot shapes may need to be adjusted to ensure that sample plots do not cross the mitigation site boundaries; adjusted sample plot shapes should maintain the same area as the 30-foot-diameter circular sample plots. Mean survivorship and percent cover measurements from the sample plots will be used to estimate survivorship and percent cover across the mitigation site.

To determine survivorship, individual tree and shrub stems within the relevant circular sampling plots will be counted. Plants which grow several stems from a single base will be counted as one individual plant. These trees and shrubs will then be recorded as dead/dying or alive. To determine percent cover and species richness of woody vegetation, each species of tree or shrub within the approximately 30-foot-diameter circular sampling plots will be recorded and identified as native or invasive. Plants may be recorded by genus if species is unable to be determined at the time of the monitoring visit. Herbaceous vegetation will be sampled from a 10-foot diameter (78.5 square feet), established at the same location as the center of each tree and shrub sample plot. Herbaceous vegetation within the sampling plot will be recorded to at least the genus level and identified as native or invasive. A list of observed tree, shrub, and herbaceous genera or species, cover estimates, and wetland indicator status will be included within each monitoring report.

Non-native, invasive plant control will be performed throughout the monitoring period. Plants listed by the Washington Noxious Weed Board will be controlled to meet applicable performance standards. Herbicide applications will be made in accordance with the Washington Department of Agriculture pesticide application procedures unless prohibited by the City of Puyallup. Herbicides will be herbicides approved by the Washington State Department of Agriculture for use in aquatic areas and will only be applied by a licensed applicator in aquatic areas.

2.9 Reporting

Following the implementation of the mitigation actions, the responsible Project Scientist will prepare an As-Built (Year 0) Report and will be submitted to the City of Puyallup's project manager and appropriate agencies within 90 days following the post-construction monitoring event. Following each monitoring event, a monitoring report detailing the current ecological status of the mitigation actions, measurement of performance standards, and management recommendations will be prepared and submitted to the City of Puyallup and appropriate agencies within 90 days of each monitoring event to ensure full compliance with the mitigation plan, performance standards, and regulatory conditions of approval. Per PMC 21.06.630(2), monitoring reports are only required annually for the first three years following construction and at least upon the completion of the last monitoring year.

2.10 Contingency Plan and Long-Term Management Plan

If monitoring results indicate that performance standards are not being met, it may be necessary to implement all or part of the contingency plan. Careful attention to maintenance is essential in ensuring that problems do not arise. Should any portion of the site fail to meet the success criteria, a contingency plan will be developed. Such plans are adaptive and will be prepared on a case-by-case basis to reflect the failed mitigation characteristics. Contingency plans can include additional plant installation, erosion control, and plant substitutions including type, size, and location. The contingency measures outlined below can also be utilized in perpetuity to maintain the streams and buffers associated with the proposed mitigation site.

This project proposes 10 years of monitoring for the mitigation actions in compliance with the goals and performance standards outlined in Section 2.6 of this report. However, the agencies may request additional years of monitoring and formal reporting if the site has not met the goals and performance standards by Year 10.

Contingency/maintenance activities may include, but are not limited to:

1. Using plugs instead of seed for emergent vegetation coverage where seeded material does not become well-established;
2. Replacing plants lost to vandalism, drought, or disease, as necessary;
3. Replacing any plant species with a 20 percent or greater mortality rate after two growing seasons with the same species or native species of similar form and function;
4. Irrigating the mitigation areas only as necessary during dry weather if plants appear to be too dry, with a minimal quantity of water;
5. Reseeding and/or repair of mitigation areas as necessary if erosion or sedimentation occurs;
6. Spot treat non-native invasive plant species, and
7. Removing all trash or undesirable debris from all mitigation areas as necessary.

2.11 Financial Assurances

Per PMC 21.06.650, a mitigation surety is required ensure that mitigation is fully functional. The Applicant will provide a performance bond and monitoring and maintenance bond in an amount equal to 125 percent of the total estimated fair market cost of mitigation actions. Per PMC 21.06.650, the mitigation surety shall be based on a detailed itemized cost estimate of the mitigation activity including clearing and grading, plant materials, plant installation, irrigation, weed management, and other costs. The bond quantity worksheet will be provided for the Final Mitigation Plan.

2.12 Critical Area Protection

The mitigation areas will be placed in a separate tract or dedicated to the City as a permanent protective mechanism per PMC 21.06.610(7) and PMC 21.06.830. Critical area tracts shall be designated as native growth protection areas and shall be recorded on all documents of title of record for all affected lots and will be designated on the face of the plat or recorded drawing. Fencing and signage will also be provided per PMC 21.06.810 to reduce intrusion into the critical areas and prevent future impacts to the critical areas.

Chapter 3. Closure

The findings and conclusions documented in this report have been prepared for specific application for the East Town Crossing project. These findings and conclusions have been developed in a manner consistent with that level of care and skill normally exercised by members of the environmental science profession currently practicing under similar conditions in the area. The conclusions and recommendations presented in this assessment report are professional opinions based on an interpretation of information currently available to us and are made within the operation scope, budget, and schedule of this project. No warranty, expressed or implied, is made. In addition, changes in government codes, regulations, or laws may occur. Due to such changes, our observations and conclusions applicable to this assessment may need to be revised wholly or in part in the future.

Chapter 4. References

- Barnard, R. J., J. Johnson, P. Brooks, K. M. Bates, B. Heiner, J. P. Klavas, D.C. Ponder, P.D. Smith, and P. D. Powers. 2013. *Water Crossings Design Guidelines*. Washington Department of Fish and Wildlife, Olympia, Washington. <http://wdfw.wa.gov/hab/ahg/culverts.htm>
- City of Puyallup. 2023a. Final Development Team Review Letter – Preliminary Site Plan for East Town Crossing. Prepared June 20, 2023.
- City of Puyallup. 2023b. Mitigated Determination of Non-Significance (MDNS). Prepared June 27, 2023.
- City of Puyallup. 2023c. Permit Review Correction Letter (Permit Application #PRCCP20230970). Prepared August 31, 2023.
- Habitat Technologies. 2021. *Wetland Delineation Report – East Town Crossing*. Prepared October 14, 2021.
- Habitat Technologies. 2022. *Stream Corridor Restoration and Enhancement Program – East Town Crossing*. Revised November 14, 2022.
- Hruby, T. 2014. *Washington State Wetland Rating System for Western Washington: 2014 Update*. (Publication #14-06-029). Olympia, WA: Washington Department of Ecology.
- John Comis Associates. 2020. *Verification Report for the Wetland & Stream Delineations at East Town Crossing for the Abbey Road Group*. Prepared March 24, 2020.
- U.S. Army Corps of Engineers (USACE) and U.S. Environmental Protection Agency (EPA). 2008. *Compensatory Mitigation for Losses of Aquatic Resources; Final Rule*. Federal Register. Volume 73, Number 70 (33 CFR Parts 325 & 332, 40 CFR Part 230)
- USACE. 2010. *Regional Supplement to the Corps of Engineers Wetland Delineation Manual: Western Mountains, Valleys, and Coast Region (Ver2.0)*, ed. J.S. Wakeley, R.W. Lichvar, and C.V. Noble. ERDC/EL TR-10-3. U.S. Army Engineer Research and Development Center. Vicksburg, Mississippi.
- Washington Department of Fish and Wildlife (WDFW) 2002. Integrated Streambank Protection Guidelines. Available at <https://wdfw.wa.gov/sites/default/files/publications/00046/wdfw00046.pdf> (accessed March 21, 2023).

Appendix A – Proposed Site Plan Exhibits

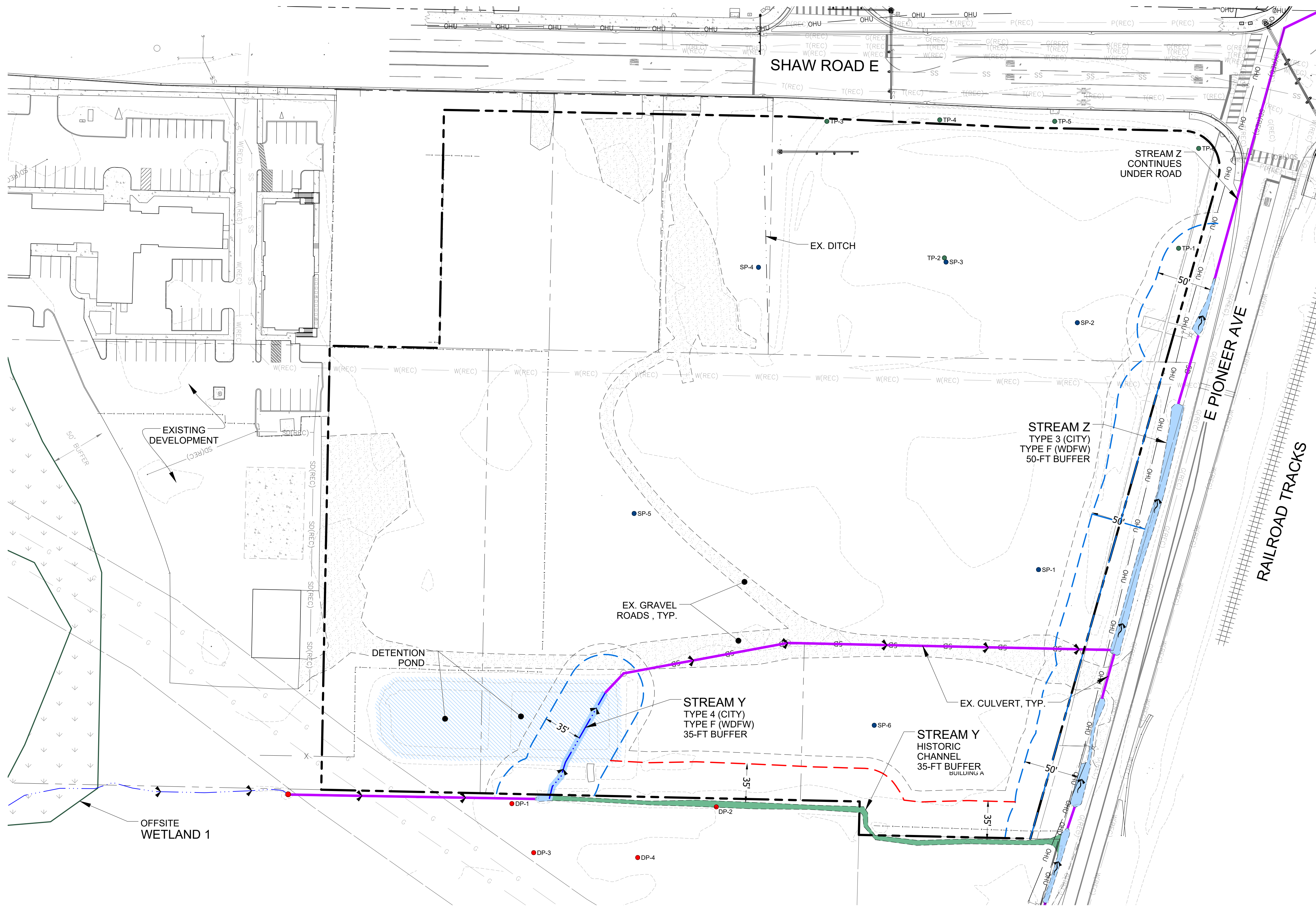

PLAN LEGEND

- DP-# PROPERTY LINE
- SP-# DATA PLOT LOCATION (SOUNDVIEW CONSULTANTS)
- TP-# DATA PLOT LOCATION (HABITAT TECHNOLOGIES 10/14/2021)
- TP-# DATA PLOT LOCATION (JOHN COMIS ASSOCIATES, LLC 3/24/2020)
- EXISTING STREAM CENTERLINE
- APPROXIMATE STREAM ORDINARY HIGH WATER LINE (SURVEYED TOE OF BANK)
- EXISTING STREAM BUFFER
- 10-FT BUILDING SETBACK
- EXISTING CULVERT
- HISTORIC STREAM ORDINARY HIGH WATER LINE (OHW)
- HISTORIC STREAM BUFFER
- DITCH CENTERLINE
- EXISTING 2-FT CONTOURS

STREAM LEGEND

	EXISTING
STREAM Y OPEN CHANNEL	110 LF (724 SF)
STREAM Y IN CULVERT	471 LF
STREAM Z OPEN CHANNEL	465 LF (3,009 SF)
STREAM Z IN CULVERT	127 LF

- NOTE**
- OFFSITE WETLAND 1 DELINEATION COMPLETED BY JOHN COMIS ASSOCIATES, LLC IN REPORT DATED MARCH 24, 2020.
 - CITY STREAM TYPING COMPLETED BY HABITAT TECHNOLOGIES IN REPORT DATED OCTOBER 14, 2021.
 - WDFW STREAM TYPING DETERMINED BY WDFW DURING JOINT SITE INVESTIGATION.

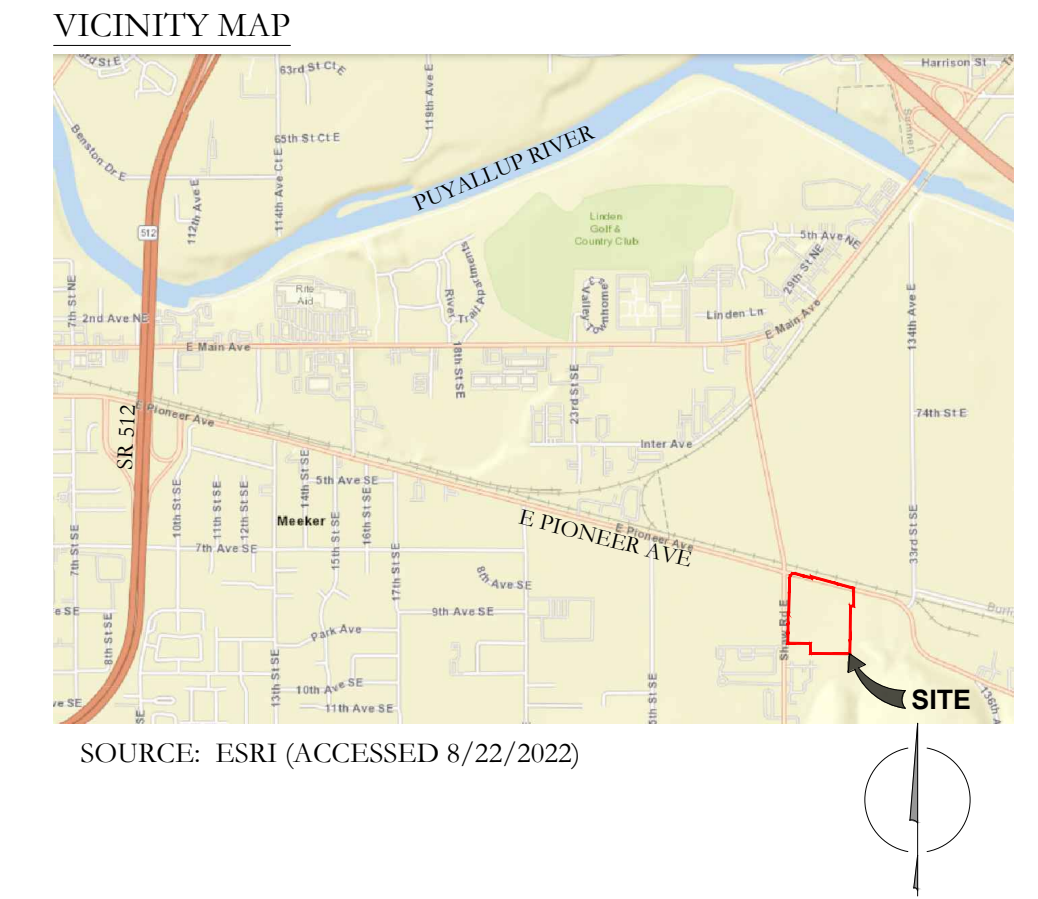

LOCATION

THE SE & NE ¼ OF SECTIONS 26 & 35,
TOWNSHIP 20N, RANGE 04E, WM

LAT: 47.184068° N LON: -122.254753° W
IN: PUYALLUP NEAR: ---

APPLICANT/OWNER

NAME: ASH DEVELOPMENT
ADDRESS: 1001 SHAW ROAD
PUYALLUP, WA 98371

CONTACT: GREG HELLE
PHONE: (253) 606-6799
E-MAIL: GREG.HELLE@ABSHERCO.COM

ENVIRONMENTAL CONSULTANT

SOUNDVIEW CONSULTANTS LLC
2907 HARBORVIEW DRIVE
GIG HARBOR, WA 98355
(253) 514-8952

SHEET INDEX

SHEET	SHEET TITLE
1.0	EXISTING CONDITIONS
2.0	PROPOSED SITE PLAN (PHASE I)

SOURCE:

TACOMA • SEATTLE • SPOKANE • TRI-CITIES
2215 North 30th Street, Suite 300 Tacoma, WA 98403
253.389.2422 TEL. 253.389.2572 FAX www.abbl.com WEB

Soundview Consultants
Environmental Assessment • Planning • Land Use Solutions
P. 253.514.8952
F. 253.514.8954
WWW.SOUNDVIEWCONSULTANTS.COM

2907 HARBORVIEW DRIVE
GIG HARBOR, WASHINGTON 98335
(253) 514-8952

EAST TOWN CROSSING
2902 E. PIONEER AVE.
PUYALLUP, WA 98374

PIERCE COUNTY PARCEL NUMBERS:
0420264021, 0420264053, 0420264054, 0420351030,
0420351029, 0420351026, & 0420351066

DATE: 3/14/2024
JOB: 2544.0001
BY: MW
SCALE: AS SHOWN
SHEET: 1.0

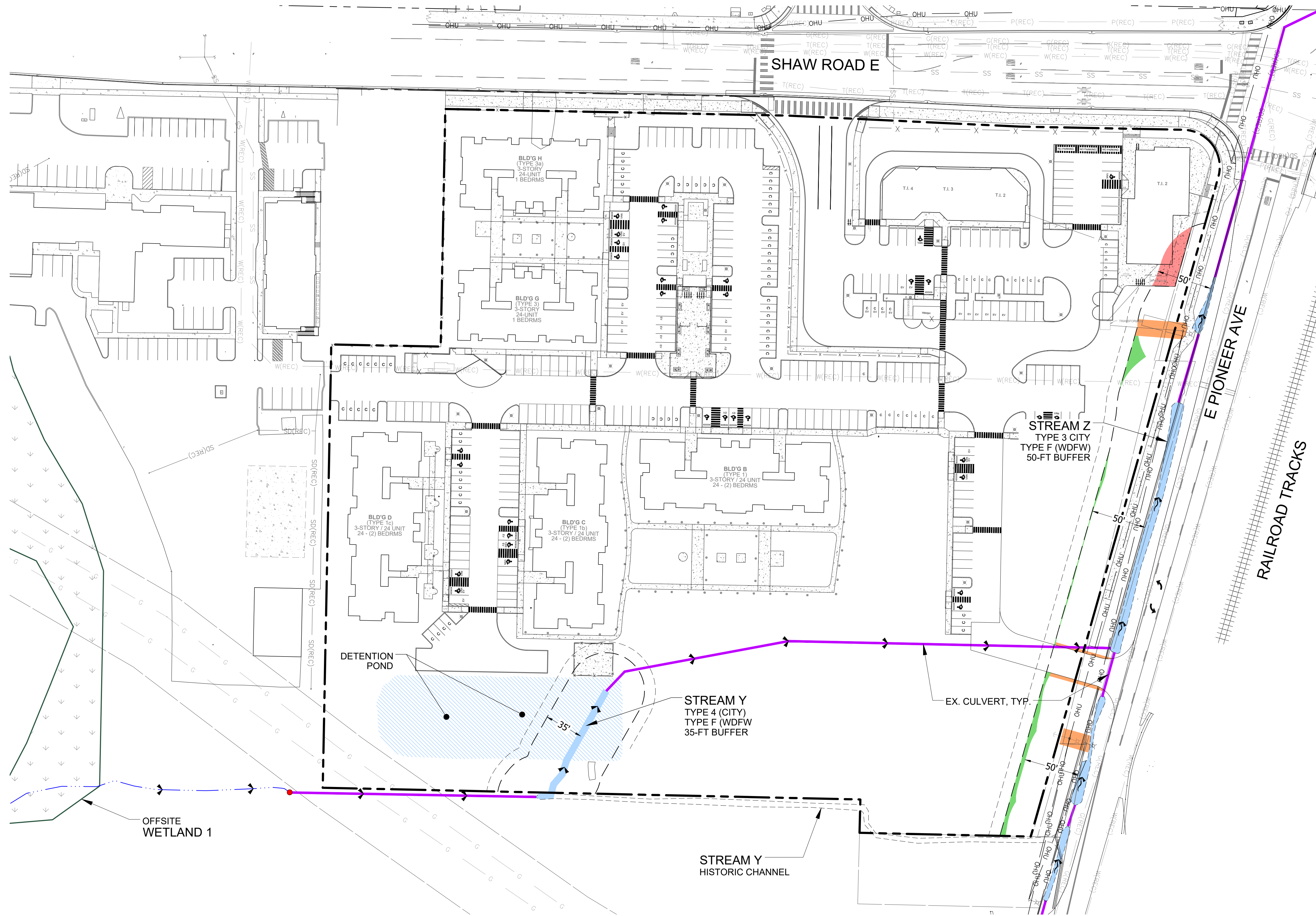

PLAN LEGEND

	PROPERTY LINE
	EXISTING STREAM CENTERLINE
	EXISTING STREAM ORDINARY HIGH WATER LINE (OHW)
	EXISTING CULVERT
	STREAM BUFFER
	10-FT BUILDING SETBACK

IMPACTS & MITIGATION LEGEND

TEMPORARY BUFFER AVERAGING

	STREAM BUFFER DECREASE	866 SF
	STREAM BUFFER INCREASE	1,030 SF
	NET BUFFER GAIN	164 SF

TEMPORARY GRADING IMPACTS

	STREAM BUFFER IMPACTS FOR DRIVEWAY & UTILITY INSTALLATION (TO BE RESTORED WITH NATIVE UPLAND GRASS SEED MIX)	1,345 SF
--	--------------------------------------------------------------------------------------------------------------	----------

PLANT SCHEDULE

SEED MIXES (www.riverrefugeseed.com)		Area (sf):	1,345
		WL Status	Buffer Plantings
Native Upland Grass Mix #9	20 lbs/acre		(Qty)
<i>Elymus glaucus</i>	Blue wildrye	30%	
<i>Bromus carinatus</i>	California brome	25%	
<i>Hordeum brachyantherum</i>	Meadow barley	10%	
<i>Festuca roemerii</i>	Roemer's fescue	10%	
<i>Deschampsia elongata</i>	Slender hairgrass	10%	
<i>Agrostis exarata</i>	Spike beargrass	5%	
<i>Deschampsia cespitosa</i>	Tufted hairgrass	5%	
<i>Festuca rubra var. rubra</i>	Red fescue	5%	
		Total (lbs):	1

1 - Scientific names and species identification taken from *Flora of the Pacific Northwest, 2nd Edition* (Hitchcock and Cronquist, Ed. by Giblin, Lodge, Zika, and Olmstead, 2018).

SOURCE:



TACOMA • SEATTLE • SPOKANE • TRI-CITIES
2215 North 30th Street, Suite 300 Tacoma, WA 98403
253.383.2422 TEL 253.383.2572 FAX www.aebl.com WEB

Soundview Consultants
Environmental Assessment • Planning • Land Use Solutions
P. 253.514.8952
F. 253.514.8954
WWW.SOUNDVIEWCONSULTANTS.COM



2907 HARBORVIEW DRIVE
GIG HARBOR, WASHINGTON 98335
WWW.SOUNDVIEWCONSULTANTS.COM

EAST TOWN CROSSING
2902 E. PIONEER AVE.
PUYALLUP, WA 98374
PIERCE COUNTY PARCEL NUMBERS:
0420264021, 0420264053, 0420264054, 0420351030,
0420351029, 0420351026, & 0420351066

DATE: 3/14/2024
JOB: 2544.0001
BY: MW
SCALE: AS SHOWN
SHEET: 2.0

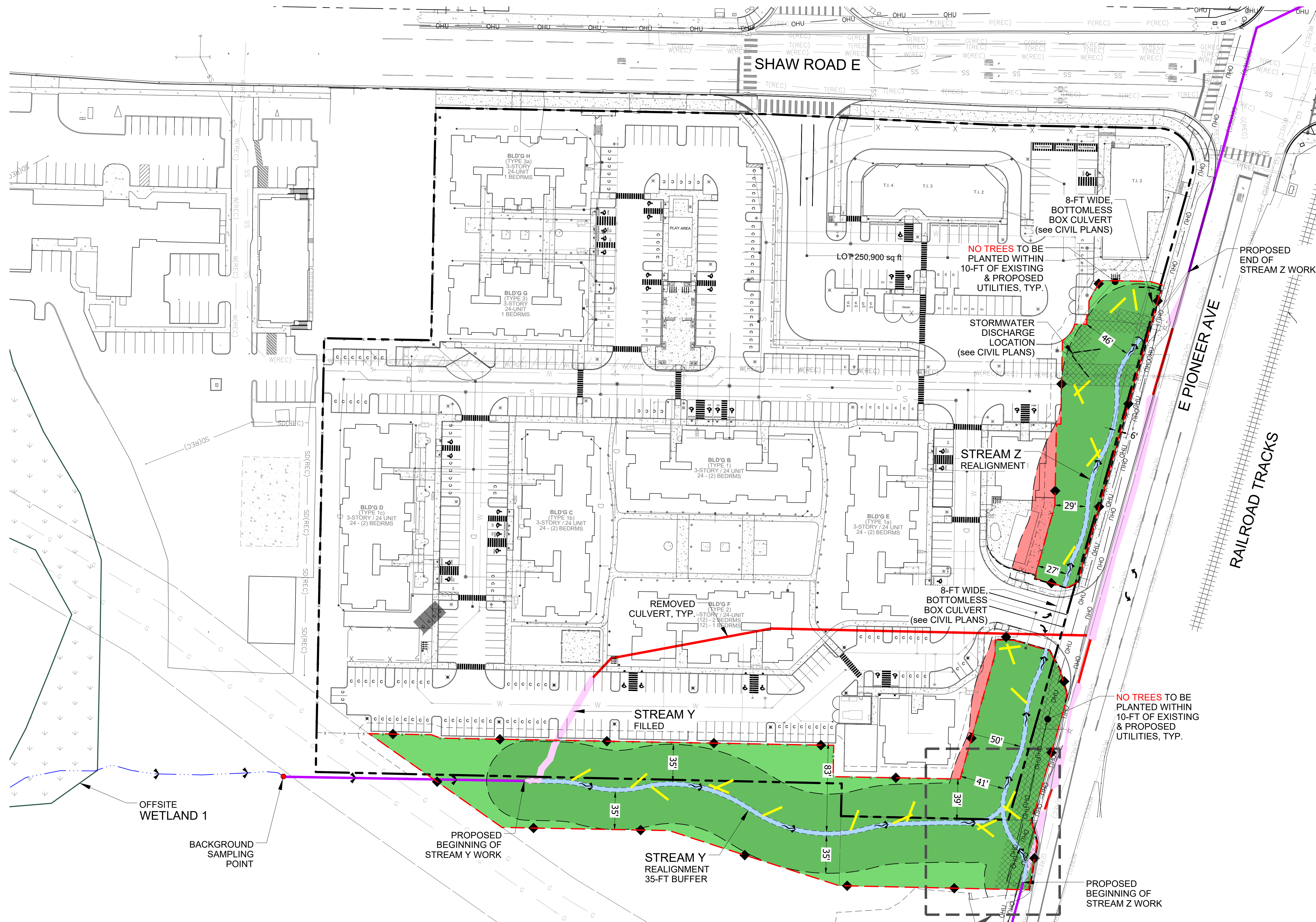

PLAN LEGEND

	PROPERTY LINE
	EXISTING STREAM CENTERLINE
	PROPOSED STREAM ORDINARY HIGH WATER LINE (OHW)
	STANDARD STREAM BUFFER
	EXISTING / RETAINED CULVERT
	PROPOSED CULVERT
	STREAM FILL
	REMOVED CULVERT

IMPACTS & MITIGATION LEGEND

	STREAM BUFFER DECREASE	3,594 SF
	STREAM BUFFER INCREASE	14,566 SF
	STREAM BUFFER RESTORATION/ENHANCEMENT (INCLUDES AREAS OF STREAM FILL WITHIN PROPOSED BUFFERS)	60,230 SF
	POST-CONSTRUCTION STREAM BUFFER/ CRITICAL AREA FENCE	
	10-FT BUILDING SETBACK	
	CRITICAL AREA SIGN (24 SIGNS)	
	LARGE WOODY DEBRIS (see SHEET 3.0)	

STREAM LEGEND

	EXISTING	PROPOSED
STREAM Y OPEN CHANNEL	110 LF (724 SF)	463 LF (1,836 SF)
STREAM Y IN CULVERT	471 LF	0 LF
STREAM Z OPEN CHANNEL	465 LF (3,009 SF)	475 LF (1,897 SF)
STREAM Z IN CULVERT	127 LF	138 LF

SOURCE:

AHBL

TACOMA • SEATTLE • SPOKANE • TRI-CITIES

2215 North 30th Street, Suite 300 Tacoma, WA 98403
253.388.2422 TEL 253.388.2572 FAX www.ahbl.com WEB

Soundview Consultants

Environmental Assessment • Planning • Land Use Solutions

P. 253.514.8952
F. 253.514.8954
WWW.SOUNDVIEWCONSULTANTS.COM

2907 HARBORVIEW DRIVE
GIG HARBOR, WASHINGTON 98335

EAST TOWN CROSSING

2902 E. PIONEER AVE.
PUYALLUP, WA 98374

PIERCE COUNTY PARCEL NUMBERS:
0420264021, 0420264053, 0420264054, 0420351030,
0420351029, 0420351026, & 0420351066

DATE:	3/14/2024
JOB:	2544.0001
BY:	MW
SCALE:	AS SHOWN
SHEET:	2.1

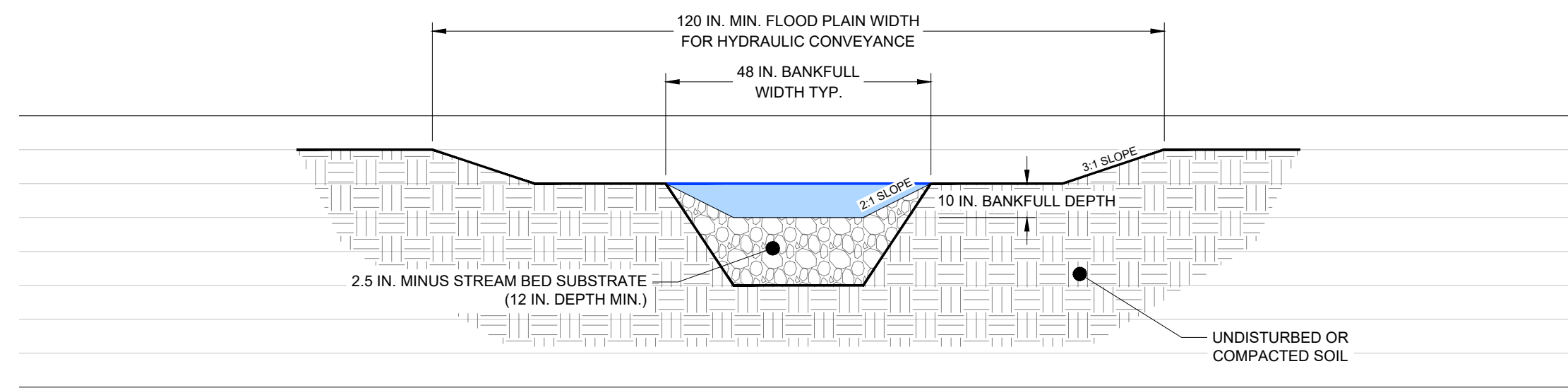

STREAMS Y & Z - PROPOSED CROSS SECTION, TYP.

SCALE: 1"=2'

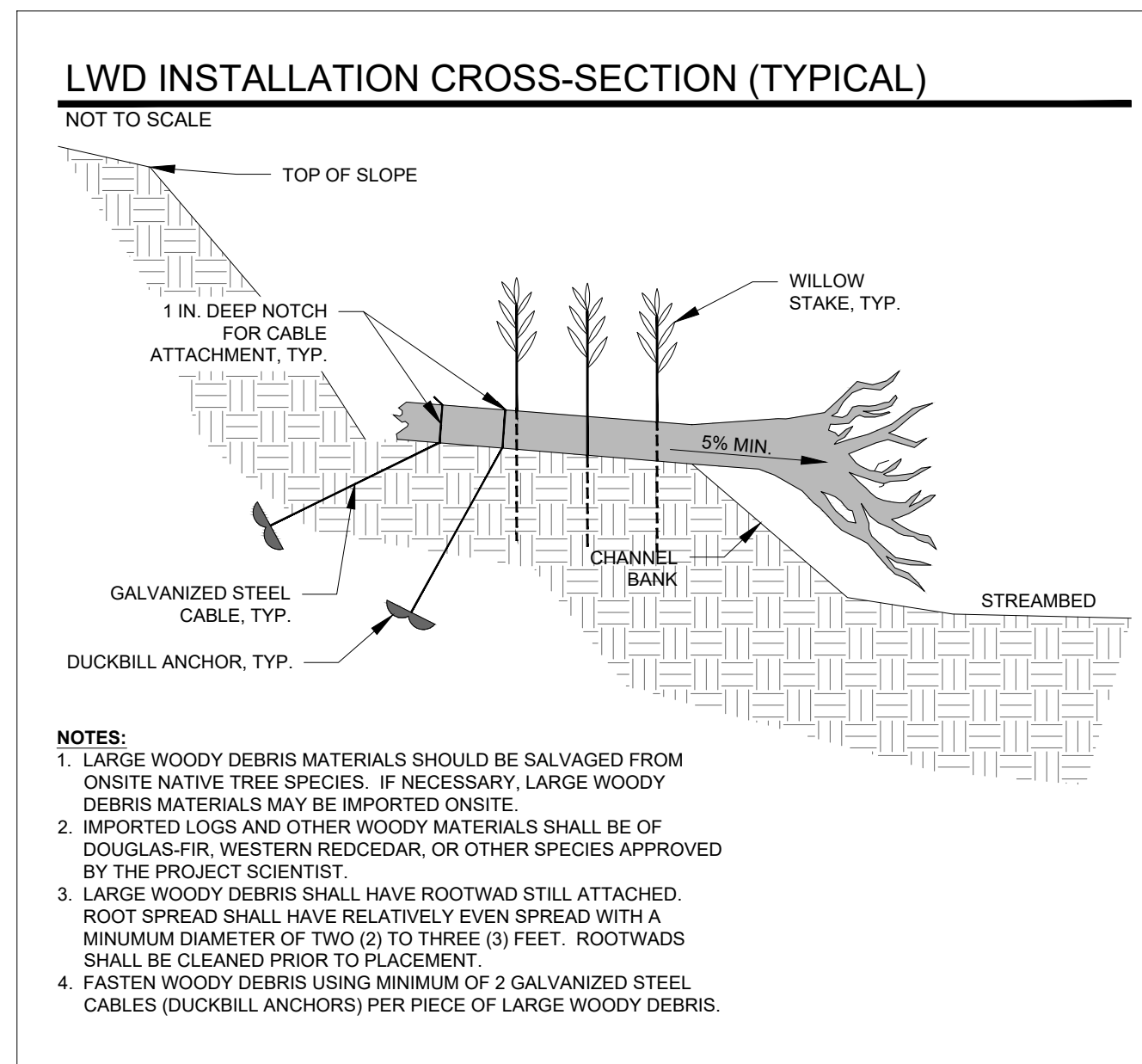

- NOTES:**
1. LARGE WOODY DEBRIS MATERIALS SHOULD BE SALVAGED FROM ONSITE NATIVE TREE SPECIES. IF NECESSARY, LARGE WOODY DEBRIS MATERIALS MAY BE IMPORTED ONSITE.
 2. IMPORTED LOGS AND OTHER WOODY MATERIALS SHALL BE OF DOUGLAS-FIR, WESTERN REDCEDAR, OR OTHER SPECIES APPROVED BY THE PROJECT SCIENTIST.
 3. LARGE WOODY DEBRIS SHALL HAVE ROOTWAD STILL ATTACHED. ROOT SPREAD SHALL HAVE RELATIVELY EVEN SPREAD WITH A MINIMUM DIAMETER OF TWO (2) TO THREE (3) FEET. ROOTWADS SHALL BE CLEANED PRIOR TO PLACEMENT.
 4. FASTEN WOODY DEBRIS USING MINIMUM OF 2 GALVANIZED STEEL CABLES (DUCKBILL ANCHORS) PER PIECE OF LARGE WOODY DEBRIS.

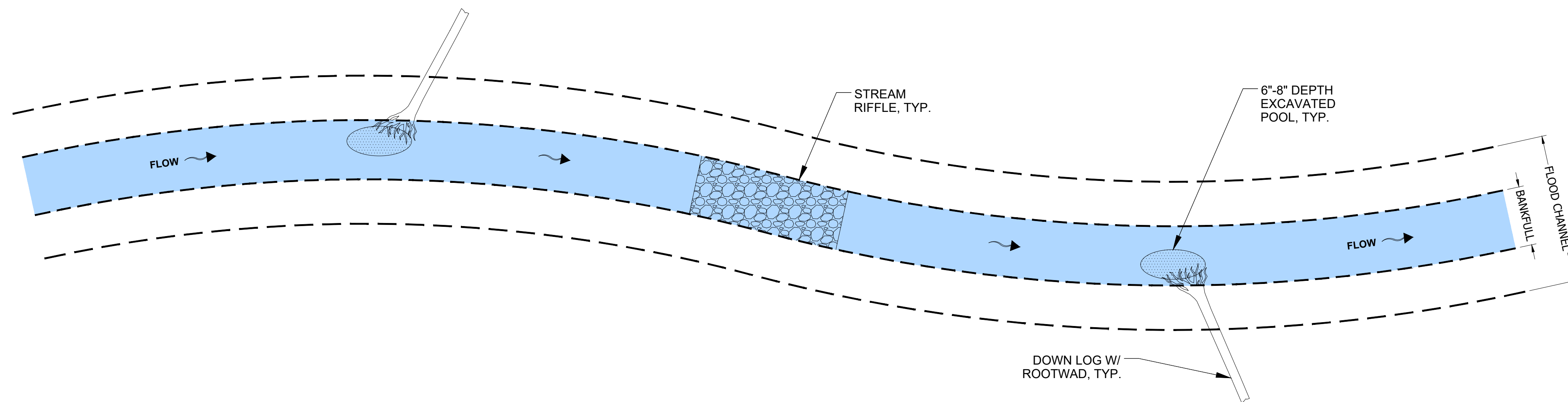

STREAMS Y & Z - PROPOSED PLAN VIEW, TYP.

SCALE: 1"=5'

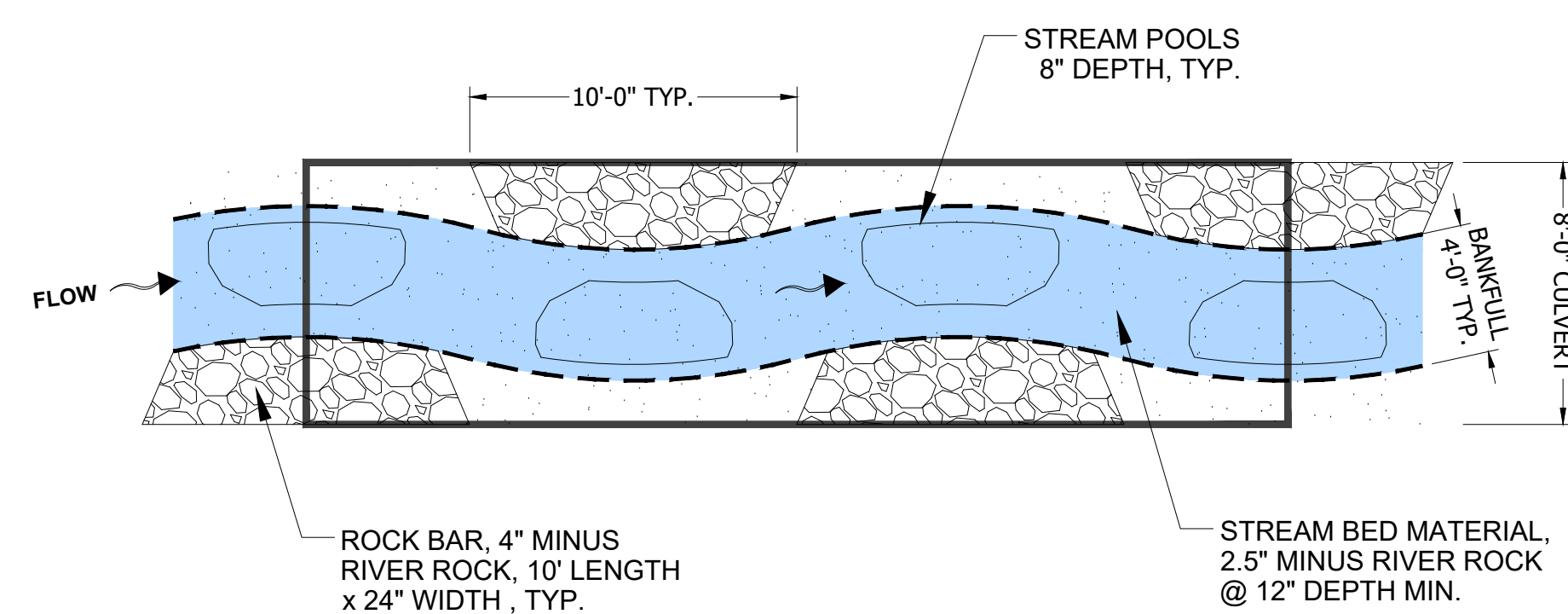

CULVERT DETAIL - PLAN VIEW, TYP.

SCALE: 1"=5'

SOURCE: **AHBL**
 TACOMA • SEATTLE • SPOKANE • TRI-CITIES
 2215 North 30th Street, Suite 300 Tacoma, WA 98403
 253.383.2422 TEL. 253.383.2572 FAX www.ahbl.com WEB

Soundview Consultants
 Environmental Assessment • Planning • Land Use Solutions
 P. 253.514.8952 F. 253.514.8954
 2907 HARBORVIEW DRIVE
 GIG HARBOR, WASHINGTON 98335
 WWW.SOUNDVIEWCONSULTANTS.COM

EAST TOWN CROSSING
 2902 E. PIONEER AVE.
 PUYALLUP, WA 98374
 PIERCE COUNTY PARCEL NUMBERS:
 0420264021, 0420264053, 0420264054, 0420351030,
 0420351029, 0420351026, & 0420351066

DATE:	3/14/2024
JOB:	2544.0001
BY:	MW
SCALE:	AS SHOWN
SHEET:	2,2

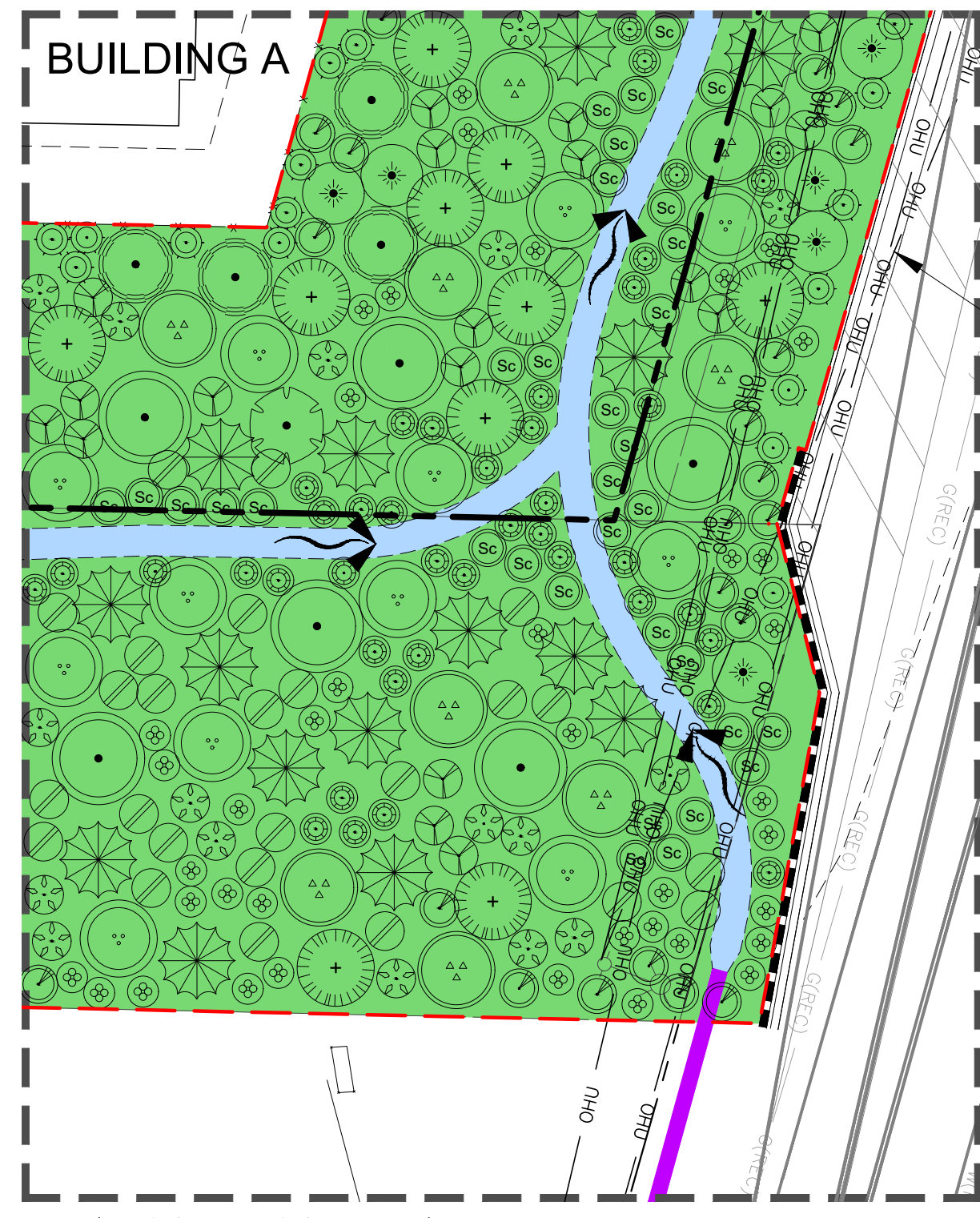

PLANTING TYPICAL
SCALE: 1"=20'

PLANT & HABITAT FEATURE SCHEDULE

Scientific Name	Common Name	Wl. Status	Area (sf): Cov'g (%): Trees (%): Shrubs (%):	Buffer Plantings	Spacing (min.)	Height (min.)	Size (min.)	Planting Area
TREES (Qty)								
<i>Acer macrophyllum</i>	bigleaf maple	FACU	74,796	36	10 ft	3 ft	2 gal	Dry
<i>Frangula purshiana (Rhamnus p.)</i>	cascara	FAC	100	6	10 ft	3 ft	1 gal	Dry
<i>Prunus emarginata</i>	bitter cherry	FACU	50	27	10 ft	3 ft	2 gal	Dry
<i>Pseudotsuga menziesii</i>	Douglas fir	FACU	50	54	10 ft	3 ft	2 gal	Dry
<i>Salix scouleriana</i>	Scouler's willow	FAC		216	5 ft	4 ft	Stakes	Dry
<i>Thuja plicata</i>	western redcedar	FAC		95	10 ft	3 ft	2 gal	Moist - on hummock
Total: 434 (Qty)								
SHRUBS								
<i>Acer circinatum</i>	vine maple	FAC		78	10 ft	4 ft	2 gal	Dry/Moist
<i>Amelanchier alnifolia</i>	serviceberry	FACU		31	8 ft	3 ft	2 gal	Dry
<i>Cornus stolonifera</i>	red-osier dogwood	FACW		173	4 ft	3 ft	1 gal	Moist/Wet
<i>Corylus cornuta var. californica</i>	western hazelnut	FACU		56	10 ft	2 ft	2 gal	Moist
<i>Holodiscus discolor</i>	oceanspray	FACU		133	5 ft	2 ft	1 gal	Dry
<i>Oemleria cerasiformis</i>	Indian plum	FACU		111	5 ft	2 ft	2 gal	Dry
<i>Polystichum munitum</i>	western swordfern	FACU		415	4 ft	1 ft	1 gal	Dry/Moist
<i>Rosa gymnocarpa</i>	bald hip rose	FACU		104	4 ft	2 ft	1 gal	Dry/Moist
<i>Rubus spectabilis var. spectabilis</i>	salmonberry	FAC		277	4 ft	2 ft	1 gal	Moist
<i>Sambucus racemosa var. racemosa</i>	red elderberry	FACU		111	5 ft	2 ft	2 gal	Dry
<i>Symphoricarpos albus var. laevigatus</i>	common snowberry	FACU		243	4 ft	2 ft	1 gal	Dry
Total: 1732								
SEED MIXES (www.riverrefugesseed.com)								
			Wl. Status	Buffer Plantings				
Native Upland Grass Mix #9			20 lbs/acre	(Qty)				
<i>Elymus glaucus</i>	Blue wildrye	30%						
<i>Bromus carinatus</i>	California brome	25%						
<i>Hordeum brachyantherum</i>	Meadow barley	10%						
<i>Festuca roemerii</i>	Roemer's fescue	10%						
<i>Deschampsia elongata</i>	Slender hairgrass	10%						
<i>Agrostis exarata</i>	Spike bentgrass	5%						
<i>Deschampsia cespitosa</i>	Tufted hairgrass	5%						
<i>Festuca rubra var. rubra</i>	Red fescue	5%						
			Total (lbs):	35				
Habitat Structures (Qty) Requirements								
Large Woody Debris	23 Pieces	For salvaged large woody debris: 35.31 cubic feet of large woody debris material minimum. For imported large woody debris: 12 foot length minimum, 10 inch diameter minimum, with 2-3 foot minimum diameter rootwad attached.						

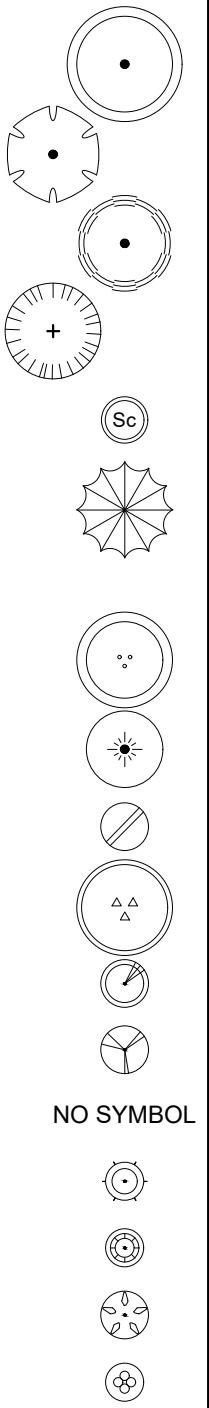

STREAMBED SUBSTRATE TABLE

STREAMBED SUBSTRATE SIZE	STREAM (REACH)	FEATURE	LENGTH (LF)	CROSS-SECTIONAL AREA OF GRAVEL (SF)	VOLUME OF GRAVEL (CF)
2.5 IN. MINUS	STREAM Y	CHANNEL & POOLS	463	2.98	1379.7
	STREAM Z	CHANNEL & POOLS	475	2.98	1415.5
				TOTAL 2.5 IN. MINUS GRAVEL (CF):	2795.2
				(CUBIC YARDS)	104
4 IN. MINUS	CULVERTS	ROCK BARS & POOLS	138	3	414.0
				TOTAL 4 IN. MINUS GRAVEL (CF):	414.0
				(CUBIC YARDS)	16

SOURCE:

TACOMA • SEATTLE • SPOKANE • TRI-CITIES
2215 North 30th Street, Suite 300 Tacoma, WA 98403
253.383.2422 TEL. 253.383.2572 FAX www.aebl.com WEB

Soundview Consultants
Environmental Assessment • Planning • Land Use Solutions
P. 253.514.8952
F. 253.514.8954
2007 HARBORVIEW DRIVE
GIG HARBOR, WASHINGTON 98335
WWW.SOUNDVIEWCONSULTANTS.COM

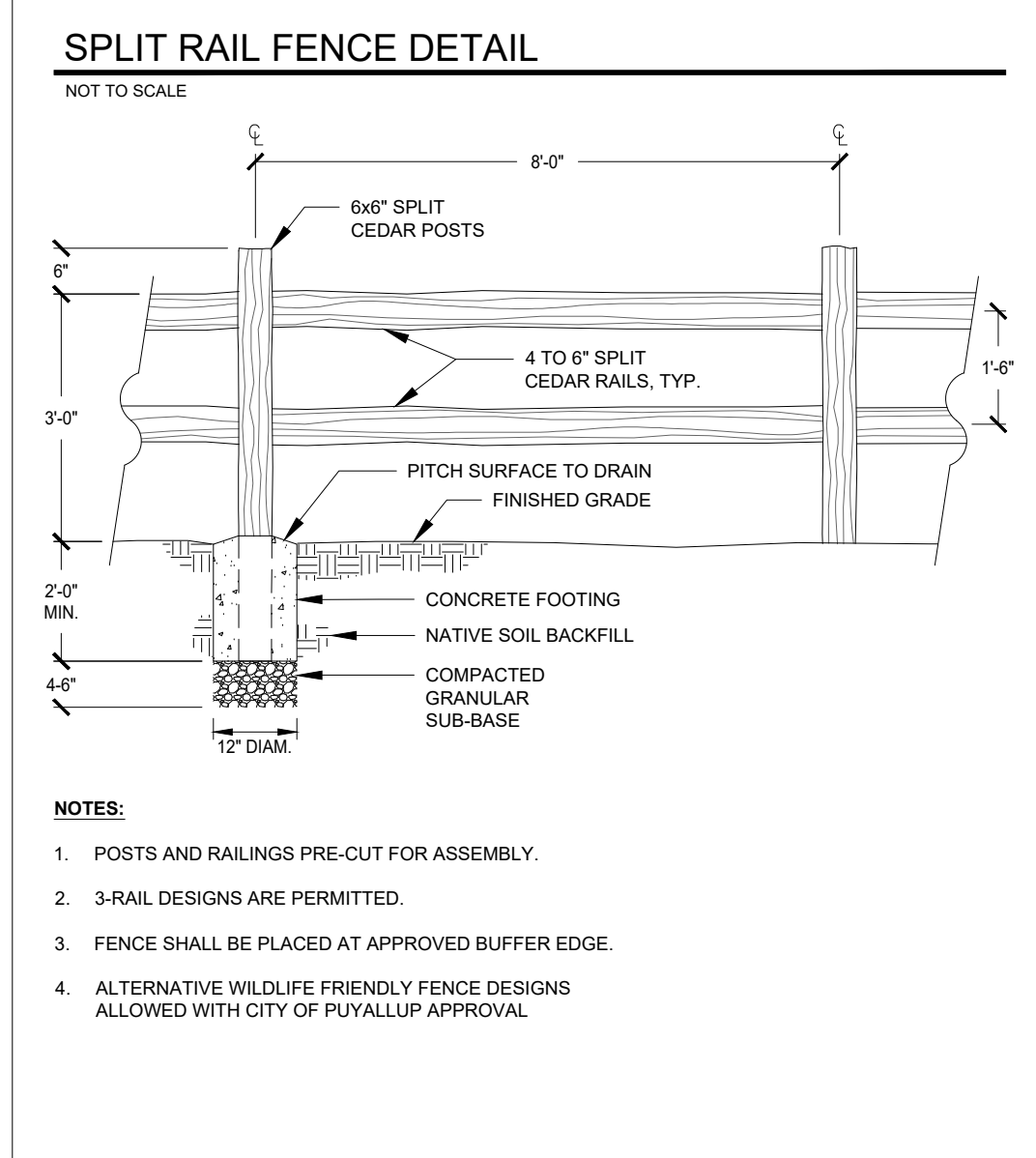

- NOTES:
- POSTS AND RAILINGS PRE-CUT FOR ASSEMBLY.
 - 3-RAIL DESIGNS ARE PERMITTED.
 - FENCE SHALL BE PLACED AT APPROVED BUFFER EDGE.
 - ALTERNATIVE HILDLIFE FRIENDLY FENCE DESIGNS ALLOWED WITH CITY OF PUYALLUP APPROVAL.

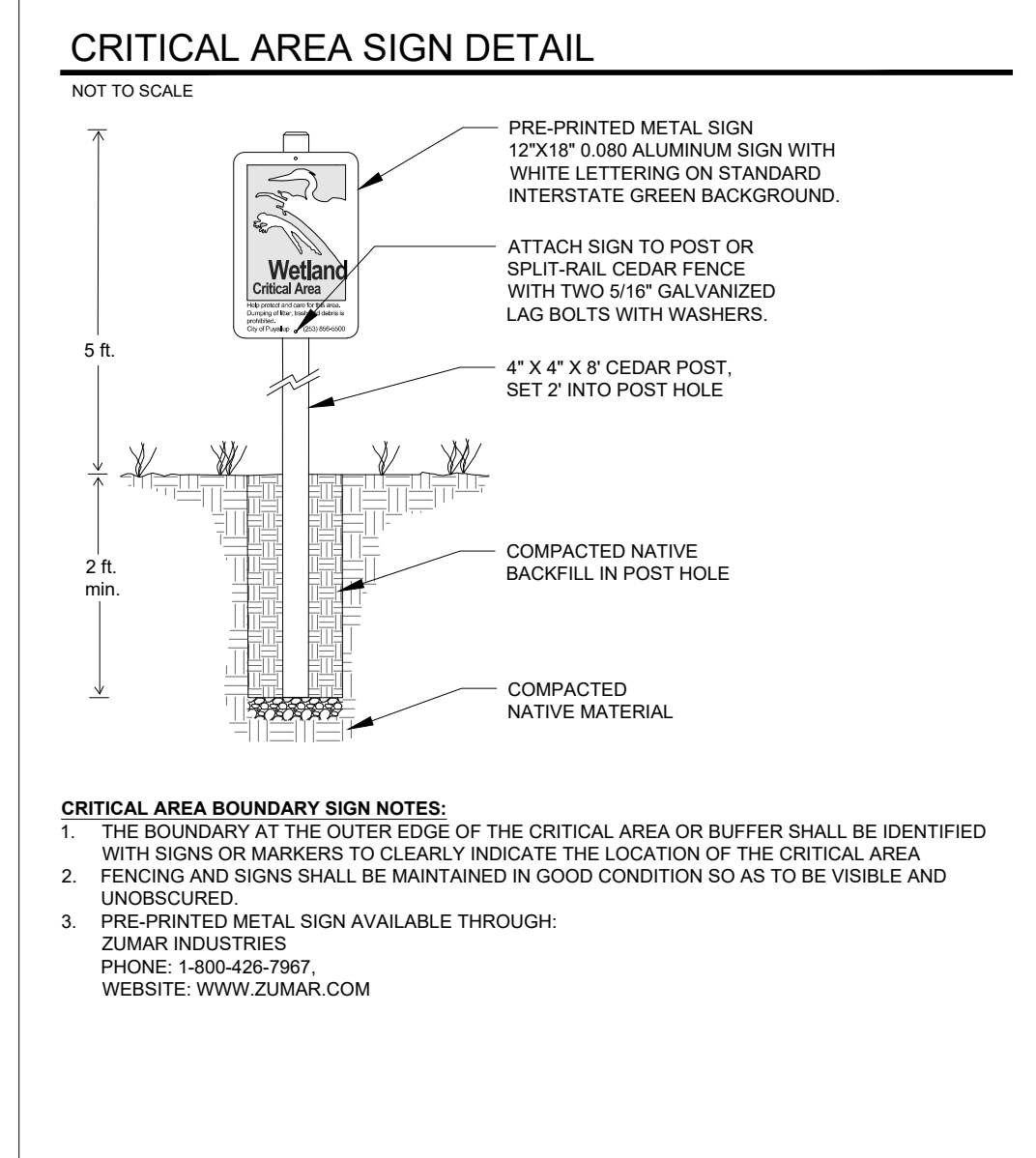

- CRITICAL AREA BOUNDARY SIGN NOTES:**
- THE BOUNDARY AT THE OUTER EDGE OF THE CRITICAL AREA OR BUFFER SHALL BE IDENTIFIED WITH SIGNS OR MARKERS TO CLEARLY INDICATE THE LOCATION OF THE CRITICAL AREA
 - FENCING AND SIGNS SHALL BE MAINTAINED IN GOOD CONDITION SO AS TO BE VISIBLE AND UNOBSCURED.
 - PRE-PRINTED METAL SIGN AVAILABLE THROUGH:
ZUMAR INDUSTRIES
PHONE: 1-800-426-7967
WEBSITE: WWW.ZUMAR.COM

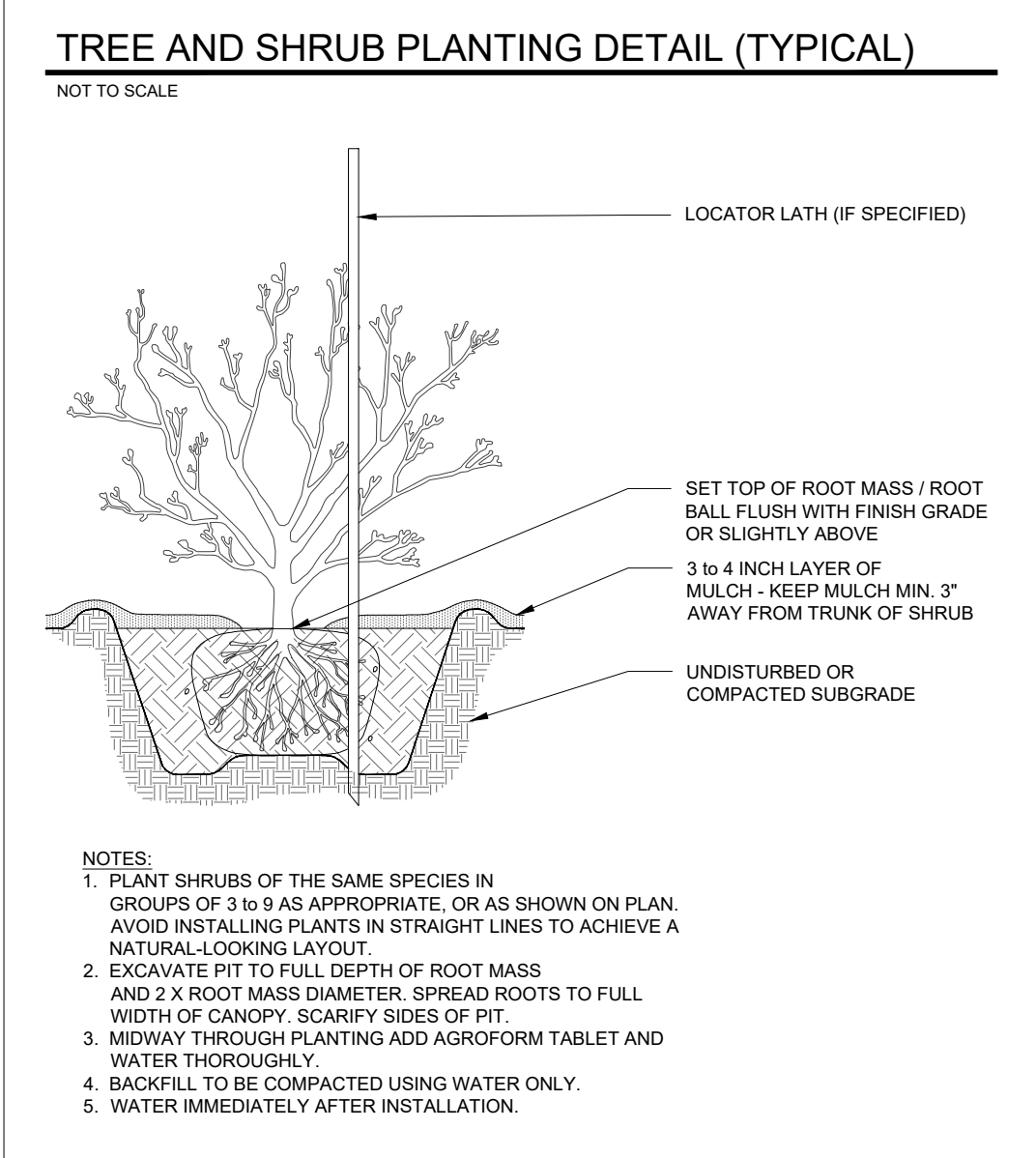

- NOTES:
- PLANT SHRUBS OF THE SAME SPECIES IN GROUPS OF 3 TO 9 AS APPROPRIATE, OR AS SHOWN ON PLAN. AVOID INSTALLING PLANTS IN STRAIGHT LINES TO ACHIEVE A NATURAL-LOOKING LAYOUT.
 - EXCAVATE PIT TO FULL DEPTH OF ROOT MASS AND 2 X ROOT MASS DIAMETER. SPREAD ROOTS TO FULL WIDTH OF CANOPY, SCARIFY SIDES OF PIT.
 - MIDWAY THROUGH PLANTING ADD AGROFORM TABLET AND WATER THOROUGHLY.
 - BACKFILL TO BE COMPACTED USING WATER ONLY.
 - WATER IMMEDIATELY AFTER INSTALLATION.

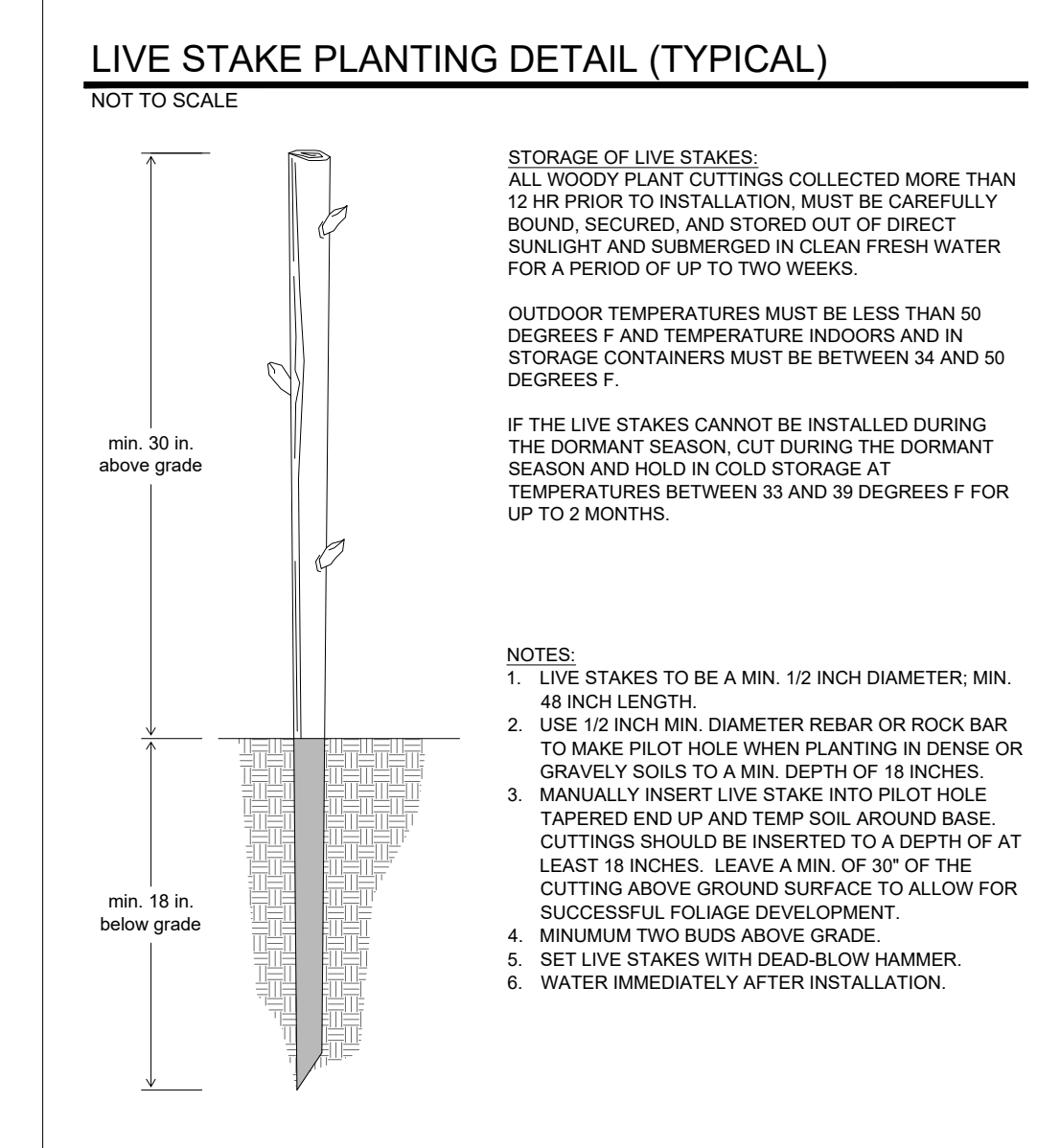

- STORAGE OF LIVE STAKES:**
ALL WOODY PLANT CUTTINGS COLLECTED MORE THAN 12 HR PRIOR TO INSTALLATION, MUST BE CAREFULLY BOUND, SECURED, AND STORED OUT OF DIRECT SUNLIGHT AND SUBMERGED IN CLEAN FRESH WATER FOR A PERIOD OF UP TO TWO WEEKS.
- OUTDOOR TEMPERATURES MUST BE LESS THAN 50 DEGREES F AND TEMPERATURE INDOORS AND IN STORAGE CONTAINERS MUST BE BETWEEN 34 AND 50 DEGREES F.
- IF THE LIVE STAKES CANNOT BE INSTALLED DURING THE DORMANT SEASON, CUT DURING THE DORMANT SEASON AND HOLD IN COLD STORAGE AT TEMPERATURES BETWEEN 35 AND 39 DEGREES F FOR UP TO 2 MONTHS.
- NOTES:
- LIVE STAKES TO BE A MIN. 1/2 INCH DIAMETER, MIN. 48 INCH LENGTH.
 - USE 1/2 INCH MIN. DIAMETER REBAR OR ROCK BAR TO MAKE PILOT HOLE WHEN PLANTING IN DENSE OR GRAVELLY SOILS TO A MIN. DEPTH OF 18 INCHES.
 - MANUALLY INSERT LIVE STAKE INTO PILOT HOLE TAPERED END UP AND TEMP SOIL AROUND BASE. CUTTINGS SHOULD BE INSERTED TO A DEPTH OF AT LEAST 18 INCHES. LEAVE A MIN. OF 50% OF THE CUTTING ABOVE GROUND SURFACE TO ALLOW FOR SUCCESSFUL FOLIAGE DEVELOPMENT.
 - MINIMUM TWO BUDS ABOVE GRADE.
 - SET LIVE STAKES WITH DEAD-BLOW HAMMER.
 - WATER IMMEDIATELY AFTER INSTALLATION.

EAST TOWN CROSSING
2902 E. PIONEER AVE.
PUYALLUP, WA 98374
PIERCE COUNTY PARCEL NUMBERS:
0420264021, 0420264053, 0420264054, 0420351030,
0420351029, 0420351026, & 0420351066

DATE: 3/14/2024
JOB: 2544.0001
BY: MW
SCALE: AS SHOWN
SHEET: 3.0

Appendix B – Photographs

Typical degraded conditions of Stream Z within ROW of East Pioneer Avenue



Typical conditions of Stream Y



Existing Stream Z crossing providing access from East Pioneer Avenue to site (source: Google Earth)



Appendix C – Qualifications

All determinations and supporting documentation, including this *Conceptual Mitigation Plan* prepared for the *East Town Crossing* project were prepared by, or under the direction of, Alex Murphy and Matt DeCaro of SVC. Technical assistance was provided by Ben Wright. In addition, report preparation was completed by Kyla Caddey, and final quality assurance/ quality control was completed by Laura Livingston.

Alex Murphy, AICP

Senior Environmental Planner & Project Manager

Professional Experience: 7 years

Alex Murphy is a Planner and Project Manager with a background in land use planning, site planning & design, permitting, and project management. He has over 7 years of experience working for local jurisdictions in the Intermountain West and Pacific Northwest with an emphasis on maximizing opportunities for culturally and environmentally sensitive projects.

Alex earned a Bachelor of Landscape Architecture degree from Utah State University. He is a Certified Planner through the American Institute of Certified Planners and has received formal training in climate adaptation planning for coastal communities from NOAA. Mr. Murphy currently assists in wetland, stream, and shoreline delineations and fish and wildlife habitat assessments; conducts environmental code analysis; and prepares environmental assessment and mitigation reports. He also manages development projects, supporting clients through the regulatory and planning process for various land use proposals.

Matt DeCaro

Principal

Professional Experience: 14 years

Matt DeCaro is a Principal and Senior Scientist with a diverse background in environmental planning, wetland science, stream ecology, water quality, tree assessments, site remediation, NEPA compliance, and project management. He manages a wide range of industrial, commercial, and multi-family residential projects throughout Western Washington, providing environmental permitting and regulatory compliance assistance for land use projects from their planning stages through entitlement and construction. His local expertise, diverse professional background, and positive relationships with regulatory personnel are integral components of his successful project outcomes.

Matt earned a Bachelor of Science degree with a focus in Environmental Science from the Evergreen State College in Olympia, Washington, with additional graduate-level coursework and research in aquatic restoration and salmonid ecology. Matt has received 40-hour wetland delineation training (*Western Mountains, Valleys, & Coast and Arid West Regional Supplements*) and regularly performs wetland, stream, and shoreline delineations. Matt has been formally trained in the use of the *2014 Washington State Wetland Rating System* and *Determination of Ordinary High Water Mark* by WSDOE, and he is a Pierce County Qualified Wetland Specialist and Wildlife Biologist. He has attended USFWS survey workshops for multiple threatened and endangered species, and he is a Senior Author of WSDOT Biological Assessments. Matt holds 40-hour HAZWOPER training and has managed Phase I Environmental Site Assessments, subsurface investigations, and contaminant remediation projects

throughout the Pacific Northwest. His diverse experience also includes NEPA compliance for federal permitting projects; noxious weed abatement; army ant research in the Costa Rican tropical rainforest; spotted owl surveys on federal and private lands; and salmonid spawning and migration surveys.

Ben Wright

Associate Principal and Senior Fisheries Biologist

Professional Experience: 20 years

Ben Wright is an Associate Principal and Senior Fisheries Biologist with a varied background in lake ecology, stream ecology, fisheries biology, water quality and climate science. Ben has 13 years of experience at the federal level providing technical assistance for both the development of infrastructure projects and management of aquatic resources. This technical assistance included providing oversight and design guidance on several restoration projects involving large woody debris installations, native riparian plantings, and stream channel relocations. He has experience developing biological assessments, water quality monitoring plans, and fisheries management plans. Ben has an additional 10 years of experience working on long-term ecological monitoring programs related to lakes, streams, water quality and climate. Ben currently works on permitting, design, construction guidance, and monitoring of several stream and wetland mitigation projects across western Washington.

Ben earned a Bachelor of Science degree in Genetics and Cell Biology with an emphasis in aquatic ecology from Washington State University and has a graduate certificate in Fisheries Management from Oregon State University. Ben's expertise includes endangered species monitoring, assessments and permitting, and NEPA documentation across disciplines gained during his work on federal highway projects. Ben also has experience in fish population assessments, utilizing genetic analysis, spawning escapement and movement studies. Ben has received formal training from the Washington State Department of Ecology in the Using the Revised 2014 Wetland Rating System for Western Washington, How to Determine the Ordinary High Water Mark, Navigating SEPA, How to Conduct a Forage Fish Survey and Puget Sound Coastal Processes, Shoreline Modifications and Beach Restoration. Ben has completed 40-hour wetland delineation training for the Western Mountains, Valleys, & Coast and Arid West Regional Supplement. Most recently, Ben has completed a short course in River Sediment Dynamics from River Restoration Northwest.

Kyla Caddey, PWS, Certified Ecologist

Senior Environmental Scientist

Professional Experience: 8 years

Kyla Caddey is a Senior Environmental Scientist with a diverse background in stream and wetland ecology, wildlife ecology and conservation, wildlife and natural resource assessments and monitoring, and riparian habitat restoration at various public and private entities. Kyla has field experience performing in-depth studies in both the Pacific Northwest and Central American ecosystems which included various environmental science research and statistical analysis. Kyla has advanced expertise in federal- and state-listed endangered, threatened, and sensitive species surveys and assessment of aquatic and terrestrial systems throughout the Puget Sound region. She has completed hundreds of wetland delineations and has extensive knowledge and interest in hydric soil identification. As the senior writer, she provides informed project oversight and performs final quality assurance / quality control on various types of scientific reports for agency submittal, including: Biological

Assessments/Evaluations; Wetland, Shoreline, and Fish and Wildlife Habitat Assessments; Mitigation Plans, and Mitigation Monitoring Reports. She currently performs wetland, stream, and shoreline delineations and fish and wildlife habitat assessments; prepares scientific reports; and provides environmental permitting and regulatory compliance assistance to support a wide range of commercial, industrial, and multi-family residential land use projects.

Kyla earned a Bachelor of Science degree in Environmental Science and Resource Management from the University of Washington, Seattle with a focus in Wildlife Conservation and a minor in Quantitative Science. She has also completed additional coursework in Comprehensive Bird Biology from Cornell University. Ms. Caddey is a Certified Professional Wetland Scientist (PWS #3479) through the Society of Wetland Scientists and Certified Ecologist through the Ecological Society of America. She has received 40-hour wetland delineation training (Western Mtns, Valleys, & Coast and Arid West Regional Supplement), is a Pierce County Qualified Wetland Specialist and Wildlife Biologist, and is a USFWS-approved Mazama pocket gopher survey biologist. Kyla has been formally trained through the Washington State Department of Ecology, Coastal Training Program, and the Washington Native Plant Society in winter twig and grass, sedge, and rush identification for Western WA; Using the Credit-Debit Method in Estimating Wetland Mitigation Needs; How to Determine the Ordinary High Water Mark; Using Field Indicators for Hydric Soils; How to Administer Development Permits in Washington Shorelines; Puget Sound Coastal Processes; and Forage Fish Survey Techniques. Additionally, she has received formal training in preparing WSDOT Biological Assessments.

Laura Livingston

Senior Environmental Planner

Professional Experience: 9 years

Laura Livingston is an Environmental Planner with a background in water quality monitoring, invasive species monitoring, wildlife monitoring, wilderness stewardship, and erosion control projects. Laura has field experience working on natural resources projects, with an emphasis on stream and river projects, in the Northwest, Northeast, and Southwest United States. She has also worked on a variety of environmental science research, grant, and teaching projects requiring scientific writing, science communication, laboratory work, and statistical analysis. She currently performs ordinary high water delineations; conducts environmental code analysis; and prepares environmental assessment and mitigation reports, biological evaluations, and permit applications to support clients through the regulatory and planning process. Laura has a particular interest in shoreline projects and has prepared a variety of application materials to support projects within Shoreline Master Program jurisdictions.

Laura earned a Master of Science degree in Environmental Science from Washington State University, Pullman. She has received training from the Washington State Department of Ecology in How to Administer Shoreline Development Permits in Western Washington's Shorelines, Determining the Ordinary High Water Mark, the revised Washington State Wetland Rating System, Puget Sound Coastal Processes, How to Conduct a Forage Fish Survey, and Using the Credit-Debit Method for Estimating Mitigation Needs. Laura has also received training from the Washington State Department of Transportation in Biological Assessment Preparation for Transportation Projects and is listed by WSDOT as a junior author for preparing Biological Assessments. Laura is interested in stormwater management and has received a certificate in Low Impact Development Design from the Washington Stormwater Center.