



Construction Stormwater Pollution Prevention Plan

PREPARED FOR:

Greg Helle
1001 Shaw Road
Puyallup, WA 98372

PROJECT:

East Town Crossing
2902 E Pioneer
Puyallup, WA 98372
2230723.10

PREPARED BY:

Christopher Watt
Project Engineer

REVIEWED BY:

Todd C. Sawin, PE, DBIA, LEED AP
Principal

DATE:

November 2023
Revised February 2024

Construction Stormwater Pollution Prevention Plan

PREPARED FOR:

Greg Helle
1001 Shaw Road
Puyallup, WA 98372

PROJECT:

East Town Crossing
2902 E Pioneer
Puyallup, WA 98372
2230723.10

PREPARED BY:

Christopher Watt
Project Engineer

REVIEWED BY:

Todd C. Sawin, PE, DBIA, LEED AP
Principal

DATE:

November 2023
Revised February 2024



02/21/2024

I hereby state that this [Construction Stormwater Pollution Prevention Plan](#) for the [East Town Crossing](#) project has been prepared by me or under my supervision and meets the standard of care and expertise that is usual and customary in this community for professional engineers. I understand that [the City of Puyallup](#) does not and will not assume liability for the sufficiency, suitability, or performance of drainage facilities prepared by me.

Table of Contents

Section	Page
1.0 Introduction	1
2.0 Project Description	2
3.0 Existing Site Conditions.....	2
4.0 Adjacent Areas and Drainage	2
5.0 Critical Areas	3
6.0 Soils.....	3
7.0 Potential Erosion Problems	3
8.0 Construction Stormwater Pollution Prevention Elements.....	3
8.1 Mark Clearing Limits	3
8.2 Establish Construction Access.....	4
8.3 Control Flow Rates.....	4
8.4 Install Sediment Controls	4
8.5 Stabilize Soils and Dust Control.....	4
8.6 Protect Slopes.....	5
8.7 Protect Drain Inlets.....	5
8.8 Stabilize Channels and Outlets.....	5
8.9 Control Pollutants.....	5
8.9.1 Required BMPs	6
8.10 Control Dewatering	7
8.11 Maintain BMPs.....	7
8.12 Manage the Project.....	7
9.0 Construction Sequence and Phasing	8
9.1 Construction Sequence.....	8
9.2 Construction Phasing.....	8
10.0 Construction Schedule.....	9
11.0 Financial/Ownership Responsibilities	9
12.0 Certified Erosion and Sediment Control Lead (CESCL)	9
13.0 Monitoring and Sampling Requirements.....	10

13.1	Site Inspection.....	10
13.2	Stormwater Quality Sampling	11
13.2.1	Turbidity Sampling	11
13.2.2	pH Sampling.....	11
14.0	Conclusion.....	12

Exhibits

Appendix F

- F-1 TESC Plan
- F-2 TESC Notes and Details

Appendix G

Inspection Logs

Appendix H

Best Management Practices (BMPs)

- BMP C102 Buffer Zones
- BMP C103 High Visibility Fence BMP C105 Stabilized Construction Entrance
- BMP C107 Construction Road / Parking Area Stabilization
- BMP C120 Temporary and Permanent Seeding
- BMP C121 Mulching
- BMP C122 Nets and Blankets
- BMP C123 Plastic Covering
- BMP C140 Dust Control
- BMP C150 Materials on Hand
- BMP C151 Concrete Handling
- BMP C152 Sawcutting and Surface Pollution Prevention
- BMP C153 Material Delivery, Storage, and Containment
- BMP C160 Certified Erosion and Sediment Control Lead
- BMP C209 Outlet Protection
- BMP C220 Storm Drain Inlet Protection
- BMP C233 Silt Fence
- BMP C241 Sediment Pond (Temporary)

1.0 Introduction

In 1972, Congress passed the Federal Water Pollution Control Act (FWPCA), also known as the Clean Water Act (CWA), to restore and maintain the quality of the nation's waterways. The ultimate goal was to make sure that rivers and streams were fishable, swimmable, and drinkable. In 1987, the Water Quality Act (WQA) added provisions to the CWA that allowed the Environmental Protection Agency to govern stormwater discharges from construction sites. The National Pollutant Discharge Elimination System (NPDES) General Permit includes provisions for development of a Stormwater Pollution Prevention Plan (SWPPP) to maximize the potential benefits of pollution prevention and sediment and erosion control measures at construction sites.

The proposed project will disturb more than 1 acre of area, and therefore is required to obtain an NPDES General Permit for Stormwater Associated with Construction Activities.

The 2019 Department of Ecology (DOE) *Stormwater Management Manual for Western Washington (SMMWW)* requires a Construction SWPPP for projects that add or replace more than 2,000 square feet of impervious surfaces. The proposed project will exceed this threshold; therefore, a Construction SWPPP is required.

Development, implementation, and maintenance of the Construction SWPPP will provide the selected General Contractor with the framework for reducing soil erosion and minimizing pollutants in stormwater during construction of the proposed project. The Construction SWPPP will:

- Define the characteristics of the site and the type of construction that will occur.
- Describe the practices that will be implemented to control erosion and the release of pollutants in stormwater.
- Create an implementation schedule to ensure that the practices described in this Construction SWPPP are in fact implemented, and to evaluate the plan's effectiveness in reducing erosion, sediment, and pollutant levels in stormwater discharged from the site.
- Describe the final stabilization/termination design to minimize erosion and prevent stormwater impacts after construction is complete.

This Construction SWPPP:

- Identifies the SWPPP Coordinator with a description of this person's duties.
- Identifies the Stormwater Pollution Prevention Team (SWPP Team) that will assist in implementation of the Construction SWPPP during construction.
- Describes the existing site conditions, including existing land use for the site, the soil types at the site, as well as the location of surface waters that are located on or next to the site.
- Identifies the body or bodies of water that will receive runoff from the construction site, including the ultimate body of water that receives the stormwater.
- Identifies the drainage areas and potential stormwater contaminants.
- Describes the stormwater management controls and various Best Management Practices (BMPs) necessary to reduce erosion, sediment, and pollutants in stormwater discharge.
- Describes the facility monitoring plan and how controls will be coordinated with construction activities.
- Describes the implementation schedule and provisions for amendment of the plan.

2.0 Project Description

The East Town Crossing project proposes to develop an approximately 10.93-acre site located on Tax Parcels 0420264021, 0420264053, 0420264054, 0420351066, 0420351030, 0420351029, 0420351026 in the City of Puyallup, Washington. Refer to Appendix A, Exhibit A-1 for the Vicinity Map.

The developed site includes 8 multifamily buildings, 1 property management/clubhouse building, 2 commercial buildings, associated parking, road access, and utilities. Perimeter and island landscaping will be provided as required by the City of Puyallup. The paved areas will drain to the proposed catch basins located the sites proposed local low points. Runoff collected in these catch basins will be treated by one of five BioPods before being conveyed to one of three R-Tanks where stormwater will be detained. Control structures will control the release rate of stormwater discharging to the enhanced channel that lines the east and north of the site. Stormwater ultimately discharges to the Puyallup River via open channels alongside E Pioneer, running west.

The proposal will follow the stormwater management design criteria outlined in the DOE 2019 *SMMWW*. Control methods during construction include working during the dry season, minimizing the amount of area that is disturbed at any given time, installing a stabilized construction entrance, placing inlet protection at catch basins and culvert entrances, utilizing straw wattles and Baker Tank and filtration assembly designed by Clearwater Services, and utilizing silt fence, if necessary.

Refer to Appendix F, Exhibits F-1 and F-2 for the TESC Plan and TESC Notes and Details respectively.

3.0 Existing Site Conditions

The existing area is approximately 10.93 acres and is currently developed and undeveloped land cover. Within the seven parcels, a network of dirt and gravel access roads connect E Pioneer, Shaw Rd E, and the commercial property to the south. In the southwest parcels, there is an existing residential structure and a vacant residential lot. The majority of the landcover is made up of tall grass, shrubs, and a few trees.

The site contains a detention pond that receives runoff from the commercial property to the south before overflowing into the existing channel lining the east and north of the property. Apart from the detention pond, the site generally slopes from southeast to northwest. The large majority of runoff discharges to the northern portion of the channel. A topographical survey of the project was prepared by Abbey Road Group. that shows existing site conditions. See Appendix A, Exhibit A-2 for the Existing Conditions Map.

4.0 Adjacent Areas and Drainage

In existing conditions, the commercial property to the south drains to the detention pond located on the southeastern parcel of the site and discharges to the channel lining the eastern portion of the site. The detention pond will be maintained in Phase 1 of construction, however, will be replaced by an underground detention system in Phase 2.

Shaw Road E to the west contains its own stormwater collection and conveyance system which prevents discharge to the site. However, Pioneer E to the north drains into channels on either side of the road, including the channel on the north end of the project site. Frontage improvements are proposed in this project during phase 2 that will redirect runoff to the downstream connection via an enhanced stream.

Stormwater leaves the site to the north via the channel that runs around the east and north of the site. A culvert collects the water from the channel and directs it northwest under the intersection of E Pioneer and Shaw Road E. A channel then runs along E Pioneer on the roadside of the railroad before it intersects another culvert directing water to the Puyallup River.

5.0 Critical Areas

There are no known critical areas on or near the project site.

6.0 Soils

The National Resources Conservation Service (NRCS) classifies the onsite soils as Briscot Loam in the northern two-thirds of the site and Puyallup fine sandy loam in the lower third of the site. Appendix A, Exhibit A-4 provides the NRCS soil map. Briscot Loam is classified as hydrologic soil group B/D with poorly draining characteristics. Puyallup fine sandy loam is classified as hydrologic soil group A with well-draining characteristics.

In addition to the NRCS information, Krazan & Associates, Inc prepared a geotechnical report for the site. On March 4, 2021, two large-scale pilot infiltration tests were completed. Based on the results presented in the Geotechnical Report, it was determined that the soils at the site contain high silt content and are considered a very low to relatively impermeable layer. Due to this, in opposition of the NRCS report, the entire site is not recommended for any infiltration due to the presence of unfavorable soils.

In relation to construction efforts, original testing by Krazan & Associates, Inc. shows that the underlying soils are unsuitable for supporting traffic loads when wet. It is recommended that a Geotechnical Engineer is present to provide guidance during construction.

See Appendix B, Exhibit B-1 for the Krazan & Associates, Inc. Geotechnical Engineering Report and Appendix B-2 for the Migizi Group Geotechnical Letter.

7.0 Potential Erosion Problems

Based on an investigation by Krazan & Associates, Inc., there are steep slopes located roughly 300 feet to the south and east of the site mapped as moderate to high for shallow landslide susceptibility and moderate for deep susceptibility. However, there are no historic landslides or debris mapped at the nearby slopes. Due to the presence of a developed and partially developed parcel separating the landslide hazard and the site, Krazan & Associates, Inc. believes there is minimum to no risk to the planned development from nearby slopes.

In relation to onsite soil, underlying soil is unsuitable for supporting traffic loads when wet. Appropriate measures should be taken to stabilize soils for construction work before the wet season.

8.0 Construction Stormwater Pollution Prevention Elements

The purpose of this section is to describe how each of the 12 Construction Stormwater Pollution Prevention elements has been addressed and to identify the type and location of BMPs used to satisfy the required element. If an element is not applicable to the project, a reason is provided.

8.1 Mark Clearing Limits

Prior to beginning land-disturbing activities, clearing limits will be marked with high visibility plastic or metal fencing (BMP C103) as shown on the TESC Plan in Appendix F, Exhibit F-1. All

vegetated areas outside the marked clearing limits shall be preserved in existing conditions, as well as buffer zones (BMP C102) set up around the existing stream. Fencing will also be used to protect the existing storm facility.

8.2 Establish Construction Access

A stabilized construction entrance (BMP C105) is proposed at the northeast corner of the site off E Pioneer. If sediment is transported onto the road surface, the road shall be cleaned by shoveling or sweeping prior to washing. Sediment removal by washing alone will not be allowed. If sediment is tracked from the site, the City of Puyallup may require stabilization of internal roads to contain the sediment or require the installation of wheel wash basins. Construction roads / parking areas (BMP C107) will be stabilized wherever they are used.

8.3 Control Flow Rates

Straw wattles shall be provided to prevent erosion and control flow rates leaving the site. The velocity of water leaving the site shall not exceed 3 ft/s if the discharge is to the existing channel. Clearwater Services has designed a Baker Tank and filtration assembly to control the stormwater release rate and quality before its discharge to the channel. Permanent flow control systems must be constructed and functioning prior to constructing hard surfaces.

8.4 Install Sediment Controls

As part of initial construction activities, BMPs will be installed to trap sediment onsite. Inlet Protection (BMP C220) for existing catch basins and proposed catch basins within the project area and in the adjacent streets that may receive runoff shall be implemented. Silt fence (BMP C233) will be placed along all downgradient boundaries of the proposed project limits to prevent sediment laden runoff from leaving the site. A temporary sediment pond (BMP C241) will also be used, of which sizing calculations are included in the CFG Permit PRGR20230972.

Baker Tank sizing calculations are included in the CFG Permit PRGR20230972.

8.5 Stabilize Soils and Dust Control

Exposed areas and soil stockpiles must be stabilized according to the following schedule:

1. From April 1 to October 31, all disturbed areas at final grade and all exposed areas that are scheduled to remain unworked for more than 30 days shall be stabilized within 10 days.
2. From November 1 to March 31, all exposed soils at final grade shall be stabilized immediately using permanent or temporary measures. Exposed soils with an area greater than 5,000 square feet that are scheduled to remain unworked for more than 24 hours, and exposed areas of less than 5,000 square feet that will remain unworked for more than 7 days shall be stabilized immediately.

All disturbed areas that are not planned to be constructed on within 90 days from time of clearing and grading shall be revegetated with the native vegetation.

To stabilize soils, BMPs such as temporary and permanent seeding (BMP C120), mulching (BMP C121), nets and blankets (BMP C122), and plastic coverings (BMP C123) will be utilized. While Dust will be controlled following BMP C140.

8.6 Protect Slopes

The majority of the site has flat slopes of 0-3%. There are small, isolated areas with slopes greater than 3%, however, no slopes over 20% are being disturbed. All exposed soil not covered by buildings, roadway, or sidewalks will be Hydroseeded, and their slopes will be no greater than 2:1.

8.7 Protect Drain Inlets

Storm drain inlets shall be protected so that surface water runoff does not enter the conveyance system without first being filtered. Inlets shall be inspected weekly, at a minimum, and daily during storm events. Storm Drain Inlet Protection (BMP C220) will be provided.

8.8 Stabilize Channels and Outlets

There is an existing channel alongside E Pioneer that will be protected as necessary. Provide stabilization, including armoring material (if approved by the AHJ) adequate to prevent erosion of outlets, adjacent stream banks, slopes, and downstream reaches at the outlets of all conveyance systems. Outlet protection (BMP C209) will be used to prevent scour at conveyance outlets and minimize downstream erosion.

8.9 Control Pollutants

All waste materials will be collected and stored in a securely closed metal dumpster. All trash and construction debris from the site will be deposited in the dumpster. The dumpster will be emptied a minimum of once per week, and the trash will be hauled to the local landfill. No construction materials will be buried onsite. All personnel will be instructed regarding the correct procedure for waste disposal. All sanitary waste will be collected from the portable units a minimum of three times per week. Good housekeeping and spill control practices will be followed during construction to minimize stormwater contamination from petroleum products, fertilizers, and concrete.

Table 1 below lists several pollutants that are commonly found on construction sites that have the potential to contaminate storm runoff. These pollutants will be present, mainly in areas of building and pavement construction. The Contractor and the SWPPP/TESC Coordinator will be responsible for identifying areas where these pollutants are being used and monitor runoff coming from these areas. Pollutant sources will be covered with plastic if contaminated runoff is observed from these areas. If contaminated runoff is found in the sediment trap or soils, the Erosion Control Specialist will direct the Contractor to remove the polluted water/soil and dispose of it in an approved area offsite.

Table 1 – Potential Construction Site Stormwater Pollutants

Trade Name Material	Chemical/Physical Description ⁽¹⁾	Stormwater Pollutants ⁽¹⁾
Pesticides (insecticides, fungicides, herbicide, rodenticides)	Various colored to colorless liquid, powder, pellets, or grains	Chlorinated hydrocarbons, organophosphates, carbamates, arsenic
Fertilizer	Liquid or solid grains	Nitrogen, phosphorous
Plaster	White granules or powder	Calcium sulphate, calcium carbonate, sulfuric acid
Cleaning solvents	Colorless, blue, or yellow-green liquid	Perchloroethylene, methylene chloride, trichloroethylene, petroleum distillates
Asphalt	Black solid	Oil, petroleum distillates
Concrete	White solid	Limestone, sand

Trade Name Material	Chemical/Physical Description ⁽¹⁾	Stormwater Pollutants ⁽¹⁾
Glue, adhesives	White or yellow liquid	Polymers, epoxies
Paints	Various colored liquid	Metal oxides, Stoddard solvent, talc, calcium carbonate, arsenic
Curing compounds	Creamy white liquid	Naphtha
Wastewater from construction equipment washing	Water	Soil, oil & grease, solids
Wood preservatives	Clear amber or dark brown liquid	Stoddard solvent, petroleum distillates, arsenic, copper, chromium
Hydraulic oil/fluids	Brown oily petroleum hydrocarbon	Mineral oil
Gasoline	Colorless, pale brown or pink petroleum hydrocarbon	Benzene, ethyl benzene, toluene, xylene, MTBE
Diesel fuel	Clear, blue-green to yellow liquid	Petroleum distillate, oil & grease, naphthalene, xylenes
Kerosene	Pale yellow liquid petroleum hydrocarbon	Coal oil, petroleum distillates
Antifreeze/coolant	Clear green/yellow liquid	Ethylene glycol, propylene glycol, heavy metals (copper, lead, zinc)
Erosion	Solid Particles	Soil, Sediment

⁽¹⁾ Data obtained from MSDS when available

8.9.1 Required BMPs

The following BMPs or equivalent measures are required of all businesses and agencies during concrete pouring and asphalt application at temporary sites:

- Employees must be educated on the pollution hazards of concrete and asphalt application and cutting.
- Loose aggregate chunks and dust must be swept or shoveled and collected (not hosed down a storm drain) for recycling or proper disposal at the end of each workday, especially at work sites such as streets, driveways, parking lots, sidewalks, curbs, and gutters where rain can readily pick up the loose material and carry it to the nearest stormwater conveyance. Small amounts of excess concrete, grout, and mortar can be disposed of in the trash.
- Storm drain covers or similarly effective containment devices must be placed over all nearby drains at the beginning of each day. Shovel or vacuum slurry and remove from the site. All accumulated runoff and solids must be collected and properly disposed at the end of each workday, or more often if necessary.
- Exposed aggregate washing, where the top layer of unhardened concrete is hosed or scraped off to leave a rough finish, must be done with a mechanism for containment and collection of the discarded concrete slurry (such as the storm drain covers mentioned above). The easiest way to contain the washwater will be to direct the washings to a hole in the ground where the water can percolate into the ground and the solids later covered with soil.
- If directed to a drain, a catch basin filter insert must be used to remove the solids. This is especially useful if the activity must proceed on rainy days.
- Cleaning of concrete application and mixing equipment or concrete vehicles on the work site must be done in a designated area where the rinse water is controlled. The rinse water must either be collected for proper disposal or put into a hole in the ground where the water

can percolate away, and the solids later covered with soil or recovered and disposed or recycled.

The use of any treatment BMP must not result in the violation of groundwater, surface water, or drinking water quality standards.

8.10 Control Dewatering

Most proposed improvements are above the observed groundwater, with the exception of some utility installment. Should groundwater be encountered during construction, dewatering control measures shall be used to prevent untreated discharge of sediment-laden water. Clean dewatering shall not be routed through stormwater sediment ponds. Measures may include vehicle transport offsite for legal disposal in a manner that does not pollute surface waters, or use of a sedimentation bag with outfall to a ditch or swale for small volumes of localized dewatering (if approved by the AHJ).

8.11 Maintain BMPs

Temporary and permanent erosion and sediment control BMPs shall be maintained and repaired as needed to assure performance of their intended functions.

Sediment control BMPs such as silt fencing and drain inlet protection shall be inspected weekly or after a runoff-producing event. Temporary erosion and sediment control BMPs will be removed within 30 days after final site stabilization is achieved. The following inspection and maintenance practices will be used to maintain erosion and sediment controls:

- Built-up sediment will be removed from silt fencing when it has reached one-third the height of the fence.
- Silt fences will be inspected for depth of sediment, tears in the fabric, attachment to the fence posts, and to determine that fence posts are firmly in the ground. Accumulated sediment will be removed from behind the fence.
- Temporary and permanent seeding will be inspected for bare spots, washouts, and healthy growth.
- The Contractor Certified Erosion and Sedimentation Control Lead (CESCL) will provide erosion control inspection services and stormwater disposal monitoring through construction. The City Inspector will be notified of daily construction activities and scheduled meetings between the Erosion Control Inspector and the Contractor.

The maintenance inspection report will be made after each inspection. Copies of the report forms to be completed by the SWPPP Coordinator are attached as Appendix G of this Construction SWPPP. Completed forms will be provided to the City Inspector and will also be maintained onsite during the entire construction project. If construction activities or design modifications are made to the site plan that could impact stormwater, or if AHBL determines that the measures are not adequate to prevent erosion and the discharge of sediment from the site (based on turbidity measurements), this Construction SWPPP will be amended appropriately. The amended Construction SWPPP will have a description of the new activities that contribute to the increased pollutant loading and the planned source control activities.

8.12 Manage the Project

The following practices will be required during construction to properly manage activities:

- Comply with seasonal work limitations.
- Inspect, maintain, and repair BMPs.
- Identify a Certified Erosion and Sediment Control Lead (CESCL).
- Maintain the Construction SWPPP onsite at all times, including narrative and plans.

9.0 Construction Sequence and Phasing

9.1 Construction Sequence

The construction sequence is described below:

1. Arrange and attend a pre-construction meeting with the City of Puyallup.
2. Stake/flag clearing and construction limits.
3. Construct all temporary erosion control BMPs according to the TESC plan. Install inlet sediment protection in existing catch basins.
4. Install construction entrance.
5. Demolish existing site features indicated for removal.
6. Maintain erosion control measures in accordance with City of Puyallup standards and manufacturer recommendations.
7. Rough grade and fill site. All grading shall be done in conformance with the grading plan.
8. Construct storm system and install inlet sediment protection to new basins.
9. Install all remaining site utilities and associated infrastructure.
10. Apply erosion control mulch and seeding, straw mulch or equal, to areas that will not be brought to final grade or permanently vegetated within 7 days of exposure during the dry season, and 2 days of exposure during the wet season (October 1 – April 30).
11. Relocate erosion control measures or install new measures so that, as the site conditions change, the erosion and sediment control is always in accordance with the City of Puyallup Construction SWPPP minimum requirements.
12. Final grade site and install final surface treatments. Ensure that surface water is positively directed toward proposed storm collection facilities.
13. Remove remaining temporary erosion control items once site has been stabilized and upon approval of the City of Puyallup.

9.2 Construction Phasing

Work under this permit will be completed in two phases. Refer to the associated Plans.

10.0 Construction Schedule

Construction is scheduled to begin in TBD and is expected to be completed in TBD. The majority of earth moving activities will be scheduled during the dry season. During construction, measures will be taken to prevent the transportation of sediment from the site to receiving waters. These measures include the use of:

- Buffer Zones (BMP C102)
- Stabilized Construction Entrance (BMP C105)
- Construction Road / Parking Area Stabilization (BMP C107)
- Temporary and Permanent Seeding (BMP C120)
- Mulching (BMP C121)
- Nets and Blankets (BMP C122)
- Plastic Covering (BMP C123)
- Dust Control (BMP C140)
- Materials on Hand (BMP C150)
- Concrete Handling (BMP C151)
- Sawcutting and Surfacing Pollution Prevention (BMP C152)
- Material Delivery, Storage, and Containment (BMP C153)
- Outlet Protection (BMP C209)
- Storm Drain Inlet Protection (BMP C220)
- Silt Fence (BMP C233)
- Sediment Pond (Temporary) (BMP C241)

11.0 Financial/Ownership Responsibilities

The contractor is responsible for obtaining performance and maintenance bonds in accordance with City of Puyallup requirements.

12.0 Certified Erosion and Sediment Control Lead (CESCL)

The General Contractor shall be required to provide a CESCL prior to construction. Once this individual is identified, the City Inspector will be notified.

The Contractor will designate their CESCL here:

Name: _____

Address: _____

Phone: _____

Fax Number: _____

The CESCL is required to meet DOE certification requirements. The City Inspector will be provided with CESCL information.

The duties of the CESCL include:

- Implement the Construction SWPPP/TESC plan with the aid of the SWPP Team.
- Oversee maintenance practices identified as BMPs in the Construction SWPPP.

- Conduct or provide for inspection and monitoring activities.
- Sample stormwater for turbidity using a turbidity meter.
- Identify other potential pollutant sources and make sure they are added to the plan.
- Identify any deficiencies in the Construction SWPPP and make sure they are corrected.
- Ensure that any changes in construction plans are addressed in the Construction SWPPP.

To aid in the implementation of the Construction SWPPP, the members of the SWPP Team include the following: General Contractor, CESCL, City of Puyallup Inspector, City of Puyallup, the geotechnical engineering consultant, and AHBL.

The General Contractor will ensure that all housekeeping and monitoring procedures are implemented, while the CESCL will ensure the integrity of the structural BMPs. The SWPP Team will observe construction and erosion control practices and recommend revisions or additions to the Construction SWPPP and drawings.

Pollution Prevention Team

Title	Name(s)	Phone Number
Certified Erosion and Sediment Control Lead (CESL)	TBD	
Resident Engineer	Todd Sawin (AHBL)	(253) 383-2422
Emergency Ecology Contact	TBD	
Emergency Permittee / Owner Contact	Greg Helle (Absher)	(253) 845-9544
Non-Emergency Owner Contact	TBD	
Monitoring Personnel	TBD	
Ecology Regional Office	Southwest Regional Office – Lacey	(360) 407-6300

13.0 Monitoring and Sampling Requirements

Monitoring includes visual inspection, sampling for water quality parameters of concern, and documentation of the inspection and sampling findings in a logbook. A site logbook will be maintained for all on-site construction activities and will include:

- A record of the implementation of the CSWPPP and other permit requirements
- Site inspections
- Stormwater sampling data

File a blank form from under Appendix G.

The site log book must be maintained on-site within reasonable access to the site and be made available upon request to Ecology or the City of Puyallup.

13.1 Site Inspection

Site inspections will be conducted at least once every calendar week and within 24 hours following any discharge from the site. For sites that are temporarily stabilized and inactive, the required frequency is reduced to once per calendar month.

13.2 Stormwater Quality Sampling

13.2.1 Turbidity Sampling

Requirements include calibrated turbidity meter to sample site discharges for compliance with DOE. Sampling will be conducted at all discharge points at least once per week.

The benchmark for turbidity value is 25 nephelometric turbidity units (NTU) and a transparency of at least 33 centimeters.

If the discharge's turbidity is 26 to 249 NTU **or** the transparency is less than 33 cm but equal to or greater than 6 cm, the following steps will be conducted:

1. Review the CSWPPP for compliance with Special Condition S9 (Stormwater Pollution Prevention Plan). Make appropriate revisions within 7 days of the date the discharge exceeded the benchmark.
2. Immediately begin the process to fully implement or maintain appropriate source control and/or treatment BMPs as soon as possible. Address the problems within 10 days of the date the discharge exceeded the benchmark. If installation of necessary treatment BMPs is not feasible within 10 days, Ecology may approve additional time when the Permittee requests an extension within the initial 10-day response period.
3. Document BMP implementation and maintenance in the site logbook

If turbidity exceeds 250 NTU **or** the transparency is 6 cm or less at any time, the following steps will be conducted:

1. Telephone or submit an electronic report to the applicable Ecology Region's Environmental Report Tracking System (ERTS) within 24 hours.
 - <https://www.ecology.wa.gov/About-us/Get-involved/Report-an-environmental-issue>
 - Southwest Region (Pierce): (360) 407-6300
2. Immediately begin the process to fully implement and maintain appropriate source control and/or treatment BMPs as soon as possible. Address the problems within 10 days of the date the discharge exceeded the benchmark. If installation of necessary treatment BMPs is not feasible within 10 days, Ecology may approve additional time when the Permittee requests an extension within the initial 10-day response period
3. Document BMP implementation and maintenance in the site log book.
4. Continue to sample discharges daily until one of the following is true:
 - Turbidity is 25 NTU (or lower).
 - Transparency is 33 cm (or greater).
 - Compliance with the water quality limit for turbidity is achieved.
 - 1 - 5 NTU over background turbidity, if background is less than 50 NTU
 - 1% - 10% over background turbidity, if background is 50 NTU or greater
 - The discharge stops or is eliminated.

13.2.2 pH Sampling

pH monitoring is required for "Significant concrete work" (i.e. greater than 1000 cubic yards poured concrete or recycled concrete over the life of the project). The use of engineered soils (soil

amendments including but not limited to Portland cement-treated base [CTB], cement kiln dust [CKD] or fly ash) also requires pH monitoring.

For significant concrete work, pH sampling will start the first day concrete is poured and continue until it is cured, typically three (3) weeks after the last pour.

For engineered soils and recycled concrete, pH sampling begins when engineered soils or recycled concrete are first exposed to precipitation and continues until the area is fully stabilized.

If the measured pH is 8.5 or greater, the following measures will be taken:

1. Prevent high pH water from entering storm sewer systems or surface water.
2. Adjust or neutralize the high pH water to the range of 6.5 to 8.5 su using appropriate technology such as carbon dioxide (CO₂) sparging (liquid or dry ice).
3. Written approval will be obtained from Ecology prior to the use of chemical treatment other than CO₂ sparging or dry ice.

Method for sampling pH: pH meter, pH test kit, or wide range pH indicator paper

14.0 Conclusion

This analysis is based on data and records either supplied to or obtained by AHBL, Inc. These documents are referenced within the text of the analysis. The analysis has been prepared utilizing procedures and practices within the standard accepted practices of the industry. We conclude that this project, as proposed, will not create any new problems within the existing downstream drainage system. This project will not noticeably aggravate any existing downstream problems due to either water quality or quantity.

AHBL, Inc.

Christopher Watt
Project Engineer

CJW/

October 2023
Revised February 2024

\\ahbl.com\data\Projects\2023\2230752\10_CIV\NON_CAD\REPORTS\SWPPP\20231021 Rpt (CSWPPP) 2230752.10.docx

Appendix F



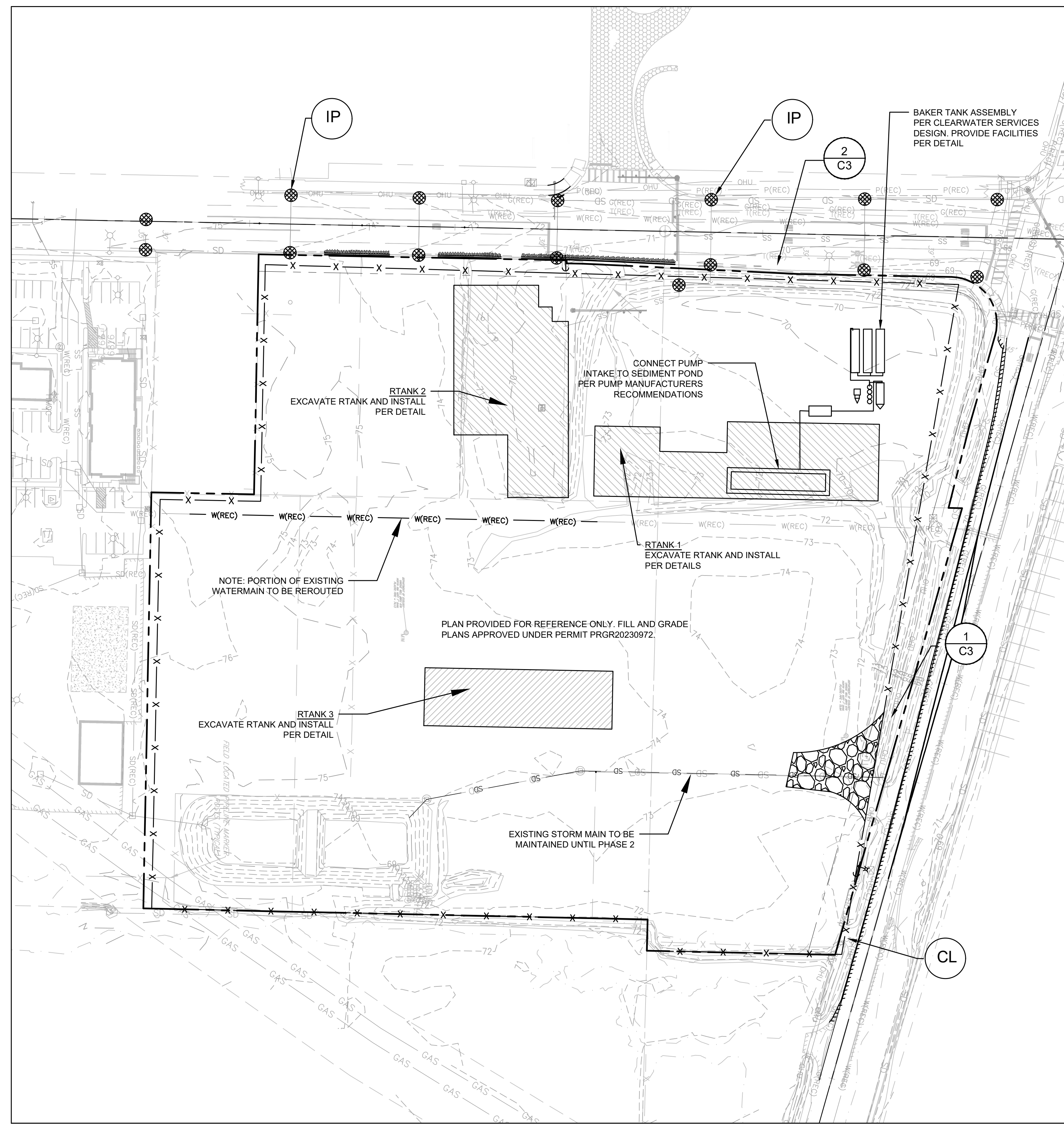
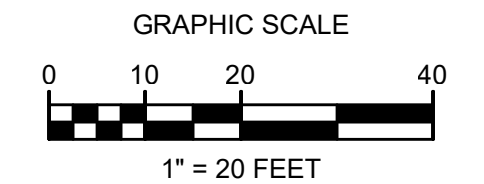
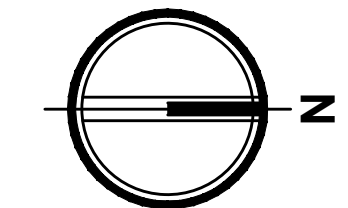

F-1 TESC Plan
F-2 TESC Notes and Details



NOTE:

MAINTAIN SEDIMENT POND AND BAKER TANKS AS DESIGNED IN CLEAR, FILL AND GRADE PLANS PER CFG APPLICATION NUMBER PRGR20230972

TESC LEGEND:

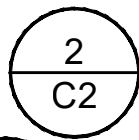
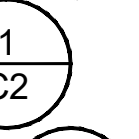
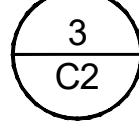
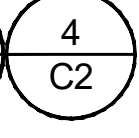
-  CLEARING/ GRADING/ DISTURBED LIMITS
-  FILTER FABRIC FENCE SEE DETAIL
-  CONSTRUCTION ENTRANCE
-  INLET PROTECTION
-  2 C3
-  1 C2
-  3 C2
-  4 C2



Civil Engineers
Structural Engineers
Landscape Architects
Community Planners
Land Surveyors
Historians

TESC PLAN
EAST TOWN CROSSING

TESC INSPECTION NOTES:

- INSPECT ALL INLET PROTECTION ON CATCH BASINS. CLEAN OR REPLACE IF FULL OF SEDIMENT /DEBRIS AND REPAIR/REPLACE AS NEEDED IF DAMAGED TO MAINTAIN PROTECTION.
- INSPECT ALL PERMANENT AND TEMPORARY STABILIZED SLOPES. REPAIR ANY DAMAGED SECTIONS AND RE-VEGETATE AS NEEDED TO ENSURE THE ESTABLISHMENT OF VEGETATION AND THAT NO EROSION OF THE SLOPES OCCUR.
- INSPECT ALL FILTER FABRIC FENCING FOR SIGNS OF EROSION, DAMAGE OR FAILURES. REPAIR AND/OR REPLACE AS NEEDED. SEE FILTER FABRIC NOTES. SEDIMENT BUILD-UP ALONG FENCE SHALL BE REMOVED WHEN REACHES 1/3 THE FENCE HEIGHT. IF EROSION IS OCCURRING, CONTRACTOR SHALL INSTALL ADDITIONAL EROSION CONTROL MEASURES AS NEEDED TO PREVENT EROSION.
- ANY FILLCUT SLOPES SHALL BE INSPECTED FOR EROSION. IF SIGNS OF EROSION ARE PRESENT, INSTALL APPROPRIATE BMPs AS NEEDED TO STOP EROSION AND STABILIZE SLOPES.
- TESC LEAD RESPONSIBLE FOR NOTIFYING ENGINEER IF ADDITIONAL MEASURES ARE WARRANTED.

PERMANENT STABILIZATION NOTES:

- ALL EXPOSED SOILS AND SLOPES SHALL BE SEED OR OTHERWISE STABILIZED IMMEDIATELY AFTER CONSTRUCTION AND GRADING ACTIVITIES HAVE BEEN COMPLETED.
- SILT FENCE, IF DEEMED APPROPRIATE, SHALL REMAIN FOR A MINIMUM OF 30 DAYS AFTER THE FINAL STABILIZATION OF THE SLOPES HAS OCCURRED.
- ALL TEMPORARY EROSION CONTROL BMPs SHALL BE REMOVED 30 DAYS AFTER FINAL STABILIZATION HAS OCCURRED AS DIRECTED BY CITY OR COUNTY INSPECTOR.
- CONTRACTOR SHALL REFER TO THE CONSTRUCTION SWPPP FOR APPLICABLE BMPs.

CONSTRUCTION ENTRANCE NOTES:

- MATERIAL SHALL BE 4" TO 8" QUARRY SPALLS (4 TO 6 INCH FOR RESIDENTIAL SINGLE FAMILY LOTS) AND MAY BE TOP-DRESSED WITH 1 TO 3 INCH ROCK.
- THE ROCK PAD SHALL BE AT LEAST 12" THICK AND 100' LONG (REDUCED TO 20 FEET FOR SITES LESS THAN 1 ACRE OF DISTURBED SOIL) WIDTH SHALL BE FULL WIDTH OF INGRESS AND EGRESS AREA. SMALLER PADS MAY BE APPROVED FOR SINGLE-FAMILY RESIDENTIAL AND COMMERCIAL SITES.
- ADDITIONAL ROCK SHALL BE ADDED PERIODICALLY TO MAINTAIN FUNCTION OF THE PAD.
- IF THE PAD DOES NOT ADEQUATELY REMOVE MUD FROM THE VEHICLE WHEELS, THE WHEELS SHALL BE HOSED OFF BEFORE THE VEHICLE ENTERS A PAVED STREET. THE WASHING SHALL BE DONE ON AN AREA COVERED WITH CRUSHED ROCK AND WASH WATER SHALL DRAIN TO A SEDIMENT RETENTION FACILITY OR THROUGH A SILT FENCE.
- CONSTRUCTION ACCESS IS FORBIDDEN ALONG SHAW ROAD FOR THE DURATION OF CONSTRUCTION.

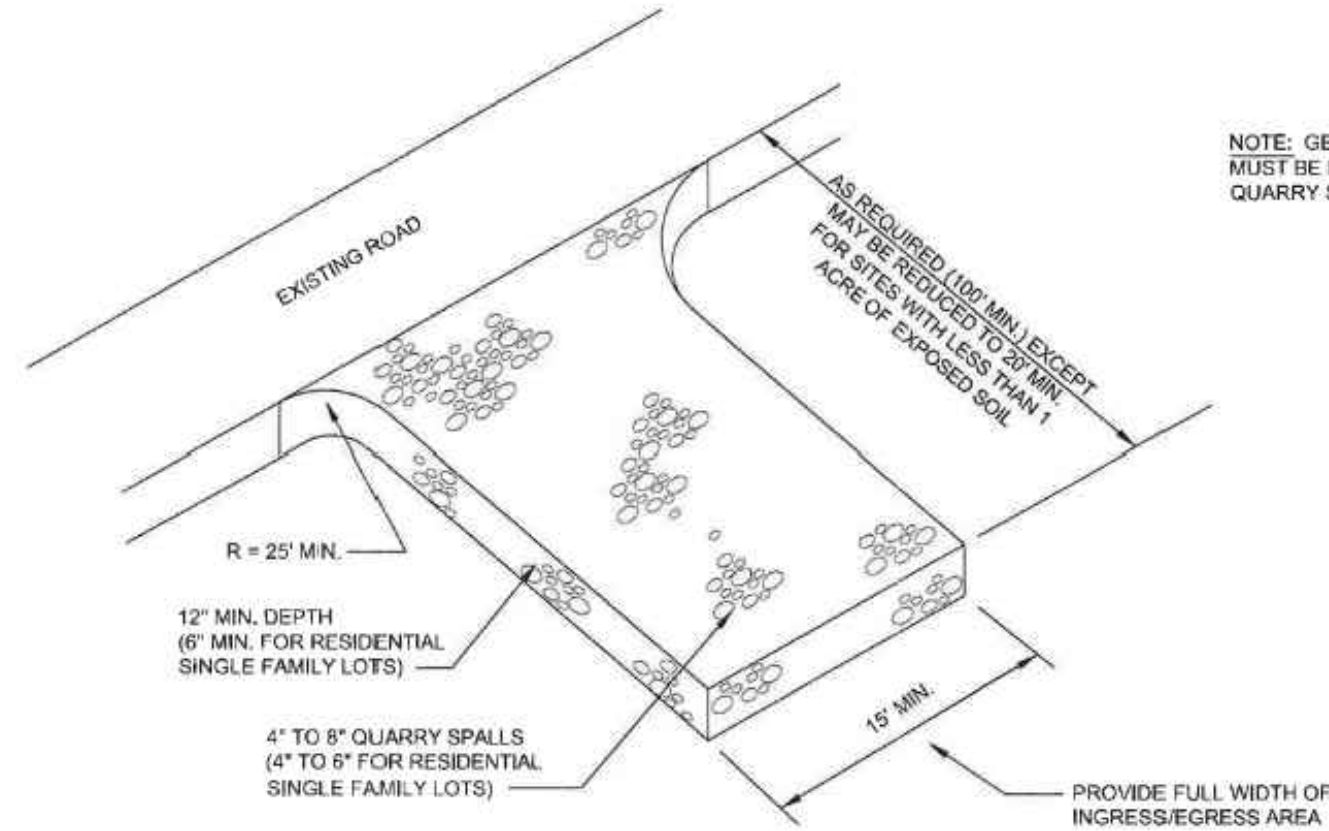

1 CONSTRUCTION ENTRANCE SCALE:NTS

FILTER FABRIC FENCE NOTES:

- SUPPORT POST, WITH A MINIMUM 8-INCH OVERLAP, AND SECURELY FASTENED AT BOTH ENDS TO POSTS.
- POSTS SHALL BE SPACED A MAXIMUM OF 6 FEET APART AND DRIVEN SECURELY INTO THE GROUND (MINIMUM OF 30 INCHES).
- A TRENCH SHALL BE EXCAVATED APPROXIMATELY 8 INCHES WIDE AND 12 INCHES DEEP ALONG THE LINE OF POSTS AND UPSLOPE FROM THE BARRIER. THIS TRENCH SHALL BE BACKFILLED WITH WASHED GRAVEL.
- WHEN STANDARD STRENGTH FILTER FABRIC IS USED, A WIRE MESH SUPPORT FENCE SHALL BE FASTENED SECURELY TO THE UPSLOPE SIDE OF THE POSTS USING HEAVY-DUTY WIRE STAPLES AT LEAST 1 INCH LONG, TIE WIRES OR HOG RINGS. THE WIRE SHALL EXTEND INTO THE TRENCH A MINIMUM OF 4 INCHES AND SHALL NOT EXTEND MORE THAN 24 INCHES ABOVE THE ORIGINAL GROUND SURFACE.
- THE STANDARD STRENGTH FILTER FABRIC SHALL BE STAPLED OR WIRED TO THE FENCE, AND 20 INCHES OF THE FABRIC SHALL BE EXTENDED INTO THE TRENCH. THE FABRIC SHALL NOT EXTEND MORE THAN 24 INCHES ABOVE THE ORIGINAL GROUND SURFACE. FILTER FABRIC SHALL NOT BE STAPLED TO EXISTING TREES.
- WHEN EXTRA-STRENGTH FILTER FABRIC AND CLOSER POST SPACING IS USED, THE WIRE MESH SUPPORT FENCE MAY BE ELIMINATED. IN SUCH A CASE, THE FILTER FABRIC IS STAPLED OR WIRED DIRECTLY TO THE POSTS WITH ALL OTHER PROVISIONS OF ABOVE NOTES APPLYING.
- FILTER FABRIC FENCES SHALL NOT BE REMOVED BEFORE THE UPSLOPE AREA HAS BEEN PERMANENTLY STABILIZED.
- FILTER FABRIC FENCES SHALL BE INSPECTED IMMEDIATELY AFTER EACH RAINFALL AND AT LEAST DAILY DURING PROLONGED RAINFALL. ANY REQUIRED REPAIRS SHALL BE MADE IMMEDIATELY.
- SILT FENCES WILL BE INSTALLED PARALLEL TO ANY SLOPE CONTOURS.
- CONTRIBUTING LENGTH TO FENCE WILL NOT BE GREATER THAN 100 FEET.
- DO NOT INSTALL BELOW AN OUTLET PIPE OR WEIR.
- INSTALL DOWNSLOPE OF EXPOSED AREAS.
- DO NOT DRIVE OVER OR FILL OVER SILT FENCES.

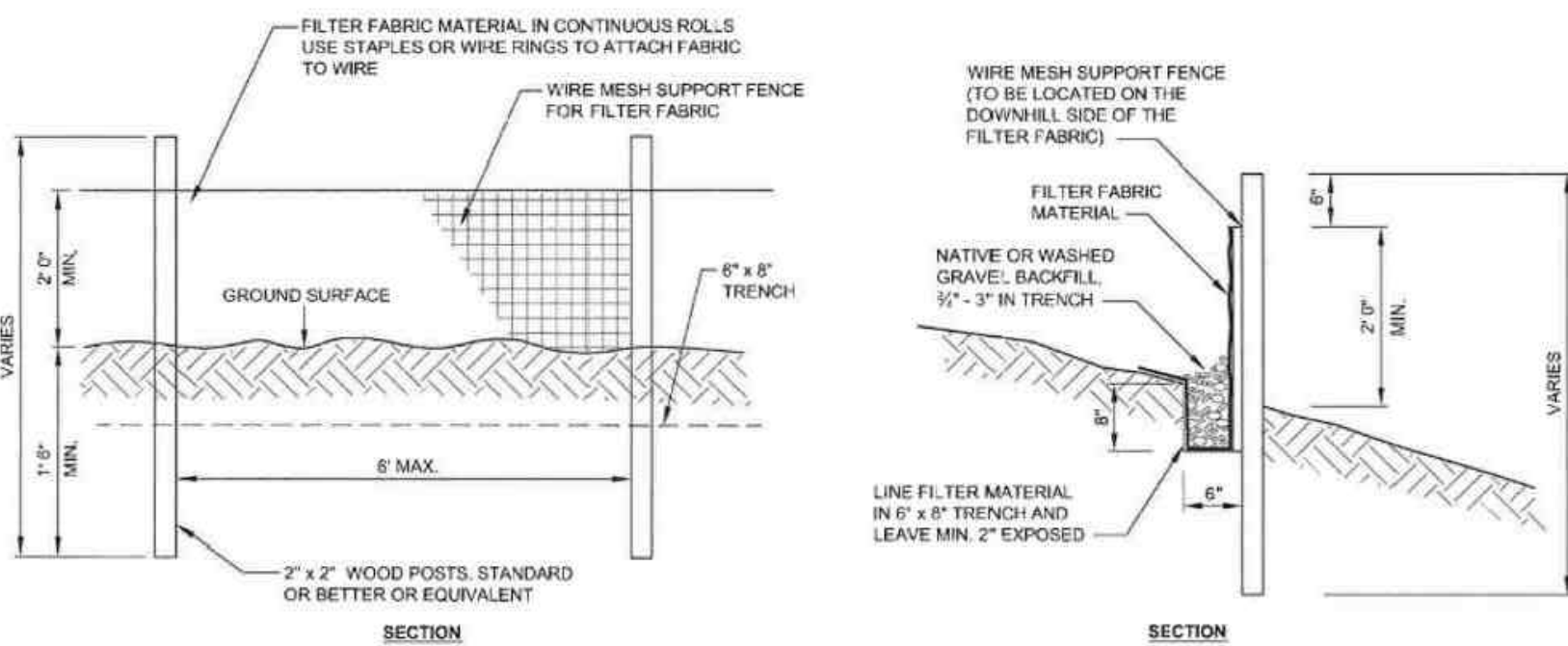

2 FILTER FABRIC FENCE SCALE:NTS

AMENDED SOILS NOTES:

- SOIL AMENDMENTS ARE REQUIRED FOR ALL DISTURBED AREAS IN ACCORDANCE WITH BMP L613: POST-CONSTRUCTION SOIL QUALITY AND DEPTH OF THE 2021 SURFACE WATER MANAGEMENT MANUAL.
- AMENDED SOILS SHALL BE A MINIMUM OF 8" (NON-COMPACTED) WITH SUBSOILS SCARIFIED AT LEAST 4" WITH INCORPORATION OF THE UPPER MATERIAL TO AVOID STRATIFIED LAYERS, WHERE FEASIBLE.
- QUALITY OF COMPOST AND OTHER MATERIALS USED TO MEET THE ORGANIC CONTENT REQUIREMENTS ARE AS FOLLOWS:
 - THE ORGANIC CONTENT FOR "PRE-APPROVED" AMENDMENT RATES CAN BE MET ONLY USING COMPOST THAT MEETS THE DEFINITION OF "COMPOSTED MATERIALS" IN WAC 173-350-220. THE WAC IS AVAILABLE ONLINE AT: [HTTP://WWW.ECY.WA.GOV/PROGRAMS/SWFA/FACILITIES/350.HTML](http://www.ecy.wa.gov/PROGRAMS/SWFA/FACILITIES/350.HTML). THE COMPOST MUST ALSO HAVE AN ORGANIC MATTER CONTENT OF 35% TO 65%, AND A CARBON TO NITROGEN RATIO BELOW 25:1. THE CARBON TO NITROGEN RATIO MAY BE AS HIGH AS 35: 1 FOR PLANTINGS COMPOSED ENTIRELY OF PLANTS NATIVE TO THE PUGET SOUND LOWLANDS REGION.
 - CALCULATED AMENDMENT RATES MAY BE MET THROUGH USE OF COMPOSTED MATERIALS AS DEFINED ABOVE; OR OTHER ORGANIC MATERIALS AMENDED TO MEET THE CARBON TO NITROGEN RATIO REQUIREMENTS, AND MEETING THE CONTAMINANT STANDARDS OF GRADE A COMPOST.
- USE ONE OF THE FOLLOWING OPTIONS TO MEET THE POST CONSTRUCTION SOIL QUALITY AND DEPTH REQUIREMENTS. USE THE MOST RECENT VERSION OF "GUIDELINES FOR RESOURCES FOR IMPLEMENTING SOIL QUALITY AND DEPTH BMP T5.13" TO MEET THE REQUIREMENTS OF THIS BMP. THIS GUIDANCE CAN BE FOUND ONLINE AT: WWW.SOILSFORSALMON.ORG
 - LEAVE NATIVE VEGETATION AND SOIL UNDISTURBED, AND PROTECT FROM COMPACTION DURING CONSTRUCTION.
 - AMEND EXISTING SITE TOPSOIL OR SUBSOIL EITHER AT DEFAULT "PRE-APPROVED" RATES, OR AT CUSTOM CALCULATED RATES BASED ON SPECIFIC TESTS OF THE SOIL AND AMENDMENT.
 - STOCKPILE EXISTING TOPSOIL DURING GRADING, AND REPLACE IT PRIOR TO PLANTING. STOCKPILED TOPSOIL MUST ALSO BE AMENDED IF NEEDED TO MEET THE ORGANIC MATTER OR DEPTH REQUIREMENTS, EITHER AT A DEFAULT "PRE-APPROVED" RATE OR AT A CUSTOM CALCULATED RATE.
 - IMPORT TOPSOIL MIX OF SUFFICIENT ORGANIC CONTENT AND DEPTH TO MEET THE REQUIREMENTS. MORE THAN ONE METHOD MAY BE USED ON DIFFERENT PORTIONS OF THE SAME SITE. SOIL THAT ALREADY MEETS THE DEPTH AND ORGANIC MATTER QUALITY STANDARDS, AND IS NOT COMPACTED, DOES NOT NEED TO BE AMENDED.
- AMENDED SOILS SHALL BE MAINTAINED AS FOLLOWS:
 - SOIL QUALITY AND DEPTH SHOULD BE ESTABLISHED TOWARD THE END OF CONSTRUCTION AND ONCE ESTABLISHED, SHOULD BE PROTECTED FROM COMPACTION, SUCH AS FROM LARGE MACHINERY USE, AND FROM EROSION.
 - SOIL SHOULD BE PLANTED AND MULCHED AFTER INSTALLATION.
 - PLANT DEBRIS OR ITS EQUIVALENT SHOULD BE LEFT ON THE SOIL SURFACE TO REPLENISH ORGANIC MATTER.
 - IT SHOULD BE POSSIBLE TO REDUCE USE OF IRRIGATION, FERTILIZERS, HERBICIDES AND PESTICIDES. THESE ACTIVITIES SHOULD BE ADJUSTED WHERE POSSIBLE, RATHER THAN CONTINUING TO IMPLEMENT FORMERLY ESTABLISHED PRACTICES.
- SEE PROJECT CONSTRUCTION SWPPP FOR ADDITIONAL INFORMATION OR SECTION 2.2.1.4 OF CHAPTER 2 OF VOLUME 6 OF THE 2021 SURFACE WATER MANAGEMENT MANUAL.

MULCHING NOTES:

- MULCH MATERIALS USED SHALL BE STRAW OR HAY, AND SHALL BE APPLIED AT THE RATE OF 75-100 POUNDS PER 1000 SQ. FT. (APPROX 2" THICK).
- MULCH SHALL BE APPLIED IN ALL AREAS WITH EXPOSED SLOPES GREATER THAN 2: 1.
- MULCHING SHALL BE USED IMMEDIATELY AFTER SEEDING OR IN AREAS WHICH CANNOT BE SEEDING BECAUSE OF THE SEASON.
- ALL AREAS NEEDING MULCH SHALL BE COVERED BY NOVEMBER 1.

CONTRACTOR NOTES:

- INLET PROTECTION SHALL BE INSTALLED IN ALL NEWLY CONSTRUCTED CATCH BASINS AND ALONG ALL IMPACTED FRONTAGE AND OFFSITE AREAS PER THE REQUIREMENTS OF THE COUNTY INSPECTOR PER DETAIL 5 ON THIS SHEET.
- CONSTRUCTION FENCE CAN BE UTILIZED IN PLACE OF FILTER FABRIC FENCE ONLY IN AREAS WHERE THE GRADES DO NOT ALLOW THE POTENTIAL FOR ANY STORMWATER TO LEAVE THE SITE.
- ALL DEMOLISHED MATERIALS SHALL BE REMOVED FROM THE SITE AND DISPOSED OF AT A CITY APPROVED LOCATION AND IN A MANNER CONSISTENT WITH CURRENT REGULATIONS AND REQUIREMENTS.
- ALL AREAS THAT WILL BE UNWORKED FOR MORE THAN SEVEN (7) DAYS DURING THE DRY SEASON OR TWO (2) DAYS DURING THE WET SEASON, SHALL BE COVERED WITH STRAW, WOOD FIBER MULCH, COMPOST, PLASTIC SHEETING, OR OTHER EQUIVALENT PER CURRENT CITY OR COUNTY STANDARDS. SEE SEEDING NOTES AND MULCHING NOTES ON THIS SHEET.
- CONTRACTOR SHALL DESIGNATE A WASHINGTON DEPT OF ECOLOGY CERTIFIED EROSION CONTROL LEAD PERSON, AND SHALL COMPLY WITH THE CONSTRUCTION STORMWATER POLLUTION PREVENTION PLAN (SWPPP) PREPARED FOR THE PROJECT.
- AT ANY TIME DURING CONSTRUCTION IT IS DETERMINED BY THE CITY OR COUNTY THAT MUD AND DEBRIS ARE BEING TRACKED ONTO PUBLIC STREETS WITH INSUFFICIENT CLEANUP, ALL WORK SHALL CEASE ON THE PROJECT UNTIL THIS CONDITION IS CORRECTED. THE CONTRACTOR AND/OR THE OWNER SHALL IMMEDIATELY TAKE ALL STEPS NECESSARY TO PREVENT FUTURE TRACKING OF MUD AND DEBRIS INTO THE PUBLIC ROW, WHICH MAY INCLUDE THE INSTALLATION OF A WHEEL WASH FACILITY ON-SITE.
- SEDIMENT LADEN RUNOFF SHALL NOT BE ALLOWED TO DISCHARGE BEYOND THE LIMITS OF THE IMPROVEMENTS. ADDITIONAL MEASURES SHALL BE INSTALLED AS NEEDED.
- SAND BAGS SHALL BE SECURELY PLACED AROUND INSTALLED CATCH BASINS WITH INLET PROTECTION AS FIELD AND WEATHER CONDITIONS WARRANT SO TO PROTECT ALL DISPERSION AND INFILTRATION TRENCHES SEDIMENT LADEN RUNOFF.
- TREES WITHIN WORKING LIMITS TO BE SAVED, SHALL BE MARKED AS SUCH ON SITE AND PROTECTION FENCE PLACED AROUND EACH TREE.

SEEDING NOTES:

- THE FOLLOWING SEED MIXTURE SHALL BE AS BELOW AND SHALL BE APPLIED AT THE RATE RECOMMENDED BY THE SUPPLIER.

TABLE D.3.2.B TEMPORARY EROSION CONTROL SEED MIX			
	% WEIGHT	% PURITY	% GERMINATION
CHEWINGS OR RED FESCUE			
FESTUCA RUBRA VAR. COMMUTATA OR FESTUCA RUBRA	40	98	90
ANNUAL OR PERENNIAL RYE			
LOLIUM MULTIFLORUM OR LOLIUM PERENNE	40	98	90
REDTOP OR COLONIAL BENTGRASS			
AGROSTIS ALBA OR AGROSTIS TENUIS	10	92	85
WHITE DUTCH CLOVER			
TRIFOLIUM REPENS	10	98	90

- SEED BEDS PLANTED BETWEEN MAY 1 AND OCTOBER 31 WILL REQUIRE IRRIGATION AND OTHER MAINTENANCE AS NECESSARY TO FOSTER AND PROTECT THE ROOT STRUCTURE.
- FOR SEED BEDS PLANTED BETWEEN OCTOBER 31 AND APRIL 30, ARMORING OF THE SEED BED WILL BE NECESSARY. (E.G., GEOTEXTILES, JUTE MAT, CLEAR PLASTIC COVERING).
- BEFORE SEEDING, INSTALL NEEDED SURFACE RUNOFF CONTROL MEASURES SUCH AS GRADIENT TERRACES, INTERCEPTOR DIKES, SWALES, LEVEL SPREADERS AND SEDIMENT BASINS.
- THE SEEDBED SHALL BE FIRM WITH A FAIRLY FINE SURFACE, FOLLOWING SURFACE ROUGHENING, PERFORM ALL OPERATIONS ACROSS OR AT RIGHT ANGLES TO THE SLOPE.
- FERTILIZERS ARE TO BE USED ACCORDING TO SUPPLIER'S RECOMMENDATIONS. AMOUNTS USED SHOULD BE MINIMIZED, ESPECIALLY ADJACENT TO WATER BODIES AND WETLANDS.

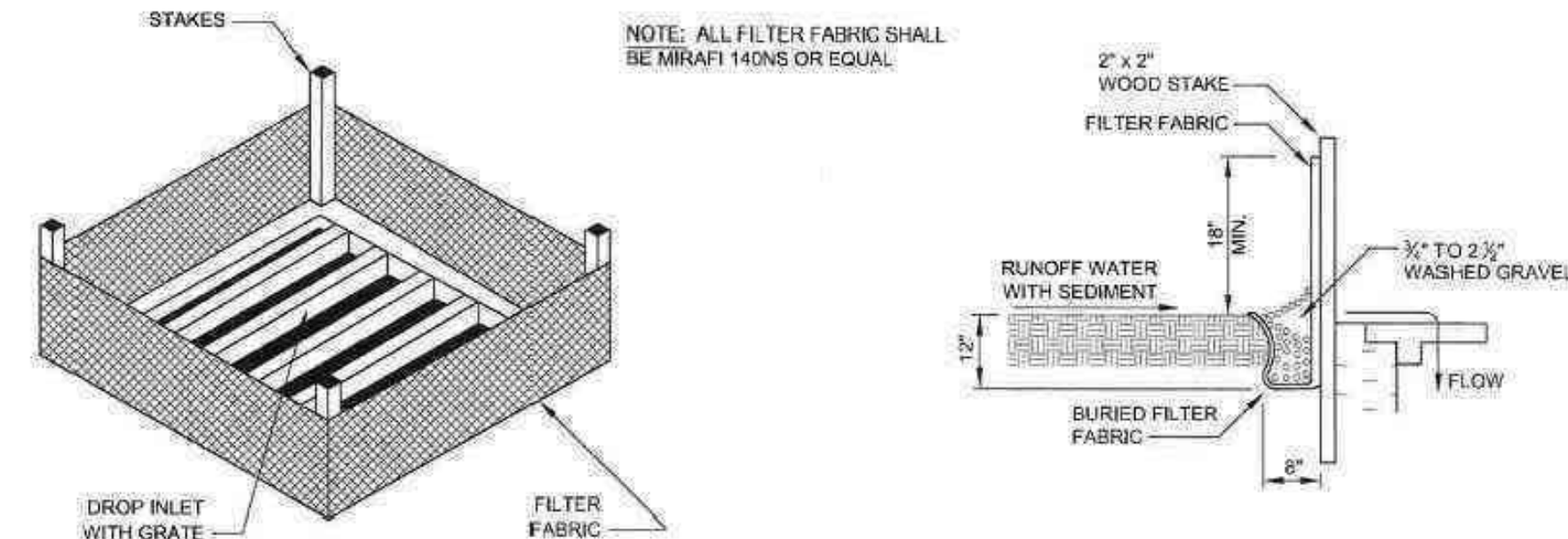

3 INLET PROTECTION WITH FABRIC FENCE SCALE:NTS

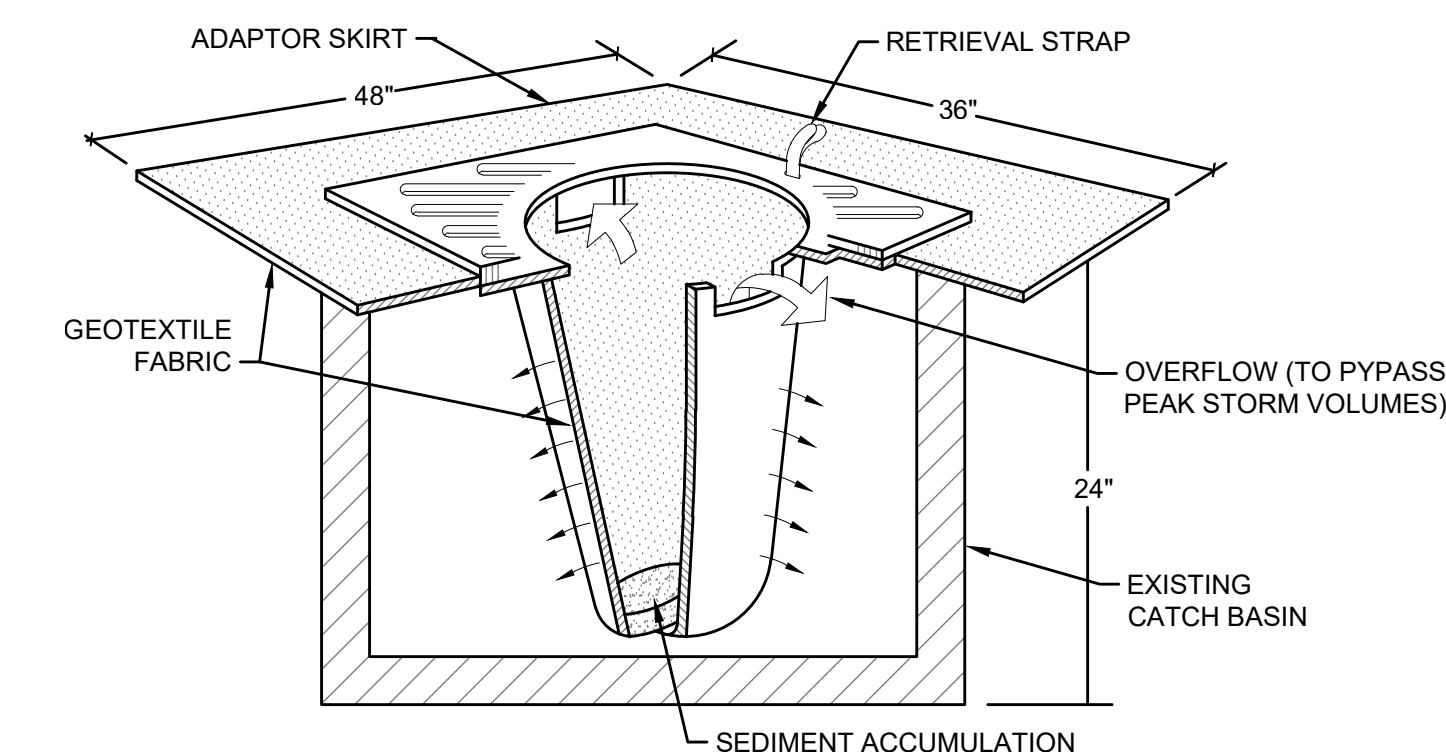

- NOTES:
- FILTERS SHALL BE INSPECTED AFTER EACH STORM EVENT AND CLEANED OR REPLACED WHEN 1/3 FULL.
 - INSTALL INLET PROTECTION IN ALL NEW STORM STRUCTURES THAT WILL COLLECT STORMWATER AS THEY ARE INSTALLED.

4 INLET PROTECTION W/ FILTER SOCK SCALE:NTS



Civil Engineers
Structural Engineers
Landscape Architects
Community Planners
Land Surveyors
Geologists

TESC NOTES AND DETAILS
EAST TOWN CROSSING

Appendix G

Inspection Logs

East Town Crossing
Stormwater Pollution Prevention Plan
Inspection and Maintenance Report Form

To be completed every 7 days and within 24 hours of a rainfall event of 0.5 inches or more

Inspector: _____ Date: _____
 Inspector's Qualifications: _____

Days since last rainfall: _____ Amount of last rainfall: _____ inches

Stabilization Measures

Drainage Area	Date Since Last Disturbance	Date of Next Disturbance	Stabilized (yes/No)	Stabilized With	Condition

Stabilization required: _____

To be performed by: _____ On or before: _____

East Town Crossing
Stormwater Pollution Prevention Plan
Inspection and Maintenance Report Form

Site Entrance:

Date:

Temporary Construction Entrance

Drainage Area Perimeter	Does Rock Pad Adequately Remove Mud from Vehicle Wheels?	Is Rock Pad Clogged with Mud?	Have Quarry Spalls Been Moved to the Roadway?

Maintenance required for temporary construction entrances:

To be performed by: _____ On or before: _____

East Town Crossing
Stormwater Pollution Prevention Plan
Inspection and Maintenance Report Form

Perimeter Structural Controls:

Date:

Silt Fence

Drainage Area Perimeter	Has Silt Reached 1/3 of Fence Height?	Is Fence Properly Secured?	Is There Evidence of Washout or Overtopping?

Maintenance required for silt fence and straw bales:

To be performed by: _____ On or before: _____

East Town Crossing
Stormwater Pollution Prevention Plan
Inspection and Maintenance Report Form

Inlet Protection:

Date:

Storm Drain Barriers

Inlet	Has Silt Reached 1/3 of Barrier Height?	Is Barrier Properly Secured?	Is There Evidence of Washout or Overtopping?

Maintenance required for storm drain barriers:

To be performed by: _____ On or before: _____

East Town Crossing
Stormwater Pollution Prevention Plan
Inspection and Maintenance Report Form

Changes required to the pollution prevention plan:

Reasons for changes:

I certify under penalty of law that this document and all attachments were prepared under my direction or supervision in accordance with a system designed to assure that qualified personnel properly gathered and evaluated the information submitted. Based on my inquiry of the person or persons who manage the system, or those persons directly responsible for gathering the information, the information submitted is, to the best of my knowledge and belief, true, accurate, and complete. I am aware that there are significant penalties for submitting false information, including the possibility of fine and imprisonment for knowing violations.

Signature: _____ Date: _____

Appendix H

Best Management Practices (BMPs)

BMP C102.....	Buffer Zones
BMP C103.....	High Visibility Fence
BMP C105.....	Stabilized Construction Entrance
BMP C107.....	Construction Road / Parking Area Stabilization
BMP C120.....	Temporary and Permanent Seeding
BMP C121.....	Mulching
BMP C122.....	Nets and Blankets
BMP C123.....	Plastic Covering
BMP C140.....	Dust Control
BMP C150.....	Materials on Hand
BMP C151.....	Concrete Handling
BMP C152.....	Sawcutting and Surface Pollution Prevention
BMP C153.....	Material Delivery, Storage, and Containment
BMP C160.....	Certified Erosion and Sediment Control Lead
BMP C209.....	Outlet Protection
BMP C220.....	Storm Drain Inlet Protection
BMP C233.....	Silt Fence
BMP C241.....	Sediment Pond (Temporary)

BMP C102: Buffer Zones

Purpose

Creation of an undisturbed area or strip of natural vegetation or an established suitable planting that will provide a living filter to reduce soil erosion and stormwater runoff velocities.

Conditions of Use

Buffer zones are used along streams, wetlands and other bodies of water that need protection from erosion and sedimentation. Contractors can use vegetative buffer zone BMPs to protect natural swales and they can incorporate them into the natural landscaping of an area.

Do not use critical-areas buffer zones as sediment treatment areas. These areas shall remain completely undisturbed. The local permitting authority may expand the buffer widths temporarily to allow the use of the expanded area for removal of sediment.

The types of buffer zones can change the level of protection required as shown below:

Designated Critical Area Buffers - buffers that protect Critical Areas, as defined by the Washington State Growth Management Act, and are established and managed by the local permitting authority. These should not be disturbed and must be protected with sediment control BMPs to prevent impacts. The local permitting authority may expand the buffer widths temporarily to allow the use of the expanded area for removal of sediment.

Vegetative Buffer Zones - areas that may be identified in undisturbed vegetation areas or managed vegetation areas that are outside any Designated Critical Area Buffer. They may be utilized to provide an additional sediment control area and/or reduce runoff velocities. If being used for preservation of natural vegetation, they should be arranged in clumps or strips. They can be used to protect natural swales and incorporated into the natural landscaping area.

Design and Installation Specifications

- Preserving natural vegetation or plantings in clumps, blocks, or strips is generally the easiest and most successful method.
- Leave all unstable steep slopes in natural vegetation.
- Mark clearing limits and keep all equipment and construction debris out of the natural areas and buffer zones. Steel construction fencing is the most effective method to protect sensitive areas and buffers. Alternatively, wire-backed silt fence on steel posts is marginally effective. Flagging alone is typically not effective.
- Keep all excavations outside the dripline of trees and shrubs.
- Do not push debris or extra soil into the buffer zone area because it will cause damage by

burying and smothering vegetation.

- Vegetative buffer zones for streams, lakes or other waterways shall be established by the local permitting authority or other state or federal permits or approvals.

Maintenance Standards

Inspect the area frequently to make sure flagging remains in place and the area remains undisturbed. Replace all damaged flagging immediately. Remove all materials located in the buffer area that may impede the ability of the vegetation to act as a filter.

BMP C103: High-Visibility Fence

Purpose

High-visibility fencing is intended to:

- Restrict clearing to approved limits.
- Prevent disturbance of sensitive areas, their buffers, and other areas required to be left undisturbed.
- Limit construction traffic to designated construction entrances, exits, or internal roads.
- Protect areas where marking with survey tape may not provide adequate protection.

Conditions of Use

To establish clearing limits plastic, fabric, or metal fence may be used:

- At the boundary of sensitive areas, their buffers, and other areas required to be left uncleared.
- As necessary to control vehicle access to and on the site.

Design and Installation Specifications

High-visibility plastic fence shall be composed of a high-density polyethylene material and shall be at least four feet in height. Posts for the fencing shall be steel or wood and placed every 6 feet on center (maximum) or as needed to ensure rigidity. The fencing shall be fastened to the post every six inches with a polyethylene tie. On long continuous lengths of fencing, a tension wire or rope shall be used as a top stringer to prevent sagging between posts. The fence color shall be high-visibility orange. The fence tensile strength shall be 360 lbs/ft using the ASTM D4595 testing method.

If appropriate install fabric silt fence in accordance with [BMP C233: Silt Fence](#) to act as high-visibility fence. Silt fence shall be at least 3 feet high and must be highly visible to meet the requirements of this BMP.

Metal fences shall be designed and installed according to the manufacturer's specifications.

Metal fences shall be at least 3 feet high and must be highly visible.

Fences shall not be wired or stapled to trees.

Maintenance Standards

If the fence has been damaged or visibility reduced, it shall be repaired or replaced immediately and visibility restored.

BMP C105: Stabilized Construction Access

Purpose

Stabilized construction accesses are established to reduce the amount of sediment transported onto paved roads outside the project site by vehicles or equipment. This is done by constructing a stabilized pad of quarry spalls at entrances and exits for project sites.

Conditions of Use

Construction accesses shall be stabilized wherever traffic will be entering or leaving a construction site if paved roads or other paved areas are within 1,000 feet of the site.

For residential subdivision construction sites, provide a stabilized construction access for each residence, rather than only at the main subdivision entrance. Stabilized surfaces shall be of sufficient length/width to provide vehicle access/parking, based on lot size and configuration.

On large commercial, highway, and road projects, the designer should include enough extra materials in the contract to allow for additional stabilized accesses not shown in the initial Construction SWPPP. It is difficult to determine exactly where access to these projects will take place; additional materials will enable the contractor to install them where needed.

Design and Installation Specifications

See [Figure II-3.1: Stabilized Construction Access](#) for details. Note: the 100' minimum length of the access shall be reduced to the maximum practicable size when the size or configuration of the site does not allow the full length (100').

Construct stabilized construction accesses with a 12-inch thick pad of 4-inch to 8-inch quarry spalls, a 4-inch course of asphalt treated base (ATB), or use existing pavement. Do not use crushed concrete, cement, or calcium chloride for construction access stabilization because these products raise pH levels in stormwater and concrete discharge to waters of the State is prohibited.

A separation geotextile shall be placed under the spalls to prevent fine sediment from pumping up into the rock pad. The geotextile shall meet the standards listed in [Table II-3.2: Stabilized Construction Access Geotextile Standards](#).

**Table II-3.2: Stabilized Construction Access
Geotextile Standards**

Geotextile Property	Required Value
Grab Tensile Strength (ASTM D4751)	200 psi min.

**Table II-3.2: Stabilized Construction Access
Geotextile Standards (continued)**

Geotextile Property	Required Value
Grab Tensile Elongation (ASTM D4632)	30% max.
Mullen Burst Strength (ASTM D3786-80a)	400 psi min.
AOS (ASTM D4751)	20-45 (U.S. standard sieve size)

- Consider early installation of the first lift of asphalt in areas that will be paved; this can be used as a stabilized access. Also consider the installation of excess concrete as a stabilized access. During large concrete pours, excess concrete is often available for this purpose.
- Fencing (see [BMP C 103: High-Visibility Fence](#)) shall be installed as necessary to restrict traffic to the construction access.
- Whenever possible, the access shall be constructed on a firm, compacted subgrade. This can substantially increase the effectiveness of the pad and reduce the need for maintenance.
- Construction accesses should avoid crossing existing sidewalks and back of walk drains if at all possible. If a construction access must cross a sidewalk or back of walk drain, the full length of the sidewalk and back of walk drain must be covered and protected from sediment leaving the site.

Alternative Material Specification

WSDOT has raised safety concerns about the Quarry Spall rock specified above. WSDOT observes that the 4-inch to 8-inch rock sizes can become trapped between Dually truck tires, and then released off-site at highway speeds. WSDOT has chosen to use a modified specification for the rock while continuously verifying that the Stabilized Construction Access remains effective. To remain effective, the BMP must prevent sediment from migrating off site. To date, there has been no performance testing to verify operation of this new specification. Jurisdictions may use the alternative specification, but must perform increased off-site inspection if they use, or allow others to use, it.

Stabilized Construction Accesses may use material that meets the requirements of WSDOT's *Standard Specifications for Road, Bridge, and Municipal Construction* Section 9-03.9(1) ([WSDOT, 2016](#)) for ballast except for the following special requirements.

The grading and quality requirements are listed in [Table II-3.3: Stabilized Construction Access Alternative Material Requirements](#).

**Table II-3.3: Stabilized
Construction Access
Alternative Material
Requirements**

Sieve Size	Percent Passing
2½"	99-100

**Table II-3.3: Stabilized
Construction Access
Alternative Material
Requirements
(continued)**

Sieve Size	Percent Passing
2"	65-100
¾"	40-80
No. 4	5 max.
No. 100	0-2
% Fracture	75 min.

- All percentages are by weight.
- The sand equivalent value and dust ratio requirements do not apply.
- The fracture requirement shall be at least one fractured face and will apply the combined aggregate retained on the No. 4 sieve in accordance with FOP for AASHTO T 335.

Maintenance Standards

Quarry spalls shall be added if the pad is no longer in accordance with the specifications.

- If the access is not preventing sediment from being tracked onto pavement, then alternative measures to keep the streets free of sediment shall be used. This may include replacement/cleaning of the existing quarry spalls, street sweeping, an increase in the dimensions of the access, or the installation of [BMP C106: Wheel Wash](#).
- Any sediment that is tracked onto pavement shall be removed by shoveling or street sweeping. The sediment collected by sweeping shall be removed or stabilized on site. The pavement shall not be cleaned by washing down the street, except when high efficiency sweeping is ineffective and there is a threat to public safety. If it is necessary to wash the streets, the construction of a small sump to contain the wash water shall be considered. The sediment would then be washed into the sump where it can be controlled.
- Perform street sweeping by hand or with a high efficiency sweeper. Do not use a non-high efficiency mechanical sweeper because this creates dust and throws soils into storm systems or conveyance ditches.
- Any quarry spalls that are loosened from the pad, which end up on the roadway shall be removed immediately.
- If vehicles are entering or exiting the site at points other than the construction access(es), [BMP C103: High-Visibility Fence](#) shall be installed to control traffic.

- Upon project completion and site stabilization, all construction accesses intended as permanent access for maintenance shall be permanently stabilized.

Figure II-3.1: Stabilized Construction Access

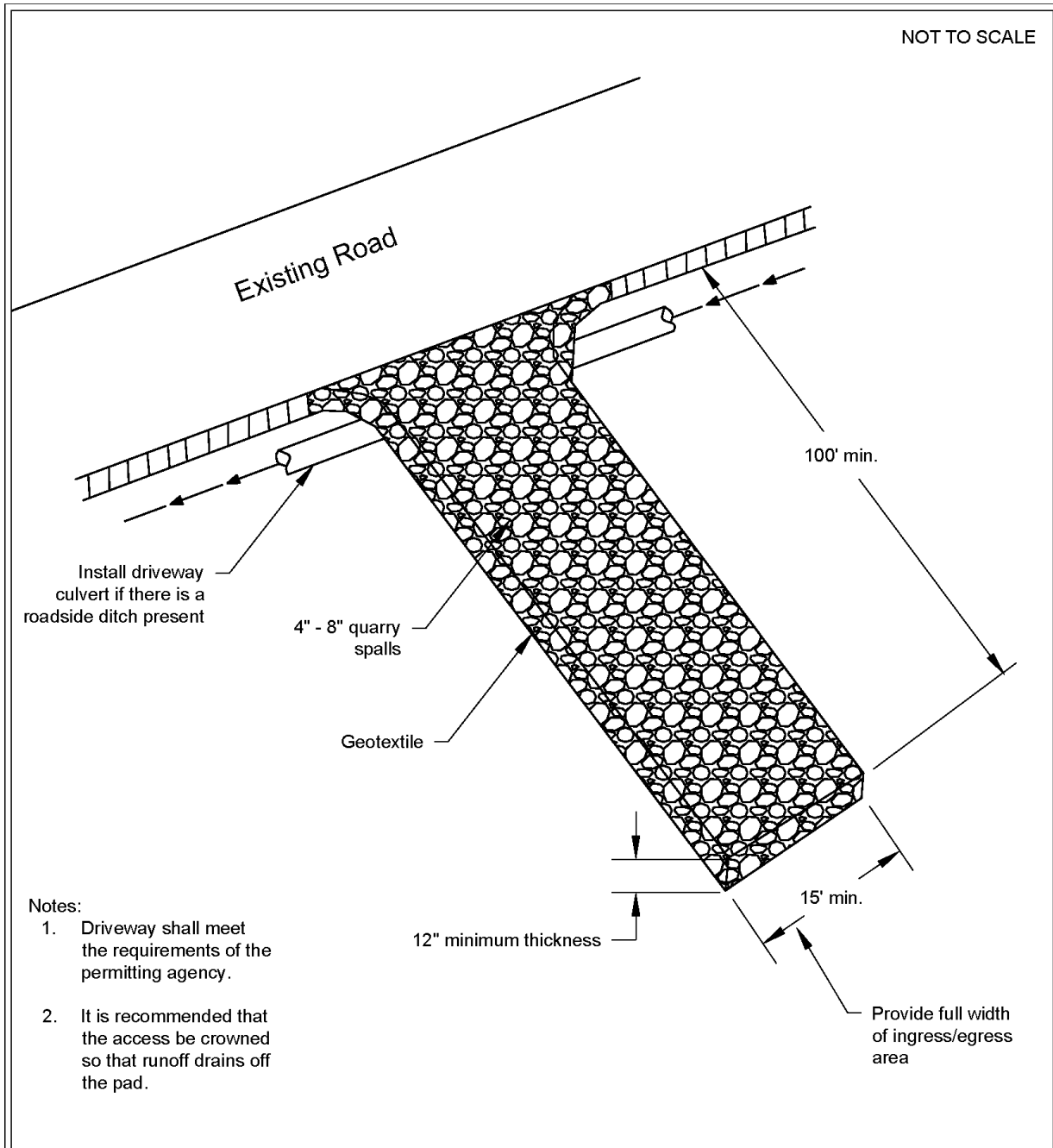

DEPARTMENT OF
ECOLOGY
State of Washington

Stabilized Construction Access

Revised June 2018

Please see <http://www.ecy.wa.gov/copyright.html> for copyright notice including permissions, limitation of liability, and disclaimer.

Approved as Functionally Equivalent

Ecology has approved products as able to meet the requirements of this BMP. The products did not pass through the Technology Assessment Protocol – Ecology (TAPE) process. Local jurisdictions may choose not to accept these products, or may require additional testing prior to consideration for local use. Products that Ecology has approved as functionally equivalent are available for review on Ecology's website at:

<https://ecology.wa.gov/Regulations-Permits/Guidance-technical-assistance/Stormwater-permittee-guidance-resources/Emerging-stormwater-treatment-technologies>

BMP C107: Construction Road / Parking Area Stabilization

Purpose

Stabilizing roads, parking areas, and other on-site vehicle transportation routes immediately after grading reduces erosion caused by construction traffic or stormwater runoff.

Conditions of Use

Roads and parking areas shall be stabilized wherever they are constructed, whether permanent or temporary, for use by construction traffic.

[BMP C103: High-Visibility Fence](#) shall be installed, if necessary, to limit the access of vehicles to only those roads and parking areas that are stabilized.

Design and Installation Specifications

- On areas that will receive asphalt as part of the project, install the first lift as soon as possible.
- A 6-inch depth of 2- to 4-inch crushed rock, gravel base, or crushed surfacing base course shall be applied immediately after grading or utility installation. A 4-inch course of asphalt treated base (ATB) may also be used, or the road/parking area may be paved. It may also be possible to use cement or calcium chloride for soil stabilization. If cement or cement kiln dust is used for roadbase stabilization, pH monitoring and [BMP C252: Treating and Disposing of High pH Water](#) is necessary to evaluate and minimize the effects on stormwater. If the area will not be used for permanent roads, parking areas, or structures, a 6-inch depth of hog fuel may also be used, but this is likely to require more maintenance. Whenever possible, construction roads and parking areas shall be placed on a firm, compacted subgrade.
- Temporary road gradients shall not exceed 15 percent. Roadways shall be carefully graded to drain. Drainage ditches shall be provided on each side of the roadway in the case of a crowned section, or on one side in the case of a super-elevated section. Drainage ditches shall be directed to a sediment control BMP.
- Rather than relying on ditches, it may also be possible to grade the road so that runoff sheetflows into a heavily vegetated area with a well-developed topsoil. Landscaped areas are not adequate. If this area has at least 50 feet of vegetation that water can flow through, then it is generally preferable to use the vegetation to treat runoff, rather than a sediment pond or trap. The 50 feet shall not include wetlands or their buffers. If runoff is allowed to sheetflow through adjacent vegetated areas, it is vital to design the roadways and parking areas so that no concentrated runoff is created.
- Storm drain inlets shall be protected to prevent sediment-laden water entering the drainage system (see [BMP C220: Inlet Protection](#)).

Maintenance Standards

Inspect stabilized areas regularly, especially after large storm events.

Crushed rock, gravel base, etc., shall be added as required to maintain a stable driving surface and to stabilize any areas that have eroded.

Following construction, these areas shall be restored to pre-construction condition or better to prevent future erosion.

Perform street cleaning at the end of each day or more often if necessary.

BMP C120: Temporary and Permanent Seeding

Purpose

Seeding reduces erosion by stabilizing exposed soils. A well-established vegetative cover is one of the most effective methods of reducing erosion.

Conditions of Use

Use seeding throughout the project on disturbed areas that have reached final grade or that will remain unworked for more than 30 days.

The optimum seeding windows for western Washington are April 1 through June 30 and September 1 through October 1.

Between July 1 and August 30 seeding requires irrigation until 75 percent grass cover is established.

Between October 1 and March 30 seeding requires a cover of mulch or an erosion control blanket until 75 percent grass cover is established.

Review all disturbed areas in late August to early September and complete all seeding by the end of September. Otherwise, vegetation will not establish itself enough to provide more than average protection.

Mulch is required at all times for seeding because it protects seeds from heat, moisture loss, and transport due to runoff. Mulch can be applied on top of the seed or simultaneously by hydroseeding. See [BMP C121: Mulching](#) for specifications.

Seed and mulch all disturbed areas not otherwise vegetated at final site stabilization. Final stabilization means the completion of all soil disturbing activities at the site and the establishment of a permanent vegetative cover, or equivalent permanent stabilization measures (such as pavement, riprap, gabions, or geotextiles) which will prevent erosion. See [BMP T5.13: Post-Construction Soil Quality and Depth](#).

Design and Installation Specifications

General

- Install channels intended for vegetation before starting major earthwork and hydroseed with a Bonded Fiber Matrix. For vegetated channels that will have high flows, install erosion control blankets over the top of hydroseed. Before allowing water to flow in vegetated channels, establish 75 percent vegetation cover. If vegetated channels cannot be established by seed

before water flow; install sod in the channel bottom — over top of hydromulch and erosion control blankets.

- Confirm the installation of all required surface water control measures to prevent seed from washing away.
- Hydroseed applications shall include a minimum of 1,500 pounds per acre of mulch with 3 percent tackifier. See [BMP C121: Mulching](#) for specifications.
- Areas that will have seeding only and not landscaping may need compost or meal-based mulch included in the hydroseed in order to establish vegetation. Re-install native topsoil on the disturbed soil surface before application. See [BMP T5.13: Post-Construction Soil Quality and Depth](#).
- When installing seed via hydroseeding operations, only about 1/3 of the seed actually ends up in contact with the soil surface. This reduces the ability to establish a good stand of grass quickly. To overcome this, consider increasing seed quantities by up to 50 percent.
- Enhance vegetation establishment by dividing the hydromulch operation into two phases:
 - Phase 1- Install all seed and fertilizer with 25-30 percent mulch and tackifier onto soil in the first lift.
 - Phase 2- Install the rest of the mulch and tackifier over the first lift.

Or, enhance vegetation by:

- Installing the mulch, seed, fertilizer, and tackifier in one lift.
- Spread or blow straw over the top of the hydromulch at a rate of 800-1000 pounds per acre.
- Hold straw in place with a standard tackifier.

Both of these approaches will increase cost moderately but will greatly improve and enhance vegetative establishment. The increased cost may be offset by the reduced need for:

- Irrigation.
- Reapplication of mulch.
- Repair of failed slope surfaces.

This technique works with standard hydromulch (1,500 pounds per acre minimum) and Bonded Fiber Matrix/ Mechanically Bonded Fiber Matrix (BFM/MBFMs) (3,000 pounds per acre minimum).

- Seed may be installed by hand if:
 - Temporary and covered by straw, mulch, or topsoil.
 - Permanent in small areas (usually less than 1 acre) and covered with mulch, topsoil, or erosion blankets.
- The seed mixes listed in [Table II-3.4: Temporary and Permanent Seed Mixes](#) include

recommended mixes for both temporary and permanent seeding.

- Apply these mixes, with the exception of the wet area seed mix, at a rate of 120 pounds per acre. This rate can be reduced if soil amendments or slow-release fertilizers are used. Apply the wet area seed mix at a rate of 60 pounds per acre.
- Consult the local suppliers or the local conservation district for their recommendations. The appropriate mix depends on a variety of factors, including location, exposure, soil type, slope, and expected foot traffic. Alternative seed mixes approved by the local authority may be used, depending on the soil type and hydrology of the area.

Table II-3.4: Temporary and Permanent Seed Mixes

Common Name	Latin Name	% Weight	% Purity	% Germination
Temporary Erosion Control Seed Mix				
A standard mix for areas requiring a temporary vegetative cover.				
Chewings or annual blue grass	<i>Festuca rubra var. commutata</i> or <i>Poa annua</i>	40	98	90
Perennial rye	<i>Lolium perenne</i>	50	98	90
Redtop or colonial bentgrass	<i>Agrostis alba</i> or <i>Agrostis tenuis</i>	5	92	85
White dutch clover	<i>Trifolium repens</i>	5	98	90
Landscaping Seed Mix				
A recommended mix for landscaping seed.				
Perennial rye blend	<i>Lolium perenne</i>	70	98	90
Chewings and red fescue blend	<i>Festuca rubra var. commutata</i> or <i>Festuca rubra</i>	30	98	90
Low-Growing Turf Seed Mix				
A turf seed mix for dry situations where there is no need for watering. This mix requires very little maintenance.				
Dwarf tall fescue (several varieties)	<i>Festuca arundinacea var.</i>	45	98	90
Dwarf perennial rye (Barclay)	<i>Lolium perenne var. barclay</i>	30	98	90
Red fescue	<i>Festuca rubra</i>	20	98	90
Colonial bentgrass	<i>Agrostis tenuis</i>	5	98	90
Bioswale Seed Mix				
A seed mix for bioswales and other intermittently wet areas.				
Tall or meadow fes-	<i>Festuca arundin-</i>	75-80	98	90

Table II-3.4: Temporary and Permanent Seed Mixes (continued)

Common Name	Latin Name	% Weight	% Purity	% Germination
cue	<i>acea</i> or <i>Festuca elatior</i>			
Seaside/Creeping bentgrass	<i>Agrostis palustris</i>	10-15	92	85
Redtop bentgrass	<i>Agrostis alba</i> or <i>Agrostis gigantea</i>	5-10	90	80
Wet Area Seed Mix				
A low-growing, relatively non-invasive seed mix appropriate for very wet areas that are not regulated wetlands. Consult Hydraulic Permit Authority (HPA) for seed mixes if applicable.				
Tall or meadow fescue	<i>Festuca arundinacea</i> or <i>Festuca elatior</i>	60-70	98	90
Seaside/Creeping bentgrass	<i>Agrostis palustris</i>	10-15	98	85
Meadow foxtail	<i>Alepocurus pratensis</i>	10-15	90	80
Alsike clover	<i>Trifolium hybridum</i>	1-6	98	90
Redtop bentgrass	<i>Agrostis alba</i>	1-6	92	85
Meadow Seed Mix				
A recommended meadow seed mix for infrequently maintained areas or non-maintained areas where colonization by native plants is desirable. Likely applications include rural road and utility right-of-way. Seeding should take place in September or very early October in order to obtain adequate establishment prior to the winter months. Consider the appropriateness of clover, a fairly invasive species, in the mix. Amending the soil can reduce the need for clover.				
Redtop or Oregon bentgrass	<i>Agrostis alba</i> or <i>Agrostis oregonensis</i>	20	92	85
Red fescue	<i>Festuca rubra</i>	70	98	90
White dutch clover	<i>Trifolium repens</i>	10	98	90

Roughening and Rototilling

- The seedbed should be firm and rough. Roughen all soil no matter what the slope. Track walk slopes before seeding if engineering purposes require compaction. Backblading or smoothing of slopes greater than 4H:1V is not allowed if they are to be seeded.
- Restoration-based landscape practices require deeper incorporation than that provided by a simple single-pass rototilling treatment. Wherever practical, initially rip the subgrade to improve long-term permeability, infiltration, and water inflow qualities. At a minimum,

permanent areas shall use soil amendments to achieve organic matter and permeability performance defined in engineered soil/landscape systems. For systems that are deeper than 8 inches complete the rototilling process in multiple lifts, or prepare the engineered soil system per specifications and place to achieve the specified depth.

Fertilizers

- Conducting soil tests to determine the exact type and quantity of fertilizer is recommended. This will prevent the over-application of fertilizer.
- Organic matter is the most appropriate form of fertilizer because it provides nutrients (including nitrogen, phosphorus, and potassium) in the least water-soluble form.
- In general, use 10-4-6 N-P-K (nitrogen-phosphorus-potassium) fertilizer at a rate of 90 pounds per acre. Always use slow-release fertilizers because they are more efficient and have fewer environmental impacts. Do not add fertilizer to the hydromulch machine, or agitate, more than 20 minutes before use. Too much agitation destroys the slow-release coating.
- There are numerous products available that take the place of chemical fertilizers. These include several with seaweed extracts that are beneficial to soil microbes and organisms. If 100 percent cottonseed meal is used as the mulch in hydroseed, chemical fertilizer may not be necessary. Cottonseed meal provides a good source of long-term, slow-release, available nitrogen.

Bonded Fiber Matrix and Mechanically Bonded Fiber Matrix

- On steep slopes use Bonded Fiber Matrix (BFM) or Mechanically Bonded Fiber Matrix (MBFM) products. Apply BFM/MBFM products at a minimum rate of 3,000 pounds per acre with approximately 10 percent tackifier. Achieve a minimum of 95 percent soil coverage during application. Numerous products are available commercially. Most products require 24-36 hours to cure before rainfall and cannot be installed on wet or saturated soils. Generally, products come in 40-50 pound bags and include all necessary ingredients except for seed and fertilizer.
- Install products per manufacturer's instructions.
- BFMs and MBFMs provide good alternatives to blankets in most areas requiring vegetation establishment. Advantages over blankets include:
 - BFM and MBFMs do not require surface preparation.
 - Helicopters can assist in installing BFM and MBFMs in remote areas.
 - On slopes steeper than 2.5H:1V, blanket installers may require ropes and harnesses for safety.
 - Installing BFM and MBFMs can save at least \$1,000 per acre compared to blankets.

Maintenance Standards

Reseed any seeded areas that fail to establish at least 75 percent cover (100 percent cover for areas that receive sheet or concentrated flows). If reseeding is ineffective, use an alternate method such as sodding, mulching, nets, or blankets.

- Reseed and protect by mulch any areas that experience erosion after achieving adequate cover. Reseed and protect by mulch any eroded area.
- Supply seeded areas with adequate moisture, but do not water to the extent that it causes run-off.

Approved as Functionally Equivalent

Ecology has approved products as able to meet the requirements of this BMP. The products did not pass through the Technology Assessment Protocol – Ecology (TAPE) process. Local jurisdictions may choose not to accept these products, or may require additional testing prior to consideration for local use. Products that Ecology has approved as functionally equivalent are available for review on Ecology’s website at:

<https://ecology.wa.gov/Regulations-Permits/Guidance-technical-assistance/Stormwater-permittee-guidance-resources/Emerging-stormwater-treatment-technologies>

BMP C121: Mulching

Purpose

Mulching soils provides immediate temporary protection from erosion. Mulch also enhances plant establishment by conserving moisture, holding fertilizer, seed, and topsoil in place, and moderating soil temperatures. There are a variety of mulches that can be used. This section discusses only the most common types of mulch.

Conditions of Use

As a temporary cover measure, mulch should be used:

- For less than 30 days on disturbed areas that require cover.
- At all times for seeded areas, especially during the wet season and during the hot summer months.
- During the wet season on slopes steeper than 3H:1V with more than 10 feet of vertical relief.

Mulch may be applied at any time of the year and must be refreshed periodically.

For seeded areas, mulch may be made up of 100 percent:

- cottonseed meal;
- fibers made of wood, recycled cellulose, hemp, or kenaf;

- compost;
- or blends of these.

Tackifier shall be plant-based, such as guar or alpha plantago, or chemical-based such as polyacrylamide or polymers.

Generally, mulches come in 40-50 pound bags. Seed and fertilizer are added at time of application.

Recycled cellulose may contain polychlorinated biphenyl (PCBs). Ecology recommends that products should be evaluated for PCBs prior to use.

Refer to [BMP C 126: Polyacrylamide \(PAM\) for Soil Erosion Protection](#) for conditions of use. PAM shall not be directly applied to water or allowed to enter a water body.

Any mulch or tackifier product used shall be installed per the manufacturer's instructions.

Design and Installation Specifications

For mulch materials, application rates, and specifications, see [Table II-3.6: Mulch Standards and Guidelines](#). Consult with the local supplier or the local conservation district for their recommendations. Increase the application rate until the ground is 95% covered (i.e. not visible under the mulch layer). Note: Thickness may be increased for disturbed areas in or near sensitive areas or other areas highly susceptible to erosion.

Where the option of "Compost" is selected, it should be a coarse compost that meets the size gradations listed in [Table II-3.5: Size Gradations of Compost as Mulch Material](#) when tested in accordance with Test Method 02.02-B found in *Test Methods for the Examination of Composting and Compost* (Thompson, 2001).

Table II-3.5: Size Gradations of Compost as Mulch Material

Sieve Size	Percent Passing
3"	100%
1"	90% - 100%
3/4"	70% - 100%
1/4"	40% - 100%

Mulch used within the ordinary high-water mark of surface waters should be selected to minimize potential flotation of organic matter. Composted organic materials have higher specific gravities (densities) than straw, wood, or chipped material. Consult the Hydraulic Permit Authority (HPA) for mulch mixes if applicable.

Maintenance Standards

The thickness of the mulch cover must be maintained.

Any areas that experience erosion shall be remulched and/or protected with a net or blanket. If the erosion problem is drainage related, then the problem shall be fixed and the eroded area remulched.

Table II-3.6: Mulch Standards and Guidelines

Mulch Material	Guideline	Description
Straw	Quality Standards	Air-dried; free from undesirable seed and coarse material.
	Application Rates	2"-3" thick; 5 bales per 1,000 sf or 2-3 tons per acre
	Remarks	Cost-effective protection when applied with adequate thickness. Hand-application generally requires greater thickness than blown straw. The thickness of straw may be reduced by half when used in conjunction with seeding. In windy areas straw must be held in place by crimping, using a tackifier, or covering with netting. Blown straw always has to be held in place with a tackifier as even light winds will blow it away. Straw, however, has several deficiencies that should be considered when selecting mulch materials. It often introduces and/or encourages the propagation of weed species and it has no significant long-term benefits. It should also not be used within the ordinary high-water elevation of surface waters (due to flotation).
Hydromulch	Quality Standards	No growth inhibiting factors.
	Application Rates	Approx. 35-45 lbs per 1,000 sf or 1,500 - 2,000 lbs per acre
	Remarks	Shall be applied with hydromulcher. Shall not be used without seed and tackifier unless the application rate is at least doubled. Fibers longer than about 3/4 - 1 inch clog hydromulch equipment. Fibers should be kept to less than 3/4 inch.
Compost	Quality Standards	No visible water or dust during handling. Must be produced per WAC 173-350 , Solid Waste Handling Standards, but may have up to 35% biosolids.
	Application Rates	2" thick min.; approx. 100 tons per acre (approx. 750 lbs per cubic yard)
	Remarks	More effective control can be obtained by increasing thickness to 3". Excellent mulch for protecting final grades until landscaping because it can be directly seeded or tilled into soil as an amendment. Compost used for mulch has a coarser size gradation than compost used for BMP C 125: Topsoiling / Composting or BMP T5.13: Post-Construction Soil Quality and Depth . It is more stable and practical to use in wet areas and during rainy weather conditions. Do not use near wetlands or near phosphorous impaired water bodies.
Chipped Site Vegetation	Quality Standards	Gradations from fines to 6 inches in length for texture, variation, and interlocking properties. Include a mix of various sizes so that the average size is between 2- and 4- inches.
	Application Rates	2" thick min.;

Table II-3.6: Mulch Standards and Guidelines (continued)

Mulch Material	Guideline	Description
	Remarks	This is a cost-effective way to dispose of debris from clearing and grubbing, and it eliminates the problems associated with burning. Generally, it should not be used on slopes above approx. 10% because of its tendency to be transported by runoff. It is not recommended within 200 feet of surface waters. If permanent seeding or planting is expected shortly after mulch, the decomposition of the chipped vegetation may tie up nutrients important to grass establishment. Note: thick application of this material over existing grass, herbaceous species, and some groundcovers could smother and kill vegetation.
Wood-Based Mulch	Quality Standards	No visible water or dust during handling. Must be purchased from a supplier with a Solid Waste Handling Permit or one exempt from solid waste regulations.
	Application Rates	2" thick min.; approx. 100 tons per acre (approx. 750 lbs. per cubic yard)
	Remarks	This material is often called "wood straw" or "hog fuel". The use of mulch ultimately improves the organic matter in the soil. Special caution is advised regarding the source and composition of wood-based mulches. Its preparation typically does not provide any weed seed control, so evidence of residual vegetation in its composition or known inclusion of weed plants or seeds should be monitored and prevented (or minimized).
Wood Strand Mulch	Quality Standards	A blend of loose, long, thin wood pieces derived from native conifer or deciduous trees with high length-to-width ratio.
	Application Rates	2" thick min.
	Remarks	Cost-effective protection when applied with adequate thickness. A minimum of 95-percent of the wood strand shall have lengths between 2 and 10-inches, with a width and thickness between 1/16 and 1/2-inches. The mulch shall not contain resin, tannin, or other compounds in quantities that would be detrimental to plant life. Sawdust or wood shavings shall not be used as mulch. [Specification 9-14.4(4) from the <i>Standard Specifications for Road, Bridge, and Municipal Construction</i> (WSDOT, 2016)

BMP C122: Nets and Blankets

Purpose

Erosion control nets and blankets are intended to prevent erosion and hold seed and mulch in place on steep slopes and in channels so that vegetation can become well established. In addition, some nets and blankets can be used to permanently reinforce turf to protect drainage ways during high flows.

Nets (commonly called matting) are strands of material woven into an open, but high-tensile strength net (for example, coconut fiber matting). Blankets are strands of material that are not tightly woven, but instead form a layer of interlocking fibers, typically held together by a biodegradable or photodegradable netting (for example, excelsior or straw blankets). They generally have lower tensile strength than nets, but cover the ground more completely. Coir (coconut fiber) fabric comes as both nets and blankets.

Conditions of Use

Erosion control netting and blankets shall be made of natural plant fibers unaltered by synthetic materials.

Erosion control nets and blankets should be used:

- To aid permanent vegetated stabilization of slopes 2H:1V or greater and with more than 10 feet of vertical relief.
- For drainage ditches and swales (highly recommended). The application of appropriate netting or blanket to drainage ditches and swales can protect bare soil from channelized runoff while vegetation is established. Nets and blankets also can capture a great deal of sediment due to their open, porous structure. Nets and blankets can be used to permanently stabilize channels and may provide a cost-effective, environmentally preferable alternative to riprap.

Disadvantages of nets and blankets include:

- Surface preparation is required.
- On slopes steeper than 2.5H:1V, net and blanket installers may need to be roped and harnessed for safety.
- They cost at least \$4,000-6,000 per acre installed.

Advantages of nets and blankets include:

- Installation without mobilizing special equipment.
- Installation by anyone with minimal training
- Installation in stages or phases as the project progresses.
- Installers can hand place seed and fertilizer as they progress down the slope.
- Installation in any weather.
- There are numerous types of nets and blankets that can be designed with various parameters in mind. Those parameters include: fiber blend, mesh strength, longevity, biodegradability, cost, and availability.

An alternative to nets and blankets in some limited conditions is [BMP C202: Riprap Channel Lining](#). Ensure that [BMP C202: Riprap Channel Lining](#) is appropriate before using it as a substitute for nets and blankets.

Design and Installation Specifications

- See [Figure II-3.3: Channel Installation \(Clackamas County et al., 2008\)](#) and [Figure II-3.4: Slope Installation](#) for typical orientation and installation of nets and blankets used in channels and as slope protection. Note: these are typical only; all nets and blankets must be installed per manufacturer's installation instructions.
- Installation is critical to the effectiveness of these products. If good ground contact is not achieved, runoff can concentrate under the product, resulting in significant erosion.
- Installation of nets and blankets on slopes:
 1. Complete final grade and track walk up and down the slope.
 2. Install hydromulch with seed and fertilizer.
 3. Dig a small trench, approximately 12 inches wide by 6 inches deep along the top of the slope.
 4. Install the leading edge of the net/blanket into the small trench and staple approximately every 18 inches. NOTE: Staples are metal, "U"-shaped, and a minimum of 6 inches long. Longer staples are used in sandy soils. Biodegradable stakes are also available.
 5. Roll the net/blanket slowly down the slope as the installer walks backward. NOTE: The net/blanket rests against the installer's legs. Staples are installed as the net/blanket is unrolled. It is critical that the proper staple pattern is used for the net/blanket being installed. The net/blanket is not to be allowed to roll down the slope on its own as this stretches the net/blanket, making it impossible to maintain soil contact. In addition, no one is allowed to walk on the net/blanket after it is in place.
 6. If the net/blanket is not long enough to cover the entire slope length, the trailing edge of the upper net/blanket should overlap the leading edge of the lower net/blanket and be stapled. On steeper slopes, this overlap should be installed in a small trench, stapled, and covered with soil.
- With the variety of products available, it is impossible to cover all the details of appropriate use and installation. Therefore, it is critical that the designer consult the manufacturer's information and that a site visit takes place in order to ensure that the product specified is appropriate. Information is also available in WSDOT's *Standard Specifications for Road, Bridge, and Municipal Construction* Division 8-01 and Division 9-14 ([WSDOT, 2016](#)).
- Use jute matting in conjunction with mulch ([BMP C 121: Mulching](#)). Excelsior, woven straw blankets and coir (coconut fiber) blankets may be installed without mulch. There are many other types of erosion control nets and blankets on the market that may be appropriate in certain circumstances.
- In general, most nets (e.g., jute matting) require mulch in order to prevent erosion because they have a fairly open structure. Blankets typically do not require mulch because they usually provide complete protection of the surface.
- Extremely steep, unstable, wet, or rocky slopes are often appropriate candidates for use of synthetic blankets, as are riverbanks, beaches and other high-energy environments. If

synthetic blankets are used, the soil should be hydromulched first.

- 100-percent biodegradable blankets are available for use in sensitive areas. These organic blankets are usually held together with a paper or fiber mesh and stitching which may last up to a year.
- Most netting used with blankets is photodegradable, meaning it breaks down under sunlight (not UV stabilized). However, this process can take months or years even under bright sun. Once vegetation is established, sunlight does not reach the mesh. It is not uncommon to find non-degraded netting still in place several years after installation. This can be a problem if maintenance requires the use of mowers or ditch cleaning equipment. In addition, birds and small animals can become trapped in the netting.

Maintenance Standards

- Maintain good contact with the ground. Erosion must not occur beneath the net or blanket.
- Repair and staple any areas of the net or blanket that are damaged or not in close contact with the ground.
- Fix and protect eroded areas if erosion occurs due to poorly controlled drainage.

Figure II-3.3: Channel Installation

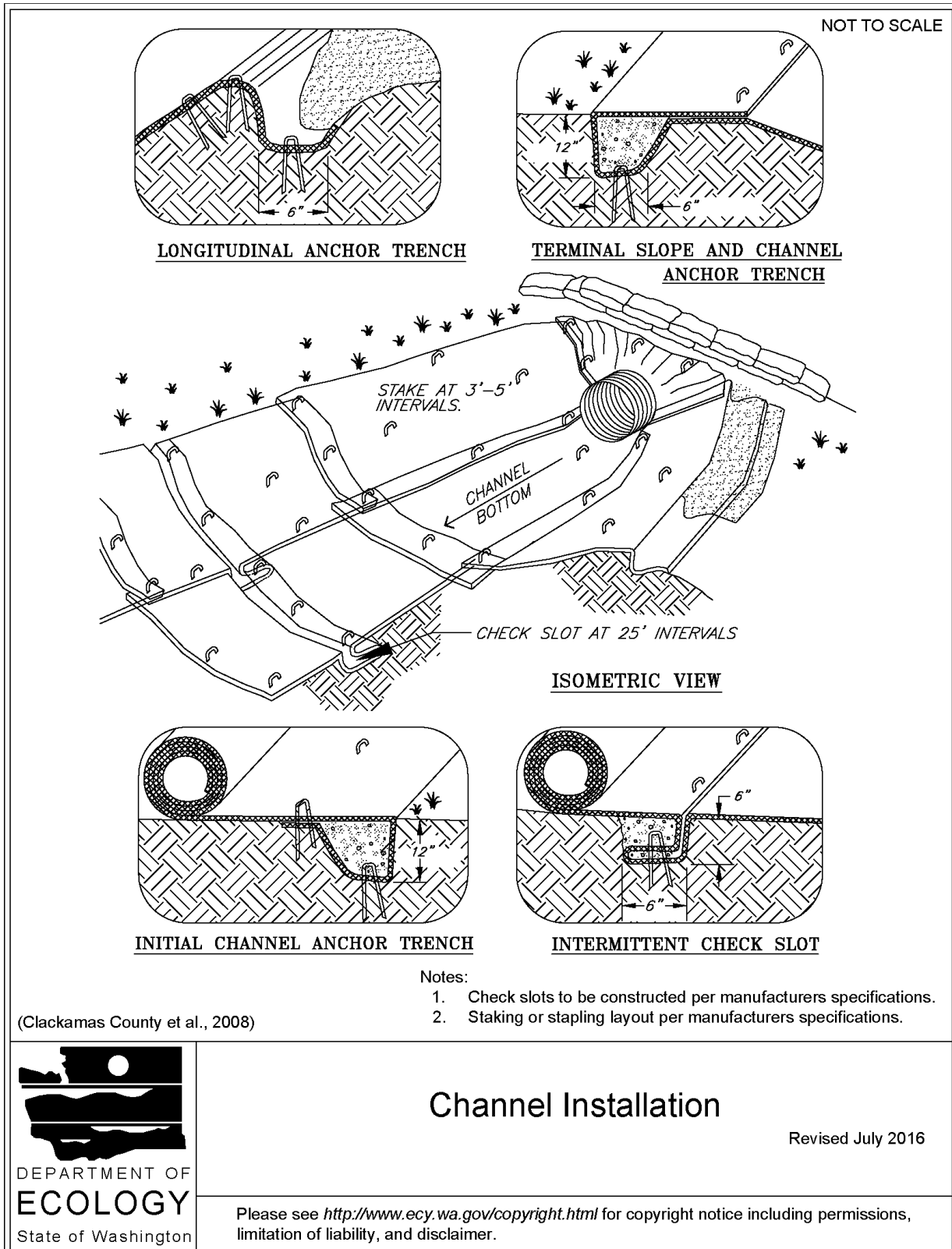
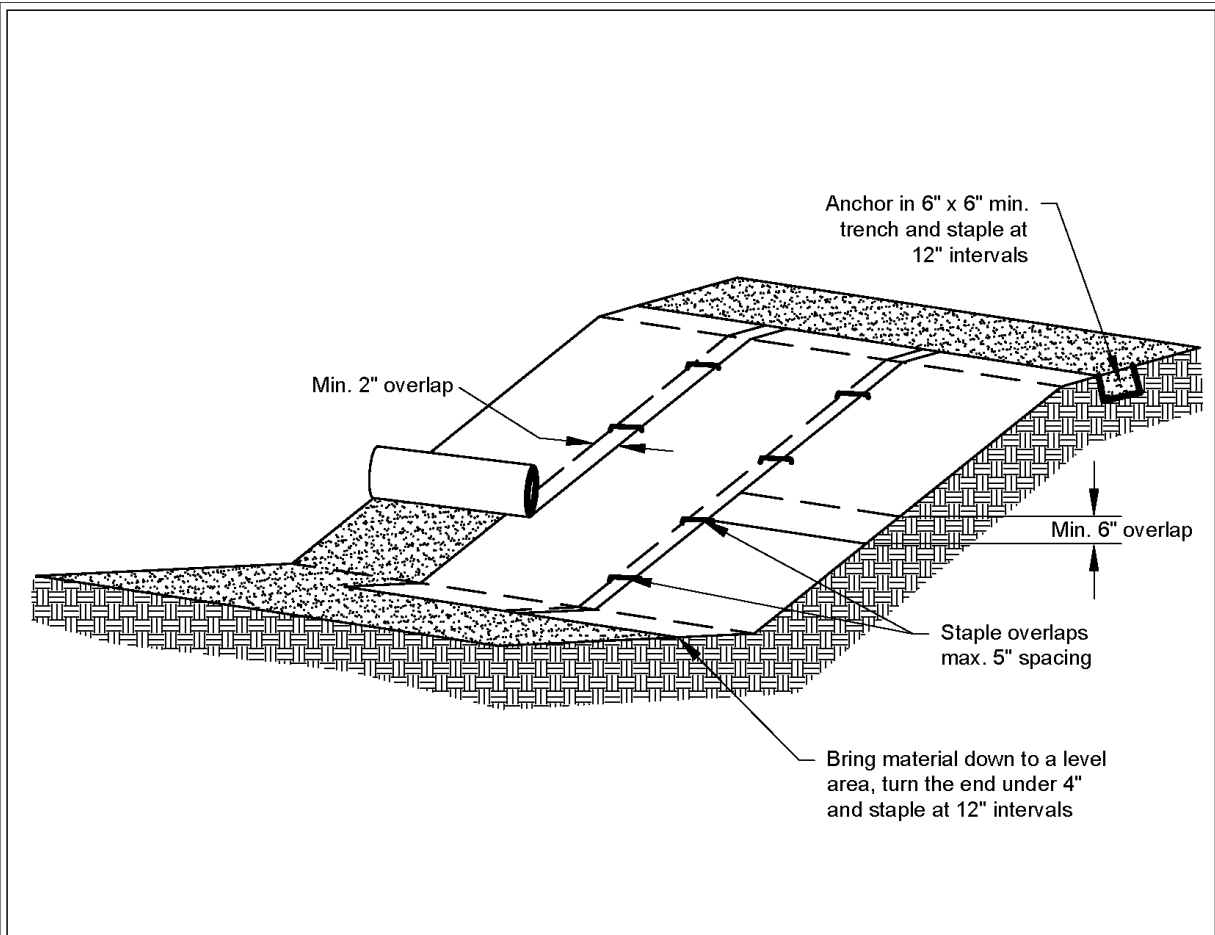

Figure II-3.4: Slope Installation



Notes:

1. Slope surface shall be smooth before placement for proper soil contact.
2. Stapling pattern as per manufacturer's recommendations.
3. Do not stretch blankets/matting tight - allow the rolls to mold to any irregularities.
4. For slopes less than 3H:1V, rolls may be placed in horizontal strips.
5. If there is a berm at the top of the slope, anchor upslope of the berm.
6. Lime, fertilize, and seed before installation. Planting of shrubs, trees, etc. should occur after installation.

NOT TO SCALE



Slope Installation

Revised June 2016

Please see <http://www.ecy.wa.gov/copyright.html> for copyright notice including permissions, limitation of liability, and disclaimer.

BMP C123: Plastic Covering

Purpose

Plastic covering provides immediate, short-term erosion protection to slopes and disturbed areas.

Conditions of Use

Plastic covering may be used on disturbed areas that require cover measures for less than 30 days, except as stated below.

- Plastic is particularly useful for protecting cut and fill slopes and stockpiles. However, the relatively rapid breakdown of most polyethylene sheeting makes it unsuitable for applications greater than six months.
- Due to rapid runoff caused by plastic covering, do not use this method upslope of areas that might be adversely impacted by concentrated runoff. Such areas include steep and/or unstable slopes.
- Plastic sheeting may result in increased runoff volumes and velocities, requiring additional on-site measures to counteract the increases. Creating a trough with wattles or other material can convey clean water away from these areas.
- To prevent undercutting, trench and backfill rolled plastic covering products.
- Although the plastic material is inexpensive to purchase, the cost of installation, maintenance, removal, and disposal add to the total costs of this BMP.
- Whenever plastic is used to protect slopes, install water collection measures at the base of the slope. These measures include plastic-covered berms, channels, and pipes used to convey clean rainwater away from bare soil and disturbed areas. Do not mix clean runoff from a plastic covered slope with dirty runoff from a project.
- Other uses for plastic include:
 - Temporary ditch liner.
 - Pond liner in temporary sediment pond.
 - Liner for bermed temporary fuel storage area if plastic is not reactive to the type of fuel being stored.
 - Emergency slope protection during heavy rains.
 - Temporary drainpipe (“elephant trunk”) used to direct water.

Design and Installation Specifications

- Plastic slope cover must be installed as follows:
 1. Run plastic up and down the slope, not across the slope.
 2. Plastic may be installed perpendicular to a slope if the slope length is less than 10 feet.

3. Provide a minimum of 8-inch overlap at the seams.
 4. On long or wide slopes, or slopes subject to wind, tape all seams.
 5. Place plastic into a small (12-inch wide by 6-inch deep) slot trench at the top of the slope and backfill with soil to keep water from flowing underneath.
 6. Place sand filled burlap or geotextile bags every 3 to 6 feet along seams and tie them together with twine to hold them in place.
 7. Inspect plastic for rips, tears, and open seams regularly and repair immediately. This prevents high velocity runoff from contacting bare soil, which causes extreme erosion.
 8. Sandbags may be lowered into place tied to ropes. However, all sandbags must be staked in place.
- Plastic sheeting shall have a minimum thickness of 0.06 millimeters.
 - If erosion at the toe of a slope is likely, a gravel berm, riprap, or other suitable protection shall be installed at the toe of the slope in order to reduce the velocity of runoff.

Maintenance Standards

- Torn sheets must be replaced and open seams repaired.
- Completely remove and replace the plastic if it begins to deteriorate due to ultraviolet radiation.
- Completely remove plastic when no longer needed.
- Dispose of old tires used to weight down plastic sheeting appropriately.

Approved as Functionally Equivalent

Ecology has approved products as able to meet the requirements of this BMP. The products did not pass through the Technology Assessment Protocol – Ecology (TAPE) process. Local jurisdictions may choose not to accept these products, or may require additional testing prior to consideration for local use. Products that Ecology has approved as functionally equivalent are available for review on Ecology's website at:

<https://ecology.wa.gov/Regulations-Permits/Guidance-technical-assistance/Stormwater-permittee-guidance-resources/Emerging-stormwater-treatment-technologies>

BMP C140: Dust Control

Purpose

Dust control prevents wind transport of dust from disturbed soil surfaces onto roadways, drainage ways, and surface waters.

Conditions of Use

Use dust control in areas (including roadways) subject to surface and air movement of dust where on-site or off-site impacts to roadways, drainage ways, or surface waters are likely.

Design and Installation Specifications

- Vegetate or mulch areas that will not receive vehicle traffic. In areas where planting, mulching, or paving is impractical, apply gravel or landscaping rock.
- Limit dust generation by clearing only those areas where immediate activity will take place, leaving the remaining area(s) in the original condition. Maintain the original ground cover as long as practical.
- Construct natural or artificial windbreaks or windscreens. These may be designed as enclosures for small dust sources.
- Sprinkle the site with water until the surface is wet. Repeat as needed. To prevent carryout of mud onto the street, refer to [BMP C 105: Stabilized Construction Access](#) and [BMP C 106: Wheel Wash](#).
- Irrigation water can be used for dust control. Irrigation systems should be installed as a first step on sites where dust control is a concern.
- Spray exposed soil areas with a dust palliative, following the manufacturer's instructions and cautions regarding handling and application. Used oil is prohibited from use as a dust suppressant. Local governments may approve other dust palliatives such as calcium chloride or PAM.
- PAM ([BMP C 126: Polyacrylamide \(PAM\) for Soil Erosion Protection](#)) added to water at a rate of 0.5 pounds per 1,000 gallons of water per acre and applied from a water truck is more effective than water alone. This is due to increased infiltration of water into the soil and reduced evaporation. In addition, small soil particles are bonded together and are not as easily transported by wind. Adding PAM may reduce the quantity of water needed for dust control. Note that the application rate specified here applies to this BMP, and is not the same application rate that is specified in [BMP C 126: Polyacrylamide \(PAM\) for Soil Erosion Protection](#), but the downstream protections still apply.

Refer to [BMP C 126: Polyacrylamide \(PAM\) for Soil Erosion Protection](#) for conditions of use. PAM shall not be directly applied to water or allowed to enter a water body.

- Contact your local Air Pollution Control Authority for guidance and training on other dust control measures. Compliance with the local Air Pollution Control Authority constitutes

compliance with this BMP.

- Use vacuum street sweepers.
- Remove mud and other dirt promptly so it does not dry and then turn into dust.
- Techniques that can be used for unpaved roads and lots include:
 - Lower speed limits. High vehicle speed increases the amount of dust stirred up from unpaved roads and lots.
 - Upgrade the road surface strength by improving particle size, shape, and mineral types that make up the surface and base materials.
 - Add surface gravel to reduce the source of dust emission. Limit the amount of fine particles (those smaller than .075 mm) to 10 to 20 percent.
 - Use geotextile fabrics to increase the strength of new roads or roads undergoing reconstruction.
 - Encourage the use of alternate, paved routes, if available.
 - Apply chemical dust suppressants using the admix method, blending the product with the top few inches of surface material. Suppressants may also be applied as surface treatments.
 - Limit dust-causing work on windy days.
 - Pave unpaved permanent roads and other trafficked areas.

Maintenance Standards

Respray area as necessary to keep dust to a minimum.

BMP C150: Materials on Hand

Purpose

Keep quantities of erosion prevention and sediment control materials on the project site at all times to be used for regular maintenance and emergency situations such as unexpected heavy rains. Having these materials on-site reduces the time needed to replace existing or implement new BMPs when inspections indicate that existing BMPs are not meeting the Construction SWPPP requirements. In addition, contractors can save money by buying some materials in bulk and storing them at their office or yard.

Conditions of Use

- Construction projects of any size or type can benefit from having materials on hand. A small commercial development project could have a roll of plastic and some gravel available for immediate protection of bare soil and temporary berm construction. A large earthwork project, such as highway construction, might have several tons of straw, several rolls of plastic, flexible

pipe, sandbags, geotextile fabric and steel “T” posts.

- Materials should be stockpiled and readily available before any site clearing, grubbing, or earthwork begins. A large contractor or project proponent could keep a stockpile of materials that are available for use on several projects.
- If storage space at the project site is at a premium, the contractor could maintain the materials at their office or yard. The office or yard must be less than an hour from the project site.

Design and Installation Specifications

Depending on project type, size, complexity, and length, materials and quantities will vary. A good minimum list of items that will cover numerous situations includes:

- Clear Plastic, 6 mil
- Drainpipe, 6 or 8 inch diameter
- Sandbags, filled
- Straw Bales for mulching
- Quarry Spalls
- Washed Gravel
- Geotextile Fabric
- Catch Basin Inserts
- Steel "T" Posts
- Silt fence material
- Straw Wattles

Maintenance Standards

- All materials with the exception of the quarry spalls, steel “T” posts, and gravel should be kept covered and out of both sun and rain.
- Re-stock materials as needed.

BMP C151: Concrete Handling

Purpose

Concrete work can generate process water and slurry that contain fine particles and high pH, both of which can violate water quality standards in the receiving water. Concrete spillage or concrete discharge to waters of the State is prohibited. Use this BMP to minimize and eliminate concrete, concrete process water, and concrete slurry from entering waters of the State.

Conditions of Use

Any time concrete is used, utilize these management practices. Concrete construction project components include, but are not limited to:

- Curbs
- Sidewalks
- Roads
- Bridges
- Foundations
- Floors
- Runways

Disposal options for concrete, in order of preference are:

1. Off-site disposal
2. Concrete wash-out areas (see [BMP C154: Concrete Washout Area](#))
3. De minimus washout to formed areas awaiting concrete

Design and Installation Specifications

- Wash concrete truck drums at an approved off-site location or in designated concrete washout areas only. Do not wash out concrete trucks onto the ground (including formed areas awaiting concrete), or into storm drains, open ditches, streets, or streams. Refer to [BMP C154: Concrete Washout Area](#) for information on concrete washout areas.
 - Return unused concrete remaining in the truck and pump to the originating batch plant for recycling. Do not dump excess concrete on site, except in designated concrete washout areas as allowed in [BMP C154: Concrete Washout Area](#).
- Wash small concrete handling equipment (e.g. hand tools, screeds, shovels, rakes, floats, trowels, and wheelbarrows) into designated concrete washout areas or into formed areas awaiting concrete pour.
- At no time shall concrete be washed off into the footprint of an area where an infiltration feature will be installed.
- Wash equipment difficult to move, such as concrete paving machines, in areas that do not directly drain to natural or constructed stormwater conveyance or potential infiltration areas.
- Do not allow washwater from areas, such as concrete aggregate driveways, to drain directly (without detention or treatment) to natural or constructed stormwater conveyances.
- Contain washwater and leftover product in a lined container when no designated concrete washout areas (or formed areas, allowed as described above) are available. Dispose of contained concrete and concrete washwater (process water) properly.

- Always use forms or solid barriers for concrete pours, such as pilings, within 15-feet of surface waters.
- Refer to [BMP C252: Treating and Disposing of High pH Water](#) for pH adjustment requirements.
- Refer to the Construction Stormwater General Permit (CSWGP) for pH monitoring requirements if the project involves one of the following activities:
 - Significant concrete work (as defined in the CSWGP).
 - The use of soils amended with (but not limited to) Portland cement-treated base, cement kiln dust or fly ash.
 - Discharging stormwater to segments of water bodies on the 303(d) list (Category 5) for high pH.

Maintenance Standards

Check containers for holes in the liner daily during concrete pours and repair the same day.

BMP C152: Sawcutting and Surfacing Pollution Prevention

Purpose

Sawcutting and surfacing operations generate slurry and process water that contains fine particles and high pH (concrete cutting), both of which can violate the water quality standards in the receiving water. Concrete spillage or concrete discharge to waters of the State is prohibited. Use this BMP to minimize and eliminate process water and slurry created through sawcutting or surfacing from entering waters of the State.

Conditions of Use

Utilize these management practices anytime sawcutting or surfacing operations take place. Sawcutting and surfacing operations include, but are not limited to:

- Sawing
- Coring
- Grinding
- Roughening
- Hydro-demolition
- Bridge and road surfacing

Design and Installation Specifications

- Vacuum slurry and cuttings during cutting and surfacing operations.
- Slurry and cuttings shall not remain on permanent concrete or asphalt pavement overnight.
- Slurry and cuttings shall not drain to any natural or constructed drainage conveyance including stormwater systems. This may require temporarily blocking catch basins.
- Dispose of collected slurry and cuttings in a manner that does not violate ground water or surface water quality standards.
- Do not allow process water generated during hydro-demolition, surface roughening or similar operations to drain to any natural or constructed drainage conveyance including stormwater systems. Dispose of process water in a manner that does not violate ground water or surface water quality standards.
- Handle and dispose of cleaning waste material and demolition debris in a manner that does not cause contamination of water. Dispose of sweeping material from a pick-up sweeper at an appropriate disposal site.

Maintenance Standards

Continually monitor operations to determine whether slurry, cuttings, or process water could enter waters of the state. If inspections show that a violation of water quality standards could occur, stop operations and immediately implement preventive measures such as berms, barriers, secondary containment, and/or vacuum trucks.

BMP C153: Material Delivery, Storage, and Containment

Purpose

Prevent, reduce, or eliminate the discharge of pollutants to the stormwater system or watercourses from material delivery and storage. Minimize the storage of hazardous materials on-site, store materials in a designated area, and install secondary containment.

Conditions of Use

Use at construction sites with delivery and storage of the following materials:

- Petroleum products such as fuel, oil and grease
- Soil stabilizers and binders (e.g., Polyacrylamide)
- Fertilizers, pesticides and herbicides
- Detergents
- Asphalt and concrete compounds

- Hazardous chemicals such as acids, lime, adhesives, paints, solvents, and curing compounds
- Any other material that may be detrimental if released to the environment

Design and Installation Specifications

- The temporary storage area should be located away from vehicular traffic, near the construction entrance(s), and away from waterways or storm drains.
- Safety Data Sheets (SDS) should be supplied for all materials stored. Chemicals should be kept in their original labeled containers.
- Hazardous material storage on-site should be minimized.
- Hazardous materials should be handled as infrequently as possible.
- During the wet weather season (Oct 1 – April 30), consider storing materials in a covered area.
- Materials should be stored in secondary containments, such as an earthen dike, horse trough, or even a children’s wading pool for non-reactive materials such as detergents, oil, grease, and paints. Small amounts of material may be secondarily contained in “bus boy” trays or concrete mixing trays.
- Do not store chemicals, drums, or bagged materials directly on the ground. Place these items on a pallet and, when possible, within secondary containment.
- If drums must be kept uncovered, store them at a slight angle to reduce ponding of rainwater on the lids to reduce corrosion. Domed plastic covers are inexpensive and snap to the top of drums, preventing water from collecting.
- Liquids, petroleum products, and substances listed in 40 CFR Parts 110, 117, or 302 shall be stored in approved containers and drums and shall not be overfilled. Containers and drums shall be stored in temporary secondary containment facilities.
- Temporary secondary containment facilities shall provide for a spill containment volume able to contain 10% of the total enclosed container volume of all containers, or 110% of the capacity of the largest container within its boundary, whichever is greater.
- Secondary containment facilities shall be impervious to the materials stored therein for a minimum contact time of 72 hours.
- Sufficient separation should be provided between stored containers to allow for spill cleanup and emergency response access.
- During the wet weather season (Oct 1 – April 30), each secondary containment facility shall be covered during non-working days, prior to and during rain events.
- Keep material storage areas clean, organized and equipped with an ample supply of appropriate spill clean-up material (spill kit).
- The spill kit should include, at a minimum:

- 1-Water Resistant Nylon Bag
- 3-Oil Absorbent Socks 3"x 4'
- 2-Oil Absorbent Socks 3"x 10'
- 12-Oil Absorbent Pads 17"x19"
- 1-Pair Splash Resistant Goggles
- 3-Pair Nitrile Gloves
- 10-Disposable Bags with Ties
- Instructions

Maintenance Standards

- Secondary containment facilities shall be maintained free of accumulated rainwater and spills. In the event of spills or leaks, accumulated rainwater and spills shall be collected and placed into drums. These liquids shall be handled as hazardous waste unless testing determines them to be non-hazardous.
- Re-stock spill kit materials as needed.

BMP C160: Certified Erosion and Sediment Control Lead

Purpose

The project proponent designates at least one person as the responsible representative in charge of erosion and sediment control (ESC), and water quality protection. The designated person shall be responsible for ensuring compliance with all local, state, and federal erosion and sediment control and water quality requirements. Construction sites one acre or larger that discharge to waters of the State must designate a Certified Erosion and Sediment Control Lead (CESCL) as the responsible representative.

Conditions of Use

A CESCL shall be made available on projects one acre or larger that discharge stormwater to surface waters of the state. Sites less than one acre may have a person without CESCL certification conduct inspections.

The CESCL shall:

- Have a current certificate proving attendance in an erosion and sediment control training course that meets the minimum ESC training and certification requirements established by Ecology.

Ecology has provided the minimum requirements for CESCL course training, as well as a list of ESC training and certification providers at:

<https://ecology.wa.gov/Regulations-Permits/Permits-certifications/Certified-erosion-sediment-control>

OR

- Be a Certified Professional in Erosion and Sediment Control (CPESC). For additional information go to:

<http://www.envirocertintl.org/cpesc/>

Specifications

- CESCL certification shall remain valid for three years.
- The CESCL shall have authority to act on behalf of the contractor or project proponent and shall be available, or on-call, 24 hours per day throughout the period of construction.
- The Construction SWPPP shall include the name, telephone number, fax number, and address of the designated CESCL. See [II-2 Construction Stormwater Pollution Prevention Plans \(Construction SWPPPs\)](#).
- A CESCL may provide inspection and compliance services for multiple construction projects in the same geographic region, but must be on site whenever earthwork activities are

occurring that could generate release of turbid water.

- Duties and responsibilities of the CESCL shall include, but are not limited to the following:
 - Maintaining a permit file on site at all times which includes the Construction SWPPP and any associated permits and plans.
 - Directing BMP installation, inspection, maintenance, modification, and removal.
 - Updating all project drawings and the Construction SWPPP with changes made.
 - Completing any sampling requirements including reporting results using electronic Discharge Monitoring Reports (WebDMR).
 - Facilitate, participate in, and take corrective actions resulting from inspections performed by outside agencies or the owner.
 - Keeping daily logs, and inspection reports. Inspection reports should include:
 - Inspection date/time.
 - Weather information; general conditions during inspection and approximate amount of precipitation since the last inspection.
 - Visual monitoring results, including a description of discharged stormwater. The presence of suspended sediment, turbid water, discoloration, and oil sheen shall be noted, as applicable.
 - Any water quality monitoring performed during inspection.
 - General comments and notes, including a brief description of any BMP repairs, maintenance or installations made as a result of the inspection.
 - A summary or list of all BMPs implemented, including observations of all erosion/sediment control structures or practices. The following shall be noted:
 1. Locations of BMPs inspected.
 2. Locations of BMPs that need maintenance.
 3. Locations of BMPs that failed to operate as designed or intended.
 4. Locations of where additional or different BMPs are required.

BMP C209: Outlet Protection

Purpose

Outlet protection prevents scour at conveyance outlets and minimizes the potential for downstream erosion by reducing the velocity of concentrated stormwater flows.

Conditions of Use

Use outlet protection at the outlets of all ponds, pipes, ditches, or other conveyances that discharge to a natural or manmade drainage feature such as a stream, wetland, lake, or ditch.

Design and Installation Specifications

- The receiving channel at the outlet of a pipe shall be protected from erosion by lining a minimum of 6 feet downstream and extending up the channel sides a minimum of 1-foot above the maximum tailwater elevation, or 1-foot above the crown, whichever is higher. For pipes larger than 18 inches in diameter, the outlet protection lining of the channel shall be four times the diameter of the outlet pipe.
- Standard wingwalls, tapered outlets, and paved channels should also be considered when appropriate for permanent culvert outlet protection ([WSDOT, 2015](#)).
- [BMP C122: Nets and Blankets](#) or [BMP C202: Riprap Channel Lining](#) provide suitable options for lining materials.
- With low flows, [BMP C201: Grass-Lined Channels](#) can be an effective alternative for lining material.
- The following guidelines shall be used for outlet protection with riprap:
 - If the discharge velocity at the outlet is less than 5 fps, use 2-inch to 8-inch riprap. Minimum thickness is 1-foot.
 - For 5 to 10 fps discharge velocity at the outlet, use 24-inch to 48-inch riprap. Minimum

thickness is 2 feet.

- For outlets at the base of steep slope pipes (pipe slope greater than 10 percent), use an engineered energy dissipator.
- Filter fabric or erosion control blankets should always be used under riprap to prevent scour and channel erosion. See [BMP C122: Nets and Blankets](#).
- Bank stabilization, bioengineering, and habitat features may be required for disturbed areas. This work may require a Hydraulic Project Approval (HPA) from the Washington State Department of Fish and Wildlife. See [I-2.11 Hydraulic Project Approvals](#).

Maintenance Standards

- Inspect and repair as needed.
- Add rock as needed to maintain the intended function.
- Clean energy dissipator if sediment builds up.

BMP C220: Inlet Protection

Purpose

Inlet protection prevents coarse sediment from entering drainage systems prior to permanent stabilization of the disturbed area.

Conditions of Use

Use inlet protection at inlets that are operational before permanent stabilization of the disturbed areas that contribute runoff to the inlet. Provide protection for all storm drain inlets downslope and within 500 feet of a disturbed or construction area, unless those inlets are preceded by a sediment trapping BMP.

Also consider inlet protection for lawn and yard drains on new home construction. These small and numerous drains coupled with lack of gutters can add significant amounts of sediment into the roof drain system. If possible, delay installing lawn and yard drains until just before landscaping, or cap these drains to prevent sediment from entering the system until completion of landscaping. Provide 18-inches of sod around each finished lawn and yard drain.

[Table II-3.10: Storm Drain Inlet Protection](#) lists several options for inlet protection. All of the methods for inlet protection tend to plug and require a high frequency of maintenance. Limit contributing drainage areas for an individual inlet to one acre or less. If possible, provide emergency overflows with additional end-of-pipe treatment where stormwater ponding would cause a hazard.

Table II-3.10: Storm Drain Inlet Protection

Type of Inlet Protection	Emergency Overflow	Applicable for Paved/ Earthen Surfaces	Conditions of Use
Drop Inlet Protection			
Excavated drop inlet protection	Yes, temporary flooding may occur	Earthen	Applicable for heavy flows. Easy to maintain. Large area requirement: 30'x30'/acre
Block and gravel drop inlet protection	Yes	Paved or Earthen	Applicable for heavy concentrated flows. Will not pond.
Gravel and wire drop inlet protection	No	Paved or Earthen	Applicable for heavy concentrated flows. Will pond. Can withstand traffic.
Catch basin filters	Yes	Paved or Earthen	Frequent maintenance required.
Curb Inlet Protection			
Curb inlet protection with wooden weir	Small capacity overflow	Paved	Used for sturdy, more compact installation.
Block and gravel curb inlet protection	Yes	Paved	Sturdy, but limited filtration.
Culvert Inlet Protection			
Culvert inlet sediment trap	N/A	N/A	18 month expected life.

Design and Installation Specifications

Excavated Drop Inlet Protection

Excavated drop inlet protection consists of an excavated impoundment around the storm drain inlet. Sediment settles out of the stormwater prior to entering the storm drain. Design and installation specifications for excavated drop inlet protection include:

- Provide a depth of 1-2 ft as measured from the crest of the inlet structure.
- Slope sides of excavation should be no steeper than 2H:1V.
- Minimum volume of excavation is 35 cubic yards.
- Shape the excavation to fit the site, with the longest dimension oriented toward the longest inflow area.
- Install provisions for draining to prevent standing water.
- Clear the area of all debris.

- Grade the approach to the inlet uniformly.
- Drill weep holes into the side of the inlet.
- Protect weep holes with screen wire and washed aggregate.
- Seal weep holes when removing structure and stabilizing area.
- Build a temporary dike, if necessary, to the down slope side of the structure to prevent bypass flow.

Block and Gravel Filter

A block and gravel filter is a barrier formed around the inlet with standard concrete blocks and gravel. See [Figure II-3.17: Block and Gravel Filter](#). Design and installation specifications for block gravel filters include:

- Provide a height of 1 to 2 feet above the inlet.
- Recess the first row of blocks 2-inches into the ground for stability.
- Support subsequent courses by placing a pressure treated wood 2x4 through the block opening.
- Do not use mortar.
- Lay some blocks in the bottom row on their side to allow for dewatering the pool.
- Place hardware cloth or comparable wire mesh with ½-inch openings over all block openings.
- Place gravel to just below the top of blocks on slopes of 2H:1V or flatter.
- An alternative design is a gravel berm surrounding the inlet, as follows:
 - Provide a slope of 3H:1V on the upstream side of the berm.
 - Provide a slope of 2H:1V on the downstream side of the berm.
 - Provide a 1-foot wide level stone area between the gravel berm and the inlet.
 - Use stones 3 inches in diameter or larger on the upstream slope of the berm.
 - Use gravel ½- to ¾-inch at a minimum thickness of 1-foot on the downstream slope of the berm.

Figure II-3.17: Block and Gravel Filter

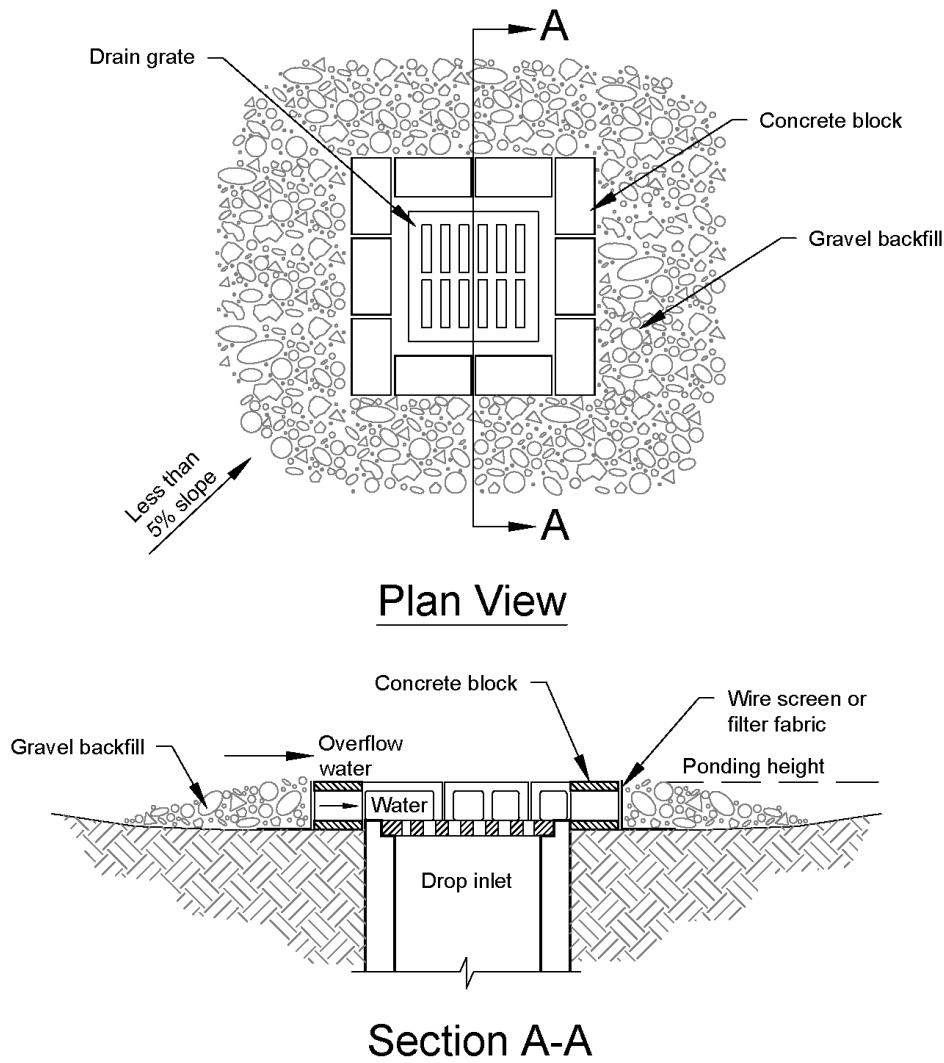

Notes:

1. Drop inlet sediment barriers are to be used for small, nearly level drainage areas. (less than 5%)
2. Excavate a basin of sufficient size adjacent to the drop inlet.
3. The top of the structure (ponding height) must be well below the ground elevation downslope to prevent runoff from bypassing the inlet. A temporary dike may be necessary on the downslope side of the structure.

NOT TO SCALE



Block and Gravel Filter

Revised June 2016

Please see <http://www.ecy.wa.gov/copyright.html> for copyright notice including permissions, limitation of liability, and disclaimer.

Gravel and Wire Mesh Filter

Gravel and wire mesh filters are gravel barriers placed over the top of the inlet. This method does not provide an overflow. Design and installation specifications for gravel and wire mesh filters include:

- Use a hardware cloth or comparable wire mesh with ½-inch openings.
 - Place wire mesh over the drop inlet so that the wire extends a minimum of 1-foot beyond each side of the inlet structure.
 - Overlap the strips if more than one strip of mesh is necessary.
- Place coarse aggregate over the wire mesh.
 - Provide at least a 12-inch depth of aggregate over the entire inlet opening and extend at least 18-inches on all sides.

Catch Basin Filters

Catch basin filters are designed by manufacturers for construction sites. The limited sediment storage capacity increases the amount of inspection and maintenance required, which may be daily for heavy sediment loads. To reduce maintenance requirements, combine a catch basin filter with another type of inlet protection. This type of inlet protection provides flow bypass without overflow and therefore may be a better method for inlets located along active rights-of-way. Design and installation specifications for catch basin filters include:

- Provides 5 cubic feet of storage.
- Requires dewatering provisions.
- Provides a high-flow bypass that will not clog under normal use at a construction site.
- Insert the catch basin filter in the catch basin just below the grating.

Curb Inlet Protection with Wooden Weir

Curb inlet protection with wooden weir is an option that consists of a barrier formed around a curb inlet with a wooden frame and gravel. Design and installation specifications for curb inlet protection with wooden weirs include:

- Use wire mesh with ½-inch openings.
- Use extra strength filter cloth.
- Construct a frame.
- Attach the wire and filter fabric to the frame.
- Pile coarse washed aggregate against the wire and fabric.
- Place weight on the frame anchors.

Block and Gravel Curb Inlet Protection

Block and gravel curb inlet protection is a barrier formed around a curb inlet with concrete blocks and gravel. See [Figure II-3.18: Block and Gravel Curb Inlet Protection](#). Design and installation specifications for block and gravel curb inlet protection include:

- Use wire mesh with ½-inch openings.
- Place two concrete blocks on their sides abutting the curb at either side of the inlet opening. These are spacer blocks.
- Place a 2x4 stud through the outer holes of each spacer block to align the front blocks.
- Place blocks on their sides across the front of the inlet and abutting the spacer blocks.
- Place wire mesh over the outside vertical face.
- Pile coarse aggregate against the wire to the top of the barrier.

Figure II-3.18: Block and Gravel Curb Inlet Protection

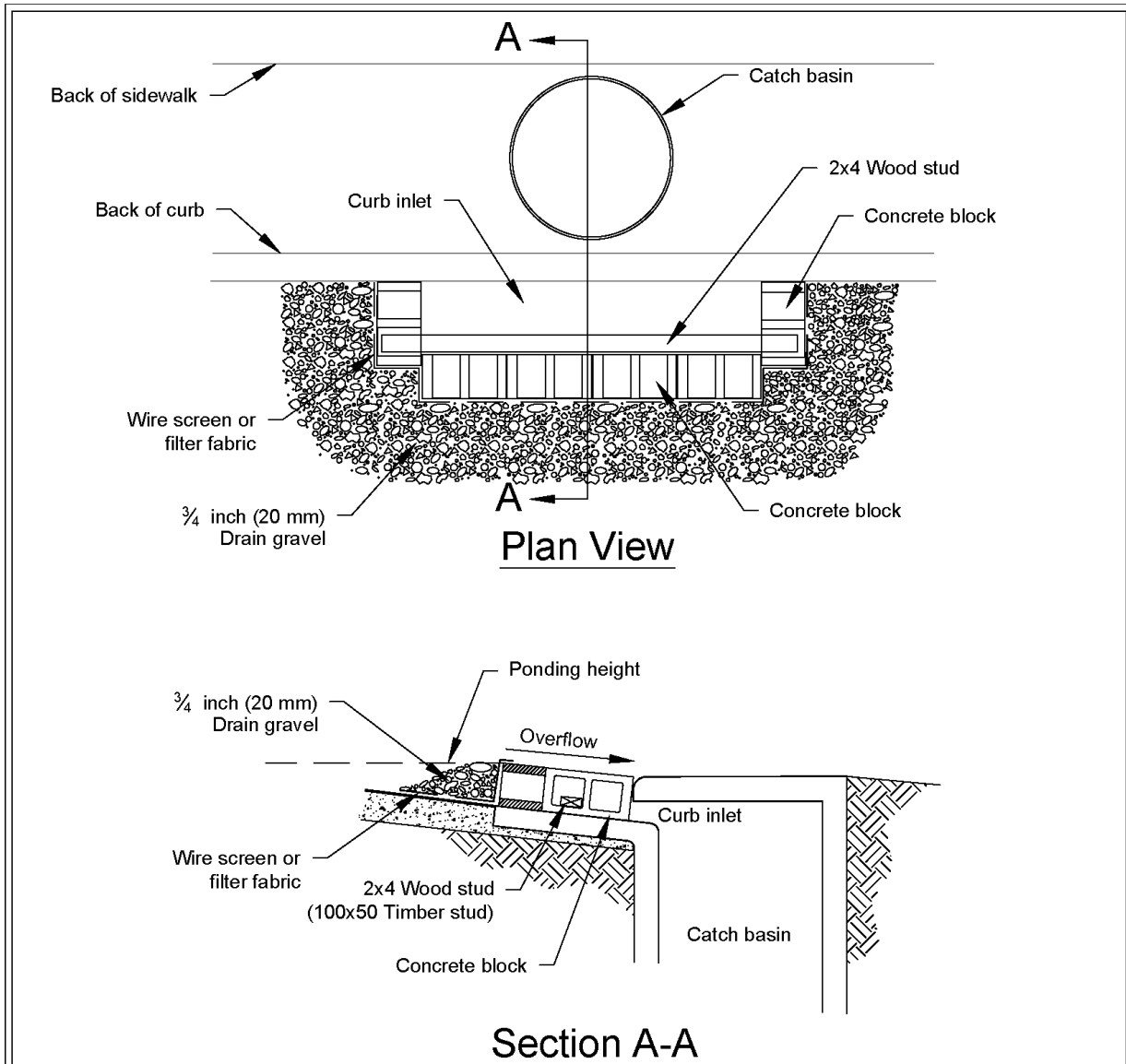

Notes:

1. Use block and gravel type sediment barrier when curb inlet is located in gently sloping street segment, where water can pond and allow sediment to separate from runoff.
2. Barrier shall allow for overflow from severe storm event.
3. Inspect barriers and remove sediment after each storm event. Sediment and gravel must be removed from the traveled way immediately.

NOT TO SCALE



Block and Gravel Curb Inlet Protection

Revised June 2016

Please see <http://www.ecy.wa.gov/copyright.html> for copyright notice including permissions, limitation of liability, and disclaimer.

Curb and Gutter Sediment Barrier

Curb and gutter sediment barrier is a sandbag or rock berm (riprap and aggregate) 3 feet high and 3 feet wide in a horseshoe shape. See [Figure II-3.19: Curb and Gutter Barrier](#). Design and installation specifications for curb and gutter sediment barrier include:

- Construct a horseshoe shaped berm, faced with coarse aggregate if using riprap, 3 feet high and 3 feet wide, at least 2 feet from the inlet.
- Construct a horseshoe shaped sedimentation trap on the upstream side of the berm. Size the trap to sediment trap standards for protecting a culvert inlet.

Figure II-3.19: Curb and Gutter Barrier

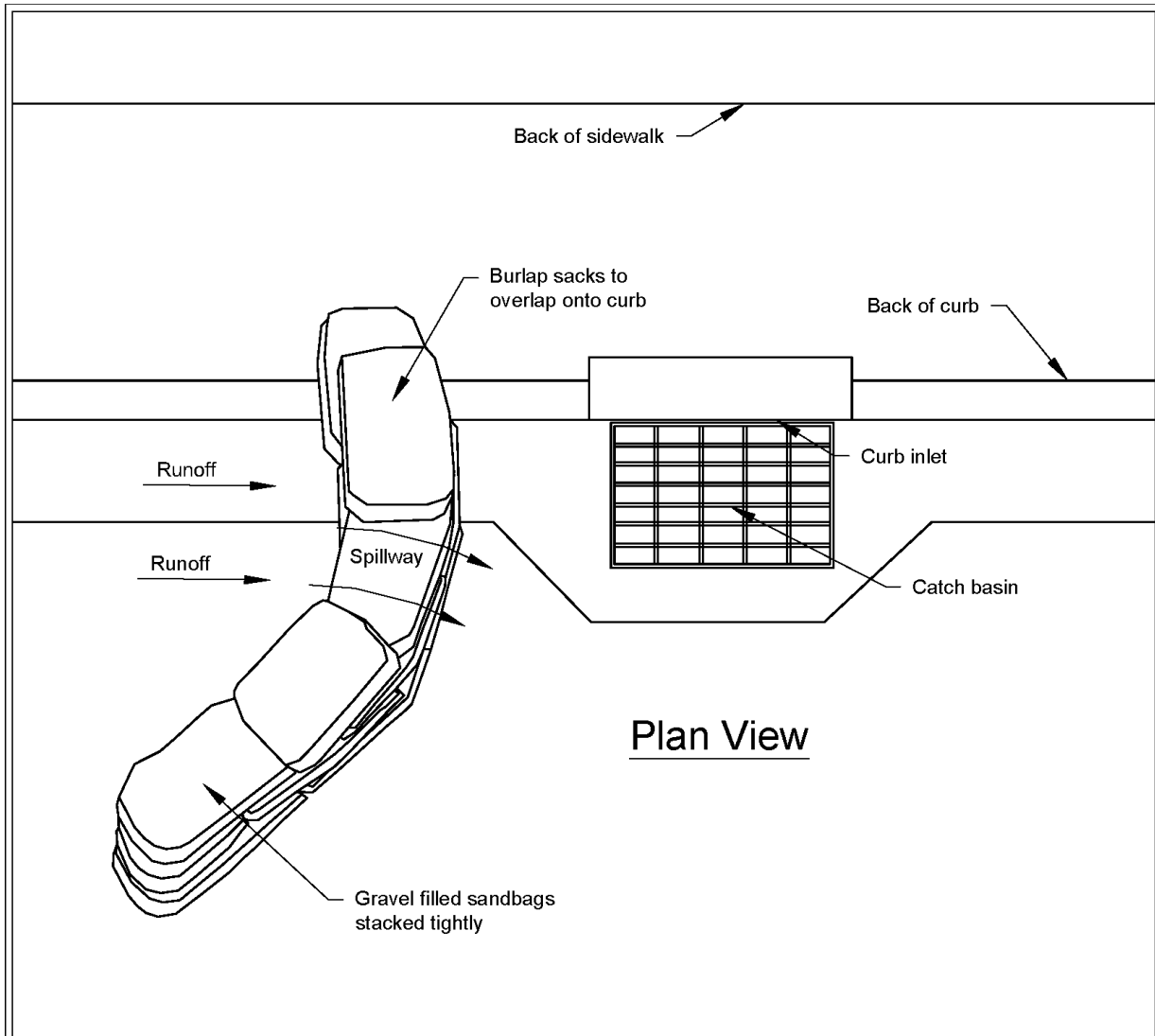

Notes:

1. Place curb type sediment barriers on gently sloping street segments, where water can pond and allow sediment to separate from runoff.
2. Sandbags of either burlap or woven 'geotextile' fabric, are filled with gravel, layered and packed tightly.
3. Leave a one sandbag gap in the top row to provide a spillway for overflow.
4. Inspect barriers and remove sediment after each storm event. Sediment and gravel must be removed from the traveled way immediately.

NOT TO SCALE



Curb and Gutter Barrier

Revised June 2016

Please see <http://www.ecy.wa.gov/copyright.html> for copyright notice including permissions, limitation of liability, and disclaimer.

Maintenance Standards

- Inspect all forms of inlet protection frequently, especially after storm events. Clean and replace clogged catch basin filters. For rock and gravel filters, pull away the rocks from the inlet and clean or replace. An alternative approach would be to use the clogged rock as fill and put fresh rock around the inlet.
- Do not wash sediment into storm drains while cleaning. Spread all excavated material evenly over the surrounding land area or stockpile and stabilize as appropriate.

Approved as Functionally Equivalent

Ecology has approved products as able to meet the requirements of this BMP. The products did not pass through the Technology Assessment Protocol – Ecology (TAPE) process. Local jurisdictions may choose not to accept these products, or may require additional testing prior to consideration for local use. Products that Ecology has approved as functionally equivalent are available for review on Ecology's website at:

<https://ecology.wa.gov/Regulations-Permits/Guidance-technical-assistance/Stormwater-permittee-guidance-resources/Emerging-stormwater-treatment-technologies>

BMP C233: Silt Fence

Purpose

Silt fence reduces the transport of coarse sediment from a construction site by providing a temporary physical barrier to sediment and reducing the runoff velocities of overland flow.

Conditions of Use

Silt fence may be used downslope of all disturbed areas.

- Silt fence shall prevent sediment carried by runoff from going beneath, through, or over the top of the silt fence, but shall allow the water to pass through the fence.
- Silt fence is not intended to treat concentrated flows, nor is it intended to treat substantial amounts of overland flow. Convey any concentrated flows through the drainage system to a sediment trapping BMP.
- Do not construct silt fences in streams or use in V-shaped ditches. Silt fences do not provide an adequate method of silt control for anything deeper than sheet or overland flow.

Figure II-3.22: Silt Fence

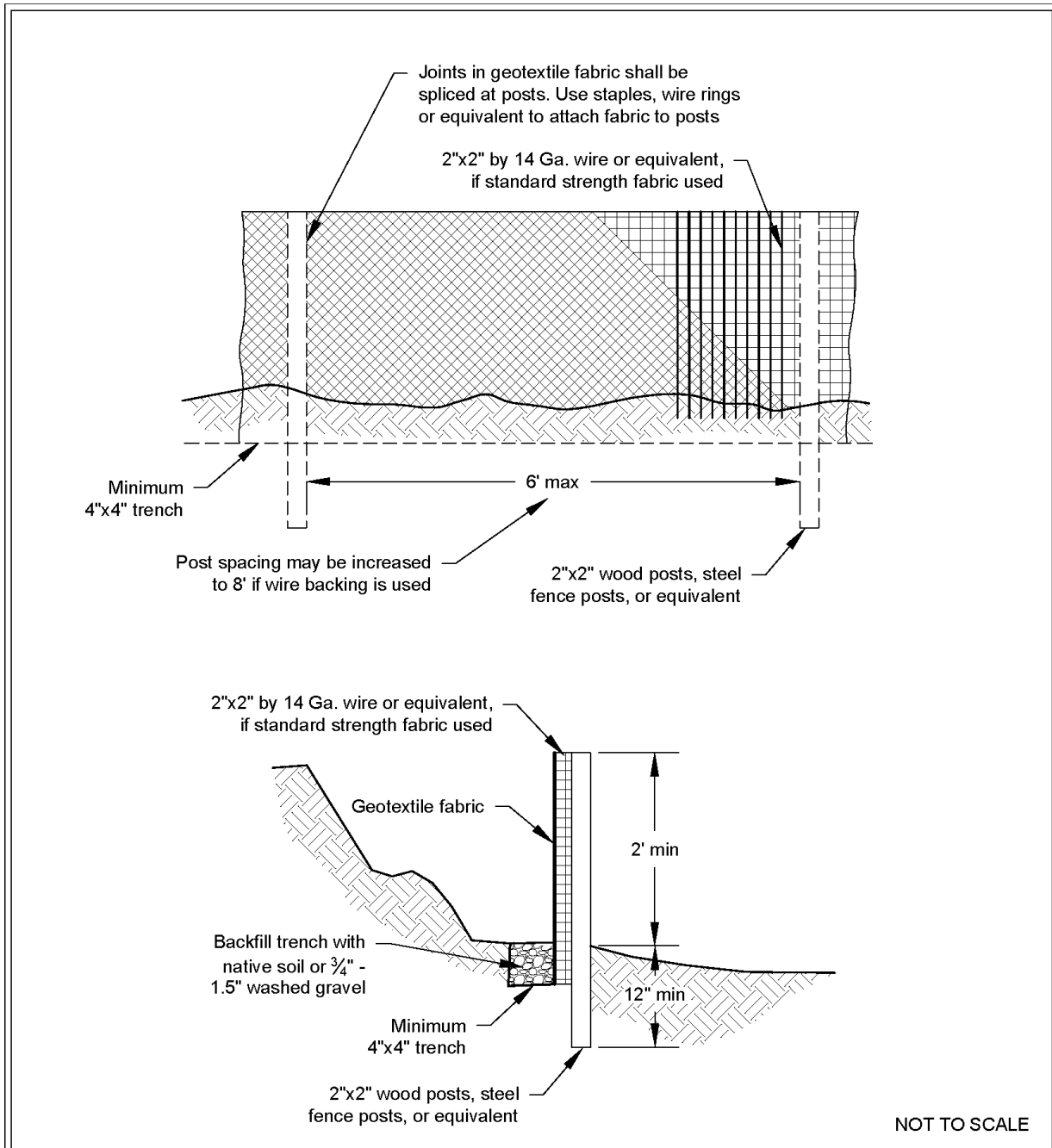

Silt Fence

Revised July 2017

Please see <http://www.ecy.wa.gov/copyright.html> for copyright notice including permissions, limitation of liability, and disclaimer.

Design and Installation Specifications

- Use in combination with other construction stormwater BMPs.
- Maximum slope steepness (perpendicular to the silt fence line) 1H:1V.
- Maximum sheet or overland flow path length to the silt fence of 100 feet.
- Do not allow flows greater than 0.5 cfs.
- Use geotextile fabric that meets the following standards. All geotextile properties listed below are minimum average roll values (i.e., the test result for any sampled roll in a lot shall meet or exceed the values shown in [Table II-3.11: Geotextile Fabric Standards for Silt Fence](#)):

Table II-3.11: Geotextile Fabric Standards for Silt Fence

Geotextile Property	Minimum Average Roll Value
Polymeric Mesh AOS (ASTM D4751)	0.60 mm maximum for slit film woven (#30 sieve). 0.30 mm maximum for all other geotextile types (#50 sieve). 0.15 mm minimum for all fabric types (#100 sieve).
Water Permittivity (ASTM D4491)	0.02 sec ⁻¹ minimum
Grab Tensile Strength (ASTM D4632)	180 lbs. Minimum for extra strength fabric. 100 lbs minimum for standard strength fabric.
Grab Tensile Strength (ASTM D4632)	30% maximum
Ultraviolet Resistance (ASTM D4355)	70% minimum

- Support standard strength geotextiles with wire mesh, chicken wire, 2-inch x 2-inch wire, safety fence, or jute mesh to increase the strength of the geotextile. Silt fence materials are available that have synthetic mesh backing attached.
- Silt fence material shall contain ultraviolet ray inhibitors and stabilizers to provide a minimum of six months of expected usable construction life at a temperature range of 0°F to 120°F.
- One-hundred percent biodegradable silt fence is available that is strong, long lasting, and can be left in place after the project is completed, if permitted by the local jurisdiction.
- Refer to [Figure II-3.22: Silt Fence](#) for standard silt fence details. Include the following Standard Notes for silt fence on construction plans and specifications:
 1. The Contractor shall install and maintain temporary silt fences at the locations shown in the Plans.
 2. Construct silt fences in areas of clearing, grading, or drainage prior to starting those activities.

3. The silt fence shall have a 2-foot min. and a 2½-foot max. height above the original ground surface.
4. The geotextile fabric shall be sewn together at the point of manufacture to form fabric lengths as required. Locate all sewn seams at support posts. Alternatively, two sections of silt fence can be overlapped, provided that the overlap is long enough and that the adjacent silt fence sections are close enough together to prevent silt laden water from escaping through the fence at the overlap.
5. Attach the geotextile fabric on the up-slope side of the posts and secure with staples, wire, or in accordance with the manufacturer's recommendations. Attach the geotextile fabric to the posts in a manner that reduces the potential for tearing.
6. Support the geotextile fabric with wire or plastic mesh, dependent on the properties of the geotextile selected for use. If wire or plastic mesh is used, fasten the mesh securely to the up-slope side of the posts with the geotextile fabric up-slope of the mesh.
7. Mesh support, if used, shall consist of steel wire with a maximum mesh spacing of 2-inches, or a prefabricated polymeric mesh. The strength of the wire or polymeric mesh shall be equivalent to or greater than 180 lbs. grab tensile strength. The polymeric mesh must be as resistant to the same level of ultraviolet radiation as the geotextile fabric it supports.
8. Bury the bottom of the geotextile fabric 4-inches min. below the ground surface. Backfill and tamp soil in place over the buried portion of the geotextile fabric, so that no flow can pass beneath the silt fence and scouring cannot occur. When wire or polymeric back-up support mesh is used, the wire or polymeric mesh shall extend into the ground 3-inches min.
9. Drive or place the silt fence posts into the ground 18-inches min. A 12-inch min. depth is allowed if topsoil or other soft subgrade soil is not present and 18-inches cannot be reached. Increase fence post min. depths by 6 inches if the fence is located on slopes of 3H:1V or steeper and the slope is perpendicular to the fence. If required post depths cannot be obtained, the posts shall be adequately secured by bracing or guying to prevent overturning of the fence due to sediment loading.
10. Use wood, steel or equivalent posts. The spacing of the support posts shall be a maximum of 6-feet. Posts shall consist of either:
 - Wood with minimum dimensions of 2 inches by 2 inches by 3 feet. Wood shall be free of defects such as knots, splits, or gouges.
 - No. 6 steel rebar or larger.
 - ASTM A 120 steel pipe with a minimum diameter of 1-inch.
 - U, T, L, or C shape steel posts with a minimum weight of 1.35 lbs./ft.
 - Other steel posts having equivalent strength and bending resistance to the post sizes listed above.
11. Locate silt fences on contour as much as possible, except at the ends of the fence,

where the fence shall be turned uphill such that the silt fence captures the runoff water and prevents water from flowing around the end of the fence.

12. If the fence must cross contours, with the exception of the ends of the fence, place check dams perpendicular to the back of the fence to minimize concentrated flow and erosion. The slope of the fence line where contours must be crossed shall not be steeper than 3H:1V.
 - Check dams shall be approximately 1-foot deep at the back of the fence. Check dams shall be continued perpendicular to the fence at the same elevation until the top of the check dam intercepts the ground surface behind the fence.
 - Check dams shall consist of crushed surfacing base course, gravel backfill for walls, or shoulder ballast. Check dams shall be located every 10 feet along the fence where the fence must cross contours.
- Refer to [Figure II-3.23: Silt Fence Installation by Slicing Method](#) for slicing method details. The following are specifications for silt fence installation using the slicing method:
 1. The base of both end posts must be at least 2- to 4-inches above the top of the geotextile fabric on the middle posts for ditch checks to drain properly. Use a hand level or string level, if necessary, to mark base points before installation.
 2. Install posts 3- to 4-feet apart in critical retention areas and 6- to 7-feet apart in standard applications.
 3. Install posts 24-inches deep on the downstream side of the silt fence, and as close as possible to the geotextile fabric, enabling posts to support the geotextile fabric from upstream water pressure.
 4. Install posts with the nipples facing away from the geotextile fabric.
 5. Attach the geotextile fabric to each post with three ties, all spaced within the top 8-inches of the fabric. Attach each tie diagonally 45 degrees through the fabric, with each puncture at least 1-inch vertically apart. Each tie should be positioned to hang on a post nipple when tightening to prevent sagging.
 6. Wrap approximately 6-inches of the geotextile fabric around the end posts and secure with 3 ties.
 7. No more than 24-inches of a 36-inch geotextile fabric is allowed above ground level.
 8. Compact the soil immediately next to the geotextile fabric with the front wheel of the tractor, skid steer, or roller exerting at least 60 pounds per square inch. Compact the upstream side first and then each side twice for a total of four trips. Check and correct the silt fence installation for any deviation before compaction. Use a flat-bladed shovel to tuck the fabric deeper into the ground if necessary.

Figure II-3.23: Silt Fence Installation by Slicing Method

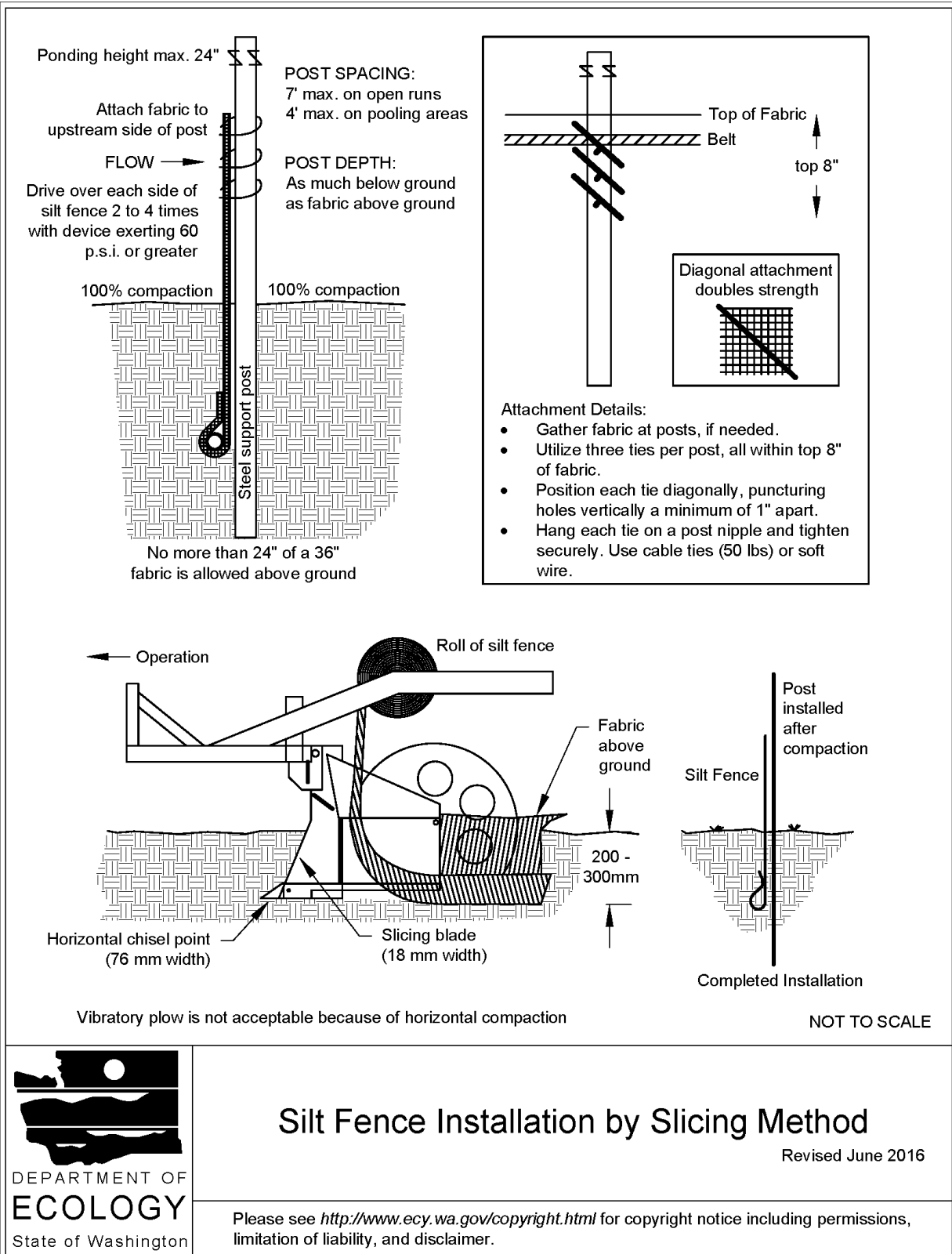

Maintenance Standards

- Repair any damage immediately.
- Intercept and convey all evident concentrated flows uphill of the silt fence to a sediment trapping BMP.
- Check the uphill side of the silt fence for signs of the fence clogging and acting as a barrier to flow and then causing channelization of flows parallel to the fence. If this occurs, replace the fence and remove the trapped sediment.
- Remove sediment deposits when the deposit reaches approximately one-third the height of the silt fence, or install a second silt fence.
- Replace geotextile fabric that has deteriorated due to ultraviolet breakdown.

BMP C241: Sediment Pond (Temporary)

Purpose

Sediment ponds are temporary ponds used during construction to remove sediment from runoff originating from disturbed areas of the project site. Sediment ponds are typically designed to remove sediment no smaller than medium silt (0.02 mm). Consequently, they usually reduce turbidity only slightly.

Conditions of Use

- Use a sediment pond where the contributing drainage area to the pond is 3 acres or more. Ponds must be used in conjunction with other Construction Stormwater BMPs to reduce the amount of sediment flowing into the pond.
- Do not install sediment ponds on sites where failure of the BMP would result in loss of life, damage to homes or buildings, or interruption of use or service of public roads or utilities. Also, sediment ponds are attractive to children and can be dangerous. Compliance with local ordinances regarding health and safety must be addressed. If fencing of the pond is required, show the type of fence and its location on the drawings in the Construction SWPPP.
- Sediment ponds that can impound 10 acre-ft (435,600 cu-ft, or 3.26 million gallons) or more, or have an embankment of more than 6 feet, are subject to the Washington Dam Safety Regulations ([Chapter 173-175 WAC](#)). See [BMP D.1: Detention Ponds](#) for more information regarding dam safety considerations for detention ponds.
- Projects that are constructing permanent Flow Control BMPs or Runoff Treatment BMPs that use ponding for treatment may use the rough-graded or final-graded permanent BMP footprint for the temporary sediment pond. When permanent BMP footprints are used as temporary sediment ponds, the surface area requirement of the temporary sediment pond must be met. If the surface area requirement of the sediment pond is larger than the surface area of the permanent BMP, then the sediment pond shall be enlarged beyond the permanent BMP footprint to comply with the surface area requirement.

The permanent control structure must be temporarily replaced with a control structure that only allows water to leave the temporary sediment pond from the surface or by pumping. Alternatively, the permanent control structure may be used if it is temporarily modified by plugging any outlet holes below the riser. The permanent control structure must be installed as part of the permanent BMP after the site is fully stabilized.

Design and Installation Specifications

General

- See [Figure II-3.28: Sediment Pond Plan View](#), [Figure II-3.29: Sediment Pond Cross Section](#), and [Figure II-3.30: Sediment Pond Riser Detail](#) for details.
- Use of permanent infiltration BMP footprints for temporary sediment ponds during

construction tends to clog the soils and reduce their capacity to infiltrate. If permanent infiltration BMP footprints are used, the sides and bottom of the temporary sediment pond must only be rough excavated to a minimum of 2 feet above final grade of the permanent infiltration BMP. Final grading of the permanent infiltration BMP shall occur only when all contributing drainage areas are fully stabilized. Any proposed permanent pretreatment BMP prior to the infiltration BMP should be fully constructed and used with the temporary sediment pond to help prevent clogging of the soils. See [Element 13: Protect Low Impact Development BMPs](#) for more information about protecting permanent infiltration BMPs.

- The pond shall be divided into two roughly equal volume cells by a permeable divider that will reduce turbulence while allowing movement of water between the cells. The divider shall be at least one-half the height of the riser, and at least one foot below the top of the riser. Wire-backed, 2- to 3-foot high, high strength geotextile fabric supported by treated 4"x4"s can be used as a divider. Alternatively, staked straw bales wrapped with geotextile fabric may be used. If the pond is more than 6 feet deep, a different divider design must be proposed. A riprap embankment is one acceptable method of separation for deeper ponds. Other designs that satisfy the intent of this provision are allowed as long as the divider is permeable, structurally sound, and designed to prevent erosion under and around the divider.
- The most common structural failure of sediment ponds is caused by piping. Piping refers to two phenomena: (1) water seeping through fine-grained soil, eroding the soil grain by grain and forming pipes or tunnels; and, (2) water under pressure flowing upward through a granular soil with a head of sufficient magnitude to cause soil grains to lose contact and capability for support.

The most critical construction practices to prevent piping are:

- Tight connections between the riser and outlet pipe, and other pipe connections.
- Adequate anchoring of the riser.
- Proper soil compaction of the embankment and riser footing.
- Proper construction of anti-seep devices.

Sediment Pond Geometry

To determine the sediment pond geometry, first calculate the design surface area (SA) of the pond, measured at the top of the riser pipe. Use the following equation:

$$SA = 2 \times Q_2 / 0.00096$$

or

2080 square feet per cfs of inflow

See [BMP C240: Sediment Trap](#) for more information on the above equation.

The basic geometry of the pond can now be determined using the following design criteria:

- Required surface area SA (from the equation above) at the top of the riser.
- Minimum 3.5-foot depth from the top of the riser to the bottom of the pond.

- Maximum 3H:1V interior side slopes and maximum 2H:1V exterior slopes. The interior slopes can be increased to a maximum of 2H:1V if fencing is provided at or above the maximum water surface.
- One foot of freeboard between the top of the riser and the crest of the emergency spillway.
- Flat bottom.
- Minimum 1-foot deep spillway.
- Length-to-width ratio between 3:1 and 6:1.

Sediment Pond Discharge

The outlet for the pond consists of a combination of principal and emergency spillways. These outlets must pass the peak runoff expected from the contributing drainage area for a 100-year storm. If, due to site conditions and basin geometry, a separate emergency spillway is not feasible, the principal spillway must pass the entire peak runoff expected from the 100-year storm. However, an attempt to provide a separate emergency spillway should always be made. Base the runoff calculations on the site conditions during construction. The flow through the dewatering orifice cannot be utilized when calculating the 100-year storm elevation because of its potential to become clogged; therefore, available spillway storage must begin at the principal spillway riser crest.

The principal spillway designed by the procedures described below will result in some reduction in the peak rate of runoff. However, the design will not control the discharge flow rates to the extent required to comply with [I-3.4.7 MR7: Flow Control](#). The size of the contributing basin, the expected life of the construction project, the anticipated downstream effects, and the anticipated weather conditions during construction should be considered to determine the need for additional discharge control.

Principal Spillway: Determine the required diameter for the principal spillway (riser pipe). The diameter shall be the minimum necessary to pass the peak volumetric flow rate using a 15-minute time step from a Type 1A, 10-year, 24-hour frequency storm for the developed condition. Use [Figure II-3.31: Riser Inflow Curves](#) to determine the riser diameter.

To aid in determining sediment depth, one-foot intervals shall be prominently marked on the riser.

Emergency Overflow Spillway: Size the emergency overflow spillway for the peak volumetric flow rate using a 10-minute time step from a Type 1A, 100-year, 24-hour frequency storm for the developed condition. See [BMP D.1: Detention Ponds](#) for additional guidance for Emergency Overflow Spillway design

Dewatering Orifice: Size of the dewatering orifice(s) (minimum 1-inch diameter) using a modified version of the discharge equation for a vertical orifice and a basic equation for the area of a circular orifice. Determine the required area of the orifice with the following equation:

$$A_o = \frac{A_s(2h)^{0.5}}{0.6 \times 3600T_g^{0.5}}$$

where

A_o = orifice area (square feet)

A_S = pond surface area (square feet)

h = head of water above orifice (height of riser in feet)

T = dewatering time (24 hours)

g = acceleration of gravity (32.2 feet/second²)

Convert the orifice area (in square feet) to the orifice diameter D (in inches):

$$D = 24 \times \sqrt{\frac{A_o}{\pi}} = 13.54 \times \sqrt{A_o}$$

The vertical, perforated tubing connected to the dewatering orifice must be at least 2 inches larger in diameter than the orifice to improve flow characteristics. The size and number of perforations in the tubing should be large enough so that the tubing does not restrict flow. The orifice should control the flow rate.

Figure II-3.28: Sediment Pond Plan View

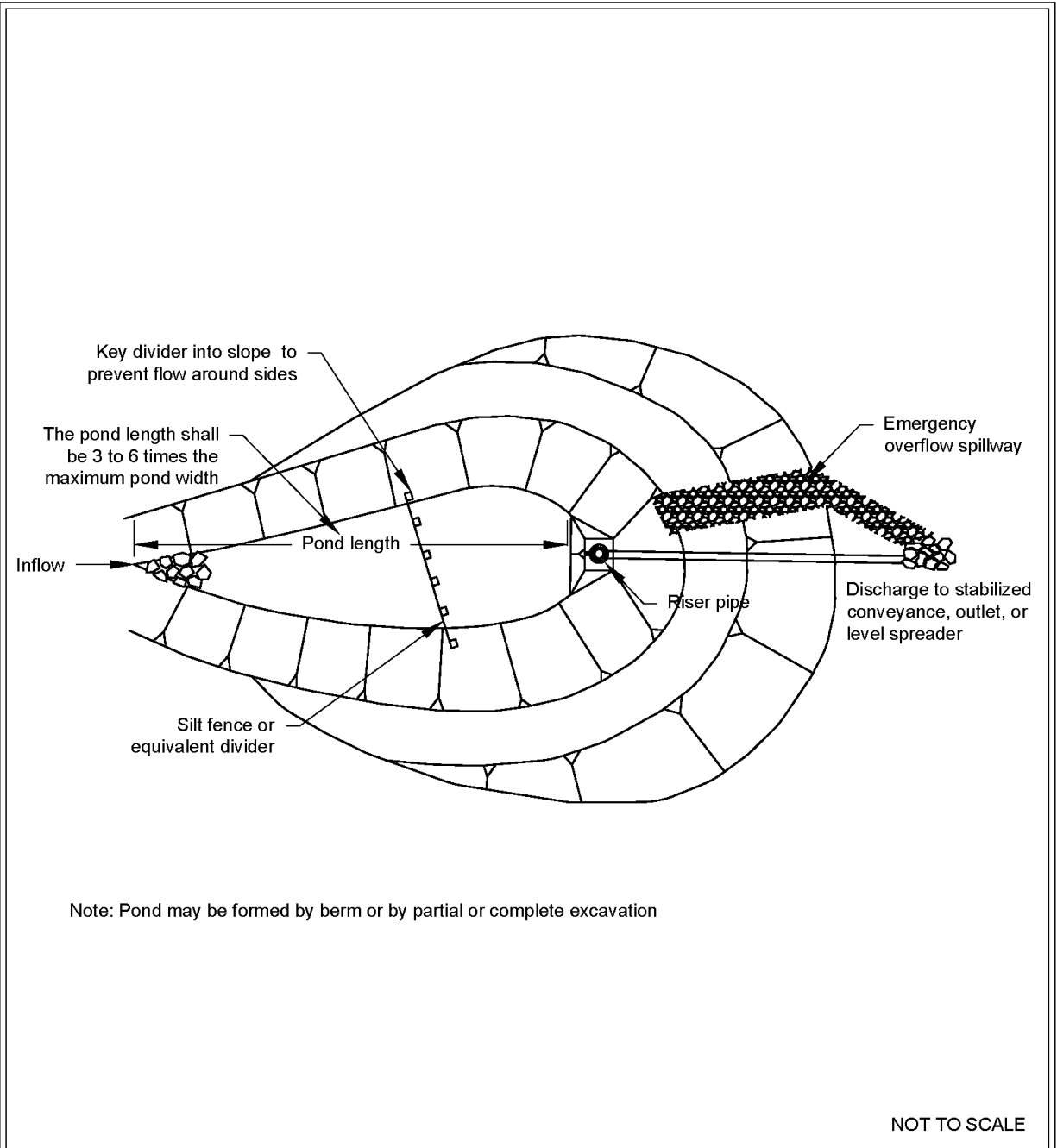

Sediment Pond Plan View

Revised June 2016

Please see <http://www.ecy.wa.gov/copyright.html> for copyright notice including permissions, limitation of liability, and disclaimer.

Figure II-3.29: Sediment Pond Cross Section

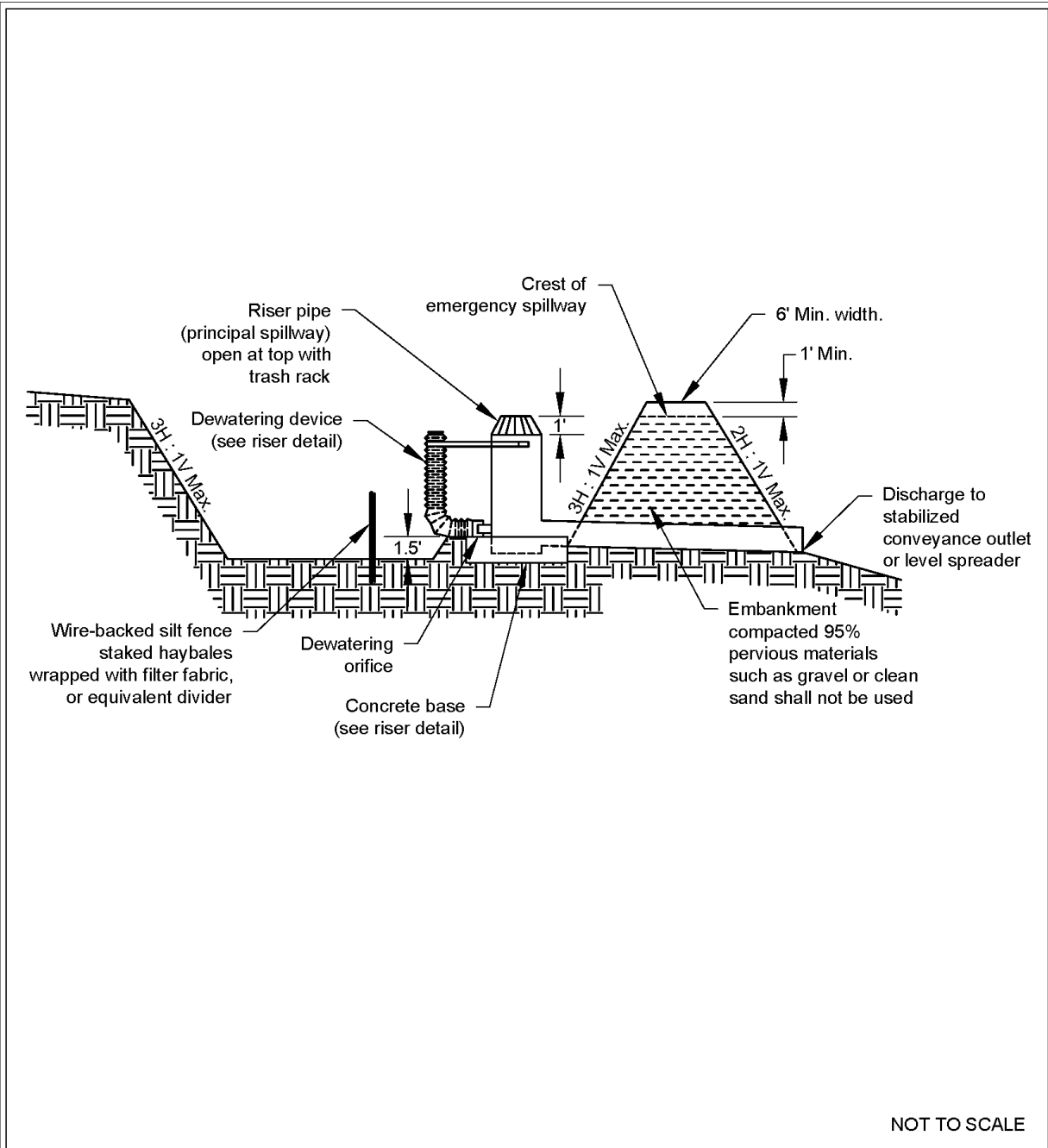

Sediment Pond Cross Section

Revised June 2016

Please see <http://www.ecy.wa.gov/copyright.html> for copyright notice including permissions, limitation of liability, and disclaimer.

Figure II-3.30: Sediment Pond Riser Detail

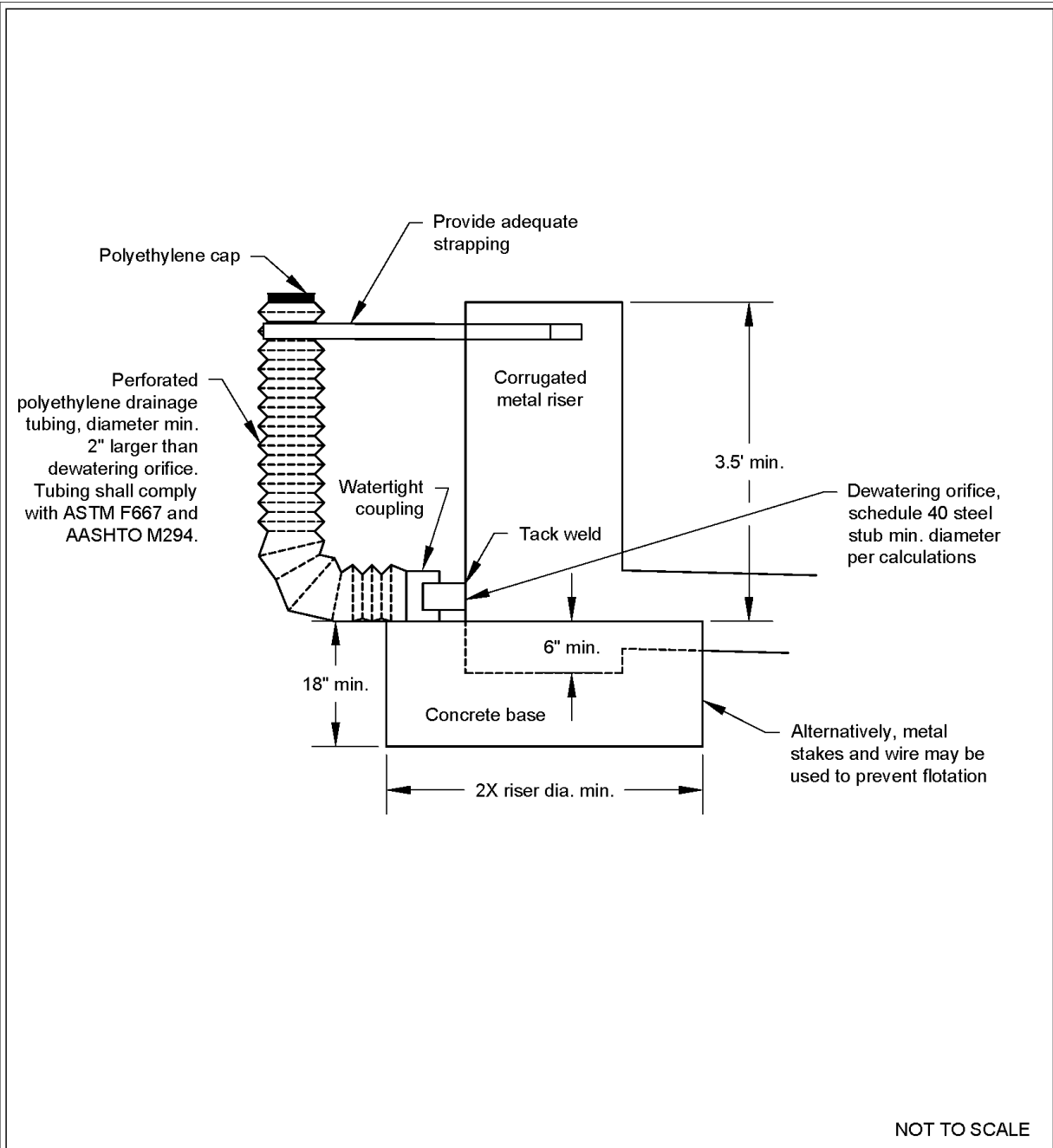

Sediment Pond Riser Detail

Revised June 2016

Please see <http://www.ecy.wa.gov/copyright.html> for copyright notice including permissions, limitation of liability, and disclaimer.

Figure II-3.31: Riser Inflow Curves

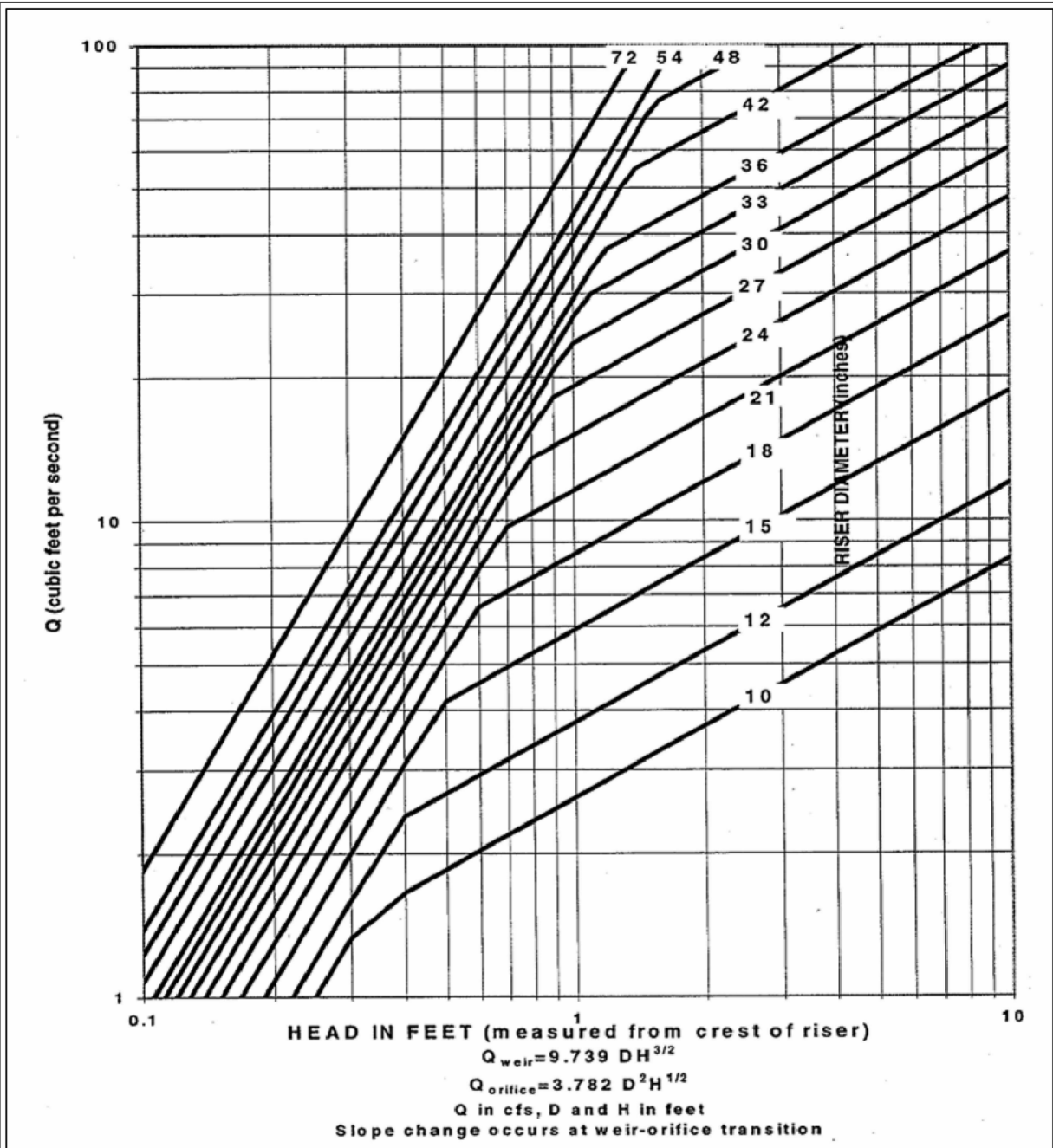

Riser Inflow Curves

Revised June 2016

Please see <http://www.ecy.wa.gov/copyright.html> for copyright notice including permissions, limitation of liability, and disclaimer.

Maintenance Standards

- Remove sediment from the pond when it reaches 1 foot in depth.
- Repair any damage to the pond embankments or slopes.