



## **Building Systems Submittal Package**

**Good Samaritan Hospital  
401 15th Ave  
Puyallup, WA 98371**

**ED Fast Track Remodel  
Fire Alarm System T.I.**

**January 26, 2024**

**Johnson Controls Fire Protection  
12781 Gateway Dr  
Tukwila, WA 98168  
Phone: 206-291-1400**

[www.JohnsonControls.com](http://www.JohnsonControls.com)

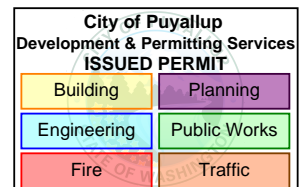



**This Page Left Blank Intentionally**



## **Table of Contents**

<b>Section I:</b>	<b>Scheduling/Installation Checklist</b>
<b>Section II:</b>	<b>Hardware Warranty</b>
<b>Section III:</b>	<b>Manufacturer's Recommendation</b>
<b>Section IV:</b>	<b>Testing Procedure for Devices</b>
<b>Section V:</b>	<b>Equipment Lists</b>
<b>Section VI:</b>	<b>Material System Data Sheets</b>



**This Page Left Blank Intentionally**



## Scheduling

Thank you for working with Johnson Controls on this project. We would like to take this opportunity to introduce you to the project team. KEVIN BARREITH is the Project Manager assigned to this project to help with generic project information. ERIC BECK is the project system specialist to assist with drawings/design questions. YVONNE THOMPSON is available for scheduling technicians.

Office: (206) 291-1400

Fax: (206) 291-1500

In an effort to assist you in your installation we require you to arrange a Pre-Construction meeting with one of our Technicians. This meeting will allow your field foreman to ask any questions they may have in regard to the installation of your system. Based on the equipment quantities and current scope of work our Technician will need no less than **30** business days to complete all necessary programming and commissioning from the time the below checklist is complete prior to any AHJ testing. Please make sure this time is allowed for in the General Construction CPM schedule as it cannot be compressed. Change orders, change of scope, etc. may require additional time allotment to field personnel.

## Installation Checklist

Johnson Controls is committed to providing the highest quality service available. As part of this service we want to ensure that the installation results in a trouble-free system. Please review the Checklist below and ensure each item is complete prior to our site visit.

A Technician will be dispatched only after the below checklist items have been completed. If these items are not completed prior to the visit by our technician, you may incur additional charges not covered by our quotation. Please feel free to contact our office if you have any questions.

- Fire Alarm Panel(s) have been mounted and all wiring (power, MAPNET, signal, door-holders, etc.) pulled into panel(s).
- All wiring pulled into panel(s) or junction boxes have been permanently marked with wire markers and can easily be identified by a Johnson Controls
- System Power is supplied and on a dedicated circuit (Do Not Energize prior to Technician visit).
- All peripheral devices have been mounted (Smoke Detectors still covered).
- All end-of-line resistors have been installed.
- All alarm initiating circuits (smoke detectors, pull stations, etc.) have been checked for shorts, opens and grounds.
- All alarm notification circuits (speakers, horns, strobes, etc.) have been checked for shorts, opens and grounds.
- All remaining wiring (door-holders, FACP 24VDC, etc.) has been checked.
- Flows, Tampers, and Pressure Switches installed, properly wired and adjusted.
- All devices are properly protected against construction dust and contamination.
- Contact us immediately if there is no digital dialer or system monitoring provisions already in place. The dialer, phone lines and service will be required for system testing.
- There are no missing parts or equipment.



## Hardware Warranty

- 1) JOHNSON CONTROLS WARRANTY STATEMENT:
  - a) JOHNSON CONTROLS WARRANTS TO THE PURCHASER OF NEW JOHNSON CONTROLS PRODUCT(S) THAT THE PRODUCTS SHALL BE FREE FROM DEFECTS IN WORKMANSHIP AND MATERIAL.
- 2) WARRANTY PERIOD:
  - a) THE WARRANTY PERIOD WILL TERMINATE IMMEDIATELY FOLLOWING THE EARLIEST OCCURRENCE OF EITHER OF THE FOLLOWING:
    - i) 18 MONTHS HAVE ELAPSED FOLLOWING SHIPMENT OF ANY SYSTEM OR SUB-SYSTEM FROM JOHNSON CONTROLS TO THE CUSTOMER, OR
    - ii) 12 MONTHS HAVE ELAPSED FOLLOWING THE FINAL CONNECTION OPERATION AND BENEFICIAL USE OF ALL OR ANY PART OF THE SYSTEM.
    - iii) AS STATED IN THE SPECIFICATIONS AND/OR CONTRACT DRAWINGS
- 3) JOHNSON CONTROLS OBLIGATION UNDER THE TERMS OF THE WARRANTY:
  - a) JOHNSON CONTROLS'S SOLE RESPONSIBILITY SHALL BE TO REPAIR, ADJUST OR REPLACE, AT ITS OPTION, ANY JOHNSON CONTROLS PRODUCT WHICH FAILS DURING THIS PERIOD PROVIDING PURCHASER HAS PROMPTLY REPORTED SUCH FAILURE TO JOHNSON CONTROLS IN WRITING. REPLACEMENT PARTS WILL BE WARRANTED ONLY FOR THE BALANCE OF THE EQUIPMENT WARRANTY. JOHNSON CONTROLS AGREES TO CONTINUE TO HONOR ALL OF THE UNEXPIRED EXPRESSED WARRANTIES SPECIFIED ABOVE ON DEFECTIVE EQUIPMENT AFTER TRANSFER OF THE EQUIPMENT TO PURCHASER'S CUSTOMER, PROVIDED PURCHASER'S CUSTOMER ASSUMES THE PURCHASER'S OBLIGATIONS SPECIFIED BELOW.
  - b) EXCEPT FOR THE EXPRESSED WARRANTIES STATED HEREIN, JOHNSON CONTROLS DISCLAIMS ALL WARRANTIES ON PRODUCTS FURNISHED HEREUNDER, INCLUDING WITHOUT LIMITATION, ALL IMPLIED WARRANTIES OF MERCHANTABILITY AND FITNESS FOR A PARTICULAR PURPOSE, AND THE STATED WARRANTIES ARE IN LIEU OF ALL OBLIGATIONS OR LIABILITIES ON THE PART OF THE JOHNSON CONTROLS ARISING OUT OF OR IN CONNECTION WITH THE PERFORMANCE OF THE PRODUCTS. THE SELLER SHALL NOT BE LIABLE FOR ANY DIRECT, INCIDENTAL OR CONSEQUENTIAL LOSS OR DAMAGE TO THE PRUCHASER OR USER OF THIS EQUIPMENT ARISING OUT OF THE FAILURE OF THE EQUIPMENT TO OPERATE IN EXCESS OF THE PURCHASE PRICE OF SAID EQUIPMENT.
  - c) JOHNSON CONTROLS MAKES NO WARRANTY AND NO WARRANTY SHALL BE DEEMED TO EXIST, THAT PURCHASER HOLDS THE GOODS FREE OF THE CLAIM OF ANY THIRD PERSON BYWAY OF PATENT INFRINGEMENT OR THE LIKE.
- 4) PURCHASER'S OBLIGATIONS UNDER THE TERMS OF THE WARRANTY.
  - a) THIS WARRANTY IS CONTINGENT UPON THE PROPER INSTALLATION AND USE OF THE PRODUCT(S). SUCH WARRANTY SHALL NOT APPLY IF THE PRODUCT FAILURE IS THE RESULT OF ACCIDENT, UNUSUAL PHYSICAL, ELECTRICAL OR ELECTROMECHANICAL STRESS, NEGLIGENCE, MISUSE, USER PROGRAMMING ERRORS, FAILURE OF ELECTRICAL POWER, AIR CONDITIONING OR HUMIDITY CONTROL, CONSTRUCTION DUST, DAMAGING FOREIGN SUBSTANCES, TRANSPORTATION OR CAUSES OTHER THAN MANUFACTURING DEFECT. PURCHASER AGREES TO PROVIDE FULL AND FREE ACCESS TO AUTHORIZED JOHNSON CONTROLS EMPLOYEES.
  - b) WARRANTY SERVICE HOURS
    - i) SERVICES PROVIDED UNDER THIS WARRANTY WILL BE PERFORMED DURING THE HOURS OF 8:00A.M. TO 5:00P.M., MONDAY THROUGH FRIDAY, EXCLUDING LOCALLY OBSERVED JOHNSON CONTROLS HOLIDAYS. OFF HOURS RESPONSE IS AVAILABLE AS AN EXTRA COST SERVICE OPTION.
- 5) WARRANTY EXCLUSIONS:
  - a) LABOR, TRAVEL, AND MILEAGE FOR:
    - i) SERVICE OUTSIDE OF JOHNSON CONTROLS NORMAL BUSINESS HOURS.
    - ii) PROGRAMMING AND/OR LABEL CHANGES.
    - iii) FAILURE DUE TO EXTERNAL CAUSES (LIGHTNING SURGES, CONSTRUCTION DUST, ETC.) OTHER THAN MANUFACTURING DEFECT.
  - b) ELECTRICAL WORK EXTERNAL TO THE EQUIPMENT SUPPLIED BY JOHNSON CONTROLS OR MAINTENANCE OF ACCESSORIES, ALTERATIONS, ATTACHMENTS OR OTHER DEVICES NOT FURNISHED BY JOHNSON CONTROLS.
  - c) BATTERIES.
  - d) COVERAGE OF EQUIPMENT CLASSSED AS A WATER FLOW MONITORING/CONTROL DEVICES INSTALLED IN OR ON WATER PIPING.



## Manufacturer's Recommendation

- 1) CONTRACTOR IS EXPECTED TO PULL AND TERMINATE ALL CONDUCTORS AND INSTALL ALL DEVICES FOR A COMPLETE AND OPERATING SYSTEM.
- 2) WHERE FAN SHUTDOWN, ELEVATOR RECALL OR SPECIAL AUXILIARY FUNCTIONS ARE REQUIRED, CONTRACTOR IS TO VERIFY WIRING REQUIREMENTS WITH THE JOHNSON CONTROLS FACTORY TECHNICIAN ASSIGNED TO THE PROJECT (IN MANY CASES, SPECIAL WIRING WILL NOT BE SHOWN ON THE DRAWINGS).
- 3) WHERE POSSIBLE, THE CONTRACTOR IS TO USE COLOR CODE FOR ALL WIRING.
- 4) SMOKE DETECTORS ARE NOT TO BE MOUNTED WITHIN 3 FEET OF AIR OUTLETS.
- 5) CONTRACTOR MUST NOT INSTALL SMOKE DETECTOR HEADS IN BASES OR DUCT HOUSING UNTIL FINAL CHECKOUT TIME TO ENSURE THAT DIRT OR DUST DOES NOT CONTAMINATE THE UNITS. DIRTY DETECTORS ARE NOT COVERED BY WARRANTY.
- 6) DO NOT POWER-UP SYSTEM UNTIL JOHNSON CONTROLS FACTORY TECHNICIAN IS PRESENT.
- 7) A SEPARATE GROUND (ISOLATION FROM CONDUIT GROUND) MUST BE PULLED TO ALL CABINETS.
- 8) LOADS GREATER THAN 10 AMPS (FOR AUXILIARY FUNCTIONS) ARE NOT ALLOWED IN THE SAME CONDUIT AS FIRE ALARM.
- 9) CONTRACTOR IS TO ENSURE THAT ALL WIRING AND SHIELDS ARE FREE OF SHORTS, GROUNDS AND OPENS.
- 10) UNDERGROUND WIRING MUST MAINTAIN ONE MEGAOHM, 20F RESISTANCE TO GROUND.
- 11) ANY MANUFACTURER'S RECOMMENDATION IN CONFLICT WITH ENGINEERING DRAWINGS OR SPECIFICATIONS SHALL BE BROUGHT TO THE ATTENTION OF THE ENGINEER FOR CLARIFICATION. CONTRACTOR SHALL ADVISE JOHNSON CONTROLS OF ANY CHANGES.
- 12) PROTECTIVE COVERS ON SMOKE DETECTORS ARE NOT TO BE REMOVED UNTIL OWNERS ACCEPTANCE OF THE SYSTEM. (PREVENTS CONTAMINATION OF SMOKE CHAMBER).
- 13) IT IS THE CONTRACTOR'S RESPONSIBILITY TO REQUEST THE STATE OR LOCAL FIRE MARSHAL TO BE ON SITE FOR FINAL ACCEPTANCE AND CHECK OUT IF REQUIRED.
- 14) IT IS THE CONTRACTOR'S RESPONSIBILITY TO INVENTORY ALL EQUIPMENT RECEIVED FROM JOHNSON CONTROLS AGAINST THE CONTRACT DOCUMENTS AND REPORT ANY DISCREPANCIES WITHIN THIRTY (30) DAYS OR JOHNSON CONTROLS WILL ASSUME THE ORDER TO BE ACCURATE AND COMPLETE.
  - a) \*NOTE: IN THE EVENT OF DISCREPANCIES IN THE NUMBER OF DEVICES SUPPLIED, THE FOLLOWING JOHNSON CONTROLS POLICY WILL APPLY:
    - i) TOO FEW DEVICES: IF THE DEVICE IS SHOWN ON THE CONTRACT DOCUMENTS AND HAS NOT BEEN ADDED AS A RESULT OF A POST BID ADDITION OR CHANGE ORDER, JOHNSON CONTROLS WILL SUPPLY THE DEVICE AT NO CHARGE TO THE CONTRACTOR OR END USER PER JOHNSON CONTROLS'S CONTRACT OBLIGATIONS.
    - ii) TOO MANY DEVICES: IF THE DEVICE SHOWN IS EXTRA, DUE TO A POST BID ADDITION OR CHANGE ORDER; IT REMAINS THE PROPERTY OF THE CONTRACTOR OR END USER. IF THE DEVICE IS EXTRA DUE TO AN ERROR IN QUANTITIES SUPPLIED, THE DEVICE MUST BE RETURNED TO JOHNSON CONTROLS. NO CREDIT WILL BE ISSUED FOR THE RETURN OF EXTRA EQUIPMENT ABOVE THE QUANTITIES GIVEN IN THE CONTRACT DOCUMENTS.
- 15) OWNERS PRESENCE FOR FINAL DEMONSTRATION AND ACCEPTANCE.



## Special Instructions - Johnson Controls

- 1) JOHNSON CONTROLS WILL PROVIDE WIRING INSTRUCTIONS FOR INSTALLATION OF JOHNSON CONTROLS EQUIPMENT.
- 2) JOHNSON CONTROLS WILL PROVIDE A FACTORY TRAINED TECHNICIAN TO ASSIST IN TRAINING:
  - a) OPERATION OF THE CONTROL PANEL AND FUNCTIONS
  - b) ALARM TEST OF ALL JOHNSON CONTROLS PERIPHERAL DEVICES (SMOKE DETECTOR, MANUAL PULL STATION, ETC.)
  - c) SUPERVISE TEST OF ALL INITIATING, SIGNALING, AND CONTROL CIRCUITS.
- 3) JOHNSON CONTROLS WILL PROVIDE (1) INSTRUCTION AT FINAL TEST OF THE SYSTEM TO:
  - a) OWNER REPRESENTATIVE
  - b) FIRE INSPECTOR AND ELECTRICAL INSPECTOR
  - c) ARCHITECT AND ENGINEER
- 4) UPON COMPLETION OF FINAL TEST, JOHNSON CONTROLS WILL PROVIDE:
  - a) TEST REPORT
  - b) CERTIFICATION (IF REQUIRED)
  - c) ONE YEAR WARRANTY





## Testing Procedure for Devices

### **GENERAL:**

FOR ALL DEVICES (SUPPLIED BY JOHNSON CONTROLS) VISUALLY VERIFY PROPER LOCATION AND INSTALLATION.

### **SMOKE DETECTOR:**

ACTIVATE THE DEVICE USING A SMOKE GENERATOR AND VERIFY ALARM CONDITION ON PANEL. RESET PANEL AND VERIFY RESET OF SMOKE DETECTOR AND PANEL. TEST FOR ALARM VERIFICATION IF APPROPRIATE.

### **HEAT DETECTOR:**

FIXED TEMPERATURE REPLACEMENT ELEMENT - REMOVE ELEMENT ON HEAT DETECTOR TO INITIATE ALARM AND VERIFY ALARM CONDITION AT PANEL. REINSTALL ELEMENT, RESET SYSTEM, AND VERIFY.

NON-REPLACEABLE ELEMENT - NON-REPLACEABLE ELEMENT HEAT DETECTORS CAN ONLY BE TESTED FOR CONTINUITY.

RATE-OF-RISE DETECTORS - RATE OF RISE DETECTORS ARE TESTED WITH A HEATER OR BLOW DRYER UNTIL THEY INITIATE ALARM, THEN ALLOWED TO COOL. RESET PANEL AND VERIFY.

### **PULL STATIONS:**

ACTIVATE STATION WITH THE T-HANDLE, VERIFY ALARM AND LABEL FOR LOCATION, RESET STATION, RESET PANEL.

### **DUCT DETECTOR:**

(IF PROVIDED BY JOHNSON CONTROLS) WITH AIR HANDLING UNIT TURNED ON, OPEN ONE OF THE TEST PORT HOLES BY REMOVING THE RED COVER ON THE DUCT DETECTOR/SENSOR HOUSING. USING AN EXTENDED NOZZLE ON THE SMOKE DETECTOR AEROSOL TESTER SPRAY A FOUR TO EIGHT SECOND BURST OF AEROSOL THROUGH THE TEST PORT BUT NOT DIRECTLY AT THE DETECTOR/SENSOR HEAD. THE NOZZLE OF THE SMOKE DETECTOR AEROSOL TESTER SHOULD NOT EXTEND BEYOND THE INLET TUBE. AEROSOL IS SPRAYED INTO THE STREAM OF INCOMING AIR AND NOT DIRECTLY INTO DETECTOR/SENSOR. VERIFY ALARM, TEST ALL INDICATORS OR MANUAL TEST SWITCHES, RESET DETECTOR, RESET PANEL, TEST SAMPLE AND REFERENCE TUBE FOR POSITIVE AIR FLOW. (IF NOT PROVIDED BY JOHNSON CONTROLS) VERIFY THAT ZONE CIRCUIT IS PRESENT AT THE DEVICE.

### **AUDIBLES AND VISIBLES:**

ACTIVATE ALARM AND CONFIRM THAT ALL INDICATING APPLIANCES, AUDIBLES AND VISIBLES, ARE OPERATING.

### **DOOR HOLDERS:**

VERIFY THAT DOORS CLOSE ON ALARM.

### **VALVE SUPERVISORY SWITCHES (TAMPER):**

(IF PROVIDED BY JOHNSON CONTROLS) ACTIVATE SWITCH BY MOVING VALVE OFF NORMAL, VERIFY STATUS CHANGE, RESET SWITCH, RESET PANEL. (IF NOT PROVIDED BY JOHNSON CONTROLS) VERIFY THAT ZONE CIRCUIT IS PRESENT AT THE SWITCH.

### **FLOW SWITCHES AND PRESSURE SWITCHES:**

(IF PROVIDED BY JOHNSON CONTROLS) ACTIVATE SWITCH (WITH SPRINKLER CONTRACTOR PRESENT) BY A FLOW OF WATER, VERIFY STATUS CHANGE, RESET SWITCHES, RESET PANEL. (IF NOT PROVIDED BY JOHNSON CONTROLS) VERIFY THAT ZONE CIRCUIT IS PRESENT AND SUPERVISED AT THE SWITCH.

### **FAN/DAMPER CONTROL CIRCUITS:**

VERIFY (WITH HVAC CONTRACTOR PRESENT) THAT THE CONTROL CIRCUIT IS OPERATING, AND THE DEVICES IS BEING CONTROLLED IN ACCORDANCE WITH THE SPECIFIED SEQUENCE OF OPERATION.

### **ELEVATOR CONTROL CIRCUITS:**

VERIFY (WITH ELEVATOR CONTRACTOR PRESENT) THAT THE ELEVATOR IS BEING CONTROLLED IN ACCORDANCE WITH THE SPECIFIED SEQUENCE OF OPERATION.

### **TRAINING:**

JOHNSON CONTROLS SHALL PROVIDE A ONE TRAINING SESSION TO THE CUSTOMER.

### **WARRANTY:**

THE SYSTEM SHALL BE PROVIDED WITH A ONE YEAR HARDWARE WARRANTY.



**This Page Left Blank Intentionally**



# Equipment List Bill of Material Fire Alarm System

<u>Quantity</u>	<u>Product ID</u>	<u>Product Description</u>
8	NEW DEVICES	New Devices To Be Installed
5	4098-9714	Addr. Photoelectric Smoke Sensor
5	4098-9792	Standard Base
3	4906-9154	Conv. Multi-Cd Spkr/Strb ,Ceiling, White, Clear, Fire
2	EXISTING/REUSED	Devices Below Are Existing And To Be Relocated/Reused
1	4098-9714	Addr. Photoelectric Smoke Sensor
1	4098-9792	Standard Base
1	4906-9154	Conv. Multi-Cd Spkr/Strb ,Ceiling, White, Clear, Fire

**Equipment List Subject to Change.**



**This Page Left Blank Intentionally**

**Equipment List Subject to Change.**

## Features

### TrueAlarm analog sensing

You can use TrueAlarm analog sensing to digitally transmit analog sensor values with IDNet or MAPNET II two-wire communications.

You can use True Alarm analog sensing with the following Simplex products:

- 4007ES, 4010, 4010ES, 4100ES, and 4100U series fire alarm control units (FACUs), and 4008 series FACUs with reduced feature set.
- 4020, 4100, and 4120 series FACUs, Universal Transponders, and 2120 TrueAlarm CDTs equipped for MAPNET II operation

### Features compatible with the FACU

- Peak value logging with accurate analysis of each sensor for individual sensitivity selection
- Sensitivity monitoring meets NFPA 72 sensitivity testing requirements. The automatic individual sensor calibration check verifies sensor integrity
- Automatic environmental compensation, multi-stage alarm operation, and display of sensitivity directly in percent for each foot
- Display and print detailed sensor information in English

### Photoelectric smoke sensors features

- Sensitivity levels from 0.2% to 3.1%. See [TrueAlarm sensors](#) for more information.

### Heat sensors features

- Three fixed temperature sensing thresholds: 135°F, 155°F and 190°F
- Rate-of-rise temperature sensing
- Utility temperature sensing
- Listed to UL 521 and ULC-S530

### General features

- Ceiling or wall mounting
- Listed to UL 268 7th Edition and ULC-S529
- NEMA 1 rated. See [TrueAlarm analog sensing product selection chart](#) for more information.
- Louvered smoke sensor design enhances smoke capture by directing flow to chamber. Entrance areas are minimally visible when ceiling mounted
- Designed for EMI compatibility
- Magnetic testing
- Different bases support a supervised or unsupervised output relay, or a remote LED alarm indicator

### Additional base reference

- For isolator bases, refer to data sheet [S4098-0025](#)
- For isolator2 bases, refer to data sheet [S4098-0026](#)
- For sounder bases, refer to data sheet [S4098-0028](#)
- For photo/heat sensors, refer to data sheet [S4098-0024](#), single address and [S4098-0033](#), dual address

## Description

### Digital communication of analog sensing

TrueAlarm analog sensors provide an analog measurement digitally communicated to the host control panel using Simplex addressable communications. The control unit analyses the data, determines an average value, and stores it. Comparing the sensor's present value against its average value and time, determines an alarm or other abnormal condition.

### Intelligent data evaluation

Monitoring each sensor's average value provides a continuously shifting reference point. A software filtering process compensates for environmental factors, such as dust and dirt, and component aging, to provide an accurate reference for evaluating new activity. This reduces the probability of false or nuisance alarms caused by shifts in sensitivity.

### Control unit selection

The control unit stores peak activity for each sensor for evaluating specific locations. The host control unit determines the alarm set point for each TrueAlarm sensor, selectable as more or less sensitive as the individual application requires.

Figure 1: **4098-9714** TrueAlarm photoelectric sensor mounted in base

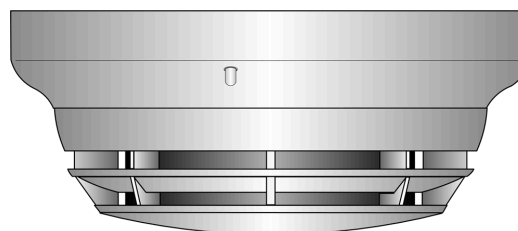

### Timed/multi-stage selection

You can program the sensor alarm set points for timed automatic sensitivity selection, such as more sensitive at night or less sensitive during day. You can program the control unit to provide multi-stage operation for each sensor.

### Sensor alarm and trouble LED indication

Each sensor base's LED pulses to indicate communications with the unit. If the control unit determines a sensor is in alarm, is dirty, or has some other type of trouble, the details display at the control unit and the sensor's base LED turn on steadily. During a system alarm, an LED indicating a trouble returns to pulsing to help identify the alarmed sensors.

## TrueAlarm sensor bases and accessories

### Sensor base features

#### Base mounted address selection

- Address remains with its programmed location
- Accessible from front, DIP switch under sensor

#### General features

- Automatic identification provides default sensitivity when substituting sensor types
- Integral red LED for power-on, pulsing, or alarm or trouble, steady on
- Locking anti-tamper design mounts on standard outlet box
- Magnetically-operated functional test

\* These products have been approved by the California State Fire Marshal (CSFM) pursuant to Section 13144.1 of the California Health and Safety Code. See CSFM Listings 7272-0026:218, 7271-0026:231, 7270-0026:216, and 7300-0026:217 for allowable values and/or conditions concerning material presented in this document. Additional listings may be applicable, contact your local Simplex product supplier for the latest status. Listings and approvals under Simplex Time Recorder Co. are the property of Tyco Fire Protection Products.

## Sensor bases

### 4098-9792, standard sensor base

### 4098-9789, sensor base with wired connections

- 2098-9808 remote LED alarm indicator or 4098-9822 relay. The relay is unsupervised and requires separate 24 VDC.

### Supervised relay bases not compatible with 2120 CDT:

- **4098-9791, four-wire sensor base**, use with remote or locally mounted 2098-9737 relay, requires separate 24 VDC
- **4098-9780, two-wire sensor base**, use with remote or locally mounted 4098-9860 relay, no separate power required
- You can program supervised relay operation, and manually operate it from the control unit
- Includes wired connections for remote LED alarm indicator **or** 4098-9822 relay, relay is unsupervised and requires separate 24 VDC

## Sensor base options

### 2098-9737, remote or local mount supervised relay

- DPDT contacts for resistive or suppressed loads
- power limited rating of 3 A at 28 VDC
- non-power limited rating of 3 A at 120 VAC, requires external 24 VDC coil power

### 4098-9860, remote or local mount supervised relay

- SPDT dry contacts, power limited rating of 2 A at 30 VDC, resistive. Non-power limited rating of 0.5 A at 125 VAC, resistive

### 4098-9822, LED annunciation relay

- Activates when base LED is on steady, indicating local alarm or trouble
- DPDT contacts for resistive or suppressed loads, power limited rating of 2 A at 28 VDC. Non-power limited rating of 1/2 A at 120 VAC, requires external 24 VDC coil power

### 4098-9832, adapter plate

- Required for surface or semi-flush mounting to 4 in. square electrical box and for surface mounting to a 4 in. octagonal box
- You can use the 4098-9832 adapter plate for cosmetic retrofitting to an existing 6 3/8 in. diameter base product

### 2098-9808, remote red LED alarm indicator

- Mounts on single gang box

Figure 2: Remote red LED alarm indicator

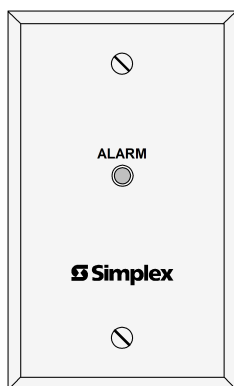

## Description

TrueAlarm sensor bases contain integral addressable electronics that monitor the status of the detachable photoelectric or heat sensors. The sensors transmit digitalized output to the system fire alarm control unit every four seconds.

You can change different TrueAlarm sensor types to meet location requirements. You can use this feature to substitute sensors during building construction. When conditions are temporarily dusty, you can install heat sensors without reprogramming the control unit. Although the control unit indicates an incorrect sensor type, the heat sensor operates at a default sensitivity and provides heat detection for building protection at that location.

## Mounting reference

Figure 3: Mounting reference

### Electrical Box Requirements: (boxes are by others)

**Without relay in the box:** 4" octagonal or 4" square, 1-1/2" deep; single gang, 2" deep

**With relay in the box:** 4" octagonal or 4" square, 1-1/2" deep, with 1-1/2" extension ring

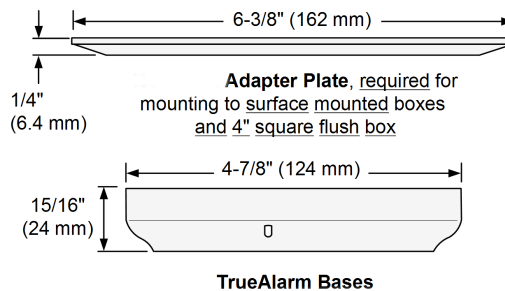
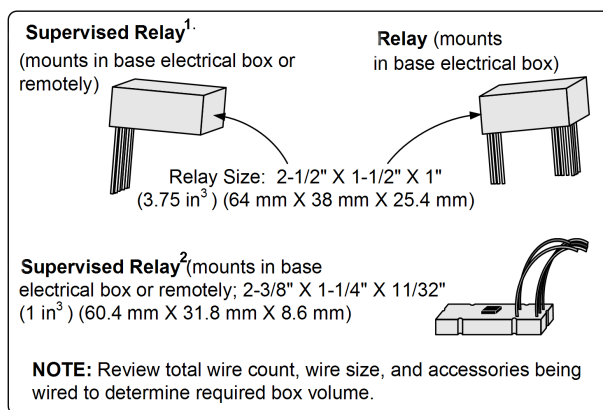
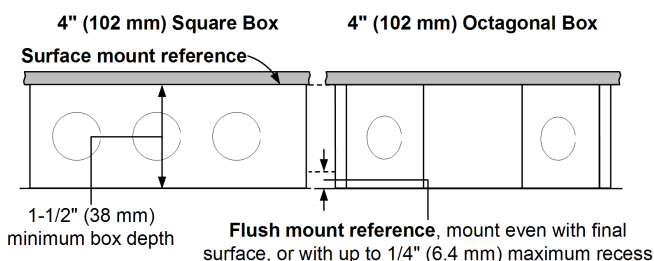

Table 1: Product mounting - SKU reference

Product	SKU
Relay	4098-9822
Supervised relay	Example 1 2098-9739 Example 2 4098-9860
Adapter plate	4098-9832
TrueAlarm bases	4098-9780, 4098-9789, 4098-9791, 4098-9792

## TrueAlarm sensors

### Features

- Sealed against rear air flow entry
- Interchangeable mounting
- EMI/RFI shielded electronics
- Heat sensors:
  - Selectable rate-compensated, fixed temperature sensing with or without rate-of-rise operation

**Table 2: Rated spacing distance between sensors**

Fixed Temp. Setting	UL and ULC Spacing	FM Spacing, Either Fixed Temperature Setting
135°F (57.2°C) 190°F (88°C)	60 ft x 60 ft (18.3 m)	20 ft x 20 ft (6.1 m) for fixed temperature only. RTI = Quick
155°F (68°C)	40 ft x 40 ft (12.2 m)	50 ft x 50 ft (15.2 m) for fixed temperature with either rate-of-rise selection. RTI = Ultra Fast

**Note:** 190°F (88°C) ratings only apply to the 4098-9734 sensor.

### Smoke sensors

- Photoelectric technology sensing
- 360° smoke entry for optimum response
- Built-in insect screens

### 4098-9714 photoelectric sensor

TrueAlarm photoelectric sensors use a stable, pulsed LED light source and a silicon photodiode receiver to deliver low power smoke sensing. There are three user-selectable sensitivities for special applications for each individual sensor: 0.2%, 0.5%, and 1% for each foot. Standard sensitivity is 1.25% to 3.1% for each foot. The fire alarm control unit can vary the sensitivity for normal applications between 1.25% and 3.1% for each foot.

**Note:** Fixed sensitivity settings higher than 1.0% for each foot are not UL268 7th Edition compliant.

The sensor head design provides 360° smoke entry for response to smoke from any direction. Due to its photoelectric operation, air velocity is not normally a factor, except for impact on area smoke flow.

**Figure 4: 4098-9714 photoelectric sensor with base**

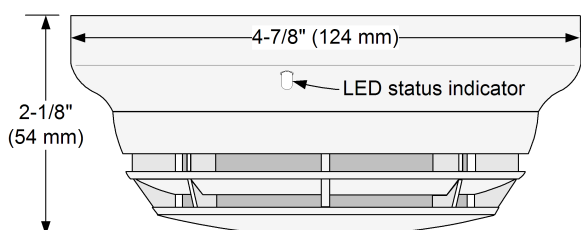

### 4098-9733 and 4098-9734 heat sensors

TrueAlarm heat sensors are self-restoring and provide rate-compensated, fixed temperature sensing with or without rate-of-rise temperature sensing. The sensor measures the local temperature for analysis at the fire alarm control unit.

You can select rate-of-rise temperature detection at the control unit for either 15°F or 20°F, (8.3°C or 11.1°C) for each minute. Fixed temperature sensing is independent of rate-of-rise sensing and you can program it to operate at 135°F or 155°F (57.2°C or 68°C). The 4098-9734 sensor provides an additional 190°F (88°C) set point.

In a slowly developing fire, the temperature may not increase rapidly enough to operate the rate-of-rise feature. However, when the temperature reaches the rated fixed temperature setting, it triggers an alarm.

You can program TrueAlarm heat sensors as a utility device to monitor for temperature extremes in the range of 32°F to 155°F (0°C to 68°C). This feature can provide freeze warnings, or alert you to HVAC system problems. Refer to panel specifications for availability.

**Figure 5: 4098-9733 heat sensor with base**

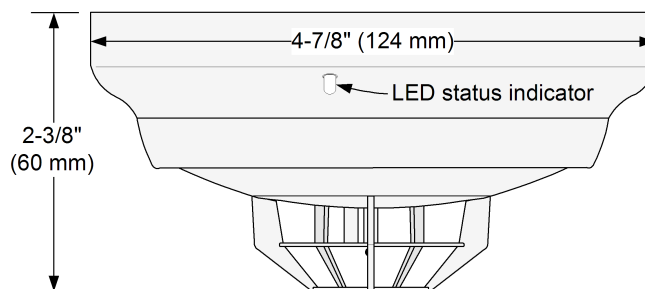

**Figure 6: 4098-9734 high temperature heat sensor with base**

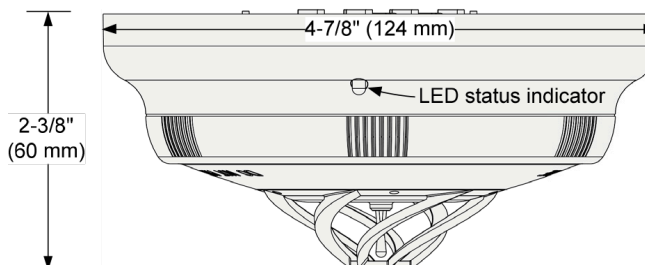

**WARNING:** In most fires, hazardous levels of smoke and toxic gas can build up before a heat detection device would initiate an alarm. In cases where Life Safety is a factor, the use of smoke detection is highly recommended.

### Application reference

Only choose sensor locations after careful consideration of the physical layout and contents of the area that you want to protect. Refer to NFPA 72, *the National Fire Alarm and Signaling Code*. On smooth ceilings, you can use a smoke sensor spacing of 30 ft (9.1 m) as a guide.

For detailed application information including sensitivity selection, refer to *4098 Detectors, Sensors, and Bases Application Manual (574-709)*.

## TrueAlarm analog sensing product selection chart

**Table 3: TrueAlarm sensor bases, for use with sensors 4098-9714 and 4098-9733**

SKU	Color	Description	Compatibility	Mounting requirements
4098-9792	White	Standard sensor base	No options	4 in. octagonal or 4 in. square box, 1 1/2 in. min. depth, or single gang box, 2 in. min. depth
4098-9776	Black			
4098-9789	White	Sensor base with connections for remote LED alarm indicator or unsupervised relay	2098-9808 remote alarm indicator or 4098-9822 unsupervised relay	4 in. octagonal or 4 in. square box <b>Note:</b> Box depth requirements depend on total wire count and wire size. See Table 5
4098-9789IND				
4098-9775	Black			
4098-9791	White	Four-wire sensor supervised relay base with connections for LED indicator or unsupervised relay	2098-9737 supervised remote relay 2098-9808 remote alarm indicator or 4098-9822 unsupervised relay	
<b>Note:</b> NOT compatible with the 2120 CDT				
4098-9780	White	Two-wire sensor supervised relay base with connections for LED indicator or unsupervised relay	4098-9860 supervised remote relay 2098-9808 remote alarm indicator or 4098-9822 unsupervised relay	
<b>Note:</b> NOT compatible with the 2120 CDT				

**Note:** SKU numbers ending in IND are assembled in India.

Refer to *4098 Detectors, Sensors, and Bases Application Manual (574-709)* and *4098 Smoke/Heat Sensor Bases Installation Instructions (574-707)* for additional information.

**Table 4: TrueAlarm sensors**

SKU	Color	Description	Compatibility	Mounting requirements
4098-9714	White	Photoelectric smoke sensor	Bases 4098-9775, 4098-9776, 4098-9792, 4098-9789, 4098-9791, and 4098-9780	Refer to base requirements
4098-9714-IND				
4098-9774	Black			
4098-9733	White	Heat sensor		
4098-9778	Black			
4098-9734	White	High temperature heat sensor		

**Note:**

- SKUs are NEMA 1 rated.
- The 4098-9734 Heat Sensor is only compatible with IDNet on the 4100ES, 4010ES, and 4007ES

**Table 5: TrueAlarm sensor and base accessories**

SKU	Description	Compatibility	Mounting requirements
2098-9737	Supervised relay, mounts remote or in base electrical box	4098-9791 base	Remote mounting requires 4 in. octagonal or 4 in. square box, 1 1/2 in. minimum depth
4098-9860	Supervised relay, mounts remote or in base electrical box	4098-9780 base	Base mounting requires 4 in. octagonal box, 2 1/8 in. deep with 1 1/2 in. extension ring
2098-9808	Remote red LED alarm indicator on single gang stainless steel plate	Bases 4098-9789, 4098-9791, and 4098-9780	Single gang box, 1 1/2 in. minimum depth
4098-9822	Unsupervised relay, tracks base led status. <b>Note:</b> Only mounts in base electrical box.	Bases 4098-9789, 4098-9791, and 4098-9780	4 in. octagonal box, 2 1/8 in. deep with 1 1/2 in. extension ring
4098-9832	Adapter plate	Bases 4098-9792, 4098-9789, 4098-9791, and 4098-9780	Required for surface or semi-flush mounted 4 in. square box and for surface mounted 4 in. octagonal box

**Note:** 2098-9808 is NEMA 1 rated.

## Specifications

**Table 6: General operating specifications**

Specification	Rating
Communications and sensor supervisory power	IDNet or MAPNET II communications, auto-selected, one address for each base
Communications connections	Screw terminals for in/out wiring, 18 to 14 AWG, 0.82 mm <sup>2</sup> to 2.08 mm <sup>2</sup>
Remote LED alarm indicator current	1 mA typical, no impact to alarm current
Remote LED alarm indicator and relay connections	Color coded wire leads, 18 AWG, 0.82 mm <sup>2</sup>
UL listed operating temperature range	32°F to 100°F, 0°C to 38°C



**Table 6: General operating specifications**

Specification		Rating
Operating temperature range	with 4098-9733 Heat Sensor	32°F to 122°F, 0°C to 50°C
	with 4098-9714 Smoke Sensor	15°F to 122°F, -9°C to 50°C
	with 4098-9734 Heat Sensor	32°F to 150°F, 0°C to 66°C
Storage temperature range		0°F to 140°F, -18°C to 60°C
Humidity range		10% to 95% RH
4098-9714 smoke sensor air velocity rating		0 to 4000 ft/min, 0 to 1220 m/min
Housing color		Frost white or black

**Table 7: 4098-9791 Base with supervised remote relay 2098-9737**

Specification		Rating
Externally supplied relay coil voltage		18 VDC to 32 VDC, nominal 24 VDC
Supervisory current		270 $\mu$ A, from 24 VDC supply
Alarm current with 2098-9737 relay		28 mA, from 24 VDC supply
<b>Note:</b> See <a href="#">Sensor base options</a> for contact ratings.		

**Table 8: 4098-9780 Base with supervised remote relay 4098-9860**

Specification		Rating
Power		Supplied from communications

**Table 9: 4098-9822 Unsupervised relay, requirements for bases 4098-9789, 4098-9791, and 4098-9780**

Specification		Rating
Externally supplied relay coil voltage		18 VDC to 32 VDC, nominal 24 VDC
Supervisory current		Supplied from communications
Alarm current		13 mA from separate 24 VDC supply
<b>Note:</b> See <a href="#">Sensor base options</a> for contact ratings.		



**Features**

**Speaker/visible (S/V) notification appliances with multi-tapped speaker and multi-tapped high intensity xenon strobe with synchronized flash:**

- Rugged, high impact, flame retardant thermoplastic housings are available for wall or ceiling mount
- Operation is compatible with ADA requirements (see [Wall mount installation reference](#))

**Wall mount S/V features:**

- Housings are available in red or white with clear lens with contrasting white or red **FIRE** lettering
- Covers are available separately to convert housing color

**Ceiling mount S/V features:**

- Housing is white with clear lens
- Red **FIRE** lettering is printed on two sides

**Audible notification appliance (speaker):**

- High quality voice and tone reproduction with taps for 1/4 W, 1/2 W, 1 W, or 2 W, at 25 VRMS or 70.7 VRMS
- Capacitor input for connection to supervised notification appliance circuits
- Speakers are wired separately from strobe wiring
- UL listed to Standard 1480 and ULC-S541\*
- Compliant with NFPA 72, 520 Hz Low Frequency Signal Requirements for Sleeping Areas

**Visible notification appliance (strobe):**

- 24 VDC xenon strobe; intensity is selectable as 15, 30, 75, or 110 candela with visible selection jumper secured behind strobe housing
- Strobes are activated from NACs selected to provide Simplex strobe synchronization signals or from separate strobe Synchronization Modules that are available for Class B or Class A operation
- Regulated circuit design ensures consistent flash output and provides controlled inrush current
- UL listed to Standard 1971 and ULC-S526\*

**Options for wall mounted S/Vs:**

- Red or white adapters to cover surface mounted electrical boxes
- Red adapter for mounting to 2975-9145 boxes
- Red wire guard

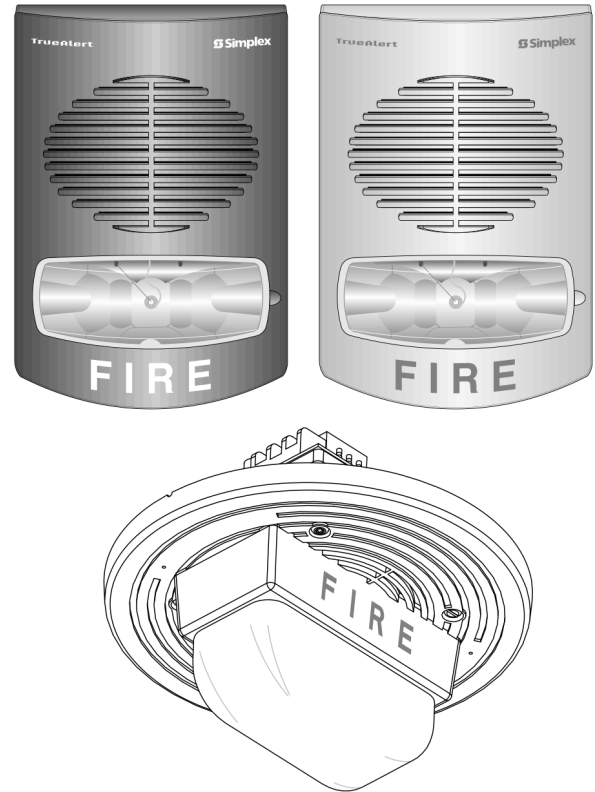

Figure 1: Wall and ceiling mount S/Vs

**Description**

**Multi-Candela TrueAlert S/Vs with speaker and synchronized strobe**

Provide convenient installation to standard electrical boxes with extensions. The enclosure designs are both impact and vandal resistant and provide a convenient strobe intensity selection. You can select each model for strobe intensity output. This minimizes on-site model inventory and easily accommodates changes encountered during construction.

**Wall mount**

S/V housings are a one-piece assembly, including lens, that mounts to a 4 in. square electrical box with extension, see [Wall mount installation reference](#). You can quickly remove the cover with a tool and covers are available separately for color conversion.

**Ceiling mount**

S/Vs also install using 4 in. electrical boxes with an extension. See [Ceiling mount S/V installation reference](#) and 2905-9946 tile bridge dimensions.

**Strobe intensity selection**

During installation, a selection plug at the back of the housing determines the desired strobe intensity. An attached flag with black letters on a highly visible yellow background allows the selected intensity to be seen at the side of the strobe lens.

## Synchronized strobes

### Multiple strobes

When multiple strobes and their reflections can be seen from one location, synchronized flashes reduce the probability of photo-sensitive reactions as well as the annoyance and possible distraction of random flashing. The multi-candela strobes of these S/Vs are activated by NACs that provide the Simplex synchronization format. For additional information, refer to data sheet [S4905-0003](#).

### Strobe application selection

Proper selection of visible notification is dependent on occupancy, location, local codes, and proper applications of: the *National Fire Alarm and Signaling Code* (NFPA 72), ANSI A117.1; the appropriate model building code: BOCA, ICBO, or SBCCI; and the application guidelines of the Americans with Disabilities Act (ADA).

### Product selection

**Table 1: Wall mount multi-candela S/Vs**

Model	Housing Color	FIRE Lettering	Listings	Description	Housing dimensions with lens
4906-9151	Red	White	UL and ULC	Multi-tapped Speaker with Multi-Candela Synchronized Strobe; strobe intensity selectable as: 15 cd, 30 cd, 75 cd, or 110 cd	7 1/4 in. H x 5 in. W x 2 5/8 in. D or 184 mm x 127 mm x 67 mm
4906-9153	White	Red			

**Table 2: Ceiling mount multi-candela S/V**

Model	Housing color	Lettering	Listings	Description	Dimensions
<a href="#">4906-9154</a>	White	Red (FIRE)	UL	Multi-tapped Speaker with Multi-Candela Synchronized Strobe; strobe intensity selectable as: 15 cd, 30 cd, 75 cd, or 110 cd	Housing = 7 1/2 in. or 191 mm diameter, 1/2 in. or 13 mm deep Strobe lens protrusion = 2 5/8 in. or 67 mm above speaker housing Depth into box = 2 3/4 in. or 70 mm
4906-9157	White	Red (FIRE)	ULC		
4906-9158	White	Red (ALERT)	UL		
4906-9159	White	Blank	UL		
4906-9160	Red	White (FIRE)	UL		

**Table 3: Wall mount S/V adapters**

Model	Description	Dimensions
4905-9946	Surface mount red adapter skirt	7 3/4 in. H x 5 3/8 in. W x 3 3/16 in. D or 197 mm x 137 mm x 81 mm depth with S/V = 5 7/8 in. or 149 mm
4905-9947	Surface mount white adapter skirt	
4905-9903	Adapter Plate, red, required to mount S/V on 2975-9145	8 5/16 in. H x 5 3/4 in. W x 0.060 in. Thick or 211 mm x 146 mm x 1.5 mm
2975-9145	Mounting box, red, for surface or flush mount, requires adapter plate 4905-9903 (this box may be available for retrofit applications)	7 7/8 in. H x 5 1/8 in. W x 2 3/4 in. D or 200 mm x 130 mm x 70 mm

**Table 4: Wall mount S/V replacement covers**

Model	Descriptions	Dimensions
4905-9996	Red S/V cover with white <b>FIRE</b> lettering	7 1/4 in. H x 5 in. W x 1 3/8 in. D or 184 mm x 127 mm x 35 mm
4905-9997	White S/V cover with red <b>FIRE</b> lettering	

**Table 5: Synchronized flash control modules**

Model	Description	Dimensions
4905-9914*	Synchronized Flash Module, Class B operation	1 3/8 in. W x 2 7/16 in. L x 13/16 in. H or 35 mm x 62 mm x 20 mm
4905-9922*	Synchronized Flash Module, Class A operation	

**Table 6: Wall mount S/V wire guard**

Model	Description	Dimensions
4905-9998	Wire guard with mounting plate, red, compatible with surface and semi-flush boxes (UL listed by Space Age Electronics Inc.)	8 3/8 in. H x 6 5/16 in. W x 3 1/4 in. D or 213 mm x 154 mm x 79 mm

**Table 7: Ceiling mount tile bridge**

Model	Description	Dimensions
2905-9946	Tile Bridge	See <a href="#">Ceiling mount S/V installation reference and 2905-9946 tile bridge dimensions</a>

\* Refer to data sheet [S4905-0003](#) for additional flash control module information

**S/V specifications**
**Table 8: Common specifications**

Specification	Rating
<b>Environmental</b>	32°F to 122°F or 0°C to 50°C; 10% to 93%, non-condensing at 100°F or 38°C
<b>Connections</b>	Terminal blocks for 18 AWG to 12 AWG or 0.82 mm <sup>2</sup> to 3.31 mm <sup>2</sup> ; two wires for each terminal for in/out wiring

**Table 9: Speaker specifications**

Specification	Rating					
<b>Input voltage</b>	25 VRMS or 70.7 VRMS, see Note 1					
<b>Power taps</b>	1/4 W, 1/2 W, 1 W, and 2 W					
<b>Frequency response</b>	Fire Alarm	400 Hz to 4000 Hz				
	General signaling	125 kHz to 12 kHz				
<b>Speaker output Ratings @ 10 ft or 3 m (see Note 1)</b>	Wattage tap	<b>1/4 W</b>	<b>1/2 W</b>	<b>1 W</b>	<b>2 W</b>	
	UL Listed Models, Reverberant Chamber Test, per UL 1480	76 dBA	79 dBA	82 dBA	85 dBA	
	Wall Mount Models 4906-9151 and 4906-9153, Anechoic Chamber Test, per ULC-S541	77 dBA	80 dBA	83 dBA	86 dBA	
	Ceiling Mount Model 4906-9157, per ULC-S541					
	25 VRMS Input	81.6 dBA	84.3 dBA	87.1 dBA	89.7 dBA	
	70.7 VRMS Input	80.9 dBA	84.1 dBA	87.3 dBA	90.2 dBA	
<b>Polar Dispersion Reference (per ULC-S541 Anechoic Chamber Testing)</b>	<b>Attenuation</b>	<b>Angle</b>		<b>Attenuation</b>	<b>Angle</b>	
	-3 dB	+/- 30° off-axis		-6 dB	+/- 55° off-axis	

**Table 10: Strobe specifications**

Specification	Rating				
<b>Rated voltage range</b>	Regulated 24 VDC; 16 VDC to 33 VDC, see Note 2				
<b>Flash rate and synchronized NAC loading</b>	1 Hz; with up to 35 synchronized strobes maximum for each NAC				
<b>Wall mount</b>	Housing dimensions (with lens)	7 1/4 in. H x 5 in. W x 2 5/8 in. D or 184 mm x 127 mm x 67 mm			
	Maximum RMS current rating per strobe setting	15 cd	30 cd	75 cd	110 cd
		60 mA	94 mA	186 mA	252 mA
	Reference RMS currents at other voltages	18 VDC	<b>53 mA</b>	<b>84 mA</b>	<b>165 mA</b>
24 VDC		<b>40 mA</b>	<b>63 mA</b>	<b>124 mA</b>	<b>168 mA</b>
<b>Ceiling mount</b>	Housing dimensions	Speaker housing = 7 1/2 in. or 191 mm diameter, 1/2 in. deep or 13 mm; lens protrusion above speaker housing = 2 5/8 in. or 67 mm; depth into box = 2 3/4 in. or 70 mm			
	Maximum RMS Current rating per strobe setting	<b>15 cd</b>	<b>30 cd</b>	<b>75 cd</b>	<b>110 cd</b>
		75 mA	125 mA	233 mA	316 mA
	Reference RMS currents at other voltages	18 VDC	<b>67 mA</b>	<b>111 mA</b>	<b>207 mA</b>
24 VDC		<b>50 mA</b>	<b>83 mA</b>	<b>155 mA</b>	<b>211 mA</b>

**Note:**

- Speakers are for connection to conventional fire alarm audio circuits. Anechoic speaker output ratings are typically more representative of actual installed sound output.
- The maximum RMS strobe current listed is the device nameplate rating. Strobe designs are constant wattage and the maximum RMS current rating occurs at the lowest allowable operating voltage. RMS is root mean square and refers to the effective value of a varying current waveform.

**Speaker directional characteristics reference**

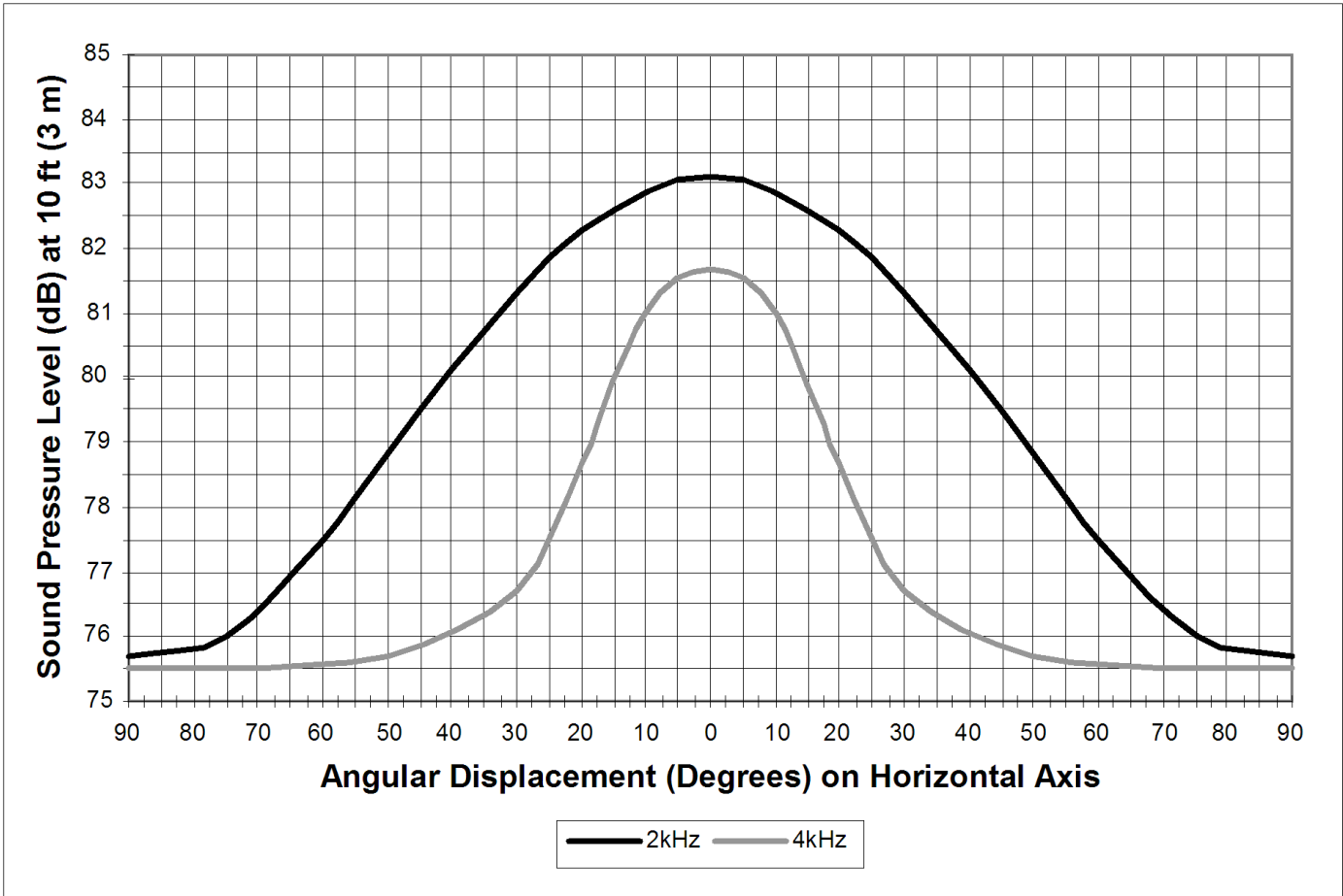
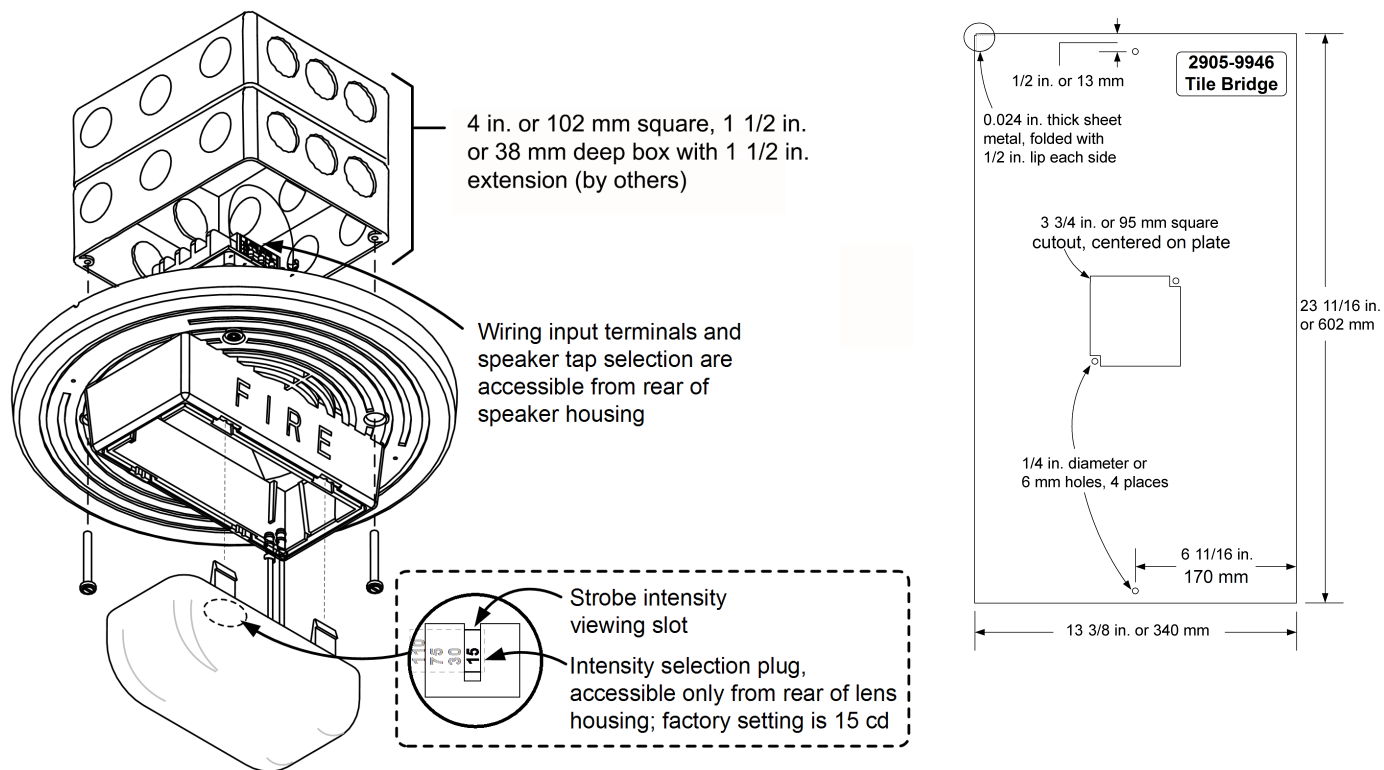

Figure 2: Speaker directional characteristics reference

**Ceiling mount S/V installation reference and 2905-9946 tile bridge dimensions**

Figure 3 shows the mounting of a 4905-9903 Adapter plate to the 2975-9145 box.



**Figure 3: Ceiling mount S/V installation reference and tile bridge dimensions**

The surface mount adapter skirts are available in red (4905-9946) or white (4905-9947)

**Wall mount installation reference**

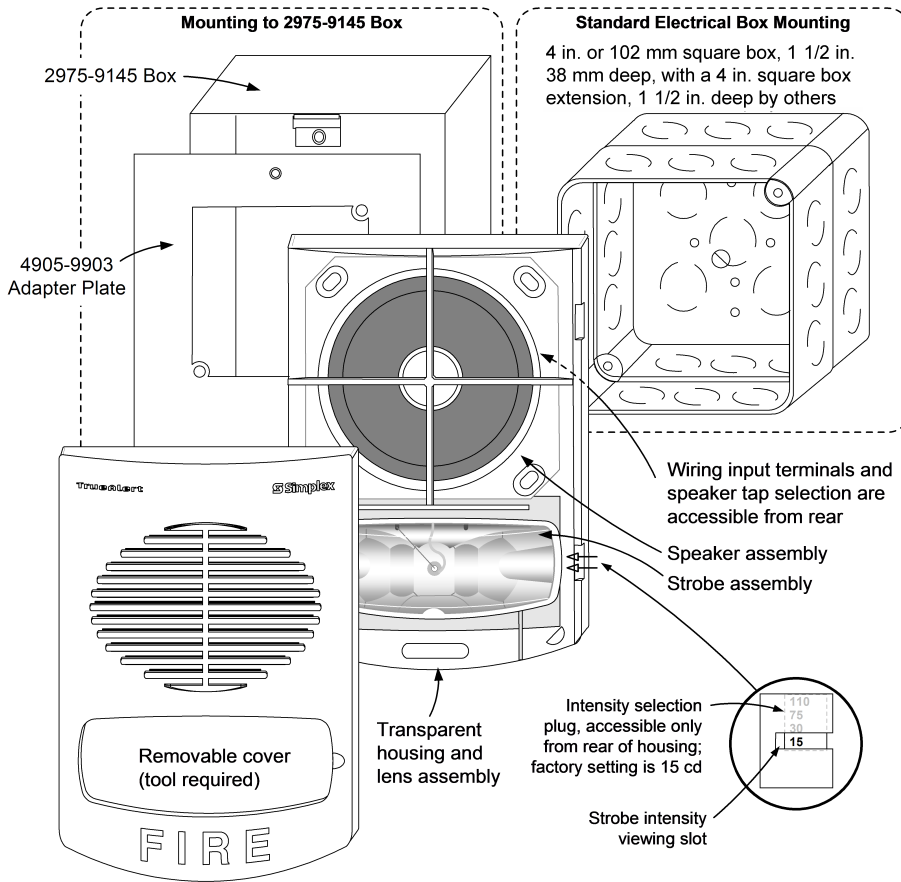

**Figure 4: Wall mount installation reference**

