

THE APPROVED CONSTRUCTION PLANS AND ALL ENGINEERING MUST BE POSTED ON THE JOB AT ALL INSPECTIONS IN A VISIBLE AND READILY ACCESSIBLE LOCATION.
PRINT in COLOR and to SCALE.

Approval of submitted plans is not an approval of omissions or oversight by this office or noncompliance with any applicable regulations of local government. The contractor is responsible for making sure that the building complies with all applicable building codes and regulations of the local government.



SPECIAL PRODUCTS TANK SUPPORTS MACHINERY RACK BLDGS SHEDS WORK PLATFORMS FOOTINGS	CONVEYORS TALL SUPPORTS HEADER STEEL ROBOTIC PLATFORMS PICK MODULES ROOF VERIFICATION	STORAGE RACKS SELECTIVE DRIVE-IN PUSH BACK FLOW RACK CANTILEVER	OTHER SERVICES SEISMIC ANALYSIS PERMIT AQUISITION EGRESS PLANS STATE APPROVALS PRODUCT TESTING TITLE 24	SHELVING METAL METAL/WOOD MOVABLE GONDOLAS LOCKERS CATWALKS	SPECIAL PRODUCTS SHUTTLES VLM VRC CAROUSELS FENCING SYSTEMS MODULAR OFFICES MINI-LOAD SYSTEMS
--	---	---	--	--	--

City of Puyallup
Building
REVIEWED
FOR
COMPLIANCE
 RayC
 05/08/2024
 11:12:51 AM



City of Puyallup
Development & Permitting Services
ISSUED PERMIT

Building	Planning
Engineering	Public Works
Fire	Traffic

LICENSED IN 50 STATES

ANALYSIS OF
 STORAGE RACKS
 FOR
Red Dot Corporation
 2504 E. Main Avenue, Puyallup, WA
Job No. 24-1042

Approved by:

SAL E. FATEEN, P.E.
 4/22/2024



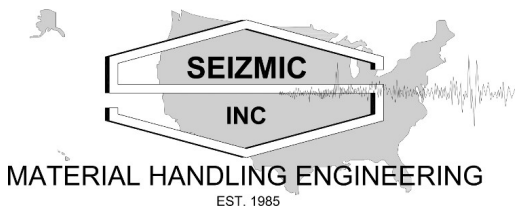

PROJECT: Red Dot Corporation
FOR: Raymond West_Jack Murp
ADDRESS: 2504 E. Main Avenue
Puyallup, WA

SHEET#: 1
CALCULATED BY: ang
DATE: 4/22/2024
PN: 20240415_19

TEL:(909)869-0989
1130 E. CYPRESS ST, COVINA, CA 91724

Table of Contents

Parameters	2
Components and Specifications	3
Loads and Distributions	4
Basic Load Combinations	7
Longitudinal Analysis	8
Column & Backer Analysis	9
Beam Analysis	13
Beam to Column Analysis	16
Bracing Analysis	17
Anchor Analysis	19
Overturning Analysis	22
Baseplate Analysis	23
Slab and Soil Analysis	25

Scope:

This storage system analysis is intended to determine its compliance with appropriate building codes with respect to static and seismic forces.

The storage racks are prefabricated and are to be field assembled only, with no field welding.

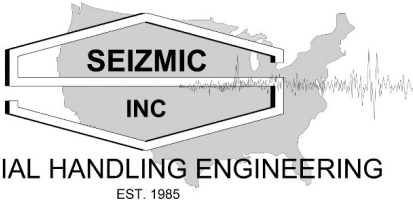

MATERIAL HANDLING ENGINEERING
EST. 1985

TEL: (909) 869-0989
1130 E. CYPRESS ST, COVINA, CA 91724

PROJECT: Red Dot Corporation
FOR: Raymond West_Jack Murp
ADDRESS: 2504 E. Main Avenue
Puyallup, WA

SHEET#: 2
CALCULATED BY: ang
DATE: 4/22/2024
PN: 20240415_19

The storage racks consist of several bays, interconnected in one or both directions, with the columns of the vertical frames being common between adjacent bays. This analysis will focus on a tributary bay to be analyzed in both the longitudinal and transverse direction. Stability in the longitudinal direction is maintained by the beam to column moment resisting connections, while bracing acts in the transverse direction.

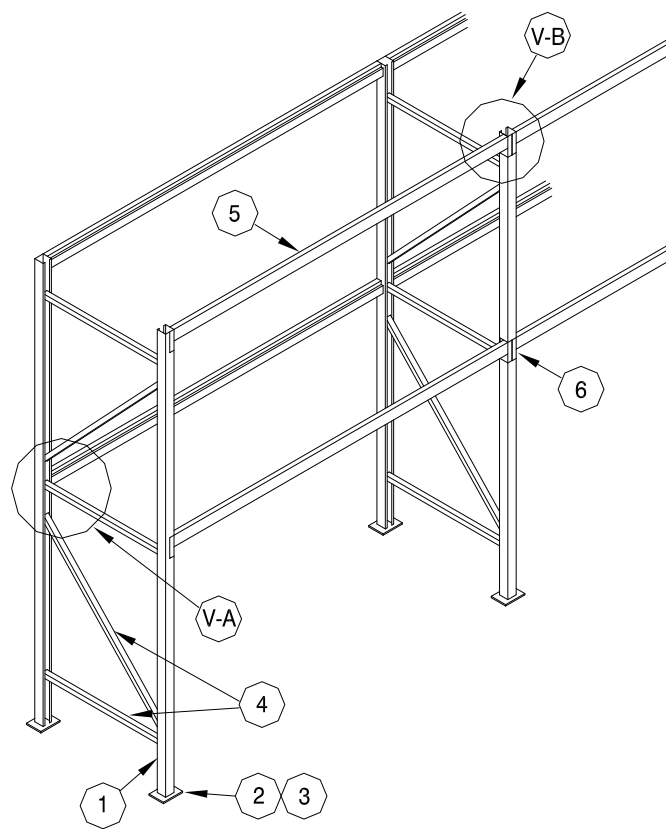

CONCEPTUAL DRAWING

Some components may not be used or may vary

Legend	
1.	Column
2.	Base Plate
3.	Anchors
4.	Bracing
5.	Beam
6.	Connector

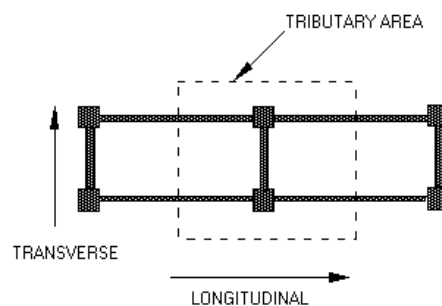

NOTE: ACTUAL CONFIGURATION SHOWN ON COMPONENTS & SPECIFICATIONS SHEET

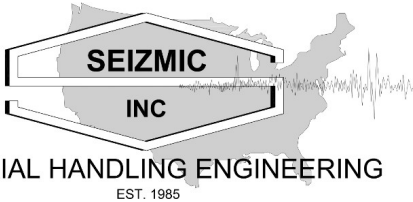

MATERIAL HANDLING ENGINEERING
EST. 1985

TEL: (909) 869-0989
1130 E. CYPRESS ST, COVINA, CA 91724

PROJECT: Red Dot Corporation
FOR: Raymond West_Jack Murp
ADDRESS: 2504 E. Main Avenue
Puyallup, WA

SHEET#: 3
CALCULATED BY: ang
DATE: 4/22/2024
PN: 20240415_19

COMPONENTS AND SPECIFICATIONS Configuration 1: Type A L 1.7

Analysis per section 2209 of the 2021 IBC

Levels: 4 Panels: 6 $S = 1.26$ $F = 1.2$ $I = 1$ $V_{Long} = 828$ lbs. $P_{static} = 10200$ lbs.
 $S_j = 0.43$ $F_v^a = 1.87$ $SDC = D$ $V_{Trans} = 3484$ lbs. $P_{seismic} = 11271$ lbs.

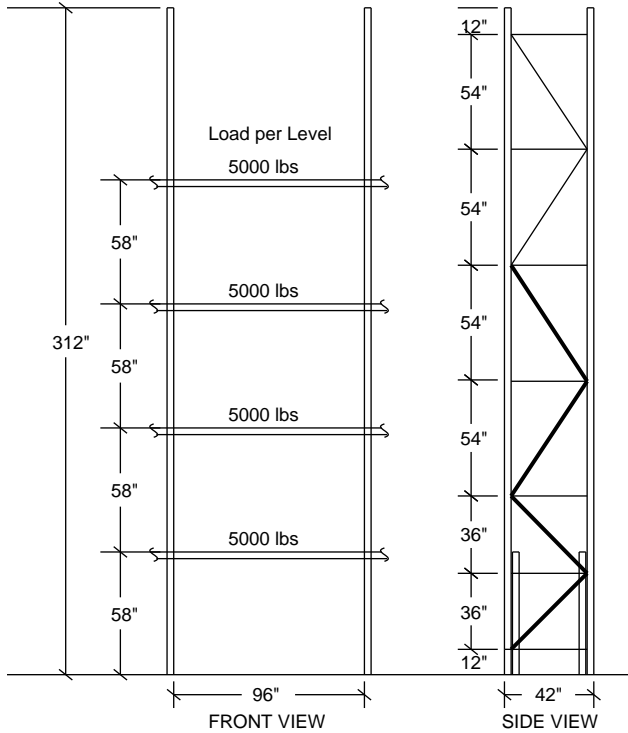

FRAME	BEAM	CONNECTOR
<p>COLUMN 3 x 3 - .075 (LM20) Steel = 55000 psi Stress = 75% (level 2)</p> <p>BACKER TO LEVEL 1 3 x 3 - .075 (LM20) Steel = 55000 psi Stress = 65% (level 1)</p> <p>HORIZONTAL BRACE 1.5 x 1.25 - .075 Stress = 87% (panel 2)</p> <p>DIAGONAL BRACE 1.5 x 1.25 - .075 Stress = 72% (panel 5)</p> <p>1ST-4TH DIAGONAL 1.5 x 1.5 - .075 (Tube) Stress = 87%</p>	<p>4.13 x 2.5 - .060 (SSB416M) Steel = 55 ksi Max Static Cap. = 5458 lb. Stress = 93%</p> <p style="text-align: center;">Max stress = 97% (level 2)</p>	<p>Level 1 4 Pin 2" cc Connector Stress = 55%</p> <p>Level 2 3 Pin 2" cc Connector Stress = 53%</p> <p style="text-align: center;">Max stress = 55% (level 1)</p>
Base Plate	Slab & Soil	Anchors
<p>Steel = 36000 psi 8 x 8 x 0.375 in. 4 anchors/plate Moment = 0 in-lb. Stress = 20%</p>	<p>Slab = 7" x 4000 psi Sub Grade Reaction = 50 pci Slab Bending Stress = 31% (S)</p>	<p>Hilti Kwik Bolt TZ 2 (KB-TZ2) ESR-4266 0.625 in. x 4.5 in. Embed. Pullout Capacity = 2359 lbs. Shear Capacity = 4999 lbs. Anchor stress = 78%</p>

Notes:
1.5 x 1.5" x 14 GA tube brace at diagonals 1-4.

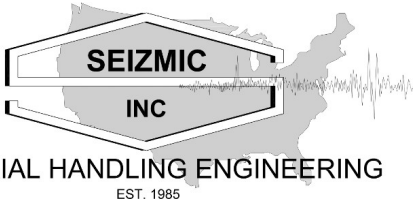

MATERIAL HANDLING ENGINEERING
EST. 1985

TEL: (909) 869-0989
1130 E. CYPRESS ST, COVINA, CA 91724

PROJECT: Red Dot Corporation
FOR: Raymond West_Jack Murp
ADDRESS: 2504 E. Main Avenue
Puyallup, WA

SHEET#: 4
CALCULATED BY: ang
DATE: 4/22/2024
PN: 20240415_19

Loads and Distributions: Type A

Determines seismic base shear per Section 2.6 of the RMI & Section 2209, of the 2021 IBC

# of Levels: 4	SDC: D	R_L : 6	S_s : 1.26
Pallets Wide: 2	W_{PL} : 20000	R_T : 4	S_1 : 0.43
Pallets Deep: 1	W_{DL} : 400 lbs	F_a : 1.2	I_p : 1
Pallet Load: 2500	F_v : 1.87	T_l : 1.5	
Total Frame Load: 20400 lbs			

$$S_{DS} = 2/3 \cdot S_s \cdot F_a = 1.01$$

$$S_{D1} = 2/3 \cdot S_1 \cdot F_v = 0.54$$

$$W_s = 0.67 \cdot W_{PL} + W_{DL} = 13800 \text{ lbs}$$

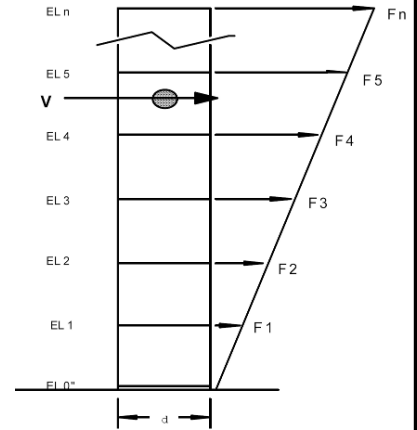

Seismic Shear per RMI 2012 2.6.3:

Longitudinal

Transverse

$$\begin{aligned} V_{long1} &= C_s \cdot I_p \cdot W_s \\ &= S_{D1} / (T_L \cdot R_L) \cdot I_p \cdot W_s \\ &= 0.54 / (1.5 \cdot 6) \cdot 1 \cdot 13800 = 828 \text{ lbs} \end{aligned}$$

V_{long} need not be greater than:

V_{trans} need not be greater than:

$$\begin{aligned} V_{long2} &= C_s \cdot I_p \cdot W_s \\ &= S_{DS} / R_L \cdot I_p \cdot W_s \\ &= 1.01 / 6 \cdot 1 \cdot 13800 = 2323 \text{ lbs} \end{aligned}$$

$$\begin{aligned} V_{trans1} &= C_s \cdot I_p \cdot W_s \\ &= S_{DS} / R_T \cdot I_p \cdot W_s \\ &= 1.01 / 4 \cdot 1 \cdot 13800 = 3484.5 \text{ lbs} \end{aligned}$$

If $S_1 \geq 0.6$, then V_{long} shall not be less than:

If $S_1 \geq 0.6$, then V_{trans} shall not be less than:

$$\begin{aligned} V_{long3} &= C_s \cdot I_p \cdot W_s \\ &= 0.5 \cdot S_1 / R_L \cdot I_p \cdot W_s \\ &= 0.5 \cdot 0.43 / 6 \cdot 1 \cdot 13800 = 497.95 \text{ lbs} \end{aligned}$$

$$\begin{aligned} V_{trans2} &= C_s \cdot I_p \cdot W_s \\ &= 0.5 \cdot S_1 / R_T \cdot I_p \cdot W_s \\ &= 0.5 \cdot 0.43 / 4 \cdot 1 \cdot 13800 = 746.93 \text{ lbs} \end{aligned}$$

V_{long} shall not be less than:

V_{trans} shall not be less than:

$$\begin{aligned} V_{long4} &= C_s \cdot I_p \cdot W_s \\ &= \text{Max}[0.044 \cdot S_{DS}, 0.03] \cdot I_p \cdot W_s \\ &= \text{Max}[0.04, 0.03] \cdot 1 \cdot 13800 = 613.27 \text{ lbs} \end{aligned}$$

$$\begin{aligned} V_{trans3} &= C_s \cdot I_p \cdot W_s \\ &= \text{Max}[0.044 \cdot S_{DS}, 0.5 \cdot S_1 / R_T, 0.03] \cdot I_p \cdot W_s \\ &= \text{Max}[0.04, 0.05, 0.03] \cdot 1 \cdot 13800 = 746.93 \text{ lbs} \end{aligned}$$

Since: $828 \leq 2323$
& $828 \geq 497.95$
& $828 \geq 613.27$
 $V_{long} = 828 \text{ lbs}$

Since: $3484.5 \geq 746.93$
& $3484.5 \geq 746.93$
 $V_{trans} = 3484 \text{ lbs}$

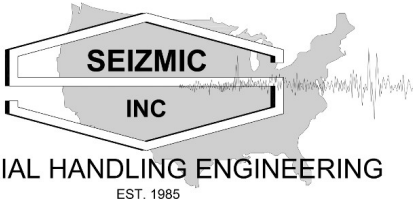

MATERIAL HANDLING ENGINEERING
EST. 1985

TEL: (909) 869-0989
1130 E. CYPRESS ST, COVINA, CA 91724

PROJECT: Red Dot Corporation
FOR: Raymond West_Jack Murp
ADDRESS: 2504 E. Main Avenu
Puyallup, WA

SHEET#: 5
CALCULATED BY: ang
DATE: 4/22/2024
PN: 20240415_19

Loads and Distributions: Type A (Page 2)

$$f_i = V \frac{W_i H_i}{\sum W_i H_i}$$

Level	h_x	Longitudinal			Transverse		
		w_x	$w_x h_x$	f_i	w_x	$w_x h_x$	f_i
1	58	2550	147900	82.8	2550	147900	348.4
2	116	2550	295800	165.6	2550	295800	696.8
3	174	2550	443700	248.4	2550	443700	1045.2
4	232	2550	591600	331.2	2550	591600	1393.6

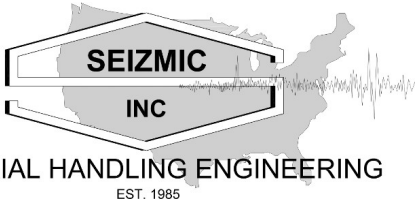

MATERIAL HANDLING ENGINEERING
EST. 1985

TEL: (909) 869-0989
1130 E. CYPRESS ST, COVINA, CA 91724

PROJECT: Red Dot Corporation
FOR: Raymond West_Jack Murp
ADDRESS: 2504 E. Main Avenue
Puyallup, WA

SHEET#: 6
CALCULATED BY: ang
DATE: 4/22/2024
PN: 20240415_19

Fundamental Period of Vibration (Longitudinal)

Per FEMA 460 Appendix A - Development of An Analytical Model for the Displacement Based Seismic Design of Storage Racks in Their Down Aisle Direction

$$T = 2\pi \sqrt{\frac{\sum_{i=1}^{N_L} W_{pi} h_{pi}^2}{g(N_c \left(\frac{k_c k_{be}}{k_c + k_{be}}\right) + N_b \left(\frac{k_b k_{ce}}{k_b + k_{ce}}\right))}} \quad (A-7)$$

Where:

W_{pi} = the weight of the ith pallet supported by the storage rack

h_{pi} = the elevation of the center of gravity of the ith pallet
with respect to the base of the storage rack

g = the acceleration of gravity

N_L = the number of loaded levels

k_c = the rotational stiffness of the connector

k_{be} = the flexural rotational stiffness of the beam-end

k_b = the rotational stiffness of the base plate

k_{ce} = the flexural rotational stiffness of the base upright-end

N_c = the number of beam-to-upright connections

N_b = the number of base plate connections

$$k_{be} = \frac{6EI_b}{L}$$

$$k_{ce} = \frac{4EI_c}{H}$$

$$k_b = \frac{EI_c}{H}$$

L = the clear span of the beams

H = the clear height of the upright

I_b = the moment of inertia about the bending axis of each beam

I_c = the moment of inertia of each base upright

E = the Young's modulus of the beams

Calculated $T = 3.44$

Since the calculated T is greater than 1.5, the more conservative value of 1.5 is used in the calculations

# of levels	4	
min. # of bays	3	
N_c	48	
N_b	8	
k_c	400 kip-in/rad	
k_{be}	2930 kip-in/rad	
k_b	148 kip-in/rad	
k_{ce}	595 kip-in/rad	
I_b	1.59 in ⁴	
L	96 in	
I_c	1.17 in ⁴	
H	232 in	
E	29500 ksi	
Level	h_{pi}	W_{pi}
1	84 in	5 kip
2	142 in	5 kip
3	200 in	5 kip
4	259 in	5 kip

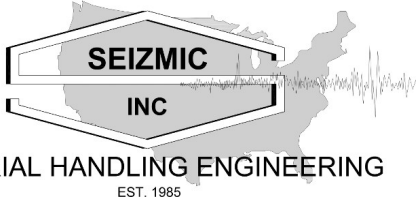

MATERIAL HANDLING ENGINEERING
EST. 1985

TEL: (909)869-0989
1130 E. CYPRESS ST, COVINA, CA 91724

PROJECT: Red Dot Corporation
FOR: Raymond West_Jack Murp
ADDRESS: 2504 E. Main Avenue
Puyallup, WA

SHEET#: 7
CALCULATED BY: ang
DATE: 4/22/2024
PN: 20240415_19

LRFD Basic Load Combinations: Type A

2021 IBC& RMI / ANSI MH 16.1

$$\begin{aligned}
 V_{\text{Trans}} &= 3,484 \text{ lbs} & M_{\text{Trans}} &= \Sigma(f_{\text{Trans}} \cdot h_x) = 606,216 \text{ in-lbs} & \beta &= 0.7 \\
 V_{\text{Long}} &= 828 \text{ lbs} & E_{\text{Trans}} &= M_{\text{Trans}} / \text{frame depth} = 14,433 \text{ lbs} & \beta &= 1.0 \text{ (Uplift combination only)} \\
 P &= \text{Product Load} / 2 = 10,000 \text{ lbs} & & & \rho &= 1 \\
 D &= \text{Dead Load} \cdot 0.5 = 200 \text{ lbs} & & & S_{\text{DS}} &= 1.01
 \end{aligned}$$

$$\begin{aligned}
 L &= \text{Live Load} = 0 \text{ lbs} & S &= \text{Snow Load} = 0 \text{ lbs} & R &= \text{Rain Load} = 0 \text{ lbs} \\
 L_r &= \text{Live Roof Load} = 0 \text{ lbs} & W &= \text{Wind Load} = 0 \text{ lbs}
 \end{aligned}$$

Basic Load Combinations

1. **Dead Load** = 1.4 D + 1.2 P
= (1.4 · 200) + (1.2 · 10,000) = **12,280 lbs**
2. **Gravity Load** = 1.2 D + 1.4 P + 1.6 L + 0.5 (L_r or S or R)
= (1.2 · 200) + (1.4 · 10,000) + (1.6 · 0) + (0.5 · 0) = **14,240 lbs**
3. **Snow/Rain** = 1.2D + 0.85P + (0.5L or 0.5W) + 1.6(L_r or S or R)
= (1.2 · 200) + (0.85 · 10,000) + (0.5 · 0) + (1.6 · 0) = **8,740 lbs**
4. **Wind Load** = 1.2D + 0.85P + 0.5L + 1.0W + 0.5(L_r or S or R)
= (1.2 · 200) + (0.85 · 10,000) + (0.5 · 0) + (1.0 · 0) + (0.5 · 0) = **8,740 lbs**
- 5A. **Seismic Load (Transverse)** = (1.2 + 0.2S_{DS})D + (1.2 + 0.2S_{DS})βP + 0.5L + ρE_{Trans} + 0.2S
= (1.2 + 0.2 · 1.01) · 200 + (1.2 + 0.2 · 1.01) · 0.7 · 10,000 + 0.5 · 0 + 1 · 14,433 + 0.2 · 0 = **24,528 lbs**
- 5B. **Seismic Load (Longitudinal)** = (1.2 + 0.2S_{DS})D + (1.2 + 0.2S_{DS})βP + 0.5L + ρE_{Long} + 0.2S
= (1.2 + 0.2 · 1.01) · 200 + (1.2 + 0.2 · 1.01) · 0.7 · 10,000 + 0.5 · 0 + 1 · 0 + 0.2 · 0 = **10,094 lbs**
6. **Wind Uplift** = 0.9D + 0.9P_{app} + 1.0W
= 0.9 · 200 + 0.9 · 10,000 + 1.0 · 0 = **180 lbs**
7. **Seismic Uplift** = (0.9 - 0.2S_{DS})D + (0.9 - 0.2S_{DS})βP_{app} - ρE_{Trans}
= (0.9 - 0.2 · 1.01) · 200 + (0.9 - 0.2 · 1.01) · 1 · 10,000 - 1 · 14,433 = **-7,314 lbs**
For a single beam, D = **32 lbs** P = **2,500 lbs** I = **312 lbs**
See Base Plate tension Analysis for Over-Strength factor application.
8. **Product/Live/Impact** = 1.2D + 1.6L + 0.5(SorR) + 1.4P + 1.4I
(1.2 · 32) + (1.6 · 0) + (0.5 · 0) + (1.4 · 2,500) + (1.4 · 312) = **3,975 lbs**

ASD Load Combinations for Slab Analysis

1. (1 + 0.105S_{DS})D + 0.75((1.4 + 0.14S_{DS})βP + 0.7ρE)
= (1 + 0.105 · 1.01) · 200 + 0.75((1.4 + 0.14 · 1.01) · 0.7 · 10,000 + 0.7 · 1 · 14,433) = **15,891 lbs**
2. (1 + 0.14S_{DS})D + (0.85 + 0.14S_{DS})βP + 0.7ρE
= (1 + 0.14 · 1.01) · 200 + (0.85 + 0.14 · 1.01) · 0.7 · 10,000 + 0.7 · 1 · 14,433 = **17,271 lbs**
3. D + P
= 200 + 10,000 = **10,200 lbs**

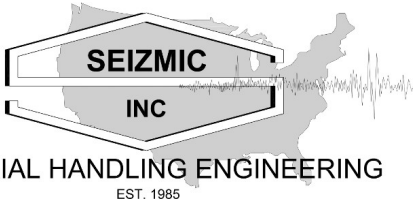

MATERIAL HANDLING ENGINEERING
EST. 1985

TEL: (909) 869-0989
1130 E. CYPRESS ST, COVINA, CA 91724

PROJECT: Red Dot Corporation
FOR: Raymond West_Jack Murp
ADDRESS: 2504 E. Main Avenue
Puyallup, WA

SHEET#: 8
CALCULATED BY: ang
DATE: 4/22/2024
PN: 20240415_19

Longitudinal Analysis: Type A

This analysis is based on the Portal Method, with the point of contra flexure of the columns assumed at mid-height between beams, except for the lowest portion, where the base plate provides only partial fixity and the contra flexure is assumed to occur closer to the base (or at the base of pinned condition, where the base plate cannot carry moment).

$$M_{ConnR} = M_{ConnL} = M_{Conn}$$

$$M_{Conn} = ((M_{Upper} + M_{Lower}) / 2) + M_{Ends}$$

$$V_{Col} = V_{Long} / \# \text{ of columns} = 414 \text{ lbs}$$

$$M_{Base} = 0 \text{ in-lbs}$$

$$M_{Lower} = ((V_{col} \cdot h_i) - M_{Base})$$

$$(414 \text{ lbs} \cdot 56 \text{ in.}) - 0 \text{ in-lbs} = 23184 \text{ in-lbs}$$

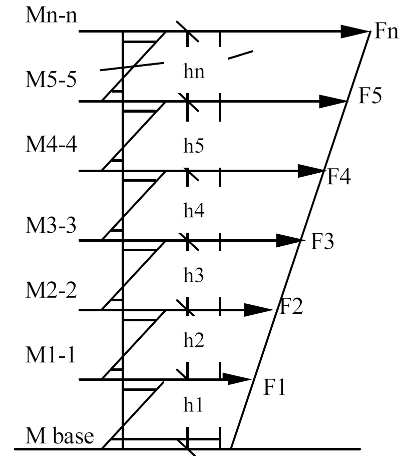
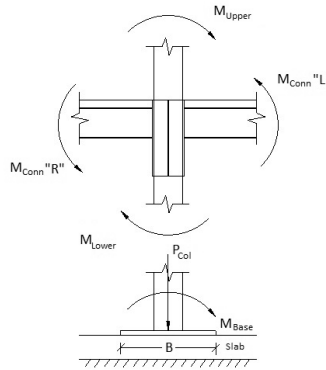

FRONT ELEVATION

Levels	h_i	f_i	Axial Load	Moment	Beam End Moment	Connector Moment
1	58	41	10,200	23,184	5,885	29,069
2	58	83	7,650	23,184	4,760	27,944
3	58	124	5,100	23,184	4,760	27,944
4	58	166	2,550	23,184	4,760	16,352

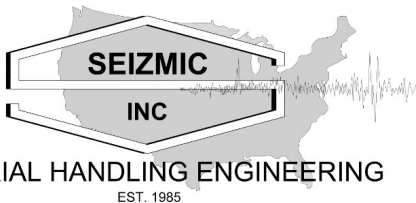

MATERIAL HANDLING ENGINEERING
EST. 1985

TEL: (909)869-0989
1130 E. CYPRESS ST, COVINA, CA 91724

PROJECT: Red Dot Corporation
FOR: Raymond West_Jack Murp
ADDRESS: 2504 E. Main Avenue
Puyallup, WA

SHEET#: 9
CALCULATED BY: ang
DATE: 4/22/2024
PN: 20240415_19

COLUMN WITH BACKER ANALYSIS: Type A (Level 1)

Analyzed per RMI, AISI 2012 (LRFD) and the 2021 IBC.

Section subject to torsional or flexural-torsion buckling (Section C4.1.2)

$$K_x \cdot L_x / R_x = 1.7 \cdot 56 / 1.26 = 75.54$$

$$K_y \cdot L_y / R_y = 1 \cdot 36 / 1.869 = 19.26$$

$$KL/R_{max} = 75.54$$

$$r_o = (r_x^2 + r_y^2 + X_o^2)^{1/2} \quad (\text{Eq. C3.1.2.1-7})$$

$$= (1.26^2 + 1.869^2 + -2.838^2)^{1/2} = 3.624 \text{ in.}$$

$$\beta = 1 - (X_o/r_o)^2 \quad (\text{Eq C4.1.2-3})$$

$$= 1 - (-2.838/3.624)^2 = 0.387$$

$$F_{e1} = \pi^2 E / (KL/r)_{max}^2 \quad (\text{Eq C4.1.1-1})$$

$$= 3.14^2 \cdot 29500 / 75.54^2 = 51.02 \text{ ksi}$$

$$F_{e2} = (1 / 2\beta) ((\sigma_{ex} + \sigma_t) - (\sigma_{ex} + \sigma_t)^2 - (4\beta\sigma_{ex}\sigma_t))^{1/2} \quad (\text{Eq C4.1.2-1})$$

$$= (1 / (2 \cdot 0.387)) ((51.02 + 88.107) - (51.02 + 88.107)^2 - (4 \cdot 0.387 \cdot 51.02 \cdot 88.107))^{1/2} = 35.893 \text{ ksi}$$

where:

$$\sigma_{ex} = \pi^2 E / (K_x L_x / R_x)^2 \quad (\text{Eq C3.1.2-11})$$

$$= 3.14^2 \cdot 29500 / 75.54^2 = 51.02 \text{ ksi}$$

$$\sigma_t = 1 / A r_o^2 (GJ + (\pi^2 E C_w) / (K_t L_t)^2) \quad (\text{Eq C3.1.2-9})$$

$$= 1 / 1.473 \cdot 3.624^2 (11300 \cdot 0.003 + (3.142 \cdot 29500 \cdot 4.773) / (0.8 \cdot 36)^2) = 88.107 \text{ ksi}$$

$$F_c = \text{Min}(F_{e1}, F_{e2}) = 35.893 \text{ ksi}$$

$$P_n = A_{eff} \cdot F_n \quad (\text{Eq C4.1-1})$$

$$\lambda_c = (F_y / F_c)^{1/2} = (55 / 35.893)^{1/2} = 1.238 \quad (\text{Eq C4.1-4})$$

Since $\lambda_c < 1.5$:

$$F_n = (0.658^{(\lambda_c^2)}) \cdot F_y = 28.962 \quad (\text{Eq C4.1-2})$$

Thus:

$$P_n = 36537 \text{ lbs}$$

$$P_a = 31057 \text{ lbs}$$

3 x 3 - .075	
SECTION PROPERTIES	
Depth	6 in.
Width	3 in.
t	0.074 in.
Radius	0.125 in.
Area	1.473 in. ²
AreaNet	1.262 in. ²
I _x	2.34 in. ⁴
S _x	1.56 in. ³
S _{xNet}	1.444 in. ³
R _x	1.26 in.
I _y	5.146 in. ⁴
S _y	1.597 in. ³
R _y	1.869 in.
J	0.003 in. ⁴
C _w	4.773 in. ⁶
J _x	2.982 in.
X _o	-2.838 in.
K _x	1.7
L _x	56 in.
K _y	1
L _y	36 in.
K _t	0.8
F _y	55 ksi
F _u	65 ksi
Q	1
G	11300 ksi
E	29500 ksi
C _{mx}	0.85
C _s	-1
C _b	1
C _{tf}	1
Phi _b	0.9
Phi _c	0.85

COLUMN WITH BACKER ANALYSIS: Type A (Level 1)

Analyzed per RMI, AISI 2012 (LRFD) and the 2021 IBC.

Lateral-torsional buckling strength [Resistance] (Section C3.1.2)

$$P_{ao} = P_{no} \phi_c = 58979 \text{ lbs}$$

Where:

$$P_{no} = A_c F_y = 1.262 \cdot 55 = 69388 \text{ lbs}$$

$$M_c = M_n = S_c F_c = S_{min} F_c \quad (\text{Eq C3.1.2.1-1})$$

$$F_c = C_b r_o A (\sigma_{cy} \sigma_t)^{1/2} / S_f = 229.49 \text{ ksi}$$

$$F_c = C_s A \sigma_{cx} (j + C_s (j^2 + r_o^2 (\sigma_c / \sigma_{cx}))^{1/2}) / (C_{TF} S_f) = 127.074 \text{ ksi} \quad (\text{Eq 3.1.2.1-4})$$

$$F_c = (C_b \pi^2 E d I_{yc}) / (S_f (K_y L_y)^2) = 4446.75 \text{ ksi} \quad (\text{Eq 3.1.2.1-10})$$

$$F_{c.min} = 127.074 \text{ ksi}$$

Since: $0.56 F_y < 2.78 F_y$

$$F_c = (10/9) F_y (1 - (10 F_y / 36 F_c)) = 53.8 \text{ ksi} \quad (\text{Eq C3.1.2.1-2})$$

Reduced $F_{c,eff} = 1 - ((1 - Q) / 2) \cdot (F_c / F_y)^2 \cdot F_c = 53.8 \text{ ksi}$

$$M_{nx} = 77687 \text{ in-lbs} \quad M_{ny} = 85931 \text{ in-lbs} \quad M_c = M_{n.min}$$

$$M_{nx} \phi_b = 69918 \text{ in-lbs} \quad M_{ny} \phi_b = 77338 \text{ in-lbs}$$

$$P_{Ex} = \pi^2 E I_x / (K_x L_x)^2 = 75173 \text{ lbs} \quad (\text{Eq C5.2.2-6})$$

$$P_{Ey} = \pi^2 E I_y / (K_y L_y)^2 = 1156155 \text{ lbs} \quad (\text{Eq C5.2.2-7})$$

$$\alpha_x = (1 - (\phi_c P / P_{Ex})) = 0.878 \quad (\text{Eq C5.2.2-4})$$

$$\alpha_y = (1 - (\phi_c P / P_{Ey})) = 0.992 \quad (\text{Eq C5.2.2-5})$$

$$P_{trans} = 24,528 \text{ lbs} \quad P_{long} = 10,094 \text{ lbs}$$

$$M_u = M_x = 23184 \text{ in-lbs} \quad (\text{Eq C5.2.2-2})$$

$$P_{u.st} = (1.2 \cdot D) + (1.4 \cdot P) = 14240 \text{ lbs}$$

$$P_{u.st} / P_a = 14240 / 31057 = 0.46 \quad \text{Static Stress} = 45\%$$

$$\text{Since: } P_i / P_a \geq 0.15$$

$$\text{Stress1} = P_i / P_a + M_x / (\phi_b M_{nx}) + M_y / (\phi_b M_{ny}) \quad (\text{Eq C5.2.2-2})$$

$$= ((10,094 / 31057) + (23184 / 69918) + (1 / 77338)) = 65\%$$

$$\text{Stress2} = P_i / P_{ao} + C_{mx} M_x / (\phi_b M_{nx} \alpha_x) + C_{my} M_y / (\phi_b M_{ny} \alpha_y) \quad (\text{Eq C5.2.2-1})$$

$$= (10,094 / 58979) + (0.85 \cdot 23184 / 69918 \cdot 0.878) + (0.85 \cdot 1 / 77338 \cdot 0.992) = 49\%$$

$$\text{Stress3} \quad P_i / P_{ao} = 24,528 / 58979 = 41\%$$

$$\text{Column Stress} = \text{Max}(\text{Stress1}, \text{Stress2}, \text{Stress3}, \text{Static}) = 65\%$$

3 x 3 - .075	
SECTION PROPERTIES	
Depth	6 in.
Width	3 in.
t	0.074 in.
Radius	0.125 in.
Area	1.473 in. ²
AreaNet	1.262 in. ²
I _x	2.34 in. ⁴
S _x	1.56 in. ³
S _{x Net}	1.444 in. ³
R _x	1.26 in.
I _y	5.146 in. ⁴
S _y	1.597 in. ³
R _y	1.869 in.
J	0.003 in. ⁴
C _w	4.773 in. ⁶
J _x	2.982 in.
X _o	-2.838 in.
K _x	1.7
L _x	56 in.
K _y	1
L _y	36 in.
K _t	0.8
F _y	55 ksi
F _u	65 ksi
Q	1
G	11300 ksi
E	29500 ksi
C _{mx}	0.85
C _s	-1
C _b	1
C _{tf}	1
Phi _b	0.9
Phi _c	0.85

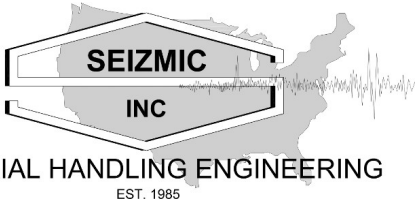

MATERIAL HANDLING ENGINEERING
EST. 1985

TEL: (909)869-0989
1130 E. CYPRESS ST, COVINA, CA 91724

PROJECT: Red Dot Corporation
FOR: Raymond West_Jack Murp
ADDRESS: 2504 E. Main Avenue
Puyallup, WA
SHEET#: 11
CALCULATED BY: ang
DATE: 4/22/2024
PN: 20240415_19

COLUMN ANALYSIS: Type A (Level 2)

Analyzed per RMI, AISI 2012 (LRFD) and the 2021 IBC.

Section subject to torsional or flexural-torsion buckling (Section C4.1.2)

$$K_x \cdot L_x / R_x = 1.5 \cdot 56 / 1.26 = 66.66$$

$$K_y \cdot L_y / R_y = 1 \cdot 36 / 1.115 = 32.29$$

$$KL/R_{max} = 66.66$$

$$r_o = (r_x^2 + r_y^2 + X_o^2)^{1/2} \quad (\text{Eq. C3.1.2.1-7})$$

$$= (1.26^2 + 1.115^2 + -2.838^2)^{1/2} = 3.299 \text{ in.}$$

$$\beta = 1 - (X_o/r_o)^2 \quad (\text{Eq C4.1.2-3})$$

$$= 1 - (-2.838/3.299)^2 = 0.26$$

$$F_{ei} = \pi^2 E / (KL/r)_{max}^2 \quad (\text{Eq C4.1.1-1})$$

$$= 3.14^2 \cdot 29500 / 66.66^2 = 65.53 \text{ ksi}$$

$$F_{e2} = (1 / 2\beta) ((\sigma_{ex} + \sigma_t) - (\sigma_{ex} + \sigma_t)^2 - (4\beta\sigma_{ex}\sigma_t))^{1/2} \quad (\text{Eq C4.1.2-1})$$

$$= (1 / (2 \cdot 0.26)) ((65.53 + 106.323) - (65.53 + 106.323)^2 - (4 \cdot 0.26 \cdot 65.53 \cdot 106.323))^{1/2} = 43.392 \text{ ksi}$$

where:

$$\sigma_{ex} = \pi^2 E / (K_x L_x / R_x)^2 \quad (\text{Eq C3.1.2-11})$$

$$= 3.14^2 \cdot 29500 / 66.66^2 = 65.53 \text{ ksi}$$

$$\sigma_t = 1 / A r_o^2 (GJ + (\pi^2 E C_w) / (K_t L_t)^2) \quad (\text{Eq C3.1.2-9})$$

$$= 1 / 0.737 \cdot 3.299^2 (11300 \cdot 0.001 + (3.142 \cdot 29500 \cdot 2.387) / (0.8 \cdot 36)^2) = 106.323 \text{ ksi}$$

$$F_c = \text{Min}(F_{ei}, F_{e2}) = 43.392 \text{ ksi}$$

$$P_n = A_{eff} \cdot F_n \quad (\text{Eq C4.1-1})$$

$$\lambda_c = (F_y / F_c)^{1/2} = (55 / 43.392)^{1/2} = 1.126 \quad (\text{Eq C4.1-4})$$

Since $\lambda_c < 1.5$:

$$F_n = (0.658^{(\lambda_c^2)}) \cdot F_y = 32.357 \quad (\text{Eq C4.1-2})$$

Thus:

$$P_n = 19144 \text{ lbs}$$

$$P_a = 16272 \text{ lbs}$$

3 x 3 - .075	
SECTION PROPERTIES	
Depth	3 in.
Width	3 in.
t	0.074 in.
Radius	0.125 in.
Area	0.737 in. ²
AreaNet	0.631 in. ²
I _x	1.17 in. ⁴
S _x	0.78 in. ³
S _{xNet}	0.722 in. ³
R _x	1.26 in.
I _y	0.916 in. ⁴
S _y	0.532 in. ³
R _y	1.115 in.
J	0.001 in. ⁴
C _w	2.387 in. ⁶
J _x	3.114 in.
X _o	-2.838 in.
K _x	1.5
L _x	56 in.
K _y	1
L _y	36 in.
K _t	0.8
F _y	55 ksi
F _u	65 ksi
Q	0.9
G	11300 ksi
E	29500 ksi
C _{mx}	0.85
C _s	-1
C _b	1
C _{tf}	1
Phi _b	0.9
Phi _c	0.85

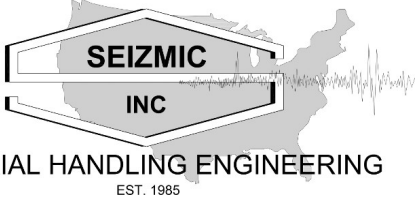

MATERIAL HANDLING ENGINEERING
EST. 1985

TEL: (909) 869-0989
1130 E. CYPRESS ST, COVINA, CA 91724

PROJECT: Red Dot Corporation
FOR: Raymond West_Jack Murp
ADDRESS: 2504 E. Main Avenue
Puyallup, WA
SHEET#: 12
CALCULATED BY: ang
DATE: 4/22/2024
PN: 20240415_19

COLUMN ANALYSIS: Type A (Level 2)

Analyzed per RMI, AISI 2012 (LRFD) and the 2021 IBC.

Lateral-torsional buckling strength [Resistance] (Section C3.1.2)

$$P_{ao} = P_{no} \phi_c = 27660 \text{ lbs}$$

Where:

$$P_{no} = A_c F_y = 0.592 \cdot 55 = 32541 \text{ lbs}$$

$$M_c = M_n = S_c F_c = S_{min} F_c \quad (\text{Eq C3.1.2.1-1})$$

$$F_c = C_b r_o A (\sigma_{cy} \sigma_t)^{1/2} / S_f = 260.084 \text{ ksi}$$

$$F_c = C_s A \sigma_{cx} (j + C_s (j^2 + r_o^2 (\sigma_c / \sigma_{cx}))^{1/2}) / (C_{TF} S_f) = 130.992 \text{ ksi} \quad (\text{Eq 3.1.2.1-4})$$

$$F_c = (C_b \Pi^2 E d I_{yc}) / (S_f (K_y L_y)^2) = 791.132 \text{ ksi} \quad (\text{Eq 3.1.2.1-10})$$

$$F_{c.min} = 130.992 \text{ ksi}$$

Since: $0.56 F_y < 2.78 F_y$

$$F_c = (10/9) F_y (1 - (10 F_y / 36 F_c)) = 54 \text{ ksi} \quad (\text{Eq C3.1.2.1-2})$$

Reduced $F_{c,eff} = 1 - ((1 - Q) / 2) \cdot (F_c / F_y)^2 \cdot F_c = 51.3 \text{ ksi}$

$$M_{nx} = 37038 \text{ in-lbs} \quad M_{ny} = 27276 \text{ in-lbs} \quad M_c = M_{n.min}$$

$$M_{nx} \phi_b = 33334 \text{ in-lbs} \quad M_{ny} \phi_b = 24548 \text{ in-lbs}$$

$$P_{Ex} = \Pi^2 E I_x / (K_x L_x)^2 = 48277 \text{ lbs} \quad (\text{Eq C5.2.2-6})$$

$$P_{Ey} = \Pi^2 E I_y / (K_y L_y)^2 = 205694 \text{ lbs} \quad (\text{Eq C5.2.2-7})$$

$$\alpha_x = (1 - (\phi_c P / P_{Ex})) = 0.857 \quad (\text{Eq C5.2.2-4})$$

$$\alpha_y = (1 - (\phi_c P / P_{Ey})) = 0.967 \quad (\text{Eq C5.2.2-5})$$

$$P_{trans} = 17,193 \text{ lbs} \quad P_{long} = 7,570 \text{ lbs}$$

$$M_u = M_x = 9605 \text{ in-lbs} \quad (\text{Eq C5.2.2-2})$$

$$P_{u.st} = (1.2 \cdot D) + (1.4 \cdot P) = 10680 \text{ lbs}$$

$$P_{u.st} / P_a = 10680 / 16272 = 0.66 \quad \text{Static Stress} = 65\%$$

$$\text{Since: } P_l / P_a \geq 0.15$$

$$\text{Stress1} = P_l / P_a + M_x / (\phi_b M_{nx}) + M_y / (\phi_b M_{ny}) \quad (\text{Eq C5.2.2-2})$$

$$= ((7,570 / 16272) + (9605 / 33334) + (1 / 24548)) = 75\%$$

$$\text{Stress2} = P_l / P_{ao} + C_{mx} M_x / (\phi_b M_{nx} \alpha_x) + C_{my} M_y / (\phi_b M_{ny} \alpha_y) \quad (\text{Eq C5.2.2-1})$$

$$= (7,570 / 27660) + (0.85 \cdot 9605 / 33334 \cdot 0.857) + (0.85 \cdot 1 / 24548 \cdot 0.967) = 55\%$$

$$\text{Stress3 } P_l / P_{ao} = 17,193 / 27660 = 62\%$$

$$\text{Column Stress} = \text{Max}(\text{Stress1, Stress2, Stress3, Static}) = 75\%$$

3 x 3 - .075	
SECTION PROPERTIES	
Depth	3 in.
Width	3 in.
t	0.074 in.
Radius	0.125 in.
Area	0.737 in. ²
AreaNet	0.631 in. ²
I _x	1.17 in. ⁴
S _x	0.78 in. ³
S _{x Net}	0.722 in. ³
R _x	1.26 in.
I _y	0.916 in. ⁴
S _y	0.532 in. ³
R _y	1.115 in.
J	0.001 in. ⁴
C _w	2.387 in. ⁶
J _x	3.114 in.
X _o	-2.838 in.
K _x	1.5
L _x	56 in.
K _y	1
L _y	36 in.
K _t	0.8
F _y	55 ksi
F _u	65 ksi
Q	0.9
G	11300 ksi
E	29500 ksi
C _{mx}	0.85
C _s	-1
C _b	1
C _{tf}	1
Phi _b	0.9
Phi _c	0.85

BEAM ANALYSIS Type A

Determine allowable bending moment per AISI

Check compression flange for local buckling (B2.1)

$$\text{Effective width } w = C - 2t - 2r = 1.625 - (2 \cdot 0.06) - (2 \cdot 0.125) = \mathbf{1.26 \text{ in.}}$$

$$w/t = 1.255 / 0.06 = \mathbf{20.99}$$

$$\lambda = (1.052 / k^{1/2}) \cdot (w/t) \cdot (F_y / E)^{1/2} = (1.052 / 2) \cdot 20.993 \cdot (55 / 29500)^{1/2} = \mathbf{0.48}$$

$\lambda \leq \mathbf{0.673}$: **Flange is fully effective.**

Check web for local buckling (B2.3)

$$f_1(\text{comp}) = F_y \cdot (y_3 / y_2) = 55 \cdot 1.99 / 2.18 = \mathbf{50.34 \text{ ksi}}$$

$$f_2(\text{tension}) = F_y \cdot (y_1 / y_2) = 55 \cdot 1.76 / 2.18 = \mathbf{44.43 \text{ ksi}}$$

$$\Psi = -(f_2 / f_1) = -(44.43 / 50.34) = \mathbf{-0.88}$$

$$\text{Buckling coefficient } k = 4 + 2 \cdot (1 - \Psi)^3 + 2 \cdot (1 - \Psi)$$

$$= 4 + 2(1 - \mathbf{-0.88})^3 + 2(1 - \mathbf{-0.88}) = \mathbf{21.11}$$

$$\text{Flat Depth } w = y_1 + y_3 = 1.76 + 1.99 = \mathbf{3.755}$$

$$w/t = 3.755 / 0.06 = \mathbf{62.8} \quad w/t < \mathbf{200}$$
: **OK**

$$\lambda = (1.052 / k^{1/2}) \cdot (w/t) \cdot (f_1 / E)^{1/2} = (1.052 / 2) \cdot 62.799 \cdot (50.34 / 29500)^{1/2} = \mathbf{0.59}$$

$$b_1 = w \cdot (3 - \Psi) = 4 \cdot (3 - \mathbf{-0.88}) = \mathbf{14.58}$$

$$b_2 = w/2 = \mathbf{1.88}$$

$$b_1 + b_2 = 14.58 + 1.88 = \mathbf{16.46} \quad \text{Web is fully effective}$$

Determine effect of cold working on steel yield point (FYA) per section A7.2

$$\text{Corner cross-sectional area } L_c = (\pi / 2) \cdot (r + t / 2)$$

$$= (\pi / 2) \cdot (0.125 + 0.06 / 2) = \mathbf{0.243}$$

$$L_f = \text{effective width} = \mathbf{1.255}$$

$$C = 2 \cdot L_c / L_f + 2 \cdot L_c = 2 \cdot 0.243 / 1.255 + 2 \cdot L_c = \mathbf{0.2793}$$

$$m = 0.192 \cdot (F_u / F_y) - 0.068 = 0.192 \cdot (70 / 55) - 0.068 = \mathbf{0.1764}$$

$$B_c = 3.69 \cdot (F_u / F_y) - 0.819 \cdot (F_u / F_y)^2 - 1.79$$

$$= 3.69 \cdot (70 / 55) - 0.819 \cdot (70 / 55)^2 - 1.79 = \mathbf{1.58}$$

$$F_u / F_y = 70 / 55 = 1 \quad \geq \mathbf{1.2} = \mathbf{OK}$$

$$r/t = 0.125 / 0.06 = \mathbf{2.09} \quad \leq \mathbf{7} = \mathbf{OK}$$

$$F_{yc} = B_c \cdot F_y / (r/t)^m = 1.58 \cdot 55 / (2.09)^m = \mathbf{76}$$

$$F_{ya-top} = C \cdot F_{yc} + (1 - C) \cdot F_y = 0.279 \cdot 76 + (1 - 0.279) \cdot 55 = \mathbf{61}$$

$$F_{ya-bottom} = F_{ya-top} \cdot Y_{cg} / (A - Y_{cg}) = 61 \cdot 1.95 / (4.125 - 1.95) = \mathbf{54}$$

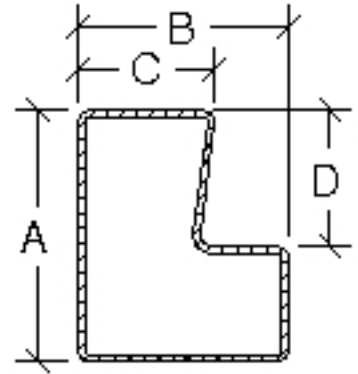

4.13 x 2.5 - .060

Top flange width C =	1.625 in.
Bottom width B =	2.5 in.
Web depth A =	4.125 in.
Beam thickness t =	0.06 in.
Radius r =	0.125 in.
Fy =	55
Fu =	70
Y1 =	1.76
Y2 =	2.18
Y3 =	1.99
Ycg =	1.95
Ix =	1.59
Sx =	0.73
E =	29500
FBeam F =	300
Beam Length L =	96

BEAM ANALYSIS Type A

Check Allowable Tension Stress for Bottom Flange

$$L_{flange-bot} = B - (2 \cdot r) - (2 \cdot t) = 2.5 - (2 \cdot 0.125) - (2 \cdot 0.06) = \mathbf{2.13}$$

$$C_{bottom} = 2 \cdot L_c / (L_{flange-bot} + 2 \cdot L_c) = 2 \cdot 0.243 / (2.13 + 2 \cdot 0.243) = \mathbf{0.186}$$

$$F_{y-bottom} = C_{bottom} \cdot F_{yc} + (1 - C_{bottom}) \cdot F_y = 0.186 \cdot 76 + (1 - 0.186) \cdot 55 = \mathbf{58.96}$$

$$F_{ya} = F_{ya-top} = \mathbf{60.95 \text{ ksi}}$$

Determine Allowable Capacity For Beam Pair (Per Section 5.2 of the RMI, PT II)

Check Bending Capacity

$$M_{Center} = \phi \cdot M_n = W \cdot L \cdot \Omega \cdot R_m / 8$$

$$\Omega = \text{LRFD Load Factor} = (1.2 \cdot DL + 1.4 \cdot PL + 1.4 \cdot 0.125 \cdot PL) / PL$$

For DL = 2% of PL:

$$\Omega = 1.2 \cdot 0.02 + 1.4 + 1.4 \cdot 0.125 = \mathbf{1.6}$$

$$R_m = 1 - ((2 \cdot F \cdot L) / (6 \cdot E \cdot I_x + 3 \cdot F \cdot L))$$

$$= 1 - ((2 \cdot 300 \cdot 96) / (6 \cdot 29500 \cdot 1.59 + 3 \cdot 300 \cdot 96)) = \mathbf{0.84}$$

$$\phi \cdot M_n = \phi \cdot F_{ya} \cdot S_x = \mathbf{42.22 \text{ in-kip}}$$

$$W = \phi \cdot M_n \cdot 8 \cdot (\# \text{ of Beams}) / (L \cdot R_m \cdot \Omega) = (42.22 \cdot 8 \cdot 2) / (96 \cdot 0.84 \cdot 1.6)$$

$$= \mathbf{5218 \text{ lbs/pair}}$$

Check Deflection Capacity

$$\Delta_{max} = \Delta_{ss} \cdot R_d$$

$$\Delta_{max} = L / 180$$

$$R_d = 1 - (4 \cdot F \cdot L) / (5 \cdot F \cdot L + 10 \cdot E \cdot I_x)$$

$$= 1 - (4 \cdot 300 \cdot 96) / (5 \cdot 300 \cdot 96 + 10 \cdot 29500 \cdot 1.59) = \mathbf{0.81}$$

$$\Delta_{ss} = (5 \cdot W \cdot L^3) / (384 \cdot E \cdot I_x)$$

$$L / 180 = (5 \cdot W \cdot L^3 \cdot R_d) / (384 \cdot E \cdot I_x \cdot (\# \text{ of Beams}))$$

$$W = (384 \cdot E \cdot I_x \cdot 2) / (180 \cdot 5 \cdot L^2 \cdot R_d)$$

$$= (384 \cdot 29500 \cdot 1.59 \cdot 2) / (180 \cdot 5 \cdot 96^2 \cdot 0.81) \cdot 1000 = \mathbf{5346 \text{ lbs/pair}}$$

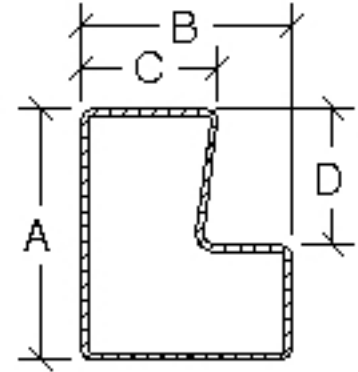

4.13 x 2.5 - .060

Top flange width C =	1.625 in.
Bottom width B =	2.5 in.
Web depth A =	4.125 in.
Beam thickness t =	0.06 in.
Radius r =	0.125 in.
Fy =	55
Fu =	70
Y1 =	1.76
Y2 =	2.18
Y3 =	1.99
Ycg =	1.95
Ix =	1.59
Sx =	0.73
E =	29500
FBeam F =	300
Beam Length L =	96

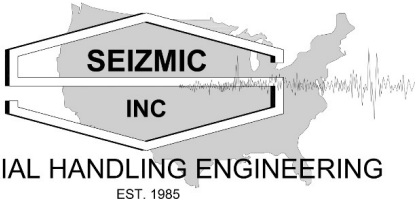

MATERIAL HANDLING ENGINEERING
EST. 1985

TEL: (909) 869-0989
1130 E. CYPRESS ST, COVINA, CA 91724

PROJECT: Red Dot Corporation
FOR: Raymond West_Jack Murp
ADDRESS: 2504 E. Main Avenue
 Puyallup, WA
SHEET#: 15
CALCULATED BY: ang
DATE: 4/22/2024
PN: 20240415_19

Allowable and Actual Bending Moment at Each Level

$$M_{static} = Wl^2 / 8 \quad M_{allow,static} = W_{allow,static} \cdot l^2 / 8 \quad M_{seismic} = M_{conn} \quad M_{allow,seismic} = S_x \cdot F_b$$

Level	M_{static}	$M_{allow,static}$	$M_{seismic}$	$M_{allow,seismic}$	Result
1	30,576	32,748	11,140	32,748	Pass
2	30,576	31,308	5,982	31,308	Pass
3	30,576	31,308	3,581	31,308	Pass
4	30,576	31,308	2,380	31,308	Pass

Beam to Column Analysis: Type A

1. Shear Strength of Pin

Pin Diameter = **0.35 in.**

$$F_n = F_{nv} = \mathbf{54000 \text{ psi}} \quad \text{AISI Table E3.4-1}$$

$$A_b = d^2 \cdot \pi / 4 = \mathbf{0.1 \text{ in.}}$$

$$P_n = A_b \cdot F_n = \mathbf{5195.41 \text{ lbs}} \quad \text{AISI Table E3.4-1}$$

$$P_{\text{Shear}} = \phi P_n = 0.75 \cdot P_n = \mathbf{3896 \text{ lbs}}$$

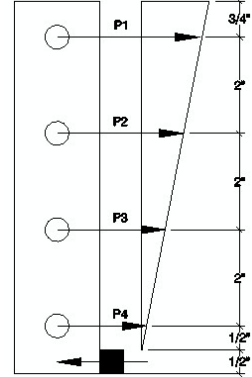

2. Bearing Strength of Pin

Column Thickness $t_c = \mathbf{0.07 \text{ in.}}$

Since $d / t_c < 10 \quad C = 3$

$$m_f = \mathbf{1.0}$$

$$F_u = \mathbf{65000 \text{ psi}}$$

$$P_n = C \cdot m_f \cdot d \cdot t_c \cdot F_u = \mathbf{5050.5 \text{ lbs}} \quad \text{AISI E3.3.1 -1}$$

$$P_{\text{Bearing}} = \phi P_n = 0.75 \cdot 5050.5 = \mathbf{3787 \text{ lbs}}$$

3. Moment Strength of Bracket

Edge Dist. = **1 in.**

$$T_{\text{Clip}} = \mathbf{0.179 \text{ in.}}$$

$$S_{\text{Clip}} = \mathbf{0.127 \text{ in.}^3}$$

$$M_n = S_c \cdot F_y = \mathbf{6985 \text{ in-lbs}} \quad \text{AISI C3.1.1 -1}$$

$$M_{\text{Strength}} = \phi M_n = 0.9 \cdot M_n = 0.9 \cdot S_{\text{Clip}} \cdot F_y = \mathbf{6286.5 \text{ in-lbs}}$$

$$C = \mathbf{2.15}$$

$$d = \text{Edge Dist.} / 2 = \mathbf{0.5 \text{ in.}}$$

$$M_{\text{Strength}} = c \cdot d \cdot P_{\text{Clip}}$$

$$P_{\text{Clip}} = M_{\text{Strength}} / (c \cdot d) = \mathbf{5837 \text{ lbs}}$$

Minimum Value of P1 Governs

$$P_1 = \text{Min}(P_{\text{Shear}}, P_{\text{Bearing}}, P_{\text{Clip}}) = \mathbf{3787 \text{ lbs}}$$

$$M_{\text{Conn-Allow}} = (P_1 \cdot 6.5) + (P_1 \cdot (4.5 / 6.5) \cdot 4.5) + (P_1 \cdot (2.5 / 6.5) \cdot 2.5) + (P_1 \cdot (0.5 / 6.5) \cdot 0.5) = \mathbf{40200.46 \text{ in-lbs}}$$

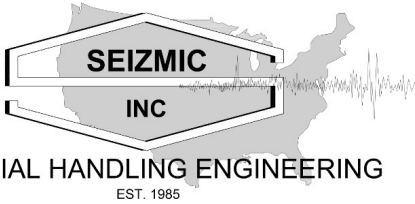

MATERIAL HANDLING ENGINEERING
EST. 1985

TEL: (909)869-0989
1130 E. CYPRESS ST, COVINA, CA 91724

PROJECT: Red Dot Corporation
FOR: Raymond West_Jack Murp
ADDRESS: 2504 E. Main Avenue
Puyallup, WA

SHEET#: 17
CALCULATED BY: ang
DATE: 4/22/2024
PN: 20240415_19

BRACE ANALYSIS Type A (Panel 5)

Analyzed per RMI, AISI 2012 (LRFD) and the 2021 IBC.

Section subject to torsional or flexural-torsion buckling (Section C4.1.2)

$$K_x \cdot L_x / R_x = 1 \cdot 60 / 0.614 = 97.66$$

$$K_y \cdot L_y / R_y = 1 \cdot 60 / 0.404 = 148.63$$

$$KL/R_{max} = 148.63$$

$$r_o = (r_x^2 + r_y^2 + X_o^2)^{1/2} \quad (\text{Eq. C3.1.2.1-7})$$

$$= (0.614^2 + 0.404^2 + (-0.917)^2)^{1/2} = 1.175 \text{ in.}$$

$$\beta = 1 - (X_o/r_o)^2 \quad (\text{Eq C4.1.2-3})$$

$$= 1 - (-0.917/1.175)^2 = 0.391$$

$$F_{ei} = \pi^2 E / (KL/r)_{max}^2 \quad (\text{Eq C4.1.1-1})$$

$$= 3.14^2 \cdot 29500 / 148.63^2 = 13.181 \text{ ksi}$$

$$F_{e2} = (1/2\beta)((\sigma_{ex} + \sigma_t) - (\sigma_{ex} + \sigma_t)^2 - (4\beta\sigma_{ex}\sigma_t))^{1/2} \quad (\text{Eq C4.1.2-1})$$

$$= (1/(2 \cdot 0.391))((30.53 + 17.818) - (30.53 + 17.818)^2 - (4 \cdot 0.391 \cdot 30.53 \cdot 17.818))^{1/2} = 12.519 \text{ ksi}$$

where:

$$\sigma_{ex} = \pi^2 E / (K_x L_x / R_x)^2 \quad (\text{Eq C3.1.2-11})$$

$$= 3.14^2 \cdot 29500 / 97.66^2 = 30.53 \text{ ksi}$$

$$\sigma_t = 1 / A r_o^2 (GJ + (\pi^2 E C_w) / (K_t L_t)^2) \quad (\text{Eq C3.1.2-9})$$

$$= 1 / 0.279 \cdot 1.175^2 (11300 \cdot 0.001 + (3.142 \cdot 29500 \cdot 0.015) / (0.8 \cdot 60)^2) = 17.818 \text{ ksi}$$

$$F_c = \text{Min}(F_{ei}, F_{e2}) = 12.519 \text{ ksi}$$

$$P_n = A_{eff} \cdot F_n \quad (\text{Eq C4.1-1})$$

$$\lambda_c = (F_y / F_c)^{1/2} = (36 / 12.519)^{1/2} = 1.696 \quad (\text{Eq C4.1-4})$$

Since $\lambda_c \geq 1.5$:

$$F_n = (0.877 / \lambda_c^2) \cdot F_y = 10.979 \quad (\text{Eq C4.1-3})$$

Thus:

$$P_n = 3064 \text{ lbs}$$

$$P_a = 2604 \text{ lbs}$$

1.5 x 1.25 - .075	
SECTION PROPERTIES	
Depth	1.5 in.
Width	1.25 in.
t	0.075 in.
Radius	0.112 in.
Area	0.279 in. ²
AreaNet	0.279 in. ²
I _x	0.105 in. ⁴
S _x	0.141 in. ³
S _{xNet}	0.141 in. ³
R _x	0.614 in.
I _y	0.046 in. ⁴
S _y	0.056 in. ³
R _y	0.404 in.
J	0.001 in. ⁴
C _w	0.015 in. ⁶
J _x	1.183 in.
X _o	-0.917 in.
K _x	1
L _x	60 in.
K _y	1
L _y	60 in.
K _t	0.8
F _y	36 ksi
F _u	42 ksi
Q	1
G	11300 ksi
E	29500 ksi
C _{mx}	0.85
C _s	-1
C _b	1
C _{tf}	1
Phi _b	0.9
Phi _c	0.85

BRACE ANALYSIS Type A (Panel 5)

Analyzed per RMI, AISI 2012 (LRFD) and the 2021 IBC.

Lateral-torsional buckling strength [Resistance] (Section C3.1.2)

$$P_{ao} = P_{no} \phi_c = 8540 \text{ lbs}$$

Where:

$$P_{no} = A_c F_y = 0.279 \cdot 36 = 10047 \text{ lbs}$$

$$M_c = M_n = S_c F_c = S_{min} F_c \quad (\text{Eq C3.1.2.1-1})$$

$$F_c = C_b r_o A (\sigma_{cy} \sigma_t)^{1/2} / S_f = 54.46 \text{ ksi}$$

$$F_c = C_s A \sigma_{cx} (j + C_s (j^2 + r_o^2 (\sigma_c / \sigma_{cx}))^{1/2}) / (C_{TF} S_f) = 18.331 \text{ ksi} \quad (\text{Eq 3.1.2.1-4})$$

$$F_c = (C_b \Pi^2 E d I_{yc}) / (S_f (K_y L_y)^2) = 39.287 \text{ ksi} \quad (\text{Eq 3.1.2.1-10})$$

$$F_{c,min} = 18.331 \text{ ksi}$$

Since: $F_c \leq 0.56 F_y$

$$F_c = F_c = 18.331 \text{ ksi} \quad (\text{Eq C3.1.2.1-3})$$

Reduced $F_{c,eff} = 1 - ((1 - Q) / 2) \cdot (F_c / F_y)^2 \cdot F_c = 18.3 \text{ ksi}$

$$M_{nx} = 2571 \text{ in-lbs} \quad M_{ny} = 1019 \text{ in-lbs} \quad M_c = M_{n,min}$$

$$M_{nx} \phi_b = 2314 \text{ in-lbs} \quad M_{ny} \phi_b = 917 \text{ in-lbs}$$

$$P_{Ex} = \Pi^2 E I_x / (K_x L_x)^2 = 8524 \text{ lbs} \quad (\text{Eq C5.2.2-6})$$

$$P_{Ey} = \Pi^2 E I_y / (K_y L_y)^2 = 3679 \text{ lbs} \quad (\text{Eq C5.2.2-7})$$

$$P_a = 2604 \text{ lbs}$$

$$V_{Trans} = 871 \text{ lbs}$$

$$V_{Trans(new)} = 871 \cdot 1.3 = 1132 \text{ lbs}$$

$$L_{Diag} = ((L - 6)^2 + (D - 2B)^2)^{1/2} = 60 \text{ in.}$$

$$V_{Diag} = (V_{Trans} \cdot L_{Diag}) / D = 1887 \text{ lbs}$$

$$\text{Brace Stress} = V_{Diag} / P_a = 72\%$$

1.5 x 1.25 - .075	
SECTION PROPERTIES	
Depth	1.5 in.
Width	1.25 in.
t	0.075 in.
Radius	0.112 in.
Area	0.279 in. ²
AreaNet	0.279 in. ²
I _x	0.105 in. ⁴
S _x	0.141 in. ³
S _{x Net}	0.141 in. ³
R _x	0.614 in.
I _y	0.046 in. ⁴
S _y	0.056 in. ³
R _y	0.404 in.
J	0.001 in. ⁴
C _w	0.015 in. ⁶
J _x	1.183 in.
X _o	-0.917 in.
K _x	1
L _x	60 in.
K _y	1
L _y	60 in.
K _t	0.8
F _y	36 ksi
F _u	42 ksi
Q	1
G	11300 ksi
E	29500 ksi
C _{mx}	0.85
C _s	-1
C _b	1
C _{tf}	1
Phi _b	0.9
Phi _c	0.85

**POST-INSTALLED ANCHOR ANALYSIS PER ACI 318-19(ACI 318-14), CHAPTER 17 Configuration 1
Type A**

Assumed cracked concrete application

Anchor Type	0.625" dia., 4 hef, 6" min, slab		
ICC Report Number	ESR-4266	$1.5 \cdot h_{ef}$	= 6 in.
Slab Thickness (h)	= 7 in.	$C_{a1} = 12$	use $C_{a1,adj} = 6$ in.
Min. Slab Thickness (h)	= 6 in.	$C_{a2} = 12$	use $C_{a2,adj} = 6$ in.
Concrete Strength (f_c)	= 4000 psi		
Diameter (d_a)	= 0.625 in.	$3 \cdot h_{ef}$	= 12 in.
Nominal Embedment (h_{nom})	= 4.5 in.		
Effective Embedment (h_{ef})	= 4 in.	$S_1 = 6$ in.	Use $S_{1,adj} = 6$ in.
Number of Anchors (n)	= 4	$S_2 = 6$ in.	Use $S_{2,adj} = 6$ in.
$e'N$	= 0		
$e'V$	= 0		

From ICC ESR Report

A_{sc}	= 0.164 sq.in.
f_{uta}	= 106700 psi
S_{min}	= 2.25 in.
C_{min}	= 2.75 in.
C_{ac}	= 9 in.
$N_{p,cr}$	= 9999 lbs

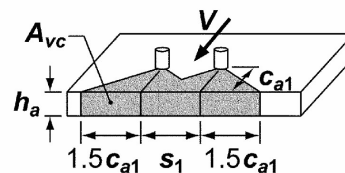
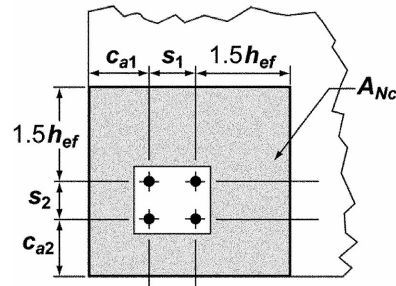

	$\phi_{Seismic}$	Adj. Strength
Tension Capacity = 3145 lbs	0.75	2359 lbs
Shear Capacity = 6665 lbs	0.75	4999 lbs

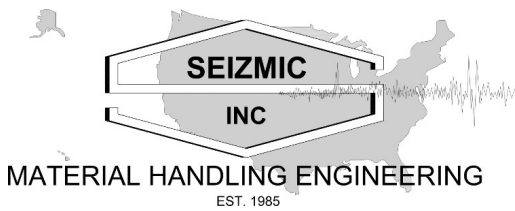

MATERIAL HANDLING ENGINEERING
EST. 1985

TEL: (909) 869-0989
1130 E. CYPRESS ST, COVINA, CA 91724

PROJECT: Red Dot Corporation
FOR: Raymond West_Jack Murp
ADDRESS: 2504 E. Main Avenue
Puyallup, WA
SHEET#: 20
CALCULATED BY: ang
DATE: 4/22/2024
PN: 20240415_19

ANCHOR ANALYSIS - TENSION STRENGTH Configuration 1 Type A

Steel Strength	17.4.1
$\phi = 0.75$	17.3.3.a i
$\phi N_{sa} = \phi n A_{sc} f_{uta} = 0.75 \cdot 4 \cdot 0.164 \cdot 106700 = 52,496 \text{ lbs}$	17.4.1.2
Concrete Breakout Strength ϕN_{cbg}	17.4.2
$\phi = 0.65$	17.3.3 c ii Category 1-B
$A_{Nc} = (C_{a1,adj} + S_{1,adj} + 1.5h_{cf}) \cdot (C_{a2,adj} + S_{2,adj} + 1.5h_{cf}) = 324 \text{ sq.in.}$	
$A_{Nco} = 9h_{cf}^2 = 144 \text{ sq.in.}$	
Check if $A_{Nco} \geq A_{Nc}$ $A_{Nc}/A_{Nco} = 2.25$	
$\Psi_{cc,N} = 1$	17.4.2.4
$\Psi_{cd,N} = 1$	17.4.2.5
$\Psi_{C,N} = 1$	17.4.2.6
$K_c = 17$	
$\lambda_a = 1$	
$N_b = K_c \lambda_a (f_c)^{0.5} (h_{cf})^{1.5} = 8601 \text{ lbs}$	17.4.2.2 d
$\Psi_{cp,N} = 1$	17.4.2.7
$\phi N_{cbg} = \phi (A_{Nc}/A_{Nco}) (\Psi_{cc,N}) (\Psi_{cd,N}) (\Psi_{C,N}) (\Psi_{cp,N}) (N_b)$	17.4.2.1
$0.65 \cdot (324/144) \cdot 1 \cdot 1 \cdot 1 \cdot 1 \cdot 8601 = 12,579 \text{ lbs}$	
Pullout Strength ϕN_{pn}	17.4.3
$\phi = 0.65$	17.3.3 c ii Category 1-B
$\Psi_{cp} = 1$	17.4.3.6
$\phi N_{pn} = \phi \Psi_{cp} N_{p,cr} (f_c/2500)^{0.5} = 32,884 \text{ lbs}$	17.4.3.1
Steel Strength (ϕN_{sa}) = 52,496 lbs	
Embedment Strength - Concrete Breakout Strength (ϕN_{cbg}) = 12,579 lbs	
Embedment Strength - Pullout Strength (ϕN_{pn}) = 32,884 lbs	

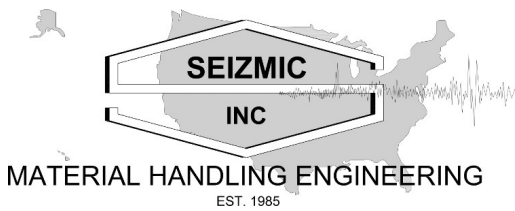

MATERIAL HANDLING ENGINEERING
EST. 1985

TEL: (909) 869-0989
1130 E. CYPRESS ST, COVINA, CA 91724

PROJECT: Red Dot Corporation
FOR: Raymond West_Jack Murp
ADDRESS: 2504 E. Main Avenue
Puyallup, WA
SHEET#: 21
CALCULATED BY: ang
DATE: 4/22/2024
PN: 20240415_19

ANCHOR ANALYSIS - SHEAR STRENGTH Configuration 1 Type A

Steel Strength ϕV_{sa} $V_{sa} = 10,255$ / Anchor -- per report	17.5.1
$\phi = 0.65$	17.3.3. Condition a ii
$\phi V_{sa} = \phi n \cdot V_{sa} = 0.65 \cdot 4 \cdot 10,255 = 26,663$ lbs	17.5.1.2a
Concrete Breakout Strength ϕV_{cbg}	17.5.2
$\phi = 0.7$	17.3.3 ci-B
$A_{Vc} = (1.5C_{a1} + S_{l,adj} + 1.5C_{a1})h_a = 294$ sq.in.	
$A_{Vco} = 3C_{a1}h_a = 252$ sq.in.	
Check if $A_{Vco} \geq A_{Vc}$ $A_{Vc}/A_{Vco} = 1.167$	
$\Psi_{cc,V} = 1$	17.5.2.5
$\Psi_{cd,V} = 0.9$	17.5.2.6
$\Psi_{C,V} = 1$	17.5.2.7
$\Psi_{h,V} = 1.604$	17.5.2.8
$d_a = 0.625$ in.	17.5.2.2
$L_c = 1.25$ in.	17.2.6 d
$\lambda_a = 1$	
The smaller of $7(L_c / d_a)^{0.2}(d_a)^{0.5}\lambda_a(f_c)^{0.5}ca1^{1.5}$ and $9\lambda_a(f_c)^{0.5}ca1^{1.5} = 16,713$ lbs	17.5.2.2 a, 17.5.2.2 b
$\phi V_{cbg} = \phi(A_{Vc}/A_{Vco})(\Psi_{cc,V})(\Psi_{cd,V})(\Psi_{C,V})(\Psi_{h,V})(V_b)$	17.5.2.1
$0.7 \cdot (294/252) \cdot 1 \cdot 0.9 \cdot 1 \cdot 1.604 \cdot 16,713 = 39,396$ lbs	
Pryout Strength ϕV_{cpg}	17.5.3
$\phi = 0.7$	17.3.3 Ci-B
$K_{cp} = 2$	17.5.3.1
$N_{cbg} = 19,352$ lbs	
$\phi V_{cpg} = \phi K_{cp} N_{cbg} = 0.7 \cdot 2 \cdot 19,352 = 27,093$ lbs	
Steel Strength (ϕV_{sa}) = 26,663 lbs	
Embedment Strength - Concrete Breakout Strength (ϕV_{cbg}) = 39,396 lbs	
Embedment Strength - Pryout Strength (ϕV_{cpg}) = 27,093 lbs	

OVERTURNING ANALYSIS Configuration1 Type A

Per RMI Sec 2.6.9 and ASCE7-16. Sec 15.5.3.6. Weight of rack with all levels loaded to 67% capacity, & with only top level loaded

FULLY LOADED

$$W_{pl} = 20,000 \text{ lbs} \quad W_{dl} = 400 \text{ lbs}$$

$$W_{pl} \cdot 67\% = 20,000 \cdot 0.67 = 13,400 \text{ lbs}$$

$$V_{Trans} = (1 \cdot 0.2525 \cdot 1 \cdot ((0.67 \cdot 13,400) + 400)) = 2,367 \text{ lbs}$$

$$M_{ovt} = V_{Trans} \cdot Ht = 2,367 \cdot 200 = 473,400 \text{ in-lbs}$$

$$M_{st} = ((W_{pl} \cdot 0.67) + W_{dl}) \cdot d \cdot \text{Factor}$$

$$= ((20,000 \cdot 0.67) + 400) \cdot 42 \cdot 0.5 = 289,800 \text{ in-lbs}$$

$$P_{uplift} = 1 \cdot (M_{ovt} - M_{st}) / d = (473,400 - 289,800) / 42 = 4,371 \text{ lbs}$$

$$P_{MaxDown} = 1 \cdot (M_{ovt} + M_{st}) / d = (473,400 + 289,800) / 42 = 18,171 \text{ lbs}$$

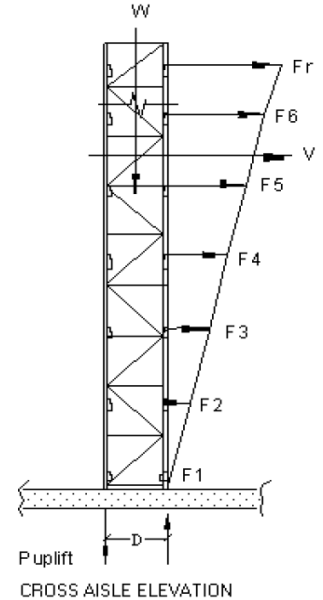

TOP SHELF LOADED

$$\text{Shear} = 1,363 \text{ lbs}$$

$$M_{ovt} = V_{Top} \cdot Ht = 1,363 \cdot (232 + ((58 - 10) / 2)) = 348,928 \text{ in-lbs}$$

$$M_{st} = (1 + W_{dl}) \cdot d = (5,000 + 400) \cdot (42 \cdot 0.5) = 113,400 \text{ in-lbs}$$

$$P_{uplift} = 1 \cdot (M_{ovt} - M_{st}) / d = (348,928 - 113,400) / 42 = 5,607 \text{ lbs}$$

ANCHORS

No. of Anchors (#Anchors): 4

Pull Out Capacity per Anchor (T_{Anchor}): 2,359 lbs

Shear Capacity per Anchor: 4,999 lbs

COMBINED STRESS

$$\text{Fully Loaded} = ((4,371 / 4) / 2,359) + ((2,367 / 8) / 4,999) = 0.522$$

$$\text{Top Shelf Loaded} = ((5,607 / 4) / 2,359) + ((1,363 / 8) / 4,999) = 0.628$$

$$\text{Seismic UpLift Critical (LC\#7B)} = (7,314 / 4) / 2,359 = 0.775$$

Base Plate Analysis: Type A

The base plate will be analyzed with the rectangular stress resulting from the vertical load P, combined with the triangular stresses resulting from the moment Mb (if any). Three criteria are used in determining Mb:

1. Moment capacity of the base plate
2. Moment capacity of the anchor bolts
3. $V_{col} \cdot h/2$ (full fixity)

Mb is the smallest value obtained from these three criteria.

$$F_y = 36000 \text{ psi}$$

$$P_{col} = 24528 \text{ lbs}$$

$$M_{Base} = 0 \text{ in-lbs}$$

$$P/A = P_{col} / (D \cdot B) = 24528 / (8 \cdot 8) = 383 \text{ psi}$$

$$f_b = M_{Base} / (D \cdot B^2 / 6) = 0 / (8 \cdot 8^2 / 6) = 0 \text{ psi}$$

$$f_{b2} = f_b \cdot (2 \cdot b_1 / B) = 0 \cdot (2 \cdot 2.5 / 8) = 0 \text{ psi}$$

$$f_{b1} = f_b - f_{b2} = 0 - 0 = 0 \text{ psi}$$

$$M_b = wb_1^2 / 2 = (b_1^2 / 2) \cdot (f_a + f_{b1} + 0.67 \cdot f_{b2})$$

$$= (2.5^2 / 2) \cdot (383 + 0 + 0.67 \cdot 0) = 1197.66 \text{ in-lbs}$$

$$S_{Base} = (B \cdot t^2) / 6 = 0.19 \text{ sq.in.}$$

$$F_{Base} = 0.9 \cdot F_y = 32,400 \text{ psi}$$

$$f_b / F_b = M_b / (S_{Base} \cdot F_{Base}) = 1197.66 / (0.19 \cdot 32,400) = 0.2$$

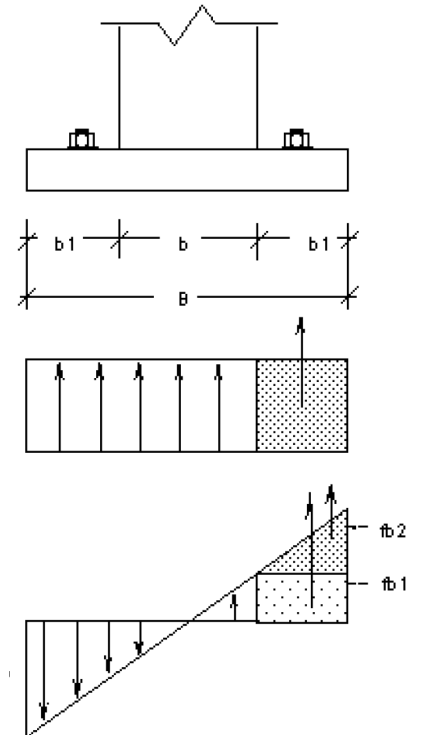
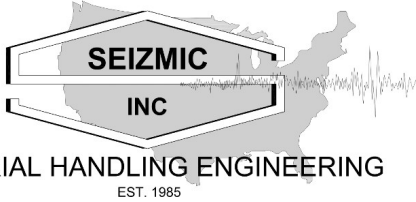

Plate width B =	8 in.
Plate depth D =	8 in.
Plate thickness t =	0.38 in.
Column width b =	3 in.
Column depth d =	3 in.
b1 =	2.5 in.



MATERIAL HANDLING ENGINEERING
EST. 1985

TEL: (909) 869-0989
1130 E. CYPRESS ST, COVINA, CA 91724

PROJECT: Red Dot Corporation
FOR: Raymond West_Jack Murp
ADDRESS: 2504 E. Main Avenue
Puyallup, WA

SHEET#: 24
CALCULATED BY: ang
DATE: 4/22/2024
PN: 20240415_19

Equation for Maximum Considered Earthquake Base Rotation

Per RMI 2012 Commentary 2.6.4

$$\alpha_s = \frac{\sum_{i=1}^{N_L} W_{pi} h_{pi} \left(\frac{k_c + k_{be}}{k_c k_{be}} \right)}{(N_c + N_b \left(\frac{k_b k_{ce}}{k_c k_{be}} \right)) \left(\frac{k_c + k_{be}}{k_b + k_{ce}} \right)}$$

α_s - the first iteration of the second order amplification term computed using W_{pi} from section 2.6.4 of the Commentary

Where:

W_{pi} = the weight of the ith pallet supported by the storage rack

h_{pi} = the elevation of the center of gravity of the ith pallet with respect to the base of the storage rack

N_L = the number of loaded levels

k_c = the rotational stiffness of the connector

k_{be} = the flexural rotational stiffness of the beam-end

k_b = the rotational stiffness of the base plate

k_{ce} = the flexural rotational stiffness of the base upright-end

N_c = the number of beam-to-upright connections

N_b = the number of base plate connections

$$k_{be} = \frac{6EI_b}{L} \quad k_{ce} = \frac{4EI_c}{H} \quad k_b = \frac{EI_c}{H}$$

L = the clear span of the beams

H = the clear height of the upright

I_b = the moment of inertia about the bending axis of each beam

I_c = the moment of inertia of each base upright

E = the Young's modulus of the beams

$\alpha_s = 1.54$

Per RMI 2012 7.1.3

$$\theta_b = \frac{C_d(1+\alpha_s)M_b}{k_b}$$

C_d = the deflection amplification factor per section 2.6.6
 M_b = the base moment from analysis
 $\theta_b = 0.62$

Per RMI 2012 2.6.6,

in unbraced direction, seismic separation for rack structure is $0.05 h_{total}$. Therefore

$\tan \theta_{max} = 0.5$ $\theta_{max} = 2.862 \text{ rad}$ θ_b ok

Maximum moment in base plate

M_{max} = if one anchor, then 0 OR (# of anchors / 2) * anchor pull out capacity * spacing of anchor(Sx)

$M_{max} = 28,308 \text{ kip-in} \geq M_b$ OK

# of levels	4	
min. # of bays	3	
N_c	48	
N_b	8	
k_c	400 kip-in/rad	
k_{be}	2930 kip-in/rad	
k_b	148 kip-in/rad	
k_{ce}	595 kip-in/rad	
I_b	1.59 in ⁴	
L	96 in	
I_c	1.17 in ⁴	
H	232 in	
E	29500 ksi	
Level	h_{pi}	W_{pi}
1	84 in	5 kip
2	142 in	5 kip
3	200 in	5 kip
4	259 in	5 kip

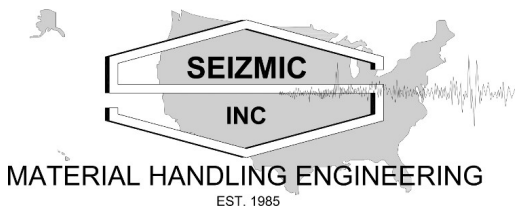

MATERIAL HANDLING ENGINEERING
EST. 1985

TEL: (909) 869-0989
1130 E. CYPRESS ST, COVINA, CA 91724

PROJECT: Red Dot Corporation
FOR: Raymond West_Jack Murp
ADDRESS: 2504 E. Main Avenue
Puyallup, WA
SHEET#: 25
CALCULATED BY: ang
DATE: 4/22/2024
PN: 20240415_19

SLAB AND SOIL ANALYSIS (LRFD)

Slab/Soil analysis based on Empirical Method - FEMA 460 Appendix D

$$P_{max} = \text{Gravity_Load (see Basic Load Combinations)} = 24,528 \text{ lbs}$$

$$f'_t = 7.5 \cdot (f'_c)^{1/2} = 474 \text{ psi}$$

$$d, req'd = (P_{max} / (\phi \cdot 1.72 \cdot ((K_s \cdot r_1 / E_c) \cdot 10^4 + 3.6) \cdot f'_t))^{1/2} = 3.473 \text{ in.}$$

$$b = (E_c \cdot d, req'd^3 / (12 \cdot (1 - \mu^2) \cdot k_s))^{1/4} = 22.525 \text{ in.}$$

$$b, req'd = 1.5 \cdot b = 34 \text{ in.}$$

$$P_n = 1.72[(k_s \cdot r_1 / E_c) \cdot 10^4 + 3.6] \cdot f'_t \cdot t^2 = 166,098 \text{ lbs}$$

$$P_a = \phi \cdot P_n = 99,659 \text{ lbs}$$

$$P_{max} / P_a = 0.25$$

SLAB AND SOIL ANALYSIS (ASD)

$$P_{max} = \text{MAX(ASD Load Combo 1, ASD Load Combo 2, ASD Load Combo 3)} \\ = 17,272 \text{ lbs}$$

$$f'_t = 7.5 \cdot (f'_c)^{1/2} = 474 \text{ psi}$$

$$P_n = 1.72[(k_s \cdot r_1 / E_c) \cdot 10^4 + 3.6] \cdot f'_t \cdot t^2 = 166,098 \text{ lbs}$$

$$d, req'd = (P_{max} / (\phi \cdot 1.72 \cdot ((K_s \cdot r_1 / E_c) \cdot 10^4 + 3.6) \cdot f'_t))^{1/2} = 3.473 \text{ in.}$$

$$b = (E_c \cdot d, req'd^3 / (12 \cdot (1 - \mu^2) \cdot k_s))^{1/4} = 22.525 \text{ in.}$$

$$b, req'd = 1.5 \cdot b = 34 \text{ in.}$$

$$P_a = P_n / \Omega = 55,366 \text{ lbs}$$

$$P_{max} / P_a = 0.31$$

Base Plate

Width B 8 in.

Depth W 8 in.

Frame

Frame depth d 42 in.

Concrete

Thickness t 7 in.

f_c 4,000 psi

φ 0.6

Ω 3

λ 1

k_s 50 pci

r₁ 4 in

E_c 3,604,997 psi