



STORMWATER SITE PLAN

Proposed Wesley Homes Puyallup Senior Living Project Phase II

Northwest Corner of 10th Street S.E.
and 39th Avenue S.E.
Puyallup, Washington

CONDITION: Prior to Occupancy, the project's critical area biologist shall evaluate the existing treatment wetland plantings to ensure the wetland plantings are thriving and comply with the current 2019 Ecology Manual criteria. (NOTE: The provided 'wetland tech memo' discusses the regulatory wetlands on the project site, but does not address the stormwater treatment wetland.)

Prepared for:
Wesley Homes

July 15, 2024
Our Job No. 16718



TABLE OF CONTENTS

- 1.0 ANALYSIS OF THE MINIMUM REQUIREMENTS
- 2.0 PROJECT OVERVIEW
- 3.0 EXISTING CONDITIONS SUMMARY
- 4.0 OFF-SITE ANALYSIS REPORT
- 5.0 PERMANENT STORMWATER CONTROL PLAN

APPENDICES

- APPENDIX A CONSTRUCTION STORMWATER POLLUTION PREVENTION PLAN
- APPENDIX B OPERATION AND MAINTENANCE MANUAL
- APPENDIX C PHASE 1 STORMWATER SITE PLAN

1.0 ANALYSIS OF THE MINIMUM REQUIREMENTS

1.0 ANALYSIS OF THE MINIMUM REQUIREMENTS

This is a new development project and meets the threshold for a new development such that all 11 Minimum Requirements apply to this project site. The following is an explanation of how each Minimum Requirement is met.

Minimum Requirement No. 1: Preparation of Stormwater Site Plan.

Response: This Stormwater Site Plan prepared for the project meets the requirements of Minimum Requirement No. 1.

Minimum Requirement No. 2: Construction Stormwater Pollution Prevention Plan.

Response: A Construction Stormwater Pollution Prevention Plan is located within this Final Stormwater Site Plan prepared for this project site as Appendix A.

Minimum Requirement No. 3: Source Control of Pollution.

Response: Available and reasonable Source Control BMPs will be applied to this project for the type of source control pollution being produced on this project site. At the minimum the trash enclosures will be covered, and the parking lot will be swept on a regular basis. In addition, the owner will be educated about the proper use of pesticides and fertilizers on this project site.

Minimum Requirement No. 4: Preservation of Natural Drainage Systems and Outfalls.

Response: This project will continue to discharge to a ditch between the Lowes Home Improvement site and this project site which courses in a northerly direction to Bradley Lake several hundred feet away. This ditch has been modified in the past; however, wetland areas A, C and D, on site will be preserved with this new development and portions of the site runoff will be routed to the wetlands in order to assure that hydrology is maintained. For the Wetlands D and C to the north, hydrology will be maintained through dispersion of runoff from the north building roof. For Wetland A, a flow splitting control structure routes a portion of the detention pond discharge into the wetland. The other portion of the pond discharge routes to the Lowe's drainage ditch as it did under existing conditions. The groundwater collected in the detention pond is collected and discharged back into the wetland as well.

Minimum Requirement No. 5: On-Site Stormwater Management.

Response: The on-site stormwater management system was previously sized and installed under Phase 1 to handle the full buildout of the site. Minor modifications are proposed with Phase 2. The project will evaluate List 2 of the Manual for onsite stormwater management compliance. These BMPs were evaluated and discussed as follows:

Lawn and Landscape Areas

Soil Preservation and Amendment (Ecology BMP T5.13)

All disturbed pervious areas that are not converted to hard surfaces will apply soil amendment per Ecology BMP T5.13.

Roof Areas

Full dispersion (BMPT5.30) was applied to portions of the site in Phase 1 to maintain wetland hydrology. A portion of the roof areas is directed to the onsite wetlands through a dispersion trench for each wetland to maintain hydrology.

Downspout full infiltration (BMPT5.10A) and Bioretention (BMPT7.30) were deemed infeasible due to shallow groundwater seepage. Please refer to the Geotechnical Report Addendum dated December 29, 2022.

Downspout Dispersion (BMPT5.10B) was deemed feasible and is being applied to a portion of the roofs under BMPT5.30.

Perforated Stub-out connections (BMPT5.10C) are not proposed due to shallow seepage and the potential to introduce subsurface flows into foundations and footings.

Other Hard Surfaces

Full dispersion (BMPT5.30) was not applied to additional hard surfaces within the site due to wetland hydrology limitations. Roof surfaces are being dispersed to wetlands and hydrology is already met.

Permeable Pavement (BMPT5.15) was deemed infeasible due to shallow groundwater seepage. Please refer to the Geotechnical Report Addendum dated December 29, 2022.

Bioretention (BMPT7.30) was deemed infeasible due to shallow groundwater seepage. Please refer to the Geotechnical Report Addendum dated December 29, 2022.

Sheet Flow Dispersion (BMPT5.12) and Concentrated Flow Dispersion (BMPT5.11) were deemed infeasible due to wetland hydrology limitations. Roof surfaces are being dispersed to wetlands and hydrology is already met.

Minimum Requirement No. 6: Runoff Treatment.

Response: This project site contains an existing stormwater treatment wetland (BMP T10.30) below the live detention storage for water quality treatment prior to discharging to the on-site ditch that flows to Bradley Lake. This offers enhanced treatment, as Bradley Lake is a fish bearing lake which requires enhanced water quality treatment. The constructed wetland is located under the live storage and the 2-year mitigated discharge rate is less than 3 feet above the static water surface elevation. In this case the 2-year release is 0.11 cfs and this occurs at approximately 3 feet above static water surface elevation per the stage storage table calculated in WWHM 2012. There is an access road to the west of the site that is treated for water quality by use of a Stormfilter Catchbasin. This has been sized to treat the 91st percentile of storm events through WWHM water quality calculations before entering the pond, as the outlet of the pipe is near the end of the stormwater treatment wetland and therefore would not be receiving adequate treatment through the pond alone.

The stormwater treatment system was previously sized and installed under Phase 1 to handle the full buildout of the site. The total impervious surface accounted for under Phase 1 was compared to the final Phase 2 site plan and confirmed adequate. See Phase 1 SSP located within Appendix C of this report for further detail.

Minimum Requirement No. 7: Flow Control.

Response: This project provides flow control in the form of a detention pond located above a stormwater treatment wetland according to City of Puyallup standards, which was originally designed under the 2005 Department of Ecology Manual for Western Washington as their criteria setting requirement for detention. This is a duration matching standard and utilizes the 2012 Western Washington Hydrology Model (WWHM). The prior calculations have been updated using the most current version of WWHM and some minor adjustments to basin areas.

The detention pond that was previously sized and installed under Phase 1 will be modified to raise the live water surface by 0.8-feet and update the control structure.

Minimum Requirement No. 8: Wetlands Protection.

Response: The wetlands will be protected and maintained in perpetuity on this site. Please refer to the Wetland Exhibit as well as the Grading and Storm Drainage Plan that shows how these wetlands will maintain hydrology after development of this project site. A portion of the runoff from the North Building is routed to Wetlands C and D adjacent to the North Building to maintain the wetland hydrology. A flow splitter will route a portion of the discharge from the detention pond to Wetland A in order to maintain wetland hydrology. The outfall to this wetland is lower than the outfall to the adjacent drainage ditch to ensure groundwater and the appropriate amount of runoff is directed to Wetland A. Runoff routed to the wetlands is discharged through a dispersion trench for each wetland. A hydroperiod analysis for each wetland can be found in the Wetland Exhibit within section 5.0 of this report.

Minimum Requirement No. 9: Basin/Watershed Planning.

Response: This project site is located in the "State Highway Basin" planning area of the City of Puyallup. No additional requirements are required by that plan.

Minimum Requirement No. 10: Operation and Maintenance.

Response: An Operation and Maintenance Manual is located within this Final Stormwater Site Plan as Appendix B.

Minimum Requirement #11: Off-Site Analysis and Mitigation

An offsite analysis was prepared within the original Phase 1 permit documents and can be found in Appendix C of this report.

2.0 PROJECT OVERVIEW

2.0 PROJECT OVERVIEW

The proposed Wesley Homes Senior Living Project 2 project is located on a 14.36-acre site located within a portion of the Southwest quarter of Section 3, Township 19 North, Range 4 East, Willamette Meridian, City of Puyallup, Pierce County, Washington. More particularly, the site is located on the northwest corner of 10th Street S.E. and 39th Avenue S.E. within the City of Puyallup. Please see the attached Vicinity Map in section 4.0 for an exact depiction of the project site.

The scope of work for this proposal is to construct two additional buildings with associated parking/walkways and utilities. The additional buildings and parking/walkways total approximately 2.33 acres of impervious surface. The prior WWHM calculations have been updated using the most current version of WWHM and some minor adjustments to basin areas. Please refer to Section 5.0 for updated calculations and Appendix C for previous storm calculations.

3.0 EXISTING CONDITIONS SUMMARY

3.0 EXISTING CONDITIONS SUMMARY

Current conditions at the site include the Phase 1 buildout which contains 2 existing buildings, utilities, access, parking, landscaping, and stormwater controls. A portion of the rooftops drain to existing onsite wetlands to maintain hydrology and the remainder of the site drains to the existing stormwater pond constructed during Phase 1.

Ultimately, the site drains to Bradley Lake a couple hundred feet northward of the project site.

There are two basin areas on the developed site; the northern basin that drains to Wetland C and D and the southern basin that drain to the stormwater pond which are shown as an exhibit within Section 5.0. The existing wetland areas are also shown as an exhibit within Section 5.0. This exhibit shows the tributary areas to the existing wetlands on-site.

The Soil Survey Map shows that the site is mostly Everett gravelly sandy loam with areas of Kitsap silt loam and Neilton gravelly loamy sand. This map is shown as an exhibit in Section 4.0. Further discussion of the soils can be found in the soils report located in Section 5.0.

VICINITY MAP

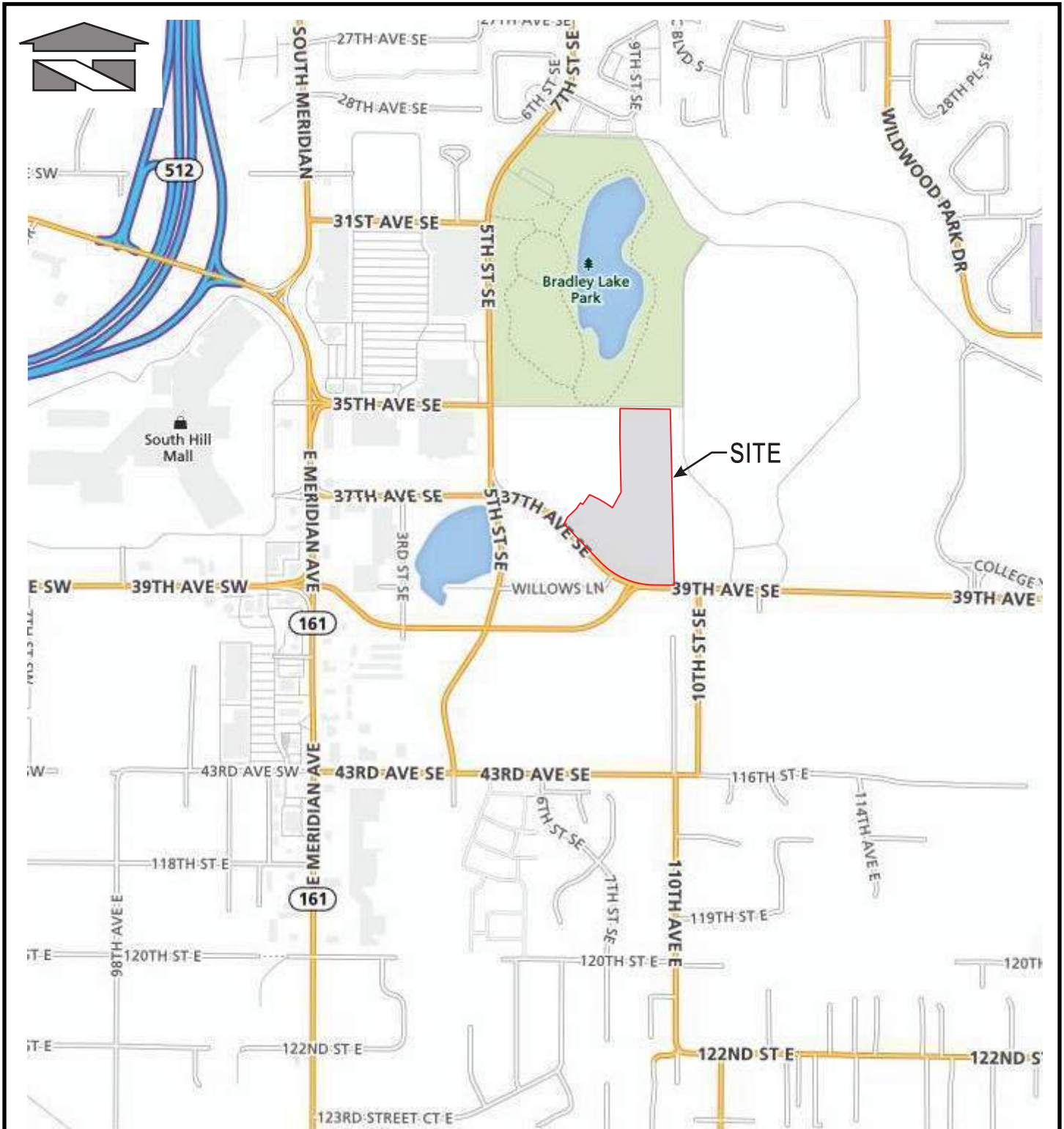

REFERENCE: Rand McNally (2015)

Scale:

Horizontal: N.T.S.

Vertical: N/A



18215 72ND AVENUE SOUTH
 KENT, WA 98032
 (425) 251-6222
 (425) 251-8782

CIVIL ENGINEERING, LAND PLANNING,
 SURVEYING, ENVIRONMENTAL SERVICES

For:

Wesley Homes
 Puyallup, Washington

Title:

VICINITY MAP

Job Number

16718

DATE: 6/30/15

ASSESSOR'S MAP

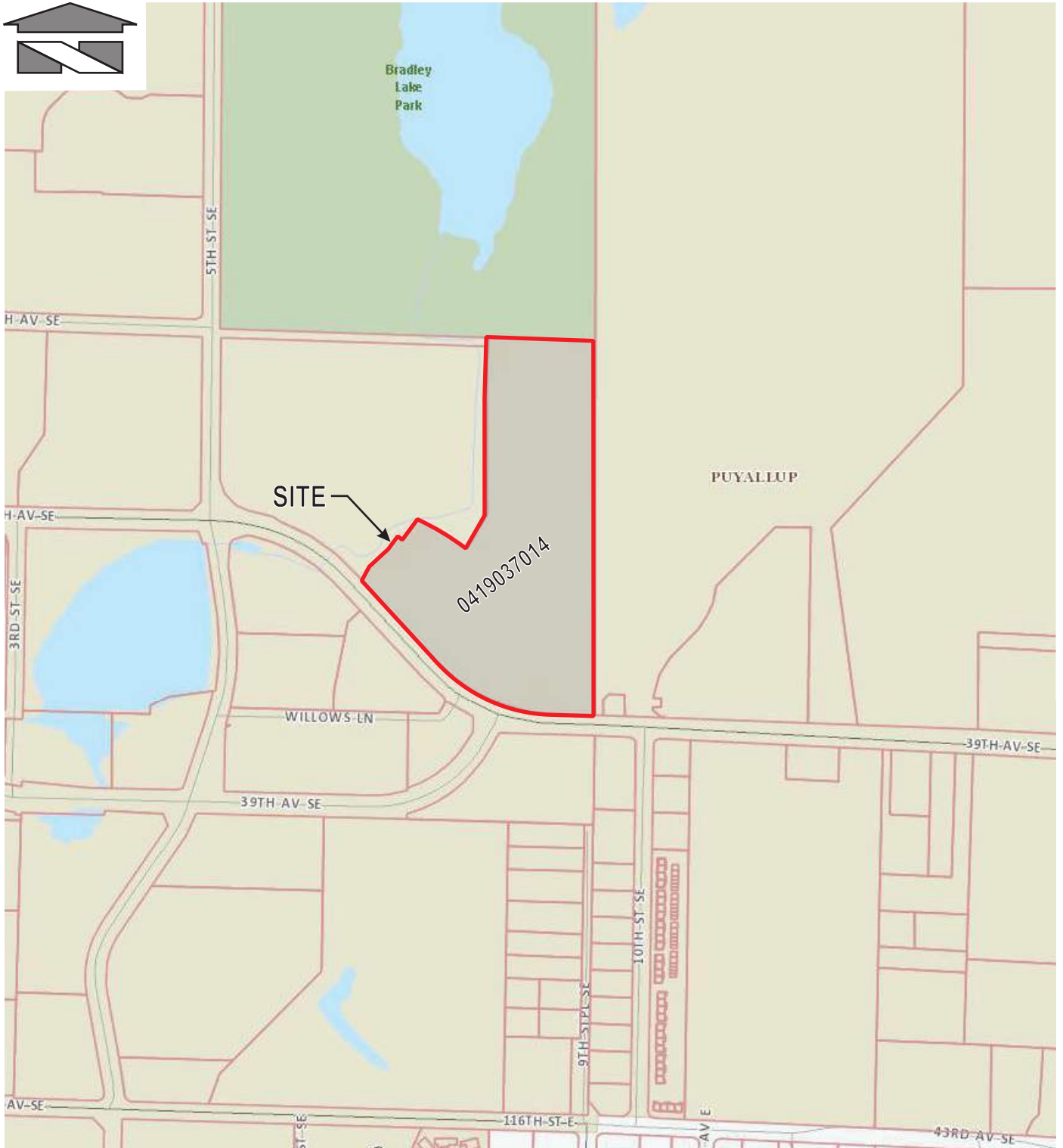

REFERENCE: Pierce County Department of Assessments

Scale:

Horizontal: N.T.S.

Vertical: N/A



18215 72ND AVENUE SOUTH
KENT, WA 98032
(425) 251-6222
(425) 251-8782

CIVIL ENGINEERING, LAND PLANNING,
SURVEYING, ENVIRONMENTAL SERVICES

For:

Wesley Homes
Puyallup, Washington

Title:

ASSESSOR MAP

Job Number

16718

DATE: 6/30/15

FEMA MAP

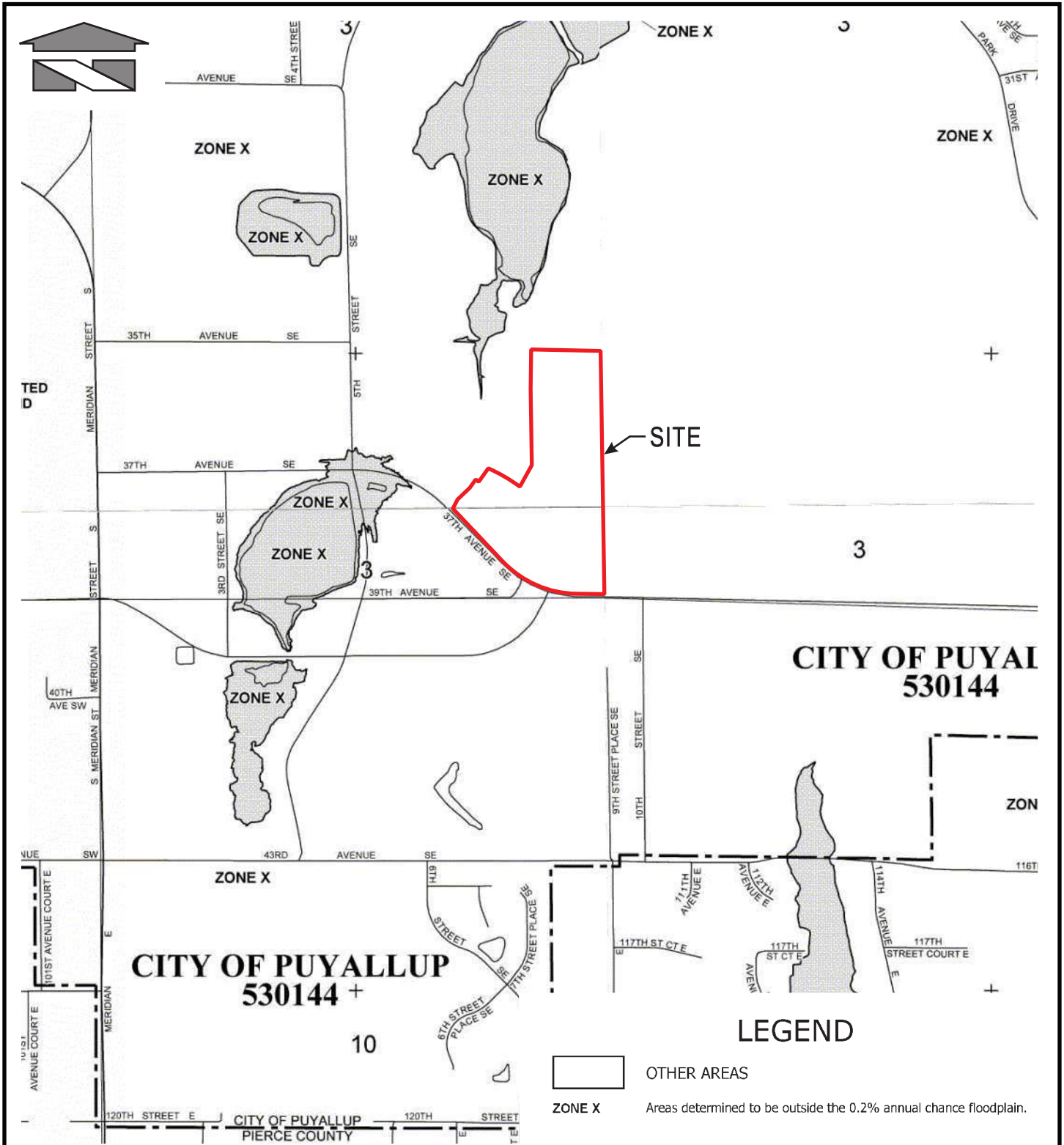

REFERENCE: Federal Emergency Management Agency (Portion of Maps 53053C0341E & 53053C0343E, Mar. 2017)

<p>Scale:</p> <p>Horizontal: N.T.S. Vertical: N/A</p>	<p>For:</p> <p>Wesley Homes Puyallup, Washington</p>	<p>Job Number</p> <p>16718</p>
 <p>18215 72ND AVENUE SOUTH KENT, WA 98032 (425) 251-6222 (425) 251-8782</p> <p>CIVIL ENGINEERING, LAND PLANNING, SURVEYING, ENVIRONMENTAL SERVICES</p>	<p>Title:</p> <p>FEMA MAP</p>	<p>DATE: 3/16/17</p>

SOILS MAP



REFERENCE: USDA, Natural Resources Conservation Service

LEGEND:

- 13B = Everett gravelly sandy loam, 0-6% slopes
- 20B = Kitsap silt loam, 2-8% slopes
- 24D = Neilton gravelly loamy sand, 8-25% slopes

<p>Scale: Horizontal: N.T.S. Vertical: N/A</p>	<p>For: Wesley Homes Puyallup, Washington</p>	<p>Job Number 16718</p>
 <p>18215 72ND AVENUE SOUTH KENT, WA 98032 (425) 251-6222 (425) 251-8782</p> <p>CIVIL ENGINEERING, LAND PLANNING, SURVEYING, ENVIRONMENTAL SERVICES</p>	<p>Title: SOIL SURVEY MAP</p>	<p>DATE: 6/30/15</p>

4.0 OFF-SITE ANALYSIS REPORT

4.0 OFF-SITE ANALYSIS REPORT

As mentioned previously, the site drains almost immediately into a drainage channel adjacent to the west property line of the project site and courses northerly and within 200 to 300 feet discharges into Bradley Lake, a fairly large water body located within the City of Puyallup City Limits. Bradley Lake backwaters into the ditch conveyance system during peak storm events; however, that ditch conveyance system is much lower in elevation than the proposed project site development area and there is no perceptible impact to the development area.

There is no upstream basin contributing runoff to this project site as 39th Avenue S.E. forms the project site's southern boundary and has its own conveyance and collection system. To the east, the area is developed with its own conveyance and collection system. There is approximately 1.01 acres of vegetated land to the east that could drain towards the site. The runoff for the 10-year storm is calculated to be 0.0073 cfs, spanning over 1,282 feet, and would therefore be negligible.

5.0 PERMANENT STORMWATER CONTROL PLAN

5.0 PERMANENT STORMWATER CONTROL PLAN

Part A Existing Site Hydrology

The on-site stormwater management system was previously constructed under Phase 1. The predeveloped condition used for flow control sizing was a till forest condition which produces small release rates and therefore impact to the downstream drainage course is considered negligible. Please refer to basin maps and WWHM sizing for additional information.

Part B Developed Site Hydrology

Under developed conditions there are two separate drainage basins on the project site, both of which will drain to the same drainage channel after being routed through wetland areas after detention and treatment in the south basin and roof runoff matching hydrology to the north basin. The total area of the south basin is 10.1 acres with 6.27 acres of impervious surface and the north basin consists of 0.75 acres of rooftop that is fully dispersed to the wetlands. The current version of WWHM was used in sizing the updated detention volume in accordance with the 2019 DOE Manual. Calculations can be found within this section as well as the developed basin exhibit.

Part C Performance Standards and Goals

The project meets Flow Control Standards per the 2019 Department of Ecology Stormwater Management Manual. The conveyance system for this project site was sized using the Santa Barbara Urban Hydrograph (SBUH) methodology and the rational method which are accepted conveyance standards as allowed by the 2019 DOE Manual. Enhanced water quality treatment is being provided through the existing Stormwater Treatment Wetland (BMP T10.30).

Part D Flow Control System

This project provides flow control in the form of a detention pond located above a stormwater treatment wetland according to City of Puyallup standards, which was originally designed under the 2005 Department of Ecology Manual for Western Washington as their criteria setting requirement for detention. This is a duration matching standard and utilizes the 2012 Western Washington Hydrology Model (WWHM).

The prior detention calculations have been updated using the most current version of WWHM and some minor adjustments to basin areas. To accommodate the full buildout of the site, the pond water surface is being raised by 0.8-feet. The required detention volume is 139,697 cubic feet with approximately 152,482 cubic being provided. The existing facility will also provide 1.2-feet of freeboard. To accommodate the added detention volume, the existing flow control structure will be modified. Please refer to calculations within this section.

Part E Water Quality System

This project site contains an existing stormwater treatment wetland (BMP T10.30) below the live detention storage for water quality treatment prior to discharging to the on-site ditch that flows to Bradley Lake. This offers enhanced treatment, as Bradley Lake is a fish bearing lake which requires enhanced water quality treatment. The constructed stormwater wetland is located under the live storage and the 2-year mitigated discharge rate is less than 3 feet above the static water surface elevation. There is an access road to the west of the site that is treated for water quality by use of an existing Stormfilter

Catch basin which was sized to treat the 91st percentile of storm events through WWHM water quality calculations before entering the pond, as the outlet of the pipe is near the end of the stormwater treatment wetland and therefore would not be receiving adequate treatment through the pond alone. An additional Stormfilter catch basin is proposed for the access and parking area to the south of the new Care Center expansion.

The stormwater wetland was previously sized and installed under Phase 1 to handle the full buildout of the site. See Phase 1 SSP located within Appendix C of this report for further detail.

There are underground garages for the proposed development. As this development is a senior living facility, the assumed traffic in and out of the garages is relatively small and it is assumed that the event creating the most runoff would be when the garage is washed out by a garden hose or pressure washer. A typical garden hose has a flow of less than 5 GPM. The proposed oil water separators for this site have a design flow rate of 27 GPM with a max process flow rate of 144 GPM. This is more than adequate to treat the runoff from the parking garages. There are also driveway trench drains before entering the garage, which reduces stormwater runoff from outside the garages, if any. The required coalescing surface area is 45.2 square feet. The oil water separators provide a total coalescing area of 111 square feet. A coalescing surface area calculation is provided in the following pages.

A grease interceptor is required for the discharge from the kitchen to the sanitary sewer. Calculations have been provided on the following pages to determine the 1,000 gallon unit is adequate for this site.

Part F Conveyance System Analysis and Design

The on-site stormwater management system was previously sized and installed under Phase 1 to handle the full buildout of the site. The site contains adequate stormwater conveyance facilities to serve the Phase 2 project.

OIL/WATER SEPARATOR DETAILS

BMP T11.11: Coalescing Plate (CP) Separator

Design Criteria:

$$A_h = Q/V_t = [Q] / [(0.00386) * ((S_w - S_o) / (\mu_w))] \quad (\text{eq: pg1002 2019SWMMWW})$$

A_h = Horizontal surface area of the plates (ft²)

Q = (k) see Figure V-7.7: Ratio of SBUH Peak/WQ Flow (Online)

V_t = rise rate of the oil droplet (ft/min)

S_w = specific gravity of water at the design temperature

S_o = specific gravity of oil at the design temperature

μ_w = absolute viscosity of the water (poise)

Solution :

$$Q = 1.6$$

$$V_t = 0.00386 * \frac{1-0.88}{0.0131} = 0.0354 \text{ ft/min}$$

$$A_h = \frac{1.6}{0.0354} = 45.2 \text{ ft}^2$$

253-CPS

COVER with ADJUSTABLE FRAME No. 25P ASSEMBLY

220 lbs.

Suitable for use in off-street locations where not subjected to high density traffic.

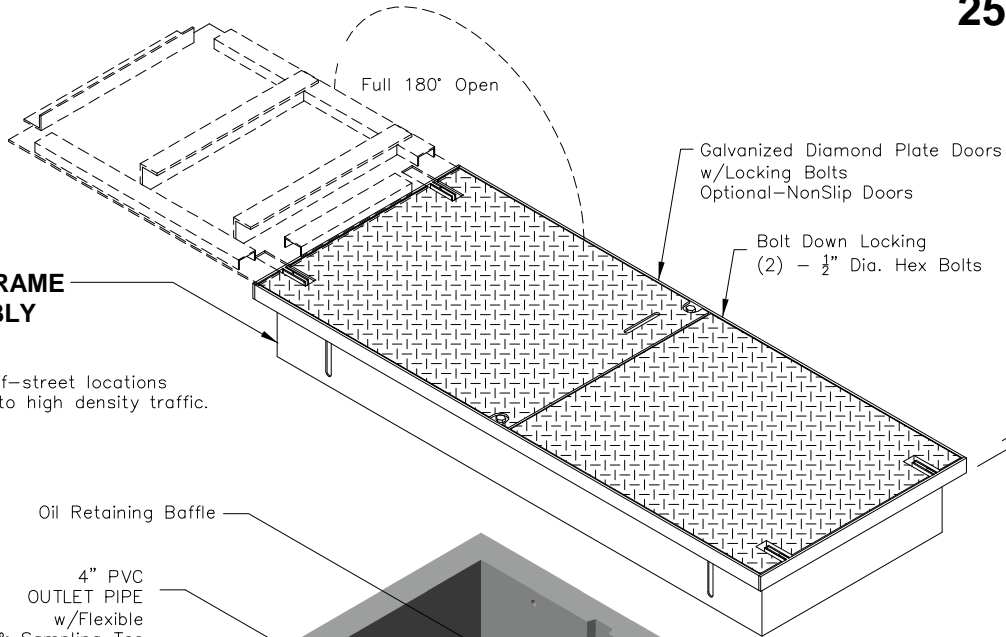

BASE ASSEMBLY No. 253-B-CPS

2,195 lbs.

Base	2,000 lbs.
Baffle Wall	95 lbs.
Weir Wall	100 lbs.
Total	2,195 lbs.

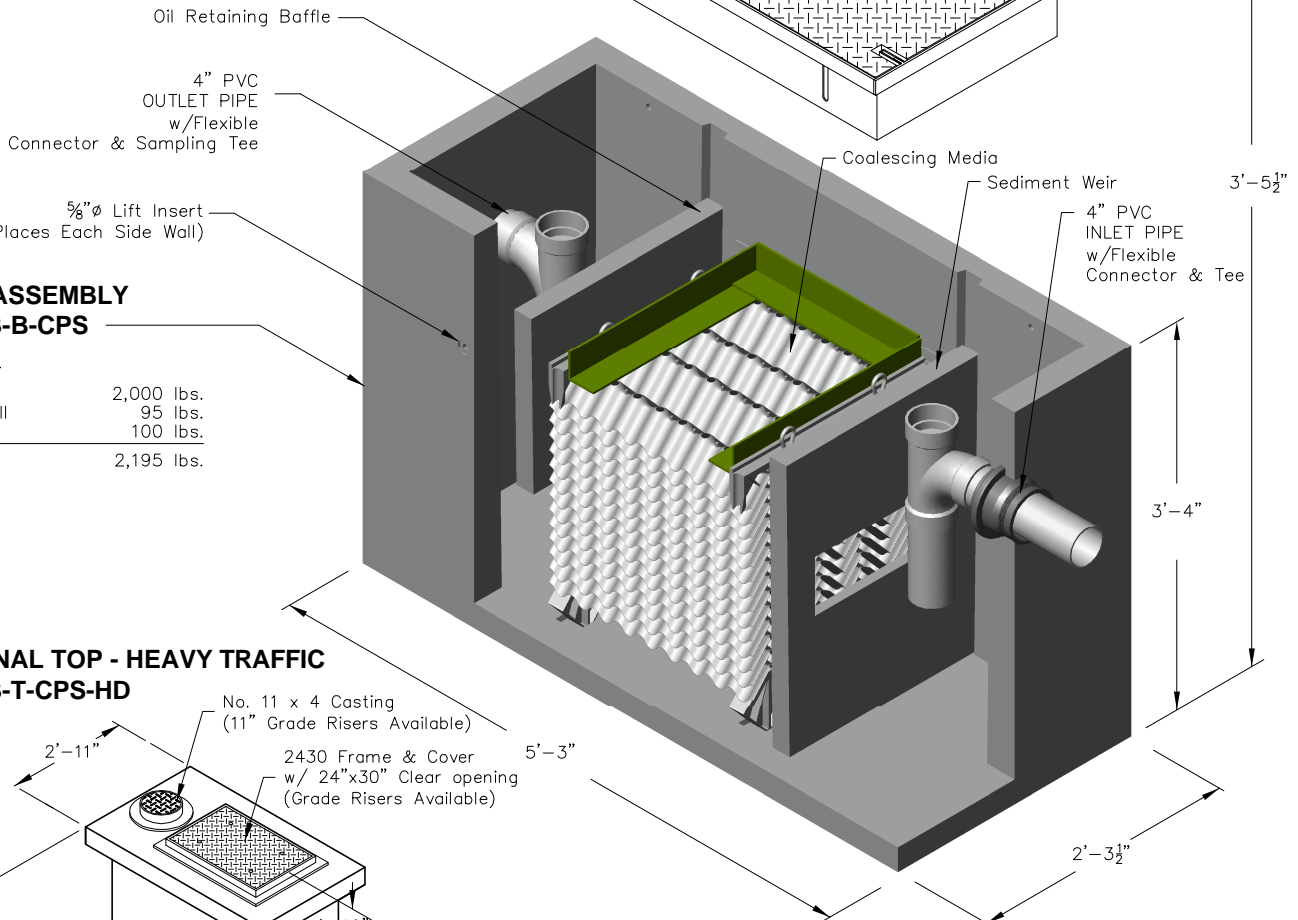

OPTIONAL TOP - HEAVY TRAFFIC No. 253-T-CPS-HD

1,100 lbs.

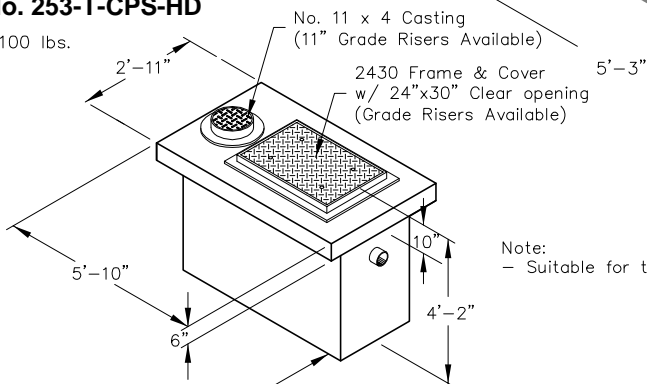

Note:
- Suitable for traffic locations.

No-253-B-CPS
2,195 lbs.

Note: Designed for 0 to 5'-0" of Cover

 <p>PO Box 323, Wilsonville, Oregon 97070-0323 Tel: (503) 682-2844 Fax: (503) 682-2657</p>	253-CPS	253-CPS OIL / WATER SEPARATOR COALESCING - 27 GPM
	File Name: 020-253CPS	
	Issue Date: 2018	
	oldcastleprecast.com/wilsonville	

253-CPS

Projected Coalescing Plate Area = 111 Sq.Ft.
 *Design Flow Rate = 27 GPM
 Maximum Process Flow = 144 GPM

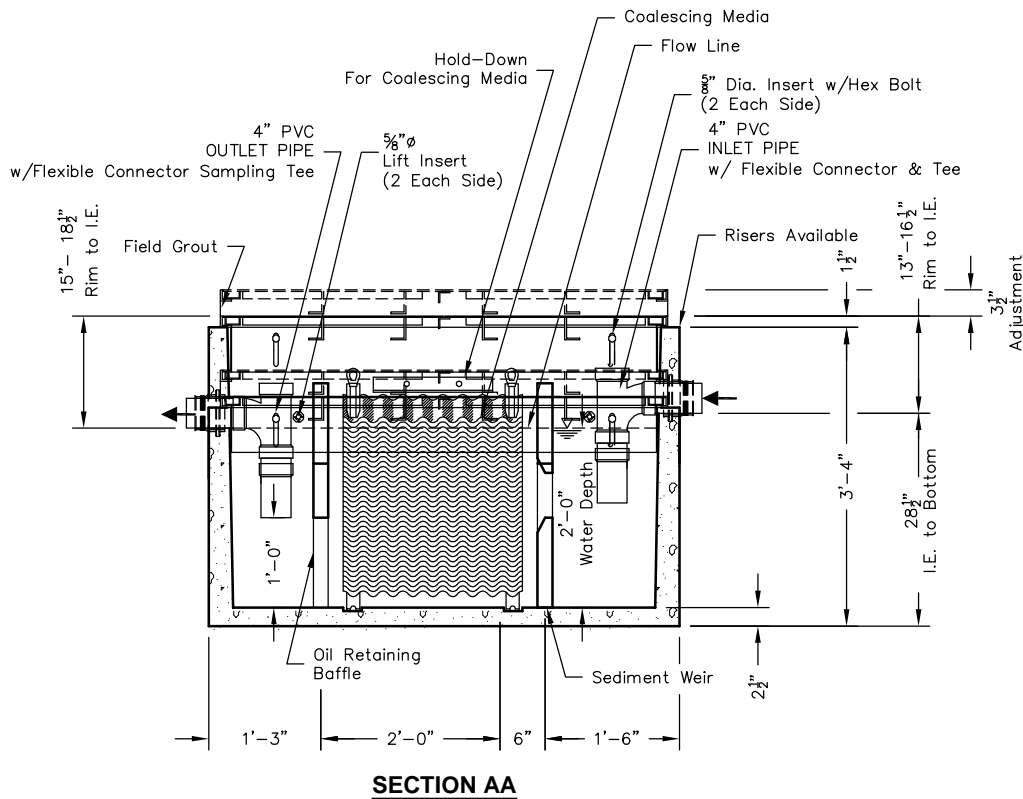
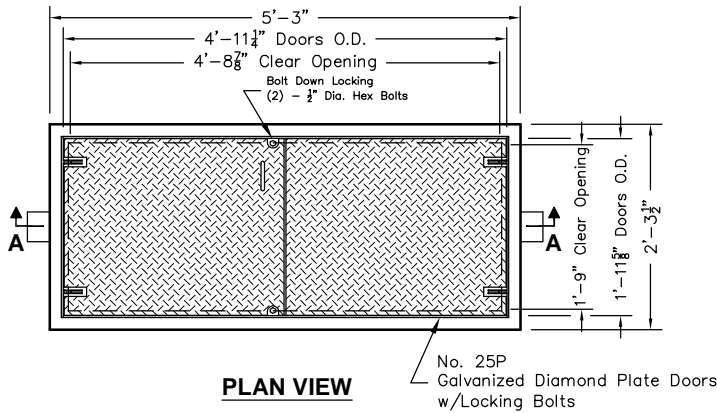

*DESIGN FLOW RATE	EFFLUENT QUALITY	100% COLLECTED SIZE
27 GPM	10 ppm	60 Micron

Basic Design Information: *

- Influent Characteristics
- Oil Specific Gravity = 0.88
- Operating Temperature = 50°
- Influent Oil Concentration = 100 ppm
- Mean Oil Droplet Size = 130 Microns
- .033 ft/min. Critical Oil Droplet Predicted Rise Rate

Notes:

- Static Water Depth = 2'-0"
- Prior to "Startup" of system, fill with clean water to bottom of outlet pipe. For best results, fill to flow line.
- Follow Regular Inspection, Cleaning, & Maintenance Schedule (See Clean Out & Maintenance).

*Basic Design Information per Washington State Department of Ecology; User to Adjust Estimates for Variations in Real Conditions.

 <p>PO Box 323, Wilsonville, Oregon 97070-0323 Tel: (503) 682-2844 Fax: (503) 682-2657</p>	<h2>253-CPS</h2>	<h2>253-CPS</h2> <h3>OIL / WATER SEPARATOR</h3> <h3>COALESCING - 27 GPM</h3>
	File Name: 020-253CPS	
	Issue Date: 2018	
	oldcastleprecast.com/wilsonville	

GREASE INTERCEPTOR SIZING

GREASE INTERCEPTOR SIZING

A grease interceptor is required for the kitchen in the proposed Care Center. This was determined by calculating the number of drainage fixture units (DFUs) for the proposed facility, and using that number in table 1014.3.6 of the Uniform Plumbing Code (UPC) to determine the appropriate grease-interceptor size. Below is a summary of the fixtures and calculations.

KITCHEN FIXTURE SUMMARY:

FLOOR DRAINS x 4 x (2 DFU)	= 8 DFU
HAND SINKS x 4 x (2 DFU)	= 8 DFU
PREP SINKS x 1 x (3 DFU)	= 3 DFU
MOP SINK x 1 x (3 DFU)	= 3 DFU
DISHWASHER x 1 x (2 DFU)	= 2 DFU
INDIRECT WASTE x 7 x (1 DFU)	= 7 DFU
TOTAL	= 31 DFU

CAPACITY:

Total number of DFUs based on the kitchen fixture connection schedule from plumbing plan sheet P0.01 and summarized above = **31 DFU**



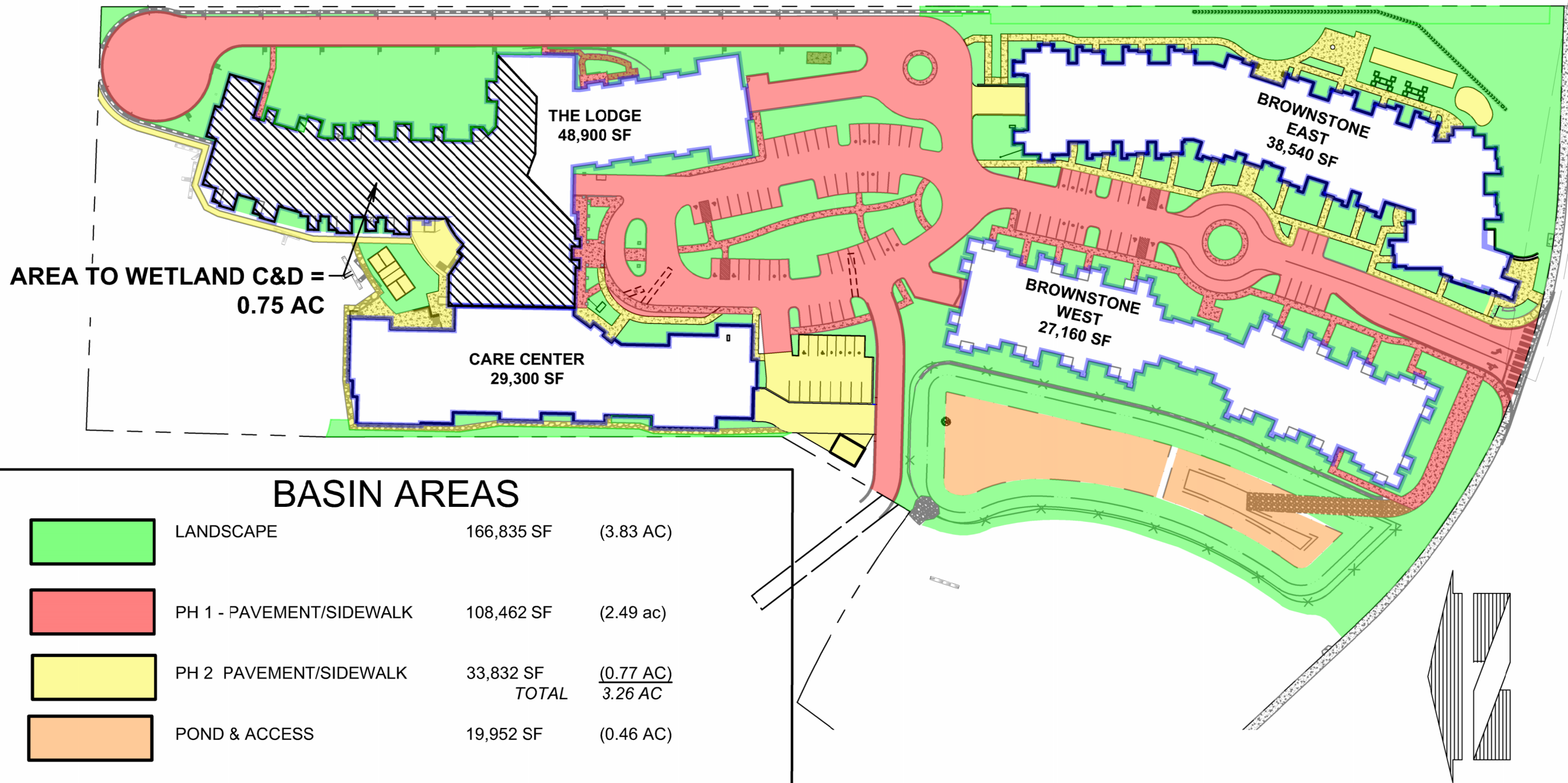

Per table 1014.3.6 UPC minimum grease interceptor sizing = 1000 gallons

BASIN MAP

PHASE 1 & 2 - DEVELOPED BASIN MAP



BASIN AREAS

	LANDSCAPE	166,835 SF	(3.83 AC)
	PH 1 - PAVEMENT/SIDEWALK	108,462 SF	(2.49 ac)
	PH 2 PAVEMENT/SIDEWALK	33,832 SF	(0.77 AC)
	TOTAL		3.26 AC
	POND & ACCESS	19,952 SF	(0.46 AC)
	ROOF		
	THE LODGE (PH1)	48,900 SF	
	CARE CENTER (PH2)	29,300 SF	
	BROWNSTONE WEST (PH1)	27,160 SF	
	BROWNSTONE EAST (PH2)	38,540 SF	
	TOTAL ROOF	143,900 SF	(3.30 AC)

TOTAL BASIN AREA = 10.85 AC

ROOF AREA TRIBUTARY TO POND	= 2.55 AC
ROOF AREA TRIBUTARY TO WETLANDS	= 0.75 AC
PAVEMENT/SIDEWALK TO POND	= 3.26 AC

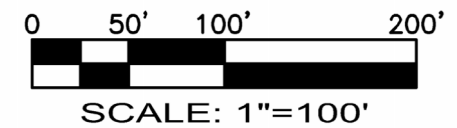

No.	Date	By	Ckd.	Appr.	Revision

Title: **DEVELOPED BASIN MAP**
PHASE 1 AND 2

For: **WESLEY HOMES**

Designed	---	Scale:	Horizontal
Drawn	---		1"=100'
Checked	---	Vertical	-
Approved	DKB		
Date	1/25/23		

Barghausen Consulting Engineers, Inc.
18215 72nd Avenue South
Kent, WA 98032
425.251.6222 barghausen.com

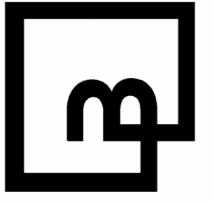

Job Number
16718

Sheet
1 of 1

WETLAND DEVELOPED AREAS MAP FOR WESLEY HOMES PUYALLUP

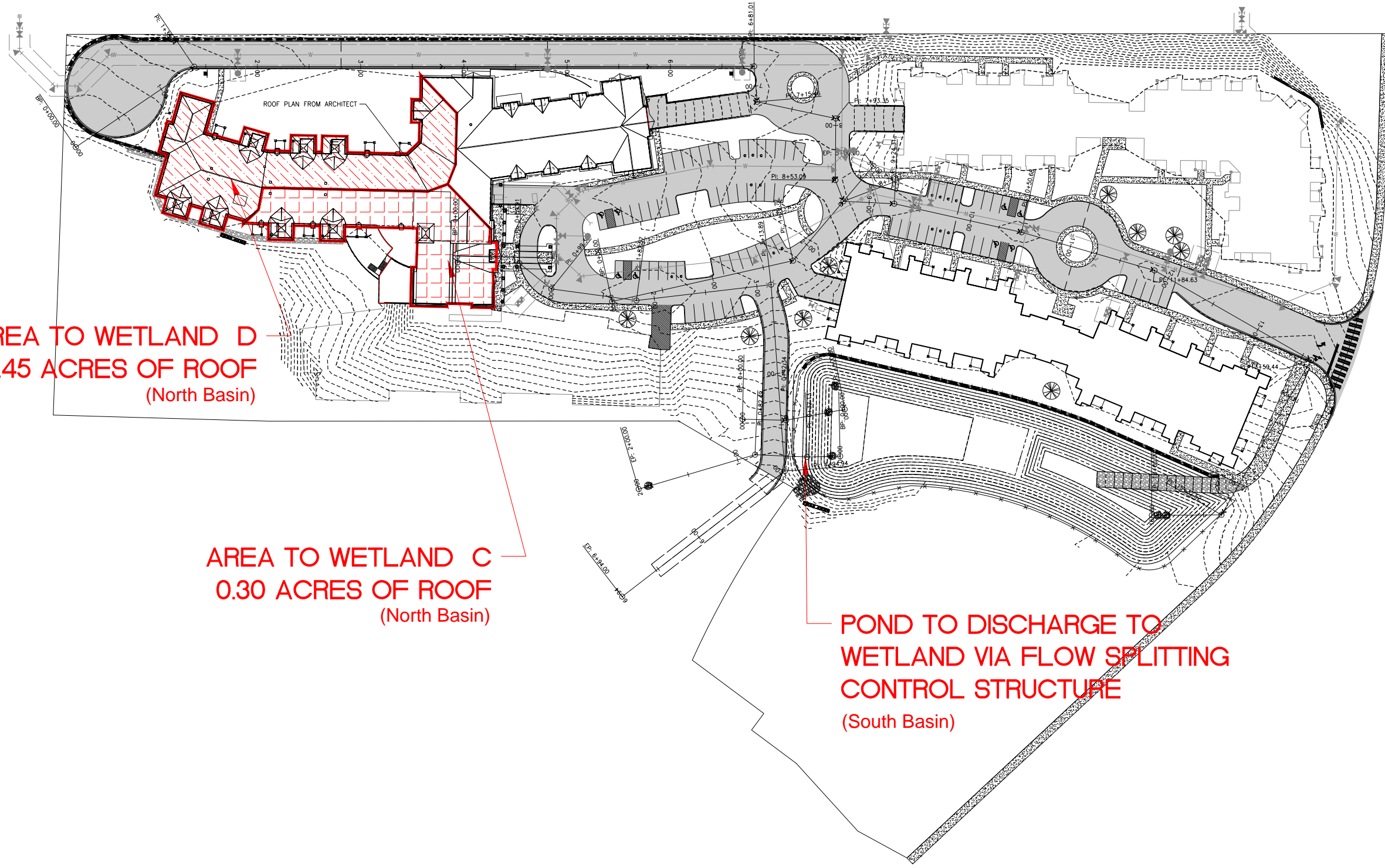
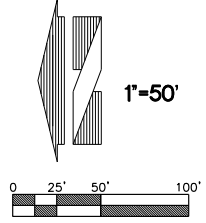

AREA TO WETLAND D
0.45 ACRES OF ROOF
(North Basin)

AREA TO WETLAND C
0.30 ACRES OF ROOF
(North Basin)

POND TO DISCHARGE TO
WETLAND VIA FLOW SPLITTING
CONTROL STRUCTURE
(South Basin)

Job Number
16718

Sheet
1 of 1

BARGHAUSEN & ASSOCIATES
CONSULTING ENGINEERS, INC.

18215 72ND AVENUE SOUTH
KENT, WA 98032
(425)251-6222
(425)251-8782 FAX

CIVIL ENGINEERING, LAND PLANNING,
SURVEYING, ENVIRONMENTAL SERVICES

Date/Time: 5/26/2017 9:46 AM Scale: 1" = 1'

Designed CP
Drawn CK
Checked CP
Approved CP
Date 5/25/14

Scale:
Horizontal 1"=60'
Vertical N/A

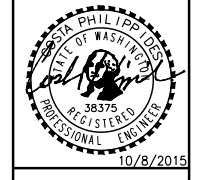

For:
WESLEY HOMES
PUYALLUP, WA

Title:
WETLAND DEVELOPED AREAS MAP
WESLEY HOMES
PUYALLUP, WA

Revision
No. Date By Ctd. Appr.

WWHM CALCULATIONS

WWHM2012
PROJECT REPORT

General Model Information

Project Name: 16718-POND
Site Name:
Site Address:
City:
Report Date: 7/13/2024
Gage: 40 IN EAST
Data Start: 10/01/1901
Data End: 09/30/2059
Timestep: 15 Minute
Precip Scale: 1.000
Version Date: 2021/08/18
Version: 4.2.18

POC Thresholds

Low Flow Threshold for POC1:	50 Percent of the 2 Year
High Flow Threshold for POC1:	50 Year

Landuse Basin Data

Predeveloped Land Use

Basin 1

Bypass:	No
GroundWater:	No
Pervious Land Use C, Forest, Flat	acre 10.85
Pervious Total	10.85
Impervious Land Use	acre
Impervious Total	0
Basin Total	10.85

Element Flows To:		
Surface	Interflow	Groundwater

Mitigated Land Use

Basin 1

Bypass: No

GroundWater: No

Pervious Land Use acre
C, Pasture, Flat 3.83

Pervious Total 3.83

Impervious Land Use acre
ROOF TOPS FLAT 2.55
PARKING FLAT 3.26
POND 0.46

Impervious Total 6.27

Basin Total 10.1

Element Flows To:

Surface	Interflow	Groundwater
Trapezoidal Pond 1	Trapezoidal Pond 1	

Basin 2

Bypass: Yes

GroundWater: No

Pervious Land Use
C, Lawn, Flat acre
0.75

Pervious Total 0.75

Impervious Land Use acre

Impervious Total 0

Basin Total 0.75

Element Flows To:
Surface

Interflow

Groundwater

Routing Elements
Predeveloped Routing

Mitigated Routing

Trapezoidal Pond 1

Bottom Length: 55.00 ft.
 Bottom Width: 340.00 ft.
 Depth: 6.61 ft.
 Volume at riser head: 3.3476 acre-feet.
 Side slope 1: 3 To 1
 Side slope 2: 3 To 1
 Side slope 3: 3 To 1
 Side slope 4: 3 To 1
 Discharge Structure
 Riser Height: 5.61 ft.
 Riser Diameter: 18 in.
 Notch Type: Rectangular
 Notch Width: 0.111 ft.
 Notch Height: 1.272 ft.
 Orifice 1 Diameter: 1.45 in. Elevation:0 ft.
 Element Flows To:
 Outlet 1 Outlet 2

Pond Hydraulic Table

Stage(feet)	Area(ac.)	Volume(ac-ft.)	Discharge(cfs)	Infilt(cfs)
0.0000	0.429	0.000	0.000	0.000
0.0734	0.433	0.031	0.015	0.000
0.1469	0.437	0.063	0.021	0.000
0.2203	0.441	0.095	0.026	0.000
0.2938	0.445	0.128	0.030	0.000
0.3672	0.449	0.161	0.034	0.000
0.4407	0.453	0.194	0.037	0.000
0.5141	0.457	0.227	0.040	0.000
0.5876	0.461	0.261	0.043	0.000
0.6610	0.465	0.295	0.046	0.000
0.7344	0.469	0.330	0.048	0.000
0.8079	0.473	0.364	0.051	0.000
0.8813	0.477	0.399	0.053	0.000
0.9548	0.482	0.434	0.055	0.000
1.0282	0.486	0.470	0.057	0.000
1.1017	0.490	0.506	0.059	0.000
1.1751	0.494	0.542	0.061	0.000
1.2486	0.498	0.578	0.063	0.000
1.3220	0.502	0.615	0.065	0.000
1.3954	0.506	0.652	0.067	0.000
1.4689	0.511	0.690	0.069	0.000
1.5423	0.515	0.727	0.070	0.000
1.6158	0.519	0.765	0.072	0.000
1.6892	0.523	0.804	0.074	0.000
1.7627	0.527	0.842	0.075	0.000
1.8361	0.532	0.881	0.077	0.000
1.9096	0.536	0.920	0.078	0.000
1.9830	0.540	0.960	0.080	0.000
2.0564	0.544	1.000	0.081	0.000
2.1299	0.548	1.040	0.083	0.000
2.2033	0.553	1.080	0.084	0.000
2.2768	0.557	1.121	0.086	0.000

2.3502	0.561	1.162	0.087	0.000
2.4237	0.566	1.204	0.088	0.000
2.4971	0.570	1.245	0.090	0.000
2.5706	0.574	1.288	0.091	0.000
2.6440	0.578	1.330	0.092	0.000
2.7174	0.583	1.373	0.094	0.000
2.7909	0.587	1.416	0.095	0.000
2.8643	0.591	1.459	0.096	0.000
2.9378	0.596	1.502	0.097	0.000
3.0112	0.600	1.546	0.099	0.000
3.0847	0.605	1.591	0.100	0.000
3.1581	0.609	1.635	0.101	0.000
3.2316	0.613	1.680	0.102	0.000
3.3050	0.618	1.725	0.103	0.000
3.3784	0.622	1.771	0.104	0.000
3.4519	0.626	1.817	0.106	0.000
3.5253	0.631	1.863	0.107	0.000
3.5988	0.635	1.910	0.108	0.000
3.6722	0.640	1.957	0.109	0.000
3.7457	0.644	2.004	0.110	0.000
3.8191	0.649	2.051	0.111	0.000
3.8926	0.653	2.099	0.112	0.000
3.9660	0.658	2.147	0.113	0.000
4.0394	0.662	2.196	0.114	0.000
4.1129	0.667	2.245	0.115	0.000
4.1863	0.671	2.294	0.116	0.000
4.2598	0.676	2.343	0.117	0.000
4.3332	0.680	2.393	0.118	0.000
4.4067	0.685	2.443	0.126	0.000
4.4801	0.689	2.494	0.140	0.000
4.5536	0.694	2.544	0.157	0.000
4.6270	0.698	2.596	0.176	0.000
4.7004	0.703	2.647	0.198	0.000
4.7739	0.707	2.699	0.221	0.000
4.8473	0.712	2.751	0.246	0.000
4.9208	0.717	2.804	0.271	0.000
4.9942	0.721	2.856	0.298	0.000
5.0677	0.726	2.910	0.325	0.000
5.1411	0.730	2.963	0.352	0.000
5.2146	0.735	3.017	0.380	0.000
5.2880	0.740	3.071	0.408	0.000
5.3614	0.744	3.126	0.438	0.000
5.4349	0.749	3.180	0.472	0.000
5.5083	0.754	3.236	0.508	0.000
5.5818	0.758	3.291	0.545	0.000
5.6552	0.763	3.347	0.712	0.000
5.7287	0.768	3.403	1.209	0.000
5.8021	0.772	3.460	1.885	0.000
5.8756	0.777	3.517	2.673	0.000
5.9490	0.782	3.574	3.510	0.000
6.0224	0.786	3.632	4.331	0.000
6.0959	0.791	3.690	5.074	0.000
6.1693	0.796	3.748	5.691	0.000
6.2428	0.801	3.807	6.156	0.000
6.3162	0.805	3.866	6.483	0.000
6.3897	0.810	3.925	6.825	0.000
6.4631	0.815	3.985	7.114	0.000
6.5366	0.820	4.045	7.391	0.000

6.6100	0.825	4.105	7.657	0.000
6.6834	0.829	4.166	7.914	0.000

Analysis Results

POC 1

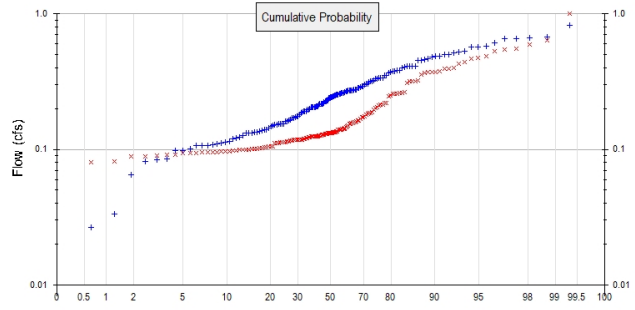
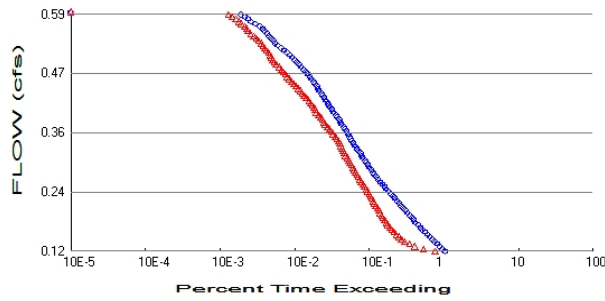

+ Predeveloped x Mitigated

Predeveloped Landuse Totals for POC #1

Total Pervious Area: 10.85
 Total Impervious Area: 0

Mitigated Landuse Totals for POC #1

Total Pervious Area: 4.58
 Total Impervious Area: 6.27

Flow Frequency Method: Log Pearson Type III 17B

Flow Frequency Return Periods for Predeveloped. POC #1

Return Period	Flow(cfs)
2 year	0.24515
5 year	0.377189
10 year	0.453512
25 year	0.536178
50 year	0.589355
100 year	0.635496

Flow Frequency Return Periods for Mitigated. POC #1

Return Period	Flow(cfs)
2 year	0.147056
5 year	0.235866
10 year	0.316346
25 year	0.44896
50 year	0.574798
100 year	0.728218

Annual Peaks

Annual Peaks for Predeveloped and Mitigated. POC #1

Year	Predeveloped	Mitigated
1902	0.199	0.125
1903	0.151	0.104
1904	0.259	0.196
1905	0.126	0.126
1906	0.065	0.080
1907	0.380	0.164
1908	0.274	0.116
1909	0.268	0.116
1910	0.380	0.162
1911	0.246	0.129

1912	0.824	0.372
1913	0.384	0.215
1914	0.098	0.264
1915	0.160	0.131
1916	0.244	0.120
1917	0.083	0.100
1918	0.261	0.317
1919	0.203	0.126
1920	0.250	0.130
1921	0.272	0.146
1922	0.274	0.172
1923	0.217	0.136
1924	0.106	0.102
1925	0.134	0.101
1926	0.238	0.118
1927	0.174	0.114
1928	0.187	0.122
1929	0.379	0.158
1930	0.243	0.118
1931	0.231	0.118
1932	0.176	0.131
1933	0.196	0.126
1934	0.500	0.547
1935	0.230	0.310
1936	0.208	0.123
1937	0.332	0.173
1938	0.204	0.125
1939	0.017	0.082
1940	0.225	0.139
1941	0.136	0.090
1942	0.337	0.487
1943	0.171	0.124
1944	0.352	0.220
1945	0.271	0.124
1946	0.160	0.118
1947	0.113	0.099
1948	0.522	0.156
1949	0.454	0.256
1950	0.132	0.100
1951	0.171	0.104
1952	0.675	0.376
1953	0.613	0.372
1954	0.217	0.133
1955	0.190	0.099
1956	0.100	0.094
1957	0.325	0.144
1958	0.652	0.594
1959	0.408	0.533
1960	0.120	0.098
1961	0.408	0.394
1962	0.221	0.125
1963	0.108	0.094
1964	0.112	0.210
1965	0.458	0.394
1966	0.134	0.112
1967	0.205	0.143
1968	0.216	0.133
1969	0.204	0.111

1970	0.315	0.141
1971	0.483	0.430
1972	0.317	0.322
1973	0.411	0.212
1974	0.226	0.140
1975	0.513	0.556
1976	0.274	0.187
1977	0.122	0.089
1978	0.450	0.366
1979	0.132	0.118
1980	0.263	0.168
1981	0.240	0.132
1982	0.115	0.091
1983	0.409	0.175
1984	0.185	0.141
1985	0.292	0.183
1986	0.244	0.129
1987	0.467	0.356
1988	0.292	0.219
1989	0.268	0.118
1990	0.306	0.128
1991	0.246	0.135
1992	0.319	0.318
1993	0.330	0.132
1994	0.484	0.155
1995	0.110	0.114
1996	0.529	0.465
1997	0.218	0.105
1998	0.261	0.148
1999	0.027	0.094
2000	0.195	0.134
2001	0.106	0.088
2002	0.349	0.259
2003	0.301	0.142
2004	0.266	0.133
2005	0.485	0.261
2006	0.155	0.102
2007	0.163	0.119
2008	0.261	0.124
2009	0.173	0.114
2010	0.150	0.131
2011	0.137	0.096
2012	0.205	0.122
2013	0.154	0.101
2014	0.107	0.097
2015	0.209	0.202
2016	0.085	0.098
2017	0.372	0.186
2018	0.665	0.635
2019	0.658	0.437
2020	0.208	0.150
2021	0.339	0.248
2022	0.140	0.105
2023	0.283	0.128
2024	0.570	0.319
2025	0.254	0.132
2026	0.405	0.162
2027	0.153	0.114

2028	0.133	0.097
2029	0.275	0.153
2030	0.503	0.256
2031	0.166	0.091
2032	0.098	0.095
2033	0.151	0.101
2034	0.148	0.114
2035	0.572	0.996
2036	0.305	0.139
2037	0.081	0.096
2038	0.252	0.160
2039	0.034	0.071
2040	0.144	0.117
2041	0.192	0.105
2042	0.578	0.471
2043	0.277	0.156
2044	0.369	0.251
2045	0.248	0.181
2046	0.289	0.396
2047	0.214	0.133
2048	0.284	0.125
2049	0.253	0.126
2050	0.181	0.112
2051	0.259	0.204
2052	0.154	0.113
2053	0.271	0.374
2054	0.338	0.257
2055	0.140	0.096
2056	0.121	0.095
2057	0.190	0.129
2058	0.226	0.126
2059	0.399	0.186

Ranked Annual Peaks

Ranked Annual Peaks for Predeveloped and Mitigated. POC #1

Rank	Predeveloped	Mitigated
1	0.8243	0.9958
2	0.6753	0.6355
3	0.6653	0.5938
4	0.6575	0.5558
5	0.6522	0.5471
6	0.6131	0.5333
7	0.5784	0.4871
8	0.5724	0.4713
9	0.5696	0.4650
10	0.5287	0.4374
11	0.5218	0.4303
12	0.5126	0.3961
13	0.5025	0.3944
14	0.4998	0.3938
15	0.4853	0.3757
16	0.4840	0.3736
17	0.4829	0.3720
18	0.4670	0.3718
19	0.4583	0.3657
20	0.4536	0.3558
21	0.4505	0.3220
22	0.4110	0.3188

23	0.4086	0.3179
24	0.4084	0.3171
25	0.4079	0.3097
26	0.4045	0.2635
27	0.3991	0.2612
28	0.3840	0.2588
29	0.3802	0.2565
30	0.3795	0.2563
31	0.3791	0.2557
32	0.3720	0.2514
33	0.3685	0.2477
34	0.3524	0.2202
35	0.3493	0.2187
36	0.3389	0.2151
37	0.3378	0.2124
38	0.3374	0.2101
39	0.3316	0.2037
40	0.3295	0.2017
41	0.3247	0.1955
42	0.3194	0.1872
43	0.3172	0.1864
44	0.3152	0.1858
45	0.3063	0.1833
46	0.3048	0.1815
47	0.3007	0.1749
48	0.2922	0.1731
49	0.2918	0.1716
50	0.2890	0.1681
51	0.2841	0.1642
52	0.2835	0.1624
53	0.2767	0.1621
54	0.2746	0.1597
55	0.2744	0.1578
56	0.2739	0.1562
57	0.2736	0.1556
58	0.2720	0.1546
59	0.2714	0.1533
60	0.2710	0.1501
61	0.2685	0.1481
62	0.2677	0.1464
63	0.2658	0.1440
64	0.2627	0.1426
65	0.2613	0.1420
66	0.2612	0.1411
67	0.2611	0.1406
68	0.2588	0.1398
69	0.2588	0.1389
70	0.2541	0.1388
71	0.2529	0.1365
72	0.2517	0.1350
73	0.2496	0.1338
74	0.2483	0.1335
75	0.2461	0.1334
76	0.2455	0.1331
77	0.2444	0.1326
78	0.2436	0.1320
79	0.2428	0.1316
80	0.2399	0.1316

81	0.2380	0.1312
82	0.2310	0.1311
83	0.2303	0.1306
84	0.2265	0.1302
85	0.2264	0.1293
86	0.2245	0.1290
87	0.2214	0.1287
88	0.2177	0.1282
89	0.2175	0.1282
90	0.2165	0.1264
91	0.2156	0.1264
92	0.2140	0.1259
93	0.2089	0.1256
94	0.2077	0.1255
95	0.2077	0.1253
96	0.2054	0.1250
97	0.2052	0.1249
98	0.2042	0.1247
99	0.2039	0.1244
100	0.2034	0.1239
101	0.1987	0.1235
102	0.1955	0.1230
103	0.1950	0.1220
104	0.1919	0.1218
105	0.1903	0.1203
106	0.1900	0.1192
107	0.1871	0.1184
108	0.1854	0.1184
109	0.1809	0.1181
110	0.1764	0.1180
111	0.1741	0.1180
112	0.1730	0.1177
113	0.1708	0.1174
114	0.1707	0.1161
115	0.1659	0.1157
116	0.1633	0.1142
117	0.1603	0.1137
118	0.1603	0.1137
119	0.1546	0.1135
120	0.1541	0.1135
121	0.1537	0.1133
122	0.1533	0.1121
123	0.1512	0.1119
124	0.1512	0.1107
125	0.1505	0.1051
126	0.1477	0.1048
127	0.1438	0.1045
128	0.1398	0.1043
129	0.1395	0.1041
130	0.1369	0.1024
131	0.1362	0.1017
132	0.1338	0.1013
133	0.1338	0.1010
134	0.1328	0.1005
135	0.1324	0.0998
136	0.1317	0.0996
137	0.1257	0.0994
138	0.1221	0.0992

139	0.1213	0.0983
140	0.1199	0.0980
141	0.1148	0.0973
142	0.1131	0.0972
143	0.1119	0.0960
144	0.1103	0.0958
145	0.1079	0.0957
146	0.1068	0.0950
147	0.1065	0.0949
148	0.1060	0.0944
149	0.1003	0.0943
150	0.0983	0.0935
151	0.0979	0.0915
152	0.0853	0.0909
153	0.0834	0.0898
154	0.0814	0.0890
155	0.0653	0.0881
156	0.0335	0.0819
157	0.0265	0.0803
158	0.0171	0.0715

Duration Flows

The Facility PASSED

Flow(cfs)	Predev	Mit	Percentage	Pass/Fail
0.1226	57450	41988	73	Pass
0.1273	52653	29523	56	Pass
0.1320	48354	22675	46	Pass
0.1367	45146	19152	42	Pass
0.1414	41517	16349	39	Pass
0.1461	38321	14847	38	Pass
0.1509	35972	13867	38	Pass
0.1556	33251	12764	38	Pass
0.1603	30648	11795	38	Pass
0.1650	28432	10991	38	Pass
0.1697	26764	10399	38	Pass
0.1744	24914	9762	39	Pass
0.1792	23169	9257	39	Pass
0.1839	21922	8870	40	Pass
0.1886	20493	8421	41	Pass
0.1933	19146	8083	42	Pass
0.1980	17856	7728	43	Pass
0.2027	16881	7457	44	Pass
0.2074	15712	7097	45	Pass
0.2122	14648	6737	45	Pass
0.2169	13872	6493	46	Pass
0.2216	12975	6199	47	Pass
0.2263	12138	5956	49	Pass
0.2310	11385	5740	50	Pass
0.2357	10787	5526	51	Pass
0.2404	10050	5259	52	Pass
0.2452	9374	4995	53	Pass
0.2499	8864	4796	54	Pass
0.2546	8260	4533	54	Pass
0.2593	7751	4296	55	Pass
0.2640	7241	4086	56	Pass
0.2687	6848	3935	57	Pass
0.2735	6449	3784	58	Pass
0.2782	6116	3617	59	Pass
0.2829	5872	3477	59	Pass
0.2876	5584	3309	59	Pass
0.2923	5289	3172	59	Pass
0.2970	5004	3040	60	Pass
0.3017	4817	2929	60	Pass
0.3065	4558	2797	61	Pass
0.3112	4345	2664	61	Pass
0.3159	4190	2565	61	Pass
0.3206	3962	2456	61	Pass
0.3253	3725	2378	63	Pass
0.3300	3536	2301	65	Pass
0.3347	3389	2225	65	Pass
0.3395	3240	2132	65	Pass
0.3442	3092	2031	65	Pass
0.3489	2988	1934	64	Pass
0.3536	2863	1819	63	Pass
0.3583	2743	1708	62	Pass
0.3630	2600	1616	62	Pass
0.3678	2489	1523	61	Pass

0.3725	2370	1424	60	Pass
0.3772	2267	1340	59	Pass
0.3819	2180	1294	59	Pass
0.3866	2068	1240	59	Pass
0.3913	1956	1163	59	Pass
0.3960	1835	1080	58	Pass
0.4008	1755	1048	59	Pass
0.4055	1667	1009	60	Pass
0.4102	1579	952	60	Pass
0.4149	1519	903	59	Pass
0.4196	1454	860	59	Pass
0.4243	1375	796	57	Pass
0.4290	1296	740	57	Pass
0.4338	1249	701	56	Pass
0.4385	1189	657	55	Pass
0.4432	1131	613	54	Pass
0.4479	1092	574	52	Pass
0.4526	1032	533	51	Pass
0.4573	985	498	50	Pass
0.4621	922	470	50	Pass
0.4668	877	442	50	Pass
0.4715	822	417	50	Pass
0.4762	772	387	50	Pass
0.4809	730	368	50	Pass
0.4856	672	342	50	Pass
0.4903	629	313	49	Pass
0.4951	588	294	50	Pass
0.4998	556	280	50	Pass
0.5045	510	270	52	Pass
0.5092	475	256	53	Pass
0.5139	437	247	56	Pass
0.5186	397	231	58	Pass
0.5233	363	219	60	Pass
0.5281	329	208	63	Pass
0.5328	302	196	64	Pass
0.5375	283	181	63	Pass
0.5422	264	170	64	Pass
0.5469	249	157	63	Pass
0.5516	235	142	60	Pass
0.5564	219	130	59	Pass
0.5611	205	125	60	Pass
0.5658	190	119	62	Pass
0.5705	163	107	65	Pass
0.5752	144	99	68	Pass
0.5799	132	90	68	Pass
0.5846	119	80	67	Pass
0.5894	106	71	66	Pass

Water Quality

Water Quality BMP Flow and Volume for POC #1

On-line facility volume: 0 acre-feet

On-line facility target flow: 0 cfs.

Adjusted for 15 min: 0 cfs.

Off-line facility target flow: 0 cfs.

Adjusted for 15 min: 0 cfs.

LID Report

LID Technique	Used for Treatment ?	Total Volume Needs Treatment (ac-ft)	Volume Through Facility (ac-ft)	Infiltration Volume (ac-ft)	Cumulative Volume Infiltration Credit	Percent Volume Infiltrated	Water Quality	Percent Water Quality Treated	Comment
Trapezoidal Pond 1 POC	<input type="checkbox"/>	2841.11			<input type="checkbox"/>	0.00			
Total Volume Infiltrated		2841.11	0.00	0.00		0.00	0.00	0%	No Treat. Credit
Compliance with LID Standard 8% of 2-yr to 50% of 2-yr									Duration Analysis Result = Passed

Model Default Modifications

Total of 0 changes have been made.

PERLND Changes

No PERLND changes have been made.

IMPLND Changes

No IMPLND changes have been made.

Appendix
Predeveloped Schematic

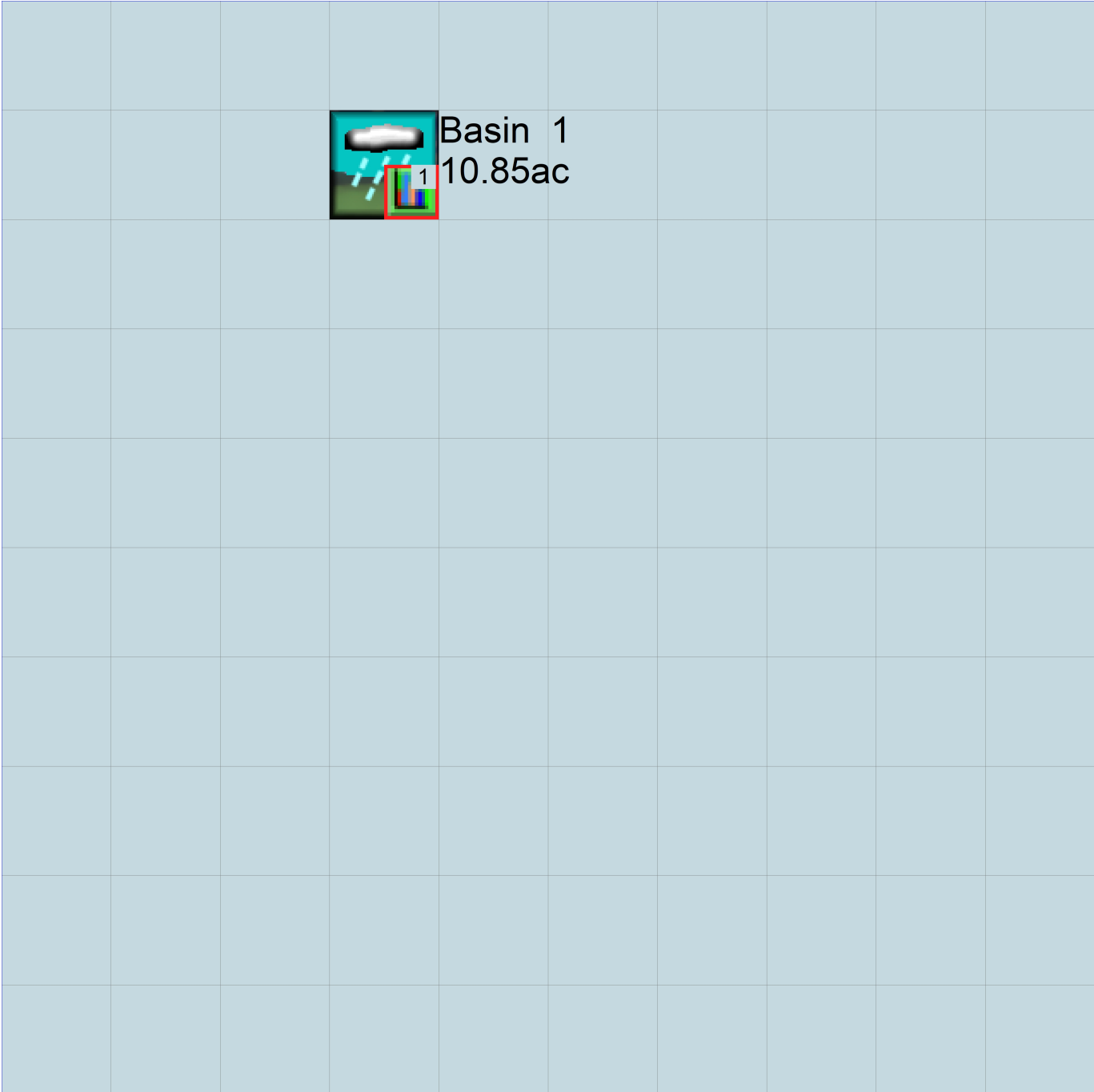

Mitigated Schematic

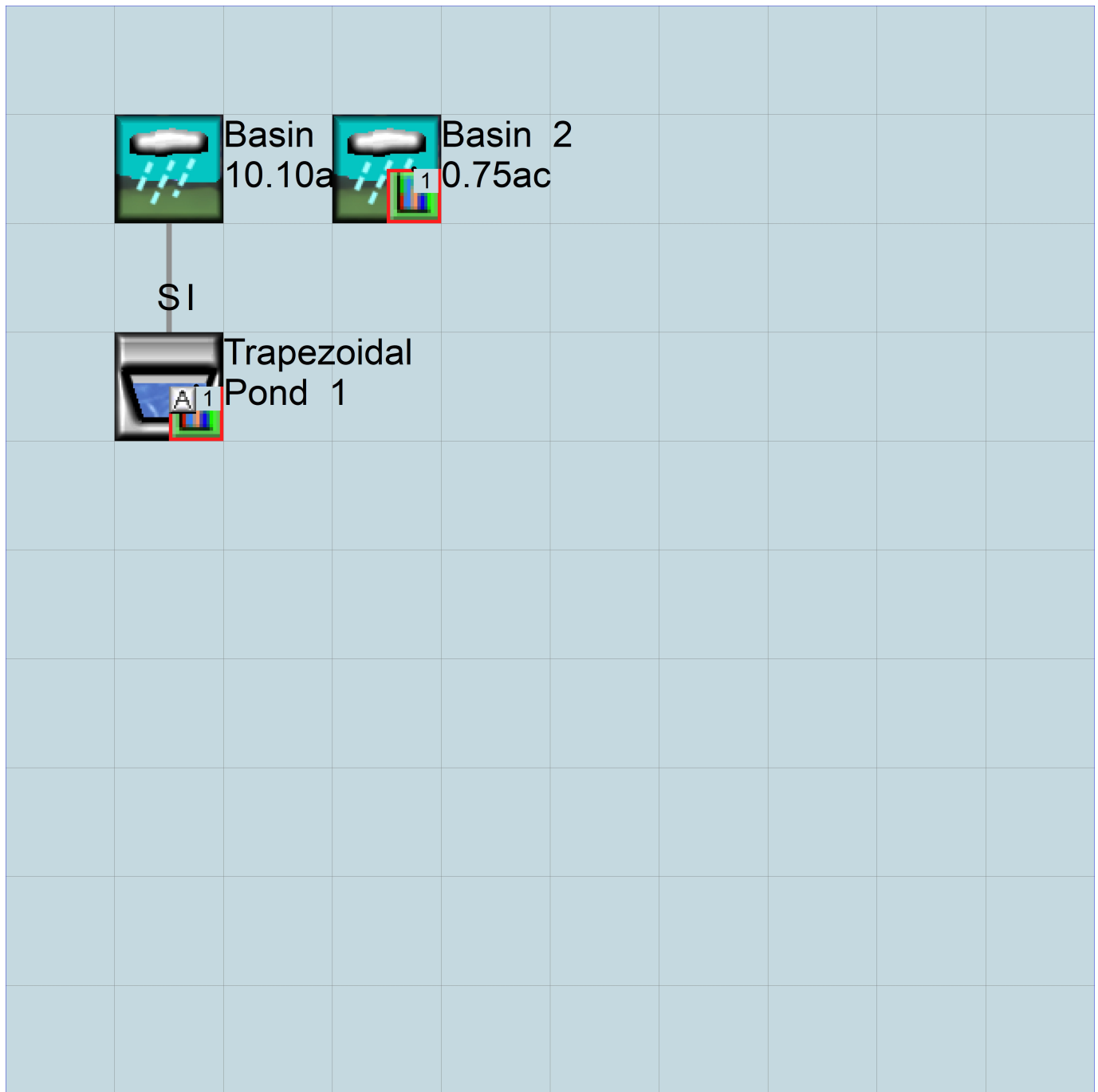

Predeveloped UCI File

RUN

GLOBAL

```
WVHM4 model simulation
START      1901 10 01      END      2059 09 30
RUN INTERP OUTPUT LEVEL   3      0
RESUME     0 RUN          1
UNIT SYSTEM 1
```

END GLOBAL

FILES

```
<File> <Un#> <-----File Name----->***
<-ID->                                     ***
WDM      26      16718-POND.wdm
MESSU    25      Pre16718-POND.MES
          27      Pre16718-POND.L61
          28      Pre16718-POND.L62
          30      POC16718-POND1.dat
```

END FILES

OPN SEQUENCE

```
INGRP          INDELT 00:15
  PERLND        10
  COPY          501
  DISPLY        1
```

END INGRP

END OPN SEQUENCE

DISPLY

DISPLY-INFO1

```
# - #<-----Title----->***TRAN PIVL DIG1 FIL1  PYR DIG2 FIL2 YRND
1      Basin 1          MAX          1      2      30      9
```

END DISPLY-INFO1

END DISPLY

COPY

TIMESERIES

```
# - # NPT NMN ***
1      1      1
501    1      1
```

END TIMESERIES

END COPY

GENER

OPCODE

```
#      # OPCD ***
```

END OPCODE

PARM

```
#      #          K ***
```

END PARM

END GENER

PERLND

GEN-INFO

```
<PLS ><-----Name----->NBLKS  Unit-systems  Printer ***
# - #          User  t-series  Engl Metr ***
          in  out          ***
```

```
10      C, Forest, Flat      1      1      1      1      27      0
```

END GEN-INFO

*** Section PWATER***

ACTIVITY

```
<PLS > ***** Active Sections *****
# - # ATMP SNOW PWAT  SED  PST  PWG  PQAL MSTL PEST NITR PHOS TRAC ***
10      0      0      1      0      0      0      0      0      0      0      0      0
```

END ACTIVITY

PRINT-INFO

```
<PLS > ***** Print-flags ***** PIVL  PYR
# - # ATMP SNOW PWAT  SED  PST  PWG  PQAL MSTL PEST NITR PHOS TRAC *****
10      0      0      4      0      0      0      0      0      0      0      0      0      1      9
```

END PRINT-INFO

```

PWAT-PARM1
<PLS > PWATER variable monthly parameter value flags ***
# - # CSNO RTOP UZFG VCS VUZ VNN VIFW VIRC VLE INFC HWT ***
10 0 0 0 0 0 0 0 0 0 0 0
END PWAT-PARM1

PWAT-PARM2
<PLS > PWATER input info: Part 2 ***
# - # ***FOREST LZSN INFILT LSUR SLSUR KVARY AGWRC
10 0 4.5 0.08 400 0.05 0.5 0.996
END PWAT-PARM2

PWAT-PARM3
<PLS > PWATER input info: Part 3 ***
# - # ***PETMAX PETMIN INFEXP INFILD DEEPFR BASETP AGWETP
10 0 0 2 2 0 0 0
END PWAT-PARM3

PWAT-PARM4
<PLS > PWATER input info: Part 4 ***
# - # CEPSC UZSN NSUR INTFW IRC LZETP ***
10 0.2 0.5 0.35 6 0.5 0.7
END PWAT-PARM4

PWAT-STATE1
<PLS > *** Initial conditions at start of simulation
ran from 1990 to end of 1992 (pat 1-11-95) RUN 21 ***
# - # *** CEPS SURS UZS IFWS LZS AGWS GWVS
10 0 0 0 0 2.5 1 0
END PWAT-STATE1

END PERLND

IMPLND
GEN-INFO
<PLS ><-----Name-----> Unit-systems Printer ***
# - # User t-series Engl Metr ***
in out ***
END GEN-INFO
*** Section IWATER***

ACTIVITY
<PLS > ***** Active Sections *****
# - # ATMP SNOW IWAT SLD IWG IQAL ***
END ACTIVITY

PRINT-INFO
<ILS > ***** Print-flags ***** PIVL PYR
# - # ATMP SNOW IWAT SLD IWG IQAL *****
END PRINT-INFO

IWAT-PARM1
<PLS > IWATER variable monthly parameter value flags ***
# - # CSNO RTOP VRS VNN RTLI ***
END IWAT-PARM1

IWAT-PARM2
<PLS > IWATER input info: Part 2 ***
# - # *** LSUR SLSUR NSUR RETSC
END IWAT-PARM2

IWAT-PARM3
<PLS > IWATER input info: Part 3 ***
# - # ***PETMAX PETMIN
END IWAT-PARM3

IWAT-STATE1
<PLS > *** Initial conditions at start of simulation
# - # *** RETS SURS
END IWAT-STATE1

```

END IMPLND

SCHEMATIC

<-Source->	<Name> #	<--Area-->	<-factor-->	<-Target->	<Name> #	MBLK	Tbl#	***
Basin	1***							
PERLND	10	10.85		COPY	501	12		
PERLND	10	10.85		COPY	501	13		

*****Routing*****
END SCHEMATIC

NETWORK

<-Volume->	<-Grp>	<-Member->	<--Mult-->	Tran	<-Target vols>	<-Grp>	<-Member->	***	
<Name> #		<Name> #	#	<-factor-->strg	<Name> #	#	<Name> #	***	
COPY	501	OUTPUT	MEAN	1 1	48.4	DISPLY	1	INPUT	TIMSER 1

<-Volume->	<-Grp>	<-Member->	<--Mult-->	Tran	<-Target vols>	<-Grp>	<-Member->	***
<Name> #		<Name> #	#	<-factor-->strg	<Name> #	#	<Name> #	***

END NETWORK

RCHRES

GEN-INFO	RCHRES	Name	Nexits	Unit	Systems	Printer	***
# - #	<----->	<----->	User	T-series	Engl	Metr	LKFG
			in	out			***

END GEN-INFO
*** Section RCHRES***

ACTIVITY

<PLS > ***** Active Sections *****

#	-	#	HYFG	ADFG	CNFG	HTFG	SDFG	GQFG	OXFG	NUFG	PKFG	PHFG	***

END ACTIVITY

PRINT-INFO

<PLS > ***** Print-flags ***** PIVL PYR

#	-	#	HYDR	ADCA	CONS	HEAT	SED	GQL	OXRX	NUTR	PLNK	PHCB	PIVL	PYR	*****

END PRINT-INFO

HYDR-PARM1

RCHRES	Flags	for each	HYDR	Section	***	ODGTFG	for each	FUNCT	for each	***	
# - #	VC	A1	A2	A3	ODFVFG	for each	***	ODGTFG	for each	FUNCT	for each
	FG	FG	FG	FG	possible	exit	***	possible	exit	possible	exit
	*	*	*	*	*	*	*	*	*	*	*

END HYDR-PARM1

HYDR-PARM2

#	-	#	FTABNO	LEN	DELTH	STCOR	KS	DB50	***
<----->			<----->	<----->	<----->	<----->	<----->	<----->	***

END HYDR-PARM2

HYDR-INIT

RCHRES	Initial	conditions	for each	HYDR	section	***
# - #	***	VOL	Initial	value	of COLIND	Initial
	***	ac-ft	for each	possible	exit	for each
						possible
						exit

<-----><-----> <-----><-----><-----><-----><-----> *** <-----><-----><-----><-----><----->

END HYDR-INIT

END RCHRES

SPEC-ACTIONS

END SPEC-ACTIONS

FTABLES

END FTABLES

EXT SOURCES

<-Volume->	<Member>	SsysSgap	<--Mult-->	Tran	<-Target vols>	<-Grp>	<-Member->	***	
<Name> #	<Name> #	tem	strg	<-factor-->strg	<Name> #	#	<Name> #	***	
WDM	2	PREC	ENGL	1	PERLND	1	999	EXTNL	PREC
WDM	2	PREC	ENGL	1	IMPLND	1	999	EXTNL	PREC

```
WDM      1 EVAP      ENGL      1          PERLND    1 999 EXTNL  PETINP
WDM      1 EVAP      ENGL      1          IMPLND    1 999 EXTNL  PETINP
```

END EXT SOURCES

EXT TARGETS

```
<-Volume-> <-Grp> <-Member-><--Mult-->Tran <-Volume-> <Member> Tsys Tgap Amd ***
<Name>      #      <Name> # #<-factor->strg <Name>      # <Name>      tem strg strg***
COPY  501 OUTPUT MEAN  1 1      48.4      WDM  501 FLOW      ENGL      REPL
END EXT TARGETS
```

MASS-LINK

```
<Volume>   <-Grp> <-Member-><--Mult-->   <Target>           <-Grp> <-Member->***
<Name>     #      <Name> # #<-factor->   <Name>           <Name> # #***
  MASS-LINK 12
PERLND     PWATER SURO           0.083333      COPY           INPUT  MEAN
  END MASS-LINK 12
```

```
  MASS-LINK 13
PERLND     PWATER IFWO           0.083333      COPY           INPUT  MEAN
  END MASS-LINK 13
```

END MASS-LINK

END RUN

Mitigated UCI File

RUN

GLOBAL

WVHM4 model simulation
START 1901 10 01 END 2059 09 30
RUN INTERP OUTPUT LEVEL 3 0
RESUME 0 RUN 1 UNIT SYSTEM 1

END GLOBAL

FILES

```
<File> <Un#> <-----File Name----->***  
<-ID-> ***  
WDM 26 16718-POND.wdm  
MESSU 25 Mit16718-POND.MES  
27 Mit16718-POND.L61  
28 Mit16718-POND.L62  
30 POC16718-POND1.dat
```

END FILES

OPN SEQUENCE

INGRP INDELT 00:15
PERLND 13
IMPLND 4
IMPLND 11
IMPLND 14
PERLND 16
RCHRES 1
COPY 1
COPY 501
COPY 601
DISPLY 1

END INGRP

END OPN SEQUENCE

DISPLY

DISPLY-INFO1

```
# - #<-----Title----->***TRAN PIVL DIG1 FIL1 PYR DIG2 FIL2 YRND  
1 Trapezoidal Pond 1 MAX 1 2 30 9
```

END DISPLY-INFO1

END DISPLY

COPY

TIMESERIES

```
# - # NPT NMN ***  
1 1 1  
501 1 1  
601 1 1
```

END TIMESERIES

END COPY

GENER

OPCODE

```
# # OPCD ***
```

END OPCODE

PARM

```
# # K ***
```

END PARM

END GENER

PERLND

GEN-INFO

```
<PLS ><-----Name----->NBLKS Unit-systems Printer ***  
# - # User t-series Engl Metr ***  
in out ***  
13 C, Pasture, Flat 1 1 1 1 27 0  
16 C, Lawn, Flat 1 1 1 1 27 0
```

END GEN-INFO

*** Section PWATER***

ACTIVITY

```
<PLS > ***** Active Sections *****  
# - # ATMP SNOW PWAT SED PST PWG PQAL MSTL PEST NITR PHOS TRAC ***
```

```

13      0  0  1  0  0  0  0  0  0  0  0  0
16      0  0  1  0  0  0  0  0  0  0  0  0
END ACTIVITY

```

PRINT-INFO

```

<PLS > ***** Print-flags ***** PIVL  PYR
# - # ATMP SNOW PWAT  SED  PST  PWG  PQAL MSTL PEST NITR PHOS TRAC  *****
13      0  0  4  0  0  0  0  0  0  0  0  0  1  9
16      0  0  4  0  0  0  0  0  0  0  0  0  1  9
END PRINT-INFO

```

PWAT-PARM1

```

<PLS > PWATER variable monthly parameter value flags ***
# - # CSNO RTOP UZFG  VCS  VUZ  VNN VIFW VIRC  VLE INFC  HWT ***
13      0  0  0  0  0  0  0  0  0  0  0
16      0  0  0  0  0  0  0  0  0  0  0
END PWAT-PARM1

```

PWAT-PARM2

```

<PLS > PWATER input info: Part 2          ***
# - # ***FOREST  LZSN  INFILT  LSUR  SLSUR  KVARY  AGWRC
13      0  4.5  0.06  400  0.05  0.5  0.996
16      0  4.5  0.03  400  0.05  0.5  0.996
END PWAT-PARM2

```

PWAT-PARM3

```

<PLS > PWATER input info: Part 3          ***
# - # ***PETMAX  PETMIN  INFEXP  INFILD  DEEPFR  BASETP  AGWETP
13      0  0  2  2  0  0  0
16      0  0  2  2  0  0  0
END PWAT-PARM3

```

PWAT-PARM4

```

<PLS > PWATER input info: Part 4          ***
# - # CEPSC  UZSN  NSUR  INTFW  IRC  LZETP ***
13      0.15  0.4  0.3  6  0.5  0.4
16      0.1  0.25  0.25  6  0.5  0.25
END PWAT-PARM4

```

PWAT-STATE1

```

<PLS > *** Initial conditions at start of simulation
          ran from 1990 to end of 1992 (pat 1-11-95) RUN 21 ***
# - # *** CEPS  SURS  UZS  IFWS  LZS  AGWS  GWVS
13      0  0  0  0  2.5  1  0
16      0  0  0  0  2.5  1  0
END PWAT-STATE1

```

END PERLND

IMPLND

GEN-INFO

```

<PLS ><-----Name----->  Unit-systems  Printer ***
# - #  User  t-series  Engr Metr ***
          in  out  ***
4      ROOF TOPS/FLAT  1  1  1  27  0
11     PARKING/FLAT  1  1  1  27  0
14     POND  1  1  1  27  0
END GEN-INFO
*** Section IWATER***

```

ACTIVITY

```

<PLS > ***** Active Sections *****
# - # ATMP SNOW IWAT  SLD  IWG IQAL  ***
4      0  0  1  0  0  0
11     0  0  1  0  0  0
14     0  0  1  0  0  0
END ACTIVITY

```

PRINT-INFO

```

<ILS > ***** Print-flags ***** PIVL  PYR
# - # ATMP SNOW IWAT  SLD  IWG IQAL  *****

```

```

4      0  0  4  0  0  0  1  9
11     0  0  4  0  0  0  1  9
14     0  0  4  0  0  0  1  9
END PRINT-INFO

```

```

IWAT-PARM1
<PLS > IWATER variable monthly parameter value flags ***
# - # CSNO RTOP VRS VNN RTLI ***
4      0  0  0  0  0
11     0  0  0  0  0
14     0  0  0  0  0
END IWAT-PARM1

```

```

IWAT-PARM2
<PLS > IWATER input info: Part 2 ***
# - # *** LSUR SLSUR NSUR RETSC
4      400  0.01  0.1  0.1
11     400  0.01  0.1  0.1
14     400  0.01  0.1  0.1
END IWAT-PARM2

```

```

IWAT-PARM3
<PLS > IWATER input info: Part 3 ***
# - # ***PETMAX PETMIN
4      0  0
11     0  0
14     0  0
END IWAT-PARM3

```

```

IWAT-STATE1
<PLS > *** Initial conditions at start of simulation
# - # *** RETS SURS
4      0  0
11     0  0
14     0  0
END IWAT-STATE1

```

END IMPLND

```

SCHEMATIC
<-Source->          <--Area-->          <-Target->          MBLK          ***
<Name> #           <-factor-->          <Name> #          Tbl#          ***
Basin 1***
PERLND 13           3.83           RCHRES 1          2
PERLND 13           3.83           RCHRES 1          3
IMPLND 4            2.55           RCHRES 1          5
IMPLND 11           3.26           RCHRES 1          5
IMPLND 14           0.46           RCHRES 1          5
Basin 2***
PERLND 16           0.75           COPY 501          12
PERLND 16           0.75           COPY 601          12
PERLND 16           0.75           COPY 501          13
PERLND 16           0.75           COPY 601          13

```

```

*****Routing*****
PERLND 13           3.83           COPY 1            12
IMPLND 4            2.55           COPY 1            15
IMPLND 11           3.26           COPY 1            15
IMPLND 14           0.46           COPY 1            15
PERLND 13           3.83           COPY 1            13
RCHRES 1            1             COPY 501          16
END SCHEMATIC

```

```

NETWORK
<-Volume-> <-Grp> <-Member-><--Mult-->Tran <-Target vols> <-Grp> <-Member-> ***
<Name> #   <Name> # #<-factor-->strg <Name> # # <Name> # # ***
COPY 501 OUTPUT MEAN 1 1 48.4 DISPLY 1 INPUT TIMSER 1

```

```

<-Volume-> <-Grp> <-Member-><--Mult-->Tran <-Target vols> <-Grp> <-Member-> ***
<Name> # <Name> # #<-factor->strg <Name> # # <Name> # # ***
END NETWORK

```

RCHRES

```

GEN-INFO
RCHRES      Name      Nexits  Unit Systems  Printer      ***
# - #<-----><----> User T-series  Engl Metr LKFG      ***
              in  out
1      Trapezoidal Pond-005      1      1      1      1      28      0      1
END GEN-INFO
*** Section RCHRES***

```

ACTIVITY

```

<PLS > ***** Active Sections *****
# - # HYFG ADFG CNFG HTFG SDFG GQFG OXFG NUFG PKFG PHFG ***
1      1      0      0      0      0      0      0      0      0      0
END ACTIVITY

```

PRINT-INFO

```

<PLS > ***** Print-flags ***** PIVL  PYR
# - # HYDR ADCA CONS HEAT  SED  GOL  OXRX NUTR  PLNK PHCB  PIVL  PYR  *****
1      4      0      0      0      0      0      0      0      0      0      1      9
END PRINT-INFO

```

HYDR-PARM1

```

RCHRES  Flags for each HYDR Section      ***
# - # VC A1 A2 A3  ODFVFG for each *** ODGTFG for each  FUNCT for each
      FG FG FG FG  possible exit *** possible exit  possible exit
      * * * * * * * * * * * * * * * * * * * * * * * * * * * * * * * * * *
1      0 1 0 0      4 0 0 0 0      0 0 0 0 0      2 2 2 2 2
END HYDR-PARM1

```

HYDR-PARM2

```

# - # FTABNO      LEN      DELTH      STCOR      KS      DB50      ***
<---><-----><-----><-----><-----><----->
1      1      0.01      0.0      0.0      0.5      0.0
END HYDR-PARM2

```

HYDR-INIT

```

RCHRES  Initial conditions for each HYDR section      ***
# - # *** VOL      Initial value of COLIND      Initial value of OUTDGT
      *** ac-ft      for each possible exit      for each possible exit
<---><-----> <---><---><---><---> *** <---><---><---><---><--->
1      0      4.0 0.0 0.0 0.0 0.0      0.0 0.0 0.0 0.0 0.0
END HYDR-INIT
END RCHRES

```

SPEC-ACTIONS

END SPEC-ACTIONS

FTABLES

```

FTABLE      1
91      4
Depth      Area      Volume  Outflow1 Velocity  Travel Time***
(ft)      (acres) (acre-ft) (cfs) (ft/sec) (Minutes)***
0.000000  0.429293  0.000000  0.000000
0.073444  0.433293  0.031676  0.015462
0.146889  0.437303  0.063646  0.021867
0.220333  0.441321  0.095911  0.026781
0.293778  0.445348  0.128472  0.030925
0.367222  0.449384  0.161328  0.034575
0.440667  0.453429  0.194482  0.037875
0.514111  0.457483  0.227932  0.040909
0.587556  0.461546  0.261681  0.043734
0.661000  0.465618  0.295729  0.046387
0.734444  0.469698  0.330075  0.048896
0.807889  0.473788  0.364722  0.051283
0.881333  0.477886  0.399670  0.053563
0.954778  0.481994  0.434919  0.055750
1.028222  0.486110  0.470470  0.057855
1.101667  0.490235  0.506323  0.059885

```

1.175111	0.494369	0.542480	0.061849
1.248556	0.498512	0.578941	0.063753
1.322000	0.502664	0.615706	0.065601
1.395444	0.506825	0.652777	0.067399
1.468889	0.510995	0.690154	0.069150
1.542333	0.515174	0.727837	0.070857
1.615778	0.519361	0.765827	0.072525
1.689222	0.523558	0.804126	0.074155
1.762667	0.527763	0.842733	0.075750
1.836111	0.531978	0.881649	0.077312
1.909556	0.536201	0.920875	0.078843
1.983000	0.540433	0.960411	0.080344
2.056444	0.544674	1.000258	0.081819
2.129889	0.548924	1.040418	0.083267
2.203333	0.553183	1.080890	0.084691
2.276778	0.557451	1.121675	0.086090
2.350222	0.561728	1.162773	0.087468
2.423667	0.566014	1.204187	0.088824
2.497111	0.570308	1.245915	0.090160
2.570556	0.574612	1.287959	0.091476
2.644000	0.578924	1.330319	0.092774
2.717444	0.583246	1.372997	0.094054
2.790889	0.587576	1.415992	0.095316
2.864333	0.591915	1.459306	0.096562
2.937778	0.596263	1.502938	0.097792
3.011222	0.600620	1.546890	0.099007
3.084667	0.604986	1.591163	0.100207
3.158111	0.609361	1.635756	0.101393
3.231556	0.613745	1.680672	0.102565
3.305000	0.618138	1.725909	0.103724
3.378444	0.622539	1.771469	0.104870
3.451889	0.626950	1.817354	0.106004
3.525333	0.631369	1.863562	0.107126
3.598778	0.635798	1.910095	0.108236
3.672222	0.640235	1.956954	0.109335
3.745667	0.644681	2.004139	0.110423
3.819111	0.649136	2.051651	0.111500
3.892556	0.653600	2.099490	0.112567
3.966000	0.658073	2.147657	0.113624
4.039444	0.662555	2.196154	0.114672
4.112889	0.667046	2.244980	0.115709
4.186333	0.671546	2.294136	0.116738
4.259778	0.676054	2.343623	0.117757
4.333222	0.680572	2.393441	0.118768
4.406667	0.685098	2.443591	0.126330
4.480111	0.689633	2.494075	0.140004
4.553556	0.694178	2.544891	0.157147
4.627000	0.698731	2.596042	0.176836
4.700444	0.703293	2.647527	0.198507
4.773889	0.707864	2.699348	0.221761
4.847333	0.712444	2.751505	0.246290
4.920778	0.717033	2.803999	0.271843
4.994222	0.721631	2.856830	0.298208
5.067667	0.726237	2.909998	0.325204
5.141111	0.730853	2.963506	0.352667
5.214556	0.735477	3.017353	0.380453
5.288000	0.740111	3.071540	0.408430
5.361444	0.744753	3.126067	0.438274
5.434889	0.749404	3.180936	0.472716
5.508333	0.754065	3.236147	0.508295
5.581778	0.758734	3.291700	0.544974
5.655222	0.763412	3.347597	0.712895
5.728667	0.768099	3.403837	1.209236
5.802111	0.772794	3.460422	1.885802
5.875556	0.777499	3.517352	2.673895
5.949000	0.782213	3.574629	3.510652
6.022444	0.786935	3.632251	4.331519
6.095889	0.791667	3.690221	5.074860
6.169333	0.796407	3.748539	5.691327
6.242778	0.801157	3.807205	6.156171

```

6.316222 0.805915 3.866220 6.483798
6.389667 0.810682 3.925585 6.825877
6.463111 0.815458 3.985300 7.114797
6.536556 0.820243 4.045367 7.391555
6.610000 0.825037 4.105785 7.657573
END FTABLE 1
END FTABLES

```

EXT SOURCES

```

<-Volume-> <Member> SsysSgap<--Mult-->Tran <-Target vols> <-Grp> <-Member-> ***
<Name> # <Name> # tem strg<-factor->strg <Name> # # <Name> # # ***
WDM 2 PREC ENGL 1 PERLND 1 999 EXTNL PREC
WDM 2 PREC ENGL 1 IMPLND 1 999 EXTNL PREC
WDM 1 EVAP ENGL 1 PERLND 1 999 EXTNL PETINP
WDM 1 EVAP ENGL 1 IMPLND 1 999 EXTNL PETINP

```

END EXT SOURCES

EXT TARGETS

```

<-Volume-> <-Grp> <-Member-><--Mult-->Tran <-Volume-> <Member> Tsys Tgap Amd ***
<Name> # <Name> # #<-factor->strg <Name> # <Name> tem strg strg***
RCHRES 1 HYDR RO 1 1 1 WDM 1000 FLOW ENGL REPL
RCHRES 1 HYDR STAGE 1 1 1 WDM 1001 STAG ENGL REPL
COPY 1 OUTPUT MEAN 1 1 48.4 WDM 701 FLOW ENGL REPL
COPY 501 OUTPUT MEAN 1 1 48.4 WDM 801 FLOW ENGL REPL
COPY 601 OUTPUT MEAN 1 1 48.4 WDM 901 FLOW ENGL REPL

```

END EXT TARGETS

MASS-LINK

```

<Volume> <-Grp> <-Member-><--Mult--> <Target> <-Grp> <-Member->***
<Name> # <Name> # #<-factor-> <Name> <Name> # #***
MASS-LINK 2
PERLND PWATER SURO 0.083333 RCHRES INFLOW IVOL
END MASS-LINK 2

MASS-LINK 3
PERLND PWATER IFWO 0.083333 RCHRES INFLOW IVOL
END MASS-LINK 3

MASS-LINK 5
IMPLND IWATER SURO 0.083333 RCHRES INFLOW IVOL
END MASS-LINK 5

MASS-LINK 12
PERLND PWATER SURO 0.083333 COPY INPUT MEAN
END MASS-LINK 12

MASS-LINK 13
PERLND PWATER IFWO 0.083333 COPY INPUT MEAN
END MASS-LINK 13

MASS-LINK 15
IMPLND IWATER SURO 0.083333 COPY INPUT MEAN
END MASS-LINK 15

MASS-LINK 16
RCHRES ROFLOW COPY INPUT MEAN
END MASS-LINK 16

```

END MASS-LINK

END RUN

Predeveloped HSPF Message File

Mitigated HSPF Message File

Disclaimer

Legal Notice

This program and accompanying documentation are provided 'as-is' without warranty of any kind. The entire risk regarding the performance and results of this program is assumed by End User. Clear Creek Solutions Inc. and the governmental licensee or sublicensees disclaim all warranties, either expressed or implied, including but not limited to implied warranties of program and accompanying documentation. In no event shall Clear Creek Solutions Inc. be liable for any damages whatsoever (including without limitation to damages for loss of business profits, loss of business information, business interruption, and the like) arising out of the use of, or inability to use this program even if Clear Creek Solutions Inc. or their authorized representatives have been advised of the possibility of such damages. Software Copyright © by : Clear Creek Solutions, Inc. 2005-2024; All Rights Reserved.

Clear Creek Solutions, Inc.
6200 Capitol Blvd. Ste F
Olympia, WA. 98501
Toll Free 1(866)943-0304
Local (360)943-0304

www.clearcreeksolutions.com

WWHM2012
PROJECT REPORT

General Model Information

Project Name: 16718_WQ SIZING
Site Name:
Site Address:
City:
Report Date: 5/15/2024
Gage:
Data Start: 10/01/1901
Data End: 09/30/2059
Timestep: 15 Minute
Precip Scale: 1.000
Version Date: 2021/08/18
Version: 4.2.18

POC Thresholds

Low Flow Threshold for POC1:	50 Percent of the 2 Year
High Flow Threshold for POC1:	50 Year

Landuse Basin Data
Predeveloped Land Use

Basin 1

Bypass:	No
GroundWater:	No
Pervious Land Use C, Forest, Flat	acre 0.19
Pervious Total	0.19
Impervious Land Use	acre
Impervious Total	0
Basin Total	0.19

Element Flows To:		
Surface	Interflow	Groundwater

Mitigated Land Use

Basin 1

Bypass:	No
GroundWater:	No
Pervious Land Use	acre
Pervious Total	0
Impervious Land Use	acre
DRIVEWAYS FLAT	0.19
Impervious Total	0.19
Basin Total	0.19

Element Flows To:		
Surface	Interflow	Groundwater

Analysis Results

POC 1

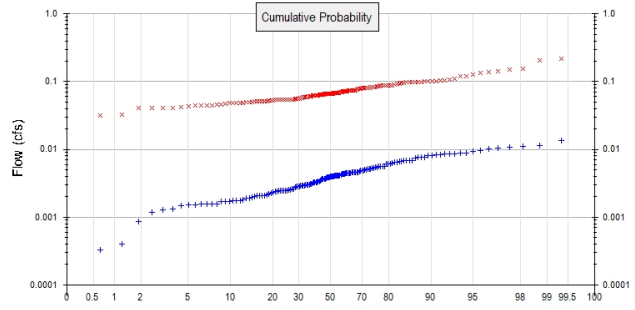
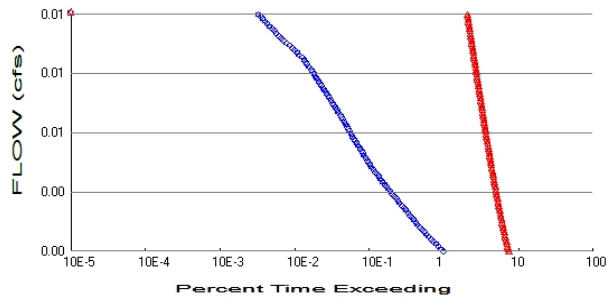

+ Predeveloped x Mitigated

Predeveloped Landuse Totals for POC #1

Total Pervious Area: 0.19
 Total Impervious Area: 0

Mitigated Landuse Totals for POC #1

Total Pervious Area: 0
 Total Impervious Area: 0.19

Flow Frequency Method: Log Pearson Type III 17B

Flow Frequency Return Periods for Predeveloped. POC #1

Return Period	Flow(cfs)
2 year	0.004004
5 year	0.006229
10 year	0.007438
25 year	0.008668
50 year	0.0094
100 year	0.010001

Flow Frequency Return Periods for Mitigated. POC #1

Return Period	Flow(cfs)
2 year	0.066586
5 year	0.08938
10 year	0.105946
25 year	0.12862
50 year	0.146818
100 year	0.166171

Annual Peaks

Annual Peaks for Predeveloped and Mitigated. POC #1

Year	Predeveloped	Mitigated
1902	0.003	0.079
1903	0.002	0.087
1904	0.004	0.099
1905	0.002	0.044
1906	0.001	0.050
1907	0.006	0.066
1908	0.005	0.054
1909	0.005	0.067
1910	0.006	0.064
1911	0.004	0.072

1912	0.013	0.119
1913	0.006	0.052
1914	0.002	0.218
1915	0.003	0.045
1916	0.004	0.084
1917	0.001	0.032
1918	0.004	0.067
1919	0.003	0.041
1920	0.004	0.055
1921	0.005	0.047
1922	0.005	0.074
1923	0.004	0.051
1924	0.002	0.097
1925	0.002	0.040
1926	0.004	0.079
1927	0.003	0.064
1928	0.003	0.048
1929	0.006	0.095
1930	0.004	0.100
1931	0.004	0.048
1932	0.003	0.052
1933	0.003	0.051
1934	0.008	0.084
1935	0.004	0.044
1936	0.003	0.062
1937	0.005	0.092
1938	0.003	0.045
1939	0.000	0.057
1940	0.004	0.100
1941	0.002	0.099
1942	0.005	0.074
1943	0.003	0.074
1944	0.005	0.106
1945	0.005	0.080
1946	0.002	0.062
1947	0.002	0.049
1948	0.009	0.067
1949	0.007	0.103
1950	0.002	0.058
1951	0.003	0.088
1952	0.011	0.099
1953	0.010	0.092
1954	0.004	0.054
1955	0.003	0.050
1956	0.001	0.050
1957	0.005	0.054
1958	0.011	0.067
1959	0.007	0.067
1960	0.002	0.053
1961	0.007	0.151
1962	0.004	0.065
1963	0.002	0.048
1964	0.002	0.140
1965	0.008	0.063
1966	0.002	0.053
1967	0.003	0.074
1968	0.003	0.062
1969	0.003	0.056

1970	0.005	0.064
1971	0.008	0.062
1972	0.005	0.204
1973	0.007	0.118
1974	0.004	0.086
1975	0.009	0.088
1976	0.005	0.094
1977	0.002	0.041
1978	0.008	0.068
1979	0.002	0.072
1980	0.004	0.071
1981	0.004	0.067
1982	0.002	0.054
1983	0.007	0.074
1984	0.003	0.073
1985	0.004	0.083
1986	0.004	0.042
1987	0.008	0.074
1988	0.005	0.044
1989	0.004	0.041
1990	0.005	0.054
1991	0.004	0.080
1992	0.006	0.076
1993	0.005	0.087
1994	0.008	0.059
1995	0.002	0.046
1996	0.009	0.062
1997	0.003	0.056
1998	0.004	0.066
1999	0.000	0.072
2000	0.003	0.063
2001	0.002	0.051
2002	0.006	0.092
2003	0.005	0.054
2004	0.004	0.080
2005	0.008	0.154
2006	0.002	0.072
2007	0.002	0.081
2008	0.004	0.066
2009	0.003	0.051
2010	0.002	0.065
2011	0.002	0.068
2012	0.003	0.064
2013	0.002	0.060
2014	0.002	0.058
2015	0.003	0.097
2016	0.001	0.061
2017	0.006	0.098
2018	0.011	0.059
2019	0.010	0.087
2020	0.003	0.071
2021	0.006	0.060
2022	0.002	0.102
2023	0.005	0.126
2024	0.009	0.134
2025	0.004	0.065
2026	0.007	0.072
2027	0.002	0.080

2028	0.002	0.031
2029	0.005	0.051
2030	0.008	0.103
2031	0.003	0.032
2032	0.002	0.055
2033	0.002	0.069
2034	0.002	0.054
2035	0.010	0.066
2036	0.005	0.054
2037	0.001	0.073
2038	0.004	0.069
2039	0.000	0.138
2040	0.002	0.054
2041	0.003	0.069
2042	0.009	0.079
2043	0.004	0.088
2044	0.006	0.060
2045	0.004	0.049
2046	0.005	0.054
2047	0.004	0.067
2048	0.005	0.055
2049	0.004	0.082
2050	0.003	0.061
2051	0.004	0.086
2052	0.002	0.065
2053	0.004	0.056
2054	0.006	0.110
2055	0.002	0.068
2056	0.002	0.087
2057	0.003	0.043
2058	0.004	0.082
2059	0.007	0.102

Ranked Annual Peaks

Ranked Annual Peaks for Predeveloped and Mitigated. POC #1

Rank	Predeveloped	Mitigated
1	0.0133	0.2185
2	0.0112	0.2040
3	0.0112	0.1535
4	0.0108	0.1513
5	0.0105	0.1401
6	0.0101	0.1383
7	0.0096	0.1343
8	0.0093	0.1256
9	0.0088	0.1194
10	0.0088	0.1185
11	0.0086	0.1104
12	0.0085	0.1058
13	0.0085	0.1032
14	0.0084	0.1031
15	0.0082	0.1024
16	0.0081	0.1016
17	0.0080	0.1000
18	0.0076	0.0997
19	0.0076	0.0989
20	0.0075	0.0988
21	0.0074	0.0988
22	0.0068	0.0977

23	0.0067	0.0974
24	0.0067	0.0969
25	0.0067	0.0952
26	0.0067	0.0944
27	0.0067	0.0922
28	0.0064	0.0918
29	0.0064	0.0915
30	0.0062	0.0885
31	0.0062	0.0882
32	0.0061	0.0877
33	0.0061	0.0873
34	0.0056	0.0872
35	0.0056	0.0869
36	0.0056	0.0866
37	0.0055	0.0857
38	0.0055	0.0857
39	0.0054	0.0838
40	0.0054	0.0835
41	0.0053	0.0833
42	0.0052	0.0821
43	0.0052	0.0816
44	0.0052	0.0806
45	0.0050	0.0804
46	0.0049	0.0802
47	0.0049	0.0801
48	0.0048	0.0800
49	0.0048	0.0793
50	0.0047	0.0790
51	0.0046	0.0787
52	0.0046	0.0761
53	0.0046	0.0743
54	0.0046	0.0743
55	0.0046	0.0737
56	0.0046	0.0737
57	0.0045	0.0736
58	0.0045	0.0735
59	0.0045	0.0732
60	0.0045	0.0725
61	0.0045	0.0721
62	0.0044	0.0720
63	0.0044	0.0718
64	0.0043	0.0718
65	0.0043	0.0717
66	0.0043	0.0709
67	0.0043	0.0708
68	0.0041	0.0690
69	0.0041	0.0688
70	0.0041	0.0687
71	0.0041	0.0684
72	0.0041	0.0683
73	0.0041	0.0676
74	0.0040	0.0672
75	0.0040	0.0671
76	0.0040	0.0668
77	0.0040	0.0667
78	0.0040	0.0667
79	0.0040	0.0667
80	0.0039	0.0667

81	0.0039	0.0665
82	0.0039	0.0664
83	0.0038	0.0663
84	0.0038	0.0660
85	0.0037	0.0654
86	0.0037	0.0654
87	0.0036	0.0651
88	0.0036	0.0650
89	0.0036	0.0643
90	0.0036	0.0642
91	0.0034	0.0637
92	0.0034	0.0635
93	0.0034	0.0630
94	0.0033	0.0628
95	0.0033	0.0622
96	0.0033	0.0621
97	0.0032	0.0620
98	0.0032	0.0619
99	0.0032	0.0617
100	0.0031	0.0609
101	0.0031	0.0608
102	0.0030	0.0602
103	0.0030	0.0599
104	0.0030	0.0598
105	0.0030	0.0595
106	0.0030	0.0585
107	0.0029	0.0583
108	0.0029	0.0580
109	0.0029	0.0567
110	0.0029	0.0560
111	0.0028	0.0556
112	0.0028	0.0555
113	0.0027	0.0550
114	0.0026	0.0549
115	0.0026	0.0546
116	0.0025	0.0545
117	0.0025	0.0543
118	0.0025	0.0542
119	0.0025	0.0541
120	0.0025	0.0541
121	0.0025	0.0540
122	0.0024	0.0539
123	0.0024	0.0537
124	0.0024	0.0536
125	0.0024	0.0535
126	0.0023	0.0530
127	0.0023	0.0526
128	0.0022	0.0520
129	0.0021	0.0519
130	0.0021	0.0515
131	0.0021	0.0514
132	0.0021	0.0512
133	0.0021	0.0507
134	0.0020	0.0506
135	0.0019	0.0504
136	0.0019	0.0497
137	0.0019	0.0495
138	0.0018	0.0487

139	0.0017	0.0485
140	0.0017	0.0483
141	0.0017	0.0480
142	0.0017	0.0477
143	0.0017	0.0469
144	0.0017	0.0462
145	0.0016	0.0451
146	0.0016	0.0448
147	0.0016	0.0443
148	0.0015	0.0443
149	0.0015	0.0443
150	0.0015	0.0429
151	0.0015	0.0423
152	0.0013	0.0411
153	0.0013	0.0405
154	0.0012	0.0405
155	0.0009	0.0405
156	0.0004	0.0324
157	0.0003	0.0317
158	0.0002	0.0313

Duration Flows

Flow(cfs)	Predev	Mit	Percentage	Pass/Fail
0.0020	54265	409799	755	Fail
0.0021	50187	402430	801	Fail
0.0022	46586	395117	848	Fail
0.0022	43312	388026	895	Fail
0.0023	40287	381378	946	Fail
0.0024	37462	374785	1000	Fail
0.0025	34919	368525	1055	Fail
0.0025	32553	362542	1113	Fail
0.0026	30337	356669	1175	Fail
0.0027	28265	350908	1241	Fail
0.0027	26432	345312	1306	Fail
0.0028	24781	339883	1371	Fail
0.0029	23296	334786	1437	Fail
0.0030	21928	329689	1503	Fail
0.0030	20631	324814	1574	Fail
0.0031	19429	319994	1646	Fail
0.0032	18288	315119	1723	Fail
0.0033	17219	310465	1803	Fail
0.0033	16149	305922	1894	Fail
0.0034	15147	301601	1991	Fail
0.0035	14271	297280	2083	Fail
0.0036	13446	293236	2180	Fail
0.0036	12654	289247	2285	Fail
0.0037	11939	285202	2388	Fail
0.0038	11235	281324	2503	Fail
0.0039	10559	277502	2628	Fail
0.0039	9972	273790	2745	Fail
0.0040	9374	270078	2881	Fail
0.0041	8842	266477	3013	Fail
0.0042	8332	262931	3155	Fail
0.0042	7861	259497	3301	Fail
0.0043	7462	256228	3433	Fail
0.0044	7025	252904	3600	Fail
0.0045	6609	249580	3776	Fail
0.0045	6271	246422	3929	Fail
0.0046	5978	243209	4068	Fail
0.0047	5701	240162	4212	Fail
0.0048	5437	237170	4362	Fail
0.0048	5197	234068	4503	Fail
0.0049	4941	231131	4677	Fail
0.0050	4702	228195	4853	Fail
0.0051	4513	225370	4993	Fail
0.0051	4334	222489	5133	Fail
0.0052	4153	219774	5291	Fail
0.0053	3956	217060	5486	Fail
0.0054	3764	214400	5696	Fail
0.0054	3577	211797	5921	Fail
0.0055	3411	209193	6132	Fail
0.0056	3263	206700	6334	Fail
0.0057	3134	204151	6514	Fail
0.0057	3026	201714	6666	Fail
0.0058	2924	199387	6818	Fail
0.0059	2814	196949	6998	Fail
0.0060	2682	194678	7258	Fail

0.0060	2555	192185	7521	Fail
0.0061	2451	189913	7748	Fail
0.0062	2359	187697	7956	Fail
0.0063	2256	185481	8221	Fail
0.0063	2139	183265	8567	Fail
0.0064	2038	181160	8889	Fail
0.0065	1952	179055	9172	Fail
0.0066	1859	176894	9515	Fail
0.0066	1777	174789	9836	Fail
0.0067	1689	172739	10227	Fail
0.0068	1619	170745	10546	Fail
0.0069	1561	168806	10813	Fail
0.0069	1482	166756	11252	Fail
0.0070	1407	164817	11714	Fail
0.0071	1338	162989	12181	Fail
0.0072	1270	161050	12681	Fail
0.0072	1217	159221	13083	Fail
0.0073	1163	157338	13528	Fail
0.0074	1103	155565	14103	Fail
0.0075	1055	153792	14577	Fail
0.0075	1006	152019	15111	Fail
0.0076	963	150247	15601	Fail
0.0077	919	148474	16156	Fail
0.0078	872	146812	16836	Fail
0.0078	814	145150	17831	Fail
0.0079	772	143432	18579	Fail
0.0080	737	141770	19236	Fail
0.0081	694	140164	20196	Fail
0.0081	636	138502	21777	Fail
0.0082	601	136950	22787	Fail
0.0083	553	135344	24474	Fail
0.0084	517	133848	25889	Fail
0.0084	477	132297	27735	Fail
0.0085	433	130746	30195	Fail
0.0086	394	129305	32818	Fail
0.0087	363	127809	35209	Fail
0.0087	339	126369	37276	Fail
0.0088	310	124928	40299	Fail
0.0089	295	123488	41860	Fail
0.0090	273	121992	44685	Fail
0.0090	252	120607	47859	Fail
0.0091	237	119222	50304	Fail
0.0092	223	117893	52866	Fail
0.0093	206	116508	56557	Fail
0.0093	194	115178	59370	Fail
0.0094	179	113904	63633	Fail

The development has an increase in flow durations from 1/2 Predeveloped 2 year flow to the 2 year flow or more than a 10% increase from the 2 year to the 50 year flow.

The development has an increase in flow durations for more than 50% of the flows for the range of the duration analysis.

Water Quality

Water Quality BMP Flow and Volume for POC #1

On-line facility volume: 0.0204 acre-feet

On-line facility target flow: 0.0281 cfs.

Adjusted for 15 min: 0.0281 cfs.

Off-line facility target flow: 0.0162 cfs.

Adjusted for 15 min: 0.0162 cfs.

Cara Visintainer

From: Jordan Drugge <Jordan.Drugge@ContechES.com>
Sent: Thursday, May 16, 2024 3:18 PM
To: Logan Palmer
Cc: Jelena Vandenhaak; Cara Visintainer
Subject: RE: [EXTERNAL] 16718 West Bradley Park WQ
Attachments: SFMH48-DTL.pdf

Follow Up Flag: Follow up
Flag Status: Completed

Logan,

Please see the below size and cost estimate:

StormFilter Estimate:

Basic Treatment

WQ flowrate = 0.0162 cfs

Peak (100yr) flow = <1.8 cfs

(1) 18" Tall ZPG cartridge in a 48" SFMH

- Recommended min. drop of 2.3' from inlet to outlet invert

Rim to outlet invert depth = 6.51' (per plans)

Drop from inlet to outlet invert = 2.3' (per plans)

Two inlet pipes

- Approx. \$14K

Please note that the unit was changed from a SFCB to a SFMH as the max. rim to outlet invert depth for a steel SFCB is 4.5' and that for a concrete SFCB is 6.05'.

Standard detail is attached above for reference.

Let me know if you have any questions,
Thanks!

From: Logan Palmer <lpalmer@Barghausen.com>
Sent: Wednesday, May 15, 2024 3:42 PM
To: Jordan Drugge <Jordan.Drugge@ContechES.com>
Cc: Jelena Vandenhaak <Jelena.Vandenhaak@ContechES.com>; Cara Visintainer <cvisintainer@barghausen.com>
Subject: [EXTERNAL] 16718 West Bradley Park WQ

CAUTION: This email originated from outside of the organization. Exercise caution when opening attachments or clicking links, especially from *UNKNOWN* senders.

Hey Jordan, we need a water quality structure to treat a small area on this project, would be great if you could get us a detail along with a cost estimate.

Project is located at 707 39TH AVE. S.E. PUYALLUP, WA 98374. Basic treatment is required.

I am showing a single cartridge SFCB currently on the plans, attached for reference.

WQ flows:

Water Quality

Water Quality BMP Flow and Volume for POC #1

On-line facility volume: 0.0204 acre-feet

On-line facility target flow: 0.0281 cfs.

Adjusted for 15 min: 0.0281 cfs.

Off-line facility target flow: 0.0162 cfs.

Adjusted for 15 min: 0.0162 cfs.

Please let us know if you need any additional information.

Logan Palmer P.E. | Project Engineer

Office: 425-251-6222 | Ext: 7353

Barghausen Consulting Engineers, Inc.

18215 72nd Avenue South, Kent, WA 98032

<http://secure->

[web.cisco.com/19ymne_Q7y0Xfz7nYSEZ92GXIUeEEuVKFAXHe58qzsXLCUQK9hty_rH8RdEDT1dDfXfnRFqo_jzsk](http://secure-web.cisco.com/19ymne_Q7y0Xfz7nYSEZ92GXIUeEEuVKFAXHe58qzsXLCUQK9hty_rH8RdEDT1dDfXfnRFqo_jzskcoy95BAX-)

[ddHbLK4PYquNrMCwRaYSmhTJJvSfbZp4ksoDzmevzsG27b0HuvC9t2r3zIPsq3EfFc1JGjVmFxVTDkMYYmiXz2oZ5](http://secure-web.cisco.com/19ymne_Q7y0Xfz7nYSEZ92GXIUeEEuVKFAXHe58qzsXLCUQK9hty_rH8RdEDT1dDfXfnRFqo_jzskcoy95BAX-ddHbLK4PYquNrMCwRaYSmhTJJvSfbZp4ksoDzmevzsG27b0HuvC9t2r3zIPsq3EfFc1JGjVmFxVTDkMYYmiXz2oZ5)

[amJuUjhh-B3g5Kgw_5Z4sBG-](http://secure-web.cisco.com/19ymne_Q7y0Xfz7nYSEZ92GXIUeEEuVKFAXHe58qzsXLCUQK9hty_rH8RdEDT1dDfXfnRFqo_jzskcoy95BAX-amJuUjhh-B3g5Kgw_5Z4sBG-)

[8s8P8D70J9li813QJInIEdyDqJQ55x1aWrODb4GjIWgtkDtNqtCj_7epBVeyGWPMjPrmkIxuUm640U1wMXAxZ3Dvv0P2jUrHzm651jKLD4dg5_UYN9D1FTbkWI9syVGgbEjjZmKCJlauLc7Fm5XQ8ywor3d1N7VU7UsCeudcZxTHX8T](http://secure-web.cisco.com/19ymne_Q7y0Xfz7nYSEZ92GXIUeEEuVKFAXHe58qzsXLCUQK9hty_rH8RdEDT1dDfXfnRFqo_jzskcoy95BAX-8s8P8D70J9li813QJInIEdyDqJQ55x1aWrODb4GjIWgtkDtNqtCj_7epBVeyGWPMjPrmkIxuUm640U1wMXAxZ3Dvv0P2jUrHzm651jKLD4dg5_UYN9D1FTbkWI9syVGgbEjjZmKCJlauLc7Fm5XQ8ywor3d1N7VU7UsCeudcZxTHX8TWJfP4c3blcVoi_NBlhLkWM9P45Vp-rIw/http%3A%2F%2Fwww.barghausen.com)

[WJfP4c3blcVoi_NBlhLkWM9P45Vp-rIw/http%3A%2F%2Fwww.barghausen.com](http://secure-web.cisco.com/19ymne_Q7y0Xfz7nYSEZ92GXIUeEEuVKFAXHe58qzsXLCUQK9hty_rH8RdEDT1dDfXfnRFqo_jzskcoy95BAX-8s8P8D70J9li813QJInIEdyDqJQ55x1aWrODb4GjIWgtkDtNqtCj_7epBVeyGWPMjPrmkIxuUm640U1wMXAxZ3Dvv0P2jUrHzm651jKLD4dg5_UYN9D1FTbkWI9syVGgbEjjZmKCJlauLc7Fm5XQ8ywor3d1N7VU7UsCeudcZxTHX8TWJfP4c3blcVoi_NBlhLkWM9P45Vp-rIw/http%3A%2F%2Fwww.barghausen.com)

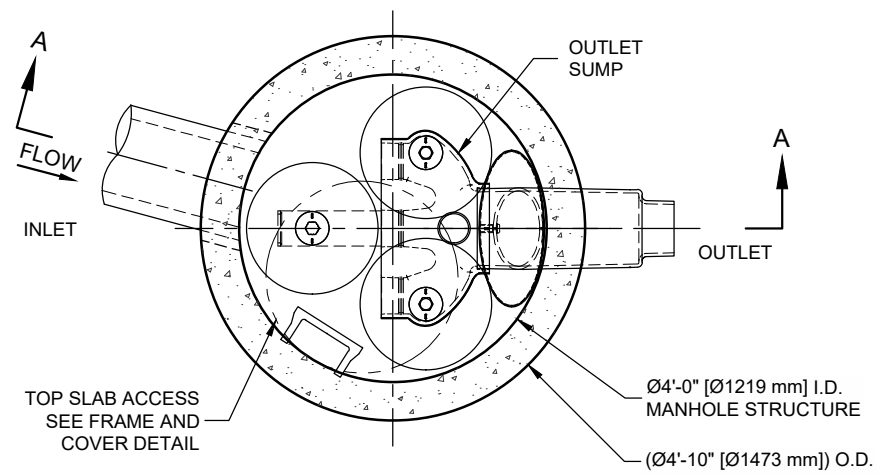

PLAN VIEW
STANDARD OUTLET RISER
FLOWKIT: 40A

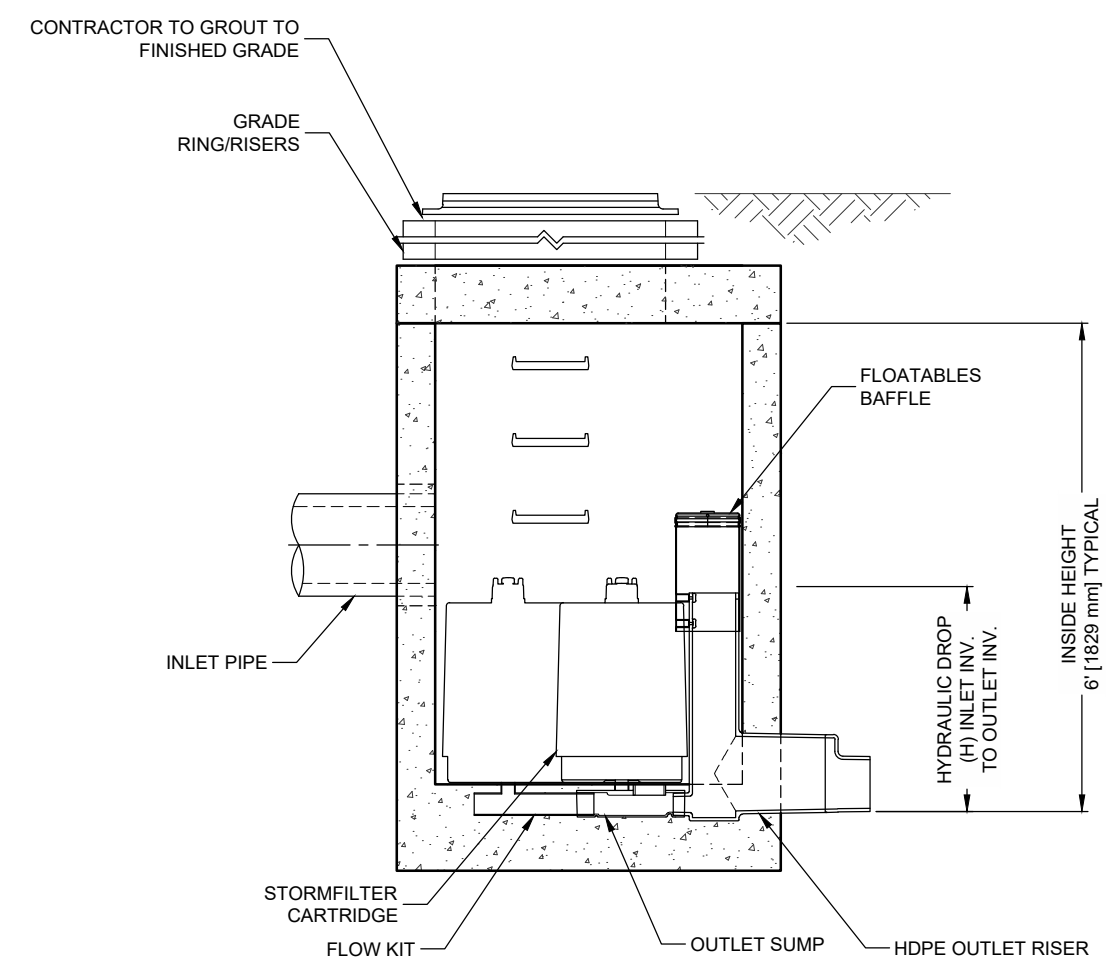

SECTION A-A

STORMFILTER DESIGN NOTES

STORMFILTER TREATMENT CAPACITY IS A FUNCTION OF THE CARTRIDGE SELECTION AND THE NUMBER OF CARTRIDGES. THE STANDARD MANHOLE STYLE IS SHOWN WITH THE MAXIMUM NUMBER OF CARTRIDGES (3). VOLUME SYSTEM IS ALSO AVAILABLE WITH MAXIMUM 3 CARTRIDGES. Ø4 [1219 mm] MANHOLE STORMFILTER PEAK HYDRAULIC CAPACITY IS 1.0 CFS [28.3 L/s] . IF THE SITE CONDITIONS EXCEED 1.0 CFS [28.3 L/s] AN UPSTREAM BYPASS STRUCTURE IS REQUIRED.

CARTRIDGE SELECTION

CARTRIDGE HEIGHT	27" [686 mm]			18" [458 mm]			LOW DROP		
RECOMMENDED HYDRAULIC DROP (H)	3.05' [930 mm]			2.3' [700 mm]			1.8' [550 mm]		
SPECIFIC FLOW RATE (gpm/sf) [L/s/m ²]	2 [1.30]	1.67* [1.08]	1 [0.65]	2 [1.30]	1.67* [1.08]	1 [0.65]	2 [1.30]	1.67* [1.08]	1 [0.65]
CARTRIDGE FLOW RATE (gpm) [L/s]	22.5 [1.42]	18.79 [1.19]	11.25 [0.71]	15 [0.95]	12.53 [0.79]	7.5 [0.44]	10 [0.63]	8.35 [0.54]	5 [0.32]

* 1.67 gpm/sf [1.08 L/s/m²] SPECIFIC FLOW RATE IS APPROVED WITH PHOSPHOSORB® (PSORB) MEDIA ONLY

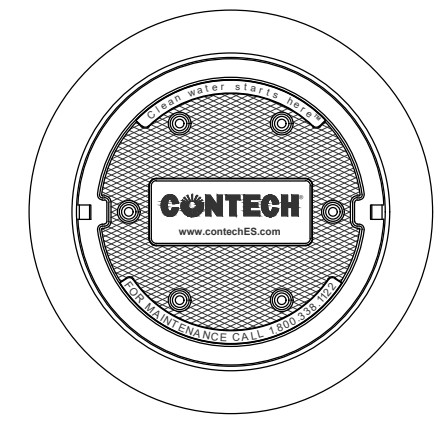

FRAME AND COVER
(DIAMETER VARIES)
N.T.S.

SITE SPECIFIC DATA REQUIREMENTS	
STRUCTURE ID	*
WATER QUALITY FLOW RATE (cfs) [L/s]	*
PEAK FLOW RATE (cfs) [L/s]	*
RETURN PERIOD OF PEAK FLOW (yrs)	*
CARTRIDGE HEIGHT (SEE TABLE ABOVE)	*
NUMBER OF CARTRIDGES REQUIRED	*
CARTRIDGE FLOW RATE	*
MEDIA TYPE (PERLITE, ZPG, PSORB)	*
PIPE DATA:	
	I.E. MATERIAL DIAMETER
INLET PIPE #1	* * *
INLET PIPE #2	* * *
OUTLET PIPE	* * *
RIM ELEVATION	
*	
ANTI-FLOTATION BALLAST	WIDTH HEIGHT
	* *
NOTES/SPECIAL REQUIREMENTS:	
* PER ENGINEER OF RECORD	

GENERAL NOTES

- CONTECH TO PROVIDE ALL MATERIALS UNLESS NOTED OTHERWISE.
- DIMENSIONS MARKED WITH () ARE REFERENCE DIMENSIONS. ACTUAL DIMENSIONS MAY VARY.
- FOR SITE SPECIFIC DRAWINGS WITH DETAILED VAULT DIMENSIONS AND WEIGHTS, PLEASE CONTACT YOUR CONTECH ENGINEERED SOLUTIONS LLC REPRESENTATIVE. www.contechES.com
- STORMFILTER WATER QUALITY STRUCTURE SHALL BE IN ACCORDANCE WITH ALL DESIGN DATA AND INFORMATION CONTAINED IN THIS DRAWING.
- STRUCTURE SHALL MEET AASHTO HS-20 LOAD RATING, ASSUMING EARTH COVER OF 0' - 5' [1524 mm] AND GROUNDWATER ELEVATION AT, OR BELOW, THE OUTLET PIPE INVERT ELEVATION. ENGINEER OF RECORD TO CONFIRM ACTUAL GROUNDWATER ELEVATION. CASTINGS SHALL MEET AASHTO M306 AND BE CAST WITH THE CONTECH LOGO.
- FILTER CARTRIDGES SHALL BE MEDIA-FILLED, PASSIVE, SIPHON ACTUATED, RADIAL FLOW, AND SELF CLEANING. RADIAL MEDIA DEPTH SHALL BE 7-INCHES [178 mm]. FILTER MEDIA CONTACT TIME SHALL BE AT LEAST 38 SECONDS.
- SPECIFIC FLOW RATE IS EQUAL TO THE FILTER TREATMENT CAPACITY (gpm) [L/s] DIVIDED BY THE FILTER CONTACT SURFACE AREA (sq ft)[m²].
- STORMFILTER STRUCTURE SHALL BE PRECAST CONCRETE CONFORMING TO ASTM C-478 AND AASHTO LOAD FACTOR DESIGN METHOD.

INSTALLATION NOTES

- ANY SUB-BASE, BACKFILL DEPTH, AND/OR ANTI-FLOTATION PROVISIONS ARE SITE-SPECIFIC DESIGN CONSIDERATIONS AND SHALL BE SPECIFIED BY ENGINEER OF RECORD.
- CONTRACTOR TO PROVIDE EQUIPMENT WITH SUFFICIENT LIFTING AND REACH CAPACITY TO LIFT AND SET THE STORMFILTER STRUCTURE.
- CONTRACTOR TO INSTALL JOINT SEALANT BETWEEN ALL STRUCTURE SECTIONS AND ASSEMBLE STRUCTURE.
- CONTRACTOR TO PROVIDE, INSTALL, AND GROUT INLET PIPE(S).
- CONTRACTOR TO PROVIDE AND INSTALL CONNECTOR TO THE OUTLET RISER STUB. STORMFILTER EQUIPPED WITH A DUAL DIAMETER HDPE OUTLET STUB AND SAND COLLAR. IF OUTLET PIPE IS LARGER THAN 8 INCHES [200 mm], CONTRACTOR TO REMOVE THE 8 INCH [200 mm] OUTLET STUB AT MOLDED-IN CUT LINE. COUPLING BY FERNCO OR EQUAL AND PROVIDED BY CONTRACTOR.
- CONTRACTOR TO TAKE APPROPRIATE MEASURES TO PROTECT CARTRIDGES FROM CONSTRUCTION-RELATED EROSION RUNOFF.

I:\STORMWATER\COMPS\10 STORMFILTER\40 STANDARD DRAWINGS\MANHOLE\SFMH48-DTL.DWG 4/5/2019 10:54 AM



THIS PRODUCT MAY BE PROTECTED BY ONE OR MORE OF THE FOLLOWING U.S. PATENTS: 5,322,629; 5,524,576; 5,707,527; 5,985,157; 6,027,639; 6,649,048; RELATED FOREIGN PATENTS, OR OTHER PATENTS PENDING.



www.contechES.com
9025 Centre Pointe Dr., Suite 400, West Chester, OH 45069
800-338-1122 513-645-7000 513-645-7993 FAX

SFMH48
STORMFILTER
STANDARD DETAIL

CONVEYANCE CALCULATIONS

PHASE 2 - CONVEYANCE MAP
FOR
PHASE 2 - WESLEY BRADLEY PARK

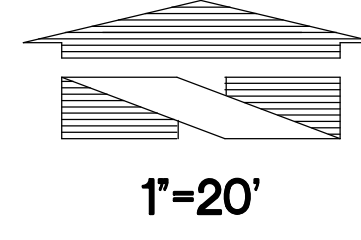

1"=20'

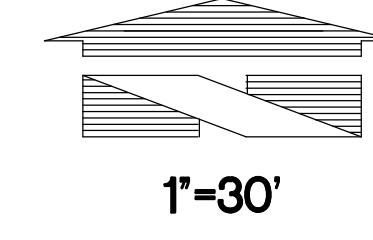
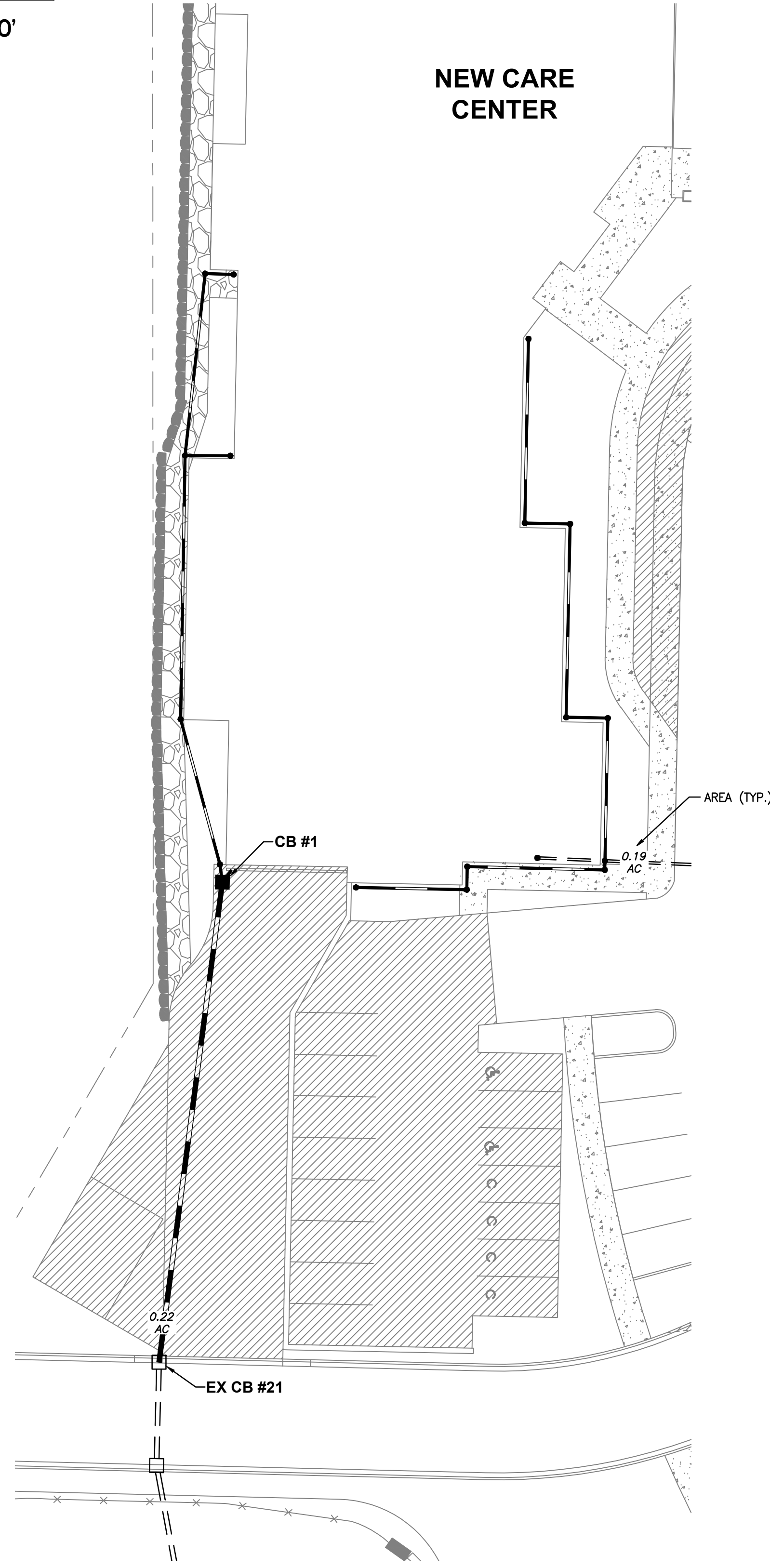

1"=30'

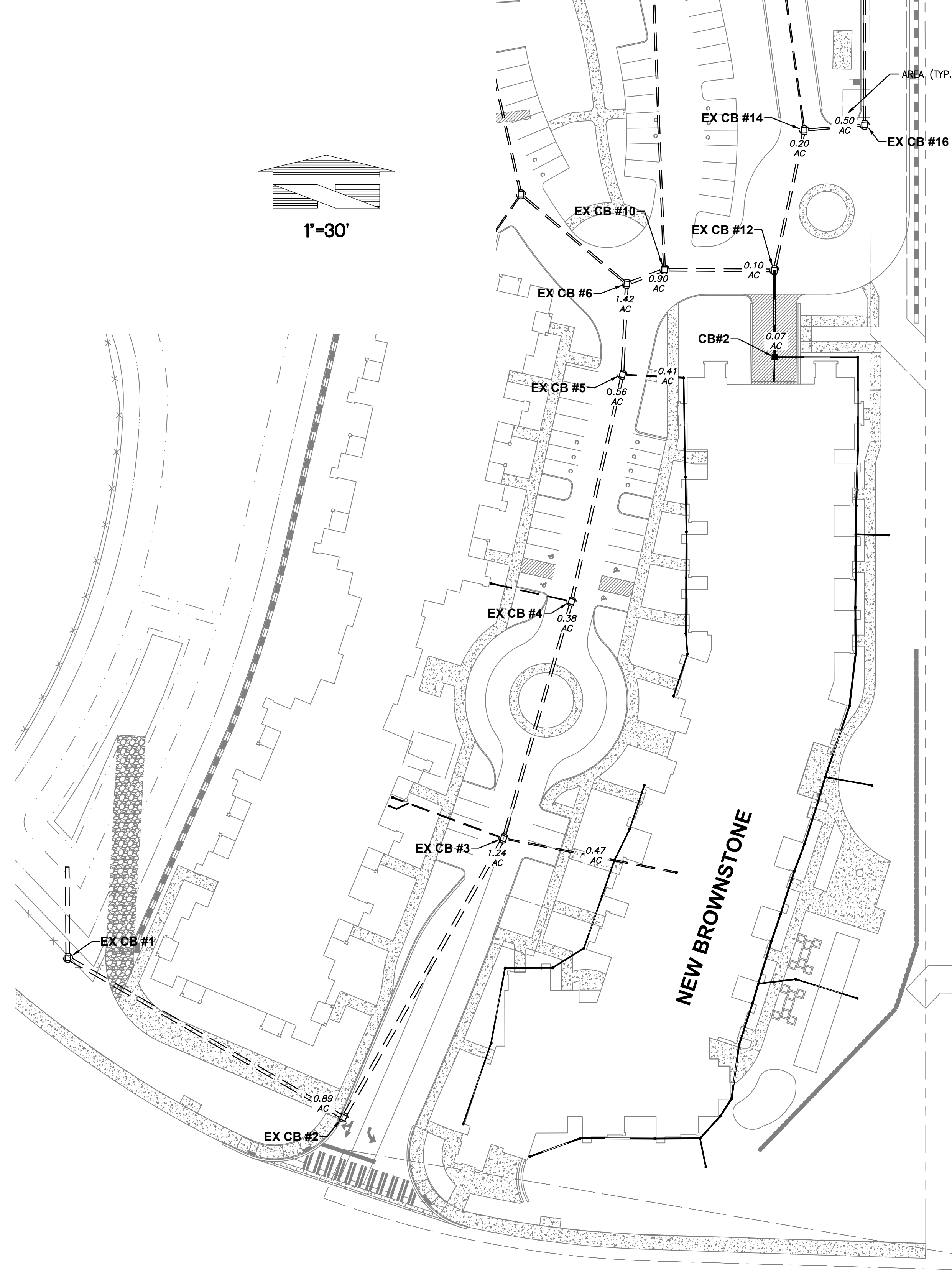

No.	Date	By	Chk.	Appr.	Revision

Title:

PHASE 2 - CONVEYANCE MAP
FOR
CIVIL PLANS
PHASE 2 - WESLEY BRADLEY PARK

For:
WESLEY HOMES
815 SOUTH 216TH STREET
DES MOINES, WA 98190
(206) 870-1209

Designed	CK	Scale:
Drawn	BBK	Horizontal
Checked	CMV	Vertical
Approved	DKB	
Date	7/6/23	

Barghausen Consulting Engineers, Inc.
18215 72nd Avenue South
Kent, WA 98032
425.251.6222 barghausen.com

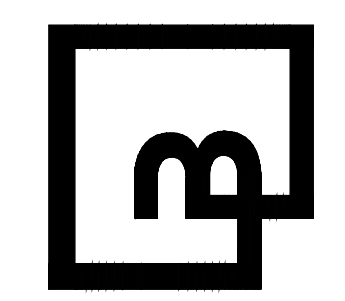

Job Number
16718

Sheet
1 of **1**

P:\16000a\16718\exhibit\Phase 2\16718-m30.dwg 7/5/2023 8:00 PM BKUNZ

BARGHAUSEN CONSULTING ENGINEERS - PIPE FLOW CALCULATOR
 using the Rational Method & Manning Formula
 KING COUNTY DESIGN FOR **25 YEAR STORM**

JOB NAME: PH2 - Wesley Bradley Park
 JOB#: 16718
 FILE NO.:

NOTE: ENTER DEFAULTS AND STORM DATA BEFORE BEGINNING			
DEFAULTS	C=	0.7	n= 0.012
	d=	12	Tc= 5

A= Contributing Area (Ac)
 C= Runoff Coefficient
 Tc= Time of Concentration (min)
 I= Intensity at Tc (in/hr)
 d= Diameter of Pipe (in)
 L= Length of Pipe (ft)
 D= Water Depth at Qd (in)

Qd= Design Flow (cfs)
 Qf= Full Capacity Flow (cfs)
 Vd= Velocity at Design Flow (fps)
 Vf= Velocity at Full Flow (fps)
 s= Slope of pipe (%)
 n= Manning Roughness Coefficient
 Tt= Travel Time at Vd (min)

COEFFICIENTS FOR THE RATIONAL METHOD "I_r"-EQUATION

STORM	Ar	Br	
2YR	1.58	0.58	
10YR	2.44	0.64	PRECIP= 3.5
25YR	2.66	0.65	Ar= 2.66
50YR	2.75	0.65	Br= 0.65
100YR	2.61	0.63	

FROM	TO	A	s	L	d	Tc	n	C	SUM A	A*C	SUM A*C	I	Qd	Qf	Qd/Qf	D/d	D	Vf	Vd	Tt
20	19	0.26	0.50	114	12	5.0	0.012	0.7	0.26	0.18	0.18	3.27	0.60	2.73	0.218	0.315	3.77	3.48	2.77	0.69
19	18	0.32	0.60	242	12	5.7	0.012	0.7	0.58	0.22	0.41	3.01	1.22	2.99	0.409	0.446	5.35	3.81	3.63	1.11
18	17	0.34	0.60	200	12	6.8	0.012	0.7	0.92	0.24	0.64	2.68	1.72	2.99	0.577	0.544	6.53	3.81	3.93	0.85
17	16	0.44	1.00	100	12	7.6	0.012	0.7	1.36	0.31	0.95	2.48	2.36	3.86	0.612	0.570	6.84	4.92	5.17	0.32
16	14	0.50	1.00	34	12	8.0	0.012	0.7	1.86	0.35	1.30	2.42	3.15	3.86	0.815	0.686	8.23	4.92	5.47	0.10
14	12	0.20	0.50	78	15	8.1	0.012	0.7	2.06	0.14	1.44	2.40	3.45	4.95	0.698	0.616	9.23	4.03	4.36	0.30
12	10	0.17	0.50	60	18	8.4	0.012	0.7	2.23	0.12	1.56	2.34	3.65	8.04	0.454	0.474	8.53	4.56	4.48	0.22
10	6	0.90	0.50	22	18	8.6	0.012	0.7	3.13	0.63	2.19	2.30	5.04	8.04	0.627	0.582	10.48	4.56	4.83	0.08
6	5	1.42	0.50	49	18	8.7	0.012	0.7	4.55	0.99	3.19	2.29	7.28	8.04	0.906	0.740	13.33	4.56	5.15	0.16
5	4	0.56	0.50	126	18	8.8	0.012	0.7	5.11	0.39	3.58	2.26	8.09	8.04	1.005	0.820	14.76	4.56	5.15	0.41
4	3	0.38	0.50	134	18	9.2	0.012	0.7	5.49	0.27	3.84	2.19	8.44	8.04	1.049	0.874	15.73	4.56	5.15	0.43
3	2	1.24	0.50	175	21	9.7	0.012	0.7	6.73	0.87	4.71	2.13	10.04	12.13	0.827	0.693	14.55	5.05	5.64	0.52
2	1	0.89	0.50	173	24	10.2	0.012	0.7	7.62	0.62	5.33	2.06	10.99	17.32	0.634	0.585	14.04	5.52	5.86	0.49
1	POND	0.00	0.63	54	24	10.7	0.012	0.7	7.62	0.00	5.33	2.00	10.65	19.45	0.548	0.527	12.66	6.19	6.32	0.14

SOILS REPORT

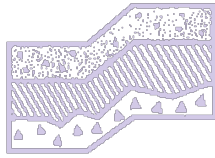

TERRA ASSOCIATES, Inc.

Consultants in Geotechnical Engineering, Geology
and
Environmental Earth Sciences

December 29, 2022
Project No. T-5915-3

Mr. Stephen Nornes
Presbyterian Homes & Services and Senior Housing Partners
2823 Hamline Avenue N
Roseville, Minnesota 55113

Subject: Geotechnical Report Addendum
Wesley Homes Expansion
Puyallup, Washington

Reference: Geotechnical Report, Wesley Homes Puyallup, 39th Avenue SE, Puyallup, Washington, Project No. T-5915-3, prepared by Terra Associates, Inc., revised date November 14, 2016

Dear Mr. Nornes:

This geotechnical report addendum has been prepared in response to comments from the City of Puyallup Planning Division. The comments were outlined in a Development Review Team (DRT) letter dated November 23, 2022. Specifically, the city has requested our current referenced report be updated to address geologically hazardous areas focusing on the steep sloped area west of the planned 36 bed care center building and infiltration feasibility for hardscape permeable pavements.

Project Description

The project consists of completing the development by constructing two previously planned buildings that were not constructed when the first phase was constructed. One building (Brownstone) is located in the southeast corner of the site with the second building (Care Center) located west and adjacent the existing Lodge building. Based on review of preliminary grading plans prepared by Barghausen Consulting Engineers, stamp dated June 21, 2022, the Care Center building will have its main floor level constructed at elevation 458 feet with the southeast Brownstone building floor constructed at elevation 475 feet. Review of Architectural drawings prepared by In Site Architects, indicates the Care Center will have a lower level constructed at floor elevations of 454 feet in the northern half of the building rising up to elevation 457 feet in the southern half of the building. The northern lower floor portion of the building will feature a fitness area that will include an indoor pool. The southern portion of the building will serve as below grade parking matching the parking grade of the adjacent Lodge building.

Geologically Hazardous Areas

Erosion Hazard

Title 21.06.1210 of the Puyallup Municipal Code (PMC) defines erosion hazardous areas as follows:

- Erosion hazard area are those areas identified by the U.S. Department of Agriculture’s Natural Resources Conservation Service (NRCS) or identified by a special study as having a “moderate to severe,” “severe,” or “very severe” erosion potential.

The NRCS maps the soils on the site as Neilton gravelly loamy sand, 8 to 25 percent slopes. This soil category has a severe erosion potential ranking. Therefore, the site is an erosion hazard area as defined by the PMC. In our opinion, the erosion hazard can be adequately mitigated by implementing appropriate erosion control best management practices (BMP’s) during and following construction. These practices would include temporary and permanent drainage control elements and cover measures that would prevent erosion from occurring.

Landslide Hazard

The PMC defines landslide hazard areas as follows:

- a. Landslide hazard areas include areas subject to landslides based on a combination of geologic, topographic, and hydrologic factors. They include any areas susceptible to landslide because of any combination of bedrock, soil, slope (gradient), slope aspect, structure, hydrology, or other factors, and include, at a minimum, the following:
 - i. Areas of historic failures, such as:
 1. Those areas delineated by the United States Department of Agriculture Natural Resources Conservation Service as having a significant limitation for building site development;
 2. Those coastal areas mapped as class u (unstable), uos (unstable old slides), and urs (unstable recent slides) in the Department of Ecology Washington coastal atlas; or
 3. Areas designated as quaternary slumps, earthflows, mudflows, lahars, or landslides on maps published by the United States Geological Survey or Washington Department of Natural Resources.
 - ii. Areas with all three of the following characteristics.
 1. Slopes steeper than 15 percent;
 2. Hillsides intersecting geologic contacts with a relatively permeable sediment overlying a relatively impermeable sediment or bedrock; and
 3. Springs or groundwater seepage.

- iii. Areas that have shown movement during the holocene epoch (from 10,000 years ago to the present) or which are underlain or covered by mass wastage debris of this epoch;
- iv. Slopes that are parallel or subparallel to planes of weakness (such as bedding planes, joint systems, and fault planes) in subsurface materials;
- v. Slopes having gradients steeper than eighty percent subject to rockfall during seismic shaking;
- vi. Areas potentially unstable as a result of rapid stream incision, stream bank erosion, and undercutting by wave action, including stream channel migration zones;
- vii. Areas that show evidence of, or are at risk from snow avalanches;
- viii. Areas located in a canyon or on an active alluvial fan, presently or potentially subject to inundation by debris flows or catastrophic flooding; and
- ix. Any area with a slope of 40 percent or steeper and with a vertical relief of 10 or more feet except areas composed of bedrock. A slope is delineated by establishing its toe and top and measured by averaging the inclination over at least 10 feet of vertical relief.

The east flank of the drainage swale immediately west and adjacent to the Care Center building is a 50 percent slope with vertical relief in excess of 20 feet. Therefore, it is a landslide hazard area as defined by the PMC. This is a manmade drainage constructed to convey runoff flows from a wetland complex south of 37th Avenue SE along the east side of the Lowes retail development north to Bradley Lake.

Recent reconnaissance of the slope area found no evidence of slope instability or erosion. The slope is well vegetated with a thick grass cover along with scattered young deciduous and coniferous trees and some brush. Tree growth is generally straight with no significant signs of leaning or pistol butted trunks.

The west side of the Care Center building is located on the slope. The proposed lower floor grade of the building will require placement of four to five feet of fill material to establish the floor subgrade along the western building margin with excavations of five to ten feet required in the central and eastern portions of the building. Provided site grading and building support is completed in accordance with recommendations outlined in the referenced geotechnical report, construction of the Care Center building at the planned location would have no adverse impact on the slope. These recommendations include excavation and removal of unsuitable fill material from below the central and northern portions of the building and replacing these soils with compacted structural fill. Alternatively supporting the building in this unsuitable fill area on foundation piles or on ground improved using rammed aggregate piers can also be considered.

Seismic Hazard

The PMC defines seismic hazard areas as follows:

- **Seismic Hazard Areas.** Seismic hazard areas are areas subject to severe risk of damage as a result of earthquake-induced ground shaking, slope failure, settlement or subsidence, soil liquefaction, or tsunamis.

Mr. Stephen Nornes
December 29, 2022

Settlement and soil liquefaction conditions occur in areas underlain by cohesionless, loose, or soft-saturated soils of low density, typically in association with a shallow ground water table.

Seismic considerations as discussed in the referenced report continue to remain valid for the project. The exception to this is the seismic design parameters. The parameters in the referenced report are based on the 2015 International Building Code (IBC). Per the current 2018 IBC, for site class C, the following parameters should be used in calculating seismic forces:

Seismic Design Parameters (IBC 2018)

Spectral response acceleration (Short Period), S_{Ms}	1.509
Spectral response acceleration (1 – Second Period), S_{M1}	0.651
Five percent damped .2 second period, S_{Ds}	1.006
Five percent damped 1.0 second period, S_{D1}	0.434

These values were determined using latitude/longitude coordinates 47.156423/-122.283429 and the Structural Engineers Association of California (SEAOC) ground motion parameter calculator accessed on December 27, 2022 at the web site <https://www.seismicmaps.org>.

Infiltration Feasibility

Our discussion regarding infiltration feasibility as outlined in the referenced report continues to remain valid for the project. Based on conditions observed during phase I construction, it is also our opinion that site conditions are not suitable for using permeable pavements. During phase I construction shallow seepage conditions developed along the east side of the Lodge building and west and adjacent the soldier pile wall construction on the east property line. Persistent shallow seepage affected the subgrade and resulted in seepage into the lower garage level of the Lodge building. Shallow subsurface drains had to be installed to mitigate the seepage impacts. Even if field testing were to indicate infiltration rates of .3 inches per hour or greater were present at the pavement subgrade elevations, because of likely restrictions to flow at shallow depths, which could possibly redirect infiltrated water towards the building or the west drainage slope, use of permeable pavements is not recommended.

We trust the information presented is sufficient for your current needs. If you have any questions or require additional information, please call.

Sincerely yours,
TERRA ASSOCIATES, INC.

Theodore J. Schepper 12-29-22

Theodore J. Schepper, P.E.
Senior Principal Engineer

Cc: Ms. Jill Krance, In Site Architects
Mr. Dan Balmelli, P.E., Barghausen Consulting Engineers

GEOTECHNICAL REPORT

**Wesley Homes Puyallup
39th Avenue SE
Puyallup, Washington**

Project No. T-5915-3

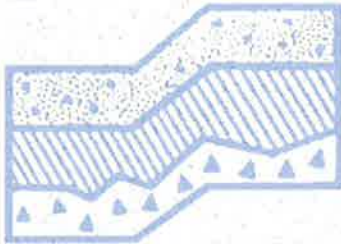

Terra Associates, Inc.

Prepared for:

**Wesley Homes
Des Moines, Washington**

**October 28, 2015
Revised November 14, 2016**



TERRA ASSOCIATES, Inc.

Consultants in Geotechnical Engineering, Geology
and
Environmental Earth Sciences

October 28, 2015
Revised November 14, 2016
Project No. T-5915-3

Mr. Kevin Anderson
Wesley Homes
815 South 216th Street
Des Moines, Washington 98198

Subject: Geotechnical Report
Wesley Homes Puyallup
39th Avenue SE
Puyallup, Washington

Dear Mr. Anderson:

As requested, we have conducted a geotechnical engineering study for the subject project. The attached report presents our findings and recommendations for the geotechnical aspects of project design and construction.

Our field exploration indicates the soil conditions generally consist of 2 to 18 inches of organic topsoil overlying glacial drift deposits composed of a varying mixture of silty sand, sand, gravel, and silt. In general, the soils were found in a medium dense to dense condition. The exception to this general condition was observed in Test Pit TP-103 where we observed approximately 13.5 feet of organic fill material overlying the native soils. Similar fill material was also observed in Test Pits TP-11 and TP-12 by GeoEngineers (2003) and Test Pit TP-8 by Terra Associates, Inc. (2006).

These fill soils observed are not suitable for building support and should be removed and replaced with new structural fill. Alternatively, the northern buildings may be supported on deep foundations such as pipe piles or on ground improved by installation of Geopiers.

In our opinion, the native soils on the site will be suitable for support of the proposed development provided the recommendations presented in this report are incorporated into project design and construction.

Mr. Kevin Anderson
October 28, 2015
Revised November 14, 2016

We trust the information presented in this report is sufficient for your current needs. If you have any questions or require additional information, please call.

Sincerely yours,
TERRA ASSOCIATES, INC.

Carolyn S. Decker, P.E.
Project Engineer

Theodore J. Schepper, P.E.
President

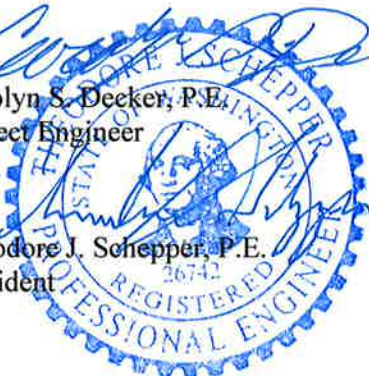

11-14-16

TABLE OF CONTENTS

	<u>Page No.</u>
1.0 Project Description.....	1
2.0 Scope of Work	1
3.0 Site Conditions.....	2
3.1 Surface	2
3.2 Soils	2
3.3 Groundwater	3
4.0 Geologic Hazards.....	3
4.1 Seismic Considerations	3
4.2 Erosion	4
4.3 Landslide Hazard	5
5.0 Discussion and Recommendations.....	5
5.1 General.....	5
5.2 Site Preparation and Grading	6
5.3 Excavations	7
5.4 Slopes and Embankments	8
5.5 Foundations.....	8
5.6 Slab-on-Grade Construction	10
5.7 Lateral Earth Pressure on Below-Grade Walls	10
5.8 Stormwater Detention Pond.....	11
5.9 Drainage.....	11
5.10 Utilities.....	12
5.11 Pavements	12
6.0 Additional Services.....	13
7.0 Limitations	13

Figures

Vicinity Map.....	Figure 1
Exploration Location Plan	Figure 2
Typical Slope Key and Bench Detail.....	Figure 3
Typical Wall Drainage Detail.....	Figure 4

Appendices

Field Exploration and Laboratory Testing.....	Appendix A
Previous Test Pit Logs.....	Appendix B

Geotechnical Report Wesley Homes Puyallup 39th Avenue SE Puyallup, Washington

1.0 PROJECT DESCRIPTION

The project consists of developing the approximately 14-acre site with a senior housing complex. The complex will include a multi-story building, two brownstone buildings, a stormwater detention pond, and associated access and utility improvements. Based on the grading and storm drainage plan prepared by Barghausen Consulting Engineers dated April 6, 2016, grading to achieve building lot and roadway grades will consist of cuts and fills from 1 to 13 feet. Vertical grade transitions will be supported by retaining walls.

Stormwater will be collected and routed to a detention pond located in the southwest portion of the site. The pond will be formed by a combination of excavation below current site grade, construction of a fill containment berm along the northwest perimeter, and construction of a retaining wall along the east perimeter. The excavation required to achieve the floor elevation of 447.0 will extend 11 to 15 feet below current site grades. The fill depth required to achieve the berm crest elevation of 459.0 will range from 6 to 9 feet.

We expect the multi-story building and brownstone buildings to be wood-framed with slab-on-grade floors producing moderate foundation loads with bearing wall and isolated column loads ranging from about 4 to 6 kips per foot and 200 to 400 kips.

The recommendations in the following sections of this report are based on our understanding of the preceding design features. We should review design drawings as they become available to verify that our recommendations have been properly interpreted and to supplement them, if required.

2.0 SCOPE OF WORK

Our work was completed in accordance with our proposal dated June 1, 2015. Accordingly, on October 13, 2015, we excavated 12 test pits to a maximum depth of 15 feet below existing surface grades. Using the information obtained from our recent subsurface exploration, previous subsurface exploration, and laboratory testing, we performed analyses to develop geotechnical recommendations for project design and construction. Specifically, this report addresses the following:

- Soil and groundwater conditions
- Seismic Criteria per 2015 International Building Code (IBC)
- Geologic Hazards per City of Puyallup Municipal Code
- Site preparation and grading
- Slopes and embankments
- Excavations

- Foundations
- Slab-on-grade floors
- Stormwater detention pond
- Low Impact Development (LID) Methods
- Lateral earth pressure parameters for wall design
- Drainage
- Utilities
- Pavements

It should be noted that recommendations outlined in this report regarding drainage are associated with soil strength, design earth pressures, erosion, and stability. Design and performance issues with respect to moisture as it relates to the structure environment are beyond Terra Associates' purview. A building envelope specialist or contractor should be consulted to address these issues, as needed.

3.0 SITE CONDITIONS

3.1 Surface

The project site is located on the north side of 37th Avenue SE Street approximately 80 feet west of the intersection with 10th Street SE in Puyallup, Washington. The approximate location of the site is shown on the Vicinity Map, Figure 1.

The site is irregular in plan dimension measuring approximately 370 by 1,270 feet. An electrical substation exists east of the property. The majority of the project site slopes gently down towards the west. Overall relief across the site is about 50 feet. The western site margin is bounded by a west-facing slope with approximately 20 feet of local relief with a gradient of about 14 to 30 percent. The site is covered with large to medium-sized Evergreen and deciduous trees and moderate growth of underbrush.

3.2 Soils

In general, the soil conditions observed in the recent test pits consisted of 2 to 18 inches of organic topsoil overlying glacial drift deposits composed of varying mixtures of silty sand, sand, gravel, and silt. In general, the soils were found in a medium dense to dense condition. The exception to this general condition was observed in Test Pit TP-103 where we observed approximately 13.5 feet of organic fill material overlying the native soils. Similar fill material was also observed in Test Pits TP-11 and TP-12 by GeoEngineers (2003) and Test Pit TP-8 by Terra Associates, Inc. (2006).

The *Geologic Map of the South Half of The Tacoma Quadrangle, Washington*, by Timothy J. Walsh, dated 1987 maps the soils as Vashon glacial drift (Vdv). The Vashon glacial drift is described as recessional and interglacial stratified outwash sands and gravels, locally containing silts and clays. Native soil conditions we observed in our test pits are consistent with this mapped geology.

The preceding discussion is intended as a general review of the soil conditions encountered. A more detailed description of the subsurface conditions encountered is presented on the Test Pit Logs in Appendix A. The approximate test pit locations are shown on Figure 2. Figure 2 also shows the location of previous test pits excavated by GeoEngineers and Terra Associates, Inc. Previous test pit logs prepared by GeoEngineers and Terra Associates, Inc. are included in Appendix B.

3.3 Groundwater

We observed groundwater seepage in Test Pits TP-107, TP-109, and TP-110 between 7 and 11 feet below current site grades which equates to approximately elevation 443 to 445 feet relative to site elevations. The groundwater was observed flowing from a recessional gravel outwash layer. Previous site exploration test pits excavated by GeoEngineers in March 2003 encountered similar groundwater flows from this gravel layer at depths of five to nine feet below site grades. Based on the location of the test pits and elevation of the groundwater, it appears that the groundwater observed represents a localized shallow groundwater table residing in the gravel outwash.

Although we did not observe groundwater in the other test pits we did observe mottled or iron staining of the upper few feet of many of the soil layers indicating perched shallow groundwater tables likely develop during the normally wet winter months.

4.0 GEOLOGIC HAZARDS

4.1 Seismic Considerations

Section 21.06.210 (113) of the City of Puyallup Municipal Code (PMC) defines Seismic hazard areas as “areas that are subject to severe risk of damage as a result of earthquake-induced ground shaking, slope failure, settlement, or soil liquefaction.”

Liquefaction is a phenomenon where there is a reduction or complete loss of soil strength due to an increase in water pressure induced by vibrations. Liquefaction mainly affects geologically recent deposits of fine-grained sand that are below the groundwater table. Soils of this nature derive their strength from intergranular friction. The generated water pressure or pore pressure essentially separates the soil grains and eliminates this intergranular friction; thus, eliminating the soil’s strength.

Based on the soil and groundwater conditions we observed, it is our opinion that there is minimal risk for liquefaction related impacts to occur at this site during an earthquake.

Based on soil conditions observed in the test borings and our knowledge of the area geology, per Chapter 16 of the 2015 International Building Code (IBC), site class “C” should be used in structural design. Based on this site class, in accordance with the 2015 IBC, the following parameters should be used in computing seismic forces:

Seismic Design Parameters (IBC 2015)

Spectral response acceleration (Short Period), S_{Ms}	1.244
Spectral response acceleration (1 – Second Period), S_{M1}	0.632
Five percent damped .2 second period, S_{Ds}	0.829
Five percent damped 1.0 second period, S_{D1}	0.421

These values were determined using the latitude/longitude coordinates 47.156499/-122.283487 and the United States Geological Survey (USGS) Ground Motion Parameter Calculator accessed on November 9, 2016 at the web site <http://earthquake.usgs.gov/designmaps/us/application.php>.

4.2 Erosion

Section 21.06.210 (40) of the PMC defines Erosion hazard areas as “lands or areas underlain by soils identified by the U.S. Department of Agriculture Natural Resource Conservation Service (NRCS) as having “severe” or “very severe” erosion hazards. These include, but are not limited to, the following group of soils when they occur on slopes of 15 percent or greater: Alderwood gravelly sandy loam, Indianola gravelly loam, Kapowsin gravelly loam, Kitsap silt loam (KpD), and Xerochrepts.”

The soils observed on-site are classified as Everett gravelly sand loam 0 to 6 percent slopes and Neilton gravelly loamy sand, 8 to 25 percent slopes by the United States Department of Agriculture Natural Resources Conservation Service (NRCS), formerly the Soil Conservation Service. With the existing slope gradients, these soils will have a slight to severe potential for erosion when exposed. Therefore, the site is an erosion hazard area as defined by the PMC.

Implementation of temporary and permanent Best Management Practices (BMPs) for preventing and controlling erosion will be required and will mitigate the erosion hazard. As a minimum, we recommend implementing the following erosion and sediment control BMPs prior to, during, and immediately following construction activities at the site.

Prevention

- Limit site clearing and grading activities to the relatively dry months (typically May through September).
- Limit disturbance to areas where construction is imminent.
- Locate temporary stockpiles of excavated soils no closer than ten feet from the crest of slopes.
- Provide temporary cover for cut slopes and soil stockpiles during periods of inactivity. Temporary cover may consist of durable plastic sheeting that is securely anchored to the ground surface or straw mulch.
- Establish permanent cover over exposed areas that will not be disturbed for a period of 30 days or more by seeding, in conjunction with a mulch cover or appropriate hydroseeding.

Containment

- Install a silt fence along site margins and downslope of areas that will be disturbed. The silt fence should be in place before clearing and grading is initiated.
- Intercept surface water flow and route the flow away from the slope to a stabilized discharge point. Surface water must not discharge at the top or onto the face of the steep slope.
- Provide on-site sediment retention for collected runoff.

The contractor should perform daily review and maintenance of all erosion and sedimentation control measures at the site.

4.3 Landslide Hazard

Section 21.06.210 (81) of the PMC defines Landslide Hazard areas as “areas that, due to a combination of site conditions like slope inclination and relative soil permeability are susceptible to landsliding.”

With the soil conditions and existing slope gradients observed at the site, in our opinion the site does not contain any landslide hazard areas as defined by the PMC.

5.0 DISCUSSION AND RECOMMENDATIONS

5.1 General

Based on our study, from a geotechnical engineering perspective, the site is suitable for the proposed development. The competent inorganic native soils would provide suitable support for conventional spread footing foundations. Alternatively, if required by desired final building elevations, structural fill placed and compacted above these native soils can be used to support the building foundations. Floor slabs and pavements can be similarly supported.

The existing fill soils observed to depths of 15 feet in the northern area of the site will not be suitable for building support. These existing fills will either need to be removed and replaced with new structural fill or the building foundations and floor supported on piles driven or drilled through the fill into the underlying competent native soils. The lateral extent of the undocumented fill will need to be determined in the field during grading.

Some of the native soils encountered at the site contain a significant amount of fines and will be difficult to compact as structural fill when too wet. The ability to use native silty soils from site excavations as structural fill will depend on its moisture content and the prevailing weather conditions at the time of construction. If grading activities will take place during the winter season, the owner should be prepared to import free-draining granular material for use as structural fill and backfill. The cleaner gravelly sand and sand layers would be suitable for use as structural fill under most weather conditions. The existing organic fill material would not be suitable for reuse as structural fill.

Detailed recommendations regarding the above issues and other geotechnical design considerations are provided in the following sections. These recommendations should be incorporated into the final design drawings and construction specifications.

5.2 Site Preparation and Grading

To prepare the site for construction, existing surface vegetation and other deleterious materials should be stripped and removed. Based on conditions observed at the test pits, we would estimate that surface stripping depths of 2 to 18 inches will be required to remove site vegetation and associated near-surface organic debris. Vegetation debris from clearing operations should be removed from the site. Organic topsoil will not be suitable for use as structural fill, but may be used for limited depths in nonstructural areas.

If the northern building in the vicinity of Terra Test Pits TP-103 and TP-8 and GeoEngineers Test Pits TP-11 and TP-12 are not supported on piles, the existing fill will need to be removed and replaced with structural fill for building support. Excavations to remove the existing fill will, based on the test pits, extend to depths of at least 15 feet below current site grades. The lateral extent of the undocumented fill material will need to be determined in the field during grading.

Once clearing and stripping operations are complete, cut and fill operations can be initiated to establish desired grades. Prior to placing fill, all exposed bearing surfaces should be observed by a representative of Terra Associates to verify soil conditions are as expected and suitable for support of new fill. Our representative may request a proofroll using heavy rubber-tired equipment to determine if any isolated soft and yielding areas are present. If excessively yielding areas are observed, and they cannot be stabilized in place by compaction, the affected soils should be excavated and removed to firm bearing and grade restored with new structural fill. Beneath embankment fills or roadway subgrade if the depth of excavation to remove unstable soils is excessive, the use of geotextile fabrics, such as Mirafi 500X, or an equivalent fabric, can be used in conjunction with clean granular structural fill. Our experience has shown that, in general, a minimum of 18 inches of a clean, granular structural fill placed and compacted over the geotextile fabric should establish a stable bearing surface.

Some of the native soils encountered at the site contain a significant amount of fines and will be difficult to compact as structural fill when too wet. The ability to use native silty soils from site excavations as structural fill will depend on its moisture content and the prevailing weather conditions at the time of construction. If grading activities will take place during the winter season, the owner should be prepared to import free-draining granular material for use as structural fill and backfill. The cleaner sand and gravel layers would be suitable for use as structural fill under most weather conditions.

If imported fill is needed for site grading or subgrade preparation, we recommend that the fill consist of inorganic granular soil meeting the following gradation:

U.S. Sieve Size	Percent Passing
3 inches	100
No. 4	75 maximum
No. 200	5 maximum*

*Based on the 3/4-inch fraction.

Prior to use, Terra Associates, Inc. should examine and test all materials imported to the site for use as structural fill.

Structural fill should be placed in uniform loose layers not exceeding 12 inches and compacted to a minimum of 95 percent of the soil's maximum dry density, as determined by American Society for Testing and Materials (ASTM) Test Designation D-698 (Standard Proctor). The moisture content of the soil at the time of compaction should be within two percent of its optimum, as determined by this ASTM standard. In nonstructural areas the degree of compaction can be reduced to 90 percent.

5.3 Excavations

All excavations at the site associated with confined spaces, such as utility trenches and lower building levels, must be completed in accordance with local, state, or federal requirements. Based on current Washington State Industrial Safety and Health Administration (WISHA) regulations, the upper loose uncontrolled fill and medium dense to dense native soils at the site would be classified as Type C soils. The deeper very dense native soils would be classified as Type A soils.

Accordingly, temporary excavations in Type C soils should have their slopes laid back at an inclination of 1.5:1 (Horizontal:Vertical) or flatter, from the toe to the crest of the slope. Side slopes in Type A soils can be laid back at a slope inclination of 0.75:1 or flatter. For temporary excavation slopes less than 8 feet in height in Type A soils, the lower 3.5 feet can be cut to a vertical condition, with a 0.75:1 slope graded above. For temporary excavation slopes greater than 8 feet in height up to a maximum height of 12 feet, the slope above the 3.5-foot vertical portion will need to be laid back at a minimum slope inclination of 1:1. No vertical cut with a backslope immediately above is allowed for excavation depths that exceed 12 feet. In this case, a four-foot vertical cut with an equivalent horizontal bench to the cut slope toe is required. All exposed temporary slope faces that will remain open for an extended period of time should be covered with a durable reinforced plastic membrane during construction to prevent slope raveling and rutting during periods of precipitation.

Site exploration indicates the presence of a localized shallow groundwater table contained in the gravel outwash layer at depths of 5 to 11 feet below current site grades. Also perched groundwater development can be expected at the site during the winter season. The contractor should be prepared to dewater site excavations as needed to maintain stability and relatively dry working conditions. Dewatering using conventional sump pumps along with collector trenches at the excavation base or perimeter cut off drains to capture and control seepage before it enters the excavation will need to be considered.

The above information is provided solely for the benefit of the owner and other design consultants, and should not be construed to imply that Terra Associates, Inc. assumes responsibility for job site safety. Job site safety is the sole responsibility of the project contractor.

5.4 Slopes and Embankments

All permanent cut and fill slopes should be graded with a finished inclination of no greater than 2:1 (Horizontal:Vertical). Upon completion of grading, the slope face should be appropriately vegetated or provided with other physical means to guard against erosion. Final grades at the top of the slope must promote surface drainage away from the slope crest. Water must not be allowed to flow uncontrolled over the slope face. If surface runoff must be directed towards the slope, the runoff should be controlled at the top of the slope, piped in a closed conduit installed on the slope face, and taken to an appropriate point of discharge beyond the toe.

All fill placed for embankment construction should meet the structural fill requirements in Section 5.2 of this report. In addition, if the new fills will be placed over existing slopes of 20 percent or greater, the structural fill should be keyed and benched into competent native slope soils. Figure 3 presents a typical slope key and bench configuration. At minimum, a toe drain should be installed in the key cut as shown on Figure 3. Depending on seepage conditions, drains may also be required along individual benches excavated on the slope face especially along the pond slopes. The need for drains along the upper benches will be best determined in the field at the time of construction.

5.5 Foundations

Spread Footings

The buildings may be supported on conventional, isolated, or continuous spread footing foundations bearing on the competent undisturbed native soils or structural fill placed on undisturbed competent native soils. Spread footing foundations bearing on undisturbed subgrade composed of the native soils and compacted structural fill can be designed for a net allowable bearing capacity 3,000 pounds per square foot (psf). For short-term loads, such as wind and seismic, a one-third increase in the allowable bearing capacity may be used. For the structural loading expected, we estimate total settlement of isolated spread footings will be one-inch or less, with differential settlement of one-half inch and less.

For designing foundations to resist lateral loads, a base friction coefficient of 0.35 can be used. Passive earth pressures acting on the side of the footing can also be considered. We recommend calculating this lateral resistance using an equivalent fluid weight of 350 pcf. We recommend not including the upper 12 inches of soil in this computation because they can be affected by weather or disturbed by future grading activity. This value assumes the foundation will be constructed neat against competent fill soil or backfilled with structural fill. The recommended lateral resistance value includes a safety factor of 1.5.

The soils exposed at foundation levels for the large multi-unit buildings should be observed by Terra Associates, Inc. If loose or medium stiff silts are present at planned footing grades, these silts should be overexcavated and be replaced with structural fill or as an alternative, the foundations may be stepped down to bear on the underlying dense glacially consolidated soils.

The following sections address foundation options for the northern buildings underlain by loose fills.

Steel Pipe Piles

If excavation and replacement of existing fills for the northern buildings is determined to be uneconomical or unfeasible, a suitable alternative for foundation support is to transfer building loads through the uncontrolled fill to the underlying very dense or hard bearing strata using four-inch diameter steel pipe piles. The pipe piles should be driven to refusal using a minimum 850 foot-pound impact hammer. Refusal is defined as less than one-inch of pile penetration during 15 seconds of continuous driving.

Based on data from the test pits, we anticipate pile tip elevations will range from 15 to 20 feet below existing grades. Pipe pile installation may encounter some obstructions, such as wood debris and roots. If an obstruction is encountered during driving, the pile location should be excavated, the obstruction removed, and the area then refilled to grade before re-driving. Alternatively, flexibility in pile location can be included in the design to allow for relocating the pile a short distance in an attempt to avoid the obstruction.

Four-inch diameter steel pipe piles driven to refusal will develop an allowable axial capacity of ten tons per pile. For resistance to lateral loading, a lateral pile capacity of one-fourth of a ton can be used for vertically-placed piles. Pipe piles may be battered to increase their ability to resist lateral loads. We expect pile settlements would not exceed one-fourth of an inch.

Ground Improvement

As an alternative to piles, consideration can be given to using ground other improvement techniques to establish suitable support for conventional spread footing designs. Methods that could be considered include vibrated stone columns or Geopiers (aggregate rammed piers). Both of these methods create highly densified columns of graded aggregate that would extend through the upper softer soils a short depth into the underlying dense sands. Because of the methods used to construct the columns some improvement of the adjacent soils is also realized. Once constructed, conventional spread footing foundations can be designed to bear immediately above the stone column/Geopier locations.

These ground improvement techniques are typically completed on a design/build approach with both design and construction completed by a specialty contractor. We can assist in contracting and selecting the specialty contractor, if desired.

5.6 Slab-on-Grade Construction

Slab-on-grade may be supported on competent undisturbed bearing surfaces consisting of the native dense drift soils or structural fill placed above competent native soils. If the existing fill is not removed from below the northern buildings the floors should also be structurally supported on piles.

Immediately below the floor slab, we recommend placing a four-inch thick capillary break layer composed of clean, coarse sand or fine gravel that has less than three percent passing the No. 200 sieve. This material will reduce the potential for upward capillary movement of water through the underlying soil and subsequent wetting of the floor slab.

The capillary break layer will not prevent moisture intrusion through the slab caused by water vapor transmission. Where moisture by vapor transmission is undesirable, such as covered floor areas, a common practice is to place a durable plastic membrane on the capillary break layer and then cover the membrane with a layer of clean sand or fine gravel to protect it from damage during construction, and aid in uniform curing of the concrete slab. It should be noted that if the sand or gravel layer overlying the membrane is saturated prior to pouring the slab, it will be ineffective in assisting uniform curing of the slab, and can actually serve as a water supply for moisture seeping through the slab and affecting floor coverings. Therefore, in our opinion, covering the membrane with a layer of sand or gravel should be avoided if floor slab construction occurs during the wet winter months and the layer cannot be effectively drained. We recommend floor designers and contractors refer to the 2003 American Concrete Institute (ACI) Manual of Concrete Practice, Part 2, 302.1R-96, for further information regarding vapor barrier installation below slab-on-grade floors.

5.7 Lateral Earth Pressure on Below-Grade Building Walls

The magnitude of earth pressure development on below-grade walls will partly depend on the quality of the wall backfill. We recommend placing and compacting wall backfill as structural fill as described in Section 5.2 of this report. To guard against hydrostatic pressure development, wall drainage must also be installed. A typical recommended wall drainage detail is shown on Figure 4.

With wall backfill placed and compacted as recommended, and drainage properly installed, we recommend designing unrestrained walls for an active earth pressure equivalent to a fluid weighing 35 pounds per cubic foot (pcf). For restrained walls, an additional uniform load of 100 psf should be added to the 35 pcf. To account for typical traffic surcharge loading, the walls can be designed for an additional imaginary height of two feet (two-foot soil surcharge). For evaluation of wall performance under seismic loading, a uniform pressure equivalent to $8H$ psf, where H is the height of the below-grade portion of the wall should be applied in addition to the static lateral earth pressure. These values assume a horizontal backfill condition and that no other surcharge loading, sloping embankments, or adjacent buildings will act on the wall. If such conditions exist, then the imposed loading must be included in the wall design. Friction at the base of foundations and passive earth pressure will provide resistance to these lateral loads. Values for these parameters are provided in Section 5.5 of this report.

5.8 Stormwater Detention Pond

As mentioned above, a stormwater pond is planned for the site. The proposed pond floor is between 11 and 15 feet below existing site grades and is formed by a combination of excavation, fill containment berm construction, and wall construction. The fill depths for the berm construction are between six and nine feet. Fill used to form containment berms for the detention ponds should consist of native silty sand with gravel placed and compacted as structural fill. Interior pond slopes below the stored water level should be graded at 3:1 with exterior pond slopes at 2:1.

Our field exploration indicates that the soils in the area of the pond consist of dense gravel with silt and sand. Heavy groundwater flow was observed near elevations 443 to 445 feet in the test pits located in the larger pond area which is currently below the proposed bottom of pond elevation of 447 feet. This groundwater elevation would be expected to rise during the normally wet winter season. While the soils encountered at this pond site exhibit permeability characteristics that would be suitable for infiltration considerations the elevated groundwater table would preclude designing the pond as a retention facility. However, if there is a dead storage water quality component in the pond design, lining the pond to prevent infiltration losses of the dead storage component will need to be considered.

5.9 Drainage

Surface

Final exterior grades should promote free and positive drainage away from the site at all times. Water must not be allowed to pond or collect adjacent to foundations or within the immediate building area. We recommend providing a positive drainage gradient away from the building perimeter. If this gradient cannot be provided, surface water should be collected adjacent to the structures and disposed to appropriate storm facilities.

Surface water must not be allowed to flow uncontrolled over the crest of the site slopes and embankments. Surface water should be directed away from the slope crests to a point of collection and controlled discharge. If site grades do not allow for directing surface water away from the slopes, then water should be collected and tightlined down the slope face in a controlled manner.

Subsurface

We recommend installing perimeter foundation drains adjacent to shallow foundations. The drains can be laid to grade at an invert elevation equivalent to the bottom of footing grade. The drains can consist of four-inch diameter perforated PVC pipe that is enveloped in washed pea gravel-sized drainage aggregate. The aggregate should extend six inches above and to the sides of the pipe. Roof and foundation drains should be tightlined separately to the storm drains. All drains should be provided with cleanouts at easily accessible locations.

Infiltration

The drift soils composed of silty sand with gravel, silt, and sandy silt characteristically exhibits low permeability and would not be a suitable receptor soil for discharge of development stormwater using infiltration/retention facilities. While there are deposits of cleaner outwash soils also present within the drift deposits their random distribution and limited thickness would preclude designing and using infiltration systems, in our opinion. Conventional stormwater detention with controlled release to the drainage basin should be used to manage development stormwater.

5.10 Utilities

Utility pipes should be bedded and backfilled in accordance with American Public Works Association (APWA) specifications. For site utilities within city rights of way, bedding and backfill should be completed in accordance with City of Puyallup specifications. At minimum, trench backfill should be placed and compacted as structural fill, as described in the Section 5.2 of this report. As noted, soils excavated on-site should be suitable for use as backfill material during dry weather conditions. However, the contractor should be prepared to moisture condition the soils to facilitate proper compaction, as necessary and import suitable material during the wet winter months.

5.11 Pavements

The pavement design section is dependent upon the supporting capability of the subgrade soils and the traffic conditions to which it will be subjected. All subgrade should be prepared in accordance with the recommendations in Section 5.2 of this report. For traffic consisting mainly of light passenger and commercial vehicles with only occasional heavy traffic, and with a stable subgrade prepared as recommended, we recommend the following pavement sections:

- Two inches of Hot Mix Asphalt (HMA) over four inches of crushed rock base (CRB)
- Four inches full depth HMA

The paving materials used should conform to the current Washington State Department of Transportation (WSDOT) specifications for HMA and CRB surfacing.

Long-term pavement performance will depend on surface drainage. A poorly-drained pavement section will be subject to premature failure as a result of surface water infiltrating into the subgrade soils and reducing their supporting capability. For optimum pavement performance, we recommend surface drainage gradients of at least two percent. Some degree of longitudinal and transverse cracking of the pavement surface should be expected over time. Regular maintenance should be planned to seal cracks when they occur.

6.0 ADDITIONAL SERVICES

Terra Associates, Inc. should review the final design and specifications in order to verify that earthwork and foundation recommendations have been properly interpreted and implemented in project design. We should also provide geotechnical services during construction in order to observe compliance with the design concepts, specifications, and recommendations. This will allow for design changes if subsurface conditions differ from those anticipated prior to the start of construction.

7.0 LIMITATIONS

This report is the property of Terra Associates, Inc. and was prepared in accordance with generally accepted geotechnical engineering practices. This report is intended for specific application to the Wesley Homes Puyallup project and for the exclusive use of Wesley Homes and their authorized representatives. No other warranty, expressed or implied, is made.

The analyses and recommendations presented in this report are based upon data obtained from the test pits excavated on-site. Variations in soil conditions can occur, the nature and extent of which may not become evident until construction. If variations appear evident, Terra Associates, Inc. should be requested to reevaluate the recommendations in this report prior to proceeding with construction.

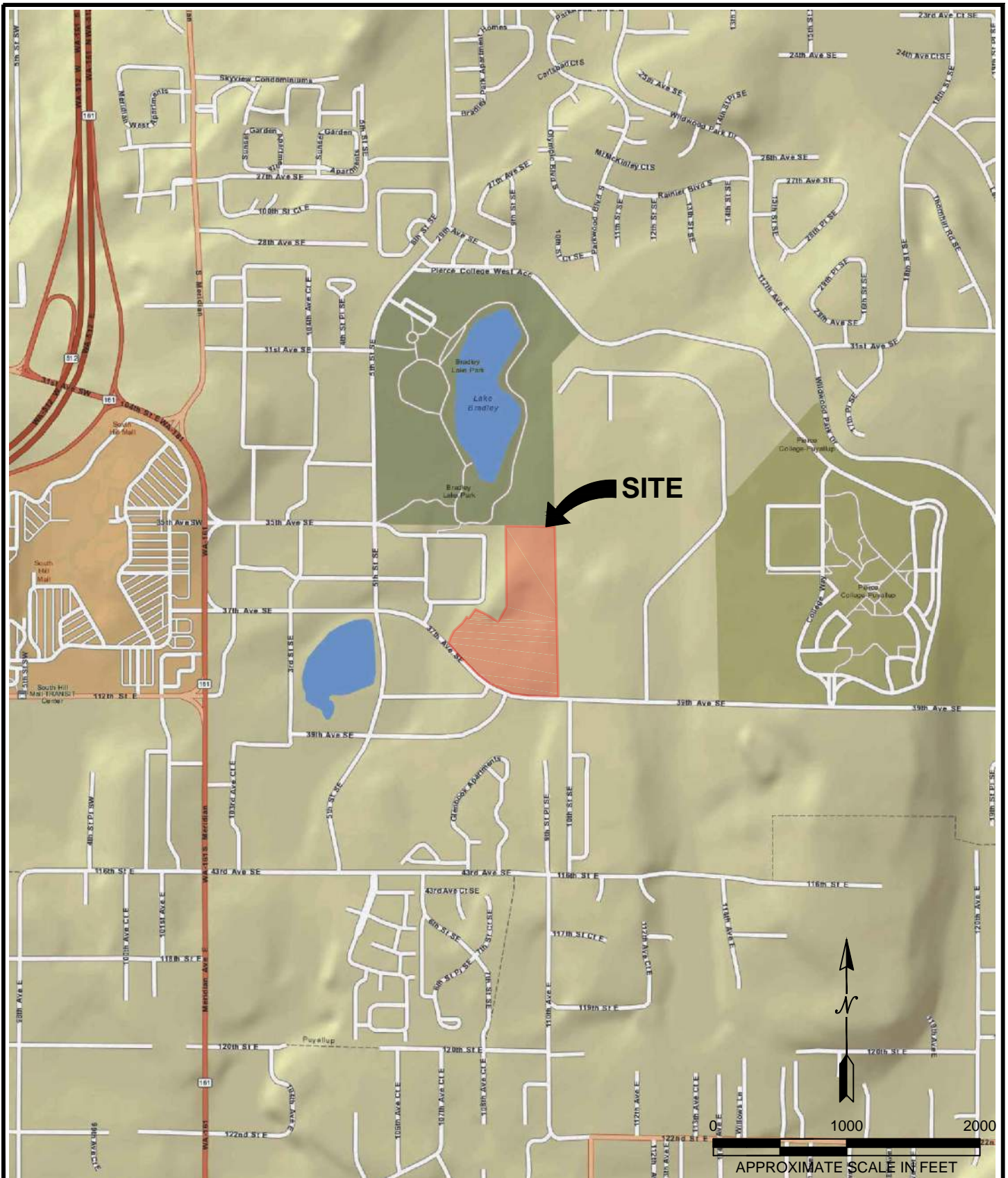

REFERENCE: <http://www.wsdot.wa.gov/data/tools/geoportal/>

ACCESSED 10/27/15

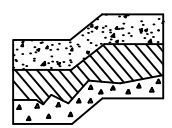

Terra Associates, Inc.
 Consultants in Geotechnical Engineering
 Geology and
 Environmental Earth Sciences

VICINITY MAP
 WESLEY HOMES PUYALLUP
 PUYALLUP, WASHINGTON

Proj. No. T-5915-3

Date NOV 2016

Figure 1

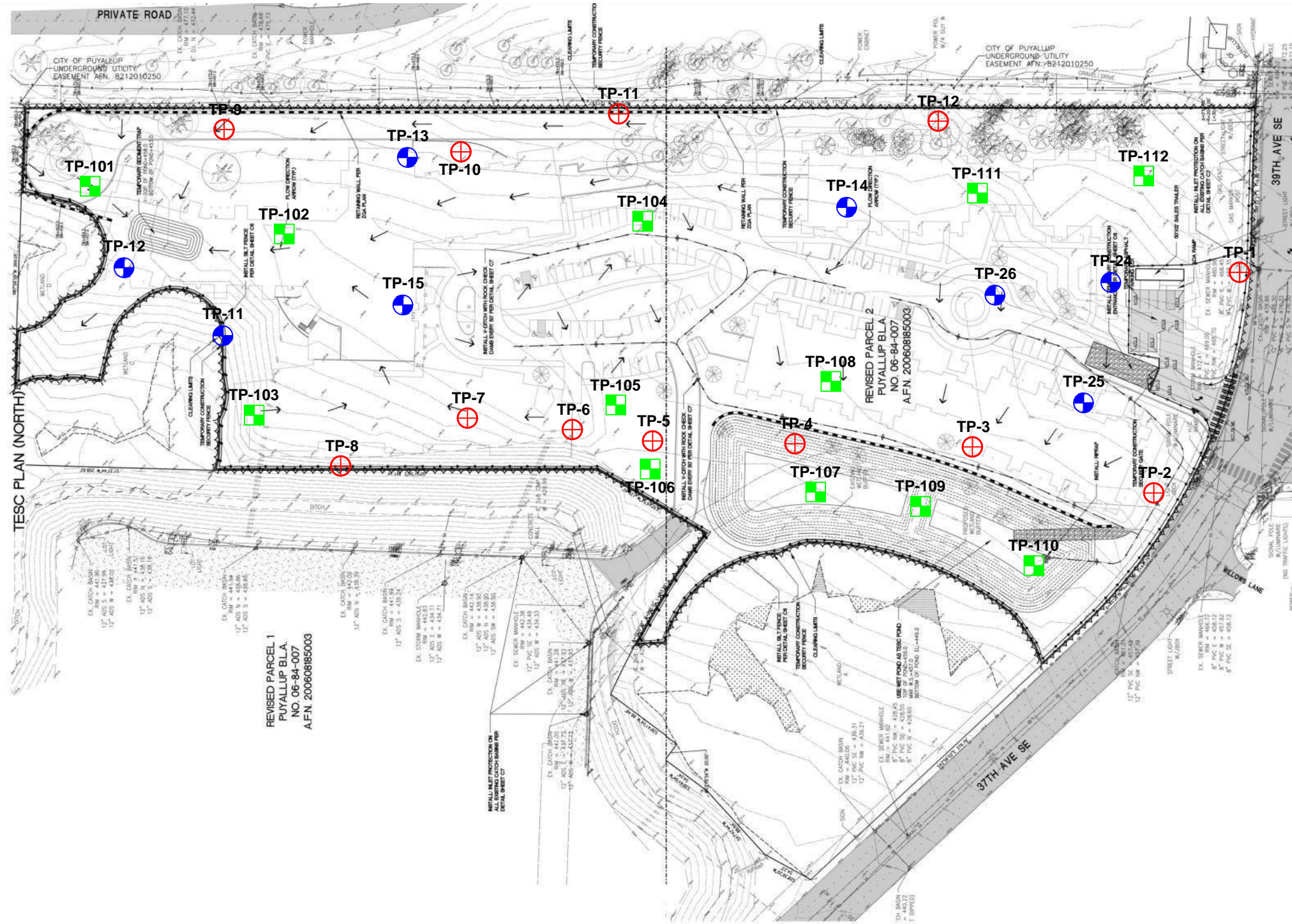



NOTE:

THIS SITE PLAN IS SCHEMATIC. ALL LOCATIONS AND DIMENSIONS ARE APPROXIMATE. IT IS INTENDED FOR REFERENCE ONLY AND SHOULD NOT BE USED FOR DESIGN OR CONSTRUCTION PURPOSES.

REFERENCE: SITE PLAN PROVIDED BY BARGHAUSEN.

LEGEND:

-  APPROXIMATE TEST PIT LOCATION (TERRA 2015)
-  APPROXIMATE TEST PIT LOCATION (GEO-ENGINEERS 2003)
-  APPROXIMATE TEST PIT LOCATION (TERRA ASSOCIATES 2006)

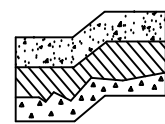

Terra Associates, Inc.
 Consultants in Geotechnical Engineering
 Geology and
 Environmental Earth Sciences

**EXPLORATION LOCATION PLAN
 WESLEY HOMES PUYALLUP
 PUYALLUP, WASHINGTON**

Proj. No. T-5915-3

Date NOV 2016

Figure 2

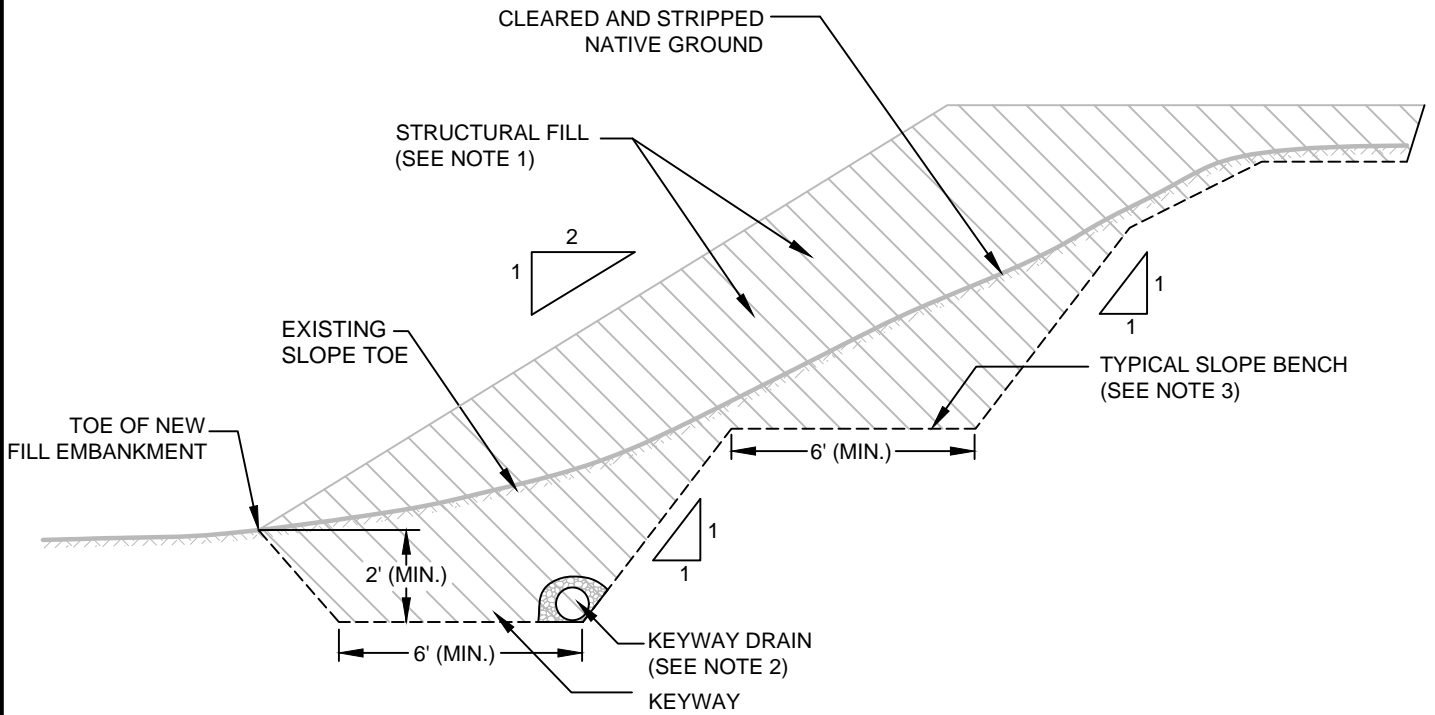

NOT TO SCALE

NOTES:

- 1) STRUCTURAL FILL SHALL BE COMPACTED TO A MINIMUM OF 95% OF ASTM D 698 MAXIMUM DRY DENSITY VALUE.
- 2) DRAINS SHALL CONSIST OF 6" DIA. PERFORATED PVC PIPE ENVELOPED IN 1 cu ft OF 3/4" WASHED GRAVEL. DRAIN PIPE SHALL BE DIRECTED TO THE STORM DRAIN SYSTEM OR APPROVED POINT OF DISCHARGE.
- 3) ADDITIONAL BENCHES AND BENCH DRAINS MAY BE REQUIRED BASED ON FIELD EVALUATION BY THE GEOTECHNICAL ENGINEER.

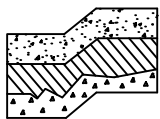

Terra Associates, Inc.
 Consultants in Geotechnical Engineering
 Geology and
 Environmental Earth Sciences

**TYPICAL SLOPE KEY AND BENCH DETAIL
 WESLEY HOMES PUYALLUP
 PUYALLUP, WASHINGTON**

Proj. No.T-5915-3

Date NOV 2016

Figure 3

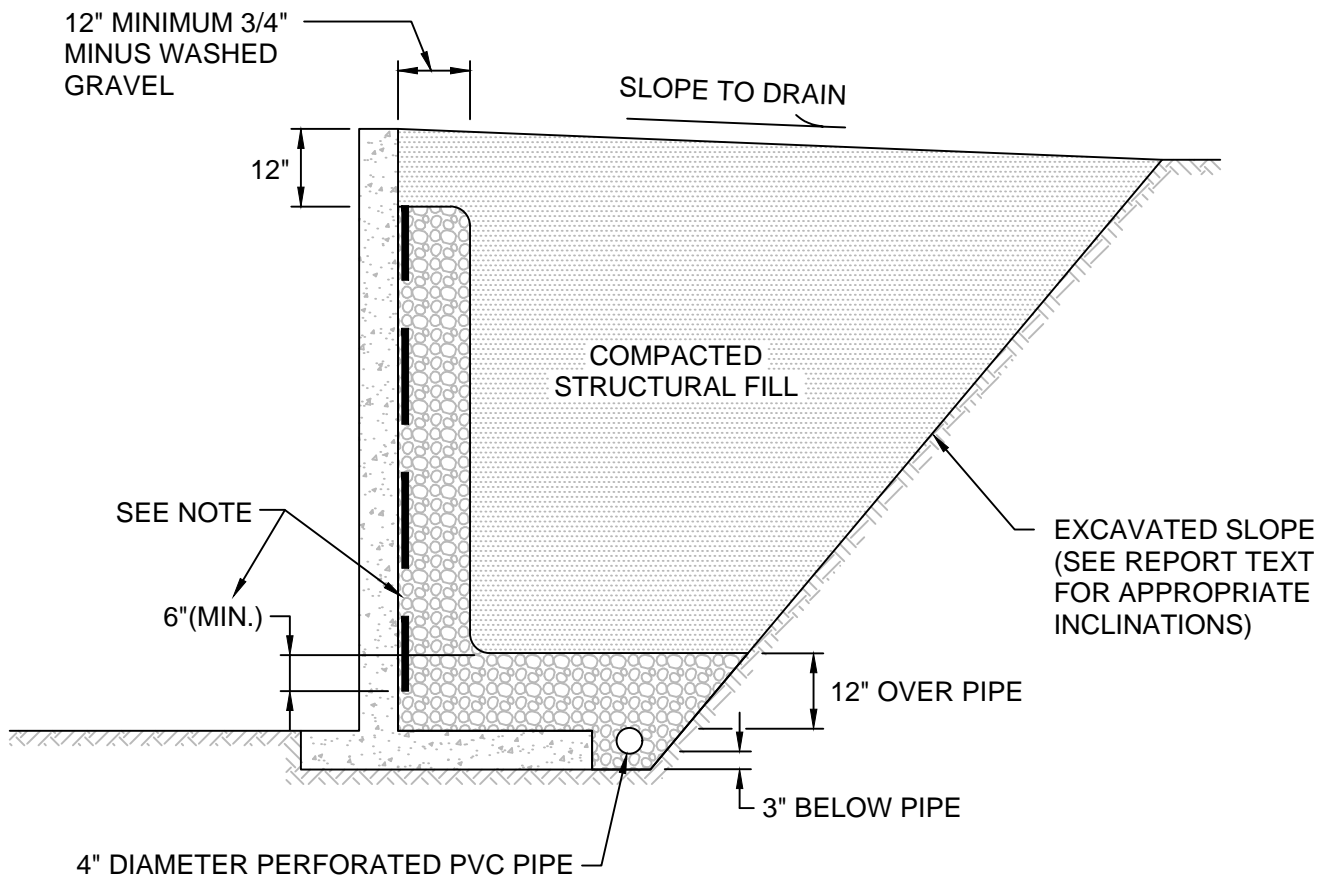

NOT TO SCALE

NOTE:

MIRADRAIN G100N PREFABRICATED DRAINAGE PANELS OR SIMILAR PRODUCT CAN BE SUBSTITUTED FOR THE 12-INCH WIDE GRAVEL DRAIN BEHIND WALL. DRAINAGE PANELS SHOULD EXTEND A MINIMUM OF SIX INCHES INTO 12-INCH THICK DRAINAGE GRAVEL LAYER OVER PERFORATED DRAIN PIPE.

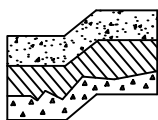

Terra Associates, Inc.
 Consultants in Geotechnical Engineering
 Geology and
 Environmental Earth Sciences

TYPICAL WALL DRAINAGE DETAIL
 WESLEY HOMES PUYALLUP
 PUYALLUP, WASHINGTON

Proj. No. T-5915-3

Date OCT 2015

Figure 4

APPENDIX A
FIELD EXPLORATION AND LABORATORY TESTING

Wesley Homes Puyallup
Puyallup, Washington



On October 13, 2015, we completed our site exploration by observing soil and groundwater conditions at 12 test pits. The test pits were excavated using a track-mounted excavator to a maximum depth of 15 feet below existing site grades. Test pit locations were determined in the field by using GPS coordinates from Google Earth. The approximate location of the test pits is shown on the attached Exploration Location Plan, Figure 2. Test Pit Logs are attached as Figures A-2 through A-13.

A geotechnical engineer from our office conducted the field exploration. Our representative classified the soil conditions encountered, maintained a log of each test pit, obtained representative soil samples, and recorded water levels observed during excavation. All soil samples were visually classified in accordance with the Unified Soil Classification System (USCS) described on Figure A-1.

Representative soil samples obtained from the test pits and test borings were placed in closed containers and taken to our laboratory for further examination and testing. The moisture content of each sample was measured and is reported on the individual Test Boring Logs. Grain size analyses were performed on selected samples. The results of the grain size analyses are shown on Figures A-14 and A-15.

MAJOR DIVISIONS			LETTER SYMBOL	TYPICAL DESCRIPTION	
COARSE GRAINED SOILS	More than 50% material larger than No. 200 sieve size	GRAVELS More than 50% of coarse fraction is larger than No. 4 sieve	Clean Gravels (less than 5% fines)	GW	Well-graded gravels, gravel-sand mixtures, little or no fines.
				GP	Poorly-graded gravels, gravel-sand mixtures, little or no fines.
			Gravels with fines	GM	Silty gravels, gravel-sand-silt mixtures, non-plastic fines.
				GC	Clayey gravels, gravel-sand-clay mixtures, plastic fines.
	More than 50% material smaller than No. 200 sieve size	SANDS More than 50% of coarse fraction is smaller than No. 4 sieve	Clean Sands (less than 5% fines)	SW	Well-graded sands, sands with gravel, little or no fines.
				SP	Poorly-graded sands, sands with gravel, little or no fines.
			Sands with fines	SM	Silty sands, sand-silt mixtures, non-plastic fines.
				SC	Clayey sands, sand-clay mixtures, plastic fines.
FINE GRAINED SOILS	SILTS AND CLAYS Liquid Limit is less than 50%		ML	Inorganic silts, rock flour, clayey silts with slight plasticity.	
			CL	Inorganic clays of low to medium plasticity. (Lean clay)	
			OL	Organic silts and organic clays of low plasticity.	
	SILTS AND CLAYS Liquid Limit is greater than 50%		MH	Inorganic silts, elastic.	
			CH	Inorganic clays of high plasticity. (Fat clay)	
			OH	Organic clays of high plasticity.	
HIGHLY ORGANIC SOILS			PT	Peat.	

DEFINITION OF TERMS AND SYMBOLS

COHESIONLESS	<u>Density</u>	<u>Standard Penetration Resistance in Blows/Foot</u>	 2" OUTSIDE DIAMETER SPILT SPOON SAMPLER  2.4" INSIDE DIAMETER RING SAMPLER OR SHELBY TUBE SAMPLER  WATER LEVEL (Date) Tr TORVANE READINGS, tsf
	Very Loose	0-4	
COHESIVE	<u>Consistency</u>	<u>Standard Penetration Resistance in Blows/Foot</u>	Pp PENETROMETER READING, tsf DD DRY DENSITY, pounds per cubic foot LL LIQUID LIMIT, percent PI PLASTIC INDEX N STANDARD PENETRATION, blows per foot
	Loose	4-10	
	Medium Dense	10-30	
	Dense	30-50	
	Very Dense	>50	
	Very Soft	0-2	
	Soft	2-4	
	Medium Stiff	4-8	
	Stiff	8-16	
	Very Stiff	16-32	
	Hard	>32	

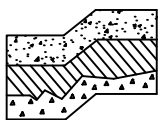

Terra Associates, Inc.
 Consultants in Geotechnical Engineering
 Geology and Environmental Earth Sciences

**UNIFIED SOIL CLASSIFICATION SYSTEM
 WESLEY HOMES PUYALLUP
 PUYALLUP, WASHINGTON**

Proj. No.T-5915-3

Date NOV 2016

Figure A-1

LOG OF TEST PIT NO. TP-101

FIGURE A-2

PROJECT NAME: Wesley Homes Puyallup PROJ. NO: T-5915-3 LOGGED BY: CSD
 LOCATION: Puyallup, Washington SURFACE CONDS: Tall Understory APPROX. ELEV: 456 +/- Ft.
 DATE LOGGED: October 13, 2015 DEPTH TO GROUNDWATER: N/A DEPTH TO CAVING: N/A

DEPTH (FT.)	SAMPLE NO.	DESCRIPTION	CONSISTENCY/ RELATIVE DENSITY	W (%)	POCKET PEN. (TSF)	REMARKS
1		Black silty SAND, fine grained, moist, heavy organic inclusions. (SM) (TOPSOIL)	Loose			
2	1	Brown SAND with silty and gravel, fine to medium grained, dry, roots. (SP-SM)	Medium Dense	8.1		
3						
4						
5		Gray silty SAND with gravel, fine to medium grained, moist, cemented. (SM)	Dense			
6	2			6.7		
7						
8						
9		Brown SAND with gravel, medium to coarse grained, moist. (SP)	Dense			
10	3			5.5		
11		Test pit terminated at approximately 10 feet. No groundwater seepage observed.				
12						
13						
14						
15						

NOTE: This subsurface information pertains only to this test pit location and should not be interpreted as being indicative of other locations at the site.



Terra Associates, Inc.
 Consultants in Geotechnical Engineering
 Geology and
 Environmental Earth Sciences

LOG OF TEST PIT NO. TP-102

FIGURE A-3

PROJECT NAME: Wesley Homes Puyallup PROJ. NO: T-5915-3 LOGGED BY: CSD
 LOCATION: Puyallup, Washington SURFACE CONDS: Low Grass/Weeds APPROX. ELEV: 458 +/- Ft.
 DATE LOGGED: October 13, 2015 DEPTH TO GROUNDWATER: N/A DEPTH TO CAVING: N/A

DEPTH (FT.)	SAMPLE NO.	DESCRIPTION	CONSISTENCY/ RELATIVE DENSITY	W (%)	POCKET PEN. (TSF)	REMARKS
1	1	(2 inches ORGANICS) Red-brown SAND with silt and gravel, fine to medium grained, moist. (SP-SM)	Medium Dense	3.1		
2						
3						
4		Gray SAND with gravel to GRAVEL with sand, medium to coarse grained, dry. (SP/GP)	Medium Dense			
5						
6	2			36.9		
7						
8	3	Gray SILT, fine grained, moist, very small sand interbeds, upper two feet mottled.	Medium Stiff	36.8		
9						
10		LL=35 PL=26 PI=9				
11						
12		Brown SAND with silt and gravel to GRAVEL with silt and sand, medium to coarse grained, wet to saturated. (SP-SM/GP-GM)	Dense			
13	4			12.1		
14		Test pit terminated at approximately 13 feet. No groundwater seepage observed.				
15						

NOTE: This subsurface information pertains only to this test pit location and should not be interpreted as being indicative of other locations at the site.



Terra Associates, Inc.
 Consultants in Geotechnical Engineering
 Geology and
 Environmental Earth Sciences

LOG OF TEST PIT NO. TP-103

FIGURE A-4

PROJECT NAME: Wesley Homes Puyallup PROJ. NO: T-5915-3 LOGGED BY: CSD
 LOCATION: Puyallup, Washington SURFACE CONDS: Tall Blackberries APPROX. ELEV: 451 +/- Ft.
 DATE LOGGED: October 13, 2015 DEPTH TO GROUNDWATER: N/A DEPTH TO CAVING: N/A

DEPTH (FT.)	SAMPLE NO.	DESCRIPTION	CONSISTENCY/ RELATIVE DENSITY	W (%)	POCKET PEN. (TSF)	REMARKS
1	1	(6 inches ORGANICS)		10.4		
2						
3						
4						
5	2			18.5		
6		FILL: black with some brown and gray silty sand with gravel and sand with silt and gravel, fine to medium grained, moist, heavy organic inclusions including large logs and cut wood.	Medium Dense			
7						
8						
9						
10						
11						
12						
13						
14						
15	3			Gray silty SAND, fine to medium grained, wet. (SM)	Medium Dense	21.2
16		Test pit terminated at approximately 15 feet. No groundwater seepage observed.				
17						
18						
19						
20						

NOTE: This subsurface information pertains only to this test pit location and should not be interpreted as being indicative of other locations at the site.



Terra Associates, Inc.
 Consultants in Geotechnical Engineering
 Geology and
 Environmental Earth Sciences

LOG OF TEST PIT NO. TP-104

FIGURE A-5

PROJECT NAME: Wesley Homes Puyallup PROJ. NO: T-5915-3 LOGGED BY: CSD
 LOCATION: Puyallup, Washington SURFACE CONDS: Tall Brush APPROX. ELEV: 458 +/- Ft.
 DATE LOGGED: October 13, 2015 DEPTH TO GROUNDWATER: N/A DEPTH TO CAVING: N/A

DEPTH (FT.)	SAMPLE NO.	DESCRIPTION	CONSISTENCY/ RELATIVE DENSITY	W (%)	POCKET PEN. (TSF)	REMARKS
1	1	(8 inches ORGANICS) Brown SAND with silt and gravel to silty SAND with gravel, fine to medium grained, dry.	Medium Dense	10.4		
2			Medium Dense			
3			Medium Dense			
4	2			6.5		
5		Gray silty GRAVEL with sand to silty SAND with gravel, fine to medium grained, moist, some cobbles. (GM/SM)	Dense			
6						
7						
8						
9						
10		Gray SAND with silt and gravel, fine to coarse grained, wet. (SP-SM)	Dense			
11	3			11.0		
12		Test pit terminated at approximately 11 feet. No groundwater seepage observed.				
13						
14						
15						

NOTE: This subsurface information pertains only to this test pit location and should not be interpreted as being indicative of other locations at the site.



Terra Associates, Inc.
 Consultants in Geotechnical Engineering
 Geology and
 Environmental Earth Sciences

LOG OF TEST PIT NO. TP-105

FIGURE A-6

PROJECT NAME: Wesley Homes Puyallup PROJ. NO: T-5915-3 LOGGED BY: CSD
 LOCATION: Puyallup, Washington SURFACE CONDS: Tall Blackberries APPROX. ELEV: 454 +/- Ft.
 DATE LOGGED: October 13, 2015 DEPTH TO GROUNDWATER: N/A DEPTH TO CAVING: N/A

DEPTH (FT.)	SAMPLE NO.	DESCRIPTION	CONSISTENCY/ RELATIVE DENSITY	W (%)	POCKET PEN. (TSF)	REMARKS
1	1	(8 inches ORGANICS)		8.4		
2		Brown SAND with silt and gravel, fine to coarse grained, dry to moist, roots. (SP-SM)	Medium Dense			
3						
4	2			3.7		
5						
6						
7	3	Gray SILT, fine grained, moist, upper two feet mottled. (ML)	Medium Stiff to Stiff	19.8		
8						
9						
10	4			19.4		
11		Test pit terminated at approximately 10.5 feet. No groundwater seepage observed.				
12						
13						
14						
15						

NOTE: This subsurface information pertains only to this test pit location and should not be interpreted as being indicative of other locations at the site.



Terra Associates, Inc.
 Consultants in Geotechnical Engineering
 Geology and
 Environmental Earth Sciences

LOG OF TEST PIT NO. TP-106

FIGURE A-7

PROJECT NAME: Wesley Homes Puyallup PROJ. NO: T-5915-3 LOGGED BY: CSD
 LOCATION: Puyallup, Washington SURFACE CONDS: Tall Grass APPROX. ELEV: 452 +/- Ft.
 DATE LOGGED: October 13, 2015 DEPTH TO GROUNDWATER: N/A DEPTH TO CAVING: N/A

DEPTH (FT.)	SAMPLE NO.	DESCRIPTION	CONSISTENCY/ RELATIVE DENSITY	W (%)	POCKET PEN. (TSF)	REMARKS
1		(8 inches ORGANICS)				
	1			6.6		
2		Gray SAND, fine grained, moist, some silt and gravel. (SP)	Medium Dense			
3						
4						
5	2			18.8		
6						
7						
	3	Gray SILT, fine grained, moist, upper two feet mottled. (ML)	Medium Stiff to Very Stiff	30.1		
8						
9						
10	4	Brown silty SAND with gravel, fine to medium grained, moist to wet. (SM)	Dense	13.1		
11		Test pit terminated at approximately 10.5 feet. No groundwater seepage observed.				
12						
13						
14						
15						

NOTE: This subsurface information pertains only to this test pit location and should not be interpreted as being indicative of other locations at the site.



Terra Associates, Inc.
 Consultants in Geotechnical Engineering
 Geology and
 Environmental Earth Sciences

LOG OF TEST PIT NO. TP-107

FIGURE A-8

PROJECT NAME: Wesley Homes Puyallup PROJ. NO: T-5915-3 LOGGED BY: CSD
 LOCATION: Puyallup, Washington SURFACE CONDS: Forest Duff APPROX. ELEV: 452 +/- Ft.
 DATE LOGGED: October 13, 2015 DEPTH TO GROUNDWATER: 7 Feet DEPTH TO CAVING: N/A

DEPTH (FT.)	SAMPLE NO.	DESCRIPTION	CONSISTENCY/ RELATIVE DENSITY	W (%)	POCKET PEN. (TSF)	REMARKS
1		Dark brown silty SAND, fine to medium grained, moist. (SM) (TOPSOIL)	Loose			
2						
3	1	Gray silty SAND, fine grained, moist, roots. (SM)	Medium Dense	12.1		
4						
5						
6						
7	2	Brown SAND with silt, medium to coarse grained, wet to saturated. (SP-SM)	Medium Dense	21.7		
8						
9						
10	3	Brown GRAVEL with silt and sand, medium to coarse grained, saturated. (GP-GM)	Dense	8.3		
11		Test pit terminated at approximately 10 feet. Heavy groundwater seepage observed at 7 feet.				
12						
13						
14						
15						

NOTE: This subsurface information pertains only to this test pit location and should not be interpreted as being indicative of other locations at the site.



Terra Associates, Inc.
 Consultants in Geotechnical Engineering
 Geology and
 Environmental Earth Sciences

LOG OF TEST PIT NO. TP-108

FIGURE A-9

PROJECT NAME: Wesley Homes Puyallup PROJ. NO: T-5915-3 LOGGED BY: CSD
 LOCATION: Puyallup, Washington SURFACE CONDS: Tall Understory APPROX. ELEV: 456 +/- Ft.
 DATE LOGGED: October 13, 2015 DEPTH TO GROUNDWATER: N/A DEPTH TO CAVING: N/A

DEPTH (FT.)	SAMPLE NO.	DESCRIPTION	CONSISTENCY/ RELATIVE DENSITY	W (%)	POCKET PEN. (TSF)	REMARKS
1	1	(8 inches ORGANICS)		7.2		
2			Medium Dense			
3		Brown to gray silty SAND to silty SAND with gravel, fine grained, moist, some cementation. (SM)				
4			Dense			
6	2			9.3		
7						
8	3			8.4		
9		Gray SAND with silt and gravel, medium to coarse grained, moist to wet. (SP-SM)				
10	4		Dense	13.9		
11		Test pit terminated at approximately 11 feet. No groundwater seepage observed.				
12						
13						
14						
15						

NOTE: This subsurface information pertains only to this test pit location and should not be interpreted as being indicative of other locations at the site.



Terra Associates, Inc.
 Consultants in Geotechnical Engineering
 Geology and
 Environmental Earth Sciences

LOG OF TEST PIT NO. TP-109

FIGURE A-10

PROJECT NAME: Wesley Homes Puyallup PROJ. NO: T-5915-3 LOGGED BY: CSD
 LOCATION: Puyallup, Washington SURFACE CONDS: Tall Brush APPROX. ELEV: 454 +/- Ft.
 DATE LOGGED: October 13, 2015 DEPTH TO GROUNDWATER: 11.5 Feet DEPTH TO CAVING: N/A

DEPTH (FT.)	SAMPLE NO.	DESCRIPTION	CONSISTENCY/ RELATIVE DENSITY	W (%)	POCKET PEN. (TSF)	REMARKS
1	1	(8 inches ORGANICS)		15.1		
2		Gray sandy SILT to silty SAND, fine grained, moist. (ML/SM)	Medium Dense			
3						
4						
5	2			5.8		
6						
7		Brown GRAVEL with sand, fine to medium grained, moist. (GP)	Medium Dense			
8						
9	3			8.0		
10						
11		Brown GRAVEL with silt and sand, medium to coarse grained, moist to saturated. (GP-GM)	Dense			
12	4			13.4		
13		Test pit terminated at approximately 12 feet. Heavy groundwater seepage observed at 11.5 feet.				
14						
15						

NOTE: This subsurface information pertains only to this test pit location and should not be interpreted as being indicative of other locations at the site.



Terra Associates, Inc.
 Consultants in Geotechnical Engineering
 Geology and
 Environmental Earth Sciences

LOG OF TEST PIT NO. TP-110

FIGURE A-11

PROJECT NAME: Wesley Homes Puyallup PROJ. NO: T-5915-3 LOGGED BY: CSD
 LOCATION: Puyallup, Washington SURFACE CONDS: Tall Understory APPROX. ELEV: 454 +/- Ft.
 DATE LOGGED: October 13, 2015 DEPTH TO GROUNDWATER: 11 Feet DEPTH TO CAVING: N/A

DEPTH (FT.)	SAMPLE NO.	DESCRIPTION	CONSISTENCY/ RELATIVE DENSITY	W (%)	POCKET PEN. (TSF)	REMARKS
1		(8 inches ORGANICS)				
1	1	Gray SILT with sand, fine grained, moist, upper two feet mottled, trace gravel. (ML)	Medium Dense	14.8		
2						
3				4.9		
4	2	Brown GRAVEL with silt and sand, fine to coarse grained, moist. (GP-GM)				
5						
6		*At 6 feet soil becomes wet.				
7	3		Medium Dense	12.1		
8						
9						
10						
11		Test pit terminated at approximately 11 feet. Heavy groundwater seepage observed at 11 feet.				
12						
13						
14						
15						

NOTE: This subsurface information pertains only to this test pit location and should not be interpreted as being indicative of other locations at the site.



Terra Associates, Inc.
 Consultants in Geotechnical Engineering
 Geology and
 Environmental Earth Sciences

LOG OF TEST PIT NO. TP-111

FIGURE A-12

PROJECT NAME: Wesley Homes Puyallup PROJ. NO: T-5915-3 LOGGED BY: CSD
 LOCATION: Puyallup, Washington SURFACE CONDS: Tall Understory APPROX. ELEV: 466 +/- Ft.
 DATE LOGGED: October 13, 2015 DEPTH TO GROUNDWATER: N/A DEPTH TO CAVING: N/A

DEPTH (FT.)	SAMPLE NO.	DESCRIPTION	CONSISTENCY/ RELATIVE DENSITY	W (%)	POCKET PEN. (TSF)	REMARKS
1		Dark brown silty SAND, fine grained, moist, heavy organic inclusions. (SM) (TOPSOIL)	Loose			
2		Brown silty SAND with gravel, fine to medium grained, moist. (SM)	Medium Dense	12.6		
3	1					
4						
5		Gray silty SAND with gravel, fine to medium grained, moist, upper two feet mottled, occasional cobble/boulder. (SM)	Medium Dense	11.4		
6	2					
7						
8						
9		Test pit terminated at approximately 11 feet. No groundwater seepage observed.				
10	3					
11						
12						
13						
14						
15						

NOTE: This subsurface information pertains only to this test pit location and should not be interpreted as being indicative of other locations at the site.



Terra Associates, Inc.
 Consultants in Geotechnical Engineering
 Geology and
 Environmental Earth Sciences

LOG OF TEST PIT NO. TP-112

FIGURE A-13

PROJECT NAME: Wesley Homes Puyallup PROJ. NO: T-5915-3 LOGGED BY: CSD
 LOCATION: Puyallup, Washington SURFACE CONDS: Forest Duff APPROX. ELEV: 474 +/- Ft.
 DATE LOGGED: October 13, 2015 DEPTH TO GROUNDWATER: N/A DEPTH TO CAVING: N/A

DEPTH (FT.)	SAMPLE NO.	DESCRIPTION	CONSISTENCY/ RELATIVE DENSITY	W (%)	POCKET PEN. (TSF)	REMARKS
1		Dark brown silty SAND, fine grained, moist, heavy organic inclusions. (SM) (TOPSOIL)	Loose			
2	1	Red-brown to brown SAND with silt and gravel to silty SAND with gravel, fine to medium grained, dry. (SP-SM/SM)	Medium Dense	7.6		
3						
4						
5	2	Brown GRAVEL with sand, medium to coarse grained, dry. (GP)	Medium Dense	1.9		
6						
7						
8						
9	3	Gray silty SAND with gravel, fine to medium grained, moist. (SM)	Dense	5.8		
10						
11		Test pit terminated at approximately 10 feet. No groundwater seepage observed.				
12						
13						
14						
15						

NOTE: This subsurface information pertains only to this test pit location and should not be interpreted as being indicative of other locations at the site.



Terra Associates, Inc.
 Consultants in Geotechnical Engineering
 Geology and
 Environmental Earth Sciences

Particle Size Distribution Report

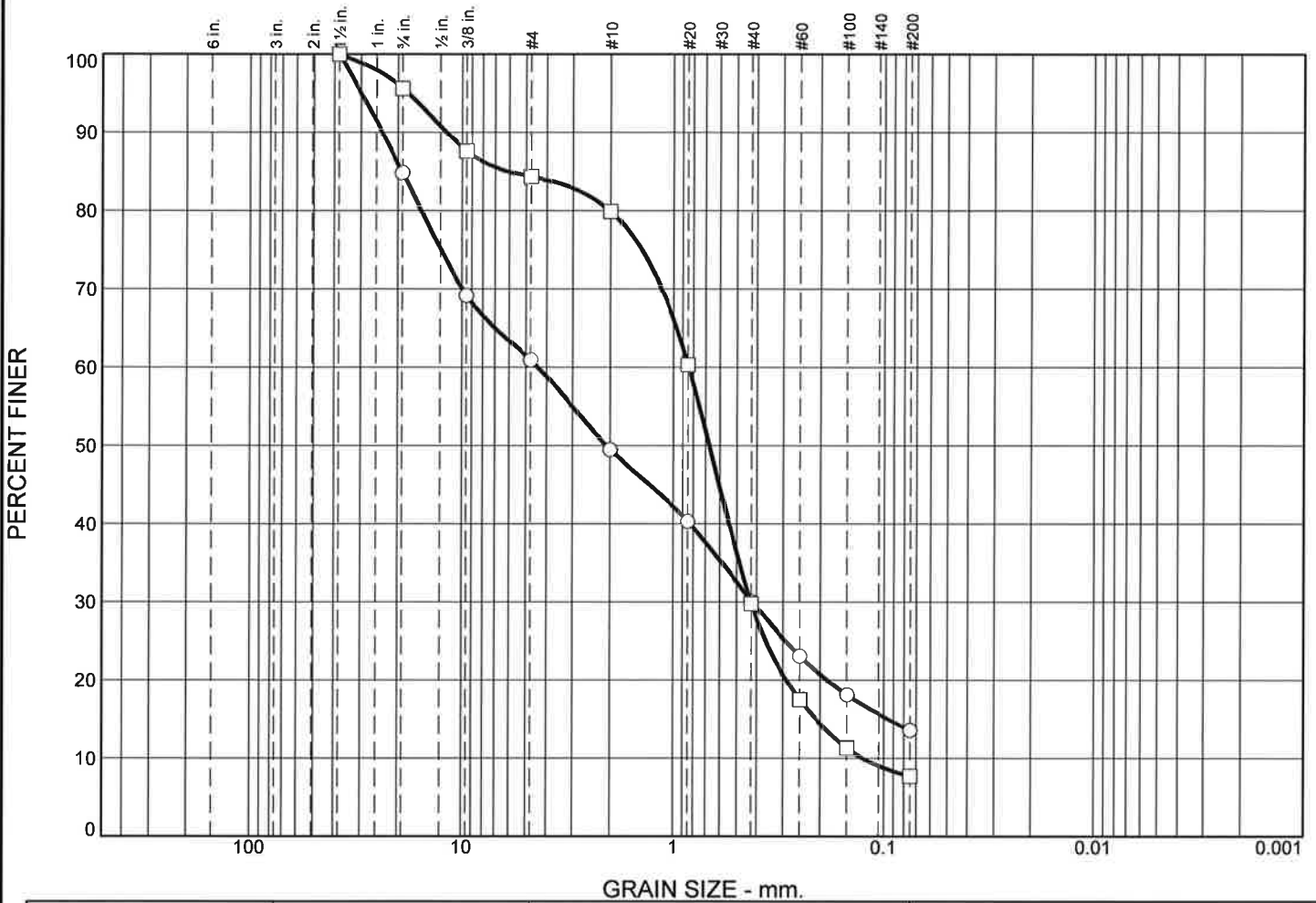

	% +3"	% Gravel		% Sand			% Fines	
		Coarse	Fine	Coarse	Medium	Fine	Silt	Clay
○	0.0	15.2	23.9	11.4	19.4	16.5	13.6	
□	0.0	4.4	11.3	4.4	50.1	22.1	7.7	

	LL	PL	D85	D60	D50	D30	D15	D10	Cc	Cu
○			19.2109	4.4000	2.0841	0.4221	0.0955			
□			6.0908	0.8436	0.6729	0.4274	0.2101	0.1259	1.72	6.70

Material Description	USCS	AASHTO
○ Silty SAND with gravel	SM	
□ Well graded SAND with silt and gravel	SW-SM	

<p>Project No. T-5915-3 Client: Wesley Homes</p> <p>Project: Wesley Homes Puyallup Puyallup, Washington</p> <p>○ Location: Test Pit TP-101 Depth: -5.5 feet Sample Number: 2</p> <p>□ Location: Test Pit TP-105 Depth: -1.5 feet Sample Number: 1</p>	<p>Remarks:</p> <p>○ Tested on 10/15/2015</p> <p>□ Tested on 10/15/2015</p>
<p>Terra Associates, Inc.</p> <p>Kirkland, WA</p>	

Figure A-14

Tested By: FQ

Particle Size Distribution Report

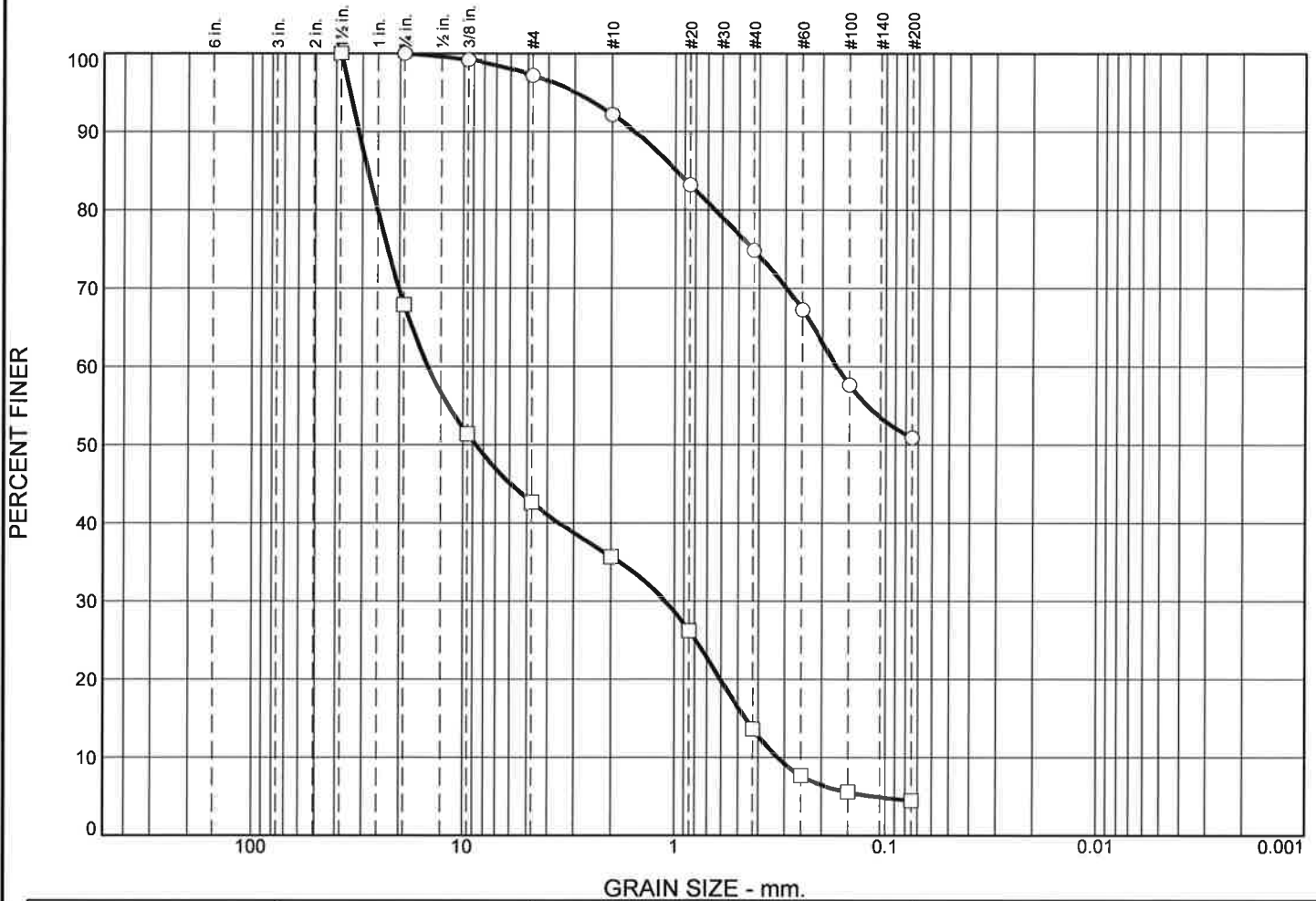

	% +3"	% Gravel		% Sand			% Fines	
		Coarse	Fine	Coarse	Medium	Fine	Silt	Clay
○	0.0	0.0	2.8	5.0	17.4	23.9	50.9	
□	0.0	32.1	25.3	6.9	22.1	9.1	4.5	

	LL	PL	D ₈₅	D ₆₀	D ₅₀	D ₃₀	D ₁₅	D ₁₀	C _c	C _u
○			0.9912	0.1722						
□			28.3351	14.6713	8.7037	1.1078	0.4626	0.3242	0.26	45.25

Material Description	USCS	AASHTO
○ Sandy SILT	ML	
□ Poorly graded GRAVEL with sand	GP	

<p>Project No. T-5915-3 Client: Wesley Homes</p> <p>Project: Wesley Homes Puyallup Puyallup, Washington</p> <p>○ Location: Test Pit TP-109 Depth: -1 foot Sample Number: 1</p> <p>□ Location: Test Pit TP-109 Depth: -8.5 feet Sample Number: 3</p> <p style="text-align: center;">Terra Associates, Inc.</p> <p style="text-align: center;">Kirkland, WA</p>	<p>Remarks:</p> <p>○ Tested on 10/15/2015</p> <p>□ Tested on 10/15/2015</p>
---	--

Figure A-15

Tested By: FQ

APPENDIX B

PREVIOUS TEST PIT LOGS

LOG OF TEST PIT NO. 1

FIGURE A-2

PROJECT NAME: Puyallup Senior Housing Project PROJ. NO: T-5915-1 LOGGED BY: TA
 LOCATION: Puyallup, Washington SURFACE CONDS: _____ ELEV: 474
 DATE LOGGED: August 3, 2006 DEPTH TO GROUNDWATER: N/A DEPTH TO CAVING: N/A

DEPTH (FT.)	SAMPLE NO.	DESCRIPTION	CONSISTENCY/ RELATIVE DENSITY	W (%)	POCKET PEN. (TSF)	REMARKS
5		(9 inches TOPSOIL) Brown sandy GRAVEL, dry. (GP) Moist below 5 feet.	Dense	2.5		
10		Brown sandy GRAVEL, dry. (GP)	Dense	5.3		
15		Test pit terminated at 11 feet. No groundwater seepage was observed. No caving was observed.				

NOTE: This subsurface information pertains only to this test pit location and should not be interpreted as being indicative of other locations at the site.



Terra Associates, Inc.
 Consultants in Geotechnical Engineering
 Geology and
 Environmental Earth Sciences

LOG OF TEST PIT NO. 2

FIGURE A-3

PROJECT NAME: Puyallup Senior Housing Project PROJ. NO: T-5915-1 LOGGED BY: TA

LOCATION: Puyallup, Washington SURFACE CONDS: _____ ELEV: 458

DATE LOGGED: August 3, 2006 DEPTH TO GROUNDWATER: N/A DEPTH TO CAVING: N/A

DEPTH (FT.)	SAMPLE NO.	DESCRIPTION	CONSISTENCY/ RELATIVE DENSITY	W (%)	POCKET PEN. (TSF)	REMARKS
5		(6 inches TOPSOIL) Brown silty SAND, moist to dry. (SM) Very dense below 5 feet.	Medium Dense	8.3 11.4		
10		Brown gravelly SAND, dry. (SP)	Very Dense	4.5		
15		Test pit terminated at 10 feet. No groundwater seepage was observed. No caving was observed.				

NOTE: This subsurface information pertains only to this test pit location and should not be interpreted as being indicative of other locations at the site.



Terra Associates, Inc.
 Consultants in Geotechnical Engineering
 Geology and
 Environmental Earth Sciences

LOG OF TEST PIT NO. 3

FIGURE A-4

PROJECT NAME: Puyallup Senior Housing Project PROJ. NO: T-5915-1 LOGGED BY: TA
 LOCATION: Puyallup, Washington SURFACE CONDS: _____ ELEV: 458
 DATE LOGGED: August 3, 2006 DEPTH TO GROUNDWATER: N/A DEPTH TO CAVING: N/A

DEPTH (FT.)	SAMPLE NO.	DESCRIPTION	CONSISTENCY/ RELATIVE DENSITY	W (%)	POCKET PEN. (TSF)	REMARKS
		(12 inches TOPSOIL)				
		Brown sandy SILT with gravels, oxidallon staining, moist. (ML)	Medlum Danse	11.7		
5		Gray sandy SILT, cemented, moist. (ML)	Dense	13.8		LL=21 PL=18 PI=3
10		Test pit terminated at 8 feet. No groundwater seepage was observed. No caving was observed.				
15						

NOTE: This subsurface information pertains only to this test pit location and should not be interpreted as being indicative of other locations at the site.



Terra Associates, Inc.
 Consultants in Geotechnical Engineering
 Geology and
 Environmental Earth Sciences

LOG OF TEST PIT NO. 4

FIGURE A-5

PROJECT NAME: Puyallup Senior Housing Project PROJ. NO: T-5915-1 LOGGED BY: TA
 LOCATION: Puyallup, Washington SURFACE CONDS: _____ ELEV: 466
 DATE LOGGED: August 3, 2006 DEPTH TO GROUNDWATER: N/A DEPTH TO CAVING: N/A

DEPTH (FT.)	SAMPLE NO.	DESCRIPTION	CONSISTENCY/ RELATIVE DENSITY	W (%)	POCKET PEN. (TSF)	REMARKS
5		(6 inches TOPSOIL) Brown gray silty SAND with oxidation staining, moist. (SM) Very dense below 3 feet.	Dense	18.6		
10		Test pit terminated at 8 feet. No groundwater seepage was observed. No caving was observed.				
15						

NOTE: This subsurface information pertains only to this test pit location and should not be interpreted as being indicative of other locations at the site.



Terra Associates, Inc.
 Consultants In Geotechnical Engineering
 Geology and
 Environmental Earth Sciences

LOG OF TEST PIT NO. 5

FIGURE A-6

PROJECT NAME: Puyallup Senior Housing Project PROJ. NO: T-5915-1 LOGGED BY: TA

LOCATION: Puyallup, Washington SURFACE CONDS: _____ ELEV: 453

DATE LOGGED: August 3, 2006 DEPTH TO GROUNDWATER: N/A DEPTH TO CAVING: N/A

DEPTH (FT.)	SAMPLE NO.	DESCRIPTION	CONSISTENCY/ RELATIVE DENSITY	W (%)	POCKET PEN. (TSF)	REMARKS
5		(9 inches TOPSOIL) Brown gray silty SAND with gravel, cemented, moist. (SM)	Very Dense	11.6 8.3		
10		Test pit terminated at 7 feet. No groundwater seepage was observed. No caving was observed.				
15						

NOTE: This subsurface information pertains only to this test pit location and should not be interpreted as being indicative of other locations at the site.



Terra Associates, Inc.
 Consultants in Geotechnical Engineering
 Geology and
 Environmental Earth Sciences

LOG OF TEST PIT NO. 6

FIGURE A-7

PROJECT NAME: Puyallup Senior Housing Project PROJ. NO: T-5915-1 LOGGED BY: TA

LOCATION: Puyallup, Washington SURFACE CONDS: _____ ELEV: 458

DATE LOGGED: August 3, 2006 DEPTH TO GROUNDWATER: N/A DEPTH TO CAVING: N/A

DEPTH (FT.)	SAMPLE NO.	DESCRIPTION	CONSISTENCY/ RELATIVE DENSITY	W (%)	POCKET PEN. (TSF)	REMARKS
		(9 Inches TOPSOIL)				
		Brown SAND, dry to moist. (SP)	Medium Dense	8.3		
5		Brown sandy GRAVEL to gravelly SAND, moist. (GP-SP)	Dense to Very Dense	3.0 3.2		
10		Test pit terminated at 8 feet. No groundwater seepage was observed. No caving was observed.				
15						

NOTE: This subsurface information pertains only to this test pit location and should not be interpreted as being indicative of other locations at the site.



Terra Associates, Inc.
 Consultants in Geotechnical Engineering
 Geology and
 Environmental Earth Sciences

LOG OF TEST PIT NO. 7

FIGURE A-8

PROJECT NAME: Puyallup Senior Housing Project PROJ. NO: T-5915-1 LOGGED BY: TA

LOCATION: Puyallup, Washington SURFACE CONDS: _____ ELEV: 455

DATE LOGGED: August 3, 2006 DEPTH TO GROUNDWATER: N/A DEPTH TO CAVING: N/A

DEPTH (FT.)	SAMPLE NO.	DESCRIPTION	CONSISTENCY/ RELATIVE DENSITY	W (%)	POCKET PEN. (TSF)	REMARKS
5		(12 inches TOPSOIL) Brown gravelly SAND, dry. (SP)	Dense	5.9		
10		Brown SAND, dry. (SP)	Dense	5.2		
15		Brown gray sandy SILT to SILT with oxidation staining, moist. (ML)	Hard	23.4		
		Test pit terminated at 12 feet. No groundwater seepage was observed. No caving was observed.				

NOTE: This subsurface information pertains only to this test pit location and should not be interpreted as being indicative of other locations at the site.



Terra Associates, Inc.
 Consultants in Geotechnical Engineering
 Geology and
 Environmental Earth Sciences

LOG OF TEST PIT NO. 8

FIGURE A-9

PROJECT NAME: Puyallup Senior Housing Project PROJ. NO: T-6915-1 LOGGED BY: TA

LOCATION: Puyallup, Washington SURFACE CONDS: _____ ELEV: 448

DATE LOGGED: August 3, 2006 DEPTH TO GROUNDWATER: N/A DEPTH TO CAVING: N/A

DEPTH (FT.)	SAMPLE NO.	DESCRIPTION	CONSISTENCY/ RELATIVE DENSITY	W (%)	POCKET PEN. (TSF)	REMARKS
5		(8 inches TOPSOIL) UNCONTROLLED FILL: dark brown black silty sand with decayed wood, trace branches, roots, moist. (SM)	Loose	8.0 18.8		
15		Gray sandy SILT to SILT, moist. (ML)	Medium Stiff	29.5		
20		Test pit terminated at 15 feet. No groundwater seepage was observed. No caving was observed.				

NOTE: This subsurface information pertains only to this test pit location and should not be interpreted as being indicative of other locations at the site.



Terra Associates, Inc.
 Consultants in Geotechnical Engineering
 Geology and
 Environmental Earth Sciences

LOG OF TEST PIT NO. 9

FIGURE A-10

PROJECT NAME: Puyallup Senior Housing Project PROJ. NO: T-5915-1 LOGGED BY: TA

LOCATION: Puyallup, Washington SURFACE CONDS: _____ ELEV: 462

DATE LOGGED: August 3, 2006 DEPTH TO GROUNDWATER: N/A DEPTH TO CAVING: N/A

DEPTH (FT.)	SAMPLE NO.	DESCRIPTION	CONSISTENCY/ RELATIVE DENSITY	W (%)	POCKET PEN. (TSF)	REMARKS
		(9 inches TOPSOIL)				
		Brown silty SAND with gravel, dry. (SM)	Medium Dense	5.9		
5		Brown gravelly SAND, dry. (SP)	Very Dense	3.6		
10		Test pit terminated at 8 feet. No groundwater seepage was observed. No caving was observed.				
15						

NOTE: This subsurface information pertains only to this test pit location and should not be interpreted as being indicative of other locations at the site.



Terra Associates, Inc.
 Consultants in Geotechnical Engineering
 Geology and
 Environmental Earth Sciences

LOG OF TEST PIT NO. 10

FIGURE A-11

PROJECT NAME: Puyallup Senior Housing Project PROJ. NO: T-5915-1 LOGGED BY: TA

LOCATION: Puyallup, Washington SURFACE CONDS: _____ ELEV: 462

DATE LOGGED: August 3, 2006 DEPTH TO GROUNDWATER: N/A DEPTH TO CAVING: N/A

DEPTH (FT.)	SAMPLE NO.	DESCRIPTION	CONSISTENCY/ RELATIVE DENSITY	W (%)	POCKET PEN. (TSF)	REMARKS
5		(9 inches TOPSOIL) Brown silty SAND with gravel, dry to moist. (SM)	Medium Dense	3.6		
10		Test pit terminated at 6 feet. No groundwater seepage was observed. No caving was observed.				
15						

NOTE: This subsurface information pertains only to this test pit location and should not be interpreted as being indicative of other locations at the site.



Terra Associates, Inc.
 Consultants in Geotechnical Engineering
 Geology and
 Environmental Earth Sciences

LOG OF TEST PIT NO. 11

FIGURE A-12

PROJECT NAME: Puyallup Senior Housing Project PROJ. NO: T-5915-1 LOGGED BY: TA

LOCATION: Puyallup, Washington SURFACE CONDS: _____ ELEV: 469

DATE LOGGED: August 3, 2006 DEPTH TO GROUNDWATER: N/A DEPTH TO CAVING: N/A

DEPTH (FT.)	SAMPLE NO.	DESCRIPTION	CONSISTENCY/ RELATIVE DENSITY	W (%)	POCKET PEN. (TSF)	REMARKS
5		(12 inches TOPSOIL) Yellow brown gravelly SAND, dry. (SP)	Very Dense	3.9		
10		Test pit terminated at 6 feet. No groundwater seepage was observed. No caving was observed.				
15						

NOTE: This subsurface information pertains only to this test pit location and should not be interpreted as being indicative of other locations at the site.



Terra Associates, Inc.
 Consultants in Geotechnical Engineering
 Geology and
 Environmental Earth Sciences

LOG OF TEST PIT NO. 12

FIGURE A-13

PROJECT NAME: Puyallup Senior Housing Project PROJ. NO: T-5915-1 LOGGED BY: TA

LOCATION: Puyallup, Washington SURFACE CONDS: _____ ELEV: 472

DATE LOGGED: August 3, 2006 DEPTH TO GROUNDWATER: N/A DEPTH TO CAVING: N/A

DEPTH (FT.)	SAMPLE NO.	DESCRIPTION	CONSISTENCY/ RELATIVE DENSITY	W (%)	POCKET PEN. (TSF)	REMARKS
		(9 inches TOPSOIL)				
		Reddish-brown silty SAND with gravel, dry. (SM)	Medium Dense	8.4		
5		Brown sandy GRAVEL, dry. (GP)	Very Dense	5.8		
10		Test pit terminated at 7 feet. No groundwater seepage was observed. No caving was observed.				
15						

NOTE: This subsurface information pertains only to this test pit location and should not be interpreted as being indicative of other locations at the site.



Terra Associates, Inc.
 Consultants in Geotechnical Engineering
 Geology and
 Environmental Earth Sciences

Date Excavated: 03/27/03

Logged by: EWB

Equipment: Case 580L Backhoe

Surface Elevation (ft): 450

Elevation feet	Depth feet	Sample Number	Water	Graphic Log	Group Symbol	MATERIAL DESCRIPTION	Water Content, %	Dry Unit Weight, lbs/ft ³	OTHER TESTS AND NOTES
450	0				SOD	2- to 6-inch grass and sod			
					SM	Black silty fine to coarse sand, trace organic material (loose, moist)			
		1			SM	Dark brown-black silty sand, trace gravel, occasional wood fragments (loose, moist) (fill)	31		
					SP-SM	Dark brown-black fine to coarse sand with silt and gravel, occasional organic material and cobbles (medium dense, moist) (fill)			
445	5								
		2					31		
					SM	Green/gray silty fine sand with occasional coarse sand, fine gravel, roots (loose, moist) (native)			
435	15	3				Test pit completed at at depth of 15 feet on 03/27/03 Slow groundwater seepage observed at a depth of 5 feet Minor caving observed at depths between 0 and 2 feet			
430	20								

Note: See Figure A-1 for explanation of symbols
The depths of the test pit logs are based on an average of measurements across the test pit and should be considered accurate to 0.5 foot.

LOG OF TEST PIT 11



Project: Puyallup Retail Center
Project Location: Puyallup, Washington
Project Number: 3443-002-00

Figure: A-12
Sheet 1 of 1

3443-002-00 GEI GT 1.0 P:\3443\002\00\TESTPITS.GPJ GEIV2 2.GDT 4/23/03

Date Excavated: 03/27/03

Logged by: EWH

Equipment: Case 580L Backhoe

Surface Elevation (ft): 451

Elevation feet	Depth feet	Sample Number	Water	Graphic Log	Group Symbol	MATERIAL DESCRIPTION	Water Content, %	Dry Unit Weight, lbs/ft ³	OTHER TESTS AND NOTES
0					DUF	6-inch forest duff			
-450					SM	Dark brown silty sand with gravel, trace cobbles (loose, moist) (fill)			
		1			SP	Gray fine to coarse sand with gravel, trace silt (loose, moist) (fill)	4		
-445					ML	Light brown sandy silt (medium stiff, moist) (fill)			
		2			ML	Light brown sandy silt, trace gravel (medium stiff, moist) (fill)	32		
-440					GP	Light brown gravel with sand, trace silt (very dense, moist)			
		3							
-435									
20									

Test pit completed at at depth of 12.5 feet on 03/27/03
 Slow groundwater seepage observed at a depth of 11.75 feet
 Minor caving observed at depths between 0 and 3 feet

Note: See Figure A-1 for explanation of symbols
 The depths of the test pit logs are based on an average of measurements across the test pit and should be considered accurate to 0.5 foot.

LOG OF TEST PIT 12



Project: Puyallup Retail Center
 Project Location: Puyallup, Washington
 Project Number: 3443-002-00

Figure: A-13
 Sheet 1 of 1

3443-002-00 GEI G1PIT_2.1.0_P:\313443002\09\FINALS\344300200TESTPITS.GPJ GEIV2_2.GDT 4/23/03

Date Excavated: 03/27/03

Logged by: EWB

Equipment: Case 580L Backhoe

Surface Elevation (ft): 464

Elevation feet	Depth feet	Sample Number	Water	Graphic Log	Group Symbol	MATERIAL DESCRIPTION	Water Content, %	Dry Unit Weight, lbs/ft ³	OTHER TESTS AND NOTES
0					DUF	6-inch forest duff			
					SM	Brown-reddish brown silty sand with roots (loose, moist)			
					GP-GM	Gray fine to coarse gravel with sand and silt, occasional sand and cobbles (dense, moist)			
460	1	1							
	5								
455	10								
						Test pit completed at at depth of 10.5 feet on 03/27/03 Moderate groundwater seepage observed at a depth of 5.5 feet Moderate caving observed at depths between 1 and 2 feet			
450	15								
445	20								

Note: See Figure A-1 for explanation of symbols
The depths of the test pit logs are based on an average of measurements across the test pit and should be considered accurate to 0.5 foot.

LOG OF TEST PIT 13



Project: Puyallup Retail Center
Project Location: Puyallup, Washington
Project Number: 3443-002-00

Figure: A-14
Sheet 1 of 1

3443-002-00 GEL GT 1.0 P:\3\3443002\00FINAL\344300200TESTPITS.GPJ GEV2 2.GDT 4/23/03

Date Excavated: 03/27/03

Logged by: EWH

Equipment: Case 580L Backhoe

Surface Elevation (ft): 460

Elevation feet	Depth feet	Sample Number	Water	Graphic Log	Group Symbol	MATERIAL DESCRIPTION	Water Content, %	Dry Unit Weight, lbs/ft ³	OTHER TESTS AND NOTES
460	0				DUF	3- to 6-inch forest duff			
					SM	Brown silty sand with gravel (loose, moist)			
		1			GP	Gray fine to coarse gravel with sand, trace silt (dense, wet)			
455	5								
450	10					Test pit completed at at depth of 10 feet on 03/27/03 Rapid groundwater seepage observed at a depth of 5 feet Slight caving observed at depths between 1 and 3 feet			
445	15								
440	20								

Note: See Figure A-1 for explanation of symbols
The depths of the test pit logs are based on an average of measurements across the test pit and should be considered accurate to 0.5 foot.

LOG OF TEST PIT 14



Project: Puyallup Retail Center
Project Location: Puyallup, Washington
Project Number: 3443-002-00

Figure: A-15
Sheet 1 of 1

3443-002-00 GEI G11-SPIT 2.1.0 P:\313443002\00\FINAL\3443002007TESTPITS.GPJ GEIV2, 2.GDI 4/23/03

Date Excavated: 03/27/03

Logged by: EWB

Equipment: Case 580L Backhoe

Surface Elevation (ft): 467

Elevation feet	Depth feet	Sample Number	Water	Graphic Log	Group Symbol	MATERIAL DESCRIPTION	Water Content, %	Dry Unit Weight, lbs/ft ³	OTHER TESTS AND NOTES
0					SOD	6-inch grass and sod			
					SM	Brown silty sand with gravel, trace roots (loose, moist)			
465		1			GP	Gray fine to coarse gravel with sand, trace silt (medium dense, moist)			
5									
460									
10									
455						Test pit completed at at depth of 10 feet on 03/27/03 Minor groundwater seepage observed at a depth of 6 feet Severe caving observed at depths between 2 and 10 feet			
15									
450									
20									

Note: See Figure A-1 for explanation of symbols
The depths of the test pit logs are based on an average of measurements across the test pit and should be considered accurate to 0.5 foot.

LOG OF TEST PIT 15



Project: Puyallup Retail Center
Project Location: Puyallup, Washington
Project Number: 3443-002-00

Figure: A-16
Sheet 1 of 1

3443-002-00 GEL.GT.15.PIT.2.1.0 P:\3134\3002\00FINAL\3443002\00TESTPITS.GPJ GENV2.2.GDT 4/23/03

Date Excavated: 03/31/03

Logged by: KWG

Equipment: Case 580L Backhoe

Surface Elevation (ft): 468

Elevation feet	Depth feet	Sample Number	Water	Graphic Log	Group Symbol	MATERIAL DESCRIPTION	Water Content, %	Dry Unit Weight, lbs/ft ³	OTHER TESTS AND NOTES
0					DUF	2- to 4-inch forest duff			
		1			SP-SM	Reddish brown fine sand with silt, occasional gravel (medium dense, moist)			
		2			GP	Gray fine to coarse gravel with sand, trace silt (dense, moist)			
465					SP	Gray fine to medium sand, trace silt and granite cobbles (dense, moist)			
		3							
5									
		4			SM	Gray silty fine sand (very dense, moist)			
460									
						Test pit completed at at depth of 8 feet on 03/31/03 No groundwater seepage observed No caving observed			
10									
455									
15									
450									
20									

Note: See Figure A-1 for explanation of symbols
The depths of the test pit logs are based on an average of measurements across the test pit and should be considered accurate to 0.5 foot.

LOG OF TEST PIT 24



Project: Puyallup Retail Center
Project Location: Puyallup, Washington
Project Number: 3443-002-00

Figure: A-25
Sheet 1 of 1

PIT_2.1.0_P\3394\3302\00\FINAL\344300200TESTPITS.GPJ GEI\2.GDT 4/23/03

3443-002-00 GEI

Date Excavated: 03/31/03

Logged by: K.W.G

Equipment: Case 580L Backhoe

Surface Elevation (ft): 462

Elevation feet	Depth feet	Sample Number	Water	Graphic Log	Group Symbol	MATERIAL DESCRIPTION	Water Content, %	Dry Unit Weight, lbs/ft ³	OTHER TESTS AND NOTES
0					DUP	2- to 4-inch forest duff			
					SM	Reddish brown silty fine to medium sand, trace gravel (medium dense, moist)			
460		1	▼		SM	Reddish gray silty fine sand (dense, wet)	22		%F = 15.7 Sieve Analysis
					GP	Gray fine to coarse gravel with sand, trace silt (dense, wet)			
455		2							
						Test pit completed at at depth of 8 feet on 03/31/03 Rapid groundwater seepage observed at a depth of 2 feet Minor caving observed at depths between 2 and 4 feet			
450									
445									
20									

Note: See Figure A-1 for explanation of symbols

The depths of the test pit logs are based on an average of measurements across the test pit and should be considered accurate to 0.5 foot.

.TPIT_2.1.0 P:\3443002\03\FINAL\344300200TESTPITS.GPJ GEIV2_2.GDT 4/23/03

3443-002-00 GEI

LOG OF TEST PIT 26



Project: Puyallup Retail Center
 Project Location: Puyallup, Washington
 Project Number: 3443-002-00

Figure: A-27
 Sheet 1 of 1



TERRA ASSOCIATES, Inc.

Consultants in Geotechnical Engineering, Geology
and
Environmental Earth Sciences

May 22, 2023
Project No. T-5915-3

Mr. Stephen Nornes
Presbyterian Homes & Services and Senior Housing Partners
2823 Hamline Avenue North
Roseville, Minnesota 55113

Subject: Response to Comments
Geotechnical Report Addendum
Wesley Homes Expansion
Puyallup, Washington

Reference: Geotechnical Report Addendum, Wesley Homes Expansion, Puyallup, Washington, Project No. T-5915-3, prepared by Terra Associates, Inc., dated December 29, 2022

Dear Mr. Nornes:

Subsequent submittal of the referenced addendum, the City of Puyallup has requested additional information regarding the Landslide Hazard Area. Specifically, the city has requested Puyallup Municipal Code (PMC) 21.06.1230 (2) (A-F) and .1230 (11) be addressed in detail. In addition, the city has requested we address pier design foundations in more detail and the presence of seeps on the site. The following summarizes our review and response to these comments.

PMC 21.06.1230 (2) (a)

This section of the PMC requires that the proposed development in a landslide hazard area not decrease the factor of safety for landslide occurrences below 1.5 for static conditions and 1.2 for dynamic (seismic) conditions. To address this comment, we completed a stability analysis of a representative cross section of the slope that included grading and application of building loading from the proposed development. We also completed additional subsurface exploration to better define the limits of the unsuitable existing fill soils and underlying competent native soils. Supplemental test pit locations and test pit logs are attached as Figures 1 through 9. The location of the cross section analyzed is also shown on Figure 1.

We completed the stability analysis using the SLIDE2 computer program published by RocScience. Results of the analysis indicate that with the exiting unsuitable fill soils removed and replaced with structural fill placed and compacted in accordance with recommendations in our geotechnical report, the minimum safety factor under static conditions of 1.5 or greater would be met. A graphic of the cross section showing these results along with soil parameters used in the analysis is attached as Figure 10.

Mr. Stephen Nornes
May 22, 2023

Seismic (Pseudostatic) analysis was then completed along this section. The acceleration input into the analysis was the Peak Ground Acceleration (PGA) for the maximum considered event (MCE) as defined by the current International Building Code (IBC). This value represents an earthquake with a 2 percent chance of exceedance in 50 years (1 in 2500 years). This acceleration was adjusted for sloping conditions. The results of this analysis indicate safety factors less than the required 1.2 minimum would be present. These results are shown on attached Figure 11.

We would note that pseudostatic safety factors of less than 1 (one) do not necessarily reflect that a slope failure or a landslide would occur. The ground shaking may cause the slope to displace downgradient, but the amount of displacement may not be significant or sufficient to cause damage to the facility that would be considered a life safety issue. To evaluate this condition, we completed additional dynamic analysis of the slope section to evaluate potential lateral downslope displacements (Newmark Analysis). The earthquake record used in this analysis was a Cape Mendocino event that had a PGA of .59 which is similar to this sites PGA. This analysis indicates that the maximum displacement along the western side of the building would be less than two-inches with displacements diminishing to less than one-half-inch towards the mid-point of the structure. This amount of movement would not be categorized as a slope failure or landslide. Damage to the building would occur, however, this amount of lateral movement would cause damage of a cosmetic nature and would not be a life safety issue that would require design which would mitigate the displacement, in our opinion. Results of this analysis are shown on attached Figure 12.

In our opinion, provided the owner is willing to accept the risk of building damage caused by minimal downslope displacement following a design level earthquake, no design measures need to be implemented to mitigate this movement. However, if the owner is not willing to accept this risk, then the western half of the building paralleling the crest of the slope should be supported on pile foundations.

PMC 21.06.1230 (2) (b)

The proposed development will actually decrease the potential for slope movements, particularly during a seismic event, than what currently exists.

PMC 21.06.1230 (2) (c)

The proposed development will reduce surface water discharge on the slope by collecting rainfall runoff in the stormwater system and discharging it to an approved controlled location.

PMC 21.06.1230 (2) (d)

The structure's location does not alter the slope's existing gradient. As shown on the structural drawings, spread footings parallel to the slope crest will be deepened to provide a minimum horizontal distance of one half the slope height (ten feet) from the edge of footing to the slope face in accordance with the IBC.

PMC 21.06.1230 (2) (e)

A short height engineered retaining wall will be used along the crest of the slope to create an access path on the west side of the building. The height of this wall is less than seven-feet.

PMC 21.06.1230 (2) (f)

As noted in response to PMC 21.06.1230 (2) (c), the development will improve drainage conditions on the slope by collecting rainfall runoff and directing it to a controlled approved point of discharge. This will reduce the landslide and erosion hazards that currently exist.

PMC 21.06.1230 (11)

For monitoring we would recommend adding the following note to the project drawings:

- During site grading and building construction the geotechnical engineer of record or his/her representative will perform bi-weekly reconnaissance of the slope and issue a field report regarding site conditions. These bi-weekly slope recons will continue until building shell construction and stormwater facilities are completed and functional. Post building construction slope recons shall occur on a quarterly basis for a period of no less than two years. If no instability or erosion issues are present at that time, monitoring can be terminated.

Rammed Aggregate Piers (RAP's)

RAPs are densely compact columns of aggregate, either processed crushed or non-crushed gravel, that are installed below the building foundations. Construction machinery used to construct the piers is similar to that used to construct drilled shaft piles or piers. The piers are not installed as structural elements but rather are a form of excavation and refilling with compacted structural fill. The number of piers required and spacing is calculated using a replacement ratio where the overall engineering characteristics of the fill is improved to the soil parameters required, to provide for suitable foundation support and/or site slope stability. If used, they are typically designed and constructed by a geotechnical specialty contractor.

Site Seepage



The site seepage mentioned in the referenced addendum took place on the east and south sides of the existing Lodge building. Flat grades along these sides of the building along with relatively low permeable fill soils resulted in ponding water areas that eventually seeped into the Lodge lower-level garage. Photographs documenting conditions observed in April 2019 are attached for reference.

This condition clearly demonstrates that infiltration of stormwater using low impact development elements such as permeable pavement would not be feasible at the site. To further demonstrate this, in addition to excavating the supplemental test pits, we performed a small-scale pilot infiltration test (PIT) in the proposed pavement area south of the new building. This PIT location is shown on Figure 1. Approximately 50 gallons of water was introduced into the test pit at a depth 2.5 feet. This resulted in a head of about six inches. After two hours, no reduction in the head occurred demonstrating the fill soils do not infiltrate. The log for the PIT along with testing comments is included with the test pit logs.

Mr. Stephen Nornes
May 22, 2023

We trust the information presented is sufficient for your current needs. If you have any questions or require additional information, please call.

Sincerely yours,
TERRA ASSOCIATES, INC.



Theodore J. Schepper, P.E. 5-22-2023
Senior Principal Engineer

Cc: Ms. Jill Krance, In Site Architects
Mr. Dan Balmelli, P.E., Barghausen Consulting Engineers

Attachments: Figure 1 – Exploration Location Plan
Figures 2 through 9 – Test Pit Logs
Figures 10 through 12 – SLIDE2 Stability Analysis Results
Site Photos

LOG OF TEST PIT NO. 201

FIGURE 2

PROJECT NAME: Wesley Homes Puyallup PROJ. NO: T-5915-3 LOGGED BY: JCS

LOCATION: Puyallup, Washington SURFACE CONDITIONS: Grass, Brush APPROX. ELEV: ~452

DATE LOGGED: January 31, 2023 DEPTH TO GROUNDWATER: NA DEPTH TO CAVING: NA

Depth (ft)	Sample No.	Description	Consistency/ Relative Density	W (%)
0		Fill: Brown silty SAND with gravel, fine sand, fine to coarse gravel, moist, scattered cobbles, trace of geosynthetic fabric fragments. (SM)	Medium Dense	
1				
2		Fill: Brown silty SAND with gravel, fine to medium sand, fine to coarse gravel, moist to wet, scattered cobbles, numerous organic silty sand pockets and layers, scattered wood debris. (SM) (Strippings)		
3				
4				
5				
6				
7		- Numerous wood debris below about 7 feet.		
8				
9				
10				
11				
12	1	Gray-brown silty SAND to SAND with silt, fine grained, trace of fine gravel, moist, scattered mottling, trace of black organic fragments. (SM/SP-SM)	Medium Dense to Dense	21.6
13				
14		Gray silty SAND with gravel, fine to medium sand, fine to coarse gravel, moist to wet, trace of cobbles. (SM)		
15		Test pit terminated at 14.5 feet. No groundwater seepage.		
16				
17				
18				

NOTE: This subsurface information pertains only to this test pit location and should not be interpreted as being indicative of other locations at the site.

Terra Associates, Inc.

Consultants in Geotechnical Engineering
Geology and

LOG OF TEST PIT NO. 202

FIGURE 3

PROJECT NAME: Wesley Homes Puyallup PROJ. NO: T-5915-3 LOGGED BY: JCS

LOCATION: Puyallup, Washington SURFACE CONDITIONS: Grass, Brush APPROX. ELEV: ~455

DATE LOGGED: January 31, 2023 DEPTH TO GROUNDWATER: NA DEPTH TO CAVING: NA

Depth (ft)	Sample No.	Description	Consistency/ Relative Density	W (%)
0				
1		Fill: Brown silty SAND with gravel, fine sand, fine to coarse gravel, moist, scattered cobbles, trace of geosynthetic fabric fragments. (SM)		
2		Fill: Brown silty SAND with gravel, fine to medium sand, fine to coarse gravel, moist to wet, scattered cobbles, trace of 1.5- to 2-foot diameter boulders, numerous organic silty sand pockets and layers, numerous wood debris. (SM) (Strippings)	Medium Dense	
3				
4				
5				
6				
7				
8				
9				
10				
11				
12				
13		Gray-brown silty SAND to SAND with silt, fine grained, trace of fine to coarse gravel, wet, scattered mottling, trace of black organic fragments. (SM/SP-SM)		
14		Test pit terminated at 13 feet. No groundwater seepage.		
15				
16				
17				
18				

NOTE: This subsurface information pertains only to this test pit location and should not be interpreted as being indicative of other locations at the site.

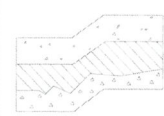

LOG OF TEST PIT NO. 203

FIGURE 4

PROJECT NAME: Wesley Homes Puyallup **PROJ. NO:** T-5915-3 **LOGGED BY:** JCS

LOCATION: Puyallup, Washington **SURFACE CONDITIONS:** Grass, Brush **APPROX. ELEV:** ~459

DATE LOGGED: January 31, 2023 **DEPTH TO GROUNDWATER:** NA **DEPTH TO CAVING:** NA

Depth (ft)	Sample No.	Description	Consistency/ Relative Density	W (%)
0		Fill: Brown silty GRAVEL with sand, fine to coarse gravel, fine to coarse sand, wet. (GM)	Dense	
1		Fill: Brown silty SAND with gravel, fine sand, fine to coarse gravel, moist, trace of cobbles. (SM)		
2				
3		Fill: Gray-brown silty SAND with gravel, fine to medium sand, fine to coarse gravel, moist, scattered cobbles, numerous dark brown organic silty sand pockets and layers, scattered to numerous wood debris. (SM) (Strippings)	Medium Dense	
4				
5				
6				
7				
8				
9				
10				
11				
12				
13		Gray-brown SILT with sand to silty SAND, fine sand, scattered fine to coarse gravel, wet (grading moist with depth). (ML/SM)	Medium Dense to Dense	24.3
14	1			
15		Test pit terminated at 16 feet. No groundwater seepage.		
16				
17				
18				

NOTE: This subsurface information pertains only to this test pit location and should not be interpreted as being indicative of other locations at the site.

LOG OF TEST PIT NO. 204

FIGURE 5

PROJECT NAME: Wesley Homes Puyallup **PROJ. NO:** T-5915-3 **LOGGED BY:** JCS

LOCATION: Puyallup, Washington **SURFACE CONDITIONS:** Grass, Brush **APPROX. ELEV:** ~464

DATE LOGGED: January 31, 2023 **DEPTH TO GROUNDWATER:** NA **DEPTH TO CAVING:** NA

Depth (ft)	Sample No.	Description	Consistency/ Relative Density	W (%)
0				
1		Fill: Brown silty GRAVEL with sand, fine to coarse gravel, fine to coarse sand, moist to wet. (GM)	Dense	
2				
3		Fill: Gray to brown silty GRAVEL with sand, fine to coarse gravel, fine to medium sand, moist to wet, scattered cobbles, trace of 1-foot diameter boulders. (GM)	Medium Dense	
4				
5		Fill: Brown silty SAND with gravel, fine sand, fine to coarse gravel, moist, scattered cobbles, scattered dark brown organic silty sand pockets and layers, scattered to numerous wood debris. (SM) (Strippings)		
6				
7			Medium Dense	
8				
9				
10			Medium Dense	
11				
12			Medium Dense	
13				
14		Gray-brown silty SAND, fine grained, moist to wet. (SM)	Medium Dense	
15				
16		Test pit terminated at 15 feet. No groundwater seepage.		
17				
18				

NOTE: This subsurface information pertains only to this test pit location and should not be interpreted as being indicative of other locations at the site.



Terra
Associates, Inc.

Consultants in Geotechnical Engineering
Geology and

LOG OF TEST PIT NO. 205

FIGURE 6

PROJECT NAME: Wesley Homes Puyallup PROJ. NO: T-5915-3 LOGGED BY: JCS

LOCATION: Puyallup, Washington SURFACE CONDITIONS: Grass, Brush APPROX. ELEV: ~458

DATE LOGGED: January 31, 2023 DEPTH TO GROUNDWATER: NA DEPTH TO CAVING: NA

Depth (ft)	Sample No.	Description	Consistency/ Relative Density	W (%)
0		Fill: Brown silty SAND with gravel, fine sand, fine to coarse gravel, moist. (SM)	Medium Dense	
1				
2		Fill: Brown silty SAND with gravel, fine to medium sand, fine to coarse gravel, moist to wet, scattered cobbles, scattered dark brown organic silty sand pockets and layers, scattered to numerous wood debris. (SM) (Strippings)		
3				
4				
5				
6				
7				
8				
9				
10				
11				
12				
13		Gray silty SAND, fine grained, trace of fine to coarse gravel, moist to wet, scattered faint mottling. (SM)		
14		Test pit terminated at 14 feet. No groundwater seepage.		
15				
16				
17				
18				

NOTE: This subsurface information pertains only to this test pit location and should not be interpreted as being indicative of other locations at the site.

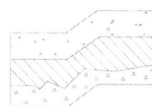

Terra Associates, Inc.
 Consultants in Geotechnical Engineering
 Geology and

LOG OF TEST PIT NO. 206

FIGURE 7

PROJECT NAME: Wesley Homes Puyallup **PROJ. NO:** T-5915-3 **LOGGED BY:** JCS

LOCATION: Puyallup, Washington **SURFACE CONDITIONS:** Sparse grass **APPROX. ELEV:** ~465

DATE LOGGED: January 31, 2023 **DEPTH TO GROUNDWATER:** NA **DEPTH TO CAVING:** NA

Depth (ft)	Sample No.	Description	Consistency/ Relative Density	W (%)
0				
1		Fill: Gray-brown silty GRAVEL with sand, fine to coarse gravel, fine to coarse sand, wet. (GM)	Dense	
2				
3				
4		Fill: Brown silty SAND with gravel, fine sand, fine to coarse gravel, moist, scattered cobbles, scattered dark brown organic silty sand pockets and layers, trace of wood debris. (SM) (Strippings)	Medium Dense	
5				
6				
7				
8				
9				
10				
11	1	Gray-brown silty SAND to SAND with silt, fine grained, moist, scattered mottling. (SM/SP-SM)		17.1
12		Test pit terminated at 12 feet. No groundwater seepage.		
13				
14				
15				
16				
17				
18				

NOTE: This subsurface information pertains only to this test pit location and should not be interpreted as being indicative of other locations at the site.

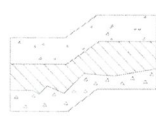

LOG OF TEST PIT NO. 207

FIGURE 8

PROJECT NAME: Wesley Homes Puyallup **PROJ. NO:** T-5915-3 **LOGGED BY:** JCS

LOCATION: Puyallup, Washington **SURFACE CONDITIONS:** Sparse grass **APPROX. ELEV:** ~464

DATE LOGGED: January 31, 2023 **DEPTH TO GROUNDWATER:** 1.5-2 ft **DEPTH TO CAVING:** NA

Depth (ft)	Sample No.	Description	Consistency/ Relative Density	W (%)
0				
1		Fill: Gray-brown silty GRAVEL with sand, fine to coarse gravel, fine to coarse sand, wet, numerous cobbles. (GM)	Dense	
2		Fill Gray-brown silty SAND with gravel, fine to medium sand, fine to coarse gravel, moist to wet. (SM)	Medium Dense	
3				
4				
5		Fill: Gray to gray-brown silty SAND with gravel, fine to coarse sand, fine to coarse gravel, moist to wet, scattered cobbles, trace of wood debris. (SM)	Dense	
6				
7				
8				
9	1	Brown silty GRAVEL with sand, fine to coarse gravel, fine to coarse sand, moist to wet. (GM)	Medium Dense to Dense	9.1
10	2	Brown SAND with silt, fine to medium grained, trace of fine gravel, moist. (SP-SM)	Medium Dense	25.1
11				
12	3	Gray-brown SILT with fine sand, moist, mottled. (ML)	Medium Dense to Dense	32.2
13				
14		Test pit terminated at 14 feet.		
15		Light groundwater seepage between 1.5 and 2 feet.		
16				
17				
18				

NOTE: This subsurface information pertains only to this test pit location and should not be interpreted as being indicative of other locations at the site.

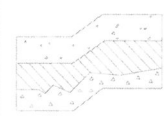

LOG OF PILOT INFILTRATION TEST NO. 1

FIGURE 9

PROJECT NAME: Wesley Homes Puyallup PROJ. NO: T-5915-3 LOGGED BY: JCS

LOCATION: Puyallup, Washington SURFACE CONDITIONS: Sparse grass APPROX. ELEV: ~464

DATE LOGGED: January 31, 2023 DEPTH TO GROUNDWATER: NA DEPTH TO CAVING: NA

Depth (ft)	Sample No.	Description	Consistency/ Relative Density	W (%)
0		Fill: Brown silty SAND with gravel, fine to medium sand, fine to coarse gravel, moist to wet, scattered rounded to angular cobbles. (SM)		
1				
2		- Infiltration test surface at approximately 2.5 feet.		
3		Small-Scale Test: PIT Dimensions approximately 3 feet x 4 feet. Test Depth approximately 2.5 feet.	Dense	
4		- Ran approximately 48 gallons into pit at approximately 3.5 gallons per minute. - Started flow at approximately 8:00 AM. - Stopped flow when water depth reached 0.5 feet at 8:11 AM. - Observed water level from 8:11 AM to 10:00 AM. - No change in water level. - Not infiltrating.		
5		Test pit terminated at 5 feet. No groundwater seepage. Small-scale pilot infiltration test performed at approximately 2.5 feet.		
6				

NOTE: This subsurface information pertains only to this test pit location and should not be interpreted as being indicative of other locations at the site.



Terra Associates, Inc.
 Consultants in Geotechnical Engineering
 Geology and

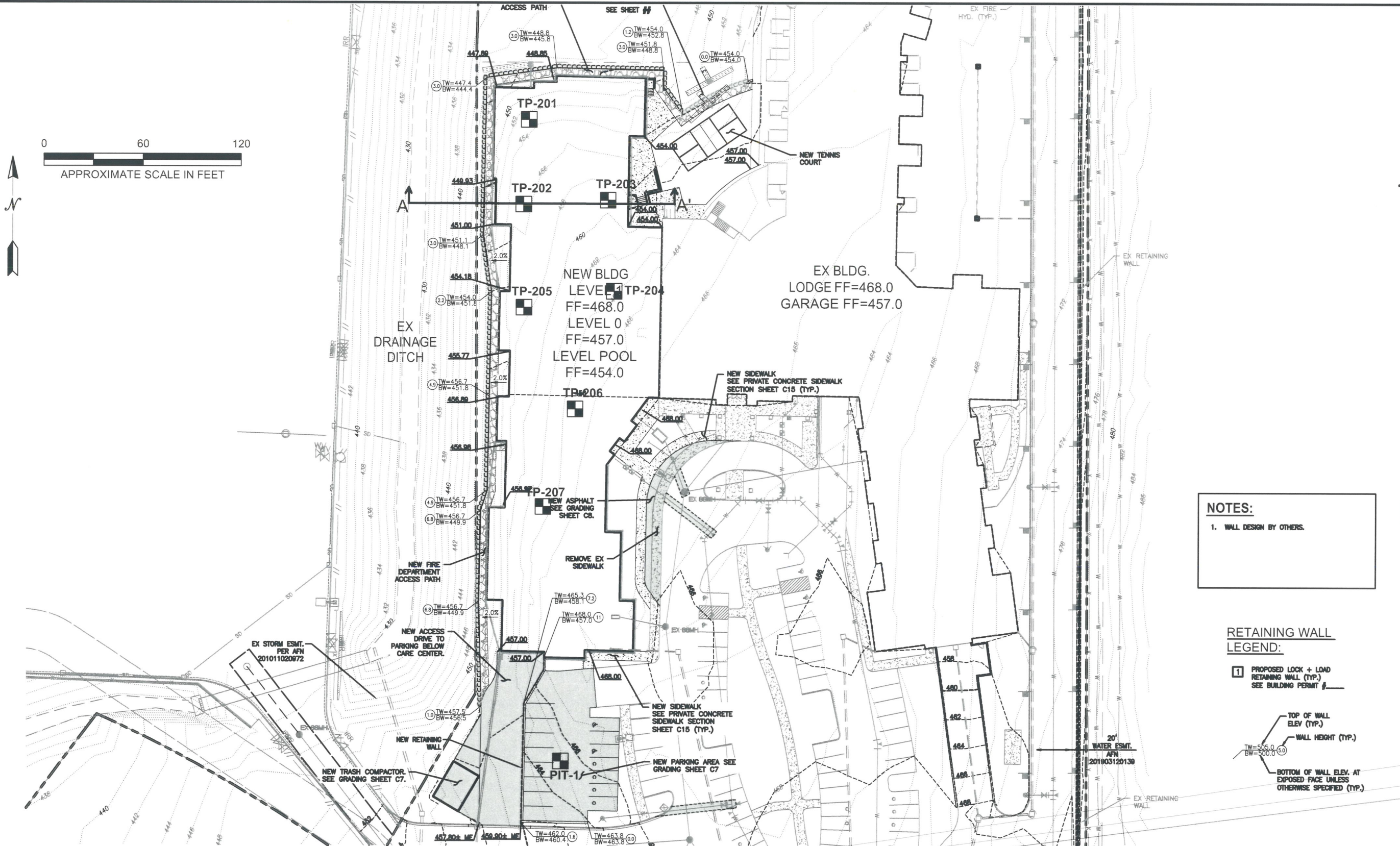

NOTES:
1. WALL DESIGN BY OTHERS.

RETAINING WALL LEGEND:
 1 PROPOSED LOCK + LOAD RETAINING WALL (TYP.) SEE BUILDING PERMIT #
 TOP OF WALL ELEV. (TYP.)
 WALL HEIGHT (TYP.)
 BOTTOM OF WALL ELEV. AT EXPOSED FACE UNLESS OTHERWISE SPECIFIED (TYP.)

NOTE:
THIS SITE PLAN IS SCHEMATIC. ALL LOCATIONS AND DIMENSIONS ARE APPROXIMATE. IT IS INTENDED FOR REFERENCE ONLY AND SHOULD NOT BE USED FOR DESIGN OR CONSTRUCTION PURPOSES.



REFERENCE:
SITE PLAN PROVIDED BY BARGHAUSEN CONSULTING ENGINEERS

LEGEND:
 APPROXIMATE TEST PIT LOCATION

Terra Associates, Inc.
 Consultants in Geotechnical Engineering
 Geology and Environmental Earth Sciences

**EXPLORATION LOCATION PLAN
 WESLEY BRADLEY PARK PHASE 2
 PUYALLUP, WASHINGTON**

Proj. No. T-5915-3 Date MAY 2023 Figure 1

Material Name	Color	Unit Weight (lbs/ft3)	Strength Type	Cohesion (psf)	Phi (deg)	Water Surface	Hu Type	Hu
New Structural Fill		125	Mohr-Coulomb	50	36	Water Surface	Custom	1
Existing Fill		115	Mohr-Coulomb	50	26	Water Surface	Custom	1
Native Silty Sand/Sandy Silt		120	Mohr-Coulomb	100	34	Water Surface	Custom	1

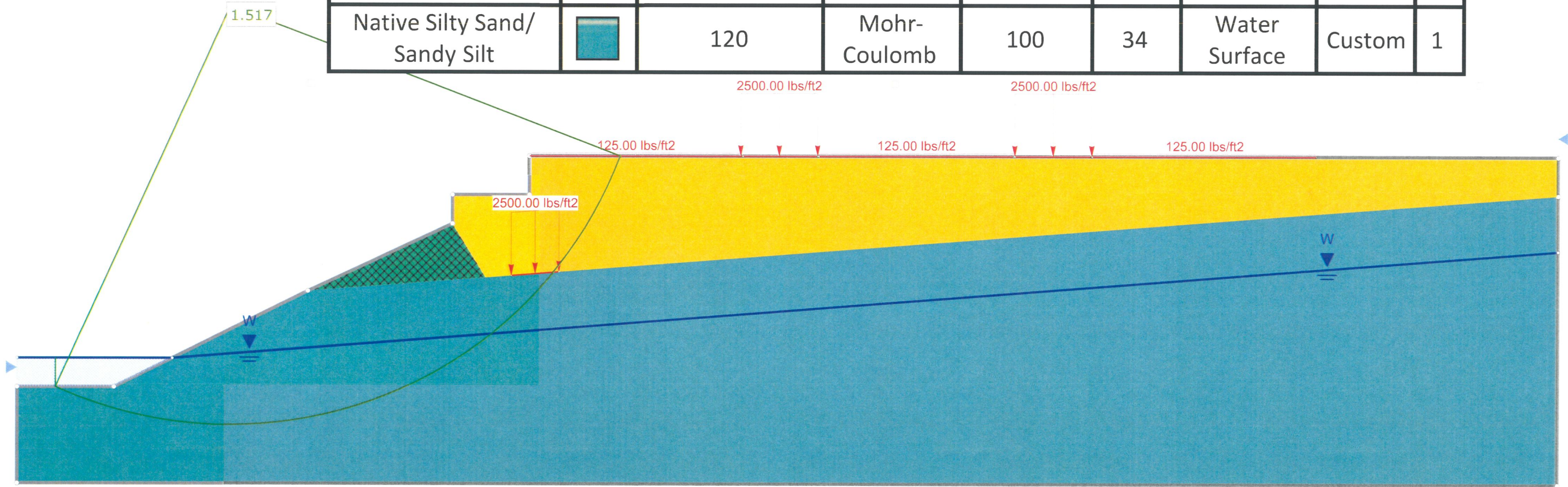

Figure 10

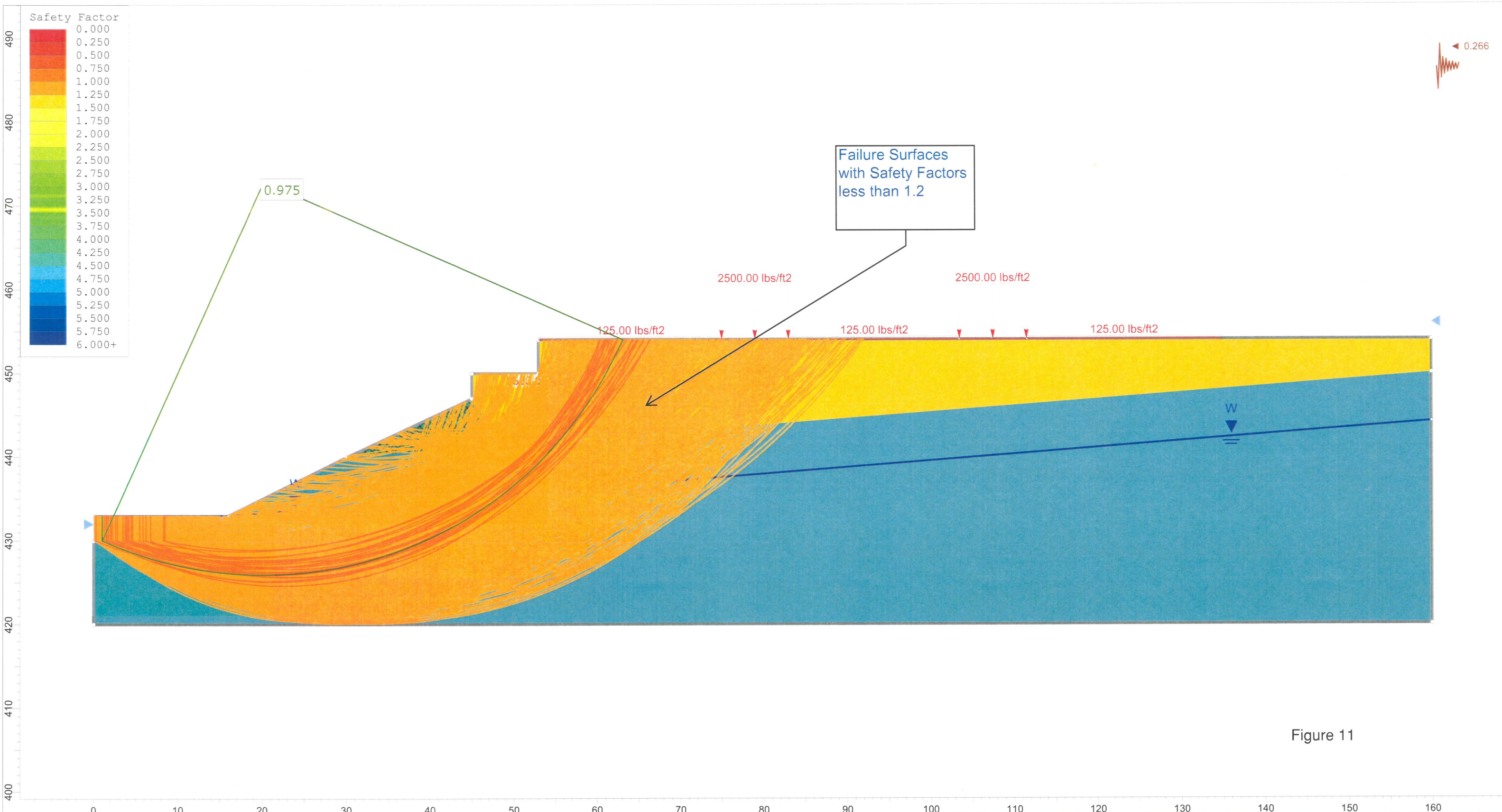

Figure 11

SLIDEINTERPRET 9.008

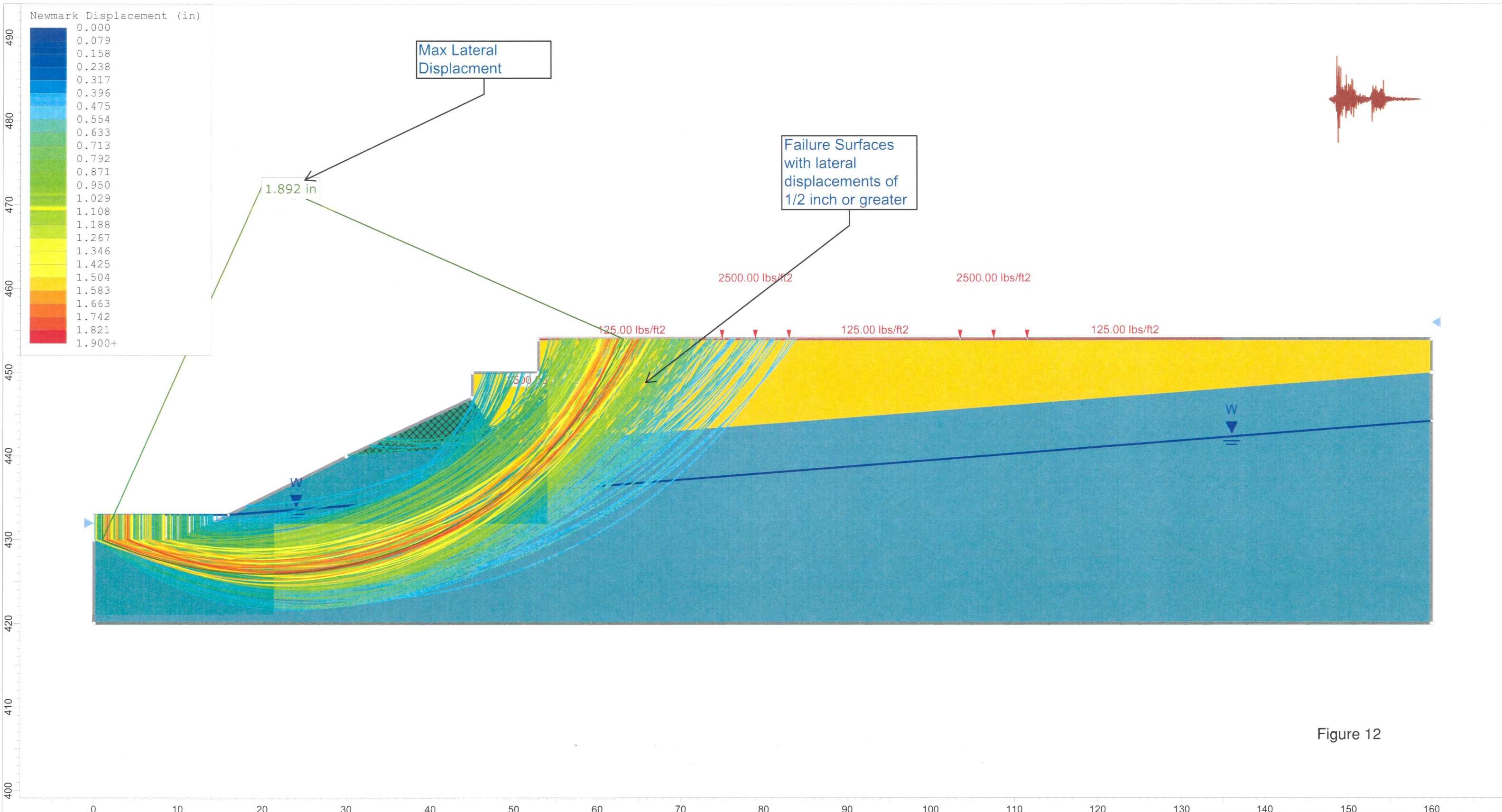

Figure 12

SLIDEINTERPRET 9.008

APPENDIX A
CONSTRUCTION STORMWATER POLLUTION
PREVENTION PLAN

Stormwater Pollution Prevention Plan

For
Wesley Homes Puyallup

Prepared For
Wesley Homes
815 South 216th Street
Des Moines, WA 98190

Owner	Developer	Operator/Contractor
Wesley Homes 815 South 16th Street Des Moines, WA 98190	Wesley Homes 815 South 216th Street Des Moines, WA 98190	TBD

Project Site Location
707 39th Avenue SE
Puyallup, WA 98374

Certified Erosion and Sediment Control Lead
TBD

SWPPP Prepared By
Barghausen Consulting Engineers, Inc.
18215 - 72nd Avenue South
Kent, WA 98032
(425) 251-6222
Cara Visintainer, PE

SWPPP Preparation Date
July 6, 2023

Approximate Phase 2 Project Construction Dates
August 2023 – August 2024

Contents

1.0	Introduction.....	1
2.0	Site Description	3
2.1	Existing Conditions	3
2.2	Proposed Construction Activities	3
3.0	Construction Stormwater BMPs.....	5
3.1	The 14 BMP Elements.....	5
3.1.1	Element #1 – Mark Clearing Limits	5
3.1.2	Element #2 – Establish Construction Access.....	5
3.1.3	Element #3 – Control Flow Rates	6
3.1.4	Element #4 – Install Sediment Controls	6
3.1.5	Element #5 – Stabilize Soils.....	8
3.1.6	Element #6 – Protect Slopes.....	8
3.1.7	Element #7 – Protect Drain Inlets	9
3.1.8	Element #8 – Stabilize Channels and Outlets	9
3.1.9	Element #9 – Control Pollutants.....	10
3.1.10	Element #10 – Control Dewatering	11
3.1.11	Element #11 – Maintain BMPs.....	12
3.1.12	Element #12 – Manage the Project.....	12
3.1.13	Element #13 – Construction Stormwater Chemical Treatment.....	14
3.1.14	Element #14 – Construction Stormwater Filtration	20
3.2	Site Specific BMPs	21
4.0	Construction Phasing and BMP Implementation	22
5.0	Pollution Prevention Team	23
5.1	Roles and Responsibilities.....	23
5.2	Team Members.....	24
6.0	Site Inspections and Monitoring.....	25
6.1	Site Inspection	25
6.1.1	Site Inspection Frequency.....	25
6.1.2	Site Inspection Documentation	25
6.2	Stormwater Quality Monitoring.....	26
6.2.1	Turbidity Sampling	26
6.2.2	pH Sampling	27
7.0	Reporting and Recordkeeping	28
7.1	Recordkeeping.....	28
7.1.1	Site Log Book.....	28
7.1.2	Records Retention	28
7.1.3	Access to Plans and Records	28
7.1.4	Updating the SWPPP.....	28
7.2	Reporting	29
7.2.1	Discharge Monitoring Reports.....	29
7.2.2	Notification of Noncompliance.....	29

- Appendix A Site Plans**
- Appendix B Construction BMPs**
- Appendix C Alternative BMPs**
- Appendix D General Permit**
- Appendix E Site Inspection Forms (and Site Log)**
- Appendix F Engineering Calculations**

1.0 Introduction

This Stormwater Pollution Prevention Plan (SWPPP) has been prepared as part of the NPDES stormwater permit requirements for the Wesley Homes project Puyallup, Washington. The proposed site is at 707 39th Avenue SE Puyallup, Washington.

Construction activities will include critical area protection, site preparation, the addition of two new buildings, asphalt parking and roadways, concrete walkways, landscaping, utility work including power, telephone, gas, cable television, water, sewer, and storm appurtenances.

The purpose of this SWPPP is to describe the proposed construction activities and all temporary and permanent erosion and sediment control (TESC) measures, pollution prevention measures, inspection/monitoring activities, and recordkeeping that will be implemented during the proposed construction project. The objectives of the SWPPP are to:

- 1. Implement Best Management Practices (BMPs) to prevent erosion and sedimentation, and to identify, reduce, eliminate or prevent stormwater contamination and water pollution from construction activity.**
- 2. Prevent violations of surface water quality, ground water quality, or sediment management standards.**
- 3. Prevent, during the construction phase, adverse water quality impacts including impacts on beneficial uses of the receiving water by controlling peak flow rates and volumes of stormwater runoff at the Permittee's outfalls and downstream of the outfalls.**

This SWPPP was prepared using the Ecology SWPPP Template downloaded from the Ecology website. This SWPPP was prepared based on the requirements set forth in the Construction Stormwater General Permit, *Stormwater Management Manual for Western Washington*. The report is divided into seven main sections with several appendices that include stormwater related reference materials. The topics presented in the each of the main sections are:

- **Section 1 – INTRODUCTION.** This section provides a summary description of the project, and the organization of the SWPPP document.
- **Section 2 – SITE DESCRIPTION.** This section provides a detailed description of the existing site conditions, proposed construction activities, and calculated stormwater flow rates for existing conditions and post-construction conditions.
- **Section 3 – CONSTRUCTION BMPs.** This section provides a detailed description of the BMPs to be implemented based on the 14 required elements of the SWPPP.

- Section 4 – CONSTRUCTION PHASING AND BMP IMPLEMENTATION. This section provides a description of the timing of the BMP implementation in relation to the project schedule.
- Section 5 – POLLUTION PREVENTION TEAM. This section identifies the appropriate contact names (emergency and non-emergency), monitoring personnel, and the onsite temporary erosion and sedimentation control inspector
- Section 6 – INSPECTION AND MONITORING. This section provides a description of the inspection and monitoring requirements such as the parameters of concern to be monitored, sample locations, sample frequencies, and sampling methods for all stormwater discharge locations from the site.
- Section 7 – RECORDKEEPING. This section describes the requirements for documentation of the BMP implementation, site inspections, monitoring results, and changes to the implementation of certain BMPs due to site factors experienced during construction.

Supporting documentation and standard forms are provided in the following Appendices:

Appendix A – Site Plans
Appendix B – Construction BMPs
Appendix C – Alternative BMPs
Appendix D – General Permit
Appendix E – Site Inspection Forms (and Site Log)
Appendix F – Engineering Calculations

2.0 Site Description

2.1 Existing Conditions

The site is 14.36 acres in size and is currently partially developed with buildings, paving, utilities, and landscaping. There are three remaining wetland areas located on site; two to the north and another to the west. The site slopes in a westerly direction at a fairly constant grade down toward a drainage channel which courses northerly toward Bradley Lake approximately 1/8 mile from the project site.

The soils on this site are comprised of approximately 2 to 18 inches of organic topsoil overlying glacial drift deposits of varying mixtures of sand, gravel, and silt. The soils are classified as Everett gravelly sand loam 0 to 6 percent slopes and Neilton gravelly loamy sand, 8 to 25 percent slopes. These soils have a potential for erosion when over 15 percent and exposed, and are therefore considered a hazard for erosion per the geotechnical report. More information on these soils can be found in the Soils Report.

2.2 Proposed Construction Activities

The proposal for this phase of the project is to construct two additional multi-unit buildings as part of a retirement community living center. Associated paving, utilities, and landscaping will be provided.

The water quality treatment for this site is contained in an existing wet pond located below the live storage in a combined wet/detention pond. These facilities were sized based on the WWHM as adopted by the City of Puyallup and developed by the Department of Ecology.

Construction activities will include critical area protection as necessary, site preparation, TESC installation, building construction, utility appurtenance installation, and paving. The pervious areas of the site consist of predominately wetland areas with native vegetation and grasses. There will also be added areas of landscaping and lawn. The schedule and phasing of BMPs during construction is provided in Section 4.0.

Stormwater runoff rates and volumes were calculated using WWHM hydrology model.

The following summarizes details regarding site areas:

▪ Total site area:	14.36 ± acres
▪ Percent impervious area before construction:	30%
▪ Percent impervious area after construction:	45%
▪ Percent pervious area after construction:	55%
▪ Native Vegetation to be retained:	3.5 acres (25%)
▪ Disturbed area during construction:	3.50± acres
▪ Disturbed area that is characterized as impervious (i.e., access roads, staging, parking):	0.25 acres
▪ Cut quantity:	14,000 cy
▪ Fill quantity:	2,100 cy
▪ Max Cut/Fill Depth	15 ± feet

All stormwater flow calculations are provided in Appendix F.

3.0 Construction Stormwater BMPs

3.1 The 14 BMP Elements

3.1.1 Element #1 – Preserve Vegetation/Mark Clearing Limits

To protect adjacent properties and to reduce the area of soil exposed to construction, the limits of construction will be clearly marked before land-disturbing activities begin. Areas that are to be preserved, as well as all sensitive areas and their buffers, shall be clearly delineated, both in the field and on the plans. The contractor shall mark the buffers as they are shown on the plans. The BMPs relevant to marking the clearing limits that will be applied for this project include:

- Preserving Natural Vegetation (BMP C101)
- Buffer Zones (BMP C102)
- High Visibility Plastic or Metal Fence (BMP C103)

The clearing limits shall be as shown on the plans and all vegetation outside of the clearing limits preserved. Native topsoil will be preserved in the undisturbed areas of the site.

Alternate BMPs for marking clearing limits are included in Appendix C as a quick reference tool for the onsite inspector in the event the BMP(s) listed above are deemed ineffective or inappropriate during construction to satisfy the requirements set forth in the General NPDES Permit (Appendix D). To avoid potential erosion and sediment control issues that may cause a violation(s) of the NPDES Construction Stormwater permit (as provided in Appendix D), the Certified Erosion and Sediment Control Lead will promptly initiate the implementation of one or more of the alternative BMPs listed in Appendix C after the first sign that existing BMPs are ineffective or failing.

3.1.2 Element #2 – Establish Construction Access

Construction access or activities occurring on unpaved areas shall be minimized, yet where necessary, access points shall be stabilized to minimize the tracking of sediment onto public roads, and wheel washing, street sweeping, and street cleaning shall be employed to prevent sediment from entering state waters. All wash wastewater shall be controlled on site. The specific BMPs related to establishing construction access that will be used on this project include:

- Stabilized Construction Entrance (BMP C105)
- Construction Haul Road (BMP C107)
- The roads shall be swept daily should sediment collect on them. Wheel washing (BMP C106), if needed, shall occur at locations where the sediment will be retained on site.

Alternate construction access BMPs are included in Appendix C as a quick reference tool for the onsite inspector in the event the BMP(s) listed above are deemed ineffective or inappropriate during construction to satisfy the requirements set forth in the General NPDES Permit (Appendix D). To avoid potential erosion and sediment control issues that may cause a violation(s) of the NPDES Construction Stormwater permit (as provided in Appendix D), the Certified Erosion and Sediment Control Lead will promptly initiate the implementation of one or more of the alternative BMPs listed in Appendix C after the first sign that existing BMPs are ineffective or failing.

3.1.3 Element #3 – Control Flow Rates

In order to protect the properties and waterways downstream of the project site, stormwater discharges from the site will be controlled by construction of one sediment trap for the northern portion of the site and one sediment pond for the southern portion of the site as some of the first items of construction. The wet cell of the permanent pond will be used for TESC. The allowable discharge from the sediment pond is 0.039 cfs with calculations shown in Appendix F of this document.

The project site is located west of the Cascade Mountain Crest. As such, the project must comply with Minimum Requirement 7.

In general, discharge rates of stormwater from the site will be controlled where increases in impervious area or soil compaction during construction could lead to downstream erosion, or where necessary to meet local agency stormwater discharge requirements (e.g., discharge to combined sewer systems).

See Appendix F for sediment trap sizing and sediment pond riser calculations.

Alternate flow control BMPs are included in Appendix C as a quick reference tool for the onsite inspector in the event the BMP(s) listed above are deemed ineffective or inappropriate during construction to satisfy the requirements set forth in the General NPDES Permit (Appendix D). To avoid potential erosion and sediment control issues that may cause a violation(s) of the NPDES Construction Stormwater permit (as provided in Appendix D), the Certified Erosion and Sediment Control Lead will promptly initiate the implementation of one or more of the alternative BMPs listed in Appendix C after the first sign that existing BMPs are ineffective or failing.

3.1.4 Element #4 – Install Sediment Controls

All stormwater runoff from disturbed areas shall be captured by an interceptor swale and conveyed through an appropriate sediment removal BMP before leaving the construction site or prior to being discharged to the downstream drainage course. The specific BMPs to be used for controlling sediment on this project include:

- Silt Fence (BMP C233)
- Interceptor Swales (BMP C200)
- Check Dams (BMP C207)

- Sediment Trap (BMP C240)
- Sediment Pond (BMP C241)
- Outlet Protection (BMP C209)

A silt fence shall be installed along the downstream perimeter of the proposed site.

In addition, sediment will be removed from paved areas in and adjacent to construction work areas manually or using mechanical sweepers, as needed, to minimize tracking of sediments on vehicle tires away from the site and to minimize washoff of sediments from adjacent streets in runoff.

Whenever possible, sediment-laden water shall be discharged into relatively level, vegetated areas onsite (BMP C240 paragraph 5, page 4-102). (Note: Vegetated wetlands shall not be used for this purpose).

In some cases, sediment discharge in concentrated runoff can be controlled using permanent stormwater BMPs (e.g., infiltration swales, ponds, trenches). Sediment loads can limit the effectiveness of some permanent stormwater BMPs, such as those used for infiltration or biofiltration; however, those BMPs designed to remove solids by settling (wet ponds or sediment ponds) can be used during the construction phase. When permanent stormwater BMPs will be used to control sediment discharge during construction, the structure will be protected from excessive sedimentation with adequate erosion and sediment control BMPs. Any accumulated sediment shall be removed after construction is complete and the remainder of the site has been stabilized.

The following BMPs will be implemented as end-of-pipe sediment controls as required to meet permitted turbidity limits in the site discharge(s). Prior to the implementation of these technologies, sediment sources and erosion control and soil stabilization BMP efforts will be maximized to reduce the need for end-of-pipe sedimentation controls.

- Construction Stormwater Filtration (BMP C251)
- Construction Stormwater Chemical Treatment (BMP C 250) (implemented only with prior written approval from Ecology).

Alternate sediment control BMPs are included in Appendix C as a quick reference tool for the onsite inspector in the event the BMP(s) listed above are deemed ineffective or inappropriate during construction to satisfy the requirements set forth in the General NPDES Permit (Appendix D). To avoid potential erosion and sediment control issues that may cause a violation(s) of the NPDES Construction Stormwater permit (as provided in Appendix D), the Certified Erosion and Sediment Control Lead will promptly initiate the implementation of one or more of the alternative BMPs listed in Appendix C after the first sign that existing BMPs are ineffective or failing.

3.1.5 Element #5 – Stabilize Soils

Exposed and unworked soils shall be stabilized with the application of effective BMPs to prevent erosion throughout the life of the project. The specific BMPs for soil stabilization that shall be used on this project include:

- Temporary and Permanent Seeding (BMP C120)
- Mulching (BMP C121)
- Plastic Covering (BMP C123)
- Dust Control (BMP C140)

Seeding shall occur on all areas to remain unworked pursuant to below. Dust shall be controlled if construction occurs during the summer. The project site is located west of the Cascade Mountain Crest. As such, no soils shall remain exposed and unworked for more than 7 days during the dry season (May 1 to September 30) and 2 days during the wet season (October 1 to April 30). Regardless of the time of year, all soils shall be stabilized at the end of the shift before a holiday or weekend if needed based on weather forecasts.

In general, cut and fill slopes will be stabilized as soon as possible and soil stockpiles will be temporarily covered with plastic sheeting. All stockpiled soils shall be stabilized from erosion, protected with sediment trapping measures, and where possible, be located away from storm drain inlets, waterways, and drainage channels.

Alternate soil stabilization BMPs are included in Appendix C as a quick reference tool for the onsite inspector in the event the BMP(s) listed above are deemed ineffective or inappropriate during construction to satisfy the requirements set forth in the General NPDES Permit (Appendix D). To avoid potential erosion and sediment control issues that may cause a violation(s) of the NPDES Construction Stormwater permit (as provided in Appendix D), the Certified Erosion and Sediment Control Lead will promptly initiate the implementation of one or more of the alternative BMPs listed in Appendix C after the first sign that existing BMPs are ineffective or failing.

3.1.6 Element #6 – Protect Slopes

All cut and fill slopes will be designed, constructed, and protected in a manner that minimizes erosion. To the east of the site, the grades slope towards the project site. There is approximately 1.01 acres of land to the east of the site in an area of approximately 35' x 1282' that drains onto this site. The land cover for this area is pervious landscaping and the 10-year flow in 15 minute timesteps is 0.0073 cfs. This flow spanning over the 1,282 linear feet is negligible and should not cause any erosion problems during construction.

The following specific BMPs will be used to protect slopes for this project:

- Temporary and Permanent Seeding (BMP C120)
- Interceptor Swales (BMP C200)

- Nets and Blankets (BMP C122)

Temporary and permanent seeding shall be used at all exposed areas pursuant to the prior mentioned schedule (seasonal restrictions). Swales shall be used to convey stormwater from the steep slopes to the east of the site into the northern sediment trap. Nets shall be used to stabilize slopes on the eastern portion of the site with steep slopes.

Alternate slope protection BMPs are included in Appendix C as a quick reference tool for the onsite inspector in the event the BMP(s) listed above are deemed ineffective or inappropriate during construction to satisfy the requirements set forth in the General NPDES Permit (Appendix D). To avoid potential erosion and sediment control issues that may cause a violation(s) of the NPDES Construction Stormwater permit (as provided in Appendix D), the Certified Erosion and Sediment Control Lead will promptly initiate the implementation of one or more of the alternative BMPs listed in Appendix C after the first sign that existing BMPs are ineffective or failing.

3.1.7 Element #7 – Protect Drain Inlets

All storm drain inlets and culverts made operable during construction shall be protected to prevent unfiltered or untreated water from entering the drainage conveyance system. However, the first priority is to keep all access roads clean of sediment and keep street wash water separate from entering storm drains until treatment can be provided. Storm Drain Inlet Protection (BMP C220) will be implemented for all drainage inlets and culverts that could potentially be impacted by sediment-laden runoff on and near the project site. The following inlet protection measures will be applied on this project:

- Excavated Drop Inlet Protection
- Block and Gravel Drop Inlet Protection
- Gravel and Wire Drop Inlet Protection
- Catch Basin Filters
- Culvert Inlet Sediment Trap

Inlets shall be inspected weekly at a minimum and daily during storm events.

If the BMP options listed above are deemed ineffective or inappropriate during construction to satisfy the requirements set forth in the General NPDES Permit (Appendix D), or if no BMPs are listed above but deemed necessary during construction, the Certified Erosion and Sediment Control Lead shall implement one or more of the alternative BMP inlet protection options listed in Appendix C.

3.1.8 Element #8 – Stabilize Channels and Outlets

Where site runoff is to be conveyed in channels, or discharged to a stream or some other natural drainage point, efforts will be taken to prevent downstream erosion. The specific BMPs for channel and outlet stabilization that shall be used on this project include:

- Site runoff shall be discharged to sediment pond (BMP C241) or sediment trap (BMP C240)
- Outlet protection (BMP C209)
- Grass-Lined Channels (BMP C201)

The site runoff shall be discharged into the wet pond area of the permanent detention pond on site. The sediment that is not collected by the interceptor swales and check dams will be collected in the wet pond and removed at the end of construction. The sediment pond discharges to the existing drainage channel located on the Lowe's property. The sediment trap discharges into the vegetated area between Wetland C and D through a gravel dispersal trench at the outlet to prevent erosion.

The project site is located west of the Cascade Mountain Crest. As such, all temporary on-site conveyance channels shall be designed, constructed, and stabilized following BMP C201 to prevent erosion from the expected peak 10 minute velocity of flow from a Type 1A, 10-year, 24-hour recurrence interval storm for the developed condition. Alternatively, the 10-year, 1-hour peak flow rate indicated by an approved continuous runoff simulation model, increased by a factor of 1.6, shall be used. Stabilization, including armoring material, adequate to prevent erosion of outlets, adjacent streambanks, slopes, and downstream reaches shall be provided at the outlets of all conveyance systems.

Alternate channel and outlet stabilization BMPs are included in Appendix C as a quick reference tool for the onsite inspector in the event the BMP(s) listed above are deemed ineffective or inappropriate during construction to satisfy the requirements set forth in the General NPDES Permit (Appendix D). To avoid potential erosion and sediment control issues that may cause a violation(s) of the NPDES Construction Stormwater permit (as provided in Appendix D), the Certified Erosion and Sediment Control Lead will promptly initiate the implementation of one or more of the alternative BMPs listed in Appendix C after the first sign that existing BMPs are ineffective or failing.

3.1.9 Element #9 – Control Pollutants

All pollutants, including waste materials and demolition debris, that occur onsite shall be handled and disposed of in a manner that does not cause contamination of stormwater. Good housekeeping and preventative measures will be taken to ensure that the site will be kept clean, well organized, and free of debris. If required, BMPs to be implemented to control specific sources of pollutants are discussed below. Vehicles, construction equipment, and/or petroleum product storage/dispensing:

- All vehicles, equipment, and petroleum product storage/dispensing areas will be inspected regularly to detect any leaks or spills, and to identify maintenance needs to prevent leaks or spills.
- On-site fueling tanks and petroleum product storage containers shall include secondary containment.

- Spill prevention measures, such as drip pans, will be used when conducting maintenance and repair of vehicles or equipment.
- In order to perform emergency repairs on site, temporary plastic will be placed beneath and, if raining, over the vehicle.
- Contaminated surfaces shall be cleaned immediately following any discharge or spill incident.

Demolition:

- Storm drain inlets vulnerable to stormwater discharge carrying dust, soil, or debris will be protected using Storm Drain Inlet Protection (BMP C220 as described above for Element 7).

Concrete and grout:

- Concrete trucks shall not be washed out onto the ground.
- Process water and slurry resulting from concrete work will be prevented from entering the waters of the State by implementing Concrete Handling measures (BMP C151).

3.1.10 Element #10 – Control Dewatering

All dewatering water from open cut excavation, tunneling, foundation work, trench, or underground vaults shall be discharged into a controlled conveyance system prior to discharge to the downstream drainage course. Channels will be stabilized, per Element #8. Clean, non-turbid dewatering water will not be routed through stormwater sediment ponds, and will be discharged directly into systems tributary to the receiving waters of the State in a manner that does not cause erosion, flooding, or a violation of State water quality standards in the receiving water. Highly turbid dewatering water from soils known or suspected to be contaminated, or from use of construction equipment, will require additional monitoring and treatment as required for the specific pollutants based on the receiving waters into which the discharge is occurring. Such monitoring is the responsibility of the contractor.

However, the dewatering of soils known to be free of contamination will trigger BMPs to trap sediment and reduce turbidity. At a minimum, geotextile fabric socks/bags/cells will be used to filter this material. At this time no dewatering is anticipated on this site.

If project dewatering is proposed to be discharged to the City sewer system, a "Construction Site Dewatering Permit" must be obtained by the contractor. Contact city of Puyallup source Control Specialist, Eric Rogers, at 253-847-5523 for permit application.

Alternate dewatering control BMPs are included in Appendix C as a quick reference tool for the onsite inspector in the event the BMP(s) listed above are deemed ineffective or inappropriate during construction to satisfy the requirements set forth in the General NPDES Permit (Appendix D). To avoid potential erosion and sediment control issues that may cause a violation(s) of the NPDES Construction Stormwater permit (as provided in Appendix D), the

Certified Erosion and Sediment Control Lead will promptly initiate the implementation of one or more of the alternative BMPs listed in Appendix C after the first sign that existing BMPs are ineffective or failing.

3.1.11 Element #11 – Maintain BMPs

All temporary and permanent erosion and sediment control BMPs shall be maintained and repaired as needed to assure continued performance of their intended function. Maintenance and repair shall be conducted in accordance with each particular BMP's specifications (See 2005 SWMM WW, Vol II). Visual monitoring of the BMPs will be conducted at least once every calendar week and within 24 hours of any rainfall event that causes a discharge from the site. If the site becomes inactive, and is temporarily stabilized, the inspection frequency will be reduced to once every month.

All temporary erosion and sediment control BMPs shall be removed within 30 days after the final site stabilization is achieved or after the temporary BMPs are no longer needed. Trapped sediment shall be removed or stabilized on site. Disturbed soil resulting from removal of BMPs or vegetation shall be permanently stabilized.

3.1.12 Element #12 – Manage the Project

Erosion and sediment control BMPs for this project have been designed based on the following principles:

- Design the project to fit the existing topography, soils, and drainage patterns.
- Emphasize erosion control rather than sediment control.
- Minimize the extent and duration of the area exposed.
- Keep runoff velocities low.
- Retain sediment on site.
- Thoroughly monitor site and maintain all ESC measures.
- Schedule major earthwork during the dry season.

In addition, project management will incorporate the key components listed below:

As this project site is located west of the Cascade Mountain Crest, the project will be managed according to the following key project components:

Phasing of Construction

- The construction project is being phased to the extent practicable in order to prevent soil erosion, and, to the maximum extent possible, the transport of sediment from the site during construction.

- Revegetation of exposed areas and maintenance of that vegetation shall be an integral part of the clearing activities during each phase of construction, per the Scheduling BMP (C 162).

Seasonal Work Limitations

- From October 1 through April 30, clearing, grading, and other soil disturbing activities shall only be permitted if shown to the satisfaction of the local permitting authority that silt-laden runoff will be prevented from leaving the site through a combination of the following:
 - Site conditions including existing vegetative coverage, slope, soil type, and proximity to receiving waters; and
 - Limitations on activities and the extent of disturbed areas; and
 - Proposed erosion and sediment control measures.
- Based on the information provided and/or local weather conditions, the local permitting authority may expand or restrict the seasonal limitation on site disturbance.
- The following activities are exempt from the seasonal clearing and grading limitations:
 - Routine maintenance and necessary repair of erosion and sediment control BMPs;
 - Routine maintenance of public facilities or existing utility structures that do not expose the soil or result in the removal of the vegetative cover to soil; and
 - Activities where there is 100 percent infiltration of surface water runoff within the site in approved and installed erosion and sediment control facilities.

Coordination with Utilities and Other Jurisdictions

- Care has been taken to coordinate with utilities, other construction projects, and the local jurisdiction in preparing this SWPPP and scheduling the construction work.

Inspection and Monitoring

- All BMPs shall be inspected, maintained, and repaired as needed to assure continued performance of their intended function. Site inspections shall be conducted by a person who is knowledgeable in the principles and practices of erosion and sediment control. This person has the necessary skills to:
 - Assess the site conditions and construction activities that could impact the quality of stormwater, and

- Assess the effectiveness of erosion and sediment control measures used to control the quality of stormwater discharges.
- A Certified Erosion and Sediment Control Lead shall be on-site or on-call at all times.
- Whenever inspection and/or monitoring reveals that the BMPs identified in this SWPPP are inadequate, due to the actual discharge of or potential to discharge a significant amount of any pollutant, appropriate BMPs or design changes shall be implemented as soon as possible.

Maintaining an Updated Construction SWPPP

- This SWPPP shall be retained on-site or within reasonable access to the site.
- The SWPPP shall be modified whenever there is a change in the design, construction, operation, or maintenance at the construction site that has, or could have, a significant effect on the discharge of pollutants to waters of the state.
- The SWPPP shall be modified if, during inspections or investigations conducted by the owner/operator, or the applicable local or state regulatory authority, it is determined that the SWPPP is ineffective in eliminating or significantly minimizing pollutants in stormwater discharges from the site. The SWPPP shall be modified as necessary to include additional or modified BMPs designed to correct problems identified. Revisions to the SWPPP shall be completed within seven (7) days following the inspection.

3.1.13 Element #13 – Construction Stormwater Chemical Treatment

Turbidity is difficult to control once fine particles are suspended in stormwater runoff from a construction site. Sedimentation ponds are effective at removing larger particulate matter by gravity settling, but are ineffective at removing smaller particulates such as clay and fine silt. Sediment ponds are typically designed to remove sediment no smaller than medium silt (0.02 mm). Chemical treatment may be used to reduce the turbidity of stormwater runoff.

Chemical treatment can reliably provide exceptional reductions of turbidity and associated pollutants. Very high turbidities can be reduced to levels comparable to what is found in streams during dry weather. Traditional BMPs used to control soil erosion and sediment loss from sites under development may not be adequate to ensure compliance with the water quality standard for turbidity in the receiving water. Chemical treatment may be required to protect streams from the impact of turbid stormwater discharges, especially when construction is to proceed through the wet season.

Formal written approval from Ecology and the Local Permitting Authority is required for the use of chemical treatment regardless of site size. The intention to use Chemical

Treatment shall be indicated on the Notice of Intent for coverage under the General Construction Permit. Chemical treatment systems should be designed as part of the Construction SWPPP, not after the fact. Chemical treatment may be used to correct problem sites in limited circumstances with formal written approval from Ecology and the Local Permitting Authority.

The SEPA review authority must be notified at the application phase of the project review (or the time that the SEPA determination on the project is performed) that chemical treatment is proposed. If it is added after this stage, an addendum will be necessary and may result in project approval delay.

See Appendix II-B Vol. II, Ecology 2005 SWMMWW for background information on chemical treatment.

Criteria for Chemical Treatment Product Use

Chemically treated stormwater discharged from construction sites must be nontoxic to aquatic organisms. The following protocol shall be used to evaluate chemicals proposed for stormwater treatment at construction sites. Authorization to use a chemical in the field based on this protocol does not relieve the applicant from responsibility for meeting all discharge and receiving water criteria applicable to a site.

- Treatment chemicals must be approved by EPA for potable water use.
- Petroleum-based polymers are prohibited.
- Prior to authorization for field use, jar tests shall be conducted to demonstrate that turbidity reduction necessary to meet the receiving water criteria can be achieved. Test conditions, including but not limited to raw water quality and jar test procedures, should be indicative of field conditions. Although these small-scale tests cannot be expected to reproduce performance under field conditions, they are indicative of treatment capability.
- Prior to authorization for field use, the chemically treated stormwater shall be tested for aquatic toxicity. Applicable procedures defined in Chapter 173-205 WAC, Whole Effluent Toxicity Testing and Limits, shall be used. Testing shall use stormwater from the construction site at which the treatment chemical is proposed for use or a water solution using soil from the proposed site.
- The proposed maximum dosage shall be at least a factor of five lower than the no observed effects concentration (NOEC).
- The approval of a proposed treatment chemical shall be conditional, subject to full-scale bioassay monitoring of treated stormwater at the construction site where the proposed treatment chemical is to be used.

- Treatment chemicals that have already passed the above testing protocol do not need to be reevaluated. Contact the Department of Ecology Regional Office for a list of treatment chemicals that have been evaluated and are currently approved for use.

Treatment System Design Considerations

The design and operation of a chemical treatment system should take into consideration the factors that determine optimum, cost-effective performance. It may not be possible to fully incorporate all of the classic concepts into the design because of practical limitations at construction sites. Nonetheless, it is important to recognize the following:

- The right chemical must be used at the right dosage. A dosage that is either too low or too high will not produce the lowest turbidity. There is an optimum dosage rate. This is a situation where the adage "adding more is always better" is not the case.
- The coagulant must be mixed rapidly into the water to insure proper dispersion.
- A flocculation step is important to increase the rate of settling, to produce the lowest turbidity, and to keep the dosage rate as low as possible.
- Too little energy input into the water during the flocculation phase results in flocs that are too small and/or insufficiently dense. Too much energy can rapidly destroy floc as it is formed.
- Since the volume of the basin is a determinant in the amount of energy per unit volume, the size of the energy input system can be too small relative to the volume of the basin.
- Care must be taken in the design of the withdrawal system to minimize outflow velocities and to prevent floc discharge. The discharge should be directed through a physical filter such as a vegetated swale that would catch any unintended floc discharge.

Treatment System Design

Chemical treatment systems shall be designed as batch treatment systems using either ponds or portable trailer-mounted tanks. Flow-through continuous treatment systems are not allowed at this time.

A chemical treatment system consists of the stormwater collection system (either temporary diversion or the permanent site drainage system), a storage pond, pumps, a chemical feed system, treatment cells, and interconnecting piping.

The treatment system shall use a minimum of two lined treatment cells. Multiple treatment cells allow for clarification of treated water while other cells are being filled or emptied. Treatment cells may be ponds or tanks. Ponds with constructed earthen embankments greater than six feet high require special engineering analyses. Portable tanks may also be suitable for some sites.

The following equipment should be located in an operations shed:

- the chemical injector;
- secondary containment for acid, caustic, buffering compound, and treatment chemical;
- emergency shower and eyewash, and
- monitoring equipment which consists of a pH meter and a turbidimeter.

Sizing Criteria

The combination of the storage pond or other holding area and treatment capacity should be large enough to treat stormwater during multiple day storm events. It is recommended that at a minimum the storage pond or other holding area should be sized to hold 1.5 times the runoff volume of the 10-year, 24-hour storm event. Bypass should be provided around the chemical treatment system to accommodate extreme storm events. Runoff volume shall be calculated using the methods presented in Volume 3, Chapter 2. If no hydrologic analysis is required for the site, the Rational Method may be used.

Primary settling should be encouraged in the storage pond. A forebay with access for maintenance may be beneficial.

There are two opposing considerations in sizing the treatment cells. A larger cell is able to treat a larger volume of water each time a batch is processed. However, the larger the cell the longer the time required to empty the cell. A larger cell may also be less effective at flocculation and therefore require a longer settling time. The simplest approach to sizing the treatment cell is to multiply the allowable discharge flow rate times the desired drawdown time. A 4-hour drawdown time allows one batch per cell per 8-hour work period, given 1 hour of flocculation followed by two hours of settling.

The permissible discharge rate governed by potential downstream effect can be used to calculate the recommended size of the treatment cells. The following discharge flow rate limits shall apply:

- If the discharge is directly or indirectly to a stream, the discharge flow rate shall not exceed 50 percent of the peak flow rate of the 2-year, 24-hour event for all storm events up to the 10-year, 24-hour event.

- If discharge is occurring during a storm event equal to or greater than the 10-year, 24-hour event, the allowable discharge rate is the peak flow rate of the 10-year, 24-hour event.
- Discharge to a stream should not increase the stream flow rate by more than 10 percent.
- If the discharge is directly to a lake, a major receiving water listed in Appendix C of Volume I, or to an infiltration system, there is no discharge flow limit.
- If the discharge is to a municipal storm drainage system, the allowable discharge rate may be limited by the capacity of the public system. It may be necessary to clean the municipal storm drainage system prior to the start of the discharge to prevent scouring solids from the drainage system.
- Runoff rates shall be calculated using the methods presented in Volume 3, Chapter 2 for the pre-developed condition. If no hydrologic analysis is required for the site, the Rational Method may be used.

Monitoring

The following monitoring shall be conducted. Test results shall be recorded on a daily log kept on site:

Operational Monitoring

- pH, conductivity (as a surrogate for alkalinity), turbidity and temperature of the untreated stormwater
- Total volume treated and discharged
- Discharge time and flow rate
- Type and amount of chemical used for pH adjustment
- Amount of polymer used for treatment
- Settling time

Compliance Monitoring

- pH and turbidity of the treated stormwater
- pH and turbidity of the receiving water

Biomonitoring: Treated stormwater shall be tested for acute (lethal) toxicity. Bioassays shall be conducted by a laboratory accredited by Ecology, unless otherwise approved by Ecology. **The**

performance standard for acute toxicity is no statistically significant difference in survival between the control and 100 percent chemically treated stormwater.

Acute toxicity tests shall be conducted with the following species and protocols:

- Fathead minnow, *Pimephales promelas* (96 hour static-renewal test, method: EPA/600/4-90/027F). Rainbow trout, *Oncorhynchus mykiss* (96 hour static-renewal test, method: EPA/600/4-90/027F) may be used as a substitute for fathead minnow.
- Daphnid, *Ceriodaphnia dubia*, *Daphnia pulex*, or *Daphnia magna* (48 hour static test, method: EPA/600/4-90/027F).

All toxicity tests shall meet quality assurance criteria and test conditions in the most recent versions of the EPA test method and Ecology Publication # WO-R-95-80, Laboratory Guidance and Whole Effluent Toxicity Test Review Criteria.

Bioassays shall be performed on the *first* five batches and on every tenth batch thereafter, or as otherwise approved by Ecology. Failure to meet the performance standard shall be immediately reported to Ecology.

Discharge Compliance: Prior to discharge, each batch of treated stormwater must be sampled and tested for compliance with pH and turbidity limits. These limits may be established by the water quality standards or a site-specific discharge permit. Sampling and testing for other pollutants may also be necessary at some sites. Turbidity must be within 5 NTUs of the background turbidity. Background is measured in the receiving water, upstream from the treatment process discharge point. pH must be within the range of 6.5 to 8.5 standard units and not cause a change in the pH of the receiving water of more than 0.2 standard units. It is often possible to discharge treated stormwater that has a lower turbidity than the receiving water and that matches the pH.

Treated stormwater samples and measurements shall be taken from the discharge pipe or another location representative of the nature of the treated stormwater discharge. Samples used for determining compliance with the water quality standards in the receiving water shall not be taken from the treatment pond prior to decanting. Compliance with the water quality standards is determined in the receiving water.

Operator Training

Each contractor who intends to use chemical treatment shall be trained by an experienced contractor on an active site for at least 40 hours.

Standard BMPs

Surface stabilization BMPs should be implemented on site to prevent significant erosion. All sites shall use a truck wheel wash to prevent tracking of sediment off site.

Sediment Removal and Disposal

- Sediment shall be removed from the storage or treatment cells as necessary. Typically, sediment removal is required at least once during a wet season and at the decommissioning of the cells. Sediment remaining in the cells between batches may enhance the settling process and reduce the required chemical dosage.
- Sediment may be incorporated into the site away from drainages.

3.1.14 Element #14 – Construction Stormwater Filtration

Filtration removes sediment from runoff originating from disturbed areas of the site.

Traditional BMPs used to control soil erosion and sediment loss from sites under development may not be adequate to ensure compliance with the water quality standard for turbidity in the receiving water. Filtration may be used in conjunction with gravity settling to remove sediment as small as fine silt (0.5 μm). The reduction in turbidity will be dependent on the particle size distribution of the sediment in the stormwater. In some circumstances, sedimentation and filtration may achieve compliance with the water quality standard for turbidity.

Unlike chemical treatment, the use of construction stormwater filtration does not require approval from Ecology.

Filtration may also be used in conjunction with polymer treatment in a portable system to assure capture of the flocculated solids.

Design and Installation Specifications – Background Information

Filtration with sand media has been used for over a century to treat water and wastewater. The use of sand filtration for treatment of stormwater has developed recently, generally to treat runoff from streets, parking lots, and residential areas. The application of filtration to construction stormwater treatment is currently under development.

Two types of filtration systems may be applied to construction stormwater treatment: rapid and slow. Rapid sand filters are the typical system used for water and wastewater treatment. They can achieve relatively high hydraulic flow rates, on the order of 2 to 20 gpm/sf, because they have automatic backwash systems to remove accumulated solids. In contrast, slow sand filters have very low hydraulic rates, on the order of 0.02 gpm/sf, because they do not have backwash systems. To date, slow sand filtration has generally been used to treat stormwater. Slow sand filtration is mechanically simple in comparison to rapid sand filtration but requires a much larger filter area.

Filtration Equipment

Sand media filters are available with automatic backwashing features that can filter to 50 μm particle size. Screen or bag filters can filter down to 5 μm . Fiber wound filters can remove

particles down to 0.5 µm. Filters should be sequenced from the largest to the smallest pore opening. Sediment removal efficiency will be related to particle size distribution in the stormwater.

Treatment Process Description

Stormwater is collected at interception point(s) on the site and is diverted to a sediment pond or tank for removal of large sediment and storage of the stormwater before it is treated by the filtration system. The stormwater is pumped from the trap, pond, or tank through the filtration system in a rapid sand filtration system. Slow sand filtration systems are designed as flow through systems using gravity.

If large volumes of concrete are being poured, pH adjustment may be necessary.

Maintenance Standards

Rapid sand filters typically have automatic backwash systems that are triggered by a pre-set pressure drop across the filter. If the backwash water volume is not large or substantially more turbid than the stormwater stored in the holding pond or tank, backwash return to the pond or tank may be appropriate. However, land application or another means of treatment and disposal may be necessary.

- Screen, bag, and fiber filters must be cleaned and/or replaced when they become clogged.
- Sediment shall be removed from the storage and/or treatment ponds as necessary. Typically, sediment removal is required once or twice during a wet season and at the decommissioning of the ponds.

3.2 Site Specific BMPs

Site specific BMPs are shown on the TESC Plan Sheets and Details in Appendix A. These site specific plan sheets will be updated annually.

4.0 Construction Phasing and BMP Implementation

The BMP implementation schedule will be driven by the construction schedule. The following provides a sequential list of the proposed construction schedule milestones and the corresponding BMP implementation schedule. The list contains key milestones such as wet season construction.

The BMP implementation schedule listed below is keyed to proposed phases of the construction project, and reflects differences in BMP installations and inspections that relate to wet season construction. The project site is located west of the Cascade Mountain Crest. As such, the dry season is considered to be from May 1 to September 30 and the wet season is considered to be from October 1 to April 30.

- Estimate of Construction start date: August 2023
- Estimate of Construction finish date: August 2024
- Mobilize equipment on site: _____
- Mobilize and store all ESC and soil stabilization products (store materials on hand BMP C150): _____
- Install ESC measures: _____
- Install stabilized construction entrance: _____
- Begin clearing and grubbing: _____
- Temporary erosion control measures (hydroseeding): _____
- Site inspections reduced to monthly: _____
- Begin concrete pour and implement BMP C151: _____
- Excavate and install new utilities and services (Phase 1): _____
- Complete utility construction: _____
- Begin implementing soil stabilization and sediment control BMPs throughout the site in preparation for wet season: _____
- **WET SEASON STARTS:** October 1, 2023

5.0 Pollution Prevention Team

5.1 Roles and Responsibilities

The pollution prevention team consists of personnel responsible for implementation of the SWPPP, including the following:

- Certified Erosion and Sediment Control Lead (CESCL) – primary contractor contact, responsible for site inspections (BMPs, visual monitoring, sampling, etc.); to be called upon in case of failure of any ESC measures.
- Resident Engineer – For projects with engineered structures only (sediment ponds/traps, sand filters, etc.): site representative for the owner that is the project's supervising engineer responsible for inspections and issuing instructions and drawings to the contractor's site supervisor or representative
- Emergency Ecology Contact – individual to be contacted at Ecology in case of emergency. Go to the following website to get the name and number for the Ecology contact information:
<http://www.ecy.wa.gov/org.html>.
- Emergency Owner Contact – individual that is the site owner or representative of the site owner to be contacted in the case of an emergency.
- Non-Emergency Ecology Contact – individual that is the site owner or representative of the site owner than can be contacted if required.
- Monitoring Personnel – personnel responsible for conducting water quality monitoring; for most sites this person is also the Certified Erosion and Sediment Control Lead.

5.2 Team Members

Names and contact information for those identified as members of the pollution prevention team are provided in the following table.

Title	Name(s)	Phone Number
Certified Erosion and Sediment Control Lead (CESCL)	TBD	
Resident Engineer	Dan Balmelli	(425) 251-6222
Emergency Ecology Contact	Clay Keown	(360) 407-6048
Emergency Owner Contact	Kevin Anderson	(206) 870-1100
Non-Emergency Ecology Contact	Cara Visintainer	(425) 251-6222
Monitoring Personnel	TBD	

6.0 Site Inspections and Monitoring

Monitoring includes visual inspection, monitoring for water quality parameters of concern, and documentation of the inspection and monitoring findings in a site log book. A site log book will be maintained for all on-site construction activities and will include:

- A record of the implementation of the SWPPP and other permit requirements;
- Site inspections; and,
- Stormwater quality monitoring.

For convenience, the inspection form and water quality monitoring forms included in this SWPPP include the required information for the site log book. This SWPPP may function as the site log book if desired, or the forms may be separated and included in a separate site log book. However, if separated, the site log book but must be maintained on-site or within reasonable access to the site and be made available upon request to Ecology or the local jurisdiction.

6.1 Site Inspection

All BMPs will be inspected, maintained, and repaired as needed to assure continued performance of their intended function. The inspector will be a Certified Erosion and Sediment Control Lead (CESCL) per BMP C160. The name and contact information for the CESCL is provided in Section 5 of this SWPPP.

Site inspection will occur in all areas disturbed by construction activities and at all stormwater discharge points. Stormwater will be examined for the presence of suspended sediment, turbidity, discoloration, and oily sheen. The site inspector will evaluate and document the effectiveness of the installed BMPs and determine if it is necessary to repair or replace any of the BMPs to improve the quality of stormwater discharges. All maintenance and repairs will be documented in the site log book or forms provided in this document. All new BMPs or design changes will be documented in the SWPPP as soon as possible.

6.1.1 Site Inspection Frequency

Site inspections will be conducted at least once a week and within 24 hours following any rainfall event which causes a discharge of stormwater from the site. For sites with temporary stabilization measures, the site inspection frequency can be reduced to once every month.

6.1.2 Site Inspection Documentation

The site inspector will record each site inspection using the site log inspection forms provided in Appendix E. The site inspection log forms may be separated from this SWPPP document, but will be maintained on-site or within reasonable access to the site and be made available upon request to Ecology or the local jurisdiction.

6.2 Stormwater Quality Monitoring

6.2.1 Turbidity Sampling

Monitoring requirements for the proposed project will include either turbidity or water transparency sampling to monitor site discharges for water quality compliance with the 2005 Construction Stormwater General Permit (Appendix D). Sampling will be conducted at all discharge points at least once per calendar week.

Turbidity or transparency monitoring will follow the analytical methodologies described in Section S4 of the 2005 Construction Stormwater General Permit (Appendix D). The key benchmark values that require action are 25 NTU for turbidity (equivalent to 32 cm transparency) and 250 NTU for turbidity (equivalent to 6 cm transparency). If the 25 NTU benchmark for turbidity (equivalent to 32 cm transparency) is exceeded, the following steps will be conducted:

1. Ensure all BMPs specified in this SWPPP are installed and functioning as intended.
2. Assess whether additional BMPs should be implemented, and document revisions to the SWPPP as necessary.
3. Sample discharge location daily until the analysis results are less than 25 NTU (turbidity) or greater than 32 cm (transparency).

If the turbidity is greater than 25 NTU (or transparency is less than 32 cm) but less than 250 NTU (transparency greater than 6 cm) for more than 3 days, additional treatment BMPs will be implemented within 24 hours of the third consecutive sample that exceeded the benchmark.

If the 250 NTU benchmark for turbidity (or less than 6 cm transparency) is exceeded at any time, the following steps will be conducted:

1. Notify Ecology by phone within 24 hours of analysis (see Section 5.0 of this SWPPP for contact information).
2. Continue daily sampling until the turbidity is less than 25 NTU (or transparency is greater than 32 cm).
3. Initiate additional treatment BMPs such as off-site treatment, infiltration, filtration, and chemical treatment within 24 hours of the first 250 NTU exceedance.
4. Implement additional treatment BMPs as soon as possible, but within 7 days of the first 250 NTU exceedance.
5. Describe inspection results and remedial actions taken in the site log book and in monthly discharge monitoring reports as described in Section 7.0 of this SWPPP.

6.2.2 pH Sampling

Stormwater runoff will be monitored for pH starting on the first day of any activity that includes more than 40 yards of poured or recycled concrete, or after the application of "Engineered Soils" such as Portland cement treated base, cement kiln dust, or fly ash. This does not include fertilizers. For concrete work, pH monitoring will start the first day concrete is poured and continue until 3 weeks after the last pour. For engineered soils, the pH monitoring period begins when engineered soils are first exposed to precipitation and continue until the area is fully stabilized.

Stormwater samples will be collected daily from all points of discharge from the site and measured for pH using a calibrated pH meter, pH test kit, or wide range pH indicator paper. If the measured pH is 8.5 or greater, the following steps will be conducted:

1. Prevent the high pH water from entering storm drains or surface water.
2. Adjust or neutralize the high pH water if necessary using appropriate technology such as CO₂ sparging (liquid or dry ice).
3. Contact Ecology if chemical treatment other than CO₂ sparging is planned.

7.0 Reporting and Recordkeeping

7.1 Recordkeeping

7.1.1 Site Log Book

A site log book will be maintained for all on-site construction activities and will include:

- A record of the implementation of the SWPPP and other permit requirements;
- Site inspections; and,
- Stormwater quality monitoring.

For convenience, the inspection form and water quality monitoring forms included in this SWPPP include the required information for the site logbook.

7.1.2 Records Retention

Records of all monitoring information (site log book, inspection reports/checklists, etc.), this Stormwater Pollution Prevention Plan, and any other documentation of compliance with permit requirements will be retained during the life of the construction project and for a minimum of three years following the termination of permit coverage in accordance with permit condition S5.C.

7.1.3 Access to Plans and Records

The SWPPP, General Permit, Notice of Authorization letter, and Site Log Book will be retained on site or within reasonable access to the site and will be made immediately available upon request to Ecology or the local jurisdiction. A copy of this SWPPP will be provided to Ecology within 14 days of receipt of a written request for the SWPPP from Ecology. Any other information requested by Ecology will be submitted within a reasonable time. A copy of the SWPPP or access to the SWPPP will be provided to the public when requested in writing in accordance with Permit Condition S5.G.

7.1.4 Updating the SWPPP

In accordance with Conditions S3, S4.B, and S9.B.3 of the General Permit, this SWPPP will be modified if the SWPPP is ineffective in eliminating or significantly minimizing pollutants in stormwater discharges from the site or there has been a change in design, construction, operation, or maintenance at the site that has a significant effect on the discharge, or potential for discharge, of pollutants to the waters of the State. The SWPPP will be modified within seven days of determination based on inspection(s) that additional or modified BMPs are necessary to correct problems identified, and an updated timeline for BMP implementation will be prepared.

7.2 Reporting

7.2.1 Discharge Monitoring Reports

Discharge Monitoring Reports (DMRs) will be submitted to Ecology monthly. If there was no discharge during a given monitoring period the DMR will be submitted as required, reporting “No Discharge”. The DMR due date is fifteen (15) days following the end of each calendar month.

7.2.2 Notification of Noncompliance

If any of the terms and conditions of the permit are not met, and it causes a threat to human health or the environment, the following steps will be taken in accordance with permit section S5.F:

1. Ecology will be notified within 24 hours of the failure to comply.
2. Immediate action will be taken to stop or correct the noncompliance issue and to correct the problem. If applicable, sampling and analysis of any noncompliance will be repeated immediately and the results submitted to Ecology within five (5) days of becoming aware of the violation.
3. A detailed written report describing the noncompliance will be submitted to Ecology within five (5) days, unless requested earlier by Ecology.
4. Anytime turbidity sampling indicated turbidity is 250 NTUs or greater, or water transparency is 6cm or less, ecology will be notified by phone within 24 hours of analysis.

Appendix A – Site Plans

EXISTING SITE AND TESC PLAN SOUTH

FOR

PHASE 2 - WESLEY BRADLEY PARK

MATCH LINE SEE SHEET C2

MATCH LINE SEE SHEET C2

1"=30'

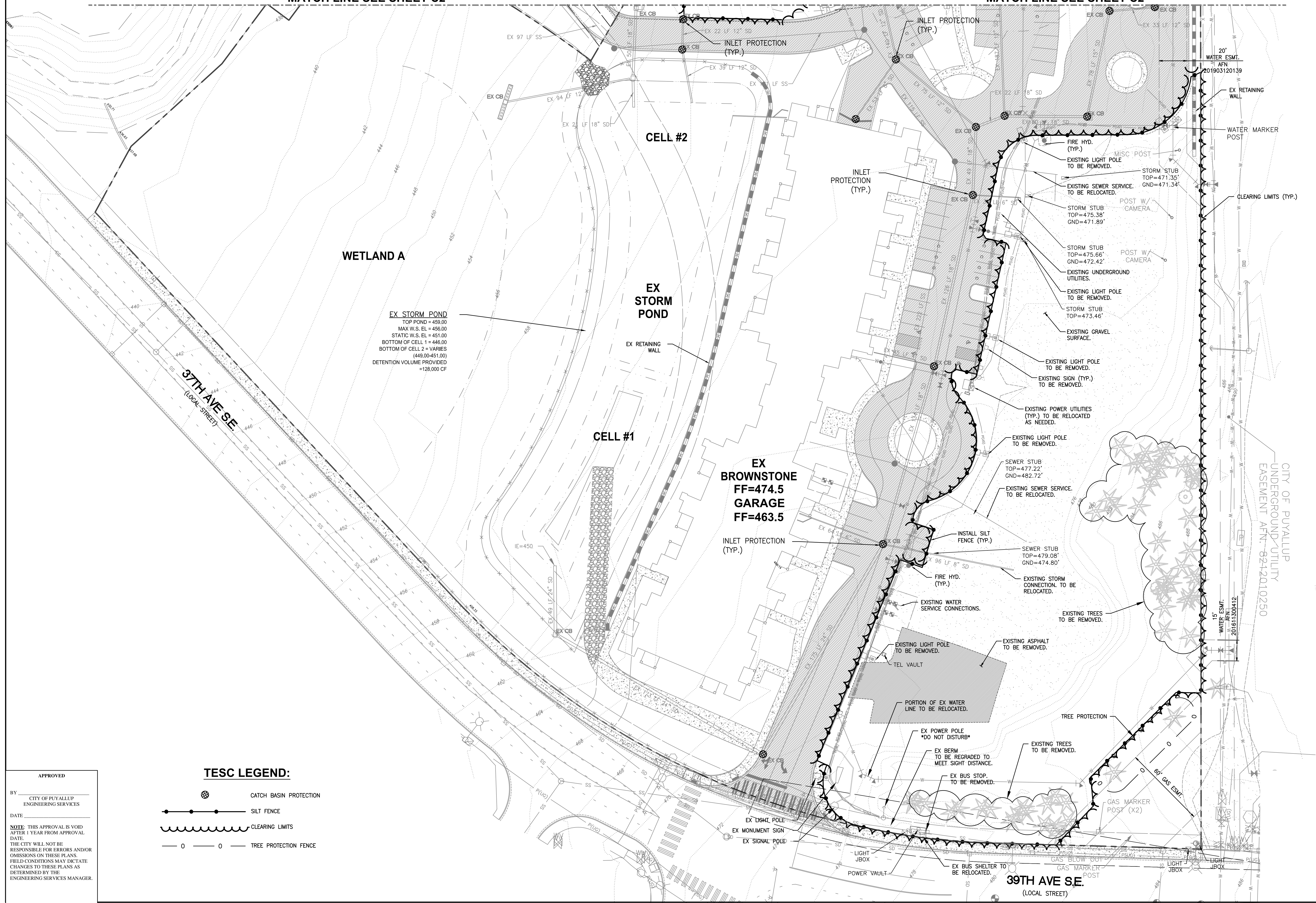
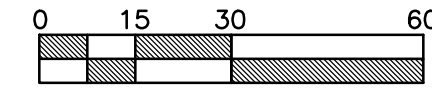

TESC LEGEND:

- CATCH BASIN PROTECTION
- SILT FENCE
- CLEARING LIMITS
- TREE PROTECTION FENCE

APPROVED

BY _____
 CITY OF PUYALLUP
 ENGINEERING SERVICES

DATE _____

NOTE: THIS APPROVAL IS VOID
 AFTER 1 YEAR FROM APPROVAL
 DATE.
 THE CITY WILL NOT BE
 RESPONSIBLE FOR ERRORS AND/OR
 OMISSIONS ON THESE PLANS.
 FIELD CONDITIONS MAY DICTATE
 CHANGES TO THESE PLANS AS
 DETERMINED BY THE
 ENGINEERING SERVICES MANAGER.

Revision
 No. Date By Cld. Appr.

Title: **EXISTING SITE AND TESC PLAN SOUTH**
FOR
CIVIL PLANS
PHASE 2 - WESLEY BRADLEY PARK

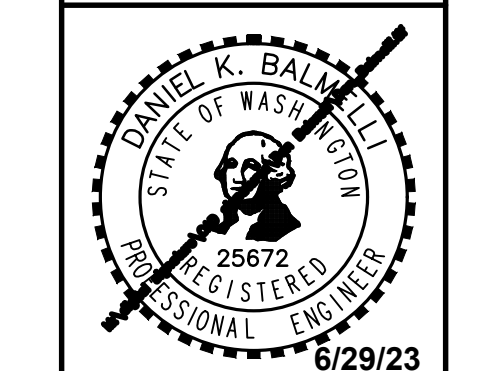

For: **WESLEY HOMES**
815 SOUTH 216TH STREET
DES MOINES, WA 98190
(206) 870-1209

Scale: Horizontal 1" = 30' Vertical N/A

Designed CK Draw BOK Checked CMV Approved DKB Date 6/29/23

Barghausen Consulting Engineers, Inc.
 18215 72nd Avenue South
 Kent, WA 98032
 425.251.6222 barghausen.com

Job Number **16718**
 Sheet **C3** of **C19**

P:\16000A\16718\engineering\Phase 2\16718-e.dwg 6/29/2023 5:44 PM BKUNZ

TESC NOTES AND DETAILS FOR PHASE 2 - WESLEY BRADLEY PARK

SOIL STABILIZATION AND REVEGETATION

EXPOSED AREAS AND SOIL STOCKPILES MUST BE STABILIZED ACCORDING TO THE FOLLOWING SCHEDULE:

- FROM APRIL 1 TO OCTOBER 31 ALL DISTURBED AREAS AT FINAL GRADE AND ALL EXPOSED AREAS THAT ARE SCHEDULED TO REMAIN UNWORKED FOR MORE THAN 30 DAYS SHALL BE STABILIZED WITHIN 10 DAYS.
- FROM NOVEMBER 1 TO MARCH 31 ALL EXPOSED SOILS AT FINAL GRADE SHALL BE STABILIZED IMMEDIATELY USING PERMANENT OR TEMPORARY MEASURES. EXPOSED SOILS WITH AN AREA GREATER THAN 5,000 SQUARE FEET THAT ARE SCHEDULED TO REMAIN UNWORKED FOR MORE THAN 24 HOURS AND EXPOSED AREAS OF LESS THAN 5,000 SQUARE FEET THAT WILL REMAIN UNWORKED FOR MORE THAN SEVEN (7) DAYS SHALL BE STABILIZED IMMEDIATELY.

ALL DISTURBED AREAS WHICH ARE NOT PLANNED TO BE CONSTRUCTED ON WITHIN 90 DAYS FROM TIME OF CLEARING AND GRADING SHALL BE REVEGETATED WITH THE NATIVE VEGETATION.

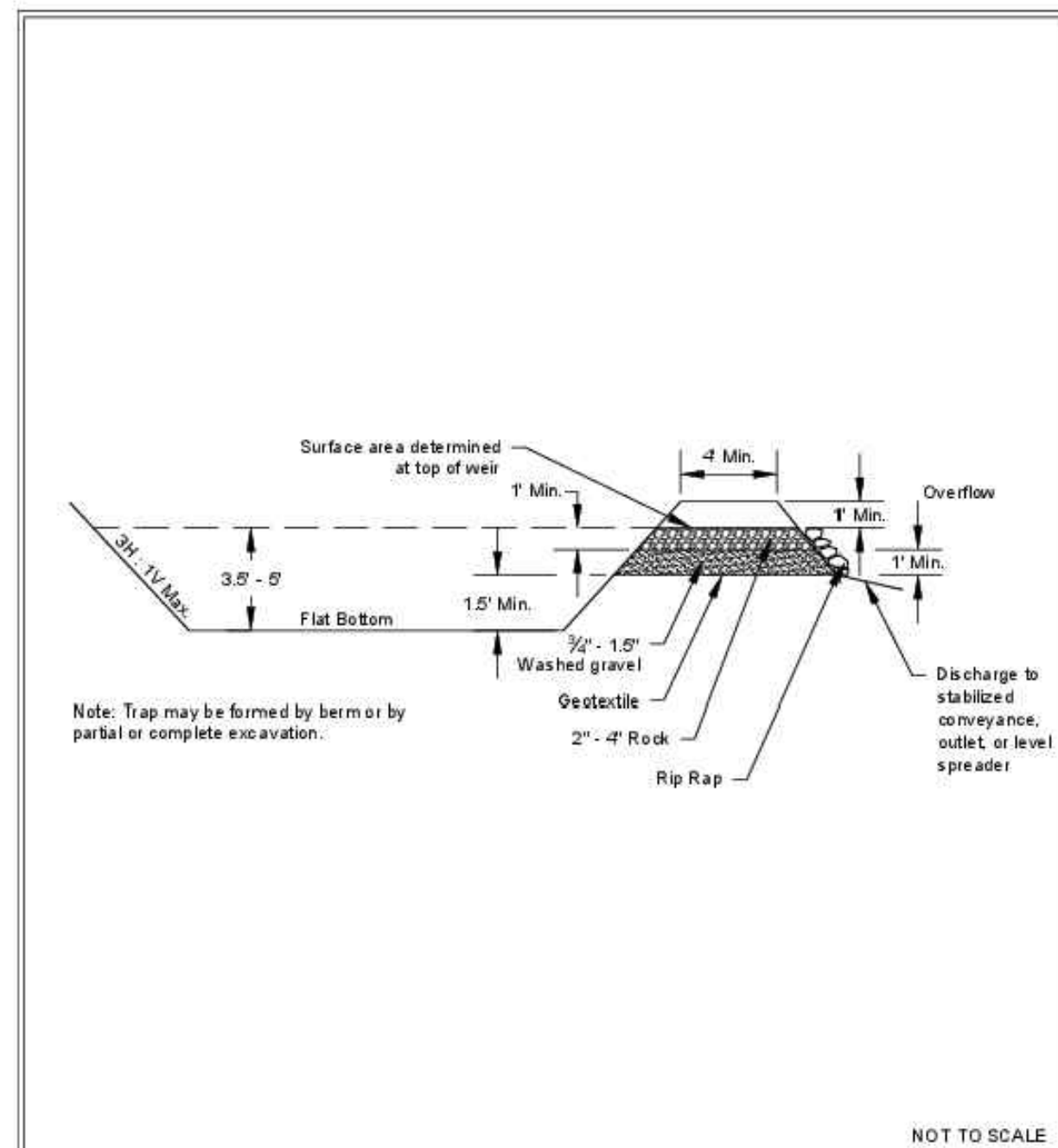

NOT TO SCALE

Figure II-4.2.16
Cross Section of Sediment Trap
Revised November 2015

Please see <http://www.ecy.wa.gov/copyright.htm> for copyright notice including permissions, limitation of liability, and disclaimer.

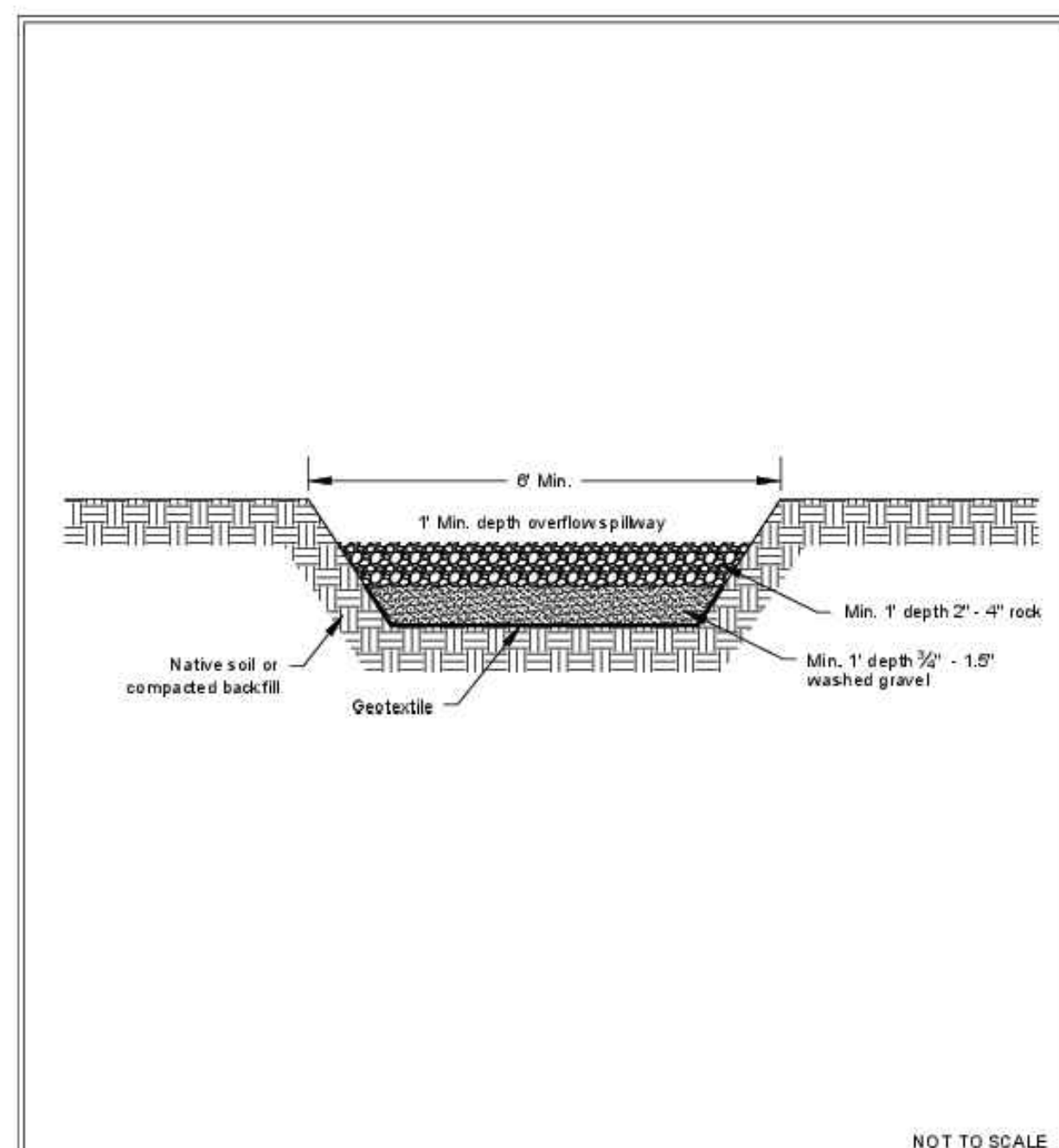

NOT TO SCALE

Figure II-4.2.17
Sediment Trap Outlet
Revised November 2015

Please see <http://www.ecy.wa.gov/copyright.htm> for copyright notice including permissions, limitation of liability, and disclaimer.

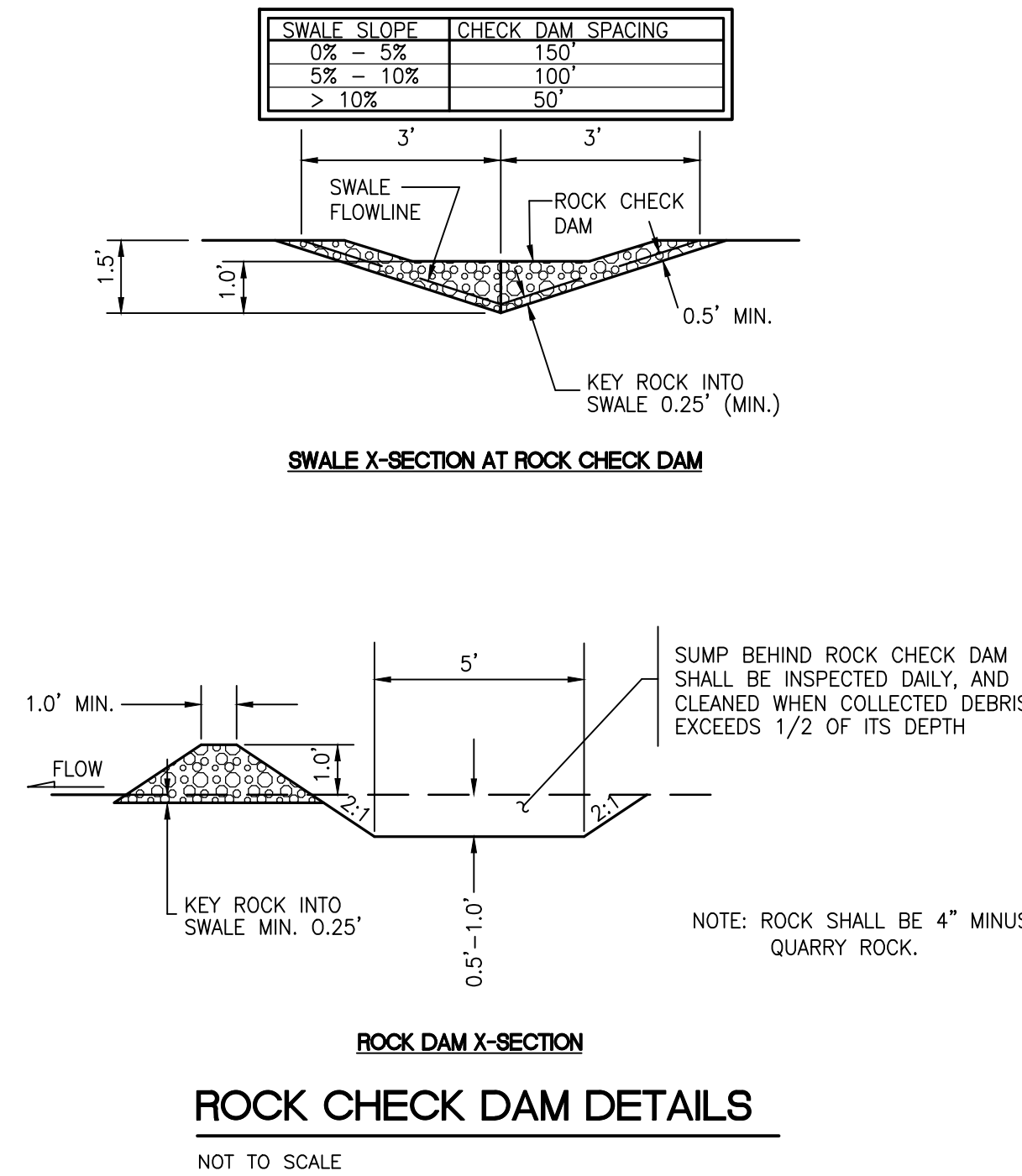

NOT TO SCALE

SWALE X-SECTION AT ROCK CHECK DAM
ROCK CHECK DAM DETAILS

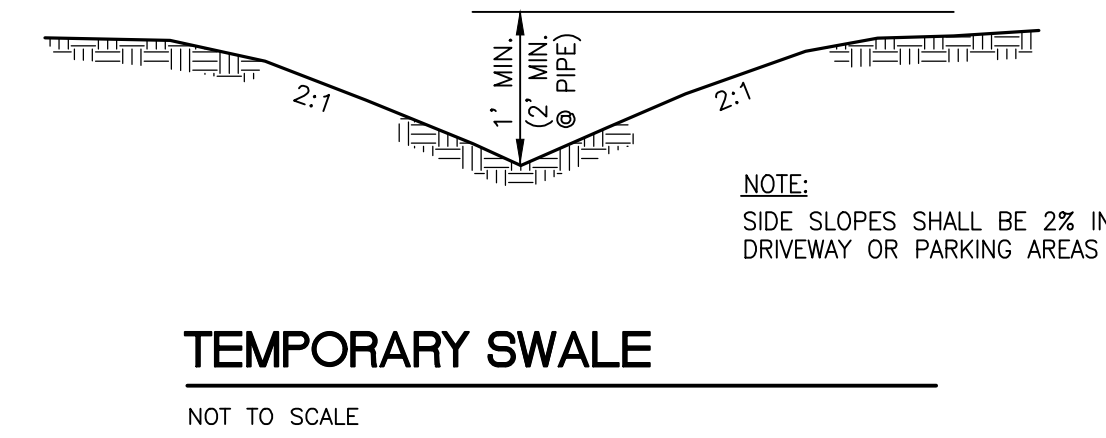

NOT TO SCALE

TEMPORARY SWALE

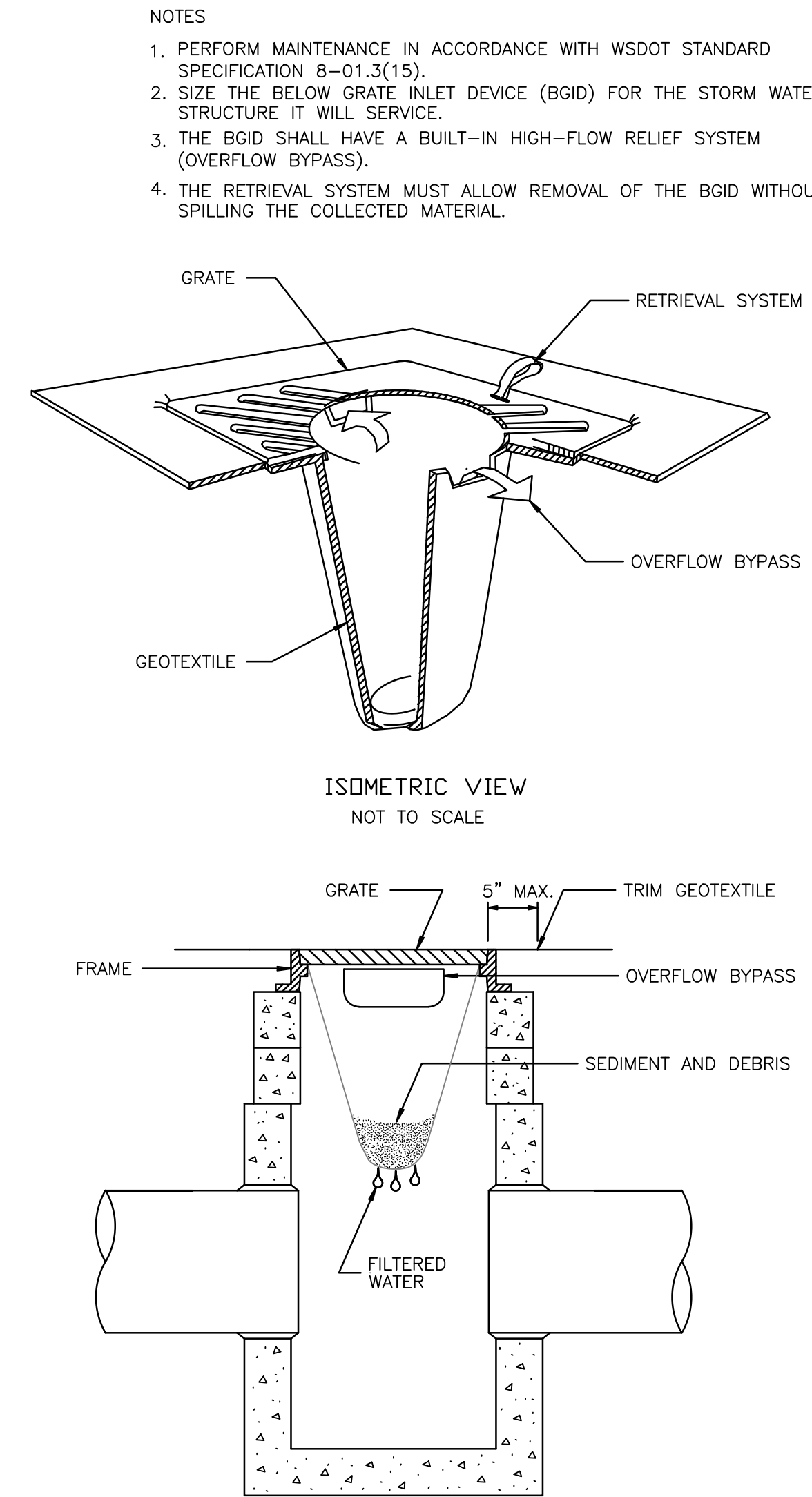

NOT TO SCALE

ISOMETRIC VIEW
NOT TO SCALE

CROSS SECTION
NOT TO SCALE

STORM DRAIN INLET PROTECTION
PREFABRICATED BELOW GRATE INLET DEVICE DETAILS
WSDOT STANDARD PLAN I-7

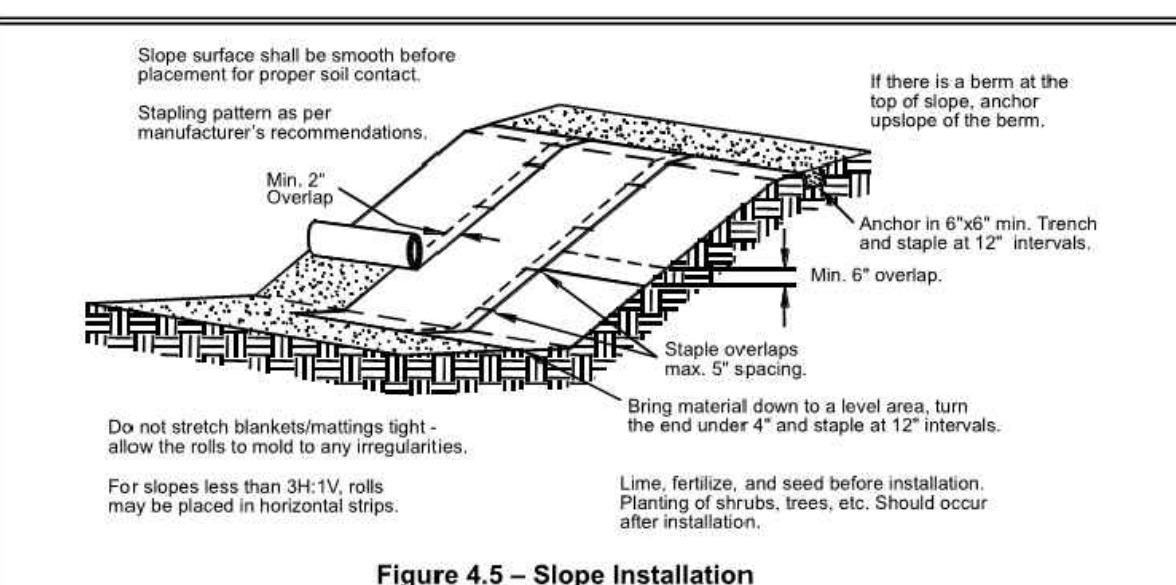
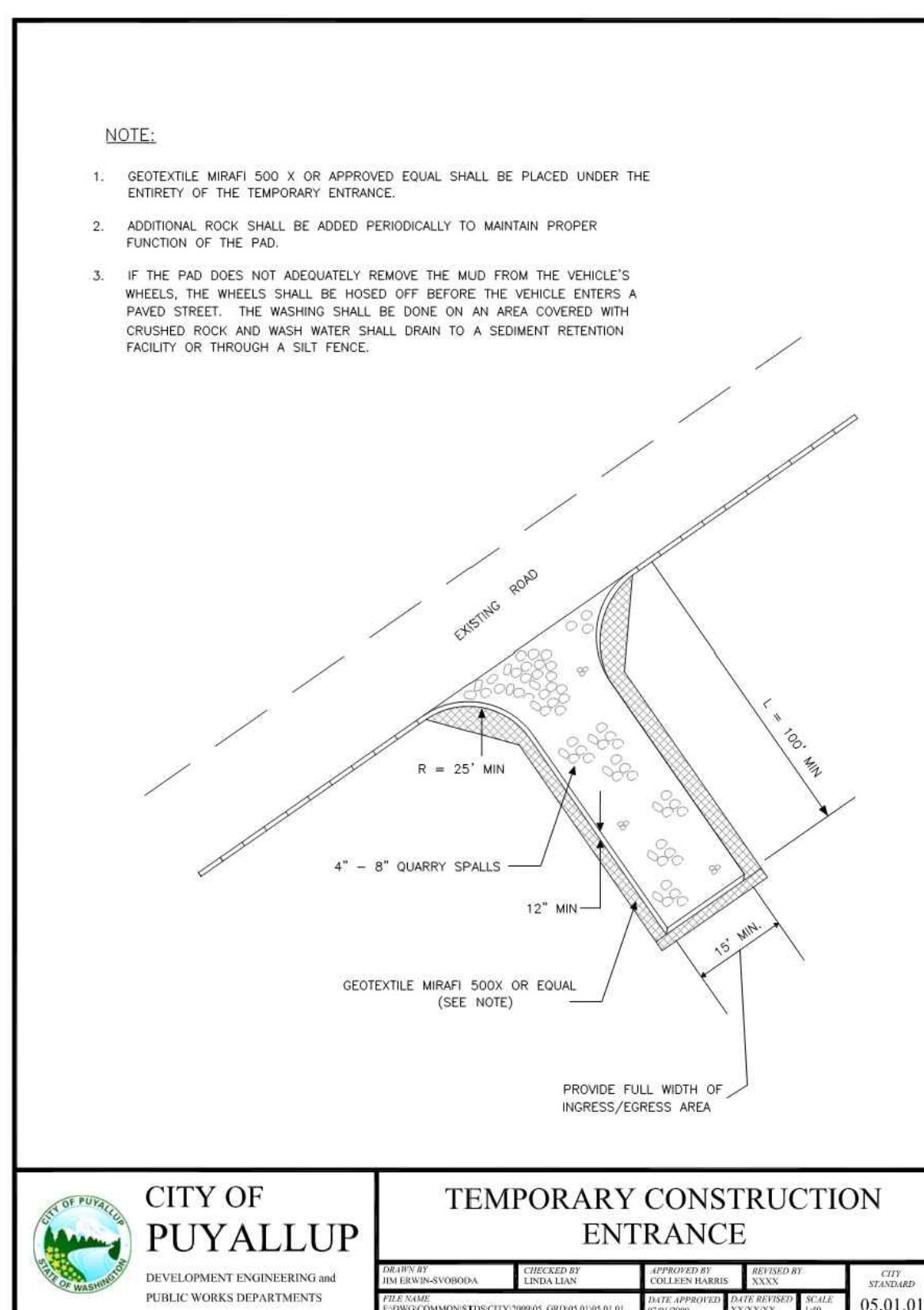
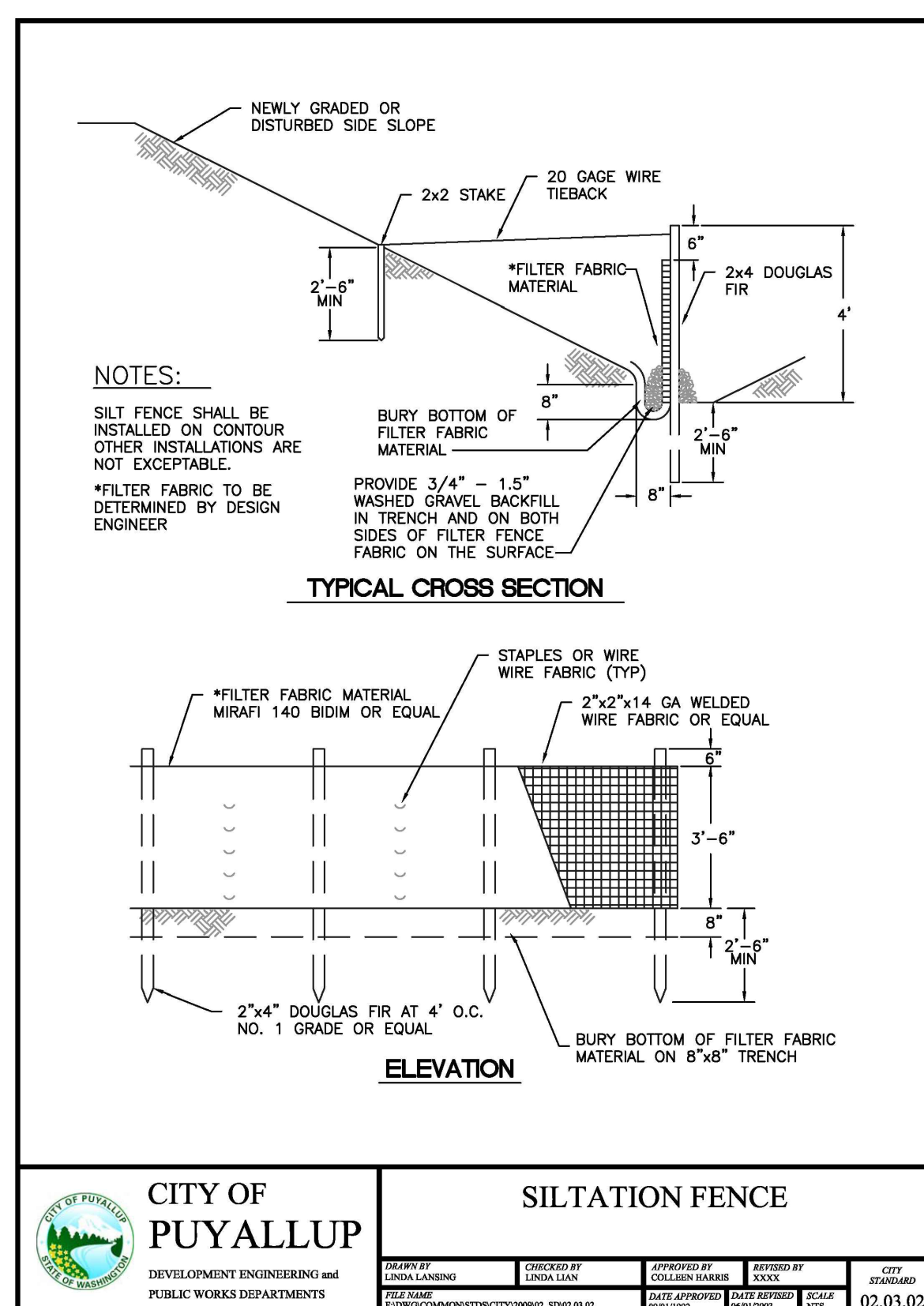

Figure 4.5 - Slope Installation



TEMPORARY CONSTRUCTION ENTRANCE



SILTATION FENCE

Revision	By	Appr.
No.	Date	

CONSTRUCTION NOTES
FOR
CIVIL PLANS
PHASE 2 - WESLEY BRADLEY PARK

WESLEY HOMES
815 SOUTH 216TH STREET
DES MOINES, WA 98190
(206) 870-1209

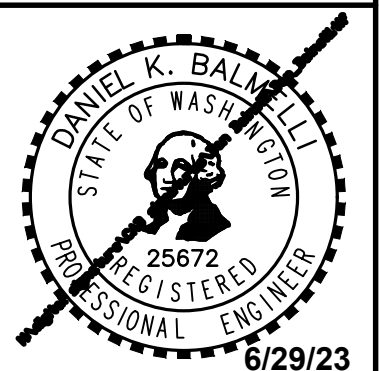

Scale:	Horizontal	N/A	Vertical	C4					
Designed	CK	Drawn	BOK	Checked	CMV	Approved	DKB	Date	6/29/23

Barghausen Consulting Engineers, Inc.
18215 72nd Avenue South
Kent, WA 98032
425.251.6222
barghausen.com

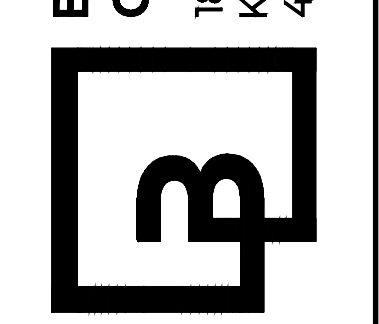

Job Number	16718
Sheet	C4 of C19

APPROVED

BY _____
CITY OF PUYALLUP
ENGINEERING SERVICES

DATE _____

NOTE: THIS APPROVAL IS VOID AFTER 1 YEAR FROM APPROVAL DATE.
THE CITY WILL NOT BE RESPONSIBLE FOR ERRORS AND/OR OMISSIONS ON THESE PLANS. FIELD CONDITIONS MAY DICTATE CHANGES TO THESE PLANS AS DETERMINED BY THE ENGINEERING SERVICES MANAGER.



DEPARTMENT OF ECOLOGY
State of Washington

Please see <http://www.ecy.wa.gov/copyright.htm> for copyright notice including permissions, limitation of liability, and disclaimer.

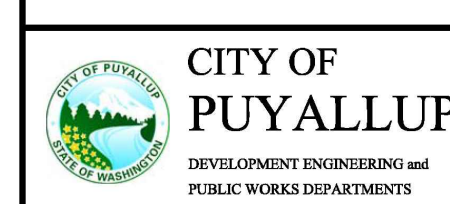

CITY OF PUYALLUP
DEVELOPMENT ENGINEERING and PUBLIC WORKS DEPARTMENTS



DEPARTMENT OF ECOLOGY
State of Washington

Please see <http://www.ecy.wa.gov/copyright.htm> for copyright notice including permissions, limitation of liability, and disclaimer.

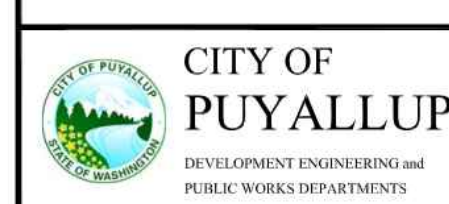

CITY OF PUYALLUP
DEVELOPMENT ENGINEERING and PUBLIC WORKS DEPARTMENTS

Appendix B – Construction BMPs

Preserving Natural Vegetation (BMP C101)
Buffer Zones (BMP C102)
High Visibility Fence (BMP C103)
Stabilized Construction Entrance (BMP C105)
Wheel Wash (BMP C106)
Construction Road/Parking Area Stabilization (BMP C107)
Temporary and Permanent Seeding (BMP C120)
Mulching (BMP C121)
Nets and Blankets (BMP C122)
Plastic Covering (BMP C123)
Dust Control (BMP C140)
Materials on Hand (BMP C150)
Concrete Handling (BMP C151)
Sawcutting and Surfacing Pollution Prevention (BMP C152)
Interceptor Swales (BMP C200)
Channel Lining (BMP C202)
Water Bars (BMP C203)
Pipe Slope Drains (BMP C204)
Grass-Lined Channels (BMP C201)
Check Dams (BMP C207)
Outlet Protection (BMP C209)
Strom Drain Inlet Protection (BMP C220)
Gravel Filter Berm (BMP C232)
Silt Fence (BMP C233)
Sediment trap (BMP C240)
Sediment pond (BMP C241)
Construction Stormwater Chemical Treatment (BMP C250)
Construction Stormwater Filtration (BMP C251)
High pH Neutralization Using CO₂ (BMP C252)

BMP C101: Preserving Natural Vegetation

Purpose The purpose of preserving natural vegetation is to reduce erosion wherever practicable. Limiting site disturbance is the single most effective method for reducing erosion. For example, conifers can hold up to about 50 percent of all rain that falls during a storm. Up to 20-30 percent of this rain may never reach the ground but is taken up by the tree or evaporates. Another benefit is that the rain held in the tree can be released slowly to the ground after the storm.

Conditions of Use Natural vegetation should be preserved on steep slopes, near perennial and intermittent watercourses or swales, and on building sites in wooded areas.

- As required by local governments.
- Phase construction to preserve natural vegetation on the project site for as long as possible during the construction period.

Design and Installation Specifications Natural vegetation can be preserved in natural clumps or as individual trees, shrubs and vines.

The preservation of individual plants is more difficult because heavy equipment is generally used to remove unwanted vegetation. The points to remember when attempting to save individual plants are:

- Is the plant worth saving? Consider the location, species, size, age, vigor, and the work involved. Local governments may also have ordinances to save natural vegetation and trees.
- Fence or clearly mark areas around trees that are to be saved. It is preferable to keep ground disturbance away from the trees at least as far out as the dripline.

Plants need protection from three kinds of injuries:

- *Construction Equipment* - This injury can be above or below the ground level. Damage results from scarring, cutting of roots, and compaction of the soil. Placing a fenced buffer zone around plants to be saved prior to construction can prevent construction equipment injuries.
- *Grade Changes* - Changing the natural ground level will alter grades, which affects the plant's ability to obtain the necessary air, water, and minerals. Minor fills usually do not cause problems although sensitivity between species does vary and should be checked. Trees can typically tolerate fill of 6 inches or less. For shrubs and other plants, the fill should be less.

When there are major changes in grade, it may become necessary to supply air to the roots of plants. This can be done by placing a layer of gravel and a tile system over the roots before the fill is made. A tile system protects a tree from a raised grade. The tile system should be

laid out on the original grade leading from a dry well around the tree trunk. The system should then be covered with small stones to allow air to circulate over the root area.

Lowering the natural ground level can seriously damage trees and shrubs. The highest percentage of the plant roots are in the upper 12 inches of the soil and cuts of only 2-3 inches can cause serious injury. To protect the roots it may be necessary to terrace the immediate area around the plants to be saved. If roots are exposed, construction of retaining walls may be needed to keep the soil in place. Plants can also be preserved by leaving them on an undisturbed, gently sloping mound. To increase the chances for survival, it is best to limit grade changes and other soil disturbances to areas outside the dripline of the plant.

- *Excavations* - Protect trees and other plants when excavating for drainfields, power, water, and sewer lines. Where possible, the trenches should be routed around trees and large shrubs. When this is not possible, it is best to tunnel under them. This can be done with hand tools or with power augers. If it is not possible to route the trench around plants to be saved, then the following should be observed:

Cut as few roots as possible. When you have to cut, cut clean. Paint cut root ends with a wood dressing like asphalt base paint if roots will be exposed for more than 24-hours.

Backfill the trench as soon as possible.

Tunnel beneath root systems as close to the center of the main trunk to preserve most of the important feeder roots.

Some problems that can be encountered with a few specific trees are:

- Maple, Dogwood, Red alder, Western hemlock, Western red cedar, and Douglas fir do not readily adjust to changes in environment and special care should be taken to protect these trees.
- The windthrow hazard of Pacific silver fir and madrona is high, while that of Western hemlock is moderate. The danger of windthrow increases where dense stands have been thinned. Other species (unless they are on shallow, wet soils less than 20 inches deep) have a low windthrow hazard.
- Cottonwoods, maples, and willows have water-seeking roots. These can cause trouble in sewer lines and infiltration fields. On the other hand, they thrive in high moisture conditions that other trees would not.
- Thinning operations in pure or mixed stands of Grand fir, Pacific silver fir, Noble fir, Sitka spruce, Western red cedar, Western hemlock, Pacific dogwood, and Red alder can cause serious disease problems. Disease can become established through damaged limbs, trunks, roots,

and freshly cut stumps. Diseased and weakened trees are also susceptible to insect attack.

Maintenance Standards

Inspect flagged and/or fenced areas regularly to make sure flagging or fencing has not been removed or damaged. If the flagging or fencing has been damaged or visibility reduced, it shall be repaired or replaced immediately and visibility restored.

- If tree roots have been exposed or injured, “prune” cleanly with an appropriate pruning saw or loppers directly above the damaged roots and recover with native soils. Treatment of sap flowing trees (fir, hemlock, pine, soft maples) is not advised as sap forms a natural healing barrier.

BMP C102: Buffer Zones

Purpose

Creation of an undisturbed area or strip of natural vegetation or an established suitable planting that will provide a living filter to reduce soil erosion and runoff velocities.

Conditions of Use

Natural buffer zones are used along streams, wetlands and other bodies of water that need protection from erosion and sedimentation. Vegetative buffer zones can be used to protect natural swales and can be incorporated into the natural landscaping of an area.

Critical-areas buffer zones should not be used as sediment treatment areas. These areas shall remain completely undisturbed. The local permitting authority may expand the buffer widths temporarily to allow the use of the expanded area for removal of sediment.

Design and Installation Specifications

- Preserving natural vegetation or plantings in clumps, blocks, or strips is generally the easiest and most successful method.
- Leave all unstable steep slopes in natural vegetation.
- Mark clearing limits and keep all equipment and construction debris out of the natural areas and buffer zones. Steel construction fencing is the most effective method in protecting sensitive areas and buffers. Alternatively, wire-backed silt fence on steel posts is marginally effective. Flagging alone is typically not effective.
- Keep all excavations outside the dripline of trees and shrubs.
- Do not push debris or extra soil into the buffer zone area because it will cause damage from burying and smothering.
- Vegetative buffer zones for streams, lakes or other waterways shall be established by the local permitting authority or other state or federal permits or approvals.

Maintenance Standards

Inspect the area frequently to make sure flagging remains in place and the area remains undisturbed. Replace all damaged flagging immediately.

BMP C103: High Visibility Fence

Purpose

Fencing is intended to:

1. Restrict clearing to approved limits.
2. Prevent disturbance of sensitive areas, their buffers, and other areas required to be left undisturbed.
3. Limit construction traffic to designated construction entrances, exits, or internal roads.
4. Protect areas where marking with survey tape may not provide adequate protection.

Conditions of Use

To establish clearing limits plastic, fabric, or metal fence may be used:

- At the boundary of sensitive areas, their buffers, and other areas required to be left uncleared.
- As necessary to control vehicle access to and on the site.

Design and Installation Specifications

High visibility plastic fence shall be composed of a high-density polyethylene material and shall be at least four feet in height. Posts for the fencing shall be steel or wood and placed every 6 feet on center (maximum) or as needed to ensure rigidity. The fencing shall be fastened to the post every six inches with a polyethylene tie. On long continuous lengths of fencing, a tension wire or rope shall be used as a top stringer to prevent sagging between posts. The fence color shall be high visibility orange. The fence tensile strength shall be 360 lbs./ft. using the ASTM D4595 testing method.

If appropriate install fabric silt fence in accordance with [BMP C233](#) to act as high visibility fence. Silt fence shall be at least 3 feet high and must be highly visible to meet the requirements of this BMP.

Metal fences shall be designed and installed according to the manufacturer's specifications.

Metal fences shall be at least 3 feet high and must be highly visible.

Fences shall not be wired or stapled to trees.

Maintenance Standards

If the fence has been damaged or visibility reduced, it shall be repaired or replaced immediately and visibility restored.

BMP C105: Stabilized Construction Entrance / Exit

Purpose

Stabilized Construction entrances are established to reduce the amount of sediment transported onto paved roads by vehicles or equipment. This is done by constructing a stabilized pad of quarry spalls at entrances and exits for construction sites.

Conditions of Use

Construction entrances shall be stabilized wherever traffic will be entering or leaving a construction site if paved roads or other paved areas are within 1,000 feet of the site.

For residential construction provide stabilized construction entrances for each residence, rather than only at the main subdivision entrance. Stabilized surfaces shall be of sufficient length/width to provide vehicle access/parking, based on lot size/configuration.

On large commercial, highway, and road projects, the designer should include enough extra materials in the contract to allow for additional stabilized entrances not shown in the initial Construction SWPPP. It is difficult to determine exactly where access to these projects will take place; additional materials will enable the contractor to install them where needed.

Design and Installation Specifications

See [Figure 4.1.1](#) for details. Note: the 100' minimum length of the entrance shall be reduced to the maximum practicable size when the size or configuration of the site does not allow the full length (100').

Construct stabilized construction entrances with a 12-inch thick pad of 4-inch to 8-inch quarry spalls, a 4-inch course of asphalt treated base (ATB), or use existing pavement. Do not use crushed concrete, cement, or calcium chloride for construction entrance stabilization because these products raise pH levels in stormwater and concrete discharge to surface waters of the State is prohibited.

A separation geotextile shall be placed under the spalls to prevent fine sediment from pumping up into the rock pad. The geotextile shall meet the following standards:

Grab Tensile Strength (ASTM D4751)	200 psi min.
Grab Tensile Elongation (ASTM D4632)	30% max.
Mullen Burst Strength (ASTM D3786-80a)	400 psi min.
AOS (ASTM D4751)	20-45 (U.S. standard sieve size)

- Consider early installation of the first lift of asphalt in areas that will paved; this can be used as a stabilized entrance. Also consider the installation of excess concrete as a stabilized entrance. During large concrete pours, excess concrete is often available for this purpose.

- Fencing (see [BMP C103](#)) shall be installed as necessary to restrict traffic to the construction entrance.
- Whenever possible, the entrance shall be constructed on a firm, compacted subgrade. This can substantially increase the effectiveness of the pad and reduce the need for maintenance.
- Construction entrances should avoid crossing existing sidewalks and back of walk drains if at all possible. If a construction entrance must cross a sidewalk or back of walk drain, the full length of the sidewalk and back of walk drain must be covered and protected from sediment leaving the site.

Maintenance Standards

Quarry spalls shall be added if the pad is no longer in accordance with the specifications.

- If the entrance is not preventing sediment from being tracked onto pavement, then alternative measures to keep the streets free of sediment shall be used. This may include replacement/cleaning of the existing quarry spalls, street sweeping, an increase in the dimensions of the entrance, or the installation of a wheel wash.
- Any sediment that is tracked onto pavement shall be removed by shoveling or street sweeping. The sediment collected by sweeping shall be removed or stabilized on site. The pavement shall not be cleaned by washing down the street, except when high efficiency sweeping is ineffective and there is a threat to public safety. If it is necessary to wash the streets, the construction of a small sump to contain the wash water shall be considered. The sediment would then be washed into the sump where it can be controlled.
- Perform street sweeping by hand or with a high efficiency sweeper. Do not use a non-high efficiency mechanical sweeper because this creates dust and throws soils into storm systems or conveyance ditches.
- Any quarry spalls that are loosened from the pad, which end up on the roadway shall be removed immediately.
- If vehicles are entering or exiting the site at points other than the construction entrance(s), fencing (see [BMP C103](#)) shall be installed to control traffic.
- Upon project completion and site stabilization, all construction accesses intended as permanent access for maintenance shall be permanently stabilized.

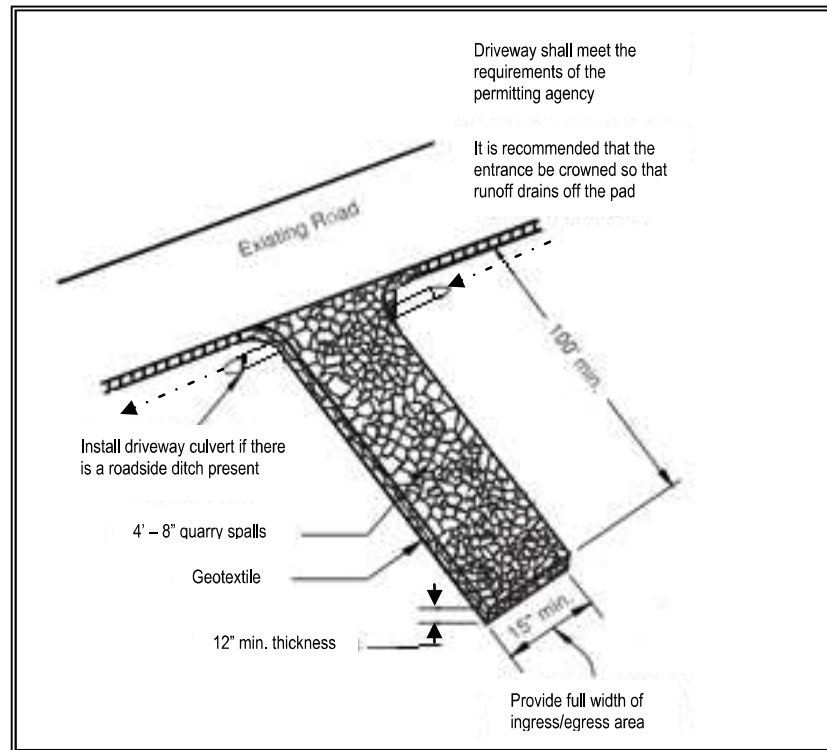

Figure 4.1.1 – Stabilized Construction Entrance

Approved as Equivalent

Ecology has approved products as able to meet the requirements of [BMP C105](#). The products did not pass through the Technology Assessment Protocol – Ecology (TAPE) process. Local jurisdictions may choose not to accept this product approved as equivalent, or may require additional testing prior to consideration for local use. The products are available for review on Ecology’s website at <http://www.ecy.wa.gov/programs/wq/stormwater/newtech/equivalent.html>

BMP C106: Wheel Wash

Purpose

Wheel washes reduce the amount of sediment transported onto paved roads by motor vehicles.

Conditions of Use

When a stabilized construction entrance (see [BMP C105](#)) is not preventing sediment from being tracked onto pavement.

- Wheel washing is generally an effective BMP when installed with careful attention to topography. For example, a wheel wash can be detrimental if installed at the top of a slope abutting a right-of-way where the water from the dripping truck can run unimpeded into the street.

- Pressure washing combined with an adequately sized and surfaced pad with direct drainage to a large 10-foot x 10-foot sump can be very effective.
- Discharge wheel wash or tire bath wastewater to a separate on-site treatment system that prevents discharge to surface water, such as closed-loop recirculation or upland land application, or to the sanitary sewer with local sewer district approval.
- Wheel wash or tire bath wastewater should not include wastewater from concrete washout areas.

***Design and
Installation
Specifications***

Suggested details are shown in [Figure 4.1.2](#). The Local Permitting Authority may allow other designs. A minimum of 6 inches of asphalt treated base (ATB) over crushed base material or 8 inches over a good subgrade is recommended to pave the wheel wash.

Use a low clearance truck to test the wheel wash before paving. Either a belly dump or lowboy will work well to test clearance.

Keep the water level from 12 to 14 inches deep to avoid damage to truck hubs and filling the truck tongues with water.

Midpoint spray nozzles are only needed in extremely muddy conditions.

Wheel wash systems should be designed with a small grade change, 6- to 1-inches for a 10-foot-wide pond, to allow sediment to flow to the low side of pond to help prevent re-suspension of sediment. A drainpipe with a 2- to 3-foot riser should be installed on the low side of the pond to allow for easy cleaning and refilling. Polymers may be used to promote coagulation and flocculation in a closed-loop system. Polyacrylamide (PAM) added to the wheel wash water at a rate of 0.25 - 0.5 pounds per 1,000 gallons of water increases effectiveness and reduces cleanup time. If PAM is already being used for dust or erosion control and is being applied by a water truck, the same truck can be used to change the wash water.

***Maintenance
Standards***

The wheel wash should start out the day with fresh water.

The wash water should be changed a minimum of once per day. On large earthwork jobs where more than 10-20 trucks per hour are expected, the wash water will need to be changed more often.

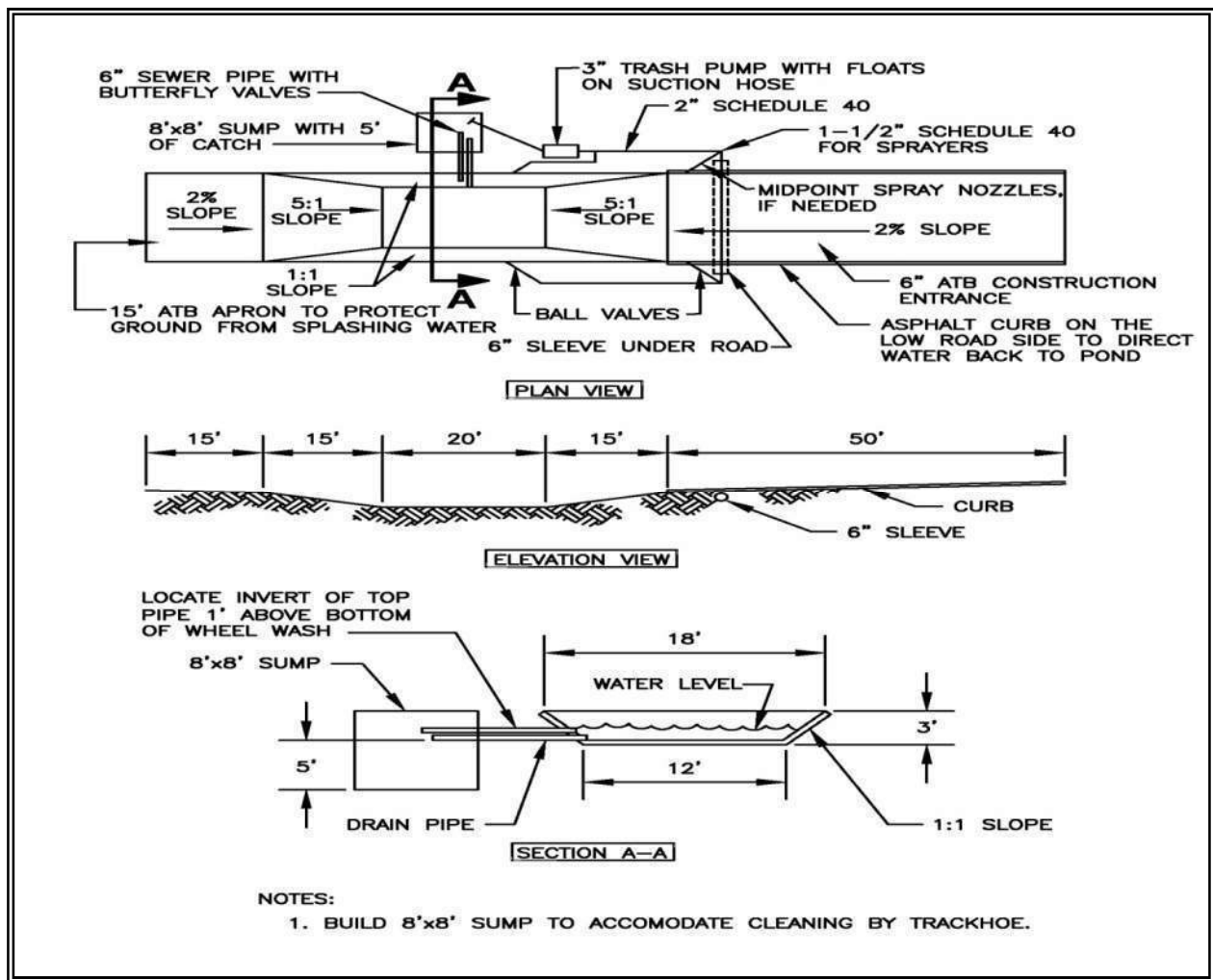

Figure 4.1.2 – Wheel Wash

Notes:

1. Asphalt construction entrance 6 in. asphalt treated base (ATB).
2. 3-inch trash pump with floats on the suction hose.
3. Midpoint spray nozzles, if needed.
4. 6-inch sewer pipe with butterfly valves. Bottom one is a drain. Locate top pipe's invert 1 foot above bottom of wheel wash.
5. 8 foot x 8 foot sump with 5 feet of catch. Build so the sump can be cleaned with a trackhoe.
6. Asphalt curb on the low road side to direct water back to pond.
7. 6-inch sleeve under road.
8. Ball valves.
9. 15 foot. ATB apron to protect ground from splashing water.

BMP C107: Construction Road/Parking Area Stabilization

<i>Purpose</i>	Stabilizing subdivision roads, parking areas, and other on-site vehicle transportation routes immediately after grading reduces erosion caused by construction traffic or runoff.
<i>Conditions of Use</i>	Roads or parking areas shall be stabilized wherever they are constructed, whether permanent or temporary, for use by construction traffic. <ul style="list-style-type: none">• High Visibility Fencing (see BMP C103) shall be installed, if necessary, to limit the access of vehicles to only those roads and parking areas that are stabilized.
<i>Design and Installation Specifications</i>	<ul style="list-style-type: none">• On areas that will receive asphalt as part of the project, install the first lift as soon as possible.• A 6-inch depth of 2- to 4-inch crushed rock, gravel base, or crushed surfacing base course shall be applied immediately after grading or utility installation. A 4-inch course of asphalt treated base (ATB) may also be used, or the road/parking area may be paved. It may also be possible to use cement or calcium chloride for soil stabilization. If cement or cement kiln dust is used for roadbase stabilization, pH monitoring and BMPs (BMPs C252 and C253) are necessary to evaluate and minimize the effects on stormwater. If the area will not be used for permanent roads, parking areas, or structures, a 6-inch depth of hog fuel may also be used, but this is likely to require more maintenance. Whenever possible, construction roads and parking areas shall be placed on a firm, compacted subgrade.• Temporary road gradients shall not exceed 15 percent. Roadways shall be carefully graded to drain. Drainage ditches shall be provided on each side of the roadway in the case of a crowned section, or on one side in the case of a super-elevated section. Drainage ditches shall be directed to a sediment control BMP.• Rather than relying on ditches, it may also be possible to grade the road so that runoff sheet-flows into a heavily vegetated area with a well-developed topsoil. Landscaped areas are not adequate. If this area has at least 50 feet of vegetation that water can flow through, then it is generally preferable to use the vegetation to treat runoff, rather than a sediment pond or trap. The 50 feet shall not include wetlands or their buffers. If runoff is allowed to sheetflow through adjacent vegetated areas, it is vital to design the roadways and parking areas so that no concentrated runoff is created.• Storm drain inlets shall be protected to prevent sediment-laden water entering the storm drain system (see BMP C220).
<i>Maintenance Standards</i>	Inspect stabilized areas regularly, especially after large storm events. Crushed rock, gravel base, etc. shall be added as required to maintain a

stable driving surface and to stabilize any areas that have eroded.

Following construction, these areas shall be restored to pre-construction condition or better to prevent future erosion.

Perform street cleaning at the end of each day or more often if necessary.

BMP C120: Temporary and Permanent Seeding

Purpose

Seeding reduces erosion by stabilizing exposed soils. A well-established vegetative cover is one of the most effective methods of reducing erosion.

Conditions of Use

Use seeding throughout the project on disturbed areas that have reached final grade or that will remain unworked for more than 30 days.

The optimum seeding windows for western Washington are April 1 through June 30 and September 1 through October 1.

Between July 1 and August 30 seeding requires irrigation until 75 percent grass cover is established.

Between October 1 and March 30 seeding requires a cover of mulch with straw or an erosion control blanket until 75 percent grass cover is established.

Review all disturbed areas in late August to early September and complete all seeding by the end of September. Otherwise, vegetation will not establish itself enough to provide more than average protection.

- Mulch is required at all times for seeding because it protects seeds from heat, moisture loss, and transport due to runoff. Mulch can be applied on top of the seed or simultaneously by hydroseeding. See [BMP C121: Mulching](#) for specifications.
- Seed and mulch, all disturbed areas not otherwise vegetated at final site stabilization. Final stabilization means the completion of all soil disturbing activities at the site and the establishment of a permanent vegetative cover, or equivalent permanent stabilization measures (such as pavement, riprap, gabions or geotextiles) which will prevent erosion.

Design and Installation Specifications

Seed retention/detention ponds as required.

Install channels intended for vegetation before starting major earthwork and hydroseed with a Bonded Fiber Matrix. For vegetated channels that will have high flows, install erosion control blankets over hydroseed. Before allowing water to flow in vegetated channels, establish 75 percent vegetation cover. If vegetated channels cannot be established by seed before water flow; install sod in the channel bottom—over hydromulch and erosion control blankets.

- Confirm the installation of all required surface water control measures to prevent seed from washing away.
- Hydroseed applications shall include a minimum of 1,500 pounds per acre of mulch with 3 percent tackifier. See [BMP C121: Mulching](#) for specifications.
- Areas that will have seeding only and not landscaping may need compost or meal-based mulch included in the hydroseed in order to establish vegetation. Re-install native topsoil on the disturbed soil surface before application.
- When installing seed via hydroseeding operations, only about 1/3 of the seed actually ends up in contact with the soil surface. This reduces the ability to establish a good stand of grass quickly. To overcome this, consider increasing seed quantities by up to 50 percent.
- Enhance vegetation establishment by dividing the hydromulch operation into two phases:
 1. Phase 1- Install all seed and fertilizer with 25-30 percent mulch and tackifier onto soil in the first lift.
 2. Phase 2- Install the rest of the mulch and tackifier over the first lift.

Or, enhance vegetation by:

1. Installing the mulch, seed, fertilizer, and tackifier in one lift.
2. Spread or blow straw over the top of the hydromulch at a rate of 800-1000 pounds per acre.
3. Hold straw in place with a standard tackifier.

Both of these approaches will increase cost moderately but will greatly improve and enhance vegetative establishment. The increased cost may be offset by the reduced need for:

- Irrigation.
- Reapplication of mulch.
- Repair of failed slope surfaces.

This technique works with standard hydromulch (1,500 pounds per acre minimum) and BFM/MBFMs (3,000 pounds per acre minimum).

- Seed may be installed by hand if:
 - Temporary and covered by straw, mulch, or topsoil.
 - Permanent in small areas (usually less than 1 acre) and covered with mulch, topsoil, or erosion blankets.
- The seed mixes listed in the tables below include recommended mixes for both temporary and permanent seeding.

- Apply these mixes, with the exception of the wetland mix, at a rate of 120 pounds per acre. This rate can be reduced if soil amendments or slow-release fertilizers are used.
- Consult the local suppliers or the local conservation district for their recommendations because the appropriate mix depends on a variety of factors, including location, exposure, soil type, slope, and expected foot traffic. Alternative seed mixes approved by the local authority may be used.
- Other mixes may be appropriate, depending on the soil type and hydrology of the area.
- [Table 4.1.2](#) lists the standard mix for areas requiring a temporary vegetative cover.

Table 4.1.2 Temporary Erosion Control Seed Mix			
	% Weight	% Purity	% Germination
Chewings or annual blue grass <i>Festuca rubra var. commutata</i> or <i>Poa anna</i>	40	98	90
Perennial rye - <i>Lolium perenne</i>	50	98	90
Redtop or colonial bentgrass <i>Agrostis alba</i> or <i>Agrostis tenuis</i>	5	92	85
White dutch clover <i>Trifolium repens</i>	5	98	90

- [Table 4.1.3](#) lists a recommended mix for landscaping seed.

Table 4.1.3 Landscaping Seed Mix			
	% Weight	% Purity	% Germination
Perennial rye blend <i>Lolium perenne</i>	70	98	90
Chewings and red fescue blend <i>Festuca rubra var. commutata</i> or <i>Festuca rubra</i>	30	98	90

- [Table 4.1.4](#) lists a turf seed mix for dry situations where there is no need for watering. This mix requires very little maintenance.

Table 4.1.4 Low-Growing Turf Seed Mix			
	% Weight	% Purity	% Germination
Dwarf tall fescue (several varieties) <i>Festuca arundinacea</i> var.	45	98	90
Dwarf perennial rye (Barclay) <i>Lolium perenne</i> var. <i>barclay</i>	30	98	90
Red fescue <i>Festuca rubra</i>	20	98	90
Colonial bentgrass <i>Agrostis tenuis</i>	5	98	90

- [Table 4.1.5](#) lists a mix for bioswales and other intermittently wet areas.

Table 4.1.5 Bioswale Seed Mix*			
	% Weight	% Purity	% Germination
Tall or meadow fescue <i>Festuca arundinacea</i> or <i>Festuca elatior</i>	75-80	98	90
Seaside/Creeping bentgrass <i>Agrostis palustris</i>	10-15	92	85
Redtop bentgrass <i>Agrostis alba</i> or <i>Agrostis gigantea</i>	5-10	90	80

* Modified Briargreen, Inc. Hydroseeding Guide Wetlands Seed Mix

- [Table 4.1.6](#) lists a low-growing, relatively non-invasive seed mix appropriate for very wet areas that are not regulated wetlands. Apply this mixture at a rate of 60 pounds per acre. Consult Hydraulic Permit Authority (HPA) for seed mixes if applicable.

Table 4.1.6 Wet Area Seed Mix*			
	% Weight	% Purity	% Germination
Tall or meadow fescue <i>Festuca arundinacea</i> or <i>Festuca elatior</i>	60-70	98	90
Seaside/Creeping bentgrass <i>Agrostis palustris</i>	10-15	98	85
Meadow foxtail <i>Alephocurus pratensis</i>	10-15	90	80
Alsike clover <i>Trifolium hybridum</i>	1-6	98	90
Redtop bentgrass <i>Agrostis alba</i>	1-6	92	85

* Modified Briargreen, Inc. Hydroseeding Guide Wetlands Seed Mix

- Table 4.1.7 lists a recommended meadow seed mix for infrequently maintained areas or non-maintained areas where colonization by native plants is desirable. Likely applications include rural road and utility right-of-way. Seeding should take place in September or very early October in order to obtain adequate establishment prior to the winter months. Consider the appropriateness of clover, a fairly invasive species, in the mix. Amending the soil can reduce the need for clover.

Table 4.1.7 Meadow Seed Mix			
	% Weight	% Purity	% Germination
Redtop or Oregon bentgrass <i>Agrostis alba</i> or <i>Agrostis oregonensis</i>	20	92	85
Red fescue <i>Festuca rubra</i>	70	98	90
White dutch clover <i>Trifolium repens</i>	10	98	90

- **Roughening and Rototilling:**
 - The seedbed should be firm and rough. Roughen all soil no matter what the slope. Track walk slopes before seeding if engineering purposes require compaction. Backblading or smoothing of slopes greater than 4H:1V is not allowed if they are to be seeded.
 - Restoration-based landscape practices require deeper incorporation than that provided by a simple single-pass rototilling treatment. Wherever practical, initially rip the subgrade to improve long-term permeability, infiltration, and water inflow qualities. At a minimum, permanent areas shall use soil amendments to achieve organic matter and permeability performance defined in engineered soil/landscape systems. For systems that are deeper than 8 inches complete the rototilling process in multiple lifts, or prepare the engineered soil system per specifications and place to achieve the specified depth.
- **Fertilizers:**
 - Conducting soil tests to determine the exact type and quantity of fertilizer is recommended. This will prevent the over-application of fertilizer.
 - Organic matter is the most appropriate form of fertilizer because it provides nutrients (including nitrogen, phosphorus, and potassium) in the least water-soluble form.
 - In general, use 10-4-6 N-P-K (nitrogen-phosphorus-potassium) fertilizer at a rate of 90 pounds per acre. Always use slow-release fertilizers because they are more efficient and have fewer environmental impacts. Do not add fertilizer to the hydromulch machine, or agitate, more than 20 minutes before use. Too much agitation destroys the slow-release coating.
 - There are numerous products available that take the place of chemical fertilizers. These include several with seaweed extracts that are beneficial to soil microbes and organisms. If 100 percent cottonseed meal is used as the mulch in hydroseed, chemical fertilizer may not be necessary. Cottonseed meal provides a good source of long-term, slow-release, available nitrogen.
- **Bonded Fiber Matrix and Mechanically Bonded Fiber Matrix:**
 - On steep slopes use Bonded Fiber Matrix (BFM) or Mechanically Bonded Fiber Matrix (MBFM) products. Apply BFM/MBFM products at a minimum rate of 3,000 pounds per acre of mulch with approximately 10 percent tackifier. Achieve a minimum of 95 percent soil coverage during application. Numerous products are available commercially. Installed products per manufacturer's instructions. Most products require 24-36 hours to cure before rainfall and cannot be installed on wet or saturated soils.

Generally, products come in 40-50 pound bags and include all necessary ingredients except for seed and fertilizer.

- BFM and MBFMs provide good alternatives to blankets in most areas requiring vegetation establishment. Advantages over blankets include:
 - BFM and MBFMs do not require surface preparation.
 - Helicopters can assist in installing BFM and MBFMs in remote areas.
 - On slopes steeper than 2.5H:1V, blanket installers may require ropes and harnesses for safety.
 - Installing BFM and MBFMs can save at least \$1,000 per acre compared to blankets.

Maintenance Standards

Reseed any seeded areas that fail to establish at least 80 percent cover (100 percent cover for areas that receive sheet or concentrated flows). If reseeding is ineffective, use an alternate method such as sodding, mulching, or nets/blankets. If winter weather prevents adequate grass growth, this time limit may be relaxed at the discretion of the local authority when sensitive areas would otherwise be protected.

- Reseed and protect by mulch any areas that experience erosion after achieving adequate cover. Reseed and protect by mulch any eroded area.
- Supply seeded areas with adequate moisture, but do not water to the extent that it causes runoff.

Approved as Equivalent

Ecology has approved products as able to meet the requirements of [BMP C120](#). The products did not pass through the Technology Assessment Protocol – Ecology (TAPE) process. Local jurisdictions may choose not to accept this product approved as equivalent, or may require additional testing prior to consideration for local use. The products are available for review on Ecology’s website at

<http://www.ecy.wa.gov/programs/wq/stormwater/newtech/equivalent.html>

BMP C121: Mulching

Purpose

Mulching soils provides immediate temporary protection from erosion. Mulch also enhances plant establishment by conserving moisture, holding fertilizer, seed, and topsoil in place, and moderating soil temperatures. There is an enormous variety of mulches that can be used. This section discusses only the most common types of mulch.

Conditions of Use

As a temporary cover measure, mulch should be used:

- For less than 30 days on disturbed areas that require cover.
- At all times for seeded areas, especially during the wet season and

during the hot summer months.

- During the wet season on slopes steeper than 3H:1V with more than 10 feet of vertical relief.

Mulch may be applied at any time of the year and must be refreshed periodically.

- For seeded areas mulch may be made up of 100 percent: cottonseed meal; fibers made of wood, recycled cellulose, hemp, kenaf; compost; or blends of these. Tackifier shall be plant-based, such as guar or alpha plantago, or chemical-based such as polyacrylamide or polymers. Any mulch or tackifier product used shall be installed per manufacturer's instructions. Generally, mulches come in 40-50 pound bags. Seed and fertilizer are added at time of application.

***Design and
Installation
Specifications***

For mulch materials, application rates, and specifications, see [Table 4.1.8](#). Always use a 2-inch minimum mulch thickness; increase the thickness until the ground is 95% covered (i.e. not visible under the mulch layer). Note: Thickness may be increased for disturbed areas in or near sensitive areas or other areas highly susceptible to erosion.

Mulch used within the ordinary high-water mark of surface waters should be selected to minimize potential flotation of organic matter. Composted organic materials have higher specific gravities (densities) than straw, wood, or chipped material. Consult Hydraulic Permit Authority (HPA) for mulch mixes if applicable.

***Maintenance
Standards***

- The thickness of the cover must be maintained.
- Any areas that experience erosion shall be remulched and/or protected with a net or blanket. If the erosion problem is drainage related, then the problem shall be fixed and the eroded area remulched.

**Table 4.1.8
Mulch Standards and Guidelines**

Mulch Material	Quality Standards	Application Rates	Remarks
Straw	Air-dried; free from undesirable seed and coarse material.	2"-3" thick; 5 bales per 1,000 sf or 2-3 tons per acre	Cost-effective protection when applied with adequate thickness. Hand-application generally requires greater thickness than blown straw. The thickness of straw may be reduced by half when used in conjunction with seeding. In windy areas straw must be held in place by crimping, using a tackifier, or covering with netting. Blown straw always has to be held in place with a tackifier as even light winds will blow it away. Straw, however, has several deficiencies that should be considered when selecting mulch materials. It often introduces and/or encourages the propagation of weed species and it has no significant long-term benefits. It should also not be used within the ordinary high-water elevation of surface waters (due to flotation).
Hydromulch	No growth inhibiting factors.	Approx. 25-30 lbs per 1,000 sf or 1,500 - 2,000 lbs per acre	Shall be applied with hydromulcher. Shall not be used without seed and tackifier unless the application rate is at least doubled. Fibers longer than about ¾-1 inch clog hydromulch equipment. Fibers should be kept to less than ¾ inch.
Composted Mulch and Compost	No visible water or dust during handling. Must be produced in accordance with WAC 173-350 , Solid Waste Handling Standards.	2" thick min.; approx. 100 tons per acre (approx. 800 lbs per yard)	More effective control can be obtained by increasing thickness to 3". Excellent mulch for protecting final grades until landscaping because it can be directly seeded or tilled into soil as an amendment. Composted mulch has a coarser size gradation than compost. It is more stable and practical to use in wet areas and during rainy weather conditions. Do not use composted mulch near wetlands or near phosphorous impaired water bodies.
Chipped Site Vegetation	Average size shall be several inches. Gradations from fines to 6 inches in length for texture, variation, and interlocking properties.	2" thick min.;	This is a cost-effective way to dispose of debris from clearing and grubbing, and it eliminates the problems associated with burning. Generally, it should not be used on slopes above approx. 10% because of its tendency to be transported by runoff. It is not recommended within 200 feet of surface waters. If seeding is expected shortly after mulch, the decomposition of the chipped vegetation may tie up nutrients important to grass establishment.
Wood-based Mulch or Wood Straw	No visible water or dust during handling. Must be purchased from a supplier with a Solid Waste Handling Permit or one exempt from solid waste regulations.	2" thick min.; approx. 100 tons per acre (approx. 800 lbs. per cubic yard)	This material is often called "hog or hogged fuel." The use of mulch ultimately improves the organic matter in the soil. Special caution is advised regarding the source and composition of wood-based mulches. Its preparation typically does not provide any weed seed control, so evidence of residual vegetation in its composition or known inclusion of weed plants or seeds should be monitored and prevented (or minimized).
Wood Strand Mulch	A blend of loose, long, thin wood pieces derived from native conifer or deciduous trees with high length-to-width ratio.	2" thick min.	Cost-effective protection when applied with adequate thickness. A minimum of 95-percent of the wood strand shall have lengths between 2 and 10-inches, with a width and thickness between 1/16 and ¾-inches. The mulch shall not contain resin, tannin, or other compounds in quantities that would be detrimental to plant life. Sawdust or wood shavings shall not be used as mulch. (WSDOT specification (9-14.4(4)))

BMP C122: Nets and Blankets

Purpose

Erosion control nets and blankets are intended to prevent erosion and hold seed and mulch in place on steep slopes and in channels so that vegetation can become well established. In addition, some nets and blankets can be used to permanently reinforce turf to protect drainage ways during high flows. Nets (commonly called matting) are strands of material woven into an open, but high-tensile strength net (for example, coconut fiber matting). Blankets are strands of material that are not tightly woven, but instead form a layer of interlocking fibers, typically held together by a biodegradable or photodegradable netting (for example, excelsior or straw blankets). They generally have lower tensile strength than nets, but cover the ground more completely. Coir (coconut fiber) fabric comes as both nets and blankets.

Conditions of Use

Erosion control nets and blankets should be used:

- To aid permanent vegetated stabilization of slopes 2H:1V or greater and with more than 10 feet of vertical relief.
- For drainage ditches and swales (highly recommended). The application of appropriate netting or blanket to drainage ditches and swales can protect bare soil from channelized runoff while vegetation is established. Nets and blankets also can capture a great deal of sediment due to their open, porous structure. Nets and blankets can be used to permanently stabilize channels and may provide a cost-effective, environmentally preferable alternative to riprap. 100 percent synthetic blankets manufactured for use in ditches may be easily reused as temporary ditch liners.

Disadvantages of blankets include:

- Surface preparation required.
- On slopes steeper than 2.5H:1V, blanket installers may need to be roped and harnessed for safety.
- They cost at least \$4,000-6,000 per acre installed.

Advantages of blankets include:

- Installation without mobilizing special equipment.
- Installation by anyone with minimal training
- Installation in stages or phases as the project progresses.
- Installers can hand place seed and fertilizer as they progress down the slope.
- Installation in any weather.
- There are numerous types of blankets that can be designed with various parameters in mind. Those parameters include: fiber blend, mesh strength, longevity, biodegradability, cost, and availability.

*Design and
Installation
Specifications*

- See [Figure 4.1.3](#) and [Figure 4.1.4](#) for typical orientation and installation of blankets used in channels and as slope protection. Note: these are typical only; all blankets must be installed per manufacturer's installation instructions.
- Installation is critical to the effectiveness of these products. If good ground contact is not achieved, runoff can concentrate under the product, resulting in significant erosion.
- Installation of Blankets on Slopes:
 1. Complete final grade and track walk up and down the slope.
 2. Install hydromulch with seed and fertilizer.
 3. Dig a small trench, approximately 12 inches wide by 6 inches deep along the top of the slope.
 4. Install the leading edge of the blanket into the small trench and staple approximately every 18 inches. NOTE: Staples are metal, "U"-shaped, and a minimum of 6 inches long. Longer staples are used in sandy soils. Biodegradable stakes are also available.
 5. Roll the blanket slowly down the slope as installer walks backwards. NOTE: The blanket rests against the installer's legs. Staples are installed as the blanket is unrolled. It is critical that the proper staple pattern is used for the blanket being installed. The blanket is not to be allowed to roll down the slope on its own as this stretches the blanket making it impossible to maintain soil contact. In addition, no one is allowed to walk on the blanket after it is in place.
 6. If the blanket is not long enough to cover the entire slope length, the trailing edge of the upper blanket should overlap the leading edge of the lower blanket and be stapled. On steeper slopes, this overlap should be installed in a small trench, stapled, and covered with soil.
- With the variety of products available, it is impossible to cover all the details of appropriate use and installation. Therefore, it is critical that the design engineer consult the manufacturer's information and that a site visit takes place in order to ensure that the product specified is appropriate. Information is also available at the following web sites:
 1. WSDOT (Section 3.2.4):
<http://www.wsdot.wa.gov/NR/rdonlyres/3B41E087-FA86-4717-932D-D7A8556CCD57/0/ErosionTrainingManual.pdf>
 2. Texas Transportation Institute:
http://www.txdot.gov/business/doing_business/product_evaluation/erosion_control.htm

- Use jute matting in conjunction with mulch ([BMP C121](#)). Excelsior, woven straw blankets and coir (coconut fiber) blankets may be installed without mulch. There are many other types of erosion control nets and blankets on the market that may be appropriate in certain circumstances.
 - In general, most nets (e.g., jute matting) require mulch in order to prevent erosion because they have a fairly open structure. Blankets typically do not require mulch because they usually provide complete protection of the surface.
 - Extremely steep, unstable, wet, or rocky slopes are often appropriate candidates for use of synthetic blankets, as are riverbanks, beaches and other high-energy environments. If synthetic blankets are used, the soil should be hydromulched first.
 - 100-percent biodegradable blankets are available for use in sensitive areas. These organic blankets are usually held together with a paper or fiber mesh and stitching which may last up to a year.
 - Most netting used with blankets is photodegradable, meaning they break down under sunlight (not UV stabilized). However, this process can take months or years even under bright sun. Once vegetation is established, sunlight does not reach the mesh. It is not uncommon to find non-degraded netting still in place several years after installation. This can be a problem if maintenance requires the use of mowers or ditch cleaning equipment. In addition, birds and small animals can become trapped in the netting.
- Maintenance Standards***
- Maintain good contact with the ground. Erosion must not occur beneath the net or blanket.
 - Repair and staple any areas of the net or blanket that are damaged or not in close contact with the ground.
 - Fix and protect eroded areas if erosion occurs due to poorly controlled drainage.

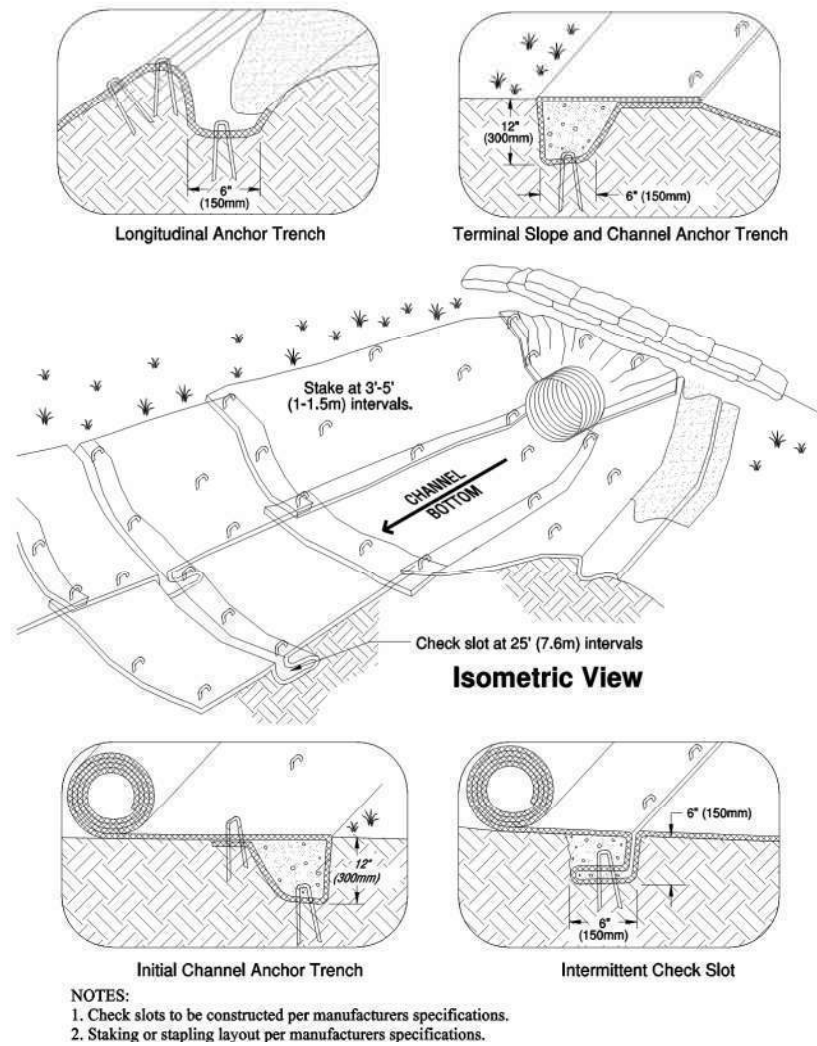

Figure 4.1.3 – Channel Installation

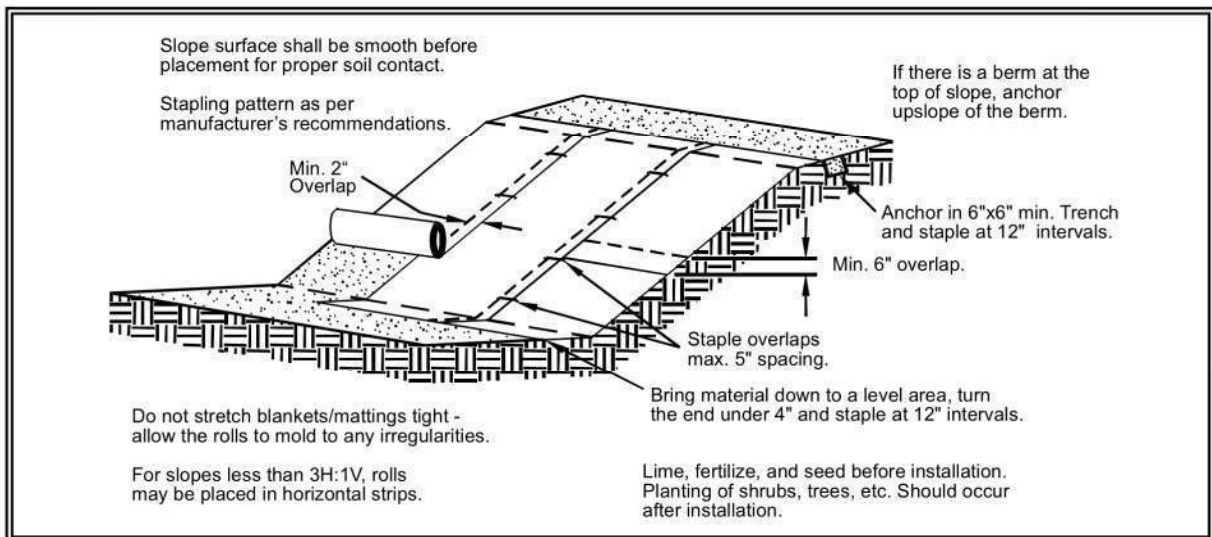

Figure 4.1.4 – Slope Installation

BMP C123: Plastic Covering

Purpose

Plastic covering provides immediate, short-term erosion protection to slopes and disturbed areas.

Conditions of Use

Plastic covering may be used on disturbed areas that require cover measures for less than 30 days, except as stated below.

- Plastic is particularly useful for protecting cut and fill slopes and stockpiles. Note: The relatively rapid breakdown of most polyethylene sheeting makes it unsuitable for long-term (greater than six months) applications.
- Due to rapid runoff caused by plastic covering, do not use this method upslope of areas that might be adversely impacted by concentrated runoff. Such areas include steep and/or unstable slopes.
- Plastic sheeting may result in increased runoff volumes and velocities, requiring additional on-site measures to counteract the increases. Creating a trough with wattles or other material can convey clean water away from these areas.
- To prevent undercutting, trench and backfill rolled plastic covering products.
- While plastic is inexpensive to purchase, the added cost of installation, maintenance, removal, and disposal make this an expensive material, up to \$1.50-2.00 per square yard.
- Whenever plastic is used to protect slopes install water collection measures at the base of the slope. These measures include plastic-covered berms, channels, and pipes used to convey clean rainwater away from bare soil and disturbed areas. Do not mix clean runoff from a plastic covered slope with dirty runoff from a project.
- Other uses for plastic include:
 1. Temporary ditch liner.
 2. Pond liner in temporary sediment pond.
 3. Liner for bermed temporary fuel storage area if plastic is not reactive to the type of fuel being stored.
 4. Emergency slope protection during heavy rains.
 5. Temporary drainpipe (“elephant trunk”) used to direct water.
- Plastic slope cover must be installed as follows:
 1. Run plastic up and down slope, not across slope.
 2. Plastic may be installed perpendicular to a slope if the slope length is less than 10 feet.
 3. Minimum of 8-inch overlap at seams.

Design and Installation Specifications

4. On long or wide slopes, or slopes subject to wind, tape all seams.
 5. Place plastic into a small (12-inch wide by 6-inch deep) slot trench at the top of the slope and backfill with soil to keep water from flowing underneath.
 6. Place sand filled burlap or geotextile bags every 3 to 6 feet along seams and tie them together with twine to hold them in place.
 7. Inspect plastic for rips, tears, and open seams regularly and repair immediately. This prevents high velocity runoff from contacting bare soil which causes extreme erosion.
 8. Sandbags may be lowered into place tied to ropes. However, all sandbags must be staked in place.
- Plastic sheeting shall have a minimum thickness of 0.06 millimeters.
 - If erosion at the toe of a slope is likely, a gravel berm, riprap, or other suitable protection shall be installed at the toe of the slope in order to reduce the velocity of runoff.
 - Torn sheets must be replaced and open seams repaired.
 - Completely remove and replace the plastic if it begins to deteriorate due to ultraviolet radiation.
 - Completely remove plastic when no longer needed.
 - Dispose of old tires used to weight down plastic sheeting appropriately.

Maintenance Standards

Approved as Equivalent

Ecology has approved products as able to meet the requirements of [BMP C123](#). The products did not pass through the Technology Assessment Protocol – Ecology (TAPE) process. Local jurisdictions may choose not to accept this product approved as equivalent, or may require additional testing prior to consideration for local use. The products are available for review on Ecology’s website at <http://www.ecy.wa.gov/programs/wq/stormwater/newtech/equivalent.html>

BMP C124: Sodding

Purpose

The purpose of sodding is to establish permanent turf for immediate erosion protection and to stabilize drainage ways where concentrated overland flow will occur.

Conditions of Use

Sodding may be used in the following areas:

- Disturbed areas that require short-term or long-term cover.
- Disturbed areas that require immediate vegetative cover.
- All waterways that require vegetative lining. Waterways may also be seeded rather than sodded, and protected with a net or blanket.

BMP C140: Dust Control

Purpose

Dust control prevents wind transport of dust from disturbed soil surfaces onto roadways, drainage ways, and surface waters.

Conditions of Use

- In areas (including roadways) subject to surface and air movement of dust where on-site and off-site impacts to roadways, drainage ways, or surface waters are likely.

Design and Installation Specifications

- Vegetate or mulch areas that will not receive vehicle traffic. In areas where planting, mulching, or paving is impractical, apply gravel or landscaping rock.
- Limit dust generation by clearing only those areas where immediate activity will take place, leaving the remaining area(s) in the original condition. Maintain the original ground cover as long as practical.
- Construct natural or artificial windbreaks or windscreens. These may be designed as enclosures for small dust sources.
- Sprinkle the site with water until surface is wet. Repeat as needed. To prevent carryout of mud onto street, refer to Stabilized Construction Entrance ([BMP C105](#)).
- Irrigation water can be used for dust control. Irrigation systems should be installed as a first step on sites where dust control is a concern.
- Spray exposed soil areas with a dust palliative, following the manufacturer's instructions and cautions regarding handling and application. Used oil is prohibited from use as a dust suppressant. Local governments may approve other dust palliatives such as calcium chloride or PAM.
- PAM ([BMP C126](#)) added to water at a rate of 0.5 lbs. per 1,000 gallons of water per acre and applied from a water truck is more effective than water alone. This is due to increased infiltration of water into the soil and reduced evaporation. In addition, small soil particles are bonded together and are not as easily transported by wind. Adding PAM may actually reduce the quantity of water needed for dust control. Use of PAM could be a cost-effective dust control method.

Techniques that can be used for unpaved roads and lots include:

- Lower speed limits. High vehicle speed increases the amount of dust stirred up from unpaved roads and lots.
- Upgrade the road surface strength by improving particle size, shape, and mineral types that make up the surface and base materials.
- Add surface gravel to reduce the source of dust emission. Limit the amount of fine particles (those smaller than .075 mm) to 10 to 20 percent.

- Use geotextile fabrics to increase the strength of new roads or roads undergoing reconstruction.
- Encourage the use of alternate, paved routes, if available.
- Restrict use of paved roadways by tracked vehicles and heavy trucks to prevent damage to road surface and base.
- Apply chemical dust suppressants using the admix method, blending the product with the top few inches of surface material. Suppressants may also be applied as surface treatments.
- Pave unpaved permanent roads and other trafficked areas.
- Use vacuum street sweepers.
- Remove mud and other dirt promptly so it does not dry and then turn into dust.
- Limit dust-causing work on windy days.
- Contact your local Air Pollution Control Authority for guidance and training on other dust control measures. Compliance with the local Air Pollution Control Authority constitutes compliance with this BMP.

Maintenance Standards

Respray area as necessary to keep dust to a minimum.

BMP C150: Materials on Hand

Purpose

Keep quantities of erosion prevention and sediment control materials on the project site at all times to be used for regular maintenance and emergency situations such as unexpected heavy summer rains. Having these materials on-site reduces the time needed to implement BMPs when inspections indicate that existing BMPs are not meeting the Construction SWPPP requirements. In addition, contractors can save money by buying some materials in bulk and storing them at their office or yard.

Conditions of Use

- Construction projects of any size or type can benefit from having materials on hand. A small commercial development project could have a roll of plastic and some gravel available for immediate protection of bare soil and temporary berm construction. A large earthwork project, such as highway construction, might have several tons of straw, several rolls of plastic, flexible pipe, sandbags, geotextile fabric and steel “T” posts.
- Materials are stockpiled and readily available before any site clearing, grubbing, or earthwork begins. A large contractor or developer could keep a stockpile of materials that are available for use on several projects.
- If storage space at the project site is at a premium, the contractor could maintain the materials at their office or yard. The office or yard must be less than an hour from the project site.

Design and Installation Specifications

Depending on project type, size, complexity, and length, materials and quantities will vary. A good minimum list of items that will cover numerous situations includes:

Material
Clear Plastic, 6 mil
Drainpipe, 6 or 8 inch diameter
Sandbags, filled
Straw Bales for mulching,
Quarry Spalls
Washed Gravel
Geotextile Fabric
Catch Basin Inserts
Steel "T" Posts
Silt fence material
Straw Wattles

Maintenance Standards

- All materials with the exception of the quarry spalls, steel "T" posts, and gravel should be kept covered and out of both sun and rain.
- Re-stock materials used as needed.

BMP C151: Concrete Handling

Purpose

Concrete work can generate process water and slurry that contain fine particles and high pH, both of which can violate water quality standards in the receiving water. Concrete spillage or concrete discharge to surface waters of the State is prohibited. Use this BMP to minimize and eliminate concrete, concrete process water, and concrete slurry from entering waters of the state.

Conditions of Use

Any time concrete is used, utilize these management practices. Concrete construction projects include, but are not limited to, the following:

- Curbs
- Sidewalks
- Roads
- Bridges
- Foundations
- Floors
- Runways

Design and Installation

- Wash out concrete truck chutes, pumps, and internals into formed areas only. Assure that washout of concrete trucks is performed off-

Specifications

site or in designated concrete washout areas. Do not wash out concrete trucks onto the ground, or into storm drains, open ditches, streets, or streams. Refer to [BMP C154](#) for information on concrete washout areas.

- Return unused concrete remaining in the truck and pump to the originating batch plant for recycling. Do not dump excess concrete on site, except in designated concrete washout areas.
- Wash off hand tools including, but not limited to, screeds, shovels, rakes, floats, and trowels into formed areas only.
- Wash equipment difficult to move, such as concrete pavers in areas that do not directly drain to natural or constructed stormwater conveyances.
- Do not allow washdown from areas, such as concrete aggregate driveways, to drain directly to natural or constructed stormwater conveyances.
- Contain washwater and leftover product in a lined container when no formed areas are available,. Dispose of contained concrete in a manner that does not violate ground water or surface water quality standards.
- Always use forms or solid barriers for concrete pours, such as pilings, within 15-feet of surface waters.
- Refer to [BMPs C252](#) and [C253](#) for pH adjustment requirements.
- Refer to the Construction Stormwater General Permit for pH monitoring requirements if the project involves one of the following activities:
 - Significant concrete work (greater than 1,000 cubic yards poured concrete or recycled concrete used over the life of a project).
 - The use of engineered soils amended with (but not limited to) Portland cement-treated base, cement kiln dust or fly ash.
 - Discharging stormwater to segments of water bodies on the 303(d) list (Category 5) for high pH.

Maintenance Standards

Check containers for holes in the liner daily during concrete pours and repair the same day.

BMP C152: Sawcutting and Surfacing Pollution Prevention

Purpose Sawcutting and surfacing operations generate slurry and process water that contains fine particles and high pH (concrete cutting), both of which can violate the water quality standards in the receiving water. Concrete spillage or concrete discharge to surface waters of the State is prohibited. Use this BMP to minimize and eliminate process water and slurry created through sawcutting or surfacing from entering waters of the State.

Conditions of Use Utilize these management practices anytime sawcutting or surfacing operations take place. Sawcutting and surfacing operations include, but are not limited to, the following:

- Sawing
- Coring
- Grinding
- Roughening
- Hydro-demolition
- Bridge and road surfacing
- Vacuum slurry and cuttings during cutting and surfacing operations.
- Slurry and cuttings shall not remain on permanent concrete or asphalt pavement overnight.
- Slurry and cuttings shall not drain to any natural or constructed drainage conveyance including stormwater systems. This may require temporarily blocking catch basins.
- Dispose of collected slurry and cuttings in a manner that does not violate ground water or surface water quality standards.
- Do not allow process water generated during hydro-demolition, surface roughening or similar operations to drain to any natural or constructed drainage conveyance including stormwater systems. Dispose process water in a manner that does not violate ground water or surface water quality standards.
- Handle and dispose cleaning waste material and demolition debris in a manner that does not cause contamination of water. Dispose of sweeping material from a pick-up sweeper at an appropriate disposal site.

Maintenance Standards Continually monitor operations to determine whether slurry, cuttings, or process water could enter waters of the state. If inspections show that a violation of water quality standards could occur, stop operations and immediately implement preventive measures such as berms, barriers, secondary containment, and vacuum trucks.

BMP C200: Interceptor Dike and Swale

Purpose Provide a ridge of compacted soil, or a ridge with an upslope swale, at the top or base of a disturbed slope or along the perimeter of a disturbed construction area to convey stormwater. Use the dike and/or swale to intercept the runoff from unprotected areas and direct it to areas where erosion can be controlled. This can prevent storm runoff from entering the work area or sediment-laden runoff from leaving the construction site.

Conditions of Use Where the runoff from an exposed site or disturbed slope must be conveyed to an erosion control facility which can safely convey the stormwater.

***Design and
Installation
Specifications***

- Locate upslope of a construction site to prevent runoff from entering disturbed area.
- When placed horizontally across a disturbed slope, it reduces the amount and velocity of runoff flowing down the slope.
- Locate downslope to collect runoff from a disturbed area and direct water to a sediment basin.
- Dike and/or swale and channel must be stabilized with temporary or permanent vegetation or other channel protection during construction.
- Channel requires a positive grade for drainage; steeper grades require channel protection and check dams.
- Review construction for areas where overtopping may occur.
- Can be used at top of new fill before vegetation is established.
- May be used as a permanent diversion channel to carry the runoff.
- Sub-basin tributary area should be one acre or less.
- Design capacity for the peak flow from a 10-year, 24-hour storm, assuming a Type 1A rainfall distribution, for temporary facilities. Alternatively, use 1.6 times the 10-year, 1-hour flow indicated by an approved continuous runoff model. For facilities that will also serve on a permanent basis, consult the local government's drainage requirements.

Interceptor dikes shall meet the following criteria:

Top Width	2 feet minimum.
Height	1.5 feet minimum on berm.
Side Slope	2H:1V or flatter.
Grade	Depends on topography, however, dike system minimum is 0.5%, and maximum is 1%.
Compaction	Minimum of 90 percent ASTM D698 standard proctor.

Horizontal Spacing of Interceptor Dikes:

Average Slope	Slope Percent	Flowpath Length
20H:1V or less	3-5%	300 feet
(10 to 20)H:1V	5-10%	200 feet
(4 to 10)H:1V	10-25%	100 feet
(2 to 4)H:1V	25-50%	50 feet

Stabilization depends on velocity and reach

Slopes <5% Seed and mulch applied within 5 days of dike construction (see [BMP C121, Mulching](#)).

Slopes 5 - 40% Dependent on runoff velocities and dike materials. Stabilization should be done immediately using either sod or riprap or other measures to avoid erosion.

- The upslope side of the dike shall provide positive drainage to the dike outlet. No erosion shall occur at the outlet. Provide energy dissipation measures as necessary. Sediment-laden runoff must be released through a sediment trapping facility.
- Minimize construction traffic over temporary dikes. Use temporary cross culverts for channel crossing.

Interceptor swales shall meet the following criteria:

Bottom Width 2 feet minimum; the cross-section bottom shall be level.

Depth 1-foot minimum.

Side Slope 2H:1V or flatter.

Grade Maximum 5 percent, with positive drainage to a suitable outlet (such as a sediment pond).

Stabilization Seed as per [BMP C120, Temporary and Permanent Seeding](#), or [BMP C202, Channel Lining](#), 12 inches thick riprap pressed into the bank and extending at least 8 inches vertical from the bottom.

- Inspect diversion dikes and interceptor swales once a week and after every rainfall. Immediately remove sediment from the flow area.
- Damage caused by construction traffic or other activity must be repaired before the end of each working day.

Check outlets and make timely repairs as needed to avoid gully formation. When the area below the temporary diversion dike is permanently stabilized, remove the dike and fill and stabilize the channel to blend with the natural surface.

BMP C201: Grass-Lined Channels

<i>Purpose</i>	To provide a channel with a vegetative lining for conveyance of runoff. See Figure 4.2.1 for typical grass-lined channels.
<i>Conditions of Use</i>	<p>This practice applies to construction sites where concentrated runoff needs to be contained to prevent erosion or flooding.</p> <ul style="list-style-type: none">• When a vegetative lining can provide sufficient stability for the channel cross section and at lower velocities of water (normally dependent on grade). This means that the channel slopes are generally less than 5 percent and space is available for a relatively large cross section.• Typical uses include roadside ditches, channels at property boundaries, outlets for diversions, and other channels and drainage ditches in low areas.• Channels that will be vegetated should be installed before major earthwork and hydroseeded with a bonded fiber matrix (BFM). The vegetation should be well established (i.e., 75 percent cover) before water is allowed to flow in the ditch. With channels that will have high flows, erosion control blankets should be installed over the hydroseed. If vegetation cannot be established from seed before water is allowed in the ditch, sod should be installed in the bottom of the ditch in lieu of hydromulch and blankets.
<i>Design and Installation Specifications</i>	<p>Locate the channel where it can conform to the topography and other features such as roads.</p> <ul style="list-style-type: none">• Locate them to use natural drainage systems to the greatest extent possible.• Avoid sharp changes in alignment or bends and changes in grade.• Do not reshape the landscape to fit the drainage channel.• The maximum design velocity shall be based on soil conditions, type of vegetation, and method of revegetation, but at no times shall velocity exceed 5 feet/second. The channel shall not be overtopped by the peak runoff from a 10-year, 24-hour storm, assuming a Type 1A rainfall distribution." Alternatively, use 1.6 times the 10-year, 1-hour flow indicated by an approved continuous runoff model to determine a flow rate which the channel must contain.• Where the grass-lined channel will also function as a permanent stormwater conveyance facility, consult the drainage conveyance requirements of the local government with jurisdiction.

- An established grass or vegetated lining is required before the channel can be used to convey stormwater, unless stabilized with nets or blankets.
- If design velocity of a channel to be vegetated by seeding exceeds 2 ft/sec, a temporary channel liner is required. Geotextile or special mulch protection such as fiberglass roving or straw and netting provides stability until the vegetation is fully established. See [Figure 4.2.2](#).
- Check dams shall be removed when the grass has matured sufficiently to protect the ditch or swale unless the slope of the swale is greater than 4 percent. The area beneath the check dams shall be seeded and mulched immediately after dam removal.
- If vegetation is established by sodding, the permissible velocity for established vegetation may be used and no temporary liner is needed.
- Do not subject grass-lined channel to sedimentation from disturbed areas. Use sediment-trapping BMPs upstream of the channel.
- V-shaped grass channels generally apply where the quantity of water is small, such as in short reaches along roadsides. The V-shaped cross section is least desirable because it is difficult to stabilize the bottom where velocities may be high.
- Trapezoidal grass channels are used where runoff volumes are large and slope is low so that velocities are nonerosive to vegetated linings. (Note: it is difficult to construct small parabolic shaped channels.)
- Subsurface drainage, or riprap channel bottoms, may be necessary on sites that are subject to prolonged wet conditions due to long duration flows or a high water table.
- Provide outlet protection at culvert ends and at channel intersections.
- Grass channels, at a minimum, should carry peak runoff for temporary construction drainage facilities from the 10-year, 24-hour storm without eroding. Where flood hazard exists, increase the capacity according to the potential damage.
- Grassed channel side slopes generally are constructed 3H:1V or flatter to aid in the establishment of vegetation and for maintenance.
- Construct channels a minimum of 0.2 foot larger around the periphery to allow for soil bulking during seedbed preparations and sod buildup.

Maintenance Standards

During the establishment period, check grass-lined channels after every rainfall.

- After grass is established, periodically check the channel; check it after every heavy rainfall event. Immediately make repairs.
- It is particularly important to check the channel outlet and all road crossings for bank stability and evidence of piping or scour holes.

- Remove all significant sediment accumulations to maintain the designed carrying capacity. Keep the grass in a healthy, vigorous condition at all times, since it is the primary erosion protection for the channel.

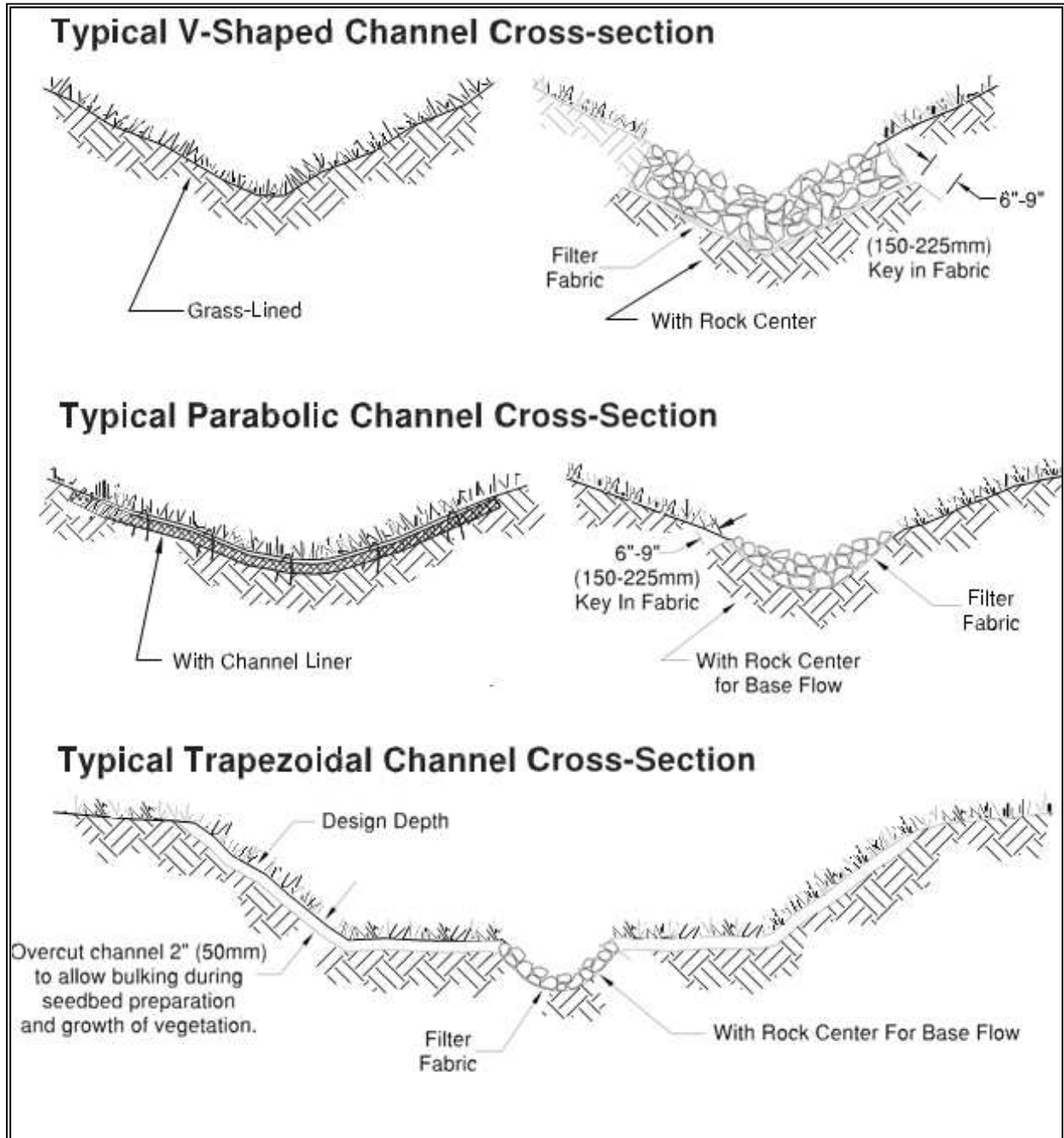
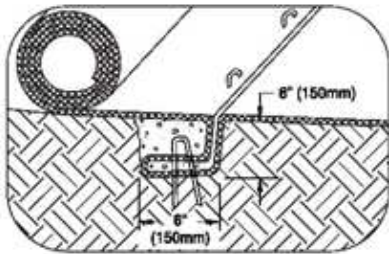
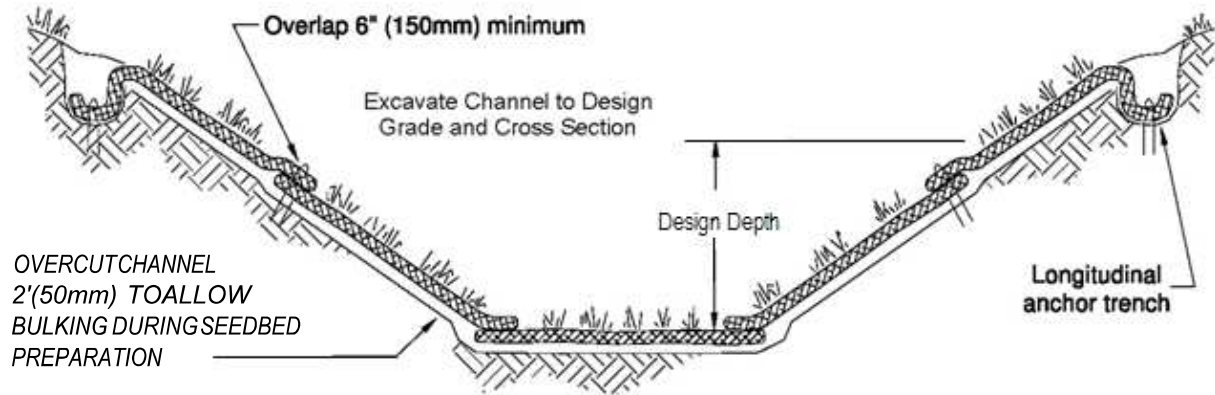
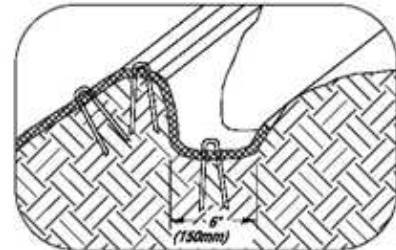

Figure 4.2.1 – Typical Grass-Lined Channels



Intermittent Check Slot

TYPICAL INSTALLATION WITH EROSION CONTROL BLANKETS OR TURF REINFORCEMENT MATS



Longitudinal Anchor Trench

Shingle-lap spliced ends or begin new roll in an intermittent check slot

Prepare soil and apply seed before installing blankets, mats or other temporary channel liner system

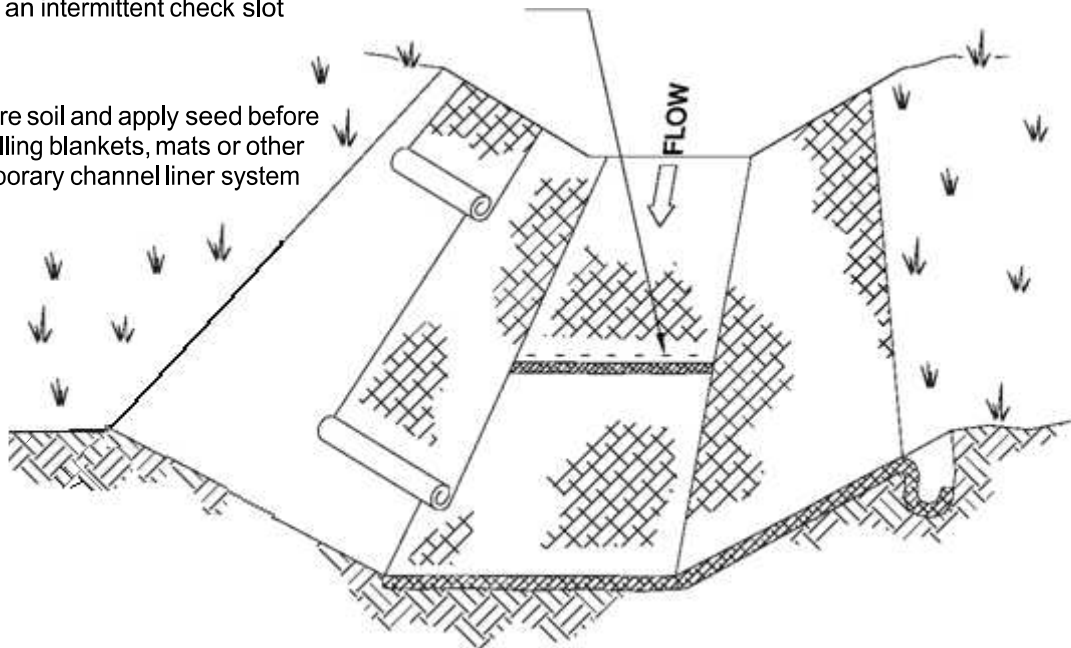

NOTES:

- 1 Design velocities exceeding 2 ft/sec (0.5m/sec) require temporary blankets, mats or similar liners to protect seed and soil until vegetation becomes established.
- 2 Grass-lined channels with design velocities exceeding 6 ft/sec (2m/sec) should include turf reinforcement mats.

Figure 4.2.2 – Temporary Channel Liners

BMP C202: Channel Lining

Purpose

To protect channels by providing a channel liner using either blankets or riprap.

Conditions of Use

When natural soils or vegetated stabilized soils in a channel are not adequate to prevent channel erosion.

- When a permanent ditch or pipe system is to be installed and a temporary measure is needed.
- In almost all cases, synthetic and organic coconut blankets are more effective than riprap for protecting channels from erosion. Blankets can be used with and without vegetation. Blanketed channels can be designed to handle any expected flow and longevity requirement. Some synthetic blankets have a predicted life span of 50 years or more, even in sunlight.
- Other reasons why blankets are better than rock include the availability of blankets over rock. In many areas of the state, rock is not easily obtainable or is very expensive to haul to a site. Blankets can be delivered anywhere. Rock requires the use of dump trucks to haul and heavy equipment to place. Blankets usually only require laborers with hand tools, and sometimes a backhoe.
- The Federal Highway Administration recommends not using flexible liners whenever the slope exceeds 10 percent or the shear stress exceeds 8 lbs/ft².

Design and Installation Specifications

See [BMP C122](#) for information on blankets.

Since riprap is used where erosion potential is high, construction must be sequenced so that the riprap is put in place with the minimum possible delay.

- Disturbance of areas where riprap is to be placed should be undertaken only when final preparation and placement of the riprap can follow immediately behind the initial disturbance. Where riprap is used for outlet protection, the riprap should be placed before or in conjunction with the construction of the pipe or channel so that it is in place when the pipe or channel begins to operate.
- The designer, after determining the riprap size that will be stable under the flow conditions, shall consider that size to be a minimum size and then, based on riprap gradations actually available in the area, select the size or sizes that equal or exceed the minimum size. The possibility of drainage structure damage by children shall be considered in selecting a riprap size, especially if there is nearby water or a gully in which to toss the stones.
- Stone for riprap shall consist of field stone or quarry stone of approximately rectangular shape. The stone shall be hard and angular

and of such quality that it will not disintegrate on exposure to water or weathering and it shall be suitable in all respects for the purpose intended.

- A lining of engineering filter fabric (geotextile) shall be placed between the riprap and the underlying soil surface to prevent soil movement into or through the riprap. The geotextile should be keyed in at the top of the bank.
- Filter fabric shall not be used on slopes greater than 1-1/2H:1V as slippage may occur. It should be used in conjunction with a layer of coarse aggregate (granular filter blanket) when the riprap to be placed is 12 inches and larger.

BMP C203: Water Bars

Purpose

A small ditch or ridge of material is constructed diagonally across a road or right-of-way to divert stormwater runoff from the road surface, wheel tracks, or a shallow road ditch. See [Figure 4.2.3](#).

Conditions of use

Clearing right-of-way and construction of access for power lines, pipelines, and other similar installations often require long narrow right-of-ways over sloping terrain. Disturbance and compaction promotes gully formation in these cleared strips by increasing the volume and velocity of runoff. Gully formation may be especially severe in tire tracks and ruts. To prevent gulying, runoff can often be diverted across the width of the right-of-way to undisturbed areas by using small predesigned diversions.

- Give special consideration to each individual outlet area, as well as to the cumulative effect of added diversions. Use gravel to stabilize the diversion where significant vehicular traffic is anticipated.

Design and Installation Specifications

Height: 8-inch minimum measured from the channel bottom to the ridge top.

- Side slope of channel: 2H:1V maximum; 3H:1V or flatter when vehicles will cross.
- Base width of ridge: 6-inch minimum.
- Locate them to use natural drainage systems and to discharge into well vegetated stable areas.
- Guideline for Spacing:

Slope %	Spacing (ft)
< 5	125
5 - 10	100
10 - 20	75
20 - 35	50
> 35	Use rock lined ditch

BMP C204: Pipe Slope Drains

Purpose To use a pipe to convey stormwater anytime water needs to be diverted away from or over bare soil to prevent gullies, channel erosion, and saturation of slide-prone soils.

Conditions of Use Pipe slope drains should be used when a temporary or permanent stormwater conveyance is needed to move the water down a steep slope to avoid erosion ([Figure 4.2.4](#)).

On highway projects, pipe slope drains should be used at bridge ends to collect runoff and pipe it to the base of the fill slopes along bridge approaches. These can be designed into a project and included as bid items. Another use on road projects is to collect runoff from pavement and pipe it away from side slopes. These are useful because there is generally a time lag between having the first lift of asphalt installed and the curbs, gutters, and permanent drainage installed. Used in conjunction with sand bags, or other temporary diversion devices, these will prevent massive amounts of sediment from leaving a project.

Water can be collected, channeled with sand bags, Triangular Silt Dikes, berms, or other material, and piped to temporary sediment ponds.

Pipe slope drains can be:

- Connected to new catch basins and used temporarily until all permanent piping is installed;
- Used to drain water collected from aquifers exposed on cut slopes and take it to the base of the slope;
- Used to collect clean runoff from plastic sheeting and direct it away from exposed soil;
- Installed in conjunction with silt fence to drain collected water to a controlled area;
- Used to divert small seasonal streams away from construction. They have been used successfully on culvert replacement and extension jobs. Large flex pipe can be used on larger streams during culvert removal, repair, or replacement; and,
- Connected to existing down spouts and roof drains and used to divert water away from work areas during building renovation, demolition, and construction projects.

There are now several commercially available collectors that are attached to the pipe inlet and help prevent erosion at the inlet.

***Design and
Installation
Specifications***

Size the pipe to convey the flow. The capacity for temporary drains shall be sufficient to handle the peak flow from a 10-year, 24-hour storm event, assuming a Type 1A rainfall distribution. Alternatively, use 1.6 times the 10-year, 1-hour flow indicated by an approved continuous runoff model.

Consult local drainage requirements for sizing permanent pipe slope drains.

- Use care in clearing vegetated slopes for installation.
- Re-establish cover immediately on areas disturbed by installation.
- Use temporary drains on new cut or fill slopes.
- Use diversion dikes or swales to collect water at the top of the slope.
- Ensure that the entrance area is stable and large enough to direct flow into the pipe.
- Piping of water through the berm at the entrance area is a common failure mode.
- The entrance shall consist of a standard flared end section for culverts 12 inches and larger with a minimum 6-inch metal toe plate to prevent runoff from undercutting the pipe inlet. The slope of the entrance shall be at least 3 percent. Sand bags may also be used at pipe entrances as a temporary measure.
- The soil around and under the pipe and entrance section shall be thoroughly compacted to prevent undercutting.
- The flared inlet section shall be securely connected to the slope drain and have watertight connecting bands.
- Slope drain sections shall be securely fastened together, fused or have gasketed watertight fittings, and shall be securely anchored into the soil.
- Thrust blocks should be installed anytime 90 degree bends are utilized. Depending on size of pipe and flow, these can be constructed with sand bags, straw bales staked in place, “t” posts and wire, or ecology blocks.
- Pipe needs to be secured along its full length to prevent movement. This can be done with steel “t” posts and wire. A post is installed on each side of the pipe and the pipe is wired to them. This should be done every 10-20 feet of pipe length or so, depending on the size of the pipe and quantity of water to divert.
- Interceptor dikes shall be used to direct runoff into a slope drain. The height of the dike shall be at least 1 foot higher at all points than the top of the inlet pipe.
- The area below the outlet must be stabilized with a riprap apron (see [BMP C209](#) Outlet Protection, for the appropriate outlet material).

- If the pipe slope drain is conveying sediment-laden water, direct all flows into the sediment trapping facility.
- Materials specifications for any permanent piped system shall be set by the local government.

Maintenance Standards

Check inlet and outlet points regularly, especially after storms.

The inlet should be free of undercutting, and no water should be going around the point of entry. If there are problems, the headwall should be reinforced with compacted earth or sand bags.

- The outlet point should be free of erosion and installed with appropriate outlet protection.
- For permanent installations, inspect pipe periodically for vandalism and physical distress such as slides and wind-throw.
- Normally the pipe slope is so steep that clogging is not a problem with smooth wall pipe, however, debris may become lodged in the pipe.

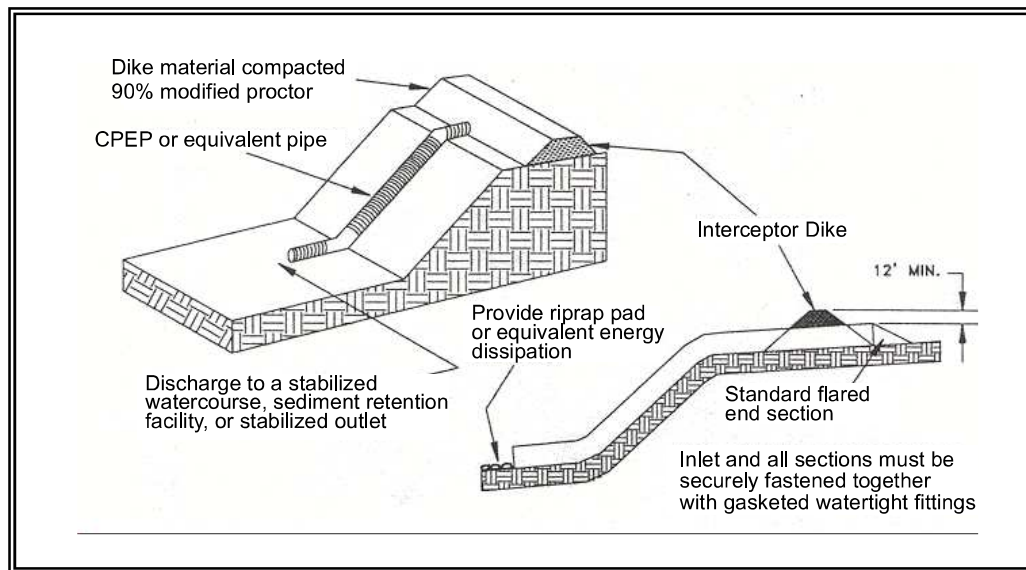
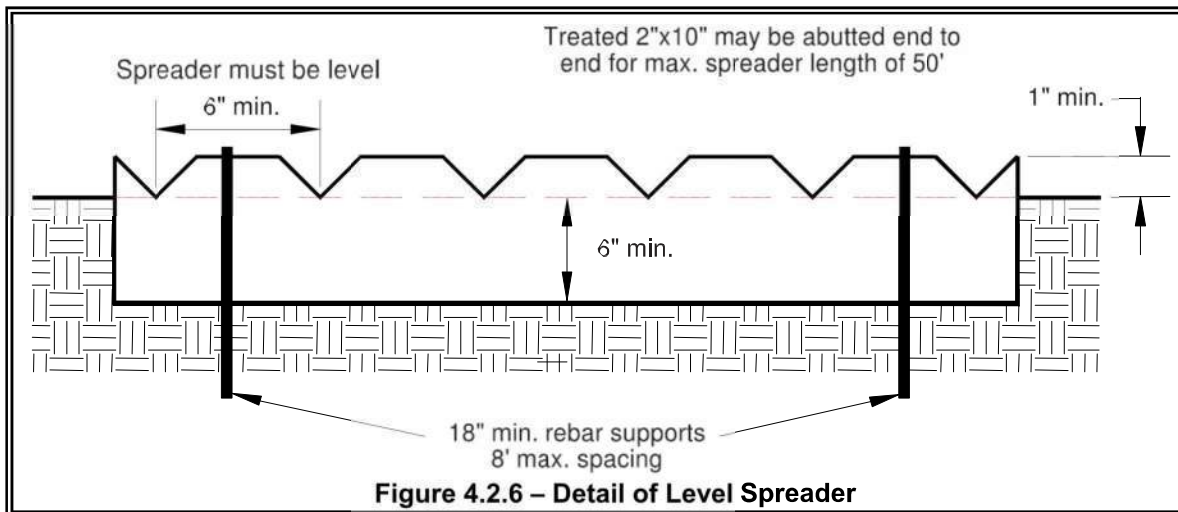

Figure 4.2.4 – Pipe Slope Drain



BMP C207: Check Dams

Purpose

Construction of small dams across a swale or ditch reduces the velocity of concentrated flow and dissipates energy at the check dam.

Conditions of Use

Where temporary channels or permanent channels are not yet vegetated, channel lining is infeasible, and/or velocity checks are required.

- Check dams may not be placed in streams unless approved by the State Department of Fish and Wildlife. Check dams may not be placed in wetlands without approval from a permitting agency.
- Do not place check dams below the expected backwater from any salmonid bearing water between October 1 and May 31 to ensure that there is no loss of high flow refuge habitat for overwintering juvenile salmonids and emergent salmonid fry.
- Construct rock check dams from appropriately sized rock. The rock used must be large enough to stay in place given the expected design flow through the channel. The rock must be placed by hand or by mechanical means (no dumping of rock to form dam) to achieve complete coverage of the ditch or swale and to ensure that the center of the dam is lower than the edges.
- Check dams may also be constructed of either rock or pea-gravel filled bags. Numerous new products are also available for this purpose. They tend to be re-usable, quick and easy to install, effective, and cost efficient.
- Place check dams perpendicular to the flow of water.
- The dam should form a triangle when viewed from the side. This prevents undercutting as water flows over the face of the dam rather than falling directly onto the ditch bottom.

- Before installing check dams impound and bypass upstream water flow away from the work area. Options for bypassing include pumps, siphons, or temporary channels.
- Check dams in association with sumps work more effectively at slowing flow and retaining sediment than just a check dam alone. A deep sump should be provided immediately upstream of the check dam.
- In some cases, if carefully located and designed, check dams can remain as permanent installations with very minor regrading. They may be left as either spillways, in which case accumulated sediment would be graded and seeded, or as check dams to prevent further sediment from leaving the site.
- The maximum spacing between the dams shall be such that the toe of the upstream dam is at the same elevation as the top of the downstream dam.
- Keep the maximum height at 2 feet at the center of the dam.
- Keep the center of the check dam at least 12 inches lower than the outer edges at natural ground elevation.
- Keep the side slopes of the check dam at 2H:1V or flatter.
- Key the stone into the ditch banks and extend it beyond the abutments a minimum of 18 inches to avoid washouts from overflow around the dam.
- Use filter fabric foundation under a rock or sand bag check dam. If a blanket ditch liner is used, filter fabric is not necessary. A piece of organic or synthetic blanket cut to fit will also work for this purpose.
- In the case of grass-lined ditches and swales, all check dams and accumulated sediment shall be removed when the grass has matured sufficiently to protect the ditch or swale - unless the slope of the swale is greater than 4 percent. The area beneath the check dams shall be seeded and mulched immediately after dam removal.
- Ensure that channel appurtenances, such as culvert entrances below check dams, are not subject to damage or blockage from displaced stones. [Figure 4.2.7](#) depicts a typical rock check dam.

Maintenance Standards

Check dams shall be monitored for performance and sediment accumulation during and after each runoff producing rainfall. Sediment shall be removed when it reaches one half the sump depth.

- Anticipate submergence and deposition above the check dam and erosion from high flows around the edges of the dam.
- If significant erosion occurs between dams, install a protective riprap liner in that portion of the channel.

***Approved as
Equivalent***

Ecology has approved products as able to meet the requirements of [BMP C207](#). The products did not pass through the Technology Assessment Protocol – Ecology (TAPE) process. Local jurisdictions may choose not to accept this product approved as equivalent, or may require additional testing prior to consideration for local use. The products are available for review on Ecology’s website at <http://www.ecy.wa.gov/programs/wq/stormwater/newtech/equivalent.html>

View Looking Upstream

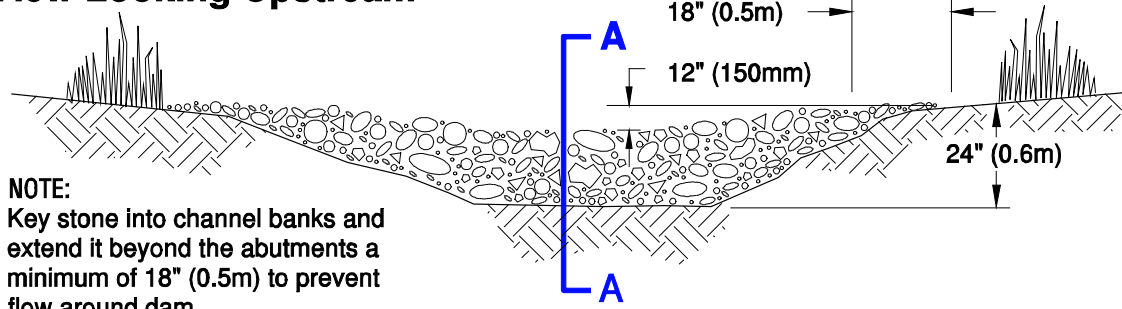

NOTE:
Key stone into channel banks and extend it beyond the abutments a minimum of 18" (0.5m) to prevent flow around dam.

Section A - A

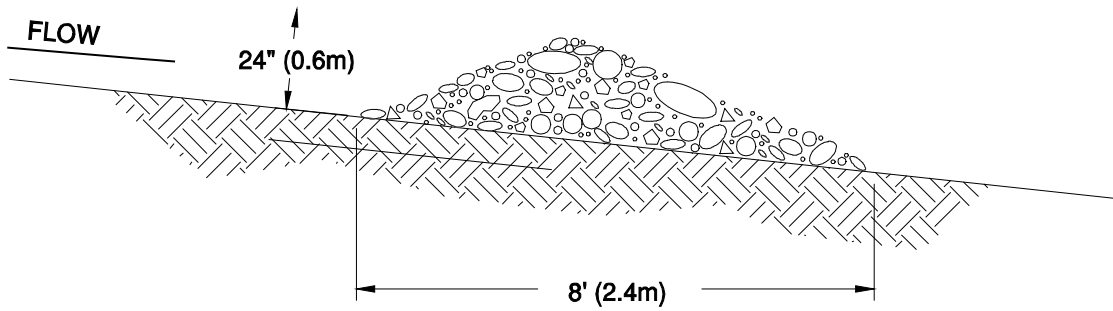

Spacing Between Check Dams

'L' = the distance such that points 'A' and 'B' are of equal elevation.

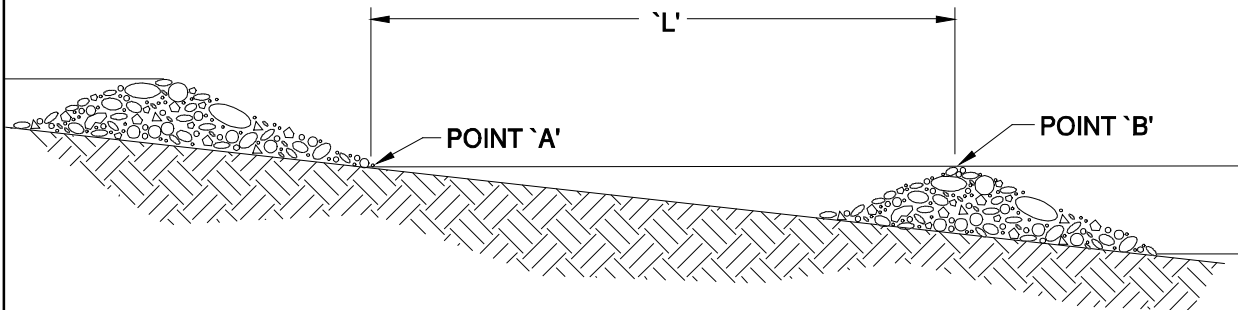

NOT TO SCALE

Figure 4.2.7 – Rock Check Dam

Standards

accumulation during and after each runoff producing rainfall. Sediment shall be removed when it reaches one half the height of the dam.

- Anticipate submergence and deposition above the triangular silt dam and erosion from high flows around the edges of the dam. Immediately repair any damage or any undercutting of the dam.

BMP C209: Outlet Protection

Purpose

Outlet protection prevents scour at conveyance outlets and minimizes the potential for downstream erosion by reducing the velocity of concentrated stormwater flows.

Conditions of use

Outlet protection is required at the outlets of all ponds, pipes, ditches, or other conveyances, and where runoff is conveyed to a natural or manmade drainage feature such as a stream, wetland, lake, or ditch.

Design and Installation Specifications

The receiving channel at the outlet of a culvert shall be protected from erosion by rock lining a minimum of 6 feet downstream and extending up the channel sides a minimum of 1-foot above the maximum tailwater elevation or 1-foot above the crown, whichever is higher. For large pipes (more than 18 inches in diameter), the outlet protection lining of the channel is lengthened to four times the diameter of the culvert.

- Standard wingwalls, and tapered outlets and paved channels should also be considered when appropriate for permanent culvert outlet protection. (See WSDOT Hydraulic Manual, available through WSDOT Engineering Publications).
- Organic or synthetic erosion blankets, with or without vegetation, are usually more effective than rock, cheaper, and easier to install. Materials can be chosen using manufacturer product specifications. ASTM test results are available for most products and the designer can choose the correct material for the expected flow.
- With low flows, vegetation (including sod) can be effective.
- The following guidelines shall be used for riprap outlet protection:
 1. If the discharge velocity at the outlet is less than 5 fps (pipe slope less than 1 percent), use 2-inch to 8-inch riprap. Minimum thickness is 1-foot.
 2. For 5 to 10 fps discharge velocity at the outlet (pipe slope less than 3 percent), use 24-inch to 48-inch riprap. Minimum thickness is 2 feet.
 3. For outlets at the base of steep slope pipes (pipe slope greater than 10 percent), an engineered energy dissipater shall be used.
- Filter fabric or erosion control blankets should always be used under riprap to prevent scour and channel erosion.

- New pipe outfalls can provide an opportunity for low-cost fish habitat improvements. For example, an alcove of low-velocity water can be created by constructing the pipe outfall and associated energy dissipater back from the stream edge and digging a channel, over-widened to the upstream side, from the outfall. Overwintering juvenile and migrating adult salmonids may use the alcove as shelter during high flows. Bank stabilization, bioengineering, and habitat features may be required for disturbed areas. This work may require a HPA. See Volume V for more information on outfall system design.

Maintenance Standards

- Inspect and repair as needed.
- Add rock as needed to maintain the intended function.
- Clean energy dissipater if sediment builds up.

BMP C220: Storm Drain Inlet Protection

Purpose

Storm drain inlet protection prevents coarse sediment from entering drainage systems prior to permanent stabilization of the disturbed area.

Conditions of Use

Use storm drain inlet protection at inlets that are operational before permanent stabilization of the disturbed drainage area. Provide protection for all storm drain inlets downslope and within 500 feet of a disturbed or construction area, unless conveying runoff entering catch basins to a sediment pond or trap.

Also consider inlet protection for lawn and yard drains on new home construction. These small and numerous drains coupled with lack of gutters in new home construction can add significant amounts of sediment into the roof drain system. If possible delay installing lawn and yard drains until just before landscaping or cap these drains to prevent sediment from entering the system until completion of landscaping. Provide 18-inches of sod around each finished lawn and yard drain.

[Table 4.2.2](#) lists several options for inlet protection. All of the methods for storm drain inlet protection tend to plug and require a high frequency of maintenance. Limit drainage areas to one acre or less. Possibly provide emergency overflows with additional end-of-pipe treatment where stormwater ponding would cause a hazard.

**Table 4.2.2
Storm Drain Inlet Protection**

Type of Inlet Protection	Emergency Overflow	Applicable for Paved/ Earthen Surfaces	Conditions of Use
Drop Inlet Protection			
Excavated drop inlet protection	Yes, temporary flooding will occur	Earthen	Applicable for heavy flows. Easy to maintain. Large area Requirement: 30' X 30'/acre
Block and gravel drop inlet protection	Yes	Paved or Earthen	Applicable for heavy concentrated flows. Will not pond.
Gravel and wire drop inlet protection	No		Applicable for heavy concentrated flows. Will pond. Can withstand traffic.
Catch basin filters	Yes	Paved or Earthen	Frequent maintenance required.
Curb Inlet Protection			
Curb inlet protection with a wooden weir	Small capacity overflow	Paved	Used for sturdy, more compact installation.
Block and gravel curb inlet protection	Yes	Paved	Sturdy, but limited filtration.
Culvert Inlet Protection			
Culvert inlet sediment trap			18 month expected life.

Design and Installation Specifications

Excavated Drop Inlet Protection - An excavated impoundment around the storm drain. Sediment settles out of the stormwater prior to entering the storm drain.

- Provide a depth of 1-2 ft as measured from the crest of the inlet structure.
- Slope sides of excavation no steeper than 2H:1V.
- Minimum volume of excavation 35 cubic yards.
- Shape basin to fit site with longest dimension oriented toward the longest inflow area.
- Install provisions for draining to prevent standing water problems.
- Clear the area of all debris.
- Grade the approach to the inlet uniformly.
- Drill weep holes into the side of the inlet.
- Protect weep holes with screen wire and washed aggregate.
- Seal weep holes when removing structure and stabilizing area.

- Build a temporary dike, if necessary, to the down slope side of the structure to prevent bypass flow.

Block and Gravel Filter - A barrier formed around the storm drain inlet with standard concrete blocks and gravel. See [Figure 4.2.8](#).

- Provide a height of 1 to 2 feet above inlet.
- Recess the first row 2-inches into the ground for stability.
- Support subsequent courses by placing a 2x4 through the block opening.
- Do not use mortar.
- Lay some blocks in the bottom row on their side for dewatering the pool.
- Place hardware cloth or comparable wire mesh with ½-inch openings over all block openings.
- Place gravel just below the top of blocks on slopes of 2H:1V or flatter.
- An alternative design is a gravel donut.
- Provide an inlet slope of 3H:1V.
- Provide an outlet slope of 2H:1V.
- Provide a 1-foot wide level stone area between the structure and the inlet.
- Use inlet slope stones 3 inches in diameter or larger.
- Use gravel ½- to ¾-inch at a minimum thickness of 1-foot for the outlet slope.

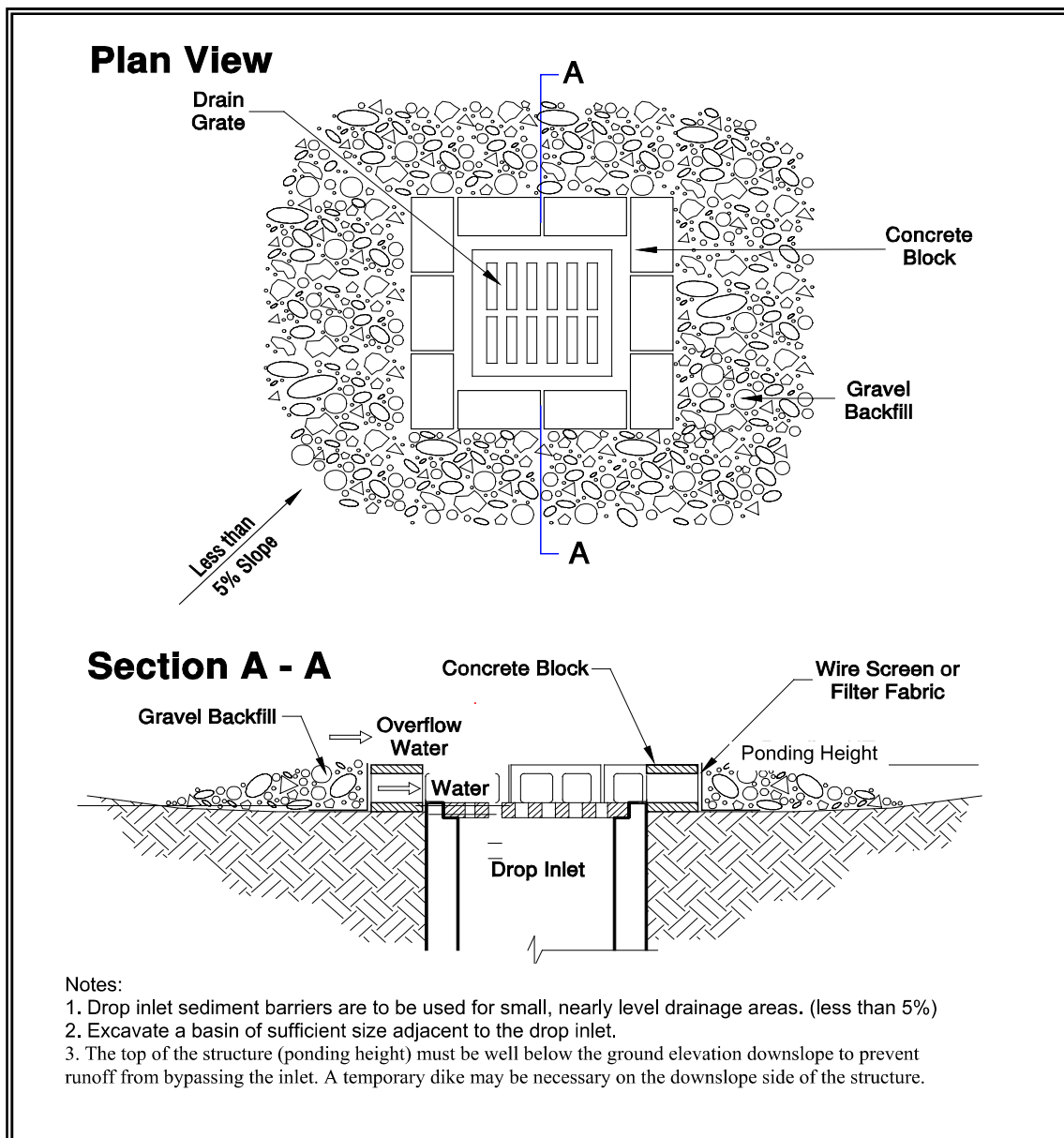

Figure 4.2.8 – Block and Gravel Filter

Gravel and Wire Mesh Filter - A gravel barrier placed over the top of the inlet. This structure does not provide an overflow.

- Use a hardware cloth or comparable wire mesh with ½-inch openings.
- Use coarse aggregate.
- Provide a height 1-foot or more, 18-inches wider than inlet on all sides.
- Place wire mesh over the drop inlet so that the wire extends a minimum of 1-foot beyond each side of the inlet structure.
- Overlap the strips if more than one strip of mesh is necessary.

- Place coarse aggregate over the wire mesh.
- Provide at least a 12-inch depth of gravel over the entire inlet opening and extend at least 18-inches on all sides.

Catchbasin Filters – Use inserts designed by manufacturers for construction sites. The limited sediment storage capacity increases the amount of inspection and maintenance required, which may be daily for heavy sediment loads. To reduce maintenance requirements combine a catchbasin filter with another type of inlet protection. This type of inlet protection provides flow bypass without overflow and therefore may be a better method for inlets located along active rights-of-way.

- Provides 5 cubic feet of storage.
- Requires dewatering provisions.
- Provides a high-flow bypass that will not clog under normal use at a construction site.
- Insert the catchbasin filter in the catchbasin just below the grating.

Curb Inlet Protection with Wooden Weir – Barrier formed around a curb inlet with a wooden frame and gravel.

- Use wire mesh with ½-inch openings.
- Use extra strength filter cloth.
- Construct a frame.
- Attach the wire and filter fabric to the frame.
- Pile coarse washed aggregate against wire/fabric.
- Place weight on frame anchors.

Block and Gravel Curb Inlet Protection – Barrier formed around a curb inlet with concrete blocks and gravel. See [Figure 4.2.9](#).

- Use wire mesh with ½-inch openings.
- Place two concrete blocks on their sides abutting the curb at either side of the inlet opening. These are spacer blocks.
- Place a 2x4 stud through the outer holes of each spacer block to align the front blocks.
- Place blocks on their sides across the front of the inlet and abutting the spacer blocks.
- Place wire mesh over the outside vertical face.
- Pile coarse aggregate against the wire to the top of the barrier.

Curb and Gutter Sediment Barrier – Sandbag or rock berm (riprap and aggregate) 3 feet high and 3 feet wide in a horseshoe shape. See [Figure 4.2.10](#).

***Maintenance
Standards***

- Construct a horseshoe shaped berm, faced with coarse aggregate if using riprap, 3 feet high and 3 feet wide, at least 2 feet from the inlet.
- Construct a horseshoe shaped sedimentation trap on the outside of the berm sized to sediment trap standards for protecting a culvert inlet.
- Inspect catch basin filters frequently, especially after storm events. Clean and replace clogged inserts. For systems with clogged stone filters: pull away the stones from the inlet and clean or replace. An alternative approach would be to use the clogged stone as fill and put fresh stone around the inlet.
- Do not wash sediment into storm drains while cleaning. Spread all excavated material evenly over the surrounding land area or stockpile and stabilize as appropriate.

***Approved as
Equivalent***

Ecology has approved products as able to meet the requirements of [BMP C220](#). The products did not pass through the Technology Assessment Protocol – Ecology (TAPE) process. Local jurisdictions may choose not to accept this product approved as equivalent, or may require additional testing prior to consideration for local use. The products are available for review on Ecology’s website at <http://www.ecy.wa.gov/programs/wq/stormwater/newtech/equivalent.html>

Plan View

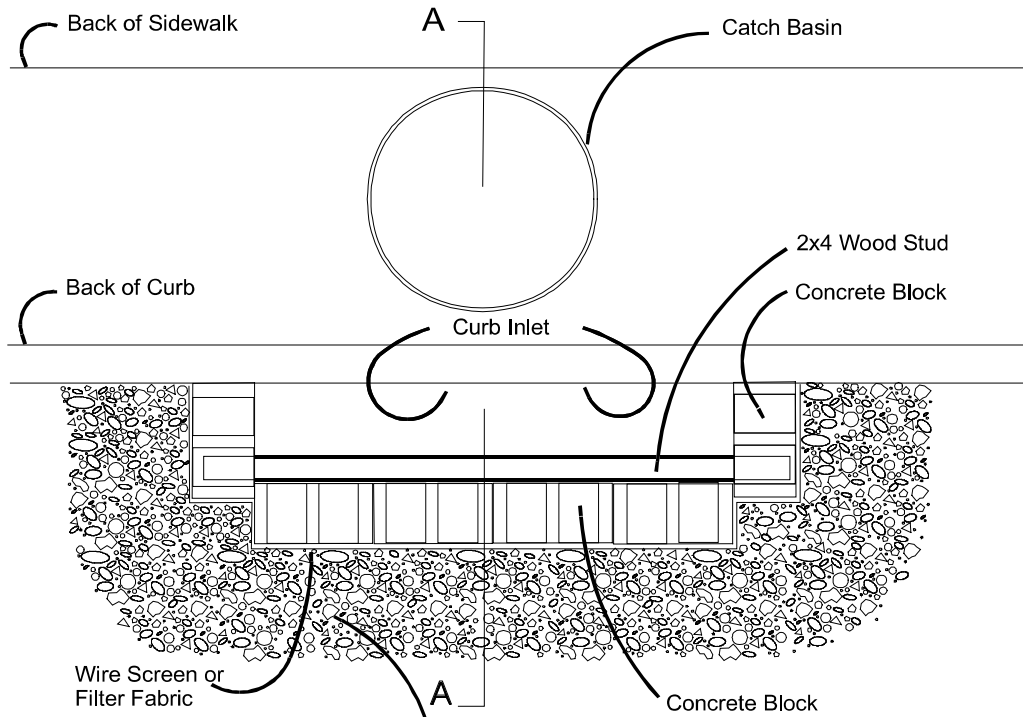

Section A - A

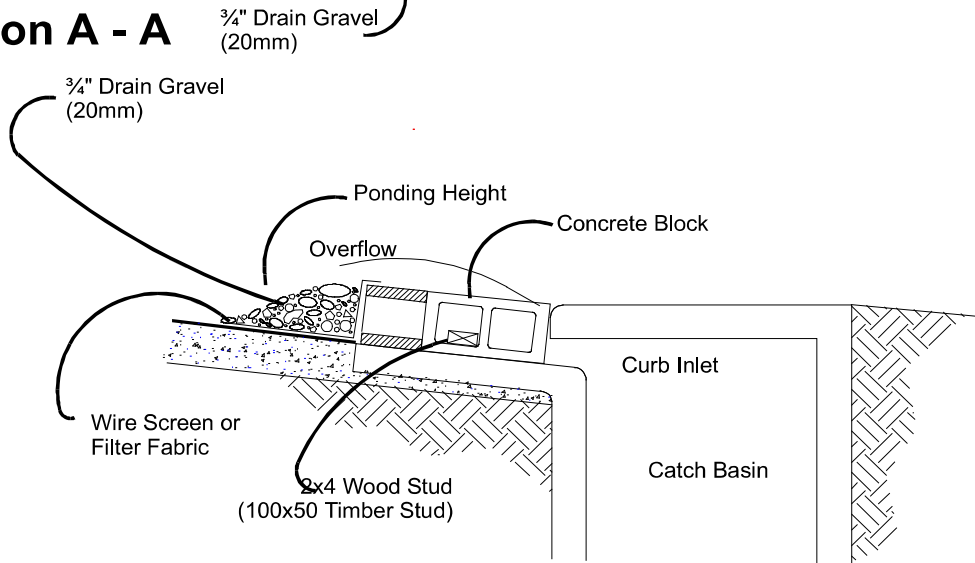

NOTES:

1. Use block and gravel type sediment barrier when curb inlet is located in gently sloping street segment, where water can pond and allow sediment to separate from runoff.
2. Barrier shall allow for overflow from severe storm event.
3. Inspect barriers and remove sediment after each storm event. Sediment and gravel must be removed from the traveled way immediately.

Figure 4.2.9 – Block and Gravel Curb Inlet Protection

Plan View

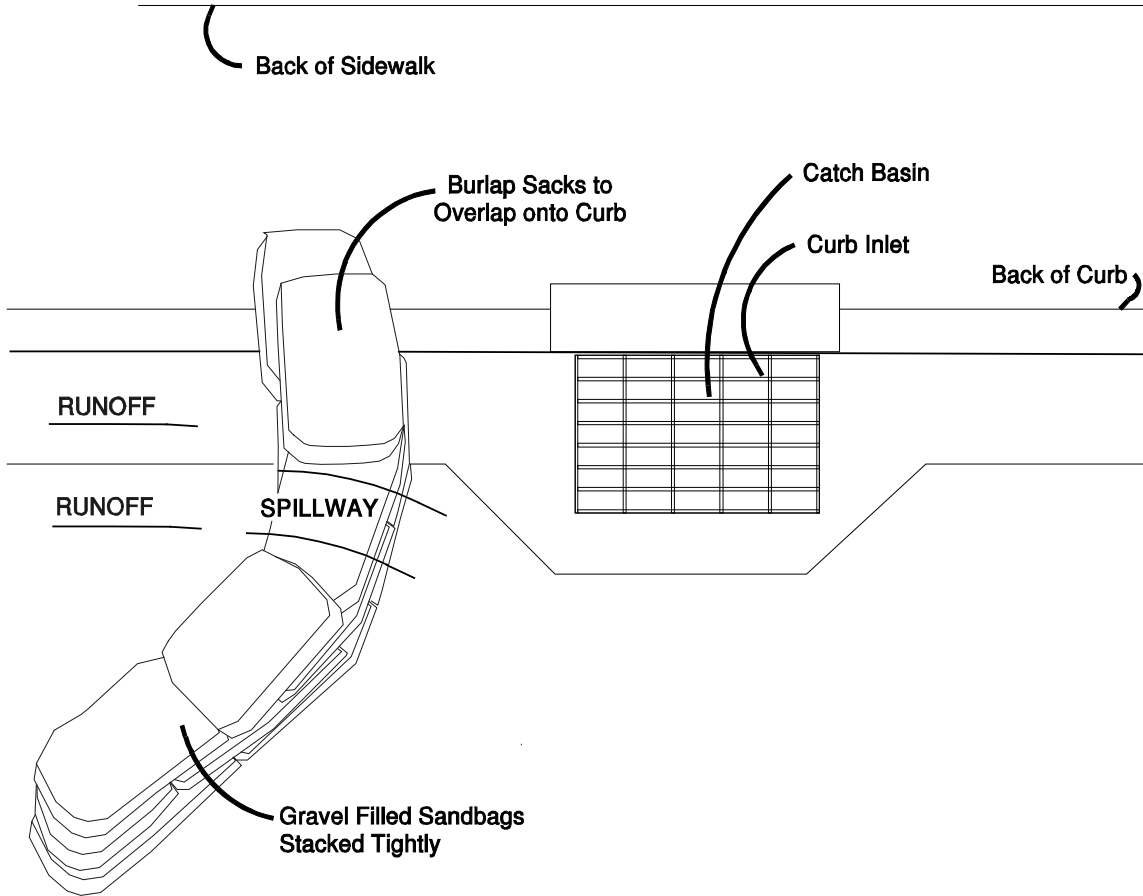

NOTES:

1. Place curb type sediment barriers on gently sloping street segments, where water can pond and allow sediment to separate from runoff.
2. Sandbags of either burlap or woven 'geotextile' fabric, are filled with gravel, layered and packed tightly.
3. Leave a one sandbag gap in the top row to provide a spillway for overflow.
4. Inspect barriers and remove sediment after each storm event. Sediment and gravel must be removed from the traveled way immediately.

Figure 4.2.10 – Curb and Gutter Barrier

BMP C232: Gravel Filter Berm

<i>Purpose</i>	A gravel filter berm is constructed on rights-of-way or traffic areas within a construction site to retain sediment by using a filter berm of gravel or crushed rock.
<i>Conditions of Use</i>	Where a temporary measure is needed to retain sediment from rights-of-way or in traffic areas on construction sites.
<i>Design and Installation Specifications</i>	<ul style="list-style-type: none">• Berm material shall be $\frac{3}{4}$ to 3 inches in size, washed well-grade gravel or crushed rock with less than 5 percent fines.• Spacing of berms:<ul style="list-style-type: none">– Every 300 feet on slopes less than 5 percent– Every 200 feet on slopes between 5 percent and 10 percent– Every 100 feet on slopes greater than 10 percent• Berm dimensions:<ul style="list-style-type: none">– 1 foot high with 3H:1V side slopes– 8 linear feet per 1 cfs runoff based on the 10-year, 24-hour design storm
<i>Maintenance Standards</i>	<ul style="list-style-type: none">• Regular inspection is required. Sediment shall be removed and filter material replaced as needed.

BMP C233: Silt Fence

<i>Purpose</i>	Use of a silt fence reduces the transport of coarse sediment from a construction site by providing a temporary physical barrier to sediment and reducing the runoff velocities of overland flow. See Figure 4.2.12 for details on silt fence construction.
<i>Conditions of Use</i>	Silt fence may be used downslope of all disturbed areas. <ul style="list-style-type: none">• Silt fence shall prevent soil carried by runoff water from going beneath, through, or over the top of the silt fence, but shall allow the water to pass through the fence.• Silt fence is not intended to treat concentrated flows, nor is it intended to treat substantial amounts of overland flow. Convey any concentrated flows through the drainage system to a sediment pond.• Do not construct silt fences in streams or use in V-shaped ditches. Silt fences do not provide an adequate method of silt control for anything deeper than sheet or overland flow.

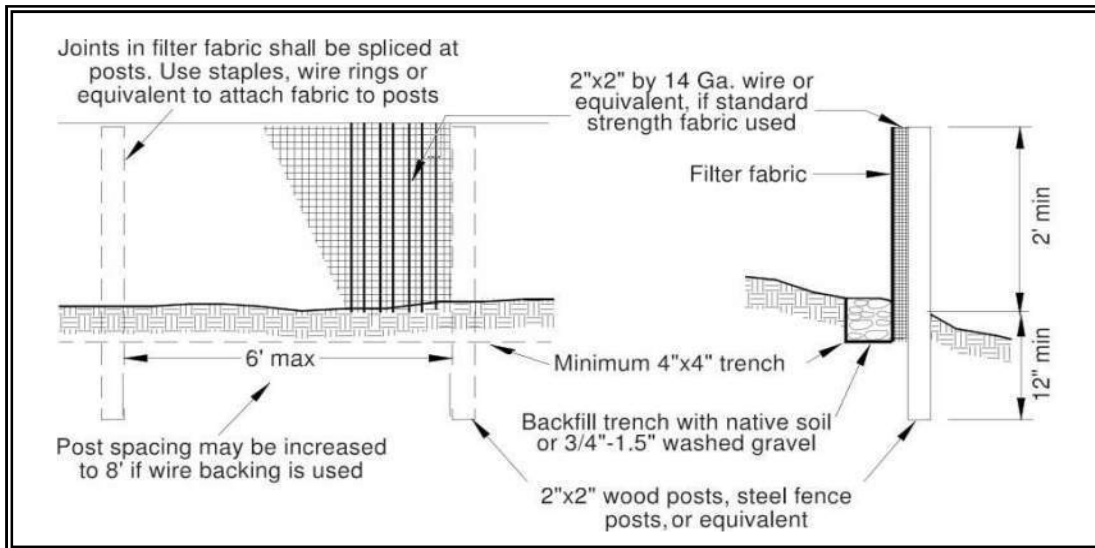

Figure 4.2.12 – Silt Fence

Design and Installation Specifications

- Use in combination with sediment basins or other BMPs.
- Maximum slope steepness (normal (perpendicular) to fence line) 1H:1V.
- Maximum sheet or overland flow path length to the fence of 100 feet.
- Do not allow flows greater than 0.5 cfs.
- The geotextile used shall meet the following standards. All geotextile properties listed below are minimum average roll values (i.e., the test result for any sampled roll in a lot shall meet or exceed the values shown in [Table 4.2.3](#)):

Table 4.2.3 Geotextile Standards	
Polymeric Mesh AOS (ASTM D4751)	0.60 mm maximum for slit film woven (#30 sieve). 0.30 mm maximum for all other geotextile types (#50 sieve). 0.15 mm minimum for all fabric types (#100 sieve).
Water Permittivity (ASTM D4491)	0.02 sec ⁻¹ minimum
Grab Tensile Strength (ASTM D4632)	180 lbs. Minimum for extra strength fabric. 100 lbs minimum for standard strength fabric.
Grab Tensile Strength (ASTM D4632)	30% maximum
Ultraviolet Resistance (ASTM D4355)	70% minimum

- Support standard strength fabrics with wire mesh, chicken wire, 2-inch x 2-inch wire, safety fence, or jute mesh to increase the strength of the

fabric. Silt fence materials are available that have synthetic mesh backing attached.

- Filter fabric material shall contain ultraviolet ray inhibitors and stabilizers to provide a minimum of six months of expected usable construction life at a temperature range of 0°F. to 120°F.
- One-hundred percent biodegradable silt fence is available that is strong, long lasting, and can be left in place after the project is completed, if permitted by local regulations.
- Refer to [Figure 4.2.12](#) for standard silt fence details. Include the following standard Notes for silt fence on construction plans and specifications:
 1. The contractor shall install and maintain temporary silt fences at the locations shown in the Plans.
 2. Construct silt fences in areas of clearing, grading, or drainage prior to starting those activities.
 3. The silt fence shall have a 2-foot min. and a 2½-foot max. height above the original ground surface.
 4. The filter fabric shall be sewn together at the point of manufacture to form filter fabric lengths as required. Locate all sewn seams at support posts. Alternatively, two sections of silt fence can be overlapped, provided the Contractor can demonstrate, to the satisfaction of the Engineer, that the overlap is long enough and that the adjacent fence sections are close enough together to prevent silt laden water from escaping through the fence at the overlap.
 5. Attach the filter fabric on the up-slope side of the posts and secure with staples, wire, or in accordance with the manufacturer's recommendations. Attach the filter fabric to the posts in a manner that reduces the potential for tearing.
 6. Support the filter fabric with wire or plastic mesh, dependent on the properties of the geotextile selected for use. If wire or plastic mesh is used, fasten the mesh securely to the up-slope side of the posts with the filter fabric up-slope of the mesh.
 7. Mesh support, if used, shall consist of steel wire with a maximum mesh spacing of 2-inches, or a prefabricated polymeric mesh. The strength of the wire or polymeric mesh shall be equivalent to or greater than 180 lbs. grab tensile strength. The polymeric mesh must be as resistant to the same level of ultraviolet radiation as the filter fabric it supports.
 8. Bury the bottom of the filter fabric 4-inches min. below the ground surface. Backfill and tamp soil in place over the buried portion of the filter fabric, so that no flow can pass beneath the fence and

scouring cannot occur. When wire or polymeric back-up support mesh is used, the wire or polymeric mesh shall extend into the ground 3-inches min.

9. Drive or place the fence posts into the ground 18-inches min. A 12-inch min. depth is allowed if topsoil or other soft subgrade soil is not present and 18-inches cannot be reached. Increase fence post min. depths by 6 inches if the fence is located on slopes of 3H:1V or steeper and the slope is perpendicular to the fence. If required post depths cannot be obtained, the posts shall be adequately secured by bracing or guying to prevent overturning of the fence due to sediment loading.
 10. Use wood, steel or equivalent posts. The spacing of the support posts shall be a maximum of 6-feet. Posts shall consist of either:
 - Wood with dimensions of 2-inches by 2-inches wide min. and a 3-feet min. length. Wood posts shall be free of defects such as knots, splits, or gouges.
 - No. 6 steel rebar or larger.
 - ASTM A 120 steel pipe with a minimum diameter of 1-inch.
 - U, T, L, or C shape steel posts with a minimum weight of 1.35 lbs./ft.
 - Other steel posts having equivalent strength and bending resistance to the post sizes listed above.
 11. Locate silt fences on contour as much as possible, except at the ends of the fence, where the fence shall be turned uphill such that the silt fence captures the runoff water and prevents water from flowing around the end of the fence.
 12. If the fence must cross contours, with the exception of the ends of the fence, place gravel check dams perpendicular to the back of the fence to minimize concentrated flow and erosion. The slope of the fence line where contours must be crossed shall not be steeper than 3H:1V.
 - Gravel check dams shall be approximately 1-foot deep at the back of the fence. Gravel check dams shall be continued perpendicular to the fence at the same elevation until the top of the check dam intercepts the ground surface behind the fence.
 - Gravel check dams shall consist of crushed surfacing base course, gravel backfill for walls, or shoulder ballast. Gravel check dams shall be located every 10 feet along the fence where the fence must cross contours.
- Refer to [Figure 4.2.13](#) for slicing method details. Silt fence installation using the slicing method specifications:

1. The base of both end posts must be at least 2- to 4-inches above the top of the filter fabric on the middle posts for ditch checks to drain properly. Use a hand level or string level, if necessary, to mark base points before installation.
2. Install posts 3- to 4-feet apart in critical retention areas and 6- to 7-feet apart in standard applications.
3. Install posts 24-inches deep on the downstream side of the silt fence, and as close as possible to the filter fabric, enabling posts to support the filter fabric from upstream water pressure.
4. Install posts with the nipples facing away from the filter fabric.
5. Attach the filter fabric to each post with three ties, all spaced within the top 8-inches of the filter fabric. Attach each tie diagonally 45 degrees through the filter fabric, with each puncture at least 1-inch vertically apart. Each tie should be positioned to hang on a post nipple when tightening to prevent sagging.
6. Wrap approximately 6-inches of fabric around the end posts and secure with 3 ties.
7. No more than 24-inches of a 36-inch filter fabric is allowed above ground level.

Compact the soil immediately next to the filter fabric with the front wheel of the tractor, skid steer, or roller exerting at least 60 pounds per square inch. Compact the upstream side first and then each side twice for a total of four trips. Check and correct the silt fence installation for any deviation before compaction. Use a flat-bladed shovel to tuck fabric deeper into the ground if necessary.

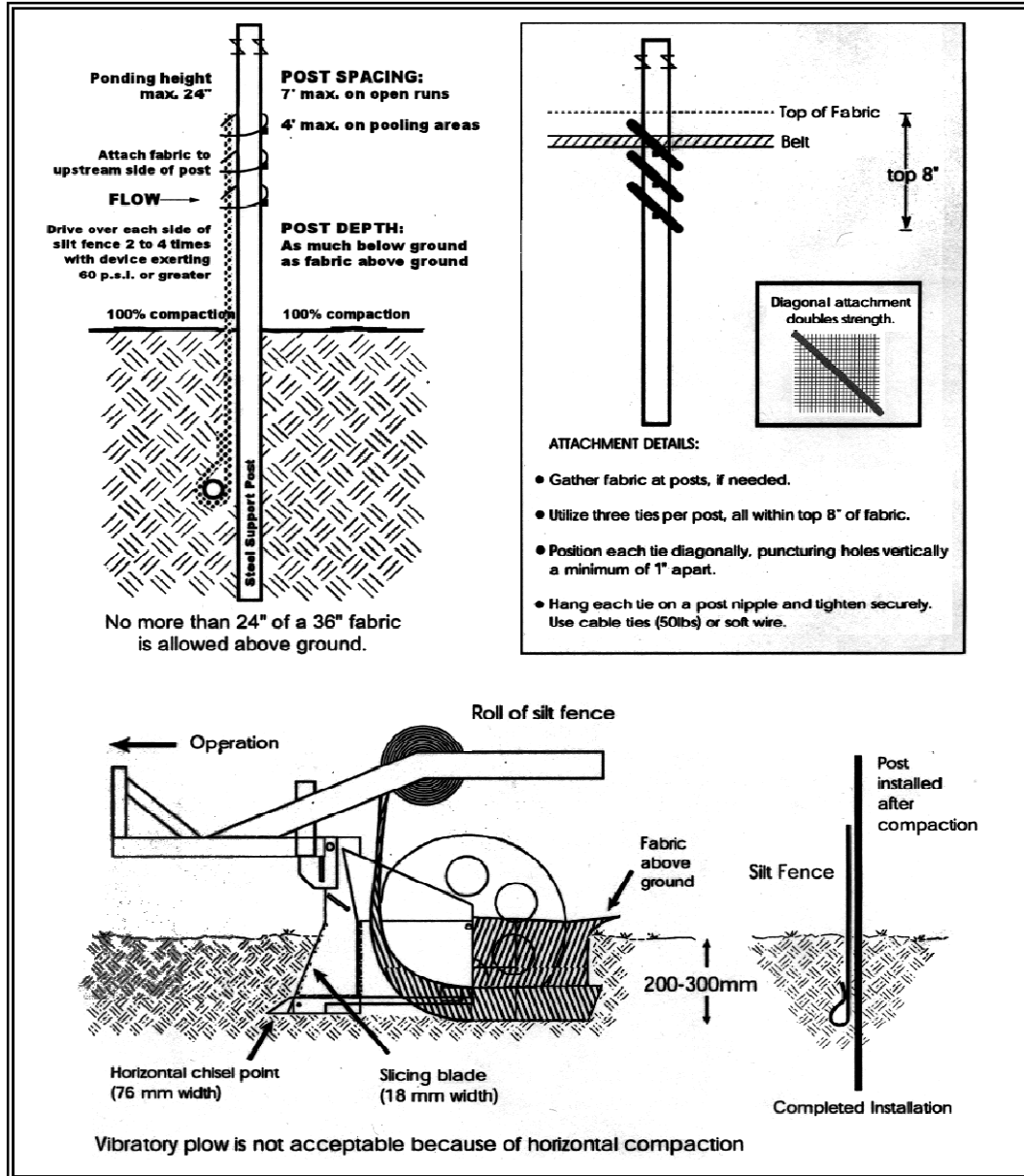

Figure 4.2.13 – Silt Fence Installation by Slicing Method

Maintenance Standards

- Repair any damage immediately.
- Intercept and convey all evident concentrated flows uphill of the silt fence to a sediment pond.
- Check the uphill side of the fence for signs of the fence clogging and acting as a barrier to flow and then causing channelization of flows parallel to the fence. If this occurs, replace the fence or remove the trapped sediment.

BMP C240: Sediment Trap

Purpose

A sediment trap is a small temporary ponding area with a gravel outlet used to collect and store sediment from sites cleared and/or graded during construction. Sediment traps, along with other perimeter controls, shall be installed before any land disturbance takes place in the drainage area.

Conditions of Use

Prior to leaving a construction site, stormwater runoff must pass through a sediment pond or trap or other appropriate sediment removal best management practice. Non-engineered sediment traps may be used on-site prior to an engineered sediment trap or sediment pond to provide additional sediment removal capacity.

It is intended for use on sites where the tributary drainage area is less than 3 acres, with no unusual drainage features, and a projected build-out time of six months or less. The sediment trap is a temporary measure (with a design life of approximately 6 months) and shall be maintained until the site area is permanently protected against erosion by vegetation and/or structures.

Sediment traps and ponds are only effective in removing sediment down to about the medium silt size fraction. Runoff with sediment of finer grades (fine silt and clay) will pass through untreated, emphasizing the need to control erosion to the maximum extent first.

Whenever possible, sediment-laden water shall be discharged into on-site, relatively level, vegetated areas (see [BMP C234 – Vegetated Strip](#)). This is the only way to effectively remove fine particles from runoff unless chemical treatment or filtration is used. This can be particularly useful after initial treatment in a sediment trap or pond. The areas of release must be evaluated on a site-by-site basis in order to determine appropriate locations for and methods of releasing runoff. Vegetated wetlands shall not be used for this purpose. Frequently, it may be possible to pump water from the collection point at the downhill end of the site to an upslope vegetated area. Pumping shall only augment the treatment system, not replace it, because of the possibility of pump failure or runoff volume in excess of pump capacity.

All projects that are constructing permanent facilities for runoff quantity control should use the rough-graded or final-graded permanent facilities for traps and ponds. This includes combined facilities and infiltration facilities. When permanent facilities are used as temporary sedimentation facilities, the surface area requirement of a sediment trap or pond must be met. If the surface area requirements are larger than the surface area of the permanent facility, then the trap or pond shall be enlarged to comply with the surface area requirement. The permanent pond shall also be divided into two cells as required for sediment ponds.

Either a permanent control structure or the temporary control structure (described in [BMP C241](#), Temporary Sediment Pond) can be used. If a permanent control structure is used, it may be advisable to partially restrict the lower orifice with gravel to increase residence time while still allowing dewatering of the pond. A shut-off valve may be added to the control structure to allow complete retention of stormwater in emergency situations. In this case, an emergency overflow weir must be added.

A skimmer may be used for the sediment trap outlet if approved by the Local Permitting Authority.

***Design and
Installation
Specifications***

- See [Figures 4.2.16](#) and [4.2.17](#) for details.
- If permanent runoff control facilities are part of the project, they should be used for sediment retention.
- To determine the sediment trap geometry, first calculate the design surface area (SA) of the trap, measured at the invert of the weir. Use the following equation:

$$SA = FS(Q_2/V_s)$$

where

Q_2 = Design inflow based on the peak discharge from the developed 2-year runoff event from the contributing drainage area as computed in the hydrologic analysis. The 10-year peak flow shall be used if the project size, expected timing and duration of construction, or downstream conditions warrant a higher level of protection. If no hydrologic analysis is required, the Rational Method may be used.

V_s = The settling velocity of the soil particle of interest. The 0.02 mm (medium silt) particle with an assumed density of 2.65 g/cm³ has been selected as the particle of interest and has a settling velocity (V_s) of 0.00096 ft/sec.

FS = A safety factor of 2 to account for non-ideal settling.

Therefore, the equation for computing surface area becomes:

$$SA = 2 \times Q_2 / 0.00096 \text{ or}$$

2080 square feet per cfs of inflow

Note: Even if permanent facilities are used, they must still have a surface area that is at least as large as that derived from the above formula. If they do not, the pond must be enlarged.

- To aid in determining sediment depth, all sediment traps shall have a staff gauge with a prominent mark 1-foot above the bottom of the trap.

- Sediment traps may not be feasible on utility projects due to the limited work space or the short-term nature of the work. Portable tanks may be used in place of sediment traps for utility projects.
- Maintenance Standards**
- Sediment shall be removed from the trap when it reaches 1-foot in depth.
 - Any damage to the pond embankments or slopes shall be repaired.

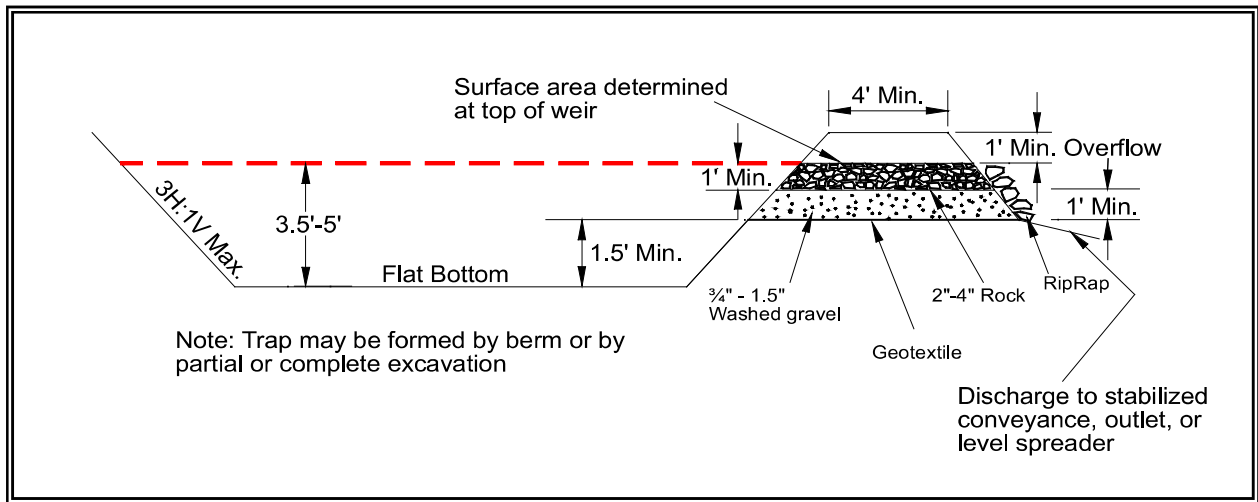

Figure 4.2.16 – Cross Section of Sediment Trap

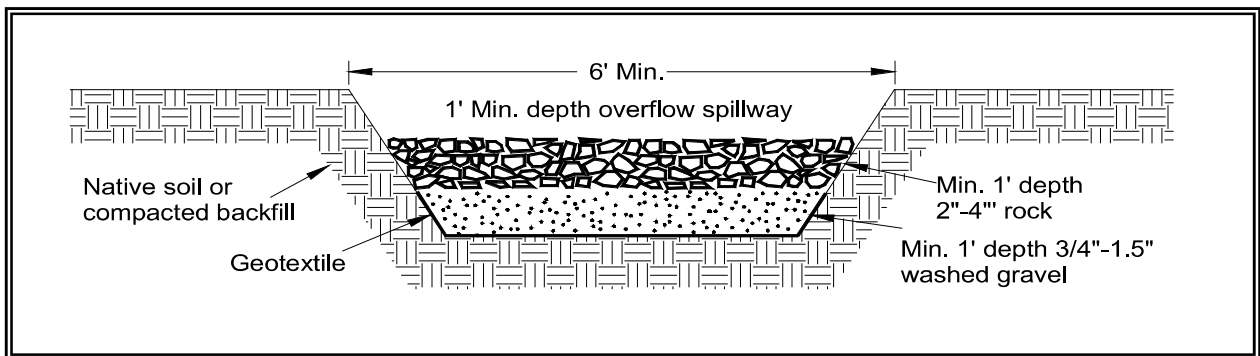

Figure 4.2.17 – Sediment Trap Outlet

BMP C241: Temporary Sediment Pond

Purpose Sediment ponds remove sediment from runoff originating from disturbed areas of the site. Sediment ponds are typically designed to remove sediment no smaller than medium silt (0.02 mm). Consequently, they usually reduce turbidity only slightly.

Conditions of Use Prior to leaving a construction site, stormwater runoff must pass through a sediment pond or other appropriate sediment removal best management practice.

A sediment pond shall be used where the contributing drainage area is 3 acres or more. Ponds must be used in conjunction with erosion control practices to reduce the amount of sediment flowing into the basin.

Design and Installation Specifications

- Sediment basins must be installed only on sites where failure of the structure would not result in loss of life, damage to homes or buildings, or interruption of use or service of public roads or utilities. Also, sediment traps and ponds are attractive to children and can be very dangerous. Compliance with local ordinances regarding health and safety must be addressed. If fencing of the pond is required, the type of fence and its location shall be shown on the ESC plan.
- Structures having a maximum storage capacity at the top of the dam of 10 acre-ft (435,600 ft³) or more are subject to the Washington Dam Safety Regulations ([Chapter 173-175 WAC](#)).
- See [Figures 4.2.18](#), [4.2.19](#), and [4.2.20](#) for details.
- If permanent runoff control facilities are part of the project, they should be used for sediment retention. The surface area requirements of the sediment basin must be met. This may require temporarily enlarging the permanent basin to comply with the surface area requirements. The permanent control structure must be temporarily replaced with a control structure that only allows water to leave the pond from the surface or by pumping. The permanent control structure must be installed after the site is fully stabilized. .
- Use of infiltration facilities for sedimentation basins during construction tends to clog the soils and reduce their capacity to infiltrate. If infiltration facilities are to be used, the sides and bottom of the facility must only be rough excavated to a minimum of 2 feet above final grade. Final grading of the infiltration facility shall occur only when all contributing drainage areas are fully stabilized. The infiltration pretreatment facility should be fully constructed and used with the sedimentation basin to help prevent clogging.
- Determining Pond Geometry
Obtain the discharge from the hydrologic calculations of the peak flow for the 2-year runoff event (Q_2). The 10-year peak flow shall be used if

the project size, expected timing and duration of construction, or downstream conditions warrant a higher level of protection. If no hydrologic analysis is required, the Rational Method may be used.

Determine the required surface area at the top of the riser pipe with the equation:

$$SA = 2 \times Q_2 / 0.00096 \quad \text{or} \\ 2080 \text{ square feet per cfs of inflow}$$

See [BMP C240](#) for more information on the derivation of the surface area calculation.

The basic geometry of the pond can now be determined using the following design criteria:

- Required surface area SA (from Step 2 above) at top of riser.
- Minimum 3.5-foot depth from top of riser to bottom of pond.
- Maximum 3H:1V interior side slopes and maximum 2H:1V exterior slopes. The interior slopes can be increased to a maximum of 2H:1V if fencing is provided at or above the maximum water surface.
- One foot of freeboard between the top of the riser and the crest of the emergency spillway.
- Flat bottom.
- Minimum 1-foot deep spillway.
- Length-to-width ratio between 3:1 and 6:1.
- Sizing of Discharge Mechanisms.

The outlet for the basin consists of a combination of principal and emergency spillways. These outlets must pass the peak runoff expected from the contributing drainage area for a 100-year storm. If, due to site conditions and basin geometry, a separate emergency spillway is not feasible, the principal spillway must pass the entire peak runoff expected from the 100-year storm. However, an attempt to provide a separate emergency spillway should always be made. The runoff calculations should be based on the site conditions during construction. The flow through the dewatering orifice cannot be utilized when calculating the 100-year storm elevation because of its potential to become clogged; therefore, available spillway storage must begin at the principal spillway riser crest.

The principal spillway designed by the procedures contained in this standard will result in some reduction in the peak rate of runoff. However, the riser outlet design will not adequately control the basin discharge to the predevelopment discharge limitations as stated in Minimum Requirement #7: Flow Control. However, if the basin for a permanent stormwater detention pond is used for a temporary

sedimentation basin, the control structure for the permanent pond can be used to maintain predevelopment discharge limitations. The size of the basin, the expected life of the construction project, the anticipated downstream effects and the anticipated weather conditions during construction, should be considered to determine the need of additional discharge control. See [Figure 4.2.21](#) for riser inflow curves.

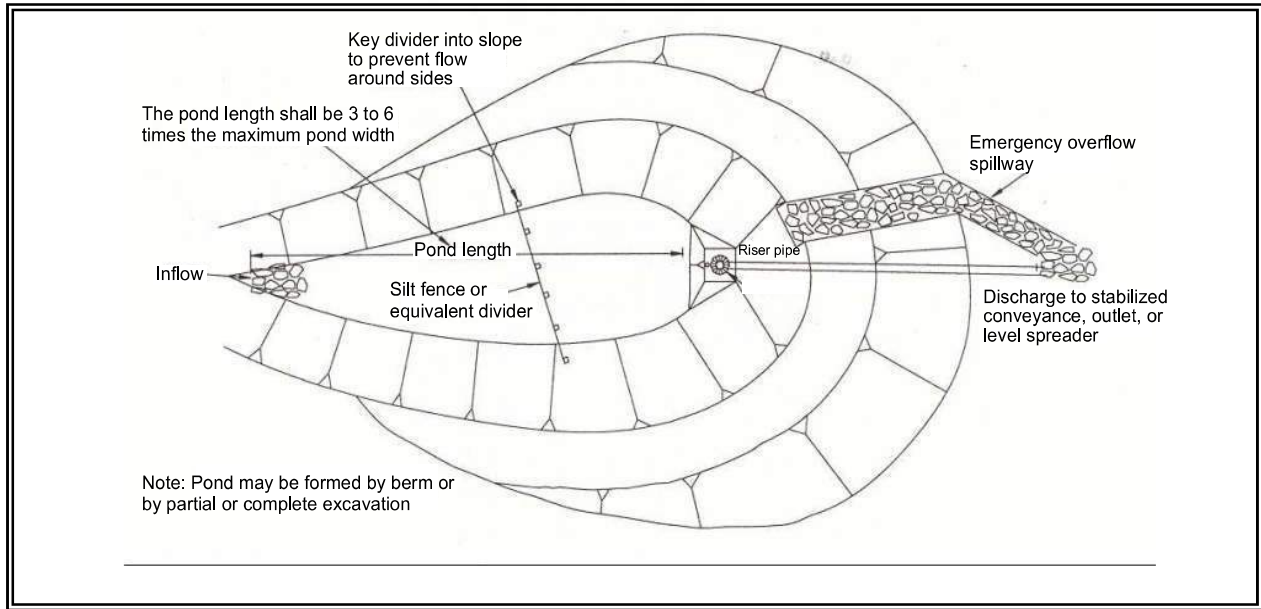

Figure 4.2.18 – Sediment Pond Plan View

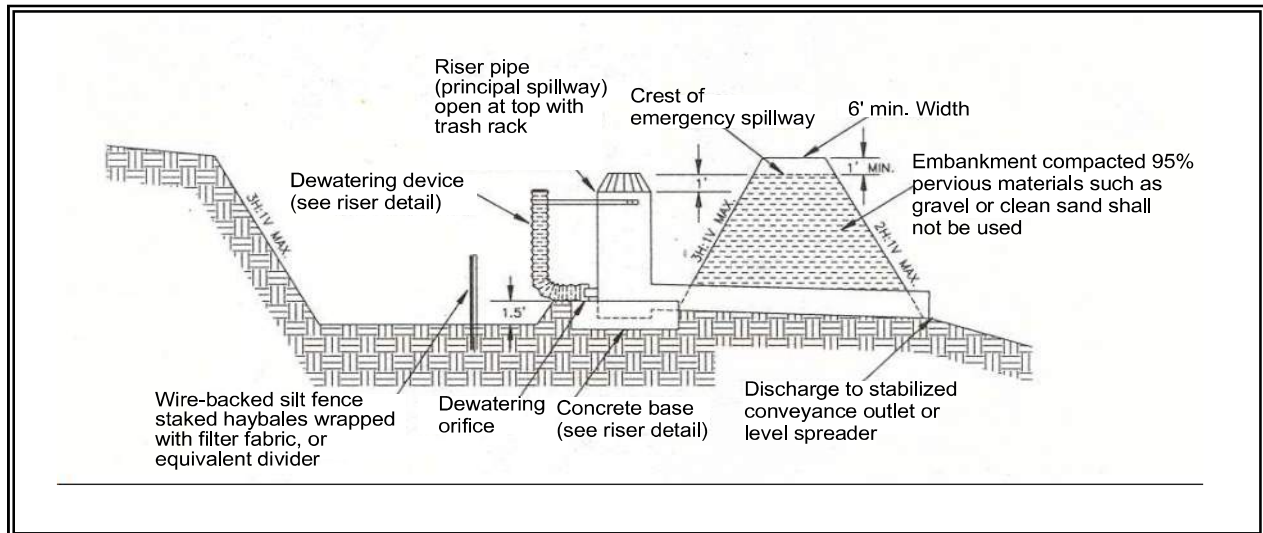

Figure 4.2.19 – Sediment Pond Cross Section

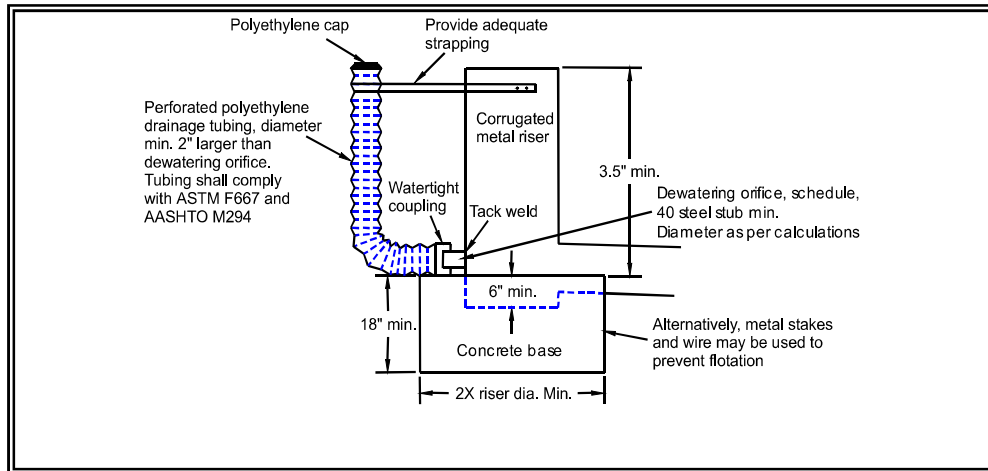

Figure 4.2.20 – Sediment Pond Riser Detail

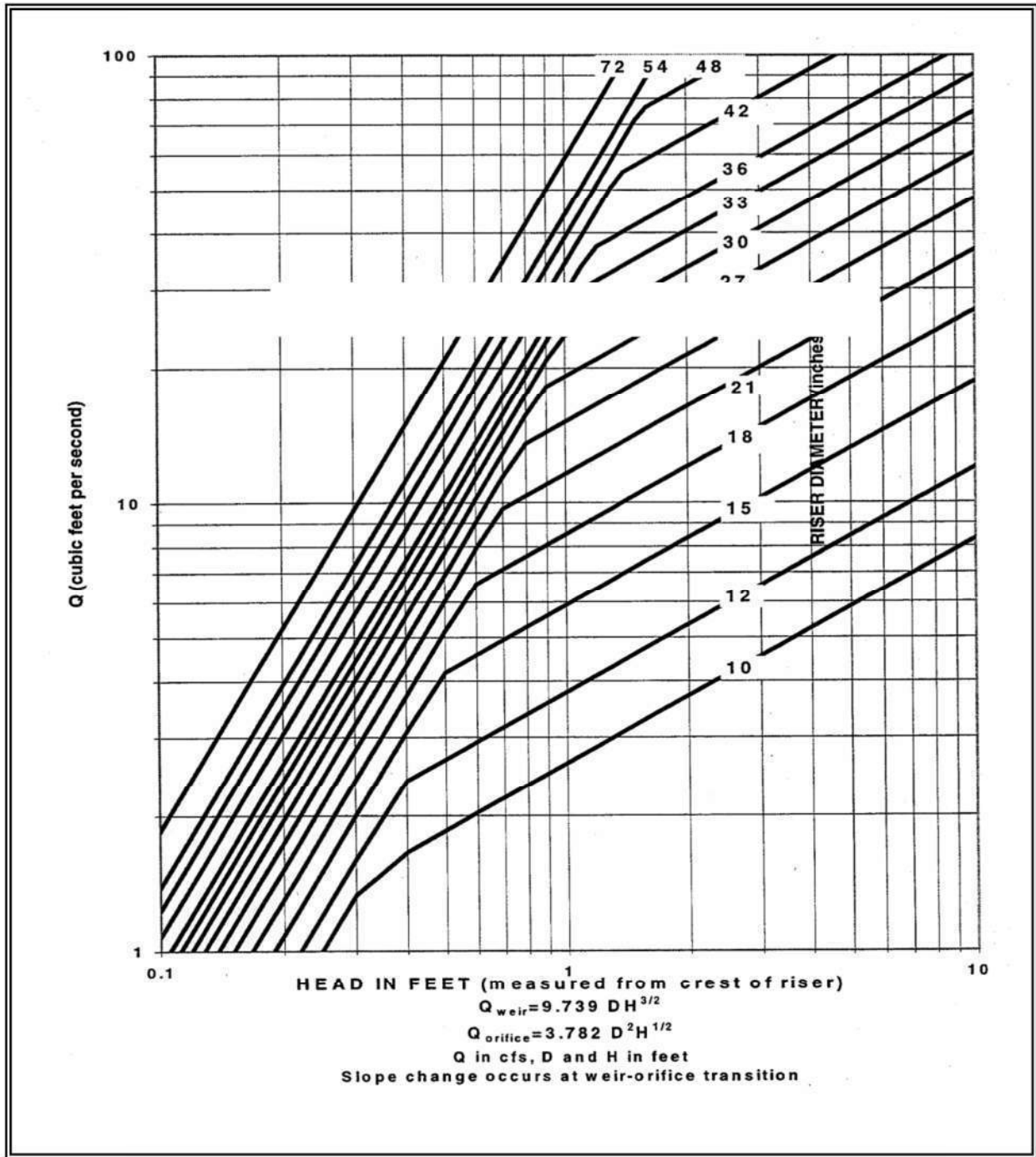

Figure 4.2.21 – Riser Inflow Curves

Principal Spillway: Determine the required diameter for the principal spillway (riser pipe). The diameter shall be the minimum necessary to pass the site's 15-minute, 10-year flowrate. If using the Western Washington Hydrology Model (WWHM), Version 2 or 3, design flow is the 10-year (1 hour) flow for the developed (unmitigated) site, multiplied by a factor of 1.6. Use Figure 4.2.21 to determine this diameter ($h = 1$ -foot). *Note: A permanent control structure may be used instead of a temporary riser.*

Emergency Overflow Spillway: Determine the required size and design of the emergency overflow spillway for the developed 100-year peak flow using the method contained in Volume III.

Dewatering Orifice: Determine the size of the dewatering orifice(s) (minimum 1-inch diameter) using a modified version of the discharge equation for a vertical orifice and a basic equation for the area of a circular orifice. Determine the required area of the orifice with the following equation:

$$A_o = \frac{A_s (2h)^{0.5}}{0.6 \times 3600 T g^{0.5}}$$

where A_o = orifice area (square feet)
 A_s = pond surface area (square feet)
 h = head of water above orifice (height of riser in feet)
 T = dewatering time (24 hours)
 g = acceleration of gravity (32.2 feet/second²)

Convert the required surface area to the required diameter D of the orifice:

$$D = 24 \times \sqrt{\frac{A_o}{\pi}} = 13.54 \times \sqrt{A_o}$$

The vertical, perforated tubing connected to the dewatering orifice must be at least 2 inches larger in diameter than the orifice to improve flow characteristics. The size and number of perforations in the tubing should be large enough so that the tubing does not restrict flow. The orifice should control the flow rate.

- **Additional Design Specifications**

The pond shall be divided into two roughly equal volume cells by a permeable divider that will reduce turbulence while allowing movement of water between cells. The divider shall be at least one-half the height of the riser and a minimum of one foot below the top of the riser. Wire-backed, 2- to 3-foot high, extra strength filter fabric supported by treated 4"x4"s can be used as a divider. Alternatively, staked straw bales wrapped with filter fabric (geotextile) may be used. If the pond is more than 6 feet deep, a different mechanism must be proposed. A riprap embankment is one acceptable method of

separation for deeper ponds. Other designs that satisfy the intent of this provision are allowed as long as the divider is permeable, structurally sound, and designed to prevent erosion under or around the barrier.

To aid in determining sediment depth, one-foot intervals shall be prominently marked on the riser.

If an embankment of more than 6 feet is proposed, the pond must comply with the criteria contained in Volume III regarding dam safety for detention BMPs.

- The most common structural failure of sedimentation basins is caused by piping. Piping refers to two phenomena: (1) water seeping through fine-grained soil, eroding the soil grain by grain and forming pipes or tunnels; and, (2) water under pressure flowing upward through a granular soil with a head of sufficient magnitude to cause soil grains to lose contact and capability for support.

The most critical construction sequences to prevent piping will be:

1. Tight connections between riser and barrel and other pipe connections.
2. Adequate anchoring of riser.
3. Proper soil compaction of the embankment and riser footing.
4. Proper construction of anti-seep devices.

Maintenance Standards

- Sediment shall be removed from the pond when it reaches 1-foot in depth.
- Any damage to the pond embankments or slopes shall be repaired.

BMP C250: Construction Stormwater Chemical Treatment

Purpose

This BMP applies when using stormwater chemicals in batch treatment or flow-through treatment.

Turbidity is difficult to control once fine particles are suspended in stormwater runoff from a construction site. Sedimentation ponds are effective at removing larger particulate matter by gravity settling, but are ineffective at removing smaller particulates such as clay and fine silt. Traditional erosion and sediment control BMPs may not be adequate to ensure compliance with the water quality standards for turbidity in receiving water.

Chemical treatment can reliably provide exceptional reductions of turbidity and associated pollutants. Chemical treatment may be required to meet turbidity stormwater discharge requirements, especially when construction is to proceed through the wet season.

Conditions of Use

Formal written approval from Ecology is required for the use of chemical treatment regardless of site size. The Local Permitting Authority may also

***Design and
Installation
Specifications***

require review and approval. When approved, the chemical treatment systems must be included in the Construction Stormwater Pollution Prevention Plan (SWPPP).

See [Appendix II-B](#) for background information on chemical treatment.

Criteria for Chemical Treatment Product Use: Chemically treated stormwater discharged from construction sites must be nontoxic to aquatic organisms. The Chemical Technology Assessment Protocol (CTAPE) must be used to evaluate chemicals proposed for stormwater treatment. Only chemicals approved by Ecology under the CTAPE may be used for stormwater treatment. The approved chemicals, their allowable application techniques (batch treatment or flow-through treatment), allowable application rates, and conditions of use can be found at the Department of Ecology Emerging Technologies website: <http://www.ecy.wa.gov/programs/wq/stormwater/newtech/technologies.html>.

Treatment System Design Considerations: The design and operation of a chemical treatment system should take into consideration the factors that determine optimum, cost-effective performance. It is important to recognize the following:

- Only Ecology approved chemicals may be used and must follow approved dose rate.
- The pH of the stormwater must be in the proper range for the polymers to be effective, which is typically 6.5 to 8.5
- The coagulant must be mixed rapidly into the water to ensure proper dispersion.
- A flocculation step is important to increase the rate of settling, to produce the lowest turbidity, and to keep the dosage rate as low as possible.
- Too little energy input into the water during the flocculation phase results in flocs that are too small and/or insufficiently dense. Too much energy can rapidly destroy floc as it is formed.
- Care must be taken in the design of the withdrawal system to minimize outflow velocities and to prevent floc discharge. Discharge from a batch treatment system should be directed through a physical filter such as a vegetated swale that would catch any unintended floc discharge. Currently, flow-through systems always discharge through the chemically enhanced sand filtration system.
- System discharge rates must take into account downstream conveyance integrity.

Polymer Batch Treatment Process Description:

A batch chemical treatment system consists of the stormwater collection system (either temporary diversion or the permanent site drainage system), a storage pond, pumps, a chemical feed system, treatment cells, and interconnecting piping.

The batch treatment system shall use a minimum of two lined treatment cells in addition to an untreated stormwater storage pond. Multiple treatment cells allow for clarification of treated water while other cells are being filled or emptied. Treatment cells may be ponds or tanks. Ponds with constructed earthen embankments greater than six feet high or which impound more than 10 acre-feet require special engineering analyses. The Ecology Dam Safety Section has specific design criteria for dams in Washington State (see <http://www.ecy.wa.gov/programs/wr/dams/GuidanceDocs.html>).

Stormwater is collected at interception point(s) on the site and is diverted by gravity or by pumping to an untreated stormwater storage pond or other untreated stormwater holding area. The stormwater is stored until treatment occurs. It is important that the holding pond be large enough to provide adequate storage.

The first step in the treatment sequence is to check the pH of the stormwater in the untreated stormwater storage pond. The pH is adjusted by the application of carbon dioxide or a base until the stormwater in the storage pond is within the desired pH range, 6.5 to 8.5. When used, carbon dioxide is added immediately downstream of the transfer pump. Typically sodium bicarbonate (baking soda) is used as a base, although other bases may be used. When needed, base is added directly to the untreated stormwater storage pond. The stormwater is recirculated with the treatment pump to provide mixing in the storage pond. Initial pH adjustments should be based on daily bench tests. Further pH adjustments can be made at any point in the process.

Once the stormwater is within the desired pH range (dependant on polymer being used), the stormwater is pumped from the untreated stormwater storage pond to a treatment cell as polymer is added. The polymer is added upstream of the pump to facilitate rapid mixing.

After polymer addition, the water is kept in a lined treatment cell for clarification of the sediment-floc. In a batch mode process, clarification typically takes from 30 minutes to several hours. Prior to discharge samples are withdrawn for analysis of pH, flocculent chemical concentration, and turbidity. If both are acceptable, the treated water is discharged.

Several configurations have been developed to withdraw treated water from the treatment cell. The original configuration is a device that withdraws the treated water from just beneath the water surface using a

float with adjustable struts that prevent the float from settling on the cell bottom. This reduces the possibility of picking up sediment-floc from the bottom of the pond. The struts are usually set at a minimum clearance of about 12 inches; that is, the float will come within 12 inches of the bottom of the cell. Other systems have used vertical guides or cables which constrain the float, allowing it to drift up and down with the water level. More recent designs have an H-shaped array of pipes, set on the horizontal.

This scheme provides for withdrawal from four points rather than one. This configuration reduces the likelihood of sucking settled solids from the bottom. It also reduces the tendency for a vortex to form. Inlet diffusers, a long floating or fixed pipe with many small holes in it, are also an option.

Safety is a primary concern. Design should consider the hazards associated with operations, such as sampling. Facilities should be designed to reduce slip hazards and drowning. Tanks and ponds should have life rings, ladders, or steps extending from the bottom to the top.

Polymer Batch Treatment Process Description:

At a minimum, a flow-through chemical treatment system consists of the stormwater collection system (either temporary diversion or the permanent site drainage system), an untreated stormwater storage pond, and the chemically enhanced sand filtration system.

Stormwater is collected at interception point(s) on the site and is diverted by gravity or by pumping to an untreated stormwater storage pond or other untreated stormwater holding area. The stormwater is stored until treatment occurs. It is important that the holding pond be large enough to provide adequate storage.

Stormwater is then pumped from the untreated stormwater storage pond to the chemically enhanced sand filtration system where polymer is added. Adjustments to pH may be necessary before chemical addition. The sand filtration system continually monitors the stormwater for turbidity and pH. If the discharge water is ever out of an acceptable range for turbidity or pH, the water is recycled to the untreated stormwater pond where it can be retreated.

For batch treatment and flow-through treatment, the following equipment should be located in a lockable shed:

- The chemical injector.
- Secondary containment for acid, caustic, buffering compound, and treatment chemical.
- Emergency shower and eyewash.
- Monitoring equipment which consists of a pH meter and a turbidimeter.

System Sizing:

Certain sites are required to implement flow control for the developed sites. These sites must also control stormwater release rates during construction. Generally, these are sites that discharge stormwater directly, or indirectly, through a conveyance system, into a fresh water. System sizing is dependent on flow control requirements.

Sizing Criteria for Batch Treatment Systems for Flow Control Exempt Water Bodies:

The total volume of the untreated stormwater storage pond and treatment ponds or tanks must be large enough to treat stormwater that is produced during multiple day storm events. It is recommended that at a minimum the untreated stormwater storage pond be sized to hold 1.5 times the runoff volume of the 10-year, 24-hour storm event. Bypass should be provided around the chemical treatment system to accommodate extreme storm events. Runoff volume shall be calculated using the methods presented in Volume 3, Chapter 2. Worst-case land cover conditions (i.e., producing the most runoff) should be used for analyses (in most cases, this would be the land cover conditions just prior to final landscaping).

Primary settling should be encouraged in the untreated stormwater storage pond. A forebay with access for maintenance may be beneficial.

There are two opposing considerations in sizing the treatment cells. A larger cell is able to treat a larger volume of water each time a batch is processed. However, the larger the cell the longer the time required to empty the cell. A larger cell may also be less effective at flocculation and therefore require a longer settling time. The simplest approach to sizing the treatment cell is to multiply the allowable discharge flow rate times the desired drawdown time. A 4-hour drawdown time allows one batch per cell per 8-hour work period, given 1 hour of flocculation followed by two hours of settling.

If the discharge is directly to a flow control exempt receiving water listed in Appendix I-E of Volume I or to an infiltration system, there is no discharge flow limit.

Ponds sized for flow control water bodies must at a minimum meet the sizing criteria for flow control exempt waters.

Sizing Criteria for Flow-Through Treatment Systems for Flow Control Exempt Water Bodies:

When sizing storage ponds or tanks for flow-through systems for flow control exempt water bodies, the treatment system capacity should be a factor. The untreated stormwater storage pond or tank should be sized to hold 1.5 times the runoff volume of the 10-year, 24-hour storm event minus the treatment system flowrate for an 8-hour period. For a chitosan-enhanced sand filtration system, the treatment system flowrate should be sized using a hydraulic loading rate between 6-8 gpm/ft². Other hydraulic

loading rates may be more appropriate for other systems. Bypass should be provided around the chemical treatment system to accommodate extreme storms. Runoff volume shall be calculated using the methods presented in Volume 3, Chapter 2. Worst-case land cover conditions (i.e., producing the most runoff) should be used for analyses (in most cases, this would be the land cover conditions just prior to final landscaping).

Sizing Criteria for Flow Control Water Bodies:

Sites that must implement flow control for the developed site condition must also control stormwater release rates during construction. Construction site stormwater discharges shall not exceed the discharge durations of the pre-developed condition for the range of pre-developed discharge rates from ½ of the 2-year flow through the 10-year flow as predicted by an approved continuous runoff model. The pre-developed condition to be matched shall be the land cover condition immediately prior to the development project. This restriction on release rates can affect the size of the storage pond and treatment cells.

The following is how WWHM can be used to determine the release rates from the chemical treatment systems:

1. Determine the pre-developed flow durations to be matched by entering the existing land use area under the “Pre-developed” scenario in WWHM. The default flow range is from ½ of the 2-year flow through the 10-year flow.
2. Enter the post developed land use area in the “Developed Unmitigated” scenario in WWHM.
3. Copy the land use information from the “Developed Unmitigated” to “Developed Mitigated” scenario.
4. While in the “Developed Mitigated” scenario, add a pond element under the basin element containing the post-developed land use areas. This pond element represents information on the available untreated stormwater storage and discharge from the chemical treatment system. In cases where the discharge from the chemical treatment system is controlled by a pump, a stage/storage/discharge (SSD) table representing the pond must be generated outside WWHM and imported into WWHM. WWHM can route the runoff from the post-developed condition through this SSD table (the pond) and determine compliance with the flow duration standard. This would be an iterative design procedure where if the initial SSD table proved to be inadequate, the designer would have to modify the SSD table outside WWHM and re-import in WWHM and route the runoff through it again. The iteration will continue until a pond that complies with the flow duration standard is correctly sized.

Notes on SSD table characteristics:

- The pump discharge rate would likely be initially set at just below $\frac{1}{2}$ of the 2-year flow from the pre-developed condition. As runoff coming into the untreated stormwater storage pond increases and the available untreated stormwater storage volume gets used up, it would be necessary to increase the pump discharge rate above $\frac{1}{2}$ of the 2-year. The increase(s) above $\frac{1}{2}$ of the 2-year must be such that they provide some relief to the untreated stormwater storage needs but at the same time will not cause violations of the flow duration standard at the higher flows. The final design SSD table will identify the appropriate pumping rates and the corresponding stage and storages.
 - When building such a flow control system, the design must ensure that any automatic adjustments to the pumping rates will be as a result of changes to the available storage in accordance with the final design SSD table.
5. It should be noted that the above procedures would be used to meet the flow control requirements. The chemical treatment system must be able to meet the runoff treatment requirements. It is likely that the discharge flow rate of $\frac{1}{2}$ of the 2-year or more may exceed the treatment capacity of the system. If that is the case, the untreated stormwater discharge rate(s) (i.e., influent to the treatment system) must be reduced to allow proper treatment. Any reduction in the flows would likely result in the need for a larger untreated stormwater storage volume.

If the discharge is to a municipal storm drainage system, the allowable discharge rate may be limited by the capacity of the public system. It may be necessary to clean the municipal storm drainage system prior to the start of the discharge to prevent scouring solids from the drainage system. If the municipal storm drainage system discharges to a water body not on the flow control exempt list, the project site is subject to flow control requirements. Obtain permission from the owner of the collection system before discharging to it.

If system design does not allow you to discharge at the slower rates as described above and if the site has a retention or detention pond that will serve the planned development, the discharge from the treatment system may be directed to the permanent retention/detention pond to comply with the flow control requirement. In this case, the untreated stormwater storage pond and treatment system will be sized according to the sizing criteria for flow-through treatment systems for flow control exempt water bodies described earlier except all discharge (water passing through the treatment system and stormwater bypassing the treatment system) will be directed into the permanent retention/detention pond. If site constraints make locating the untreated stormwater storage pond difficult, the permanent retention/detention pond may be divided to serve as the untreated stormwater storage pond and the post-treatment flow control pond. A berm or barrier must be used in this case so the untreated water does not mix with the treated

Maintenance Standards

water. Both untreated stormwater storage requirements, and adequate post-treatment flow control must be achieved. The post-treatment flow control pond's revised dimensions must be entered into the WWHM and the WWHM must be run to confirm compliance with the flow control requirement.

Monitoring: At a minimum, the following monitoring shall be conducted. Test results shall be recorded on a daily log kept on site. Additional testing may be required by the NPDES permit based on site conditions.

Operational Monitoring:

- Total volume treated and discharged.
- Flow must be continuously monitored and recorded at not greater than 15-minute intervals.
- Type and amount of chemical used for pH adjustment.
- Amount of polymer used for treatment.
- Settling time.

Compliance Monitoring:

- Influent and effluent pH, flocculent chemical concentration, and turbidity must be continuously monitored and recorded at not greater than 15-minute intervals. pH and turbidity of the receiving water.

Biomonitoring:

Treated stormwater must be non-toxic to aquatic organisms. Treated stormwater must be tested for aquatic toxicity or residual chemicals. Frequency of biomonitoring will be determined by Ecology.

Residual chemical tests must be approved by Ecology prior to their use.

If testing treated stormwater for aquatic toxicity, you must test for acute (lethal) toxicity. Bioassays shall be conducted by a laboratory accredited by Ecology, unless otherwise approved by Ecology. Acute toxicity tests shall be conducted per the CTAPE protocol.

Discharge Compliance: Prior to discharge, treated stormwater must be sampled and tested for compliance with pH, flocculent chemical concentration, and turbidity limits. These limits may be established by the Construction Stormwater General Permit or a site-specific discharge permit. Sampling and testing for other pollutants may also be necessary at some sites. pH must be within the range of 6.5 to 8.5 standard units and not cause a change in the pH of the receiving water of more than 0.2 standard units. Treated stormwater samples and measurements shall be taken from the discharge pipe or another location representative of the nature of the treated stormwater discharge. Samples used for determining compliance with the water quality standards in the receiving water shall not be taken from the treatment pond prior to decanting. Compliance with the water quality standards is determined in the receiving water.

Operator Training: Each contractor who intends to use chemical treatment shall be trained by an experienced contractor . Each site using chemical treatment must have an operator trained and certified by an organization approved by Ecology.

Standard BMPs: Surface stabilization BMPs should be implemented on site to prevent significant erosion. All sites shall use a truck wheel wash to prevent tracking of sediment off site.

Sediment Removal and Disposal:

- Sediment shall be removed from the storage or treatment cells as necessary. Typically, sediment removal is required at least once during a wet season and at the decommissioning of the cells. Sediment remaining in the cells between batches may enhance the settling process and reduce the required chemical dosage.
- Sediment that is known to be non-toxic may be incorporated into the site away from drainages.

BMP C251: Construction Stormwater Filtration

Purpose

Filtration removes sediment from runoff originating from disturbed areas of the site.

Background Information:

Filtration with sand media has been used for over a century to treat water and wastewater. The use of sand filtration for treatment of stormwater has developed recently, generally to treat runoff from streets, parking lots, and residential areas. The application of filtration to construction stormwater treatment is currently under development.

Conditions of Use

Traditional BMPs used to control soil erosion and sediment loss from sites under development may not be adequate to ensure compliance with the water quality standard for turbidity in the receiving water. Filtration may be used in conjunction with gravity settling to remove sediment as small as fine silt (0.5 µm). The reduction in turbidity will be dependent on the particle size distribution of the sediment in the stormwater. In some circumstances, sedimentation and filtration may achieve compliance with the water quality standard for turbidity.

The use of construction stormwater filtration does not require approval from Ecology as long as treatment chemicals are not used. Filtration in conjunction with polymer treatment requires testing under the Chemical Technology Assessment Protocol – Ecology (CTAPE) before it can be initiated. Approval from the appropriate regional Ecology office must be obtained at each site where polymers use is proposed prior to use. For more guidance on stormwater chemical treatment see [BMP C250](#).

***Design and
Installation
Specifications***

Two types of filtration systems may be applied to construction stormwater treatment: rapid and slow. Rapid sand filters are the typical system used for water and wastewater treatment. They can achieve relatively high hydraulic flow rates, on the order of 2 to 20 gpm/sf, because they have automatic backwash systems to remove accumulated solids. In contrast, slow sand filters have very low hydraulic rates, on the order of 0.02 gpm/sf, because they do not have backwash systems. Slow sand filtration has generally been used to treat stormwater. Slow sand filtration is mechanically simple in comparison to rapid sand filtration but requires a much larger filter area.

Filtration Equipment. Sand media filters are available with automatic backwashing features that can filter to 50 μm particle size. Screen or bag filters can filter down to 5 μm . Fiber wound filters can remove particles down to 0.5 μm . Filters should be sequenced from the largest to the smallest pore opening. Sediment removal efficiency will be related to particle size distribution in the stormwater.

Treatment Process Description. Stormwater is collected at interception point(s) on the site and is diverted to an untreated stormwater sediment pond or tank for removal of large sediment and storage of the stormwater before it is treated by the filtration system. The untreated stormwater is pumped from the trap, pond, or tank through the filtration system in a rapid sand filtration system. Slow sand filtration systems are designed as flow through systems using gravity.

***Maintenance
Standards***

Rapid sand filters typically have automatic backwash systems that are triggered by a pre-set pressure drop across the filter. If the backwash water volume is not large or substantially more turbid than the untreated stormwater stored in the holding pond or tank, backwash return to the untreated stormwater pond or tank may be appropriate. However, other means of treatment and disposal may be necessary.

- Screen, bag, and fiber filters must be cleaned and/or replaced when they become clogged.
- Sediment shall be removed from the storage and/or treatment ponds as necessary. Typically, sediment removal is required once or twice during a wet season and at the decommissioning of the ponds.

Sizing Criteria for Flow-Through Treatment Systems for Flow Control Exempt Water Bodies:

When sizing storage ponds or tanks for flow-through systems for flow control exempt water bodies the treatment system capacity should be a factor. The untreated stormwater storage pond or tank should be sized to hold 1.5 times the runoff volume of the 10-year, 24-hour storm event minus the treatment system flowrate for an 8-hour period. For a chitosan-enhanced sand filtration system, the treatment system flowrate should be sized using a hydraulic loading rate between 6-8 gpm/ft². Other hydraulic

loading rates may be more appropriate for other systems. Bypass should be provided around the chemical treatment system to accommodate extreme storms. Runoff volume shall be calculated using the methods presented in Volume 3, Chapter 2. Worst-case conditions (i.e., producing the most runoff) should be used for analyses (most likely conditions present prior to final landscaping).

Sizing Criteria for Flow Control Water Bodies:

Sites that must implement flow control for the developed site condition must also control stormwater release rates during construction. Construction site stormwater discharges shall not exceed the discharge durations of the pre-developed condition for the range of pre-developed discharge rates from 1/2 of the 2-year flow through the 10-year flow as predicted by an approved continuous runoff model. The pre-developed condition to be matched shall be the land cover condition immediately prior to the development project. This restriction on release rates can affect the size of the storage pond, the filtration system, and the flow rate through the filter system.

The following is how WWHM can be used to determine the release rates from the filtration systems:

1. Determine the pre-developed flow durations to be matched by entering the land use area under the “Pre-developed” scenario in WWHM. The default flow range is from 1/2 of the 2-year flow through the 10-year flow.
2. Enter the post developed land use area in the “Developed Unmitigated” scenario in WWHM.
3. Copy the land use information from the “Developed Unmitigated” to “Developed Mitigated” scenario.
4. There are two possible ways to model stormwater filtration systems:
 - a. The stormwater filtration system uses an untreated stormwater storage pond/tank and the discharge from this pond/tank is pumped to one or more filters. In-line filtration chemicals would be added to the flow right after the pond/tank and before the filter(s). Because the discharge is pumped, WWHM can't generate a stage/storage /discharge (SSD) table for this system. This system is modeled the same way as described in [BMP C250](#) and is as follows:

While in the “Developed Mitigated” scenario, add a pond element under the basin element containing the post-developed land use areas. This pond element represents information on the available untreated stormwater storage and discharge from the filtration system. In cases where the discharge from the filtration system is controlled by a pump, a stage/storage/discharge (SSD) table representing the pond must be generated outside WWHM and

imported into WWHM. WWHM can route the runoff from the post-developed condition through this SSD table (the pond) and determine compliance with the flow duration standard. This would be an iterative design procedure where if the initial SSD table proved to be out of compliance, the designer would have to modify the SSD table outside WWHM and re-import in WWHM and route the runoff through it again. The iteration will continue until a pond that enables compliance with the flow duration standard is designed.

Notes on SSD table characteristics:

- The pump discharge rate would likely be initially set at just below $\frac{1}{2}$ of the 2-year flow from the pre-developed condition. As runoff coming into the untreated stormwater storage pond increases and the available untreated stormwater storage volume gets used up, it would be necessary to increase the pump discharge rate above $\frac{1}{2}$ of the 2-year. The increase(s) above $\frac{1}{2}$ of the 2-year must be such that they provide some relief to the untreated stormwater storage needs but at the same time they will not cause violations of the flow duration standard at the higher flows. The final design SSD table will identify the appropriate pumping rates and the corresponding stage and storages.
 - When building such a flow control system, the design must ensure that any automatic adjustments to the pumping rates will be as a result of changes to the available storage in accordance with the final design SSD table.
- b. The stormwater filtration system uses a storage pond/tank and the discharge from this pond/tank gravity flows to the filter. This is usually a slow sand filter system and it is possible to model it in WWHM as a Filter element or as a combination of Pond and Filter element placed in series. The stage/storage/discharge table(s) may then be generated within WWHM as follows:
- (i) While in the “Developed Mitigated” scenario, add a Filter element under the basin element containing the post-developed land use areas. The length and width of this filter element would have to be the same as the bottom length and width of the upstream untreated stormwater storage pond/tank.
 - (ii) In cases where the length and width of the filter is not the same as those for the bottom of the upstream untreated stormwater storage tank/pond, the treatment system may be modeled as a Pond element followed by a Filter element. By having these two elements, WWHM would then generate a SSD table for the storage pond which then gravity flows to the Filter element. The Filter element downstream of the untreated stormwater

storage pond would have a storage component through the media, and an overflow component for when the filtration capacity is exceeded.

WWHM can route the runoff from the post-developed condition through the treatment systems in 4b and determine compliance with the flow duration standard. This would be an iterative design procedure where if the initial sizing estimates for the treatment system proved to be inadequate, the designer would have to modify the system and route the runoff through it again. The iteration would continue until compliance with the flow duration standard is achieved.

5. It should be noted that the above procedures would be used to meet the flow control requirements. The filtration system must be able to meet the runoff treatment requirements. It is likely that the discharge flow rate of $\frac{1}{2}$ of the 2-year or more may exceed the treatment capacity of the system. If that is the case, the untreated stormwater discharge rate(s) (i.e., influent to the treatment system) must be reduced to allow proper treatment. Any reduction in the flows would likely result in the need for a larger untreated stormwater storage volume.

If system design does not allow you to discharge at the slower rates as described above and if the site has a retention or detention pond that will serve the planned development, the discharge from the treatment system may be directed to the permanent retention/detention pond to comply with the flow control requirements. In this case, the untreated stormwater storage pond and treatment system will be sized according to the sizing criteria for flow-through treatment systems for flow control exempt waterbodies described earlier except all discharges (water passing through the treatment system and stormwater bypassing the treatment system) will be directed into the permanent retention/detention pond. If site constraints make locating the untreated stormwater storage pond difficult, the permanent retention/detention pond may be divided to serve as the untreated stormwater discharge pond and the post-treatment flow control pond. A berm or barrier must be used in this case so the untreated water does not mix with the treated water. Both untreated stormwater storage requirements, and adequate post-treatment flow control must be achieved. The post-treatment flow control pond's revised dimensions must be entered into the WWHM and the WWHM must be run to confirm compliance with the flow control requirement.

BMP C252: High pH Neutralization Using CO₂

Purpose

When pH levels in stormwater rise above 8.5 it is necessary to lower the pH levels to the acceptable range of 6.5 to 8.5, this process is called pH neutralization. pH neutralization involves the use of solid or compressed carbon dioxide gas in water requiring neutralization. Neutralized stormwater may be discharged to surface waters under the General Construction NPDES permit.

Neutralized process water such as concrete truck wash-out, hydro-demolition, or saw-cutting slurry must be managed to prevent discharge to surface waters. Any stormwater contaminated during concrete work is considered process wastewater and must not be discharged to surface waters.

Reason for pH Neutralization:

A pH level range of 6.5 to 8.5 is typical for most natural watercourses, and this neutral pH is required for the survival of aquatic organisms. Should the pH rise or drop out of this range, fish and other aquatic organisms may become stressed and may die.

Calcium hardness can contribute to high pH values and cause toxicity that is associated with high pH conditions. A high level of calcium hardness in waters of the state is not allowed.

The water quality standard for pH in Washington State is in the range of 6.5 to 8.5. Ground water standard for calcium and other dissolved solids in Washington State is less than 500 mg/l.

Conditions of Use

Causes of High pH:

High pH at construction sites is most commonly caused by the contact of stormwater with poured or recycled concrete, cement, mortars, and other Portland cement or lime containing construction materials. (See [BMP C151: Concrete Handling](#) for more information on concrete handling procedures). The principal caustic agent in cement is calcium hydroxide (free lime).

Advantages of CO₂ Sparging:

- Rapidly neutralizes high pH water.
- Cost effective and safer to handle than acid compounds.
- CO₂ is self-buffering. It is difficult to overdose and create harmfully low pH levels.
- Material is readily available.

***Design and
Installation
Specifications***

The Chemical Process:

When carbon dioxide (CO₂) is added to water (H₂O), carbonic acid (H₂CO₃) is formed which can further dissociate into a proton (H⁺) and a bicarbonate anion (HCO₃⁻) as shown below:



The free proton is a weak acid that can lower the pH. Water temperature has an effect on the reaction as well. The colder the water temperature is the slower the reaction occurs and the warmer the water temperature is the quicker the reaction occurs. Most construction applications in Washington State have water temperatures in the 50°F or higher range so the reaction is almost simultaneous.

Treatment Process:

High pH water may be treated using continuous treatment, continuous discharge systems. These manufactured systems continuously monitor influent and effluent pH to ensure that pH values are within an acceptable range before being discharged. All systems must have fail safe automatic shut off switches in the event that pH is not within the acceptable discharge range. Only trained operators may operate manufactured systems. System manufacturers often provide trained operators or training on their devices.

The following procedure may be used when not using a continuous discharge system:

1. Prior to treatment, the appropriate jurisdiction should be notified in accordance with the regulations set by the jurisdiction.
2. Every effort should be made to isolate the potential high pH water in order to treat it separately from other stormwater on-site.
3. Water should be stored in an acceptable storage facility, detention pond, or containment cell prior to treatment.
4. Transfer water to be treated to the treatment structure. Ensure that treatment structure size is sufficient to hold the amount of water that is to be treated. Do not fill tank completely, allow at least 2 feet of freeboard.
5. The operator samples the water for pH and notes the clarity of the water. As a rule of thumb, less CO₂ is necessary for clearer water. This information should be recorded.
6. In the pH adjustment structure, add CO₂ until the pH falls in the range of 6.9-7.1. Remember that pH water quality standards apply so adjusting pH to within 0.2 pH units of receiving water (background pH) is recommended. It is unlikely that pH can be adjusted to within 0.2 pH units using dry ice. Compressed carbon dioxide gas should be introduced to the water using a carbon dioxide diffuser located near

the bottom of the tank, this will allow carbon dioxide to bubble up through the water and diffuse more evenly.

7. Slowly discharge the water making sure water does not get stirred up in the process. Release about 80% of the water from the structure leaving any sludge behind.
8. Discharge treated water through a pond or drainage system.
9. Excess sludge needs to be disposed of properly as concrete waste. If several batches of water are undergoing pH treatment, sludge can be left in treatment structure for the next batch treatment. Dispose of sludge when it fills 50% of tank volume.

Sites that must implement flow control for the developed site must also control stormwater release rates during construction. All treated stormwater must go through a flow control facility before being released to surface waters which require flow control.

Maintenance Standards

Safety and Materials Handling:

- All equipment should be handled in accordance with OSHA rules and regulations.
- Follow manufacturer guidelines for materials handling.

Operator Records:

Each operator should provide:

- A diagram of the monitoring and treatment equipment.
- A description of the pumping rates and capacity the treatment equipment is capable of treating.

Each operator should keep a written record of the following:

- Client name and phone number.
- Date of treatment.
- Weather conditions.
- Project name and location.
- Volume of water treated.
- pH of untreated water.
- Amount of CO₂ needed to adjust water to a pH range of 6.9-7.1.
- pH of treated water.
- Discharge point location and description.

A copy of this record should be given to the client/contractor who should retain the record for three years.

Appendix C – Alternative BMPs

The following includes a list of possible alternative BMPs for each of the 14 elements not described in the main SWPPP text. This list can be referenced in the event a BMP for a specific element is not functioning as designed and an alternative BMP needs to be implemented.

Element #3 - Control Flow Rates

BMP C235: Wattles

Element #4 - Install Sediment Controls

BMP C231: Brush Barrier

BMP C232: Gravel Filter Berm

BMP C234: Vegetated Strip

BMP C235: Wattles

Advanced BMPs:

Element #5 - Stabilize Soils

BMP C122: Nets and Blankets

BMP C124: Sodding

BMP C125: Topsoiling/Composting

BMP C126: Polyacrylamide for Soil Erosion Protecting

BMP C130: Surface Roughening

BMP C131: Gradient Terraces

Element #6 - Protect Slopes

BMP C130: Surface Roughening

BMP C131: Gradient Terraces

BMP C203: Water Bars

BMP C204: Pipe Slope Drains

BMP C205: Subsurface Drains

BMP C206: Level Spreader

BMP C208: Triangular Silt Dike (Geotextile-Encased Check Dam)

Element #8 - Stabilize Channels and Outlets

BMP C122: Nets and Blankets

Element #10 - Control Dewatering

BMP C203: Water Bars

BMP C236: Vegetative Filtration

Appendix D – General Permit

To be added by contractor prior to construction.

Appendix E – Site Inspection Forms (and Site Log)

The results of each inspection shall be summarized in an inspection report or checklist that is entered into or attached to the site log book. It is suggested that the inspection report or checklist be included in this appendix to keep monitoring and inspection information in one document, but this is optional; however, it is mandatory that this SWPPP and the site inspection forms be kept onsite at all times during construction, and that inspections be performed and documented as outlined below.

At a minimum, each inspection report or checklist shall include:

- a. Inspection date/times
- b. Weather information: general conditions during inspection, approximate amount of precipitation since the last inspection, and approximate amount of precipitation within the last 24 hours.
- c. A summary or list of all BMPs that have been implemented, including observations of all erosion/sediment control structures or practices.
- d. The following shall be noted:
 - i. locations of BMPs inspected,
 - ii. locations of BMPs that need maintenance,
 - iii. the reason maintenance is needed,
 - iv. locations of BMPs that failed to operate as designed or intended, and
 - v. locations where additional or different BMPs are needed, and the reason(s) why
- e. A description of stormwater discharged from the site. The presence of suspended sediment, turbid water, discoloration, and/or oil sheen shall be noted, as applicable.
- f. A description of any water quality monitoring performed during inspection, and the results of that monitoring.
- g. General comments and notes, including a brief description of any BMP repairs, maintenance, or installations made as a result of the inspection.
- h. A statement that, in the judgment of the person conducting the site inspection, the site is either in compliance or out of compliance with the terms and conditions of the SWPPP and the NPDES permit. If the site inspection indicates that the site is out of compliance, the inspection report shall include a summary of the remedial actions required to bring the site back into compliance, as well as a schedule of implementation.
- i. Name, title, and signature of person conducting the site inspection; and the following statement: "I certify under penalty of law that this report is true, accurate, and complete, to the best of my knowledge and belief".

When the site inspection indicates that the site is not in compliance with any terms and conditions of the NPDES permit, the Permittee shall take immediate action(s) to: stop, contain, and clean up the unauthorized discharges, or otherwise stop the noncompliance; correct the

problem(s); implement appropriate Best Management Practices (BMPs), and/or conduct maintenance of existing BMPs; and achieve compliance with all applicable standards and permit conditions. In addition, if the noncompliance causes a threat to human health or the environment, the Permittee shall comply with the Noncompliance Notification requirements in Special Condition S5.F of the permit.

Site Inspection Form

General Information

Project Name:	Wesley Homes Puyallup		
Inspector Name:	TBD	Title:	
		CESCL # :	
Date:		Time:	
Inspection Type:	<input type="checkbox"/> After a rain event <input type="checkbox"/> Weekly <input type="checkbox"/> Turbidity/transparency benchmark exceedance <input type="checkbox"/> Other		

Weather

Precipitation	Since last inspection	In last 24 hours
----------------------	-----------------------	------------------

Description of General Site Conditions:

Inspection of BMPs

Element 1: Mark Clearing Limits

BMP:

Location	Inspected		Functioning			Problem/Corrective Action
	Y	N	Y	N	NIP	

BMP:

Location	Inspected		Functioning			Problem/Corrective Action
	Y	N	Y	N	NIP	

Element 2: Establish Construction Access

BMP:

Location	Inspected		Functioning			Problem/Corrective Action
	Y	N	Y	N	NIP	

BMP:

Location	Inspected		Functioning			Problem/Corrective Action
	Y	N	Y	N	NIP	

Element 3: Control Flow Rates

BMP:

Location	Inspected		Functioning			Problem/Corrective Action
	Y	N	Y	N	NIP	

BMP:

Location	Inspected		Functioning			Problem/Corrective Action
	Y	N	Y	N	NIP	

Element 4: Install Sediment Controls

BMP:

Location	Inspected		Functioning			Problem/Corrective Action
	Y	N	Y	N	NIP	

BMP:

Location	Inspected		Functioning			Problem/Corrective Action
	Y	N	Y	N	NIP	

BMP:

Location	Inspected		Functioning			Problem/Corrective Action
	Y	N	Y	N	NIP	

BMP:

Location	Inspected		Functioning			Problem/Corrective Action
	Y	N	Y	N	NIP	

BMP:

Location	Inspected		Functioning			Problem/Corrective Action
	Y	N	Y	N	NIP	

Element 5: Stabilize Soils

BMP:

Location	Inspected		Functioning			Problem/Corrective Action
	Y	N	Y	N	NIP	

BMP:

Location	Inspected		Functioning			Problem/Corrective Action
	Y	N	Y	N	NIP	

BMP:

Location	Inspected		Functioning			Problem/Corrective Action
	Y	N	Y	N	NIP	

BMP:

Location	Inspected		Functioning			Problem/Corrective Action
	Y	N	Y	N	NIP	

Element 6: Protect Slopes

BMP:

Location	Inspected		Functioning			Problem/Corrective Action
	Y	N	Y	N	NIP	

BMP:

Location	Inspected		Functioning			Problem/Corrective Action
	Y	N	Y	N	NIP	

BMP:

Location	Inspected		Functioning			Problem/Corrective Action
	Y	N	Y	N	NIP	

Element 7: Protect Drain Inlets

BMP:

Location	Inspected		Functioning			Problem/Corrective Action
	Y	N	Y	N	NIP	

BMP:

Location	Inspected		Functioning			Problem/Corrective Action
	Y	N	Y	N	NIP	

BMP:

Location	Inspected		Functioning			Problem/Corrective Action
	Y	N	Y	N	NIP	

Element 8: Stabilize Channels and Outlets

BMP:

Location	Inspected		Functioning			Problem/Corrective Action
	Y	N	Y	N	NIP	

BMP:

Location	Inspected		Functioning			Problem/Corrective Action
	Y	N	Y	N	NIP	

BMP:

Location	Inspected		Functioning			Problem/Corrective Action
	Y	N	Y	N	NIP	

BMP:

Location	Inspected		Functioning			Problem/Corrective Action
	Y	N	Y	N	NIP	

Element 9: Control Pollutants

BMP:

Location	Inspected			Functioning			Problem/Corrective Action
	Y	N		Y	N	NIP	

BMP:

Location	Inspected			Functioning			Problem/Corrective Action
	Y	N		Y	N	NIP	

Element 10: Control Dewatering

BMP:

Location	Inspected			Functioning			Problem/Corrective Action
	Y	N		Y	N	NIP	

BMP:

Location	Inspected			Functioning			Problem/Corrective Action
	Y	N		Y	N	NIP	

BMP:

Location	Inspected			Functioning			Problem/Corrective Action
	Y	N		Y	N	NIP	

Stormwater Discharges From the Site			
Location	Observed?		Problem/Corrective Action
	Y	N	
Turbidity			
Discoloration			
Sheen			
Location			
Turbidity			
Discoloration			
Sheen			

Water Quality Monitoring

Was any water quality monitoring conducted? Yes No

If water quality monitoring was conducted, record results here:

If water quality monitoring indicated turbidity 250 NTU or greater; or transparency 6 cm or less, was Ecology notified by phone within 24 hrs?

Yes No

If Ecology was notified, indicate the date, time, contact name and phone number below:

Date:

Time:

Contact Name:

Phone #:

General Comments and Notes

Include BMP repairs, maintenance, or installations made as a result of the inspection.

Were Photos Taken? Yes No

If photos taken, describe photos below:

APPENDIX B
OPERATION AND MAINTENANCE MANUAL

Access Road/Easement			
Drainage System Feature	Potential Defect	Conditions When Maintenance Is Needed	Minimum Performance Standard
General	Erosion	Soils are bare or eroded.	Erosion repaired and soils have been protected (through seeding/matting/etc.).
	Road Surface	Condition of road surface may lead to erosion of the facility or limit access.	Road repaired, repaved, or resurfaced to restore access.
	Erosion of Ground Surface	Noticeable rills are seen in landscaped areas.	Eroded areas are filled, contoured, and seeded. Affected areas regraded as necessary. Steps have been taken to eliminate source of erosion (dispersing flows, energy dissipation, etc.).
	Trash & Debris / Litter	Litter accumulation exceeds 1 cubic foot per 1,000 square feet.	No trash or debris present.
	Poisonous Plants and Noxious weeds	Any poisonous plants or nuisance vegetation which may constitute a hazard to maintenance personnel or the public. Any evidence of noxious weeds as defined by State or local regulations.	Eradication of Class A weeds as required by State law. Control of other listed weeds as directed by local policy. Apply requirements of adopted IMP plan for use of herbicides.
	Tree Growth and Hazard Trees	Tree growth does not allow maintenance access or interferes with maintenance activity (i.e., slope mowing, silt removal, vacuuming, or equipment movements). If trees are not interfering with access or maintenance, do not remove. If dead, diseased, or dying trees are identified. (Use a certified Arborist to determine health of tree or removal requirements.)	Trees do not hinder maintenance activities. Harvested trees should be recycled into mulch or other beneficial uses (e.g., alders for firewood).
Remove hazard trees.			
		Trees or shrubs that have been blown down or knocked over.	Tree and shrub debris has been removed and disposed of.
	Weeds (Nonpoisonous)	Weeds growing in more than 20% of the landscaped area (trees and shrubs only).	Weeds present in less than 5% of the landscaped area.
	Insects	When insects such as wasps and hornets interfere with maintenance activities.	Insects destroyed or removed from site. Apply insecticides in compliance with adopted IPM Plan.

Catch Basin

A catch basin is an underground concrete structure typically fitted with a slotted grate to collect stormwater runoff and route it through underground pipes. Catch basins can also be used as a junction in a pipe system and may have a solid lid. There are two types.

A Type 1 catch basin is a rectangular box with approximate dimensions of 3'x2'x5'. Type 1 catch basins are utilized when the connected conveyance pipes are less than 18 inches in diameter and the depth from the gate to the bottom of the pipe is less than 5 feet.

A Type 2 catch basin, also commonly referred to as a storm manhole, is listed separately under “Manhole” in this book.

Catch basins typically provide a storage volume (sump) below the outlet pipe to allow sediments and debris to settle out of the stormwater runoff. Some catch basins are also fitted with a spill control device (inverted elbow on outlet pipe) intended to contain large quantities of grease or debris.

Catch basins are frequently associated with all stormwater facilities.

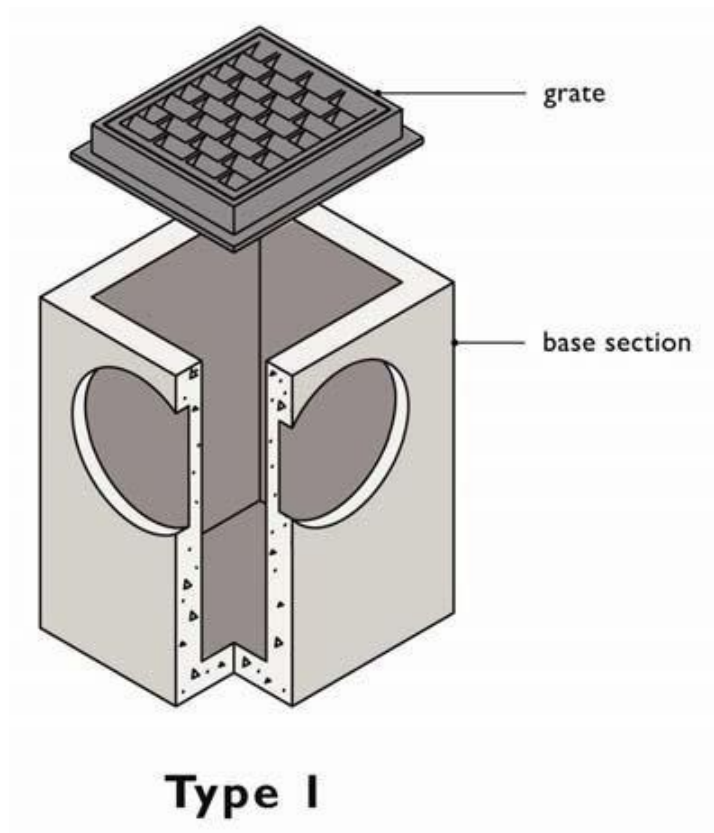

Key Operations and Maintenance Considerations

- The most common tool for cleaning catch basins is an industrial vacuum truck with a tank and vacuum hose (e.g. Vactor® truck) to remove sediment and debris from the sump.
- A catch basin may be an enclosed space where harmful chemicals and vapors can accumulate. Therefore, if the inspection and maintenance requires entering a catch basin, it should be conducted by an individual trained and certified to work in hazardous confined spaces.

Catch Basin			
Drainage System Feature	Potential Defect	Conditions When Maintenance Is Needed	Minimum Performance Standard
Note: table spans multiple pages.			
General	Trash and Debris	Trash or debris which is located immediately in front of the catch basin opening or is blocking inletting capacity of the basin by more than 10%.	No trash or debris located immediately in front of catch basin or on grate opening.
		Trash or debris (in the basin) that exceeds 60 percent of the sump depth as measured from the bottom of basin to invert of the lowest pipe into or out of the basin, but in no case less than a minimum of six inches clearance from the debris surface to the invert of the lowest pipe.	No trash or debris in the catch basin.
		Trash or debris in any inlet or outlet pipe blocking more than 1/3 of its height.	Inlet and outlet pipes free of trash or debris.
		Dead animals or vegetation that could generate odors that could cause complaints or dangerous gases (e.g., methane).	No dead animals or vegetation present within the catch basin.
	Sediment	Sediment (in the basin) that exceeds 60 percent of the sump depth as measured from the bottom of basin to invert of the lowest pipe into or out of the basin, but in no case less than a minimum of 6 inches clearance from the sediment surface to the invert of the lowest pipe.	No sediment in the catch basin.
	Structure Damage to Frame and/or Top Slab	Top slab has holes larger than 2 square inches or cracks wider than 1/4 inch. (Intent is to make sure no material is running into basin.)	Top slab is free of holes and cracks.
		Frame not sitting flush on top slab, i.e., separation of more than 3/4 inch of the frame from the top slab. Frame not securely attached.	Frame is sitting flush on the riser rings or top slab and firmly attached.
	Fractures or Cracks in	Maintenance person judges that structure is unsound.	Basin replaced or repaired to design standards.

	Basin Walls/ Bottom	Grout fillet has separated or cracked wider than 1/2 inch and longer than 1 foot at the joint of any inlet/outlet pipe or any evidence of soil particles entering catch basin through cracks.	Pipe is regouted and secure at basin wall.
	Settlement/ Misalignment	Catch basin has settled more than 1 inch or has rotated more than 2 inches out of alignment.	Basin replaced or repaired to design standards.
	Vegetation Inhibiting System	Vegetation growing across and blocking more than 10% of the basin opening.	No vegetation blocking opening to basin.
		Vegetation growing in inlet/outlet pipe joints that is more than six inches tall and less than six inches apart.	No vegetation or root growth present.
	Contaminants and Pollution	Any evidence of oil, gasoline, contaminants, or other pollutants. Sheen, obvious oil, or other contaminants present. • Identify and remove source	No contaminants or pollutants present.
Catch Basin Cover	Cover Not in Place	Cover is missing or only partially in place. Any open catch basin requires maintenance.	Catch basin cover is closed.
	Locking Mechanism Not Working	Mechanism cannot be opened by one maintenance person with proper tools. Bolts into frame have less than 1/2 inch of thread. One or more bolts are missing.	Mechanism opens with proper tools. All bolts are seated and no bolts are missing. Cover is secure.
	Cover Difficult to Remove	One maintenance person cannot remove lid after applying normal lifting pressure (Intent is to keep cover from sealing off access to maintenance).	Cover can be removed by one maintenance person.
Metal Grates (If Applicable)	Grate Opening Unsafe	Grate with opening wider than 7/8 inch.	Grate opening meets design standards.
	Trash and Debris	Trash and debris that is blocking more than 20% of grate surface inletting capacity.	Grate free of trash and debris.
	Damaged or Missing	Grate missing or broken member(s) of the grate.	Grate is in place and meets design standards.
Oil/Debris Trap (If Applicable)	Dislodged	Oil or debris trap is misaligned with or dislodged from the outlet pipe.	Trap is connected to and aligned with outlet pipe.

Closed Detention System (Tank/Vault)

A closed detention system functions similarly to a detention pond with the temporary storage volume provided by an underground structure to regulate the storm discharge rate from the site. The structure is typically constructed of large diameter pipe (48 inch diameter or greater) or a concrete box (vault). These systems are typically utilized for sites that do not have space available for an above-ground system and are more commonly associated with commercial sites.

Facility objects that are typically associated with a closed detention system include:

- access road or easement
- control structure/flow restrictor
- conveyance stormwater pipe

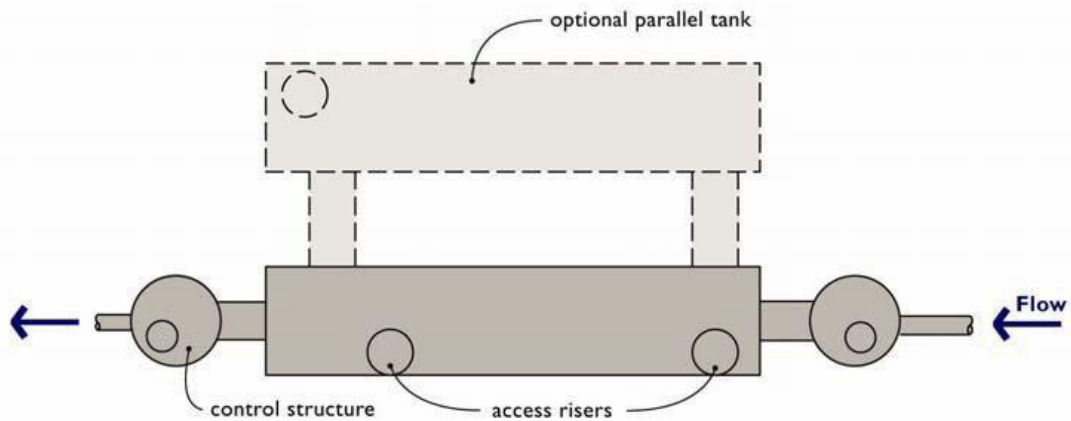

BIRD'S-EYE VIEW

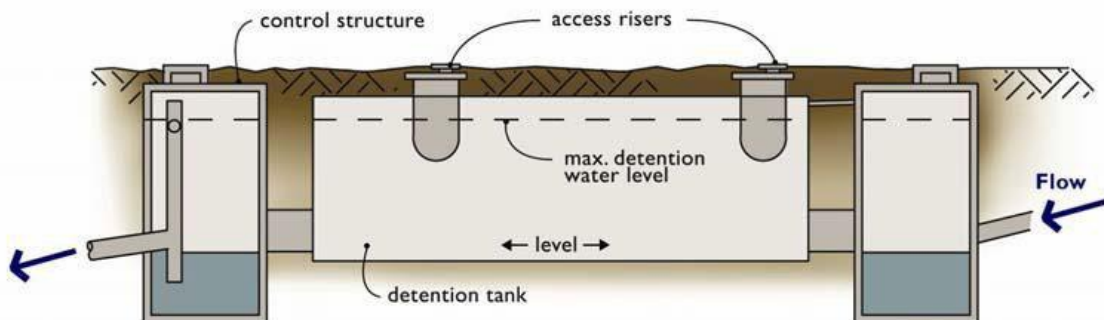

Note:
Closed detention systems will contain water during rainfall events, but should be empty during dry periods.

SIDE PROFILE

Coalescing Plate Oil/Water Separator

A coalescing plate oil/water separator is generally the same as the API type. The main difference is that coalescing plate separators include a series of parallel plates in the separation bay (2nd bay) that increase the oil removal efficiency of the separator.

Facility objects associated with a coalescing plate oil/water separator may include:

- access road or easement
- control structure/flow restrictor
- conveyance stormwater pipe

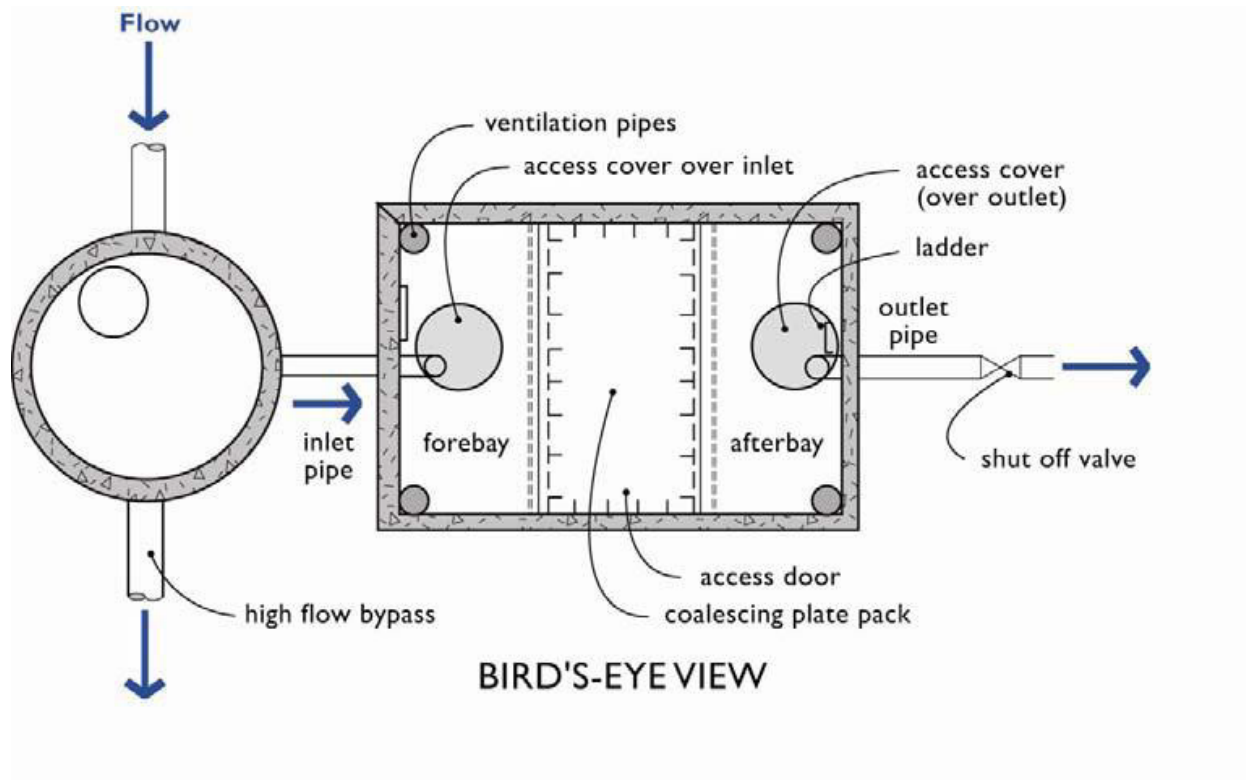

Key Operations and Maintenance Considerations

- Prepare, regularly update, and implement an O&M Manual for the oil/water separators.
- Inspect oil/water separators to ensure proper operation monthly during the wet season of October 1 - April 30 and during and immediately after a large storm event of ≥ 1 inch per 24 hours.
- Clean oil/water separators regularly to keep accumulated oil from escaping during storms. They must be cleaned by October 15 to remove material that has accumulated during the dry season, after all spills, and after a significant storm. Coalescing plates may be cleaned in-situ or after removal from the separator. An eductor truck may be used for oil, sludge, and washwater removal. Replace wash water in the separator with clean water before returning it to service.
- Replace oil absorbent pads before their absorbed oil content reaches capacity.
- Train designated employees on appropriate separator operation, inspection, record keeping, and maintenance procedures.
- Common tools for cleaning and maintaining an oil/water separator are a vacuum truck and/or oil absorbing media materials to remove oils and other sediments that have accumulated in the facility.

Coalescing Plate Oil/Water Separator			
Drainage System Feature	Potential Defect	Conditions When Maintenance Is Needed	Minimum Performance Standard
General	Poor Water Quality	Inspection of discharge water for obvious signs of poor water quality (i.e. obvious oil or other contaminants present).	Effluent discharge from vault clear with no thick visible sheen.
	Sediment Accumulation	Sediment depth in bottom of vault exceeds 6-inches in depth and/or visible signs of sediment on plates.	No sediment deposits on vault bottom and plate media that would impede flow through the vault and reduce separation efficiency.
	Trash and Debris Accumulation	Trash and debris accumulated in vault, or pipe inlet/outlet, floatables and non-floatables.	Vault and inlet/ outlet piping is free of trash and debris.
	Oil Accumulation	Oil accumulation that exceeds 1-inch at the water surface.	Oil has been extracted from vault. Coalescing plates have been cleaned. No visible oil depth on water.
	Damaged Coalescing Plates	Plate media broken, deformed, cracked and/or showing signs of failure.	A portion of the media pack or the entire plate pack has been replaced (depending on severity of failure).
	Damaged Pipes	Inlet or outlet piping damaged or broken and in need of repair.	Pipe has been repaired and or replaced to design specifications.
	Baffles	Baffles corroding, cracking, warping and/or showing signs of failure as determined by maintenance/inspection person.	Baffles have been repaired or replaced to design specifications.
	Vault Structure Damage – Includes Cracks in Walls, Bottom		Cracks wider than 1/2-inch or evidence of soil particles entering the structure through the cracks, or maintenance/inspection personnel determine that the vault is not structurally sound.
Cracks wider than 1/2-inch at the joint of any inlet/outlet pipe or evidence of soil particles entering through the cracks.			Vault repaired so that no cracks exist wider than 1/4-inch at the joint of the inlet/outlet pipe.
Access Manhole	Cover Not in Place	Cover is missing or only partially in place. Any open manhole requires maintenance.	Manhole is closed.
	Locking Mechanism Not Working	Mechanism cannot be opened by one maintenance person with proper tools. Bolts into frame have less than 1/2 inch of thread (may not apply to self-locking lids).	Mechanism opens with proper tools.
	Cover Difficult to Remove	One maintenance person cannot remove lid after applying normal lifting pressure. Intent is to keep cover from sealing off access to maintenance.	Cover can be removed and reinstalled by one maintenance person.
	Ladder Rungs Unsafe	Ladder is unsafe due to missing rungs, misalignment, not securely attached to structure wall, rust, or cracks.	Ladder meets design specifications. Allows maintenance person safe access.
	Structure Damage to Frame and/or Top Slab		Top slab has holes larger than 2 square inches or cracks wider than 1/4 inch. (Intent is to make sure no material is running into basin.)
Frame not sitting flush on top slab, i.e., separation of more than 3/4 inch of the frame from the top slab. Frame not securely attached.			Frame is sitting flush on the riser rings or top slab and firmly attached.

Coalescing Plate Oil/Water Separator			
Drainage System Feature	Potential Defect	Conditions When Maintenance Is Needed	Minimum Performance Standard
Ventilation Pipes	Plugged	Any obstruction to the ventilation pipes.	Ventilation pipes are clear.
Shutoff Valve	Damaged or inoperable	Shutoff valve cannot be opened or closed.	Shutoff valve operates normally.

Compost-Amended Soil

Naturally occurring (undisturbed) soil and vegetation provide important stormwater functions including: water infiltration; nutrient, sediment, and pollutant adsorption; sediment and pollutant biofiltration; water interflow storage and transmission; and pollutant decomposition.

Compaction from construction can reduce the soil's natural ability to provide these functions. Compost-amended soils are intended to replace these lost functions by establishing a minimum soil quality and depth in the post-development landscape.

Sufficient organic content is a key to soil quality. Soil organic matter can be attained through numerous amendments such as compost, composted woody material, biosolids, and forest product residuals. The full benefits of compost-amended soils are realized when desired soil media depths are maintained and soil compaction is minimized.

Key Operations and Maintenance Considerations

- Replenish soil media as needed (as a result of erosion) and address compacted, poorly draining soils.
- Site uses should protect vegetation and avoid soil compaction. Care should be taken to prevent compaction of soils via vehicular loads and/or excessive foot traffic, especially during wet conditions.
- The table below provides the recommended maintenance frequencies, standards, and procedures for compost-amended soils. The level of routine maintenance required and the frequency of corrective maintenance actions may increase for facilities prone to erosion due to site conditions such as steep slopes or topography tending to concentrate flows.

Compost-Amended Soil			
Drainage System Feature	Potential Defect	Conditions When Maintenance Is Needed	Minimum Performance Standard
Soil Media	Soils Waterlogged or Not Infiltrating	Soils become waterlogged, or otherwise do not appear to be infiltrating.	Soils have been aerated or amended such that infiltration occurs and soils do not remain completely saturated, per design specifications.
	Erosion/Scouring	Areas of potential erosion are visible, such as gullies or scouring.	Any eroded areas have been repaired, and sources of erosion addressed to prevent further soil erosion.
Vegetation	Vegetation in Poor Health	Less than 75% of planted vegetation is healthy with a generally good appearance.	At least 75% of planted vegetation is healthy with generally good appearance. Any conditions found that were deleterious to plant health have been corrected where possible. Routine maintenance schedule has been updated as necessary to ensure continued plant health and satisfactory appearance.
	Poisonous Plants and Noxious Weeds	Any poisonous plants or nuisance vegetation which may constitute a hazard to maintenance personnel or the public. Any evidence of noxious weeds as defined by State or local regulations.	No danger of poisonous vegetation where maintenance personnel or the public might normally be. Eradication of Class A weeds as required by State law. Control of other listed weeds as directed by local policies. Apply requirements of adopted IPM policy for the use of herbicides.
	Other Weeds Present	Other weeds (not listed on City/State noxious weed lists) are present on site.	Weeds have been removed per the routine maintenance schedule, following IPM protocols.

Control Structure/Flow Restrictor

Flow control structures and flow restrictors direct or restrict flow in or out of facility components. Outflow controls on detention facilities are a common example where flow control structures slowly release stormwater at a specific rate. The flow is regulated by a combination of orifices (holes with specifically sized diameters) and weirs (plates with rectangular or “V” shaped notch). Lack of maintenance of the control structure can result in the plugging of an orifice. If these flow controls are damaged, plugged, bypassed, or not working properly, the facility could overtop or release water too quickly.

Control structures have a history of maintenance-related problems and it is imperative to establish a good maintenance program for them to function properly. Sediment typically builds up inside the structure, which blocks or restricts flow to the outlet. To prevent this problem, routinely clean out these structures and conduct regular inspections to detect the need for non-routine cleanout.

Facility objects that are typically associated with a control structure/flow restrictor include:

- detention ponds
- media cartridge filters
- closed detention system
- conveyance stormwater pipe

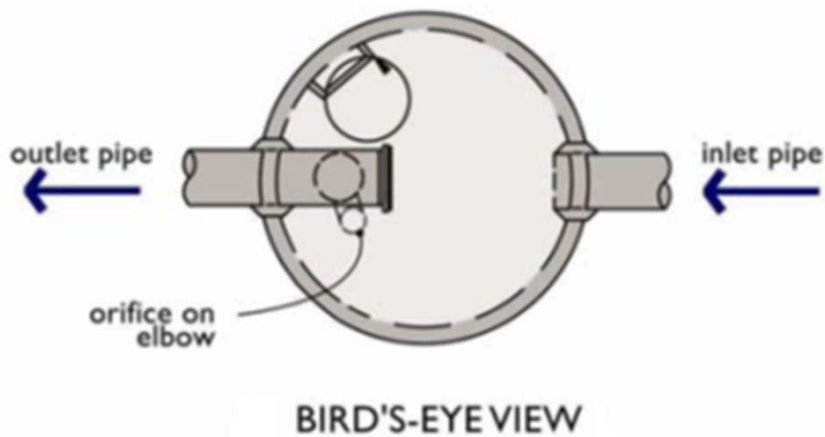

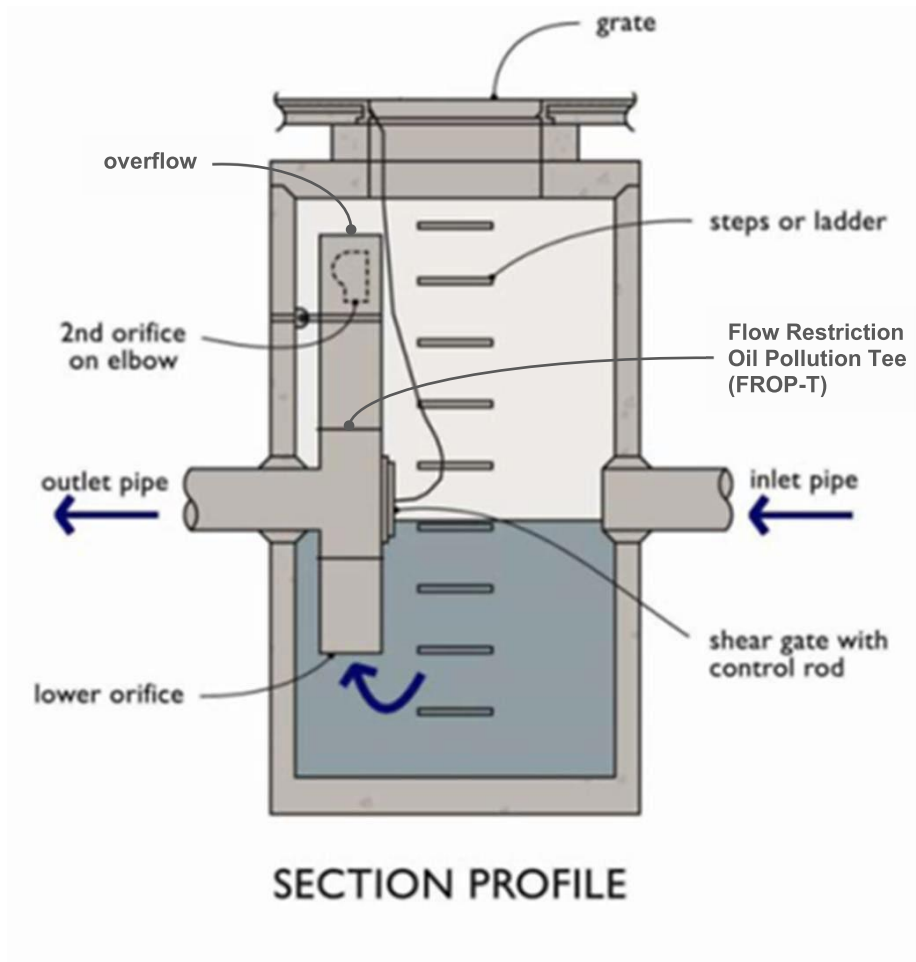

Key Operations and Maintenance Considerations

- Conduct regular inspections of control structures to detect the need for non-routine cleanout, especially if construction or land-disturbing activities occur in the contributing drainage area.
- The most common tool for cleaning control structures/flow restrictors is a truck with a tank and vacuum hose (Vactor® truck) to remove sediment and debris from the sump.
- A control structure is an enclosed space where harmful chemicals and vapors can accumulate. Therefore, if the inspection and maintenance requires entering a control structure, it should be conducted by an individual trained and certified to work in hazardous confined spaces.

Control Structure/Flow Restrictor			
Drainage System Feature	Potential Defect	Conditions When Maintenance Is Needed	Minimum Performance Standard
Structure	Trash and debris	Trash or debris of more than ½ cubic foot which is located immediately in front of the structure opening or is blocking capacity of the structure by more than 10%.	No Trash or debris blocking or potentially blocking entrance to structure.
		Trash or debris in the structure that exceeds 1/3 the depth from the bottom of basin to invert the lowest pipe into or out of the basin.	No trash or debris in the structure.
		Deposits of garbage exceeding 1 cubic foot in volume.	No condition present which would attract or support the breeding of insects or rodents.
	Sediment	Sediment exceeds 60% of the depth from the bottom of the structure to the invert of the lowest pipe into or out of the structure or the bottom of the FROP-T section or is within 6 inches of the invert of the lowest pipe into or out of the structure or the bottom of the FROP-T section.	Sump of structure contains no sediment.
	Damage to frame and/or top slab	Top slab has holes larger than 2 square inches or cracks wider than ¼ inch.	Top slab is free of holes and cracks.
		Frame not sitting flush on top slab, i.e., separation of more than ¾ inch of the frame from the top slab.	Frame is sitting flush on top slab.
	Cracks in walls or bottom	Cracks wider than ½ inch and longer than 3 feet, any evidence of soil particles entering structure through cracks, or maintenance person judges that structure is unsound.	Structure is sealed and structurally sound.
		Cracks wider than ½ inch and longer than 1 foot at the joint of any inlet/outlet pipe or any evidence of soil particles entering structure through cracks.	No cracks more than ¼ inch wide at the joint of inlet/outlet pipe.
	Settlement/misalignment	Structure has settled more than 1 inch or has rotated more than 2 inches out of alignment.	Basin replaced or repaired to design standards.
	Damaged pipe joints	Cracks wider than ½-inch at the joint of the inlet/outlet pipes or any evidence of soil entering the structure at the joint of the inlet/outlet pipes.	No cracks more than ¼-inch wide at the joint of inlet/outlet pipes.
Contaminants and pollution	Any evidence of contaminants or pollution such as oil, gasoline, concrete slurries or paint.	Materials removed and disposed of according to applicable regulations. Source control BMPs implemented if appropriate. No contaminants present other than a surface oil film.	
Ladder rungs missing or unsafe	Ladder is unsafe due to missing rungs, misalignment, rust, cracks, or sharp edges.	Ladder meets design standards and allows maintenance person safe access.	
FROP-T Section	Damage	T section is not securely attached to structure wall and outlet pipe structure should support at least 1,000 lbs of up or down pressure.	T section securely attached to wall and outlet pipe.
		Structure is not in upright position (allow up to 10% from plumb).	Structure in correct position.
		Connections to outlet pipe are not watertight or show signs of deteriorated grout.	Connections to outlet pipe are water tight; structure repaired or replaced and works as designed.
		Any holes—other than designed holes—in the structure.	Structure has no holes other than designed holes.
Shear Gate	Damaged or missing	Shear gate is missing.	Replace shear gate.
		Shear gate is not watertight.	Gate is watertight and works as designed.

		Gate cannot be moved up and down by one maintenance person.	Gate moves up and down easily and is watertight.
		Chain/rod leading to gate is missing or damaged.	Chain is in place and works as designed.
Orifice Plate	Damaged or missing	Control device is not working properly due to missing, out of place, or bent orifice plate.	Plate is in place and works as designed.
	Obstructions	Any trash, debris, sediment, or vegetation blocking the plate.	Plate is free of all obstructions and works as designed.
Overflow Pipe	Obstructions	Any trash or debris blocking (or having the potential of blocking) the overflow pipe.	Pipe is free of all obstructions and works as designed.
	Deformed or damaged lip	Lip of overflow pipe is bent or deformed.	Overflow pipe does not allow overflow at an elevation lower than design
Inlet/Outlet Pipe	Damaged	Cracks wider than 1/2-inch at the joint of the inlet/outlet pipes or any evidence of soil entering at the joints of the inlet/outlet pipes.	No cracks more than 1/4-inch wide at the joint of the inlet/outlet pipe.
Metal Grates (If Applicable)	Unsafe grate opening	Grate with opening wider than 7/8 inch.	Grate opening meets design standards.
	Trash and debris	Trash and debris that is blocking more than 20% of grate surface.	Grate free of trash and debris.
	Damaged or missing	Grate missing or broken member(s) of the grate.	Grate is in place and meets design standards.
Manhole Cover/Lid	Cover/lid not in place	Cover/lid is missing or only partially in place. Any open structure requires urgent maintenance.	Cover/lid protects opening to structure.
	Locking mechanism Not Working	Mechanism cannot be opened by one maintenance person with proper tools. Bolts cannot be seated. Self-locking cover/lid does not work.	Mechanism opens with proper tools.
	Cover/lid difficult to Remove	One maintenance person cannot remove cover/lid after applying 80 lbs. of lift.	Cover/lid can be removed and reinstalled by one maintenance person.

Conveyance Pipe

Storm sewer pipes convey stormwater. Inlet and outlet stormwater pipes convey stormwater in, through, and out of stormwater facilities.

Pipes are built from many materials. Pipes are cleaned to remove sediment or blockages when problems are identified. Stormwater pipes must be clear of obstructions and breaks to prevent localized flooding. All stormwater pipes should be in proper working order and free of the possible defects listed below.

Key Operations and Maintenance Considerations

- The most common tool for cleaning stormwater conveyance pipes is a truck with a tank, vacuum hose, and a jet hose (Vactor® truck) to flush sediment and debris from the pipes.

Conveyance Pipe			
Drainage System Feature	Potential Defect	Conditions When Maintenance Is Needed	Minimum Performance Standard
General	Contaminants and Pollution	Any evidence of oil, gasoline, contaminants, or other pollutants. Sheen, obvious oil, or other contaminants present. <ul style="list-style-type: none"> Identify and remove source. 	No contaminants or pollutants present.
	Obstructions, Including Roots	Root enters or deforms pipe, reducing flow.	Roots have been removed from pipe (using mechanical methods; do not put root-dissolving chemicals in storm sewer pipes). If necessary, vegetation over the line removed.
	Sediment and Debris	Sediment depth is greater than 20% of pipe diameter.	Pipe has been cleaned and is free of sediment/ debris. (Upstream debris traps installed where applicable.)
	Debris Barrier or Trash Rack Missing	Stormwater pipes > than 18 inches need debris barrier.	Debris barrier present on all stormwater pipes 18 inches and greater.
	Damage to protective coating or corrosion	Protective coating is damaged; rust or corrosion is weakening the structural integrity of any part of pipe.	Pipe repaired or replaced.
	Damaged	Any dent that decreases the cross section area of pipe by more than 20% or is determined to have weakened structural integrity of the pipe.	Pipe repaired or replaced.

Debris Barrier & Access Barrier (e.g. Trash Rack)

A debris barrier is a bar grate over the open end of a culvert or stormwater conveyance pipe. The intent of a debris barrier is to prevent large materials from entering a closed pipe system. Debris barriers are typically located on the outlet pipe from a detention pond to the control structure. If a debris barrier is not located on an outlet pipe of 18-inch diameter or greater, one should be installed to prevent plugging of the control structure and possible flooding.

An access barrier is installed on a pipe end that is large enough to allow entry. Their function is to prevent debris and unauthorized access into the storm conveyance pipe. Only qualified personnel should attempt to maintain or remove debris from the barrier when water is flowing through the conveyance pipe.

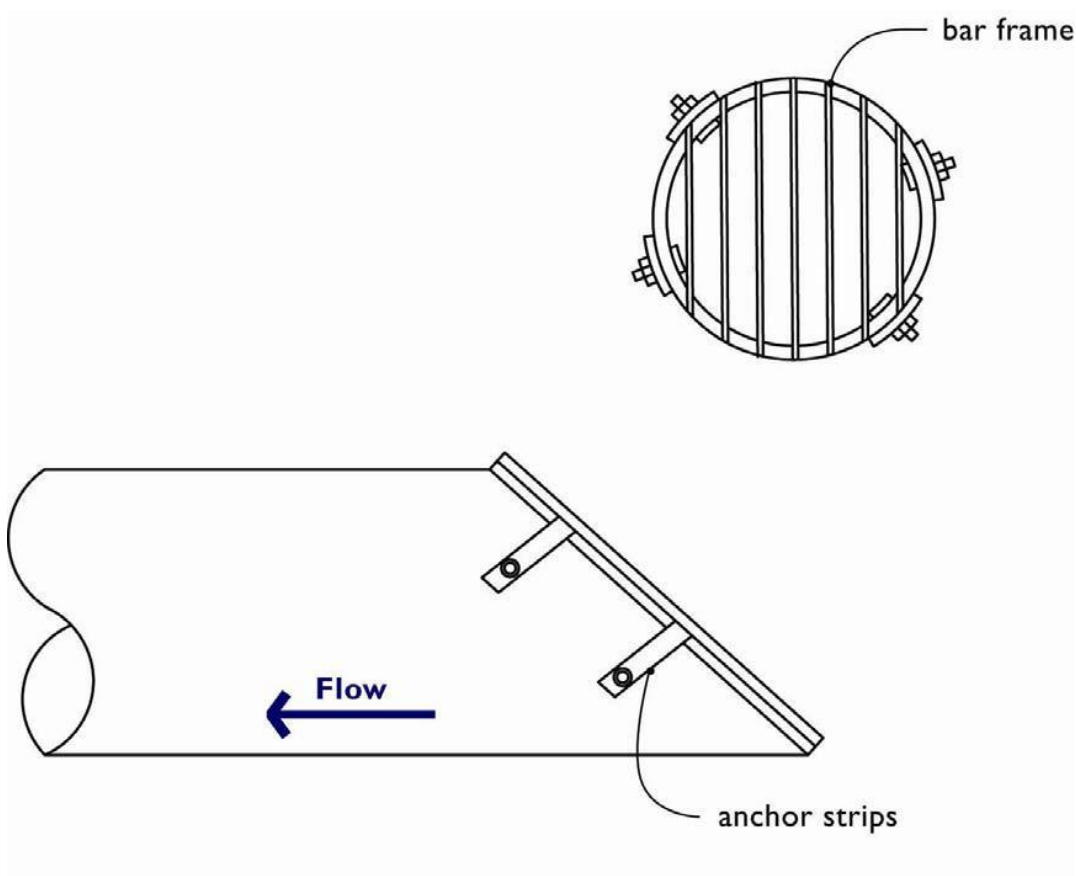

Key Operations and Maintenance Considerations

- The most common tool for cleaning debris and access barriers are hand tools such as a rake to remove collected debris.

Debris Barrier			
Drainage System Feature	Potential Defect	Conditions When Maintenance Is Needed	Minimum Performance Standard
General	Trash and Debris	Trash or debris that is plugging more than 20% of the openings in the barrier.	Barrier cleared to design flow capacity.
	Damaged/ Missing Bars	Bars are bent out of shape more than 3 inches.	Bars in place with no bends more than 3/4 inch.
		Bars are missing or entire barrier missing.	Bars in place according to design specifications.
		Bars are loose and rust is causing 50% deterioration to any part of barrier.	Barrier replaced or repaired to design specifications.
	Missing or Damaged Debris Barrier	Debris barrier missing or not attached to inlet/ outlet pipe.	Barrier is in place and firmly attached to pipe.

Detention Pond

A stormwater detention pond is an open basin built by excavating below existing ground or by constructing above-ground berms (embankments). The detention pond temporarily stores stormwater runoff during rain events and slowly releases it through an outlet (control structure). Detention ponds are typically designed to completely drain within 24 hours after the completion of a storm event.

Facility objects that are typically associated with a detention pond include:

- access road or easement
- fence, gate, and water quality sign
- typical bioswale
- wet bioswale
- media filter cartridge
- control structure/flow restrictor
- energy dissipaters
- conveyance stormwater pipe

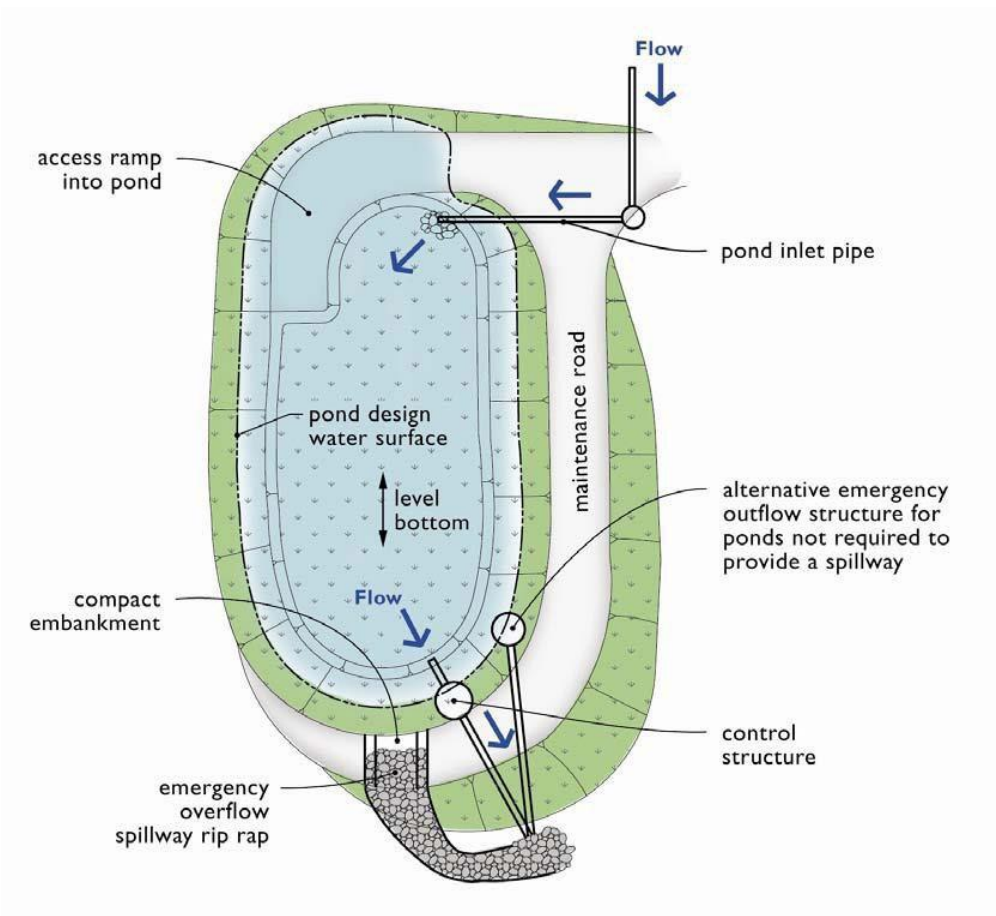

Example of a Manicured Detention Pond

Key Operations and Maintenance Considerations

- Maintenance is of primary importance if detention ponds are to continue to function well.
- Sediment should be removed when the standards in the defect table are exceeded. Sediments must be disposed in accordance with current local health department requirements and the Minimum Functional Standards for Solid Waste Handling.
- Handle sediments removed during the maintenance operation in a manner consistent with the City's recommended street waste procedures.
- Maintenance of sediment forebays and attention to sediment accumulation within the pond is extremely important. Continually monitor sediment deposition in the basin. Owners, operators, and maintenance authorities should be aware that significant concentrations of metals (e.g., lead, zinc, and cadmium) as well as some organics such as pesticides, may be expected to accumulate at the bottom of these types of facilities. Regularly conduct testing sediment, especially near points of inflow, to determine the leaching potential and level of accumulation of potentially hazardous material before disposal.
- Slope areas that have become bare should be revegetated and eroded areas should be regraded prior to being revegetated.
- A common tool for cleaning detention ponds is a small bulldozer or excavator to remove built-up sediment and debris from the bottom of the pond during the dry season.

Refer to City of Puyallup Engineering and Construction Standards Section 600 for grass specifications and planting requirements.

Detention Pond

Drainage System Feature	Potential Defect	Conditions When Maintenance Is Needed	Minimum Performance Standard
Note: table spans multiple pages.			
General	Trash and Debris	<p>Any trash and debris which exceed 1 cubic foot per 1,000 square feet. In general, there should be no visual evidence of dumping.</p> <p>If less than threshold all trash and debris will be removed as part of next scheduled maintenance.</p>	Site is free of trash and debris.
	Poisonous Plants and Noxious Weeds	<p>Any poisonous plants or nuisance vegetation which may constitute a hazard to maintenance personnel or the public.</p> <p>Any evidence of noxious weeds as defined by State or local regulations.</p>	<p>No danger of poisonous vegetation where maintenance personnel or the public might normally be.</p> <p>Eradication of Class A weeds as required by State law. Control of other listed weeds as directed by local policies.</p> <p>Apply requirements of adopted IPM policy for the use of herbicides.</p>
	Vegetation Growth and Hazard Trees	<p>Vegetation growth does not allow maintenance access or interferes with maintenance activity (i.e., slope mowing, silt removal, vacuuming, or equipment movements). If trees are not interfering with access or maintenance, do not remove.</p> <p>Dead, diseased, or dying trees are identified.</p> <p>(Use a certified Arborist to determine health of tree or removal requirements.)</p>	<p>Vegetation does not hinder maintenance activities. Harvested vegetation should be recycled into mulch or other beneficial uses (e.g., alders for firewood).</p> <p>Remove hazard trees.</p>
	Contaminants and Pollution	Any evidence of oil, gasoline, contaminants, or other pollutants. (Coordinate removal/cleanup with local water quality response agency.)	No contaminants or pollutants present.
	Rodent Holes	Any evidence of rodent holes if facility is acting as a dam or berm, or any evidence of water piping through dam or berm via rodent holes.	Rodents destroyed and dam or berm repaired.
	Beaver Dams	Dam results in change or function of the facility.	<p>Facility is returned to design function.</p> <p>(Coordinate trapping of beavers and removal of dams with appropriate permitting agencies.)</p>
	Insects	When insects such as wasps and hornets interfere with maintenance activities.	<p>Insects destroyed or removed from site.</p> <p>Apply insecticides in compliance with adopted IPM Plan.</p>

Side Slopes of Pond	Erosion	Eroded damage over 2 inches deep where cause of damage is still present or where there is potential for continued erosion. Any erosion observed on a compacted berm embankment.	Slopes have been stabilized using appropriate erosion control measure(s); e.g., rock reinforcement, planting of grass, compaction. If erosion is occurring on compacted berms a licensed civil engineer should be consulted to resolve source of erosion.
Storage Area	Sediment	Accumulated sediment that exceeds 10% (typically 6" to 12") of the designed pond depth unless otherwise specified or affects inletting or outletting condition of the facility.	Sediment cleaned out to designed pond shape and depth; pond reseeded if necessary to control erosion.
	Liner (If Applicable)	Liner is visible and has more than three 1/4-inch holes in it.	Liner repaired or replaced. Liner is fully covered.
Pond Berms (Dikes)	Settlements	Any part of berm which has settled 4 inches lower than the design elevation. If settlement is apparent, measure berm to determine amount of settlement. Settling can be an indication of more severe problems with the berm or outlet works. A licensed civil engineer should be consulted to determine the source of the settlement.	Dike is built back to the design elevation.
	Piping	Discernible water flow through pond berm. Ongoing erosion with potential for erosion to continue. (Recommend a Geotechnical engineer be called in to inspect and evaluate condition and recommend repair of condition.	Piping eliminated. Erosion potential resolved.
	Tree Growth	Tree growth on berms over 4 feet in height may lead to piping through the berm which could lead to failure of the berm.	Trees removed. If root system is small (base less than 4 inches) the root system may be left in place. Otherwise the roots should be removed and the berm restored. A licensed civil engineer should be consulted for proper berm/spillway restoration.
	Erosion	Eroded damage over 2 inches deep where cause of damage is still present or where there is potential for continued erosion. Any erosion observed on a compacted berm embankment.	Slopes have been stabilized using appropriate erosion control measure(s); e.g., rock reinforcement, planting of grass, compaction. If erosion is occurring on compacted berms a licensed civil engineer should be consulted to resolve source of erosion.

Emergency Overflow/ Spillway	Tree Growth	Tree growth on emergency spillways creates blockage problems and may cause failure of the berm due to uncontrolled overtopping.	Trees removed. If root system is small (base less than 4 inches) the root system may be left in place. Otherwise the roots should be removed and the berm restored. A licensed civil engineer should be consulted for proper berm/spillway restoration.
	Rock Missing	Only one layer of rock exists above native soil in area five square feet or larger, or any exposure of native soil at the top of flow path of spillway.	Rocks and pad depth are restored to design standards.

Downspout Dispersion Trench

Downspout dispersion trench systems consist of gravel-filled trenches, which serve to spread roof runoff over vegetated pervious areas.

Facility objects that are typically associated with downspout dispersion trench include:

- Dispersion trench: Gravel-filled trenches used to spread stormwater runoff from a downspout drain over a vegetated pervious area. Downspout drains are routed to a trench via a perforated or slotted pipe. The trench typically includes a notched grade board or other device to distribute flow equally along the length of the trench.
- Dispersal area: Stormwater is dispersed to an area vegetated with well-established lawn or pasture, landscaping with well-established groundcover, or native vegetation with natural groundcover. The required vegetated flow path is 50 feet for splash blocks and concentrated dispersion, 25 feet when using a dispersion trench and varies for sheet flow dispersion.

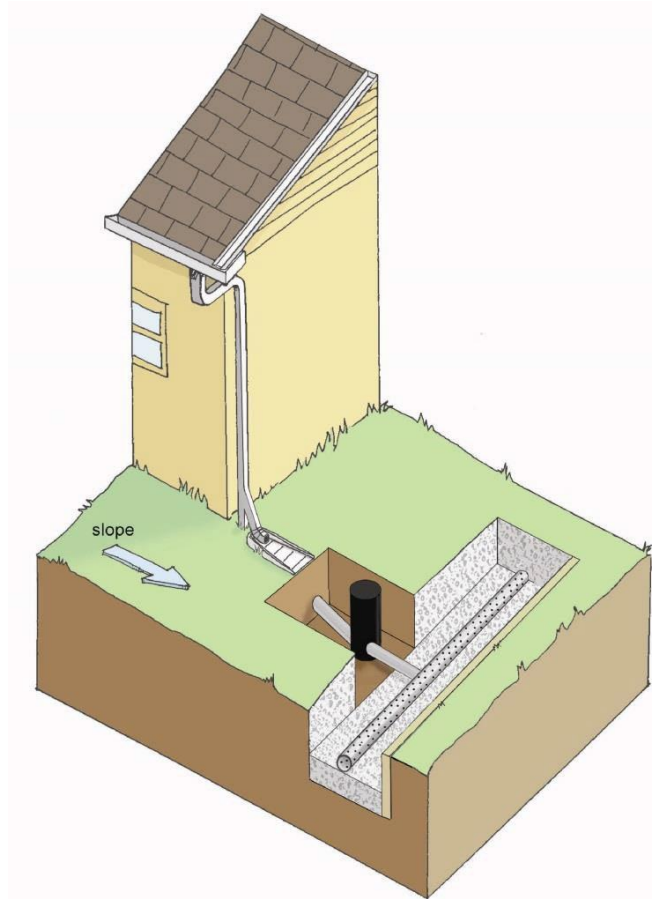

Schematic Downspout Dispersion using Dispersion Trench

Key Operations and Maintenance Considerations

- For dispersion practices to be effective, the dispersion area must remain covered with dense, well-established vegetation. Site uses should protect vegetation and avoid compaction.
- A notched grade board at a dispersion trench must be maintained at a level grade to prevent concentrated flow. Downspout drains are directed to the trench via a storage sump that must be maintained to remove accumulated sediment.
- The groundcover for the extent of the flow in any dispersal area must be maintained to be dense enough to help disperse and infiltrate flows and to prevent erosion.
- The most common tools for cleaning these systems are hand tools to redistribute material disturbed by concentrated flows and a hose to flush downspouts.

Downspout Dispersion Trench			
Drainage System Feature	Potential Defect	Conditions When Maintenance Is Needed	Minimum Performance Standard
Note: table spans multiple pages.			
General	Pests	Signs of pest infestations (IPM protocol threshold(s) are exceeded), including rodent holes or mounds that disturb dispersion flow paths.	Pests are not present or engaged in activities that present a significant public health risk or compromise to the intended design function of the facility. Pests that have exceeded acceptable thresholds have been addressed using appropriate IPM measures.
Dispersion Trench	Concentrated Discharge	Visual evidence of water discharging at concentrated points along trench (normal condition is a "sheet flow" from edge of trench; intent is to prevent erosion damage).	Water is discharging as a sheet flow and any disruptive material (e.g. trash, debris, sediment accumulation) has been removed from trench surface.
	Surface of Trench	Accumulated trash, debris, or sediment on drain rock surface impedes sheet flow from facility. Vegetation/moss present on drain rock surface impedes sheet flow from facility.	Surface of drain rock is free of trash, debris, and sediment accumulation. Rock surface is open, free of vegetation buildup, and drains freely.
	Damage to or Trash/Sediment Accumulation Around Pipes	Accumulation of trash, debris, or sediment in roof drains, gutters, driveway drains, area drains, etc. Pipe from sump to trench or drywell has accumulated sediment or is plugged. Cracked, collapsed, broken, or misaligned drain pipes.	Trash, debris, and sediment is cleared from dispersion trench components (gutters, pipes, etc.). Pipes are free of damage or defects that hinder system from functioning according to design.
Storage Sump	Sediment in Sump	Sediment in the sump.	Sediment not present in sump. Sediment has also been removed from adjacent components (inlet/outlet pipes, etc.) to prevent immediate re-accumulation.
	Access Lid Not Working	Cannot be easily opened; buried; or cover missing.	Access lid present and functioning per design standards.
	Erosion	Erosion of the pond's side slopes and/or scouring of the pond bottom, which exceeds 6-inches, or where continued erosion is prevalent.	Slopes stabilized using proper erosion control measures and repair methods.
Rock Pad	General	Only one layer of rock exists above native soil in area 6 square feet or larger, or any exposure of native soil. Soil erosion in or adjacent to rock pad.	Rock pad has been repaired or replaced to meet design standards.

Downspout Dispersion Trench

Drainage System Feature	Potential Defect	Conditions When Maintenance Is Needed	Minimum Performance Standard
Note: table spans multiple pages.			
Dispersal Area	Erosion or Sediment Accumulation	Erosion (gullies/ rills) greater than 2 inches deep in dispersal area. Accumulated sediment or debris to extent that blocks or channelizes flow path.	Cause of erosion has been eliminated and the damaged area has been repaired and stabilized.
	Standing Water After Storm Event	Standing surface water in dispersion area remains for more than 3 days after the end of a storm event.	Standing water drains within 72 hours of a storm event.
	Transition Zone Erosion and Sizing	Adjacent soil erosion; uneven surface creating concentrated flow discharge; or less than two feet of width.	Transition zone meets design criteria and does not exhibit erosion or other evidence of concentrated flows.
	Poor Vegetation Cover	Poor vegetation cover such that erosion is occurring.	Vegetation has been properly watered and established to meet facility design specifications.
	Excessive Vegetation Cover	Vegetation inhibits dispersed flow along flow path.	Vegetation has been weeded, trimmed, pruned, or thinned to meet facility design criteria.

Energy Dissipater / Outfall Protection

An energy dissipater is installed on or near the inlet or outlet to a closed pipe system to prevent erosion at these locations. There are a variety of designs, including wire gabion baskets, rock splash pads, trenches, and specially designed pools or manholes. The rock splash pad is typically constructed of 4- to 12-inch diameter rocks a minimum of 12 inches thick and is often lined with filter fabric. The rock pad should extend above the top of the pipe a minimum of 1 foot.

Facility features that are typically associated with energy dissipaters include:

- detention ponds
- infiltration basin
- wetponds
- treatment wetlands

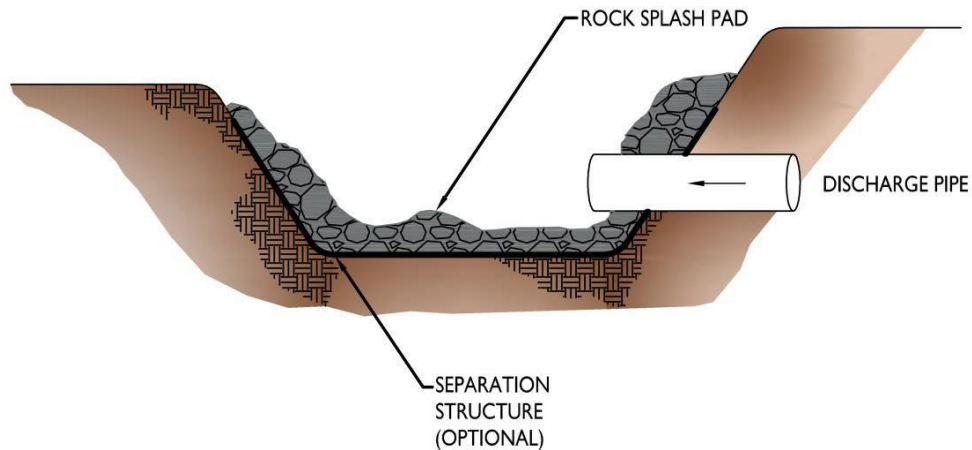

Key Operations and Maintenance Considerations

- The most common tools for maintenance are hand tools such as rakes to redistribute rocks as necessary.
- Periodic removal of sediment or debris may be necessary.

Energy Dissipaters			
Drainage System Feature	Potential Defect	Conditions When Maintenance Is Needed	Minimum Performance Standard
External:			
Rock Pad	Missing or Moved Rock	Only one layer of rock exists above native soil in area five square feet or larger, or any exposure of native soil.	Rock pad has been replaced to design function.
	Erosion	Soil erosion in or adjacent to rock pad.	Rock pad has been replaced to design function.
	Sediment	Sediment on top of rock pad exceeds 10% of the surface.	Rock pad has been cleared of sediment.
	Poisonous Plants and Noxious Weeds	Any poisonous plants or nuisance vegetation which may constitute a hazard to maintenance personnel or the public. Any evidence of noxious weeds as defined by State or local regulations.	No danger of poisonous vegetation where maintenance personnel or the public might normally be. Eradication of Class A weeds as required by State law. Control of other listed weeds as directed by local policies. Apply requirements of adopted IPM policy for the use of herbicides.
	Other Weeds	Other weeds (not listed on State noxious weed lists) are present on the rock pad.	Weeds have been removed per the routine maintenance schedule, following IPM protocols.
Dispersion Trench	Pipe Plugged with Sediment	Accumulated sediment that exceeds 20% of the design depth.	Pipe is free of sediment and meets design specifications.
	Not Discharging Water Properly	Visual evidence of water discharging at concentrated points along trench (normal condition is a "sheet flow" of water along trench). Intent is to prevent erosion damage.	Trench has been repaired or modified such that it does not discharge at concentrated points and meets design function.
	Perforations Plugged	Over 1/2 of perforations in pipe are plugged with debris and sediment.	Perforated pipe has been cleaned or replaced and <25% of perforations are plugged.
	Water Flows Out Top of "Distributor" Catch Basin	Maintenance person observes or receives credible report of water flowing out during any storm less than the design storm or its causing or appears likely to cause damage.	Facility rebuilt per design specifications or redesigned to meet approved City standards.
	Receiving Area Over-Saturated	Water in receiving area is causing or has potential of causing landslide problems.	No danger of landslides.
Gabions	Damaged Mesh	Mesh of gabion broken, twisted or deformed so structure is weakened or rock may fall out.	Mesh is intact, no rock missing.
	Corrosion	Gabion mesh shows corrosion through more than 1/4 of its gage.	All gabion mesh capable of containing rock and retaining designed form.

Energy Dissipaters

Drainage System Feature	Potential Defect	Conditions When Maintenance Is Needed	Minimum Performance Standard
	Collapsed or Deformed Baskets	Gabion basket shape deformed due to any cause.	All gabion baskets intact, structure stands as designed.
	Missing Rock	Any rock missing that could cause gabion to lose structural integrity.	No rock missing.
Internal:			
Manhole/ Chamber	Worn or Damaged Post, Baffles, Side of Chamber	Structure dissipating flow deteriorates to 1/2 of original size or any concentrated worn spot exceeding one square foot which would make structure unsound.	Structure replaced to design standards.

Facility Discharge Points (Outfall)

Stormwater facility discharge points may convey stormwater from the stormwater facility into open channels, ditches, ponds, streams, and wetlands. Stormwater facility discharge points need to be assessed to make sure stormwater is not causing any negative impacts to these drainage areas.

Key Operations and Maintenance Considerations

- The most common tools are hand tools to remove debris or to redistribute outfall protection rock.



(Source: USDA - Natural Resources Conservation Service - Illinois)

Facility Discharge Point (Outfall)			
Drainage System Feature	Potential Defect	Conditions When Maintenance Is Needed	Minimum Performance Standard
Monitoring	Contaminants in Discharge Water	Any evidence of oil, gasoline, contaminants, or other pollutants. Sheen, obvious oil, or other contaminants present. • Identify and remove source.	Effluent discharge from facility is clear.
	Receiving Area Saturated	Water in receiving area is causing substrate to become saturated and unstable.	Receiving area is sound and not saturated.
	Ditch or Stream Banks Eroding (via Off Site Assessment)	Erosion, scouring, or headcuts in ditch or stream banks downstream of facility discharge point due to flow channelization or higher flows.	Ditch or stream banks are stable.
	Access	Vegetation is overgrown and there is no access to the outfall.	Vegetation is removed and/or path is cleared to access the outfall.
	Stains or Deposits	Stains or deposits present within the discharge area that are not natural occurring.	No stains or deposits exist and the source has been eliminated, unless the source is determined to be natural occurring.
	Stormwater Flow	Flow exists during the summer dry months when no flows should be present.	Source of the flows has been eliminated or source has been determined to be groundwater interflow.
General	Missing or Moved Rock	Only one layer of rock exists above native soil in area five square feet or larger, or any exposure of native soil.	Rock pad replaced to design function.
	Erosion	Soil erosion in or adjacent to rock pad.	Rock pad replaced to design function.
	Obstructions, Including Roots	Roots or debris enters pipe or deforms pipe, reducing flow.	Roots have been removed from pipe (using mechanical methods; do not put root-dissolving chemicals in storm sewer pipes). If necessary, vegetation over the line removed.
	Pipe Rusted or Deteriorated	Any part of the pipe that is broken, crushed, or deformed more than 20% or any other failure to the piping.	Pipe repaired or replaced to design standards.

Fencing/Gates/Bollards/Water Quality Sign

Stormwater facilities such as detention ponds or treatment wetlands often have fences to protect them from damage and keep children away from ponds or hazardous areas. Some facilities are required to have informational signs telling the public that the site is a stormwater facility.

Fencing/Gates/Bollards/Water Quality Sign			
Drainage System Feature	Potential Defect	Conditions When Maintenance Is Needed	Minimum Performance Standard
Fencing (Site)	Site erosion or holes under fence	Erosion or holes more than 4 inches high and 12-18 inches wide permitting access through an opening under a fence.	No access under the fence.
Fencing (Wood Posts, Boards, and Cross Members)	Missing or damaged parts	Missing or broken boards, post out of plumb by more than 6 inches or cross members broken	No gaps on fence due to missing or broken boards, post plumb to within 1½ inches, cross members sound.
	Weakened by rotting or insects	Any part showing structural deterioration due to rotting or insect damage	All parts of fence are structurally sound.
	Damaged or failed post foundation	Concrete or metal attachments deteriorated or unable to support posts.	Post foundation capable of supporting posts even in strong wind.
Fencing (Metal Posts, Rails, and Fabric)	Damaged parts	Post out of plumb more than 6 inches.	Post plumb to within 1½ inches.
		Top rails bent more than 6 inches.	Top rail free of bends greater than 1 inch.
		Any part of fence (including post, top rails, and fabric) more than 1 foot out of design alignment.	Fence is aligned and meets design standards.
		Missing or loose tension wire.	Tension wire in place and holding fabric.
	Deteriorated paint or protective coating	Part or parts that have a rusting or scaling condition that has affected structural adequacy.	Structurally adequate posts or parts with a uniform protective coating.
	Openings in fabric	Openings in fabric are such that an 8-inch diameter ball could fit through.	Fabric mesh openings within 50% of grid size.
Chain Link Fencing Gate	Damaged or missing members	Missing gate.	Gates in place.
		Broken or missing hinges such that gate cannot be easily opened and closed by a maintenance person.	Hinges intact and lubed. Gate is working freely.
		Gate is out of plumb more than 6 inches and more than 1 foot out of design alignment.	Gate is aligned and vertical.
		Missing stretcher bar, stretcher bands, and ties.	Stretcher bar, bands, and ties in place.
	Locking mechanism does not lock gate	Locking device missing, non-functioning or does not link to all parts.	Locking mechanism prevents opening of gate.
	Openings in fabric	Openings in fabric are such that an 8-inch diameter ball could fit through.	Fabric mesh openings within 50% of grid size.

Fencing/Gates/Bollards/Water Quality Sign			
Drainage System Feature	Potential Defect	Conditions When Maintenance Is Needed	Minimum Performance Standard
Bollards	Damaged or missing	Bollard broken, missing, does not fit into support hole or hinge broken or missing.	No access for motorized vehicles to get into facility.
	Does not lock	Locking assembly or lock missing or cannot be attached to lock bollard in place.	No access for motorized vehicles to get into facility.
Water Quality Sign	Sign is Damaged or Missing	Water quality sign is leaning more than 8 inches off vertical.	Sign reset to plumb.
		Water quality sign is missing or 20% of the surface is unreadable.	Sign replaced.

Grounds

Grounds (Landscaping)			
Drainage System Feature	Potential Defect	Conditions When Maintenance Is Needed	Minimum Performance Standard
Site	Trash or litter	Any trash and debris which exceed 1 cubic foot per 1,000 square feet (this is about equal to the amount of trash it would take to fill up one standard size office garbage can). In general, there should be no visual evidence of dumping.	Trash and debris cleared from site.
	Noxious weeds	Any noxious or nuisance vegetation which may constitute a hazard to County personnel or the public.	Noxious and nuisance vegetation removed according to applicable regulations. No danger of noxious vegetation where County personnel or the public might normally be.
	Contaminants and pollution	Any evidence of contaminants or pollution such as oil, gasoline, concrete slurries or paint.	Materials removed and disposed of according to applicable regulations. Source control BMPs implemented if appropriate. No contaminants present other than a surface oil film.
	Grass/groundcover	Grass or groundcover exceeds 18 inches in height.	Grass or groundcover mowed to a height no greater than 6 inches.
Trees and Shrubs	Hazard	Any tree or limb of a tree identified as having a potential to fall and cause property damage or threaten human life. A hazard tree identified by a qualified arborist must be removed as soon as possible.	No hazard trees in facility.
	Damaged	Limbs or parts of trees or shrubs that are split or broken which affect more than 25% of the total foliage of the tree or shrub.	Trees and shrubs with less than 5% of total foliage with split or broken limbs.
		Trees or shrubs that have been blown down or knocked over.	No blown down vegetation or knocked over vegetation. Trees or shrubs free of injury.
		Trees or shrubs which are not adequately supported or are leaning over, causing exposure of the roots.	Tree or shrub in place and adequately supported; dead or diseased trees removed.

Manhole

A manhole is an underground concrete structure typically fitted with a slotted grate to collect stormwater runoff and route it through underground pipes. Manholes can also be used as a junction in a pipe system and may have a solid lid. A manhole is also known as a Type 2 catch basin.

Manholes are round concrete structures ranging in diameter from 4 feet to 8 feet. They are used when the connecting conveyance pipe is 18 inches or greater or the depth from grate to pipe bottom exceeds 5 feet. Manholes typically have steps mounted on the side of the structure to allow access.

Manholes typically provide a storage volume (sump) below the outlet pipe to allow sediments and debris to settle out of the stormwater runoff. Some manholes are also fitted with a spill control device (inverted elbow on outlet pipe) intended to contain large quantities of grease or oils.

Manholes are often associated with other stormwater facilities.

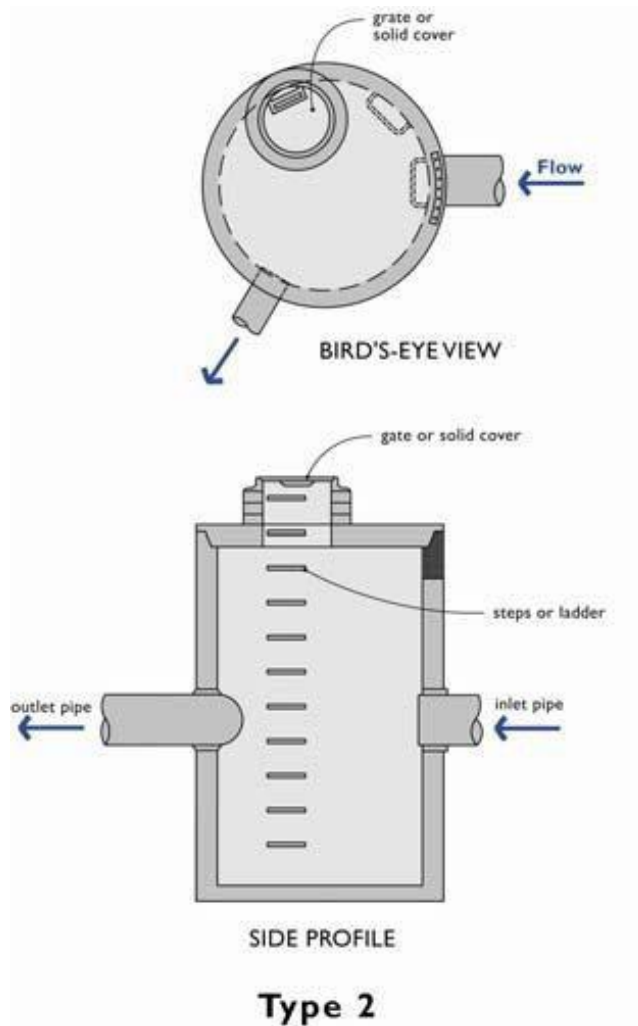

Key Operations and Maintenance Considerations

- The most common tool for cleaning manholes is a truck with a tank and vacuum hose (Vactor® truck) to remove sediment and debris from the sump.
- A manhole may be an enclosed space where harmful chemicals and vapors can accumulate. Therefore, if the inspection and maintenance requires entering a manhole, it should be conducted by an individual trained and certified to work in hazardous confined spaces.

Manhole			
Drainage System Feature	Potential Defect	Conditions When Maintenance Is Needed	Minimum Performance Standard
Note: table spans multiple pages.			
General	Trash and Debris	Trash or debris which is located immediately in front of the opening or is blocking inletting capacity of the basin by more than 10%.	No trash or debris located immediately in front of manhole or on grate opening.
		Trash or debris (in the basin) that exceeds 60 percent of the sump depth as measured from the bottom of basin to invert of the lowest pipe into or out of the basin, but in no case less than a minimum of six inches clearance from the debris surface to the invert of the lowest pipe.	No trash or debris in the basin.
		Trash or debris in any inlet or outlet pipe blocking more than 1/3 of its height.	Inlet and outlet pipes free of trash or debris.
		Dead animals or vegetation that could generate odors that could cause complaints or dangerous gases (e.g., methane).	No dead animals or vegetation present within the catch basin.
	Sediment	Sediment (in the basin) that exceeds 60 percent of the sump depth as measured from the bottom of basin to invert of the lowest pipe into or out of the basin, but in no case less than a minimum of 6 inches clearance from the sediment surface to the invert of the lowest pipe.	No sediment in the basin.
	Structure Damage to Frame and/or Top Slab	Top slab has holes larger than 2 square inches or cracks wider than 1/4 inch. (Intent is to make sure no material is running into manhole.)	Top slab is free of holes and cracks.
		Frame not sitting flush on top slab, i.e., separation of more than 3/4 inch of the frame from the top slab. Frame not securely attached.	Frame is sitting flush on the riser rings or top slab and firmly attached.
	Fractures or Cracks in Basin Walls/ Bottom	Maintenance person judges that structure is unsound.	Basin replaced or repaired to design standards.
		Grout fillet has separated or cracked wider than 1/2 inch and longer than 1 foot at the joint of any inlet/outlet pipe or any evidence of soil particles entering manhole through cracks.	Pipe is regouted and secure at basin wall.

	Settlement/ Misalignment	Manhole has settled more than 1 inch or has rotated more than 2 inches out of alignment.	Manhole replaced or repaired to design standards.
	Vegetation Inhibiting System	Vegetation growing across and blocking more than 10% of the opening.	No vegetation blocking opening to manhole.
		Vegetation growing in inlet/outlet pipe joints that is more than six inches tall and less than six inches apart.	No vegetation or root growth present.
	Contaminants and Pollution	Any evidence of oil, gasoline, contaminants, or other pollutants. Sheen, obvious oil, or other contaminants present. • Identify and remove source.	No contaminants or pollutants present.
Manhole Cover	Cover Not in Place	Cover is missing or only partially in place. Any open manhole is a safety hazard and requires immediate maintenance.	Manhole cover is closed.
	Locking Mechanism Not Working	Mechanism cannot be opened by one maintenance person with proper tools. Bolts into frame have less than 1/2 inch of thread. One or more bolts are missing.	Mechanism opens with proper tools. All bolts are seated and no bolts are missing. Cover is secure.
	Cover Difficult to Remove	One maintenance person cannot remove lid after applying normal lifting pressure (Intent is to keep cover from sealing off access to maintenance).	Cover can be removed by one maintenance person.
Ladder	Ladder Rungs Unsafe	Ladder is unsafe due to missing rungs, not securely attached to manhole wall, misalignment, rust, cracks, or sharp edges.	Ladder meets design standards and allows maintenance person safe access.
Metal Grates (If Applicable)	Grate Opening Unsafe	Grate with opening wider than 7/8 inch.	Grate opening meets design standards.
	Trash and Debris	Trash and debris that is blocking more than 20% of grate surface inletting capacity.	Grate free of trash and debris.
	Damaged or Missing	Grate missing or broken member(s) of the grate.	Grate is in place and meets design standards.

Media Cartridge Filters

Media cartridge filters are passive, flow-through, stormwater treatment systems. They are comprised of one or more vaults that house rechargeable, media-filled filter cartridges. Stormwater passes through a filtering medium, which traps particulates and/or adsorb pollutants such as dissolved metals and hydrocarbons. Once filtered through the media, the treated stormwater is directed to a collection pipe or discharged into an open channel drainage way.

The filter media can be housed in cartridge filters enclosed in concrete vaults or catch basins. Structures will have vault doors or manhole lids (older designs) for maintenance access. Various types of filter media are available from system manufacturers.

StormFilter® units are an example of a proprietary manufactured media cartridge filter system. See manufacturer's publications for additional maintenance information.

Facility objects that are typically associated with a manufactured media filter system include:

- access road or easement
- control structure/flow restrictor
- conveyance stormwater pipe



Media Cartridge Filter Vault with Accumulated Sediment

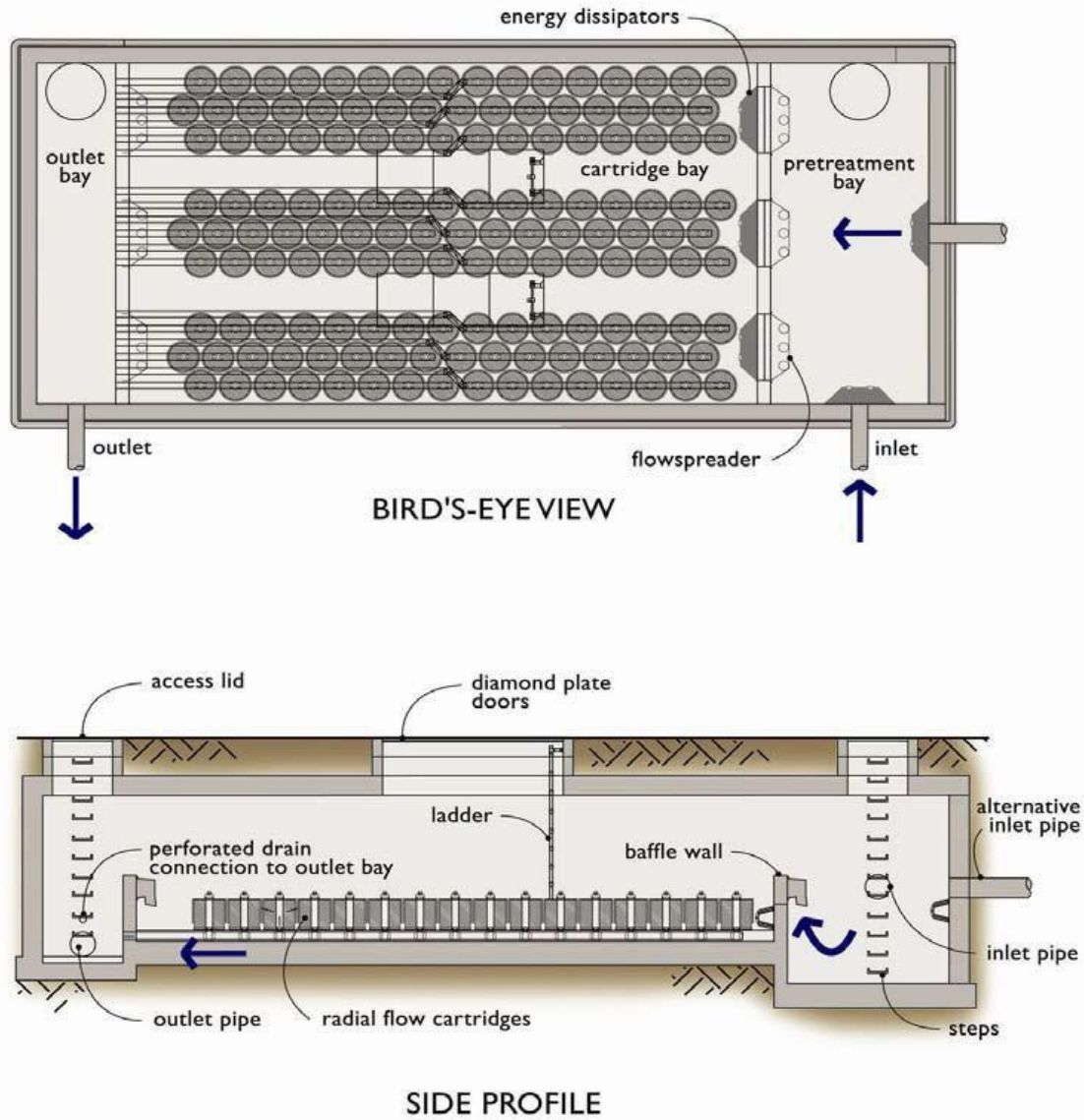

Key Operations and Maintenance Considerations

- The most common tool for cleaning media cartridge filters is a truck with a tank and vacuum hose (e.g. Vactor® truck) to remove sediment and debris from the vault.
- Media cartridge filters are enclosed spaces where harmful chemicals and vapors can accumulate. Therefore, the inspection and maintenance of these facilities should be conducted by an individual trained and certified to work in hazardous confined spaces.
- Cartridges require replacement when the individual cartridges no longer meet the specifications for pollutant removal.

Media Cartridge Filters			
Drainage System Feature	Potential Defect	Conditions When Maintenance Is Needed	Minimum Performance Standard
Note: table spans multiple pages.			
General	Structure Damage to Frame and/or Top Slab	Top slab has holes larger than 2 square inches or cracks wider than 1/4 inch. (Intent is to make sure no material is running into vault.)	Top slab is free of holes and cracks.
		Frame not sitting flush on top slab, i.e., separation of more than 3/4 inch of the frame from the top slab. Frame not securely attached.	Frame is sitting flush on the riser rings or top slab and firmly attached.
Forebay	Sediment Accumulation	Sediment accumulation exceeds 6 inches or 1/3 of available sump.	All sediment removed from storage area.
Media Filter Vault	Sediment Accumulation on Top Media Filters (Cartridges)	Sediment depth exceeds 0.25-inches (on top of filter cartridges).	No sediment deposits which would impede permeability of the compost media. No sediment deposits on top of cartridges. (Sediment on cartridges likely indicates that cartridges are plugged and require maintenance.)
	Sediment Accumulation in Vault	Sediment depth exceeds 4 inches in chamber. Look for other indicators of clogged cartridges or overflow.	No sediment deposits in vault bottom of first chamber. Cartridges have been checked and replaced or serviced as needed.
	Trash and Debris Accumulation	Trash and debris accumulated in vault.	No trash or debris in vault.
	Sediment in Drain Pipes/Clean-Outs	When drain pipes, clean-outs, become full with sediment and/or debris.	Sediment and debris has been removed.
	Damaged Pipes	Any part of the pipes that are crushed or damaged due to corrosion and/or settlement.	Pipe repaired and/or replaced to design specifications.
	Cover/lid not in place	Cover/lid is missing or only partially in place. Any open manhole requires immediate maintenance.	Manhole access covered.
	Locking mechanism not working	Mechanism cannot be opened by one maintenance person with proper tools. Bolts cannot be seated. Self-locking cover/lid does not work.	Mechanism opens with proper tools.
	Cover/lid difficult to remove	One maintenance person cannot remove cover/lid after applying 80 lbs. of lift.	Cover/lid can be removed and reinstalled by one maintenance person.
	Vault Structure Includes Cracks in Wall, Bottom, Damage to	Cracks wider than 1/2 inch or evidence of soil particles entering the structure through the cracks, or maintenance/inspection personnel determine that the vault is not structurally sound.	Vault replaced or repairs made so that vault meets design specifications and is structurally sound.

	Frame and/or Top Slab	Cracks wider than 1/2 inch at the joint of any inlet/outlet pipe or evidence of soil particles entering through the cracks.	Vault repaired so that no cracks exist wider than 1/4 inch at the joint of the inlet/outlet pipe.
	Baffles Damaged	Baffles corroding, cracking, warping, and/or showing signs of failure as determined by maintenance/inspection person.	Baffles repaired or replaced to design specifications.
	Access Ladder Damaged	Ladder is corroded or deteriorated, not functioning properly, not securely attached to structure wall, missing rungs, cracks, and misaligned.	Ladder replaced or repaired and meets design specifications, and is safe to use as determined by inspection personnel.
Below Ground Cartridge Type	Compost Media Clogging	Drawdown of water through the media takes longer than 1 hour, and/or overflow occurs frequently.	Media cartridges have been replaced and drawdown time and overflow frequency are per design standards.
	Short Circuiting	Flows do not properly enter filter cartridges.	Flows are properly entering filter cartridges. Cartridges have been replaced if necessary.
	Filter Cartridges Submerged	Filter vault does not drain within 24 hours following storm. Look for evidence of submergence due to backwater or excessive hydrocarbon loading.	Filter media have been checked and replaced if needed and vault drains down within 24 of a storm event. (If cartridges are plugged with oil, additional treatment or source control BMP may be needed.)

Oil/Water Separator (API Type)

This type of oil/water separator is a design from American Petroleum Institute (API). An oil/water separator is an underground vault that treats stormwater by mechanically separating oil from water. The oil rises to the surface and floats on the water and sediment settles to the bottom. Oil/water separators are typically utilized in locations where high oil concentrations in the stormwater runoff are anticipated (e.g. service and fuel stations). Oil/water separators are most commonly used as the first pretreatment facility in a series of stormwater management facilities.

Facility objects that are typically associated with an oil/water separator include:

- access road or easement
- control structure/flow restrictor

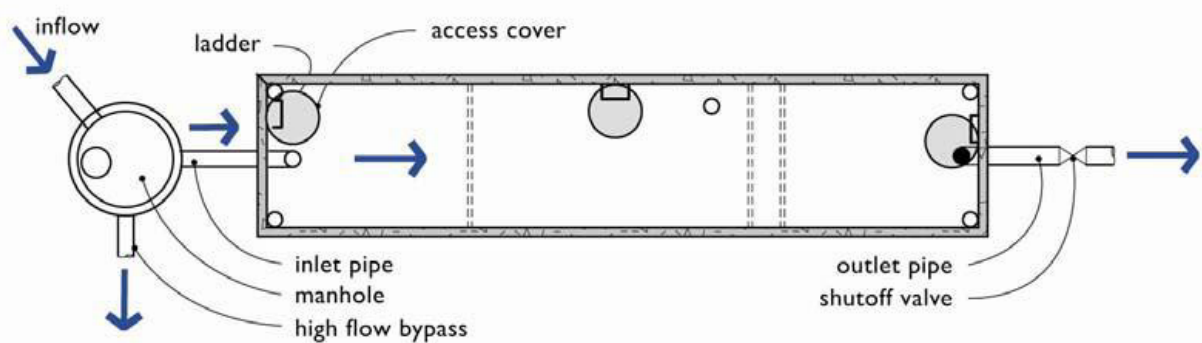

BIRD'S-EYE VIEW

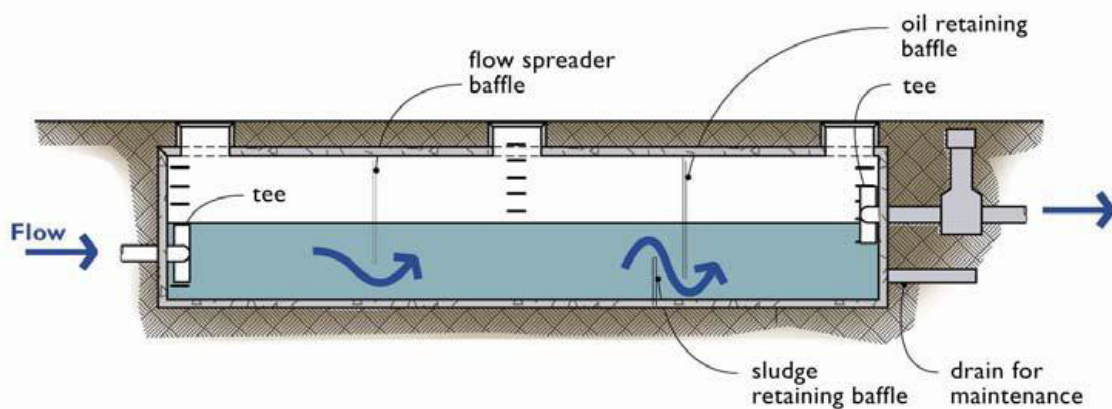

SIDE PROFILE

Key Operations and Maintenance Considerations

- Common tools for cleaning and maintaining an oil/water separator are a vacuum truck and/or oil absorbing media materials to remove oils and other sediments that have accumulated in the facility.
- Prepare, regularly update, and implement an O&M Manual for the oil/water separators.
- Inspect oil/water separators to ensure proper operation monthly during the wet season of October 1 - April 30 and during and immediately after a large storm event of ≥ 1 inch per 24 hours.
- Clean oil/water separators regularly to keep accumulated oil from escaping during storms. They must be cleaned by October 15 to remove material that has accumulated during the dry season, after all spills, and after a significant storm. An eductor truck may be used for oil, sludge, and washwater removal. Replace wash water in the separator with clean water before returning it to service.
- Replace oil absorbent pads before their absorbed oil content reaches capacity.
- Train designated employees on appropriate separator operation, inspection, record keeping, and maintenance procedures.

Oil/Water Separator (API Type)			
Drainage System Feature	Potential Defect	Conditions When Maintenance Is Needed	Minimum Performance Standard
Note: table spans multiple pages.			
General	Poor Water Quality	Inspection of discharge water for obvious signs of poor water quality (i.e. obvious oil or other contaminants present).	Effluent discharge from vault is clear, without thick visible sheen.
	Sediment Accumulation	Sediment depth in bottom of vault exceeds 6-inches in depth.	No sediment deposits on vault bottom that would impede flow through the vault and reduce separation efficiency.
	Trash and Debris Accumulation	Trash and debris accumulation in vault, or pipe inlet/outlet, floatables and non-floatables.	Vault and inlet/outlet piping free of trash and debris.
	Oil Accumulation	Oil accumulations that exceed 1-inch, at the surface of the water.	Oil extracted from vault by vacuuming. Disposal in accordance with state and local rules and regulations.
	Damaged Pipes	Inlet or outlet piping damaged or broken and in need of repair.	Pipe repaired or replaced to design specifications.

Stormwater Treatment, Flow Control, and Conveyance Facility Components

Oil/Water Separator (API Type)			
Drainage System Feature	Potential Defect	Conditions When Maintenance Is Needed	Minimum Performance Standard
Note: table spans multiple pages.			
	Vault Structure Damage – Includes Cracks in Walls Bottom	Maintenance person judges that structure is unsound.	Basin replaced or repaired to design standards.
		Grout fillet has separated or cracked wider than 1/2 inch and longer than 1 foot at the joint of any inlet/outlet pipe or any evidence of soil particles entering catch basin through cracks.	Pipe is regouted and secure at basin wall.
		Cracks wider than 1/2-inch at the joint of any inlet/outlet pipe or evidence of soil particles entering through the cracks.	Vault repaired so that no cracks exist wider than 1/4-inch at the joint of the inlet/outlet pipe.
	Damage to Frame and/or Top Slab	Top slab has holes larger than 2 square inches or cracks wider than 1/4 inch. (Intent is to make sure no material is running into basin.)	Top slab is free of holes and cracks.
		Frame not sitting flush on top slab, i.e., separation of more than 3/4 inch of the frame from the top slab. Frame not securely attached.	Frame is sitting flush on the riser rings or top slab and firmly attached.
	Baffles	Baffles corroding, cracking, warping and/or showing signs of failure as determined by maintenance/inspection person.	Baffles repaired or replaced to design specifications.
Access Manhole	Cover/lid not in place	Cover/lid is missing or only partially in place. Any open manhole requires immediate maintenance.	Manhole access covered.
	Locking mechanism not working	Mechanism cannot be opened by one maintenance person with proper tools. Bolts cannot be seated. Self-locking cover/lid does not work.	Mechanism opens with proper tools.
	Cover/lid difficult to remove	One maintenance person cannot remove cover/lid after applying 80 lbs. of lift.	Cover/lid can be removed and reinstalled by one maintenance person.
	Ladder rungs unsafe	Missing rungs, misalignment, rust, or cracks.	Ladder meets design standards. Allows maintenance person safe access.

Treatment Wetland

A stormwater treatment wetland is a shallow constructed pond that is designed to treat stormwater through the biological processes associated with emergent aquatic plants. These facilities use dense wetland vegetation and settling to filter sediment and oily materials out of stormwater.

Stormwater treatment wetlands are used to capture pollutants in a managed environment so that they will not reach natural wetlands and other ecologically important habitats. Vegetation must occasionally be harvested and sediment dredged in stormwater treatment wetlands. In general, stormwater wetlands perform well to remove sediment, metals, and pollutants that bind to humic or organic acids.

Facility objects that are often associated with a treatment wetland include:

- inlet
- flow control structure
- detention pond
- access road or easement
- fence, gate, and water quality sign
- energy dissipaters (flow spreaders)
- conveyance stormwater pipe



Example Treatment Wetland

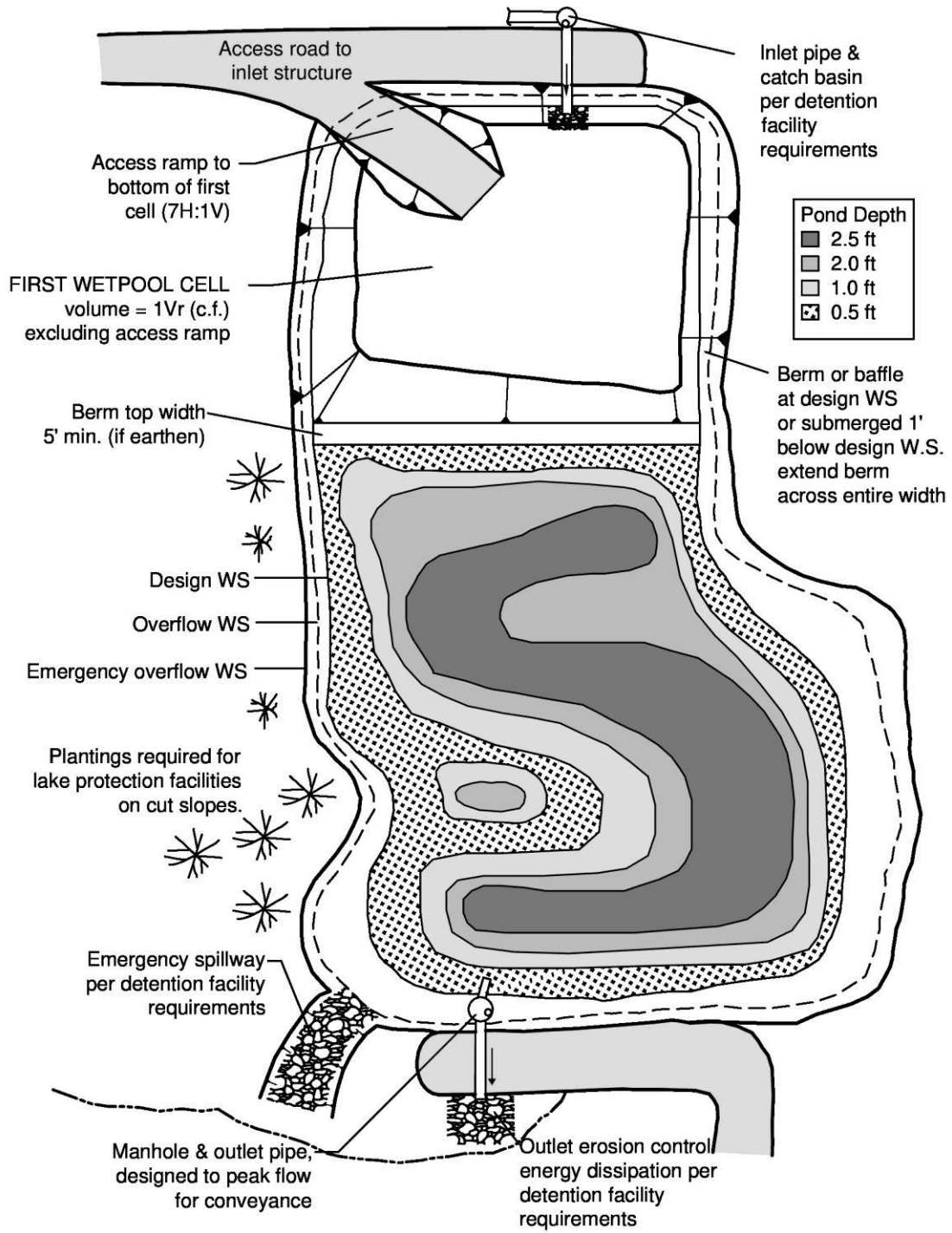

PLAN VIEW Option B
NTS

Key Operations and Maintenance Considerations

- Wetlands should be inspected at least twice per year during the first three years during both growing and non-growing seasons to observe plant species presence, abundance, and condition; bottom contours and water depths relative to plans; and sediment, outlet, and buffer conditions.
- Maintenance should be scheduled around sensitive wildlife and vegetation seasons.
- Plants may require watering, physical support, mulching, weed removal, or replanting during the first three years.
- Nuisance plant species should be removed and desirable species should be replanted.

Treatment Wetland			
Drainage System Feature	Potential Defect	Conditions When Maintenance Is Needed	Minimum Performance Standard
Site	Trash and debris	Trash and debris accumulated on facility site.	Trash and debris removed from facility site.
	Noxious weeds	Any noxious or nuisance vegetation which may constitute a hazard to County personnel or the public.	Noxious and nuisance vegetation removed according to applicable regulations. No danger of noxious vegetation where County personnel or the public might normally be.
	Contaminants and pollution	Any evidence of contaminants or pollution such as oil, gasoline, concrete slurries or paint.	Materials removed and disposed of according to applicable regulations. Source control BMPs implemented if appropriate. No contaminants present other than a surface oil film.
	Grass/ground cover	Grass or groundcover exceeds 18 inches in height.	Grass or groundcover mowed to a height no greater than 6 inches.
Side Slopes of Dam, Berm, internal berm or Embankment	Rodent holes	Any evidence of rodent holes if facility is acting as a dam or berm, or any evidence of water piping through dam or berm via rodent holes.	Rodents removed or destroyed and dam or berm repaired.
	Tree growth	Tree growth threatens integrity of dams, berms or slopes, does not allow maintenance access, or interferes with maintenance activity. If trees are not a threat to dam, berm, or embankment integrity or not interfering with access or maintenance, they do not need to be removed.	Trees do not hinder facility performance or maintenance activities.
	Erosion	Eroded damage over 2 inches deep where cause of damage is still present or where there is potential for continued erosion. Any erosion observed on a compacted slope.	Slopes stabilized using appropriate erosion control measures. If erosion is occurring on compacted slope, a licensed civil engineer should be consulted to resolve source of erosion.

Treatment Wetland			
Drainage System Feature	Potential Defect	Conditions When Maintenance Is Needed	Minimum Performance Standard
Top or Side Slopes of Dam, Berm, internal berm or Embankment	Settlement	Any part of a dam, berm or embankment that has settled 4 inches lower than the design elevation.	Top or side slope restored to design dimensions. If settlement is significant, a licensed civil engineer should be consulted to determine the cause of the settlement.
	Irregular surface on internal berm	Top of berm not uniform and level.	Top of berm graded flat to design elevation.
Pond Areas	Sediment accumulation (first cell/forebay)	Sediment accumulations in pond bottom that exceeds the depth of sediment storage (1 foot) plus 6 inches.	Sediment storage contains no sediment.
	Sediment accumulation (wetland cell)	Accumulated sediment that exceeds 10% of the designed pond depth.	Sediment cleaned out to designed pond shape and depth.
	Liner damaged (If Applicable)	Liner is visible or pond does not hold water as designed.	Liner repaired or replaced.
	Water level (first cell/forebay)	Cell level drops more than 12 inches in any 7-day period.	Cell level drops no more than 12 inches in any 7-day period.
	Water level (wetland cell)	Cell does not retain water for at least 10 months of the year or wetland plants are not surviving.	Water retained at least 10 months of the year or wetland plants are surviving.
	Algae mats (first cell/forebay)	Algae mats develop over more than 10% of the water surface should be removed.	Algae mats removed (usually in the late summer before Fall rains, especially in Sensitive Lake Protection Areas.)
	Vegetation	Vegetation dead, dying, or overgrown (cattails) or not meeting original planting specifications across more than 20% of the entire design vegetated area within the pond.	Plants in wetland cell surviving across 80% or more of the entire design vegetated area within the pond and not interfering with wetland function.
Gravity Drain	Inoperable valve	Valve will not open and close.	Valve opens and closes normally.
	Valve won't seal	Valve does not seal completely.	Valve completely seals closed.
Emergency Overflow Spillway	Tree growth	Tree growth impedes flow or threatens stability of spillway.	Trees removed.
	Rock missing	Only one layer of rock exists above native soil in area five square feet or larger, or any exposure of native soil at the top of out flow path of spillway. Rip-rap on inside slopes need not be replaced.	Spillway restored to design standards.
Inlet/Outlet Pipe	Sediment accumulation	Sediment filling 20% or more of the pipe.	Inlet/outlet pipes clear of sediment.
	Trash and debris	Trash and debris accumulated in inlet/outlet pipes (includes floatables and non-floatables).	No trash or debris in pipes.
	Damaged	Cracks wider than ½-inch at the joint of the inlet/outlet pipes or any evidence of soil entering at the joints of the inlet/outlet pipes.	No cracks more than ¼-inch wide at the joint of the inlet/outlet pipe.

Vegetated Roof

Vegetated roofs (also known as ecoroofs and green roofs) are thin layers of engineered soil and vegetation constructed on top of a conventional roof. Vegetated roofs consist of four basic components: a waterproof membrane, drainage layer, lightweight growth medium, and vegetation. Deeper installations, referred to as **intensive** roofs, are comprised of at least 6 inches of growth media and are planted with groundcovers, grasses, shrubs and sometimes trees. These intensive systems require regular landscape maintenance. Shallower installations, referred to as **extensive** roofs, are comprised of less than 6 inches of growth media and use a planting palette of drought-tolerant, low maintenance groundcovers. The procedures outlined below focus on extensive roof systems, and different procedures for intensive roofs are noted.

Facility elements that are typically associated with vegetated roofs include:

- **Waterproof membrane:** Waterproof membranes are installed on the roof deck below the vegetated roof system. Systems also include a protection layer and root barrier to preserve the integrity of the waterproof membrane. These components are not visible, so inspection is typically not possible unless a leak detection system is installed.
- **Drainage layer:** All vegetated roofs have a drainage component that routes excess water to the roof drain system. Usually this takes the form of a manufactured drain mat or granular drainage media. A separation layer (e.g., filter fabric) is typically installed above the drainage mat or granular drainage media to prevent fine components of the growth media from being washed into the roof drain system. This component is also not visible, so inspection is difficult.
- **Growth media:** Vegetated roofs use a light-weight growth medium with adequate fertility and drainage capacity to support plant growth and allow infiltration and storage of water. In general the media is composed of porous and lightweight mineral aggregates such as pumice, lava rock, expanded shale and expanded slate. The growth media may be covered by a mat (or other erosion control measure) to prevent surface erosion due to rain and wind scour before plants are established.
- **Vegetation:** The plants on vegetated roofs are typically succulents, grass, herbs, and/or wildflowers adapted to the harsh conditions (minimal soils, seasonal drought, high winds, and strong sun exposure) prevalent on rooftops. A wider variety of vegetation types may be used on intensive roofs, but these typically require additional maintenance.
- **Structural drainage elements:** The roof drainage system routes water from the vegetated roof drainage layer to a nearby drainage system. There are also other structural components of a roof that may interface with the vegetated roof (e.g., flashing, roof ventilation points, utilities).
- **Border zone:** This zone forms an area, composed of gravel and devoid of vegetation, around the perimeter of the vegetated roof, typically used as a fire prevention method and to prevent water damage.
- **Gravel stops:** These are sheet metal edges, typically installed outside of the border zone, along the perimeter of the roof to prevent growth medium from blowing or washing off of the roof.

APPENDIX C
PHASE 1 STORMWATER SITE PLAN
2017/06/05

STORMWATER SITE PLAN

Proposed Wesley Homes Puyallup Senior Living Project

Northwest Corner of 10th Street S.E.
and 39th Avenue S.E.
Puyallup, Washington

Prepared for:
Wesley Homes



6/5/2017

November 7, 2016
Revised: January 31, 2017
Revised: April 4, 2017
Revised: June 5, 2017

Our Job No. 16718



CIVIL ENGINEERING, LAND PLANNING, SURVEYING
18215 72ND AVENUE SOUTH KENT, WA 98032 (425) 251-6222 (425) 251-8782 FAX
BRANCH OFFICES ♦ TUMWATER, WA ♦ LONG BEACH, CA ♦ ROSEVILLE, CA ♦ SAN DIEGO, CA
www.barghausen.com

TABLE OF CONTENTS

- 1.0 ANALYSIS OF THE MINIMUM REQUIREMENTS
- 2.0 PROJECT OVERVIEW
- 3.0 EXISTING CONDITIONS SUMMARY
- 4.0 OFF-SITE ANALYSIS REPORT
- 5.0 PERMANENT STORMWATER CONTROL PLAN

APPENDICES

- APPENDIX A CONSTRUCTION STORMWATER POLLUTION PREVENTION PLAN
- APPENDIX B OPERATION AND MAINTENANCE MANUAL

1.0 ANALYSIS OF THE MINIMUM REQUIREMENTS

1.0 ANALYSIS OF THE MINIMUM REQUIREMENTS

This is a new development project and meets the threshold for a new development such that all 10 Minimum Requirements apply to this project site. The following is an explanation of how each Minimum Requirement is met.

Minimum Requirement No. 1: Preparation of Stormwater Site Plan.

Response: This Stormwater Site Plan prepared for the project meets the requirements of Minimum Requirement No. 1.

Minimum Requirement No. 2: Construction Stormwater Pollution Prevention Plan.

Response: A Construction Stormwater Pollution Prevention Plan is located within this Final Stormwater Site Plan prepared for this project site as Appendix A.

Minimum Requirement No. 3: Source Control of Pollution.

Response: Available and reasonable Source Control BMPs will be applied to this project for the type of source control pollution being produced on this project site. At the minimum the trash enclosures will be covered and the parking lot will be swept on a regular basis. In addition, the owner will be educated about the proper use of pesticides and fertilizers on this project site.

Minimum Requirement No. 4: Preservation of Natural Drainage Systems and Outfalls.

Response: This project will continue to discharge to a ditch between the Lowes Home Improvement site and this project site which courses in a northerly direction to Bradley Lake several hundred feet away. This ditch has been modified in the past; however, wetland area, A, C and D, on site will be preserved with this new development and portions of the site runoff will be routed to the wetlands in order to assure that hydrology is maintained. For the Wetlands D and C to the north, hydrology will be maintained through dispersion of runoff from the north building roof. For Wetland A, a flow splitting control structure will route a portion of the detention pond discharge into the wetland. The other portion of the pond discharge will be routed to the Lowe's drainage ditch as it does under existing conditions.

Minimum Requirement No. 5: On-Site Stormwater Management.

Response: This project has a few acres of grassy areas landscaping type land cover in addition to several buildings, drive aisles, and parking lots. The on-site soils consist of fill type material which is not conducive for infiltration and the location of the proposed stormwater pond is negatively impacted by groundwater per the geotechnical report. Wetlands A, C, and D will have the hydrology maintained; however, for the most part this site is not conducive for on-site stormwater management.

Minimum Requirement No. 6: Runoff Treatment.

Response: This project site is proposing a stormwater treatment wetland (BMP T10.30) below live detention storage prior to discharge to the on-site ditch that flows to Bradley Lake. This offers enhanced treatment, as Bradley Lake is a fish bearing lake which requires enhanced water quality treatment. The constructed wetland is allowed to be located under the live storage if the 2-year mitigated discharge rate is less than 3 feet above the static water surface elevation. In this case the 2-year release is 0.11 cfs and this occurs at approximately 3 feet above static water surface elevation per the stage storage table calculated in WWHM 2012. There is an access road to the west of the site that will be treated for water quality by use of a Stormfilter Catchbasin. This has been sized to treat the 91st percentile of storm events through WWHM water quality

calculations before entering the pond, as the outlet of the pipe is near the end of the stormwater treatment wetland and therefore would not be receiving adequate treatment through the pond alone.

Minimum Requirement No. 7: Flow Control.

Response: This project is providing flow control in the form of a detention pond located above a stormwater treatment wetland according to City of Puyallup standards, which has adopted the 2005 Department of Ecology Manual for Western Washington as their criteria setting requirement for detention. This is a duration matching standard and utilizes the 2012 Western Washington Hydrology Model (WWHM).

Minimum Requirement No. 8: Wetlands Protection.

Response: The wetlands will be protected and maintained in perpetuity on this site. Please refer to the Wetland Exhibit as well as the Grading and Storm Drainage Plan that shows how these wetlands will maintain hydrology after development of this project site. A portion of the runoff from the North Building will be routed to Wetlands C and D adjacent to the North Building to maintain the wetland hydrology. A portion of the discharge from the detention pond will be routed to Wetland A in order to maintain wetland hydrology. Runoff routed to the wetlands will be discharged through a dispersion trench for each wetland. A hydroperiod analysis for each wetland can be found in the Wetland Exhibit within section 5.0 of this report.

Minimum Requirement No. 9: Basin/Watershed Planning.

Response: This project site is located in the "State Highway Basin" planning area of the City of Puyallup. No additional requirements are required by that plan.

Minimum Requirement No. 10: Operation and Maintenance.

Response: An Operation and Maintenance Manual is located within this Final Stormwater Site Plan as Appendix B.

2.0 PROJECT OVERVIEW

2.0 PROJECT OVERVIEW

The proposed Wesley Homes Senior Living Project is an approximate 14.36-acre site located within a portion of the Southwest quarter of Section 3, Township 19 North, Range 4 East, Willamette Meridian, City of Puyallup, Pierce County, Washington. More particularly, the site is located on the northwest corner of 10th Street S.E. and 39th Avenue S.E. within the City of Puyallup. Please see the attached Vicinity Map in section 4.0 for an exact depiction of the project site.

With the exception of a minor wetland (Wetland B) located centrally to the project, there are multiple wetland areas on this project site that will be kept intact with this development. In addition, the project site tends to slope in a westerly direction at a fairly constant grade down toward a drainage channel which courses northerly toward Bradley Lake approximately 1/8 mile from the project site. Please refer to the Section 4.0 Off-Site Analysis for the FEMA Map for this project site.

The existing conditions on the site were modeled as till forest even though extensive filling and grading has occurred on the project site in the past. The on-site soils are mapped as Everett and Nielsen, which are gravelly sand and very gravelly sand respectively. Please refer to the Soils Map shown later in this report for the mapping of the on-site soils. However, this project site modeled the existing as till type soils due to the extensive filling that has occurred on the property as indicated in the Soils Report. In addition, due to the high groundwater table (at the location of the pond) and the multiple wetlands located on site, the soils are not as conducive to infiltration as previously thought.

Under developed conditions there are two drainage basins on the project site, one in the north and one in the south. The north basin totals 1.94 acres with 1.75 acres of impervious and the south basin totals 8.91 acres with 4.99 acres of impervious.

The south basin consists of parking, drive aisles, landscaping, building rooftops, and a pond with a wetland adjacent to the pond. The pollution generating impervious surfaced plus the pervious landscaping area will all be treated and detained prior to a portion of the discharge going to Wetland A to maintain the hydroperiod. The runoff not routed to the wetland will be discharged to the Lowe's drainage ditch to the northwest of the site.

For the north basin, a portion of the runoff from the north building rooftop will be routed to Wetlands C and D to maintain the wetland hydrology. A hydroperiod analysis for the areas routed to each wetland can be found in the Wetland Flow Distribution Exhibit in section 5.0 of this report.

The project site discharges to a ditch which is tributary to Bradley Lake, a fish-bearing lake. Therefore, enhanced treatment is required. Enhanced water quality is being provided for this site through a stormwater treatment wetland at the bottom of the detention pond. These facilities are sized based on the WWHM as adopted by the City of Puyallup and developed by the Department of Ecology. Please refer to the later sections of this report for the sizing calculations for this facility.

3.0 EXISTING CONDITIONS SUMMARY

3.0 EXISTING CONDITIONS SUMMARY

Under pre-existing conditions the entire 14.36-acre site was till forest over soils conducive for infiltration. Extensive filling has occurred; however, most of the site still consists of till forest second growth at this time with portions consisting of vacant land and the remaining portions pastureland. The site drains at a constant grade from east to west to a large drainage ditch which courses northerly adjacent to the Lowes Home Improvement warehouse, to Bradley Lake Park. The drainage ditch was previously relocated and reconfigured to its current condition as part of the Lowe's Construction Project in 2010. The ditch was sized to convey tributary flows in accordance with the state highway basin plan developed by Brown and Caldwell for the city. The Lowes Home Improvement warehouse forms the project site western neighbor and the ditch is located between Lowes Home Improvement warehouse and the project site.

The site is shaped like the letter "J" and drains to Bradley Lake a couple hundred feet northward of the project site.

There are two basin areas on the developed site; the northern basin and the southern basin, which are shown as an exhibit within Section 5.0. The existing wetland areas are also shown as an exhibit within Section 5.0. This exhibit shows the tributary areas to the existing wetlands on-site.

The Soil Survey Map shows that the site is mostly Everett gravelly sandy loam with areas of Kitsap silt loam and Neilton gravelly loamy sand. This map is shown as an exhibit in Section 4.0. Further discussion of the soils can be found in the soils report located in Section 5.0.

4.0 OFF-SITE ANALYSIS REPORT

4.0 OFF-SITE ANALYSIS REPORT

As mentioned previously, the site drains almost immediately into a drainage channel adjacent to the west property line of the project site and courses northerly and within 200 to 300 feet discharges into Bradley Lake, a fairly large water body located within the City of Puyallup City Limits. Bradley Lake backwaters into the ditch conveyance system during peak storm events; however, that ditch conveyance system is much lower in elevation than the proposed project site development area and there is no perceptible impact to the development area.

There is no upstream basin contributing runoff to this project site as 39th Avenue S.E. forms the project site's southern boundary and has its own conveyance and collection system. To the east, the area is developed with its own conveyance and collection system. There is approximately 1.01 acres of vegetated land to the east that could drain towards the site. The runoff for the 10-year storm is calculated to be 0.0073 cfs, spanning over 1,282 feet, and would therefore be negligible.

VICINITY MAP

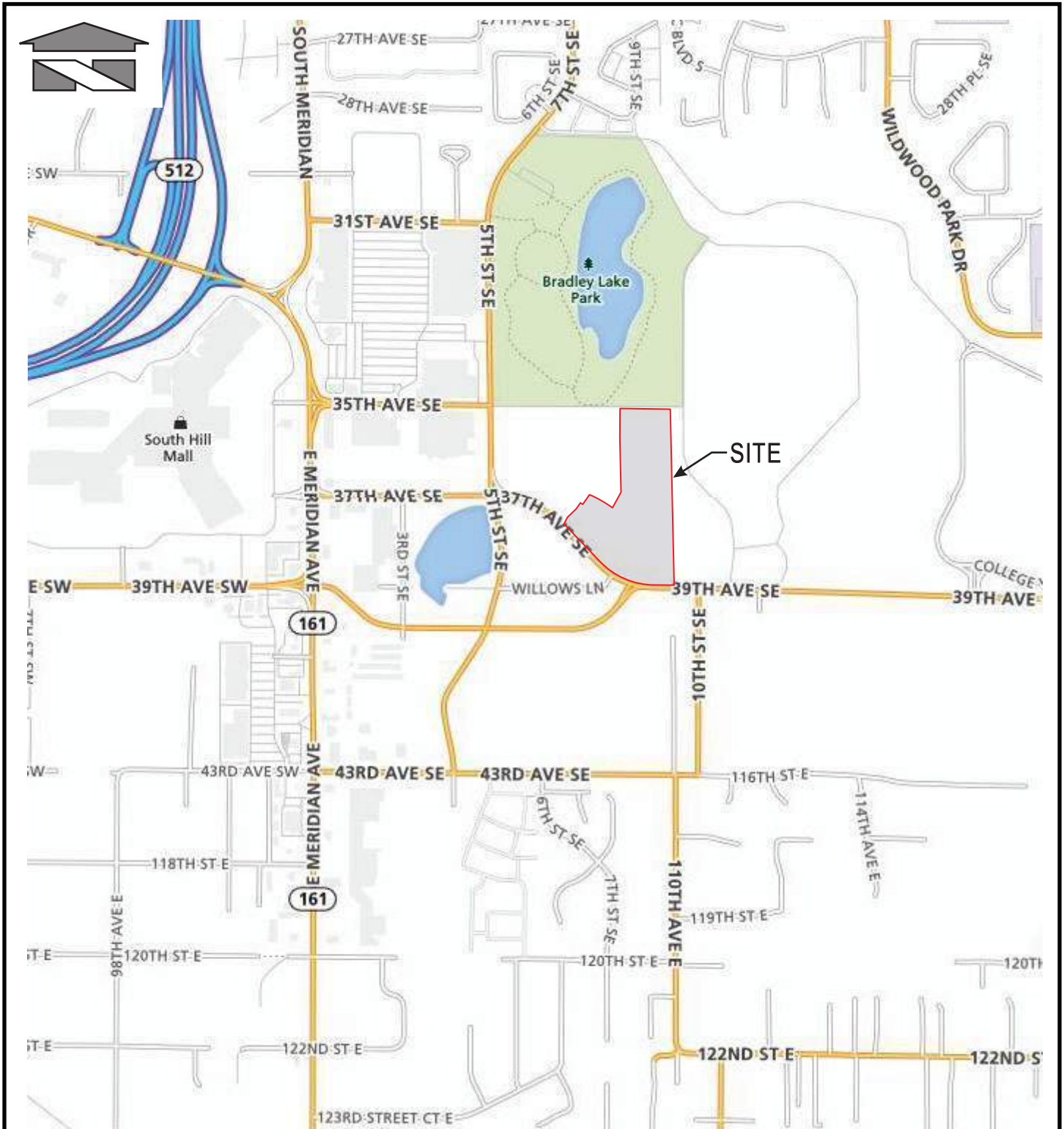

REFERENCE: Rand McNally (2015)

Scale:

Horizontal: N.T.S.

Vertical: N/A

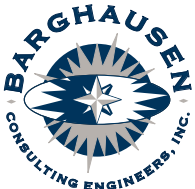

18215 72ND AVENUE SOUTH
 KENT, WA 98032
 (425) 251-6222
 (425) 251-8782

CIVIL ENGINEERING, LAND PLANNING,
 SURVEYING, ENVIRONMENTAL SERVICES

For:

Wesley Homes
 Puyallup, Washington

Title:

VICINITY MAP

Job Number

16718

DATE: 6/30/15

ASSESSOR'S MAP

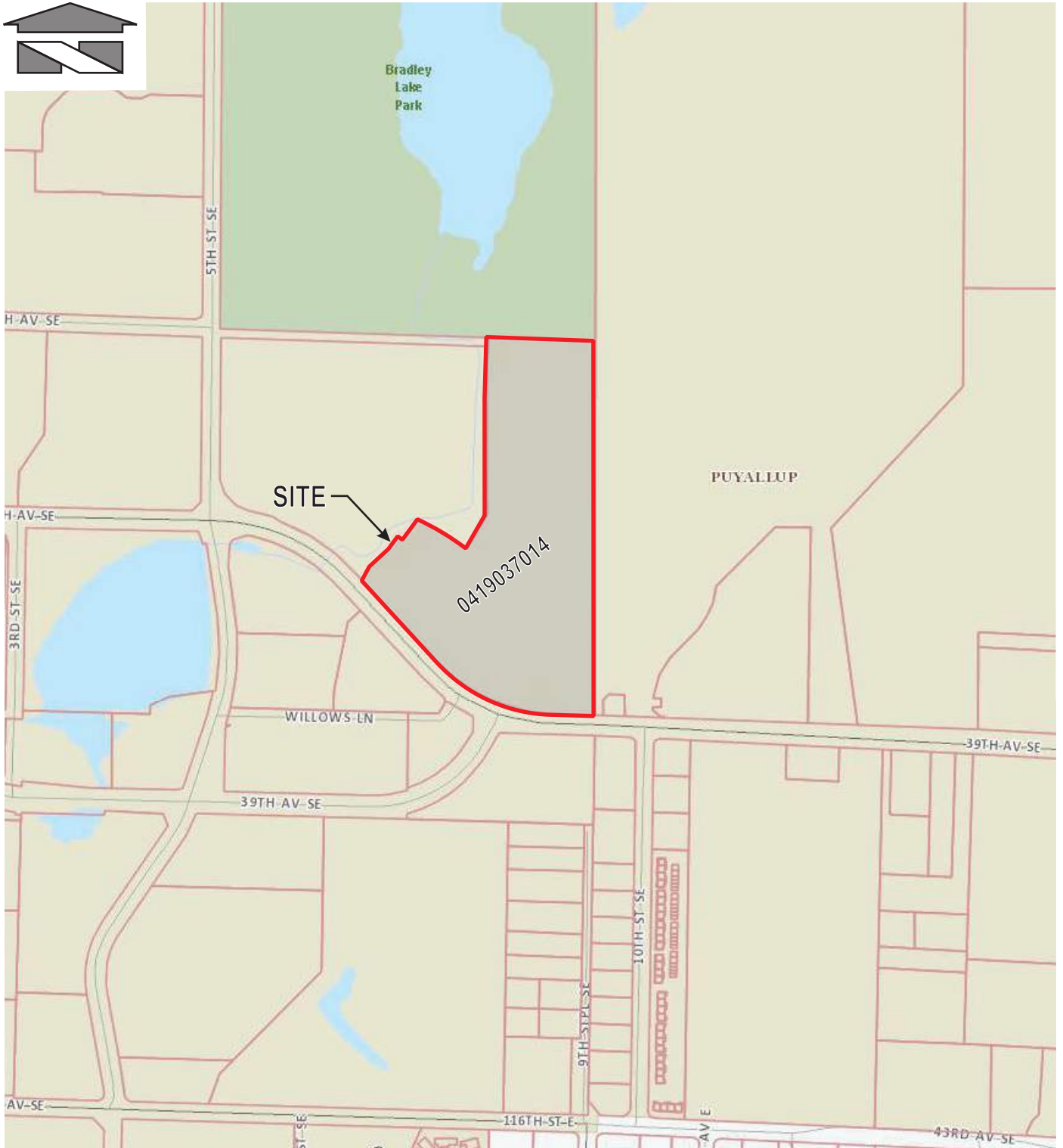

REFERENCE: Pierce County Department of Assessments

Scale:

Horizontal: N.T.S.

Vertical: N/A



18215 72ND AVENUE SOUTH
 KENT, WA 98032
 (425) 251-6222
 (425) 251-8782

CIVIL ENGINEERING, LAND PLANNING,
 SURVEYING, ENVIRONMENTAL SERVICES

For:

Wesley Homes
 Puyallup, Washington

Title:

ASSESSOR MAP

Job Number

16718

DATE: 6/30/15

FEMA MAP

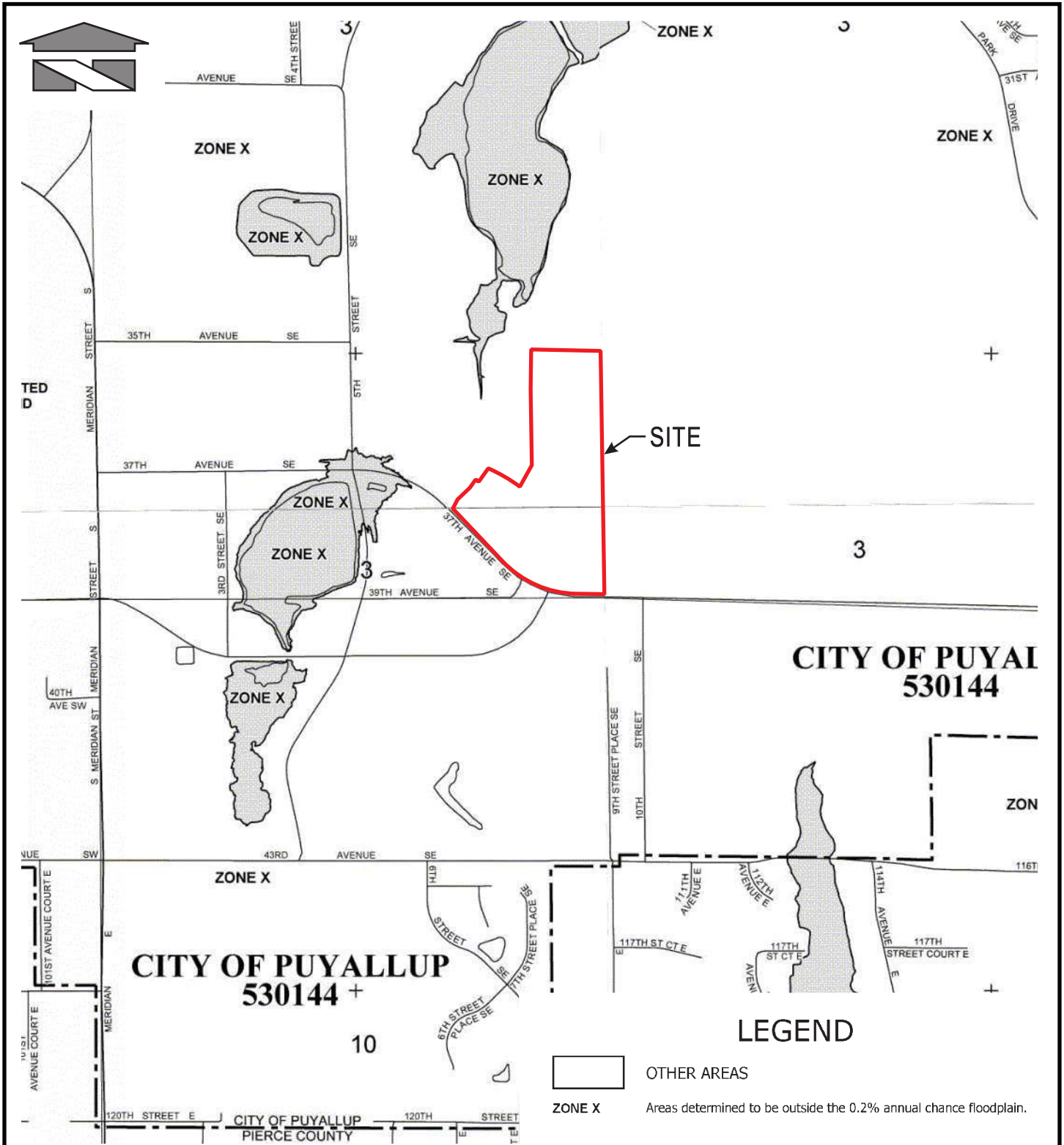

REFERENCE: Federal Emergency Management Agency (Portion of Maps 53053C0341E & 53053C0343E, Mar. 2017)

<p>Scale:</p> <p>Horizontal: N.T.S. Vertical: N/A</p>	<p>For:</p> <p>Wesley Homes Puyallup, Washington</p>	<p>Job Number</p> <p>16718</p>
 <p>18215 72ND AVENUE SOUTH KENT, WA 98032 (425) 251-6222 (425) 251-8782</p> <p>CIVIL ENGINEERING, LAND PLANNING, SURVEYING, ENVIRONMENTAL SERVICES</p>	<p>Title:</p> <p>FEMA MAP</p>	<p>DATE: 3/16/17</p>

SOILS MAP



REFERENCE: USDA, Natural Resources Conservation Service

LEGEND:

- 13B = Everett gravelly sandy loam, 0-6% slopes
- 20B = Kitsap silt loam, 2-8% slopes
- 24D = Neilton gravelly loamy sand, 8-25% slopes

<p>Scale:</p> <p>Horizontal: N.T.S. Vertical: N/A</p>	<p>For:</p> <p style="text-align: center;">Wesley Homes Puyallup, Washington</p>	<p>Job Number</p> <p style="text-align: center;">16718</p>
 <p>18215 72ND AVENUE SOUTH KENT, WA 98032 (425) 251-6222 (425) 251-8782</p> <p>CIVIL ENGINEERING, LAND PLANNING, SURVEYING, ENVIRONMENTAL SERVICES</p>	<p>Title:</p> <p style="text-align: center;">SOIL SURVEY MAP</p>	<p>DATE: 6/30/15</p>

5.0 PERMANENT STORMWATER CONTROL PLAN

5.0 PERMANENT STORMWATER CONTROL PLAN

Part A Existing Site Hydrology

The pre-developed condition used for sizing the flow control facility at this project site was a till forest condition which produces release rates very small in nature therefore, impact to the downstream drainage course are negligible. The area used for modeling this condition is 8.91 acres for the south basin and 1.94 acres for the north basin. The predeveloped condition is shown in the following pages of this document.

Part B Developed Site Hydrology

Under developed conditions there will be two separate drainage basins on the project site, both of which will drain to the same drainage channel after being routed through wetland areas after detention and treatment in the south basin and roof runoff matching hydrology to the north basin wetland. The total area of the south basin is 8.91 acres with 4.99 acres of impervious surface and the north basin consists of 1.94 acres, 1.75 acres of which is rooftop. The WWHM Model was used in sizing the flow control facility which is a combined detention/wetland pond. Calculations can be seen on the following pages of this document as well as the developed basin exhibit.

Part C Performance Standards and Goals

This project meets the Stream Protection Standard of the 2005 Department of Ecology Stormwater Management Manual utilizing WWHM. The conveyance system for this project site was sized using the Santa Barbara Urban Hydrograph (SBUH) methodology which is an accepted conveyance standard as allowed by the 2005 DOE Manual. Enhanced water quality treatment is being provided for through a Stormwater Treatment Wetland BMP T10.30 in the 2005 DOE Manual.

Part D Flow Control System

As mentioned previously, the flow control system, consisting of a combination detention/wetland pond with control structure, on this project site is sized according to the WWHM Model 2012 version and the requirements of the 2005 Department of Ecology manual. To ensure that wetland hydrology for Wetlands A, C and D on site, portions of roof areas from buildings across the site will be directed to each wetland. The pond will be lined with 18 inches compacted till liner per the DOE Manual Volume V, Section 4.4. Please see further calculations and hydroperiod analysis within this section of the report under the Wetland Flow Distribution Exhibit. Calculations sizing the dispersion trenches for the runoff routed to each wetland can also be found in the later part of this section.

Part E Water Quality System

As mentioned previously, a stormwater treatment wetland located below the live storage in the detention pond located in the south basin will treat runoff prior to discharge to the ditch. Enhanced water quality is required because Bradley Lake is a fish bearing lake and the stormwater treatment wetland provides this level of treatment. The constructed wetland is allowed to be located under the live storage if the 2-year mitigated discharge rate is less than 3 feet above the static water surface elevation, which is true for this pond design. Please see the following pages for calculations following BMP T10.30 sizing.

The stormwater runoff from the access road to the Lowe's site towards the west will have separate water quality treatment, as the runoff is released into the pond near the flow control structure and does not go through the presettling cell or travel through the

constructed wetland cell to the full extent necessary to treat the stormwater. A stormfilter catchbasin will be used to treat this runoff. For Stormfilter sizing, the allowable Cartridge flowrate for GULD is 7.5 gpm/cartridge for the 18" cartridge. The 91st percentile of runoff from WWHM Water Quality analysis is used to size the Stormfilter Unit. This is the adjusted 15 min flow output from WWHM, which is 0.0155 cfs or 6.96 gpm. Therefore an 18" stormfilter is adequate at treating the flows for the access road.

There are multiple underground garages for the proposed development. As this development is a senior living facility, the assumed traffic in and out of the garages is relatively small and it is assumed that the event creating the most runoff would be when the garage is washed out by a garden hose or pressure washer. A typical garden hose has a flow of approximately 13 gallons per minute (gpm) and an industrial size pressure washer has a flow of less than 5 gpm. The proposed oil water separators for this site have a maximum process flow of 20 gpm, which is more than adequate to treat the runoff from washing out the parking garage. There are also catchbasins at the entrances to the underground garages to capture any stormwater runoff before entering the garage, which makes any additional stormwater runoff from outside the garage minimal, if any.

A grease interceptor is required for the discharge from the kitchen to the sanitary sewer. Calculations have been provided on the following pages to determine the 1,500 gallon unit is adequate for this site.

Part F Conveyance System Analysis and Design

The conveyance system for the site was sized to convey the 25-year storm event utilizing a precipitation rate of 3.5 inches in a 24-hour period. The SBUH methodology was followed with a time of concentration in each area draining to each catch basin of 5 minutes, which is a conservative rate. A Manning's 'n' value of 0.012 was used for each pipe conveyance element and a backwater analysis was also performed to determine the performance of the conveyance facilities.

GREASE INTERCEPTOR SIZING

A grease interceptor is required for the kitchen in the proposed lodge. This was determined by calculating the number of drainage fixture units (DFUs) for the proposed facility, and using that number in table 1014.3.6 of the Uniform Plumbing Code (UPC) to determine the appropriate grease-interceptor size. The minimum grease interceptor size is a 1,250 gallon unit, but per the city of Puyallup standard detail, there is no grease interceptor of this size and therefore a 1,500 gallon unit will be used. Below is a summary of the fixtures and calculations.

KITCHEN FIXTURE SUMMARY:

FLOOR DRAINS X 4 X (2 DFU)	= 8 DFU
HAND SINKS X 5 X (2 DFU)	= 10 DFU
PREP SINKS X 6 X (3 DFU)	= 18 DFU
MOP SINK X 1 X (3 DFU)	= 3 DFU
3-COMPARTMENT SINK X 1 X (3 DFU)	= 3 DFU
DISHWASHER X 2 X (2 DFU)	= 4 DFU
<u>INDIRECT WASTE X 7 X (1 DFU)</u>	<u>= 7 DFU</u>
TOTAL	= 53 DFU

CAPACITY:

Total number of DFUs based on the kitchen fixture connection schedule from plumbing plan sheet P0.01 and summarized above = **53 DFU**

Per table 1014.3.6 UPC minimum grease interceptor sizing = 1250 gallons

As there is no 1250 gallon grease interceptor per City of Puyallup standard detail, **use 1500 gallon** grease interceptor to be used per City of Puyallup detail.

FLOW CONTROL AND WATER QUALITY SIZING CRITERIA

North Basin:

Roof area to wetland = 0.75 Acres

South Basin:

Impervious = 6.18 Acres

Pervious = 3.92 Acres

Total Area = 10.10 Acres

Detention Volume Required = 128,000 cf

Detention Volume Provided = 128,000 cf

Water Quality volume = 0.7209 ac-ft

Water Quality Volume Summary

Project: Wesley Homes Puyallup

BCE #: 16718

REQUIRED WQ VOLUME (PER WWHM) = 31,402 CF (0.7209 ac-ft)

Water Quality Volume Provided = 33,500 CF*

*Per DOE Sizing procedure of BMP T10.30, step 5 notes that, " This [sizing] will result in a facility that holds less volume than that determined in Step 1 above. This is acceptable."

Presetting Cell (1) Pond Volume Summary

Elevation (ft)	Area (sf)	Inc. Volume (cf)	Total Volume (cf)
447.00	2,451	0	0
448.00	3,481	2,966	2,966
449.00	4,590	4,036	7,002
450.00	5,765	5,178	12,179
451.00	7,013	6,389	18,568

Wetland Cell (2) Pond Volume Summary

Elevation (ft)	Area (sf)	Inc. Volume (cf)	Total Volume (cf)
449.00	2,339	0	0
450.00	7,894	5,117	5,117
451.00	11,526	9,710	14,827

CELL 1

WQ WSE	451
Length (@ WQ WSE)	150
Width (@ WQ WSE)	46
Length/Width Ratio	3.2:1

CELL 2

WQ WSE	451
Length (@ WQ WSE)	192
Width (@ WQ WSE)	46
Length/Width Ratio	4.17:1

Detention Pond Volume Summary

Project:	Wesley Homes Puyallup
BCE #:	16718
REQUIRED DETENTION VOLUME =128,000 CF	
Detention Volume Provided = 128,000 CF	

Detention Pond Volume Summary			
Elevation (ft)	Area (sf)	Inc. Volume (cf)	Total Volume (cf)
451.00	18,821	0	0
452.00	21,459	20,140	20,140
453.00	24,157	22,808	42,948
454.00	26,931	25,544	68,492
455.00	29,766	28,349	96,841
456.00	32,668	31,217	128,058

Max WSE =	456
Length (@ WSE) =	380
Width (@ WSE) =	77
Length/Width Ratio =	4.9:1

CONSTRUCTED WETLAND CALCULATIONS

1. Volume of water quality required = 0.7209 ac-ft (from WWHM calculations)
2. Surface Area of stormwater wetland required = $(0.7209 \times 43,560)/3 = 10,468$ sf
 - a. S.A. available at bottom of live storage = 18,402 sf
3. Presettling cell surface area required = $10,468 / 4 = 2,617$ sf
 - a. Presettling surface area provided = 7,013 sf
 - b. Presettling volume provided = 18,568 cf
4. Wetland cell surface area required = $10,468 - 2,617 = 7,851$ sf
 - a. Wetland cell surface area provided = 11,526 sf
5. Depth distribution of second cell
 - a. Berm at WQ Design Water Surface
 - i. 0.1' to 1' = 25%
 - ii. 1' to 2' = 55%
 - iii. 2'-2.5" = 20%

FLOW SPLITTING CALCULATIONS

The pond flow will be split with a portion of the runoff going to Wetland A, and a portion going to the Lowe's drainage ditch.

The orifice that will convey stormwater to Wetland A has already been determined to be 1.25" for the for the bottom orifice. Knowing these diameters, heights, head, and the flowrate that needs to be maintained at these elevations to provide adequate flow control for the site, the orifice sizing to the drainage ditch is calculated below.

Pond Full to Top of Riser Release Rates

		<u>HEAD</u> (H, ft)
Bottom Orifice	= 0.1364 cfs	5.0'
Middle Orifice	= 0.1615 cfs	1.435'
Top Orifice	= 0.0494 cfs	1.0'

DETERMINATION OF PROPORTIONAL FLOW

<u>To Wetland A</u>	<u>Q_A</u>	<u>To Drainage Ditch</u>	<u>Q_X</u>
Bottom O.D @ 1.25" =	0.0947	Bottom = 0.1364 - 0.0947 =	0.0417
Middle O.D. @ 0" =	0	Middle = 0.1615 - 0 =	0.1615
Top O.D. @ 0" =	0	Top = 0.0189 - 0 =	0.0494

Using equation for orifice diameter (inches), and solving:

$$\text{Orifice Diameter (O.D.)} = \sqrt{\frac{36.88Q}{\sqrt{H}}} = \left((36.88Q)/(H)^{1/2} \right)^{1/2}$$

<u>North</u>	<u>East</u>
Btm O.D. = 1-1/4"	Btm O.D. = 7/8"
Mid O.D. = 0"	Mid. O.D. = 2-1/4"
Top O.D. = 0"	Top O.D. = 1-1/4"

OIL/WATER SEPARATOR DETAILS

25-CPS OIL WATER SEPARATOR

Projected Plate Area = 64 Sq/ft
 Maximum Process Flow = 60 GPM

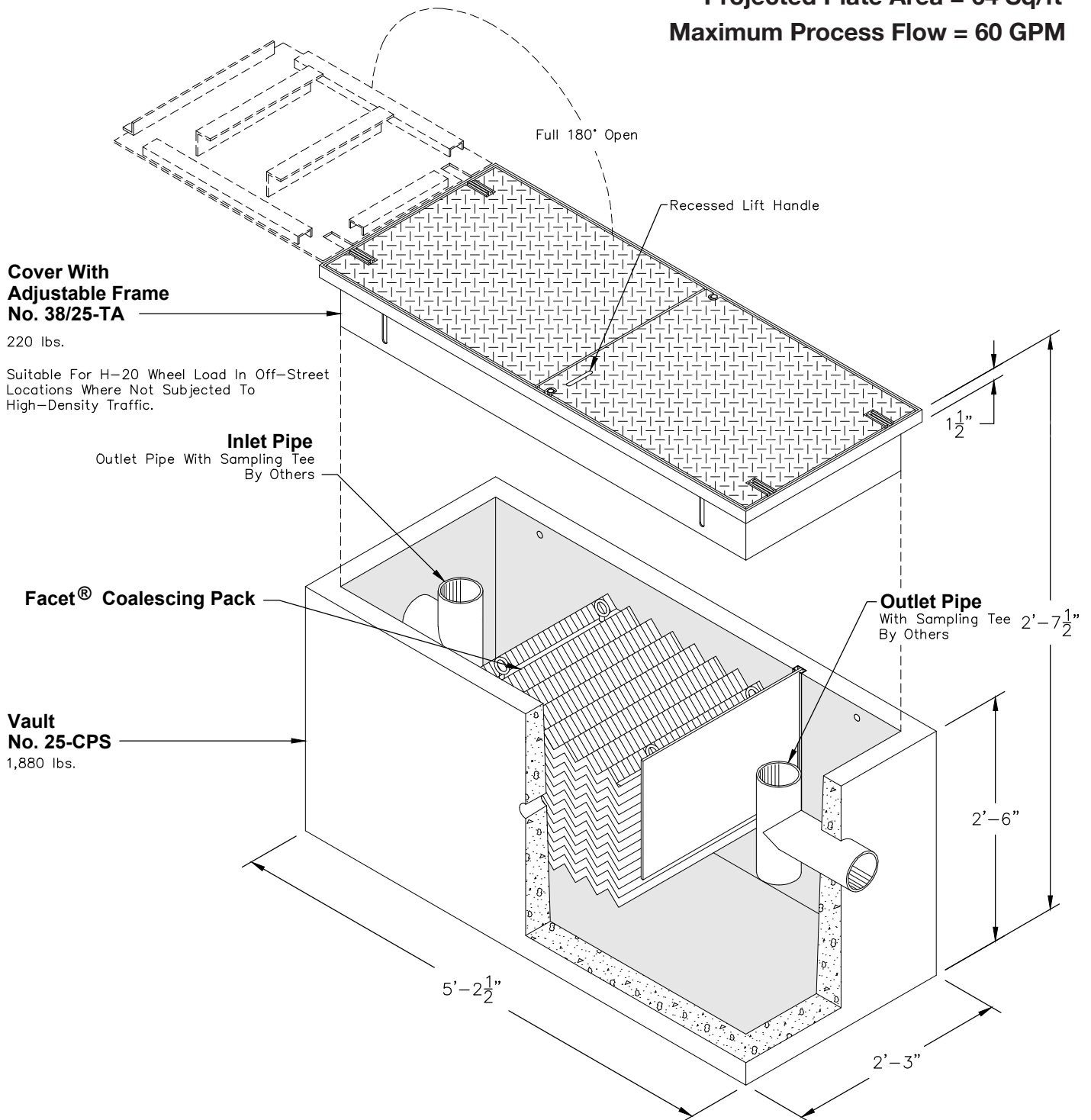

FOR DETAILS, SEE REVERSE >>

Items Shown Are Subject To Change Without Notice
 Issue Date: August 2012

25-CPS

Projected Plate Area = 64 Sq/ft

Maximum Process Flow = 60 GPM

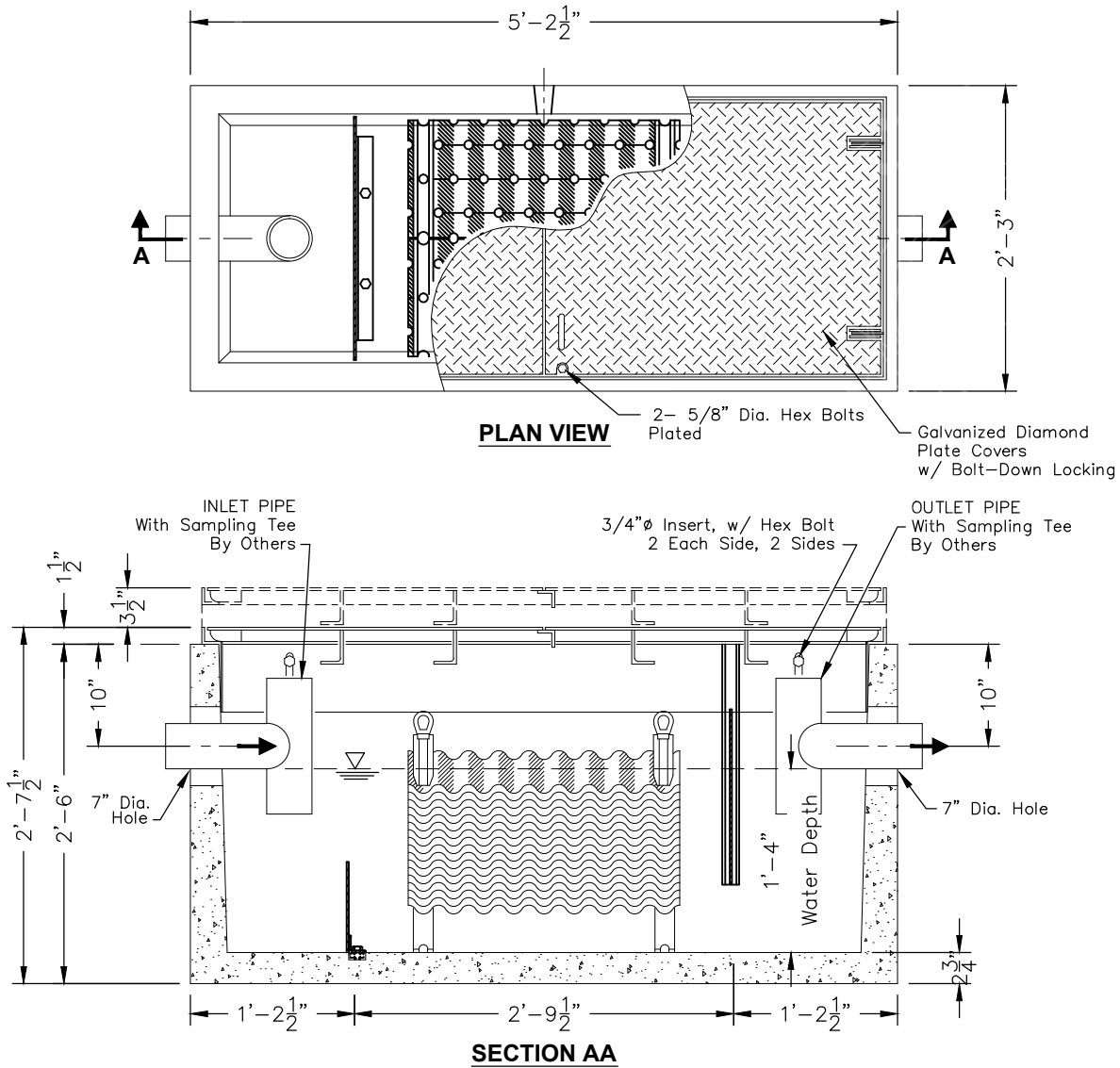

- STRUCTURAL NOTES:**
1. Concrete: 28 Day Compressive Strength $f'_c = 7000$ psi
 2. Rebar: ASTM A-615 Grade 60
 3. Mesh: ASTM A-185 Grade 65
 4. Design: ACI-318-05 Building Code
ASTM C-890 "Minimum Structural Design Loading For Underground Precast Concrete Water and Wastewater Structures"
 5. Loads: HS-20 Truck Wheel w/ 30% Impact Per AASHTO

- GENERAL NOTES:**
1. All Baffles and Weirs To Be 3/16" Steel Plate
 2. Static Water Depth = 1'-4"
 3. Contractor to:
Supply and Install All Piping & Sampling Tees
Grout In All Pipes
Fill With Clean Water Prior To "Start-Up" Of System
Verify All Blockout Sizes and Locations

- INFORMATION NEEDED:**
- Top Of Separator Elevation:
 - Inlet Pipe Size:
 - Inlet Pipe Elevation:
 - Outlet Pipe Size:
 - Outlet Pipe Elevation:

- BASIC DESIGN INFORMATION:**
- INFLUENT CHARACTERISTICS:**
- Oil Specific Gravity: 0.88
 - Operating Temperature: 50°
 - Influent Oil Concentration: 100 ppm
 - Mean Oil Droplet Size: 130 Microns
 - 0.033 ft/min Oil Rise Rate
 - Designed Per Washington State Department Of Ecology

FLOW RATE	EFFLUENT QUALITY	100% COLLECTED SIZE
20 GPM	10 ppm	60 Micron

SCALE: 3/4" = 1'-0"

STORMFILTER DETAIL

STORMFILTER STEEL CATCHBASIN DESIGN NOTES

STORMFILTER TREATMENT CAPACITY IS A FUNCTION OF THE CARTRIDGE SELECTION AND THE NUMBER OF CARTRIDGES. 1 CARTRIDGE CATCHBASIN HAS A MAXIMUM OF ONE CARTRIDGE. SYSTEM IS SHOWN WITH A 27" CARTRIDGE, AND IS ALSO AVAILABLE WITH AN 18" CARTRIDGE. STORMFILTER CATCHBASIN CONFIGURATIONS ARE AVAILABLE WITH A DRY INLET BAY FOR VECTOR CONTROL. PEAK HYDRAULIC CAPACITY PER TABLE BELOW. IF THE SITE CONDITIONS EXCEED PEAK HYDRAULIC CAPACITY, AN UPSTREAM BYPASS STRUCTURE IS REQUIRED.

CARTRIDGE SELECTION

CARTRIDGE HEIGHT	27"			18"			18" DEEP		
RECOMMENDED HYDRAULIC DROP (H)	3.05'			2.3'			3.3'		
SPECIFIC FLOW RATE (gpm/sf)	2 gpm/sf	1.67* gpm/sf	1 gpm/sf	2 gpm/sf	1.67* gpm/sf	1 gpm/sf	2 gpm/sf	1.67* gpm/sf	1 gpm/sf
CARTRIDGE FLOW RATE (gpm)	22.5	18.79	11.25	15	12.53	7.5	15	12.53	7.5
PEAK HYDRAULIC CAPACITY	1.0			1.0			1.8		
INLET PERMANENT POOL LEVEL (A)	1'-0"			1'-0"			2'-0"		
OVERALL STRUCTURE HEIGHT (B)	4'-9"			3'-9"			4'-9"		

* 1.67 gpm/sf SPECIFIC FLOW RATE IS APPROVED WITH PHOSPHOSORB® (PSORB) MEDIA ONLY

GENERAL NOTES

- CONTECH TO PROVIDE ALL MATERIALS UNLESS NOTED OTHERWISE.
- FOR SITE SPECIFIC DRAWINGS WITH DETAILED STORMFILTER CATCHBASIN STRUCTURE DIMENSIONS AND WEIGHTS, PLEASE CONTACT YOUR CONTECH ENGINEERED SOLUTIONS LLC REPRESENTATIVE. www.contechES.com
- STORMFILTER CATCHBASIN WATER QUALITY STRUCTURE SHALL BE IN ACCORDANCE WITH ALL DESIGN DATA AND INFORMATION CONTAINED IN THIS DRAWING.
- INLET SHOULD NOT BE LOWER THAN OUTLET. INLET (IF APPLICABLE) AND OUTLET PIPING TO BE SPECIFIED BY ENGINEER AND PROVIDED BY CONTRACTOR.
- MANUFACTURER TO APPLY A SURFACE BEAD WELD IN THE SHAPE OF THE LETTER "O" ABOVE THE OUTLET PIPE STUB ON THE EXTERIOR SURFACE OF THE STEEL SFCB.
- STORMFILTER CATCHBASIN EQUIPPED WITH 4 INCH (APPROXIMATE) LONG STUBS FOR INLET (IF APPLICABLE) AND OUTLET PIPING. STANDARD OUTLET STUB IS 8 INCHES IN DIAMETER. MAXIMUM OUTLET STUB IS 15 INCHES IN DIAMETER. CONNECTION TO COLLECTION PIPING CAN BE MADE USING FLEXIBLE COUPLING BY CONTRACTOR.
- STEEL STRUCTURE TO BE MANUFACTURED OF 1/4 INCH STEEL PLATE. CASTINGS SHALL MEET AASHTO M306 LOAD RATING. TO MEET HS20 LOAD RATING ON STRUCTURE, A CONCRETE COLLAR IS REQUIRED. WHEN REQUIRED, CONCRETE COLLAR WITH #4 REINFORCING BARS TO BE PROVIDED BY CONTRACTOR.
- FILTER CARTRIDGES SHALL BE MEDIA-FILLED, PASSIVE, SIPHON ACTUATED, RADIAL FLOW, AND SELF CLEANING. RADIAL MEDIA DEPTH SHALL BE 7-INCHES. FILTER MEDIA CONTACT TIME SHALL BE AT LEAST 38 SECONDS.
- SPECIFIC FLOW RATE IS EQUAL TO THE FILTER TREATMENT CAPACITY (gpm) DIVIDED BY THE FILTER CONTACT SURFACE AREA (sq ft).

INSTALLATION NOTES

- ANY SUB-BASE, BACKFILL DEPTH, AND/OR ANTI-FLOTATION PROVISIONS ARE SITE-SPECIFIC DESIGN CONSIDERATIONS AND SHALL BE SPECIFIED BY ENGINEER OF RECORD.
- CONTRACTOR TO PROVIDE EQUIPMENT WITH SUFFICIENT LIFTING AND REACH CAPACITY TO LIFT AND SET THE CATCHBASIN (LIFTING CLUTCHES PROVIDED).
- CONTRACTOR TO TAKE APPROPRIATE MEASURES TO PROTECT CARTRIDGES FROM CONSTRUCTION-RELATED EROSION RUNOFF.

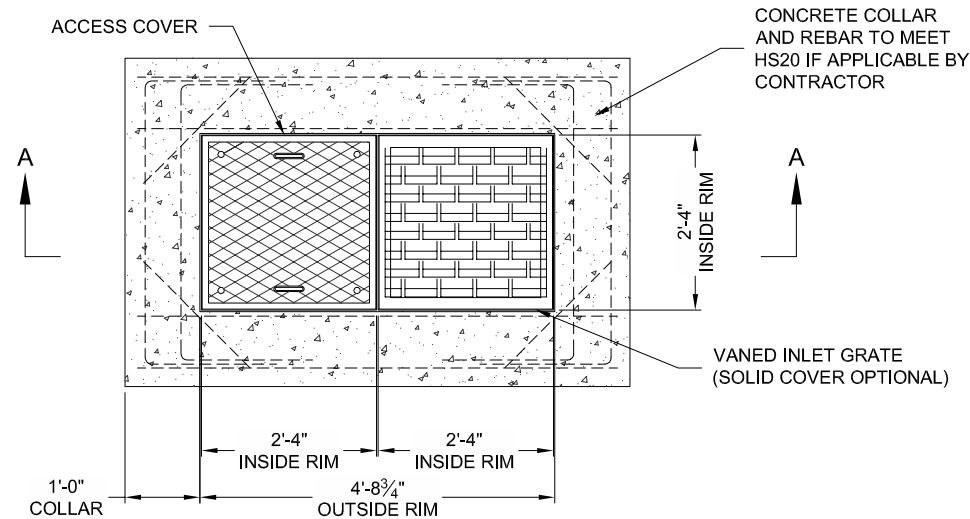

PLAN VIEW

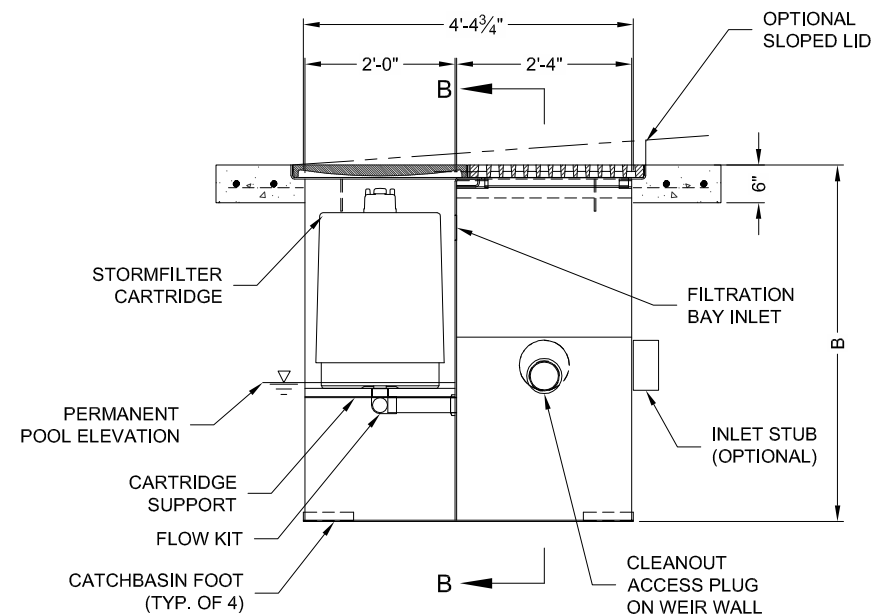

SECTION A-A

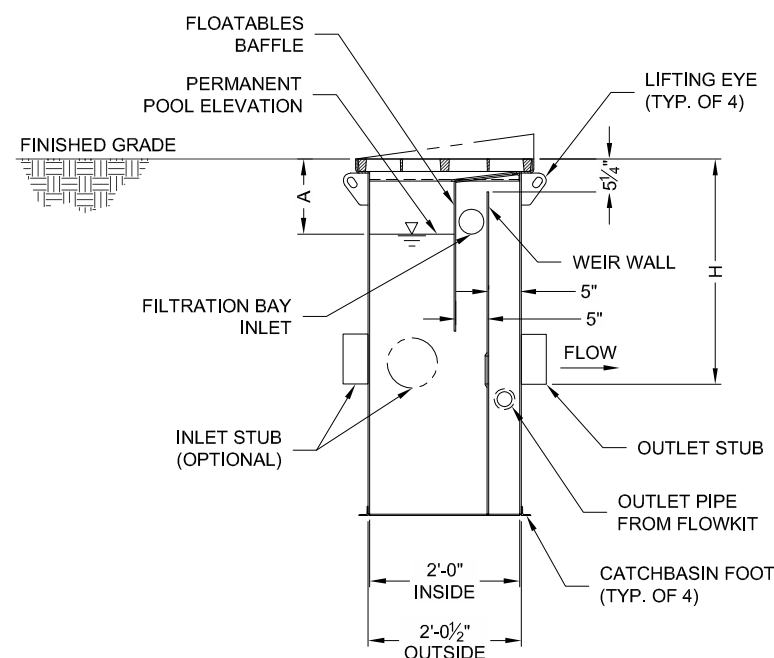

SECTION B-B

1-CARTRIDGE CATCHBASIN STORMFILTER DATA

STRUCTURE ID	CB #22
WATER QUALITY FLOW RATE (cfs)	0.0155
PEAK FLOW RATE (<1 cfs)	0.0918
RETURN PERIOD OF PEAK FLOW (yrs)	100
CARTRIDGE HEIGHT (27", 18", 18" DEEP)	18"
CARTRIDGE FLOW RATE (gpm)	7.5
MEDIA TYPE (PERLITE, ZPG, PSORB)	PERLITE
RIM ELEVATION	457.73

PIPE DATA:	I.E.	DIAMETER
INLET STUB	453.00	12"
OUTLET STUB	453.00	12"

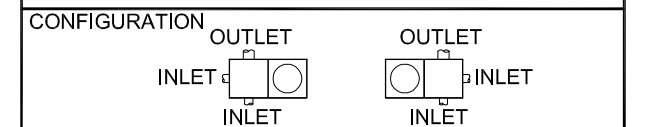

SLOPED LID	YES/NO
SOLID COVER	YES/NO
NOTES/SPECIAL REQUIREMENTS:	

DISPERSAL TRENCH SIZING

To size the dispersal trenches for this project, a maximum height of water flowing over the grade board is 0.05 feet, the roughness coefficient used is 0.35. The maximum slope on either side of the dispersion trench is 20% and varies based on the slope of the downside of the trench.

Worksheet for Wetland A

Project Description

Friction Method Manning Formula
Solve For Bottom Width

Input Data

Roughness Coefficient	0.350	
Channel Slope	0.20000	ft/ft
Normal Depth	0.05	ft
Discharge	0.33	ft ³ /s

Results

Bottom Width	25.68	ft
Flow Area	1.28	ft ²
Wetted Perimeter	25.78	ft
Hydraulic Radius	0.05	ft
Top Width	25.68	ft
Critical Depth	0.02	ft
Critical Slope	6.90387	ft/ft
Velocity	0.26	ft/s
Velocity Head	0.00	ft
Specific Energy	0.05	ft
Froude Number	0.20	
Flow Type	Subcritical	

GVF Input Data

Downstream Depth	0.00	ft
Length	0.00	ft
Number Of Steps	0	

GVF Output Data

Upstream Depth	0.00	ft
Profile Description		
Profile Headloss	0.00	ft
Downstream Velocity	Infinity	ft/s
Upstream Velocity	Infinity	ft/s
Normal Depth	0.05	ft
Critical Depth	0.02	ft
Channel Slope	0.20000	ft/ft
Critical Slope	6.90387	ft/ft

Worksheet for Wetland C

Project Description

Friction Method Manning Formula
Solve For Bottom Width

Input Data

Roughness Coefficient	0.350	
Channel Slope	0.10000	ft/ft
Normal Depth	0.05	ft
Discharge	0.21	ft ³ /s

Results

Bottom Width	23.34	ft
Flow Area	1.17	ft ²
Wetted Perimeter	23.44	ft
Hydraulic Radius	0.05	ft
Top Width	23.34	ft
Critical Depth	0.01	ft
Critical Slope	7.46275	ft/ft
Velocity	0.18	ft/s
Velocity Head	0.00	ft
Specific Energy	0.05	ft
Froude Number	0.14	
Flow Type	Subcritical	

GVF Input Data

Downstream Depth	0.00	ft
Length	0.00	ft
Number Of Steps	0	

GVF Output Data

Upstream Depth	0.00	ft
Profile Description		
Profile Headloss	0.00	ft
Downstream Velocity	Infinity	ft/s
Upstream Velocity	Infinity	ft/s
Normal Depth	0.05	ft
Critical Depth	0.01	ft
Channel Slope	0.10000	ft/ft
Critical Slope	7.46275	ft/ft

Worksheet for Wetland D

Project Description

Friction Method Manning Formula
Solve For Bottom Width

Input Data

Roughness Coefficient	0.350	
Channel Slope	0.10000	ft/ft
Normal Depth	0.05	ft
Discharge	0.29	ft ³ /s

Results

Bottom Width	31.80	ft
Flow Area	1.59	ft ²
Wetted Perimeter	31.90	ft
Hydraulic Radius	0.05	ft
Top Width	31.80	ft
Critical Depth	0.01	ft
Critical Slope	7.45963	ft/ft
Velocity	0.18	ft/s
Velocity Head	0.00	ft
Specific Energy	0.05	ft
Froude Number	0.14	
Flow Type	Subcritical	

GVF Input Data

Downstream Depth	0.00	ft
Length	0.00	ft
Number Of Steps	0	

GVF Output Data

Upstream Depth	0.00	ft
Profile Description		
Profile Headloss	0.00	ft
Downstream Velocity	Infinity	ft/s
Upstream Velocity	Infinity	ft/s
Normal Depth	0.05	ft
Critical Depth	0.01	ft
Channel Slope	0.10000	ft/ft
Critical Slope	7.45963	ft/ft

WETLAND FLOW DISTRIBUTION EXHIBIT

WETLAND FLOW DISTRIBUTION EXHIBIT

An analysis was done comparing the runoff volumes from the predeveloped area draining to the wetlands and the developed areas to be routed to each wetland. The predeveloped condition for the site is mostly forested, with some soils modeled as pasture area.

For the mitigated condition for the wetlands, the point of compliance has been modeled as an area of saturated pervious land that represents the land flow will travel across before entering into the appropriate wetland. To determine the roof areas that should flow to each wetland, the model was run through many iterations to match the predeveloped and developed runoff volumes over an annual interval. The roof runoff to Wetlands C and D is directed through dispersion trenches with no detention. Wetland A has the runoff routed from the detention pond through a flow control structure to reach these volumes after detention. The predeveloped average annual runoff to wetland C is 0.895 acre-feet. The developed condition was matched within 1% by routing 0.30 acres of roof which corresponds to 0.900 acre-feet of runoff volume. For wetland D, the predeveloped annual runoff is 1.274 acre-feet and the proposed condition of 0.45 acres of roof draining to the wetland is 1.294 acre-feet which is within 2 percent of the predeveloped condition. For wetland A, the predeveloped annual runoff is 9.87 acre-feet of runoff volume with 10.80 acre-feet for the developed condition, which is within 9 percent of the predeveloped condition.

This is a slope wetland, and per the DOE 2012 Manual in Appendix I-D, this model and outputs of WWHM in regards to wetlands are more accurate for depressional wetlands and less so for a slope wetlands. Therefore, the criteria for determining wetland runoff volumes within WWHM 2012 has been used as guidance to determine runoff areas appropriate for this situation. That being said, the addition of more water to this wetland over the course of the year will not cause ponding within the wetland and continue into the Lowe's drainage ditch downstream from the site. Erosion is more of a concern with the additional flow in this situation. The use of dispersion trenches to convey the stormwater runoff into the wetland will minimize the erosion potential and excess runoff is preferable to a lack of runoff.

Wetland	Predeveloped Basin Area	Developed Basin Area
A	6.96 AC	10.85 ac* *(release from pond)
C	0.63 AC	0.30 AC
D	0.90 AC	0.45 AC

Wetland	Predeveloped Volume (ac-ft)	Developed Volume (ac-ft)	Percent Difference
A	9.8868	10.8027	9%
C	0.8947	0.8999	1%
D	1.2744	1.2941	2%

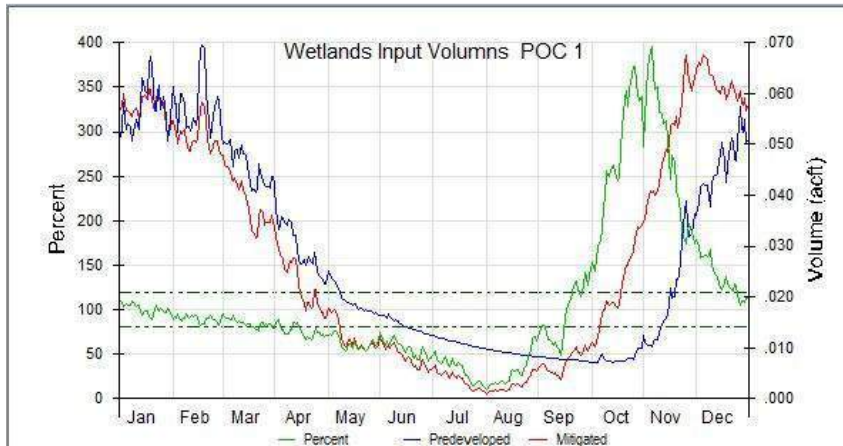

Wetlands Fluctuation for POC 1			
Average Annual Volume (acft)			
Month	Predevel	Mitigated	Percent E
Jan	1.7631	1.8769	106.5
Feb	1.6428	1.5895	96.8
Mar	1.4216	1.3346	93.9
Apr	0.9026	0.7552	83.7
May	0.6023	0.4092	67.9
Jun	0.4343	0.2734	63.0
Jul	0.3433	0.1164	33.9
Aug	0.2779	0.0767	27.6
Sep	0.2324	0.2210	95.1
Oct	0.2434	0.6542	268.8
Nov	0.6087	1.5036	247.0
Dec	1.4144	1.9931	140.9

Wetland A

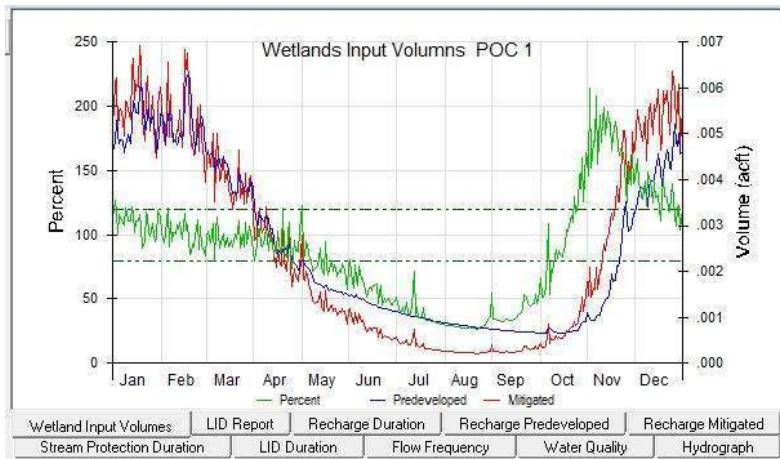

Wetlands Fluctuation for POC 1			
Average Annual Volume (acft)			
Month	Predevel	Mitigated	Percent E
Jan	0.1596	0.1749	109.6
Feb	0.1487	0.1501	100.9
Mar	0.1287	0.1253	97.4
Apr	0.0817	0.0762	93.2
May	0.0545	0.0438	80.3
Jun	0.0393	0.0234	59.5
Jul	0.0311	0.0122	39.1
Aug	0.0252	0.0073	28.9
Sep	0.0210	0.0083	39.6
Oct	0.0220	0.0216	98.0
Nov	0.0550	0.0909	165.3
Dec	0.1279	0.1659	129.7

Day	Predevel	Mitigated	Percent E
Jan1	0.0046	0.0051	112.2
2	0.0048	0.0061	126.8
3	0.0053	0.0062	118.0
4	0.0050	0.0050	100.4
5	0.0048	0.0055	115.3

Wetland C

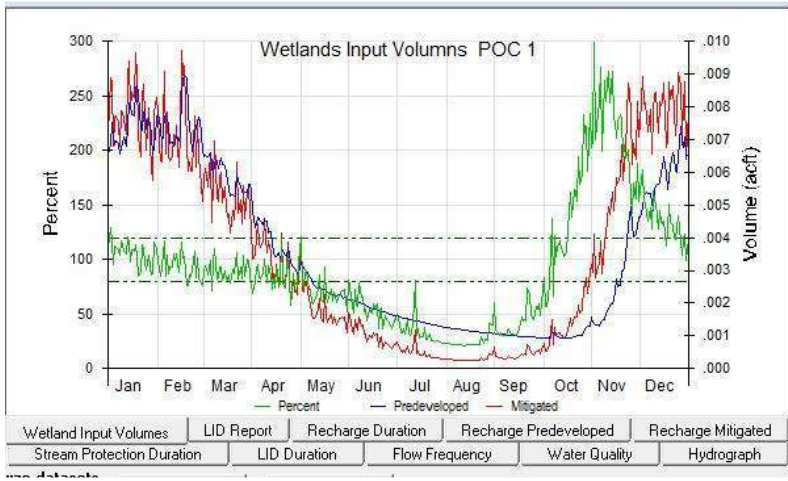

Wetlands Fluctuation for POC 1			
Average Annual Volume (acft)			
Month	Predevel	Mitigated	Percent E
Jan	0.2273	0.2408	105.9
Feb	0.2121	0.2019	95.2
Mar	0.1838	0.1646	89.6
Apr	0.1168	0.0981	84.0
May	0.0779	0.0574	73.6
Jun	0.0562	0.0312	55.5
Jul	0.0444	0.0149	33.7
Aug	0.0359	0.0088	24.4
Sep	0.0300	0.0126	41.9
Oct	0.0313	0.0431	137.7
Nov	0.0773	0.1595	206.2
Dec	0.1814	0.2441	134.5

Day	Predevel	Mitigated	Percent E
Jan1	0.0065	0.0072	109.9
2	0.0069	0.0089	129.8
3	0.0075	0.0088	116.8
4	0.0071	0.0068	95.7
5	0.0068	0.0076	112.0

Wetland D

WETLAND A - FLOW FROM DETENTION POND

MONTH	PREDEVELOPED VOLUME (AC-FT)	DEVELOPED VOLUME (AC-FT)	DIFFERENCE (ABSOLUTE VALUE AC-FT)	PERCENT DIFFERENCE
Jan	1.7631	1.8769	0.1138	6%
Feb	1.6428	1.5895	0.0533	3%
Mar	1.4216	1.3346	0.087	6%
Apr	0.9026	0.7552	0.1474	16%
May	0.6023	0.4081	0.1942	32%
Jun	0.4343	0.2734	0.1609	37%
Jul	0.3433	0.1164	0.2269	66%
Aug	0.2779	0.0767	0.2012	72%
Sep	0.2324	0.2210	0.0114	5%
Oct	0.2434	0.6542	0.4108	169%
Nov	0.6087	1.5036	0.8949	147%
Dec	1.4144	1.9931	0.5787	41%
TOTALS	9.8868	10.8027	0.9159	9%

	Diameter to Wetland (in.)	Diameter to drainage ditch (in.)	Orifice elevation (ft)
ORIFICE 1	1.25	0.88	451.00
ORIFICE 2	0	2.25	454.57
ORIFICE 3	0	1.25	455.00

WETLAND C - FLOW FROM ROOF

MONTH	PREDEVELOPED VOLUME (AC-FT)	DEVELOPED VOLUME (AC-FT)	DIFFERENCE (ABSOLUTE VALUE AC-FT)	PERCENT DIFFERENCE
Jan	0.1596	0.1749	0.0153	10%
Feb	0.1487	0.1501	0.0014	1%
Mar	0.1287	0.1253	0.0034	3%
Apr	0.0817	0.0762	0.0055	7%
May	0.0545	0.0438	0.0107	20%
Jun	0.0393	0.0234	0.0159	40%
Jul	0.0311	0.0122	0.0189	61%
Aug	0.0252	0.0073	0.0179	71%
Sep	0.021	0.0083	0.0127	60%
Oct	0.022	0.0216	0.0004	2%
Nov	0.055	0.0909	0.0359	65%
Dec	0.1279	0.1659	0.038	30%
TOTALS	0.8947	0.8999	0.0052	1%

WETLAND D - FLOW FROM ROOF

MONTH	PREDEVELOPED VOLUME (AC-FT)	DEVELOPED VOLUME (AC-FT)	DIFFERENCE (ABSOLUTE VALUE AC-FT)	PERCENT DIFFERENCE
Jan	0.2273	0.2408	0.0135	6%
Feb	0.2121	0.219	0.0069	3%
Mar	0.1838	0.1646	0.0192	10%
Apr	0.1168	0.0981	0.0187	16%
May	0.0779	0.0574	0.0205	26%
Jun	0.0562	0.0312	0.025	44%
Jul	0.0444	0.0149	0.0295	66%
Aug	0.0359	0.0088	0.0271	75%
Sep	0.03	0.0126	0.0174	58%
Oct	0.0313	0.0431	0.0118	38%
Nov	0.0773	0.1595	0.0822	106%
Dec	0.1814	0.2441	0.0627	35%
TOTALS	1.2744	1.2941	0.0197	2%

PREDEVELOPED WETLAND BASIN MAP

PREDEVELOPED BASIN MAP FOR WESLEY HOMES PUYALLUP

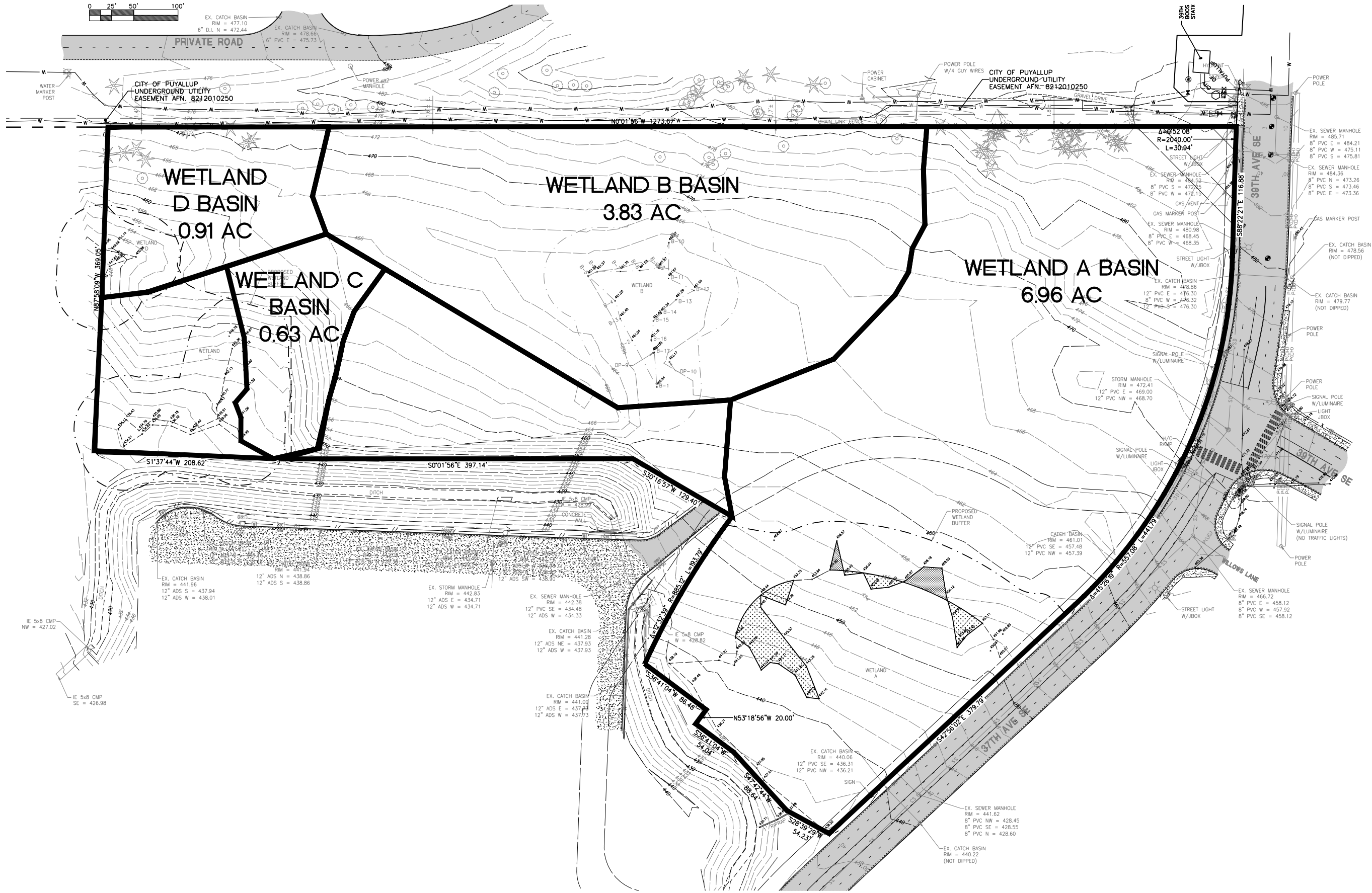
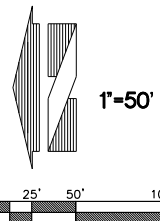

No.	Date	By	Chd.	Appr.	Revision

Title:
PREDEVELOPED BASIN MAP
WESLEY HOMES
PUYALLUP, WA

For:
WESLEY HOMES
PUYALLUP, WA

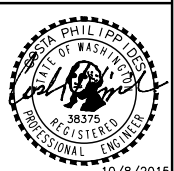

Scale:	Horizontal	1"=60'
	Vertical	N/A
Designed	CP	
Drawn	CK	
Checked	CP	
Approved	CP	
Date	6/25/14	

18215 72ND AVENUE SOUTH
KENT, WA 98032
(425)251-6222
(425)251-8782 FAX
CIVIL ENGINEERING, LAND PLANNING,
SURVEYING, ENVIRONMENTAL SERVICES



Job Number
16718
Sheet
1 of 1

File:PA\16000a\16718-basin.mxd Date/Time:3/27/2017 3:31 PM Scale:1" = 1' WDU:JAP Xref: ---

ROOF AREA DISTRIBUTION

WETLAND DEVELOPED AREAS MAP FOR WESLEY HOMES PUYALLUP

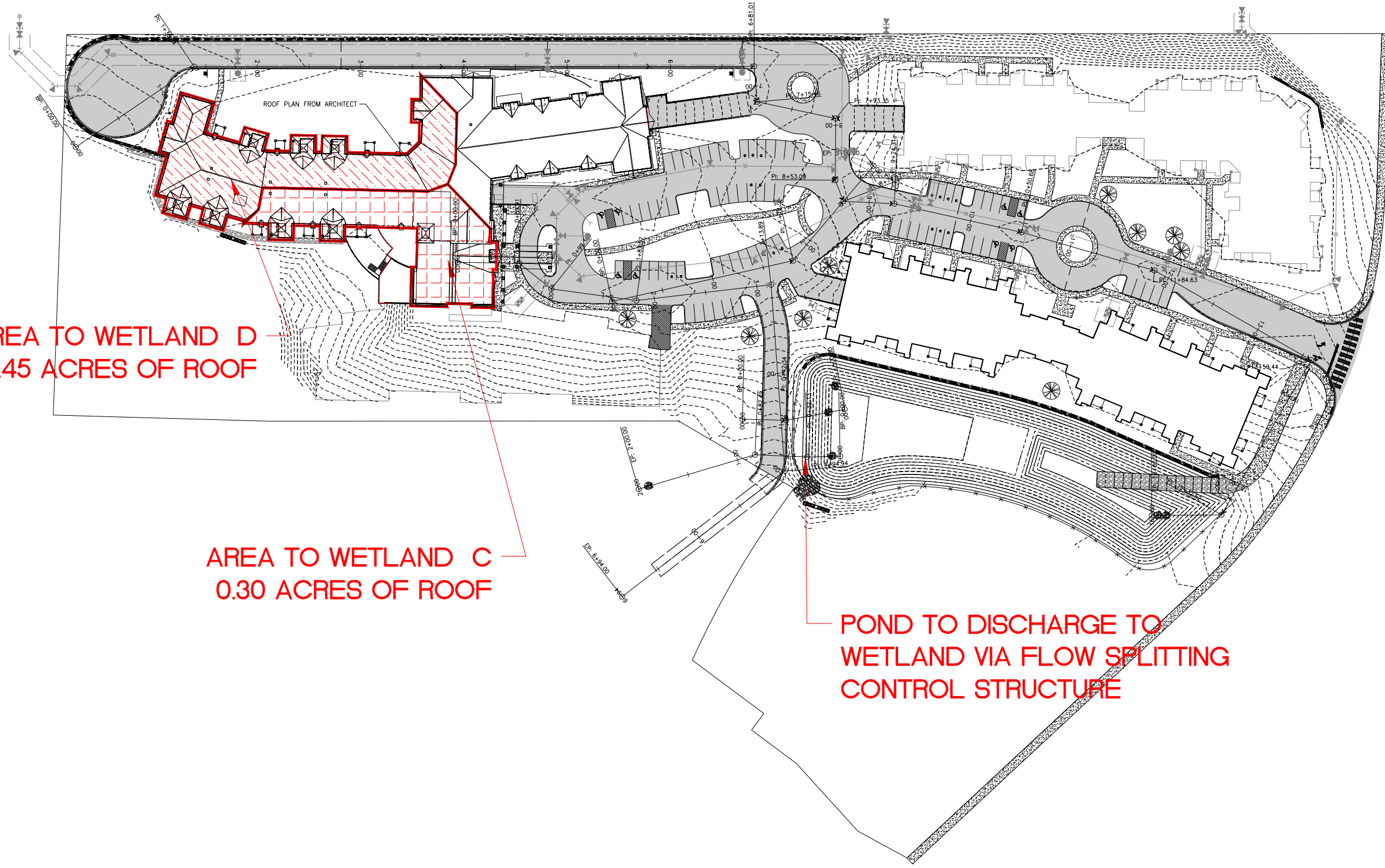
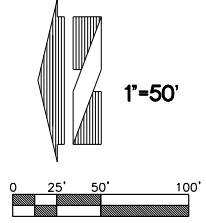

AREA TO WETLAND D
0.45 ACRES OF ROOF

AREA TO WETLAND C
0.30 ACRES OF ROOF

POND TO DISCHARGE TO
WETLAND VIA FLOW SPLITTING
CONTROL STRUCTURE

BARGHAUSEN & ASSOCIATES
CONSULTING ENGINEERS, INC.
18215 72ND AVENUE SOUTH
KENT, WA 98032
(425)251-6222
(425)251-8782 FAX
CIVIL ENGINEERING, LAND PLANNING,
SURVEYING, ENVIRONMENTAL SERVICES

Designed CP
Drawn CK
Checked CP
Approved CP
Date 5/25/14

Scale:
Horizontal 1"=60'
Vertical N/A

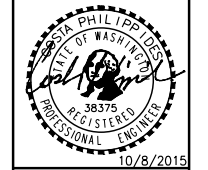

For:
WESLEY HOMES
PUYALLUP, WA

Title:
WETLAND DEVELOPED AREAS MAP
WESLEY HOMES
PUYALLUP, WA

Revision
No. Date By Ctd. Appr.

GRADING AND STORM DRAINAGE PLAN (NORTH)

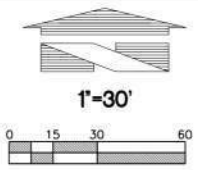

CATCH BASIN TABLE

- CB #9, TYPE 1,**
W/STANDARD GRATE
RIM = 465.30
IE=461.88 (6' W)
IE=461.88 (12' S)
- CB #11, TYPE 1,**
W/STANDARD GRATE
RIM = 465.30
IE=461.22 (6' SE)
IE=461.22 (12' S)
- CB #15, TYPE 1**
W/STANDARD GRATE
RIM = 457.00
IE=454.96 (8' S)
- CB #17, TYPE 2 48"**
W/STANDARD GRATE
RIM = 467.00
IE=455.77 (12' N)
IE=455.77 (6' NW)
IE=455.77 (12' S)
- CB #18, TYPE 2 48"**
W/STANDARD GRATE
RIM = 467.00
IE=456.97 (12' N)
IE=456.97 (12' S)
- CB #19, TYPE 2 48"**
W/STANDARD GRATE
RIM = 465.40
IE=458.43 (12' NW)
IE=458.43 (12' S)
- CB #20, TYPE 1,**
W/STANDARD GRATE
RIM = 462.00
IE=459.00 (12' SE)
- CO #5, 6" CLEANOUT**
ROOF DRAINS
RIM = 468.00
IE=456.07 (6' SE)
- CO #6, 6" CLEANOUT**
ROOF DRAINS
RIM = 468.00
IE=462.71 (6' E)
- CO #7, 6" CLEANOUT**
ROOF DRAINS
RIM = 457.00
IE=452.19 (6' N)
- CO #8, 6" CLEANOUT**
ROOF DRAINS
RIM = 457.00
IE=453.40 (6' NW)
- CO #9, 6" CLEANOUT**
ROOF DRAINS
RIM = 468.00
IE=461.65 (6' NW)
- STORMFILTER CB #22,**
W/STANDARD GRATE
RIM = 457.73
IE=453.62 (12' N)
IE=453.62 (12' S)
- YARD DRAIN #1,**
RIM = 455.03
IE=452.00 (6' S)
- YARD DRAIN #2,**
RIM = 456.00
IE=453.00 (6' SE)

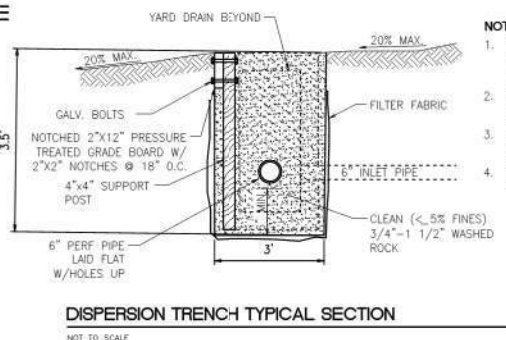

- NOTES:**
- THIS TRENCH SHALL BE CONSTRUCTED SO AS TO PREVENT POINT DISCHARGE AND/OR EROSION.
 - TRENCHES MAY BE PLACED NO CLOSER THAN 25 FEET TO ONE ANOTHER.
 - TRENCH AND GRADE BOARD MUST BE LEVEL ALIGN TO FOLLOW CONTOURS OF SITE.
 - GRADE BOARD SUPPORT POST SPACING 18" O.C.

REVISED PARCEL 1
PUYALLUP B.L.A.
NO. 06-84-007
A.F.N. 200608185003

- NOTE:**
- ALL EXPOSED SOIL AT FINAL GRADE SHALL BE STABILIZED IMMEDIATELY USING PERMANENT OR TEMPORARY MEASURES. EXPOSED SOILS WITH AN AREA GREATER THAN 5,000 SQUARE FEET THAT ARE SCHEDULED TO REMAIN UNWORKED FOR MORE THAN 24 HOURS AND EXPOSED AREAS OF LESS THAN 5,000 SQUARE FEET THAT WILL REMAIN UNWORKED FOR MORE THAN SEVEN (7) DAYS SHALL BE STABILIZED IMMEDIATELY.
 - ANY CURB, GUTTER, SIDEWALK, OR OTHER EXISTING IMPROVEMENTS WHICH ARE DAMAGED NOW OR DURING THE COURSE OF CONSTRUCTION, OR WHICH DO NOT MEET CURRENT CITY STANDARDS, SHALL BE REPLACED.

APPROVED
BY: CITY OF PUYALLUP
ENGINEERING SERVICES
DATE: _____
NOTE: THIS APPROVAL IS VOID AFTER 1 YEAR FROM APPROVAL DATE.
THE CITY WILL NOT BE RESPONSIBLE FOR ERRORS AND/OR OMISSIONS ON THESE PLANS.
FIELD CONDITIONS MAY DICTATE CHANGES TO THESE PLANS AS DETERMINED BY THE ENGINEERING SERVICES MANAGER.

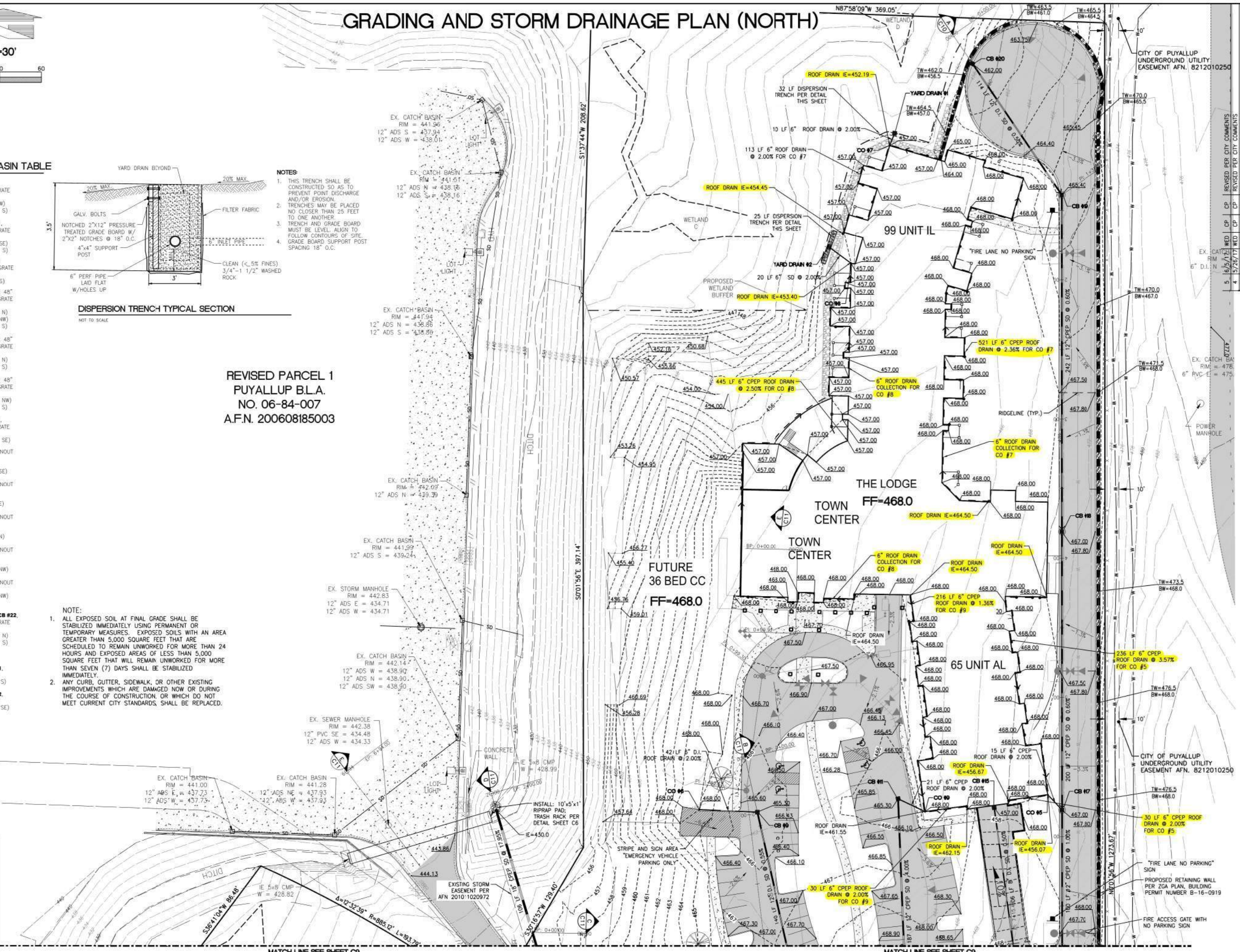

Revised Per City Comments	By	Date
5	CP	6/6/17
4	CP	5/26/17
3	CP	4/24/17

Title:
GRADING AND STORM DRAINAGE
PLAN (NORTH)
FOR
WESLEY HOMES
PUYALLUP, WA

For:
WESLEY HOMES
815 SOUTH 216TH STREET
DES MOINES, WA 98190
(206) 870-1209

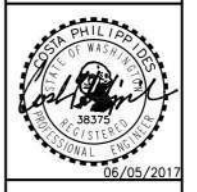

Scale: Horizontal 1"=30', Vertical N/A
Designed: CP
Drawn: CK
Checked: CP
Approved: CP
Date: 5/25/14

18215 72ND AVENUE SOUTH
KENT, WA 98032
(425)251-6222
(425)251-8782 FAX
CIVIL ENGINEERING, LAND PLANNING,
SURVEYING, ENVIRONMENTAL SERVICES



Job Number: 16718
Sheet: C8 of 24

**WETLAND FLOW DISTRIBUTION
CALCULATIONS**

WWHM2012

PROJECT REPORT

South Pond to Wetland A
5/26/2017

General Model Information

Project Name: 16718-South-Pond TO WETLAND
Site Name: Wesley Homes Puyallup
Site Address: 707 39th Ave. SE
City: Puyallup
Report Date: 5/26/2017
Gage:
Data Start: 10/01/1901
Data End: 09/30/2059
Timestep: 15 Minute
Precip Scale: 1.00
Version Date: 2016/02/25
Version: 4.2.12

POC Thresholds

Low Flow Threshold for POC1:	50 Percent of the 2 Year
High Flow Threshold for POC1:	50 Year

Landuse Basin Data
Predeveloped Land Use

Basin 1

Bypass:	No
GroundWater:	No
Pervious Land Use	acre
C, Forest, Flat	5.5
C, Pasture, Flat	1.46
Pervious Total	6.96
Impervious Land Use	acre
Impervious Total	0
Basin Total	6.96

Element Flows To:		
Surface	Interflow	Groundwater

Mitigated Land Use

Basin 1

Bypass:	No
GroundWater:	No
Pervious Land Use	acre
C, Forest, Flat	4.11
Pervious Total	4.11
Impervious Land Use	acre
ROOF TOPS FLAT	2.5
PARKING FLAT	3.49
Impervious Total	5.99
Basin Total	10.1

Element Flows To:

Surface	Interflow	Groundwater
SSD Table 1	SSD Table 1	

Lateral Basin 1

Bypass: No

GroundWater: No

Pervious Land Use acre
SAT IMP DIS FLAT .3

Element Flows To:
Surface Interflow Groundwater

Mitigated Routing

SSD Table 1

Depth: 6 ft.
Element Flows To:
Outlet 1 Outlet 2
Lateral Basin 1

SSD Table Hydraulic Table

Stage (feet)	Area (ac.)	Volume (ac-ft.)	Outlet Struct	Outlet Struct	NotUsed	NotUsed	NotUsed
0.000	0.432	0.000	0.000	0.000	0.000	0.000	0.000
0.100	0.438	0.044	0.013	0.006	0.000	0.000	0.000
0.200	0.444	0.088	0.019	0.008	0.000	0.000	0.000
0.300	0.450	0.132	0.023	0.010	0.000	0.000	0.000
0.400	0.456	0.178	0.027	0.012	0.000	0.000	0.000
0.500	0.462	0.224	0.030	0.013	0.000	0.000	0.000
0.600	0.468	0.270	0.033	0.014	0.000	0.000	0.000
0.700	0.474	0.317	0.035	0.016	0.000	0.000	0.000
0.800	0.481	0.365	0.038	0.017	0.000	0.000	0.000
0.900	0.487	0.413	0.040	0.018	0.000	0.000	0.000
1.000	0.493	0.462	0.042	0.019	0.000	0.000	0.000
1.100	0.499	0.512	0.044	0.020	0.000	0.000	0.000
1.200	0.505	0.562	0.046	0.020	0.000	0.000	0.000
1.300	0.511	0.613	0.048	0.021	0.000	0.000	0.000
1.400	0.517	0.664	0.050	0.022	0.000	0.000	0.000
1.500	0.524	0.716	0.052	0.023	0.000	0.000	0.000
1.600	0.530	0.769	0.054	0.024	0.000	0.000	0.000
1.700	0.536	0.822	0.055	0.024	0.000	0.000	0.000
1.800	0.542	0.876	0.057	0.025	0.000	0.000	0.000
1.900	0.548	0.931	0.058	0.026	0.000	0.000	0.000
2.000	0.555	0.986	0.060	0.026	0.000	0.000	0.000
2.100	0.561	1.042	0.061	0.027	0.000	0.000	0.000
2.200	0.567	1.098	0.063	0.028	0.000	0.000	0.000
2.300	0.574	1.155	0.064	0.028	0.000	0.000	0.000
2.400	0.580	1.213	0.066	0.029	0.000	0.000	0.000
2.500	0.586	1.271	0.067	0.030	0.000	0.000	0.000
2.600	0.593	1.330	0.068	0.030	0.000	0.000	0.000
2.700	0.599	1.390	0.070	0.031	0.000	0.000	0.000
2.800	0.606	1.450	0.071	0.031	0.000	0.000	0.000
2.900	0.612	1.511	0.072	0.032	0.000	0.000	0.000
3.000	0.618	1.572	0.073	0.032	0.000	0.000	0.000
3.100	0.625	1.635	0.075	0.033	0.000	0.000	0.000
3.200	0.631	1.697	0.076	0.033	0.000	0.000	0.000
3.300	0.638	1.761	0.077	0.034	0.000	0.000	0.000
3.400	0.644	1.825	0.078	0.034	0.000	0.000	0.000
3.500	0.651	1.890	0.079	0.035	0.000	0.000	0.000
3.600	0.657	1.955	0.080	0.572	0.000	0.000	0.000
3.700	0.664	2.021	0.082	1.495	0.000	0.000	0.000
3.800	0.670	2.088	0.083	2.607	0.000	0.000	0.000
3.900	0.677	2.155	0.084	3.751	0.000	0.000	0.000
4.000	0.683	2.223	0.085	4.769	0.000	0.000	0.000
4.100	0.690	2.292	0.086	5.556	0.000	0.000	0.000
4.200	0.697	2.361	0.087	6.063	0.000	0.000	0.000
4.300	0.703	2.431	0.088	6.437	0.000	0.000	0.000
4.400	0.710	2.502	0.089	7.067	0.000	0.000	0.000

4.500	0.717	2.573	0.090	8.681	0.000	0.000	0.000
4.600	0.724	2.645	0.091	12.45	0.000	0.000	0.000
4.700	0.730	2.718	0.092	20.10	0.000	0.000	0.000
4.800	0.737	2.791	0.093	34.00	0.000	0.000	0.000
4.900	0.744	2.865	0.094	57.34	0.000	0.000	0.000
5.000	0.750	2.940	0.095	94.21	0.000	0.000	0.000
5.100	0.757	3.015	0.598	149.7	0.000	0.000	0.000
5.200	0.764	3.091	1.501	230.3	0.000	0.000	0.000
5.300	0.771	3.168	2.599	343.6	0.000	0.000	0.000
5.400	0.777	3.246	3.731	498.7	0.000	0.000	0.000
5.500	0.784	3.324	4.739	706.5	0.000	0.000	0.000
5.600	0.791	3.402	5.502	979.7	0.000	0.000	0.000
5.700	0.798	3.482	5.994	1332.932	0.000	0.000	0.000
5.800	0.805	3.562	6.441	11.06	0.000	0.000	0.000
5.900	0.811	3.643	6.826	11.30	0.000	0.000	0.000
6.000	0.818	3.724	7.191	11.53	0.000	0.000	0.000

Outlet structure to wetland

Outlet Structure outlet: 0

Riser Height (ft)

Riser Diameter (in)

Riser Type

Notch Type

Notch Height (ft)

Notch Width (ft)

Orifice	Dia. (in)	Height (ft)
1	<input type="text" value="1.25"/>	<input type="text" value="0"/>
2	<input type="text" value="0"/>	<input type="text" value="0"/>
3	<input type="text" value="0"/>	<input type="text" value="0"/>

Outlet structure to ditch

Outlet Structure outlet: 1

Riser Height (ft)

Riser Diameter (in)

Riser Type

Notch Type

Notch Height (ft)

Notch Width (ft)

Orifice	Dia. (in)	Height (ft)
1	<input type="text" value="0.83"/>	<input type="text" value="0"/>
2	<input type="text" value="2.23"/>	<input type="text" value="3.535"/>
3	<input type="text" value="1.35"/>	<input type="text" value="4"/>

Analysis Results

POC 1

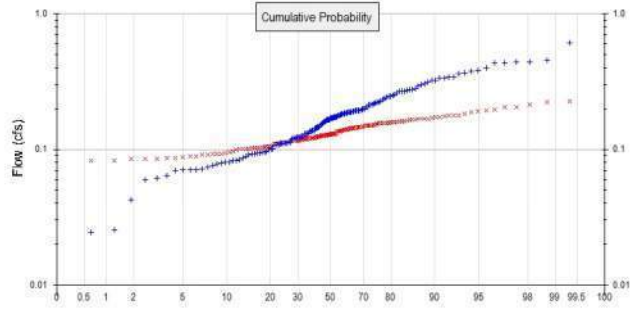
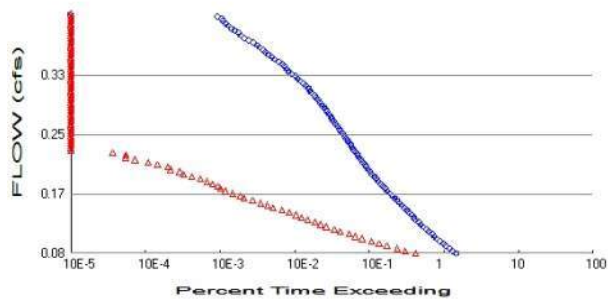

+ Predeveloped x Mitigated

Predeveloped Landuse Totals for POC #1

Total Pervious Area: 6.96
 Total Impervious Area: 0

Mitigated Landuse Totals for POC #1

Total Pervious Area: 4.41
 Total Impervious Area: 5.99

Flow Frequency Method: Log Pearson Type III 17B

Flow Frequency Return Periods for Predeveloped. POC #1

Return Period	Flow(cfs)
2 year	0.165836
5 year	0.255273
10 year	0.310331
25 year	0.37404
50 year	0.417245
100 year	0.457022

Flow Frequency Return Periods for Mitigated. POC #1

Return Period	Flow(cfs)
2 year	0.12985
5 year	0.157215
10 year	0.173743
25 year	0.193288
50 year	0.207067
100 year	0.220299

Annual Peaks

Annual Peaks for Predeveloped and Mitigated. POC #1

Year	Predeveloped	Mitigated
1902	0.122	0.130
1903	0.112	0.138
1904	0.191	0.156
1905	0.086	0.125
1906	0.042	0.093
1907	0.243	0.157
1908	0.187	0.124
1909	0.183	0.129
1910	0.245	0.150
1911	0.171	0.114

1912	0.610	0.224
1913	0.267	0.121
1914	0.073	0.101
1915	0.111	0.120
1916	0.173	0.140
1917	0.064	0.089
1918	0.189	0.127
1919	0.138	0.103
1920	0.170	0.128
1921	0.193	0.140
1922	0.189	0.140
1923	0.162	0.131
1924	0.078	0.093
1925	0.095	0.100
1926	0.166	0.116
1927	0.112	0.110
1928	0.136	0.130
1929	0.262	0.159
1930	0.177	0.168
1931	0.159	0.121
1932	0.124	0.117
1933	0.125	0.121
1934	0.343	0.166
1935	0.165	0.116
1936	0.149	0.120
1937	0.216	0.156
1938	0.145	0.116
1939	0.016	0.091
1940	0.156	0.150
1941	0.082	0.092
1942	0.224	0.151
1943	0.120	0.144
1944	0.222	0.205
1945	0.193	0.135
1946	0.113	0.130
1947	0.076	0.113
1948	0.337	0.144
1949	0.293	0.159
1950	0.092	0.086
1951	0.121	0.112
1952	0.439	0.225
1953	0.398	0.205
1954	0.152	0.127
1955	0.125	0.082
1956	0.071	0.078
1957	0.213	0.126
1958	0.434	0.175
1959	0.276	0.183
1960	0.083	0.105
1961	0.267	0.172
1962	0.154	0.125
1963	0.083	0.085
1964	0.088	0.172
1965	0.302	0.160
1966	0.094	0.104
1967	0.138	0.127
1968	0.144	0.111
1969	0.143	0.120

1970	0.214	0.128
1971	0.323	0.161
1972	0.215	0.157
1973	0.268	0.167
1974	0.162	0.135
1975	0.340	0.213
1976	0.192	0.158
1977	0.071	0.094
1978	0.312	0.179
1979	0.097	0.125
1980	0.183	0.145
1981	0.175	0.128
1982	0.079	0.114
1983	0.270	0.165
1984	0.124	0.149
1985	0.183	0.160
1986	0.171	0.121
1987	0.306	0.165
1988	0.195	0.127
1989	0.181	0.107
1990	0.204	0.116
1991	0.165	0.144
1992	0.232	0.149
1993	0.220	0.123
1994	0.324	0.146
1995	0.070	0.121
1996	0.363	0.159
1997	0.147	0.120
1998	0.166	0.146
1999	0.025	0.105
2000	0.131	0.143
2001	0.070	0.102
2002	0.254	0.190
2003	0.199	0.142
2004	0.189	0.140
2005	0.380	0.177
2006	0.111	0.102
2007	0.108	0.140
2008	0.178	0.116
2009	0.130	0.116
2010	0.109	0.137
2011	0.092	0.087
2012	0.130	0.136
2013	0.099	0.101
2014	0.080	0.088
2015	0.136	0.148
2016	0.061	0.110
2017	0.248	0.170
2018	0.452	0.169
2019	0.432	0.198
2020	0.146	0.150
2021	0.228	0.153
2022	0.101	0.099
2023	0.195	0.141
2024	0.440	0.193
2025	0.173	0.114
2026	0.276	0.143
2027	0.111	0.129

2028	0.095	0.082
2029	0.196	0.126
2030	0.337	0.164
2031	0.124	0.084
2032	0.071	0.095
2033	0.109	0.087
2034	0.101	0.104
2035	0.377	0.179
2036	0.206	0.131
2037	0.060	0.092
2038	0.172	0.145
2039	0.024	0.085
2040	0.095	0.119
2041	0.129	0.126
2042	0.368	0.168
2043	0.192	0.152
2044	0.250	0.157
2045	0.179	0.122
2046	0.198	0.145
2047	0.158	0.112
2048	0.187	0.097
2049	0.170	0.135
2050	0.122	0.130
2051	0.184	0.188
2052	0.110	0.113
2053	0.186	0.128
2054	0.235	0.156
2055	0.081	0.105
2056	0.091	0.101
2057	0.138	0.102
2058	0.173	0.117
2059	0.279	0.155

Ranked Annual Peaks

Ranked Annual Peaks for Predeveloped and Mitigated. POC #1

Rank	Predeveloped	Mitigated
1	0.6104	0.2248
2	0.4522	0.2241
3	0.4401	0.2125
4	0.4394	0.2055
5	0.4337	0.2052
6	0.4319	0.1975
7	0.3979	0.1930
8	0.3797	0.1900
9	0.3766	0.1876
10	0.3681	0.1826
11	0.3626	0.1790
12	0.3434	0.1787
13	0.3403	0.1771
14	0.3374	0.1751
15	0.3374	0.1725
16	0.3236	0.1716
17	0.3225	0.1701
18	0.3122	0.1687
19	0.3057	0.1684
20	0.3021	0.1677
21	0.2925	0.1672
22	0.2794	0.1661

23	0.2760	0.1650
24	0.2759	0.1649
25	0.2703	0.1636
26	0.2685	0.1609
27	0.2672	0.1601
28	0.2667	0.1599
29	0.2621	0.1593
30	0.2539	0.1593
31	0.2504	0.1588
32	0.2475	0.1579
33	0.2448	0.1573
34	0.2434	0.1572
35	0.2346	0.1569
36	0.2316	0.1562
37	0.2276	0.1558
38	0.2241	0.1557
39	0.2221	0.1552
40	0.2204	0.1530
41	0.2160	0.1518
42	0.2146	0.1507
43	0.2143	0.1504
44	0.2126	0.1503
45	0.2062	0.1495
46	0.2042	0.1494
47	0.1991	0.1493
48	0.1985	0.1478
49	0.1961	0.1463
50	0.1947	0.1461
51	0.1946	0.1453
52	0.1933	0.1450
53	0.1931	0.1448
54	0.1924	0.1444
55	0.1918	0.1444
56	0.1912	0.1439
57	0.1893	0.1433
58	0.1886	0.1427
59	0.1886	0.1422
60	0.1871	0.1411
61	0.1867	0.1404
62	0.1864	0.1404
63	0.1844	0.1402
64	0.1832	0.1399
65	0.1832	0.1396
66	0.1829	0.1383
67	0.1806	0.1370
68	0.1792	0.1359
69	0.1784	0.1351
70	0.1769	0.1350
71	0.1752	0.1348
72	0.1735	0.1313
73	0.1733	0.1309
74	0.1728	0.1304
75	0.1719	0.1303
76	0.1714	0.1303
77	0.1708	0.1302
78	0.1703	0.1294
79	0.1696	0.1286
80	0.1664	0.1284

81	0.1660	0.1283
82	0.1654	0.1282
83	0.1647	0.1279
84	0.1624	0.1272
85	0.1618	0.1272
86	0.1588	0.1269
87	0.1583	0.1268
88	0.1558	0.1260
89	0.1540	0.1260
90	0.1522	0.1259
91	0.1486	0.1255
92	0.1466	0.1249
93	0.1463	0.1249
94	0.1453	0.1235
95	0.1443	0.1227
96	0.1432	0.1224
97	0.1382	0.1214
98	0.1380	0.1214
99	0.1380	0.1210
100	0.1363	0.1209
101	0.1360	0.1206
102	0.1312	0.1200
103	0.1303	0.1198
104	0.1300	0.1196
105	0.1293	0.1195
106	0.1250	0.1191
107	0.1246	0.1174
108	0.1244	0.1170
109	0.1238	0.1165
110	0.1236	0.1164
111	0.1224	0.1163
112	0.1216	0.1160
113	0.1206	0.1156
114	0.1199	0.1156
115	0.1131	0.1139
116	0.1122	0.1137
117	0.1116	0.1137
118	0.1115	0.1133
119	0.1108	0.1128
120	0.1105	0.1122
121	0.1104	0.1115
122	0.1088	0.1108
123	0.1085	0.1099
124	0.1084	0.1095
125	0.1014	0.1066
126	0.1012	0.1052
127	0.0988	0.1050
128	0.0969	0.1045
129	0.0952	0.1043
130	0.0949	0.1036
131	0.0946	0.1026
132	0.0941	0.1019
133	0.0924	0.1017
134	0.0920	0.1016
135	0.0914	0.1009
136	0.0883	0.1008
137	0.0857	0.1008
138	0.0832	0.1002

139	0.0825	0.0993
140	0.0822	0.0971
141	0.0808	0.0951
142	0.0802	0.0943
143	0.0792	0.0932
144	0.0785	0.0932
145	0.0757	0.0920
146	0.0734	0.0919
147	0.0715	0.0908
148	0.0710	0.0891
149	0.0708	0.0880
150	0.0704	0.0875
151	0.0696	0.0867
152	0.0640	0.0860
153	0.0614	0.0855
154	0.0599	0.0846
155	0.0425	0.0844
156	0.0255	0.0824
157	0.0244	0.0823
158	0.0163	0.0782

Wetland Input Volumes

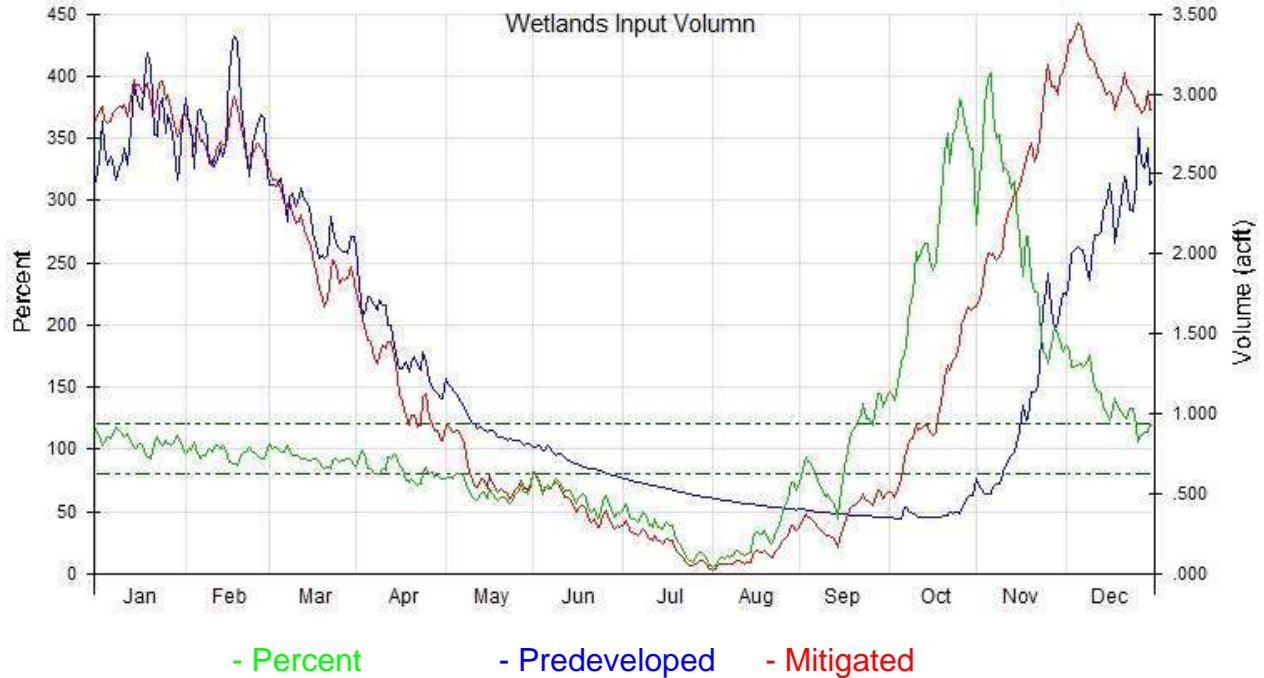

Wetlands Input Volumn for POC 1

Average Annual Volume (acft)

Series 1: 501 POC 1 Predeveloped flow

Series 2: 801 POC 1 Mitigated flow

Month	Series 1	Series 2	Percent	Pass/Fail
Jan	85.3335	90.8428	106.5	Pass
Feb	79.5097	76.9317	96.8	Pass
Mar	68.8048	64.5936	93.9	Pass
Apr	43.6854	36.5506	83.7	Fail
May	29.1500	19.8069	67.9	Fail
Jun	21.0202	13.2324	63.0	Fail
Jul	16.6179	5.6348	33.9	Fail
Aug	13.4496	3.7108	27.6	Fail
Sep	11.2476	10.6976	95.1	Pass
Oct	11.7787	31.6635	268.8	Fail
Nov	29.4595	72.7759	247.0	Fail
Dec	68.4567	96.4647	140.9	Fail

NOTE:

The overall volume for the entire year is within 9%, and as these are slope wetlands, what WWHM deems as "fail" is acceptable for this specific case.

Day	Predevel	Mitigated	Percent	Pass/Fail
Jan1	2.4484	2.8408	116.0	Pass
2	2.5746	2.8789	111.8	Pass
3	2.8255	2.9203	103.4	Pass
4	2.6709	2.8361	106.2	Pass
5	2.5611	2.8181	110.0	Pass
6	2.6126	2.8263	108.2	Pass
7	2.5910	2.8838	111.3	Pass
8	2.4586	2.9010	118.0	Pass
9	2.5406	2.9265	115.2	Pass
10	2.5885	2.9157	112.6	Pass
11	2.6628	2.9321	110.1	Pass
12	2.5558	2.8611	111.9	Pass
13	2.7867	2.9709	106.6	Pass
14	3.0538	3.0907	101.2	Pass

Model Default Modifications

Total of 0 changes have been made.

PERLND Changes

No PERLND changes have been made.

IMPLND Changes

No IMPLND changes have been made.

Appendix
Predeveloped Schematic



Mitigated Schematic

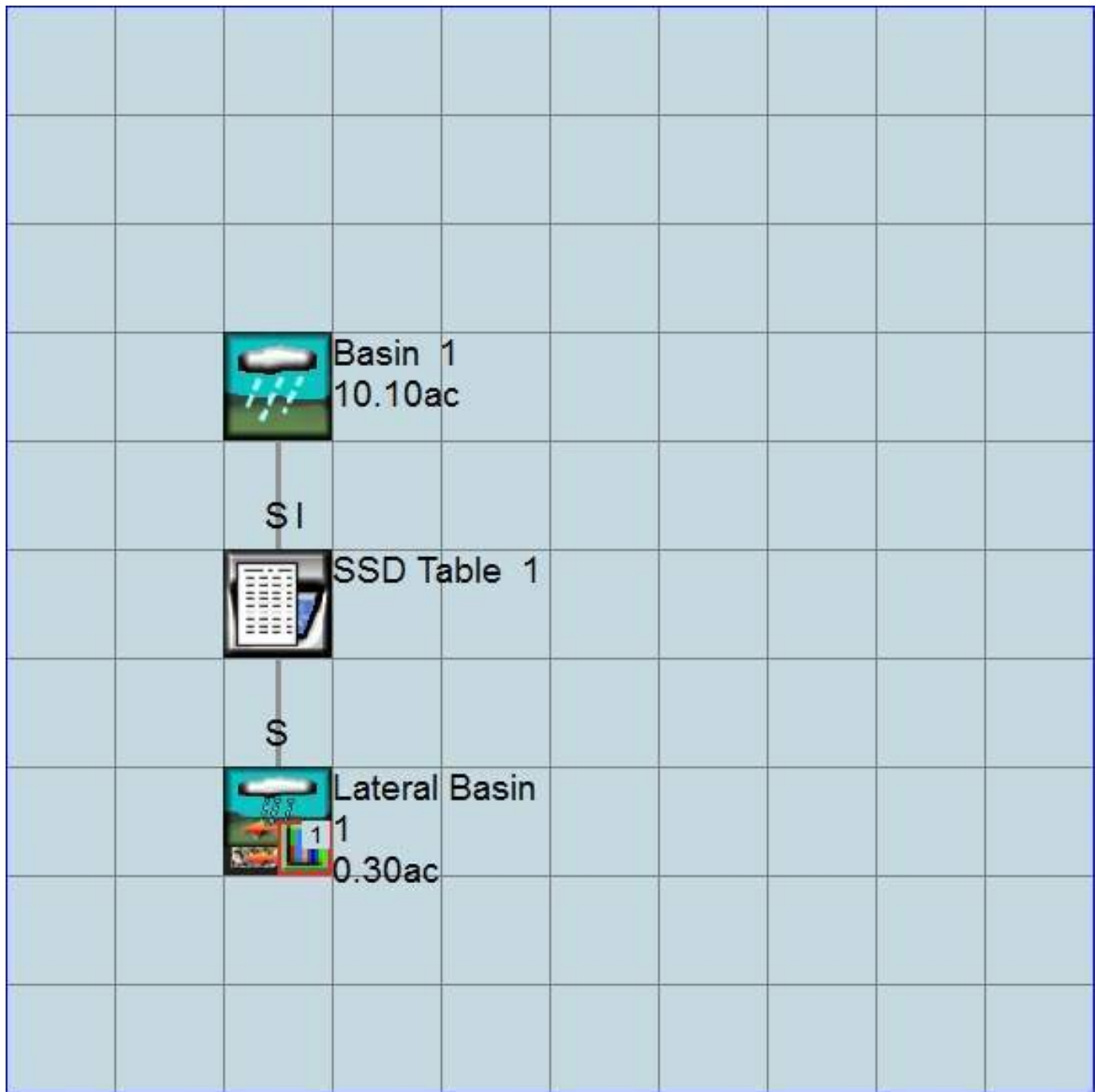

Disclaimer

Legal Notice

This program and accompanying documentation are provided 'as-is' without warranty of any kind. The entire risk regarding the performance and results of this program is assumed by End User. Clear Creek Solutions Inc. and the governmental licensee or sublicensees disclaim all warranties, either expressed or implied, including but not limited to implied warranties of program and accompanying documentation. In no event shall Clear Creek Solutions Inc. be liable for any damages whatsoever (including without limitation to damages for loss of business profits, loss of business information, business interruption, and the like) arising out of the use of, or inability to use this program even if Clear Creek Solutions Inc. or their authorized representatives have been advised of the possibility of such damages. Software Copyright © by : Clear Creek Solutions, Inc. 2005-2017; All Rights Reserved.

Clear Creek Solutions, Inc.
6200 Capitol Blvd. Ste F
Olympia, WA. 98501
Toll Free 1(866)943-0304
Local (360)943-0304

www.clearcreeksolutions.com

WWHM2012
PROJECT REPORT
WETLAND C

General Model Information

Project Name: 16718-Wetland
Site Name: Wesley Homes Puyallup
Site Address: 707 39th Ave. SE
City: Puyallup
Report Date: 3/27/2017
Gage:
Data Start: 10/01/1901
Data End: 09/30/2059
Timestep: 15 Minute
Precip Scale: 1.00
Version Date: 2016/02/25
Version: 4.2.12

POC Thresholds

Low Flow Threshold for POC1:	50 Percent of the 2 Year
High Flow Threshold for POC1:	50 Year

Landuse Basin Data

Predeveloped Land Use

Basin 1

Bypass:	No
GroundWater:	No
Pervious Land Use	acre
C, Forest, Flat	0.5
C, Pasture, Flat	0.13
Pervious Total	0.63
Impervious Land Use	acre
Impervious Total	0
Basin Total	0.63

Element Flows To:		
Surface	Interflow	Groundwater

Mitigated Land Use

Lateral I Basin 1

Bypass: No
Impervious Land Use acre
ROOF TOPS FLAT LAT 0.3
Element Flows To:
Outlet 1 Outlet 2
Lateral Basin 1

Lateral Basin 1

Bypass: No

GroundWater: No

Pervious Land Use acre
SAT IMP DIS FLAT .2

Element Flows To:
Surface Interflow Groundwater

Analysis Results

POC 1

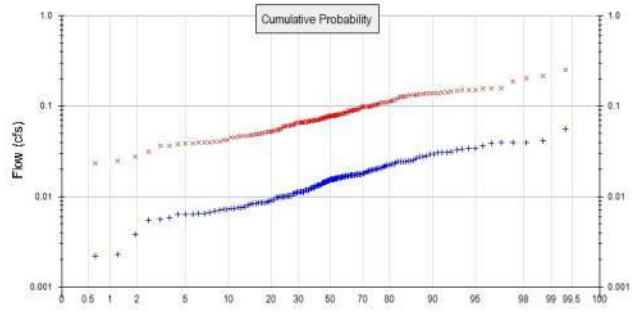
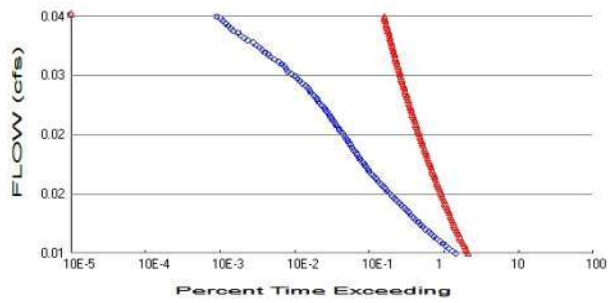

+ Predeveloped x Mitigated

Predeveloped Landuse Totals for POC #1

Total Pervious Area: 0.63
 Total Impervious Area: 0

Mitigated Landuse Totals for POC #1

Total Pervious Area: 0.2
 Total Impervious Area: 0.3

Flow Frequency Method: Log Pearson Type III 17B

Flow Frequency Return Periods for Predeveloped. POC #1

Return Period	Flow(cfs)
2 year	0.015
5 year	0.023095
10 year	0.028079
25 year	0.033846
50 year	0.037758
100 year	0.041359

Flow Frequency Return Periods for Mitigated. POC #1

Return Period	Flow(cfs)
2 year	0.077594
5 year	0.112632
10 year	0.13628
25 year	0.166469
50 year	0.189115
100 year	0.211863

Annual Peaks

Annual Peaks for Predeveloped and Mitigated. POC #1

Year	Predeveloped	Mitigated
1902	0.011	0.054
1903	0.010	0.036
1904	0.017	0.140
1905	0.008	0.061
1906	0.004	0.025
1907	0.022	0.098
1908	0.017	0.082
1909	0.017	0.082
1910	0.022	0.143
1911	0.016	0.084

1912	0.055	0.252
1913	0.024	0.083
1914	0.007	0.036
1915	0.010	0.046
1916	0.016	0.080
1917	0.006	0.042
1918	0.017	0.063
1919	0.012	0.045
1920	0.015	0.079
1921	0.017	0.067
1922	0.017	0.084
1923	0.015	0.085
1924	0.007	0.038
1925	0.009	0.052
1926	0.015	0.070
1927	0.010	0.048
1928	0.012	0.077
1929	0.024	0.127
1930	0.016	0.079
1931	0.014	0.071
1932	0.011	0.078
1933	0.011	0.065
1934	0.031	0.158
1935	0.015	0.068
1936	0.013	0.073
1937	0.020	0.110
1938	0.013	0.071
1939	0.001	0.023
1940	0.014	0.078
1941	0.007	0.047
1942	0.020	0.104
1943	0.011	0.078
1944	0.020	0.157
1945	0.017	0.061
1946	0.010	0.078
1947	0.007	0.050
1948	0.031	0.115
1949	0.026	0.096
1950	0.008	0.043
1951	0.011	0.049
1952	0.040	0.203
1953	0.036	0.188
1954	0.014	0.088
1955	0.011	0.053
1956	0.006	0.028
1957	0.019	0.069
1958	0.039	0.144
1959	0.025	0.133
1960	0.008	0.048
1961	0.024	0.098
1962	0.014	0.085
1963	0.007	0.040
1964	0.008	0.122
1965	0.027	0.127
1966	0.009	0.065
1967	0.013	0.070
1968	0.013	0.072
1969	0.013	0.091

1970	0.019	0.104
1971	0.029	0.132
1972	0.019	0.112
1973	0.024	0.100
1974	0.015	0.081
1975	0.031	0.153
1976	0.017	0.120
1977	0.006	0.060
1978	0.028	0.157
1979	0.009	0.069
1980	0.017	0.073
1981	0.016	0.062
1982	0.007	0.047
1983	0.024	0.098
1984	0.011	0.091
1985	0.017	0.098
1986	0.015	0.066
1987	0.028	0.090
1988	0.018	0.074
1989	0.016	0.055
1990	0.018	0.074
1991	0.015	0.067
1992	0.021	0.100
1993	0.020	0.066
1994	0.029	0.128
1995	0.006	0.039
1996	0.033	0.100
1997	0.013	0.069
1998	0.015	0.101
1999	0.002	0.038
2000	0.012	0.080
2001	0.006	0.062
2002	0.023	0.151
2003	0.018	0.073
2004	0.017	0.109
2005	0.034	0.152
2006	0.010	0.080
2007	0.010	0.081
2008	0.016	0.071
2009	0.012	0.067
2010	0.010	0.052
2011	0.008	0.049
2012	0.012	0.083
2013	0.009	0.071
2014	0.007	0.053
2015	0.012	0.132
2016	0.006	0.040
2017	0.022	0.111
2018	0.041	0.139
2019	0.039	0.137
2020	0.013	0.108
2021	0.021	0.101
2022	0.009	0.052
2023	0.018	0.075
2024	0.040	0.219
2025	0.016	0.066
2026	0.025	0.109
2027	0.010	0.088

2028	0.009	0.039
2029	0.018	0.082
2030	0.031	0.135
2031	0.011	0.050
2032	0.006	0.045
2033	0.010	0.041
2034	0.009	0.067
2035	0.034	0.131
2036	0.019	0.091
2037	0.005	0.040
2038	0.016	0.139
2039	0.002	0.023
2040	0.009	0.078
2041	0.012	0.067
2042	0.033	0.116
2043	0.017	0.102
2044	0.023	0.089
2045	0.016	0.076
2046	0.018	0.076
2047	0.014	0.070
2048	0.017	0.060
2049	0.015	0.092
2050	0.011	0.089
2051	0.017	0.139
2052	0.010	0.066
2053	0.017	0.059
2054	0.021	0.138
2055	0.007	0.047
2056	0.008	0.031
2057	0.012	0.055
2058	0.016	0.056
2059	0.025	0.147

Ranked Annual Peaks

Ranked Annual Peaks for Predeveloped and Mitigated. POC #1

Rank	Predeveloped	Mitigated
1	0.0551	0.2516
2	0.0409	0.2190
3	0.0398	0.2035
4	0.0397	0.1883
5	0.0393	0.1582
6	0.0390	0.1574
7	0.0360	0.1570
8	0.0343	0.1526
9	0.0341	0.1517
10	0.0333	0.1505
11	0.0328	0.1469
12	0.0311	0.1441
13	0.0308	0.1430
14	0.0305	0.1405
15	0.0305	0.1393
16	0.0293	0.1393
17	0.0292	0.1385
18	0.0283	0.1383
19	0.0276	0.1369
20	0.0273	0.1350
21	0.0265	0.1334
22	0.0253	0.1323

23	0.0250	0.1320
24	0.0250	0.1308
25	0.0245	0.1280
26	0.0243	0.1274
27	0.0242	0.1270
28	0.0241	0.1224
29	0.0237	0.1196
30	0.0229	0.1159
31	0.0227	0.1150
32	0.0224	0.1119
33	0.0222	0.1111
34	0.0220	0.1103
35	0.0212	0.1091
36	0.0210	0.1089
37	0.0206	0.1081
38	0.0203	0.1043
39	0.0201	0.1037
40	0.0199	0.1024
41	0.0195	0.1011
42	0.0194	0.1009
43	0.0194	0.0999
44	0.0192	0.0998
45	0.0187	0.0995
46	0.0185	0.0982
47	0.0180	0.0980
48	0.0180	0.0979
49	0.0177	0.0977
50	0.0176	0.0955
51	0.0176	0.0922
52	0.0175	0.0912
53	0.0175	0.0909
54	0.0174	0.0905
55	0.0174	0.0898
56	0.0173	0.0892
57	0.0171	0.0891
58	0.0171	0.0884
59	0.0171	0.0881
60	0.0169	0.0854
61	0.0169	0.0850
62	0.0169	0.0835
63	0.0167	0.0835
64	0.0166	0.0832
65	0.0166	0.0825
66	0.0165	0.0823
67	0.0163	0.0823
68	0.0162	0.0822
69	0.0161	0.0810
70	0.0160	0.0806
71	0.0158	0.0804
72	0.0157	0.0802
73	0.0157	0.0802
74	0.0156	0.0790
75	0.0155	0.0787
76	0.0155	0.0781
77	0.0155	0.0780
78	0.0154	0.0778
79	0.0153	0.0777
80	0.0150	0.0776

81	0.0150	0.0771
82	0.0150	0.0763
83	0.0149	0.0761
84	0.0147	0.0748
85	0.0146	0.0744
86	0.0144	0.0743
87	0.0143	0.0735
88	0.0141	0.0734
89	0.0139	0.0728
90	0.0138	0.0715
91	0.0134	0.0714
92	0.0133	0.0709
93	0.0132	0.0709
94	0.0131	0.0706
95	0.0131	0.0701
96	0.0129	0.0700
97	0.0125	0.0699
98	0.0125	0.0693
99	0.0125	0.0692
100	0.0123	0.0692
101	0.0123	0.0681
102	0.0119	0.0671
103	0.0118	0.0670
104	0.0118	0.0667
105	0.0117	0.0666
106	0.0113	0.0666
107	0.0113	0.0665
108	0.0113	0.0663
109	0.0112	0.0660
110	0.0112	0.0657
111	0.0111	0.0654
112	0.0110	0.0651
113	0.0109	0.0631
114	0.0109	0.0617
115	0.0102	0.0615
116	0.0101	0.0607
117	0.0101	0.0605
118	0.0101	0.0602
119	0.0100	0.0596
120	0.0100	0.0591
121	0.0100	0.0556
122	0.0098	0.0554
123	0.0098	0.0549
124	0.0098	0.0542
125	0.0092	0.0532
126	0.0092	0.0527
127	0.0089	0.0524
128	0.0088	0.0523
129	0.0086	0.0516
130	0.0086	0.0498
131	0.0085	0.0496
132	0.0085	0.0488
133	0.0084	0.0487
134	0.0083	0.0484
135	0.0083	0.0479
136	0.0080	0.0469
137	0.0077	0.0467
138	0.0075	0.0465

139	0.0075	0.0458
140	0.0074	0.0453
141	0.0073	0.0450
142	0.0073	0.0426
143	0.0072	0.0419
144	0.0071	0.0406
145	0.0068	0.0405
146	0.0066	0.0397
147	0.0065	0.0395
148	0.0064	0.0392
149	0.0064	0.0389
150	0.0064	0.0384
151	0.0063	0.0377
152	0.0058	0.0364
153	0.0056	0.0362
154	0.0054	0.0311
155	0.0038	0.0276
156	0.0023	0.0247
157	0.0022	0.0232
158	0.0015	0.0232

Appendix
Predeveloped Schematic



Mitigated Schematic

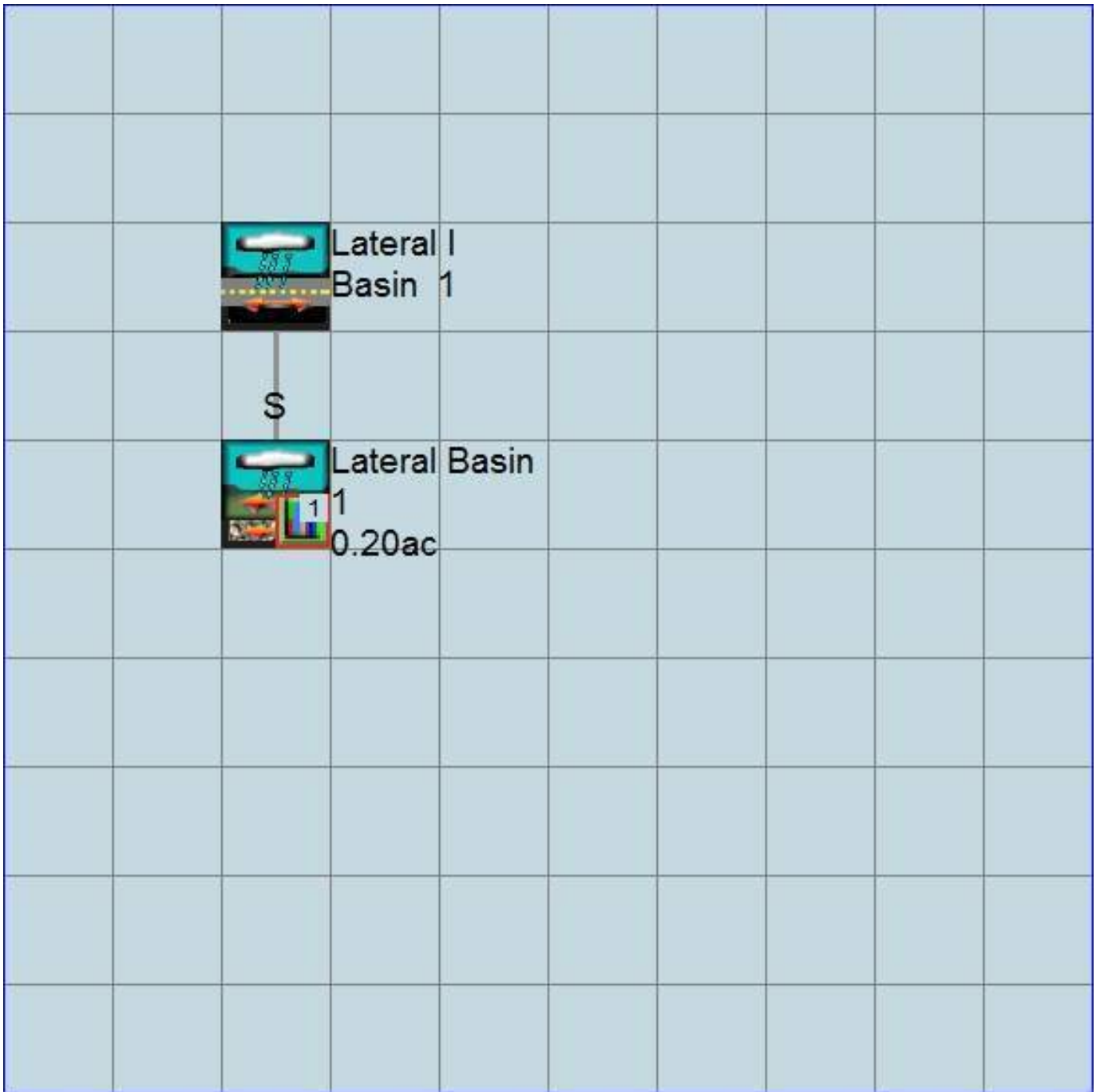

Disclaimer

Legal Notice

This program and accompanying documentation are provided 'as-is' without warranty of any kind. The entire risk regarding the performance and results of this program is assumed by End User. Clear Creek Solutions Inc. and the governmental licensee or sublicensees disclaim all warranties, either expressed or implied, including but not limited to implied warranties of program and accompanying documentation. In no event shall Clear Creek Solutions Inc. be liable for any damages whatsoever (including without limitation to damages for loss of business profits, loss of business information, business interruption, and the like) arising out of the use of, or inability to use this program even if Clear Creek Solutions Inc. or their authorized representatives have been advised of the possibility of such damages. Software Copyright © by : Clear Creek Solutions, Inc. 2005-2017; All Rights Reserved.

Clear Creek Solutions, Inc.
6200 Capitol Blvd. Ste F
Olympia, WA. 98501
Toll Free 1(866)943-0304
Local (360)943-0304

www.clearcreeksolutions.com

WWHM2012
PROJECT REPORT
WETLAND D

General Model Information

Project Name: 16718-Wetland
Site Name: Wesley Homes Puyallup
Site Address: 707 39th Ave. SE
City: Puyallup
Report Date: 3/27/2017
Gage:
Data Start: 10/01/1901
Data End: 09/30/2059
Timestep: 15 Minute
Precip Scale: 1.00
Version Date: 2016/02/25
Version: 4.2.12

POC Thresholds

Low Flow Threshold for POC1:	50 Percent of the 2 Year
High Flow Threshold for POC1:	50 Year

Landuse Basin Data

Predeveloped Land Use

Basin 1

Bypass: No

GroundWater: No

Pervious Land Use acre

C, Forest, Flat 0.75

C, Pasture, Flat 0.15

Pervious Total 0.9

Impervious Land Use acre

Impervious Total 0

Basin Total 0.9

Element Flows To:

Surface

Interflow

Groundwater

Mitigated Land Use

Lateral I Basin 1

Bypass: No
Impervious Land Use acre
ROOF TOPS FLAT LAT 0.45
Element Flows To:
Outlet 1 Outlet 2
Lateral Basin 1

Lateral Basin 1

Bypass: No

GroundWater: No

Pervious Land Use acre
SAT IMP DIS FLAT .2

Element Flows To:
Surface Interflow Groundwater

Analysis Results

POC 1

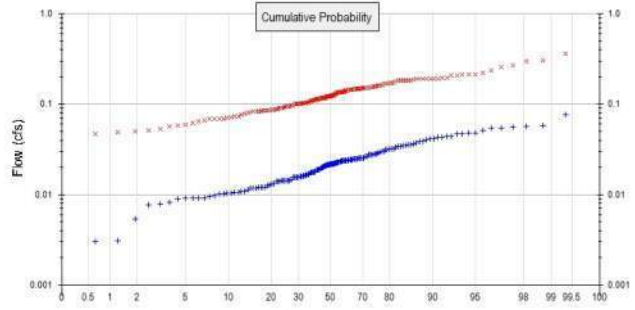
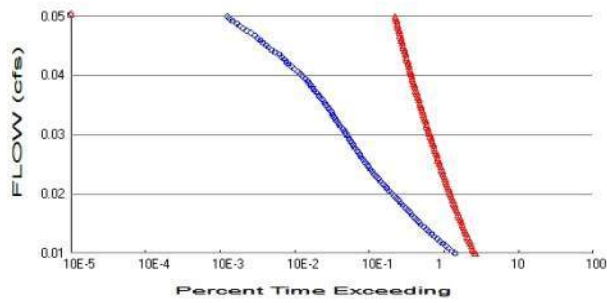

+ Predeveloped x Mitigated

Predeveloped Landuse Totals for POC #1

Total Pervious Area: 0.9
 Total Impervious Area: 0

Mitigated Landuse Totals for POC #1

Total Pervious Area: 0.2
 Total Impervious Area: 0.45

Flow Frequency Method: Log Pearson Type III 17B

Flow Frequency Return Periods for Predeveloped. POC #1

Return Period	Flow(cfs)
2 year	0.021451
5 year	0.032793
10 year	0.039534
25 year	0.04708
50 year	0.052034
100 year	0.056473

Flow Frequency Return Periods for Mitigated. POC #1

Return Period	Flow(cfs)
2 year	0.122818
5 year	0.170144
10 year	0.200266
25 year	0.236983
50 year	0.263423
100 year	0.289144

Annual Peaks

Annual Peaks for Predeveloped and Mitigated. POC #1

Year	Predeveloped	Mitigated
1902	0.016	0.093
1903	0.014	0.062
1904	0.024	0.194
1905	0.011	0.086
1906	0.005	0.047
1907	0.031	0.169
1908	0.024	0.112
1909	0.024	0.147
1910	0.032	0.190
1911	0.022	0.143

1912	0.076	0.360
1913	0.034	0.111
1914	0.009	0.049
1915	0.014	0.083
1916	0.022	0.111
1917	0.008	0.058
1918	0.024	0.113
1919	0.018	0.068
1920	0.022	0.117
1921	0.025	0.118
1922	0.024	0.144
1923	0.021	0.115
1924	0.010	0.079
1925	0.012	0.073
1926	0.021	0.111
1927	0.014	0.086
1928	0.018	0.104
1929	0.034	0.183
1930	0.023	0.110
1931	0.020	0.123
1932	0.016	0.125
1933	0.016	0.101
1934	0.044	0.209
1935	0.021	0.123
1936	0.019	0.100
1937	0.028	0.183
1938	0.019	0.124
1939	0.002	0.051
1940	0.020	0.152
1941	0.011	0.083
1942	0.029	0.144
1943	0.015	0.161
1944	0.028	0.238
1945	0.025	0.096
1946	0.014	0.136
1947	0.010	0.098
1948	0.043	0.170
1949	0.037	0.156
1950	0.012	0.064
1951	0.016	0.069
1952	0.057	0.302
1953	0.051	0.266
1954	0.020	0.138
1955	0.016	0.072
1956	0.009	0.050
1957	0.027	0.109
1958	0.056	0.191
1959	0.036	0.190
1960	0.011	0.084
1961	0.034	0.152
1962	0.020	0.134
1963	0.011	0.071
1964	0.011	0.212
1965	0.039	0.170
1966	0.012	0.091
1967	0.018	0.108
1968	0.019	0.100
1969	0.018	0.123

1970	0.028	0.182
1971	0.042	0.191
1972	0.028	0.152
1973	0.035	0.167
1974	0.021	0.148
1975	0.044	0.260
1976	0.025	0.170
1977	0.009	0.091
1978	0.040	0.209
1979	0.012	0.118
1980	0.024	0.126
1981	0.023	0.086
1982	0.010	0.106
1983	0.035	0.145
1984	0.016	0.145
1985	0.024	0.136
1986	0.022	0.117
1987	0.039	0.153
1988	0.025	0.114
1989	0.023	0.094
1990	0.026	0.131
1991	0.021	0.145
1992	0.030	0.153
1993	0.028	0.120
1994	0.042	0.173
1995	0.009	0.080
1996	0.047	0.161
1997	0.019	0.101
1998	0.021	0.141
1999	0.003	0.086
2000	0.017	0.143
2001	0.009	0.084
2002	0.032	0.222
2003	0.026	0.117
2004	0.024	0.147
2005	0.048	0.212
2006	0.014	0.115
2007	0.014	0.152
2008	0.023	0.126
2009	0.017	0.101
2010	0.014	0.129
2011	0.012	0.066
2012	0.016	0.136
2013	0.013	0.100
2014	0.010	0.088
2015	0.017	0.180
2016	0.008	0.056
2017	0.032	0.149
2018	0.058	0.184
2019	0.055	0.212
2020	0.019	0.160
2021	0.029	0.155
2022	0.013	0.077
2023	0.025	0.103
2024	0.054	0.297
2025	0.022	0.096
2026	0.036	0.148
2027	0.014	0.136

2028	0.012	0.053
2029	0.025	0.149
2030	0.043	0.181
2031	0.016	0.069
2032	0.009	0.069
2033	0.014	0.060
2034	0.013	0.095
2035	0.048	0.183
2036	0.027	0.124
2037	0.008	0.074
2038	0.022	0.191
2039	0.003	0.047
2040	0.012	0.116
2041	0.017	0.137
2042	0.047	0.191
2043	0.025	0.157
2044	0.032	0.136
2045	0.023	0.135
2046	0.026	0.132
2047	0.020	0.104
2048	0.024	0.082
2049	0.022	0.159
2050	0.016	0.122
2051	0.024	0.192
2052	0.014	0.090
2053	0.024	0.105
2054	0.030	0.188
2055	0.010	0.084
2056	0.012	0.084
2057	0.018	0.102
2058	0.022	0.088
2059	0.036	0.194

Ranked Annual Peaks

Ranked Annual Peaks for Predeveloped and Mitigated. POC #1

Rank	Predeveloped	Mitigated
1	0.0763	0.3602
2	0.0582	0.3021
3	0.0565	0.2966
4	0.0559	0.2662
5	0.0548	0.2597
6	0.0541	0.2378
7	0.0513	0.2223
8	0.0484	0.2123
9	0.0477	0.2123
10	0.0471	0.2116
11	0.0466	0.2091
12	0.0443	0.2090
13	0.0439	0.1940
14	0.0435	0.1940
15	0.0434	0.1917
16	0.0417	0.1911
17	0.0416	0.1909
18	0.0403	0.1908
19	0.0391	0.1907
20	0.0389	0.1903
21	0.0375	0.1900
22	0.0360	0.1881

23	0.0356	0.1839
24	0.0355	0.1834
25	0.0348	0.1832
26	0.0345	0.1826
27	0.0344	0.1817
28	0.0343	0.1813
29	0.0337	0.1802
30	0.0323	0.1734
31	0.0320	0.1704
32	0.0319	0.1702
33	0.0316	0.1698
34	0.0313	0.1686
35	0.0302	0.1665
36	0.0299	0.1615
37	0.0293	0.1608
38	0.0288	0.1600
39	0.0283	0.1587
40	0.0280	0.1572
41	0.0278	0.1560
42	0.0276	0.1547
43	0.0275	0.1530
44	0.0274	0.1528
45	0.0265	0.1518
46	0.0263	0.1517
47	0.0255	0.1516
48	0.0255	0.1516
49	0.0253	0.1494
50	0.0251	0.1490
51	0.0250	0.1483
52	0.0249	0.1477
53	0.0248	0.1470
54	0.0248	0.1466
55	0.0247	0.1450
56	0.0244	0.1450
57	0.0243	0.1446
58	0.0243	0.1438
59	0.0241	0.1436
60	0.0240	0.1433
61	0.0239	0.1432
62	0.0238	0.1409
63	0.0238	0.1380
64	0.0236	0.1367
65	0.0235	0.1365
66	0.0235	0.1364
67	0.0232	0.1362
68	0.0231	0.1358
69	0.0229	0.1357
70	0.0228	0.1348
71	0.0225	0.1341
72	0.0223	0.1317
73	0.0223	0.1307
74	0.0222	0.1285
75	0.0220	0.1259
76	0.0219	0.1257
77	0.0218	0.1253
78	0.0218	0.1243
79	0.0218	0.1235
80	0.0213	0.1234

81	0.0212	0.1234
82	0.0212	0.1230
83	0.0211	0.1215
84	0.0209	0.1203
85	0.0207	0.1183
86	0.0204	0.1181
87	0.0203	0.1173
88	0.0200	0.1173
89	0.0198	0.1167
90	0.0196	0.1160
91	0.0191	0.1154
92	0.0189	0.1146
93	0.0188	0.1139
94	0.0186	0.1135
95	0.0186	0.1119
96	0.0183	0.1114
97	0.0177	0.1110
98	0.0177	0.1110
99	0.0177	0.1100
100	0.0175	0.1088
101	0.0173	0.1083
102	0.0168	0.1060
103	0.0167	0.1051
104	0.0166	0.1040
105	0.0163	0.1040
106	0.0160	0.1026
107	0.0160	0.1022
108	0.0159	0.1013
109	0.0158	0.1013
110	0.0157	0.1005
111	0.0157	0.1004
112	0.0156	0.1002
113	0.0155	0.1002
114	0.0154	0.0976
115	0.0144	0.0965
116	0.0144	0.0957
117	0.0143	0.0946
118	0.0143	0.0940
119	0.0142	0.0927
120	0.0142	0.0915
121	0.0141	0.0905
122	0.0140	0.0905
123	0.0139	0.0884
124	0.0139	0.0876
125	0.0131	0.0864
126	0.0130	0.0862
127	0.0127	0.0859
128	0.0124	0.0856
129	0.0121	0.0845
130	0.0121	0.0843
131	0.0121	0.0841
132	0.0121	0.0836
133	0.0118	0.0834
134	0.0118	0.0831
135	0.0117	0.0825
136	0.0113	0.0800
137	0.0109	0.0785
138	0.0107	0.0769

139	0.0106	0.0739
140	0.0106	0.0729
141	0.0103	0.0719
142	0.0102	0.0706
143	0.0102	0.0694
144	0.0100	0.0689
145	0.0097	0.0689
146	0.0095	0.0684
147	0.0092	0.0664
148	0.0091	0.0644
149	0.0091	0.0618
150	0.0090	0.0595
151	0.0088	0.0579
152	0.0081	0.0564
153	0.0078	0.0531
154	0.0077	0.0509
155	0.0054	0.0498
156	0.0031	0.0490
157	0.0030	0.0473
158	0.0020	0.0466

Appendix
Predeveloped Schematic



Mitigated Schematic

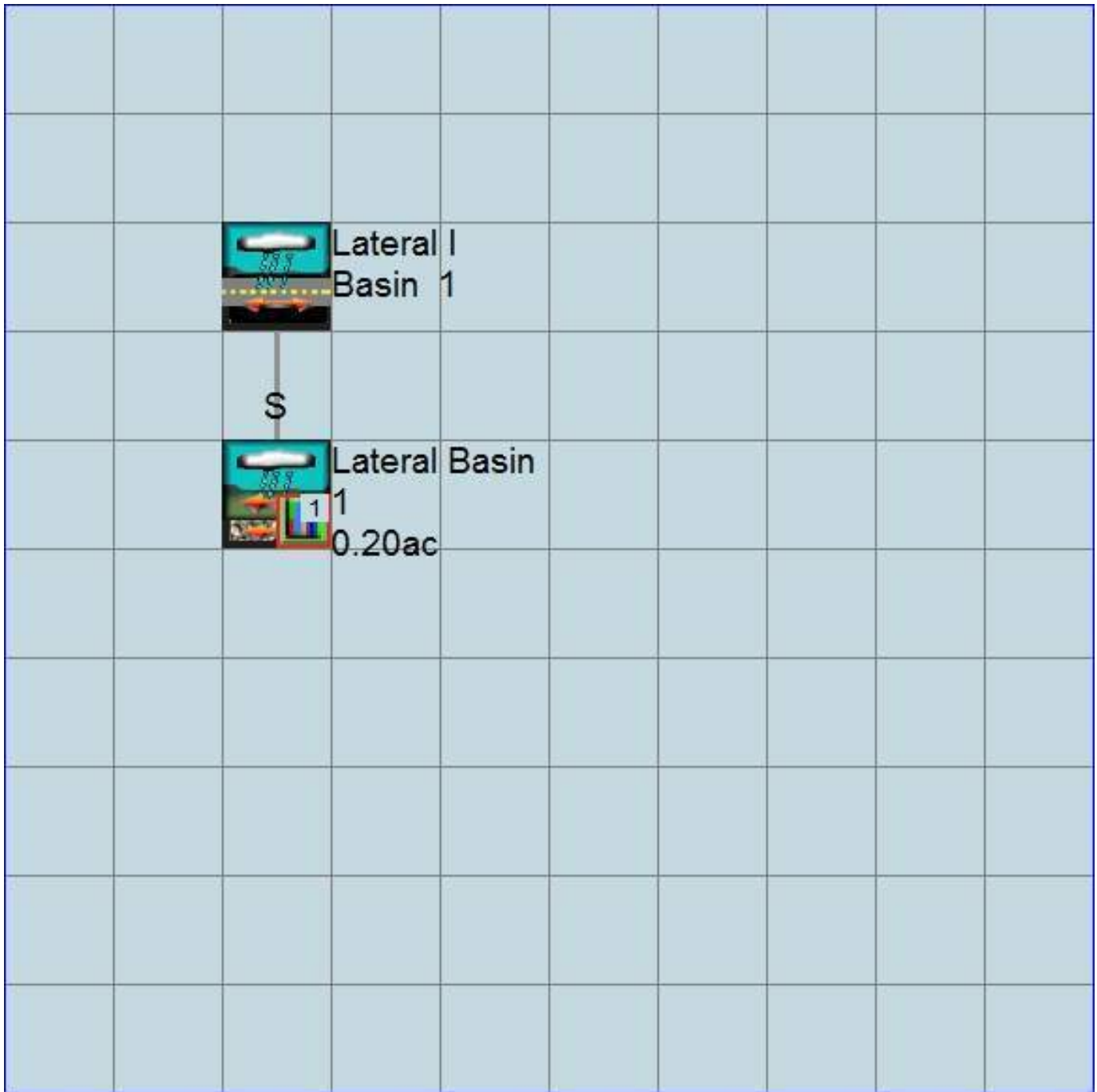

Disclaimer

Legal Notice

This program and accompanying documentation are provided 'as-is' without warranty of any kind. The entire risk regarding the performance and results of this program is assumed by End User. Clear Creek Solutions Inc. and the governmental licensee or sublicensees disclaim all warranties, either expressed or implied, including but not limited to implied warranties of program and accompanying documentation. In no event shall Clear Creek Solutions Inc. be liable for any damages whatsoever (including without limitation to damages for loss of business profits, loss of business information, business interruption, and the like) arising out of the use of, or inability to use this program even if Clear Creek Solutions Inc. or their authorized representatives have been advised of the possibility of such damages. Software Copyright © by : Clear Creek Solutions, Inc. 2005-2017; All Rights Reserved.

Clear Creek Solutions, Inc.
6200 Capitol Blvd. Ste F
Olympia, WA. 98501
Toll Free 1(866)943-0304
Local (360)943-0304

www.clearcreeksolutions.com

PREDEVELOPED BASIN MAP

PREDEVELOPED BASIN MAP FOR WESLEY HOMES PUYALLUP

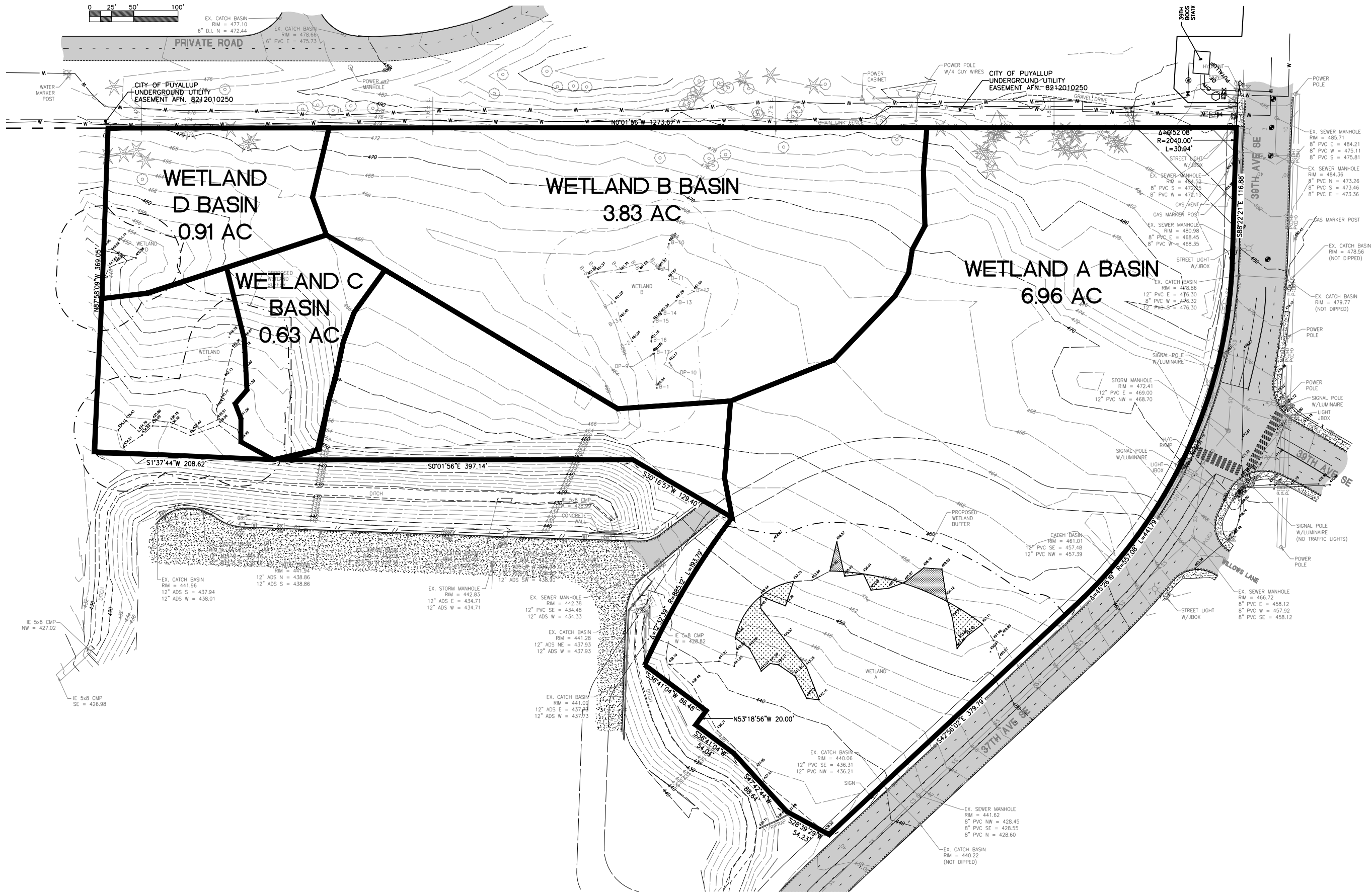
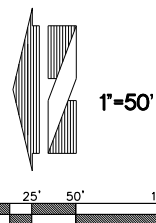

No.	Date	By	Chd.	Appr.	Revision

Title:
PREDEVELOPED BASIN MAP
WESLEY HOMES
PUYALLUP, WA

For:
WESLEY HOMES
PUYALLUP, WA

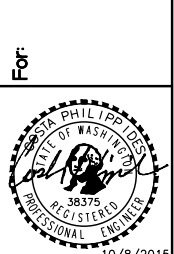

Scale:	Horizontal	1" = 60'
	Vertical	N/A
Designed	CP	
Drawn	CK	
Checked	CP	
Approved	CP	
Date	6/25/14	

18215 72ND AVENUE SOUTH
KENT, WA 98032
(425)251-6222
(425)251-8782 FAX
CIVIL ENGINEERING, LAND PLANNING,
SURVEYING, ENVIRONMENTAL SERVICES



Job Number
16718
Sheet
1 of 1

File:PA\16000a\16718-basin.mxd Date/Time:3/27/2017 3:31 PM Scale:1" = 1' WDU:JAP Xref: ---

BASIN MAP

PREDEVELOPED BASIN MAP FOR WESLEY HOMES PUYALLUP

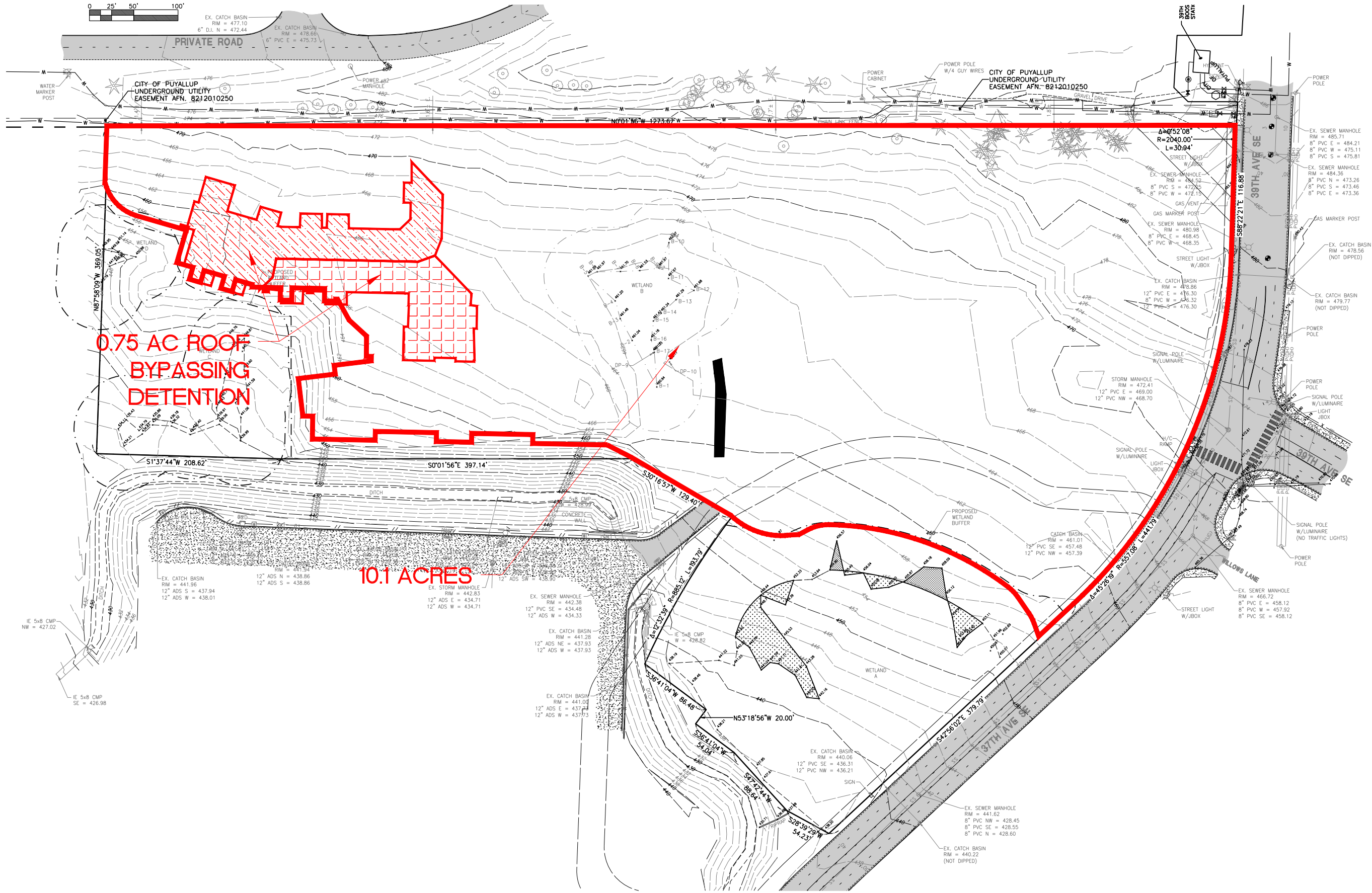
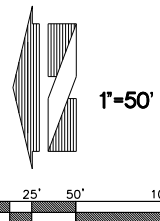

No.	Date	By	Chd.	Appr.	Revision

Title:
PREDEVELOPED BASIN MAP
WESLEY HOMES
PUYALLUP, WA

For:
WESLEY HOMES
PUYALLUP, WA

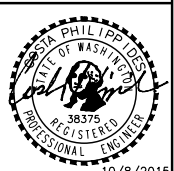

Scale:	Horizontal	1"=60'	Vertical	N/A
Designed	CP			
Drawn	CK			
Checked	CP			
Approved	CP			
Date	6/25/14			

18215 72ND AVENUE SOUTH
KENT, WA 98032
(425)251-6222
(425)251-8782 FAX
CIVIL ENGINEERING, LAND PLANNING,
SURVEYING, ENVIRONMENTAL SERVICES



Job Number
16718
Sheet
1 of **1**

File:PA\16000\16718\exhib\16718-basin_map.dwg Date/Time:5/26/2017 12:58 PM Scale:1" = 1' MOUNLAP Xref: ---

GRADING AND STORM DRAINAGE PLAN (NORTH)

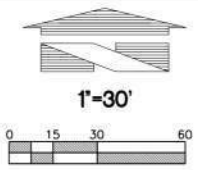

CATCH BASIN TABLE

- CB #9, TYPE 1,**
W/ STANDARD GRATE
RIM = 465.30
IE=461.88 (6' W)
IE=461.88 (12' S)
- CB #11, TYPE 1,**
W/ STANDARD GRATE
RIM = 465.30
IE=461.22 (6' SE)
IE=461.22 (12' S)
- CB #15, TYPE 1**
W/ STANDARD GRATE
RIM = 457.00
IE=454.96 (8' S)
- CB #17, TYPE 2 48"**
W/ STANDARD GRATE
RIM = 467.00
IE=455.77 (12' N)
IE=455.77 (6' NW)
IE=455.77 (12' S)
- CB #18, TYPE 2 48"**
W/ STANDARD GRATE
RIM = 467.00
IE=456.97 (12' N)
IE=456.97 (12' S)
- CB #19, TYPE 2 48"**
W/ STANDARD GRATE
RIM = 465.40
IE=458.43 (12' NW)
IE=458.43 (12' S)
- CB #20, TYPE 1,**
W/ STANDARD GRATE
RIM = 462.00
IE=459.00 (12' SE)
- CO #5, 6" CLEANOUT**
ROOF DRAINS
RIM = 468.00
IE=456.07 (6' SE)
- CO #6, 6" CLEANOUT**
ROOF DRAINS
RIM = 468.00
IE=462.71 (6' E)
- CO #7, 6" CLEANOUT**
ROOF DRAINS
RIM = 457.00
IE=452.19 (6' N)
- CO #8, 6" CLEANOUT**
ROOF DRAINS
RIM = 457.00
IE=453.40 (6' NW)
- CO #9, 6" CLEANOUT**
ROOF DRAINS
RIM = 468.00
IE=461.65 (6' NW)
- STORMFILTER CB #22,**
W/ STANDARD GRATE
RIM = 457.73
IE=453.62 (12' N)
IE=453.62 (12' S)
- YARD DRAIN #1,**
RIM = 455.03
IE=452.00 (6' S)
- YARD DRAIN #2,**
RIM = 456.00
IE=453.00 (6' SE)

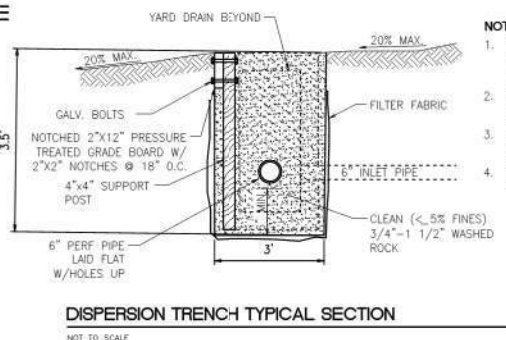

- NOTES:**
- THIS TRENCH SHALL BE CONSTRUCTED SO AS TO PREVENT POINT DISCHARGE AND/OR EROSION.
 - TRENCHES MAY BE PLACED NO CLOSER THAN 25 FEET TO ONE ANOTHER.
 - TRENCH AND GRADE BOARD MUST BE LEVEL ALIGN TO FOLLOW CONTOURS OF SITE.
 - GRADE BOARD SUPPORT POST SPACING 18" O.C.

REVISED PARCEL 1
PUYALLUP B.L.A.
NO. 06-84-007
A.F.N. 200608185003

- NOTE:**
- ALL EXPOSED SOIL AT FINAL GRADE SHALL BE STABILIZED IMMEDIATELY USING PERMANENT OR TEMPORARY MEASURES. EXPOSED SOILS WITH AN AREA GREATER THAN 5,000 SQUARE FEET THAT ARE SCHEDULED TO REMAIN UNWORKED FOR MORE THAN 24 HOURS AND EXPOSED AREAS OF LESS THAN 5,000 SQUARE FEET THAT WILL REMAIN UNWORKED FOR MORE THAN SEVEN (7) DAYS SHALL BE STABILIZED IMMEDIATELY.
 - ANY CURB, GUTTER, SIDEWALK, OR OTHER EXISTING IMPROVEMENTS WHICH ARE DAMAGED NOW OR DURING THE COURSE OF CONSTRUCTION, OR WHICH DO NOT MEET CURRENT CITY STANDARDS, SHALL BE REPLACED.

APPROVED
BY: CITY OF PUYALLUP
ENGINEERING SERVICES
DATE: _____
NOTE: THIS APPROVAL IS VOID AFTER 1 YEAR FROM APPROVAL DATE. THE CITY WILL NOT BE RESPONSIBLE FOR ERRORS AND/OR OMISSIONS ON THESE PLANS. FIELD CONDITIONS MAY DICTATE CHANGES TO THESE PLANS AS DETERMINED BY THE ENGINEERING SERVICES MANAGER.

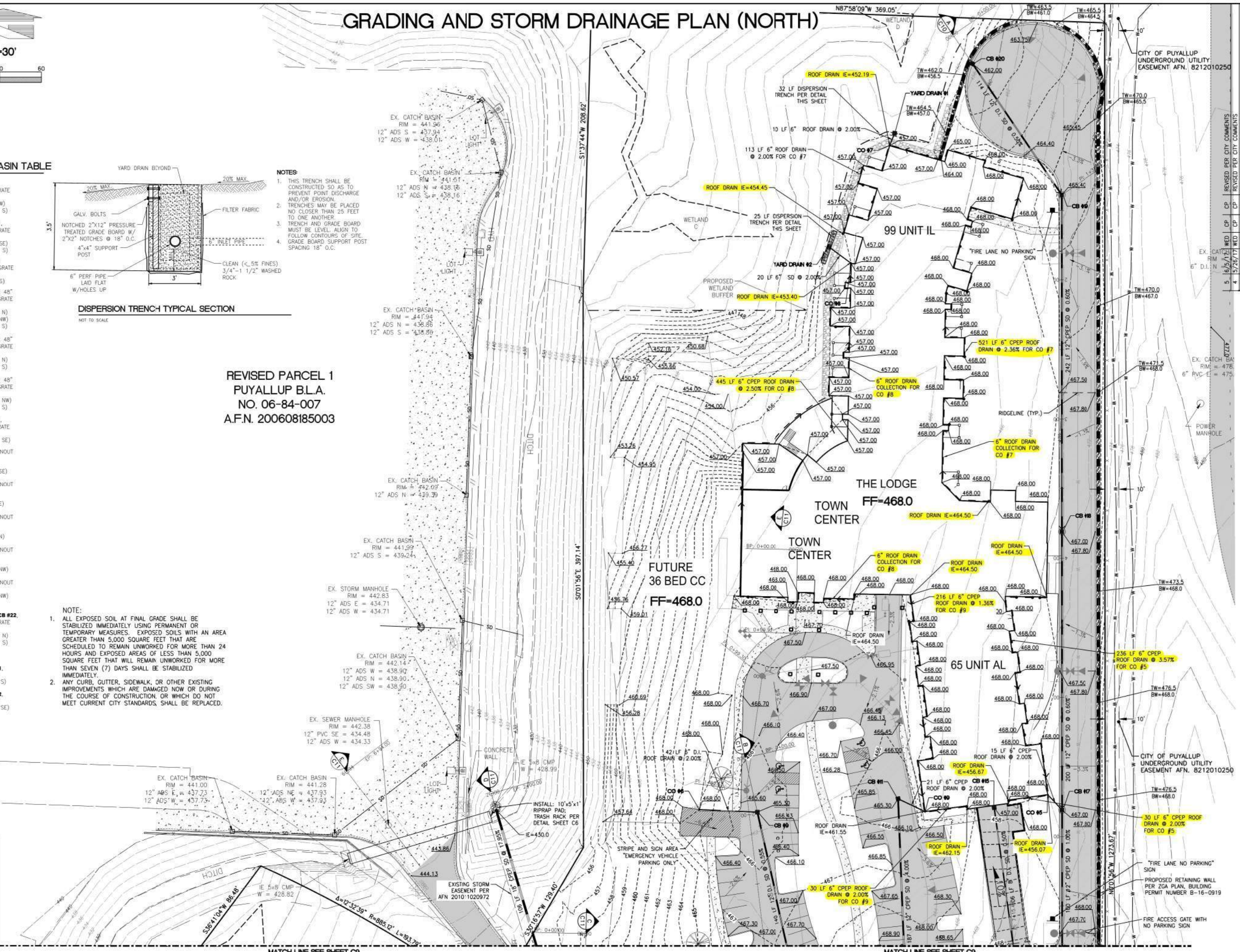

Revised Per City Comments	By	Date
5	CP	6/6/17
4	CP	5/26/17
3	CP	4/24/17

Title: GRADING AND STORM DRAINAGE PLAN (NORTH)
For: WESLEY HOMES
815 SOUTH 216TH STREET
DES MOINES, WA 98190
(206) 870-1209

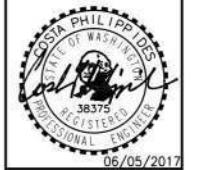

Scale: Horizontal 1"=30', Vertical N/A
Designed by: _____
Drawn by: _____
Checked by: _____
Approved by: _____
Date: 5/25/14



Job Number: 16718
Sheet: C8 of 24
18215 72ND AVENUE SOUTH
KENT, WA 98032
(425)251-6222
(425)251-8782 FAX
CIVIL ENGINEERING, LAND PLANNING,
SURVEYING, ENVIRONMENTAL SERVICES

FLOW CONTROL AND WATER QUALITY CALCULATIONS

SOUTH BASIN CALCULATIONS

WWHM2012

PROJECT REPORT

16718-Wesley Homes Puyallup
WQ and SSD Table - 5' Live Storage
May 22, 2017

General Model Information

Project Name: 16718FC&WQ
Site Name:
Site Address: NEC-5th Street SE/ 37th Ave. SE
City: Puyallup
Report Date: 5/22/2017
Gage:
Data Start: 10/01/1901
Data End: 09/30/2059
Timestep: 15 Minute
Precip Scale: 1.00
Version Date: 2016/02/25
Version: 4.2.12

POC Thresholds

Low Flow Threshold for POC1:	50 Percent of the 2 Year
High Flow Threshold for POC1:	50 Year

Landuse Basin Data

Predeveloped Land Use

Basin 1

Bypass:	No
GroundWater:	No
Pervious Land Use C, Forest, Flat	acre 10.85
Pervious Total	10.85
Impervious Land Use	acre
Impervious Total	0
Basin Total	10.85

Element Flows To:		
Surface	Interflow	Groundwater

Mitigated Land Use

Basin 1

Bypass:	No
GroundWater:	No
Pervious Land Use C, Forest, Flat	acre 4.11
Pervious Total	4.11
Impervious Land Use ROOF TOPS FLAT PARKING FLAT	acre 2.5 3.49
Impervious Total	5.99
Basin Total	10.1

Element Flows To:		
Surface	Interflow	Groundwater
SSD Table 1	SSD Table 1	

Basin 2

Bypass: Yes

GroundWater: No

Pervious Land Use acre

Pervious Total 0

Impervious Land Use acre
ROOF TOPS FLAT 0.75

Impervious Total 0.75

Basin Total 0.75

Element Flows To:
Surface

Interflow

Groundwater

Mitigated Routing

SSD Table 1

Depth: 6 ft.
 Element Flows To:
 Outlet 1 Outlet 2

SSD Table Hydraulic Table

Stage (feet)	Area (ac.)	Volume (ac-ft.)	Outlet Struct	NotUsed	NotUsed	NotUsed	NotUsed
0.000	0.432	0.000	0.000	0.000	0.000	0.000	0.000
0.100	0.438	0.044	0.019	0.000	0.000	0.000	0.000
0.200	0.444	0.088	0.027	0.000	0.000	0.000	0.000
0.300	0.450	0.132	0.033	0.000	0.000	0.000	0.000
0.400	0.456	0.178	0.039	0.000	0.000	0.000	0.000
0.500	0.462	0.224	0.043	0.000	0.000	0.000	0.000
0.600	0.468	0.270	0.047	0.000	0.000	0.000	0.000
0.700	0.474	0.317	0.051	0.000	0.000	0.000	0.000
0.800	0.481	0.365	0.055	0.000	0.000	0.000	0.000
0.900	0.487	0.413	0.058	0.000	0.000	0.000	0.000
1.000	0.493	0.462	0.061	0.000	0.000	0.000	0.000
1.100	0.499	0.512	0.064	0.000	0.000	0.000	0.000
1.200	0.505	0.562	0.067	0.000	0.000	0.000	0.000
1.300	0.511	0.613	0.070	0.000	0.000	0.000	0.000
1.400	0.517	0.664	0.072	0.000	0.000	0.000	0.000
1.500	0.524	0.716	0.075	0.000	0.000	0.000	0.000
1.600	0.530	0.769	0.077	0.000	0.000	0.000	0.000
1.700	0.536	0.822	0.080	0.000	0.000	0.000	0.000
1.800	0.542	0.876	0.082	0.000	0.000	0.000	0.000
1.900	0.548	0.931	0.084	0.000	0.000	0.000	0.000
2.000	0.555	0.986	0.086	0.000	0.000	0.000	0.000
2.100	0.561	1.042	0.088	0.000	0.000	0.000	0.000
2.200	0.567	1.098	0.091	0.000	0.000	0.000	0.000
2.300	0.574	1.155	0.093	0.000	0.000	0.000	0.000
2.400	0.580	1.213	0.095	0.000	0.000	0.000	0.000
2.500	0.586	1.271	0.097	0.000	0.000	0.000	0.000
2.600	0.593	1.330	0.098	0.000	0.000	0.000	0.000
2.700	0.599	1.390	0.100	0.000	0.000	0.000	0.000
2.800	0.606	1.450	0.102	0.000	0.000	0.000	0.000
2.900	0.612	1.511	0.104	0.000	0.000	0.000	0.000
3.000	0.618	1.572	0.106	0.000	0.000	0.000	0.000
3.100	0.625	1.635	0.108	0.000	0.000	0.000	0.000
3.200	0.631	1.697	0.109	0.000	0.000	0.000	0.000
3.300	0.638	1.761	0.111	0.000	0.000	0.000	0.000
3.400	0.644	1.825	0.113	0.000	0.000	0.000	0.000
3.500	0.651	1.890	0.114	0.000	0.000	0.000	0.000
3.600	0.657	1.955	0.141	0.000	0.000	0.000	0.000
3.700	0.664	2.021	0.167	0.000	0.000	0.000	0.000
3.800	0.670	2.088	0.184	0.000	0.000	0.000	0.000
3.900	0.677	2.155	0.199	0.000	0.000	0.000	0.000
4.000	0.683	2.223	0.211	0.000	0.000	0.000	0.000
4.100	0.690	2.292	0.238	0.000	0.000	0.000	0.000
4.200	0.697	2.361	0.255	0.000	0.000	0.000	0.000
4.300	0.703	2.431	0.269	0.000	0.000	0.000	0.000
4.400	0.710	2.502	0.283	0.000	0.000	0.000	0.000

4.500	0.717	2.573	0.295	0.000	0.000	0.000	0.000
4.600	0.724	2.645	0.307	0.000	0.000	0.000	0.000
4.700	0.730	2.718	0.318	0.000	0.000	0.000	0.000
4.800	0.737	2.791	0.328	0.000	0.000	0.000	0.000
4.900	0.744	2.865	0.338	0.000	0.000	0.000	0.000
5.000	0.750	2.940	0.348	0.000	0.000	0.000	0.000
5.100	0.757	3.015	0.859	0.000	0.000	0.000	0.000
5.200	0.764	3.091	1.770	0.000	0.000	0.000	0.000
5.300	0.771	3.168	2.876	0.000	0.000	0.000	0.000
5.400	0.777	3.246	4.015	0.000	0.000	0.000	0.000
5.500	0.784	3.324	5.031	0.000	0.000	0.000	0.000
5.600	0.791	3.402	5.801	0.000	0.000	0.000	0.000
5.700	0.798	3.482	6.300	0.000	0.000	0.000	0.000
5.800	0.805	3.562	6.754	0.000	0.000	0.000	0.000
5.900	0.811	3.643	7.146	0.000	0.000	0.000	0.000
6.000	0.818	3.724	7.517	0.000	0.000	0.000	0.000

Outlet Structure

outlet: 0

Riser Height (ft)

Riser Diameter (in)

Riser Type

Notch Type

Notch Height (ft)

Notch Width (ft)

Drifice	Dia. (in)	Height (ft)
1	<input type="text" value="1.5"/>	<input type="text" value="0"/>
2	<input type="text" value="2.23"/>	<input type="text" value="3.565"/>
3	<input type="text" value="1.35"/>	<input type="text" value="4"/>

Stage Frequency	
(feet)	1007
2 Year	= 2.8162
5 Year	= 3.6667
10 Year	= 4.1840
25 Year	= 4.7949
50 Year	= 5.2236
100 Year	= 5.6329

Analysis Results

POC 1

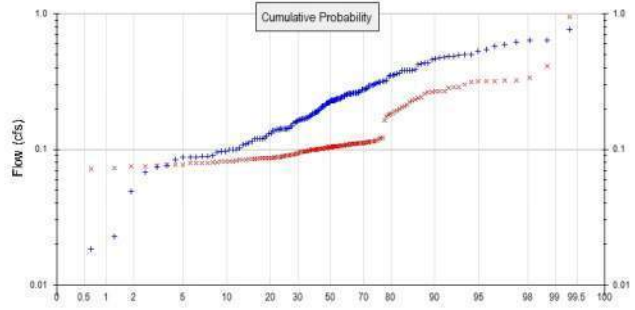
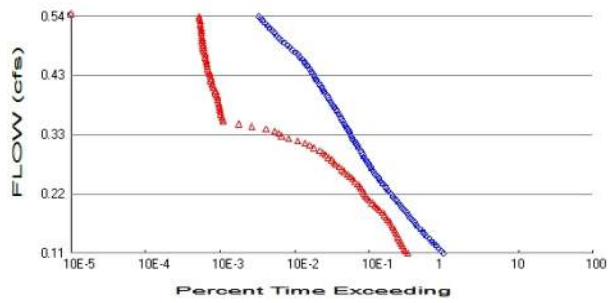

+ Predeveloped x Mitigated

Predeveloped Landuse Totals for POC #1

Total Pervious Area: 10.85
Total Impervious Area: 0

Mitigated Landuse Totals for POC #1

Total Pervious Area: 4.11
Total Impervious Area: 6.74

Flow Frequency Method: Log Pearson Type III 17B

Flow Frequency Return Periods for Predeveloped. POC #1

Return Period	Flow(cfs)
2 year	0.22864
5 year	0.355696
10 year	0.424734
25 year	0.495002
50 year	0.536767
100 year	0.57111

Flow Frequency Return Periods for Mitigated. POC #1

Return Period	Flow(cfs)
2 year	0.111101
5 year	0.168749
10 year	0.219816
25 year	0.302275
50 year	0.379115
100 year	0.471437

Annual Peaks

Annual Peaks for Predeveloped and Mitigated. POC #1

Year	Predeveloped	Mitigated
1902	0.168	0.106
1903	0.139	0.087
1904	0.228	0.099
1905	0.110	0.104
1906	0.049	0.075
1907	0.351	0.108
1908	0.260	0.093
1909	0.257	0.093
1910	0.354	0.106
1911	0.231	0.104

1912	0.761	0.113
1913	0.365	0.204
1914	0.089	0.073
1915	0.147	0.111
1916	0.228	0.099
1917	0.076	0.086
1918	0.244	0.231
1919	0.181	0.103
1920	0.233	0.101
1921	0.260	0.120
1922	0.261	0.105
1923	0.210	0.112
1924	0.096	0.087
1925	0.119	0.087
1926	0.221	0.087
1927	0.144	0.096
1928	0.177	0.102
1929	0.363	0.111
1930	0.233	0.099
1931	0.216	0.102
1932	0.169	0.112
1933	0.163	0.103
1934	0.479	0.318
1935	0.222	0.224
1936	0.193	0.106
1937	0.308	0.095
1938	0.188	0.101
1939	0.012	0.085
1940	0.208	0.121
1941	0.099	0.077
1942	0.314	0.321
1943	0.161	0.105
1944	0.296	0.176
1945	0.261	0.105
1946	0.141	0.077
1947	0.089	0.087
1948	0.492	0.112
1949	0.421	0.232
1950	0.119	0.088
1951	0.147	0.086
1952	0.641	0.289
1953	0.579	0.265
1954	0.209	0.121
1955	0.171	0.080
1956	0.084	0.076
1957	0.296	0.114
1958	0.619	0.338
1959	0.383	0.320
1960	0.102	0.081
1961	0.385	0.289
1962	0.207	0.103
1963	0.099	0.079
1964	0.109	0.084
1965	0.431	0.270
1966	0.121	0.098
1967	0.185	0.089
1968	0.189	0.106
1969	0.188	0.095

1970	0.295	0.111
1971	0.464	0.302
1972	0.301	0.111
1973	0.384	0.209
1974	0.208	0.101
1975	0.487	0.314
1976	0.258	0.106
1977	0.087	0.072
1978	0.434	0.268
1979	0.119	0.092
1980	0.246	0.101
1981	0.235	0.110
1982	0.096	0.079
1983	0.385	0.183
1984	0.157	0.096
1985	0.255	0.103
1986	0.229	0.110
1987	0.436	0.268
1988	0.277	0.180
1989	0.249	0.099
1990	0.282	0.107
1991	0.220	0.102
1992	0.315	0.241
1993	0.306	0.101
1994	0.458	0.114
1995	0.088	0.097
1996	0.502	0.321
1997	0.193	0.081
1998	0.229	0.105
1999	0.018	0.081
2000	0.174	0.109
2001	0.089	0.075
2002	0.319	0.101
2003	0.278	0.110
2004	0.255	0.100
2005	0.470	0.109
2006	0.142	0.086
2007	0.143	0.092
2008	0.243	0.103
2009	0.167	0.099
2010	0.142	0.112
2011	0.115	0.085
2012	0.166	0.091
2013	0.130	0.079
2014	0.097	0.083
2015	0.185	0.088
2016	0.074	0.089
2017	0.352	0.192
2018	0.641	0.952
2019	0.598	0.284
2020	0.195	0.086
2021	0.317	0.191
2022	0.131	0.090
2023	0.267	0.109
2024	0.502	0.099
2025	0.236	0.106
2026	0.385	0.164
2027	0.138	0.092

2028	0.120	0.079
2029	0.261	0.116
2030	0.483	0.214
2031	0.160	0.083
2032	0.087	0.082
2033	0.140	0.084
2034	0.138	0.090
2035	0.545	0.409
2036	0.283	0.108
2037	0.068	0.081
2038	0.226	0.110
2039	0.023	0.072
2040	0.126	0.096
2041	0.169	0.086
2042	0.531	0.317
2043	0.256	0.115
2044	0.346	0.199
2045	0.235	0.186
2046	0.276	0.258
2047	0.203	0.105
2048	0.263	0.098
2049	0.235	0.103
2050	0.169	0.089
2051	0.245	0.106
2052	0.141	0.097
2053	0.252	0.265
2054	0.320	0.242
2055	0.099	0.075
2056	0.111	0.084
2057	0.173	0.105
2058	0.219	0.108
2059	0.387	0.116

Ranked Annual Peaks

Ranked Annual Peaks for Predeveloped and Mitigated. POC #1

Rank	Predeveloped	Mitigated
1	0.7611	0.9523
2	0.6414	0.4092
3	0.6407	0.3378
4	0.6189	0.3215
5	0.5976	0.3206
6	0.5785	0.3197
7	0.5454	0.3184
8	0.5306	0.3170
9	0.5025	0.3143
10	0.5018	0.3017
11	0.4919	0.2892
12	0.4873	0.2891
13	0.4835	0.2840
14	0.4787	0.2699
15	0.4700	0.2680
16	0.4643	0.2679
17	0.4585	0.2653
18	0.4365	0.2645
19	0.4339	0.2575
20	0.4305	0.2419
21	0.4214	0.2411
22	0.3868	0.2320

23	0.3848	0.2306
24	0.3847	0.2239
25	0.3846	0.2142
26	0.3837	0.2087
27	0.3826	0.2045
28	0.3647	0.1991
29	0.3631	0.1924
30	0.3544	0.1912
31	0.3523	0.1863
32	0.3509	0.1835
33	0.3457	0.1801
34	0.3202	0.1759
35	0.3188	0.1643
36	0.3173	0.1212
37	0.3153	0.1209
38	0.3137	0.1199
39	0.3084	0.1164
40	0.3057	0.1157
41	0.3010	0.1148
42	0.2963	0.1140
43	0.2957	0.1140
44	0.2949	0.1130
45	0.2832	0.1125
46	0.2816	0.1123
47	0.2775	0.1120
48	0.2767	0.1120
49	0.2758	0.1114
50	0.2669	0.1113
51	0.2628	0.1110
52	0.2614	0.1109
53	0.2608	0.1104
54	0.2607	0.1103
55	0.2601	0.1102
56	0.2599	0.1099
57	0.2580	0.1093
58	0.2570	0.1092
59	0.2562	0.1089
60	0.2553	0.1080
61	0.2551	0.1078
62	0.2519	0.1077
63	0.2488	0.1070
64	0.2457	0.1064
65	0.2448	0.1061
66	0.2443	0.1060
67	0.2428	0.1060
68	0.2356	0.1060
69	0.2354	0.1058
70	0.2352	0.1056
71	0.2349	0.1053
72	0.2334	0.1051
73	0.2325	0.1050
74	0.2307	0.1050
75	0.2293	0.1046
76	0.2288	0.1046
77	0.2282	0.1043
78	0.2281	0.1035
79	0.2259	0.1034
80	0.2223	0.1033

81	0.2214	0.1031
82	0.2205	0.1031
83	0.2190	0.1029
84	0.2159	0.1029
85	0.2097	0.1019
86	0.2088	0.1019
87	0.2083	0.1017
88	0.2077	0.1012
89	0.2066	0.1011
90	0.2030	0.1010
91	0.1949	0.1009
92	0.1932	0.1008
93	0.1927	0.1006
94	0.1887	0.0997
95	0.1883	0.0995
96	0.1880	0.0992
97	0.1852	0.0991
98	0.1849	0.0990
99	0.1806	0.0989
100	0.1772	0.0988
101	0.1744	0.0984
102	0.1730	0.0983
103	0.1706	0.0971
104	0.1693	0.0966
105	0.1690	0.0962
106	0.1686	0.0962
107	0.1677	0.0960
108	0.1667	0.0954
109	0.1662	0.0954
110	0.1630	0.0934
111	0.1614	0.0925
112	0.1598	0.0920
113	0.1568	0.0918
114	0.1469	0.0918
115	0.1469	0.0914
116	0.1436	0.0901
117	0.1426	0.0897
118	0.1422	0.0894
119	0.1418	0.0893
120	0.1413	0.0889
121	0.1408	0.0877
122	0.1399	0.0877
123	0.1395	0.0873
124	0.1382	0.0873
125	0.1376	0.0868
126	0.1313	0.0867
127	0.1298	0.0866
128	0.1255	0.0864
129	0.1207	0.0861
130	0.1198	0.0860
131	0.1194	0.0858
132	0.1190	0.0855
133	0.1189	0.0848
134	0.1146	0.0846
135	0.1113	0.0845
136	0.1098	0.0843
137	0.1089	0.0842
138	0.1018	0.0832

139	0.0992	0.0831
140	0.0992	0.0817
141	0.0990	0.0815
142	0.0967	0.0812
143	0.0961	0.0812
144	0.0958	0.0805
145	0.0893	0.0801
146	0.0893	0.0793
147	0.0891	0.0792
148	0.0880	0.0789
149	0.0870	0.0786
150	0.0869	0.0775
151	0.0837	0.0772
152	0.0761	0.0764
153	0.0737	0.0753
154	0.0677	0.0748
155	0.0491	0.0746
156	0.0227	0.0729
157	0.0185	0.0721
158	0.0118	0.0716

Duration Flows

The Facility PASSED

Flow(cfs)	Predev	Mit	Percentage	Pass/Fail
0.1143	54603	18110	33	Pass
0.1186	50714	16753	33	Pass
0.1229	47246	16149	34	Pass
0.1271	43395	15507	35	Pass
0.1314	40531	14958	36	Pass
0.1357	37855	14421	38	Pass
0.1399	35429	13917	39	Pass
0.1442	32675	13329	40	Pass
0.1485	30565	12836	41	Pass
0.1527	28587	12393	43	Pass
0.1570	26808	11978	44	Pass
0.1613	24875	11440	45	Pass
0.1655	23473	10991	46	Pass
0.1698	22171	10482	47	Pass
0.1741	20648	9762	47	Pass
0.1783	19518	9263	47	Pass
0.1826	18437	8753	47	Pass
0.1869	17435	8260	47	Pass
0.1911	16183	7568	46	Pass
0.1954	15224	7075	46	Pass
0.1997	14393	6598	45	Pass
0.2039	13612	6094	44	Pass
0.2082	12692	5538	43	Pass
0.2125	12005	5176	43	Pass
0.2167	11357	4934	43	Pass
0.2210	10726	4734	44	Pass
0.2253	10005	4494	44	Pass
0.2295	9440	4319	45	Pass
0.2338	8958	4111	45	Pass
0.2381	8332	3856	46	Pass
0.2423	7895	3538	44	Pass
0.2466	7507	3305	44	Pass
0.2509	7113	3060	43	Pass
0.2551	6620	2809	42	Pass
0.2594	6294	2560	40	Pass
0.2637	6022	2390	39	Pass
0.2679	5762	2173	37	Pass
0.2722	5449	1962	36	Pass
0.2765	5217	1846	35	Pass
0.2807	4982	1722	34	Pass
0.2850	4703	1555	33	Pass
0.2893	4522	1434	31	Pass
0.2935	4356	1317	30	Pass
0.2978	4187	1201	28	Pass
0.3021	3958	1012	25	Pass
0.3063	3778	876	23	Pass
0.3106	3602	753	20	Pass
0.3149	3446	607	17	Pass
0.3191	3267	463	14	Pass
0.3234	3142	370	11	Pass
0.3277	3046	337	11	Pass
0.3319	2945	298	10	Pass
0.3362	2816	229	8	Pass

0.3405	2693	148	5	Pass
0.3447	2573	99	3	Pass
0.3490	2451	61	2	Pass
0.3533	2364	60	2	Pass
0.3575	2268	59	2	Pass
0.3618	2160	56	2	Pass
0.3661	2040	56	2	Pass
0.3703	1956	55	2	Pass
0.3746	1873	54	2	Pass
0.3789	1793	54	3	Pass
0.3831	1694	53	3	Pass
0.3874	1624	51	3	Pass
0.3917	1570	51	3	Pass
0.3960	1501	50	3	Pass
0.4002	1412	48	3	Pass
0.4045	1351	48	3	Pass
0.4088	1282	45	3	Pass
0.4130	1217	44	3	Pass
0.4173	1166	43	3	Pass
0.4216	1109	42	3	Pass
0.4258	1068	42	3	Pass
0.4301	1006	41	4	Pass
0.4344	966	40	4	Pass
0.4386	925	39	4	Pass
0.4429	879	38	4	Pass
0.4472	815	37	4	Pass
0.4514	777	37	4	Pass
0.4557	742	36	4	Pass
0.4600	700	36	5	Pass
0.4642	640	35	5	Pass
0.4685	604	35	5	Pass
0.4728	561	34	6	Pass
0.4770	517	33	6	Pass
0.4813	478	33	6	Pass
0.4856	439	33	7	Pass
0.4898	398	32	8	Pass
0.4941	363	32	8	Pass
0.4984	342	32	9	Pass
0.5026	314	31	9	Pass
0.5069	297	31	10	Pass
0.5112	273	31	11	Pass
0.5154	253	31	12	Pass
0.5197	240	30	12	Pass
0.5240	225	30	13	Pass
0.5282	207	30	14	Pass
0.5325	195	29	14	Pass
0.5368	181	29	16	Pass

Water Quality

Water Quality BMP Flow and Volume for POC #1

On-line facility volume: 0.7209 acre-feet

On-line facility target flow: 0.8804 cfs.

Adjusted for 15 min: 0.8804 cfs.

Off-line facility target flow: 0.505 cfs.

Adjusted for 15 min: 0.505 cfs.

Model Default Modifications

Total of 0 changes have been made.

PERLND Changes

No PERLND changes have been made.

IMPLND Changes

No IMPLND changes have been made.

Appendix
Predeveloped Schematic



Mitigated Schematic

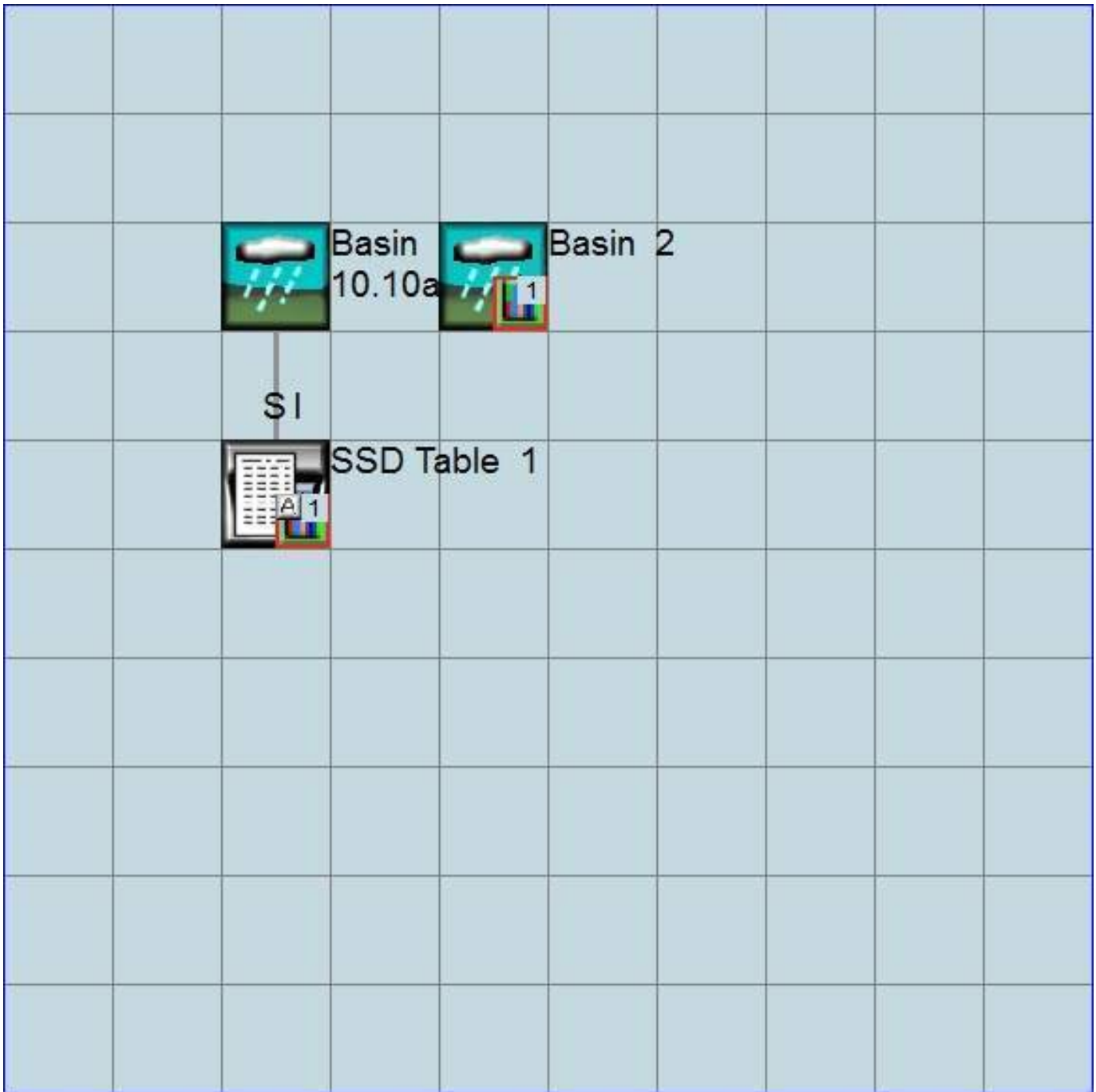

Predeveloped UCI File

RUN

GLOBAL

```
WVHM4 model simulation
START      1901 10 01      END      2059 09 30
RUN INTERP OUTPUT LEVEL   3      0
RESUME     0 RUN          1
UNIT SYSTEM 1
```

END GLOBAL

FILES

```
<File> <Un#> <-----File Name----->***
<-ID->                                     ***
WDM      26      16718FC&WQ.wdm
MESSU    25      Pre16718FC&WQ.MES
          27      Pre16718FC&WQ.L61
          28      Pre16718FC&WQ.L62
          30      POC16718FC&WQ1.dat
```

END FILES

OPN SEQUENCE

```
INGRP          INDELT 00:15
  PERLND        10
  COPY          501
  DISPLY        1
```

END INGRP

END OPN SEQUENCE

DISPLY

DISPLY-INFO1

```
# - #<-----Title----->***TRAN PIVL DIG1 FIL1  PYR DIG2 FIL2 YRND
1   Basin 1          MAX          1   2   30   9
```

END DISPLY-INFO1

END DISPLY

COPY

TIMESERIES

```
# - # NPT NMN ***
1   1   1
501 1   1
```

END TIMESERIES

END COPY

GENER

OPCODE

```
# # OPCODE ***
```

END OPCODE

PARM

```
# # K ***
```

END PARM

END GENER

PERLND

GEN-INFO

```
<PLS ><-----Name----->NBLKS Unit-systems Printer ***
# - # User t-series Engr Metr ***
          in out ***
```

```
10 C, Forest, Flat 1 1 1 1 27 0
```

END GEN-INFO

*** Section PWATER***

ACTIVITY

```
<PLS > ***** Active Sections *****
# - # ATMP SNOW PWAT SED PST PWG PQAL MSTL PEST NITR PHOS TRAC ***
10 0 0 1 0 0 0 0 0 0 0 0 0 0
```

END ACTIVITY

PRINT-INFO

```
<PLS > ***** Print-flags ***** PIVL PYR
# - # ATMP SNOW PWAT SED PST PWG PQAL MSTL PEST NITR PHOS TRAC *****
10 0 0 4 0 0 0 0 0 0 0 0 0 0 1 9
```

END PRINT-INFO

```

PWAT-PARM1
<PLS > PWATER variable monthly parameter value flags ***
# - # CSNO RTOP UZFG VCS VUZ VNN VIFW VIRC VLE INFC HWT ***
10 0 0 0 0 0 0 0 0 0 0 0
END PWAT-PARM1

PWAT-PARM2
<PLS > PWATER input info: Part 2 ***
# - # ***FOREST LZSN INFILT LSUR SLSUR KVARY AGWRC
10 0 4.5 0.08 400 0.05 0.5 0.996
END PWAT-PARM2

PWAT-PARM3
<PLS > PWATER input info: Part 3 ***
# - # ***PETMAX PETMIN INFEXP INFILD DEEPFR BASETP AGWETP
10 0 0 2 2 0 0 0
END PWAT-PARM3

PWAT-PARM4
<PLS > PWATER input info: Part 4 ***
# - # CEPSC UZSN NSUR INTFW IRC LZETP ***
10 0.2 0.5 0.35 6 0.5 0.7
END PWAT-PARM4

PWAT-STATE1
<PLS > *** Initial conditions at start of simulation
ran from 1990 to end of 1992 (pat 1-11-95) RUN 21 ***
# - # *** CEPS SURS UZS IFWS LZS AGWS GWVS
10 0 0 0 0 2.5 1 0
END PWAT-STATE1

END PERLND

IMPLND
GEN-INFO
<PLS ><-----Name-----> Unit-systems Printer ***
# - # User t-series Engl Metr ***
in out ***

END GEN-INFO
*** Section IWATER***

ACTIVITY
<PLS > ***** Active Sections *****
# - # ATMP SNOW IWAT SLD IWG IQAL ***
END ACTIVITY

PRINT-INFO
<ILS > ***** Print-flags ***** PIVL PYR
# - # ATMP SNOW IWAT SLD IWG IQAL *****
END PRINT-INFO

IWAT-PARM1
<PLS > IWATER variable monthly parameter value flags ***
# - # CSNO RTOP VRS VNN RTLI ***
END IWAT-PARM1

IWAT-PARM2
<PLS > IWATER input info: Part 2 ***
# - # *** LSUR SLSUR NSUR RETSC
END IWAT-PARM2

IWAT-PARM3
<PLS > IWATER input info: Part 3 ***
# - # ***PETMAX PETMIN
END IWAT-PARM3

IWAT-STATE1
<PLS > *** Initial conditions at start of simulation
# - # *** RETS SURS
END IWAT-STATE1

```

END IMPLND

SCHEMATIC

<-Source->	<Name> #	<--Area-->	<-factor-->	<-Target->	MBLK	***
Basin	1***				Tbl#	***
PERLND	10	10.85		COPY 501	12	
PERLND	10	10.85		COPY 501	13	

*****Routing*****
END SCHEMATIC

NETWORK

<-Volume->	<-Grp>	<-Member->	<--Mult-->	Tran	<-Target vols>	<-Grp>	<-Member->	***
<Name>	#	<Name> #	#	<-factor-->strg	<Name> #	#	<Name> #	***
COPY	501	OUTPUT	MEAN	1 1 48.4	DISPLY	1	INPUT	TIMSER 1

<-Volume->	<-Grp>	<-Member->	<--Mult-->	Tran	<-Target vols>	<-Grp>	<-Member->	***
<Name>	#	<Name> #	#	<-factor-->strg	<Name> #	#	<Name> #	***

END NETWORK

RCHRES

GEN-INFO

RCHRES	Name	Nexits	Unit	Systems	Printer	***
# - #	<----->	<---->	User	T-series	Engl Metr	LKFG
			in	out		***

END GEN-INFO
*** Section RCHRES***

ACTIVITY

<PLS > ***** Active Sections *****

#	-	#	HYFG	ADFG	CNFG	HTFG	SDFG	GQFG	OXFG	NUFG	PKFG	PHFG	***
#	-	#	HYFG	ADFG	CNFG	HTFG	SDFG	GQFG	OXFG	NUFG	PKFG	PHFG	***

END ACTIVITY

PRINT-INFO

<PLS > ***** Print-flags ***** PIVL PYR

#	-	#	HYDR	ADCA	CONS	HEAT	SED	GQL	OXRX	NUTR	PLNK	PHCB	PIVL	PYR	*****
#	-	#	HYDR	ADCA	CONS	HEAT	SED	GQL	OXRX	NUTR	PLNK	PHCB	PIVL	PYR	*****

END PRINT-INFO

HYDR-PARM1

RCHRES	Flags	for each HYDR	Section	***	ODGTFG	for each	FUNCT	for each
# - #	VC A1 A2 A3	ODFVFG	for each	***	ODGTFG	for each	FUNCT	for each
	FG FG FG FG	possible	exit	***	possible	exit	possible	exit
	* * * *	* * * *	* * *		* * * *	* * *	***	

END HYDR-PARM1

HYDR-PARM2

#	-	#	FTABNO	LEN	DELTH	STCOR	KS	DB50	***
<----->	<----->	<----->	<----->	<----->	<----->	<----->	<----->	<----->	***

END HYDR-PARM2

HYDR-INIT

RCHRES	Initial	conditions	for each HYDR	section	***
# - #	***	VOL	Initial	value of COLIND	Initial
	***	ac-ft	for each	possible exit	for each
					possible exit
<----->	<----->	<----->	<----->	<----->	***

END HYDR-INIT

END RCHRES

SPEC-ACTIONS

END SPEC-ACTIONS

FTABLES

END FTABLES

EXT SOURCES

<-Volume->	<Member>	SsysSgap	<--Mult-->	Tran	<-Target vols>	<-Grp>	<-Member->	***
<Name>	#	<Name> #	tem	strg	<-factor-->strg	<Name> #	#	<Name> #
WDM	2	PREC	ENGL	1	PERLND	1 999	EXTNL	PREC
WDM	2	PREC	ENGL	1	IMPLND	1 999	EXTNL	PREC

```
WDM      1 EVAP      ENGL      1          PERLND    1 999 EXTNL  PETINP
WDM      1 EVAP      ENGL      1          IMPLND    1 999 EXTNL  PETINP
```

END EXT SOURCES

EXT TARGETS

```
<-Volume-> <-Grp> <-Member-><--Mult-->Tran <-Volume-> <Member> Tsys Tgap Amd ***
<Name>      #      <Name> # #<-factor->strg <Name>      # <Name>      tem strg strg***
COPY      501 OUTPUT MEAN    1 1      48.4      WDM      501 FLOW      ENGL      REPL
END EXT TARGETS
```

MASS-LINK

```
<Volume>   <-Grp> <-Member-><--Mult-->   <Target>           <-Grp> <-Member->***
<Name>     #      <Name> # #<-factor->   <Name>           <Name> # #***
  MASS-LINK      12
PERLND      PWATER SURO           0.083333   COPY           INPUT  MEAN
  END MASS-LINK      12
```

```
  MASS-LINK      13
PERLND      PWATER IFWO           0.083333   COPY           INPUT  MEAN
  END MASS-LINK      13
```

END MASS-LINK

END RUN

Mitigated UCI File

RUN

GLOBAL

```
WVHM4 model simulation
START      1901 10 01      END      2059 09 30
RUN INTERP OUTPUT LEVEL   3      0
RESUME     0 RUN         1
UNIT SYSTEM 1
```

END GLOBAL

FILES

```
<File> <Un#> <-----File Name----->***
<-ID->                                     ***
WDM      26      16718FC&WQ.wdm
MESSU    25      Mit16718FC&WQ.MES
          27      Mit16718FC&WQ.L61
          28      Mit16718FC&WQ.L62
          30      POC16718FC&WQ1.dat
```

END FILES

OPN SEQUENCE

```
INGRP          INDELT 00:15
  PERLND        10
  IMPLND         4
  IMPLND        11
  RCHRES         1
  COPY           1
  COPY          501
  COPY          601
  DISPLY         1
```

END INGRP

END OPN SEQUENCE

DISPLY

DISPLY-INF01

```
# - #<-----Title----->***TRAN PIVL DIG1 FIL1 PYR DIG2 FIL2 YRND
1      SSD Table 1          MAX          1      2      30      9
```

END DISPLY-INF01

END DISPLY

COPY

TIMESERIES

```
# - # NPT NMN ***
1      1      1
501    1      1
601    1      1
```

END TIMESERIES

END COPY

GENER

OPCODE

```
#      # OPCODE ***
```

END OPCODE

PARM

```
#      #          K ***
```

END PARM

END GENER

PERLND

GEN-INFO

```
<PLS ><-----Name----->NBLKS Unit-systems Printer ***
# - # User t-series Engl Metr ***
          in out ***
10      C, Forest, Flat      1      1      1      1      27      0
```

END GEN-INFO

*** Section PWATER***

ACTIVITY

```
<PLS > ***** Active Sections *****
# - # ATMP SNOW PWAT SED PST PWG PQAL MSTL PEST NITR PHOS TRAC ***
10      0      0      1      0      0      0      0      0      0      0      0      0
```

END ACTIVITY

```

PRINT-INFO
<PLS > ***** Print-flags ***** PIVL  PYR
# - # ATMP SNOW PWAT  SED  PST  PWG  PQAL MSTL PEST NITR PHOS TRAC  *****
10   0   0   4   0   0   0   0   0   0   0   0   0   0   1   9
END PRINT-INFO

```

```

PWAT-PARM1
<PLS > PWATER variable monthly parameter value flags ***
# - # CSNO RTOP UZFG  VCS  VUZ  VNN VIFW VIRC  VLE INFC  HWT ***
10   0   0   0   0   0   0   0   0   0   0   0   0
END PWAT-PARM1

```

```

PWAT-PARM2
<PLS > PWATER input info: Part 2          ***
# - # ***FOREST  LZSN  INFILT  LRSUR  SLSUR  KVARY  AGWRC
10   0   4.5  0.08  400   0.05  0.5   0.996
END PWAT-PARM2

```

```

PWAT-PARM3
<PLS > PWATER input info: Part 3          ***
# - # ***PETMAX  PETMIN  INFEXP  INFILD  DEEPFR  BASETP  AGWETP
10   0   0   2   2   0   0   0
END PWAT-PARM3

```

```

PWAT-PARM4
<PLS > PWATER input info: Part 4          ***
# - # CEPSC  UZSN  NSUR  INTFW  IRC  LZETP ***
10   0.2  0.5  0.35  6   0.5  0.7
END PWAT-PARM4

```

```

PWAT-STATE1
<PLS > *** Initial conditions at start of simulation
ran from 1990 to end of 1992 (pat 1-11-95) RUN 21 ***
# - # *** CEPS  SURS  UZS  IFWS  LZS  AGWS  GWVS
10   0   0   0   0   2.5  1   0
END PWAT-STATE1

```

END PERLND

IMPLND

```

GEN-INFO
<PLS ><-----Name----->  Unit-systems  Printer ***
# - # User t-series Engl Metr ***
# - # in out ***
4   ROOF TOPS/FLAT  1  1  1  27  0
11  PARKING/FLAT   1  1  1  27  0
END GEN-INFO
*** Section IWATER***

```

```

ACTIVITY
<PLS > ***** Active Sections *****
# - # ATMP SNOW IWAT  SLD  IWG IQAL  ***
4   0   0   1   0   0   0
11  0   0   1   0   0   0
END ACTIVITY

```

```

PRINT-INFO
<ILS > ***** Print-flags ***** PIVL  PYR
# - # ATMP SNOW IWAT  SLD  IWG IQAL  *****
4   0   0   4   0   0   0   1   9
11  0   0   4   0   0   0   1   9
END PRINT-INFO

```

```

IWAT-PARM1
<PLS > IWATER variable monthly parameter value flags ***
# - # CSNO RTOP  VRS  VNN RTLI  ***
4   0   0   0   0   0
11  0   0   0   0   0
END IWAT-PARM1

```

IWAT-PARM2

```

<PLS >          IWATER input info: Part 2          ***
# - # ***  LSUR      SLSUR      NSUR      RETSC
4          400      0.01      0.1      0.1
11         400      0.01      0.1      0.1
END IWAT-PARM2

```

```

IWAT-PARM3
<PLS >          IWATER input info: Part 3          ***
# - # ***PETMAX    PETMIN
4          0        0
11         0        0
END IWAT-PARM3

```

```

IWAT-STATE1
<PLS > *** Initial conditions at start of simulation
# - # ***  RETS      SURS
4          0        0
11         0        0
END IWAT-STATE1

```

END IMPLND

```

SCHEMATIC
<-Source->
<Name> #
Basin 1***
PERLND 10          4.11    RCHRES 1    2
PERLND 10          4.11    RCHRES 1    3
IMPLND 4           2.5     RCHRES 1    5
IMPLND 11          3.49    RCHRES 1    5

```

```

*****Routing*****
PERLND 10          4.11    COPY 1    12
IMPLND 4           2.5     COPY 1    15
IMPLND 11          3.49    COPY 1    15
PERLND 10          4.11    COPY 1    13
RCHRES 1           1       COPY 501  16
END SCHEMATIC

```

```

NETWORK
<-Volume-> <-Grp> <-Member-><--Mult-->Tran <-Target vols> <-Grp> <-Member-> ***
<Name> # <Name> # #<-factor-->strg <Name> # # <Name> # # ***
COPY 501 OUTPUT MEAN 1 1 48.4 DISPLY 1 INPUT TIMSER 1

```

```

<-Volume-> <-Grp> <-Member-><--Mult-->Tran <-Target vols> <-Grp> <-Member-> ***
<Name> # <Name> # #<-factor-->strg <Name> # # <Name> # # ***
END NETWORK

```

```

RCHRES
GEN-INFO
RCHRES          Name          Nexits  Unit Systems  Printer          ***
# - #<-----><----> User T-series Engl Metr LKFG          ***
1          SSD Table 1          1      1      1      1      28      0      1          ***
END GEN-INFO
*** Section RCHRES***

```

```

ACTIVITY
<PLS > ***** Active Sections *****
# - # HYFG ADFG CNFG HTFG SDFG GQFG OXFG NUGF PKFG PHFG ***
1          1      0      0      0      0      0      0      0      0
END ACTIVITY

```

```

PRINT-INFO
<PLS > ***** Print-flags ***** PIVL  PYR
# - # HYDR ADCA CONS HEAT  SED  GQL  OXRX NUTR PLNK PHCB PIVL  PYR  *****
1          4      0      0      0      0      0      0      0      0      0      1      9
END PRINT-INFO

```

```

HYDR-PARM1
RCHRES  Flags for each HYDR Section ***
# - # VC A1 A2 A3 ODFVFG for each *** ODGTFG for each FUNCT for each
      FG FG FG FG possible exit *** possible exit possible exit
      * * * * * * * * * * * * * * * * * * * * * * * * * * * * * * * * * *
1      0 1 0 0 4 0 0 0 0 0 0 0 0 0 0 0 2 2 2 2 2
END HYDR-PARM1

```

```

HYDR-PARM2
# - # FTABNO LEN DELTH STCOR KS DB50 ***
<---><-----><-----><-----><-----><-----><-----> ***
1      1 0.01 0.0 0.0 0.5 0.0 ***
END HYDR-PARM2

```

```

HYDR-INIT
RCHRES  Initial conditions for each HYDR section ***
# - # *** VOL Initial value of COLIND Initial value of OUTDGT
      *** ac-ft for each possible exit for each possible exit
<-----><-----><-----><-----><-----><-----><-----><-----><----->
1      0 4.0 0.0 0.0 0.0 0.0 0.0 0.0 0.0 0.0 0.0 0.0
END HYDR-INIT
END RCHRES

```

```

SPEC-ACTIONS
END SPEC-ACTIONS
FTABLES

```

```

FTABLE 1
61 4
Depth Area Volume Outflowl Velocity Travel Time***
(ft) (acres) (acre-ft) (cfs) (ft/sec) (Minutes)***
0.00000 0.432070 0.000000 0.000000
0.10000 0.438126 0.043509 0.019308
0.20000 0.444182 0.087625 0.027306
0.30000 0.450238 0.132346 0.033443
0.40000 0.456294 0.177673 0.038616
0.50000 0.462350 0.223605 0.043174
0.60000 0.468406 0.270143 0.047295
0.70000 0.474462 0.317286 0.051085
0.80000 0.480518 0.365035 0.054612
0.90000 0.486574 0.413390 0.057925
1.00000 0.492630 0.462350 0.061058
1.10000 0.498824 0.511923 0.064038
1.20000 0.505018 0.562115 0.066885
1.30000 0.511212 0.612927 0.069617
1.40000 0.517405 0.664358 0.072245
1.50000 0.523599 0.716408 0.074780
1.60000 0.529793 0.769078 0.077233
1.70000 0.535987 0.822367 0.079610
1.80000 0.542180 0.876275 0.081918
1.90000 0.548374 0.930803 0.084162
2.00000 0.554568 0.985950 0.086349
2.10000 0.560936 1.041725 0.088481
2.20000 0.567304 1.098137 0.090563
2.30000 0.573673 1.155186 0.092599
2.40000 0.580041 1.212872 0.094590
2.50000 0.586409 1.271194 0.096541
2.60000 0.592777 1.330154 0.098453
2.70000 0.599146 1.389750 0.100328
2.80000 0.605514 1.449983 0.102169
2.90000 0.611882 1.510853 0.103978
3.00000 0.618250 1.572360 0.105755
3.10000 0.624759 1.634510 0.107503
3.20000 0.631267 1.697311 0.109224
3.30000 0.637775 1.760763 0.110917
3.40000 0.644283 1.824866 0.112585
3.50000 0.650792 1.889620 0.114229
3.60000 0.657300 1.955025 0.115906
3.70000 0.663808 2.021080 0.117503
3.80000 0.670316 2.087787 0.119030
3.90000 0.676825 2.155144 0.119868

```

4.000000	0.683333	2.223152	0.211120
4.100000	0.690041	2.291820	0.237979
4.200000	0.696749	2.361160	0.254785
4.300000	0.703457	2.431170	0.269395
4.400000	0.710165	2.501851	0.282669
4.500000	0.716873	2.573203	0.294984
4.600000	0.723581	2.645226	0.306553
4.700000	0.730289	2.717919	0.317518
4.800000	0.736997	2.791284	0.327976
4.900000	0.743705	2.865319	0.337999
5.000000	0.750413	2.940025	0.347643
5.100000	0.757178	3.015404	0.859131
5.200000	0.763944	3.091461	1.770429
5.300000	0.770709	3.168193	2.875970
5.400000	0.777474	3.245602	4.015409
5.500000	0.784240	3.323688	5.030577
5.600000	0.791005	3.402450	5.800777
5.700000	0.797770	3.481889	6.299973
5.800000	0.804536	3.562005	6.753655
5.900000	0.811301	3.642796	7.145695
6.000000	0.818067	3.724265	7.516751

END FTABLE 1

END FTABLES

EXT SOURCES

<-Volume->	<Member>	SsysSgap	<--Mult-->	Tran	<-Target vols>	<-Grp>	<-Member->	***	
<Name>	#	<Name>	#	tem strg	<-factor->	strg	<Name>	# #	***
WDM	2	PREC		ENGL	1		PERLND	1 999	EXTNL PREC
WDM	2	PREC		ENGL	1		IMPLND	1 999	EXTNL PREC
WDM	1	EVAP		ENGL	1		PERLND	1 999	EXTNL PETINP
WDM	1	EVAP		ENGL	1		IMPLND	1 999	EXTNL PETINP

END EXT SOURCES

EXT TARGETS

<-Volume->	<-Grp>	<-Member->	<--Mult-->	Tran	<-Volume->	<Member>	Tsys	Tgap	Amd	***	
<Name>	#	<Name>	#	<-factor->	strg	<Name>	#	<Name>	tem strg	strg	***
COPY	1	OUTPUT	MEAN	1	1	48.4	WDM	701	FLOW	ENGL	REPL
COPY	501	OUTPUT	MEAN	1	1	48.4	WDM	801	FLOW	ENGL	REPL
COPY	601	OUTPUT	MEAN	1	1	48.4	WDM	901	FLOW	ENGL	REPL
RCHRES	1	HYDR	RO	1	1	1	WDM	1006	FLOW	ENGL	REPL
RCHRES	1	HYDR	STAGE	1	1	1	WDM	1007	STAG	ENGL	REPL

END EXT TARGETS

MASS-LINK

<Volume>	<-Grp>	<-Member->	<--Mult-->	<Target>	<-Grp>	<-Member->	***		
<Name>		<Name>	# #	<-factor->	<Name>		<Name>	# #	***
MASS-LINK			2						
PERLND	PWATER	SURO		0.083333	RCHRES		INFLOW	IVOL	
END MASS-LINK			2						
MASS-LINK			3						
PERLND	PWATER	IFWO		0.083333	RCHRES		INFLOW	IVOL	
END MASS-LINK			3						
MASS-LINK			5						
IMPLND	IWATER	SURO		0.083333	RCHRES		INFLOW	IVOL	
END MASS-LINK			5						
MASS-LINK			12						
PERLND	PWATER	SURO		0.083333	COPY		INPUT	MEAN	
END MASS-LINK			12						
MASS-LINK			13						
PERLND	PWATER	IFWO		0.083333	COPY		INPUT	MEAN	
END MASS-LINK			13						
MASS-LINK			15						
IMPLND	IWATER	SURO		0.083333	COPY		INPUT	MEAN	
END MASS-LINK			15						

MASS-LINK 16
RCHRES ROFLOW COPY INPUT MEAN
END MASS-LINK 16

END MASS-LINK

END RUN

Disclaimer

Legal Notice

This program and accompanying documentation are provided 'as-is' without warranty of any kind. The entire risk regarding the performance and results of this program is assumed by End User. Clear Creek Solutions Inc. and the governmental licensee or sublicensees disclaim all warranties, either expressed or implied, including but not limited to implied warranties of program and accompanying documentation. In no event shall Clear Creek Solutions Inc. be liable for any damages whatsoever (including without limitation to damages for loss of business profits, loss of business information, business interruption, and the like) arising out of the use of, or inability to use this program even if Clear Creek Solutions Inc. or their authorized representatives have been advised of the possibility of such damages. Software Copyright © by : Clear Creek Solutions, Inc. 2005-2017; All Rights Reserved.

Clear Creek Solutions, Inc.
6200 Capitol Blvd. Ste F
Olympia, WA. 98501
Toll Free 1(866)943-0304
Local (360)943-0304

www.clearcreeksolutions.com

STORMFILTER CALCULATIONS

WWHM2012

PROJECT REPORT

16718 - Wesley Homes Puyallup
Stormfilter Sizing
5/26/2017

General Model Information

Project Name: 16718-WQ2
Site Name: Wesley Homes Puyallup
Site Address: 707 39th Ave. SE
City: Puyallup
Report Date: 5/26/2017
Gage:
Data Start: 10/01/1901
Data End: 09/30/2059
Timestep: 15 Minute
Precip Scale: 0.00 (adjusted)
Version Date: 2016/02/25
Version: 4.2.12

POC Thresholds

Low Flow Threshold for POC1:	50 Percent of the 2 Year
High Flow Threshold for POC1:	50 Year

Landuse Basin Data

Predeveloped Land Use

Basin 1

Bypass:	No
GroundWater:	No
Pervious Land Use	acre
Pervious Total	0
Impervious Land Use	acre
PARKING FLAT	0.105
Impervious Total	0.105
Basin Total	0.105

Element Flows To:		
Surface	Interflow	Groundwater

Mitigated Land Use

Basin 1

Bypass:	No
GroundWater:	No
Pervious Land Use	acre
Pervious Total	0
Impervious Land Use	acre
PARKING FLAT	0.105
Impervious Total	0.105
Basin Total	0.105

Element Flows To:		
Surface	Interflow	Groundwater

Analysis Results

POC 1

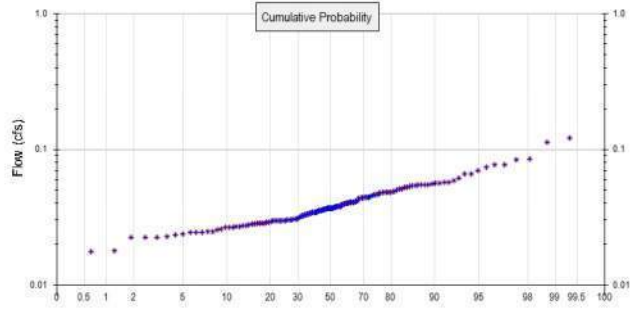
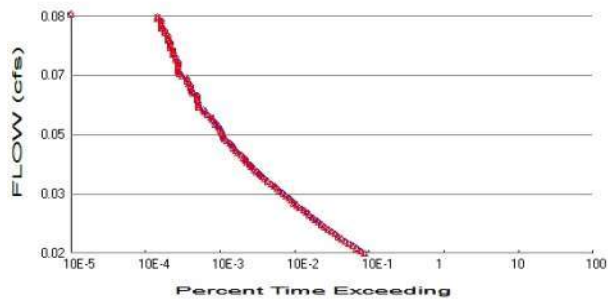

+ Predeveloped x Mitigated

Predeveloped Landuse Totals for POC #1

Total Pervious Area: 0
 Total Impervious Area: 0.105

Mitigated Landuse Totals for POC #1

Total Pervious Area: 0
 Total Impervious Area: 0.105

Flow Frequency Method: Log Pearson Type III 17B

Flow Frequency Return Periods for Predeveloped. POC #1

Return Period	Flow(cfs)
2 year	0.036797
5 year	0.049394
10 year	0.058549
25 year	0.07108
50 year	0.081136
100 year	0.091831

Flow Frequency Return Periods for Mitigated. POC #1

Return Period	Flow(cfs)
2 year	0.036797
5 year	0.049394
10 year	0.058549
25 year	0.07108
50 year	0.081136
100 year	0.091831

Annual Peaks

Annual Peaks for Predeveloped and Mitigated. POC #1

Year	Predeveloped	Mitigated
1902	0.044	0.044
1903	0.048	0.048
1904	0.055	0.055
1905	0.024	0.024
1906	0.027	0.027
1907	0.037	0.037
1908	0.030	0.030
1909	0.037	0.037
1910	0.035	0.035
1911	0.040	0.040

Water Quality

Water Quality BMP Flow and Volume for POC #1

On-line facility volume: 0.0112 acre-feet

On-line facility target flow: 0.0155 cfs.

Adjusted for 15 min: 0.0155 cfs.

Off-line facility target flow: 0.0089 cfs.

Adjusted for 15 min: 0.0089 cfs.

Appendix
Predeveloped Schematic



Mitigated Schematic



Disclaimer

Legal Notice

This program and accompanying documentation are provided 'as-is' without warranty of any kind. The entire risk regarding the performance and results of this program is assumed by End User. Clear Creek Solutions Inc. and the governmental licensee or sublicensees disclaim all warranties, either expressed or implied, including but not limited to implied warranties of program and accompanying documentation. In no event shall Clear Creek Solutions Inc. be liable for any damages whatsoever (including without limitation to damages for loss of business profits, loss of business information, business interruption, and the like) arising out of the use of, or inability to use this program even if Clear Creek Solutions Inc. or their authorized representatives have been advised of the possibility of such damages. Software Copyright © by : Clear Creek Solutions, Inc. 2005-2017; All Rights Reserved.

Clear Creek Solutions, Inc.
6200 Capitol Blvd. Ste F
Olympia, WA. 98501
Toll Free 1(866)943-0304
Local (360)943-0304

www.clearcreeksolutions.com

CONVEYANCE BASIN MAP

CONVEYANCE BASIN MAP FOR WESLEY HOMES PUYALLUP

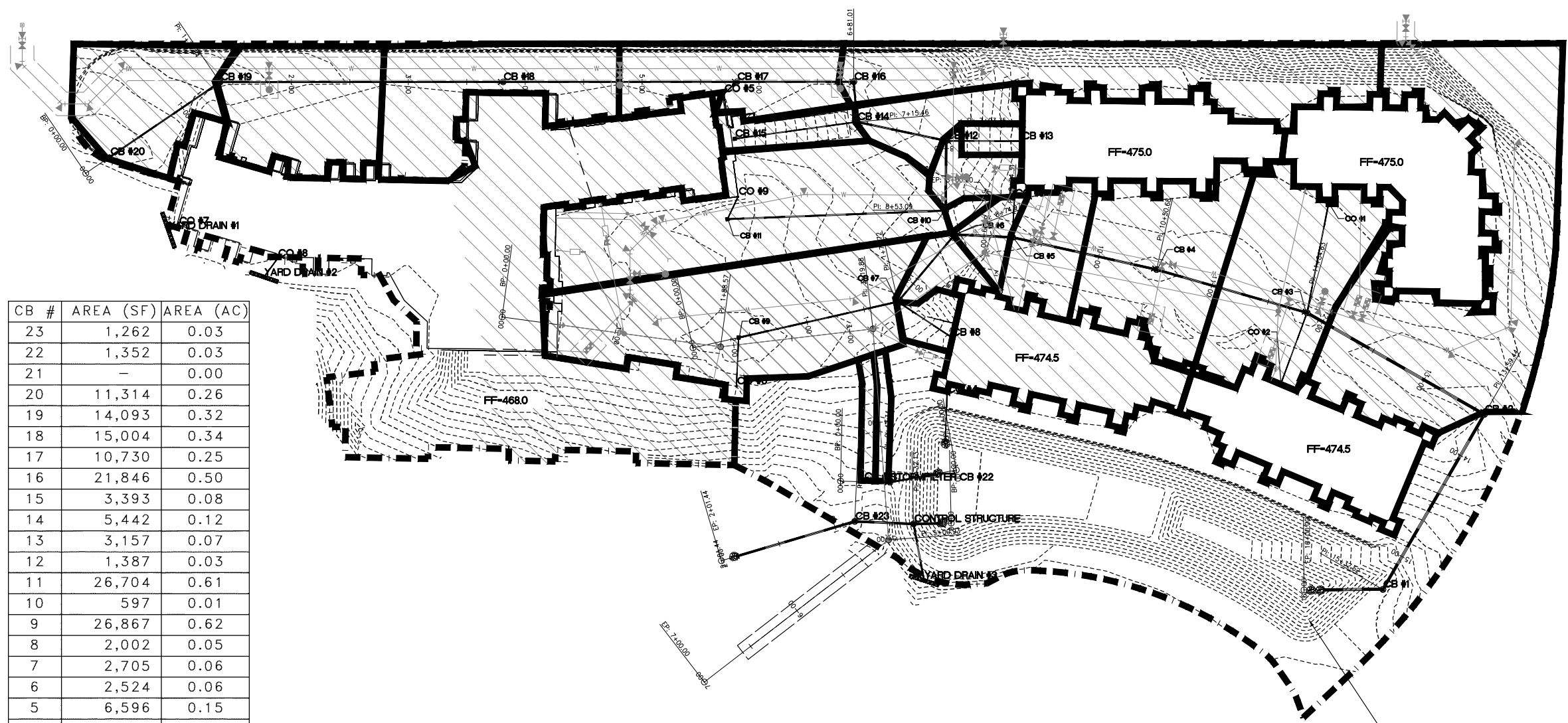
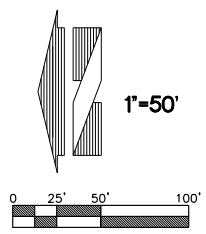

CB #	AREA (SF)	AREA (AC)
23	1,262	0.03
22	1,352	0.03
21	-	0.00
20	11,314	0.26
19	14,093	0.32
18	15,004	0.34
17	10,730	0.25
16	21,846	0.50
15	3,393	0.08
14	5,442	0.12
13	3,157	0.07
12	1,387	0.03
11	26,704	0.61
10	597	0.01
9	26,867	0.62
8	2,002	0.05
7	2,705	0.06
6	2,524	0.06
5	6,596	0.15
4	16,624	0.38
3	18,673	0.43
2	38,609	0.89
1	-	-
RD 1	19,201	0.44
RD 2	14,801	0.34
RD 3	15,429	0.35
RD 4	14,870	0.34
RD 5	8,155	0.19
RD 6	27,251	0.63
RD 7	19,495	0.45
RD 8	13,463	0.31
RD 9	8,154	0.19

PROPOSED WET/DETENTION POND
 TOP POND = 459.0
 MAX W.S. = 457.0
 STATIC W.S. = 452.0
 BOTTOM OF POND = 447.0
 DETENTION VOLUME PROVIDED = 149,873± CU. FT.

Revision					
No.	Date	By	Ckd.	Appr.	
Title:					
BASIN MAP					
WESLEY HOMES					
PUYALLUP, WA					

For: **WESLEY HOMES**
PUYALLUP, WA

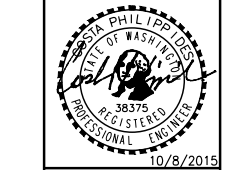

Scale:	Horizontal	Vertical
	1"=60'	N/A
Designed	CP	
Drawn	CK	
Checked	CP	
Approved	CP	
Date	5/25/14	

18215 72ND AVENUE SOUTH
 KENT, WA 98032
 (425)251-6222 FAX
 (425)251-8762
 CIVIL ENGINEERING, LAND PLANNING,
 SURVEYING, ENVIRONMENTAL SERVICES



Job Number	16718
Sheet	1 of 1

CONVEYANCE CALCULATIONS

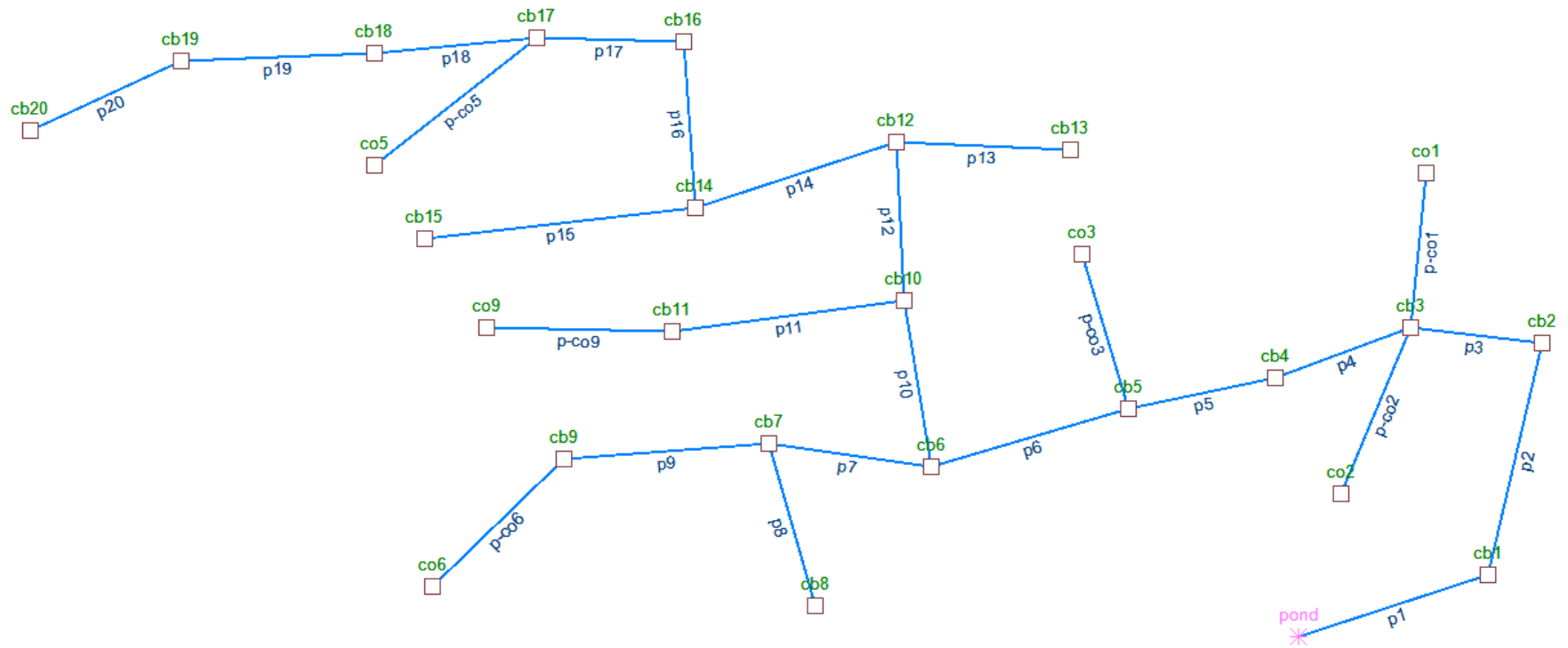

16718-Wesley Homes Puyallup
Stormshed3G Conveyance Calculations

Structure and Pipe Labels

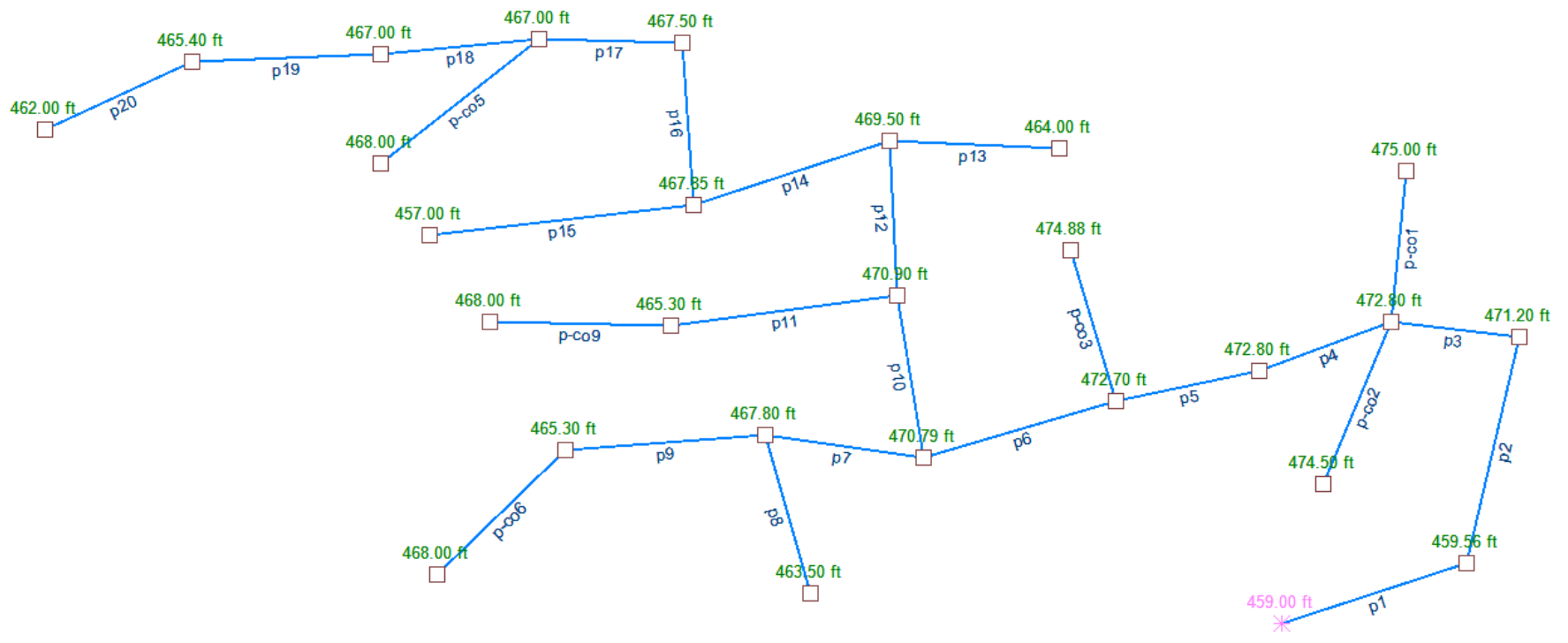

Structure Rim Elevations

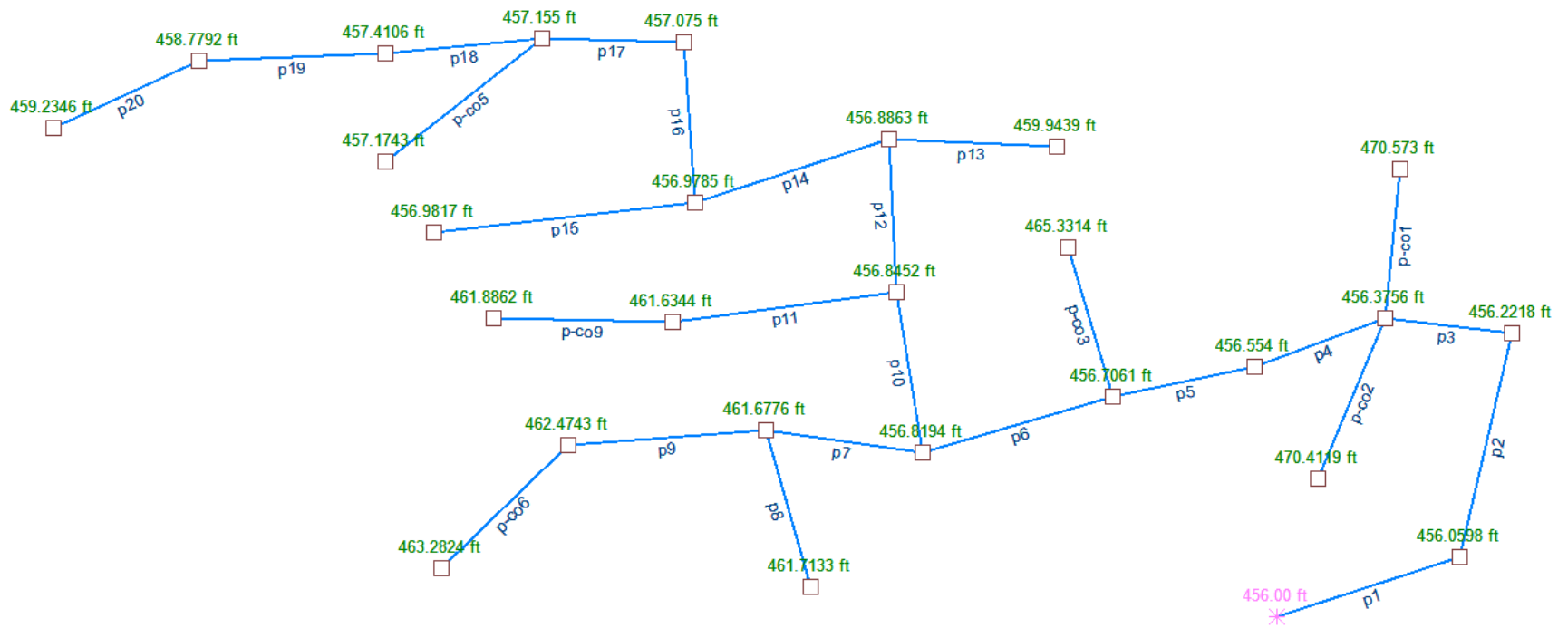

Hydraulic Grade Line Elevations

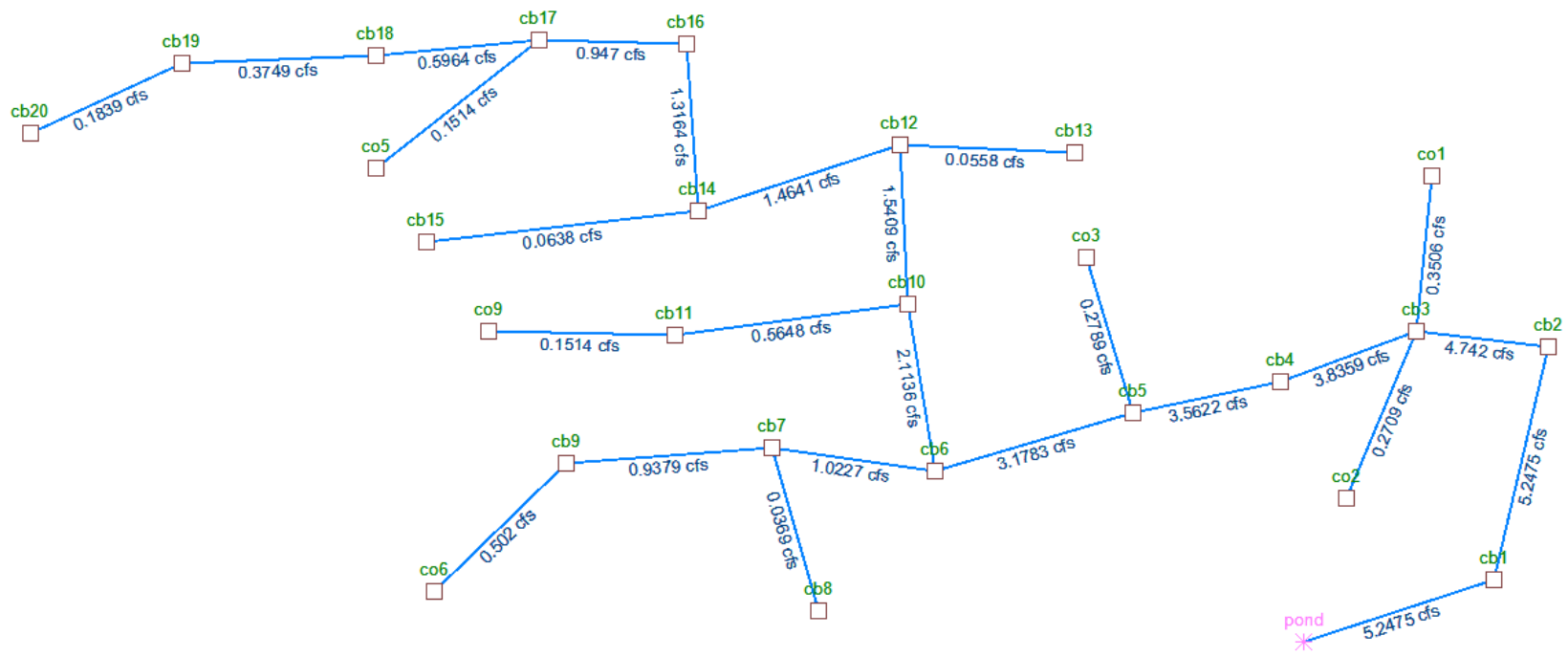

Flowrates

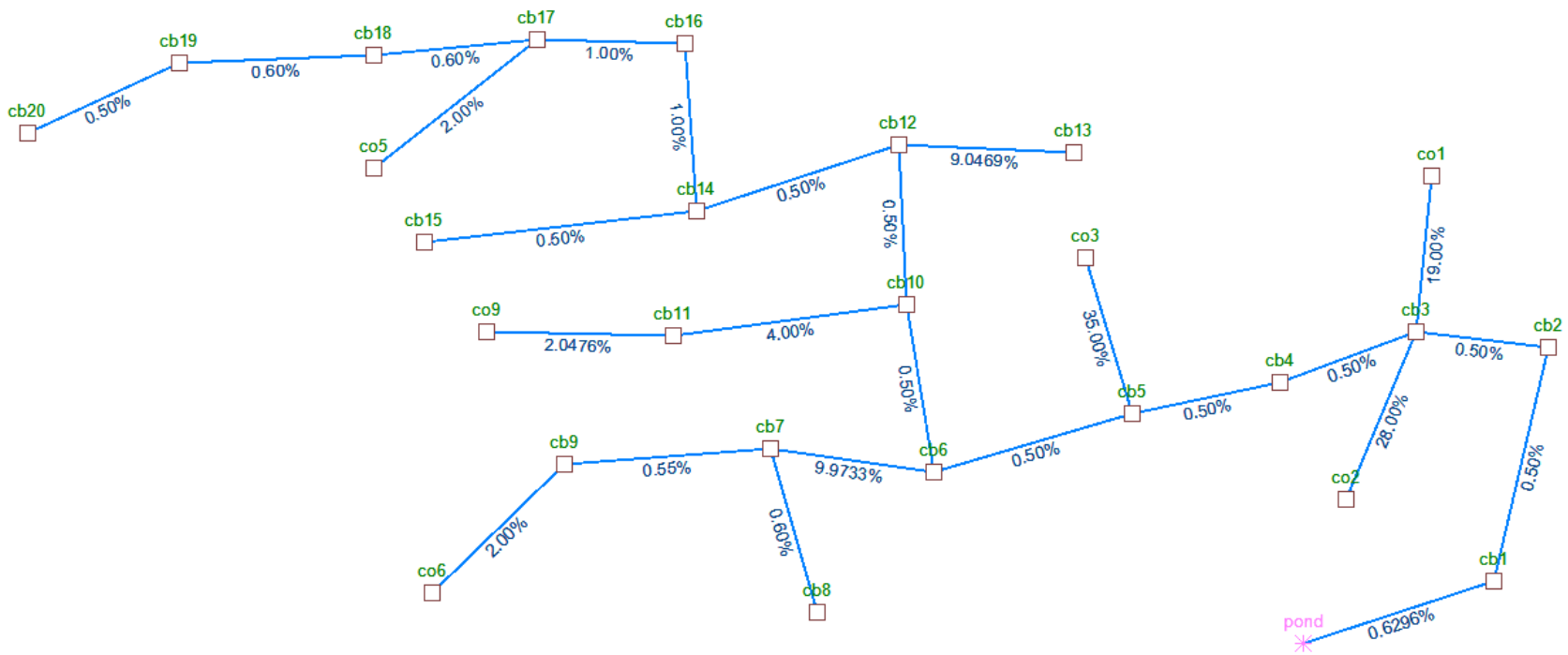

Pipe Slopes

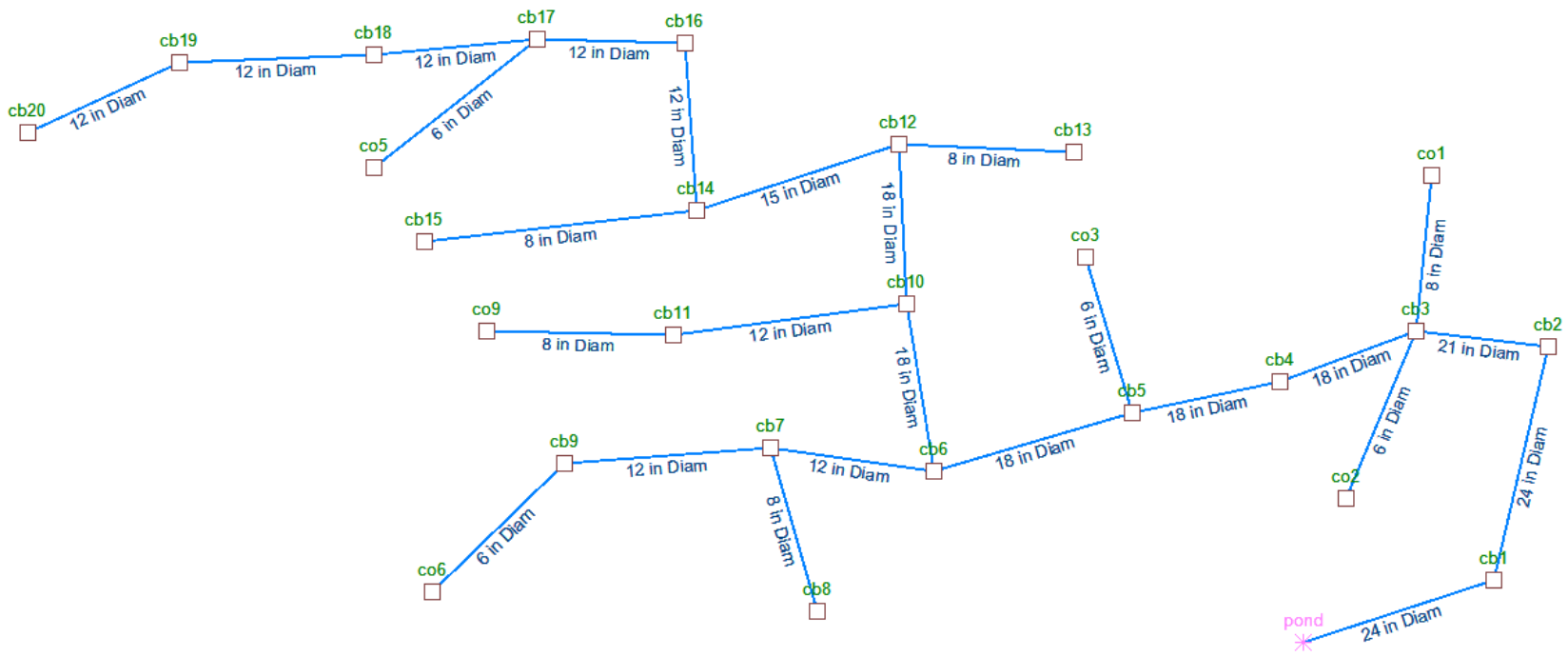

Pipe Diameters

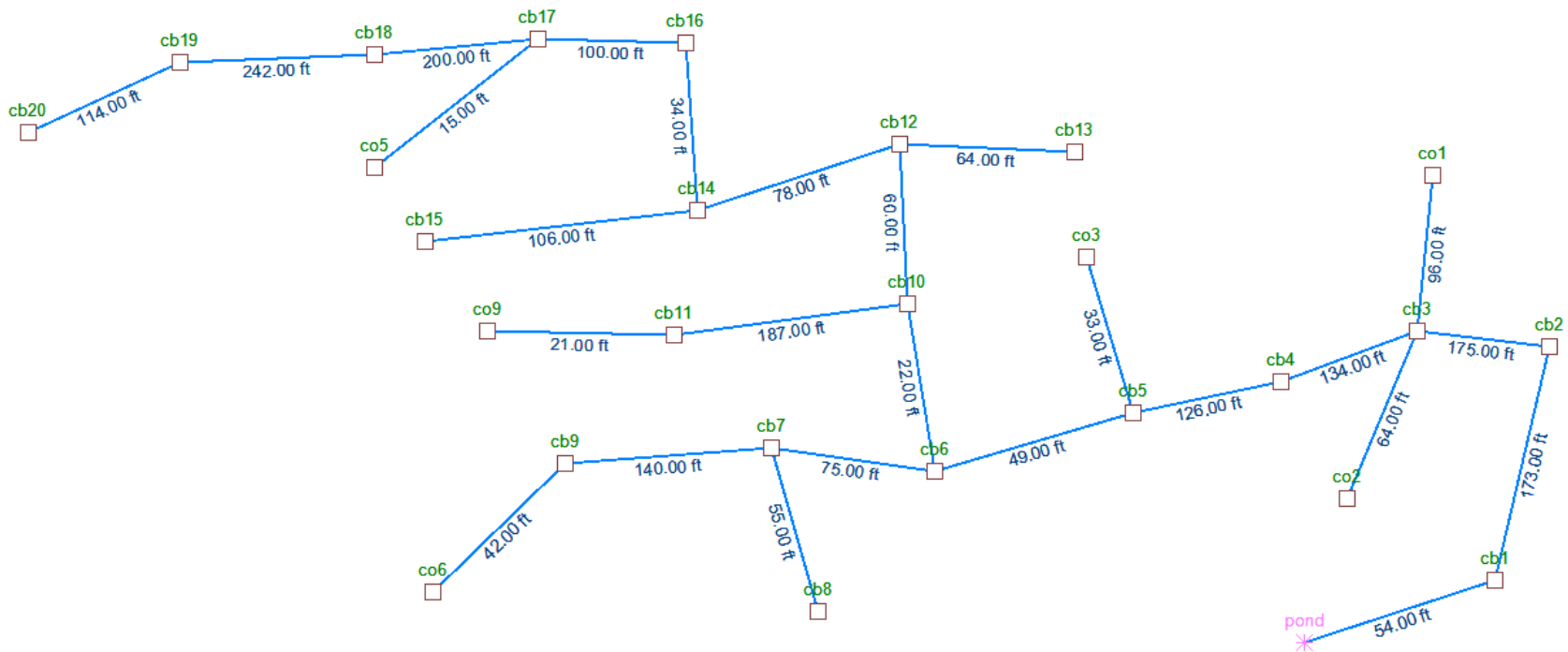

Pipe Lengths

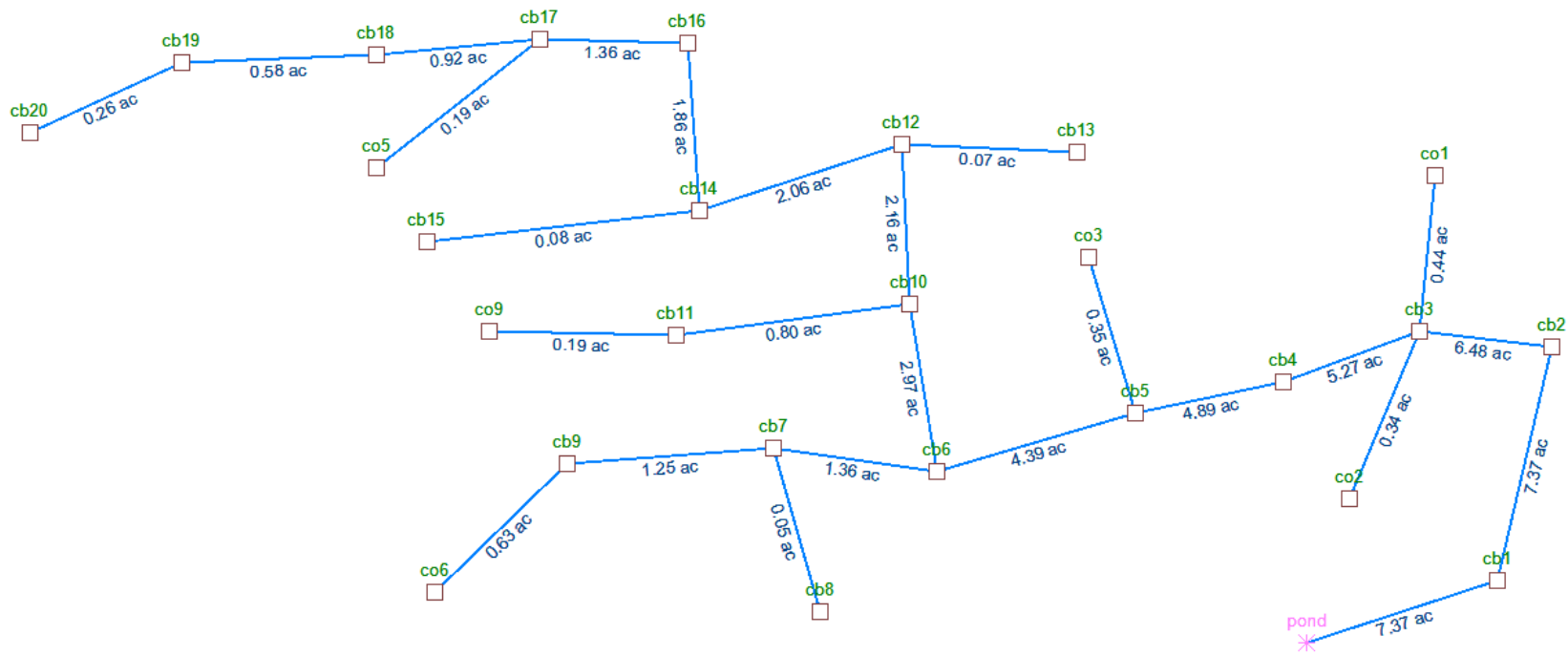

Contributing Areas

Appended on: Friday, May 12, 2017 4:43:03 PM

**ROUTEHYD [] THRU [16718pipe] USING [25 year] AND [TYPE1A.RAC] NOTZERO
RELATIVE SCS/SBUH**

Gravity Analysis using 24 hr duration storm

Reach ID	Area (ac)	Flow (cfs)	Full Q (cfs)	Full ratio	nDepth (ft)	Depth ratio	Size	nVel (ft/s)	fVel (ft/s)	Infil Vol (cf)	CBasin / Hyd
p-co2	0.34	0.2709	3.2252	0.084	0.0979	0.1957	6 in Diam	9.9975	16.4257	0.00	co2
p-co1	0.44	0.3506	5.7201	0.0613	0.1119	0.1679	8 in Diam	9.0777	16.3902	0.00	co1
p-co3	0.35	0.2789	3.6059	0.0773	0.0939	0.1878	6 in Diam	10.9178	18.3645	0.00	co3
p-co5	0.19	0.1514	0.862	0.1757	0.1416	0.2833	6 in Diam	3.31	4.39	0.00	co5
p20	0.26	0.1839	2.7366	0.0672	0.1756	0.1756	12 in Diam	1.9823	3.4843	0.00	cb20
p19	0.58	0.3749	2.9978	0.1251	0.2388	0.2388	12 in Diam	2.6049	3.8169	0.00	cb19
p18	0.92	0.5964	2.9978	0.1989	0.3025	0.3025	12 in Diam	2.9748	3.8169	0.00	cb18
p17	1.36	0.947	3.8701	0.2447	0.3367	0.3367	12 in Diam	4.0762	4.9276	0.00	cb17
p16	1.86	1.3164	3.8701	0.3401	0.402	0.402	12 in Diam	4.4568	4.9276	0.00	cb16
p15	0.08	0.0638	0.9279	0.0687	0.1184	0.1776	8 in Diam	1.522	2.6588	0.00	cb15
p14	2.06	1.4641	4.9617	0.2951	0.4654	0.3723	15 in Diam	3.517	4.0432	0.00	cb14
p13	0.07	0.0558	3.9471	0.0141	0.0556	0.0834	8 in Diam	4.0129	11.3099	0.00	cb13
p12	2.16	1.5409	8.0683	0.191	0.4443	0.2962	18 in Diam	3.5172	4.5657	0.00	cb12
p-co9	0.19	0.1514	2.0485	0.0739	0.1225	0.1838	8 in Diam	3.4384	5.8697	0.00	co9
p11	0.80	0.5648	7.7402	0.073	0.1827	0.1827	12 in Diam	5.7481	9.8551	0.00	cb11
p10	2.97	2.1136	8.0683	0.262	0.5238	0.3492	18 in Diam	3.8464	4.5657	0.00	cb10
p-co6	0.63	0.502	0.862	0.5824	0.2741	0.5482	6 in Diam	4.5556	4.39	0.00	co6
p9	1.25	0.9379	2.8701	0.3268	0.3898	0.3898	12 in Diam	3.3098	3.6544	0.00	cb9
p8	0.05	0.0369	1.0165	0.0363	0.0868	0.1301	8 in Diam	1.3832	2.9126	0.00	cb8

p7	1.36	1.0227	12.222	0.0837	0.1953	0.1953	12 in Diam	9.4615	15.5615	0.00	cb7
p6	4.39	3.1783	8.0683	0.3939	0.6547	0.4365	18 in Diam	4.2888	4.5657	0.00	cb6
p5	4.89	3.5622	8.0683	0.4415	0.698	0.4653	18 in Diam	4.422	4.5657	0.00	cb5
p4	5.27	3.8359	8.0683	0.4754	0.7284	0.4856	18 in Diam	4.5062	4.5657	0.00	cb4
p3	6.48	4.742	12.1705	0.3896	0.7591	0.4338	21 in Diam	4.7402	5.0599	0.00	cb3
p2	7.37	5.2475	17.3761	0.302	0.754	0.377	24 in Diam	4.8415	5.531	0.00	cb2
p1	7.37	5.2475	19.4985	0.2691	0.7086	0.3543	24 in Diam	5.2672	6.2066	0.00	

HGL Analysis

From Node	To Node	HG El (ft)	App (ft)	Bend (ft)	Junct Loss (ft)	Adjusted HG El (ft)	Max El (ft)
							456.00
cb1	pond	456.0766	0.0433	0.0264	-----	456.0597	459.5600
cb2	cb1	456.1906	0.0604	0.0916	-----	456.2218	471.2000
cb3	cb2	456.4270	0.0732	0.0125	0.0092	456.3756	472.8000
co2	cb3	470.4119	-----	-----	-----	470.4119	474.5000
co1	cb3	470.5730	-----	-----	-----	470.5730	475.0000
cb4	cb3	456.6148	0.0631	0.0023	-----	456.5540	472.8000
cb5	cb4	456.7525	0.0502	0.0003	0.0036	456.7061	472.7000
co3	cb5	465.3314	-----	-----	-----	465.3314	474.8800
cb6	cb5	456.8044	0.0222	0.0300	0.0072	456.8194	470.7900
cb10	cb6	456.8536	0.0118	0.0004	0.0031	456.8452	470.9000
cb12	cb10	456.8704	0.0221	0.0374	0.0007	456.8863	469.5000
cb14	cb12	456.9468	0.0436	0.0736	0.0017	456.9786	467.8500
cb16	cb14	457.0702	0.0226	0.0274	-----	457.0750	467.5000
cb17	cb16	457.1620	0.0090	0.0003	0.0017	457.1550	467.0000
co5	cb17	457.1753	-----	-----	-----	457.1753	468.0000
cb18	cb17	457.4091	-----	0.0014	-----	457.4106	467.0000
cb19	cb18	458.7713	-----	0.0079	-----	458.7792	465.4000
cb20	cb19	459.2346	-----	-----	-----	459.2346	462.0000
cb15	cb14	456.9817	-----	-----	-----	456.9817	457.0000
cb13	cb12	459.9439	-----	-----	-----	459.9439	464.0000
cb11	cb10	461.6292	-----	0.0052	-----	461.6344	465.3000
co9	cb11	461.8862	-----	-----	-----	461.8862	468.3000
cb7	cb6	461.6590	-----	0.0131	0.0056	461.6777	467.8000
cb9	cb7	462.4469	-----	0.0274	-----	462.4743	465.3000
co6	cb9	463.2824	-----	-----	-----	463.2824	468.0000

cb8	cb7	461.7133	-----	-----	-----	461.7133	463.5000
-----	-----	----------	-------	-------	-------	----------	----------

Conduit Notes

Reach	HW Depth (ft)	HW/D ratio	Q (cfs)	TW Depth (ft)	Dc (ft)	Dn (ft)	Comment
p1	6.0766	3.0383	5.25	6.0000	0.8080	0.7086	Outlet Control
p2	5.8506	2.9253	5.25	5.7197	0.8080	0.7540	Outlet Control
p3	5.2220	2.9840	4.74	5.0168	0.7979	0.7591	Outlet Control
p-co2	0.3119	0.6238	0.27	4.1956	0.2626	0.0979	SuperCrit flow, Inlet end controls
p-co1	0.3230	0.4846	0.35	4.3656	0.2751	0.1119	SuperCrit flow, Inlet end controls
p4	4.5348	3.0232	3.84	4.2956	0.7490	0.7284	Outlet Control
p5	4.0025	2.6683	3.56	3.8040	0.7205	0.6980	Outlet Control
p-co3	0.3014	0.6028	0.28	3.2261	0.2666	0.0939	SuperCrit flow, Inlet end controls
p6	3.4244	2.2829	3.18	3.3261	0.6787	0.6547	Outlet Control
p10	3.2236	2.1491	2.11	3.1894	0.5488	0.5238	Outlet Control
p12	3.1304	2.0869	1.54	3.1052	0.4660	0.4443	Outlet Control
p14	2.9068	2.3254	1.46	2.8463	0.4790	0.4654	Outlet Control
p16	2.6402	2.6402	1.32	2.5486	0.4849	0.4020	Outlet Control
p17	2.3920	2.3920	0.95	2.3050	0.4083	0.3367	Outlet Control
p-co5	1.4053	2.8106	0.15	1.3850	0.1938	0.1416	Outlet Control
p18	0.4391	0.4391	0.60	1.3850	0.3211	0.3025	SuperCrit flow, Inlet end controls
p19	0.3413	0.3413	0.37	0.4406	0.2529	0.2388	SuperCrit flow, Inlet end controls
p20	0.2346	0.2346	0.18	0.3492	0.1757	0.1756	SuperCrit flow, Inlet end controls
p15	2.5517	3.8279	0.06	2.5486	0.1144	0.1184	Outlet Control
p13	0.1139	0.1709	0.06	2.8463	0.1068	0.0556	SuperCrit flow, Inlet end controls
p11	0.4092	0.4092	0.56	3.1052	0.3123	0.1827	SuperCrit flow, Inlet end controls
p-co9	0.2362	0.3543	0.15	0.4144	0.1781	0.1225	SuperCrit flow, Inlet end controls
p7	0.5490	0.5490	1.02	3.1894	0.4250	0.1953	SuperCrit flow, Inlet end controls
p9	0.5669	0.5669	0.94	0.5677	0.4063	0.3898	SuperCrit flow, Inlet end controls
p-co6	0.5724	1.1448	0.50	0.6043	0.3615	0.2741	SuperCrit flow, Inlet end controls
p8	0.2733	0.4100	0.04	0.5677	0.0867	0.0868	Outlet Control M1 Backwater

Subcritical, M-1 Profile

Subcritical flow starts at downstream end and progresses upstream until normal depth is reached.

y ft	A sf	R	V ft	Eft	dEft	Sf ft	Savg ft	So-Sf ft	dx ft	Station ft	Elev ft
0.5677	0.3167	0.2021	0.1166	0.567868	0.00	0.000007	0.00	0.00	0.00	55.00	461.6777
0.5484	0.3072	0.2028	0.1202	0.548645	0.019223	0.000008	0.000008	0.005992	3.207924	51.7921	461.6777
0.5292	0.2971	0.2027	0.1243	0.529424	0.019221	0.000008	0.000008	0.005992	3.207804	48.5843	461.6777
0.5099	0.2865	0.2018	0.1289	0.510206	0.019218	0.000009	0.000009	0.005991	3.207696	45.3766	461.6777
0.4907	0.2754	0.2003	0.1341	0.490991	0.019215	0.00001	0.00001	0.00599	3.207594	42.169	461.6777
0.4715	0.2639	0.1981	0.14	0.47178	0.019211	0.000011	0.00001	0.00599	3.207494	38.9615	461.6777
0.4522	0.2521	0.1953	0.1465	0.452573	0.019207	0.000012	0.000012	0.005988	3.207389	35.7541	461.6777
0.433	0.24	0.192	0.1539	0.433371	0.019202	0.000014	0.000013	0.005987	3.207275	32.5468	461.6777
0.4138	0.2276	0.1882	0.1623	0.414176	0.019195	0.000016	0.000015	0.005985	3.207144	29.3397	461.6777
0.3945	0.2151	0.1838	0.1717	0.394989	0.019187	0.000018	0.000017	0.005983	3.206989	26.1327	461.6777
0.3753	0.2024	0.1789	0.1825	0.375812	0.019177	0.000021	0.00002	0.00598	3.2068	22.9259	461.6777
0.3561	0.1897	0.1736	0.1947	0.356647	0.019164	0.000025	0.000023	0.005977	3.206562	19.7193	461.6777
0.3368	0.1768	0.1678	0.2089	0.3375	0.019148	0.000031	0.000028	0.005972	3.206257	16.5131	461.6777
0.3176	0.164	0.1615	0.2252	0.318373	0.019126	0.000037	0.000034	0.005966	3.20586	13.3072	461.6777
0.2983	0.1512	0.1548	0.2442	0.299276	0.019097	0.000047	0.000042	0.005958	3.205334	10.1019	461.6777
0.2791	0.1385	0.1477	0.2666	0.280217	0.019059	0.000059	0.000053	0.005947	3.204631	6.8972	461.6777
0.2599	0.126	0.1401	0.2932	0.261213	0.019005	0.000077	0.000068	0.005932	3.203678	3.6936	461.6777
0.2406	0.1135	0.1321	0.3253	0.242285	0.018928	0.000102	0.000089	0.005911	3.202375	0.4912	461.6777
0.2214	0.1013	0.1237	0.3645	0.223468	0.018817	0.00014	0.000121	0.005879	3.20058	-2.7094	461.6777

The depth of flow at the **upper** end of the reach is **0.2377 ft**.

Flow has returned to normal. The flow depth returned to normal 0.00 ft from the downstream lower end of reach.

Node and Reach invert report

Node and Reach invert report				
Node	co2		Out ie	470.10 ft
	Reach	p-co2	I.E. Out	470.10 ft
Node	co1		Out ie	470.25 ft
	Reach	p-co1	I.E. Out	470.25 ft
Node	co3		Out ie	465.03 ft
	Reach	p-co3	I.E. Out	465.03 ft
Node	co5		Out ie	456.07 ft
	Reach	p-co5	I.E. Out	456.07 ft
Node	cb20		Out ie	459.00 ft
	Reach	p20	I.E. Out	459.00 ft
Node	cb19		Out ie	458.43 ft
	Reach	p20	I.E. In	458.43 ft

	Reach	p19	I.E. Out	458.43 ft
Node	cb18		Out ie	456.97 ft
	Reach	p19	I.E. In	456.97 ft
	Reach	p18	I.E. Out	456.97 ft
Node	cb17		Out ie	455.77 ft
	Reach	p-co5	I.E. In	455.77 ft
	Reach	p18	I.E. In	455.77 ft
	Reach	p17	I.E. Out	455.77 ft
Node	cb16		Out ie	454.77 ft
	Reach	p17	I.E. In	454.77 ft
	Reach	p16	I.E. Out	454.77 ft
Node	cb15		Out ie	455.33 ft
	Reach	p15	I.E. Out	454.96 ft
Node	cb14		Out ie	454.43 ft
	Reach	p16	I.E. In	454.43 ft
	Reach	p15	I.E. In	454.43 ft
	Reach	p14	I.E. Out	454.43 ft
Node	cb13		Out ie	459.83 ft
	Reach	p13	I.E. Out	459.83 ft
Node	cb12		Out ie	454.04 ft
	Reach	p14	I.E. In	454.04 ft
	Reach	p13	I.E. In	454.04 ft
	Reach	p12	I.E. Out	454.04 ft
Node	co9		Out ie	461.65 ft
	Reach	p-co9	I.E. Out	461.65 ft
Node	cb11		Out ie	461.22 ft
	Reach	p-co9	I.E. In	461.22 ft
	Reach	p11	I.E. Out	461.22 ft
Node	cb10		Out ie	453.74 ft
	Reach	p12	I.E. In	453.74 ft
	Reach	p11	I.E. In	453.74 ft
	Reach	p10	I.E. Out	453.74 ft
Node	co6		Out ie	462.71 ft
	Reach	p-co6	I.E. Out	462.71 ft
Node	cb9		Out ie	461.88 ft
	Reach	p-co6	I.E. In	461.87 ft
	Reach	p9	I.E. Out	461.88 ft
Node	cb8		Out ie	461.44 ft
	Reach	p8	I.E. Out	461.44 ft
Node	cb7		Out ie	461.11 ft
	Reach	p9	I.E. In	461.11 ft

	Reach	p8	I.E. In	461.11 ft
	Reach	p7	I.E. Out	461.11 ft
Node	cb6		Out ie	453.625 ft
	Reach	p10	I.E. In	453.63 ft
	Reach	p7	I.E. In	453.63 ft
	Reach	p6	I.E. Out	453.625 ft
Node	cb5		Out ie	453.38 ft
	Reach	p-co3	I.E. In	453.48 ft
	Reach	p6	I.E. In	453.38 ft
	Reach	p5	I.E. Out	453.38 ft
Node	cb4		Out ie	452.75 ft
	Reach	p5	I.E. In	452.75 ft
	Reach	p4	I.E. Out	452.75 ft
Node	cb3		Out ie	452.08 ft
	Reach	p-co2	I.E. In	452.18 ft
	Reach	p-co1	I.E. In	452.01 ft
	Reach	p4	I.E. In	452.08 ft
	Reach	p3	I.E. Out	452.08 ft
Node	cb2		Out ie	451.205 ft
	Reach	p3	I.E. In	451.205 ft
	Reach	p2	I.E. Out	451.205 ft
Node	cb1		Out ie	450.34 ft
	Reach	p2	I.E. In	450.34 ft
	Reach	p1	I.E. Out	450.34 ft

Licensed to: Barghausen Consulting Engineers

Appended on: Friday, May 12, 2017 4:46:30 PM

Layout Report: 16718pipe

Event	Precip (in)
6 month	1.44
2 yr 24 hr	2.00
10 year	3.00
25 year	3.50
100 year	4.10

Reach Records

Record Id: p1

Section Shape:	Circular		
Uniform Flow Method:	Manning's	Coefficient:	0.012
Routing Method:	Travel Time Shift	Contributing Hyd	
DnNode	pond	UpNode	cb1
Material	unspecified	Size	24 in Diam
Ent Losses	Groove End w/Headwall		
Length	54.00 ft	Slope	0.63%
Up Invert	450.34 ft	Dn Invert	450.00 ft
Conduit Constraints			
Min Vel	Max Vel	Min Slope	Max Slope
2.00 ft/s	15.00 ft/s	0.50%	2.00%
Drop across MH	0.00 ft	Ex/Infil Rate	0.00 in/hr

Record Id: p10

Section Shape:	Circular		
Uniform Flow Method:	Manning's	Coefficient:	0.012
Routing Method:	Travel Time Shift	Contributing Hyd	
DnNode	cb6	UpNode	cb10
Material	unspecified	Size	18 in Diam
Ent Losses	Groove End w/Headwall		
Length	22.00 ft	Slope	0.50%
Up Invert	453.74 ft	Dn Invert	453.63 ft

Conduit Constraints

Min Vel	Max Vel	Min Slope	Max Slope	Min Cover
2.00 ft/s	15.00 ft/s	0.50%	2.00%	3.00 ft
Drop across MH		0.00 ft	Ex/Infil Rate	0.00 in/hr

Record Id: p11

Section Shape:	Circular			
Uniform Flow Method:	Manning's	Coefficient:	0.012	
Routing Method:	Travel Time Shift	Contributing Hyd		
DnNode	cb10	UpNode	cb11	
Material	unspecified	Size	12 in Diam	
Ent Losses	Groove End w/Headwall			
Length	187.00 ft	Slope	4.00%	
Up Invert	461.22 ft	Dn Invert	453.74 ft	
Conduit Constraints				
Min Vel	Max Vel	Min Slope	Max Slope	Min Cover
2.00 ft/s	15.00 ft/s	0.50%	2.00%	3.00 ft
Drop across MH		0.00 ft	Ex/Infil Rate	0.00 in/hr

Record Id: p12

Section Shape:	Circular			
Uniform Flow Method:	Manning's	Coefficient:	0.012	
Routing Method:	Travel Time Shift	Contributing Hyd		
DnNode	cb10	UpNode	cb12	
Material	unspecified	Size	18 in Diam	
Ent Losses	Groove End w/Headwall			
Length	60.00 ft	Slope	0.50%	
Up Invert	454.04 ft	Dn Invert	453.74 ft	
Conduit Constraints				
Min Vel	Max Vel	Min Slope	Max Slope	Min Cover
2.00 ft/s	15.00 ft/s	0.50%	2.00%	3.00 ft
Drop across MH		0.00 ft	Ex/Infil Rate	0.00 in/hr

Record Id: p13

Section Shape:	Circular			
-----------------------	----------	--	--	--

Uniform Flow Method:	Manning's	Coefficient:	0.012
Routing Method:	Travel Time Shift	Contributing Hyd	
DnNode	cb12	UpNode	cb13
Material	unspecified	Size	8 in Diam
Ent Losses	Groove End w/Headwall		
Length	64.00 ft	Slope	9.05%
Up Invert	459.83 ft	Dn Invert	454.04 ft
Conduit Constraints			
Min Vel	Max Vel	Min Slope	Max Slope
2.00 ft/s	15.00 ft/s	0.50%	2.00%
Drop across MH		0.00 ft	Ex/Infil Rate
			0.00 in/hr

Record Id: p14

Section Shape:	Circular		
Uniform Flow Method:	Manning's	Coefficient:	0.012
Routing Method:	Travel Time Shift	Contributing Hyd	
DnNode	cb12	UpNode	cb14
Material	unspecified	Size	15 in Diam
Ent Losses	Groove End w/Headwall		
Length	78.00 ft	Slope	0.50%
Up Invert	454.43 ft	Dn Invert	454.04 ft
Conduit Constraints			
Min Vel	Max Vel	Min Slope	Max Slope
2.00 ft/s	15.00 ft/s	0.50%	2.00%
Drop across MH		0.00 ft	Ex/Infil Rate
			0.00 in/hr

Record Id: p15

Section Shape:	Circular		
Uniform Flow Method:	Manning's	Coefficient:	0.012
Routing Method:	Travel Time Shift	Contributing Hyd	
DnNode	cb14	UpNode	cb15
Material	unspecified	Size	8 in Diam
Ent Losses	Groove End w/Headwall		
Length	106.00 ft	Slope	0.50%
Up Invert	454.96 ft	Dn Invert	454.43 ft
Conduit Constraints			
Min Vel	Max Vel	Min Slope	Max Slope
2.00 ft/s	15.00 ft/s	0.50%	2.00%
Drop across MH		0.00 ft	Ex/Infil Rate
			0.00 in/hr

Conduit Constraints				
Min Vel	Max Vel	Min Slope	Max Slope	Min Cover
2.00 ft/s	15.00 ft/s	0.50%	2.00%	3.00 ft
Drop across MH		0.00 ft	Ex/Infil Rate	0.00 in/hr

Record Id: p16

Section Shape:	Circular			
Uniform Flow Method:	Manning's	Coefficient:	0.012	
Routing Method:	Travel Time Shift	Contributing Hyd		
DnNode	cb14	UpNode	cb16	
Material	unspecified	Size	12 in Diam	
Ent Losses	Groove End w/Headwall			
Length	34.00 ft	Slope	1.00%	
Up Invert	454.77 ft	Dn Invert	454.43 ft	
Conduit Constraints				
Min Vel	Max Vel	Min Slope	Max Slope	Min Cover
2.00 ft/s	15.00 ft/s	0.50%	2.00%	3.00 ft
Drop across MH		0.00 ft	Ex/Infil Rate	0.00 in/hr

Record Id: p17

Section Shape:	Circular			
Uniform Flow Method:	Manning's	Coefficient:	0.012	
Routing Method:	Travel Time Shift	Contributing Hyd		
DnNode	cb16	UpNode	cb17	
Material	unspecified	Size	12 in Diam	
Ent Losses	Groove End w/Headwall			
Length	100.00 ft	Slope	1.00%	
Up Invert	455.77 ft	Dn Invert	454.77 ft	
Conduit Constraints				
Min Vel	Max Vel	Min Slope	Max Slope	Min Cover
2.00 ft/s	15.00 ft/s	0.50%	2.00%	3.00 ft
Drop across MH		0.00 ft	Ex/Infil Rate	0.00 in/hr

Record Id: p18

Section Shape:	Circular			
-----------------------	----------	--	--	--

Uniform Flow Method:	Manning's	Coefficient:	0.012
Routing Method:	Travel Time Shift	Contributing Hyd	
DnNode	cb17	UpNode	cb18
Material	Closed Conduits, Concrete Pipe	Size	12 in Diam
Ent Losses	Groove End w/Headwall		
Length	200.00 ft	Slope	0.60%
Up Invert	456.97 ft	Dn Invert	455.77 ft
Conduit Constraints			
Min Vel	Max Vel	Min Slope	Max Slope
2.00 ft/s	15.00 ft/s	0.50%	2.00%
Drop across MH		0.00 ft	Ex/Infil Rate
			0.00 in/hr

Record Id: p19

Section Shape:	Circular		
Uniform Flow Method:	Manning's	Coefficient:	0.012
Routing Method:	Travel Time Shift	Contributing Hyd	
DnNode	cb18	UpNode	cb19
Material	unspecified	Size	12 in Diam
Ent Losses	Groove End w/Headwall		
Length	242.00 ft	Slope	0.60%
Up Invert	458.43 ft	Dn Invert	456.97 ft
Conduit Constraints			
Min Vel	Max Vel	Min Slope	Max Slope
2.00 ft/s	15.00 ft/s	0.50%	2.00%
Drop across MH		0.00 ft	Ex/Infil Rate
			0.00 in/hr

Record Id: p2

Section Shape:	Circular		
Uniform Flow Method:	Manning's	Coefficient:	0.012
Routing Method:	Travel Time Shift	Contributing Hyd	
DnNode	cb1	UpNode	cb2
Material	unspecified	Size	24 in Diam
Ent Losses	Groove End w/Headwall		
Length	173.00 ft	Slope	0.50%
Up Invert	451.205 ft	Dn Invert	450.34 ft
Conduit Constraints			
Min Vel	Max Vel	Min Slope	Max Slope
2.00 ft/s	15.00 ft/s	0.50%	2.00%
Drop across MH		0.00 ft	Ex/Infil Rate
			0.00 in/hr

Conduit Constraints				
Min Vel	Max Vel	Min Slope	Max Slope	Min Cover
2.00 ft/s	15.00 ft/s	0.50%	2.00%	3.00 ft
Drop across MH		0.00 ft	Ex/Infil Rate	0.00 in/hr

Record Id: p20

Section Shape:	Circular			
Uniform Flow Method:	Manning's	Coefficient:	0.012	
Routing Method:	Travel Time Shift	Contributing Hyd		
DnNode	cb19	UpNode	cb20	
Material	unspecified	Size	12 in Diam	
Ent Losses	Groove End w/Headwall			
Length	114.00 ft	Slope	0.50%	
Up Invert	459.00 ft	Dn Invert	458.43 ft	
Conduit Constraints				
Min Vel	Max Vel	Min Slope	Max Slope	Min Cover
2.00 ft/s	15.00 ft/s	0.50%	2.00%	3.00 ft
Drop across MH		0.00 ft	Ex/Infil Rate	0.00 in/hr

Record Id: p3

Section Shape:	Circular			
Uniform Flow Method:	Manning's	Coefficient:	0.012	
Routing Method:	Travel Time Shift	Contributing Hyd		
DnNode	cb2	UpNode	cb3	
Material	unspecified	Size	21 in Diam	
Ent Losses	Groove End w/Headwall			
Length	175.00 ft	Slope	0.50%	
Up Invert	452.08 ft	Dn Invert	451.205 ft	
Conduit Constraints				
Min Vel	Max Vel	Min Slope	Max Slope	Min Cover
2.00 ft/s	15.00 ft/s	0.50%	2.00%	3.00 ft
Drop across MH		0.00 ft	Ex/Infil Rate	0.00 in/hr

Record Id: p4

Section Shape:	Circular			
-----------------------	----------	--	--	--

Uniform Flow Method:	Manning's	Coefficient:	0.012
Routing Method:	Travel Time Shift	Contributing Hyd	
DnNode	cb3	UpNode	cb4
Material	unspecified	Size	18 in Diam
Ent Losses	Groove End w/Headwall		
Length	134.00 ft	Slope	0.50%
Up Invert	452.75 ft	Dn Invert	452.08 ft
Conduit Constraints			
Min Vel	Max Vel	Min Slope	Max Slope
2.00 ft/s	15.00 ft/s	0.50%	2.00%
Drop across MH		0.00 ft	Ex/Infil Rate
			0.00 in/hr

Record Id: p5

Section Shape:	Circular		
Uniform Flow Method:	Manning's	Coefficient:	0.012
Routing Method:	Travel Time Shift	Contributing Hyd	
DnNode	cb4	UpNode	cb5
Material	unspecified	Size	18 in Diam
Ent Losses	Groove End w/Headwall		
Length	126.00 ft	Slope	0.50%
Up Invert	453.38 ft	Dn Invert	452.75 ft
Conduit Constraints			
Min Vel	Max Vel	Min Slope	Max Slope
2.00 ft/s	15.00 ft/s	0.50%	2.00%
Drop across MH		0.00 ft	Ex/Infil Rate
			0.00 in/hr

Record Id: p6

Section Shape:	Circular		
Uniform Flow Method:	Manning's	Coefficient:	0.012
Routing Method:	Travel Time Shift	Contributing Hyd	
DnNode	cb5	UpNode	cb6
Material	unspecified	Size	18 in Diam
Ent Losses	Groove End w/Headwall		
Length	49.00 ft	Slope	0.50%
Up Invert	453.625 ft	Dn Invert	453.38 ft
Conduit Constraints			
Min Vel	Max Vel	Min Slope	Max Slope
2.00 ft/s	15.00 ft/s	0.50%	2.00%
Drop across MH		0.00 ft	Ex/Infil Rate
			0.00 in/hr

Conduit Constraints				
Min Vel	Max Vel	Min Slope	Max Slope	Min Cover
2.00 ft/s	15.00 ft/s	0.50%	2.00%	3.00 ft
Drop across MH		0.00 ft	Ex/Infil Rate	0.00 in/hr

Record Id: p7

Section Shape:	Circular			
Uniform Flow Method:	Manning's	Coefficient:	0.012	
Routing Method:	Travel Time Shift	Contributing Hyd		
DnNode	cb6	UpNode	cb7	
Material	unspecified	Size	12 in Diam	
Ent Losses	Groove End w/Headwall			
Length	75.00 ft	Slope	9.97%	
Up Invert	461.11 ft	Dn Invert	453.63 ft	
Conduit Constraints				
Min Vel	Max Vel	Min Slope	Max Slope	Min Cover
2.00 ft/s	15.00 ft/s	0.50%	2.00%	3.00 ft
Drop across MH		0.00 ft	Ex/Infil Rate	0.00 in/hr

Record Id: p8

Section Shape:	Circular			
Uniform Flow Method:	Manning's	Coefficient:	0.012	
Routing Method:	Travel Time Shift	Contributing Hyd		
DnNode	cb7	UpNode	cb8	
Material	unspecified	Size	8 in Diam	
Ent Losses	Groove End w/Headwall			
Length	55.00 ft	Slope	0.60%	
Up Invert	461.44 ft	Dn Invert	461.11 ft	
Conduit Constraints				
Min Vel	Max Vel	Min Slope	Max Slope	Min Cover
2.00 ft/s	15.00 ft/s	0.50%	2.00%	3.00 ft
Drop across MH		0.00 ft	Ex/Infil Rate	0.00 in/hr

Record Id: p9

Section Shape:	Circular			
-----------------------	----------	--	--	--

Uniform Flow Method:	Manning's	Coefficient:	0.012
Routing Method:	Travel Time Shift	Contributing Hyd	
DnNode	cb7	UpNode	cb9
Material	unspecified	Size	12 in Diam
Ent Losses	Groove End w/Headwall		
Length	140.00 ft	Slope	0.55%
Up Invert	461.88 ft	Dn Invert	461.11 ft
Conduit Constraints			
Min Vel	Max Vel	Min Slope	Max Slope
2.00 ft/s	15.00 ft/s	0.50%	2.00%
Drop across MH		0.00 ft	Ex/Infil Rate
			0.00 in/hr

Record Id: p-co1

Section Shape:	Circular		
Uniform Flow Method:	Manning's	Coefficient:	0.012
Routing Method:	Travel Time Shift	Contributing Hyd	
DnNode	cb3	UpNode	co1
Material	Closed Conduits, Concrete Pipe	Size	8 in Diam
Ent Losses	Groove End w/Headwall		
Length	96.00 ft	Slope	19.00%
Up Invert	470.25 ft	Dn Invert	452.01 ft
Conduit Constraints			
Min Vel	Max Vel	Min Slope	Max Slope
2.00 ft/s	15.00 ft/s	0.50%	2.00%
Drop across MH		0.00 ft	Ex/Infil Rate
			0.00 in/hr

Record Id: p-co2

Section Shape:	Circular		
Uniform Flow Method:	Manning's	Coefficient:	0.012
Routing Method:	Travel Time Shift	Contributing Hyd	
DnNode	cb3	UpNode	co2
Material	Closed Conduits, Concrete Pipe	Size	6 in Diam
Ent Losses	Groove End w/Headwall		
Length	64.00 ft	Slope	28.00%
Up Invert	470.10 ft	Dn Invert	452.18 ft
Conduit Constraints			
Min Vel	Max Vel	Min Slope	Max Slope
2.00 ft/s	15.00 ft/s	0.50%	2.00%
Drop across MH		0.00 ft	Ex/Infil Rate
			0.00 in/hr

Conduit Constraints				
Min Vel	Max Vel	Min Slope	Max Slope	Min Cover
2.00 ft/s	15.00 ft/s	0.50%	2.00%	3.00 ft
Drop across MH		0.00 ft	Ex/Infil Rate	0.00 in/hr

Record Id: p-co3

Section Shape:	Circular			
Uniform Flow Method:	Manning's	Coefficient:	0.012	
Routing Method:	Travel Time Shift	Contributing Hyd		
DnNode	cb5	UpNode	co3	
Material	unspecified	Size	6 in Diam	
Ent Losses	Groove End w/Headwall			
Length	33.00 ft	Slope	35.00%	
Up Invert	465.03 ft	Dn Invert	453.48 ft	
Conduit Constraints				
Min Vel	Max Vel	Min Slope	Max Slope	Min Cover
2.00 ft/s	15.00 ft/s	0.50%	2.00%	3.00 ft
Drop across MH		0.00 ft	Ex/Infil Rate	0.00 in/hr

Record Id: p-co5

Section Shape:	Circular			
Uniform Flow Method:	Manning's	Coefficient:	0.012	
Routing Method:	Travel Time Shift	Contributing Hyd		
DnNode	cb17	UpNode	co5	
Material	Closed Conduits, Concrete Pipe	Size	6 in Diam	
Ent Losses	Groove End w/Headwall			
Length	15.00 ft	Slope	2.00%	
Up Invert	456.07 ft	Dn Invert	455.77 ft	
Conduit Constraints				
Min Vel	Max Vel	Min Slope	Max Slope	Min Cover
2.00 ft/s	15.00 ft/s	0.50%	2.00%	3.00 ft
Drop across MH		0.00 ft	Ex/Infil Rate	0.00 in/hr

Record Id: p-co6

Section Shape:	Circular			
-----------------------	----------	--	--	--

Uniform Flow Method:	Manning's	Coefficient:	0.012
Routing Method:	Travel Time Shift	Contributing Hyd	
DnNode	cb9	UpNode	co6
Material	unspecified	Size	6 in Diam
Ent Losses	Groove End w/Headwall		
Length	42.00 ft	Slope	2.00%
Up Invert	462.71 ft	Dn Invert	461.87 ft
Conduit Constraints			
Min Vel	Max Vel	Min Slope	Max Slope
2.00 ft/s	15.00 ft/s	0.50%	2.00%
Drop across MH		0.00 ft	Ex/Infil Rate
			0.00 in/hr

Record Id: p-co9

Section Shape:	Circular		
Uniform Flow Method:	Manning's	Coefficient:	0.011
Routing Method:	Travel Time Shift	Contributing Hyd	
DnNode	cb11	UpNode	co9
Material	unspecified	Size	8 in Diam
Ent Losses	Groove End w/Headwall		
Length	21.00 ft	Slope	2.05%
Up Invert	461.65 ft	Dn Invert	461.22 ft
Conduit Constraints			
Min Vel	Max Vel	Min Slope	Max Slope
2.00 ft/s	15.00 ft/s	0.50%	2.00%
Drop across MH		0.00 ft	Ex/Infil Rate
			0.00 in/hr

Node Records**Record Id: cb1**

Descrip:	Prototype Record	Increment	0.10 ft
Start El.	450.34 ft	Max El.	459.56 ft
Void Ratio	100.00		
Condition	Existing	Structure Type	CB-TYPE 2-48
		Channelization	No Special Shape
Catch	0.00 ft	Bottom Area	12.5664 sf
MH/CB Type Node			

Record Id: cb10

Descrip:	Prototype Record	Increment	0.10 ft
Start El.	453.74 ft	Max El.	470.90 ft
Void Ratio	100.00		
Condition	Existing	Structure Type	CB-TYPE 2-48
		Channelization	No Special Shape
Catch	0.00 ft	Bottom Area	12.5664 sf
MH/CB Type Node			

Record Id: cb11

Descrip:	Prototype Record	Increment	0.10 ft
Start El.	461.22 ft	Max El.	465.30 ft
Void Ratio	100.00		
Condition	Existing	Structure Type	CB-TYPE 1-48
		Channelization	No Special Shape
Catch	0.00 ft	Bottom Area	12.5664 sf
MH/CB Type Node			

Record Id: cb12

Descrip:	Prototype Record	Increment	0.10 ft
Start El.	454.04 ft	Max El.	469.50 ft
Void Ratio	100.00		
Condition	Existing	Structure Type	CB-TYPE 2-48
		Channelization	No Special Shape
Catch	0.00 ft	Bottom Area	12.5664 sf
MH/CB Type Node			

Record Id: cb13

Descrip:	Prototype Record	Increment	0.10 ft
Start El.	459.83 ft	Max El.	464.00 ft
Void Ratio	100.00		
Condition	Existing	Structure Type	CB-TYPE 1
		Channelization	No Special Shape
Catch	0.00 ft	Bottom Area	3.97 sf
MH/CB Type Node			

Record Id: cb14

Descrip:	Prototype Record	Increment	0.10 ft
Start El.	454.43 ft	Max El.	467.85 ft
Void Ratio	100.00		
Condition	Existing	Structure Type	CB-TYPE 2-48
		Channelization	No Special Shape
Catch	0.00 ft	Bottom Area	12.5664 sf
MH/CB Type Node			

Record Id: cb15

Descrip:	Prototype Record	Increment	0.10 ft
Start El.	455.33 ft	Max El.	457.00 ft
Void Ratio	100.00		
Condition	Existing	Structure Type	CB-TYPE 1
		Channelization	No Special Shape
Catch	0.00 ft	Bottom Area	3.97 sf
MH/CB Type Node			

Record Id: cb16

Descrip:	Prototype Record	Increment	0.10 ft
Start El.	454.77 ft	Max El.	467.50 ft
Void Ratio	100.00		
Condition	Existing	Structure Type	CB-TYPE 2-48
		Channelization	No Special Shape
Catch	0.00 ft	Bottom Area	12.5664 sf
MH/CB Type Node			

Record Id: cb17

Descrip:	Prototype Record	Increment	0.10 ft
Start El.	455.77 ft	Max El.	467.00 ft
Void Ratio	100.00		
Condition	Existing	Structure Type	CB-TYPE 2-48
		Channelization	No Special Shape
Catch	0.00 ft	Bottom Area	12.5664 sf
MH/CB Type Node			

Record Id: cb18

Descrip:	Prototype Record	Increment	0.10 ft
Start El.	456.97 ft	Max El.	467.00 ft
Void Ratio	100.00		
Condition	Existing	Structure Type	CB-TYPE 2-48
		Channelization	No Special Shape
Catch	0.00 ft	Bottom Area	12.5664 sf
MH/CB Type Node			

Record Id: cb19

Descrip:	Prototype Record	Increment	0.10 ft
Start El.	458.43 ft	Max El.	465.40 ft
Void Ratio	100.00		
Condition	Existing	Structure Type	CB-TYPE 2-48
		Channelization	No Special Shape
Catch	0.00 ft	Bottom Area	12.5664 sf
MH/CB Type Node			

Record Id: cb2

Descrip:	Prototype Record	Increment	0.10 ft
Start El.	451.205 ft	Max El.	471.20 ft
Void Ratio	100.00		
Condition	Existing	Structure Type	CB-TYPE 2-48
		Channelization	No Special Shape
Catch	0.00 ft	Bottom Area	12.5664 sf
MH/CB Type Node			

Record Id: cb20

Descrip:	Prototype Record	Increment	0.10 ft
Start El.	459.00 ft	Max El.	462.00 ft
Void Ratio	100.00		
Condition	Existing	Structure Type	CB-TYPE 1
		Channelization	No Special Shape
Catch	0.00 ft	Bottom Area	3.97 sf
MH/CB Type Node			

Record Id: cb3

Descrip:	Prototype Record	Increment	0.10 ft
Start El.	452.08 ft	Max El.	472.80 ft
Void Ratio	100.00		
Condition	Existing	Structure Type	CB-TYPE 2-48
		Channelization	No Special Shape
Catch	0.00 ft	Bottom Area	12.5664 sf
MH/CB Type Node			

Record Id: cb4

Descrip:	Prototype Record	Increment	0.10 ft
Start El.	452.75 ft	Max El.	472.80 ft
Void Ratio	100.00		
Condition	Existing	Structure Type	CB-TYPE 2-48
		Channelization	No Special Shape
Catch	0.00 ft	Bottom Area	12.5664 sf
MH/CB Type Node			

Record Id: cb5

Descrip:	Prototype Record	Increment	0.10 ft
Start El.	453.38 ft	Max El.	472.70 ft
Void Ratio	100.00		
Condition	Existing	Structure Type	CB-TYPE 2-48
		Channelization	No Special Shape
Catch	0.00 ft	Bottom Area	12.5664 sf
MH/CB Type Node			

Record Id: cb6

Descrip:	Prototype Record	Increment	0.10 ft
Start El.	453.625 ft	Max El.	470.79 ft
Void Ratio	100.00		
Condition	Existing	Structure Type	CB-TYPE 2-48
		Channelization	No Special Shape
Catch	0.00 ft	Bottom Area	12.5664 sf
MH/CB Type Node			

Record Id: cb7

Descrip:	Prototype Record	Increment	0.10 ft
Start El.	461.11 ft	Max El.	467.80 ft
Void Ratio	100.00		
Condition	Existing	Structure Type	CB-TYPE 2-48
		Channelization	No Special Shape
Catch	0.00 ft	Bottom Area	12.5664 sf
MH/CB Type Node			

Record Id: cb8

Descrip:	Prototype Record	Increment	0.10 ft
Start El.	461.44 ft	Max El.	463.50 ft
Void Ratio	100.00		
Condition	Existing	Structure Type	CB-TYPE 1
		Channelization	No Special Shape
Catch	0.00 ft	Bottom Area	3.97 sf
MH/CB Type Node			

Record Id: cb9

Descrip:	Prototype Record	Increment	0.10 ft
Start El.	461.88 ft	Max El.	465.30 ft
Void Ratio	100.00		
Condition	Existing	Structure Type	CB-TYPE 1
		Channelization	No Special Shape
Catch	0.00 ft	Bottom Area	3.97 sf
MH/CB Type Node			

Record Id: co1

Descrip:	Prototype Record	Increment	0.10 ft
Start El.	470.25 ft	Max El.	475.00 ft
Void Ratio	100.00		
Condition	Existing	Structure Type	CB-TYPE 1-48
		Channelization	No Special Shape
Catch	0.00 ft	Bottom Area	19.635 sf
MH/CB Type Node			

Record Id: co2

Descrip:	Prototype Record	Increment	0.10 ft
Start El.	470.10 ft	Max El.	474.50 ft
Void Ratio	100.00		
Condition	Existing	Structure Type	CB-TYPE 1
		Channelization	No Special Shape
Catch	0.00 ft	Bottom Area	3.97 sf
MH/CB Type Node			

Record Id: co3

Descrip:	Prototype Record	Increment	0.10 ft
Start El.	465.03 ft	Max El.	474.88 ft
Void Ratio	100.00		
Condition	Existing	Structure Type	CB-TYPE 1
		Channelization	No Special Shape
Catch	0.00 ft	Bottom Area	3.97 sf
MH/CB Type Node			

Record Id: co5

Descrip:	Prototype Record	Increment	0.10 ft
Start El.	456.07 ft	Max El.	468.00 ft
Void Ratio	100.00		
Condition	Existing	Structure Type	CB-TYPE 1
		Channelization	No Special Shape
Catch	0.00 ft	Bottom Area	3.97 sf
MH/CB Type Node			

Record Id: co6

Descrip:	Prototype Record	Increment	0.10 ft
Start El.	462.71 ft	Max El.	468.00 ft
Void Ratio	100.00		
Condition	Existing	Structure Type	CB-TYPE 1
		Channelization	No Special Shape
Catch	0.00 ft	Bottom Area	3.97 sf
MH/CB Type Node			

Record Id: co9

Descrip:	Prototype Record	Increment	0.10 ft
Start El.	461.65 ft	Max El.	468.00 ft
Void Ratio	100.00		
Condition	Existing	Structure Type	CB-TYPE 1
		Channelization	No Special Shape
Catch	0.00 ft	Bottom Area	3.97 sf
MH/CB Type Node			

Record Id: pond

Descrip:	Prototype Record	Increment	0.10 ft
Start El.	450.00 ft	Max El.	459.00 ft
Void Ratio	100.00		
Dummy Type Node			

Contributing Drainage Areas**Record Id: cb10**

Design Method	SBUH	Rainfall type	TYPE1A.RAC			
Hyd Intv	10.00 min	Peaking Factor	484.00			
Storm Duration	24.00 hrs	Abstraction Coeff	0.20			
Pervious Area	0.00 ac	DCIA	0.01 ac			
Pervious CN	0.00	DC CN	98.00			
Pervious TC	5.00 min	DC TC	5.00 min			
Pervious TC Calc						
Type	Description	Length	Slope	Coeff	Misc	TT
Sheet		0.00 ft	0.0%	5.0	0.00 in	5.00 min
Pervious TC						5.00 min
DCI - CN Calc						
Description					SubArea	Sub cn
Impervious surfaces (pavements, roofs, etc)					0.01 ac	98.00
DC Compositied CN (AMC 2)						98.00
DCI - TC Calc						
Type	Description	Length	Slope	Coeff	Misc	TT

Sheet	0.00 ft	0.0%	5.0	0.00 in	5.00 min
Pervious TC					5.00 min

Record Id: cb11

Design Method	SBUH	Rainfall type			TYPE1A.RAC	
Hyd Intv	10.00 min	Peaking Factor			484.00	
Storm Duration	24.00 hrs	Abstraction Coeff			0.20	
Pervious Area	0.25 ac	DCIA			0.36 ac	
Pervious CN	86.00	DC CN			98.00	
Pervious TC	5.00 min	DC TC			5.00 min	
Pervious CN Calc						
Description				SubArea	Sub cn	
Open spaces, lawns,parks (>75% grass)				0.25 ac	86.00	
Pervious Compositd CN (AMC 2)					86.00	
Pervious TC Calc						
Type	Description	Length	Slope	Coeff	Misc	TT
Sheet		0.00 ft	0.0%	5.0	0.00 in	5.00 min
Pervious TC						5.00 min
DCI - CN Calc						
Description				SubArea	Sub cn	
Impervious surfaces (pavements, roofs, etc)				0.36 ac	98.00	
DC Compositd CN (AMC 2)					98.00	
DCI - TC Calc						
Type	Description	Length	Slope	Coeff	Misc	TT
Sheet		0.00 ft	0.0%	5.0	0.00 in	5.00 min
Pervious TC						5.00 min

Record Id: cb12

Design Method	SBUH	Rainfall type			TYPE1A.RAC
Hyd Intv	10.00 min	Peaking Factor			484.00
Storm Duration	24.00 hrs	Abstraction Coeff			0.20
Pervious Area	0.01 ac	DCIA			0.02 ac
Pervious CN	86.00	DC CN			98.00
Pervious TC	5.00 min	DC TC			5.00 min

Pervious CN Calc						
Description				SubArea	Sub cn	
Open spaces, lawns,parks (>75% grass)				0.01 ac	86.00	
Pervious Compositced CN (AMC 2)				86.00		

Pervious TC Calc						
Type	Description	Length	Slope	Coeff	Misc	TT
Sheet		0.00 ft	0.0%	5.0	0.00 in	5.00 min
Pervious TC						5.00 min

DCI - CN Calc			
Description		SubArea	Sub cn
Impervious surfaces (pavements, roofs, etc)		0.02 ac	98.00
DC Compositced CN (AMC 2)		98.00	

DCI - TC Calc						
Type	Description	Length	Slope	Coeff	Misc	TT
Sheet		0.00 ft	0.0%	5.0	0.00 in	5.00 min
Pervious TC						5.00 min

Record Id: cb13

Design Method	SBUH	Rainfall type	TYPE1A.RAC			
Hyd Intv	10.00 min	Peaking Factor	484.00			
Storm Duration	24.00 hrs	Abstraction Coeff	0.20			
Pervious Area	0.00 ac	DCIA	0.07 ac			
Pervious CN	0.00	DC CN	98.00			
Pervious TC	0.00 min	DC TC	5.00 min			

DCI - CN Calc			
Description		SubArea	Sub cn
Impervious surfaces (pavements, roofs, etc)		0.07 ac	98.00
DC Compositced CN (AMC 2)		98.00	

DCI - TC Calc						
Type	Description	Length	Slope	Coeff	Misc	TT
Sheet		0.00 ft	0.0%	5.0	0.00 in	5.00 min
Pervious TC						5.00 min

Record Id: cb14

--	--	--	--	--	--	--

Design Method	SBUH	Rainfall type	TYPE1A.RAC			
Hyd Intv	10.00 min	Peaking Factor	484.00			
Storm Duration	24.00 hrs	Abstraction Coeff	0.20			
Pervious Area	0.04 ac	DCIA	0.08 ac			
Pervious CN	86.00	DC CN	98.00			
Pervious TC	5.00 min	DC TC	5.00 min			
Pervious CN Calc						
Description					SubArea	Sub cn
Open spaces, lawns,parks (>75% grass)					0.04 ac	86.00
Pervious Compositied CN (AMC 2)					86.00	
Pervious TC Calc						
Type	Description	Length	Slope	Coeff	Misc	TT
Sheet		0.00 ft	0.0%	5.0	0.00 in	5.00 min
Pervious TC						5.00 min
DCI - CN Calc						
Description					SubArea	Sub cn
Impervious surfaces (pavements, roofs, etc)					0.08 ac	98.00
DC Compositied CN (AMC 2)					98.00	
DCI - TC Calc						
Type	Description	Length	Slope	Coeff	Misc	TT
Sheet		0.00 ft	0.0%	5.0	0.00 in	5.00 min
Pervious TC						5.00 min

Record Id: cb15

Design Method	SBUH	Rainfall type	TYPE1A.RAC			
Hyd Intv	10.00 min	Peaking Factor	484.00			
Storm Duration	24.00 hrs	Abstraction Coeff	0.20			
Pervious Area	0.00 ac	DCIA	0.08 ac			
Pervious CN	0.00	DC CN	98.00			
Pervious TC	0.00 min	DC TC	5.00 min			
DCI - CN Calc						
Description					SubArea	Sub cn
Impervious surfaces (pavements, roofs, etc)					0.08 ac	98.00
DC Compositied CN (AMC 2)					98.00	
DCI - TC Calc						

Type	Description	Length	Slope	Coeff	Misc	TT
Sheet		0.00 ft	0.0%	5.0	0.00 in	5.00 min
Pervious TC						5.00 min

Record Id: cb16

Design Method	SBUH	Rainfall type	TYPE1A.RAC			
Hyd Intv	10.00 min	Peaking Factor	484.00			
Storm Duration	24.00 hrs	Abstraction Coeff	0.20			
Pervious Area	0.10 ac	DCIA	0.40 ac			
Pervious CN	86.00	DC CN	98.00			
Pervious TC	5.00 min	DC TC	5.00 min			
Pervious CN Calc						
Description					SubArea	Sub cn
Open spaces, lawns,parks (>75% grass)					0.10 ac	86.00
Pervious Compositd CN (AMC 2)					86.00	
Pervious TC Calc						
Type	Description	Length	Slope	Coeff	Misc	TT
Sheet		0.00 ft	0.0%	5.0	0.00 in	5.00 min
Pervious TC						5.00 min
DCI - CN Calc						
Description					SubArea	Sub cn
Impervious surfaces (pavements, roofs, etc)					0.40 ac	98.00
DC Compositd CN (AMC 2)					98.00	
DCI - TC Calc						
Type	Description	Length	Slope	Coeff	Misc	TT
Sheet		0.00 ft	0.0%	5.0	0.00 in	5.00 min
Pervious TC						5.00 min

Record Id: cb17

Design Method	SBUH	Rainfall type	TYPE1A.RAC			
Hyd Intv	10.00 min	Peaking Factor	484.00			
Storm Duration	24.00 hrs	Abstraction Coeff	0.20			
Pervious Area	0.00 ac	DCIA	0.25 ac			
Pervious CN	0.00	DC CN	98.00			
Pervious TC	5.00 min	DC TC	5.00 min			

Pervious TC Calc						
Type	Description	Length	Slope	Coeff	Misc	TT
Sheet		0.00 ft	0.0%	5.0	0.00 in	5.00 min
Pervious TC						5.00 min

DCI - CN Calc		
Description	SubArea	Sub cn
Impervious surfaces (pavements, roofs, etc)	0.25 ac	98.00
DC Compositd CN (AMC 2)		98.00

DCI - TC Calc						
Type	Description	Length	Slope	Coeff	Misc	TT
Sheet		0.00 ft	0.0%	5.0	0.00 in	5.00 min
Pervious TC						5.00 min

Record Id: cb18

Design Method	SBUH	Rainfall type	TYPE1A.RAC			
Hyd Intv	10.00 min	Peaking Factor	484.00			
Storm Duration	24.00 hrs	Abstraction Coeff	0.20			
Pervious Area	0.17 ac	DCIA	0.17 ac			
Pervious CN	86.00	DC CN	98.00			
Pervious TC	5.00 min	DC TC	5.00 min			

Pervious CN Calc		
Description	SubArea	Sub cn
Open spaces, lawns,parks (>75% grass)	0.17 ac	86.00
Pervious Compositd CN (AMC 2)		86.00

Pervious TC Calc						
Type	Description	Length	Slope	Coeff	Misc	TT
Sheet		0.00 ft	0.0%	5.0	0.00 in	5.00 min
Pervious TC						5.00 min

DCI - CN Calc		
Description	SubArea	Sub cn
Impervious surfaces (pavements, roofs, etc)	0.17 ac	98.00
DC Compositd CN (AMC 2)		98.00

DCI - TC Calc						
Type	Description	Length	Slope	Coeff	Misc	TT

Sheet	0.00 ft	0.0%	5.0	0.00 in	5.00 min
Pervious TC					5.00 min

Record Id: cb19

Design Method	SBUH	Rainfall type			TYPE1A.RAC	
Hyd Intv	10.00 min	Peaking Factor			484.00	
Storm Duration	24.00 hrs	Abstraction Coeff			0.20	
Pervious Area	0.22 ac	DCIA			0.10 ac	
Pervious CN	86.00	DC CN			98.00	
Pervious TC	5.00 min	DC TC			5.00 min	
Pervious CN Calc						
Description				SubArea	Sub cn	
Open spaces, lawns,parks (>75% grass)				0.22 ac	86.00	
Pervious Compositd CN (AMC 2)					86.00	
Pervious TC Calc						
Type	Description	Length	Slope	Coeff	Misc	TT
Sheet		0.00 ft	0.0%	5.0	0.00 in	5.00 min
Pervious TC						5.00 min
DCI - CN Calc						
Description				SubArea	Sub cn	
Impervious surfaces (pavements, roofs, etc)				0.10 ac	98.00	
DC Compositd CN (AMC 2)					98.00	
DCI - TC Calc						
Type	Description	Length	Slope	Coeff	Misc	TT
Sheet		0.00 ft	0.0%	5.0	0.00 in	5.00 min
Pervious TC						5.00 min

Record Id: cb2

Design Method	SBUH	Rainfall type			TYPE1A.RAC
Hyd Intv	10.00 min	Peaking Factor			484.00
Storm Duration	24.00 hrs	Abstraction Coeff			0.20
Pervious Area	0.70 ac	DCIA			0.19 ac
Pervious CN	86.00	DC CN			98.00
Pervious TC	5.00 min	DC TC			5.00 min

Pervious CN Calc						
Description					SubArea	Sub cn
Open spaces, lawns,parks (>75% grass)					0.70 ac	86.00
Pervious Compositied CN (AMC 2)						86.00
Pervious TC Calc						
Type	Description	Length	Slope	Coeff	Misc	TT
Sheet		0.00 ft	0.0%	5.0	0.00 in	5.00 min
Pervious TC						5.00 min
DCI - CN Calc						
Description					SubArea	Sub cn
Impervious surfaces (pavements, roofs, etc)					0.19 ac	98.00
DC Compositied CN (AMC 2)						98.00
DCI - TC Calc						
Type	Description	Length	Slope	Coeff	Misc	TT
Sheet		0.00 ft	0.0%	5.0	0.00 in	5.00 min
Pervious TC						5.00 min

Record Id: cb20

Design Method	SBUH	Rainfall type	TYPE1A.RAC			
Hyd Intv	10.00 min	Peaking Factor	484.00			
Storm Duration	24.00 hrs	Abstraction Coeff	0.20			
Pervious Area	0.08 ac	DCIA	0.18 ac			
Pervious CN	86.00	DC CN	98.00			
Pervious TC	5.00 min	DC TC	5.00 min			
Pervious CN Calc						
Description					SubArea	Sub cn
Open spaces, lawns,parks (>75% grass)					0.08 ac	86.00
Pervious Compositied CN (AMC 2)						86.00
Pervious TC Calc						
Type	Description	Length	Slope	Coeff	Misc	TT
Sheet		0.00 ft	0.0%	5.0	0.00 in	5.00 min
Pervious TC						5.00 min
DCI - CN Calc						
Description					SubArea	Sub cn

Impervious surfaces (pavements, roofs, etc)	0.18 ac	98.00				
DC Compositd CN (AMC 2)		98.00				
DCI - TC Calc						
Type	Description	Length	Slope	Coeff	Misc	TT
Sheet		0.00 ft	0.0%	5.0	0.00 in	5.00 min
Pervious TC						5.00 min

Record Id: cb3

Design Method	SBUH	Rainfall type	TYPE1A.RAC			
Hyd Intv	10.00 min	Peaking Factor	484.00			
Storm Duration	24.00 hrs	Abstraction Coeff	0.20			
Pervious Area	0.20 ac	DCIA	0.23 ac			
Pervious CN	86.00	DC CN	98.00			
Pervious TC	5.00 min	DC TC	5.00 min			
Pervious CN Calc						
Description		SubArea	Sub cn			
Open spaces, lawns,parks (>75% grass)		0.20 ac	86.00			
Pervious Compositd CN (AMC 2)			86.00			
Pervious TC Calc						
Type	Description	Length	Slope	Coeff	Misc	TT
Sheet		0.00 ft	0.0%	5.0	0.00 in	5.00 min
Pervious TC						5.00 min
DCI - CN Calc						
Description		SubArea	Sub cn			
Impervious surfaces (pavements, roofs, etc)		0.23 ac	98.00			
DC Compositd CN (AMC 2)			98.00			
DCI - TC Calc						
Type	Description	Length	Slope	Coeff	Misc	TT
Sheet		0.00 ft	0.0%	5.0	0.00 in	5.00 min
Pervious TC						5.00 min

Record Id: cb4

Design Method	SBUH	Rainfall type	TYPE1A.RAC
Hyd Intv	10.00 min	Peaking Factor	484.00

Storm Duration	24.00 hrs	Abstraction Coeff	0.20			
Pervious Area	0.10 ac	DCIA	0.28 ac			
Pervious CN	86.00	DC CN	98.00			
Pervious TC	5.00 min	DC TC	5.00 min			
Pervious CN Calc						
Description			SubArea	Sub cn		
Open spaces, lawns,parks (>75% grass)			0.10 ac	86.00		
Pervious Compositied CN (AMC 2)			86.00			
Pervious TC Calc						
Type	Description	Length	Slope	Coeff	Misc	TT
Sheet		0.00 ft	0.0%	5.0	0.00 in	5.00 min
Pervious TC						5.00 min
DCI - CN Calc						
Description			SubArea	Sub cn		
Impervious surfaces (pavements, roofs, etc)			0.28 ac	98.00		
DC Compositied CN (AMC 2)			98.00			
DCI - TC Calc						
Type	Description	Length	Slope	Coeff	Misc	TT
Sheet		0.00 ft	0.0%	5.0	0.00 in	5.00 min
Pervious TC						5.00 min

Record Id: cb5

Design Method	SBUH	Rainfall type	TYPE1A.RAC			
Hyd Intv	10.00 min	Peaking Factor	484.00			
Storm Duration	24.00 hrs	Abstraction Coeff	0.20			
Pervious Area	0.05 ac	DCIA	0.10 ac			
Pervious CN	86.00	DC CN	98.00			
Pervious TC	5.00 min	DC TC	5.00 min			
Pervious CN Calc						
Description			SubArea	Sub cn		
Open spaces, lawns,parks (>75% grass)			0.05 ac	86.00		
Pervious Compositied CN (AMC 2)			86.00			
Pervious TC Calc						
Type	Description	Length	Slope	Coeff	Misc	TT
Sheet		0.00 ft	0.0%	5.0	0.00 in	5.00 min

Pervious TC		5.00 min				
DCI - CN Calc						
Description	SubArea	Sub cn				
Impervious surfaces (pavements, roofs, etc)	0.10 ac	98.00				
DC Composited CN (AMC 2)		98.00				
DCI - TC Calc						
Type	Description	Length	Slope	Coeff	Misc	TT
Sheet		0.00 ft	0.0%	5.0	0.00 in	5.00 min
Pervious TC						5.00 min

Record Id: cb6

Design Method	SBUH	Rainfall type	TYPE1A.RAC			
Hyd Intv	10.00 min	Peaking Factor	484.00			
Storm Duration	24.00 hrs	Abstraction Coeff	0.20			
Pervious Area	0.02 ac	DCIA	0.04 ac			
Pervious CN	86.00	DC CN	98.00			
Pervious TC	5.00 min	DC TC	5.00 min			
Pervious CN Calc						
Description	SubArea	Sub cn				
Open spaces, lawns,parks (>75% grass)	0.02 ac	86.00				
Pervious Composited CN (AMC 2)		86.00				
Pervious TC Calc						
Type	Description	Length	Slope	Coeff	Misc	TT
Sheet		0.00 ft	0.0%	5.0	0.00 in	5.00 min
Pervious TC						5.00 min
DCI - CN Calc						
Description	SubArea	Sub cn				
Impervious surfaces (pavements, roofs, etc)	0.04 ac	98.00				
DC Composited CN (AMC 2)		98.00				
DCI - TC Calc						
Type	Description	Length	Slope	Coeff	Misc	TT
Sheet		0.00 ft	0.0%	5.0	0.00 in	5.00 min
Pervious TC						5.00 min

Record Id: cb7

Design Method	SBUH	Rainfall type		TYPE1A.RAC		
Hyd Intv	10.00 min	Peaking Factor		484.00		
Storm Duration	24.00 hrs	Abstraction Coeff		0.20		
Pervious Area	0.00 ac	DCIA		0.06 ac		
Pervious CN	0.00	DC CN		98.00		
Pervious TC	5.00 min	DC TC		5.00 min		
Pervious TC Calc						
Type	Description	Length	Slope	Coeff	Misc	TT
Sheet		0.00 ft	0.0%	5.0	0.00 in	5.00 min
Pervious TC						5.00 min
DCI - CN Calc						
Description					SubArea	Sub cn
Impervious surfaces (pavements, roofs, etc)					0.06 ac	98.00
DC Compositd CN (AMC 2)					98.00	
DCI - TC Calc						
Type	Description	Length	Slope	Coeff	Misc	TT
Sheet		0.00 ft	0.0%	5.0	0.00 in	5.00 min
Pervious TC						5.00 min

Record Id: cb8

Design Method	SBUH	Rainfall type		TYPE1A.RAC		
Hyd Intv	10.00 min	Peaking Factor		484.00		
Storm Duration	24.00 hrs	Abstraction Coeff		0.20		
Pervious Area	0.01 ac	DCIA		0.04 ac		
Pervious CN	86.00	DC CN		98.00		
Pervious TC	5.00 min	DC TC		5.00 min		
Pervious CN Calc						
Description					SubArea	Sub cn
Open spaces, lawns,parks (>75% grass)					0.01 ac	86.00
Pervious Compositd CN (AMC 2)					86.00	
Pervious TC Calc						
Type	Description	Length	Slope	Coeff	Misc	TT
Sheet		0.00 ft	0.0%	5.0	0.00 in	5.00 min

Pervious TC						5.00 min
DCI - CN Calc						
Description					SubArea	Sub cn
Impervious surfaces (pavements, roofs, etc)					0.04 ac	98.00
DC Composited CN (AMC 2)					98.00	
DCI - TC Calc						
Type	Description	Length	Slope	Coeff	Misc	TT
Sheet		0.00 ft	0.0%	5.0	0.00 in	5.00 min
Pervious TC						5.00 min

Record Id: cb9

Design Method	SBUH	Rainfall type	TYPE1A.RAC			
Hyd Intv	10.00 min	Peaking Factor	484.00			
Storm Duration	24.00 hrs	Abstraction Coeff	0.20			
Pervious Area	0.20 ac	DCIA	0.42 ac			
Pervious CN	86.00	DC CN	98.00			
Pervious TC	5.00 min	DC TC	5.00 min			
Pervious CN Calc						
Description					SubArea	Sub cn
Open spaces, lawns,parks (>75% grass)					0.20 ac	86.00
Pervious Composited CN (AMC 2)					86.00	
Pervious TC Calc						
Type	Description	Length	Slope	Coeff	Misc	TT
Sheet		0.00 ft	0.0%	5.0	0.00 in	5.00 min
Pervious TC						5.00 min
DCI - CN Calc						
Description					SubArea	Sub cn
Impervious surfaces (pavements, roofs, etc)					0.42 ac	98.00
DC Composited CN (AMC 2)					98.00	
DCI - TC Calc						
Type	Description	Length	Slope	Coeff	Misc	TT
Sheet		0.00 ft	0.0%	5.0	0.00 in	5.00 min
Pervious TC						5.00 min

Record Id: co1

Design Method	SBUH	Rainfall type	TYPE1A.RAC			
Hyd Intv	10.00 min	Peaking Factor	484.00			
Storm Duration	24.00 hrs	Abstraction Coeff	0.20			
Pervious Area	0.00 ac	DCIA	0.44 ac			
Pervious CN	0.00	DC CN	98.00			
Pervious TC	5.00 min	DC TC	5.00 min			
Pervious TC Calc						
Type	Description	Length	Slope	Coeff	Misc	TT
Sheet		0.00 ft	0.0%	5.0	0.00 in	5.00 min
Pervious TC						5.00 min
DCI - CN Calc						
Description					SubArea	Sub cn
Impervious surfaces (pavements, roofs, etc)					0.44 ac	98.00
DC Compositd CN (AMC 2)						98.00
DCI - TC Calc						
Type	Description	Length	Slope	Coeff	Misc	TT
Sheet		0.00 ft	0.0%	5.0	0.00 in	5.00 min
Pervious TC						5.00 min

Record Id: co2

Design Method	SBUH	Rainfall type	TYPE1A.RAC			
Hyd Intv	10.00 min	Peaking Factor	484.00			
Storm Duration	24.00 hrs	Abstraction Coeff	0.20			
Pervious Area	0.00 ac	DCIA	0.34 ac			
Pervious CN	0.00	DC CN	98.00			
Pervious TC	5.00 min	DC TC	5.00 min			
Pervious TC Calc						
Type	Description	Length	Slope	Coeff	Misc	TT
Sheet		0.00 ft	0.0%	5.0	0.00 in	5.00 min
Pervious TC						5.00 min
DCI - CN Calc						
Description					SubArea	Sub cn
Impervious surfaces (pavements, roofs, etc)					0.34 ac	98.00
DC Compositd CN (AMC 2)						98.00
DCI - TC Calc						

Type	Description	Length	Slope	Coeff	Misc	TT
Sheet		0.00 ft	0.0%	5.0	0.00 in	5.00 min
Pervious TC						5.00 min

Record Id: co3

Design Method	SBUH	Rainfall type	TYPE1A.RAC			
Hyd Intv	10.00 min	Peaking Factor	484.00			
Storm Duration	24.00 hrs	Abstraction Coeff	0.20			
Pervious Area	0.00 ac	DCIA	0.35 ac			
Pervious CN	0.00	DC CN	98.00			
Pervious TC	5.00 min	DC TC	5.00 min			
Pervious TC Calc						
Type	Description	Length	Slope	Coeff	Misc	TT
Sheet		0.00 ft	0.0%	5.0	0.00 in	5.00 min
Pervious TC						5.00 min
DCI - CN Calc						
Description					SubArea	Sub cn
Impervious surfaces (pavements, roofs, etc)					0.35 ac	98.00
DC Compositd CN (AMC 2)						98.00
DCI - TC Calc						
Type	Description	Length	Slope	Coeff	Misc	TT
Sheet		0.00 ft	0.0%	5.0	0.00 in	5.00 min
Pervious TC						5.00 min

Record Id: co5

Design Method	SBUH	Rainfall type	TYPE1A.RAC			
Hyd Intv	10.00 min	Peaking Factor	484.00			
Storm Duration	24.00 hrs	Abstraction Coeff	0.20			
Pervious Area	0.00 ac	DCIA	0.19 ac			
Pervious CN	0.00	DC CN	98.00			
Pervious TC	5.00 min	DC TC	5.00 min			
Pervious TC Calc						
Type	Description	Length	Slope	Coeff	Misc	TT
Sheet		0.00 ft	0.0%	5.0	0.00 in	5.00 min
Pervious TC						5.00 min

DCI - CN Calc						
Description					SubArea	Sub cn
Impervious surfaces (pavements, roofs, etc)					0.19 ac	98.00
DC Compositied CN (AMC 2)						98.00

DCI - TC Calc						
Type	Description	Length	Slope	Coeff	Misc	TT
Sheet		0.00 ft	0.0%	5.0	0.00 in	5.00 min
Pervious TC						5.00 min

Record Id: co6

Design Method	SBUH	Rainfall type	TYPE1A.RAC			
Hyd Intv	10.00 min	Peaking Factor	484.00			
Storm Duration	24.00 hrs	Abstraction Coeff	0.20			
Pervious Area	0.00 ac	DCIA	0.63 ac			
Pervious CN	0.00	DC CN	98.00			
Pervious TC	5.00 min	DC TC	5.00 min			

Pervious TC Calc						
Type	Description	Length	Slope	Coeff	Misc	TT
Sheet		0.00 ft	0.0%	5.0	0.00 in	5.00 min
Pervious TC						5.00 min

DCI - CN Calc						
Description					SubArea	Sub cn
Impervious surfaces (pavements, roofs, etc)					0.63 ac	98.00
DC Compositied CN (AMC 2)						98.00

DCI - TC Calc						
Type	Description	Length	Slope	Coeff	Misc	TT
Sheet		0.00 ft	0.0%	5.0	0.00 in	5.00 min
Pervious TC						5.00 min

Record Id: co9

Design Method	SBUH	Rainfall type	TYPE1A.RAC			
Hyd Intv	10.00 min	Peaking Factor	484.00			
Storm Duration	24.00 hrs	Abstraction Coeff	0.20			
Pervious Area	0.00 ac	DCIA	0.19 ac			
Pervious CN	0.00	DC CN	98.00			

Pervious TC	5.00 min	DC TC	5.00 min			
Pervious TC Calc						
Type	Description	Length	Slope	Coeff	Misc	TT
Sheet		0.00 ft	0.0%	5.0	0.00 in	5.00 min
Pervious TC						5.00 min
DCI - CN Calc						
Description					SubArea	Sub cn
Impervious surfaces (pavements, roofs, etc)					0.19 ac	98.00
DC Compositied CN (AMC 2)						98.00
DCI - TC Calc						
Type	Description	Length	Slope	Coeff	Misc	TT
Sheet		0.00 ft	0.0%	5.0	0.00 in	5.00 min
Pervious TC						5.00 min

Licensed to: Barghausen Consulting Engineers

SOILS REPORT

GEOTECHNICAL REPORT

**Wesley Homes Puyallup
39th Avenue SE
Puyallup, Washington**

Project No. T-5915-3

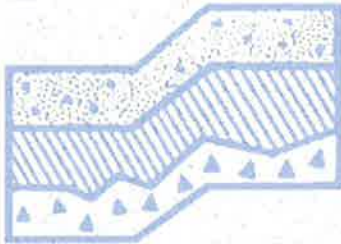

Terra Associates, Inc.

Prepared for:

**Wesley Homes
Des Moines, Washington**

**October 28, 2015
Revised November 14, 2016**

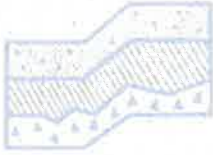

TERRA ASSOCIATES, Inc.

Consultants in Geotechnical Engineering, Geology
and
Environmental Earth Sciences

October 28, 2015
Revised November 14, 2016
Project No. T-5915-3

Mr. Kevin Anderson
Wesley Homes
815 South 216th Street
Des Moines, Washington 98198

Subject: Geotechnical Report
Wesley Homes Puyallup
39th Avenue SE
Puyallup, Washington

Dear Mr. Anderson:

As requested, we have conducted a geotechnical engineering study for the subject project. The attached report presents our findings and recommendations for the geotechnical aspects of project design and construction.

Our field exploration indicates the soil conditions generally consist of 2 to 18 inches of organic topsoil overlying glacial drift deposits composed of a varying mixture of silty sand, sand, gravel, and silt. In general, the soils were found in a medium dense to dense condition. The exception to this general condition was observed in Test Pit TP-103 where we observed approximately 13.5 feet of organic fill material overlying the native soils. Similar fill material was also observed in Test Pits TP-11 and TP-12 by GeoEngineers (2003) and Test Pit TP-8 by Terra Associates, Inc. (2006).

These fill soils observed are not suitable for building support and should be removed and replaced with new structural fill. Alternatively, the northern buildings may be supported on deep foundations such as pipe piles or on ground improved by installation of Geopiers.

In our opinion, the native soils on the site will be suitable for support of the proposed development provided the recommendations presented in this report are incorporated into project design and construction.

Mr. Kevin Anderson
October 28, 2015
Revised November 14, 2016

We trust the information presented in this report is sufficient for your current needs. If you have any questions or require additional information, please call.

Sincerely yours,
TERRA ASSOCIATES, INC.



Carolyn S. Decker, P.E.
Project Engineer



Theodore J. Schepper, P.E.
President

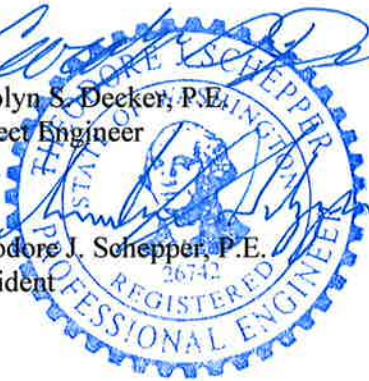

11-14-16

TABLE OF CONTENTS

	<u>Page No.</u>
1.0 Project Description.....	1
2.0 Scope of Work	1
3.0 Site Conditions.....	2
3.1 Surface	2
3.2 Soils	2
3.3 Groundwater	3
4.0 Geologic Hazards.....	3
4.1 Seismic Considerations	3
4.2 Erosion	4
4.3 Landslide Hazard	5
5.0 Discussion and Recommendations.....	5
5.1 General.....	5
5.2 Site Preparation and Grading	6
5.3 Excavations.....	7
5.4 Slopes and Embankments	8
5.5 Foundations.....	8
5.6 Slab-on-Grade Construction	10
5.7 Lateral Earth Pressure on Below-Grade Walls	10
5.8 Stormwater Detention Pond.....	11
5.9 Drainage.....	11
5.10 Utilities.....	12
5.11 Pavements	12
6.0 Additional Services.....	13
7.0 Limitations	13

Figures

Vicinity Map.....	Figure 1
Exploration Location Plan	Figure 2
Typical Slope Key and Bench Detail.....	Figure 3
Typical Wall Drainage Detail.....	Figure 4

Appendices

Field Exploration and Laboratory Testing.....	Appendix A
Previous Test Pit Logs.....	Appendix B

Geotechnical Report Wesley Homes Puyallup 39th Avenue SE Puyallup, Washington

1.0 PROJECT DESCRIPTION

The project consists of developing the approximately 14-acre site with a senior housing complex. The complex will include a multi-story building, two brownstone buildings, a stormwater detention pond, and associated access and utility improvements. Based on the grading and storm drainage plan prepared by Barghausen Consulting Engineers dated April 6, 2016, grading to achieve building lot and roadway grades will consist of cuts and fills from 1 to 13 feet. Vertical grade transitions will be supported by retaining walls.

Stormwater will be collected and routed to a detention pond located in the southwest portion of the site. The pond will be formed by a combination of excavation below current site grade, construction of a fill containment berm along the northwest perimeter, and construction of a retaining wall along the east perimeter. The excavation required to achieve the floor elevation of 447.0 will extend 11 to 15 feet below current site grades. The fill depth required to achieve the berm crest elevation of 459.0 will range from 6 to 9 feet.

We expect the multi-story building and brownstone buildings to be wood-framed with slab-on-grade floors producing moderate foundation loads with bearing wall and isolated column loads ranging from about 4 to 6 kips per foot and 200 to 400 kips.

The recommendations in the following sections of this report are based on our understanding of the preceding design features. We should review design drawings as they become available to verify that our recommendations have been properly interpreted and to supplement them, if required.

2.0 SCOPE OF WORK

Our work was completed in accordance with our proposal dated June 1, 2015. Accordingly, on October 13, 2015, we excavated 12 test pits to a maximum depth of 15 feet below existing surface grades. Using the information obtained from our recent subsurface exploration, previous subsurface exploration, and laboratory testing, we performed analyses to develop geotechnical recommendations for project design and construction. Specifically, this report addresses the following:

- Soil and groundwater conditions
- Seismic Criteria per 2015 International Building Code (IBC)
- Geologic Hazards per City of Puyallup Municipal Code
- Site preparation and grading
- Slopes and embankments
- Excavations

- Foundations
- Slab-on-grade floors
- Stormwater detention pond
- Low Impact Development (LID) Methods
- Lateral earth pressure parameters for wall design
- Drainage
- Utilities
- Pavements

It should be noted that recommendations outlined in this report regarding drainage are associated with soil strength, design earth pressures, erosion, and stability. Design and performance issues with respect to moisture as it relates to the structure environment are beyond Terra Associates' purview. A building envelope specialist or contractor should be consulted to address these issues, as needed.

3.0 SITE CONDITIONS

3.1 Surface

The project site is located on the north side of 37th Avenue SE Street approximately 80 feet west of the intersection with 10th Street SE in Puyallup, Washington. The approximate location of the site is shown on the Vicinity Map, Figure 1.

The site is irregular in plan dimension measuring approximately 370 by 1,270 feet. An electrical substation exists east of the property. The majority of the project site slopes gently down towards the west. Overall relief across the site is about 50 feet. The western site margin is bounded by a west-facing slope with approximately 20 feet of local relief with a gradient of about 14 to 30 percent. The site is covered with large to medium-sized Evergreen and deciduous trees and moderate growth of underbrush.

3.2 Soils

In general, the soil conditions observed in the recent test pits consisted of 2 to 18 inches of organic topsoil overlying glacial drift deposits composed of varying mixtures of silty sand, sand, gravel, and silt. In general, the soils were found in a medium dense to dense condition. The exception to this general condition was observed in Test Pit TP-103 where we observed approximately 13.5 feet of organic fill material overlying the native soils. Similar fill material was also observed in Test Pits TP-11 and TP-12 by GeoEngineers (2003) and Test Pit TP-8 by Terra Associates, Inc. (2006).

The *Geologic Map of the South Half of The Tacoma Quadrangle, Washington*, by Timothy J. Walsh, dated 1987 maps the soils as Vashon glacial drift (Vdv). The Vashon glacial drift is described as recessional and interglacial stratified outwash sands and gravels, locally containing silts and clays. Native soil conditions we observed in our test pits are consistent with this mapped geology.

The preceding discussion is intended as a general review of the soil conditions encountered. A more detailed description of the subsurface conditions encountered is presented on the Test Pit Logs in Appendix A. The approximate test pit locations are shown on Figure 2. Figure 2 also shows the location of previous test pits excavated by GeoEngineers and Terra Associates, Inc. Previous test pit logs prepared by GeoEngineers and Terra Associates, Inc. are included in Appendix B.

3.3 Groundwater

We observed groundwater seepage in Test Pits TP-107, TP-109, and TP-110 between 7 and 11 feet below current site grades which equates to approximately elevation 443 to 445 feet relative to site elevations. The groundwater was observed flowing from a recessional gravel outwash layer. Previous site exploration test pits excavated by GeoEngineers in March 2003 encountered similar groundwater flows from this gravel layer at depths of five to nine feet below site grades. Based on the location of the test pits and elevation of the groundwater, it appears that the groundwater observed represents a localized shallow groundwater table residing in the gravel outwash.

Although we did not observe groundwater in the other test pits we did observe mottled or iron staining of the upper few feet of many of the soil layers indicating perched shallow groundwater tables likely develop during the normally wet winter months.

4.0 GEOLOGIC HAZARDS

4.1 Seismic Considerations

Section 21.06.210 (113) of the City of Puyallup Municipal Code (PMC) defines Seismic hazard areas as “areas that are subject to severe risk of damage as a result of earthquake-induced ground shaking, slope failure, settlement, or soil liquefaction.”

Liquefaction is a phenomenon where there is a reduction or complete loss of soil strength due to an increase in water pressure induced by vibrations. Liquefaction mainly affects geologically recent deposits of fine-grained sand that are below the groundwater table. Soils of this nature derive their strength from intergranular friction. The generated water pressure or pore pressure essentially separates the soil grains and eliminates this intergranular friction; thus, eliminating the soil’s strength.

Based on the soil and groundwater conditions we observed, it is our opinion that there is minimal risk for liquefaction related impacts to occur at this site during an earthquake.

Based on soil conditions observed in the test borings and our knowledge of the area geology, per Chapter 16 of the 2015 International Building Code (IBC), site class “C” should be used in structural design. Based on this site class, in accordance with the 2015 IBC, the following parameters should be used in computing seismic forces:

Seismic Design Parameters (IBC 2015)

Spectral response acceleration (Short Period), S_{Ms}	1.244
Spectral response acceleration (1 – Second Period), S_{M1}	0.632
Five percent damped .2 second period, S_{Ds}	0.829
Five percent damped 1.0 second period, S_{D1}	0.421

These values were determined using the latitude/longitude coordinates 47.156499/-122.283487 and the United States Geological Survey (USGS) Ground Motion Parameter Calculator accessed on November 9, 2016 at the web site <http://earthquake.usgs.gov/designmaps/us/application.php>.

4.2 Erosion

Section 21.06.210 (40) of the PMC defines Erosion hazard areas as “lands or areas underlain by soils identified by the U.S. Department of Agriculture Natural Resource Conservation Service (NRCS) as having “severe” or “very severe” erosion hazards. These include, but are not limited to, the following group of soils when they occur on slopes of 15 percent or greater: Alderwood gravelly sandy loam, Indianola gravelly loam, Kapowsin gravelly loam, Kitsap silt loam (KpD), and Xerochrepts.”

The soils observed on-site are classified as Everett gravelly sand loam 0 to 6 percent slopes and Neilton gravelly loamy sand, 8 to 25 percent slopes by the United States Department of Agriculture Natural Resources Conservation Service (NRCS), formerly the Soil Conservation Service. With the existing slope gradients, these soils will have a slight to severe potential for erosion when exposed. Therefore, the site is an erosion hazard area as defined by the PMC.

Implementation of temporary and permanent Best Management Practices (BMPs) for preventing and controlling erosion will be required and will mitigate the erosion hazard. As a minimum, we recommend implementing the following erosion and sediment control BMPs prior to, during, and immediately following construction activities at the site.

Prevention

- Limit site clearing and grading activities to the relatively dry months (typically May through September).
- Limit disturbance to areas where construction is imminent.
- Locate temporary stockpiles of excavated soils no closer than ten feet from the crest of slopes.
- Provide temporary cover for cut slopes and soil stockpiles during periods of inactivity. Temporary cover may consist of durable plastic sheeting that is securely anchored to the ground surface or straw mulch.
- Establish permanent cover over exposed areas that will not be disturbed for a period of 30 days or more by seeding, in conjunction with a mulch cover or appropriate hydroseeding.

Containment

- Install a silt fence along site margins and downslope of areas that will be disturbed. The silt fence should be in place before clearing and grading is initiated.
- Intercept surface water flow and route the flow away from the slope to a stabilized discharge point. Surface water must not discharge at the top or onto the face of the steep slope.
- Provide on-site sediment retention for collected runoff.

The contractor should perform daily review and maintenance of all erosion and sedimentation control measures at the site.

4.3 Landslide Hazard

Section 21.06.210 (81) of the PMC defines Landslide Hazard areas as “areas that, due to a combination of site conditions like slope inclination and relative soil permeability are susceptible to landsliding.”

With the soil conditions and existing slope gradients observed at the site, in our opinion the site does not contain any landslide hazard areas as defined by the PMC.

5.0 DISCUSSION AND RECOMMENDATIONS

5.1 General

Based on our study, from a geotechnical engineering perspective, the site is suitable for the proposed development. The competent inorganic native soils would provide suitable support for conventional spread footing foundations. Alternatively, if required by desired final building elevations, structural fill placed and compacted above these native soils can be used to support the building foundations. Floor slabs and pavements can be similarly supported.

The existing fill soils observed to depths of 15 feet in the northern area of the site will not be suitable for building support. These existing fills will either need to be removed and replaced with new structural fill or the building foundations and floor supported on piles driven or drilled through the fill into the underlying competent native soils. The lateral extent of the undocumented fill will need to be determined in the field during grading.

Some of the native soils encountered at the site contain a significant amount of fines and will be difficult to compact as structural fill when too wet. The ability to use native silty soils from site excavations as structural fill will depend on its moisture content and the prevailing weather conditions at the time of construction. If grading activities will take place during the winter season, the owner should be prepared to import free-draining granular material for use as structural fill and backfill. The cleaner gravelly sand and sand layers would be suitable for use as structural fill under most weather conditions. The existing organic fill material would not be suitable for reuse as structural fill.

Detailed recommendations regarding the above issues and other geotechnical design considerations are provided in the following sections. These recommendations should be incorporated into the final design drawings and construction specifications.

5.2 Site Preparation and Grading

To prepare the site for construction, existing surface vegetation and other deleterious materials should be stripped and removed. Based on conditions observed at the test pits, we would estimate that surface stripping depths of 2 to 18 inches will be required to remove site vegetation and associated near-surface organic debris. Vegetation debris from clearing operations should be removed from the site. Organic topsoil will not be suitable for use as structural fill, but may be used for limited depths in nonstructural areas.

If the northern building in the vicinity of Terra Test Pits TP-103 and TP-8 and GeoEngineers Test Pits TP-11 and TP-12 are not supported on piles, the existing fill will need to be removed and replaced with structural fill for building support. Excavations to remove the existing fill will, based on the test pits, extend to depths of at least 15 feet below current site grades. The lateral extent of the undocumented fill material will need to be determined in the field during grading.

Once clearing and stripping operations are complete, cut and fill operations can be initiated to establish desired grades. Prior to placing fill, all exposed bearing surfaces should be observed by a representative of Terra Associates to verify soil conditions are as expected and suitable for support of new fill. Our representative may request a proofroll using heavy rubber-tired equipment to determine if any isolated soft and yielding areas are present. If excessively yielding areas are observed, and they cannot be stabilized in place by compaction, the affected soils should be excavated and removed to firm bearing and grade restored with new structural fill. Beneath embankment fills or roadway subgrade if the depth of excavation to remove unstable soils is excessive, the use of geotextile fabrics, such as Mirafi 500X, or an equivalent fabric, can be used in conjunction with clean granular structural fill. Our experience has shown that, in general, a minimum of 18 inches of a clean, granular structural fill placed and compacted over the geotextile fabric should establish a stable bearing surface.

Some of the native soils encountered at the site contain a significant amount of fines and will be difficult to compact as structural fill when too wet. The ability to use native silty soils from site excavations as structural fill will depend on its moisture content and the prevailing weather conditions at the time of construction. If grading activities will take place during the winter season, the owner should be prepared to import free-draining granular material for use as structural fill and backfill. The cleaner sand and gravel layers would be suitable for use as structural fill under most weather conditions.

If imported fill is needed for site grading or subgrade preparation, we recommend that the fill consist of inorganic granular soil meeting the following gradation:

U.S. Sieve Size	Percent Passing
3 inches	100
No. 4	75 maximum
No. 200	5 maximum*

*Based on the 3/4-inch fraction.

Prior to use, Terra Associates, Inc. should examine and test all materials imported to the site for use as structural fill.

Structural fill should be placed in uniform loose layers not exceeding 12 inches and compacted to a minimum of 95 percent of the soil's maximum dry density, as determined by American Society for Testing and Materials (ASTM) Test Designation D-698 (Standard Proctor). The moisture content of the soil at the time of compaction should be within two percent of its optimum, as determined by this ASTM standard. In nonstructural areas the degree of compaction can be reduced to 90 percent.

5.3 Excavations

All excavations at the site associated with confined spaces, such as utility trenches and lower building levels, must be completed in accordance with local, state, or federal requirements. Based on current Washington State Industrial Safety and Health Administration (WISHA) regulations, the upper loose uncontrolled fill and medium dense to dense native soils at the site would be classified as Type C soils. The deeper very dense native soils would be classified as Type A soils.

Accordingly, temporary excavations in Type C soils should have their slopes laid back at an inclination of 1.5:1 (Horizontal:Vertical) or flatter, from the toe to the crest of the slope. Side slopes in Type A soils can be laid back at a slope inclination of 0.75:1 or flatter. For temporary excavation slopes less than 8 feet in height in Type A soils, the lower 3.5 feet can be cut to a vertical condition, with a 0.75:1 slope graded above. For temporary excavation slopes greater than 8 feet in height up to a maximum height of 12 feet, the slope above the 3.5-foot vertical portion will need to be laid back at a minimum slope inclination of 1:1. No vertical cut with a backslope immediately above is allowed for excavation depths that exceed 12 feet. In this case, a four-foot vertical cut with an equivalent horizontal bench to the cut slope toe is required. All exposed temporary slope faces that will remain open for an extended period of time should be covered with a durable reinforced plastic membrane during construction to prevent slope raveling and rutting during periods of precipitation.

Site exploration indicates the presence of a localized shallow groundwater table contained in the gravel outwash layer at depths of 5 to 11 feet below current site grades. Also perched groundwater development can be expected at the site during the winter season. The contractor should be prepared to dewater site excavations as needed to maintain stability and relatively dry working conditions. Dewatering using conventional sump pumps along with collector trenches at the excavation base or perimeter cut off drains to capture and control seepage before it enters the excavation will need to be considered.

The above information is provided solely for the benefit of the owner and other design consultants, and should not be construed to imply that Terra Associates, Inc. assumes responsibility for job site safety. Job site safety is the sole responsibility of the project contractor.

5.4 Slopes and Embankments

All permanent cut and fill slopes should be graded with a finished inclination of no greater than 2:1 (Horizontal:Vertical). Upon completion of grading, the slope face should be appropriately vegetated or provided with other physical means to guard against erosion. Final grades at the top of the slope must promote surface drainage away from the slope crest. Water must not be allowed to flow uncontrolled over the slope face. If surface runoff must be directed towards the slope, the runoff should be controlled at the top of the slope, piped in a closed conduit installed on the slope face, and taken to an appropriate point of discharge beyond the toe.

All fill placed for embankment construction should meet the structural fill requirements in Section 5.2 of this report. In addition, if the new fills will be placed over existing slopes of 20 percent or greater, the structural fill should be keyed and benched into competent native slope soils. Figure 3 presents a typical slope key and bench configuration. At minimum, a toe drain should be installed in the key cut as shown on Figure 3. Depending on seepage conditions, drains may also be required along individual benches excavated on the slope face especially along the pond slopes. The need for drains along the upper benches will be best determined in the field at the time of construction.

5.5 Foundations

Spread Footings

The buildings may be supported on conventional, isolated, or continuous spread footing foundations bearing on the competent undisturbed native soils or structural fill placed on undisturbed competent native soils. Spread footing foundations bearing on undisturbed subgrade composed of the native soils and compacted structural fill can be designed for a net allowable bearing capacity 3,000 pounds per square foot (psf). For short-term loads, such as wind and seismic, a one-third increase in the allowable bearing capacity may be used. For the structural loading expected, we estimate total settlement of isolated spread footings will be one-inch or less, with differential settlement of one-half inch and less.

For designing foundations to resist lateral loads, a base friction coefficient of 0.35 can be used. Passive earth pressures acting on the side of the footing can also be considered. We recommend calculating this lateral resistance using an equivalent fluid weight of 350 pcf. We recommend not including the upper 12 inches of soil in this computation because they can be affected by weather or disturbed by future grading activity. This value assumes the foundation will be constructed neat against competent fill soil or backfilled with structural fill. The recommended lateral resistance value includes a safety factor of 1.5.

The soils exposed at foundation levels for the large multi-unit buildings should be observed by Terra Associates, Inc. If loose or medium stiff silts are present at planned footing grades, these silts should be overexcavated and be replaced with structural fill or as an alternative, the foundations may be stepped down to bear on the underlying dense glacially consolidated soils.

The following sections address foundation options for the northern buildings underlain by loose fills.

Steel Pipe Piles

If excavation and replacement of existing fills for the northern buildings is determined to be uneconomical or unfeasible, a suitable alternative for foundation support is to transfer building loads through the uncontrolled fill to the underlying very dense or hard bearing strata using four-inch diameter steel pipe piles. The pipe piles should be driven to refusal using a minimum 850 foot-pound impact hammer. Refusal is defined as less than one-inch of pile penetration during 15 seconds of continuous driving.

Based on data from the test pits, we anticipate pile tip elevations will range from 15 to 20 feet below existing grades. Pipe pile installation may encounter some obstructions, such as wood debris and roots. If an obstruction is encountered during driving, the pile location should be excavated, the obstruction removed, and the area then refilled to grade before re-driving. Alternatively, flexibility in pile location can be included in the design to allow for relocating the pile a short distance in an attempt to avoid the obstruction.

Four-inch diameter steel pipe piles driven to refusal will develop an allowable axial capacity of ten tons per pile. For resistance to lateral loading, a lateral pile capacity of one-fourth of a ton can be used for vertically-placed piles. Pipe piles may be battered to increase their ability to resist lateral loads. We expect pile settlements would not exceed one-fourth of an inch.

Ground Improvement

As an alternative to piles, consideration can be given to using ground other improvement techniques to establish suitable support for conventional spread footing designs. Methods that could be considered include vibrated stone columns or Geopiers (aggregate rammed piers). Both of these methods create highly densified columns of graded aggregate that would extend through the upper softer soils a short depth into the underlying dense sands. Because of the methods used to construct the columns some improvement of the adjacent soils is also realized. Once constructed, conventional spread footing foundations can be designed to bear immediately above the stone column/Geopier locations.

These ground improvement techniques are typically completed on a design/build approach with both design and construction completed by a specialty contractor. We can assist in contracting and selecting the specialty contractor, if desired.

5.6 Slab-on-Grade Construction

Slab-on-grade may be supported on competent undisturbed bearing surfaces consisting of the native dense drift soils or structural fill placed above competent native soils. If the existing fill is not removed from below the northern buildings the floors should also be structurally supported on piles.

Immediately below the floor slab, we recommend placing a four-inch thick capillary break layer composed of clean, coarse sand or fine gravel that has less than three percent passing the No. 200 sieve. This material will reduce the potential for upward capillary movement of water through the underlying soil and subsequent wetting of the floor slab.

The capillary break layer will not prevent moisture intrusion through the slab caused by water vapor transmission. Where moisture by vapor transmission is undesirable, such as covered floor areas, a common practice is to place a durable plastic membrane on the capillary break layer and then cover the membrane with a layer of clean sand or fine gravel to protect it from damage during construction, and aid in uniform curing of the concrete slab. It should be noted that if the sand or gravel layer overlying the membrane is saturated prior to pouring the slab, it will be ineffective in assisting uniform curing of the slab, and can actually serve as a water supply for moisture seeping through the slab and affecting floor coverings. Therefore, in our opinion, covering the membrane with a layer of sand or gravel should be avoided if floor slab construction occurs during the wet winter months and the layer cannot be effectively drained. We recommend floor designers and contractors refer to the 2003 American Concrete Institute (ACI) Manual of Concrete Practice, Part 2, 302.1R-96, for further information regarding vapor barrier installation below slab-on-grade floors.

5.7 Lateral Earth Pressure on Below-Grade Building Walls

The magnitude of earth pressure development on below-grade walls will partly depend on the quality of the wall backfill. We recommend placing and compacting wall backfill as structural fill as described in Section 5.2 of this report. To guard against hydrostatic pressure development, wall drainage must also be installed. A typical recommended wall drainage detail is shown on Figure 4.

With wall backfill placed and compacted as recommended, and drainage properly installed, we recommend designing unrestrained walls for an active earth pressure equivalent to a fluid weighing 35 pounds per cubic foot (pcf). For restrained walls, an additional uniform load of 100 psf should be added to the 35 pcf. To account for typical traffic surcharge loading, the walls can be designed for an additional imaginary height of two feet (two-foot soil surcharge). For evaluation of wall performance under seismic loading, a uniform pressure equivalent to $8H$ psf, where H is the height of the below-grade portion of the wall should be applied in addition to the static lateral earth pressure. These values assume a horizontal backfill condition and that no other surcharge loading, sloping embankments, or adjacent buildings will act on the wall. If such conditions exist, then the imposed loading must be included in the wall design. Friction at the base of foundations and passive earth pressure will provide resistance to these lateral loads. Values for these parameters are provided in Section 5.5 of this report.

5.8 Stormwater Detention Pond

As mentioned above, a stormwater pond is planned for the site. The proposed pond floor is between 11 and 15 feet below existing site grades and is formed by a combination of excavation, fill containment berm construction, and wall construction. The fill depths for the berm construction are between six and nine feet. Fill used to form containment berms for the detention ponds should consist of native silty sand with gravel placed and compacted as structural fill. Interior pond slopes below the stored water level should be graded at 3:1 with exterior pond slopes at 2:1.

Our field exploration indicates that the soils in the area of the pond consist of dense gravel with silt and sand. Heavy groundwater flow was observed near elevations 443 to 445 feet in the test pits located in the larger pond area which is currently below the proposed bottom of pond elevation of 447 feet. This groundwater elevation would be expected to rise during the normally wet winter season. While the soils encountered at this pond site exhibit permeability characteristics that would be suitable for infiltration considerations the elevated groundwater table would preclude designing the pond as a retention facility. However, if there is a dead storage water quality component in the pond design, lining the pond to prevent infiltration losses of the dead storage component will need to be considered.

5.9 Drainage

Surface

Final exterior grades should promote free and positive drainage away from the site at all times. Water must not be allowed to pond or collect adjacent to foundations or within the immediate building area. We recommend providing a positive drainage gradient away from the building perimeter. If this gradient cannot be provided, surface water should be collected adjacent to the structures and disposed to appropriate storm facilities.

Surface water must not be allowed to flow uncontrolled over the crest of the site slopes and embankments. Surface water should be directed away from the slope crests to a point of collection and controlled discharge. If site grades do not allow for directing surface water away from the slopes, then water should be collected and tightlined down the slope face in a controlled manner.

Subsurface

We recommend installing perimeter foundation drains adjacent to shallow foundations. The drains can be laid to grade at an invert elevation equivalent to the bottom of footing grade. The drains can consist of four-inch diameter perforated PVC pipe that is enveloped in washed pea gravel-sized drainage aggregate. The aggregate should extend six inches above and to the sides of the pipe. Roof and foundation drains should be tightlined separately to the storm drains. All drains should be provided with cleanouts at easily accessible locations.

Infiltration

The drift soils composed of silty sand with gravel, silt, and sandy silt characteristically exhibits low permeability and would not be a suitable receptor soil for discharge of development stormwater using infiltration/retention facilities. While there are deposits of cleaner outwash soils also present within the drift deposits their random distribution and limited thickness would preclude designing and using infiltration systems, in our opinion. Conventional stormwater detention with controlled release to the drainage basin should be used to manage development stormwater.

5.10 Utilities

Utility pipes should be bedded and backfilled in accordance with American Public Works Association (APWA) specifications. For site utilities within city rights of way, bedding and backfill should be completed in accordance with City of Puyallup specifications. At minimum, trench backfill should be placed and compacted as structural fill, as described in the Section 5.2 of this report. As noted, soils excavated on-site should be suitable for use as backfill material during dry weather conditions. However, the contractor should be prepared to moisture condition the soils to facilitate proper compaction, as necessary and import suitable material during the wet winter months.

5.11 Pavements

The pavement design section is dependent upon the supporting capability of the subgrade soils and the traffic conditions to which it will be subjected. All subgrade should be prepared in accordance with the recommendations in Section 5.2 of this report. For traffic consisting mainly of light passenger and commercial vehicles with only occasional heavy traffic, and with a stable subgrade prepared as recommended, we recommend the following pavement sections:

- Two inches of Hot Mix Asphalt (HMA) over four inches of crushed rock base (CRB)
- Four inches full depth HMA

The paving materials used should conform to the current Washington State Department of Transportation (WSDOT) specifications for HMA and CRB surfacing.

Long-term pavement performance will depend on surface drainage. A poorly-drained pavement section will be subject to premature failure as a result of surface water infiltrating into the subgrade soils and reducing their supporting capability. For optimum pavement performance, we recommend surface drainage gradients of at least two percent. Some degree of longitudinal and transverse cracking of the pavement surface should be expected over time. Regular maintenance should be planned to seal cracks when they occur.

6.0 ADDITIONAL SERVICES

Terra Associates, Inc. should review the final design and specifications in order to verify that earthwork and foundation recommendations have been properly interpreted and implemented in project design. We should also provide geotechnical services during construction in order to observe compliance with the design concepts, specifications, and recommendations. This will allow for design changes if subsurface conditions differ from those anticipated prior to the start of construction.

7.0 LIMITATIONS

This report is the property of Terra Associates, Inc. and was prepared in accordance with generally accepted geotechnical engineering practices. This report is intended for specific application to the Wesley Homes Puyallup project and for the exclusive use of Wesley Homes and their authorized representatives. No other warranty, expressed or implied, is made.

The analyses and recommendations presented in this report are based upon data obtained from the test pits excavated on-site. Variations in soil conditions can occur, the nature and extent of which may not become evident until construction. If variations appear evident, Terra Associates, Inc. should be requested to reevaluate the recommendations in this report prior to proceeding with construction.

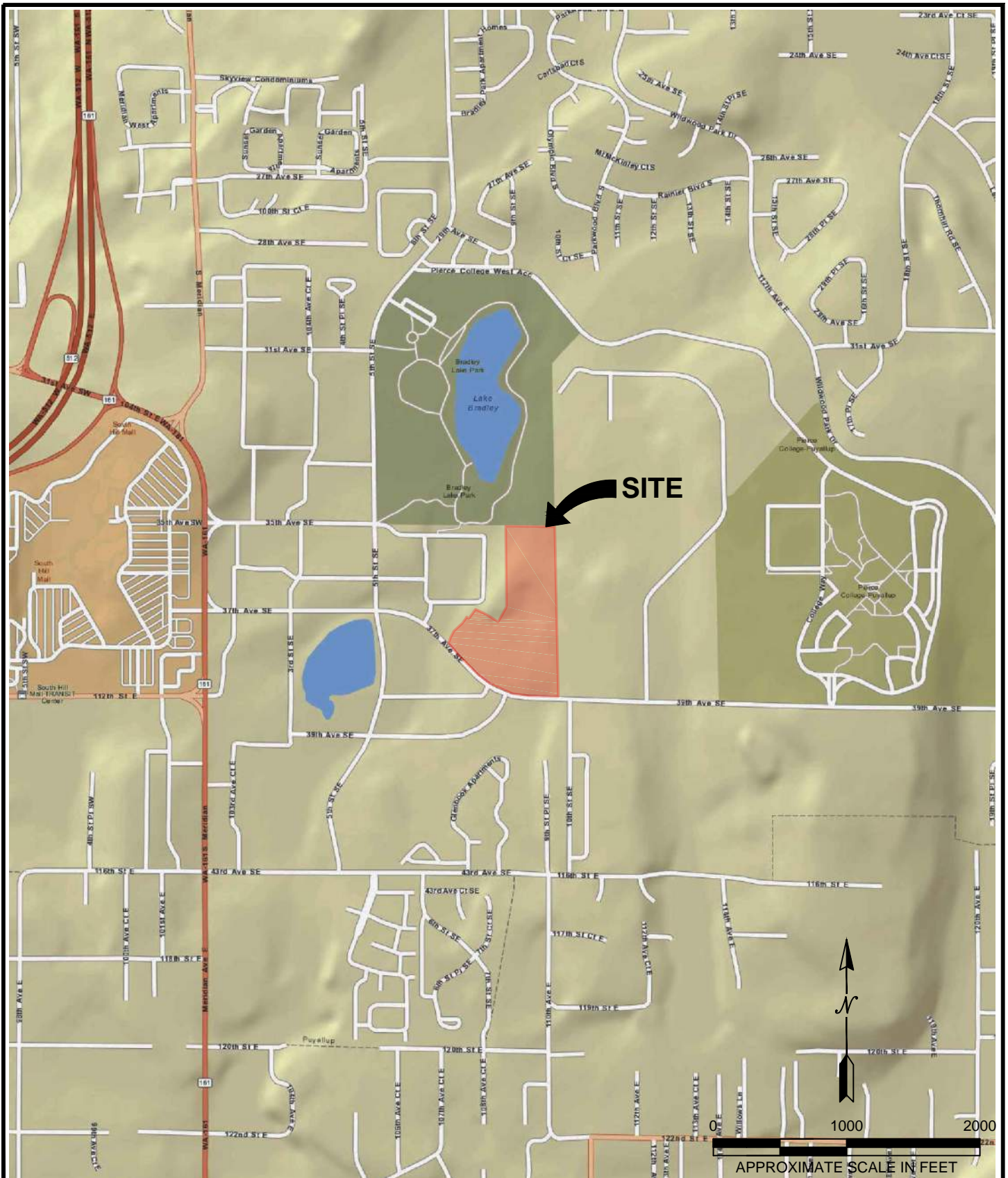

REFERENCE: <http://www.wsdot.wa.gov/data/tools/geoportal/>

ACCESSED 10/27/15

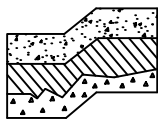

Terra Associates, Inc.
 Consultants in Geotechnical Engineering
 Geology and
 Environmental Earth Sciences

VICINITY MAP
 WESLEY HOMES PUYALLUP
 PUYALLUP, WASHINGTON

Proj. No.T-5915-3

Date NOV 2016

Figure 1

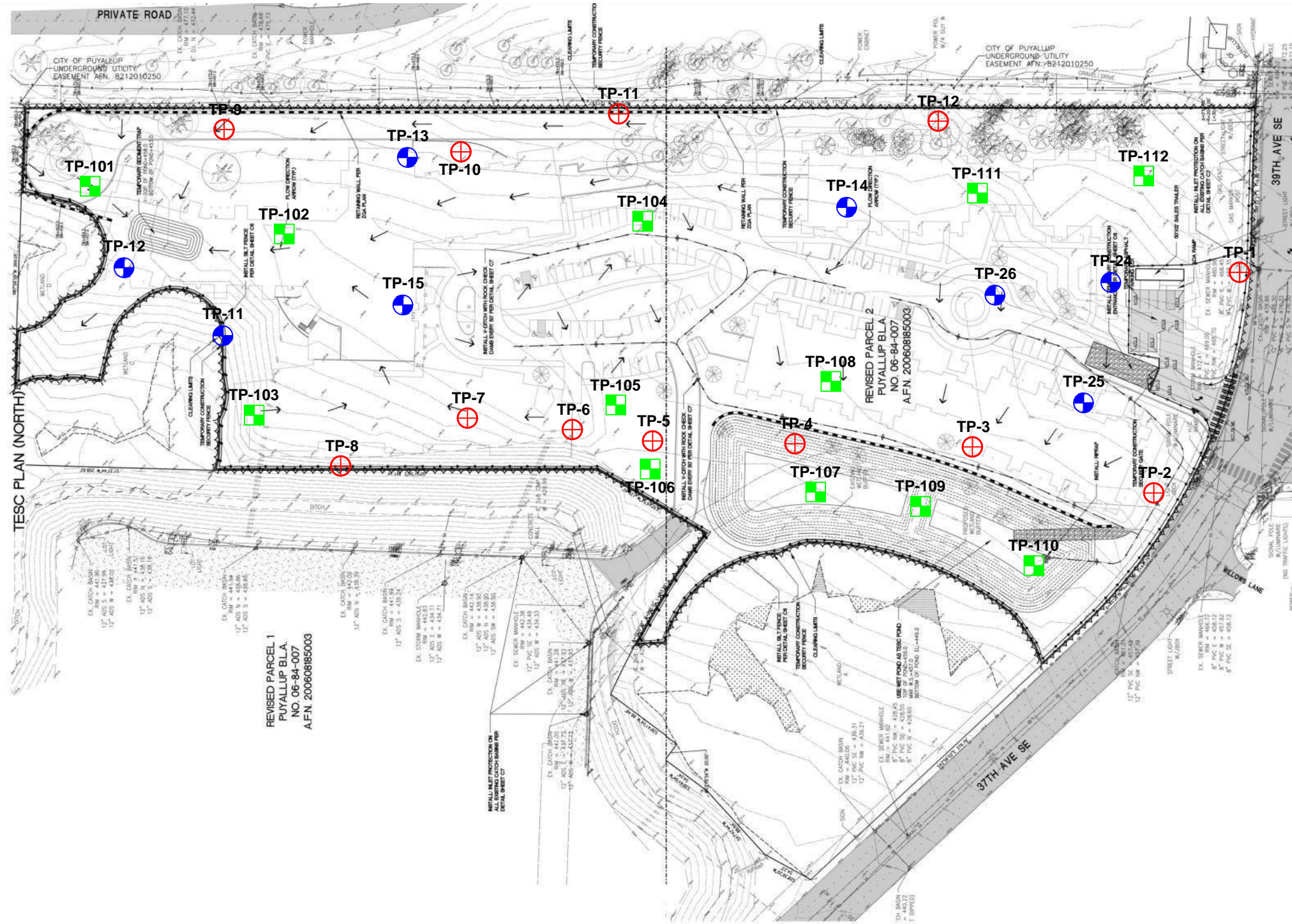



NOTE:

THIS SITE PLAN IS SCHEMATIC. ALL LOCATIONS AND DIMENSIONS ARE APPROXIMATE. IT IS INTENDED FOR REFERENCE ONLY AND SHOULD NOT BE USED FOR DESIGN OR CONSTRUCTION PURPOSES.

REFERENCE: SITE PLAN PROVIDED BY BARGHAUSEN.

LEGEND:

-  APPROXIMATE TEST PIT LOCATION (TERRA 2015)
-  APPROXIMATE TEST PIT LOCATION (GEO-ENGINEERS 2003)
-  APPROXIMATE TEST PIT LOCATION (TERRA ASSOCIATES 2006)

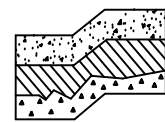

Terra Associates, Inc.
 Consultants in Geotechnical Engineering
 Geology and
 Environmental Earth Sciences

**EXPLORATION LOCATION PLAN
 WESLEY HOMES PUYALLUP
 PUYALLUP, WASHINGTON**

Proj. No. T-5915-3

Date NOV 2016

Figure 2

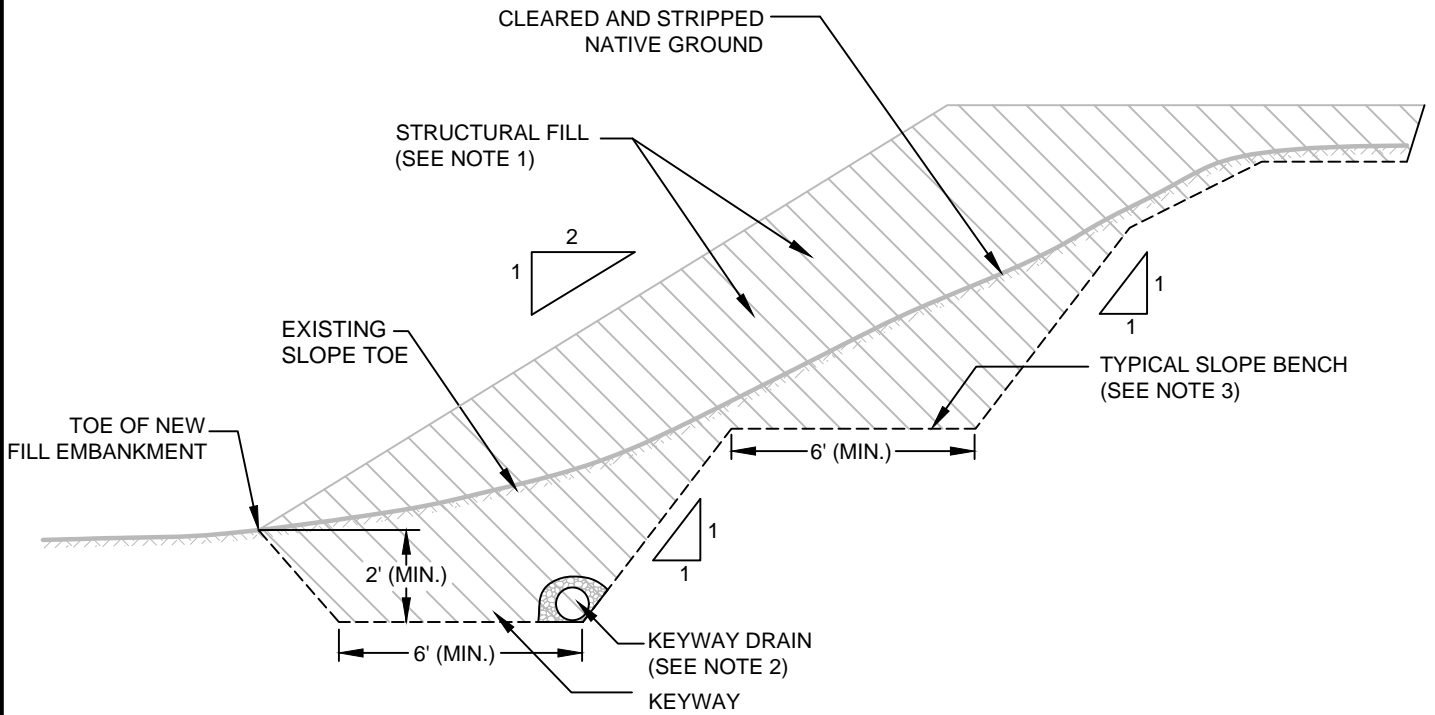

NOT TO SCALE

NOTES:

- 1) STRUCTURAL FILL SHALL BE COMPACTED TO A MINIMUM OF 95% OF ASTM D 698 MAXIMUM DRY DENSITY VALUE.
- 2) DRAINS SHALL CONSIST OF 6" DIA. PERFORATED PVC PIPE ENVELOPED IN 1 cu ft OF 3/4" WASHED GRAVEL. DRAIN PIPE SHALL BE DIRECTED TO THE STORM DRAIN SYSTEM OR APPROVED POINT OF DISCHARGE.
- 3) ADDITIONAL BENCHES AND BENCH DRAINS MAY BE REQUIRED BASED ON FIELD EVALUATION BY THE GEOTECHNICAL ENGINEER.

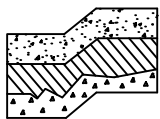

Terra Associates, Inc.
 Consultants in Geotechnical Engineering
 Geology and
 Environmental Earth Sciences

**TYPICAL SLOPE KEY AND BENCH DETAIL
 WESLEY HOMES PUYALLUP
 PUYALLUP, WASHINGTON**

Proj. No.T-5915-3

Date NOV 2016

Figure 3

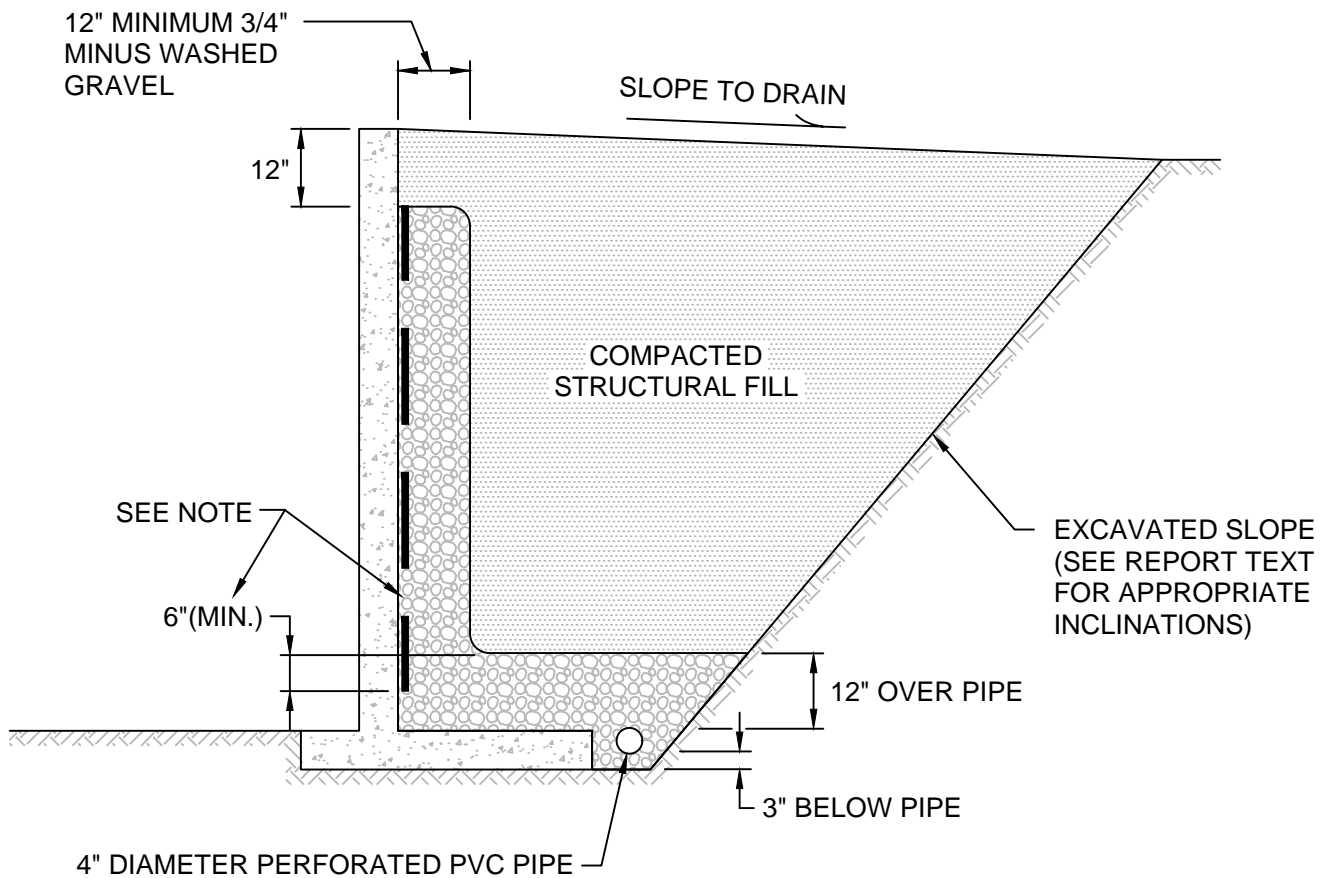

NOT TO SCALE

NOTE:

MIRADRAIN G100N PREFABRICATED DRAINAGE PANELS OR SIMILAR PRODUCT CAN BE SUBSTITUTED FOR THE 12-INCH WIDE GRAVEL DRAIN BEHIND WALL. DRAINAGE PANELS SHOULD EXTEND A MINIMUM OF SIX INCHES INTO 12-INCH THICK DRAINAGE GRAVEL LAYER OVER PERFORATED DRAIN PIPE.

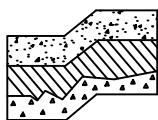

Terra Associates, Inc.
 Consultants in Geotechnical Engineering
 Geology and
 Environmental Earth Sciences

TYPICAL WALL DRAINAGE DETAIL
 WESLEY HOMES PUYALLUP
 PUYALLUP, WASHINGTON

Proj. No. T-5915-3

Date OCT 2015

Figure 4

APPENDIX A
FIELD EXPLORATION AND LABORATORY TESTING

Wesley Homes Puyallup
Puyallup, Washington



On October 13, 2015, we completed our site exploration by observing soil and groundwater conditions at 12 test pits. The test pits were excavated using a track-mounted excavator to a maximum depth of 15 feet below existing site grades. Test pit locations were determined in the field by using GPS coordinates from Google Earth. The approximate location of the test pits is shown on the attached Exploration Location Plan, Figure 2. Test Pit Logs are attached as Figures A-2 through A-13.

A geotechnical engineer from our office conducted the field exploration. Our representative classified the soil conditions encountered, maintained a log of each test pit, obtained representative soil samples, and recorded water levels observed during excavation. All soil samples were visually classified in accordance with the Unified Soil Classification System (USCS) described on Figure A-1.

Representative soil samples obtained from the test pits and test borings were placed in closed containers and taken to our laboratory for further examination and testing. The moisture content of each sample was measured and is reported on the individual Test Boring Logs. Grain size analyses were performed on selected samples. The results of the grain size analyses are shown on Figures A-14 and A-15.

MAJOR DIVISIONS			LETTER SYMBOL	TYPICAL DESCRIPTION	
COARSE GRAINED SOILS	More than 50% material larger than No. 200 sieve size	GRAVELS More than 50% of coarse fraction is larger than No. 4 sieve	Clean Gravels (less than 5% fines)	GW	Well-graded gravels, gravel-sand mixtures, little or no fines.
				GP	Poorly-graded gravels, gravel-sand mixtures, little or no fines.
			Gravels with fines	GM	Silty gravels, gravel-sand-silt mixtures, non-plastic fines.
				GC	Clayey gravels, gravel-sand-clay mixtures, plastic fines.
	More than 50% material smaller than No. 200 sieve size	SANDS More than 50% of coarse fraction is smaller than No. 4 sieve	Clean Sands (less than 5% fines)	SW	Well-graded sands, sands with gravel, little or no fines.
				SP	Poorly-graded sands, sands with gravel, little or no fines.
			Sands with fines	SM	Silty sands, sand-silt mixtures, non-plastic fines.
				SC	Clayey sands, sand-clay mixtures, plastic fines.
FINE GRAINED SOILS	SILTS AND CLAYS Liquid Limit is less than 50%		ML	Inorganic silts, rock flour, clayey silts with slight plasticity.	
			CL	Inorganic clays of low to medium plasticity. (Lean clay)	
			OL	Organic silts and organic clays of low plasticity.	
	SILTS AND CLAYS Liquid Limit is greater than 50%		MH	Inorganic silts, elastic.	
			CH	Inorganic clays of high plasticity. (Fat clay)	
			OH	Organic clays of high plasticity.	
HIGHLY ORGANIC SOILS			PT	Peat.	

DEFINITION OF TERMS AND SYMBOLS

COHESIONLESS	<u>Density</u>	<u>Standard Penetration Resistance in Blows/Foot</u>	 2" OUTSIDE DIAMETER SPILT SPOON SAMPLER
	Very Loose Loose Medium Dense Dense Very Dense	0-4 4-10 10-30 30-50 >50	 2.4" INSIDE DIAMETER RING SAMPLER OR SHELBY TUBE SAMPLER
COHESIVE	<u>Consistency</u>	<u>Standard Penetration Resistance in Blows/Foot</u>	 WATER LEVEL (Date)
	Very Soft Soft Medium Stiff Stiff Very Stiff Hard	0-2 2-4 4-8 8-16 16-32 >32	Tr TORVANE READINGS, tsf Pp PENETROMETER READING, tsf DD DRY DENSITY, pounds per cubic foot LL LIQUID LIMIT, percent PI PLASTIC INDEX N STANDARD PENETRATION, blows per foot

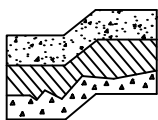

Terra Associates, Inc.
 Consultants in Geotechnical Engineering
 Geology and Environmental Earth Sciences

**UNIFIED SOIL CLASSIFICATION SYSTEM
 WESLEY HOMES PUYALLUP
 PUYALLUP, WASHINGTON**

Proj. No.T-5915-3

Date NOV 2016

Figure A-1

LOG OF TEST PIT NO. TP-101

FIGURE A-2

PROJECT NAME: Wesley Homes Puyallup PROJ. NO: T-5915-3 LOGGED BY: CSD
 LOCATION: Puyallup, Washington SURFACE CONDS: Tall Understory APPROX. ELEV: 456 +/- Ft.
 DATE LOGGED: October 13, 2015 DEPTH TO GROUNDWATER: N/A DEPTH TO CAVING: N/A

DEPTH (FT.)	SAMPLE NO.	DESCRIPTION	CONSISTENCY/ RELATIVE DENSITY	W (%)	POCKET PEN. (TSF)	REMARKS
1		Black silty SAND, fine grained, moist, heavy organic inclusions. (SM) (TOPSOIL)	Loose			
2	1	Brown SAND with silty and gravel, fine to medium grained, dry, roots. (SP-SM)	Medium Dense	8.1		
3						
4						
5		Gray silty SAND with gravel, fine to medium grained, moist, cemented. (SM)	Dense			
6	2			6.7		
7						
8						
9		Brown SAND with gravel, medium to coarse grained, moist. (SP)	Dense			
10	3			5.5		
11		Test pit terminated at approximately 10 feet. No groundwater seepage observed.				
12						
13						
14						
15						

NOTE: This subsurface information pertains only to this test pit location and should not be interpreted as being indicative of other locations at the site.



Terra Associates, Inc.
 Consultants in Geotechnical Engineering
 Geology and
 Environmental Earth Sciences

LOG OF TEST PIT NO. TP-102

FIGURE A-3

PROJECT NAME: Wesley Homes Puyallup PROJ. NO: T-5915-3 LOGGED BY: CSD
 LOCATION: Puyallup, Washington SURFACE CONDS: Low Grass/Weeds APPROX. ELEV: 458 +/- Ft.
 DATE LOGGED: October 13, 2015 DEPTH TO GROUNDWATER: N/A DEPTH TO CAVING: N/A

DEPTH (FT.)	SAMPLE NO.	DESCRIPTION	CONSISTENCY/ RELATIVE DENSITY	W (%)	POCKET PEN. (TSF)	REMARKS
1	1	(2 inches ORGANICS) Red-brown SAND with silt and gravel, fine to medium grained, moist. (SP-SM)	Medium Dense	3.1		
2						
3						
4		Gray SAND with gravel to GRAVEL with sand, medium to coarse grained, dry. (SP/GP)	Medium Dense			
5						
6	2			36.9		
7						
8	3	Gray SILT, fine grained, moist, very small sand interbeds, upper two feet mottled.	Medium Stiff	36.8		
9						
10		LL=35 PL=26 PI=9				
11						
12		Brown SAND with silt and gravel to GRAVEL with silt and sand, medium to coarse grained, wet to saturated. (SP-SM/GP-GM)	Dense			
13	4			12.1		
14		Test pit terminated at approximately 13 feet. No groundwater seepage observed.				
15						

NOTE: This subsurface information pertains only to this test pit location and should not be interpreted as being indicative of other locations at the site.



Terra Associates, Inc.
 Consultants in Geotechnical Engineering
 Geology and
 Environmental Earth Sciences

LOG OF TEST PIT NO. TP-103

FIGURE A-4

PROJECT NAME: Wesley Homes Puyallup PROJ. NO: T-5915-3 LOGGED BY: CSD
 LOCATION: Puyallup, Washington SURFACE CONDS: Tall Blackberries APPROX. ELEV: 451 +/- Ft.
 DATE LOGGED: October 13, 2015 DEPTH TO GROUNDWATER: N/A DEPTH TO CAVING: N/A

DEPTH (FT.)	SAMPLE NO.	DESCRIPTION	CONSISTENCY/ RELATIVE DENSITY	W (%)	POCKET PEN. (TSF)	REMARKS
1	1	(6 inches ORGANICS)		10.4		
2						
3						
4						
5	2			18.5		
6		FILL: black with some brown and gray silty sand with gravel and sand with silt and gravel, fine to medium grained, moist, heavy organic inclusions including large logs and cut wood.	Medium Dense			
7						
8						
9						
10						
11						
12						
13						
14						
15	3			Gray silty SAND, fine to medium grained, wet. (SM)	Medium Dense	21.2
16		Test pit terminated at approximately 15 feet. No groundwater seepage observed.				
17						
18						
19						
20						

NOTE: This subsurface information pertains only to this test pit location and should not be interpreted as being indicative of other locations at the site.



Terra Associates, Inc.
 Consultants in Geotechnical Engineering
 Geology and
 Environmental Earth Sciences

LOG OF TEST PIT NO. TP-104

FIGURE A-5

PROJECT NAME: Wesley Homes Puyallup PROJ. NO: T-5915-3 LOGGED BY: CSD
 LOCATION: Puyallup, Washington SURFACE CONDS: Tall Brush APPROX. ELEV: 458 +/- Ft.
 DATE LOGGED: October 13, 2015 DEPTH TO GROUNDWATER: N/A DEPTH TO CAVING: N/A

DEPTH (FT.)	SAMPLE NO.	DESCRIPTION	CONSISTENCY/ RELATIVE DENSITY	W (%)	POCKET PEN. (TSF)	REMARKS
1	1	(8 inches ORGANICS) Brown SAND with silt and gravel to silty SAND with gravel, fine to medium grained, dry.	Medium Dense	10.4		
2			Medium Dense			
3			Medium Dense			
4	2			6.5		
5		Gray silty GRAVEL with sand to silty SAND with gravel, fine to medium grained, moist, some cobbles. (GM/SM)	Dense			
6						
7						
8						
9						
10		Gray SAND with silt and gravel, fine to coarse grained, wet. (SP-SM)	Dense			
11	3			11.0		
12		Test pit terminated at approximately 11 feet. No groundwater seepage observed.				
13						
14						
15						

NOTE: This subsurface information pertains only to this test pit location and should not be interpreted as being indicative of other locations at the site.



Terra Associates, Inc.
 Consultants in Geotechnical Engineering
 Geology and
 Environmental Earth Sciences

LOG OF TEST PIT NO. TP-105

FIGURE A-6

PROJECT NAME: Wesley Homes Puyallup PROJ. NO: T-5915-3 LOGGED BY: CSD
 LOCATION: Puyallup, Washington SURFACE CONDS: Tall Blackberries APPROX. ELEV: 454 +/- Ft.
 DATE LOGGED: October 13, 2015 DEPTH TO GROUNDWATER: N/A DEPTH TO CAVING: N/A

DEPTH (FT.)	SAMPLE NO.	DESCRIPTION	CONSISTENCY/ RELATIVE DENSITY	W (%)	POCKET PEN. (TSF)	REMARKS
1		(8 inches ORGANICS)				
	1			8.4		
2		Brown SAND with silt and gravel, fine to coarse grained, dry to moist, roots. (SP-SM)	Medium Dense			
3						
4						
5	2					
6						
7	3	Gray SILT, fine grained, moist, upper two feet mottled. (ML)	Medium Stiff to Stiff	19.8		
8						
9						
10	4					
11		Test pit terminated at approximately 10.5 feet. No groundwater seepage observed.				
12						
13						
14						
15						

NOTE: This subsurface information pertains only to this test pit location and should not be interpreted as being indicative of other locations at the site.



Terra Associates, Inc.
 Consultants in Geotechnical Engineering
 Geology and
 Environmental Earth Sciences

LOG OF TEST PIT NO. TP-106

FIGURE A-7

PROJECT NAME: Wesley Homes Puyallup PROJ. NO: T-5915-3 LOGGED BY: CSD
 LOCATION: Puyallup, Washington SURFACE CONDS: Tall Grass APPROX. ELEV: 452 +/- Ft.
 DATE LOGGED: October 13, 2015 DEPTH TO GROUNDWATER: N/A DEPTH TO CAVING: N/A

DEPTH (FT.)	SAMPLE NO.	DESCRIPTION	CONSISTENCY/ RELATIVE DENSITY	W (%)	POCKET PEN. (TSF)	REMARKS
1		(8 inches ORGANICS)				
	1			6.6		
2		Gray SAND, fine grained, moist, some silt and gravel. (SP)	Medium Dense			
3						
4						
5	2			18.8		
6						
7						
	3	Gray SILT, fine grained, moist, upper two feet mottled. (ML)	Medium Stiff to Very Stiff	30.1		
8						
9						
10	4	Brown silty SAND with gravel, fine to medium grained, moist to wet. (SM)	Dense	13.1		
11		Test pit terminated at approximately 10.5 feet. No groundwater seepage observed.				
12						
13						
14						
15						

NOTE: This subsurface information pertains only to this test pit location and should not be interpreted as being indicative of other locations at the site.



Terra Associates, Inc.
 Consultants in Geotechnical Engineering
 Geology and
 Environmental Earth Sciences

LOG OF TEST PIT NO. TP-107

FIGURE A-8

PROJECT NAME: Wesley Homes Puyallup PROJ. NO: T-5915-3 LOGGED BY: CSD
 LOCATION: Puyallup, Washington SURFACE CONDS: Forest Duff APPROX. ELEV: 452 +/- Ft.
 DATE LOGGED: October 13, 2015 DEPTH TO GROUNDWATER: 7 Feet DEPTH TO CAVING: N/A

DEPTH (FT.)	SAMPLE NO.	DESCRIPTION	CONSISTENCY/ RELATIVE DENSITY	W (%)	POCKET PEN. (TSF)	REMARKS
1		Dark brown silty SAND, fine to medium grained, moist. (SM) (TOPSOIL)	Loose			
2						
3	1	Gray silty SAND, fine grained, moist, roots. (SM)	Medium Dense	12.1		
4						
5						
6						
7	2	Brown SAND with silt, medium to coarse grained, wet to saturated. (SP-SM)	Medium Dense	21.7		
8						
9						
10	3	Brown GRAVEL with silt and sand, medium to coarse grained, saturated. (GP-GM)	Dense	8.3		
11		Test pit terminated at approximately 10 feet. Heavy groundwater seepage observed at 7 feet.				
12						
13						
14						
15						

NOTE: This subsurface information pertains only to this test pit location and should not be interpreted as being indicative of other locations at the site.



Terra Associates, Inc.
 Consultants in Geotechnical Engineering
 Geology and
 Environmental Earth Sciences

LOG OF TEST PIT NO. TP-108

FIGURE A-9

PROJECT NAME: Wesley Homes Puyallup PROJ. NO: T-5915-3 LOGGED BY: CSD
 LOCATION: Puyallup, Washington SURFACE CONDS: Tall Understory APPROX. ELEV: 456 +/- Ft.
 DATE LOGGED: October 13, 2015 DEPTH TO GROUNDWATER: N/A DEPTH TO CAVING: N/A

DEPTH (FT.)	SAMPLE NO.	DESCRIPTION	CONSISTENCY/ RELATIVE DENSITY	W (%)	POCKET PEN. (TSF)	REMARKS
1	1	(8 inches ORGANICS)		7.2		
2			Medium Dense			
3		Brown to gray silty SAND to silty SAND with gravel, fine grained, moist, some cementation. (SM)				
4			Dense			
6	2			9.3		
7						
8	3			8.4		
9		Gray SAND with silt and gravel, medium to coarse grained, moist to wet. (SP-SM)				
10	4		Dense	13.9		
11		Test pit terminated at approximately 11 feet. No groundwater seepage observed.				
12						
13						
14						
15						

NOTE: This subsurface information pertains only to this test pit location and should not be interpreted as being indicative of other locations at the site.



Terra Associates, Inc.
 Consultants in Geotechnical Engineering
 Geology and
 Environmental Earth Sciences

LOG OF TEST PIT NO. TP-109

FIGURE A-10

PROJECT NAME: Wesley Homes Puyallup PROJ. NO: T-5915-3 LOGGED BY: CSD
 LOCATION: Puyallup, Washington SURFACE CONDS: Tall Brush APPROX. ELEV: 454 +/- Ft.
 DATE LOGGED: October 13, 2015 DEPTH TO GROUNDWATER: 11.5 Feet DEPTH TO CAVING: N/A

DEPTH (FT.)	SAMPLE NO.	DESCRIPTION	CONSISTENCY/ RELATIVE DENSITY	W (%)	POCKET PEN. (TSF)	REMARKS
1	1	(8 inches ORGANICS)		15.1		
2		Gray sandy SILT to silty SAND, fine grained, moist. (ML/SM)	Medium Dense			
3						
4						
5	2			5.8		
6						
7		Brown GRAVEL with sand, fine to medium grained, moist. (GP)	Medium Dense			
8						
9	3			8.0		
10						
11						
12	4			13.4		
13		Test pit terminated at approximately 12 feet. Heavy groundwater seepage observed at 11.5 feet.				
14						
15						

NOTE: This subsurface information pertains only to this test pit location and should not be interpreted as being indicative of other locations at the site.



Terra Associates, Inc.
 Consultants in Geotechnical Engineering
 Geology and
 Environmental Earth Sciences

LOG OF TEST PIT NO. TP-110

FIGURE A-11

PROJECT NAME: Wesley Homes Puyallup PROJ. NO: T-5915-3 LOGGED BY: CSD
 LOCATION: Puyallup, Washington SURFACE CONDS: Tall Understory APPROX. ELEV: 454 +/- Ft.
 DATE LOGGED: October 13, 2015 DEPTH TO GROUNDWATER: 11 Feet DEPTH TO CAVING: N/A

DEPTH (FT.)	SAMPLE NO.	DESCRIPTION	CONSISTENCY/ RELATIVE DENSITY	W (%)	POCKET PEN. (TSF)	REMARKS
1		(8 inches ORGANICS)				
1	1	Gray SILT with sand, fine grained, moist, upper two feet mottled, trace gravel. (ML)	Medium Dense	14.8		
2						
3				4.9		
4	2	Brown GRAVEL with silt and sand, fine to coarse grained, moist. (GP-GM)				
5						
6		*At 6 feet soil becomes wet.				
7	3		Medium Dense	12.1		
8						
9						
10						
11		Test pit terminated at approximately 11 feet. Heavy groundwater seepage observed at 11 feet.				
12						
13						
14						
15						

NOTE: This subsurface information pertains only to this test pit location and should not be interpreted as being indicative of other locations at the site.



Terra Associates, Inc.
 Consultants in Geotechnical Engineering
 Geology and
 Environmental Earth Sciences

LOG OF TEST PIT NO. TP-111

FIGURE A-12

PROJECT NAME: Wesley Homes Puyallup PROJ. NO: T-5915-3 LOGGED BY: CSD
 LOCATION: Puyallup, Washington SURFACE CONDS: Tall Understory APPROX. ELEV: 466 +/- Ft.
 DATE LOGGED: October 13, 2015 DEPTH TO GROUNDWATER: N/A DEPTH TO CAVING: N/A

DEPTH (FT.)	SAMPLE NO.	DESCRIPTION	CONSISTENCY/ RELATIVE DENSITY	W (%)	POCKET PEN. (TSF)	REMARKS
1		Dark brown silty SAND, fine grained, moist, heavy organic inclusions. (SM) (TOPSOIL)	Loose			
2		Brown silty SAND with gravel, fine to medium grained, moist. (SM)	Medium Dense	12.6		
3	1					
4						
5		Gray silty SAND with gravel, fine to medium grained, moist, upper two feet mottled, occasional cobble/boulder. (SM)	Medium Dense	11.4		
6	2					
7						
8						
9		Dense	7.8			
10	3					
11						
12		Test pit terminated at approximately 11 feet. No groundwater seepage observed.				
13						
14						
15						

NOTE: This subsurface information pertains only to this test pit location and should not be interpreted as being indicative of other locations at the site.



Terra Associates, Inc.
 Consultants in Geotechnical Engineering
 Geology and
 Environmental Earth Sciences

LOG OF TEST PIT NO. TP-112

FIGURE A-13

PROJECT NAME: Wesley Homes Puyallup PROJ. NO: T-5915-3 LOGGED BY: CSD
 LOCATION: Puyallup, Washington SURFACE CONDS: Forest Duff APPROX. ELEV: 474 +/- Ft.
 DATE LOGGED: October 13, 2015 DEPTH TO GROUNDWATER: N/A DEPTH TO CAVING: N/A

DEPTH (FT.)	SAMPLE NO.	DESCRIPTION	CONSISTENCY/ RELATIVE DENSITY	W (%)	POCKET PEN. (TSF)	REMARKS
1		Dark brown silty SAND, fine grained, moist, heavy organic inclusions. (SM) (TOPSOIL)	Loose			
2	1	Red-brown to brown SAND with silt and gravel to silty SAND with gravel, fine to medium grained, dry. (SP-SM/SM)	Medium Dense	7.6		
3						
4						
5	2	Brown GRAVEL with sand, medium to coarse grained, dry. (GP)	Medium Dense	1.9		
6						
7						
8						
9	3	Gray silty SAND with gravel, fine to medium grained, moist. (SM)	Dense	5.8		
10						
11		Test pit terminated at approximately 10 feet. No groundwater seepage observed.				
12						
13						
14						
15						

NOTE: This subsurface information pertains only to this test pit location and should not be interpreted as being indicative of other locations at the site.



Terra Associates, Inc.
 Consultants in Geotechnical Engineering
 Geology and
 Environmental Earth Sciences

Particle Size Distribution Report

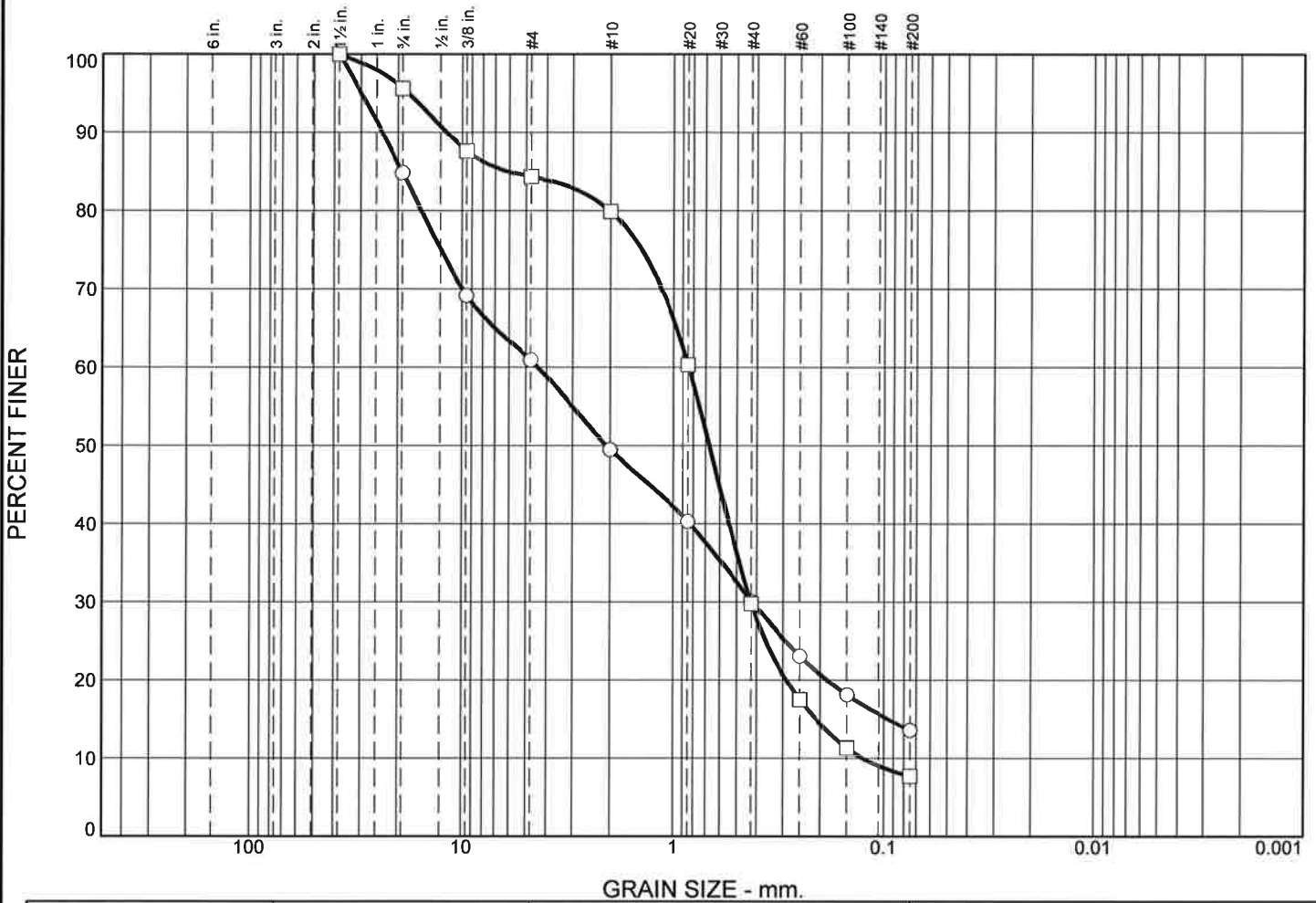

	% +3"	% Gravel		% Sand			% Fines	
		Coarse	Fine	Coarse	Medium	Fine	Silt	Clay
○	0.0	15.2	23.9	11.4	19.4	16.5	13.6	
□	0.0	4.4	11.3	4.4	50.1	22.1	7.7	

	LL	PL	D85	D60	D50	D30	D15	D10	Cc	Cu
○			19.2109	4.4000	2.0841	0.4221	0.0955			
□			6.0908	0.8436	0.6729	0.4274	0.2101	0.1259	1.72	6.70

Material Description	USCS	AASHTO
○ Silty SAND with gravel	SM	
□ Well graded SAND with silt and gravel	SW-SM	

<p>Project No. T-5915-3 Client: Wesley Homes</p> <p>Project: Wesley Homes Puyallup Puyallup, Washington</p> <p>○ Location: Test Pit TP-101 Depth: -5.5 feet Sample Number: 2</p> <p>□ Location: Test Pit TP-105 Depth: -1.5 feet Sample Number: 1</p> <p style="text-align: center;">Terra Associates, Inc.</p> <p style="text-align: center;">Kirkland, WA</p>	<p>Remarks:</p> <p>○ Tested on 10/15/2015</p> <p>□ Tested on 10/15/2015</p>
---	--

Figure A-14

Tested By: FQ

Particle Size Distribution Report

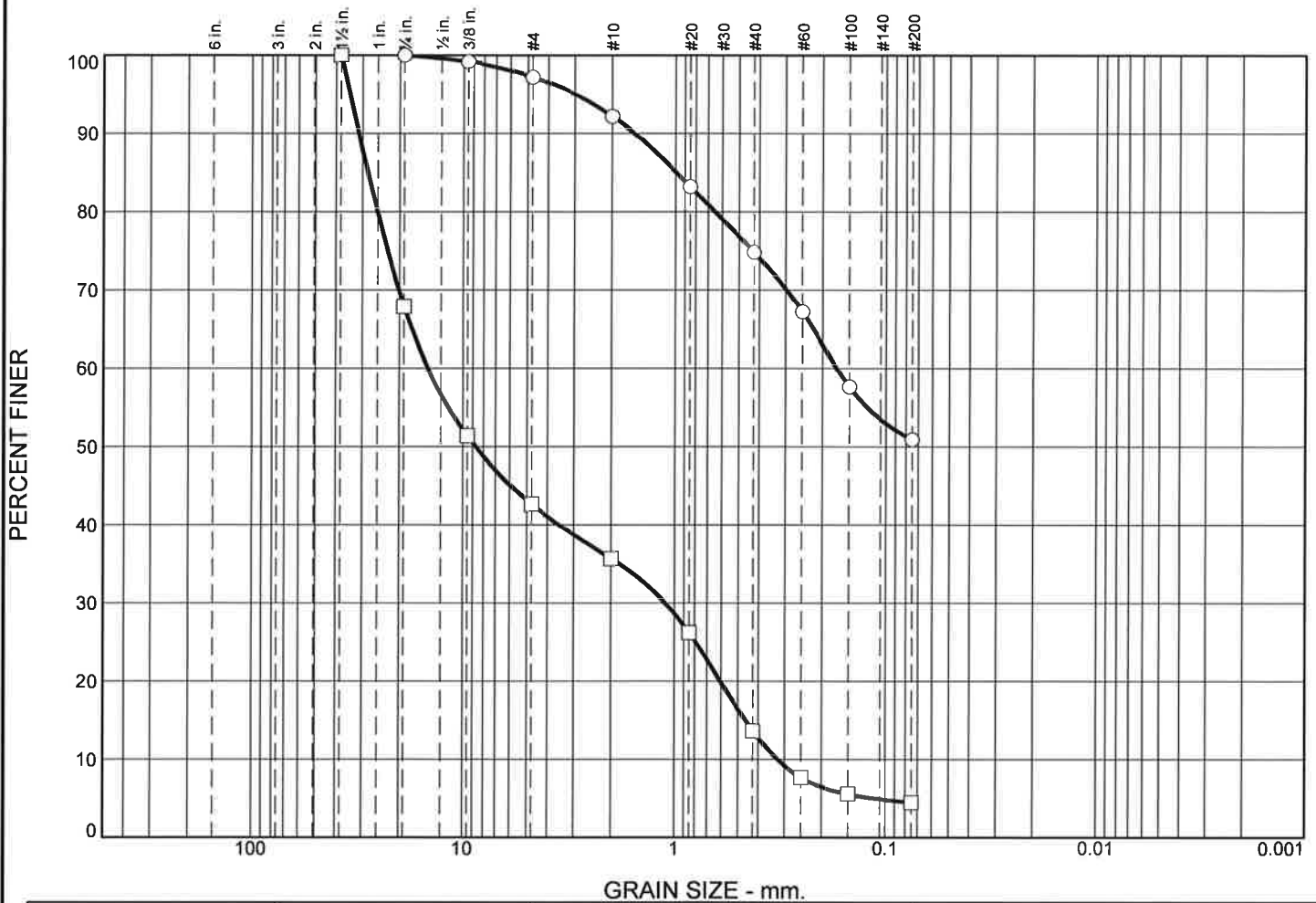

	% +3"	% Gravel		% Sand			% Fines	
		Coarse	Fine	Coarse	Medium	Fine	Silt	Clay
○	0.0	0.0	2.8	5.0	17.4	23.9	50.9	
□	0.0	32.1	25.3	6.9	22.1	9.1	4.5	

LL	PL	D ₈₅	D ₆₀	D ₅₀	D ₃₀	D ₁₅	D ₁₀	C _c	C _u
○		0.9912	0.1722						
□		28.3351	14.6713	8.7037	1.1078	0.4626	0.3242	0.26	45.25

Material Description	USCS	AASHTO
○ Sandy SILT	ML	
□ Poorly graded GRAVEL with sand	GP	

<p>Project No. T-5915-3 Client: Wesley Homes</p> <p>Project: Wesley Homes Puyallup Puyallup, Washington</p> <p>○ Location: Test Pit TP-109 Depth: -1 foot Sample Number: 1</p> <p>□ Location: Test Pit TP-109 Depth: -8.5 feet Sample Number: 3</p> <p style="text-align: center;">Terra Associates, Inc.</p> <p style="text-align: center;">Kirkland, WA</p>	<p>Remarks:</p> <p>○ Tested on 10/15/2015</p> <p>□ Tested on 10/15/2015</p>
---	--

Figure A-15

Tested By: FQ

APPENDIX B

PREVIOUS TEST PIT LOGS

LOG OF TEST PIT NO. 1

FIGURE A-2

PROJECT NAME: Puyallup Senior Housing Project PROJ. NO: T-5915-1 LOGGED BY: TA
 LOCATION: Puyallup, Washington SURFACE CONDS: _____ ELEV: 474
 DATE LOGGED: August 3, 2006 DEPTH TO GROUNDWATER: N/A DEPTH TO CAVING: N/A

DEPTH (FT.)	SAMPLE NO.	DESCRIPTION	CONSISTENCY/ RELATIVE DENSITY	W (%)	POCKET PEN. (TSF)	REMARKS
5		(9 inches TOPSOIL) Brown sandy GRAVEL, dry. (GP) Moist below 5 feet.	Dense	2.5		
10		Brown sandy GRAVEL, dry. (GP)	Dense	5.3		
15		Test pit terminated at 11 feet. No groundwater seepage was observed. No caving was observed.				

NOTE: This subsurface information pertains only to this test pit location and should not be interpreted as being indicative of other locations at the site.



Terra Associates, Inc.
 Consultants in Geotechnical Engineering
 Geology and
 Environmental Earth Sciences

LOG OF TEST PIT NO. 2

FIGURE A-3

PROJECT NAME: Puyallup Senior Housing Project PROJ. NO: T-5915-1 LOGGED BY: TA

LOCATION: Puyallup, Washington SURFACE CONDS: _____ ELEV: 458

DATE LOGGED: August 3, 2006 DEPTH TO GROUNDWATER: N/A DEPTH TO CAVING: N/A

DEPTH (FT.)	SAMPLE NO.	DESCRIPTION	CONSISTENCY/ RELATIVE DENSITY	W (%)	POCKET PEN. (TSF)	REMARKS
5		(6 inches TOPSOIL) Brown silty SAND, moist to dry. (SM) Very dense below 5 feet.	Medium Dense	8.3 11.4		
10		Brown gravelly SAND, dry. (SP)	Very Dense	4.5		
15		Test pit terminated at 10 feet. No groundwater seepage was observed. No caving was observed.				

NOTE: This subsurface information pertains only to this test pit location and should not be interpreted as being indicative of other locations at the site.



Terra Associates, Inc.
 Consultants in Geotechnical Engineering
 Geology and
 Environmental Earth Sciences

LOG OF TEST PIT NO. 3

FIGURE A-4

PROJECT NAME: Puyallup Senior Housing Project PROJ. NO: T-5915-1 LOGGED BY: TA

LOCATION: Puyallup, Washington SURFACE CONDS: _____ ELEV: 458

DATE LOGGED: August 3, 2006 DEPTH TO GROUNDWATER: N/A DEPTH TO CAVING: N/A

DEPTH (FT.)	SAMPLE NO.	DESCRIPTION	CONSISTENCY/ RELATIVE DENSITY	W (%)	POCKET PEN. (TSF)	REMARKS
		(12 inches TOPSOIL)				
		Brown sandy SILT with gravels, oxidallon staining, moist. (ML)	Medlum Danse	11.7		
5		Gray sandy SILT, cemented, moist. (ML)	Dense	13.8		LL=21 PL=18 PI=3
10		Test pit terminated at 8 feet. No groundwater seepage was observed. No caving was observed.				
15						

NOTE: This subsurface information pertains only to this test pit location and should not be interpreted as being indicative of other locations at the site.



Terra Associates, Inc.
 Consultants in Geotechnical Engineering
 Geology and
 Environmental Earth Sciences

LOG OF TEST PIT NO. 4

FIGURE A-5

PROJECT NAME: Puyallup Senior Housing Project PROJ. NO: T-5915-1 LOGGED BY: TA
 LOCATION: Puyallup, Washington SURFACE CONDS: _____ ELEV: 466
 DATE LOGGED: August 3, 2006 DEPTH TO GROUNDWATER: N/A DEPTH TO CAVING: N/A

DEPTH (FT.)	SAMPLE NO.	DESCRIPTION	CONSISTENCY/ RELATIVE DENSITY	W (%)	POCKET PEN. (TSF)	REMARKS
5		(6 inches TOPSOIL) Brown gray silty SAND with oxidation staining, moist. (SM) Very dense below 3 feet.	Dense	18.6		
10		Test pit terminated at 8 feet. No groundwater seepage was observed. No caving was observed.				
15						

NOTE: This subsurface information pertains only to this test pit location and should not be interpreted as being indicative of other locations at the site.



Terra Associates, Inc.
 Consultants In Geotechnical Engineering
 Geology and
 Environmental Earth Sciences

LOG OF TEST PIT NO. 5

FIGURE A-6

PROJECT NAME: Puyallup Senior Housing Project PROJ. NO: T-5915-1 LOGGED BY: TA

LOCATION: Puyallup, Washington SURFACE CONDS: _____ ELEV: 453

DATE LOGGED: August 3, 2006 DEPTH TO GROUNDWATER: N/A DEPTH TO CAVING: N/A

DEPTH (FT.)	SAMPLE NO.	DESCRIPTION	CONSISTENCY/ RELATIVE DENSITY	W (%)	POCKET PEN. (TSF)	REMARKS
5		(9 inches TOPSOIL) Brown gray silty SAND with gravel, cemented, moist. (SM)	Very Dense	11.6 8.3		
10		Test pit terminated at 7 feet. No groundwater seepage was observed. No caving was observed.				
15						

NOTE: This subsurface information pertains only to this test pit location and should not be interpreted as being indicative of other locations at the site.



Terra Associates, Inc.
 Consultants in Geotechnical Engineering
 Geology and
 Environmental Earth Sciences

LOG OF TEST PIT NO. 6

FIGURE A-7

PROJECT NAME: Puyallup Senior Housing Project PROJ. NO: T-5915-1 LOGGED BY: TA

LOCATION: Puyallup, Washington SURFACE CONDS: _____ ELEV: 458

DATE LOGGED: August 3, 2006 DEPTH TO GROUNDWATER: N/A DEPTH TO CAVING: N/A

DEPTH (FT.)	SAMPLE NO.	DESCRIPTION	CONSISTENCY/ RELATIVE DENSITY	W (%)	POCKET PEN. (TSF)	REMARKS
		(9 Inches TOPSOIL)				
		Brown SAND, dry to moist. (SP)	Medium Dense	8.3		
5		Brown sandy GRAVEL to gravelly SAND, moist. (GP-SP)	Dense to Very Dense	3.0 3.2		
10		Test pit terminated at 8 feet. No groundwater seepage was observed. No caving was observed.				
15						

NOTE: This subsurface information pertains only to this test pit location and should not be interpreted as being indicative of other locations at the site.



Terra Associates, Inc.
 Consultants in Geotechnical Engineering
 Geology and
 Environmental Earth Sciences

LOG OF TEST PIT NO. 7

FIGURE A-8

PROJECT NAME: Puyallup Senior Housing Project PROJ. NO: T-5915-1 LOGGED BY: TA

LOCATION: Puyallup, Washington SURFACE CONDS: _____ ELEV: 455

DATE LOGGED: August 3, 2006 DEPTH TO GROUNDWATER: N/A DEPTH TO CAVING: N/A

DEPTH (FT.)	SAMPLE NO.	DESCRIPTION	CONSISTENCY/ RELATIVE DENSITY	W (%)	POCKET PEN. (TSF)	REMARKS
5		(12 inches TOPSOIL) Brown gravelly SAND, dry. (SP)	Dense	5.9		
10		Brown SAND, dry. (SP)	Dense	5.2		
15		Brown gray sandy SILT to SILT with oxidation staining, moist. (ML)	Hard	23.4		
		Test pit terminated at 12 feet. No groundwater seepage was observed. No caving was observed.				

NOTE: This subsurface information pertains only to this test pit location and should not be interpreted as being indicative of other locations at the site.



Terra Associates, Inc.
 Consultants in Geotechnical Engineering
 Geology and
 Environmental Earth Sciences

LOG OF TEST PIT NO. 8

FIGURE A-9

PROJECT NAME: Puyallup Senior Housing Project PROJ. NO: T-6915-1 LOGGED BY: TA

LOCATION: Puyallup, Washington SURFACE CONDS: _____ ELEV: 448

DATE LOGGED: August 3, 2006 DEPTH TO GROUNDWATER: N/A DEPTH TO CAVING: N/A

DEPTH (FT.)	SAMPLE NO.	DESCRIPTION	CONSISTENCY/ RELATIVE DENSITY	W (%)	POCKET PEN. (TSF)	REMARKS
5		(8 inches TOPSOIL)		8.0		
10		UNCONTROLLED FILL: dark brown black silty sand with decayed wood, trace branches, roots, moist. (SM)	Loose	18.8		
15		Gray sandy SILT to SILT, moist. (ML)	Medium Stiff	29.5		
20		Test pit terminated at 15 feet. No groundwater seepage was observed. No caving was observed.				

NOTE: This subsurface information pertains only to this test pit location and should not be interpreted as being indicative of other locations at the site.



Terra Associates, Inc.
 Consultants in Geotechnical Engineering
 Geology and
 Environmental Earth Sciences

LOG OF TEST PIT NO. 9

FIGURE A-10

PROJECT NAME: Puyallup Senior Housing Project PROJ. NO: T-5915-1 LOGGED BY: TA

LOCATION: Puyallup, Washington SURFACE CONDS: _____ ELEV: 462

DATE LOGGED: August 3, 2006 DEPTH TO GROUNDWATER: N/A DEPTH TO CAVING: N/A

DEPTH (FT.)	SAMPLE NO.	DESCRIPTION	CONSISTENCY/ RELATIVE DENSITY	W (%)	POCKET PEN. (TSF)	REMARKS
		(9 inches TOPSOIL)				
		Brown silty SAND with gravel, dry. (SM)	Medium Dense	5.9		
5		Brown gravelly SAND, dry. (SP)	Very Dense	3.6		
10		Test pit terminated at 8 feet. No groundwater seepage was observed. No caving was observed.				
15						

NOTE: This subsurface information pertains only to this test pit location and should not be interpreted as being indicative of other locations at the site.



Terra Associates, Inc.
 Consultants in Geotechnical Engineering
 Geology and
 Environmental Earth Sciences

LOG OF TEST PIT NO. 10

FIGURE A-11

PROJECT NAME: Puyallup Senior Housing Project PROJ. NO: T-5915-1 LOGGED BY: TA

LOCATION: Puyallup, Washington SURFACE CONDS: _____ ELEV: 462

DATE LOGGED: August 3, 2006 DEPTH TO GROUNDWATER: N/A DEPTH TO CAVING: N/A

DEPTH (FT.)	SAMPLE NO.	DESCRIPTION	CONSISTENCY/ RELATIVE DENSITY	W (%)	POCKET PEN. (TSF)	REMARKS
5		(9 inches TOPSOIL) Brown silty SAND with gravel, dry to moist. (SM)	Medium Dense	3.6		
10		Test pit terminated at 6 feet. No groundwater seepage was observed. No caving was observed.				
15						

NOTE: This subsurface information pertains only to this test pit location and should not be interpreted as being indicative of other locations at the site.



Terra Associates, Inc.
 Consultants in Geotechnical Engineering
 Geology and
 Environmental Earth Sciences

LOG OF TEST PIT NO. 11

FIGURE A-12

PROJECT NAME: Puyallup Senior Housing Project PROJ. NO: T-5915-1 LOGGED BY: TA
 LOCATION: Puyallup, Washington SURFACE CONDS: _____ ELEV: 469
 DATE LOGGED: August 3, 2006 DEPTH TO GROUNDWATER: N/A DEPTH TO CAVING: N/A

DEPTH (FT.)	SAMPLE NO.	DESCRIPTION	CONSISTENCY/ RELATIVE DENSITY	W (%)	POCKET PEN. (TSF)	REMARKS
5		(12 inches TOPSOIL) Yellow brown gravelly SAND, dry. (SP)	Very Dense	3.9		
10		Test pit terminated at 6 feet. No groundwater seepage was observed. No caving was observed.				
15						

NOTE: This subsurface information pertains only to this test pit location and should not be interpreted as being indicative of other locations at the site.



Terra Associates, Inc.
 Consultants in Geotechnical Engineering
 Geology and
 Environmental Earth Sciences

LOG OF TEST PIT NO. 12

FIGURE A-13

PROJECT NAME: Puyallup Senior Housing Project PROJ. NO: T-5915-1 LOGGED BY: TA

LOCATION: Puyallup, Washington SURFACE CONDS: _____ ELEV: 472

DATE LOGGED: August 3, 2006 DEPTH TO GROUNDWATER: N/A DEPTH TO CAVING: N/A

DEPTH (FT.)	SAMPLE NO.	DESCRIPTION	CONSISTENCY/ RELATIVE DENSITY	W (%)	POCKET PEN. (TSF)	REMARKS
		(9 inches TOPSOIL)				
		Reddish-brown silty SAND with gravel, dry. (SM)	Medium Dense	8.4		
5		Brown sandy GRAVEL, dry. (GP)	Very Dense	5.8		
10		Test pit terminated at 7 feet. No groundwater seepage was observed. No caving was observed.				
15						

NOTE: This subsurface information pertains only to this test pit location and should not be interpreted as being indicative of other locations at the site.



Terra Associates, Inc.
 Consultants in Geotechnical Engineering
 Geology and
 Environmental Earth Sciences

Date Excavated: 03/27/03

Logged by: EWB

Equipment: Case 580L Backhoe

Surface Elevation (ft): 450

Elevation feet	Depth feet	Sample Number	Water	Graphic Log	Group Symbol	MATERIAL DESCRIPTION	Water Content, %	Dry Unit Weight, lbs/ft ³	OTHER TESTS AND NOTES
450	0				SOD	2- to 6-inch grass and sod			
					SM	Black silty fine to coarse sand, trace organic material (loose, moist)			
		1			SM	Dark brown-black silty sand, trace gravel, occasional wood fragments (loose, moist) (fill)	31		
					SP-SM	Dark brown-black fine to coarse sand with silt and gravel, occasional organic material and cobbles (medium dense, moist) (fill)			
445	5								
		2					31		
440	10								
		3			SM	Green/gray silty fine sand with occasional coarse sand, fine gravel, roots (loose, moist) (native)			
435	15								
						Test pit completed at at depth of 15 feet on 03/27/03 Slow groundwater seepage observed at a depth of 5 feet Minor caving observed at depths between 0 and 2 feet			
430	20								

Note: See Figure A-1 for explanation of symbols
The depths of the test pit logs are based on an average of measurements across the test pit and should be considered accurate to 0.5 foot.

LOG OF TEST PIT 11



Project: Puyallup Retail Center
Project Location: Puyallup, Washington
Project Number: 3443-002-00

Figure: A-12
Sheet 1 of 1

3443-002-00 GEI GT 1.0 P:\3443002\00\FINALS\3443002\TESTPITS.GPJ GEIV2 2.GDT 4/23/03

Date Excavated: 03/27/03

Logged by: EWH

Equipment: Case 580L Backhoe

Surface Elevation (ft): 451

Elevation feet	Depth feet	Sample Number	Water	Graphic Log	Group Symbol	MATERIAL DESCRIPTION	Water Content, %	Dry Unit Weight, lbs/ft ³	OTHER TESTS AND NOTES
0					DUF	6-inch forest duff			
-450					SM	Dark brown silty sand with gravel, trace cobbles (loose, moist) (fill)			
		1			SP	Gray fine to coarse sand with gravel, trace silt (loose, moist) (fill)	4		
-445					ML	Light brown sandy silt (medium stiff, moist) (fill)			
		2			ML	Light brown sandy silt, trace gravel (medium stiff, moist) (fill)	32		
-440					GP	Light brown gravel with sand, trace silt (very dense, moist)			
		3							
-435									
20									

Test pit completed at at depth of 12.5 feet on 03/27/03
 Slow groundwater seepage observed at a depth of 11.75 feet
 Minor caving observed at depths between 0 and 3 feet

Note: See Figure A-1 for explanation of symbols

The depths of the test pit logs are based on an average of measurements across the test pit and should be considered accurate to 0.5 foot.

LOG OF TEST PIT 12



Project: Puyallup Retail Center
 Project Location: Puyallup, Washington
 Project Number: 3443-002-00

Figure: A-13
 Sheet 1 of 1

3443-002-00 GEI G1PIT_2.1.0_P:\313443002\09\FINALS\344300200TESTPITS.GPJ GEIV2 2.GDT 4/23/03

Date Excavated: 03/27/03

Logged by: EWB

Equipment: Case 580L Backhoe

Surface Elevation (ft): 464

Elevation feet	Depth feet	Sample Number	Water	Graphic Log	Group Symbol	MATERIAL DESCRIPTION	Water Content, %	Dry Unit Weight, lbs/ft ³	OTHER TESTS AND NOTES
0					DUF	6-inch forest duff			
					SM	Brown-reddish brown silty sand with roots (loose, moist)			
					GP-GM	Gray fine to coarse gravel with sand and silt, occasional sand and cobbles (dense, moist)			
460	1	1							
	5								
455	10								
						Test pit completed at at depth of 10.5 feet on 03/27/03 Moderate groundwater seepage observed at a depth of 5.5 feet Moderate caving observed at depths between 1 and 2 feet			
450	15								
445	20								

Note: See Figure A-1 for explanation of symbols
The depths of the test pit logs are based on an average of measurements across the test pit and should be considered accurate to 0.5 foot.

LOG OF TEST PIT 13



Project: Puyallup Retail Center
Project Location: Puyallup, Washington
Project Number: 3443-002-00

Figure: A-14
Sheet 1 of 1

3443-002-00 GEL GT 1.0 P:\3\3443002\00\FINALS\344300200TESTPITS.GPJ GEV2 2.GDT 4/23/03

Date Excavated: 03/27/03

Logged by: EWH

Equipment: Case 580L Backhoe

Surface Elevation (ft): 460

Elevation feet	Depth feet	Sample Number	Water	Graphic Log	Group Symbol	MATERIAL DESCRIPTION	Water Content, %	Dry Unit Weight, lbs/ft ³	OTHER TESTS AND NOTES
460	0				DUF	3- to 6-inch forest duff			
					SM	Brown silty sand with gravel (loose, moist)			
		1			GP	Gray fine to coarse gravel with sand, trace silt (dense, wet)			
455	5								
450	10								
						Test pit completed at at depth of 10 feet on 03/27/03 Rapid groundwater seepage observed at a depth of 5 feet Slight caving observed at depths between 1 and 3 feet			
445	15								
440	20								

Note: See Figure A-1 for explanation of symbols
The depths of the test pit logs are based on an average of measurements across the test pit and should be considered accurate to 0.5 foot.

LOG OF TEST PIT 14



Project: Puyallup Retail Center
Project Location: Puyallup, Washington
Project Number: 3443-002-00

Figure: A-15
Sheet 1 of 1

3443-002-00 GEI G11-SPIT 2.1.0 P:\3443002\00\FINAL\3443002007TESTPITS.GPJ GEIV2, 2.GDI 4/23/03

Date Excavated: 03/27/03

Logged by: EWB

Equipment: Case 580L Backhoe

Surface Elevation (ft): 467

Elevation feet	Depth feet	Sample Number	Water	Graphic Log	Group Symbol	MATERIAL DESCRIPTION	Water Content, %	Dry Unit Weight, lbs/ft ³	OTHER TESTS AND NOTES
0					SOD	6-inch grass and sod			
					SM	Brown silty sand with gravel, trace roots (loose, moist)			
465		1			GP	Gray fine to coarse gravel with sand, trace silt (medium dense, moist)			
	5								
460									
	10								
455						Test pit completed at at depth of 10 feet on 03/27/03 Minor groundwater seepage observed at a depth of 6 feet Severe caving observed at depths between 2 and 10 feet			
	15								
450									
	20								

Note: See Figure A-1 for explanation of symbols
The depths of the test pit logs are based on an average of measurements across the test pit and should be considered accurate to 0.5 foot.

LOG OF TEST PIT 15



Project: Puyallup Retail Center
Project Location: Puyallup, Washington
Project Number: 3443-002-00

Figure: A-16
Sheet 1 of 1

3443-002-00 GEL.GT.15.PIT.2.1.D.P:\3134\3002\00\FINAL\344300200TESTPITS.GPJ GENV2.2.GDT 4/23/03

Date Excavated: 03/31/03

Logged by: KWG

Equipment: Case 580L Backhoe

Surface Elevation (ft): 468

Elevation feet	Depth feet	Sample Number	Water	Graphic Log	Group Symbol	MATERIAL DESCRIPTION	Water Content, %	Dry Unit Weight, lbs/ft ³	OTHER TESTS AND NOTES
0					DUF	2- to 4-inch forest duff			
		1			SP-SM	Reddish brown fine sand with silt, occasional gravel (medium dense, moist)			
		2			GP	Gray fine to coarse gravel with sand, trace silt (dense, moist)			
465					SP	Gray fine to medium sand, trace silt and granite cobbles (dense, moist)			
		3							
5									
		4			SM	Gray silty fine sand (very dense, moist)			
460									
						Test pit completed at at depth of 8 feet on 03/31/03 No groundwater seepage observed No caving observed			
10									
455									
15									
450									
20									

Note: See Figure A-1 for explanation of symbols

The depths of the test pit logs are based on an average of measurements across the test pit and should be considered accurate to 0.5 foot.

LOG OF TEST PIT 24



Project: Puyallup Retail Center
 Project Location: Puyallup, Washington
 Project Number: 3443-002-00

Figure: A-25
 Sheet 1 of 1

PIT_2.1.0_P\3394\3302\00\FINAL\344300200TESTPITS.GPJ GEI\2.GDT 4/23/03

3443-002-00 GEI

Date Excavated: 03/31/03

Logged by: K.W.G

Equipment: Case 580L Backhoe

Surface Elevation (ft): 462

Elevation feet	Depth feet	Sample Number	Water	Graphic Log	Group Symbol	MATERIAL DESCRIPTION	Water Content, %	Dry Unit Weight, lbs/ft ³	OTHER TESTS AND NOTES
0					DUP	2- to 4-inch forest duff			
					SM	Reddish brown silty fine to medium sand, trace gravel (medium dense, moist)			
460		1	▼		SM	Reddish gray silty fine sand (dense, wet)	22		%F = 15.7 Sieve Analysis
					GP	Gray fine to coarse gravel with sand, trace silt (dense, wet)			
455		2							
						Test pit completed at at depth of 8 feet on 03/31/03 Rapid groundwater seepage observed at a depth of 2 feet Minor caving observed at depths between 2 and 4 feet			
450									
445									
20									

Note: See Figure A-1 for explanation of symbols

The depths of the test pit logs are based on an average of measurements across the test pit and should be considered accurate to 0.5 foot.

.TPIT_2.1.0 P:\34343002\03\FINAL\344300200TESTPITS.GPJ GEIV2_2.GDT 4/23/03

3443-002-00 GEI

LOG OF TEST PIT 26



Project: Puyallup Retail Center
 Project Location: Puyallup, Washington
 Project Number: 3443-002-00

Figure: A-27
 Sheet 1 of 1