

**City of Puyallup  
Building  
REVIEWED  
FOR  
COMPLIANCE**

BSnowden  
09/11/2024  
9:34:48 AM

Front View - Scale: 3/8" = 1'

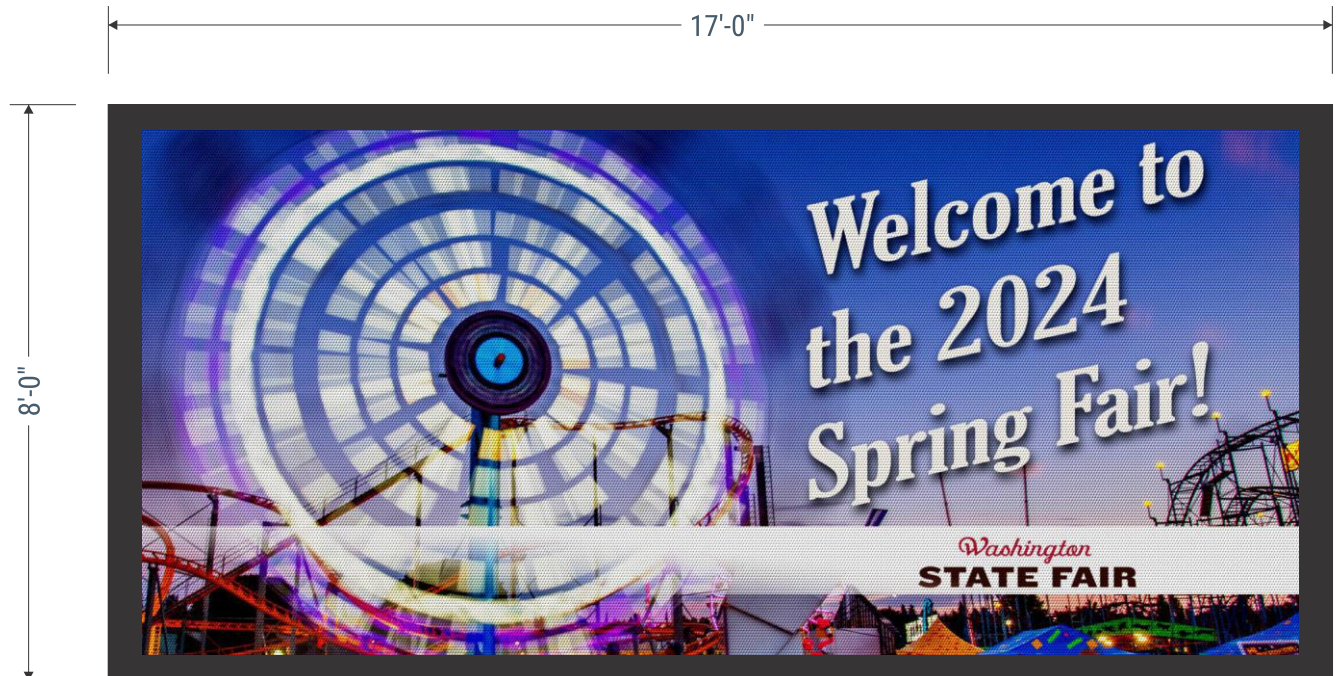
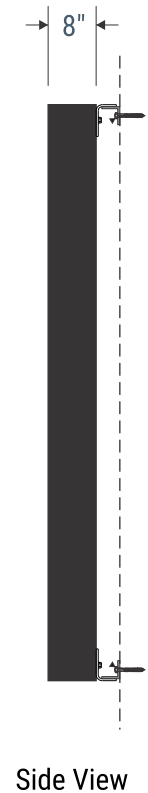

Side View

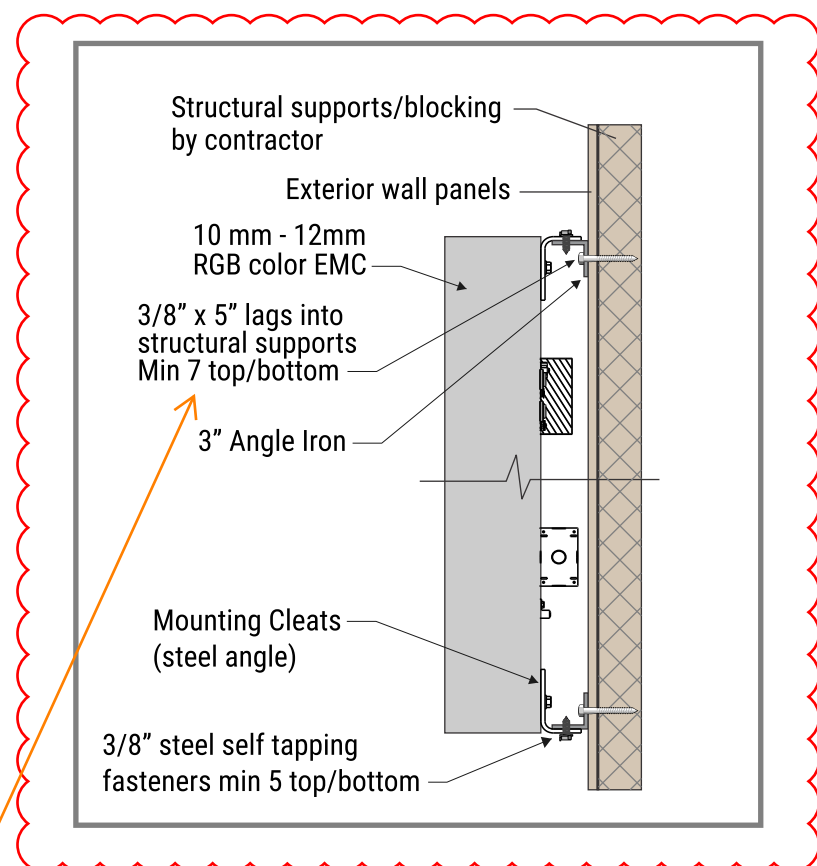

8.26.2024

Prior to installation:  
Review anchor product's ESR and install the product per the report. If special inspection(s) are required - the final special inspection report must be on site during City inspections.

**City of Puyallup  
Development & Permitting Services  
ISSUED PERMIT**

Building	Planning
Engineering	Public Works
Fire	Traffic

Separate Electrical Permit is required with the Washington State Department of Labor & Industries.  
<https://lni.wa.gov/licensing-permits/electrical/electrical-permits-fees-and-inspections>  
or call for Licensing Information: 1-800-647-0982

3/8" x 5" lags into structural supports Min 7 top/bottom

Approval of submitted plans is not an approval of omissions or oversights by this office or non compliance with any applicable regulations of local government. The contractor is responsible for making sure that the building complies with all applicable codes and regulations of the local government.

The approved construction plans, documents, and all engineering must be posted on the job at all inspections in a visible and readily accessible location.

Full sized legible color plans are required to be provided by the permittee on site for inspection.

**APPROVED PLAN  
CITY OF PUYALLUP  
PLANNING DIVISION**

APPROVED BY: ARamirez  
DATE: 08/12/2024  
CASE NO.: **PRSG20241248**  
CONDITIONS:

**1 WALL MOUNTED RGB ELECTRONIC MESSAGE CENTER - QTY: 1**

Remove 2 existing freestanding structures (By client)  
Mount EMC to Wall using Mounting cleats and angle iron, angle is attached to wall and EMC has mounting cleats at back  
EMC to be 10mm-12mm RGB (color) display

**136 Sq. Ft.  
Sign weight: 1569#**

8.26.2024

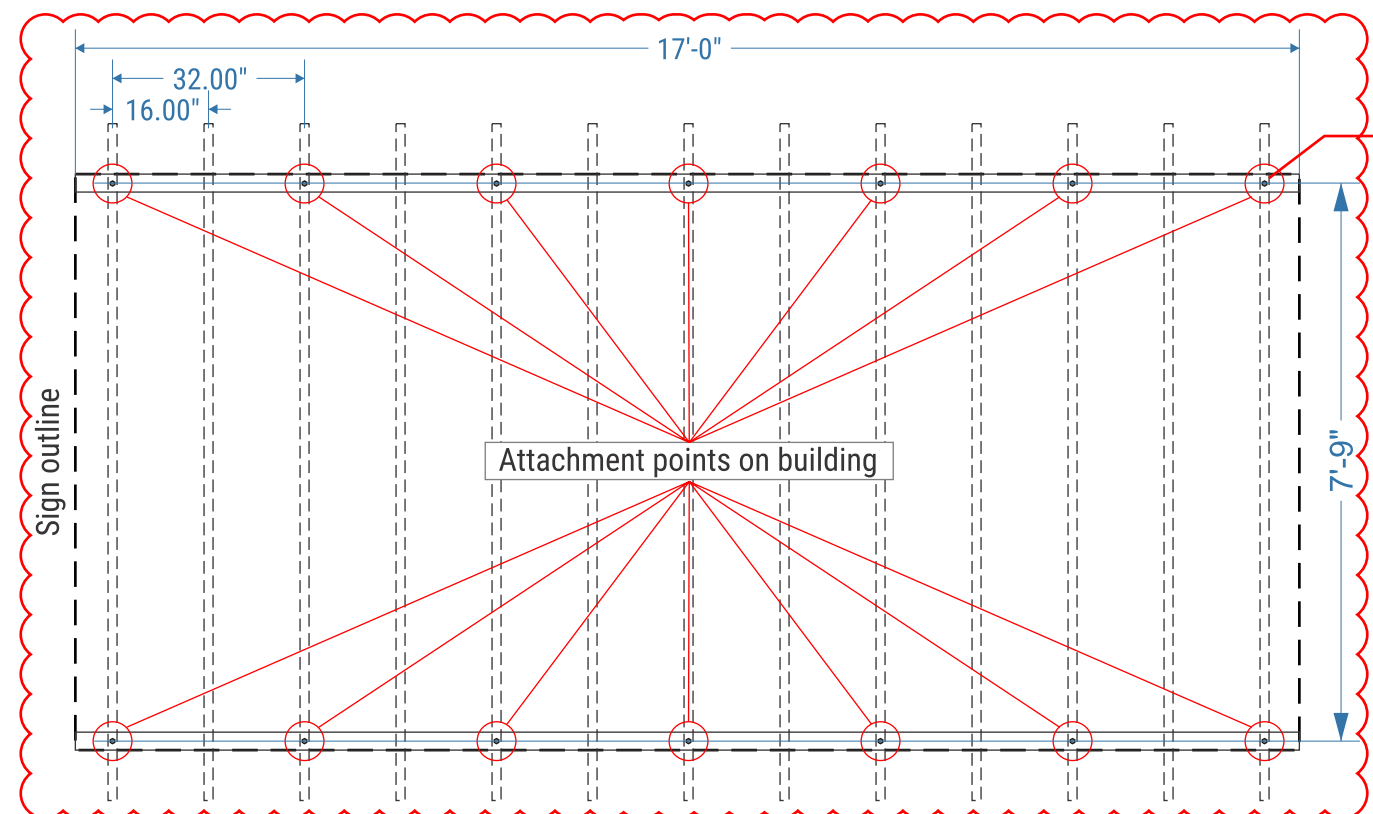

8.26.2024

City of Puyallup Development & Permitting Services ISSUED PERMIT	
Building	Planning
Engineering	Public Works
Fire	Traffic

EXISTING FREESTANDING STRUCTURES  
REMOVED BY CLIENT



Proposed Sign Location | Zoom View | Scale: 3/32" = 1'



Existing Condition | Scale: NTS

**NOTE: EXISTING FREESTANDING  
STRUCTURES REMOVED BY CLIENT**

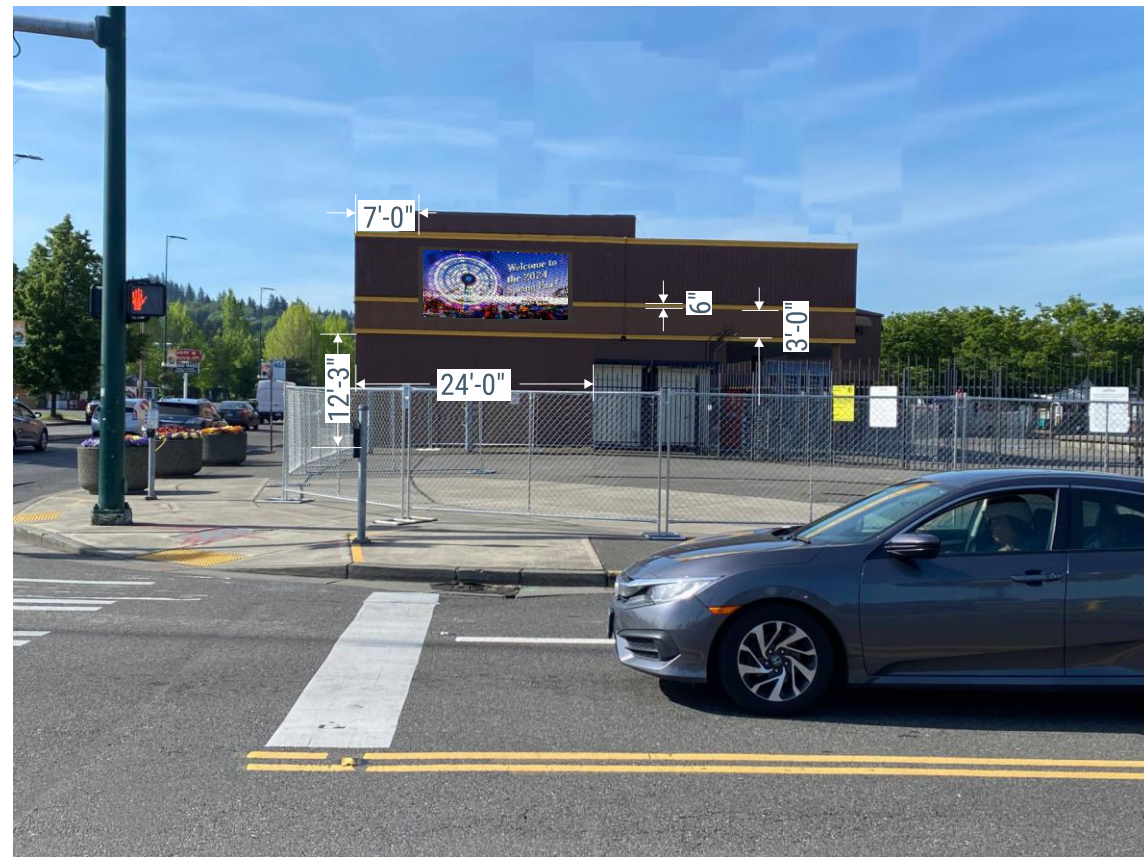

Proposed Sign Location | Zoom out View | Scale: 1 1/2"/32" = 1'

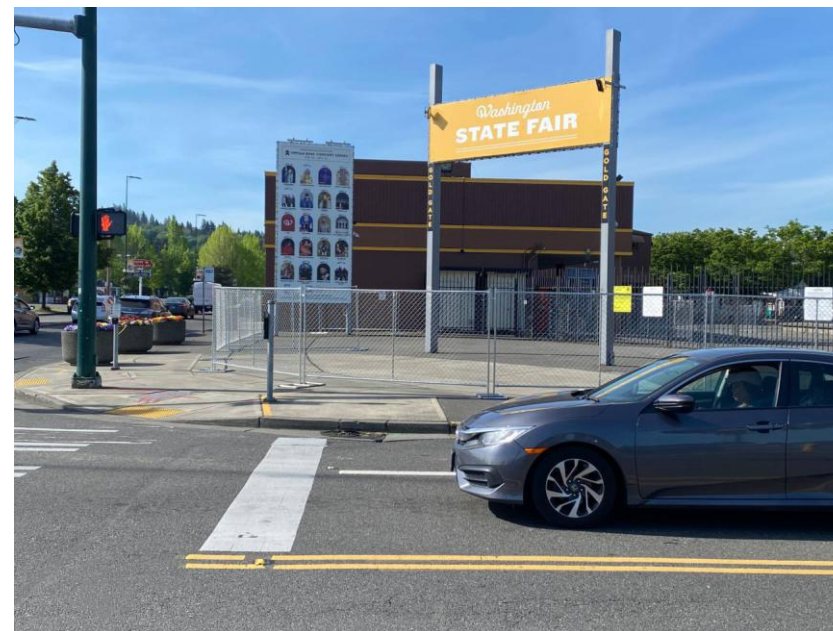

Existing Condition | Scale: NTS



PRSG20241248

City of Puyallup Development & Permitting Services ISSUED PERMIT	
Building	Planning
Engineering	Public Works
Fire	Traffic

Site Plan



Scale: 1"=50'