



# Fire Systems West, Inc.

206 FRONTAGE ROAD NORTH, SUITE C  
PACIFIC, WA 98047  
(253) 833-1248



## **FIRE ALARM Equipment Submittal**

FOR  
**McDonald's**  
**304 2<sup>nd</sup> Street NE**  
**Puyallup, WA 98372**

# GWF-7075

## Intelligent Fire Alarm Control Panel

### General

The Gamewell-FCI®, GWF-7075 is an Addressable Fire Alarm Control Panel (FACP). The GWF-7075 has a signaling line circuit (SLC) loop that is used to connect the addressable detectors. The SLC loop is capable of supporting up to 75 detectors and 75 modules using the System Sensor® Velociti® Protocol, and it also offers the built-in support for the SWIFT™ wireless fire alarm devices.

The GWF-7075 is equipped with two configurable Notification Appliance Circuits (NACs) that support a maximum output of 2.5A. This panel communicates with the built-in, dual-line digital and IP communicator including an optional cellular communication module.

The GWF-7075 fire alarm control panel offers the following powerful features:

- detector sensitivity
- day/night thresholds
- drift compensation
- pre-trouble maintenance alert
- calibration trouble alert

The GWF-7075 panel supports a variety of devices, including the following accessories:

- RA-1000 Remote Annunciator
- 5880 - LED I/O Module
- GFPS-6S Intelligent Remote Power Supply
- 5824 Serial/Parallel Printer Interface Module (for printing system reports)



GWF-7075

## FEATURES & BENEFITS

- |   |   |   |  |   |
|---|---|---|--|---|
| <ul style="list-style-type: none"> <li>• Built-in support for up to 75 detectors and 75 modules operating in Velociti® mode</li> <li>• Offers a four line LCD display with 40 characters per line</li> <li>• Available in a red or a black cabinet</li> <li>• GWF-7075 can be surface or flush mounted</li> </ul> | <ul style="list-style-type: none"> <li>• Contains a built-in USB interface used for programming</li> <li>• Includes the programmable date setting for Daylight Saving Time</li> <li>• Uses a JumpStart Auto Programming® feature for easy programming</li> <li>• Reports events to the Central Station by point or by zone</li> </ul> | <ul style="list-style-type: none"> <li>• System programmable from the front panel</li> <li>• Provides a built-in dual phone line, digital alarm communicator/transmitter (DACT), IP or optional cellular technologies</li> <li>• Firmware can be upgraded in the field</li> </ul> | <ul style="list-style-type: none"> <li>• Supports up to four SWIFT™ wireless gateways. Each gateway may include up to 49 wireless devices</li> <li>• Supports Class B (Style 4) and Class A (Style 6 or Style 7 configuration for SLC, and SBUS</li> </ul> | <ul style="list-style-type: none"> <li>• Offers a built-in synchronization for some models,</li> </ul> <p>Note: To identify the compatible models, refer to the Compatibility Addendum to Gamewell-FCI Manuals, P/N:9000-0427-L8.</p> |
|---|---|---|--|---|

## Optional Accessories

### RA-1000: Remote Annunciator

The RA-1000 is a remote annunciator used to operate the GWF-7075 Fire Alarm Control Panel (FACP). It connects to the control panel via the RS-485 system bus. The RA-1000 is equipped with five status LEDs which indicate:

- Alarm
- System Silenced
- Supervisory
- AC Power Loss
- Trouble

### GFPS-6S: Intelligent Remote Power Supply

The GFPS-6S intelligent power supply delivers 6A of Notification Appliance Circuit (NAC) power and offers built-in synchronization for some appliances developed by the following manufacturers.

- System Sensor®
- Gentex®
- Wheelock™
- Faraday™
- AMSECO™

**Note: Sync Feature Restriction:** Not all devices can use the Sync Feature. To ensure that the selected device works with the Sync Feature, refer to the Compatibility Addendum to Gamewell-FCI Manuals, P/N: 9000-0427-L8.

The GFPS-6S provides its own AC power connection, battery charging circuit, and backup battery for use with the GWF-7075 FACP. The output circuits can be programmed as NACs or as auxiliary power (configurable for constant, resettable, or door holder power).

### 5824: Serial / Parallel Module

The 5824 is equipped with one parallel and one RS-232 serial port that allows the GWF-7075 to connect to virtually any standard PC-compatible printer to generate reports on site.

### 5880: LED I/O Module

The 5880 provides 40 programmable LED outputs and eight supervised dry contact inputs. These devices offer an effective way to customize remote annunciation. The GWF-7075 supports up to eight 5880 modules to offer maximum flexibility.

### 5220: Direct Connect Module

The 5220 is a direct connect module used to connect a fire alarm control panel (FACP) to a city box or polarity reversal communicator.

## COMPATIBLE DEVICES

For a list of compatible devices, refer to the following documents:

- Compatibility Addendum for Gamewell-FCI Manuals, P/N: 9000-0427-L8
- SWIFT™ Intelligent Wireless Detectors, P/N: 9021-60818
- SWIFT™ Intelligent Wireless Modules, P/N: 9021-60819
- SWIFT™ Wireless Gateway, P/N: 9021-60824

## ORDERING INFORMATION

**GWF-7075:** Intelligent Fire Alarm Control Panel, Red

**GWF-7075B:** Intelligent Fire Alarm Control Panel, Black

### SBUS Accessories

**RA-1000:** Remote Annunciator (Black)

**Dimensions:** 7.4"H x 9.1"W x 1.5"  
(18.8 x 23.1 x 3.8) cm

**RA-1000R:** Remote Annunciator (Red)

**GFPS-6S:** Intelligent Remote Power Supply

**Dimensions:** 16"H x 12.25"W x 3"D  
(40.6 x 30.9 x 7.6) cm

**5824:** Serial / Parallel Module

**Dimensions:** 6"H x 7.75"W x 1.44"D  
(15.0 x 19.4 x 3.6) cm

**5880:** LED I/O Module

**Dimensions:** 7.75"H x 6"W x 1.94"D  
(19.4 x 15.0 x 4.8) cm

**5220:** Direct Connect Module

**Dimensions:** 1.31"H x 6.5"W x 2.13"D  
(3.33 x 16.51 x 5.40)cm

### Miscellaneous Accessories

**HFSS:** Software Suite. Provides programming, upload/download and event reporting

**BB-17F:** Remote Battery Box Cabinet. Holds up to two 18 Amp Hour batteries.

**Dimensions:** 16" W x 10" H x 6" D  
(40.64 W x 25.40 H x 15.24 D) cm

# GWF-7075 Technical Specifications

## SYSTEMS

### PHYSICAL:

**Overall Dimensions:** 15.12" H x 12.71" W x 3.33" D  
38.40 H x 32.28 W x 8.46 D cm

**Weight:** 25 lbs.

**Color:** Red or Black

**Environmental Operating Temperature:** 32°F to 120°F  
(0°C to 49°C)

**Humidity:** 0 to 93% relative humidity  
(non-condensing)

### ELECTRICAL:

**GWF-7075 Primary AC:** 120 VAC @ 60 Hz,  
900mA Total

**Accessory Load:** 2.5A @ 27.4 VDC Class A  
Power-Limited

**NAC Power:** 1A per NAC, 2.5A Total

**Aux Power:** 27.4 VDC

**Form C Trouble & Alarm Relay:** 2.5A @ 27.4 VDC,  
Resistive

**Standby Current:** 165 mA

**Alarm Current:** 310 mA

**Battery Charging Capacity:** 7 to 35 AH

**Battery Size:** 7 A/H maximum allowed in the control panel cabinet. Larger capacity batteries can be housed in the BB-17F accessory cabinet.

### TEMPERATURE AND HUMIDITY RANGES

This system meets NFPA requirements for operation at 0 – 49°C/32 – 120°F and at a relative humidity 93% ± 2% RH (noncondensing) at 32°C ± 2°C (90°F ± 3°F).

However, the useful life of the system's standby batteries and the electronic components may be adversely affected by extreme temperature ranges and humidity. Therefore, it is recommended that this system and its peripherals be installed in an environment with a normal room temperature of 15 – 27°C/60 – 80°F.

## STANDARDS

The GWF-7075 is designed to comply with the following standard:

**UL Standard:** UL 864 9th Edition

### NFPA STANDARDS

NFPA 13 Sprinkler

NFPA 15 Water Spray

NFPA 16 Foam Water

NFPA 70

NFPA 72

Central Station

Remote Signaling

Local Protective Signaling Systems

Auxiliary Protected Premises Unit & Water Deluge Releasing Service

### AGENCY LISTINGS AND APPROVALS

These listings and approvals apply to the modules specified in this document. In some cases, certain modules or applications may not be listed by certain approval agencies, or listing may be in process. Consult factory for latest listing status.

**UL:** S1869

**CSFM:** 7165-1703:0500

**FDNY:** COA-6255

**OSHPD (CA)**

**Approved Releasing Solenoids:**

Asco® T8210A107 24 VDC 3 A max. 0 Hz

Asco® 8210G207 24 VDC 3 A max. 0 Hz

**ISO 9001 Certification**

For a complete listing of all compliance approvals and certifications, please visit: <http://www.gamewell-fci.com/en-US/documentation/Pages/Listings.aspx>

Gamewell-FCI®, System Sensor® and Velociti® are registered trademarks and SWIFT™ is a trademark of Honeywell International, Inc.

AMSECO™ is a registered trademark of Kobishi America Inc.

Asco® is a registered trademark of Asco Power Technologies Inc.

Farraday™ is a trademark of Faraday LLC.

Gentex® is a registered trademark of Gentex Corporation Inc.

Microsoft, Windows®, and the Windows Logo® are registered trademarks or trademarks of Microsoft Corporation.

UL® is a registered trademark of Underwriter's Laboratories Inc.

Wheelock™ is a trademark of Cooper-Wheelock Inc.

This document is not intended to be used for installation purposes. We try to keep our product information up-to-date and accurate. We cannot cover all specific applications or anticipate all requirements. All specifications are subject to change without notice.

## For more information

Learn more about Gamewell-FCI's GWF-7075 and other products available by visiting [www.Gamewell-FCI.com](http://www.Gamewell-FCI.com)

## Honeywell Gamewell-FCI

12 Clintonville Road  
Northford, CT 06472-1610  
203.484.7161  
[www.honeywell.com](http://www.honeywell.com)

# Velociti® Series 3 Detectors

## Photoelectric Detectors

### Description

The Gamewell-FCI, Velociti® Series 3 intelligent photoelectric detectors with integral communication provide point location for alarm communication and selective maintenance. Designed in a modern bright white color, the Velociti Series 3 is aesthetically pleasing for today's contemporary buildings.

The Velociti Series 3 smoke detectors are intelligent addressable detectors with point ID capability that enable each detector address to be set with rotary address switches providing exact device locations. The photoelectric detector continually monitors the detected temperature and reports it to the fire alarm control panel. The modern design and expanded color options support a variety of contemporary aesthetic demands. In addition, each detector is constructed for exceptional installation and maintenance efficiency.

The Gamewell-FCI, ASD-PL3 photoelectric detector's re-designed optical sensing chamber is engineered to sense smoke produced by a wide range of combustion sources in accordance with more stringent code standards. The sensitivity of Velociti series detectors can be programmed using the control panel software to suit the environment. The ASD-PL3R photoelectric detector is also remote test capable that may be used with a DNR (DNRW) duct smoke detector housing. The ASD-PTL3 multi-sensor detector offers either photoelectric detection or thermal detection through dual electronic thermistors at 135°F fixed temperature thermal sensing.

For legacy installations, service detectors are available in the classic ivory color that will operate in both Velociti and CLIP protocol for backwards compatibility. Service models are designated by the -IV part number after the detector model.

**Note:** Although the E3 Series® and S3 Series panels support both the Velociti® and CLIP™ protocols, the GWF-7075 panel does not support the CLIP protocol. To obtain a complete list of panels that are listed to Velociti Series 3 detectors, refer to the Compatibility Addendum for Gamewell-FCI Manuals, P/N:9000-0427-L8.



Photoelectric Detector

## FEATURES & BENEFITS

- Complies with UL® Standard 268 7th Edition
- Contains a built-in functional test switch activated by external magnet
- Provides rotary address switches (01-159)
- Includes dual LEDs for 360° visibility
- Offers expanded color options
- Designed with a new profile to offer modern and improved aesthetics
- Supports a low standby current
- Supplies optional relay, isolator, or sounder bases (standard or low frequency)

## Ordering Information

**NOTE:** "-IV" suffix indicates Ivory color model.

**NOTE:** "-BL" suffix indicates Black color model.

**NOTE:** "WH" suffix indicates Bright White color model.

**ASD-PL3:** Photoelectric smoke detector, bright white, Velociti

**ASD-PL3R:** Photoelectric smoke detector, remote test capable, for use with DNR(W) duct smoke detectors, bright white, Velociti

**ASD-PTL3:** Photoelectric smoke detector with thermal sensing, bright white, Velociti

**ASD-PL3-IV :** Photoelectric smoke detector, ivory, Velociti/CLIP

**ASD-PL3R-IV:** Photoelectric smoke detector, remote test capable, for use with DNR(W) duct smoke detectors, ivory, Velociti/CLIP

**ASD-PTL3-IV :** Photoelectric smoke detector with thermal sensing, ivory, Velociti/CLIP

### Intelligent Bases

For details on intelligent bases, refer to Data Sheet P/N: 9021-60540.

**Note:** "IV" suffix indicates Flashscan and CLIP devices. "WH" suffix indicates bright white

**B501-WHITE:** 4" Flangeless mounting base, bright white

**B501-WHITE-BP:** 4" Flangeless mounting base bulk pack, bright white

**B501-IV:** 4" Flangeless mounting base, ivory

**B300-6:** 6" Flanged mounting base, bright white

**B300-6-IV:** 6" Flanged mounting base, ivory

**B300-6-BP:** 6" Flanged mounting base bulk (Pack of 10)

**B200SR-WH:** Standard sounder base, bright white

**B200SR-IV:** Standard sounder base, ivory

**B200S-WH:** Intelligent addressable sounder base, bright white

**B200S-IV:** Intelligent addressable sounder base, ivory

**B200SR-LF-WH:** Standard low frequency sounder base, bright white

**B200SR-LF-IV:** Standard low frequency sounder base, ivory

**B200S-LF-WH:** Intelligent addressable low frequency sounder base, bright white

**B200S-LF-IV:** Intelligent addressable low frequency sounder base, ivory

**B224RB-WH:** Relay base, bright white

**B224RB-IV:** Relay base, ivory

**B224BI-WH:** Isolator base, bright white

**B224BI-IV:** Isolator base, ivory

**DNR:** Intelligent duct detector housing, non-relay

**DNRW:** Intelligent duct detector housing, non-relay, watertight

## Ordering Information

### Accessories

**SMB600:** Surface Mounting Kit (flanged)

**TR300:** Accessory Flange Ring for B300 6" Base, bright white

**TR300-IV:** Accessory Flange Ring for B300 6" Base, ivory

**RA100Z:** Remote LED annunciator, 3-32 VDC

The annunciator mounts to a U.S. single-gang electrical box. For use with B501 and B300-6.

**CK300:** Bright White detector kit (Pack of 10)

**CK300-IR:** White, detector color kit for use with MCS-COF Series Detectors. (Pack of 10)

**CK300-IV:** Ivory, detector color kit. (Pack of 10)

**CK300-IR-IV:** Ivory, detector color kit for use with MCS-COF Series detectors. (Pack of 10)

**CK300-BL:** Black detector kit. (Pack of 10)

**CK300-IR-BI:** Black, detector color kit for use with MCS-COF Series detectors. (Pack of 10)

**M02-04-01:** Detector test magnet.

**M02-09-00:** Test magnet with telescoping handle.

**XR2B:** Detector removal tool. Allows the installation and/or removal of the detector heads from the bases in high ceiling applications.

**XP-4:** Extension pole for XR2B. Shipped with three, 5-foot (1.524,m) sections.

# Velociti® Series 3 Detectors Technical Specifications

## SYSTEMS

**Photoelectric Intelligent Detector:**

### Physical Specifications

**Height:** 2.0 inches (51 mm) installed in B300-6 base

### Diameter:

6.1 inches (15.49 cm) installed in B300-6 base

4 inches (10.16 cm) installed in B501 base

**Shipping Weight:** 3.4 oz (96.4 g)

### Operating Temperature Range:

**Photo:** 32° F to 122° F (0° C to 50° C)

**Photo in Duct Applications:** -4° F to 158° F  
(-20° C to 70° C)

**Photo with Thermal:** 32° F to 100° F (0° C to 38° C)

**Operating Humidity Range:** 10% to 93%  
non-condensing

**Rate-of-Rise Detection:** Responds to greater than  
15°F/minute or 135°F (8.3° C/minute or 57°C)

**Air Velocity Range:** 0 to 4,000 ft/min  
(0 to 1219.2 m/min)

### Electrical Specifications

**Voltage Range:** 15 to 32 VDC

**Standby Current (@ 24 VDC):** 200 UA (one  
communication every 5 seconds with green LED  
enabled)

**Max Alarm Current (max.):** 2 mA @ 24 VDC (one  
communication every 5 seconds with red LED  
enabled)

**Max Current (max.):** 4.5 mA @ 24 VDC (one  
communication every 5 seconds with amber LED  
enabled)

**Isolator Load Rating:** 0.0063

## STANDARDS

The Velociti® Series 3 Photoelectric Detectors are designed to comply with the following standard:

**UL Standard:** UL 268

## AGENCY LISTINGS AND APPROVALS

These listings and approvals apply to the modules specified in this document. In some cases, certain modules or applications may not be listed by certain approval agencies, or listing may be in process. Consult factory for latest listing status.

**UL:** S2332

**FM:** 3023594

**MEA FDNY:** COA-219-02-E Vol. VI

**CSFM:** 7272-1703:0501

**ISO 9001 Certification**

For a complete listing of all compliance approvals and certifications, please visit:  
<http://www.gamewell-fci.com/en-US/documentation/Pages/Listings.aspx>

E3 Series®, Velociti® and Gamewell-FCI® are registered trademarks of Honeywell International Inc.

UL® is a registered trademark of Underwriter's Laboratories Inc.

This document is not intended to be used for installation purposes. We try to keep our product information up-to-date and accurate. We cannot cover all specific applications or anticipate all requirements. All specifications are subject to change without notice.

## For more information

Learn more about Gamewell-FCI's Velociti® Series 3 Detectors and other products available by visiting [www.Gamewell-FCI.com](http://www.Gamewell-FCI.com)

## Honeywell Gamewell-FCI

12 Clintonville Road  
Northford, CT 06472-1610  
203.484.7161  
[www.honeywell.com](http://www.honeywell.com)

9020-0617 | K | 04/2018  
©2018 Honeywell International Inc.

**Honeywell**

# Velociti® Series AMM-2IF

## Addressable Dual Monitor Module

### General

The Gamewell-FCI Velociti® Series, addressable dual monitor module, AMM-2IF, features two Style B, Class B initiating device circuits, each with an end-of-line resistor. This module provides addresses for any device or group of devices connected to each circuit. Any alarm initiating devices with normally open (N.O.) dry contacts, such as heat detectors, 4-wire projected beam smoke detectors, 4-wire smoke detectors, water flow switches, tamper switches, manual stations, etc. may be installed in these circuits.

The Velociti® Series use a communication protocol that substantially increases the speed of communication between the sensors and certain Gamewell-FCI analog addressable fire alarm controls. These devices operate in a grouped fashion. If one of the devices in the group has a status change, the panel's microprocessor stops the group poll and concentrates on the single device. The net effect is response speed up to five times greater than earlier designs.

The first circuit address is set via a rotary switch. The second circuit is automatically assigned the next higher address. The module has a single panel-controlled red LED.

The AMM-2IF module is designed for installation in the signaling line circuit of any Gamewell-FCI addressable control panel. The AMM-2IF is designed to mount in a 4" square junction box, 2 1/8" deep. The initiating device circuit of the AMM-2IF can support a maximum line resistance of up to 40 ohms allowing the use of linear heat detection devices.

### Ordering Information

**AMM-2IF:** Monitor module, two circuit, Style B, Class B



AMM-2IF

## FEATURES & BENEFITS

- Supports Class B, Style B, initiating device circuits
- Provides a visual rotary, decimal switch addressing (01-159)
- Offers 40 ohm line resistance for each initiating circuit
- Accommodates any normally open contact device
- Displays bi-color LEDs flash green whenever the module is addressed, and light steady red on alarm\*
- Includes a compact size allows easy installation

\*Note: Only the red LED is operative in panels that do not operate in Velociti® mode.



# Velociti® Series AMM-2IF Technical Specifications

## SYSTEMS

**Supervisory Current:** .00075 amps

**Alarm Current:** .00097 amps (LED lit)

**Operating Temperature:** 32° to 120° F (0° to 49° C)

**Relative Humidity:** 10 to 93% (non-condensing)

**Dimensions:** 4 1/2" H x 4" mW x 1 1/4" D  
(11 H x 10.2 W x 3 D cm)

(Mounts in a 4" square by 2 1/8" deep box).

**End-of-line Resistor:** 47 K ohms

## TEMPERATURE AND HUMIDITY RANGES

This system meets NFPA requirements for operation at 0 – 49°C/32 – 120°F and at a relative humidity 93% ± 2% RH (noncondensing) at 32°C ± 2°C (90°F ± 3°F).

However, the useful life of the system's standby batteries and the electronic components may be adversely affected by extreme temperature ranges and humidity. Therefore, it is recommended that this system and its peripherals be installed in an environment with a normal room temperature of 15 – 27°C/60 – 80°F.

## STANDARDS

The Velociti® Series AMM-2IF is designed to comply with the following standards:

**UL Standards:** UL 864 9th Edition

UL 2572 for Mass Notification

## AGENCY LISTINGS AND APPROVALS

These listings and approvals apply to the modules specified in this document. In some cases, certain modules or applications may not be listed by certain approval agencies, or listing may be in process. Consult factory for latest listing status.

**UL:** S1949

2572 for Mass Notification

**FM:** 3023594

**MEA FDNY:** 227-03-E Vol. IV

**CSFM:** 7300-1703:0107

**ISO 9001 Certification**

For a complete listing of all compliance approvals and certifications, please visit: <http://www.gamewell-fci.com/en-US/documentation/Pages/Listings.aspx>

Velociti®, E3 Series® and Gamewell-FCI are registered trademarks of Honeywell International Inc.

This document is not intended to be used for installation purposes. We try to keep our product information up-to-date and accurate. We cannot cover all specific applications or anticipate all requirements. All specifications are subject to change without notice.

## For more information

Learn more about Gamewell-FCI's Velociti® Series AMM-2IF and other products available by visiting [www.Gamewell-FCI.com](http://www.Gamewell-FCI.com)

## Honeywell Gamewell-FCI

12 Clintonville Road  
Northford, CT 06472-1610  
203.484.7161  
[www.honeywell.com](http://www.honeywell.com)

9020-0629 | G | 01/20  
©2020 Honeywell International Inc.

**Honeywell**

## MS-7 Series

### Manual Fire Alarm Pull Stations

#### General

The Gamewell-FCI, MS-7 Series manual fire alarm pull stations are available in a wide variety of configurations. The pull stations comply with the Americans with Disabilities Act (ADA) 5-lb. maximum pull force requirement. Operating instructions and Braille text are engraved in the handle. All pull stations include a key lock/reset which is keyed alike with the Gamewell-FCI fire alarm control panels and other manual fire alarm pull stations.

#### MS-7AF Velociti Addressable Station

The MS-7AF Velociti® Series addressable station is a double action pull station designed for installation in the signaling line circuit of Gamewell-FCI analog addressable control panels. Activation of the pull station causes its assigned address to register at the fire alarm control panel. The door contains an LED which flashes green in normal condition and lights steady red when the station has been activated.\* The station features screw terminals.

#### MS-7ASF Velociti Addressable Station

The MS-7ASF Velociti® Series addressable pull station is a single action station designed for installation in the signaling line circuit of Gamewell-FCI analog addressable control panels. Activation of the station causes its assigned address to register at the control panel. The door contains an LED which flashes green in normal condition and lights steady red when the pull station is activated.\* The station features screw terminals.

The Velociti® Series pull stations use a communication protocol that substantially increases the speed of communication between the sensors and certain Gamewell-FCI analog addressable fire alarm controls. These devices operate in a grouped fashion. If one of the devices in the group has a status change, the panel's microprocessor stops the group poll and focuses on the single device. The net effect offers a response speed up to five times greater than earlier designs.

#### MS-7 Double Action Station

The MS-7 double action pull station is used with conventional fire alarm control panels. It features a set of single pole contacts and screw terminals for connection to an initiating circuit.

## FEATURES & BENEFITS

- Addressable stations compatible with all Gamewell-FCI analog addressable fire alarm controls
- Conventional stations suitable for use with any UL® Listed control panel
- The pull stations (MS-7LOB) are Listed for outdoor applications
- Complies with ADA pull force requirements
- Offers surface or semi-flush mounting
- Shock and vibration resistant
- Both single and double action pull stations available
- Includes a tumbler lock for test and reset keyed alike with analog addressable fire alarm controls
- \*Only the red LED is operative in panels that do not operate in Velociti mode



MS-7 Series

### MS-7S Single Action Station

The MS-7S single action pull station is used with conventional fire alarm control panels. It features a set of single pole contacts and wire leads for connection to an initiating circuit.

### MS-7SP Double Action Station

The MS-7SP is a double action pull station similar to the MS-7 station, with the additional feature of including both English and Spanish instructions molded into the unit.

### MS-7LR Dual-action Agent Release Station

The MS-7LR is designed for use with the Gamewell-FCI fire alarm control panels with releasing capabilities and Flex Series releasing systems. It features a set of single pole contacts and screw terminals used to connect to an initiating circuit.

### MS-7LRA Agent Release Station with Abort

The MS-7LRA is designed for use with the Gamewell-FCI fire alarm control panels with releasing capabilities and Flex Series releasing systems where system abort capabilities are required. It consists of the following:

- An MS-7LR mounted on a plate with an abort switch
- LED indicators that signal system normal and system activated status

### MS-7LOB Double Action Station (Listed for Outdoor Applications)

The MS-7LOB station must be mounted on a Model SB-I/O backbox. In retrofit applications, the pull station is UL Listed for use with the WP-10 backbox. It is intended for use with conventional control panels and has a set of single pole contacts and screw terminals.

### Mounting

The MS-7 interior pull stations may be surface mounted or semi-flush mounted on a standard double-gang, or 4-inch (10.2 cm) square electrical box. An optional trim ring (BG12TR) may also be used for semi-flush mounting.

### NYC-Plate

The NYC-Plate provides the backplate for the manual pull station. (See Figure 1).



Figure 1 NYC-Plate

### Ordering Information

**MS-7:** Double action station

**MS-7AF\*\*:** Velociti addressable double action station

**MS-7ASF\*\*:** Velociti addressable single action station

**MS-7S:** Single action station, wire leads

**MS-7SP:** Double action station, English and Spanish instructions

**MS-7LR:** Agent release station, dual-action

**MS-7LRA:** Agent release station with abort switch, LED indicators, dual- action

**MS-7LOB:** Double action station, outdoor use (Includes SB-I/O - Indoor/outdoor use backbox)

**SB-I/O:** Indoor/outdoor use backbackbox

**SB-10:** Surface backbox

**BG12TR:** Trim ring for semi-flush mount, plastic

**NY-PLATE:** NYC backplate for manual pull station

\*\*For use with the Gamewell-FCI analog addressable control panels only.

# MS-7 Series Technical Specifications

## SYSTEMS

**Material:** Lexan®

**Contact Ratings:** 0.25 amps. @ 30 VAC/VDC (resistive)

**Dimensions:** 5 5/8" H x 4 1/4" W x 1 1/4" D  
(14 x 10.1 x 3.2 cm)

### Operating Temperature:

(MS-7AF, MS-7ASF): 32° to 120° F (0° to 49° C)

(MS-7LOB): -30° to 150° F (-35° to 66° C)

### Relative Humidity :

(MS-7AF, MS-7ASF): 10 to 93% (non-condensing)

(MS-7LOB): 85% ± 5% @ 86° ± 3.6° (30° ± 2° C)

**Alarm Current:** .0030 amp. 0.007 for LED

### Supervisory Current:

(MS-7AF, MS-7ASF): .00030 amps.

## TEMPERATURE AND HUMIDITY RANGES

This system meets NFPA requirements for operation at 0 – 49°C/32 – 120°F and at a relative humidity 93% ± 2% RH (noncondensing) at 32°C ± 2°C (90°F ± 3°F).

However, the useful life of the system's standby batteries and the electronic components may be adversely affected by extreme temperature ranges and humidity. Therefore, it is recommended that this system and its peripherals be installed in an environment with a normal room temperature of 15 – 27°C/60 – 80°F.

## STANDARDS

The MS-7 Series is designed to comply with the following standard:

**UL Standard:** UL 864 9th Edition

## AGENCY LISTINGS AND APPROVALS

These listings and approvals apply to the modules specified in this document. In some cases, certain modules or applications may not be listed by certain approval agencies, or listing may be in process. Consult factory for latest listing status.

**UL:** S2465

**FM:** 3023594

**MEA FDNY:** 67-02-E Vol. VII

**CSFM:**

7160-1703:0119

7160-1703:0170

7160-1703:0109

**ISO 9001 Certification**

For a complete listing of all compliance approvals and certifications, please visit:

<http://www.gamewell-fci.com/en-US/documentation/Pages/Listings.aspx>

LEXAN® is a registered trademark of GE Plastics, a subsidiary of General Electric Company.

Velociti® and Gamewell-FCI are registered trademarks of Honeywell International Inc.

UL® is a registered trademark of Underwriter's Laboratories Inc.

This document is not intended to be used for installation purposes. We try to keep our product information up-to-date and accurate. We cannot cover all specific applications or anticipate all requirements. All specifications are subject to change without notice.

## For more information

Learn more about Gamewell-FCI's MS-7 Series and other products available by visiting [www.Gamewell-FCI.com](http://www.Gamewell-FCI.com)

## Honeywell Gamewell-FCI

12 Clintonville Road  
Northford, CT 06472-1610  
203.484.7161  
[www.honeywell.com](http://www.honeywell.com)

9020-0616 | F | 11/17  
©2017 Honeywell International Inc.

**Honeywell**



# Outdoor Selectable-Output Horns, Strobes, and Horn Strobes for Wall Applications



*SpectrAlert® Advance outdoor audible visible products are rich with features that cut installation times and maximize profits.*

## Features

- Weatherproof per NEMA 4X, IP56
- Listed to UL 1638 (strobe) and UL 464 (horn)
- Compatible with System Sensor synchronization protocol and legacy SpectrAlert products
- Field-selectable candela settings: 15, 15/75, 30, 75, 95, 110, 115, 135, 150, 177, and 185
- Automatic selection of 12- or 24-volt operation at 15 and 15/75 candela
- Rotary switch for horn tone and three volume selections
- Horn rated at 88+ dBA at 16 volts
- Rated from -40°F to 151°F
- Universal mounting plate with an onboard shorting spring that tests wiring continuity before devices are installed
- Plug-in design with minimal intrusion into the back box
- Tamper-resistant construction
- Listed for ceiling or wall mounting

**SpectrAlert Advance** offers the broadest line of outdoor horns, strobes, and horn strobes in the industry. With white or red plastic housings, wall or ceiling mounting options, and plain or FIRE-printed devices, SpectrAlert Advance can meet virtually any application requirement, including indoor, outdoor, wet, and dry applications in temperatures from -40°F to 151°F.

Like the entire SpectrAlert Advance line, outdoor horns, strobes, and horn strobes for wall applications include a variety of features that increase application flexibility and simplify installation. First, field-selectable settings, including candela, automatic selection of 12- or 24-volt operation, horn tones, and three volume options enable installers to easily adapt devices to meet requirements.

Next, SpectrAlert Advance devices use a universal mounting plate for both wall and ceiling applications. This mounting plate includes an onboard shorting spring that ensures wiring continuity before devices are installed, so installers can verify proper wiring without mounting the devices and exposing them to potential construction damage. Once the plates are mounted, all SpectrAlert Advance devices utilize a plug-in design with a single captured screw to speed installation and virtually eliminate costly ground faults.

Outdoor devices ship with weatherproof plastic back boxes (metal back boxes are available separately) that accommodate in-and-out wiring for daisy chaining devices. Plastic back boxes feature removable side flanges and improved resistance to saltwater corrosion. Knock-outs located on the back eliminate the need to drill holes for screw-in mounting. Plastic and metal weatherproof back boxes come with 3/4-inch top and bottom conduit entries and 3/4-inch knock-outs at the back. A screw-in NPT plug with an O-ring gasket for a watertight seal is included with each back box.

## Agency Listings



S4011 (chimes, horn strobes, horns)  
S3593 (outdoor and alert strobes)



3023572



MEA452-05-E



7300-1653-187 (outdoor strobes)  
7125-1653-188 (horn strobes,  
chime strobes)  
7135-1653-189 (horns, chimes)

# SpectrAlert Advance Outdoor Horn, Strobe, and Horn Strobe Specifications

## Architect/Engineer Specifications

### General

SpectrAlert Advance outdoor horns, strobes, and horn strobes shall mount to a weatherproof back box. A universal mounting plate shall be used for mounting ceiling and wall products. The notification appliance circuit wiring shall terminate at the universal mounting plate. Also, SpectrAlert Advance products, when used with the Sync•Circuit™ Module accessory, shall be powered from a non-coded notification appliance circuit output and shall operate on a nominal 12 or 24 volts. When used with the Sync•Circuit Module, 12-volt-rated notification appliance circuit outputs shall operate between 9 and 17.5 volts; 24-volt-rated notification appliance circuit outputs shall operate between 17 and 33 volts. Outdoor SpectrAlert Advance products shall operate between –40 and 151 degrees Fahrenheit from a regulated DC or full-wave rectified unfiltered power supply. Strobes and horn strobes shall have field-selectable candela settings including 15, 15/75, 30, 75, 95, 110, 115, 135, 150, 177, and 185.

### Strobe

The strobe shall be a System Sensor SpectrAlert Advance Model \_\_\_\_\_ listed to UL 1971 and shall be approved for fire protective service. The strobe shall be wired as a primary-signaling notification appliance and comply with the Americans with Disabilities Act requirements for visible signaling appliances, flashing at 1 Hz over the strobe's entire operating voltage range. The strobe light shall consist of a xenon flash tube and associated lens/reflector system. The strobe must be installed with its weatherproof back box in order to remain outdoor approved per UL. The strobe shall be suitable for use in wet environments.

### Horn Strobe Combination

The horn strobe shall be a System Sensor SpectrAlert Advance Model \_\_\_\_\_ listed to UL 1971 and UL 464 and shall be approved for fire protective service. The horn strobe shall be wired as a primary-signaling notification appliance and comply with the Americans with Disabilities Act requirements for visible signaling appliances, flashing at 1 Hz over the strobe's entire operating voltage range. The strobe light shall consist of a xenon flash tube and associated lens/reflector system. The horn shall have three audibility options and an option to switch between a temporal three pattern and a non-temporal (continuous) pattern. These options shall be set by a multiple position switch. On four-wire products, the strobe shall be powered independently of the sounder. The horn or horn strobe models shall operate on a coded or non-coded power supply. The horn strobe must be installed with its weatherproof back box in order to remain outdoor approved per UL. The horn strobe shall be suitable for use in wet environments.

## Physical/Electrical Specifications

<b>Operating Temperature</b>	–40°F to 151°F (–40°C to 66°C)
<b>Strobe Flash Rate</b>	1 flash per second
<b>Nominal Voltage</b>	Regulated 12 DC/FWR or regulated 24 DC/FWR <sup>1</sup>
<b>Operating Voltage Range<sup>2</sup></b>	8 to 17.5 V (12 V nominal) or 16 to 33 V (24 V nominal)
<b>Input Terminal Wire Gauge</b>	12 to 18 AWG
<b>Wall-Mount Dimensions (including lens)</b>	5.6" L × 4.7" W × 2.5" D (142 mm L × 119 mm W × 64 mm D)
<b>Horn Dimensions</b>	5.6" L × 4.7" W × 1.3" D (142 mm L × 119 mm W × 33 mm D)
<b>Wall-Mount Weatherproof Back Box Dimensions (SA-WBB)</b>	5.7" L × 5.1" W × 2.0" D (145 mm L × 130 mm W × 51 mm D)

### Notes:

1. Full Wave Rectified (FWR) voltage is a non-regulated, time-varying power source that is used on some power supply and panel outputs.
2. P, S, PC, and SC products will operate at 12 V nominal only for 15 and 15/75 cd.

## UL Current Draw Data

UL Max. Strobe Current Draw (mA RMS)						UL Max. Horn Current Draw (mA RMS)					
	Candela	8–17.5 Volts		16–33 Volts		Sound Pattern	dB	8–17.5 Volts		16–33 Volts	
		DC	FWR	DC	FWR			DC	FWR	DC	FWR
Standard Candela Range	15	123	128	66	71	Temporal	High	57	55	69	75
	15/75	142	148	77	81	Temporal	Medium	44	49	58	69
	30	NA	NA	94	96	Temporal	Low	38	44	44	48
	75	NA	NA	158	153	Non-Temporal	High	57	56	69	75
	95	NA	NA	181	176	Non-Temporal	Medium	42	50	60	69
	110	NA	NA	202	195	Non-Temporal	Low	41	44	50	50
	115	NA	NA	210	205	Coded	High	57	55	69	75
High Candela Range	135	NA	NA	228	207	Coded	Medium	44	51	56	69
	150	NA	NA	246	220	Coded	Low	40	46	52	50
	177	NA	NA	281	251						
	185	NA	NA	286	258						

UL Max. Current Draw (mA RMS), 2-Wire Horn Strobe, Standard Candela Range (15–115 cd)									
DC Input	8–17.5 Volts			16–33 Volts					
	15	15/75	15	15/75	30	75	95	110	115
Temporal High	137	147	79	90	107	176	194	212	218
Temporal Medium	132	144	69	80	97	157	182	201	210
Temporal Low	132	143	66	77	93	154	179	198	207
Non-Temporal High	141	152	91	100	116	176	201	221	229
Non-Temporal Medium	133	145	75	85	102	163	187	207	216
Non-Temporal Low	131	144	68	79	96	156	182	201	210
<b>FWR Input</b>									
Temporal High	136	155	88	97	112	168	190	210	218
Temporal Medium	129	152	78	88	103	160	184	202	206
Temporal Low	129	151	76	86	101	160	184	194	201
Non-Temporal High	142	161	103	112	126	181	203	221	229
Non-Temporal Medium	134	155	85	95	110	166	189	208	216
Non-Temporal Low	132	154	80	90	105	161	184	202	211

UL Max. Current Draw (mA RMS), 2-Wire Horn Strobe, High Candela Range (135–185 cd)									
DC Input	16–33 Volts				FWR Input	16–33 Volts			
	135	150	177	185		135	150	177	185
Temporal High	245	259	290	297	Temporal High	215	231	258	265
Temporal Medium	235	253	288	297	Temporal Medium	209	224	250	258
Temporal Low	232	251	282	292	Temporal Low	207	221	248	256
Non-Temporal High	255	270	303	309	Non-Temporal High	233	248	275	281
Non-Temporal Medium	242	259	293	299	Non-Temporal Medium	219	232	262	267
Non-Temporal Low	238	254	291	295	Non-Temporal Low	214	229	256	262

## Candela Derating

For K series products used at low temperatures, listed candela ratings must be reduced in accordance with this table.

Strobe Output (cd)	
Listed Candela	Candela rating at –40°F
15	Do not use below 32°F
15/75	
30	
75	
95	44
110	70
115	110
135	115
150	135
177	150
185	177

## Horn Tones and Sound Output Data

Horn and Horn Strobe Output (dBA)											
Switch Position	Sound Pattern	dB	8–17.5 Volts		16–33 Volts		24-Volt Nominal				
			DC	FWR	DC	FWR	Reverberant		Anechoic		
			DC	FWR	DC	FWR	DC	FWR	DC	FWR	
1	Temporal	High	78	78	84	84	88	88	99	98	
2	Temporal	Medium	74	74	80	80	86	86	96	96	
3	Temporal	Low	71	73	76	76	83	80	94	89	
4	Non-Temporal	High	82	82	88	88	93	92	100	100	
5	Non-Temporal	Medium	78	78	85	85	90	90	98	98	
6	Non-Temporal	Low	75	75	81	81	88	84	96	92	
7†	Coded	High	82	82	88	88	93	92	101	101	
8†	Coded	Medium	78	78	85	85	90	90	97	98	
9†	Coded	Low	75	75	81	81	88	85	96	92	

†Settings 7, 8, and 9 are not available on 2-wire horn strobe.

## SpectrAlert Advance Diagrams

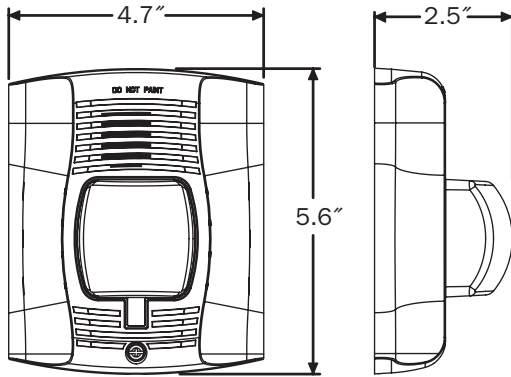

Wall-Mount Horn Strobes

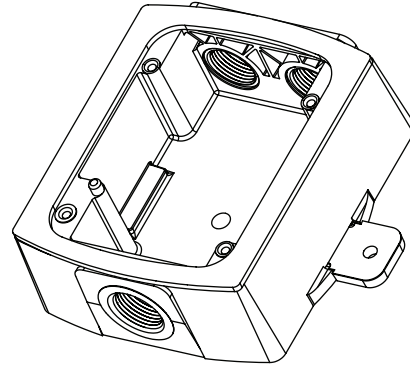

Wall Plastic Weatherproof Back Box

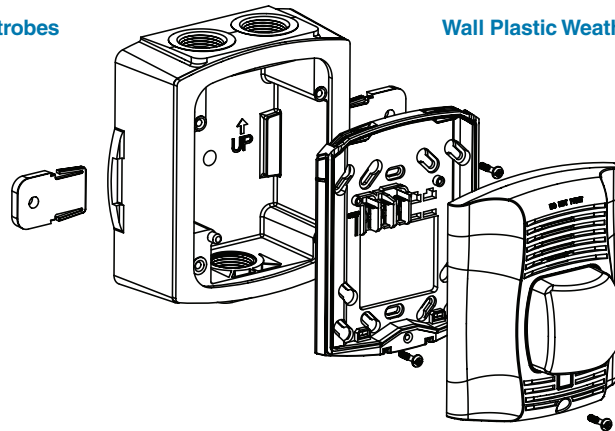

Wall-Mount Horn Strobe with Plastic Weatherproof Back Box

## SpectrAlert Advance Ordering Information

Model	Description
<b>Wall Horn Strobes</b>	
P2RK*†	2-Wire Horn Strobe, Standard cd, Red, Outdoor (includes plastic weatherproof back box)
P2RHK*†	2-Wire Horn Strobe, High cd, Red, Outdoor (includes plastic weatherproof back box)
P2WK*†	2-Wire Horn Strobe, Standard cd, White, Outdoor (includes plastic weatherproof back box)
P2WHK*†	2-Wire Horn Strobe, High cd, White, Outdoor (includes plastic weatherproof back box)
P4RK†	4-Wire Horn Strobe, Standard cd, Red, Outdoor (includes plastic weatherproof back box)
P4WK	4-Wire Horn Strobe, Standard cd, White, Outdoor (includes plastic weatherproof back box)
P2RHK-120	2-Wire Horn Strobe, High cd, Red, Outdoor, 120 V (includes plastic weatherproof back box)
<b>Wall Strobes</b>	
SRK*†	Strobe, Standard cd, Red, Outdoor (includes plastic weatherproof back box)
SRHK*†	Strobe, High cd, Red, Outdoor (includes plastic weatherproof back box)
SWK*†	Strobe, Standard cd, White, Outdoor (includes plastic weatherproof back box)
SWHK*†	Strobe, High cd, White, Outdoor (includes plastic weatherproof back box)
<b>Horns</b>	
HRK†	Horn, Red, Outdoor (includes plastic weatherproof back box)
<b>Accessories</b>	
SA-WBB	Red, Metal Weatherproof Back Box
SA-WBBW	White, Metal Weatherproof Back Box

### Notes:

\* Add "-P" to model number for plain housing (no "FIRE" marking on cover), e.g., P2RK-P.

† Add "-R" to model number for weatherproof replacement device (no back box included), only for use with weatherproof outdoor flush mounting plate, WTP and WTPW. "Standard cd" refers to strobes that include 15, 15/75, 30, 75, 95, 110, and 115 candela settings. "High cd" refers to strobes that include 135, 150, 177, and 185 candela settings. **When replacing standard outdoor units both the device and back box must be replaced.**



3825 Ohio Avenue • St. Charles, IL 60174  
Phone: 800-SENSOR2 • Fax: 630-377-6495

©2012 System Sensor.  
Product specifications subject to change without notice. Visit [systemsensor.com](http://systemsensor.com)  
for current product information, including the latest version of this data sheet.  
AVDS01201 • 3/12





## FEATURES

- 18 gauge cold rolled steel construction with red powder coat and white lettering
- Dimensions are 12" wide x 13" tall and 2 1/4" deep
- Stainless steel piano hinge
- Two key ring hooks to hold system keys
- Business card holder for key contacts
- Slide tab allows user to select USB-C or Micro USB connector to download from 8GB digital flash memory



## FAD

### Fire Alarm Documents

Store important system documents in a secure location with a cabinet built specifically to meet the requirements of NFPA 72 7.7.2.4.

The number one goal at Space Age is to manufacture code compliant solutions, and the FAD is just that. NFPA 72 7.7.2.1 states, "With every new system, a documentation cabinet shall be installed at the system control unit or other approved location at the protected premises."

The FAD includes our innovative 8GB flash drive slide tab that allows the user to select a USB-C or Micro USB connector to access records electronically (See NFPA 72 7.5.6.7).

## SPECIFICATIONS

The FAD Fire Alarm Documents Box shall be UL Listed, constructed of 18 gauge cold rolled steel. It shall have a powder coat finish. The cover shall be permanently screed with lettering "FIRE ALARM DOCUMENTS" with white indelible ink. The access door shall be locked with a 3/4" barrel lock and there will be a 12" stainless steel piano hinge. The FAD will have a minimum of 8 gigabyte digital flash memory drive with a slide tab that allows user to select USB-C or Micro USB connector for uploading and downloading information. The enclosure will supply 4 mounting holes. Inside will accommodate standard 8 1/2" x 11" manuals and document records. A legend sheet will be attached to the door for system required documentation, key contacts and system information. The enclosure shall also provide 2 key ring holders with a location to mount standard business cards for key contact personnel.

## CUSTOM COLORS AND BRANDING AVAILABLE



## DIMENSIONS

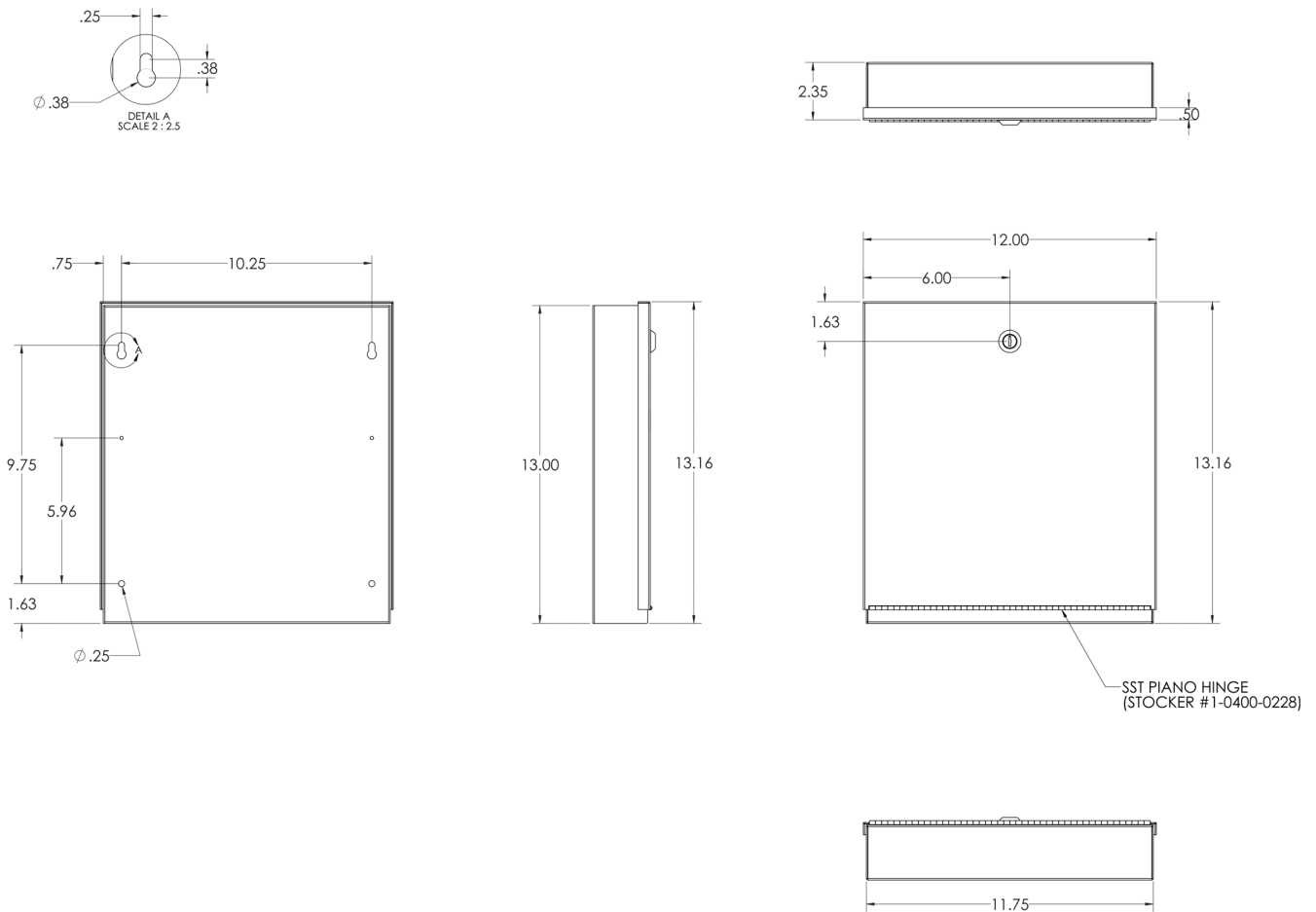

## ORDERING INFORMATION

**P/N# SSU00685**

Fire Alarm Documents Cabinet - Red

**P/N# SSU00686**

Fire Alarm Documents Cabinet - Red with your custom screened logo