

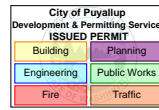

RED HAWK FIRE PROTECTION



Date: 9/13/2024

Job #: _____

System Type: FAS

Customer: _____

BURKE ELECTRIC
12605 44TH PL S
TUKWILA, WA 98178

Project: _____

CENTERIS DATA CENTER
1023 39TH AVENUE SOUTH EAST
PUYALLUP, WA 98374

Material List of Data Sheets

Item	Manufacture	Model	Description
1	Notifier	FDM-1	Addressable Monitor Module
2	System Sensor	P2WL	Wall Horn w/ Strobe, Multi-cd (15, 30, 75, 95, 110, 135 or 185cd)

This page intentionally left blank

Monitor Modules

NMM-100(A), NMM-100P(A), NZM-100(A), and NDM-100(A) for FireWarden Series



Intelligent Addressable Devices

General

Four different monitor modules are available for Notifier's FireWarden Series intelligent control panels for a variety of applications. Monitor modules supervise a circuit of dry-contact input devices, such as conventional heat detectors and pull stations, or monitor and power a circuit of two-wire smoke detectors (NZM-100(A)).

NMM-100(A) is a standard-sized module (typically mounts to a 4" [10.16 cm] square box) that supervises either a Style D (Class A) or Style B (Class B) circuit of dry-contact input devices.

NMM-100P(A) is a miniature monitor module a mere 1.3" (3.302 cm) H x 2.75" (6.985 cm) W x 0.65" (1.651 cm) D that supervises a Style B (Class B) circuit of dry-contact input devices. Its compact design allows the NMM-100P(A) to be mounted in a single-gang box behind the device it monitors.

NZM-100(A) is a standard-sized module that monitors and supervises compatible two-wire, 24 volt, smoke detectors on a Style D (Class A) or Style B (Class B) circuit.

NDM-100(A) is a standard-sized dual monitor module that monitors and supervises two independent two-wire Style B (Class B) dry-contact initiating device circuits (IDCs) at two separate, consecutive addresses in intelligent, two-wire systems.

LiteSpeed™ is a communication protocol that greatly increases the speed of communication between analog intelligent devices. Intelligent devices communicate in a grouped fashion. If one of the devices within the group has new information, the panel CPU stops the group poll and concentrates on single points. The net effect is response speed greater than five times that of other communication protocols.

NMM-100(A) Monitor Module

- Built-in type identification automatically identifies this device as a monitor module to the control panel.
- Powered directly by two-wire SLC loop. No additional power required.
- High noise (EMF/RFI) immunity.
- SEMS screws with clamping plates for ease of wiring.
- Direct-dial entry of address: 01 – 99 on FireWarden-100-2, 01 – 50 on FireWarden-50.
- LED flashes during normal operation and latches on steady to indicate alarm.

The NMM-100(A) Monitor Module is intended for use in intelligent, two-wire systems, where the individual address of each module is selected using the built-in rotary switches. It provides either a two-wire or four-wire fault-tolerant Initiating Device Circuit (IDC) for normally-open-contact fire alarm and supervisory devices. The module has a panel-controlled LED indicator.

NMM-100(A) APPLICATIONS

Use to monitor a zone of four-wire smoke detectors, manual fire alarm pull stations, waterflow devices, or other normally-open dry-contact alarm activation devices. May also be used



NMM-100(A) (Type H)

to monitor normally-open supervisory devices with special supervisory indication at the control panel. Monitored circuit may be wired as an NFPA Style B (Class B) or Style D (Class A) Initiating Device Circuit. A 47K Ohm End-of-Line Resistor (provided) terminates the Style B circuit. No resistor is required for supervision of the Style D circuit.

NMM-100(A) OPERATION

Each NMM-100(A) uses one of the available module addresses on an SLC loop. It responds to regular polls from the control panel and reports its type and the status (open/normal/short) of its Initiating Device Circuit (IDC). A flashing LED indicates that the module is in communication with the control panel. The LED latches steady on alarm (subject to current limitations on the loop).

NMM-100(A) SPECIFICATIONS

Nominal operating voltage: 15 to 32 VDC.

Maximum current draw: 5.0 mA (LED on).

Average operating current: 375 μ A (LED flashing), 1 communication every 5 seconds, 47k EOL.

Maximum IDC wiring resistance: 1500 Ohms.

Maximum IDC Voltage: 11 Volts.

EOL resistance: 47K Ohms.

Temperature range: 32°F to 120°F (0°C to 49°C).

Humidity range: 10% to 93% noncondensing.

Dimensions: 4.5" (11.43 cm) high x 4" (10.16 cm) wide x 1.25" (3.175 cm) deep. Mounts to a 4" (10.16 cm) square x 2.125" (5.398 cm) deep box.

NMM-100P(A) Mini Monitor Module

- Built-in type identification automatically identifies this device as a monitor module to the panel.

- Powered directly by two-wire SLC loop. No additional power required.
- High noise (EMF/RFI) immunity.
- Tinned, stripped leads for ease of wiring.
- Direct-dial entry of address: 01 – 99 on FireWarden-100-2, 01 – 50 on FireWarden-50.

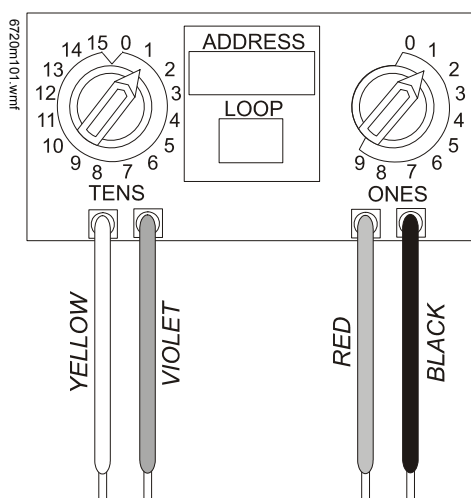

The NMM-100P(A) Mini Monitor Module can be installed in a single-gang junction directly behind the monitored unit. Its small size and light weight allow it to be installed without rigid mounting. The NMM-100P(A) is intended for use in intelligent, two-wire systems where the individual address of each module is selected using rotary switches. It provides a two-wire initiating device circuit for normally-open-contact fire alarm and security devices. NMM-100P(A)

NMM-100P(A) APPLICATIONS

Use to monitor a single device or a zone of four-wire smoke detectors, manual fire alarm pull stations, waterflow devices, or other normally-open dry-contact devices. May also be used to monitor normally-open supervisory devices with special supervisory indication at the control panel. Monitored circuit/device is wired as an NFPA Style B (Class B) Initiating Device Circuit. A 47K Ohm End-of-Line Resistor (provided) terminates the circuit.

NMM-100P(A) OPERATION

Each NMM-100P(A) uses one of the available module addresses on an SLC loop. It responds to regular polls from the control panel and reports its type and the status (open/normal/short) of its Initiating Device Circuit (IDC).

NMM-100P(A) SPECIFICATIONS

Nominal operating voltage: 15 to 32 VDC.

Average operating current: 350 μ A, 1 communication every 5 seconds, 47k EOL; 600 μ A Max. (Communicating, IDC Shorted).

Maximum IDC wiring resistance: 1500 Ohms.

Maximum IDC Voltage: 11 Volts.

Maximum IDC Current: 450 μ A.

EOL resistance: 47K Ohms.

Temperature range: 32°F to 120°F (0°C to 49°C).

Humidity range: 10% to 93% noncondensing.

Dimensions: 1.3" (3.302 cm) high x 2.75" (6.985 cm) wide x 0.65" (1.651 cm) deep.

Wire length: 6" (15.24 cm) minimum.

NZM-100(A) Interface Module

- Supports compatible two-wire smoke detectors.
- Supervises IDC wiring and connection of external power source.
- High noise (EMF/RFI) immunity.
- SEMS screws with clamping plates for ease of wiring.
- Direct-dial entry of address: 01 – 99 on FireWarden-100-2, 01 – 50 on FireWarden-50.
- LED flashes during normal operation.
- LED latches steady to indicate alarm on command from control panel.

The NZM-100(A) Interface Module is intended for use in intelligent, addressable systems, where the individual address of each module is selected using built-in rotary switches. This module allows intelligent panels to interface and monitor two-wire conventional smoke detectors. It transmits the status (normal, open, or alarm) of one full zone of conventional detectors back to the control panel. All two-wire detectors being monitored must be UL compatible with the module.

NZM-100(A) APPLICATIONS

Use the NZM-100(A) to monitor a zone of two-wire smoke detectors. The monitored circuit may be wired as an NFPA Style B (Class B) or Style D (Class A) Initiating Device Circuit. A 3.9 K Ohm End-of-Line Resistor (provided) terminates the end of the Style B or D (class B or A) circuit (maximum IDC loop resistance is 25 Ohms). Install ELR across terminals 8 and 9 for Style D application.

NZM-100(A) OPERATION

Each NZM-100(A) uses one of the available module addresses on an SLC loop. It responds to regular polls from the control panel and reports its type and the status (open/normal/short) of its Initiating Device Circuit (IDC). A flashing LED indicates that the module is in communication with the control panel. The LED latches steady on alarm (subject to current limitations on the loop).

NZM-100(A) SPECIFICATIONS

Nominal operating voltage: 15 to 32 VDC.

Maximum current draw: 5.1 mA (LED on).

Maximum IDC wiring resistance: 25 Ohms.

Average operating current: 270 μ A, 1 communication and 1 LED flash every 5 seconds, 3.9k eol.

EOL resistance: 3.9K Ohms.

External supply voltage (between Terminals T10 and T11):

- DC voltage: 24 volts power limited.
- Ripple voltage: 0.1 Vrms maximum.
- Current: 90 mA per module maximum.

Temperature range: 32°F to 120°F (0°C to 49°C).

Humidity range: 10% to 93% noncondensing.

Dimensions: 4.5" (11.43 cm) high x 4" (10.16 cm) wide x 1.25" (3.175 cm) deep. Mounts to a 4" (10.16 cm) square x 2.125" (5.398 cm) deep box.

NDM-100(A) Dual Monitor Module

The NDM-100(A) Dual Monitor Module is intended for use in intelligent, two-wire systems. It provides two independent two-wire initiating device circuits (IDCs) at two separate, consecutive addresses. It is capable of monitoring normally open contact fire alarm and supervisory devices. The module has a single panel-controlled LED.

NOTE: The NDM-100(A) provides two Style B (Class B) IDC circuits ONLY. Style D (Class A) IDC circuits are NOT supported in any application.

NDM-100(A) SPECIFICATIONS

Normal operating voltage range: 15 to 32 VDC.

Maximum current draw: 6.4 mA (LED on).

Average operating current: 750 μ A (LED flashing).

Maximum IDC wiring resistance: 1,500 Ohms.

Maximum IDC Voltage: 11 Volts.

Maximum IDC Current: 240 μ A

EOL resistance: 47K Ohms.

Temperature range: 32° to 120°F (0° to 49°C).

Humidity range: 10% to 93% (non-condensing).

Dimensions: 4.5" (11.43 cm) high x 4" (10.16 cm) wide x 1.25" (3.175 cm) deep. Mounts to a 4" (10.16 cm) square x 2.125" (5.398 cm) deep box.

NDM-100(A) AUTOMATIC ADDRESSING

The NDM-100(A) automatically assigns itself to two addressable points, starting with the original address. For example, if the NDM-100(A) is set to address "26", then it will automatically assign itself to addresses "26" and "27".

NOTE: "Ones" addresses on the NDM-100(A) are 0, 2, 4, 6, or 8 only. Terminals 6 and 7 use the first address, and terminals 8 and 9 use the second address.



CAUTION:

Avoid duplicating addresses on the system.

Installation

NMM-100(A), NZM-100(A), and NDM-100(A) modules mount directly to a standard 4" (10.16 cm) square, 2.125" (5.398 cm) deep, electrical box. They may also be mounted to the SMB500 surface-mount box. Mounting hardware and installation instructions are provided with each module. All wiring must conform to applicable local codes, ordinances, and regulations. These modules are intended for power-limited wiring only.

The NMM-100P(A) module is intended to be wired and mounted without rigid connections inside a standard electrical box. All wiring must conform to applicable local codes, ordinances, and regulations.

Agency Listings and Approvals

In some cases, certain modules may not be listed by certain approval agencies, or listing may be in process. Consult factory for latest listing status.

- **UL:** S635.
- **ULC:** S635.
- **FM Approved.**

- **CSFM:** 7300-0028:0230 (NMM-100, NMM-100P, NZM-100); 7300-0028:0237 (NDM-100).
- **MEA:** 72-01-E Vol. 2 (NMM-100, NMM-100P, NZM-100); 227-03-E Vol. 3 (NDM-100).

Product Line Information

NOTE: "A" suffix indicates ULC-listed model.

NMM-100(A): Monitor module.

NMM-100P(A): Monitor module, miniature.

NZM-100(A): Monitor module, two-wire detectors.

NDM-100(A): Monitor module, dual, two independent Class B circuits.

SMB500: Optional surface-mount backbox.

NOTE: See installation instructions and refer to the SLC Wiring Manual, PN 52304.

Notifier® and FireWarden® are registered trademarks and LiteSpeed™ and FireWatch™ are trademarks of Honeywell International Inc.
©2015 by Honeywell International Inc. All rights reserved. Unauthorized use of this document is strictly prohibited.



This document is not intended to be used for installation purposes.
We try to keep our product information up-to-date and accurate.
We cannot cover all specific applications or anticipate all requirements.
All specifications are subject to change without notice.

For more information, contact Notifier. Phone: (203) 484-7161, FAX: (203) 484-7118.
www.notifier.com

Indoor Selectable-Output Horns, Strobes, and Horn Strobes for Wall Applications



Audio/Visual Devices

General

The L-Series offers the most versatile and easy-to-use line of horns, strobes, and horn strobes in the industry with lower current draws and modern aesthetics. With white and red plastic housings, standard and small footprint devices, and plain, FIRE-printed devices, L-Series can meet virtually any application requirement.

The L-Series product line of wall-mount horns, strobes, and horn strobes include a variety of features that increase their application versatility while simplifying installation. All devices feature plug-in designs with minimal intrusion into the back box, making installations fast and foolproof while virtually eliminating costly and time-consuming ground faults.

To further simplify installation and protect devices from construction damage, L-Series utilizes a universal mounting plate for all standard and compact models with an onboard shorting spring, so installers can test wiring continuity before the device is installed.

Installers can also easily adapt devices to suit a wide range of application requirements using field-selectable candela settings, automatic selection of 12- or 24-volt operation, and a rotary switch for horn tones with two volume selections.

Features

- Updated modern aesthetics.
- Small profile devices for Horns and Horn Strobes.
- Plug-in design with minimal intrusion into the back box.
- Tamper-resistant construction.
- Automatic selection of 12- or 24-volt operation at 15 and 30 candela.
- Field-selectable candela settings on wall units: 15, 30, 75, 95, 110, 135, and 185.
- Horn rated at 88+ dBA at 16 volts.
- Rotary switch for horn tone and two volume selections.
- Universal mounting plate for all standard and all compact wall units.
- Mounting plate shorting spring checks wiring continuity before device installation.
- Electrically Compatible with legacy SpectrAlert® and SpectrAlert Advance devices.
- Compatible with MDL3 sync module.
- Listed for wall mounting only.

Architectural/Engineering Specifications

General: L-Series standard horns, strobes, and horn strobes shall mount to a standard 2" x 4" x 1⁷/₈" back box, 4" x 4" x 1¹/₂" back box, 4" octagon back box, or double-gang back box. L-Series compact products shall mount to a single-gang 2" x 4" x 1⁷/₈" back box. A universal mounting plate shall be used for mounting ceiling and wall products for all standard-size models and a separate universal mounting plate shall be used for mounting compact wall models. The notification appliance circuit wiring shall terminate at the universal mounting plate. Also, L-Series products, when used with the Sync•Circuit™ Module accessory, shall be powered from a non-coded notification appliance circuit output and shall operate on a nominal



P2RL



P2GWL



SGWL



HWL

12 or 24 volts. When used with the Sync•Circuit Module, 12-volt-rated notification appliance circuit outputs shall operate between 8.5 and 17.5 volts; 24-volt-rated c appliance circuit outputs shall operate between 16.5 and 33 volts. Indoor L-Series products shall operate between 32 and 120 degrees Fahrenheit from a regulated DC or full-wave rectified unaltered power supply. Strobes and horn strobes shall have field-selectable candela settings including 15, 30, 75, 95, 110, 135, and 185.

Strobe. The strobe shall be a L-Series Model listed to UL 1971 and shall be approved for fire protective service. The strobe shall be wired as a primary-signaling notification appliance and comply with the Americans with Disabilities Act requirements for visible signaling appliances, flashing at 1 Hz over the strobe's entire operating voltage range. The strobe light shall consist of a xenon flash tube and associated lens/reflector system.

Horn Strobe Combination. The horn strobe shall be a L-Series Model listed to UL 1971 and UL 464 and shall be approved for fire protective service. The horn strobe shall be wired as a primary-signaling notification appliance and comply with the Americans with Disabilities Act requirements for visible signaling appliances, flashing at 1 Hz over the strobe's entire operating voltage range. The strobe light shall consist of a xenon flash tube and associated lens/reflector system. The horn shall have two audibility options and an option to switch between a temporal three pattern and a non-temporal (continuous) pattern. These options are set by a multiple position switch. The horn on horn strobe models shall operate on a coded or non-coded power supply.

Synchronization Module. The module shall be a Sync•Circuit model MDL3 listed to UL 464 and shall be approved for fire protective service. The module shall synchronize SpectrAlert strobes at 1 Hz and horns at temporal three. Also, while operating the strobes, the module shall silence the horns on horn strobe models over a single pair of wires. The module shall mount to a 4^{11/16}" x 4^{11/16}" x 2^{1/8}" back box. The module shall also control two Style Y (class B) circuits or one Style Z (class A) circuit. The module shall synchronize multiple zones. Daisy chaining two or more synchronization modules together will synchronize all the zones they control. The module shall not operate on a coded power supply.

PHYSICAL/ELECTRICAL SPECIFICATIONS

- **Standard Operating Temperature:** 32°F to 120°F (0°C to 49°C).
- **Humidity Range:** 10 to 93% non-condensing.
- **Strobe Flash Rate:** 1 flash per second.
- **Nominal Voltage:** Regulated 12 DC or regulated 24 DC/ FWR¹ (full wave rectified).
- **Operating Voltage Range²:** 8 to 17.5 V (12 V nominal) or 16 to 33 V (24 V nominal).
- **Operating Voltage Range:** MDL3 Sync Module 8.5 to 17.5 V (12 V nominal) or 16.5 to 33 V (24 V nominal).
- **Input Terminal Wire Gauge:** 12 to 18 AWG.
- **Wall-Mount Dimensions (including lens):** 5.6" L x 4.7" W x 1.25" D (143 mm L x 119 mm W x 32 mm D).
- **Compact Wall-Mount Dimensions (including lens):** 5.26" L x 3.46" W x 1.93" D (133 mm L x 88 mm W x 49 mm D).
- **Horn Dimensions:** 5.6" L x 4.7" W x 1.25" D (143 mm L x 119 mm W x 32 mm D).
- **Compact Horn Dimensions:** 5.25" L x 3.45" W x 1.25" D (133mm L x 88mm W x 32mm D).

NOTE:

1. Full Wave Rectified (FWR) voltage is a non-regulated, time-varying power source that is used on some power supply and panel outputs.
2. P, S, PC, and SC products will operate at 12 V nominal only for 15 cd and 30 cd.

L-Series Drawings

Compact Horn

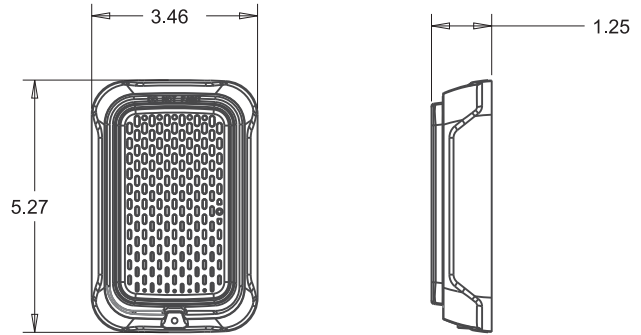

Compact Combo

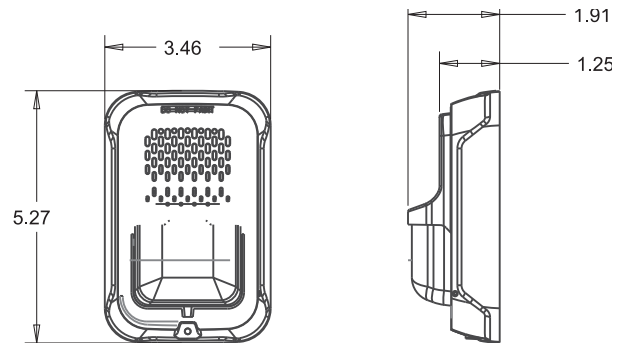

Horn

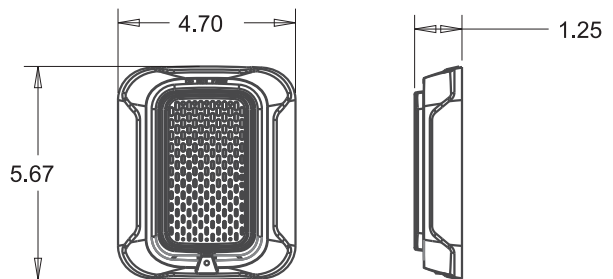

Combo

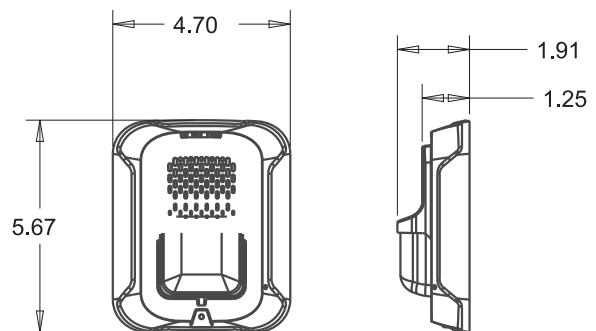

UL Current Draw Data

UL MAX. STROBE CURRENT DRAW (MA RMS)

Candela	8-17.5 Volts	16-33 Volts	
	DC	DC	FWR
15	88	43	60
30	143	63	83
75	N/A	107	136
95	N/A	121	155
110	N/A	148	179
135	N/A	172	209
185	N/A	222	257

UL MAX. HORN CURRENT DRAW (MA RMS)

The 3.1k is the sound of the mini-horns. The EM (which stands for Electro-mechanical) is the sound of the SpectrAlert Advance line which uses an algorithm that hops frequencies between 2Hz and 4Hz.

Sound Pattern	dB	8-17.5 Volts	16-33 Volts	
		DC	DC	FWR
Temporal	High	39	44	54
Temporal	Low	28	32	54
Non-Temporal	High	43	47	54
Non-Temporal	Low	29	32	54
3.1 KHz Temporal	High	39	41	54
3.1 KHz Temporal	Low	29	32	54
3.1 KHz Non-Temporal	High	42	43	54
3.1 KHz Non-Temporal	Low	28	29	54
Coded	High	43	47	54
3.1 KHz Coded	High	42	43	54

UL MAX. CURRENT DRAW (MA RMS), 2-WIRE HORN STROBE, CANDELA RANGE (15-115 CD)

The 3.1k is the sound of the mini-horns. The EM (which stands for Electro-mechanical) is the sound of the SpectrAlert Advance line which uses an algorithm that hops frequencies between 2Hz and 4Hz.

	DC Input: 8-17.5 Volts		DC Input: 16-33 Volts							FWR Input: 16 FWR						
	15 cd	30 cd	15 cd	30 cd	75 cd	95 cd	110 cd	135 cd	185 cd	15 cd	30 cd	75 cd	95 cd	110 cd	135 cd	185 cd
Temporal High	98	158	54	74	121	142	162	196	245	83	107	156	177	198	234	287
Temporal Low	93	154	44	65	111	133	157	184	235	68	91	145	165	185	223	271
Non-Temporal High	106	166	73	94	139	160	182	211	262	111	135	185	207	230	264	316
Non-Temporal Low	93	156	51	71	119	139	162	190	239	79	104	157	175	197	235	283
3.1K Temporal High	93	156	53	73	119	140	164	190	242	81	105	155	177	196	234	284
3.1K Temporal Low	91	154	45	66	112	133	160	185	235	68	90	145	166	186	222	276
3.1K Non-Temporal High	99	162	69	90	135	157	175	208	261	104	131	177	204	230	264	326
3.1K Non-Temporal Low	93	156	52	72	119	138	162	192	242	77	102	156	177	199	234	291

HORN TONES AND SOUND OUTPUT DATA: HORN AND HORN STROBE OUTPUT (DBA)

The 3.1k is the sound of the mini-horns. The EM (which stands for Electro-mechanical) is the sound of the SpectrAlert Advance line which uses an algorithm that hops frequencies between 2Hz and 4Hz.

In the coded positions, temporal coding must be provided by the NAC. If the NAC voltage is held constant, the horn output will remain constantly on.

Pos.	Sound Pattern	dB	8-17.5 Volts	16-33 Volts	
			DC	DC	FWR
1	Temporal	High	84	89	89
2	Temporal	Low	75	83	83
3	Non-Temporal	High	85	90	90
4	Non-Temporal	Low	76	84	84
5	3.1 KHz Temporal	High	83	88	88
6	3.1 KHz Temporal	Low	76	82	82
7	3.1 KHz Non-Temporal	High	84	89	89
8	3.1 KHz Non-Temporal	Low	77	83	83
9†	Coded	High	85	90	90
10†	3.1 KHz Coded	High	84	89	89

†Settings 9 and 10 are not available on the 2-wire horn strobes.

Agency Listings and Approvals

The listings and approvals below apply to L-series devices. In some cases, certain modules or applications may not be listed by certain approval agencies, or listing may be in process. Consult factory for latest listing status.

- **UL/ULC-Listed**
 - S4011 Wall Horn Strobes
 - S5512 Wall Strobes
 - S5512 Wall Horns
 - S5512 Strobe-only ALERT devices
- **FM Approved** (All except ALERT models)
- **CSFM Listed:** 7135-1653:0503 (Wall Horns and Wall Horn Strobes), 7125-1653:0504 (Wall Strobes)

Product Line Information

WALL HORN STROBES

P2WL(A)-(E)-(F), P2RL(A)-(E)-(F). 2-Wire, Horn Strobe (White, Red).

P2GWL(A)-(E)-(F), P2GRL(A)-(E)-(F). 2-Wire, Compact Horn Strobe (White, Red).

P2WL(A)-P, P2RL(A)-P. 2-Wire, Horn Strobe, Plain (White, Red).

P2WL-SP, P2RL-SP. 2-Wire, Horn Strobe, FUEGO (White, Red).

WALL STROBES

SWL(A)-(E)-(F), SRL(A)-(E)-(F). Strobe, Red (White, Red).

SGWL(A)-(E)-(F), SGRL(A)-(E)-(F). Compact Strobe (White, Red).

SWL(A)-P, SRL(A)-P. Strobe, Plain (White, Red).

SRL-SP. Strobe, FUEGO (Red).

SWL-CLR-ALERT. Strobe, ALERT (White).

SWL-ALERT. Strobe, Wall, Amber Lens, ALERT (White).

HORNS

HWL(A), HRL(A). Horn (White, Red).

HGWL(A), HGRL(A). Compact Horn (White, Red).

ACCESSORIES

TR-2W, TR-2. Universal Wall Trim Ring (White, Red).

SBBWL, SBBRL. Wall Surface Mount Back Box (White, Red).

SBBGWL, SBBGRL. Compact Wall Surface Mount Back Box (White, Red).

NOTE: "A" suffix indicates ULC-Listed model. ULC-listed devices include required French labeling. See Agency Listings for listing details.

NOTE: "A" suffix indicates ULC-listed models, ULC models have FIRE/FEU marking on cover.

NOTE: ULC-listed models add "-E" suffix for English only "FIRE" marking on cover.

NOTE: ULC-listed models add "-F" suffix for French only "FEU" marking on cover.

NOTIFIER® and SpectrAlert® are registered trademarks and SyncCircuit™ is a trademark of Honeywell International Inc. ©2017 by Honeywell International Inc. All rights reserved. Unauthorized use of this document is strictly prohibited.



This document is not intended to be used for installation purposes.
We try to keep our product information up-to-date and accurate.
We cannot cover all specific applications or anticipate all requirements.
All specifications are subject to change without notice.

For more information, contact Notifier. Phone: (203) 484-7161, FAX: (203) 484-7118.
www.notifier.com