



# STORM DRAINAGE REPORT

## Centeris Voltage Park

1023 39<sup>th</sup> Avenue SE  
Puyallup, Washington 98374

Prepared for:  
Benaroya Capital, LLC  
9675 SE 36<sup>th</sup> Avenue, Suite 115  
Mercer Island, WA 98040



7/3/24

Revised July 03, 2024  
Our Job No. 18111

Provide up-to-date wet season hydraulic conductivity testing and groundwater monitoring in accordance with City Standards and the criteria outlined in the previous DRT letters. (Wet season Small Scale PIT tests and wet season high groundwater elevation). Testing shall occur at the location and bottom elevation of the proposed infiltration facility. [Storm Report; Pg 1 of 239]

In an effort to keeping the civil application moving forward, and as a condition of final permit approval, the City is willing to use the Code mandated stormwater performance bond and tie the completion of the wet season testing to Final Approval of the Building Permit(s). The applicant shall either 1) acknowledge acceptance of this condition; or 2) provide the wet season testing prior to civil permit issuance. [Storm Report; Pg 1 of 239]

The applicant requests to provide a stormwater performance bond and will conduct the required wet season hydraulic conductivity testing and groundwater monitoring this coming wet season

## TABLE OF CONTENTS

1.	PROJECT OVERVIEW .....	1
2.	ANAYLSIS OF MINIMUM REQUIREMENTS.....	0
3.	EXISTING CONDITIONS SUMMARY .....	1
4.	PERMANENT STORMWATER CONTROL PLAN .....	2

*Appendix A*    **General Exhibits**

- Vicinity map
- Soils Map
- FEMA Map

*Appendix B*    **Facility Sizing**

- Basin Maps
- WWHM
- Conveyance Calculations

*Appendix C*    **Construction Stormwater**

- SWPPP

*Appendix D*    **Reports**

- Geotechnical Reports



## **1.0 PROJECT OVERVIEW**

## **1. PROJECT OVERVIEW**

The Centeris Voltage Park project is located on a 77-acre site. The site is located at 1023 39th Avenue SE within the City of Puyallup, Washington and encompasses three existing tax parcels (0419034036, 0419034037, and 0419034038). This redevelopment project will consist of developing new mechanical and electrical infrastructure to support new data center tenant loads. The project will include the addition of a new medium voltage feeder from the existing PSE sub-station in the southwest of the project site to the data center building along the northern edge of the project site and includes the addition of new cooling equipment and electrical equipment. More specifically, the project includes the addition of a switchgear building, underground electrical feeder conduits, and concrete pads to contain chillers, cooling towers, fluid coolers, generators and transformers. This storm drainage report accompanies the construction documents prepared for the project and provides site information and documentation in accordance with the 2019 Washington State Department of Ecology Stormwater Management Manual for Western Washington (SMMWW) and City of Puyallup standards.

## **2.0 ANALYSIS OF MINIMUM REQUIREMENTS**

## 2. ANALYSIS OF MINIMUM REQUIREMENTS

The following is a summary of the Minimum Requirements as described in Chapter 2 of Volume I of the 2019 SMMWW.

### Minimum Requirement #1: Preparation of a Stormwater Site Plan

The project creates more than 2,000 square feet of new and/or replaced impervious surfaces. A stormwater site plan has been prepared for the project.

### Minimum Requirement #2: Construction Stormwater Pollution Prevention (SWPP)

The project will consider all 13 elements of Construction Stormwater Pollution Prevention. The 13 elements are addressed in the SWPPP provided in Appendix C.

### Minimum Requirement #3: Source Control of Pollution

Permanent source control BMPs are already in place for the facility's daily operations.

### Minimum Requirement #4: Preservation of Natural Drainage System and Outfalls

The site will provide an infiltration facility which will drain flows into the surrounding native soils.

### Minimum Requirement #5: Onsite Stormwater Management

This project is not flow control exempt and triggers MRs #1 through #9, therefore, the project proposes the following BMPs:

#### Lawn and Landscape Areas:

Area of landscape will be disturbed with this site, therefore soils amendments under BMP T5.13 are applicable.

#### Roofs:

The switchgear building will disperse roof runoff from the new downspouts through BMPT5.10B splash blocks.

#### Other Hard Surfaces:

Based on site soils in the area of the new electrical and mechanical additions, we believe infiltration is feasible based on geotechnical investigation.

New gravel at the switchgear building will be fully dispersed to existing native vegetated areas.

### Minimum Requirement #6: Runoff Treatment

The redevelopment project does not create greater than 5,000 square feet of new pollution generating hard surfaces, therefore runoff treatment is not required.

### Minimum Requirement #7: Flow Control

The redevelopment project will apply flow control to the new hard surfaces by construction of an infiltration pond at the northern end of the site for stormwater disposal.

### Minimum Requirement #8: Wetlands Protection

This project does not propose any changes to the natural drainage system. The existing wetlands on and/or adjacent to the site will continue to function as in the existing condition.

### Minimum Requirement #9: Operation and Maintenance

A formal Operations and Maintenance Manual for stormwater facilities will be provided as needed.

See comment on Pg 1 of 239.  
[Storm Report; Pg 6 of 239]

The applicant requests to provide a stormwater performance bond and will conduct the required wet season hydraulic conductivity testing and groundwater monitoring this coming wet season

Does the Project result in 2,000 square feet, or more, of new plus replaced hard surface area?  
OR  
Does the land disturbing activity total 7,000 square feet or greater?

**Yes**

**No**

Minimum Requirements #1 through #5 apply to the new and replaced hard surfaces and the land disturbed.

**Minimum Requirement #2 applies.**

**Next Question**

Does the Project add 5,000 square feet or more of new hard surfaces?  
OR  
Convert  $\frac{3}{4}$  acres or more of vegetation to lawn or landscaped areas?  
OR  
Convert 2.5 acres or more of native vegetation to pasture?

**Yes**

**No**

**All Minimum Requirements apply to the new hard surfaces and the converted vegetation areas.**

**Next Question**

Is this a road related project?

**No**

**Yes**

Does the Project add 5,000 square feet or more of new hard surfaces?

**Yes**

**No**

Do the new hard surfaces add 50% or more to the existing hard surfaces within the Site?

**No**

**No additional requirements.**

**No**

Is the total of new plus replaced hard surfaces 5,000 square feet or more,  
AND  
does the value of the proposed improvements - including interior improvements - exceed 50% of the assessed value (or replacement value) of the:

- existing Project Site improvements (for commercial or industrial projects) OR
- existing Site improvements (for all other projects)

**Yes**

**All Minimum Requirements apply to the new and replaced hard surfaces and converted vegetation areas.**

**Yes**



DEPARTMENT OF  
**ECOLOGY**  
State of Washington

## Flow Chart for Determining Requirements for Redevelopment

Revised March 2019

Please see <http://www.ecy.wa.gov/copyright.html> for copyright notice including permissions, limitation of liability, and disclaimer.

## **3.0 EXISTING CONDITIONS SUMMARY**

### 3. EXISTING CONDITIONS SUMMARY

The overall facility encompasses approximately 77 acres. The existing site is irregular in shape and contains several buildings and existing data center facilities. The site was initially developed back in the 1980s. The majority of the subject property consists of impervious surfaces (buildings and asphalt pavement) surrounded by maintained lawn and ornamental, non-native landscaping. The undeveloped forested portions of the site contain fir and maple trees. The site is bound on the north and east by parcels owned by Pierce College and City of Puyallup Right-Of-Way, to the south by 39<sup>th</sup> Avenue SE and to the west by an existing senior living facility. Site soils in the area of redevelopment consist of primarily of Kapowsin gravelly ashy loam, Indianola loamy sands and Everett very gravelly sandy loams. Previous wetland investigations identified potential wetlands on the site, none of which are affected by the new mechanical or electrical infrastructure. The site is not located within any mapped floodplain. Please refer to the exhibits within Appendix A of this report.

The site is sloped to the northwest with elevations ranging from 545 along the eastern border to 450 at the northwest corner. A developed stormwater conveyance system exists consisting of ditches, catch basins, and stormwater pipes that collect and convey runoff from the parking areas and buildings. Stormwater flows to the northwest into a small onsite pond which infiltrates into surrounding soils. No drainage or erosion issues were reported or noted in our site reconnaissance.

There is no upstream basin contributing runoff to this project site as 39th Avenue S.E. forms the project site's southern boundary and has its own conveyance and collection system. To the east, the area drains primarily to the north around this property.

## **4.0 PERMANENT STORMWATER CONTROL PLAN**



## 4. PERMANENT STORMWATER CONTROL PLAN

### Existing Site Hydrology

The majority of the subject property consists of impervious surfaces (buildings and asphalt pavement) surrounded by maintained lawn and ornamental, non-native landscaping. The undeveloped forested portions of the site contain fir and maple trees. A developed stormwater conveyance system exists onsite consisting of ditches, catch basins, and stormwater pipe that collect and convey runoff from the parking and buildings.

### Developed Site Hydrology

Limits of site disturbance will include installation of sediment and erosion control Best Management Practices (BMPs), construction of new mechanical and electrical infrastructure, and stormwater facilities. The total disturbed area will cover approximately 1.21-acres.

Approximately 1.10-acres of new plus replaced hard surfaces are proposed with this redevelopment including 0.45-acres of new impervious and 0.65-acres of replaced impervious. Based on the flow chart for redevelopment, all minimum requirements are applicable to only the new hard surfaces. Please refer to the basin map within Appendix B

### Performance Standards and Goals

The Western Washington Hydrology Model (WWHM) methodology was used to meet the volume outflow design requirements for Standard Flow Control.

### Flow Control System

Flow control volumes for the new hard surfaces will be accommodated within an infiltration pond located at the northern end of the site. New target impervious surfaces total 0.45-acre. Due to the separation of improvements within the site, an equivalent (or greater) area of approximately 0.37-acre within the northern utility yard and 0.13-acre within the pond area will be collected and conveyed to the infiltration pond.

Approximately 2,450 cubic feet of storage is required, with 5,000 cubic yards being provided. The pond will infiltrate volumes into the surrounding native soils.

### Water Quality System

The redevelopment project does not create greater than 5,000 square feet of new pollution generating hard surfaces, therefore runoff treatment is not required.

### Conveyance System Analysis and Design

The new conveyance system will consist of overland sheet flow for the new building plus area drains, catch basins, and conveyance pipe for the new mechanical pad areas within the southern and northern utility yard areas.

Although this infiltration pond is relatively small, please address the concern/need for a pretreatment BMP to prevent clogging of the pond. Reference Ecology V-5.3 and III-1.2. [Storm Report; Pg 11 of 239]

Pretreatment was reviewed and a catch basin with a downturned elbow is being proposed since the runoff contributing to the pond is primarily from non-pollution generating impervious (rooftop and utility yard areas)

# **APPENDIX A**

## **VICINITY MAP**



REFERENCE: Rand McNally (2015)

Scale:

Horizontal: N.T.S.

Vertical: N/A

For:

Centeris Voltage Park  
Puyallup, Washington

Job Number

18111

Title:

VICINITY MAP

DATE: 2/1/24



18215 72ND AVENUE SOUTH  
KENT, WA 98032  
(425) 251-6222  
(425) 251-8782

CIVIL ENGINEERING, LAND PLANNING,  
SURVEYING, ENVIRONMENTAL SERVICES

# **SOILS MAP**





REFERENCE: USDA, Natural Resources Conservation Service

13B	Everett very gravelly sandy loam, 0 to 8 percent slopes
18C	Indianola loamy sand, 5 to 15 percent slopes
19B	Kapowsin gravelly ashy loam, 0 to 6 percent slopes
19C	Kapowsin gravelly ashy loam, 6 to 15 percent slopes
19E	Kapowsin gravelly ashy loam, 30 to 65 percent slopes
24D	Neilton gravelly loamy sand, 8 to 25 percent slopes

Scale:

Horizontal: N.T.S.

Vertical: N/A



18215 72ND AVENUE SOUTH  
KENT, WA 98032  
(425) 251-6222  
(425) 251-8782

CIVIL ENGINEERING, LAND PLANNING,  
SURVEYING, ENVIRONMENTAL SERVICES

For:

Centeris Voltage Park  
Puyallup, Washington

Title:

SOIL SURVEY MAP

Job Number

18111

DATE: 2/1/24

# FEMA MAP

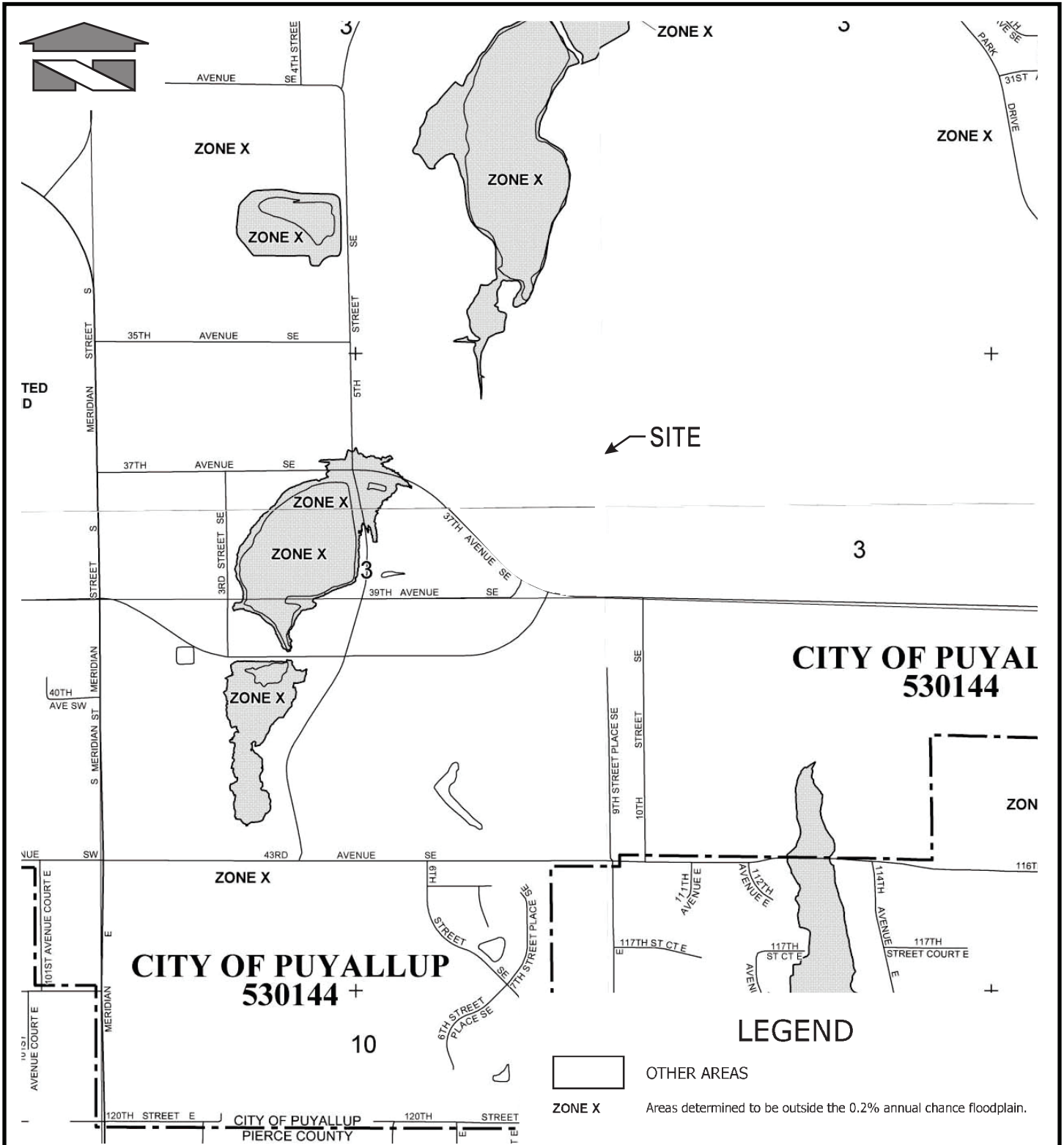

REFERENCE: Federal Emergency Management Agency (Portion of Maps 53053C0341E & 53053C0343E, Mar. 2017)

<p>Scale: Horizontal: N.T.S.      Vertical: N/A</p>	<p>For: <b>Centeris Voltage Park</b> <b>Puyallup, Washington</b></p>	<p>Job Number <b>18111</b></p>
 <p>18215 72ND AVENUE SOUTH KENT, WA 98032 (425) 251-6222 (425) 251-8782</p> <p>CIVIL ENGINEERING, LAND PLANNING, SURVEYING, ENVIRONMENTAL SERVICES</p>	<p>Title: <b>FEMA MAP</b></p>	<p>DATE:</p>



## **APPENDIX B**

# **BASIN MAPS**

**EXISTING SITE MAP  
FOR  
CENTERIS VOLTAGE PARK**

A PORTION OF THE NE 1/4, SE 1/4, NW 1/4, OF THE SE 1/4 OF SEC. 3, TWN. 19 N, RGE. 4 E, W.M. CITY OF PUYALLUP, PIERCE COUNTY, WASHINGTON

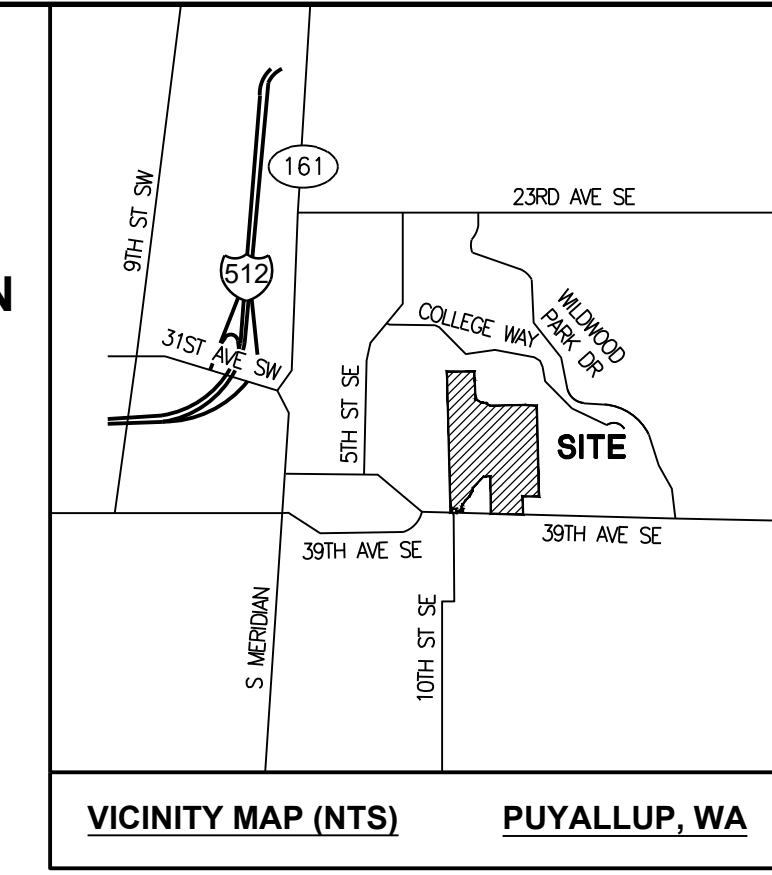
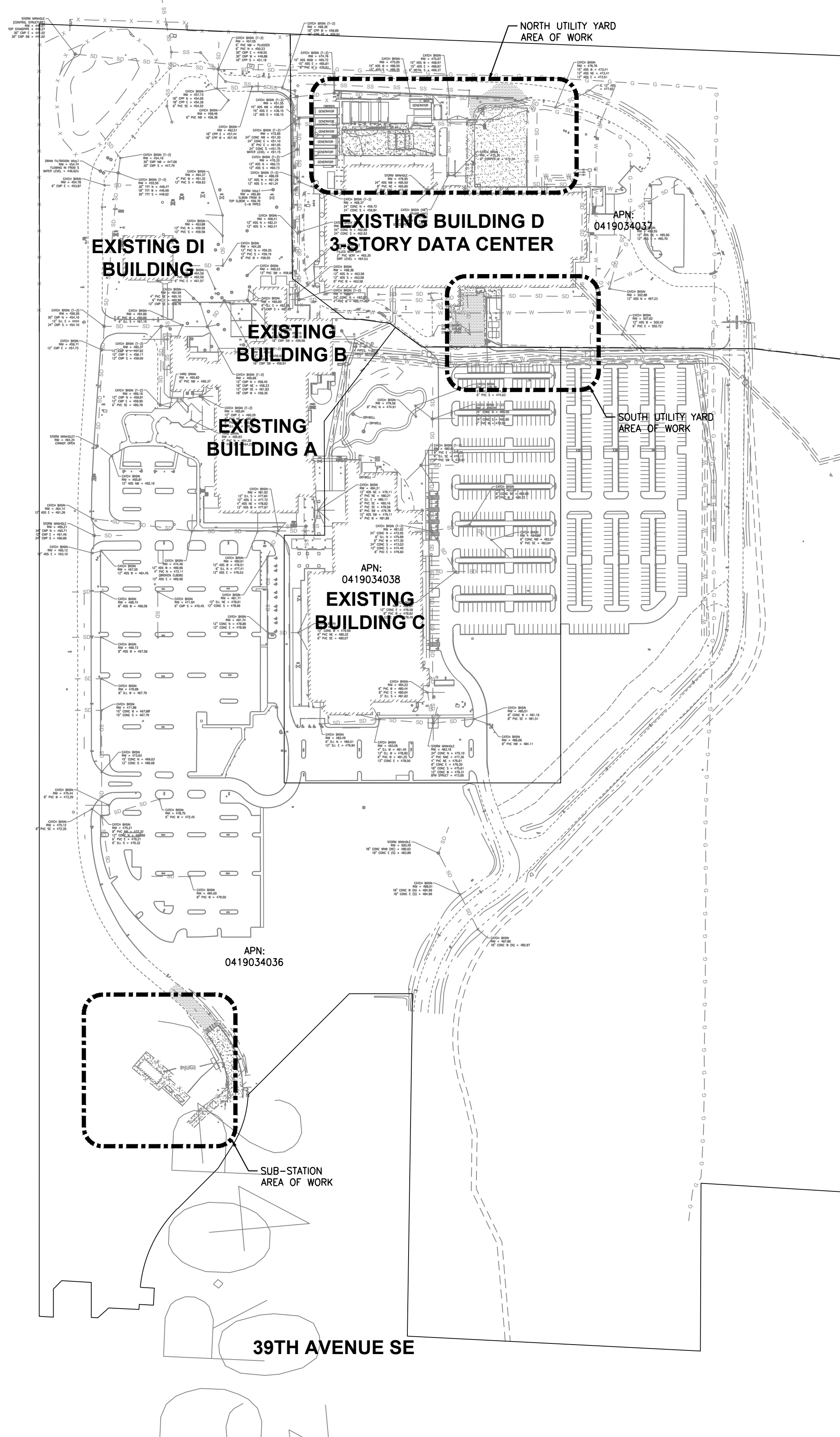

0 1/2" 1" 2"  
SCALE 1"= 150'

No.	Date	By	Ckd.	Appr.	Revision

**Title:**  
DEVELOPED SITE MAP  
**CENTERIS  
VOLTAGE PARK**

**For:**  
BENAROYA CAPITAL, LLC  
CENTERIS DATA CENTERS  
9675 SE 36TH ST, SUITE 115  
MERCER ISLAND, WA 98040

Scale:  
Horizontal  
1" = 150'  
Vertical  
N/A

Designed KDM  
Drawn KDM  
Checked CMV  
Approved DKB  
Date 2/2/24

**Barghausen  
Consulting Engineers, Inc.**  
18215 72nd Avenue South  
Kent, WA 98032  
425.251.6222 [barghausen.com](http://barghausen.com)

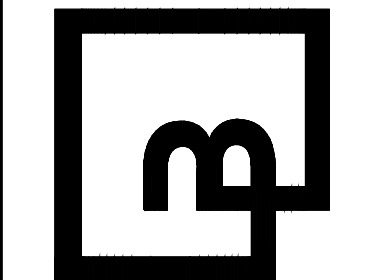

Job Number  
**18111**

Sheet  
**1** of **1**

**DEVELOPED SITE MAP  
FOR  
CENTERIS VOLTAGE PARK**

A PORTION OF THE NE 1/4, SE 1/4, NW 1/4, OF THE SE 1/4 OF SEC. 3, TWN. 19 N, RGE. 4 E, W.M. CITY OF PUYALLUP, PIERCE COUNTY, WASHINGTON

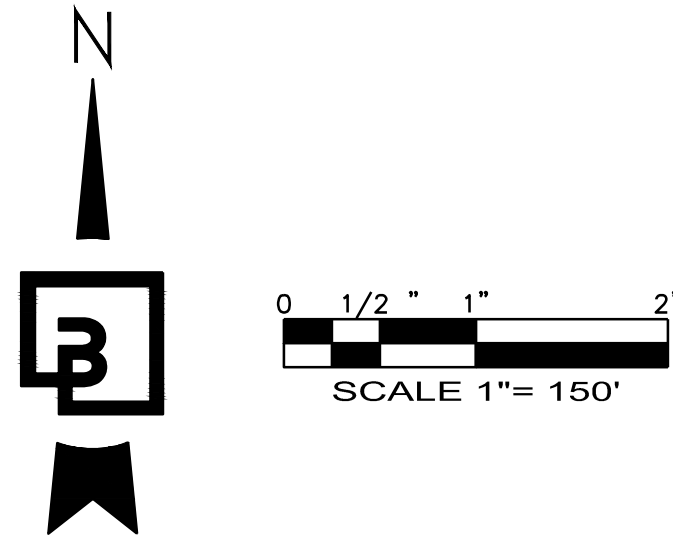
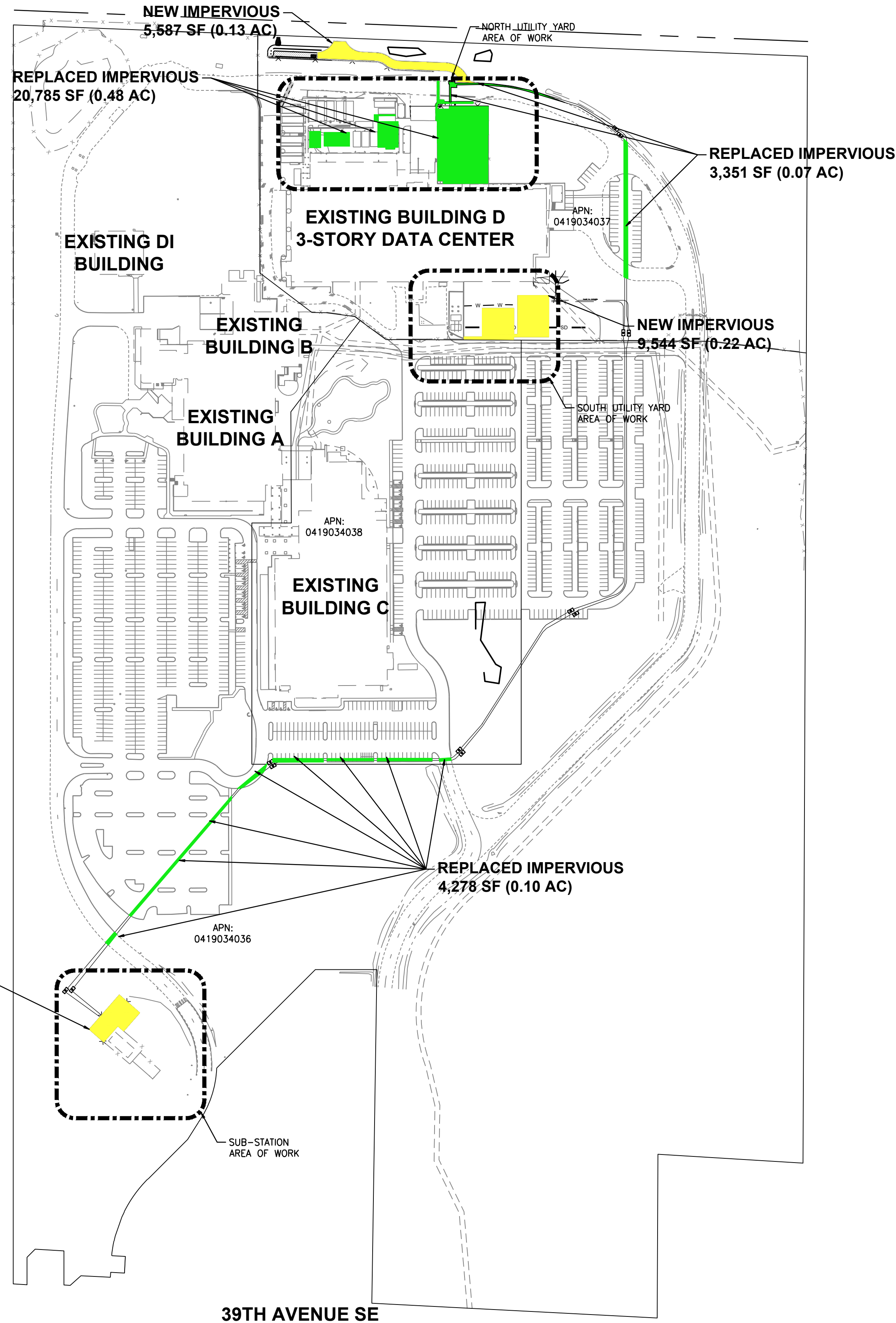
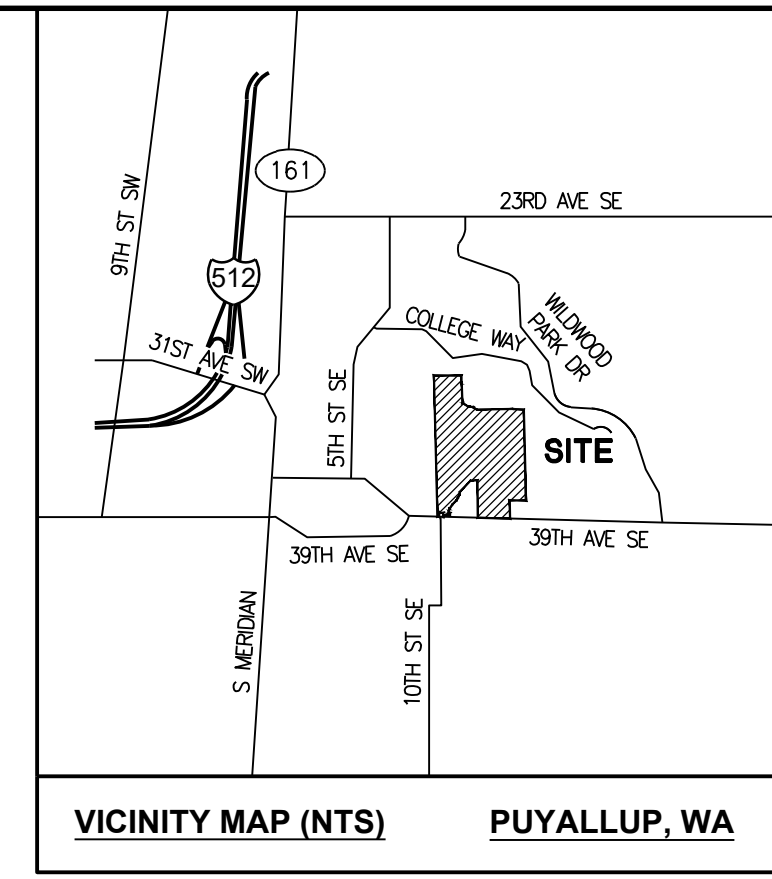

**IMPERVIOUS CALCULATIONS**

NEW IMPERVIOUS = 19,531 SF (0.45 AC)\*  
 REPLACED IMPERVIOUS = 28,414 SF (0.65 AC)  
 TOTAL NEW PLUS REPLACED = 47,945 SF (1.10 AC)  
 TOTAL DISTURBED PERVIOUS = 4,700 SF (0.11 AC)\*\*

\*4,400 SF (0.10 AC) OF NEW IMPERVIOUS LOCATED AT THE SUB-STATION WILL BE FULLY DISPERSED AND NOT INCLUDED IN THE MODEL. THIS AREA IS PRESUMED TO FULLY MEET FLOW CONTROL PER THE DOE MANUAL.

\*\* 4,700 SF (0.11 AC) OF DISTURBED PERVIOUS AREA WILL CONTAIN CONDUIT TRENCHING AND IS CONSIDERED FULLY DISPERSED INTO EXISTING NATIVE VEGETATION. THIS AREA IS PRESUMED TO FULLY MEET FLOW CONTROL PER THE DOE MANUAL.

Revision	
No.	Date
By	Ckd.
Appr.	

Title: DEVELOPED SITE MAP  
**CENTERIS VOLTAGE PARK**

For: **BENAROYA CAPITAL, LLC**  
**CENTERIS DATA CENTERS**  
 9675 SE 36TH ST, SUITE 115  
 MERCER ISLAND, WA 98040

Designed	KDM	Scale:
Drawn	KDM	Horizontal
Checked	CMV	1" = 150'
Approved	DKB	Vertical
Date	6/28/24	N/A

**Barghausen Consulting Engineers, Inc.**  
 18215 72nd Avenue South  
 Kent, WA 98032  
 425.251.6222 [barghausen.com](http://barghausen.com)

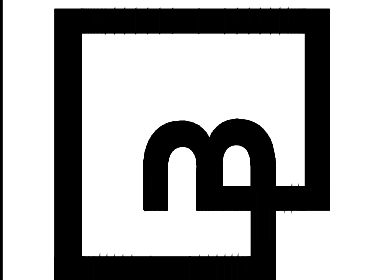

# **WWHM CALCULATIONS**

# WWHM2012

## PROJECT REPORT

See comment on Pg 1 of 239.  
[Storm Report; Pg 24 of 239]

The applicant requests to provide a stormwater performance bond and will conduct the required wet season hydraulic conductivity testing and groundwater monitoring this coming wet season

# General Model Information

Project Name: 18111-INF Final  
Site Name:  
Site Address:  
City:  
Report Date: 7/3/2024  
Gage: 40 IN EAST  
Data Start: 10/01/1901  
Data End: 09/30/2059  
Timestep: 15 Minute  
Precip Scale: 1.000  
Version Date: 2021/08/18  
Version: 4.2.18

## POC Thresholds

---

Low Flow Threshold for POC1:	50 Percent of the 2 Year
High Flow Threshold for POC1:	50 Year

---

*Landuse Basin Data*  
*Predeveloped Land Use*

**Basin 1**

Bypass: No

GroundWater: No

Pervious Land Use acre  
A B, Forest, Mod 0.6

Pervious Total 0.6

Impervious Land Use acre

Impervious Total 0

Basin Total 0.6

Element Flows To:  
Surface Interflow Groundwater



## Mitigated Land Use

### Basin 1

Bypass:	No
GroundWater:	No
Pervious Land Use	acre
Pervious Total	0
Impervious Land Use	acre
PARKING FLAT	0.6
Impervious Total	0.6
Basin Total	0.6

Element Flows To:  
Surface                      Interflow                      Groundwater  
Trapezoidal Pond 1    Trapezoidal Pond 1

*Routing Elements*  
*Predeveloped Routing*

## Mitigated Routing

### Trapezoidal Pond 1

Bottom Length:	86.00 ft.	
Bottom Width:	10.00 ft.	
Depth:	3 ft.	
Volume at riser head:	0.0568 acre-feet.	
Infiltration On		
Infiltration rate:	5.1	
Infiltration safety factor:	1	
Total Volume Infiltrated (ac-ft.):		256.299
Total Volume Through Riser (ac-ft.):		0
Total Volume Through Facility (ac-ft.):		256.299
Percent Infiltrated:		100
Total Precip Applied to Facility:		0
Total Evap From Facility:		0
Side slope 1:	2 To 1	
Side slope 2:	2 To 1	
Side slope 3:	2 To 1	
Side slope 4:	0.1 To 1	
Discharge Structure		
Riser Height:	2 ft.	
Riser Diameter:	18 in.	
Element Flows To:		
Outlet 1		Outlet 2

See comment Pg 1 of 239.  
[Storm Report; Pg 29 of 239]

The applicant requests to provide a stormwater performance bond and will conduct the required wet season hydraulic conductivity testing and groundwater monitoring this coming wet season

Pond Hydraulic Table

Stage(feet)	Area(ac.)	Volume(ac-ft.)	Discharge(cfs)	Infilt(cfs)
0.0000	0.019	0.000	0.000	0.000
0.0333	0.020	0.000	0.000	0.101
0.0667	0.020	0.001	0.000	0.101
0.1000	0.020	0.002	0.000	0.101
0.1333	0.020	0.002	0.000	0.101
0.1667	0.021	0.003	0.000	0.101
0.2000	0.021	0.004	0.000	0.101
0.2333	0.021	0.004	0.000	0.101
0.2667	0.022	0.005	0.000	0.101
0.3000	0.022	0.006	0.000	0.101
0.3333	0.022	0.007	0.000	0.101
0.3667	0.022	0.007	0.000	0.101
0.4000	0.023	0.008	0.000	0.101
0.4333	0.023	0.009	0.000	0.101
0.4667	0.023	0.010	0.000	0.101
0.5000	0.024	0.010	0.000	0.101
0.5333	0.024	0.011	0.000	0.101
0.5667	0.024	0.012	0.000	0.101
0.6000	0.024	0.013	0.000	0.101
0.6333	0.025	0.014	0.000	0.101
0.6667	0.025	0.015	0.000	0.101
0.7000	0.025	0.015	0.000	0.101
0.7333	0.026	0.016	0.000	0.101
0.7667	0.026	0.017	0.000	0.101
0.8000	0.026	0.018	0.000	0.101
0.8333	0.026	0.019	0.000	0.101
0.8667	0.027	0.020	0.000	0.101

0.9000	0.027	0.021	0.000	0.101
0.9333	0.027	0.022	0.000	0.101
0.9667	0.028	0.023	0.000	0.101
1.0000	0.028	0.024	0.000	0.101
1.0333	0.028	0.024	0.000	0.101
1.0667	0.028	0.025	0.000	0.101
1.1000	0.029	0.026	0.000	0.101
1.1333	0.029	0.027	0.000	0.101
1.1667	0.029	0.028	0.000	0.101
1.2000	0.030	0.029	0.000	0.101
1.2333	0.030	0.030	0.000	0.101
1.2667	0.030	0.031	0.000	0.101
1.3000	0.031	0.032	0.000	0.101
1.3333	0.031	0.033	0.000	0.101
1.3667	0.031	0.035	0.000	0.101
1.4000	0.031	0.036	0.000	0.101
1.4333	0.032	0.037	0.000	0.101
1.4667	0.032	0.038	0.000	0.101
1.5000	0.032	0.039	0.000	0.101
1.5333	0.033	0.040	0.000	0.101
1.5667	0.033	0.041	0.000	0.101
1.6000	0.033	0.042	0.000	0.101
1.6333	0.033	0.043	0.000	0.101
1.6667	0.034	0.044	0.000	0.101
1.7000	0.034	0.046	0.000	0.101
1.7333	0.034	0.047	0.000	0.101
1.7667	0.035	0.048	0.000	0.101
1.8000	0.035	0.049	0.000	0.101
1.8333	0.035	0.050	0.000	0.101
1.8667	0.036	0.051	0.000	0.101
1.9000	0.036	0.053	0.000	0.101
1.9333	0.036	0.054	0.000	0.101
1.9667	0.037	0.055	0.000	0.101
2.0000	0.037	0.056	0.000	0.101
2.0333	0.037	0.058	0.096	0.101
2.0667	0.037	0.059	0.273	0.101
2.1000	0.038	0.060	0.502	0.101
2.1333	0.038	0.061	0.771	0.101
2.1667	0.038	0.063	1.074	0.101
2.2000	0.039	0.064	1.404	0.101
2.2333	0.039	0.065	1.756	0.101
2.2667	0.039	0.067	2.123	0.101
2.3000	0.040	0.068	2.501	0.101
2.3333	0.040	0.069	2.882	0.101
2.3667	0.040	0.071	3.261	0.101
2.4000	0.041	0.072	3.632	0.101
2.4333	0.041	0.073	3.988	0.101
2.4667	0.041	0.075	4.326	0.101
2.5000	0.041	0.076	4.639	0.101
2.5333	0.042	0.077	4.924	0.101
2.5667	0.042	0.079	5.178	0.101
2.6000	0.042	0.080	5.401	0.101
2.6333	0.043	0.082	5.592	0.101
2.6667	0.043	0.083	5.754	0.101
2.7000	0.043	0.085	5.892	0.101
2.7333	0.044	0.086	6.014	0.101
2.7667	0.044	0.088	6.205	0.101
2.8000	0.044	0.089	6.338	0.101

2.8333	0.045	0.091	6.469	0.101
2.8667	0.045	0.092	6.597	0.101
2.9000	0.045	0.094	6.723	0.101
2.9333	0.046	0.095	6.846	0.101
2.9667	0.046	0.097	6.967	0.101
3.0000	0.046	0.098	7.086	0.101
3.0333	0.046	0.100	7.203	0.101

# Analysis Results

## POC 1

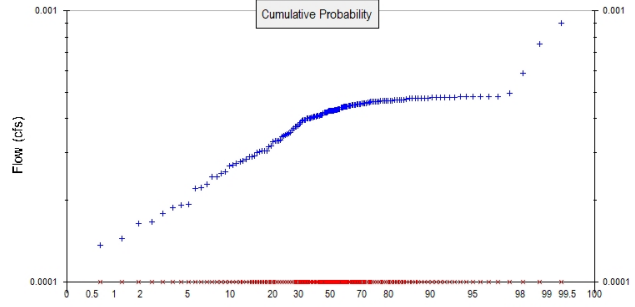
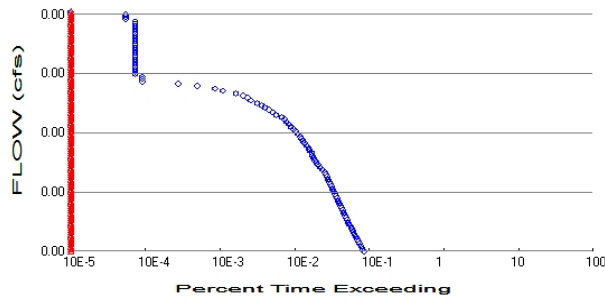

+ Predeveloped x Mitigated

### Predeveloped Landuse Totals for POC #1

Total Pervious Area: 0.6  
Total Impervious Area: 0

### Mitigated Landuse Totals for POC #1

Total Pervious Area: 0  
Total Impervious Area: 0.6

Flow Frequency Method: Log Pearson Type III 17B

### Flow Frequency Return Periods for Predeveloped. POC #1

Return Period	Flow(cfs)
2 year	0.000404
5 year	0.000495
10 year	0.000538
25 year	0.000577
50 year	0.000599
100 year	0.000616

### Flow Frequency Return Periods for Mitigated. POC #1

Return Period	Flow(cfs)
2 year	0
5 year	0
10 year	0
25 year	0
50 year	0
100 year	0

## Annual Peaks

### Annual Peaks for Predeveloped and Mitigated. POC #1

Year	Predeveloped	Mitigated
1902	0.000	0.000
1903	0.000	0.000
1904	0.000	0.000
1905	0.000	0.000
1906	0.000	0.000
1907	0.000	0.000
1908	0.000	0.000
1909	0.000	0.000
1910	0.000	0.000
1911	0.000	0.000

1912	0.001	0.000
1913	0.000	0.000
1914	0.000	0.000
1915	0.000	0.000
1916	0.000	0.000
1917	0.000	0.000
1918	0.000	0.000
1919	0.000	0.000
1920	0.000	0.000
1921	0.000	0.000
1922	0.000	0.000
1923	0.000	0.000
1924	0.000	0.000
1925	0.000	0.000
1926	0.000	0.000
1927	0.000	0.000
1928	0.000	0.000
1929	0.000	0.000
1930	0.000	0.000
1931	0.000	0.000
1932	0.000	0.000
1933	0.000	0.000
1934	0.000	0.000
1935	0.000	0.000
1936	0.000	0.000
1937	0.000	0.000
1938	0.000	0.000
1939	0.000	0.000
1940	0.000	0.000
1941	0.000	0.000
1942	0.000	0.000
1943	0.000	0.000
1944	0.000	0.000
1945	0.000	0.000
1946	0.000	0.000
1947	0.000	0.000
1948	0.000	0.000
1949	0.000	0.000
1950	0.000	0.000
1951	0.000	0.000
1952	0.000	0.000
1953	0.000	0.000
1954	0.000	0.000
1955	0.000	0.000
1956	0.000	0.000
1957	0.000	0.000
1958	0.000	0.000
1959	0.000	0.000
1960	0.000	0.000
1961	0.000	0.000
1962	0.000	0.000
1963	0.000	0.000
1964	0.000	0.000
1965	0.000	0.000
1966	0.000	0.000
1967	0.000	0.000
1968	0.000	0.000
1969	0.000	0.000

1970	0.000	0.000
1971	0.000	0.000
1972	0.000	0.000
1973	0.000	0.000
1974	0.000	0.000
1975	0.000	0.000
1976	0.000	0.000
1977	0.000	0.000
1978	0.000	0.000
1979	0.000	0.000
1980	0.000	0.000
1981	0.000	0.000
1982	0.000	0.000
1983	0.000	0.000
1984	0.000	0.000
1985	0.000	0.000
1986	0.000	0.000
1987	0.000	0.000
1988	0.000	0.000
1989	0.000	0.000
1990	0.000	0.000
1991	0.000	0.000
1992	0.000	0.000
1993	0.000	0.000
1994	0.000	0.000
1995	0.000	0.000
1996	0.000	0.000
1997	0.000	0.000
1998	0.000	0.000
1999	0.000	0.000
2000	0.000	0.000
2001	0.000	0.000
2002	0.000	0.000
2003	0.000	0.000
2004	0.000	0.000
2005	0.000	0.000
2006	0.000	0.000
2007	0.000	0.000
2008	0.000	0.000
2009	0.000	0.000
2010	0.000	0.000
2011	0.000	0.000
2012	0.000	0.000
2013	0.000	0.000
2014	0.000	0.000
2015	0.000	0.000
2016	0.000	0.000
2017	0.000	0.000
2018	0.001	0.000
2019	0.000	0.000
2020	0.000	0.000
2021	0.000	0.000
2022	0.000	0.000
2023	0.000	0.000
2024	0.000	0.000
2025	0.000	0.000
2026	0.000	0.000
2027	0.000	0.000



2028	0.000	0.000
2029	0.000	0.000
2030	0.000	0.000
2031	0.000	0.000
2032	0.000	0.000
2033	0.000	0.000
2034	0.000	0.000
2035	0.000	0.000
2036	0.000	0.000
2037	0.000	0.000
2038	0.000	0.000
2039	0.000	0.000
2040	0.000	0.000
2041	0.000	0.000
2042	0.000	0.000
2043	0.000	0.000
2044	0.000	0.000
2045	0.000	0.000
2046	0.000	0.000
2047	0.000	0.000
2048	0.000	0.000
2049	0.000	0.000
2050	0.000	0.000
2051	0.000	0.000
2052	0.000	0.000
2053	0.000	0.000
2054	0.000	0.000
2055	0.000	0.000
2056	0.000	0.000
2057	0.000	0.000
2058	0.000	0.000
2059	0.001	0.000

### Ranked Annual Peaks

Ranked Annual Peaks for Predeveloped and Mitigated. POC #1

Rank	Predeveloped	Mitigated
1	0.0009	0.0000
2	0.0008	0.0000
3	0.0006	0.0000
4	0.0005	0.0000
5	0.0005	0.0000
6	0.0005	0.0000
7	0.0005	0.0000
8	0.0005	0.0000
9	0.0005	0.0000
10	0.0005	0.0000
11	0.0005	0.0000
12	0.0005	0.0000
13	0.0005	0.0000
14	0.0005	0.0000
15	0.0005	0.0000
16	0.0005	0.0000
17	0.0005	0.0000
18	0.0005	0.0000
19	0.0005	0.0000
20	0.0005	0.0000
21	0.0005	0.0000
22	0.0005	0.0000

23	0.0005	0.0000
24	0.0005	0.0000
25	0.0005	0.0000
26	0.0005	0.0000
27	0.0005	0.0000
28	0.0005	0.0000
29	0.0005	0.0000
30	0.0005	0.0000
31	0.0005	0.0000
32	0.0005	0.0000
33	0.0005	0.0000
34	0.0005	0.0000
35	0.0005	0.0000
36	0.0005	0.0000
37	0.0005	0.0000
38	0.0005	0.0000
39	0.0005	0.0000
40	0.0005	0.0000
41	0.0005	0.0000
42	0.0005	0.0000
43	0.0005	0.0000
44	0.0005	0.0000
45	0.0005	0.0000
46	0.0005	0.0000
47	0.0005	0.0000
48	0.0005	0.0000
49	0.0005	0.0000
50	0.0005	0.0000
51	0.0005	0.0000
52	0.0005	0.0000
53	0.0005	0.0000
54	0.0004	0.0000
55	0.0004	0.0000
56	0.0004	0.0000
57	0.0004	0.0000
58	0.0004	0.0000
59	0.0004	0.0000
60	0.0004	0.0000
61	0.0004	0.0000
62	0.0004	0.0000
63	0.0004	0.0000
64	0.0004	0.0000
65	0.0004	0.0000
66	0.0004	0.0000
67	0.0004	0.0000
68	0.0004	0.0000
69	0.0004	0.0000
70	0.0004	0.0000
71	0.0004	0.0000
72	0.0004	0.0000
73	0.0004	0.0000
74	0.0004	0.0000
75	0.0004	0.0000
76	0.0004	0.0000
77	0.0004	0.0000
78	0.0004	0.0000
79	0.0004	0.0000
80	0.0004	0.0000

81	0.0004	0.0000
82	0.0004	0.0000
83	0.0004	0.0000
84	0.0004	0.0000
85	0.0004	0.0000
86	0.0004	0.0000
87	0.0004	0.0000
88	0.0004	0.0000
89	0.0004	0.0000
90	0.0004	0.0000
91	0.0004	0.0000
92	0.0004	0.0000
93	0.0004	0.0000
94	0.0004	0.0000
95	0.0004	0.0000
96	0.0004	0.0000
97	0.0004	0.0000
98	0.0004	0.0000
99	0.0004	0.0000
100	0.0004	0.0000
101	0.0004	0.0000
102	0.0004	0.0000
103	0.0004	0.0000
104	0.0004	0.0000
105	0.0004	0.0000
106	0.0004	0.0000
107	0.0004	0.0000
108	0.0004	0.0000
109	0.0004	0.0000
110	0.0004	0.0000
111	0.0004	0.0000
112	0.0004	0.0000
113	0.0004	0.0000
114	0.0004	0.0000
115	0.0004	0.0000
116	0.0004	0.0000
117	0.0004	0.0000
118	0.0004	0.0000
119	0.0003	0.0000
120	0.0003	0.0000
121	0.0003	0.0000
122	0.0003	0.0000
123	0.0003	0.0000
124	0.0003	0.0000
125	0.0003	0.0000
126	0.0003	0.0000
127	0.0003	0.0000
128	0.0003	0.0000
129	0.0003	0.0000
130	0.0003	0.0000
131	0.0003	0.0000
132	0.0003	0.0000
133	0.0003	0.0000
134	0.0003	0.0000
135	0.0003	0.0000
136	0.0003	0.0000
137	0.0003	0.0000
138	0.0003	0.0000

139	0.0003	0.0000
140	0.0003	0.0000
141	0.0003	0.0000
142	0.0003	0.0000
143	0.0003	0.0000
144	0.0003	0.0000
145	0.0002	0.0000
146	0.0002	0.0000
147	0.0002	0.0000
148	0.0002	0.0000
149	0.0002	0.0000
150	0.0002	0.0000
151	0.0002	0.0000
152	0.0002	0.0000
153	0.0002	0.0000
154	0.0002	0.0000
155	0.0002	0.0000
156	0.0001	0.0000
157	0.0001	0.0000
158	0.0001	0.0000

## Duration Flows

The Facility PASSED

Flow(cfs)	Predev	Mit	Percentage	Pass/Fail
0.0002	4638	0	0	Pass
0.0002	4457	0	0	Pass
0.0002	4280	0	0	Pass
0.0002	4101	0	0	Pass
0.0002	3969	0	0	Pass
0.0002	3797	0	0	Pass
0.0002	3642	0	0	Pass
0.0002	3498	0	0	Pass
0.0002	3389	0	0	Pass
0.0002	3281	0	0	Pass
0.0002	3135	0	0	Pass
0.0002	2971	0	0	Pass
0.0003	2882	0	0	Pass
0.0003	2791	0	0	Pass
0.0003	2682	0	0	Pass
0.0003	2602	0	0	Pass
0.0003	2490	0	0	Pass
0.0003	2406	0	0	Pass
0.0003	2348	0	0	Pass
0.0003	2269	0	0	Pass
0.0003	2202	0	0	Pass
0.0003	2136	0	0	Pass
0.0003	2053	0	0	Pass
0.0003	1972	0	0	Pass
0.0003	1900	0	0	Pass
0.0003	1838	0	0	Pass
0.0003	1786	0	0	Pass
0.0003	1727	0	0	Pass
0.0003	1676	0	0	Pass
0.0003	1597	0	0	Pass
0.0003	1544	0	0	Pass
0.0003	1497	0	0	Pass
0.0003	1443	0	0	Pass
0.0003	1384	0	0	Pass
0.0003	1297	0	0	Pass
0.0003	1215	0	0	Pass
0.0003	1136	0	0	Pass
0.0004	1085	0	0	Pass
0.0004	1027	0	0	Pass
0.0004	995	0	0	Pass
0.0004	967	0	0	Pass
0.0004	941	0	0	Pass
0.0004	877	0	0	Pass
0.0004	845	0	0	Pass
0.0004	806	0	0	Pass
0.0004	751	0	0	Pass
0.0004	713	0	0	Pass
0.0004	680	0	0	Pass
0.0004	648	0	0	Pass
0.0004	611	0	0	Pass
0.0004	571	0	0	Pass
0.0004	537	0	0	Pass
0.0004	490	0	0	Pass

0.0004	462	0	0	Pass
0.0004	433	0	0	Pass
0.0004	405	0	0	Pass
0.0004	369	0	0	Pass
0.0004	313	0	0	Pass
0.0004	282	0	0	Pass
0.0004	249	0	0	Pass
0.0004	221	0	0	Pass
0.0004	198	0	0	Pass
0.0005	174	0	0	Pass
0.0005	143	0	0	Pass
0.0005	129	0	0	Pass
0.0005	112	0	0	Pass
0.0005	90	0	0	Pass
0.0005	60	0	0	Pass
0.0005	47	0	0	Pass
0.0005	27	0	0	Pass
0.0005	15	0	0	Pass
0.0005	5	0	0	Pass
0.0005	5	0	0	Pass
0.0005	5	0	0	Pass
0.0005	4	0	0	Pass
0.0005	4	0	0	Pass
0.0005	4	0	0	Pass
0.0005	4	0	0	Pass
0.0005	4	0	0	Pass
0.0005	4	0	0	Pass
0.0005	4	0	0	Pass
0.0005	4	0	0	Pass
0.0005	4	0	0	Pass
0.0005	4	0	0	Pass
0.0005	4	0	0	Pass
0.0005	4	0	0	Pass
0.0005	4	0	0	Pass
0.0005	4	0	0	Pass
0.0005	4	0	0	Pass
0.0005	4	0	0	Pass
0.0005	4	0	0	Pass
0.0005	4	0	0	Pass
0.0005	4	0	0	Pass
0.0005	4	0	0	Pass
0.0005	4	0	0	Pass
0.0005	4	0	0	Pass
0.0005	4	0	0	Pass
0.0005	4	0	0	Pass
0.0005	4	0	0	Pass
0.0006	4	0	0	Pass
0.0006	4	0	0	Pass
0.0006	4	0	0	Pass
0.0006	4	0	0	Pass
0.0006	4	0	0	Pass
0.0006	4	0	0	Pass
0.0006	4	0	0	Pass
0.0006	4	0	0	Pass
0.0006	4	0	0	Pass
0.0006	4	0	0	Pass
0.0006	4	0	0	Pass
0.0006	4	0	0	Pass
0.0006	4	0	0	Pass
0.0006	4	0	0	Pass
0.0006	4	0	0	Pass
0.0006	3	0	0	Pass
0.0006	3	0	0	Pass
0.0006	3	0	0	Pass

## Water Quality

Water Quality BMP Flow and Volume for POC #1

On-line facility volume: 0 acre-feet

On-line facility target flow: 0 cfs.

Adjusted for 15 min: 0 cfs.

Off-line facility target flow: 0 cfs.

Adjusted for 15 min: 0 cfs.

# LID Report

LID Technique	Used for Treatment ?	Total Volume Needs Treatment (ac-ft)	Volume Through Facility (ac-ft)	Infiltration Volume (ac-ft)	Cumulative Volume Infiltration Credit	Percent Volume Infiltrated	Water Quality	Percent Water Quality Treated	Comment
Trapezoidal Pond 1 POC	<input type="checkbox"/>	233.23			<input type="checkbox"/>	100.00			
Total Volume Infiltrated		233.23	0.00	0.00		100.00	0.00	0%	No Treat. Credit
Compliance with LID Standard 8% of 2-yr to 50% of 2-yr									Duration Analysis Result = Passed



## *Model Default Modifications*

Total of 0 changes have been made.

### *PERLND Changes*

No PERLND changes have been made.

### *IMPLND Changes*

No IMPLND changes have been made.

*Appendix*  
*Predeveloped Schematic*

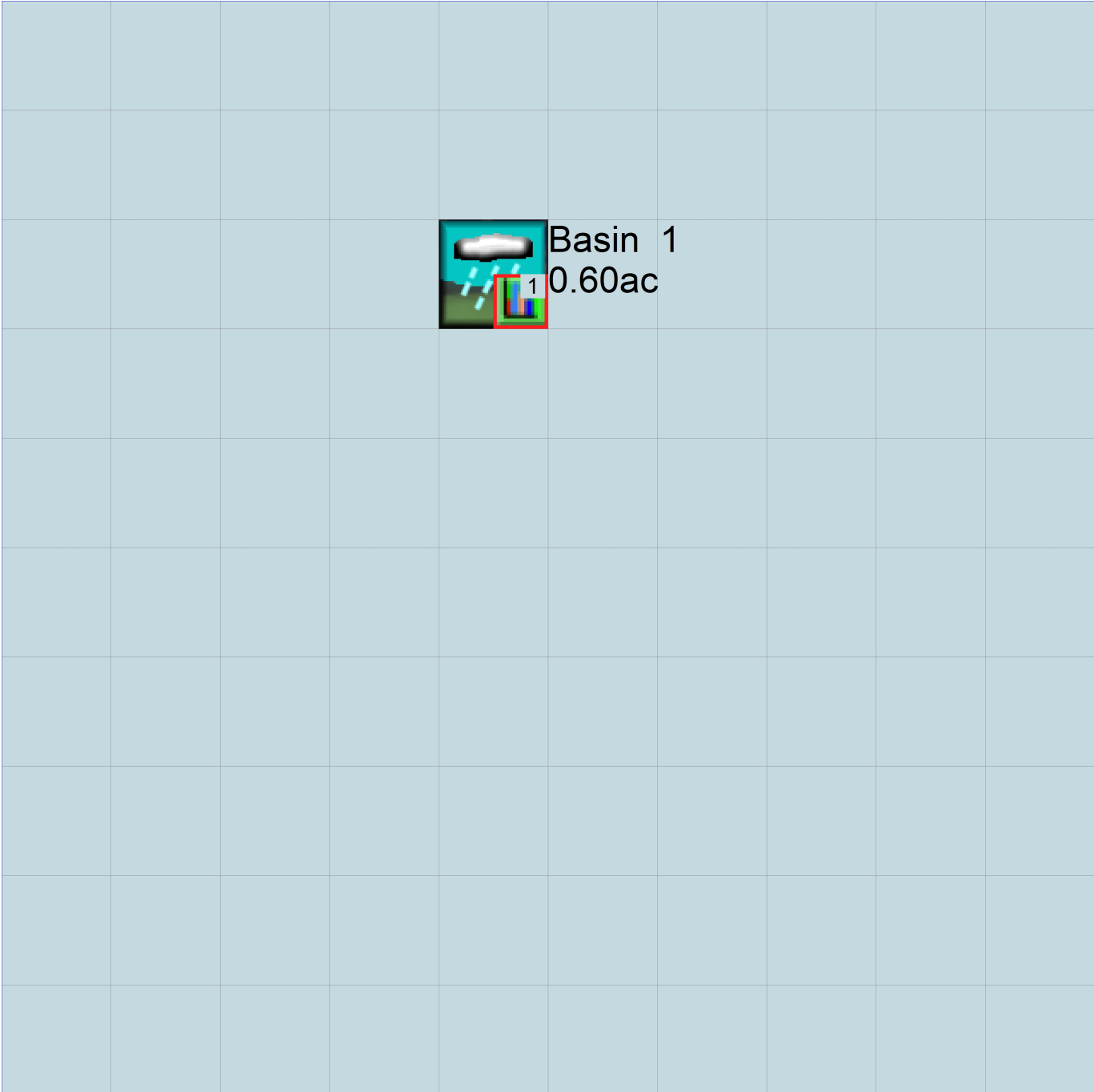

Mitigated Schematic



# Predeveloped UCI File

RUN

GLOBAL

```
WVHM4 model simulation
START      1901 10 01      END      2059 09 30
RUN INTERP OUTPUT LEVEL   3      0
RESUME     0 RUN          1
UNIT SYSTEM 1
```

END GLOBAL

FILES

```
<File> <Un#> <-----File Name----->***
<-ID->                                     ***
WDM      26      18111-INF Final.wdm
MESSU    25      Pre18111-INF Final.MES
          27      Pre18111-INF Final.L61
          28      Pre18111-INF Final.L62
          30      POC18111-INF Final1.dat
```

END FILES

OPN SEQUENCE

```
INGRP          INDELT 00:15
  PERLND        2
  COPY          501
  DISPLY        1
```

END INGRP

END OPN SEQUENCE

DISPLY

DISPLY-INFO1

```
# - #<-----Title----->***TRAN PIVL DIG1 FIL1  PYR DIG2 FIL2 YRND
1      Basin 1          MAX          1      2      30      9
```

END DISPLY-INFO1

END DISPLY

COPY

TIMESERIES

```
# - # NPT NMN ***
1      1      1
501    1      1
```

END TIMESERIES

END COPY

GENER

OPCODE

```
#      # OPCD ***
```

END OPCODE

PARAM

```
#      #          K ***
```

END PARAM

END GENER

PERLND

GEN-INFO

```
<PLS ><-----Name----->NBLKS  Unit-systems  Printer ***
# - #          User  t-series  Engl Metr ***
          in  out          ***
2      A/B, Forest, Mod  1      1      1      1      27      0
```

END GEN-INFO

\*\*\* Section PWATER\*\*\*

ACTIVITY

```
<PLS > ***** Active Sections *****
# - # ATMP SNOW PWAT  SED  PST  PWG  PQAL MSTL PEST NITR PHOS TRAC ***
2      0      0      1      0      0      0      0      0      0      0      0      0
```

END ACTIVITY

PRINT-INFO

```
<PLS > ***** Print-flags ***** PIVL  PYR
# - # ATMP SNOW PWAT  SED  PST  PWG  PQAL MSTL PEST NITR PHOS TRAC *****
2      0      0      4      0      0      0      0      0      0      0      0      0      1      9
```

END PRINT-INFO

```

PWAT-PARM1
<PLS > PWATER variable monthly parameter value flags ***
# - # CSNO RTOP UZFG VCS VUZ VNN VIFW VIRC VLE INFC HWT ***
2 0 0 0 0 0 0 0 0 0 0 0
END PWAT-PARM1

PWAT-PARM2
<PLS > PWATER input info: Part 2 ***
# - # ***FOREST LZSN INFILT LSUR SLSUR KVARY AGWRC
2 0 5 2 400 0.1 0.3 0.996
END PWAT-PARM2

PWAT-PARM3
<PLS > PWATER input info: Part 3 ***
# - # ***PETMAX PETMIN INFEXP INFILD DEEPFR BASETP AGWETP
2 0 0 2 2 0 0 0
END PWAT-PARM3

PWAT-PARM4
<PLS > PWATER input info: Part 4 ***
# - # CEPSC UZSN NSUR INTFW IRC LZETP ***
2 0.2 0.5 0.35 0 0.7 0.7
END PWAT-PARM4

PWAT-STATE1
<PLS > *** Initial conditions at start of simulation
ran from 1990 to end of 1992 (pat 1-11-95) RUN 21 ***
# - # *** CEPS SURS UZS IFWS LZS AGWS GWVS
2 0 0 0 0 3 1 0
END PWAT-STATE1

END PERLND

IMPLND
GEN-INFO
<PLS ><-----Name-----> Unit-systems Printer ***
# - # User t-series Engl Metr ***
in out ***
END GEN-INFO
*** Section IWATER***

ACTIVITY
<PLS > ***** Active Sections *****
# - # ATMP SNOW IWAT SLD IWG IQAL ***
END ACTIVITY

PRINT-INFO
<ILS > ***** Print-flags ***** PIVL PYR
# - # ATMP SNOW IWAT SLD IWG IQAL *****
END PRINT-INFO

IWAT-PARM1
<PLS > IWATER variable monthly parameter value flags ***
# - # CSNO RTOP VRS VNN RTLI ***
END IWAT-PARM1

IWAT-PARM2
<PLS > IWATER input info: Part 2 ***
# - # *** LSUR SLSUR NSUR RETSC
END IWAT-PARM2

IWAT-PARM3
<PLS > IWATER input info: Part 3 ***
# - # ***PETMAX PETMIN
END IWAT-PARM3

IWAT-STATE1
<PLS > *** Initial conditions at start of simulation
# - # *** RETS SURS
END IWAT-STATE1

```

END IMPLND

SCHEMATIC

<-Source->	<Name> #	<--Area-->	<-factor-->	<-Target->	<Name> #	MBLK	Tbl#	***
Basin	1***							
PERLND	2		0.6	COPY	501		12	
PERLND	2		0.6	COPY	501		13	

\*\*\*\*\*Routing\*\*\*\*\*  
END SCHEMATIC

NETWORK

<-Volume->	<-Grp>	<-Member->	<--Mult-->	Tran	<-Target vols>	<-Grp>	<-Member->	***	
<Name> #		<Name> #	#	<-factor-->strg	<Name> #	#	<Name> #	***	
COPY	501	OUTPUT	MEAN	1 1	48.4	DISPLY	1	INPUT	TIMSER 1

<-Volume->	<-Grp>	<-Member->	<--Mult-->	Tran	<-Target vols>	<-Grp>	<-Member->	***
<Name> #		<Name> #	#	<-factor-->strg	<Name> #	#	<Name> #	***

END NETWORK

RCHRES

GEN-INFO

RCHRES	Name	Nexits	Unit	Systems	Printer	***
# - #	<----->	<---->	User	T-series	Engl Metr	LKFG
			in	out		

END GEN-INFO  
\*\*\* Section RCHRES\*\*\*

ACTIVITY

<PLS > \*\*\*\*\* Active Sections \*\*\*\*\*

# - #	HYFG	ADFG	CNFG	HTFG	SDFG	GQFG	OXFG	NUFG	PKFG	PHFG	***

END ACTIVITY

PRINT-INFO

<PLS > \*\*\*\*\* Print-flags \*\*\*\*\* PIVL PYR

# - #	HYDR	ADCA	CONS	HEAT	SED	GQL	OXRX	NUTR	PLNK	PHCB	PIVL	PYR	*****

END PRINT-INFO

HYDR-PARM1

RCHRES	Flags for each HYDR Section	***	ODGTFG for each	FUNCT for each	***
# - #	VC A1 A2 A3	ODFVFG for each	***	possible exit	***
	FG FG FG FG	possible exit	***	possible exit	***
	* * * *	* * * * *		* * * *	

END HYDR-PARM1

HYDR-PARM2

# - #	FTABNO	LEN	DELTH	STCOR	KS	DB50	***
<----->	<----->	<----->	<----->	<----->	<----->	<----->	***

END HYDR-PARM2

HYDR-INIT

RCHRES	Initial conditions for each HYDR section	***
# - #	*** VOL	Initial value of COLIND
	*** ac-ft	for each possible exit
		Initial value of OUTDGT
		for each possible exit
	<----->	<----->
	<----->	<----->

END HYDR-INIT

END RCHRES

SPEC-ACTIONS

END SPEC-ACTIONS

FTABLES

END FTABLES

EXT SOURCES

<-Volume->	<Member>	SsysSgap	<--Mult-->	Tran	<-Target vols>	<-Grp>	<-Member->	***
<Name> #	<Name> #	tem	strg	<-factor-->strg	<Name> #	#	<Name> #	***
WDM	2	PREC	ENGL	1	PERLND	1 999	EXTNL	PREC
WDM	2	PREC	ENGL	1	IMPLND	1 999	EXTNL	PREC

WDM 1 EVAP ENGL 1 PERLND 1 999 EXTNL PETINP  
WDM 1 EVAP ENGL 1 IMPLND 1 999 EXTNL PETINP

END EXT SOURCES

EXT TARGETS

<-Volume-> <-Grp> <-Member-><--Mult-->Tran <-Volume-> <Member> Tsys Tgap Amd \*\*\*  
<Name> # <Name> # #<-factor->strg <Name> # <Name> tem strg strg\*\*\*  
COPY 501 OUTPUT MEAN 1 1 48.4 WDM 501 FLOW ENGL REPL  
END EXT TARGETS

MASS-LINK

<Volume> <-Grp> <-Member-><--Mult--> <Target> <-Grp> <-Member->\*\*\*  
<Name> <Name> # #<-factor-> <Name> <Name> # #\*\*\*  
MASS-LINK 12  
PERLND PWATER SURO 0.083333 COPY INPUT MEAN  
END MASS-LINK 12

MASS-LINK 13  
PERLND PWATER IFWO 0.083333 COPY INPUT MEAN  
END MASS-LINK 13

END MASS-LINK

END RUN

# Mitigated UCI File

RUN

GLOBAL

```
WVHM4 model simulation
START      1901 10 01      END      2059 09 30
RUN INTERP OUTPUT LEVEL   3      0
RESUME     0 RUN          1
UNIT SYSTEM 1
```

END GLOBAL

FILES

```
<File> <Un#> <-----File Name----->***
<-ID->                                     ***
WDM      26      18111-INF Final.wdm
MESSU    25      Mit18111-INF Final.MES
          27      Mit18111-INF Final.L61
          28      Mit18111-INF Final.L62
          30      POC18111-INF Final1.dat
```

END FILES

OPN SEQUENCE

```
INGRP          INDELT 00:15
  IMPLND        11
  RCHRES         1
  COPY          1
  COPY         501
  DISPLY        1
```

END INGRP

END OPN SEQUENCE

DISPLY

DISPLY-INFO1

```
# - #<-----Title----->***TRAN PIVL DIG1 FIL1  PYR DIG2 FIL2 YRND
1      Trapezoidal Pond 1      MAX      1      2      30      9
```

END DISPLY-INFO1

END DISPLY

COPY

TIMESERIES

```
# - # NPT NMN ***
1      1      1
501    1      1
```

END TIMESERIES

END COPY

GENER

OPCODE

```
#      # OPCD ***
```

END OPCODE

PARM

```
#      #      K ***
```

END PARM

END GENER

PERLND

GEN-INFO

```
<PLS ><-----Name----->NBLKS  Unit-systems  Printer ***
# - #      User  t-series  Engl Metr ***
                               in  out      ***
```

END GEN-INFO

\*\*\* Section PWATER\*\*\*

ACTIVITY

```
<PLS > ***** Active Sections *****
# - # ATMP SNOW PWAT  SED  PST  PWG PQAL MSTL PEST NITR PHOS TRAC ***
```

END ACTIVITY

PRINT-INFO

```
<PLS > ***** Print-flags ***** PIVL  PYR
# - # ATMP SNOW PWAT  SED  PST  PWG PQAL MSTL PEST NITR PHOS TRAC *****
```

END PRINT-INFO

PWAT-PARM1



```

<PLS > PWATER variable monthly parameter value flags ***
# - # CSNO RTOP UZFG VCS VUZ VNN VIFW VIRG VLE INFC HWT ***
END PWAT-PARM1

PWAT-PARM2
<PLS > PWATER input info: Part 2 ***
# - # ***FOREST LZSN INFILT LSUR SLSUR KVARY AGWRC
END PWAT-PARM2

PWAT-PARM3
<PLS > PWATER input info: Part 3 ***
# - # ***PETMAX PETMIN INFEXP INFILD DEEPFR BASETP AGWETP
END PWAT-PARM3
PWAT-PARM4
<PLS > PWATER input info: Part 4 ***
# - # CEPSC UZSN NSUR INTFW IRC LZETP ***
END PWAT-PARM4

PWAT-STATE1
<PLS > *** Initial conditions at start of simulation
ran from 1990 to end of 1992 (pat 1-11-95) RUN 21 ***
# - # *** CEPS SURS UZS IFWS LZS AGWS GWVS
END PWAT-STATE1

END PERLND

IMPLND
GEN-INFO
<PLS ><-----Name-----> Unit-systems Printer ***
# - # User t-series Engl Metr ***
in out ***
11 PARKING/FLAT 1 1 1 27 0
END GEN-INFO
*** Section IWATER***

ACTIVITY
<PLS > ***** Active Sections *****
# - # ATMP SNOW IWAT SLD IWG IQAL ***
11 0 0 1 0 0 0
END ACTIVITY

PRINT-INFO
<ILS > ***** Print-flags ***** PIVL PYR
# - # ATMP SNOW IWAT SLD IWG IQAL *****
11 0 0 4 0 0 0 1 9
END PRINT-INFO

IWAT-PARM1
<PLS > IWATER variable monthly parameter value flags ***
# - # CSNO RTOP VRS VNN RTLI ***
11 0 0 0 0 0
END IWAT-PARM1

IWAT-PARM2
<PLS > IWATER input info: Part 2 ***
# - # *** LSUR SLSUR NSUR RETSC
11 400 0.01 0.1 0.1
END IWAT-PARM2

IWAT-PARM3
<PLS > IWATER input info: Part 3 ***
# - # ***PETMAX PETMIN
11 0 0
END IWAT-PARM3

IWAT-STATE1
<PLS > *** Initial conditions at start of simulation
# - # *** RETS SURS
11 0 0
END IWAT-STATE1

```

END IMPLND

SCHEMATIC

<-Source->	<--Area-->	<-Target->	MBLK	***
<Name> #	<-factor->	<Name> #	Tbl#	***
Basin 1***				
IMPLND 11	0.6	RCHRES 1	5	

\*\*\*\*\*Routing\*\*\*\*\*

IMPLND 11	0.6	COPY 1	15
RCHRES 1	1	COPY 501	17

NETWORK

<-Volume->	<-Grp>	<-Member->	<--Mult-->	Tran	<-Target vols>	<-Grp>	<-Member->	***
<Name> #		<Name> #	#	<-factor->	strg	<Name> #	#	<Name> # #
COPY 501	OUTPUT	MEAN	1	1	48.4	DISPLY	1	INPUT TIMSER 1

<-Volume->	<-Grp>	<-Member->	<--Mult-->	Tran	<-Target vols>	<-Grp>	<-Member->	***
<Name> #		<Name> #	#	<-factor->	strg	<Name> #	#	<Name> # #

RCHRES

GEN-INFO

RCHRES	Name	Nexits	Unit	Systems	Printer	***
# - #	<----->	<---->	User	T-series	Engl Metr LKFG	***
			in	out		***
1	Trapezoidal Pond-005	2	1	1 1	28 0 1	

END GEN-INFO

\*\*\* Section RCHRES\*\*\*

ACTIVITY

<PLS >	*****	Active Sections	*****								
# - #	HYFG	ADFG	CNFG	HTFG	SDFG	GQFG	OXFG	NUFG	PKFG	PHFG	***
1	1	0	0	0	0	0	0	0	0	0	

END ACTIVITY

PRINT-INFO

<PLS >	*****	Print-flags	*****	PIVL	PYR	*****							
# - #	HYDR	ADCA	CONS	HEAT	SED	GQL	OXRX	NUTR	PLNK	PHCB	PIVL	PYR	*****
1	4	0	0	0	0	0	0	0	0	0	1	9	

END PRINT-INFO

HYDR-PARM1

RCHRES	Flags for each HYDR Section	***	ODGTFG for each	FUNCT for each	***
# - #	VC A1 A2 A3	ODFVFG for each	*** possible exit	*** possible exit	possible exit
	FG FG FG FG	* * * * *	* * * * *	* * * * *	* * * * *
1	0 1 0 0	4 5 0 0 0	0 0 0 0 0	2 2 2 2 2	

END HYDR-PARM1

HYDR-PARM2

# - #	FTABNO	LEN	DELTH	STCOR	KS	DB50	***
<----->	<----->	<----->	<----->	<----->	<----->	<----->	***
1	1	0.02	0.0	0.0	0.5	0.0	

END HYDR-PARM2

HYDR-INIT

RCHRES	Initial conditions for each HYDR section	***
# - #	*** VOL	Initial value of COLIND
	*** ac-ft	for each possible exit
		Initial value of OUTDGT
		for each possible exit
1	0	4.0 5.0 0.0 0.0 0.0

END HYDR-INIT

END RCHRES

SPEC-ACTIONS

END SPEC-ACTIONS

FTABLES

FTABLE

1

91 5

Depth (ft)	Area (acres)	Volume (acre-ft)	Outflow1 (cfs)	Outflow2 (cfs)	Velocity (ft/sec)	Travel Time*** (Minutes)***
0.000000	0.019743	0.000000	0.000000	0.000000		
0.033333	0.020022	0.000663	0.000000	0.101528		
0.066667	0.020302	0.001335	0.000000	0.101528		
0.100000	0.020583	0.002016	0.000000	0.101528		
0.133333	0.020864	0.002707	0.000000	0.101528		
0.166667	0.021145	0.003407	0.000000	0.101528		
0.200000	0.021426	0.004117	0.000000	0.101528		
0.233333	0.021709	0.004836	0.000000	0.101528		
0.266667	0.021991	0.005564	0.000000	0.101528		
0.300000	0.022274	0.006302	0.000000	0.101528		
0.333333	0.022557	0.007049	0.000000	0.101528		
0.366667	0.022841	0.007806	0.000000	0.101528		
0.400000	0.023125	0.008572	0.000000	0.101528		
0.433333	0.023410	0.009347	0.000000	0.101528		
0.466667	0.023695	0.010132	0.000000	0.101528		
0.500000	0.023981	0.010927	0.000000	0.101528		
0.533333	0.024267	0.011731	0.000000	0.101528		
0.566667	0.024553	0.012545	0.000000	0.101528		
0.600000	0.024840	0.013368	0.000000	0.101528		
0.633333	0.025127	0.014201	0.000000	0.101528		
0.666667	0.025415	0.015043	0.000000	0.101528		
0.700000	0.025703	0.015895	0.000000	0.101528		
0.733333	0.025991	0.016757	0.000000	0.101528		
0.766667	0.026280	0.017628	0.000000	0.101528		
0.800000	0.026570	0.018509	0.000000	0.101528		
0.833333	0.026860	0.019399	0.000000	0.101528		
0.866667	0.027150	0.020299	0.000000	0.101528		
0.900000	0.027440	0.021209	0.000000	0.101528		
0.933333	0.027731	0.022129	0.000000	0.101528		
0.966667	0.028023	0.023058	0.000000	0.101528		
1.000000	0.028315	0.023997	0.000000	0.101528		
1.033333	0.028607	0.024946	0.000000	0.101528		
1.066667	0.028900	0.025904	0.000000	0.101528		
1.100000	0.029193	0.026872	0.000000	0.101528		
1.133333	0.029487	0.027850	0.000000	0.101528		
1.166667	0.029781	0.028838	0.000000	0.101528		
1.200000	0.030076	0.029836	0.000000	0.101528		
1.233333	0.030371	0.030843	0.000000	0.101528		
1.266667	0.030666	0.031860	0.000000	0.101528		
1.300000	0.030962	0.032887	0.000000	0.101528		
1.333333	0.031258	0.033924	0.000000	0.101528		
1.366667	0.031555	0.034971	0.000000	0.101528		
1.400000	0.031852	0.036028	0.000000	0.101528		
1.433333	0.032149	0.037095	0.000000	0.101528		
1.466667	0.032447	0.038171	0.000000	0.101528		
1.500000	0.032746	0.039258	0.000000	0.101528		
1.533333	0.033044	0.040354	0.000000	0.101528		
1.566667	0.033344	0.041461	0.000000	0.101528		
1.600000	0.033643	0.042577	0.000000	0.101528		
1.633333	0.033943	0.043704	0.000000	0.101528		
1.666667	0.034244	0.044840	0.000000	0.101528		
1.700000	0.034545	0.045987	0.000000	0.101528		
1.733333	0.034846	0.047143	0.000000	0.101528		
1.766667	0.035148	0.048310	0.000000	0.101528		
1.800000	0.035450	0.049487	0.000000	0.101528		
1.833333	0.035753	0.050673	0.000000	0.101528		
1.866667	0.036056	0.051870	0.000000	0.101528		
1.900000	0.036360	0.053077	0.000000	0.101528		
1.933333	0.036664	0.054294	0.000000	0.101528		
1.966667	0.036968	0.055521	0.000000	0.101528		
2.000000	0.037273	0.056759	0.000000	0.101528		
2.033333	0.037578	0.058006	0.096853	0.101528		
2.066667	0.037884	0.059264	0.273695	0.101528		
2.100000	0.038190	0.060532	0.502178	0.101528		
2.133333	0.038496	0.061810	0.771465	0.101528		

2.166667	0.038803	0.063098	1.074270	0.101528
2.200000	0.039111	0.064397	1.404464	0.101528
2.233333	0.039418	0.065705	1.756250	0.101528
2.266667	0.039727	0.067025	2.123824	0.101528
2.300000	0.040035	0.068354	2.501261	0.101528
2.333333	0.040344	0.069694	2.882519	0.101528
2.366667	0.040654	0.071044	3.261505	0.101528
2.400000	0.040964	0.072404	3.632201	0.101528
2.433333	0.041274	0.073774	3.988826	0.101528
2.466667	0.041585	0.075155	4.326027	0.101528
2.500000	0.041896	0.076547	4.639092	0.101528
2.533333	0.042208	0.077949	4.924197	0.101528
2.566667	0.042520	0.079361	5.178660	0.101528
2.600000	0.042833	0.080783	5.401220	0.101528
2.633333	0.043145	0.082216	5.592337	0.101528
2.666667	0.043459	0.083660	5.754494	0.101528
2.700000	0.043773	0.085113	5.892534	0.101528
2.733333	0.044087	0.086578	6.013989	0.101528
2.766667	0.044402	0.088053	6.205051	0.101528
2.800000	0.044717	0.089538	6.338508	0.101528
2.833333	0.045032	0.091034	6.469213	0.101528
2.866667	0.045348	0.092540	6.597328	0.101528
2.900000	0.045664	0.094057	6.723003	0.101528
2.933333	0.045981	0.095584	6.846371	0.101528
2.966667	0.046299	0.097122	6.967555	0.101528
3.000000	0.046616	0.098671	7.086668	0.101528

END FTABLE 1

END FTABLES

EXT SOURCES

<-Volume->	<Member>	SsysSgap	<--Mult-->	Tran	<-Target vols>	<-Grp>	<-Member->	***	
<Name>	#	<Name>	#	tem strg	<-factor-->	strg	<Name>	# #	***
WDM	2	PREC		ENGL	1		PERLND	1 999	EXTNL PREC
WDM	2	PREC		ENGL	1		IMPLND	1 999	EXTNL PREC
WDM	1	EVAP		ENGL	1		PERLND	1 999	EXTNL PETINP
WDM	1	EVAP		ENGL	1		IMPLND	1 999	EXTNL PETINP

END EXT SOURCES

EXT TARGETS

<-Volume->	<-Grp>	<-Member->	<--Mult-->	Tran	<-Volume->	<Member>	Tsys	Tgap	Amd	***
<Name>	#	<Name>	#	#<-factor-->	strg	<Name>	#	<Name>	tem strg	strg***
RCHRES	1	HYDR	RO	1 1	1	WDM	1000	FLOW	ENGL	REPL
RCHRES	1	HYDR	O	1 1	1	WDM	1001	FLOW	ENGL	REPL
RCHRES	1	HYDR	O	2 1	1	WDM	1002	FLOW	ENGL	REPL
RCHRES	1	HYDR	STAGE	1 1	1	WDM	1003	STAG	ENGL	REPL
COPY	1	OUTPUT	MEAN	1 1	48.4	WDM	701	FLOW	ENGL	REPL
COPY	501	OUTPUT	MEAN	1 1	48.4	WDM	801	FLOW	ENGL	REPL

END EXT TARGETS

MASS-LINK

<Volume>	<-Grp>	<-Member->	<--Mult-->	<Target>	<-Grp>	<-Member->	***
<Name>		<Name>	# #<-factor-->	<Name>		<Name>	# #***
MASS-LINK			5				
IMPLND	IWATER	SURO	0.083333	RCHRES	INFLOW	IVOL	
END MASS-LINK			5				
MASS-LINK			15				
IMPLND	IWATER	SURO	0.083333	COPY	INPUT	MEAN	
END MASS-LINK			15				
MASS-LINK			17				
RCHRES	OFLOW	OVOL	1	COPY	INPUT	MEAN	
END MASS-LINK			17				

END MASS-LINK

END RUN

*Predeveloped HSPF Message File*

*Mitigated HSPF Message File*

## *Disclaimer*

### *Legal Notice*

This program and accompanying documentation are provided 'as-is' without warranty of any kind. The entire risk regarding the performance and results of this program is assumed by End User. Clear Creek Solutions Inc. and the governmental licensee or sublicensees disclaim all warranties, either expressed or implied, including but not limited to implied warranties of program and accompanying documentation. In no event shall Clear Creek Solutions Inc. be liable for any damages whatsoever (including without limitation to damages for loss of business profits, loss of business information, business interruption, and the like) arising out of the use of, or inability to use this program even if Clear Creek Solutions Inc. or their authorized representatives have been advised of the possibility of such damages. Software Copyright © by : Clear Creek Solutions, Inc. 2005-2024; All Rights Reserved.

Clear Creek Solutions, Inc.  
6200 Capitol Blvd. Ste F  
Olympia, WA. 98501  
Toll Free 1(866)943-0304  
Local (360)943-0304

[www.clearcreeksolutions.com](http://www.clearcreeksolutions.com)

# **CONVEYANCE CALCULATIONS**



# 18111-R-Calc-Voltage Park (Conveyance North Yard 3rd Submittal)-2024-06-28

BARGHAUSEN CONSULTING ENGINEERS - PIPE FLOW CALCULATOR  
using the Rational Method & Mannings Equation for 25 year storm event

JOB NAME: Voltage Park North Utility Yard  
JOB#: 18111  
FILE NO.:

**Total Site Area**  
0.38

C=	0.9	n=	0.012
d=	12	Tc=	6.3

A= Contributing Area (Ac)	Qd= Design Flow (cfs)
C= Runoff Coefficient	Qf= Full Capacity Flow (cfs)
Tc= Time of Concentration (min)	Vd= Velocity at Design Flow (fps)
I= Intensity at Tc (in/hr)	Vf= Velocity at Full Flow (fps)
d= Diameter of Pipe (in)	s= Slope of pipe (%)
L= Length of Pipe (ft)	n= Manning Roughness Coefficient
D= Water Depth at Qd (in)	Tt= Travel Time at Vd (min)

COEFFICIENTS FOR THE RATIONAL METHOD "Ir"-EQUATION				
STORM	Ar	Br	PRECIP=	
				<b>3.5</b>
2YR	1.58	0.58	Ar=	<b>2.66</b>
10YR	2.44	0.64	Br=	<b>0.65</b>
25YR	2.66	0.65		
50YR	2.75	0.65		
100YR	2.61	0.63		

	FROM	TO	A	s	L	d	Tc	n	C	SUM A	A*C	SUM A*C	I	Qd	Qf	Qd/Qf	D/d	D	Vf	Vd	Tt
TRUE	=====	=====	=====	=====	=====	=====	=====	=====	=====	=====	=====	=====	=====	=====	=====	=====	=====	=====	=====	=====	=====
FALSE	SD4	SD5	0.05	1.00	86	6	6.3	0.012	0.9	0.05	0.05	0.05	2.81	0.13	0.61	<b>0.208</b>	0.307	1.84	3.10	2.43	0.59
FALSE	SD5	SD6	0.00	1.00	10	6	6.9	0.012	0.9	0.05	0.00	0.05	2.66	0.12	0.61	<b>0.197</b>	0.297	1.78	3.10	2.39	0.07
FALSE	SD6	SD7	0.00	1.00	110	6	7.0	0.012	0.9	0.05	0.00	0.05	2.64	0.12	0.61	<b>0.195</b>	0.296	1.78	3.10	2.39	0.77
FALSE	SD7	SD1	0.33	6.05	84	8	7.7	0.012	0.9	0.38	0.30	0.34	2.46	0.84	3.22	<b>0.262</b>	0.349	2.80	9.23	7.77	0.18
FALSE	SD1	SD3	0.00	12.00	80	8	7.9	0.012	0.9	0.38	0.00	0.34	2.43	0.83	4.53	<b>0.183</b>	0.287	2.29	13.00	9.85	0.14
FALSE	SD3	SD11	0.00	1.00	34	8	8.0	0.012	0.9	0.38	0.00	0.34	2.40	0.82	1.31	<b>0.628</b>	0.583	4.66	3.75	3.98	0.14
FALSE	SD11	SD2	0.00	1.57	135	8	8.2	0.012	0.9	0.38	0.00	0.34	2.37	0.81	1.64	<b>0.495</b>	0.497	3.98	4.70	4.72	0.48
TRUE																					
TRUE																					
TRUE																					
TRUE																					
TRUE																					
TRUE																					
TRUE																					
TRUE																					
TRUE																					

# 18111-R-Calc-Voltage Park (Conveyance South Yard 3rd Submittal)-2024-06-28

BARGHAUSEN CONSULTING ENGINEERS - PIPE FLOW CALCULATOR  
using the Rational Method & Mannings Equation for 25 year storm event

JOB NAME: Voltage Park South Utility Yard  
JOB#: 18111  
FILE NO.:

**Total Site Area**  
0.21

C=	0.9	n=	0.012
d=	12	Tc=	6.3

A= Contributing Area (Ac)	Qd= Design Flow (cfs)
C= Runoff Coefficient	Qf= Full Capacity Flow (cfs)
Tc= Time of Concentration (min)	Vd= Velocity at Design Flow (fps)
I= Intensity at Tc (in/hr)	Vf= Velocity at Full Flow (fps)
d= Diameter of Pipe (in)	s= Slope of pipe (%)
L= Length of Pipe (ft)	n= Manning Roughness Coefficient
D= Water Depth at Qd (in)	Tt= Travel Time at Vd (min)

COEFFICIENTS FOR THE RATIONAL METHOD "Ir"-EQUATION				
STORM	Ar	Br	PRECIP=	
2YR	1.58	0.58	Ar=	<b>3.5</b>
10YR	2.44	0.64	Br=	<b>2.66</b>
25YR	2.66	0.65		
50YR	2.75	0.65		
100YR	2.61	0.63		

	FROM	TO	A	s	L	d	Tc	n	C	SUM A	A*C	SUM A*C	I	Qd	Qf	Qd/Qf	D/d	D	Vf	Vd	Tt
TRUE	=====	=====	=====	=====	=====	=====	=====	=====	=====	=====	=====	=====	=====	=====	=====	=====	=====	=====	=====	=====	=====
FALSE	SD8	SD10	0.12	7.50	77	8	6.3	0.012	0.9	0.12	0.11	0.11	2.81	0.30	3.58	<b>0.085</b>	0.195	1.56	10.28	5.86	0.22
FALSE	SD10	SD12	0.09	4.50	39	8	6.5	0.012	0.9	0.21	0.08	0.19	2.75	0.52	2.78	<b>0.187</b>	0.290	2.32	7.96	6.07	0.11
TRUE																					
TRUE																					
TRUE																					
TRUE																					
TRUE																					
TRUE																					
TRUE																					
TRUE																					
TRUE																					
TRUE																					
TRUE																					
TRUE																					
TRUE																					
TRUE																					
TRUE																					
TRUE																					
TRUE																					

## **APPENDIX C**

---

# Stormwater Pollution Prevention Plan

**For**  
Centeris Voltage Park

**Prepared For**  
Benaroya Capital, LLC  
9675 SE 36<sup>th</sup> Avenue  
Suite 115  
Mercer Island, WA 9040

<b>Owner</b>	<b>Developer</b>	<b>Operator/Contractor</b>
Benaroya Capital, LLC 9675 SE 36 <sup>th</sup> Avenue Mercer Island, WA 98040	Benaroya Capital, LLC 9675 SE 36 <sup>th</sup> Avenue Mercer Island, WA 98040	TBD

**Project Site Location**  
1023 39<sup>th</sup> Avenue SW  
Puyallup, WA 98374

**Certified Erosion and Sediment Control Lead**  
TBD

**SWPPP Prepared By**  
Barghausen Consulting Engineers, Inc.  
18215 - 72nd Avenue South  
Kent, WA 98032  
(425) 251-6222  
Cara Visintainer, PE

**SWPPP Preparation Date**  
February 2, 2024

**Project Construction Dates**  
February 2024 – August 2024

## Contents

1.0	Introduction.....	1
2.0	Site Description .....	3
2.1	Existing Conditions .....	3
2.2	Proposed Construction Activities .....	3
3.0	Construction Stormwater BMPs.....	5
3.1	The 14 BMP Elements.....	5
3.1.1	Element #1 – Mark Clearing Limits .....	5
3.1.2	Element #2 – Establish Construction Access.....	5
3.1.3	Element #3 – Control Flow Rates .....	6
3.1.4	Element #4 – Install Sediment Controls .....	6
3.1.5	Element #5 – Stabilize Soils.....	7
3.1.6	Element #6 – Protect Slopes.....	8
3.1.7	Element #7 – Protect Drain Inlets .....	8
3.1.8	Element #8 – Stabilize Channels and Outlets .....	9
3.1.9	Element #9 – Control Pollutants.....	10
3.1.10	Element #10 – Control Dewatering .....	10
3.1.11	Element #11 – Maintain BMPs.....	11
3.1.12	Element #12 – Manage the Project.....	11
3.1.13	Element #13 – Construction Stormwater Chemical Treatment.....	14
3.1.14	Element #14 – Construction Stormwater Filtration .....	19
3.2	Site Specific BMPs .....	21
4.0	Construction Phasing and BMP Implementation .....	22
5.0	Pollution Prevention Team .....	23
5.1	Roles and Responsibilities.....	23
5.2	Team Members.....	24
6.0	Site Inspections and Monitoring.....	25
6.1	Site Inspection .....	25
6.1.1	Site Inspection Frequency.....	25
6.1.2	Site Inspection Documentation .....	25
6.2	Stormwater Quality Monitoring.....	26
6.2.1	Turbidity Sampling .....	26
6.2.2	pH Sampling .....	27
7.0	Reporting and Recordkeeping .....	28
7.1	Recordkeeping.....	28
7.1.1	Site Log Book.....	28
7.1.2	Records Retention .....	28
7.1.3	Access to Plans and Records .....	28
7.1.4	Updating the SWPPP.....	28
7.2	Reporting .....	29
7.2.1	Discharge Monitoring Reports.....	29
7.2.2	Notification of Noncompliance.....	29

- Appendix A Site Plans**
- Appendix B Construction BMPs**
- Appendix C Alternative BMPs**
- Appendix D General Permit**
- Appendix E Site Inspection Forms (and Site Log)**
- Appendix F Engineering Calculations**

## 1.0 Introduction

This Stormwater Pollution Prevention Plan (SWPPP) has been prepared as part of the NPDES stormwater permit requirements for the Centeris Voltage Park project Puyallup, Washington. The proposed site is at 1023 39th Avenue SE Puyallup, Washington.

Construction activities will include installation of sediment and erosion control Best Management Practices (BMPs), construction of new mechanical and electrical infrastructure, and stormwater facilities.

The purpose of this SWPPP is to describe the proposed construction activities and all temporary and permanent erosion and sediment control (TESC) measures, pollution prevention measures, inspection/monitoring activities, and recordkeeping that will be implemented during the proposed construction project. The objectives of the SWPPP are to:

1. Implement Best Management Practices (BMPs) to prevent erosion and sedimentation, and to identify, reduce, eliminate or prevent stormwater contamination and water pollution from construction activity.
2. Prevent violations of surface water quality, ground water quality, or sediment management standards.
3. Prevent, during the construction phase, adverse water quality impacts including impacts on beneficial uses of the receiving water by controlling peak flow rates and volumes of stormwater runoff at the Permittee's outfalls and downstream of the outfalls.

This SWPPP was prepared using the Ecology SWPPP Template downloaded from the Ecology website. This SWPPP was prepared based on the requirements set forth in the Construction Stormwater General Permit, *Stormwater Management Manual for Western Washington*. The report is divided into seven main sections with several appendices that include stormwater related reference materials. The topics presented in the each of the main sections are:

- Section 1 – INTRODUCTION. This section provides a summary description of the project, and the organization of the SWPPP document.
- Section 2 – SITE DESCRIPTION. This section provides a detailed description of the existing site conditions, proposed construction activities, and calculated stormwater flow rates for existing conditions and post-construction conditions.
- Section 3 – CONSTRUCTION BMPs. This section provides a detailed description of the BMPs to be implemented based on the 14 required elements of the SWPPP.

- Section 4 – CONSTRUCTION PHASING AND BMP IMPLEMENTATION. This section provides a description of the timing of the BMP implementation in relation to the project schedule.
- Section 5 – POLLUTION PREVENTION TEAM. This section identifies the appropriate contact names (emergency and non-emergency), monitoring personnel, and the onsite temporary erosion and sedimentation control inspector
- Section 6 – INSPECTION AND MONITORING. This section provides a description of the inspection and monitoring requirements such as the parameters of concern to be monitored, sample locations, sample frequencies, and sampling methods for all stormwater discharge locations from the site.
- Section 7 – RECORDKEEPING. This section describes the requirements for documentation of the BMP implementation, site inspections, monitoring results, and changes to the implementation of certain BMPs due to site factors experienced during construction.

Supporting documentation and standard forms are provided in the following Appendices:

- Appendix A – Site Plans
- Appendix B – Construction BMPs
- Appendix C – Alternative BMPs
- Appendix D – General Permit
- Appendix E – Site Inspection Forms (and Site Log)
- Appendix F – Engineering Calculations



## 2.0 Site Description

### 2.1 Existing Conditions

The site is approximately 77 acres in size and is currently developed with buildings, paving, parking areas, utilities, and landscaping. The existing site is irregular in shape and contains several buildings and existing data center facilities. The site was initially developed back in the 1980s. The majority of the subject property consists of impervious surfaces (buildings and asphalt pavement) surrounded by maintained lawn and ornamental, non-native landscaping. The undeveloped forested portions of the site contain fir and maple trees. The site is bound on the north and east by parcels owned by Pierce College, to the south by 39<sup>th</sup> Avenue SE and to the west by an existing senior living facility. Site soils in the area of redevelopment consist of primarily of Kapowsin gravelly ashy loam and Indianola loamy sand. Previous wetland investigations identified potential wetlands on the site, none of which are affected by the new mechanical or electrical infrastructure. The site is not located within any mapped floodplain. Please refer to the exhibits within Appendix A of this report.

The site is sloped to the northwest with elevations ranging from 545 along the eastern border to 450 at the northwest corner. A developed stormwater conveyance system exists consisting of ditches, catch basins, and stormwater pipes that collect and convey runoff from the parking areas and buildings. Stormwater flows to the northwest into a small onsite pond which flows into Bradley Lake. No drainage or erosion issues were reported or noted in our site reconnaissance.

### 2.2 Proposed Construction Activities

This project will install new mechanical and electrical infrastructure to support new data center tenant loads. The project will include the addition of a new medium voltage feeder from the existing PSE sub-station to the data center building and the addition of new cooling equipment and electrical equipment.

Stormwater runoff rates and volumes were calculated using WWHM hydrology model.

The following summarizes details regarding site areas:

▪ Total site area:	77.0 ± acres
▪ Percent impervious area before construction:	75%
▪ Percent impervious area after construction:	75%
▪ Percent pervious area after construction:	25%
▪ Native Vegetation to be retained:	19 acres (25%)
▪ Disturbed area during construction:	0.80± acres
▪ Disturbed area that is characterized as impervious (i.e., access roads, staging, parking):	0.48 acres
▪ Cut quantity:	370 cy
▪ Fill quantity:	1,430 cy
▪ Max Cut/Fill Depth	4 ± feet

All stormwater flow calculations are provided in Appendix F.

## **3.0 Construction Stormwater BMPs**

### **3.1 The 14 BMP Elements**

#### **3.1.1 Element #1 – Preserve Vegetation/Mark Clearing Limits**

To protect adjacent properties and to reduce the area of soil exposed to construction, the limits of construction will be clearly marked before land-disturbing activities begin. Areas that are to be preserved shall be clearly delineated, both in the field and on the plans. The BMPs relevant to marking the clearing limits that will be applied for this project include:

- Preserving Natural Vegetation (BMP C101)
- High Visibility Plastic or Metal Fence (BMP C103)

The clearing limits shall be as shown on the plans and all vegetation outside of the clearing limits preserved. Native topsoil will be preserved in the undisturbed areas of the site.

Alternate BMPs for marking clearing limits are included in Appendix C as a quick reference tool for the onsite inspector in the event the BMP(s) listed above are deemed ineffective or inappropriate during construction to satisfy the requirements set forth in the General NPDES Permit (Appendix D). To avoid potential erosion and sediment control issues that may cause a violation(s) of the NPDES Construction Stormwater permit (as provided in Appendix D), the Certified Erosion and Sediment Control Lead will promptly initiate the implementation of one or more of the alternative BMPs listed in Appendix C after the first sign that existing BMPs are ineffective or failing.

#### **3.1.2 Element #2 – Establish Construction Access**

Construction access or activities occurring on unpaved areas shall be minimized, yet where necessary, access points shall be stabilized to minimize the tracking of sediment onto public roads, and wheel washing, street sweeping, and street cleaning shall be employed to prevent sediment from entering state waters. All wash wastewater shall be controlled on site. The specific BMPs related to establishing construction access that will be used on this project include:

- Stabilized Construction Entrance (BMP C105)
- Construction Haul Road (BMP C107)
- The roads shall be swept daily should sediment collect on them. Wheel washing (BMP C106), if needed, shall occur at locations where the sediment will be retained on site.

Alternate construction access BMPs are included in Appendix C as a quick reference tool for the onsite inspector in the event the BMP(s) listed above are deemed ineffective or inappropriate during construction to satisfy the requirements set forth in the General NPDES Permit

(Appendix D). To avoid potential erosion and sediment control issues that may cause a violation(s) of the NPDES Construction Stormwater permit (as provided in Appendix D), the Certified Erosion and Sediment Control Lead will promptly initiate the implementation of one or more of the alternative BMPs listed in Appendix C after the first sign that existing BMPs are ineffective or failing.

### **3.1.3 Element #3 – Control Flow Rates**

In order to protect the properties and waterways downstream of the project site, stormwater discharges from the site will be controlled and contained onsite.

The project site is located west of the Cascade Mountain Crest. As such, the project must comply with Minimum Requirement 7.

In general, discharge rates of stormwater from the site will be controlled where increases in impervious area or soil compaction during construction could lead to downstream erosion, or where necessary to meet local agency stormwater discharge requirements (e.g., discharge to combined sewer systems).

Alternate flow control BMPs are included in Appendix C as a quick reference tool for the onsite inspector in the event the BMP(s) listed above are deemed ineffective or inappropriate during construction to satisfy the requirements set forth in the General NPDES Permit (Appendix D). To avoid potential erosion and sediment control issues that may cause a violation(s) of the NPDES Construction Stormwater permit (as provided in Appendix D), the Certified Erosion and Sediment Control Lead will promptly initiate the implementation of one or more of the alternative BMPs listed in Appendix C after the first sign that existing BMPs are ineffective or failing.

### **3.1.4 Element #4 – Install Sediment Controls**

All stormwater runoff from disturbed areas shall be captured by an interceptor swale and conveyed through an appropriate sediment removal BMP before leaving the construction site or prior to being discharged to the downstream drainage course. The specific BMPs to be used for controlling sediment on this project include:

- Silt Fence (BMP C233)

A silt fence shall be installed along the downstream perimeter of the proposed site.

In addition, sediment will be removed from paved areas in and adjacent to construction work areas manually or using mechanical sweepers, as needed, to minimize tracking of sediments on vehicle tires away from the site and to minimize washoff of sediments from adjacent streets in runoff.

Whenever possible, sediment-laden water shall be discharged into relatively level, vegetated areas onsite (BMP C240 paragraph 5, page 4-102). (Note: Vegetated wetlands shall not be used for this purpose).

In some cases, sediment discharge in concentrated runoff can be controlled using permanent stormwater BMPs (e.g., infiltration swales, ponds, trenches). Sediment loads can limit the effectiveness of some permanent stormwater BMPs, such as those used for infiltration or biofiltration; however, those BMPs designed to remove solids by settling (wet ponds or sediment ponds) can be used during the construction phase. When permanent stormwater BMPs will be used to control sediment discharge during construction, the structure will be protected from excessive sedimentation with adequate erosion and sediment control BMPs. Any accumulated sediment shall be removed after construction is complete and the remainder of the site has been stabilized.

The following BMPs will be implemented as end-of-pipe sediment controls as required to meet permitted turbidity limits in the site discharge(s). Prior to the implementation of these technologies, sediment sources and erosion control and soil stabilization BMP efforts will be maximized to reduce the need for end-of-pipe sedimentation controls.

- Construction Stormwater Filtration (BMP C251)
- Construction Stormwater Chemical Treatment (BMP C 250) (implemented only with prior written approval from Ecology).

Alternate sediment control BMPs are included in Appendix C as a quick reference tool for the onsite inspector in the event the BMP(s) listed above are deemed ineffective or inappropriate during construction to satisfy the requirements set forth in the General NPDES Permit (Appendix D). To avoid potential erosion and sediment control issues that may cause a violation(s) of the NPDES Construction Stormwater permit (as provided in Appendix D), the Certified Erosion and Sediment Control Lead will promptly initiate the implementation of one or more of the alternative BMPs listed in Appendix C after the first sign that existing BMPs are ineffective or failing.

### **3.1.5 Element #5 – Stabilize Soils**

Exposed and unworked soils shall be stabilized with the application of effective BMPs to prevent erosion throughout the life of the project. The specific BMPs for soil stabilization that shall be used on this project include:

- Temporary and Permanent Seeding (BMP C120)
- Mulching (BMP C121)
- Plastic Covering (BMP C123)
- Dust Control (BMP C140)

Seeding shall occur on all areas to remain unworked pursuant to below. Dust shall be controlled if construction occurs during the summer. The project site is located west of the Cascade Mountain Crest. As such, no soils shall remain exposed and unworked for more than 7 days during the dry season (May 1 to September 30) and 2 days during the wet season (October 1 to April 30). Regardless of the time of year, all soils shall be stabilized at the end of the shift before a holiday or weekend if needed based on weather forecasts.

In general, cut and fill slopes will be stabilized as soon as possible and soil stockpiles will be temporarily covered with plastic sheeting. All stockpiled soils shall be stabilized from erosion, protected with sediment trapping measures, and where possible, be located away from storm drain inlets, waterways, and drainage channels.

Alternate soil stabilization BMPs are included in Appendix C as a quick reference tool for the onsite inspector in the event the BMP(s) listed above are deemed ineffective or inappropriate during construction to satisfy the requirements set forth in the General NPDES Permit (Appendix D). To avoid potential erosion and sediment control issues that may cause a violation(s) of the NPDES Construction Stormwater permit (as provided in Appendix D), the Certified Erosion and Sediment Control Lead will promptly initiate the implementation of one or more of the alternative BMPs listed in Appendix C after the first sign that existing BMPs are ineffective or failing.

### **3.1.6 Element #6 – Protect Slopes**

All cut and fill slopes will be designed, constructed, and protected in a manner that minimizes erosion.

The following specific BMPs will be used to protect slopes for this project:

- Temporary and Permanent Seeding (BMP C120)
- Nets and Blankets (BMP C122)

Temporary and permanent seeding shall be used at all exposed areas pursuant to the prior mentioned schedule (seasonal restrictions). Swales shall be used to convey stormwater from the steep slopes to the east of the site into the northern sediment trap. Nets shall be used to stabilize slopes on the eastern portion of the site with steep slopes.

Alternate slope protection BMPs are included in Appendix C as a quick reference tool for the onsite inspector in the event the BMP(s) listed above are deemed ineffective or inappropriate during construction to satisfy the requirements set forth in the General NPDES Permit (Appendix D). To avoid potential erosion and sediment control issues that may cause a violation(s) of the NPDES Construction Stormwater permit (as provided in Appendix D), the Certified Erosion and Sediment Control Lead will promptly initiate the implementation of one or more of the alternative BMPs listed in Appendix C after the first sign that existing BMPs are ineffective or failing.

### **3.1.7 Element #7 – Protect Drain Inlets**

All storm drain inlets and culverts made operable during construction shall be protected to prevent unfiltered or untreated water from entering the drainage conveyance system. However, the first priority is to keep all access roads clean of sediment and keep street wash water separate from entering storm drains until treatment can be provided. Storm Drain Inlet Protection (BMP C220) will be implemented for all drainage inlets and culverts that could

potentially be impacted by sediment-laden runoff on and near the project site. The following inlet protection measures will be applied on this project:

- Excavated Drop Inlet Protection
- Block and Gravel Drop Inlet Protection
- Gravel and Wire Drop Inlet Protection
- Catch Basin Filters
- Culvert Inlet Sediment Trap

Inlets shall be inspected weekly at a minimum and daily during storm events.

If the BMP options listed above are deemed ineffective or inappropriate during construction to satisfy the requirements set forth in the General NPDES Permit (Appendix D), or if no BMPs are listed above but deemed necessary during construction, the Certified Erosion and Sediment Control Lead shall implement one or more of the alternative BMP inlet protection options listed in Appendix C.

### **3.1.8 Element #8 – Stabilize Channels and Outlets**

Where site runoff is to be conveyed in channels, or discharged to a stream or some other natural drainage point, efforts will be taken to prevent downstream erosion. The specific BMPs for channel and outlet stabilization that shall be used on this project include:

- Outlet protection (BMP C209)
- Grass-Lined Channels (BMP C201)

The site runoff shall be discharged into the pond area of the permanent detention pond on site. The pond discharges to the existing drainage system located onsite.

The project site is located west of the Cascade Mountain Crest. As such, any temporary on-site conveyance channels shall be designed, constructed, and stabilized following BMP C201 to prevent erosion from the expected peak 10 minute velocity of flow from a Type 1A, 10-year, 24-hour recurrence interval storm for the developed condition. Alternatively, the 10-year, 1-hour peak flow rate indicated by an approved continuous runoff simulation model, increased by a factor of 1.6, shall be used. Stabilization, including armoring material, adequate to prevent erosion of outlets, adjacent streambanks, slopes, and downstream reaches shall be provided at the outlets of all conveyance systems.

Alternate channel and outlet stabilization BMPs are included in Appendix C as a quick reference tool for the onsite inspector in the event the BMP(s) listed above are deemed ineffective or inappropriate during construction to satisfy the requirements set forth in the General NPDES Permit (Appendix D). To avoid potential erosion and sediment control issues that may cause a violation(s) of the NPDES Construction Stormwater permit (as provided in Appendix D), the Certified Erosion and Sediment Control Lead will promptly initiate the implementation of one or

more of the alternative BMPs listed in Appendix C after the first sign that existing BMPs are ineffective or failing.

### **3.1.9 Element #9 – Control Pollutants**

All pollutants, including waste materials and demolition debris, that occur onsite shall be handled and disposed of in a manner that does not cause contamination of stormwater. Good housekeeping and preventative measures will be taken to ensure that the site will be kept clean, well organized, and free of debris. If required, BMPs to be implemented to control specific sources of pollutants are discussed below. Vehicles, construction equipment, and/or petroleum product storage/dispensing:

- All vehicles, equipment, and petroleum product storage/dispensing areas will be inspected regularly to detect any leaks or spills, and to identify maintenance needs to prevent leaks or spills.
- On-site fueling tanks and petroleum product storage containers shall include secondary containment.
- Spill prevention measures, such as drip pans, will be used when conducting maintenance and repair of vehicles or equipment.
- In order to perform emergency repairs on site, temporary plastic will be placed beneath and, if raining, over the vehicle.
- Contaminated surfaces shall be cleaned immediately following any discharge or spill incident.

Demolition:

- Storm drain inlets vulnerable to stormwater discharge carrying dust, soil, or debris will be protected using Storm Drain Inlet Protection (BMP C220 as described above for Element 7).

Concrete and grout:

- Concrete trucks shall not be washed out onto the ground.
- Process water and slurry resulting from concrete work will be prevented from entering the waters of the State by implementing Concrete Handling measures (BMP C151).

### **3.1.10 Element #10 – Control Dewatering**

All dewatering water from open cut excavation, tunneling, foundation work, trench, or underground vaults shall be discharged into a controlled conveyance system prior to discharge to the downstream drainage course. Channels will be stabilized, per Element #8. Clean, non-turbid dewatering water will be discharged directly into systems tributary to the receiving waters of the State in a manner that does not cause erosion, flooding, or a violation of State water quality standards in the receiving water. Highly turbid dewatering water from soils known or



suspected to be contaminated, or from use of construction equipment, will require additional monitoring and treatment as required for the specific pollutants based on the receiving waters into which the discharge is occurring. Such monitoring is the responsibility of the contractor.

However, the dewatering of soils known to be free of contamination will trigger BMPs to trap sediment and reduce turbidity. At a minimum, geotextile fabric socks/bags/cells will be used to filter this material. At this time no dewatering is anticipated on this site.

If project dewatering is proposed to be discharged to the City sewer system, a "Construction Site Dewatering Permit" must be obtained by the contractor. Contact city of Puyallup source Control Specialist, Eric Rogers, at 253-847-5523 for permit application.

Alternate dewatering control BMPs are included in Appendix C as a quick reference tool for the onsite inspector in the event the BMP(s) listed above are deemed ineffective or inappropriate during construction to satisfy the requirements set forth in the General NPDES Permit (Appendix D). To avoid potential erosion and sediment control issues that may cause a violation(s) of the NPDES Construction Stormwater permit (as provided in Appendix D), the Certified Erosion and Sediment Control Lead will promptly initiate the implementation of one or more of the alternative BMPs listed in Appendix C after the first sign that existing BMPs are ineffective or failing.

### **3.1.11 Element #11 – Maintain BMPs**

All temporary and permanent erosion and sediment control BMPs shall be maintained and repaired as needed to assure continued performance of their intended function. Maintenance and repair shall be conducted in accordance with each particular BMP's specifications (See 2005 SWMM WW, Vol II). Visual monitoring of the BMPs will be conducted at least once every calendar week and within 24 hours of any rainfall event that causes a discharge from the site. If the site becomes inactive, and is temporarily stabilized, the inspection frequency will be reduced to once every month.

All temporary erosion and sediment control BMPs shall be removed within 30 days after the final site stabilization is achieved or after the temporary BMPs are no longer needed. Trapped sediment shall be removed or stabilized on site. Disturbed soil resulting from removal of BMPs or vegetation shall be permanently stabilized.

### **3.1.12 Element #12 – Manage the Project**

Erosion and sediment control BMPs for this project have been designed based on the following principles:

- Design the project to fit the existing topography, soils, and drainage patterns.
- Emphasize erosion control rather than sediment control.
- Minimize the extent and duration of the area exposed.
- Keep runoff velocities low.

- Retain sediment on site.
- Thoroughly monitor site and maintain all ESC measures.
- Schedule major earthwork during the dry season.

In addition, project management will incorporate the key components listed below:

As this project site is located west of the Cascade Mountain Crest, the project will be managed according to the following key project components:

#### Phasing of Construction

- Revegetation of exposed areas and maintenance of that vegetation shall be an integral part of the clearing activities during each phase of construction, per the Scheduling BMP (C 162).

#### Seasonal Work Limitations

- From October 1 through April 30, clearing, grading, and other soil disturbing activities shall only be permitted if shown to the satisfaction of the local permitting authority that silt-laden runoff will be prevented from leaving the site through a combination of the following:
  - Site conditions including existing vegetative coverage, slope, soil type, and proximity to receiving waters; and
  - Limitations on activities and the extent of disturbed areas; and
  - Proposed erosion and sediment control measures.
- Based on the information provided and/or local weather conditions, the local permitting authority may expand or restrict the seasonal limitation on site disturbance.
- The following activities are exempt from the seasonal clearing and grading limitations:
  - Routine maintenance and necessary repair of erosion and sediment control BMPs;
  - Routine maintenance of public facilities or existing utility structures that do not expose the soil or result in the removal of the vegetative cover to soil; and
  - Activities where there is 100 percent infiltration of surface water runoff within the site in approved and installed erosion and sediment control facilities.

### Coordination with Utilities and Other Jurisdictions

- Care has been taken to coordinate with utilities, other construction projects, and the local jurisdiction in preparing this SWPPP and scheduling the construction work.

### Inspection and Monitoring

- All BMPs shall be inspected, maintained, and repaired as needed to assure continued performance of their intended function. Site inspections shall be conducted by a person who is knowledgeable in the principles and practices of erosion and sediment control. This person has the necessary skills to:
  - Assess the site conditions and construction activities that could impact the quality of stormwater, and
  - Assess the effectiveness of erosion and sediment control measures used to control the quality of stormwater discharges.
- A Certified Erosion and Sediment Control Lead shall be on-site or on-call at all times.
- Whenever inspection and/or monitoring reveals that the BMPs identified in this SWPPP are inadequate, due to the actual discharge of or potential to discharge a significant amount of any pollutant, appropriate BMPs or design changes shall be implemented as soon as possible.

### Maintaining an Updated Construction SWPPP

- This SWPPP shall be retained on-site or within reasonable access to the site.
- The SWPPP shall be modified whenever there is a change in the design, construction, operation, or maintenance at the construction site that has, or could have, a significant effect on the discharge of pollutants to waters of the state.
- The SWPPP shall be modified if, during inspections or investigations conducted by the owner/operator, or the applicable local or state regulatory authority, it is determined that the SWPPP is ineffective in eliminating or significantly minimizing pollutants in stormwater discharges from the site. The SWPPP shall be modified as necessary to include additional or modified BMPs designed to correct problems identified. Revisions to the SWPPP shall be completed within seven (7) days following the inspection.

### **3.1.13 Element #13 – Construction Stormwater Chemical Treatment**

Turbidity is difficult to control once fine particles are suspended in stormwater runoff from a construction site. Sedimentation ponds are effective at removing larger particulate matter by gravity settling, but are ineffective at removing smaller particulates such as clay and fine silt. Sediment ponds are typically designed to remove sediment no smaller than medium silt (0.02 mm). Chemical treatment may be used to reduce the turbidity of stormwater runoff.

Chemical treatment can reliably provide exceptional reductions of turbidity and associated pollutants. Very high turbidities can be reduced to levels comparable to what is found in streams during dry weather. Traditional BMPs used to control soil erosion and sediment loss from sites under development may not be adequate to ensure compliance with the water quality standard for turbidity in the receiving water. Chemical treatment may be required to protect streams from the impact of turbid stormwater discharges, especially when construction is to proceed through the wet season.

**Formal written approval from Ecology and the Local Permitting Authority is required for the use of chemical treatment regardless of site size. The intention to use Chemical Treatment shall be indicated on the Notice of Intent for coverage under the General Construction Permit. Chemical treatment systems should be designed as part of the Construction SWPPP, not after the fact. Chemical treatment may be used to correct problem sites in limited circumstances with formal written approval from Ecology and the Local Permitting Authority.**

The SEPA review authority must be notified at the application phase of the project review (or the time that the SEPA determination on the project is performed) that chemical treatment is proposed. If it is added after this stage, an addendum will be necessary and may result in project approval delay.

See Appendix II-B Vol. II, Ecology 2005 SWMMWW for background information on chemical treatment.

#### **Criteria for Chemical Treatment Product Use**

Chemically treated stormwater discharged from construction sites must be nontoxic to aquatic organisms. The following protocol shall be used to evaluate chemicals proposed for stormwater treatment at construction sites. Authorization to use a chemical in the field based on this protocol does not relieve the applicant from responsibility for meeting all discharge and receiving water criteria applicable to a site.

- Treatment chemicals must be approved by EPA for potable water use.
- Petroleum-based polymers are prohibited.
- Prior to authorization for field use, jar tests shall be conducted to demonstrate that turbidity reduction necessary to meet the receiving

water criteria can be achieved. Test conditions, including but not limited to raw water quality and jar test procedures, should be indicative of field conditions. Although these small-scale tests cannot be expected to reproduce performance under field conditions, they are indicative of treatment capability.

- Prior to authorization for field use, the chemically treated stormwater shall be tested for aquatic toxicity. Applicable procedures defined in Chapter 173-205 WAC, Whole Effluent Toxicity Testing and Limits, shall be used. Testing shall use stormwater from the construction site at which the treatment chemical is proposed for use or a water solution using soil from the proposed site.
- The proposed maximum dosage shall be at least a factor of five lower than the no observed effects concentration (NOEC).
- The approval of a proposed treatment chemical shall be conditional, subject to full-scale bioassay monitoring of treated stormwater at the construction site where the proposed treatment chemical is to be used.
- Treatment chemicals that have already passed the above testing protocol do not need to be reevaluated. Contact the Department of Ecology Regional Office for a list of treatment chemicals that have been evaluated and are currently approved for use.

### **Treatment System Design Considerations**

The design and operation of a chemical treatment system should take into consideration the factors that determine optimum, cost-effective performance. It may not be possible to fully incorporate all of the classic concepts into the design because of practical limitations at construction sites. Nonetheless, it is important to recognize the following:

- The right chemical must be used at the right dosage. A dosage that is either too low or too high will not produce the lowest turbidity. There is an optimum dosage rate. This is a situation where the adage "adding more is always better" is not the case.
- The coagulant must be mixed rapidly into the water to insure proper dispersion.
- A flocculation step is important to increase the rate of settling, to produce the lowest turbidity, and to keep the dosage rate as low as possible.
- Too little energy input into the water during the flocculation phase results in flocs that are too small and/or insufficiently dense. Too much energy can rapidly destroy floc as it is formed.

- Since the volume of the basin is a determinant in the amount of energy per unit volume, the size of the energy input system can be too small relative to the volume of the basin.
- Care must be taken in the design of the withdrawal system to minimize outflow velocities and to prevent floc discharge. The discharge should be directed through a physical filter such as a vegetated swale that would catch any unintended floc discharge.

### **Treatment System Design**

Chemical treatment systems shall be designed as batch treatment systems using either ponds or portable trailer-mounted tanks. Flow-through continuous treatment systems are not allowed at this time.

A chemical treatment system consists of the stormwater collection system (either temporary diversion or the permanent site drainage system), a storage pond, pumps, a chemical feed system, treatment cells, and interconnecting piping.

The treatment system shall use a minimum of two lined treatment cells. Multiple treatment cells allow for clarification of treated water while other cells are being filled or emptied. Treatment cells may be ponds or tanks. Ponds with constructed earthen embankments greater than six feet high require special engineering analyses. Portable tanks may also be suitable for some sites.

The following equipment should be located in an operations shed:

- the chemical injector;
- secondary containment for acid, caustic, buffering compound, and treatment chemical;
- emergency shower and eyewash, and
- monitoring equipment which consists of a pH meter and a turbidimeter.

### **Sizing Criteria**

The combination of the storage pond or other holding area and treatment capacity should be large enough to treat stormwater during multiple day storm events. It is recommended that at a minimum the storage pond or other holding area should be sized to hold 1.5 times the runoff volume of the 10-year, 24-hour storm event. Bypass should be provided around the chemical treatment system to accommodate extreme storm events. Runoff volume shall be calculated using the methods presented in Volume 3, Chapter 2. If no hydrologic analysis is required for the site, the Rational Method may be used.

Primary settling should be encouraged in the storage pond. A forebay with access for maintenance may be beneficial.

There are two opposing considerations in sizing the treatment cells. A larger cell is able to treat a larger volume of water each time a batch is processed. However, the larger the cell the longer the time required to empty the cell. A larger cell may also be less effective at flocculation and therefore require a longer settling time. The simplest approach to sizing the treatment cell is to multiply the allowable discharge flow rate times the desired drawdown time. A 4-hour drawdown time allows one batch per cell per 8-hour work period, given 1 hour of flocculation followed by two hours of settling.

The permissible discharge rate governed by potential downstream effect can be used to calculate the recommended size of the treatment cells. The following discharge flow rate limits shall apply:

- If the discharge is directly or indirectly to a stream, the discharge flow rate shall not exceed 50 percent of the peak flow rate of the 2-year, 24-hour event for all storm events up to the 10-year, 24-hour event.
- If discharge is occurring during a storm event equal to or greater than the 10-year, 24-hour event, the allowable discharge rate is the peak flow rate of the 10-year, 24-hour event.
- Discharge to a stream should not increase the stream flow rate by more than 10 percent.
- If the discharge is directly to a lake, a major receiving water listed in Appendix C of Volume I, or to an infiltration system, there is no discharge flow limit.
- If the discharge is to a municipal storm drainage system, the allowable discharge rate may be limited by the capacity of the public system. It may be necessary to clean the municipal storm drainage system prior to the start of the discharge to prevent scouring solids from the drainage system.
- Runoff rates shall be calculated using the methods presented in Volume 3, Chapter 2 for the pre-developed condition. If no hydrologic analysis is required for the site, the Rational Method may be used.

## Monitoring

The following monitoring shall be conducted. Test results shall be recorded on a daily log kept on site:

### Operational Monitoring

- pH, conductivity (as a surrogate for alkalinity), turbidity and temperature of the untreated stormwater
- Total volume treated and discharged
- Discharge time and flow rate
- Type and amount of chemical used for pH adjustment
- Amount of polymer used for treatment
- Settling time

### Compliance Monitoring

- pH and turbidity of the treated stormwater
- pH and turbidity of the receiving water

**Biomonitoring:** Treated stormwater shall be tested for acute (lethal) toxicity. Bioassays shall be conducted by a laboratory accredited by Ecology, unless otherwise approved by Ecology. **The performance standard for acute toxicity is no statistically significant difference in survival between the control and 100 percent chemically treated stormwater.**

Acute toxicity tests shall be conducted with the following species and protocols:

- Fathead minnow, *Pimephales promelas* (96 hour static-renewal test, method: EPA/600/4-90/027F). Rainbow trout, *Oncorhynchus mykiss* (96 hour static-renewal test, method: EPA/600/4-90/027F) may be used as a substitute for fathead minnow.
- Daphnid, *Ceriodaphnia dubia*, *Daphnia pulex*, or *Daphnia magna* (48 hour static test, method: EPA/600/4-90/027F).

All toxicity tests shall meet quality assurance criteria and test conditions in the most recent versions of the EPA test method and Ecology Publication # WO-R-95-80, Laboratory Guidance and Whole Effluent Toxicity Test Review Criteria.

Bioassays shall be performed on the *first* five batches and on every tenth batch thereafter, or as otherwise approved by Ecology. Failure to meet the performance standard shall be immediately reported to Ecology.

**Discharge Compliance:** Prior to discharge, each batch of treated stormwater must be sampled and tested for compliance with pH and turbidity limits. These limits may be established by the water quality standards or a site-specific discharge permit. Sampling and testing for other pollutants may also be necessary at some sites. Turbidity must be within 5 NTUs of the background turbidity. Background is measured in the receiving water, upstream



from the treatment process discharge point. pH must be within the range of 6.5 to 8.5 standard units and not cause a change in the pH of the receiving water of more than 0.2 standard units. It is often possible to discharge treated stormwater that has a lower turbidity than the receiving water and that matches the pH.

Treated stormwater samples and measurements shall be taken from the discharge pipe or another location representative of the nature of the treated stormwater discharge. Samples used for determining compliance with the water quality standards in the receiving water shall not be taken from the treatment pond prior to decanting. Compliance with the water quality standards is determined in the receiving water.

### **Operator Training**

Each contractor who intends to use chemical treatment shall be trained by an experienced contractor on an active site for at least 40 hours.

### **Standard BMPs**

Surface stabilization BMPs should be implemented on site to prevent significant erosion. All sites shall use a truck wheel wash to prevent tracking of sediment off site.

### **Sediment Removal and Disposal**

- Sediment shall be removed from the storage or treatment cells as necessary. Typically, sediment removal is required at least once during a wet season and at the decommissioning of the cells. Sediment remaining in the cells between batches may enhance the settling process and reduce the required chemical dosage.
- Sediment may be incorporated into the site away from drainages.

### **3.1.14 Element #14 – Construction Stormwater Filtration**

Filtration removes sediment from runoff originating from disturbed areas of the site.

Traditional BMPs used to control soil erosion and sediment loss from sites under development may not be adequate to ensure compliance with the water quality standard for turbidity in the receiving water. Filtration may be used in conjunction with gravity settling to remove sediment as small as fine silt (0.5 µm). The reduction in turbidity will be dependent on the particle size distribution of the sediment in the stormwater. In some circumstances, sedimentation and filtration may achieve compliance with the water quality standard for turbidity.

Unlike chemical treatment, the use of construction stormwater filtration does not require approval from Ecology.

Filtration may also be used in conjunction with polymer treatment in a portable system to assure capture of the flocculated solids.

## **Design and Installation Specifications – Background Information**

Filtration with sand media has been used for over a century to treat water and wastewater. The use of sand filtration for treatment of stormwater has developed recently, generally to treat runoff from streets, parking lots, and residential areas. The application of filtration to construction stormwater treatment is currently under development.

Two types of filtration systems may be applied to construction stormwater treatment: rapid and slow. Rapid sand filters are the typical system used for water and wastewater treatment. They can achieve relatively high hydraulic flow rates, on the order of 2 to 20 gpm/sf, because they have automatic backwash systems to remove accumulated solids. In contrast, slow sand filters have very low hydraulic rates, on the order of 0.02 gpm/sf, because they do not have backwash systems. To date, slow sand filtration has generally been used to treat stormwater. Slow sand filtration is mechanically simple in comparison to rapid sand filtration but requires a much larger filter area.

### **Filtration Equipment**

Sand media filters are available with automatic backwashing features that can filter to 50 µm particle size. Screen or bag filters can filter down to 5 µm. Fiber wound filters can remove particles down to 0.5 µm. Filters should be sequenced from the largest to the smallest pore opening. Sediment removal efficiency will be related to particle size distribution in the stormwater.

### **Treatment Process Description**

Stormwater is collected at interception point(s) on the site and is diverted to a sediment pond or tank for removal of large sediment and storage of the stormwater before it is treated by the filtration system. The stormwater is pumped from the trap, pond, or tank through the filtration system in a rapid sand filtration system. Slow sand filtration systems are designed as flow through systems using gravity.

If large volumes of concrete are being poured, pH adjustment may be necessary.

### **Maintenance Standards**

Rapid sand filters typically have automatic backwash systems that are triggered by a pre-set pressure drop across the filter. If the backwash water volume is not large or substantially more turbid than the stormwater stored in the holding pond or tank, backwash return to the pond or tank may be appropriate. However, land application or another means of treatment and disposal may be necessary.

- Screen, bag, and fiber filters must be cleaned and/or replaced when they become clogged.

- Sediment shall be removed from the storage and/or treatment ponds as necessary. Typically, sediment removal is required once or twice during a wet season and at the decommissioning of the ponds.

### **3.2 Site Specific BMPs**

Site specific BMPs are shown on the TESC Plan Sheets and Details in Appendix A. These site specific plan sheets will be updated annually.

## 4.0 Construction Phasing and BMP Implementation

The BMP implementation schedule will be driven by the construction schedule. The following provides a sequential list of the proposed construction schedule milestones and the corresponding BMP implementation schedule. The list contains key milestones such as wet season construction.

The BMP implementation schedule listed below is keyed to proposed phases of the construction project, and reflects differences in BMP installations and inspections that relate to wet season construction. The project site is located west of the Cascade Mountain Crest. As such, the dry season is considered to be from May 1 to September 30 and the wet season is considered to be from October 1 to April 30.

- Estimate of Construction start date: February 2024
- Estimate of Construction finish date: August 2024
- Mobilize equipment on site: \_\_\_\_\_
- Mobilize and store all ESC and soil stabilization products (store materials on hand BMP C150): \_\_\_\_\_
- Install ESC measures: \_\_\_\_\_
- Install stabilized construction entrance: \_\_\_\_\_
- Begin clearing and grubbing: \_\_\_\_\_
- Temporary erosion control measures (hydroseeding): \_\_\_\_\_
- Site inspections reduced to monthly: \_\_\_\_\_
- Begin concrete pour and implement BMP C151: \_\_\_\_\_
- Excavate and install new utilities and services (Phase 1): \_\_\_\_\_
- Complete utility construction: \_\_\_\_\_
- Begin implementing soil stabilization and sediment control BMPs throughout the site in preparation for wet season: \_\_\_\_\_
- **WET SEASON STARTS:** October 1, 2024

## 5.0 Pollution Prevention Team

### 5.1 Roles and Responsibilities

The pollution prevention team consists of personnel responsible for implementation of the SWPPP, including the following:

- Certified Erosion and Sediment Control Lead (CESCL) – primary contractor contact, responsible for site inspections (BMPs, visual monitoring, sampling, etc.); to be called upon in case of failure of any ESC measures.
- Resident Engineer – For projects with engineered structures only (sediment ponds/traps, sand filters, etc.): site representative for the owner that is the project's supervising engineer responsible for inspections and issuing instructions and drawings to the contractor's site supervisor or representative
- Emergency Ecology Contact – individual to be contacted at Ecology in case of emergency. Go to the following website to get the name and number for the Ecology contact information:  
<http://www.ecy.wa.gov/org.html>.
- Emergency Owner Contact – individual that is the site owner or representative of the site owner to be contacted in the case of an emergency.
- Non-Emergency Ecology Contact – individual that is the site owner or representative of the site owner than can be contacted if required.
- Monitoring Personnel – personnel responsible for conducting water quality monitoring; for most sites this person is also the Certified Erosion and Sediment Control Lead.

## 5.2 Team Members

Names and contact information for those identified as members of the pollution prevention team are provided in the following table.

Title	Name(s)	Phone Number
Certified Erosion and Sediment Control Lead (CESCL)	TBD	
Resident Engineer	Dan Balmelli	(425) 251-6222
Emergency Ecology Contact	Clay Keown	(360) 407-6048
Emergency Owner Contact		
Non-Emergency Ecology Contact		
Monitoring Personnel	TBD	

## 6.0 Site Inspections and Monitoring

Monitoring includes visual inspection, monitoring for water quality parameters of concern, and documentation of the inspection and monitoring findings in a site log book. A site log book will be maintained for all on-site construction activities and will include:

- A record of the implementation of the SWPPP and other permit requirements;
- Site inspections; and,
- Stormwater quality monitoring.

For convenience, the inspection form and water quality monitoring forms included in this SWPPP include the required information for the site log book. This SWPPP may function as the site log book if desired, or the forms may be separated and included in a separate site log book. However, if separated, the site log book but must be maintained on-site or within reasonable access to the site and be made available upon request to Ecology or the local jurisdiction.

### 6.1 Site Inspection

All BMPs will be inspected, maintained, and repaired as needed to assure continued performance of their intended function. The inspector will be a Certified Erosion and Sediment Control Lead (CESCL) per BMP C160. The name and contact information for the CESCL is provided in Section 5 of this SWPPP.

Site inspection will occur in all areas disturbed by construction activities and at all stormwater discharge points. Stormwater will be examined for the presence of suspended sediment, turbidity, discoloration, and oily sheen. The site inspector will evaluate and document the effectiveness of the installed BMPs and determine if it is necessary to repair or replace any of the BMPs to improve the quality of stormwater discharges. All maintenance and repairs will be documented in the site log book or forms provided in this document. All new BMPs or design changes will be documented in the SWPPP as soon as possible.

#### 6.1.1 Site Inspection Frequency

Site inspections will be conducted at least once a week and within 24 hours following any rainfall event which causes a discharge of stormwater from the site. For sites with temporary stabilization measures, the site inspection frequency can be reduced to once every month.

#### 6.1.2 Site Inspection Documentation

The site inspector will record each site inspection using the site log inspection forms provided in Appendix E. The site inspection log forms may be separated from this SWPPP document, but will be maintained on-site or within reasonable access to the site and be made available upon request to Ecology or the local jurisdiction.

## 6.2 Stormwater Quality Monitoring

### 6.2.1 Turbidity Sampling

Monitoring requirements for the proposed project will include either turbidity or water transparency sampling to monitor site discharges for water quality compliance with the 2019 Construction Stormwater General Permit (Appendix D). Sampling will be conducted at all discharge points at least once per calendar week.

Turbidity or transparency monitoring will follow the analytical methodologies described in Section S4 of the 2020 Construction Stormwater General Permit (Appendix D). The key benchmark values that require action are 25 NTU for turbidity (equivalent to 32 cm transparency) and 250 NTU for turbidity (equivalent to 6 cm transparency). If the 25 NTU benchmark for turbidity (equivalent to 32 cm transparency) is exceeded, the following steps will be conducted:

1. Ensure all BMPs specified in this SWPPP are installed and functioning as intended.
2. Assess whether additional BMPs should be implemented, and document revisions to the SWPPP as necessary.
3. Sample discharge location daily until the analysis results are less than 25 NTU (turbidity) or greater than 32 cm (transparency).

If the turbidity is greater than 25 NTU (or transparency is less than 32 cm) but less than 250 NTU (transparency greater than 6 cm) for more than 3 days, additional treatment BMPs will be implemented within 24 hours of the third consecutive sample that exceeded the benchmark.

If the 250 NTU benchmark for turbidity (or less than 6 cm transparency) is exceeded at any time, the following steps will be conducted:

1. Notify Ecology by phone within 24 hours of analysis (see Section 5.0 of this SWPPP for contact information).
2. Continue daily sampling until the turbidity is less than 25 NTU (or transparency is greater than 32 cm).
3. Initiate additional treatment BMPs such as off-site treatment, infiltration, filtration, and chemical treatment within 24 hours of the first 250 NTU exceedance.
4. Implement additional treatment BMPs as soon as possible, but within 7 days of the first 250 NTU exceedance.
5. Describe inspection results and remedial actions taken in the site log book and in monthly discharge monitoring reports as described in Section 7.0 of this SWPPP.



### 6.2.2 pH Sampling

Stormwater runoff will be monitored for pH starting on the first day of any activity that includes more than 40 yards of poured or recycled concrete, or after the application of "Engineered Soils" such as Portland cement treated base, cement kiln dust, or fly ash. This does not include fertilizers. For concrete work, pH monitoring will start the first day concrete is poured and continue until 3 weeks after the last pour. For engineered soils, the pH monitoring period begins when engineered soils are first exposed to precipitation and continue until the area is fully stabilized.

Stormwater samples will be collected daily from all points of discharge from the site and measured for pH using a calibrated pH meter, pH test kit, or wide range pH indicator paper. If the measured pH is 8.5 or greater, the following steps will be conducted:

1. Prevent the high pH water from entering storm drains or surface water.
2. Adjust or neutralize the high pH water if necessary using appropriate technology such as CO<sub>2</sub> sparging (liquid or dry ice).
3. Contact Ecology if chemical treatment other than CO<sub>2</sub> sparging is planned.

## **7.0 Reporting and Recordkeeping**

### **7.1 Recordkeeping**

#### **7.1.1 Site Log Book**

A site log book will be maintained for all on-site construction activities and will include:

- A record of the implementation of the SWPPP and other permit requirements;
- Site inspections; and,
- Stormwater quality monitoring.

For convenience, the inspection form and water quality monitoring forms included in this SWPPP include the required information for the site logbook.

#### **7.1.2 Records Retention**

Records of all monitoring information (site log book, inspection reports/checklists, etc.), this Stormwater Pollution Prevention Plan, and any other documentation of compliance with permit requirements will be retained during the life of the construction project and for a minimum of three years following the termination of permit coverage in accordance with permit condition S5.C.

#### **7.1.3 Access to Plans and Records**

The SWPPP, General Permit, Notice of Authorization letter, and Site Log Book will be retained on site or within reasonable access to the site and will be made immediately available upon request to Ecology or the local jurisdiction. A copy of this SWPPP will be provided to Ecology within 14 days of receipt of a written request for the SWPPP from Ecology. Any other information requested by Ecology will be submitted within a reasonable time. A copy of the SWPPP or access to the SWPPP will be provided to the public when requested in writing in accordance with Permit Condition S5.G.

#### **7.1.4 Updating the SWPPP**

In accordance with Conditions S3, S4.B, and S9.B.3 of the General Permit, this SWPPP will be modified if the SWPPP is ineffective in eliminating or significantly minimizing pollutants in stormwater discharges from the site or there has been a change in design, construction, operation, or maintenance at the site that has a significant effect on the discharge, or potential for discharge, of pollutants to the waters of the State. The SWPPP will be modified within seven days of determination based on inspection(s) that additional or modified BMPs are necessary to correct problems identified, and an updated timeline for BMP implementation will be prepared.

## **7.2 Reporting**

### **7.2.1 Discharge Monitoring Reports**

Discharge Monitoring Reports (DMRs) will be submitted to Ecology monthly. If there was no discharge during a given monitoring period the DMR will be submitted as required, reporting “No Discharge”. The DMR due date is fifteen (15) days following the end of each calendar month.

### **7.2.2 Notification of Noncompliance**

If any of the terms and conditions of the permit are not met, and it causes a threat to human health or the environment, the following steps will be taken in accordance with permit section S5.F:

1. Ecology will be notified within 24 hours of the failure to comply.
2. Immediate action will be taken to stop or correct the noncompliance issue and to correct the problem. If applicable, sampling and analysis of any noncompliance will be repeated immediately and the results submitted to Ecology within five (5) days of becoming aware of the violation.
3. A detailed written report describing the noncompliance will be submitted to Ecology within five (5) days, unless requested earlier by Ecology.
4. Anytime turbidity sampling indicated turbidity is 250 NTUs or greater, or water transparency is 6cm or less, ecology will be notified by phone within 24 hours of analysis.

## **Appendix A – Site Plans**

## **Appendix B – Construction BMPs**

Preserving Natural Vegetation (BMP C101)  
Buffer Zones (BMP C102)  
High Visibility Fence (BMP C103)  
Stabilized Construction Entrance (BMP C105)  
Wheel Wash (BMP C106)  
Construction Road/Parking Area Stabilization (BMP C107)  
Temporary and Permanent Seeding (BMP C120)  
Mulching (BMP C121)  
Nets and Blankets (BMP C122)  
Plastic Covering (BMP C123)  
Dust Control (BMP C140)  
Materials on Hand (BMP C150)  
Concrete Handling (BMP C151)  
Sawcutting and Surfacing Pollution Prevention (BMP C152)  
Interceptor Swales (BMP C200)  
Channel Lining (BMP C202)  
Water Bars (BMP C203)  
Pipe Slope Drains (BMP C204)  
Grass-Lined Channels (BMP C201)  
Check Dams (BMP C207)  
Outlet Protection (BMP C209)  
Strom Drain Inlet Protection (BMP C220)  
Gravel Filter Berm (BMP C232)  
Silt Fence (BMP C233)  
Sediment trap (BMP C240)  
Sediment pond (BMP C241)  
Construction Stormwater Chemical Treatment (BMP C250)  
Construction Stormwater Filtration (BMP C251)  
High pH Neutralization Using CO<sub>2</sub> (BMP C252)

## **BMP C101: Preserving Natural Vegetation**

**Purpose** The purpose of preserving natural vegetation is to reduce erosion wherever practicable. Limiting site disturbance is the single most effective method for reducing erosion. For example, conifers can hold up to about 50 percent of all rain that falls during a storm. Up to 20-30 percent of this rain may never reach the ground but is taken up by the tree or evaporates. Another benefit is that the rain held in the tree can be released slowly to the ground after the storm.

**Conditions of Use** Natural vegetation should be preserved on steep slopes, near perennial and intermittent watercourses or swales, and on building sites in wooded areas.

- As required by local governments.
- Phase construction to preserve natural vegetation on the project site for as long as possible during the construction period.

**Design and Installation Specifications** Natural vegetation can be preserved in natural clumps or as individual trees, shrubs and vines.

The preservation of individual plants is more difficult because heavy equipment is generally used to remove unwanted vegetation. The points to remember when attempting to save individual plants are:

- Is the plant worth saving? Consider the location, species, size, age, vigor, and the work involved. Local governments may also have ordinances to save natural vegetation and trees.
- Fence or clearly mark areas around trees that are to be saved. It is preferable to keep ground disturbance away from the trees at least as far out as the dripline.

Plants need protection from three kinds of injuries:

- *Construction Equipment* - This injury can be above or below the ground level. Damage results from scarring, cutting of roots, and compaction of the soil. Placing a fenced buffer zone around plants to be saved prior to construction can prevent construction equipment injuries.
- *Grade Changes* - Changing the natural ground level will alter grades, which affects the plant's ability to obtain the necessary air, water, and minerals. Minor fills usually do not cause problems although sensitivity between species does vary and should be checked. Trees can typically tolerate fill of 6 inches or less. For shrubs and other plants, the fill should be less.

When there are major changes in grade, it may become necessary to supply air to the roots of plants. This can be done by placing a layer of gravel and a tile system over the roots before the fill is made. A tile system protects a tree from a raised grade. The tile system should be

laid out on the original grade leading from a dry well around the tree trunk. The system should then be covered with small stones to allow air to circulate over the root area.

Lowering the natural ground level can seriously damage trees and shrubs. The highest percentage of the plant roots are in the upper 12 inches of the soil and cuts of only 2-3 inches can cause serious injury. To protect the roots it may be necessary to terrace the immediate area around the plants to be saved. If roots are exposed, construction of retaining walls may be needed to keep the soil in place. Plants can also be preserved by leaving them on an undisturbed, gently sloping mound. To increase the chances for survival, it is best to limit grade changes and other soil disturbances to areas outside the dripline of the plant.

- *Excavations* - Protect trees and other plants when excavating for drainfields, power, water, and sewer lines. Where possible, the trenches should be routed around trees and large shrubs. When this is not possible, it is best to tunnel under them. This can be done with hand tools or with power augers. If it is not possible to route the trench around plants to be saved, then the following should be observed:

Cut as few roots as possible. When you have to cut, cut clean. Paint cut root ends with a wood dressing like asphalt base paint if roots will be exposed for more than 24-hours.

Backfill the trench as soon as possible.

Tunnel beneath root systems as close to the center of the main trunk to preserve most of the important feeder roots.

Some problems that can be encountered with a few specific trees are:

- Maple, Dogwood, Red alder, Western hemlock, Western red cedar, and Douglas fir do not readily adjust to changes in environment and special care should be taken to protect these trees.
- The windthrow hazard of Pacific silver fir and madrona is high, while that of Western hemlock is moderate. The danger of windthrow increases where dense stands have been thinned. Other species (unless they are on shallow, wet soils less than 20 inches deep) have a low windthrow hazard.
- Cottonwoods, maples, and willows have water-seeking roots. These can cause trouble in sewer lines and infiltration fields. On the other hand, they thrive in high moisture conditions that other trees would not.
- Thinning operations in pure or mixed stands of Grand fir, Pacific silver fir, Noble fir, Sitka spruce, Western red cedar, Western hemlock, Pacific dogwood, and Red alder can cause serious disease problems. Disease can become established through damaged limbs, trunks, roots,

and freshly cut stumps. Diseased and weakened trees are also susceptible to insect attack.

***Maintenance Standards***

Inspect flagged and/or fenced areas regularly to make sure flagging or fencing has not been removed or damaged. If the flagging or fencing has been damaged or visibility reduced, it shall be repaired or replaced immediately and visibility restored.

- If tree roots have been exposed or injured, “prune” cleanly with an appropriate pruning saw or loppers directly above the damaged roots and recover with native soils. Treatment of sap flowing trees (fir, hemlock, pine, soft maples) is not advised as sap forms a natural healing barrier.

**BMP C102: Buffer Zones**

***Purpose***

Creation of an undisturbed area or strip of natural vegetation or an established suitable planting that will provide a living filter to reduce soil erosion and runoff velocities.

***Conditions of Use***

Natural buffer zones are used along streams, wetlands and other bodies of water that need protection from erosion and sedimentation. Vegetative buffer zones can be used to protect natural swales and can be incorporated into the natural landscaping of an area.

Critical-areas buffer zones should not be used as sediment treatment areas. These areas shall remain completely undisturbed. The local permitting authority may expand the buffer widths temporarily to allow the use of the expanded area for removal of sediment.

***Design and Installation Specifications***

- Preserving natural vegetation or plantings in clumps, blocks, or strips is generally the easiest and most successful method.
- Leave all unstable steep slopes in natural vegetation.
- Mark clearing limits and keep all equipment and construction debris out of the natural areas and buffer zones. Steel construction fencing is the most effective method in protecting sensitive areas and buffers. Alternatively, wire-backed silt fence on steel posts is marginally effective. Flagging alone is typically not effective.
- Keep all excavations outside the dripline of trees and shrubs.
- Do not push debris or extra soil into the buffer zone area because it will cause damage from burying and smothering.
- Vegetative buffer zones for streams, lakes or other waterways shall be established by the local permitting authority or other state or federal permits or approvals.

***Maintenance Standards***

Inspect the area frequently to make sure flagging remains in place and the area remains undisturbed. Replace all damaged flagging immediately.



## **BMP C103: High Visibility Fence**

### ***Purpose***

Fencing is intended to:

1. Restrict clearing to approved limits.
2. Prevent disturbance of sensitive areas, their buffers, and other areas required to be left undisturbed.
3. Limit construction traffic to designated construction entrances, exits, or internal roads.
4. Protect areas where marking with survey tape may not provide adequate protection.

### ***Conditions of Use***

To establish clearing limits plastic, fabric, or metal fence may be used:

- At the boundary of sensitive areas, their buffers, and other areas required to be left uncleared.
- As necessary to control vehicle access to and on the site.

### ***Design and Installation Specifications***

High visibility plastic fence shall be composed of a high-density polyethylene material and shall be at least four feet in height. Posts for the fencing shall be steel or wood and placed every 6 feet on center (maximum) or as needed to ensure rigidity. The fencing shall be fastened to the post every six inches with a polyethylene tie. On long continuous lengths of fencing, a tension wire or rope shall be used as a top stringer to prevent sagging between posts. The fence color shall be high visibility orange. The fence tensile strength shall be 360 lbs./ft. using the ASTM D4595 testing method.

If appropriate install fabric silt fence in accordance with [BMP C233](#) to act as high visibility fence. Silt fence shall be at least 3 feet high and must be highly visible to meet the requirements of this BMP.

Metal fences shall be designed and installed according to the manufacturer's specifications.

Metal fences shall be at least 3 feet high and must be highly visible.

Fences shall not be wired or stapled to trees.

### ***Maintenance Standards***

If the fence has been damaged or visibility reduced, it shall be repaired or replaced immediately and visibility restored.

## **BMP C105: Stabilized Construction Entrance / Exit**

**Purpose** Stabilized Construction entrances are established to reduce the amount of sediment transported onto paved roads by vehicles or equipment. This is done by constructing a stabilized pad of quarry spalls at entrances and exits for construction sites.

**Conditions of Use** Construction entrances shall be stabilized wherever traffic will be entering or leaving a construction site if paved roads or other paved areas are within 1,000 feet of the site.

For residential construction provide stabilized construction entrances for each residence, rather than only at the main subdivision entrance.

Stabilized surfaces shall be of sufficient length/width to provide vehicle access/parking, based on lot size/configuration.

On large commercial, highway, and road projects, the designer should include enough extra materials in the contract to allow for additional stabilized entrances not shown in the initial Construction SWPPP. It is difficult to determine exactly where access to these projects will take place; additional materials will enable the contractor to install them where needed.

### **Design and Installation Specifications**

See [Figure 4.1.1](#) for details. Note: the 100' minimum length of the entrance shall be reduced to the maximum practicable size when the size or configuration of the site does not allow the full length (100').

Construct stabilized construction entrances with a 12-inch thick pad of 4-inch to 8-inch quarry spalls, a 4-inch course of asphalt treated base (ATB), or use existing pavement. Do not use crushed concrete, cement, or calcium chloride for construction entrance stabilization because these products raise pH levels in stormwater and concrete discharge to surface waters of the State is prohibited.

A separation geotextile shall be placed under the spalls to prevent fine sediment from pumping up into the rock pad. The geotextile shall meet the following standards:

Grab Tensile Strength (ASTM D4751)	200 psi min.
Grab Tensile Elongation (ASTM D4632)	30% max.
Mullen Burst Strength (ASTM D3786-80a)	400 psi min.
AOS (ASTM D4751)	20-45 (U.S. standard sieve size)

- Consider early installation of the first lift of asphalt in areas that will be paved; this can be used as a stabilized entrance. Also consider the installation of excess concrete as a stabilized entrance. During large concrete pours, excess concrete is often available for this purpose.

- Fencing (see [BMP C103](#)) shall be installed as necessary to restrict traffic to the construction entrance.
- Whenever possible, the entrance shall be constructed on a firm, compacted subgrade. This can substantially increase the effectiveness of the pad and reduce the need for maintenance.
- Construction entrances should avoid crossing existing sidewalks and back of walk drains if at all possible. If a construction entrance must cross a sidewalk or back of walk drain, the full length of the sidewalk and back of walk drain must be covered and protected from sediment leaving the site.

***Maintenance Standards***

Quarry spalls shall be added if the pad is no longer in accordance with the specifications.

- If the entrance is not preventing sediment from being tracked onto pavement, then alternative measures to keep the streets free of sediment shall be used. This may include replacement/cleaning of the existing quarry spalls, street sweeping, an increase in the dimensions of the entrance, or the installation of a wheel wash.
- Any sediment that is tracked onto pavement shall be removed by shoveling or street sweeping. The sediment collected by sweeping shall be removed or stabilized on site. The pavement shall not be cleaned by washing down the street, except when high efficiency sweeping is ineffective and there is a threat to public safety. If it is necessary to wash the streets, the construction of a small sump to contain the wash water shall be considered. The sediment would then be washed into the sump where it can be controlled.
- Perform street sweeping by hand or with a high efficiency sweeper. Do not use a non-high efficiency mechanical sweeper because this creates dust and throws soils into storm systems or conveyance ditches.
- Any quarry spalls that are loosened from the pad, which end up on the roadway shall be removed immediately.
- If vehicles are entering or exiting the site at points other than the construction entrance(s), fencing (see [BMP C103](#)) shall be installed to control traffic.
- Upon project completion and site stabilization, all construction accesses intended as permanent access for maintenance shall be permanently stabilized.

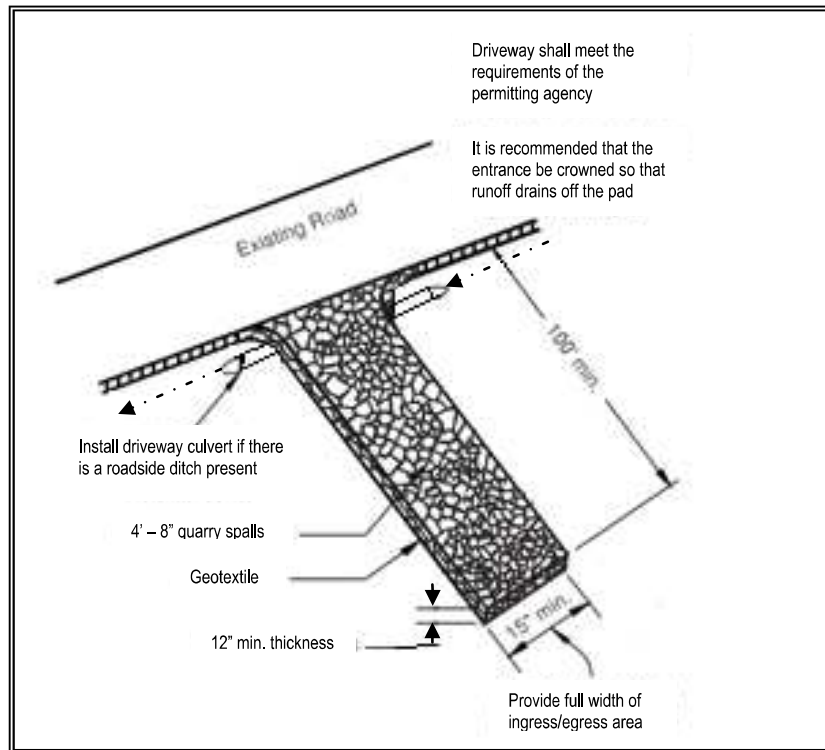

**Figure 4.1.1 – Stabilized Construction Entrance**

***Approved as Equivalent***

Ecology has approved products as able to meet the requirements of [BMP C105](#). The products did not pass through the Technology Assessment Protocol – Ecology (TAPE) process. Local jurisdictions may choose not to accept this product approved as equivalent, or may require additional testing prior to consideration for local use. The products are available for review on Ecology’s website at <http://www.ecy.wa.gov/programs/wq/stormwater/newtech/equivalent.html>

**BMP C106: Wheel Wash**

***Purpose***

Wheel washes reduce the amount of sediment transported onto paved roads by motor vehicles.

***Conditions of Use***

When a stabilized construction entrance (see [BMP C105](#)) is not preventing sediment from being tracked onto pavement.

- Wheel washing is generally an effective BMP when installed with careful attention to topography. For example, a wheel wash can be detrimental if installed at the top of a slope abutting a right-of-way where the water from the dripping truck can run unimpeded into the street.

- Pressure washing combined with an adequately sized and surfaced pad with direct drainage to a large 10-foot x 10-foot sump can be very effective.
- Discharge wheel wash or tire bath wastewater to a separate on-site treatment system that prevents discharge to surface water, such as closed-loop recirculation or upland land application, or to the sanitary sewer with local sewer district approval.
- Wheel wash or tire bath wastewater should not include wastewater from concrete washout areas.

***Design and  
Installation  
Specifications***

Suggested details are shown in [Figure 4.1.2](#). The Local Permitting Authority may allow other designs. A minimum of 6 inches of asphalt treated base (ATB) over crushed base material or 8 inches over a good subgrade is recommended to pave the wheel wash.

Use a low clearance truck to test the wheel wash before paving. Either a belly dump or lowboy will work well to test clearance.

Keep the water level from 12 to 14 inches deep to avoid damage to truck hubs and filling the truck tongues with water.

Midpoint spray nozzles are only needed in extremely muddy conditions.

Wheel wash systems should be designed with a small grade change, 6- to 1-inches for a 10-foot-wide pond, to allow sediment to flow to the low side of pond to help prevent re-suspension of sediment. A drainpipe with a 2- to 3-foot riser should be installed on the low side of the pond to allow for easy cleaning and refilling. Polymers may be used to promote coagulation and flocculation in a closed-loop system. Polyacrylamide (PAM) added to the wheel wash water at a rate of 0.25 - 0.5 pounds per 1,000 gallons of water increases effectiveness and reduces cleanup time. If PAM is already being used for dust or erosion control and is being applied by a water truck, the same truck can be used to change the wash water.

***Maintenance  
Standards***

The wheel wash should start out the day with fresh water.

The wash water should be changed a minimum of once per day. On large earthwork jobs where more than 10-20 trucks per hour are expected, the wash water will need to be changed more often.

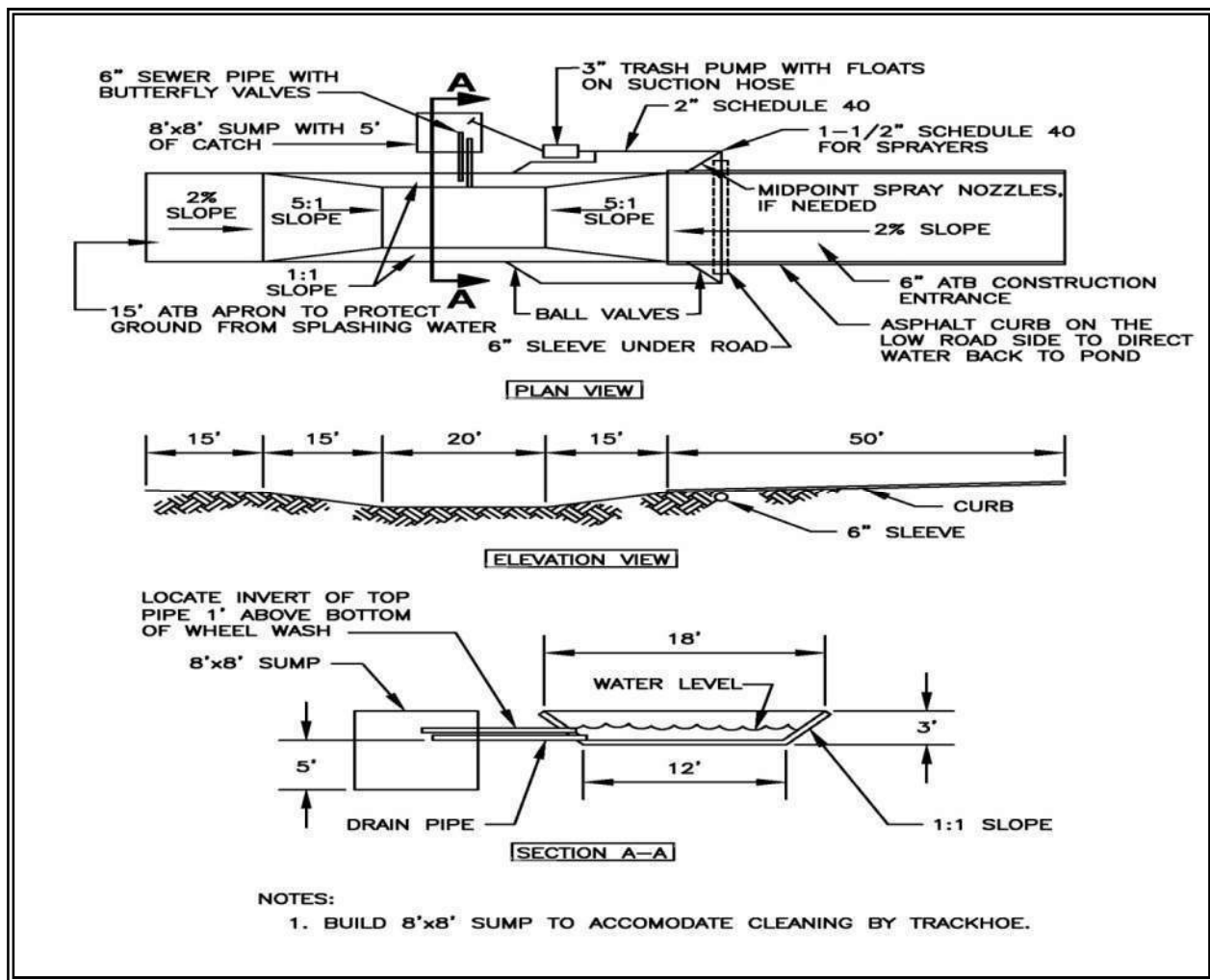

Figure 4.1.2 – Wheel Wash

Notes:

1. Asphalt construction entrance 6 in. asphalt treated base (ATB).
2. 3-inch trash pump with floats on the suction hose.
3. Midpoint spray nozzles, if needed.
4. 6-inch sewer pipe with butterfly valves. Bottom one is a drain. Locate top pipe's invert 1 foot above bottom of wheel wash.
5. 8 foot x 8 foot sump with 5 feet of catch. Build so the sump can be cleaned with a trackhoe.
6. Asphalt curb on the low road side to direct water back to pond.
7. 6-inch sleeve under road.
8. Ball valves.
9. 15 foot. ATB apron to protect ground from splashing water.

## **BMP C107: Construction Road/Parking Area Stabilization**

<i><b>Purpose</b></i>	Stabilizing subdivision roads, parking areas, and other on-site vehicle transportation routes immediately after grading reduces erosion caused by construction traffic or runoff.
<i><b>Conditions of Use</b></i>	Roads or parking areas shall be stabilized wherever they are constructed, whether permanent or temporary, for use by construction traffic. <ul style="list-style-type: none"><li>• High Visibility Fencing (see <a href="#">BMP C103</a>) shall be installed, if necessary, to limit the access of vehicles to only those roads and parking areas that are stabilized.</li></ul>
<i><b>Design and Installation Specifications</b></i>	<ul style="list-style-type: none"><li>• On areas that will receive asphalt as part of the project, install the first lift as soon as possible.</li><li>• A 6-inch depth of 2- to 4-inch crushed rock, gravel base, or crushed surfacing base course shall be applied immediately after grading or utility installation. A 4-inch course of asphalt treated base (ATB) may also be used, or the road/parking area may be paved. It may also be possible to use cement or calcium chloride for soil stabilization. If cement or cement kiln dust is used for roadbase stabilization, pH monitoring and BMPs (<a href="#">BMPs C252</a> and <a href="#">C253</a>) are necessary to evaluate and minimize the effects on stormwater. If the area will not be used for permanent roads, parking areas, or structures, a 6-inch depth of hog fuel may also be used, but this is likely to require more maintenance. Whenever possible, construction roads and parking areas shall be placed on a firm, compacted subgrade.</li><li>• Temporary road gradients shall not exceed 15 percent. Roadways shall be carefully graded to drain. Drainage ditches shall be provided on each side of the roadway in the case of a crowned section, or on one side in the case of a super-elevated section. Drainage ditches shall be directed to a sediment control BMP.</li><li>• Rather than relying on ditches, it may also be possible to grade the road so that runoff sheet-flows into a heavily vegetated area with a well-developed topsoil. Landscaped areas are not adequate. If this area has at least 50 feet of vegetation that water can flow through, then it is generally preferable to use the vegetation to treat runoff, rather than a sediment pond or trap. The 50 feet shall not include wetlands or their buffers. If runoff is allowed to sheetflow through adjacent vegetated areas, it is vital to design the roadways and parking areas so that no concentrated runoff is created.</li><li>• Storm drain inlets shall be protected to prevent sediment-laden water entering the storm drain system (see <a href="#">BMP C220</a>).</li></ul>
<i><b>Maintenance Standards</b></i>	Inspect stabilized areas regularly, especially after large storm events. Crushed rock, gravel base, etc. shall be added as required to maintain a

stable driving surface and to stabilize any areas that have eroded.

Following construction, these areas shall be restored to pre-construction condition or better to prevent future erosion.

Perform street cleaning at the end of each day or more often if necessary.

## **BMP C120: Temporary and Permanent Seeding**

### ***Purpose***

Seeding reduces erosion by stabilizing exposed soils. A well-established vegetative cover is one of the most effective methods of reducing erosion.

### ***Conditions of Use***

Use seeding throughout the project on disturbed areas that have reached final grade or that will remain unworked for more than 30 days.

The optimum seeding windows for western Washington are April 1 through June 30 and September 1 through October 1.

Between July 1 and August 30 seeding requires irrigation until 75 percent grass cover is established.

Between October 1 and March 30 seeding requires a cover of mulch with straw or an erosion control blanket until 75 percent grass cover is established.

Review all disturbed areas in late August to early September and complete all seeding by the end of September. Otherwise, vegetation will not establish itself enough to provide more than average protection.

- Mulch is required at all times for seeding because it protects seeds from heat, moisture loss, and transport due to runoff. Mulch can be applied on top of the seed or simultaneously by hydroseeding. See [BMP C121: Mulching](#) for specifications.
- Seed and mulch, all disturbed areas not otherwise vegetated at final site stabilization. Final stabilization means the completion of all soil disturbing activities at the site and the establishment of a permanent vegetative cover, or equivalent permanent stabilization measures (such as pavement, riprap, gabions or geotextiles) which will prevent erosion.

### ***Design and Installation Specifications***

Seed retention/detention ponds as required.

Install channels intended for vegetation before starting major earthwork and hydroseed with a Bonded Fiber Matrix. For vegetated channels that will have high flows, install erosion control blankets over hydroseed. Before allowing water to flow in vegetated channels, establish 75 percent vegetation cover. If vegetated channels cannot be established by seed before water flow; install sod in the channel bottom—over hydromulch and erosion control blankets.



- Confirm the installation of all required surface water control measures to prevent seed from washing away.
- Hydroseed applications shall include a minimum of 1,500 pounds per acre of mulch with 3 percent tackifier. See [BMP C121: Mulching](#) for specifications.
- Areas that will have seeding only and not landscaping may need compost or meal-based mulch included in the hydroseed in order to establish vegetation. Re-install native topsoil on the disturbed soil surface before application.
- When installing seed via hydroseeding operations, only about 1/3 of the seed actually ends up in contact with the soil surface. This reduces the ability to establish a good stand of grass quickly. To overcome this, consider increasing seed quantities by up to 50 percent.
- Enhance vegetation establishment by dividing the hydromulch operation into two phases:
  1. Phase 1- Install all seed and fertilizer with 25-30 percent mulch and tackifier onto soil in the first lift.
  2. Phase 2- Install the rest of the mulch and tackifier over the first lift.

Or, enhance vegetation by:

1. Installing the mulch, seed, fertilizer, and tackifier in one lift.
2. Spread or blow straw over the top of the hydromulch at a rate of 800-1000 pounds per acre.
3. Hold straw in place with a standard tackifier.

Both of these approaches will increase cost moderately but will greatly improve and enhance vegetative establishment. The increased cost may be offset by the reduced need for:

- Irrigation.
- Reapplication of mulch.
- Repair of failed slope surfaces.

This technique works with standard hydromulch (1,500 pounds per acre minimum) and BFM/MBFMs (3,000 pounds per acre minimum).

- Seed may be installed by hand if:
  - Temporary and covered by straw, mulch, or topsoil.
  - Permanent in small areas (usually less than 1 acre) and covered with mulch, topsoil, or erosion blankets.
- The seed mixes listed in the tables below include recommended mixes for both temporary and permanent seeding.

- Apply these mixes, with the exception of the wetland mix, at a rate of 120 pounds per acre. This rate can be reduced if soil amendments or slow-release fertilizers are used.
- Consult the local suppliers or the local conservation district for their recommendations because the appropriate mix depends on a variety of factors, including location, exposure, soil type, slope, and expected foot traffic. Alternative seed mixes approved by the local authority may be used.
- Other mixes may be appropriate, depending on the soil type and hydrology of the area.
- [Table 4.1.2](#) lists the standard mix for areas requiring a temporary vegetative cover.

<b>Table 4.1.2 Temporary Erosion Control Seed Mix</b>			
	% Weight	% Purity	% Germination
Chewings or annual blue grass <i>Festuca rubra var. commutata</i> or <i>Poa anna</i>	40	98	90
Perennial rye - <i>Lolium perenne</i>	50	98	90
Redtop or colonial bentgrass <i>Agrostis alba</i> or <i>Agrostis tenuis</i>	5	92	85
White dutch clover <i>Trifolium repens</i>	5	98	90

- [Table 4.1.3](#) lists a recommended mix for landscaping seed.

<b>Table 4.1.3 Landscaping Seed Mix</b>			
	% Weight	% Purity	% Germination
Perennial rye blend <i>Lolium perenne</i>	70	98	90
Chewings and red fescue blend <i>Festuca rubra var. commutata</i> or <i>Festuca rubra</i>	30	98	90

- [Table 4.1.4](#) lists a turf seed mix for dry situations where there is no need for watering. This mix requires very little maintenance.

<b>Table 4.1.4 Low-Growing Turf Seed Mix</b>			
	% Weight	% Purity	% Germination
Dwarf tall fescue (several varieties) <i>Festuca arundinacea</i> var.	45	98	90
Dwarf perennial rye (Barclay) <i>Lolium perenne</i> var. <i>barclay</i>	30	98	90
Red fescue <i>Festuca rubra</i>	20	98	90
Colonial bentgrass <i>Agrostis tenuis</i>	5	98	90

- [Table 4.1.5](#) lists a mix for bioswales and other intermittently wet areas.

<b>Table 4.1.5 Bioswale Seed Mix*</b>			
	% Weight	% Purity	% Germination
Tall or meadow fescue <i>Festuca arundinacea</i> or <i>Festuca elatior</i>	75-80	98	90
Seaside/Creeping bentgrass <i>Agrostis palustris</i>	10-15	92	85
Redtop bentgrass <i>Agrostis alba</i> or <i>Agrostis gigantea</i>	5-10	90	80

\* Modified Briargreen, Inc. Hydroseeding Guide Wetlands Seed Mix

- [Table 4.1.6](#) lists a low-growing, relatively non-invasive seed mix appropriate for very wet areas that are not regulated wetlands. Apply this mixture at a rate of 60 pounds per acre. Consult Hydraulic Permit Authority (HPA) for seed mixes if applicable.

<b>Table 4.1.6 Wet Area Seed Mix*</b>			
	<b>% Weight</b>	<b>% Purity</b>	<b>% Germination</b>
Tall or meadow fescue <i>Festuca arundinacea</i> or <i>Festuca elatior</i>	60-70	98	90
Seaside/Creeping bentgrass <i>Agrostis palustris</i>	10-15	98	85
Meadow foxtail <i>Alepecurus pratensis</i>	10-15	90	80
Alsike clover <i>Trifolium hybridum</i>	1-6	98	90
Redtop bentgrass <i>Agrostis alba</i>	1-6	92	85

\* Modified Briargreen, Inc. Hydroseeding Guide Wetlands Seed Mix

- Table 4.1.7 lists a recommended meadow seed mix for infrequently maintained areas or non-maintained areas where colonization by native plants is desirable. Likely applications include rural road and utility right-of-way. Seeding should take place in September or very early October in order to obtain adequate establishment prior to the winter months. Consider the appropriateness of clover, a fairly invasive species, in the mix. Amending the soil can reduce the need for clover.

<b>Table 4.1.7 Meadow Seed Mix</b>			
	<b>% Weight</b>	<b>% Purity</b>	<b>% Germination</b>
Redtop or Oregon bentgrass <i>Agrostis alba</i> or <i>Agrostis oregonensis</i>	20	92	85
Red fescue <i>Festuca rubra</i>	70	98	90
White dutch clover <i>Trifolium repens</i>	10	98	90

- **Roughening and Rototilling:**
  - The seedbed should be firm and rough. Roughen all soil no matter what the slope. Track walk slopes before seeding if engineering purposes require compaction. Backblading or smoothing of slopes greater than 4H:1V is not allowed if they are to be seeded.
  - Restoration-based landscape practices require deeper incorporation than that provided by a simple single-pass rototilling treatment. Wherever practical, initially rip the subgrade to improve long-term permeability, infiltration, and water inflow qualities. At a minimum, permanent areas shall use soil amendments to achieve organic matter and permeability performance defined in engineered soil/landscape systems. For systems that are deeper than 8 inches complete the rototilling process in multiple lifts, or prepare the engineered soil system per specifications and place to achieve the specified depth.
- **Fertilizers:**
  - Conducting soil tests to determine the exact type and quantity of fertilizer is recommended. This will prevent the over-application of fertilizer.
  - Organic matter is the most appropriate form of fertilizer because it provides nutrients (including nitrogen, phosphorus, and potassium) in the least water-soluble form.
  - In general, use 10-4-6 N-P-K (nitrogen-phosphorus-potassium) fertilizer at a rate of 90 pounds per acre. Always use slow-release fertilizers because they are more efficient and have fewer environmental impacts. Do not add fertilizer to the hydromulch machine, or agitate, more than 20 minutes before use. Too much agitation destroys the slow-release coating.
  - There are numerous products available that take the place of chemical fertilizers. These include several with seaweed extracts that are beneficial to soil microbes and organisms. If 100 percent cottonseed meal is used as the mulch in hydroseed, chemical fertilizer may not be necessary. Cottonseed meal provides a good source of long-term, slow-release, available nitrogen.
- **Bonded Fiber Matrix and Mechanically Bonded Fiber Matrix:**
  - On steep slopes use Bonded Fiber Matrix (BFM) or Mechanically Bonded Fiber Matrix (MBFM) products. Apply BFM/MBFM products at a minimum rate of 3,000 pounds per acre of mulch with approximately 10 percent tackifier. Achieve a minimum of 95 percent soil coverage during application. Numerous products are available commercially. Installed products per manufacturer's instructions. Most products require 24-36 hours to cure before rainfall and cannot be installed on wet or saturated soils.

Generally, products come in 40-50 pound bags and include all necessary ingredients except for seed and fertilizer.

- BFM and MBFMs provide good alternatives to blankets in most areas requiring vegetation establishment. Advantages over blankets include:
  - BFM and MBFMs do not require surface preparation.
  - Helicopters can assist in installing BFM and MBFMs in remote areas.
  - On slopes steeper than 2.5H:1V, blanket installers may require ropes and harnesses for safety.
  - Installing BFM and MBFMs can save at least \$1,000 per acre compared to blankets.

***Maintenance Standards***

Reseed any seeded areas that fail to establish at least 80 percent cover (100 percent cover for areas that receive sheet or concentrated flows). If reseeding is ineffective, use an alternate method such as sodding, mulching, or nets/blankets. If winter weather prevents adequate grass growth, this time limit may be relaxed at the discretion of the local authority when sensitive areas would otherwise be protected.

- Reseed and protect by mulch any areas that experience erosion after achieving adequate cover. Reseed and protect by mulch any eroded area.
- Supply seeded areas with adequate moisture, but do not water to the extent that it causes runoff.

***Approved as Equivalent***

Ecology has approved products as able to meet the requirements of [BMP C120](#). The products did not pass through the Technology Assessment Protocol – Ecology (TAPE) process. Local jurisdictions may choose not to accept this product approved as equivalent, or may require additional testing prior to consideration for local use. The products are available for review on Ecology’s website at <http://www.ecy.wa.gov/programs/wq/stormwater/newtech/equivalent.html>

**BMP C121: Mulching**

***Purpose***

Mulching soils provides immediate temporary protection from erosion. Mulch also enhances plant establishment by conserving moisture, holding fertilizer, seed, and topsoil in place, and moderating soil temperatures. There is an enormous variety of mulches that can be used. This section discusses only the most common types of mulch.

***Conditions of Use***

As a temporary cover measure, mulch should be used:

- For less than 30 days on disturbed areas that require cover.
- At all times for seeded areas, especially during the wet season and

during the hot summer months.

- During the wet season on slopes steeper than 3H:1V with more than 10 feet of vertical relief.

Mulch may be applied at any time of the year and must be refreshed periodically.

- For seeded areas mulch may be made up of 100 percent: cottonseed meal; fibers made of wood, recycled cellulose, hemp, kenaf; compost; or blends of these. Tackifier shall be plant-based, such as guar or alpha plantago, or chemical-based such as polyacrylamide or polymers. Any mulch or tackifier product used shall be installed per manufacturer's instructions. Generally, mulches come in 40-50 pound bags. Seed and fertilizer are added at time of application.

***Design and  
Installation  
Specifications***

For mulch materials, application rates, and specifications, see [Table 4.1.8](#). Always use a 2-inch minimum mulch thickness; increase the thickness until the ground is 95% covered (i.e. not visible under the mulch layer). Note: Thickness may be increased for disturbed areas in or near sensitive areas or other areas highly susceptible to erosion.

Mulch used within the ordinary high-water mark of surface waters should be selected to minimize potential flotation of organic matter. Composted organic materials have higher specific gravities (densities) than straw, wood, or chipped material. Consult Hydraulic Permit Authority (HPA) for mulch mixes if applicable.

***Maintenance  
Standards***

- The thickness of the cover must be maintained.
- Any areas that experience erosion shall be remulched and/or protected with a net or blanket. If the erosion problem is drainage related, then the problem shall be fixed and the eroded area remulched.

**Table 4.1.8  
Mulch Standards and Guidelines**

<b>Mulch Material</b>	<b>Quality Standards</b>	<b>Application Rates</b>	<b>Remarks</b>
Straw	Air-dried; free from undesirable seed and coarse material.	2"-3" thick; 5 bales per 1,000 sf or 2-3 tons per acre	Cost-effective protection when applied with adequate thickness. Hand-application generally requires greater thickness than blown straw. The thickness of straw may be reduced by half when used in conjunction with seeding. In windy areas straw must be held in place by crimping, using a tackifier, or covering with netting. Blown straw always has to be held in place with a tackifier as even light winds will blow it away. Straw, however, has several deficiencies that should be considered when selecting mulch materials. It often introduces and/or encourages the propagation of weed species and it has no significant long-term benefits. It should also not be used within the ordinary high-water elevation of surface waters (due to flotation).
Hydromulch	No growth inhibiting factors.	Approx. 25-30 lbs per 1,000 sf or 1,500 - 2,000 lbs per acre	Shall be applied with hydromulcher. Shall not be used without seed and tackifier unless the application rate is at least doubled. Fibers longer than about ¾-1 inch clog hydromulch equipment. Fibers should be kept to less than ¾ inch.
Composted Mulch and Compost	No visible water or dust during handling. Must be produced in accordance with <a href="#">WAC 173-350</a> , Solid Waste Handling Standards.	2" thick min.; approx. 100 tons per acre (approx. 800 lbs per yard)	More effective control can be obtained by increasing thickness to 3". Excellent mulch for protecting final grades until landscaping because it can be directly seeded or tilled into soil as an amendment. Composted mulch has a coarser size gradation than compost. It is more stable and practical to use in wet areas and during rainy weather conditions. Do not use composted mulch near wetlands or near phosphorous impaired water bodies.
Chipped Site Vegetation	Average size shall be several inches. Gradations from fines to 6 inches in length for texture, variation, and interlocking properties.	2" thick min.;	This is a cost-effective way to dispose of debris from clearing and grubbing, and it eliminates the problems associated with burning. Generally, it should not be used on slopes above approx. 10% because of its tendency to be transported by runoff. It is not recommended within 200 feet of surface waters. If seeding is expected shortly after mulch, the decomposition of the chipped vegetation may tie up nutrients important to grass establishment.
Wood-based Mulch or Wood Straw	No visible water or dust during handling. Must be purchased from a supplier with a Solid Waste Handling Permit or one exempt from solid waste regulations.	2" thick min.; approx. 100 tons per acre (approx. 800 lbs. per cubic yard)	This material is often called "hog or hogged fuel." The use of mulch ultimately improves the organic matter in the soil. Special caution is advised regarding the source and composition of wood-based mulches. Its preparation typically does not provide any weed seed control, so evidence of residual vegetation in its composition or known inclusion of weed plants or seeds should be monitored and prevented (or minimized).
Wood Strand Mulch	A blend of loose, long, thin wood pieces derived from native conifer or deciduous trees with high length-to-width ratio.	2" thick min.	Cost-effective protection when applied with adequate thickness. A minimum of 95-percent of the wood strand shall have lengths between 2 and 10-inches, with a width and thickness between 1/16 and ¾-inches. The mulch shall not contain resin, tannin, or other compounds in quantities that would be detrimental to plant life. Sawdust or wood shavings shall not be used as mulch. (WSDOT specification (9-14.4(4)))



## **BMP C122: Nets and Blankets**

### *Purpose*

Erosion control nets and blankets are intended to prevent erosion and hold seed and mulch in place on steep slopes and in channels so that vegetation can become well established. In addition, some nets and blankets can be used to permanently reinforce turf to protect drainage ways during high flows. Nets (commonly called matting) are strands of material woven into an open, but high-tensile strength net (for example, coconut fiber matting). Blankets are strands of material that are not tightly woven, but instead form a layer of interlocking fibers, typically held together by a biodegradable or photodegradable netting (for example, excelsior or straw blankets). They generally have lower tensile strength than nets, but cover the ground more completely. Coir (coconut fiber) fabric comes as both nets and blankets.

### *Conditions of Use*

Erosion control nets and blankets should be used:

- To aid permanent vegetated stabilization of slopes 2H:1V or greater and with more than 10 feet of vertical relief.
- For drainage ditches and swales (highly recommended). The application of appropriate netting or blanket to drainage ditches and swales can protect bare soil from channelized runoff while vegetation is established. Nets and blankets also can capture a great deal of sediment due to their open, porous structure. Nets and blankets can be used to permanently stabilize channels and may provide a cost-effective, environmentally preferable alternative to riprap. 100 percent synthetic blankets manufactured for use in ditches may be easily reused as temporary ditch liners.

Disadvantages of blankets include:

- Surface preparation required.
- On slopes steeper than 2.5H:1V, blanket installers may need to be roped and harnessed for safety.
- They cost at least \$4,000-6,000 per acre installed.

Advantages of blankets include:

- Installation without mobilizing special equipment.
- Installation by anyone with minimal training
- Installation in stages or phases as the project progresses.
- Installers can hand place seed and fertilizer as they progress down the slope.
- Installation in any weather.
- There are numerous types of blankets that can be designed with various parameters in mind. Those parameters include: fiber blend, mesh strength, longevity, biodegradability, cost, and availability.

***Design and  
Installation  
Specifications***

- See [Figure 4.1.3](#) and [Figure 4.1.4](#) for typical orientation and installation of blankets used in channels and as slope protection. Note: these are typical only; all blankets must be installed per manufacturer's installation instructions.
- Installation is critical to the effectiveness of these products. If good ground contact is not achieved, runoff can concentrate under the product, resulting in significant erosion.
- Installation of Blankets on Slopes:
  1. Complete final grade and track walk up and down the slope.
  2. Install hydromulch with seed and fertilizer.
  3. Dig a small trench, approximately 12 inches wide by 6 inches deep along the top of the slope.
  4. Install the leading edge of the blanket into the small trench and staple approximately every 18 inches. NOTE: Staples are metal, "U"-shaped, and a minimum of 6 inches long. Longer staples are used in sandy soils. Biodegradable stakes are also available.
  5. Roll the blanket slowly down the slope as installer walks backwards. NOTE: The blanket rests against the installer's legs. Staples are installed as the blanket is unrolled. It is critical that the proper staple pattern is used for the blanket being installed. The blanket is not to be allowed to roll down the slope on its own as this stretches the blanket making it impossible to maintain soil contact. In addition, no one is allowed to walk on the blanket after it is in place.
  6. If the blanket is not long enough to cover the entire slope length, the trailing edge of the upper blanket should overlap the leading edge of the lower blanket and be stapled. On steeper slopes, this overlap should be installed in a small trench, stapled, and covered with soil.
- With the variety of products available, it is impossible to cover all the details of appropriate use and installation. Therefore, it is critical that the design engineer consult the manufacturer's information and that a site visit takes place in order to ensure that the product specified is appropriate. Information is also available at the following web sites:
  1. WSDOT (Section 3.2.4):  
<http://www.wsdot.wa.gov/NR/rdonlyres/3B41E087-FA86-4717-932D-D7A8556CCD57/0/ErosionTrainingManual.pdf>
  2. Texas Transportation Institute:  
[http://www.txdot.gov/business/doing\\_business/product\\_evaluation/erosion\\_control.htm](http://www.txdot.gov/business/doing_business/product_evaluation/erosion_control.htm)

- Use jute matting in conjunction with mulch ([BMP C121](#)). Excelsior, woven straw blankets and coir (coconut fiber) blankets may be installed without mulch. There are many other types of erosion control nets and blankets on the market that may be appropriate in certain circumstances.
  - In general, most nets (e.g., jute matting) require mulch in order to prevent erosion because they have a fairly open structure. Blankets typically do not require mulch because they usually provide complete protection of the surface.
  - Extremely steep, unstable, wet, or rocky slopes are often appropriate candidates for use of synthetic blankets, as are riverbanks, beaches and other high-energy environments. If synthetic blankets are used, the soil should be hydromulched first.
  - 100-percent biodegradable blankets are available for use in sensitive areas. These organic blankets are usually held together with a paper or fiber mesh and stitching which may last up to a year.
  - Most netting used with blankets is photodegradable, meaning they break down under sunlight (not UV stabilized). However, this process can take months or years even under bright sun. Once vegetation is established, sunlight does not reach the mesh. It is not uncommon to find non-degraded netting still in place several years after installation. This can be a problem if maintenance requires the use of mowers or ditch cleaning equipment. In addition, birds and small animals can become trapped in the netting.
- Maintenance Standards***
- Maintain good contact with the ground. Erosion must not occur beneath the net or blanket.
  - Repair and staple any areas of the net or blanket that are damaged or not in close contact with the ground.
  - Fix and protect eroded areas if erosion occurs due to poorly controlled drainage.

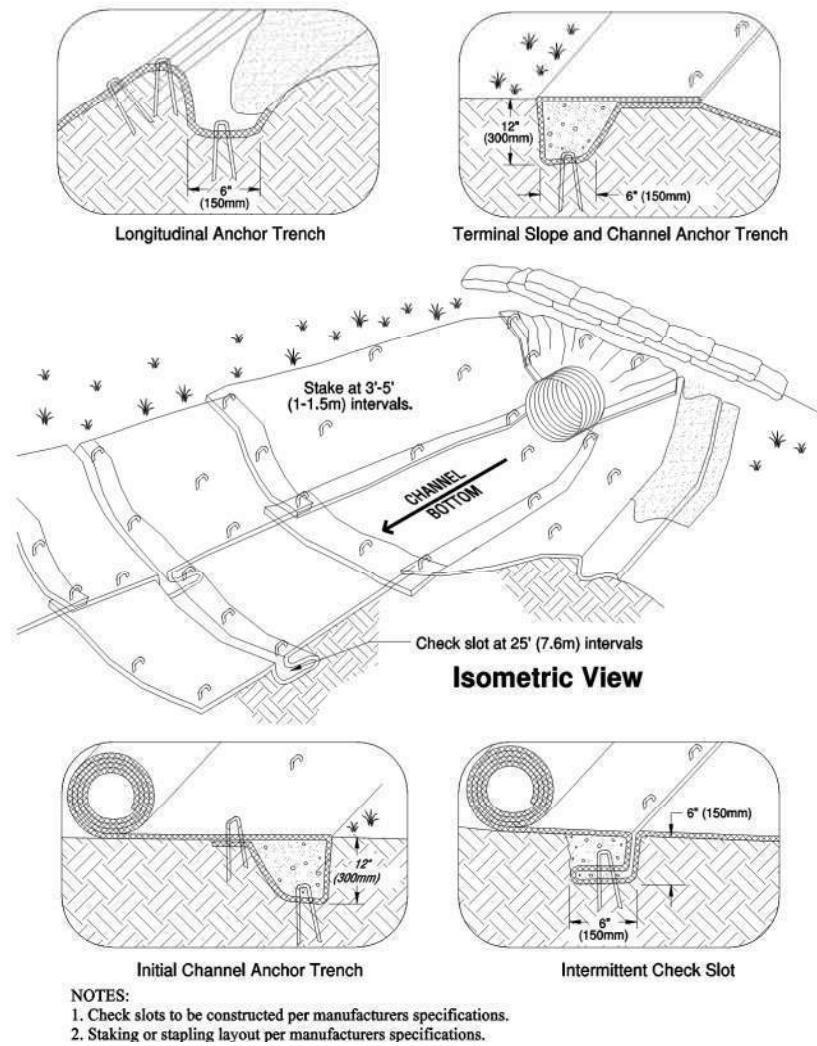

**Figure 4.1.3 – Channel Installation**

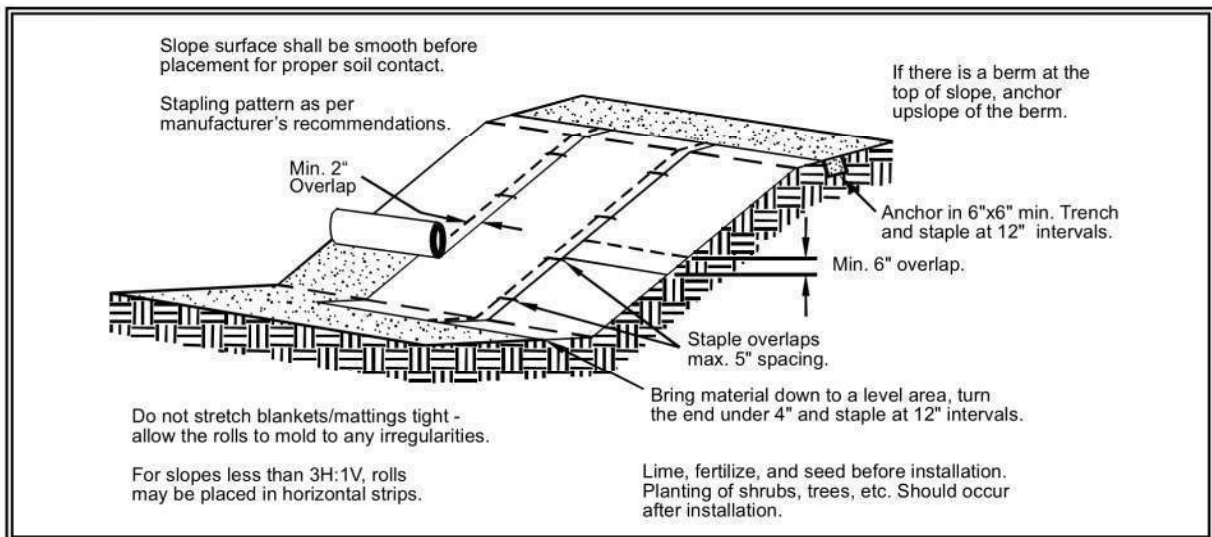

**Figure 4.1.4 – Slope Installation**



## **BMP C123: Plastic Covering**

### ***Purpose***

Plastic covering provides immediate, short-term erosion protection to slopes and disturbed areas.

### ***Conditions of Use***

Plastic covering may be used on disturbed areas that require cover measures for less than 30 days, except as stated below.

- Plastic is particularly useful for protecting cut and fill slopes and stockpiles. Note: The relatively rapid breakdown of most polyethylene sheeting makes it unsuitable for long-term (greater than six months) applications.
- Due to rapid runoff caused by plastic covering, do not use this method upslope of areas that might be adversely impacted by concentrated runoff. Such areas include steep and/or unstable slopes.
- Plastic sheeting may result in increased runoff volumes and velocities, requiring additional on-site measures to counteract the increases. Creating a trough with wattles or other material can convey clean water away from these areas.
- To prevent undercutting, trench and backfill rolled plastic covering products.
- While plastic is inexpensive to purchase, the added cost of installation, maintenance, removal, and disposal make this an expensive material, up to \$1.50-2.00 per square yard.
- Whenever plastic is used to protect slopes install water collection measures at the base of the slope. These measures include plastic-covered berms, channels, and pipes used to convey clean rainwater away from bare soil and disturbed areas. Do not mix clean runoff from a plastic covered slope with dirty runoff from a project.
- Other uses for plastic include:
  1. Temporary ditch liner.
  2. Pond liner in temporary sediment pond.
  3. Liner for bermed temporary fuel storage area if plastic is not reactive to the type of fuel being stored.
  4. Emergency slope protection during heavy rains.
  5. Temporary drainpipe (“elephant trunk”) used to direct water.
- Plastic slope cover must be installed as follows:
  1. Run plastic up and down slope, not across slope.
  2. Plastic may be installed perpendicular to a slope if the slope length is less than 10 feet.
  3. Minimum of 8-inch overlap at seams.

### ***Design and Installation Specifications***

4. On long or wide slopes, or slopes subject to wind, tape all seams.
  5. Place plastic into a small (12-inch wide by 6-inch deep) slot trench at the top of the slope and backfill with soil to keep water from flowing underneath.
  6. Place sand filled burlap or geotextile bags every 3 to 6 feet along seams and tie them together with twine to hold them in place.
  7. Inspect plastic for rips, tears, and open seams regularly and repair immediately. This prevents high velocity runoff from contacting bare soil which causes extreme erosion.
  8. Sandbags may be lowered into place tied to ropes. However, all sandbags must be staked in place.
- Plastic sheeting shall have a minimum thickness of 0.06 millimeters.
  - If erosion at the toe of a slope is likely, a gravel berm, riprap, or other suitable protection shall be installed at the toe of the slope in order to reduce the velocity of runoff.
  - Torn sheets must be replaced and open seams repaired.
  - Completely remove and replace the plastic if it begins to deteriorate due to ultraviolet radiation.
  - Completely remove plastic when no longer needed.
  - Dispose of old tires used to weight down plastic sheeting appropriately.

***Maintenance Standards***

***Approved as Equivalent***

Ecology has approved products as able to meet the requirements of [BMP C123](#). The products did not pass through the Technology Assessment Protocol – Ecology (TAPE) process. Local jurisdictions may choose not to accept this product approved as equivalent, or may require additional testing prior to consideration for local use. The products are available for review on Ecology’s website at <http://www.ecy.wa.gov/programs/wq/stormwater/newtech/equivalent.html>

**BMP C124: Sodding**

***Purpose***

The purpose of sodding is to establish permanent turf for immediate erosion protection and to stabilize drainage ways where concentrated overland flow will occur.

***Conditions of Use***

Sodding may be used in the following areas:

- Disturbed areas that require short-term or long-term cover.
- Disturbed areas that require immediate vegetative cover.
- All waterways that require vegetative lining. Waterways may also be seeded rather than sodded, and protected with a net or blanket.

## **BMP C140: Dust Control**

### ***Purpose***

Dust control prevents wind transport of dust from disturbed soil surfaces onto roadways, drainage ways, and surface waters.

### ***Conditions of Use***

- In areas (including roadways) subject to surface and air movement of dust where on-site and off-site impacts to roadways, drainage ways, or surface waters are likely.

### ***Design and Installation Specifications***

- Vegetate or mulch areas that will not receive vehicle traffic. In areas where planting, mulching, or paving is impractical, apply gravel or landscaping rock.
- Limit dust generation by clearing only those areas where immediate activity will take place, leaving the remaining area(s) in the original condition. Maintain the original ground cover as long as practical.
- Construct natural or artificial windbreaks or windscreens. These may be designed as enclosures for small dust sources.
- Sprinkle the site with water until surface is wet. Repeat as needed. To prevent carryout of mud onto street, refer to Stabilized Construction Entrance ([BMP C105](#)).
- Irrigation water can be used for dust control. Irrigation systems should be installed as a first step on sites where dust control is a concern.
- Spray exposed soil areas with a dust palliative, following the manufacturer's instructions and cautions regarding handling and application. Used oil is prohibited from use as a dust suppressant. Local governments may approve other dust palliatives such as calcium chloride or PAM.
- PAM ([BMP C126](#)) added to water at a rate of 0.5 lbs. per 1,000 gallons of water per acre and applied from a water truck is more effective than water alone. This is due to increased infiltration of water into the soil and reduced evaporation. In addition, small soil particles are bonded together and are not as easily transported by wind. Adding PAM may actually reduce the quantity of water needed for dust control. Use of PAM could be a cost-effective dust control method.

Techniques that can be used for unpaved roads and lots include:

- Lower speed limits. High vehicle speed increases the amount of dust stirred up from unpaved roads and lots.
- Upgrade the road surface strength by improving particle size, shape, and mineral types that make up the surface and base materials.
- Add surface gravel to reduce the source of dust emission. Limit the amount of fine particles (those smaller than .075 mm) to 10 to 20 percent.

- Use geotextile fabrics to increase the strength of new roads or roads undergoing reconstruction.
- Encourage the use of alternate, paved routes, if available.
- Restrict use of paved roadways by tracked vehicles and heavy trucks to prevent damage to road surface and base.
- Apply chemical dust suppressants using the admix method, blending the product with the top few inches of surface material. Suppressants may also be applied as surface treatments.
- Pave unpaved permanent roads and other trafficked areas.
- Use vacuum street sweepers.
- Remove mud and other dirt promptly so it does not dry and then turn into dust.
- Limit dust-causing work on windy days.
- Contact your local Air Pollution Control Authority for guidance and training on other dust control measures. Compliance with the local Air Pollution Control Authority constitutes compliance with this BMP.

***Maintenance Standards***

Respray area as necessary to keep dust to a minimum.

**BMP C150: Materials on Hand**

***Purpose***

Keep quantities of erosion prevention and sediment control materials on the project site at all times to be used for regular maintenance and emergency situations such as unexpected heavy summer rains. Having these materials on-site reduces the time needed to implement BMPs when inspections indicate that existing BMPs are not meeting the Construction SWPPP requirements. In addition, contractors can save money by buying some materials in bulk and storing them at their office or yard.

***Conditions of Use***

- Construction projects of any size or type can benefit from having materials on hand. A small commercial development project could have a roll of plastic and some gravel available for immediate protection of bare soil and temporary berm construction. A large earthwork project, such as highway construction, might have several tons of straw, several rolls of plastic, flexible pipe, sandbags, geotextile fabric and steel “T” posts.
- Materials are stockpiled and readily available before any site clearing, grubbing, or earthwork begins. A large contractor or developer could keep a stockpile of materials that are available for use on several projects.
- If storage space at the project site is at a premium, the contractor could maintain the materials at their office or yard. The office or yard must be less than an hour from the project site.



***Design and Installation Specifications***

Depending on project type, size, complexity, and length, materials and quantities will vary. A good minimum list of items that will cover numerous situations includes:

<b>Material</b>
Clear Plastic, 6 mil
Drainpipe, 6 or 8 inch diameter
Sandbags, filled
Straw Bales for mulching,
Quarry Spalls
Washed Gravel
Geotextile Fabric
Catch Basin Inserts
Steel "T" Posts
Silt fence material
Straw Wattles

***Maintenance Standards***

- All materials with the exception of the quarry spalls, steel "T" posts, and gravel should be kept covered and out of both sun and rain.
- Re-stock materials used as needed.

**BMP C151: Concrete Handling**

***Purpose***

Concrete work can generate process water and slurry that contain fine particles and high pH, both of which can violate water quality standards in the receiving water. Concrete spillage or concrete discharge to surface waters of the State is prohibited. Use this BMP to minimize and eliminate concrete, concrete process water, and concrete slurry from entering waters of the state.

***Conditions of Use***

Any time concrete is used, utilize these management practices. Concrete construction projects include, but are not limited to, the following:

- Curbs
- Sidewalks
- Roads
- Bridges
- Foundations
- Floors
- Runways

***Design and Installation***

- Wash out concrete truck chutes, pumps, and internals into formed areas only. Assure that washout of concrete trucks is performed off-

## ***Specifications***

site or in designated concrete washout areas. Do not wash out concrete trucks onto the ground, or into storm drains, open ditches, streets, or streams. Refer to [BMP C154](#) for information on concrete washout areas.

- Return unused concrete remaining in the truck and pump to the originating batch plant for recycling. Do not dump excess concrete on site, except in designated concrete washout areas.
- Wash off hand tools including, but not limited to, screeds, shovels, rakes, floats, and trowels into formed areas only.
- Wash equipment difficult to move, such as concrete pavers in areas that do not directly drain to natural or constructed stormwater conveyances.
- Do not allow washdown from areas, such as concrete aggregate driveways, to drain directly to natural or constructed stormwater conveyances.
- Contain washwater and leftover product in a lined container when no formed areas are available,. Dispose of contained concrete in a manner that does not violate ground water or surface water quality standards.
- Always use forms or solid barriers for concrete pours, such as pilings, within 15-feet of surface waters.
- Refer to [BMPs C252](#) and [C253](#) for pH adjustment requirements.
- Refer to the Construction Stormwater General Permit for pH monitoring requirements if the project involves one of the following activities:
  - Significant concrete work (greater than 1,000 cubic yards poured concrete or recycled concrete used over the life of a project).
  - The use of engineered soils amended with (but not limited to) Portland cement-treated base, cement kiln dust or fly ash.
  - Discharging stormwater to segments of water bodies on the 303(d) list (Category 5) for high pH.

## ***Maintenance Standards***

Check containers for holes in the liner daily during concrete pours and repair the same day.

## **BMP C152: Sawcutting and Surfacing Pollution Prevention**

***Purpose*** Sawcutting and surfacing operations generate slurry and process water that contains fine particles and high pH (concrete cutting), both of which can violate the water quality standards in the receiving water. Concrete spillage or concrete discharge to surface waters of the State is prohibited. Use this BMP to minimize and eliminate process water and slurry created through sawcutting or surfacing from entering waters of the State.

***Conditions of Use*** Utilize these management practices anytime sawcutting or surfacing operations take place. Sawcutting and surfacing operations include, but are not limited to, the following:

- Sawing
- Coring
- Grinding
- Roughening
- Hydro-demolition
- Bridge and road surfacing
- Vacuum slurry and cuttings during cutting and surfacing operations.
- Slurry and cuttings shall not remain on permanent concrete or asphalt pavement overnight.
- Slurry and cuttings shall not drain to any natural or constructed drainage conveyance including stormwater systems. This may require temporarily blocking catch basins.
- Dispose of collected slurry and cuttings in a manner that does not violate ground water or surface water quality standards.
- Do not allow process water generated during hydro-demolition, surface roughening or similar operations to drain to any natural or constructed drainage conveyance including stormwater systems. Dispose process water in a manner that does not violate ground water or surface water quality standards.
- Handle and dispose cleaning waste material and demolition debris in a manner that does not cause contamination of water. Dispose of sweeping material from a pick-up sweeper at an appropriate disposal site.

***Maintenance Standards*** Continually monitor operations to determine whether slurry, cuttings, or process water could enter waters of the state. If inspections show that a violation of water quality standards could occur, stop operations and immediately implement preventive measures such as berms, barriers, secondary containment, and vacuum trucks.

## **BMP C200: Interceptor Dike and Swale**

### ***Purpose***

Provide a ridge of compacted soil, or a ridge with an upslope swale, at the top or base of a disturbed slope or along the perimeter of a disturbed construction area to convey stormwater. Use the dike and/or swale to intercept the runoff from unprotected areas and direct it to areas where erosion can be controlled. This can prevent storm runoff from entering the work area or sediment-laden runoff from leaving the construction site.

### ***Conditions of Use***

Where the runoff from an exposed site or disturbed slope must be conveyed to an erosion control facility which can safely convey the stormwater.

- Locate upslope of a construction site to prevent runoff from entering disturbed area.
- When placed horizontally across a disturbed slope, it reduces the amount and velocity of runoff flowing down the slope.
- Locate downslope to collect runoff from a disturbed area and direct water to a sediment basin.

### ***Design and Installation Specifications***

- Dike and/or swale and channel must be stabilized with temporary or permanent vegetation or other channel protection during construction.
- Channel requires a positive grade for drainage; steeper grades require channel protection and check dams.
- Review construction for areas where overtopping may occur.
- Can be used at top of new fill before vegetation is established.
- May be used as a permanent diversion channel to carry the runoff.
- Sub-basin tributary area should be one acre or less.
- Design capacity for the peak flow from a 10-year, 24-hour storm, assuming a Type 1A rainfall distribution, for temporary facilities. Alternatively, use 1.6 times the 10-year, 1-hour flow indicated by an approved continuous runoff model. For facilities that will also serve on a permanent basis, consult the local government's drainage requirements.

**Interceptor dikes** shall meet the following criteria:

Top Width	2 feet minimum.
Height	1.5 feet minimum on berm.
Side Slope	2H:1V or flatter.
Grade	Depends on topography, however, dike system minimum is 0.5%, and maximum is 1%.
Compaction	Minimum of 90 percent ASTM D698 standard proctor.

Horizontal Spacing of Interceptor Dikes:

Average Slope	Slope Percent	Flowpath Length
20H:1V or less	3-5%	300 feet
(10 to 20)H:1V	5-10%	200 feet
(4 to 10)H:1V	10-25%	100 feet
(2 to 4)H:1V	25-50%	50 feet

Stabilization depends on velocity and reach

Slopes <5% Seed and mulch applied within 5 days of dike construction (see [BMP C121, Mulching](#)).

Slopes 5 - 40% Dependent on runoff velocities and dike materials. Stabilization should be done immediately using either sod or riprap or other measures to avoid erosion.

- The upslope side of the dike shall provide positive drainage to the dike outlet. No erosion shall occur at the outlet. Provide energy dissipation measures as necessary. Sediment-laden runoff must be released through a sediment trapping facility.
- Minimize construction traffic over temporary dikes. Use temporary cross culverts for channel crossing.

**Interceptor swales** shall meet the following criteria:

Bottom Width 2 feet minimum; the cross-section bottom shall be level.

Depth 1-foot minimum.

Side Slope 2H:1V or flatter.

Grade Maximum 5 percent, with positive drainage to a suitable outlet (such as a sediment pond).

Stabilization Seed as per [BMP C120, Temporary and Permanent Seeding](#), or [BMP C202, Channel Lining](#), 12 inches thick riprap pressed into the bank and extending at least 8 inches vertical from the bottom.

- Inspect diversion dikes and interceptor swales once a week and after every rainfall. Immediately remove sediment from the flow area.
- Damage caused by construction traffic or other activity must be repaired before the end of each working day.

Check outlets and make timely repairs as needed to avoid gully formation. When the area below the temporary diversion dike is permanently stabilized, remove the dike and fill and stabilize the channel to blend with the natural surface.

## **BMP C201: Grass-Lined Channels**

**Purpose** To provide a channel with a vegetative lining for conveyance of runoff. See [Figure 4.2.1](#) for typical grass-lined channels.

**Conditions of Use** This practice applies to construction sites where concentrated runoff needs to be contained to prevent erosion or flooding.

- When a vegetative lining can provide sufficient stability for the channel cross section and at lower velocities of water (normally dependent on grade). This means that the channel slopes are generally less than 5 percent and space is available for a relatively large cross section.
- Typical uses include roadside ditches, channels at property boundaries, outlets for diversions, and other channels and drainage ditches in low areas.
- Channels that will be vegetated should be installed before major earthwork and hydroseeded with a bonded fiber matrix (BFM). The vegetation should be well established (i.e., 75 percent cover) before water is allowed to flow in the ditch. With channels that will have high flows, erosion control blankets should be installed over the hydroseed. If vegetation cannot be established from seed before water is allowed in the ditch, sod should be installed in the bottom of the ditch in lieu of hydromulch and blankets.

### ***Design and Installation Specifications***

Locate the channel where it can conform to the topography and other features such as roads.

- Locate them to use natural drainage systems to the greatest extent possible.
- Avoid sharp changes in alignment or bends and changes in grade.
- Do not reshape the landscape to fit the drainage channel.
- The maximum design velocity shall be based on soil conditions, type of vegetation, and method of revegetation, but at no times shall velocity exceed 5 feet/second. The channel shall not be overtopped by the peak runoff from a 10-year, 24-hour storm, assuming a Type 1A rainfall distribution." Alternatively, use 1.6 times the 10-year, 1-hour flow indicated by an approved continuous runoff model to determine a flow rate which the channel must contain.
- Where the grass-lined channel will also function as a permanent stormwater conveyance facility, consult the drainage conveyance requirements of the local government with jurisdiction.

- An established grass or vegetated lining is required before the channel can be used to convey stormwater, unless stabilized with nets or blankets.
- If design velocity of a channel to be vegetated by seeding exceeds 2 ft/sec, a temporary channel liner is required. Geotextile or special mulch protection such as fiberglass roving or straw and netting provides stability until the vegetation is fully established. See [Figure 4.2.2](#).
- Check dams shall be removed when the grass has matured sufficiently to protect the ditch or swale unless the slope of the swale is greater than 4 percent. The area beneath the check dams shall be seeded and mulched immediately after dam removal.
- If vegetation is established by sodding, the permissible velocity for established vegetation may be used and no temporary liner is needed.
- Do not subject grass-lined channel to sedimentation from disturbed areas. Use sediment-trapping BMPs upstream of the channel.
- V-shaped grass channels generally apply where the quantity of water is small, such as in short reaches along roadsides. The V-shaped cross section is least desirable because it is difficult to stabilize the bottom where velocities may be high.
- Trapezoidal grass channels are used where runoff volumes are large and slope is low so that velocities are nonerosive to vegetated linings. (Note: it is difficult to construct small parabolic shaped channels.)
- Subsurface drainage, or riprap channel bottoms, may be necessary on sites that are subject to prolonged wet conditions due to long duration flows or a high water table.
- Provide outlet protection at culvert ends and at channel intersections.
- Grass channels, at a minimum, should carry peak runoff for temporary construction drainage facilities from the 10-year, 24-hour storm without eroding. Where flood hazard exists, increase the capacity according to the potential damage.
- Grassed channel side slopes generally are constructed 3H:1V or flatter to aid in the establishment of vegetation and for maintenance.
- Construct channels a minimum of 0.2 foot larger around the periphery to allow for soil bulking during seedbed preparations and sod buildup.

***Maintenance Standards***

During the establishment period, check grass-lined channels after every rainfall.

- After grass is established, periodically check the channel; check it after every heavy rainfall event. Immediately make repairs.
- It is particularly important to check the channel outlet and all road crossings for bank stability and evidence of piping or scour holes.

- Remove all significant sediment accumulations to maintain the designed carrying capacity. Keep the grass in a healthy, vigorous condition at all times, since it is the primary erosion protection for the channel.

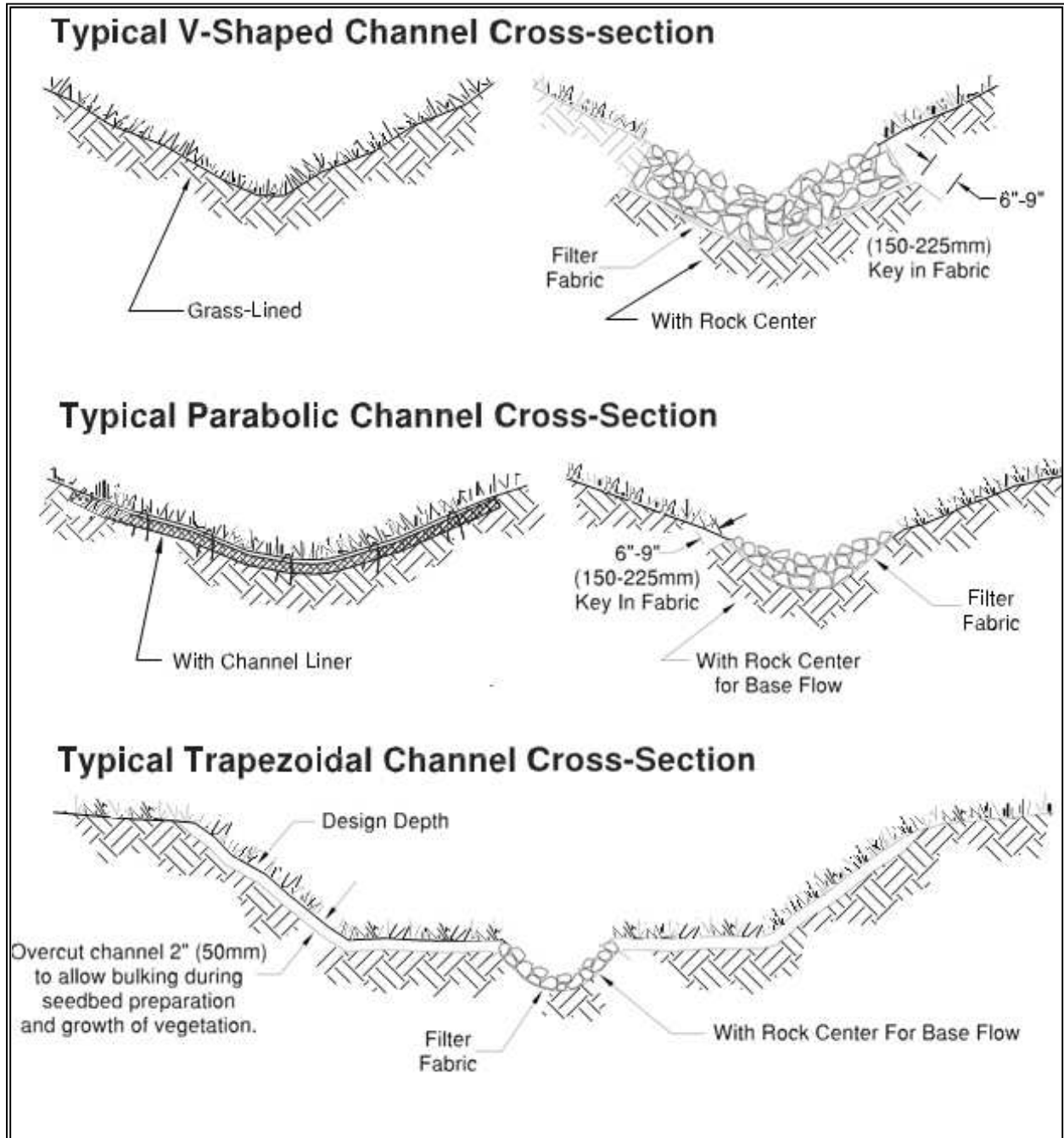
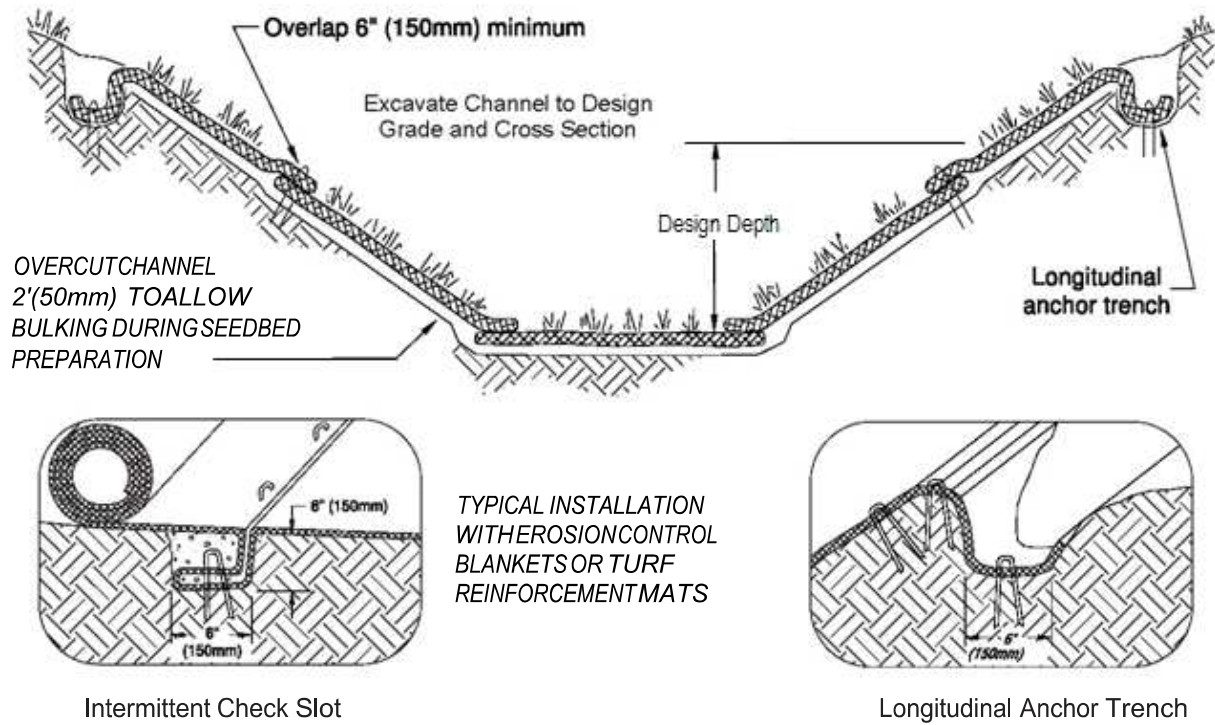

Figure 4.2.1 – Typical Grass-Lined Channels





Shingle-lap spliced ends or begin new roll in an intermittent check slot

Prepare soil and apply seed before installing blankets, mats or other temporary channel liner system

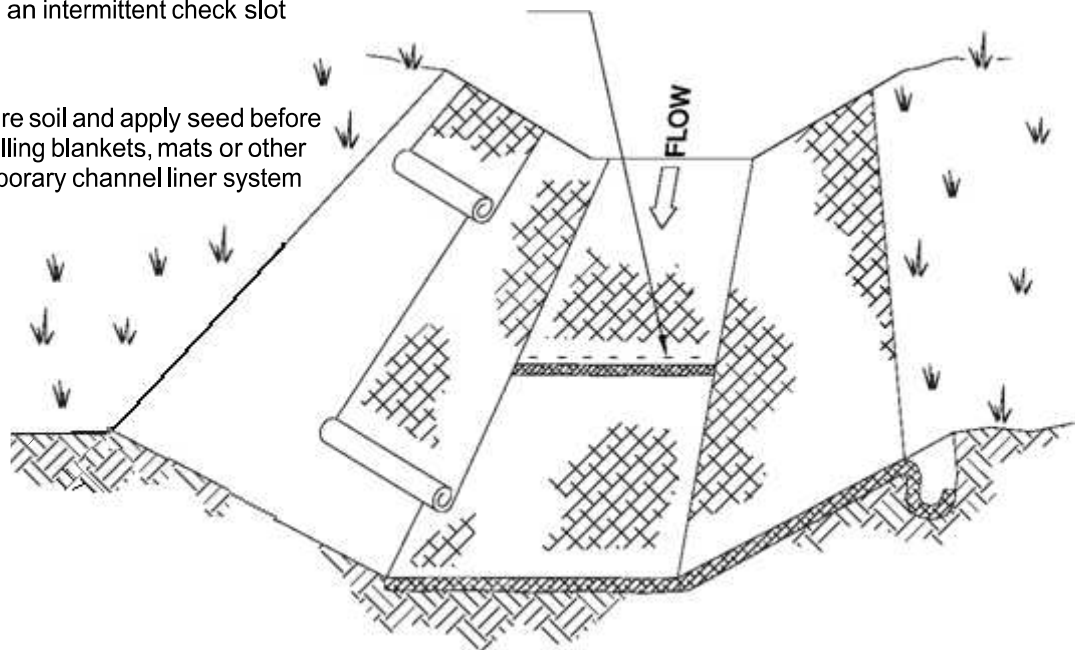

**NOTES:**

- 1 Design velocities exceeding 2 ft/sec (0.5m/sec) require temporary blankets, mats or similar liners to protect seed and soil until vegetation becomes established.
- 2 Grass-lined channels with design velocities exceeding 6 ft/sec (2m/sec) should include turf reinforcement mats.

**Figure 4.2.2 – Temporary Channel Liners**

## **BMP C202: Channel Lining**

### ***Purpose***

To protect channels by providing a channel liner using either blankets or riprap.

### ***Conditions of Use***

When natural soils or vegetated stabilized soils in a channel are not adequate to prevent channel erosion.

- When a permanent ditch or pipe system is to be installed and a temporary measure is needed.
- In almost all cases, synthetic and organic coconut blankets are more effective than riprap for protecting channels from erosion. Blankets can be used with and without vegetation. Blanketed channels can be designed to handle any expected flow and longevity requirement. Some synthetic blankets have a predicted life span of 50 years or more, even in sunlight.
- Other reasons why blankets are better than rock include the availability of blankets over rock. In many areas of the state, rock is not easily obtainable or is very expensive to haul to a site. Blankets can be delivered anywhere. Rock requires the use of dump trucks to haul and heavy equipment to place. Blankets usually only require laborers with hand tools, and sometimes a backhoe.
- The Federal Highway Administration recommends not using flexible liners whenever the slope exceeds 10 percent or the shear stress exceeds 8 lbs/ft<sup>2</sup>.

### ***Design and Installation Specifications***

See [BMP C122](#) for information on blankets.

Since riprap is used where erosion potential is high, construction must be sequenced so that the riprap is put in place with the minimum possible delay.

- Disturbance of areas where riprap is to be placed should be undertaken only when final preparation and placement of the riprap can follow immediately behind the initial disturbance. Where riprap is used for outlet protection, the riprap should be placed before or in conjunction with the construction of the pipe or channel so that it is in place when the pipe or channel begins to operate.
- The designer, after determining the riprap size that will be stable under the flow conditions, shall consider that size to be a minimum size and then, based on riprap gradations actually available in the area, select the size or sizes that equal or exceed the minimum size. The possibility of drainage structure damage by children shall be considered in selecting a riprap size, especially if there is nearby water or a gully in which to toss the stones.
- Stone for riprap shall consist of field stone or quarry stone of approximately rectangular shape. The stone shall be hard and angular

and of such quality that it will not disintegrate on exposure to water or weathering and it shall be suitable in all respects for the purpose intended.

- A lining of engineering filter fabric (geotextile) shall be placed between the riprap and the underlying soil surface to prevent soil movement into or through the riprap. The geotextile should be keyed in at the top of the bank.
- Filter fabric shall not be used on slopes greater than 1-1/2H:1V as slippage may occur. It should be used in conjunction with a layer of coarse aggregate (granular filter blanket) when the riprap to be placed is 12 inches and larger.

**BMP C203: Water Bars**

***Purpose***

A small ditch or ridge of material is constructed diagonally across a road or right-of-way to divert stormwater runoff from the road surface, wheel tracks, or a shallow road ditch. See [Figure 4.2.3](#).

***Conditions of use***

Clearing right-of-way and construction of access for power lines, pipelines, and other similar installations often require long narrow right-of-ways over sloping terrain. Disturbance and compaction promotes gully formation in these cleared strips by increasing the volume and velocity of runoff. Gully formation may be especially severe in tire tracks and ruts. To prevent gullying, runoff can often be diverted across the width of the right-of-way to undisturbed areas by using small pre-designed diversions.

- Give special consideration to each individual outlet area, as well as to the cumulative effect of added diversions. Use gravel to stabilize the diversion where significant vehicular traffic is anticipated.

***Design and Installation Specifications***

Height: 8-inch minimum measured from the channel bottom to the ridge top.

- Side slope of channel: 2H:1V maximum; 3H:1V or flatter when vehicles will cross.
- Base width of ridge: 6-inch minimum.
- Locate them to use natural drainage systems and to discharge into well vegetated stable areas.
- Guideline for Spacing:

Slope %	Spacing (ft)
< 5	125
5 - 10	100
10 - 20	75
20 - 35	50
> 35	Use rock lined ditch

## **BMP C204: Pipe Slope Drains**

**Purpose** To use a pipe to convey stormwater anytime water needs to be diverted away from or over bare soil to prevent gullies, channel erosion, and saturation of slide-prone soils.

**Conditions of Use** Pipe slope drains should be used when a temporary or permanent stormwater conveyance is needed to move the water down a steep slope to avoid erosion ([Figure 4.2.4](#)).

On highway projects, pipe slope drains should be used at bridge ends to collect runoff and pipe it to the base of the fill slopes along bridge approaches. These can be designed into a project and included as bid items. Another use on road projects is to collect runoff from pavement and pipe it away from side slopes. These are useful because there is generally a time lag between having the first lift of asphalt installed and the curbs, gutters, and permanent drainage installed. Used in conjunction with sand bags, or other temporary diversion devices, these will prevent massive amounts of sediment from leaving a project.

Water can be collected, channeled with sand bags, Triangular Silt Dikes, berms, or other material, and piped to temporary sediment ponds.

Pipe slope drains can be:

- Connected to new catch basins and used temporarily until all permanent piping is installed;
- Used to drain water collected from aquifers exposed on cut slopes and take it to the base of the slope;
- Used to collect clean runoff from plastic sheeting and direct it away from exposed soil;
- Installed in conjunction with silt fence to drain collected water to a controlled area;
- Used to divert small seasonal streams away from construction. They have been used successfully on culvert replacement and extension jobs. Large flex pipe can be used on larger streams during culvert removal, repair, or replacement; and,
- Connected to existing down spouts and roof drains and used to divert water away from work areas during building renovation, demolition, and construction projects.

There are now several commercially available collectors that are attached to the pipe inlet and help prevent erosion at the inlet.

***Design and  
Installation  
Specifications***

Size the pipe to convey the flow. The capacity for temporary drains shall be sufficient to handle the peak flow from a 10-year, 24-hour storm event, assuming a Type 1A rainfall distribution. Alternatively, use 1.6 times the 10-year, 1-hour flow indicated by an approved continuous runoff model.

Consult local drainage requirements for sizing permanent pipe slope drains.

- Use care in clearing vegetated slopes for installation.
- Re-establish cover immediately on areas disturbed by installation.
- Use temporary drains on new cut or fill slopes.
- Use diversion dikes or swales to collect water at the top of the slope.
- Ensure that the entrance area is stable and large enough to direct flow into the pipe.
- Piping of water through the berm at the entrance area is a common failure mode.
- The entrance shall consist of a standard flared end section for culverts 12 inches and larger with a minimum 6-inch metal toe plate to prevent runoff from undercutting the pipe inlet. The slope of the entrance shall be at least 3 percent. Sand bags may also be used at pipe entrances as a temporary measure.
- The soil around and under the pipe and entrance section shall be thoroughly compacted to prevent undercutting.
- The flared inlet section shall be securely connected to the slope drain and have watertight connecting bands.
- Slope drain sections shall be securely fastened together, fused or have gasketed watertight fittings, and shall be securely anchored into the soil.
- Thrust blocks should be installed anytime 90 degree bends are utilized. Depending on size of pipe and flow, these can be constructed with sand bags, straw bales staked in place, “t” posts and wire, or ecology blocks.
- Pipe needs to be secured along its full length to prevent movement. This can be done with steel “t” posts and wire. A post is installed on each side of the pipe and the pipe is wired to them. This should be done every 10-20 feet of pipe length or so, depending on the size of the pipe and quantity of water to divert.
- Interceptor dikes shall be used to direct runoff into a slope drain. The height of the dike shall be at least 1 foot higher at all points than the top of the inlet pipe.
- The area below the outlet must be stabilized with a riprap apron (see [BMP C209](#) Outlet Protection, for the appropriate outlet material).

- If the pipe slope drain is conveying sediment-laden water, direct all flows into the sediment trapping facility.
- Materials specifications for any permanent piped system shall be set by the local government.

***Maintenance Standards***

Check inlet and outlet points regularly, especially after storms.

The inlet should be free of undercutting, and no water should be going around the point of entry. If there are problems, the headwall should be reinforced with compacted earth or sand bags.

- The outlet point should be free of erosion and installed with appropriate outlet protection.
- For permanent installations, inspect pipe periodically for vandalism and physical distress such as slides and wind-throw.
- Normally the pipe slope is so steep that clogging is not a problem with smooth wall pipe, however, debris may become lodged in the pipe.

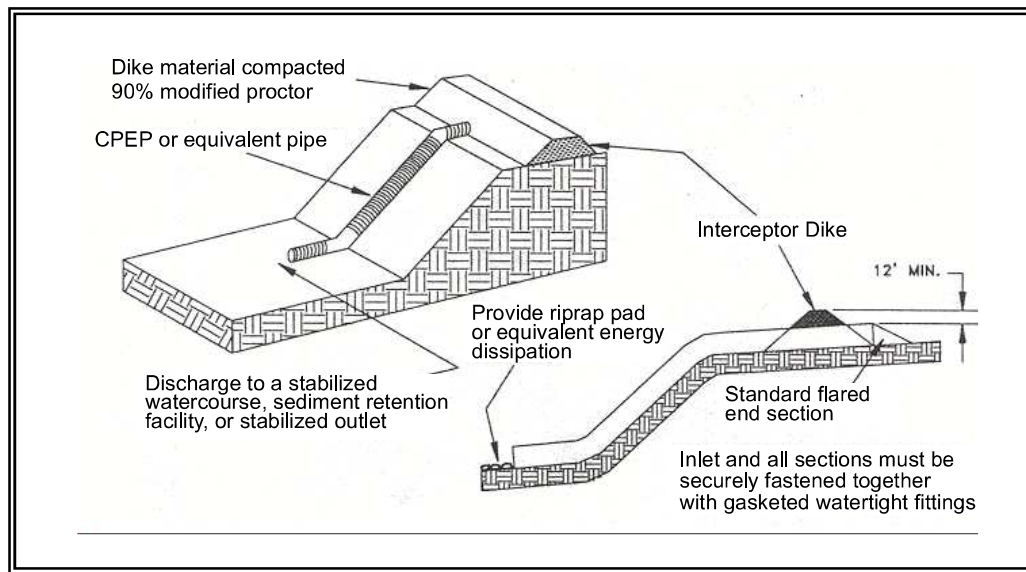

**Figure 4.2.4 – Pipe Slope Drain**



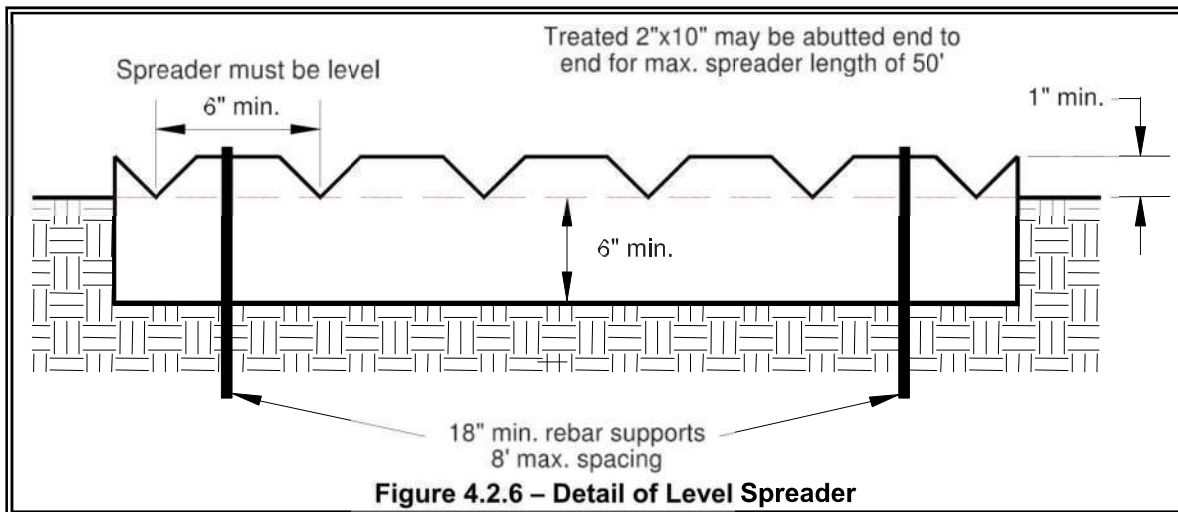

## BMP C207: Check Dams

### *Purpose*

Construction of small dams across a swale or ditch reduces the velocity of concentrated flow and dissipates energy at the check dam.

### *Conditions of Use*

Where temporary channels or permanent channels are not yet vegetated, channel lining is infeasible, and/or velocity checks are required.

- Check dams may not be placed in streams unless approved by the State Department of Fish and Wildlife. Check dams may not be placed in wetlands without approval from a permitting agency.
- Do not place check dams below the expected backwater from any salmonid bearing water between October 1 and May 31 to ensure that there is no loss of high flow refuge habitat for overwintering juvenile salmonids and emergent salmonid fry.
- Construct rock check dams from appropriately sized rock. The rock used must be large enough to stay in place given the expected design flow through the channel. The rock must be placed by hand or by mechanical means (no dumping of rock to form dam) to achieve complete coverage of the ditch or swale and to ensure that the center of the dam is lower than the edges.
- Check dams may also be constructed of either rock or pea-gravel filled bags. Numerous new products are also available for this purpose. They tend to be re-usable, quick and easy to install, effective, and cost efficient.
- Place check dams perpendicular to the flow of water.
- The dam should form a triangle when viewed from the side. This prevents undercutting as water flows over the face of the dam rather than falling directly onto the ditch bottom.

- Before installing check dams impound and bypass upstream water flow away from the work area. Options for bypassing include pumps, siphons, or temporary channels.
- Check dams in association with sumps work more effectively at slowing flow and retaining sediment than just a check dam alone. A deep sump should be provided immediately upstream of the check dam.
- In some cases, if carefully located and designed, check dams can remain as permanent installations with very minor regrading. They may be left as either spillways, in which case accumulated sediment would be graded and seeded, or as check dams to prevent further sediment from leaving the site.
- The maximum spacing between the dams shall be such that the toe of the upstream dam is at the same elevation as the top of the downstream dam.
- Keep the maximum height at 2 feet at the center of the dam.
- Keep the center of the check dam at least 12 inches lower than the outer edges at natural ground elevation.
- Keep the side slopes of the check dam at 2H:1V or flatter.
- Key the stone into the ditch banks and extend it beyond the abutments a minimum of 18 inches to avoid washouts from overflow around the dam.
- Use filter fabric foundation under a rock or sand bag check dam. If a blanket ditch liner is used, filter fabric is not necessary. A piece of organic or synthetic blanket cut to fit will also work for this purpose.
- In the case of grass-lined ditches and swales, all check dams and accumulated sediment shall be removed when the grass has matured sufficiently to protect the ditch or swale - unless the slope of the swale is greater than 4 percent. The area beneath the check dams shall be seeded and mulched immediately after dam removal.
- Ensure that channel appurtenances, such as culvert entrances below check dams, are not subject to damage or blockage from displaced stones. [Figure 4.2.7](#) depicts a typical rock check dam.

***Maintenance Standards***

Check dams shall be monitored for performance and sediment accumulation during and after each runoff producing rainfall. Sediment shall be removed when it reaches one half the sump depth.

- Anticipate submergence and deposition above the check dam and erosion from high flows around the edges of the dam.
- If significant erosion occurs between dams, install a protective riprap liner in that portion of the channel.



***Approved as  
Equivalent***

Ecology has approved products as able to meet the requirements of [BMP C207](#). The products did not pass through the Technology Assessment Protocol – Ecology (TAPE) process. Local jurisdictions may choose not to accept this product approved as equivalent, or may require additional testing prior to consideration for local use. The products are available for review on Ecology’s website at <http://www.ecy.wa.gov/programs/wq/stormwater/newtech/equivalent.html>

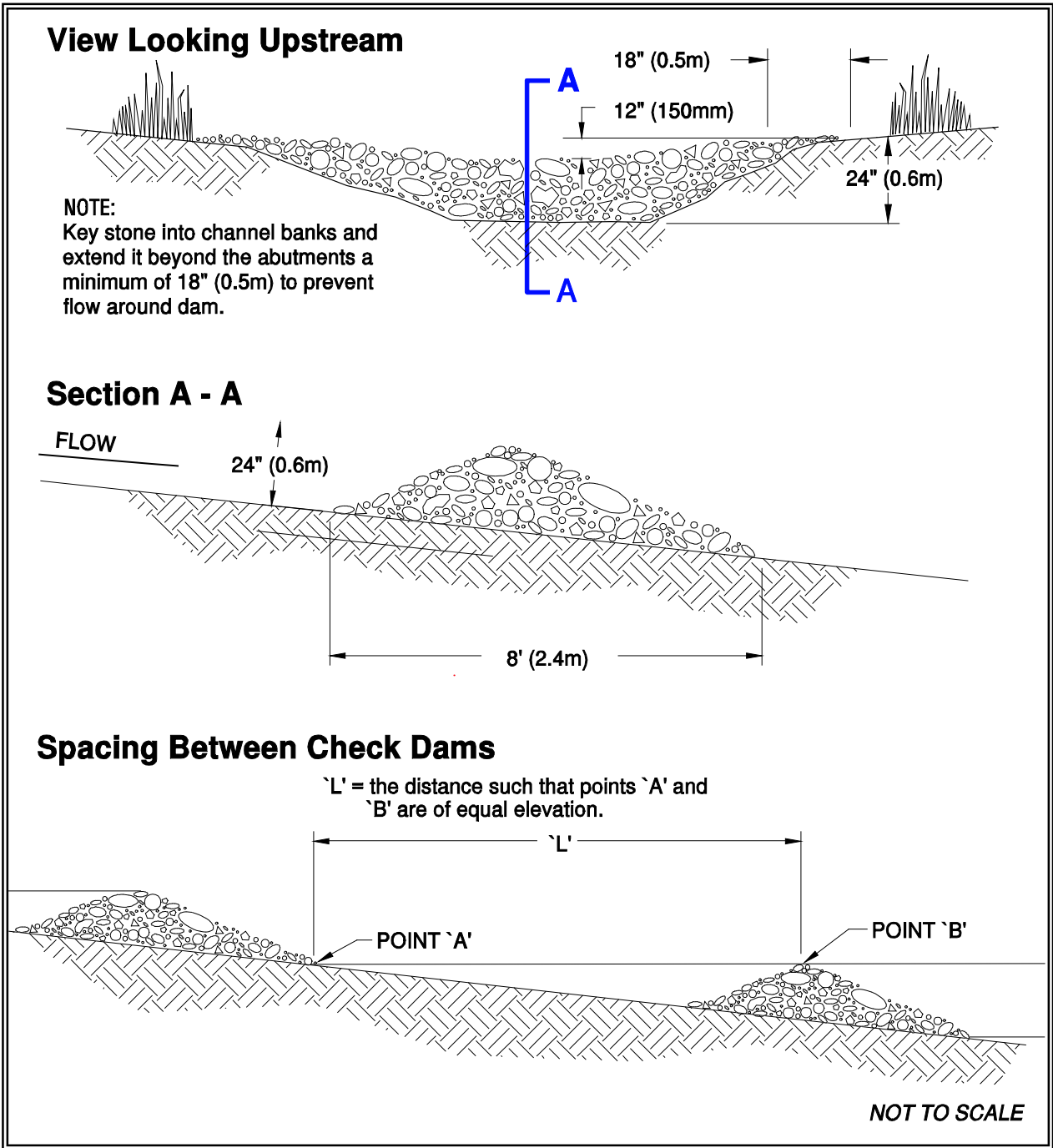

Figure 4.2.7 – Rock Check Dam

## ***Standards***

accumulation during and after each runoff producing rainfall. Sediment shall be removed when it reaches one half the height of the dam.

- Anticipate submergence and deposition above the triangular silt dam and erosion from high flows around the edges of the dam. Immediately repair any damage or any undercutting of the dam.

## **BMP C209: Outlet Protection**

### ***Purpose***

Outlet protection prevents scour at conveyance outlets and minimizes the potential for downstream erosion by reducing the velocity of concentrated stormwater flows.

### ***Conditions of use***

Outlet protection is required at the outlets of all ponds, pipes, ditches, or other conveyances, and where runoff is conveyed to a natural or manmade drainage feature such as a stream, wetland, lake, or ditch.

### ***Design and Installation Specifications***

The receiving channel at the outlet of a culvert shall be protected from erosion by rock lining a minimum of 6 feet downstream and extending up the channel sides a minimum of 1-foot above the maximum tailwater elevation or 1-foot above the crown, whichever is higher. For large pipes (more than 18 inches in diameter), the outlet protection lining of the channel is lengthened to four times the diameter of the culvert.

- Standard wingwalls, and tapered outlets and paved channels should also be considered when appropriate for permanent culvert outlet protection. (See WSDOT Hydraulic Manual, available through WSDOT Engineering Publications).
- Organic or synthetic erosion blankets, with or without vegetation, are usually more effective than rock, cheaper, and easier to install. Materials can be chosen using manufacturer product specifications. ASTM test results are available for most products and the designer can choose the correct material for the expected flow.
- With low flows, vegetation (including sod) can be effective.
- The following guidelines shall be used for riprap outlet protection:
  1. If the discharge velocity at the outlet is less than 5 fps (pipe slope less than 1 percent), use 2-inch to 8-inch riprap. Minimum thickness is 1-foot.
  2. For 5 to 10 fps discharge velocity at the outlet (pipe slope less than 3 percent), use 24-inch to 48-inch riprap. Minimum thickness is 2 feet.
  3. For outlets at the base of steep slope pipes (pipe slope greater than 10 percent), an engineered energy dissipater shall be used.
- Filter fabric or erosion control blankets should always be used under riprap to prevent scour and channel erosion.

- New pipe outfalls can provide an opportunity for low-cost fish habitat improvements. For example, an alcove of low-velocity water can be created by constructing the pipe outfall and associated energy dissipater back from the stream edge and digging a channel, over-widened to the upstream side, from the outfall. Overwintering juvenile and migrating adult salmonids may use the alcove as shelter during high flows. Bank stabilization, bioengineering, and habitat features may be required for disturbed areas. This work may require a HPA. See Volume V for more information on outfall system design.

***Maintenance Standards***

- Inspect and repair as needed.
- Add rock as needed to maintain the intended function.
- Clean energy dissipater if sediment builds up.

**BMP C220: Storm Drain Inlet Protection**

***Purpose***

Storm drain inlet protection prevents coarse sediment from entering drainage systems prior to permanent stabilization of the disturbed area.

***Conditions of Use***

Use storm drain inlet protection at inlets that are operational before permanent stabilization of the disturbed drainage area. Provide protection for all storm drain inlets downslope and within 500 feet of a disturbed or construction area, unless conveying runoff entering catch basins to a sediment pond or trap.

Also consider inlet protection for lawn and yard drains on new home construction. These small and numerous drains coupled with lack of gutters in new home construction can add significant amounts of sediment into the roof drain system. If possible delay installing lawn and yard drains until just before landscaping or cap these drains to prevent sediment from entering the system until completion of landscaping. Provide 18-inches of sod around each finished lawn and yard drain.

[Table 4.2.2](#) lists several options for inlet protection. All of the methods for storm drain inlet protection tend to plug and require a high frequency of maintenance. Limit drainage areas to one acre or less. Possibly provide emergency overflows with additional end-of-pipe treatment where stormwater ponding would cause a hazard.

**Table 4.2.2  
Storm Drain Inlet Protection**

<b>Type of Inlet Protection</b>	<b>Emergency Overflow</b>	<b>Applicable for Paved/ Earthen Surfaces</b>	<b>Conditions of Use</b>
<b>Drop Inlet Protection</b>			
Excavated drop inlet protection	Yes, temporary flooding will occur	Earthen	Applicable for heavy flows. Easy to maintain. Large area Requirement: 30' X 30'/acre
Block and gravel drop inlet protection	Yes	Paved or Earthen	Applicable for heavy concentrated flows. Will not pond.
Gravel and wire drop inlet protection	No		Applicable for heavy concentrated flows. Will pond. Can withstand traffic.
Catch basin filters	Yes	Paved or Earthen	Frequent maintenance required.
<b>Curb Inlet Protection</b>			
Curb inlet protection with a wooden weir	Small capacity overflow	Paved	Used for sturdy, more compact installation.
Block and gravel curb inlet protection	Yes	Paved	Sturdy, but limited filtration.
<b>Culvert Inlet Protection</b>			
Culvert inlet sediment trap			18 month expected life.

***Design and Installation Specifications***

*Excavated Drop Inlet Protection* - An excavated impoundment around the storm drain. Sediment settles out of the stormwater prior to entering the storm drain.

- Provide a depth of 1-2 ft as measured from the crest of the inlet structure.
- Slope sides of excavation no steeper than 2H:1V.
- Minimum volume of excavation 35 cubic yards.
- Shape basin to fit site with longest dimension oriented toward the longest inflow area.
- Install provisions for draining to prevent standing water problems.
- Clear the area of all debris.
- Grade the approach to the inlet uniformly.
- Drill weep holes into the side of the inlet.
- Protect weep holes with screen wire and washed aggregate.
- Seal weep holes when removing structure and stabilizing area.

- Build a temporary dike, if necessary, to the down slope side of the structure to prevent bypass flow.

*Block and Gravel Filter* - A barrier formed around the storm drain inlet with standard concrete blocks and gravel. See [Figure 4.2.8](#).

- Provide a height of 1 to 2 feet above inlet.
- Recess the first row 2-inches into the ground for stability.
- Support subsequent courses by placing a 2x4 through the block opening.
- Do not use mortar.
- Lay some blocks in the bottom row on their side for dewatering the pool.
- Place hardware cloth or comparable wire mesh with ½-inch openings over all block openings.
- Place gravel just below the top of blocks on slopes of 2H:1V or flatter.
- An alternative design is a gravel donut.
- Provide an inlet slope of 3H:1V.
- Provide an outlet slope of 2H:1V.
- Provide a 1-foot wide level stone area between the structure and the inlet.
- Use inlet slope stones 3 inches in diameter or larger.
- Use gravel ½- to ¾-inch at a minimum thickness of 1-foot for the outlet slope.

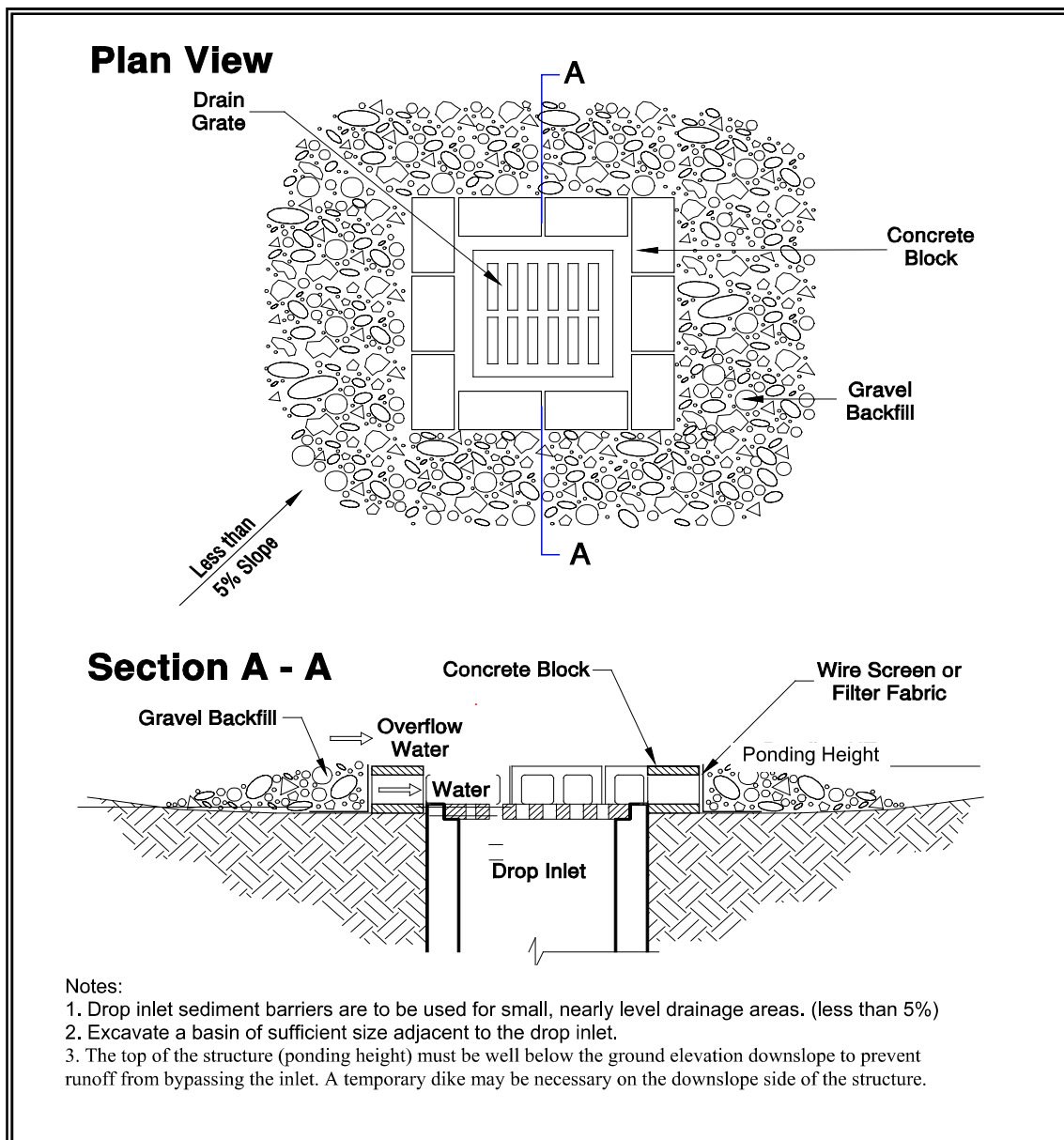

**Figure 4.2.8 – Block and Gravel Filter**

*Gravel and Wire Mesh Filter* - A gravel barrier placed over the top of the inlet. This structure does not provide an overflow.

- Use a hardware cloth or comparable wire mesh with ½-inch openings.
- Use coarse aggregate.
- Provide a height 1-foot or more, 18-inches wider than inlet on all sides.
- Place wire mesh over the drop inlet so that the wire extends a minimum of 1-foot beyond each side of the inlet structure.
- Overlap the strips if more than one strip of mesh is necessary.

- Place coarse aggregate over the wire mesh.
- Provide at least a 12-inch depth of gravel over the entire inlet opening and extend at least 18-inches on all sides.

*Catchbasin Filters* – Use inserts designed by manufacturers for construction sites. The limited sediment storage capacity increases the amount of inspection and maintenance required, which may be daily for heavy sediment loads. To reduce maintenance requirements combine a catchbasin filter with another type of inlet protection. This type of inlet protection provides flow bypass without overflow and therefore may be a better method for inlets located along active rights-of-way.

- Provides 5 cubic feet of storage.
- Requires dewatering provisions.
- Provides a high-flow bypass that will not clog under normal use at a construction site.
- Insert the catchbasin filter in the catchbasin just below the grating.

*Curb Inlet Protection with Wooden Weir* – Barrier formed around a curb inlet with a wooden frame and gravel.

- Use wire mesh with ½-inch openings.
- Use extra strength filter cloth.
- Construct a frame.
- Attach the wire and filter fabric to the frame.
- Pile coarse washed aggregate against wire/fabric.
- Place weight on frame anchors.

*Block and Gravel Curb Inlet Protection* – Barrier formed around a curb inlet with concrete blocks and gravel. See [Figure 4.2.9](#).

- Use wire mesh with ½-inch openings.
- Place two concrete blocks on their sides abutting the curb at either side of the inlet opening. These are spacer blocks.
- Place a 2x4 stud through the outer holes of each spacer block to align the front blocks.
- Place blocks on their sides across the front of the inlet and abutting the spacer blocks.
- Place wire mesh over the outside vertical face.
- Pile coarse aggregate against the wire to the top of the barrier.

*Curb and Gutter Sediment Barrier* – Sandbag or rock berm (riprap and aggregate) 3 feet high and 3 feet wide in a horseshoe shape. See [Figure 4.2.10](#).



***Maintenance  
Standards***

- Construct a horseshoe shaped berm, faced with coarse aggregate if using riprap, 3 feet high and 3 feet wide, at least 2 feet from the inlet.
- Construct a horseshoe shaped sedimentation trap on the outside of the berm sized to sediment trap standards for protecting a culvert inlet.
- Inspect catch basin filters frequently, especially after storm events. Clean and replace clogged inserts. For systems with clogged stone filters: pull away the stones from the inlet and clean or replace. An alternative approach would be to use the clogged stone as fill and put fresh stone around the inlet.
- Do not wash sediment into storm drains while cleaning. Spread all excavated material evenly over the surrounding land area or stockpile and stabilize as appropriate.

***Approved as  
Equivalent***

Ecology has approved products as able to meet the requirements of [BMP C220](#). The products did not pass through the Technology Assessment Protocol – Ecology (TAPE) process. Local jurisdictions may choose not to accept this product approved as equivalent, or may require additional testing prior to consideration for local use. The products are available for review on Ecology’s website at <http://www.ecy.wa.gov/programs/wq/stormwater/newtech/equivalent.html>

## Plan View

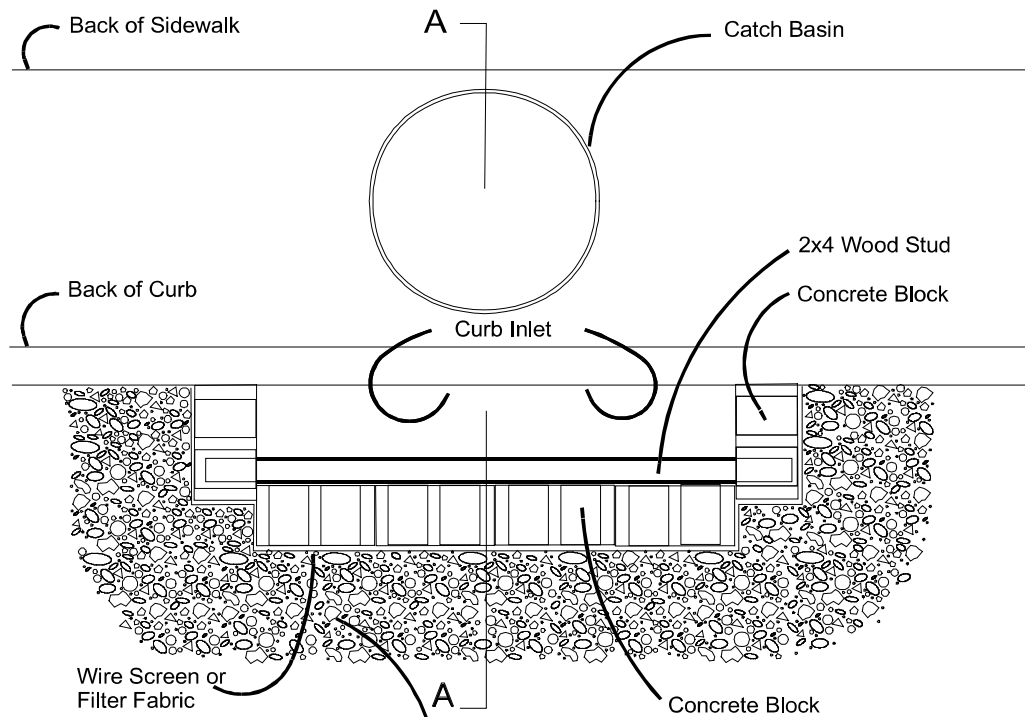

## Section A - A

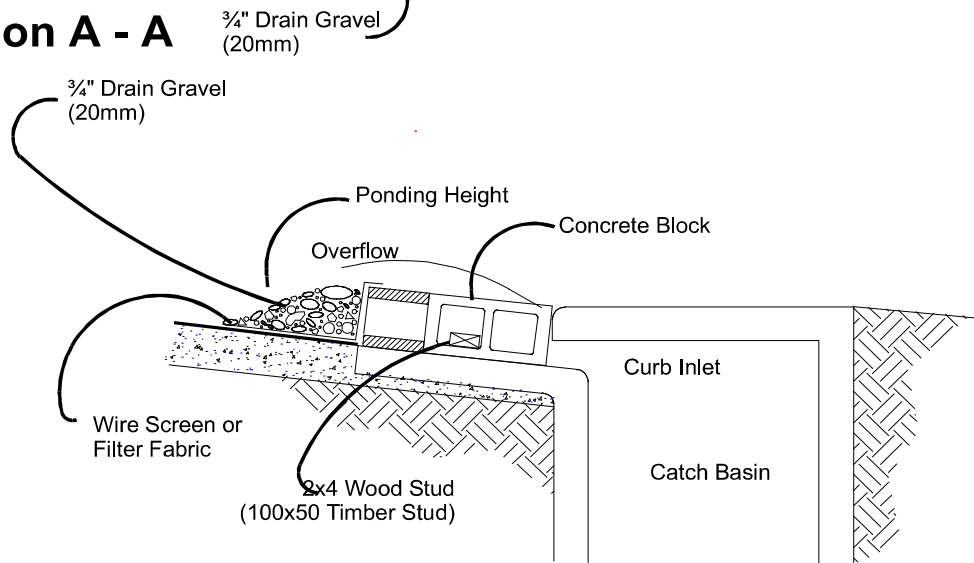

### NOTES:

1. Use block and gravel type sediment barrier when curb inlet is located in gently sloping street segment, where water can pond and allow sediment to separate from runoff.
2. Barrier shall allow for overflow from severe storm event.
3. Inspect barriers and remove sediment after each storm event. Sediment and gravel must be removed from the traveled way immediately.

**Figure 4.2.9 – Block and Gravel Curb Inlet Protection**

## Plan View

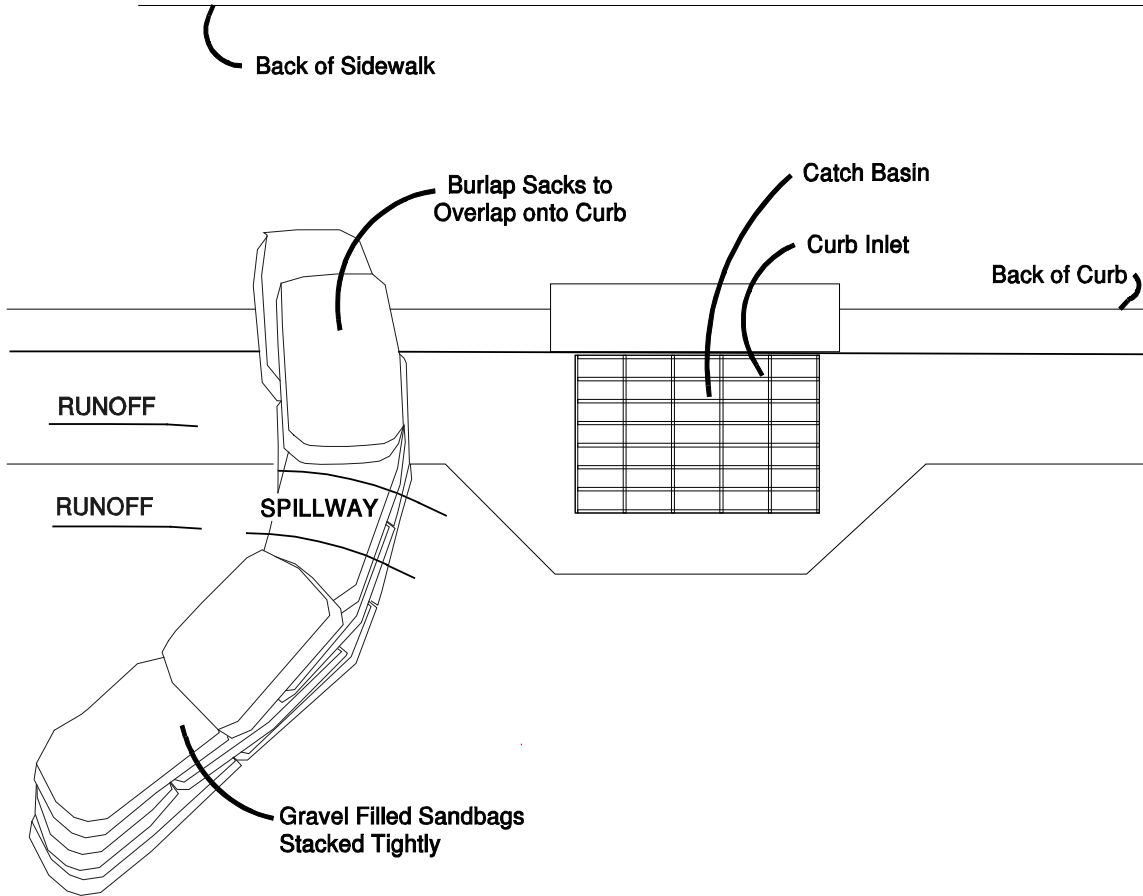

### NOTES:

1. Place curb type sediment barriers on gently sloping street segments, where water can pond and allow sediment to separate from runoff.
2. Sandbags of either burlap or woven 'geotextile' fabric, are filled with gravel, layered and packed tightly.
3. Leave a one sandbag gap in the top row to provide a spillway for overflow.
4. Inspect barriers and remove sediment after each storm event. Sediment and gravel must be removed from the traveled way immediately.

Figure 4.2.10 – Curb and Gutter Barrier

## **BMP C232: Gravel Filter Berm**

- Purpose** A gravel filter berm is constructed on rights-of-way or traffic areas within a construction site to retain sediment by using a filter berm of gravel or crushed rock.
- Conditions of Use** Where a temporary measure is needed to retain sediment from rights-of-way or in traffic areas on construction sites.
- Design and Installation Specifications**
- Berm material shall be  $\frac{3}{4}$  to 3 inches in size, washed well-grade gravel or crushed rock with less than 5 percent fines.
  - Spacing of berms:
    - Every 300 feet on slopes less than 5 percent
    - Every 200 feet on slopes between 5 percent and 10 percent
    - Every 100 feet on slopes greater than 10 percent
  - Berm dimensions:
    - 1 foot high with 3H:1V side slopes
    - 8 linear feet per 1 cfs runoff based on the 10-year, 24-hour design storm
- Maintenance Standards**
- Regular inspection is required. Sediment shall be removed and filter material replaced as needed.

## **BMP C233: Silt Fence**

- Purpose** Use of a silt fence reduces the transport of coarse sediment from a construction site by providing a temporary physical barrier to sediment and reducing the runoff velocities of overland flow. See [Figure 4.2.12](#) for details on silt fence construction.
- Conditions of Use** Silt fence may be used downslope of all disturbed areas.
- Silt fence shall prevent soil carried by runoff water from going beneath, through, or over the top of the silt fence, but shall allow the water to pass through the fence.
  - Silt fence is not intended to treat concentrated flows, nor is it intended to treat substantial amounts of overland flow. Convey any concentrated flows through the drainage system to a sediment pond.
  - Do not construct silt fences in streams or use in V-shaped ditches. Silt fences do not provide an adequate method of silt control for anything deeper than sheet or overland flow.

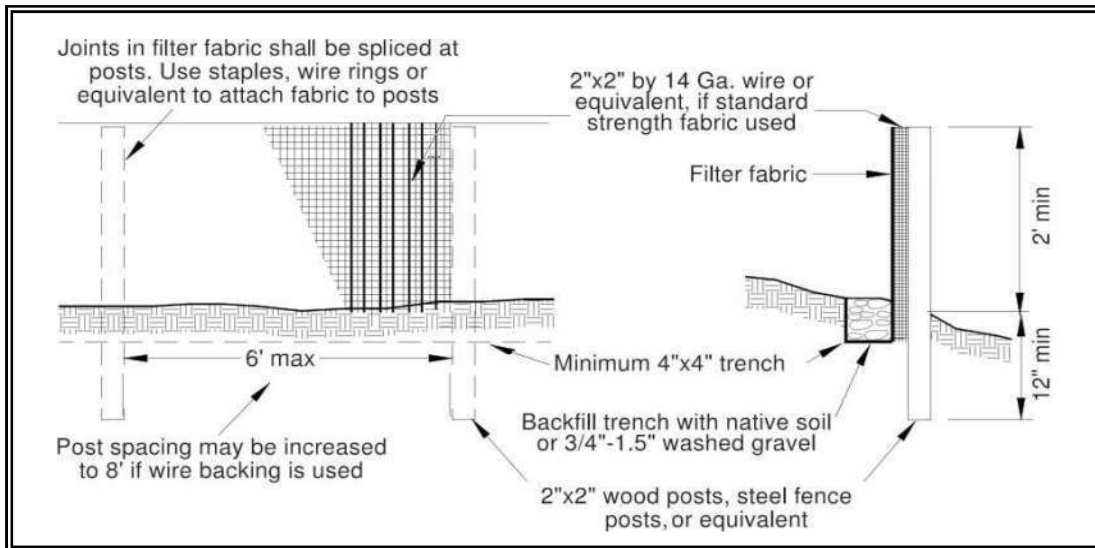

**Figure 4.2.12 – Silt Fence**

***Design and Installation Specifications***

- Use in combination with sediment basins or other BMPs.
- Maximum slope steepness (normal (perpendicular) to fence line) 1H:1V.
- Maximum sheet or overland flow path length to the fence of 100 feet.
- Do not allow flows greater than 0.5 cfs.
- The geotextile used shall meet the following standards. All geotextile properties listed below are minimum average roll values (i.e., the test result for any sampled roll in a lot shall meet or exceed the values shown in [Table 4.2.3](#)):

<b>Table 4.2.3 Geotextile Standards</b>	
Polymeric Mesh AOS (ASTM D4751)	0.60 mm maximum for slit film woven (#30 sieve). 0.30 mm maximum for all other geotextile types (#50 sieve). 0.15 mm minimum for all fabric types (#100 sieve).
Water Permittivity (ASTM D4491)	0.02 sec <sup>-1</sup> minimum
Grab Tensile Strength (ASTM D4632)	180 lbs. Minimum for extra strength fabric. 100 lbs minimum for standard strength fabric.
Grab Tensile Strength (ASTM D4632)	30% maximum
Ultraviolet Resistance (ASTM D4355)	70% minimum

- Support standard strength fabrics with wire mesh, chicken wire, 2-inch x 2-inch wire, safety fence, or jute mesh to increase the strength of the

fabric. Silt fence materials are available that have synthetic mesh backing attached.

- Filter fabric material shall contain ultraviolet ray inhibitors and stabilizers to provide a minimum of six months of expected usable construction life at a temperature range of 0°F. to 120°F.
- One-hundred percent biodegradable silt fence is available that is strong, long lasting, and can be left in place after the project is completed, if permitted by local regulations.
- Refer to [Figure 4.2.12](#) for standard silt fence details. Include the following standard Notes for silt fence on construction plans and specifications:
  1. The contractor shall install and maintain temporary silt fences at the locations shown in the Plans.
  2. Construct silt fences in areas of clearing, grading, or drainage prior to starting those activities.
  3. The silt fence shall have a 2-foot min. and a 2½-foot max. height above the original ground surface.
  4. The filter fabric shall be sewn together at the point of manufacture to form filter fabric lengths as required. Locate all sewn seams at support posts. Alternatively, two sections of silt fence can be overlapped, provided the Contractor can demonstrate, to the satisfaction of the Engineer, that the overlap is long enough and that the adjacent fence sections are close enough together to prevent silt laden water from escaping through the fence at the overlap.
  5. Attach the filter fabric on the up-slope side of the posts and secure with staples, wire, or in accordance with the manufacturer's recommendations. Attach the filter fabric to the posts in a manner that reduces the potential for tearing.
  6. Support the filter fabric with wire or plastic mesh, dependent on the properties of the geotextile selected for use. If wire or plastic mesh is used, fasten the mesh securely to the up-slope side of the posts with the filter fabric up-slope of the mesh.
  7. Mesh support, if used, shall consist of steel wire with a maximum mesh spacing of 2-inches, or a prefabricated polymeric mesh. The strength of the wire or polymeric mesh shall be equivalent to or greater than 180 lbs. grab tensile strength. The polymeric mesh must be as resistant to the same level of ultraviolet radiation as the filter fabric it supports.
  8. Bury the bottom of the filter fabric 4-inches min. below the ground surface. Backfill and tamp soil in place over the buried portion of the filter fabric, so that no flow can pass beneath the fence and

scouring cannot occur. When wire or polymeric back-up support mesh is used, the wire or polymeric mesh shall extend into the ground 3-inches min.

9. Drive or place the fence posts into the ground 18-inches min. A 12-inch min. depth is allowed if topsoil or other soft subgrade soil is not present and 18-inches cannot be reached. Increase fence post min. depths by 6 inches if the fence is located on slopes of 3H:1V or steeper and the slope is perpendicular to the fence. If required post depths cannot be obtained, the posts shall be adequately secured by bracing or guying to prevent overturning of the fence due to sediment loading.
  10. Use wood, steel or equivalent posts. The spacing of the support posts shall be a maximum of 6-feet. Posts shall consist of either:
    - Wood with dimensions of 2-inches by 2-inches wide min. and a 3-feet min. length. Wood posts shall be free of defects such as knots, splits, or gouges.
    - No. 6 steel rebar or larger.
    - ASTM A 120 steel pipe with a minimum diameter of 1-inch.
    - U, T, L, or C shape steel posts with a minimum weight of 1.35 lbs./ft.
    - Other steel posts having equivalent strength and bending resistance to the post sizes listed above.
  11. Locate silt fences on contour as much as possible, except at the ends of the fence, where the fence shall be turned uphill such that the silt fence captures the runoff water and prevents water from flowing around the end of the fence.
  12. If the fence must cross contours, with the exception of the ends of the fence, place gravel check dams perpendicular to the back of the fence to minimize concentrated flow and erosion. The slope of the fence line where contours must be crossed shall not be steeper than 3H:1V.
    - Gravel check dams shall be approximately 1-foot deep at the back of the fence. Gravel check dams shall be continued perpendicular to the fence at the same elevation until the top of the check dam intercepts the ground surface behind the fence.
    - Gravel check dams shall consist of crushed surfacing base course, gravel backfill for walls, or shoulder ballast. Gravel check dams shall be located every 10 feet along the fence where the fence must cross contours.
- Refer to [Figure 4.2.13](#) for slicing method details. Silt fence installation using the slicing method specifications:

1. The base of both end posts must be at least 2- to 4-inches above the top of the filter fabric on the middle posts for ditch checks to drain properly. Use a hand level or string level, if necessary, to mark base points before installation.
2. Install posts 3- to 4-feet apart in critical retention areas and 6- to 7-feet apart in standard applications.
3. Install posts 24-inches deep on the downstream side of the silt fence, and as close as possible to the filter fabric, enabling posts to support the filter fabric from upstream water pressure.
4. Install posts with the nipples facing away from the filter fabric.
5. Attach the filter fabric to each post with three ties, all spaced within the top 8-inches of the filter fabric. Attach each tie diagonally 45 degrees through the filter fabric, with each puncture at least 1-inch vertically apart. Each tie should be positioned to hang on a post nipple when tightening to prevent sagging.
6. Wrap approximately 6-inches of fabric around the end posts and secure with 3 ties.
7. No more than 24-inches of a 36-inch filter fabric is allowed above ground level.

Compact the soil immediately next to the filter fabric with the front wheel of the tractor, skid steer, or roller exerting at least 60 pounds per square inch. Compact the upstream side first and then each side twice for a total of four trips. Check and correct the silt fence installation for any deviation before compaction. Use a flat-bladed shovel to tuck fabric deeper into the ground if necessary.



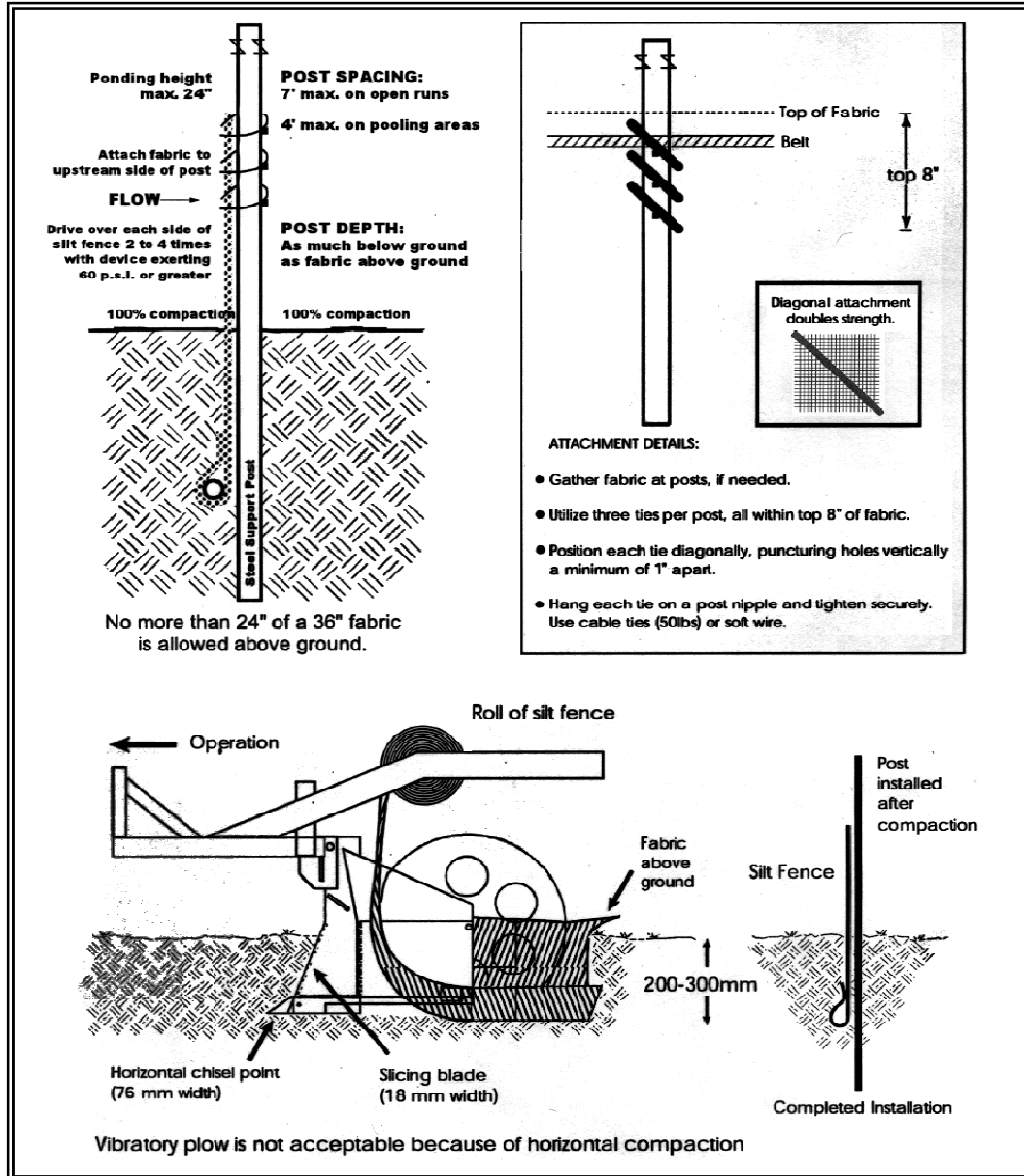

Figure 4.2.13 – Silt Fence Installation by Slicing Method

**Maintenance Standards**

- Repair any damage immediately.
- Intercept and convey all evident concentrated flows uphill of the silt fence to a sediment pond.
- Check the uphill side of the fence for signs of the fence clogging and acting as a barrier to flow and then causing channelization of flows parallel to the fence. If this occurs, replace the fence or remove the trapped sediment.

## **BMP C240: Sediment Trap**

### ***Purpose***

A sediment trap is a small temporary ponding area with a gravel outlet used to collect and store sediment from sites cleared and/or graded during construction. Sediment traps, along with other perimeter controls, shall be installed before any land disturbance takes place in the drainage area.

### ***Conditions of Use***

Prior to leaving a construction site, stormwater runoff must pass through a sediment pond or trap or other appropriate sediment removal best management practice. Non-engineered sediment traps may be used on-site prior to an engineered sediment trap or sediment pond to provide additional sediment removal capacity.

It is intended for use on sites where the tributary drainage area is less than 3 acres, with no unusual drainage features, and a projected build-out time of six months or less. The sediment trap is a temporary measure (with a design life of approximately 6 months) and shall be maintained until the site area is permanently protected against erosion by vegetation and/or structures.

Sediment traps and ponds are only effective in removing sediment down to about the medium silt size fraction. Runoff with sediment of finer grades (fine silt and clay) will pass through untreated, emphasizing the need to control erosion to the maximum extent first.

Whenever possible, sediment-laden water shall be discharged into on-site, relatively level, vegetated areas (see [BMP C234 – Vegetated Strip](#)). This is the only way to effectively remove fine particles from runoff unless chemical treatment or filtration is used. This can be particularly useful after initial treatment in a sediment trap or pond. The areas of release must be evaluated on a site-by-site basis in order to determine appropriate locations for and methods of releasing runoff. Vegetated wetlands shall not be used for this purpose. Frequently, it may be possible to pump water from the collection point at the downhill end of the site to an upslope vegetated area. Pumping shall only augment the treatment system, not replace it, because of the possibility of pump failure or runoff volume in excess of pump capacity.

All projects that are constructing permanent facilities for runoff quantity control should use the rough-graded or final-graded permanent facilities for traps and ponds. This includes combined facilities and infiltration facilities. When permanent facilities are used as temporary sedimentation facilities, the surface area requirement of a sediment trap or pond must be met. If the surface area requirements are larger than the surface area of the permanent facility, then the trap or pond shall be enlarged to comply with the surface area requirement. The permanent pond shall also be divided into two cells as required for sediment ponds.

Either a permanent control structure or the temporary control structure (described in [BMP C241](#), Temporary Sediment Pond) can be used. If a permanent control structure is used, it may be advisable to partially restrict the lower orifice with gravel to increase residence time while still allowing dewatering of the pond. A shut-off valve may be added to the control structure to allow complete retention of stormwater in emergency situations. In this case, an emergency overflow weir must be added.

A skimmer may be used for the sediment trap outlet if approved by the Local Permitting Authority.

***Design and  
Installation  
Specifications***

- See [Figures 4.2.16](#) and [4.2.17](#) for details.
- If permanent runoff control facilities are part of the project, they should be used for sediment retention.
- To determine the sediment trap geometry, first calculate the design surface area (SA) of the trap, measured at the invert of the weir. Use the following equation:

$$SA = FS(Q_2/V_s)$$

where

$Q_2$  = Design inflow based on the peak discharge from the developed 2-year runoff event from the contributing drainage area as computed in the hydrologic analysis. The 10-year peak flow shall be used if the project size, expected timing and duration of construction, or downstream conditions warrant a higher level of protection. If no hydrologic analysis is required, the Rational Method may be used.

$V_s$  = The settling velocity of the soil particle of interest. The 0.02 mm (medium silt) particle with an assumed density of 2.65 g/cm<sup>3</sup> has been selected as the particle of interest and has a settling velocity ( $V_s$ ) of 0.00096 ft/sec.

$FS$  = A safety factor of 2 to account for non-ideal settling.

Therefore, the equation for computing surface area becomes:

$$SA = 2 \times Q_2 / 0.00096 \text{ or}$$

2080 square feet per cfs of inflow

Note: Even if permanent facilities are used, they must still have a surface area that is at least as large as that derived from the above formula. If they do not, the pond must be enlarged.

- To aid in determining sediment depth, all sediment traps shall have a staff gauge with a prominent mark 1-foot above the bottom of the trap.

- Sediment traps may not be feasible on utility projects due to the limited work space or the short-term nature of the work. Portable tanks may be used in place of sediment traps for utility projects.
- Sediment shall be removed from the trap when it reaches 1-foot in depth.
- Any damage to the pond embankments or slopes shall be repaired.

**Maintenance Standards**

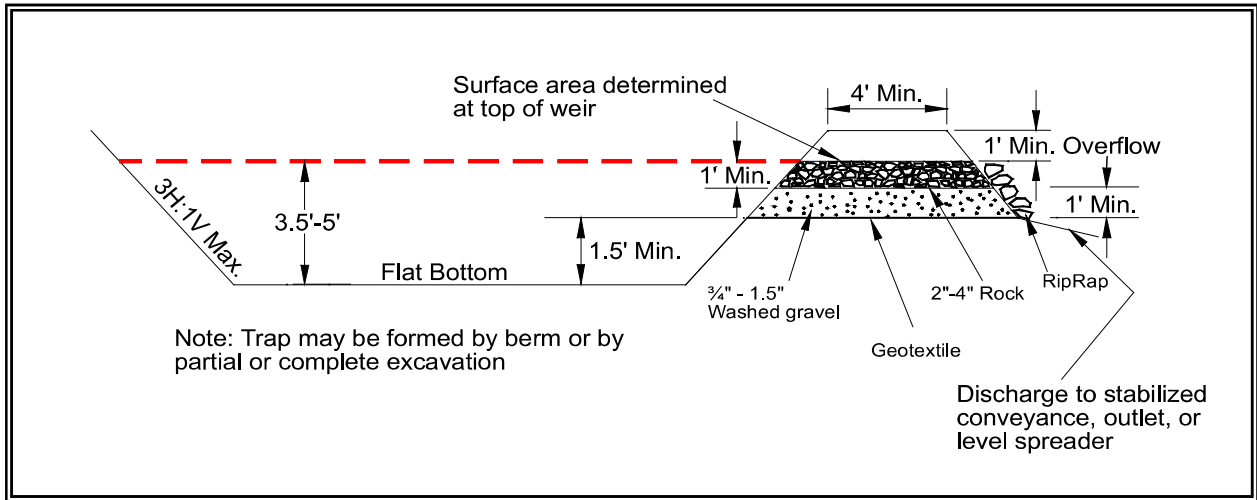

**Figure 4.2.16 – Cross Section of Sediment Trap**

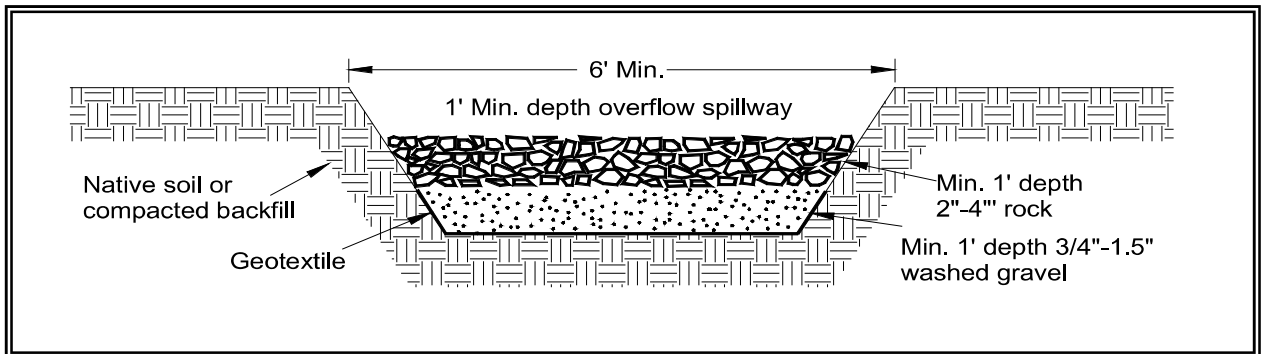

**Figure 4.2.17 – Sediment Trap Outlet**

## **BMP C241: Temporary Sediment Pond**

### ***Purpose***

Sediment ponds remove sediment from runoff originating from disturbed areas of the site. Sediment ponds are typically designed to remove sediment no smaller than medium silt (0.02 mm). Consequently, they usually reduce turbidity only slightly.

### ***Conditions of Use***

Prior to leaving a construction site, stormwater runoff must pass through a sediment pond or other appropriate sediment removal best management practice.

A sediment pond shall be used where the contributing drainage area is 3 acres or more. Ponds must be used in conjunction with erosion control practices to reduce the amount of sediment flowing into the basin.

### ***Design and Installation Specifications***

- Sediment basins must be installed only on sites where failure of the structure would not result in loss of life, damage to homes or buildings, or interruption of use or service of public roads or utilities. Also, sediment traps and ponds are attractive to children and can be very dangerous. Compliance with local ordinances regarding health and safety must be addressed. If fencing of the pond is required, the type of fence and its location shall be shown on the ESC plan.
- Structures having a maximum storage capacity at the top of the dam of 10 acre-ft (435,600 ft<sup>3</sup>) or more are subject to the Washington Dam Safety Regulations ([Chapter 173-175 WAC](#)).
- See [Figures 4.2.18](#), [4.2.19](#), and [4.2.20](#) for details.
- If permanent runoff control facilities are part of the project, they should be used for sediment retention. The surface area requirements of the sediment basin must be met. This may require temporarily enlarging the permanent basin to comply with the surface area requirements. The permanent control structure must be temporarily replaced with a control structure that only allows water to leave the pond from the surface or by pumping. The permanent control structure must be installed after the site is fully stabilized. .
- Use of infiltration facilities for sedimentation basins during construction tends to clog the soils and reduce their capacity to infiltrate. If infiltration facilities are to be used, the sides and bottom of the facility must only be rough excavated to a minimum of 2 feet above final grade. Final grading of the infiltration facility shall occur only when all contributing drainage areas are fully stabilized. The infiltration pretreatment facility should be fully constructed and used with the sedimentation basin to help prevent clogging.
- Determining Pond Geometry  
Obtain the discharge from the hydrologic calculations of the peak flow for the 2-year runoff event ( $Q_2$ ). The 10-year peak flow shall be used if

the project size, expected timing and duration of construction, or downstream conditions warrant a higher level of protection. If no hydrologic analysis is required, the Rational Method may be used.

Determine the required surface area at the top of the riser pipe with the equation:

$$SA = 2 \times Q_2 / 0.00096 \quad \text{or} \\ 2080 \text{ square feet per cfs of inflow}$$

See [BMP C240](#) for more information on the derivation of the surface area calculation.

The basic geometry of the pond can now be determined using the following design criteria:

- Required surface area SA (from Step 2 above) at top of riser.
- Minimum 3.5-foot depth from top of riser to bottom of pond.
- Maximum 3H:1V interior side slopes and maximum 2H:1V exterior slopes. The interior slopes can be increased to a maximum of 2H:1V if fencing is provided at or above the maximum water surface.
- One foot of freeboard between the top of the riser and the crest of the emergency spillway.
- Flat bottom.
- Minimum 1-foot deep spillway.
- Length-to-width ratio between 3:1 and 6:1.
- Sizing of Discharge Mechanisms.

The outlet for the basin consists of a combination of principal and emergency spillways. These outlets must pass the peak runoff expected from the contributing drainage area for a 100-year storm. If, due to site conditions and basin geometry, a separate emergency spillway is not feasible, the principal spillway must pass the entire peak runoff expected from the 100-year storm. However, an attempt to provide a separate emergency spillway should always be made. The runoff calculations should be based on the site conditions during construction. The flow through the dewatering orifice cannot be utilized when calculating the 100-year storm elevation because of its potential to become clogged; therefore, available spillway storage must begin at the principal spillway riser crest.

The principal spillway designed by the procedures contained in this standard will result in some reduction in the peak rate of runoff. However, the riser outlet design will not adequately control the basin discharge to the predevelopment discharge limitations as stated in Minimum Requirement #7: Flow Control. However, if the basin for a permanent stormwater detention pond is used for a temporary

sedimentation basin, the control structure for the permanent pond can be used to maintain predevelopment discharge limitations. The size of the basin, the expected life of the construction project, the anticipated downstream effects and the anticipated weather conditions during construction, should be considered to determine the need of additional discharge control. See [Figure 4.2.21](#) for riser inflow curves.

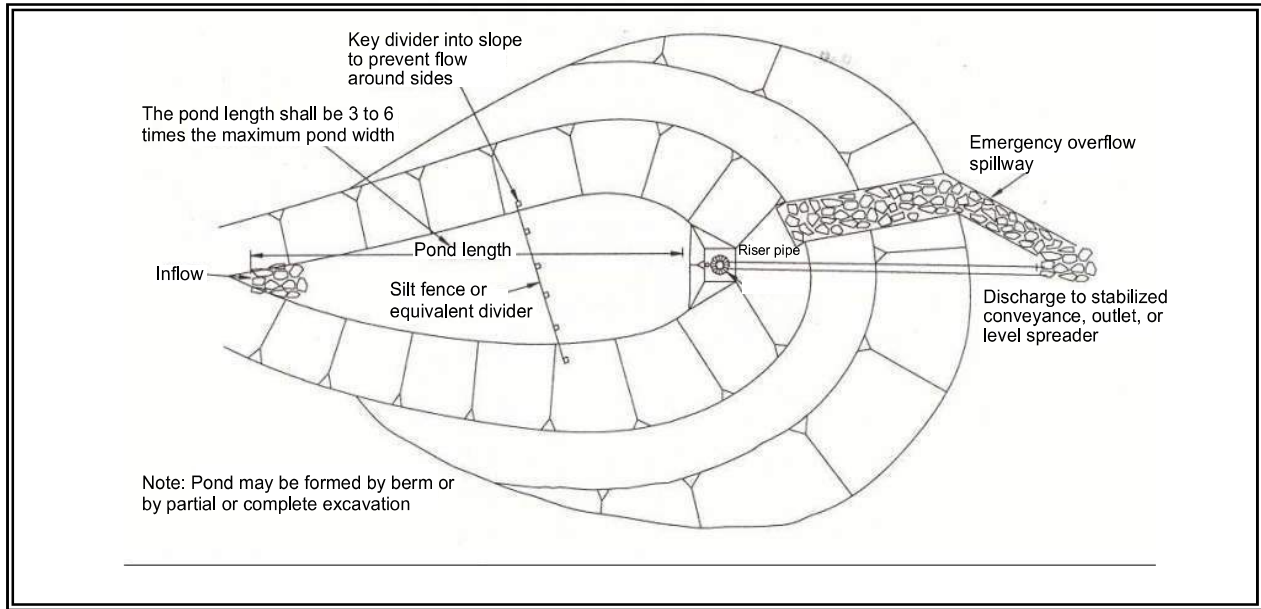

**Figure 4.2.18 – Sediment Pond Plan View**

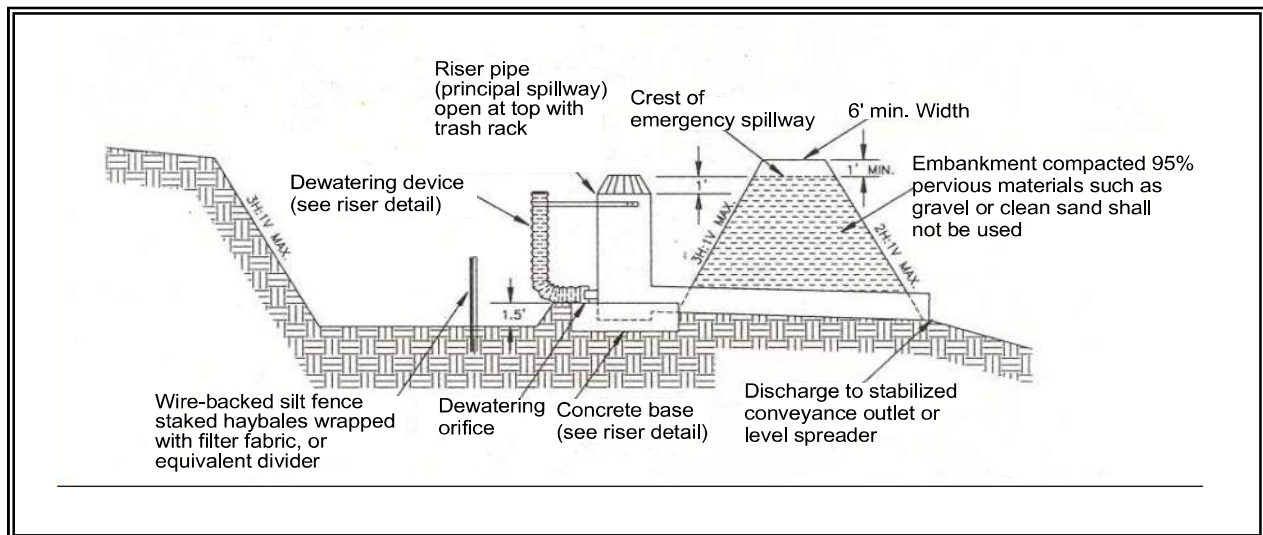

**Figure 4.2.19 – Sediment Pond Cross Section**





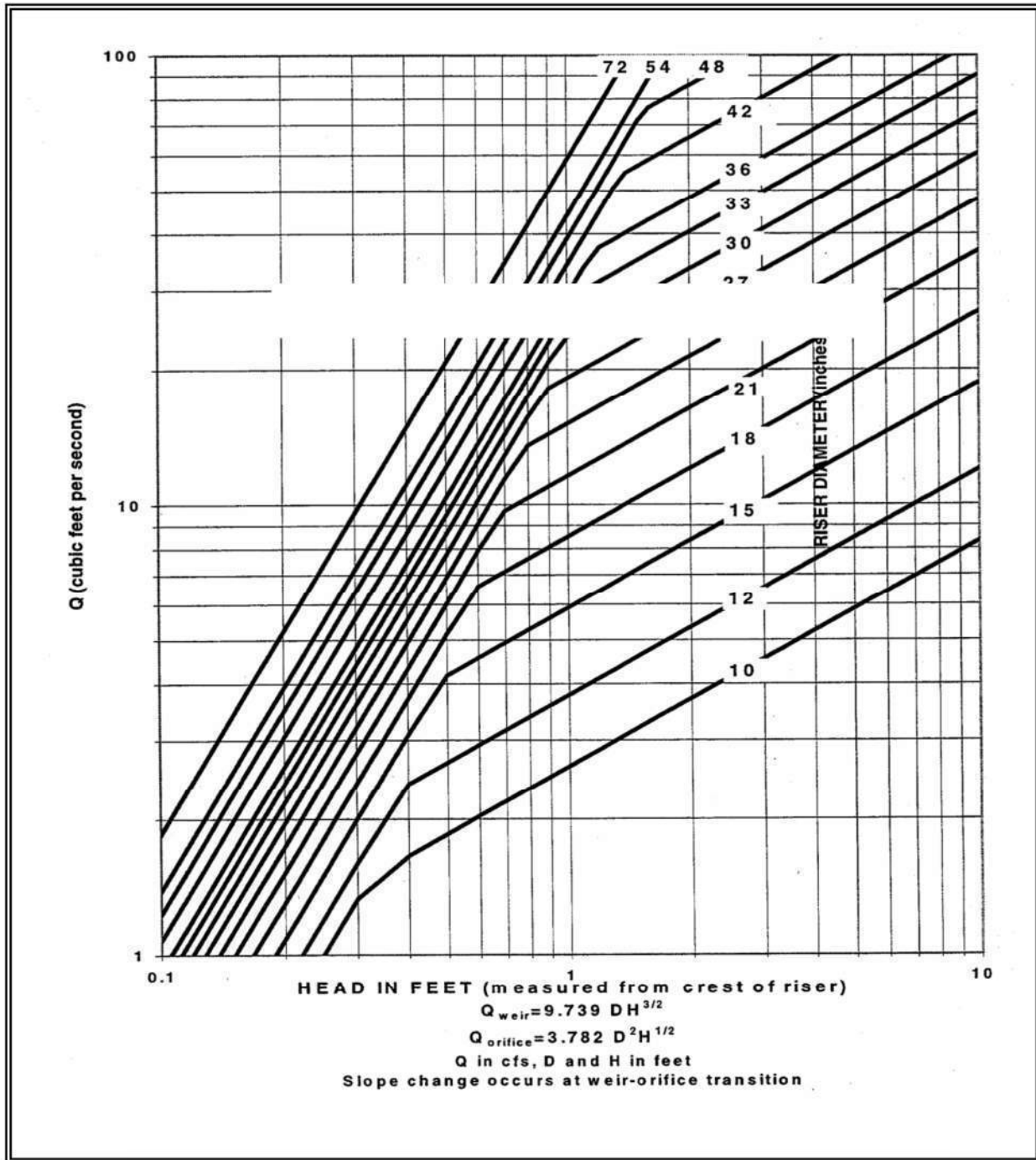

Figure 4.2.21 – Riser Inflow Curves

**Principal Spillway:** Determine the required diameter for the principal spillway (riser pipe). The diameter shall be the minimum necessary to pass the site's 15-minute, 10-year flowrate. If using the Western Washington Hydrology Model (WWHM), Version 2 or 3, design flow is the 10-year (1 hour) flow for the developed (unmitigated) site, multiplied by a factor of 1.6. Use Figure 4.2.21 to determine this diameter ( $h = 1$ -foot). *Note: A permanent control structure may be used instead of a temporary riser.*

**Emergency Overflow Spillway:** Determine the required size and design of the emergency overflow spillway for the developed 100-year peak flow using the method contained in Volume III.

**Dewatering Orifice:** Determine the size of the dewatering orifice(s) (minimum 1-inch diameter) using a modified version of the discharge equation for a vertical orifice and a basic equation for the area of a circular orifice. Determine the required area of the orifice with the following equation:

$$A_o = \frac{A_s (2h)^{0.5}}{0.6 \times 3600 T g^{0.5}}$$

where  $A_o$  = orifice area (square feet)  
 $A_s$  = pond surface area (square feet)  
 $h$  = head of water above orifice (height of riser in feet)  
 $T$  = dewatering time (24 hours)  
 $g$  = acceleration of gravity (32.2 feet/second<sup>2</sup>)

Convert the required surface area to the required diameter  $D$  of the orifice:

$$D = 24 \times \sqrt{\frac{A_o}{\pi}} = 13.54 \times \sqrt{A_o}$$

The vertical, perforated tubing connected to the dewatering orifice must be at least 2 inches larger in diameter than the orifice to improve flow characteristics. The size and number of perforations in the tubing should be large enough so that the tubing does not restrict flow. The orifice should control the flow rate.

- **Additional Design Specifications**

The pond shall be divided into two roughly equal volume cells by a permeable divider that will reduce turbulence while allowing movement of water between cells. The divider shall be at least one-half the height of the riser and a minimum of one foot below the top of the riser. Wire-backed, 2- to 3-foot high, extra strength filter fabric supported by treated 4"x4"s can be used as a divider. Alternatively, staked straw bales wrapped with filter fabric (geotextile) may be used. If the pond is more than 6 feet deep, a different mechanism must be proposed. A riprap embankment is one acceptable method of

separation for deeper ponds. Other designs that satisfy the intent of this provision are allowed as long as the divider is permeable, structurally sound, and designed to prevent erosion under or around the barrier.

To aid in determining sediment depth, one-foot intervals shall be prominently marked on the riser.

If an embankment of more than 6 feet is proposed, the pond must comply with the criteria contained in Volume III regarding dam safety for detention BMPs.

- The most common structural failure of sedimentation basins is caused by piping. Piping refers to two phenomena: (1) water seeping through fine-grained soil, eroding the soil grain by grain and forming pipes or tunnels; and, (2) water under pressure flowing upward through a granular soil with a head of sufficient magnitude to cause soil grains to lose contact and capability for support.

The most critical construction sequences to prevent piping will be:

1. Tight connections between riser and barrel and other pipe connections.
2. Adequate anchoring of riser.
3. Proper soil compaction of the embankment and riser footing.
4. Proper construction of anti-seep devices.

***Maintenance Standards***

- Sediment shall be removed from the pond when it reaches 1-foot in depth.
- Any damage to the pond embankments or slopes shall be repaired.

**BMP C250: Construction Stormwater Chemical Treatment**

***Purpose***

This BMP applies when using stormwater chemicals in batch treatment or flow-through treatment.

Turbidity is difficult to control once fine particles are suspended in stormwater runoff from a construction site. Sedimentation ponds are effective at removing larger particulate matter by gravity settling, but are ineffective at removing smaller particulates such as clay and fine silt. Traditional erosion and sediment control BMPs may not be adequate to ensure compliance with the water quality standards for turbidity in receiving water.

Chemical treatment can reliably provide exceptional reductions of turbidity and associated pollutants. Chemical treatment may be required to meet turbidity stormwater discharge requirements, especially when construction is to proceed through the wet season.

***Conditions of Use***

Formal written approval from Ecology is required for the use of chemical treatment regardless of site size. The Local Permitting Authority may also

***Design and  
Installation  
Specifications***

require review and approval. When approved, the chemical treatment systems must be included in the Construction Stormwater Pollution Prevention Plan (SWPPP).

See [Appendix II-B](#) for background information on chemical treatment.

**Criteria for Chemical Treatment Product Use:** Chemically treated stormwater discharged from construction sites must be nontoxic to aquatic organisms. The Chemical Technology Assessment Protocol (CTAPE) must be used to evaluate chemicals proposed for stormwater treatment. Only chemicals approved by Ecology under the CTAPE may be used for stormwater treatment. The approved chemicals, their allowable application techniques (batch treatment or flow-through treatment), allowable application rates, and conditions of use can be found at the Department of Ecology Emerging Technologies website: <http://www.ecy.wa.gov/programs/wq/stormwater/newtech/technologies.html>.

**Treatment System Design Considerations:** The design and operation of a chemical treatment system should take into consideration the factors that determine optimum, cost-effective performance. It is important to recognize the following:

- Only Ecology approved chemicals may be used and must follow approved dose rate.
- The pH of the stormwater must be in the proper range for the polymers to be effective, which is typically 6.5 to 8.5
- The coagulant must be mixed rapidly into the water to ensure proper dispersion.
- A flocculation step is important to increase the rate of settling, to produce the lowest turbidity, and to keep the dosage rate as low as possible.
- Too little energy input into the water during the flocculation phase results in flocs that are too small and/or insufficiently dense. Too much energy can rapidly destroy floc as it is formed.
- Care must be taken in the design of the withdrawal system to minimize outflow velocities and to prevent floc discharge. Discharge from a batch treatment system should be directed through a physical filter such as a vegetated swale that would catch any unintended floc discharge. Currently, flow-through systems always discharge through the chemically enhanced sand filtration system.
- System discharge rates must take into account downstream conveyance integrity.

### **Polymer Batch Treatment Process Description:**

A batch chemical treatment system consists of the stormwater collection system (either temporary diversion or the permanent site drainage system), a storage pond, pumps, a chemical feed system, treatment cells, and interconnecting piping.

The batch treatment system shall use a minimum of two lined treatment cells in addition to an untreated stormwater storage pond. Multiple treatment cells allow for clarification of treated water while other cells are being filled or emptied. Treatment cells may be ponds or tanks. Ponds with constructed earthen embankments greater than six feet high or which impound more than 10 acre-feet require special engineering analyses. The Ecology Dam Safety Section has specific design criteria for dams in Washington State (see <http://www.ecy.wa.gov/programs/wr/dams/GuidanceDocs.html> ).

Stormwater is collected at interception point(s) on the site and is diverted by gravity or by pumping to an untreated stormwater storage pond or other untreated stormwater holding area. The stormwater is stored until treatment occurs. It is important that the holding pond be large enough to provide adequate storage.

The first step in the treatment sequence is to check the pH of the stormwater in the untreated stormwater storage pond. The pH is adjusted by the application of carbon dioxide or a base until the stormwater in the storage pond is within the desired pH range, 6.5 to 8.5. When used, carbon dioxide is added immediately downstream of the transfer pump. Typically sodium bicarbonate (baking soda) is used as a base, although other bases may be used. When needed, base is added directly to the untreated stormwater storage pond. The stormwater is recirculated with the treatment pump to provide mixing in the storage pond. Initial pH adjustments should be based on daily bench tests. Further pH adjustments can be made at any point in the process.

Once the stormwater is within the desired pH range (dependant on polymer being used), the stormwater is pumped from the untreated stormwater storage pond to a treatment cell as polymer is added. The polymer is added upstream of the pump to facilitate rapid mixing.

After polymer addition, the water is kept in a lined treatment cell for clarification of the sediment-floc. In a batch mode process, clarification typically takes from 30 minutes to several hours. Prior to discharge samples are withdrawn for analysis of pH, flocculent chemical concentration, and turbidity. If both are acceptable, the treated water is discharged.

Several configurations have been developed to withdraw treated water from the treatment cell. The original configuration is a device that withdraws the treated water from just beneath the water surface using a

float with adjustable struts that prevent the float from settling on the cell bottom. This reduces the possibility of picking up sediment-floc from the bottom of the pond. The struts are usually set at a minimum clearance of about 12 inches; that is, the float will come within 12 inches of the bottom of the cell. Other systems have used vertical guides or cables which constrain the float, allowing it to drift up and down with the water level. More recent designs have an H-shaped array of pipes, set on the horizontal.

This scheme provides for withdrawal from four points rather than one. This configuration reduces the likelihood of sucking settled solids from the bottom. It also reduces the tendency for a vortex to form. Inlet diffusers, a long floating or fixed pipe with many small holes in it, are also an option.

Safety is a primary concern. Design should consider the hazards associated with operations, such as sampling. Facilities should be designed to reduce slip hazards and drowning. Tanks and ponds should have life rings, ladders, or steps extending from the bottom to the top.

#### **Polymer Batch Treatment Process Description:**

At a minimum, a flow-through chemical treatment system consists of the stormwater collection system (either temporary diversion or the permanent site drainage system), an untreated stormwater storage pond, and the chemically enhanced sand filtration system.

Stormwater is collected at interception point(s) on the site and is diverted by gravity or by pumping to an untreated stormwater storage pond or other untreated stormwater holding area. The stormwater is stored until treatment occurs. It is important that the holding pond be large enough to provide adequate storage.

Stormwater is then pumped from the untreated stormwater storage pond to the chemically enhanced sand filtration system where polymer is added. Adjustments to pH may be necessary before chemical addition. The sand filtration system continually monitors the stormwater for turbidity and pH. If the discharge water is ever out of an acceptable range for turbidity or pH, the water is recycled to the untreated stormwater pond where it can be retreated.

***For batch treatment and flow-through treatment,*** the following equipment should be located in a lockable shed:

- The chemical injector.
- Secondary containment for acid, caustic, buffering compound, and treatment chemical.
- Emergency shower and eyewash.
- Monitoring equipment which consists of a pH meter and a turbidimeter.

### **System Sizing:**

Certain sites are required to implement flow control for the developed sites. These sites must also control stormwater release rates during construction. Generally, these are sites that discharge stormwater directly, or indirectly, through a conveyance system, into a fresh water. System sizing is dependent on flow control requirements.

### **Sizing Criteria for Batch Treatment Systems for Flow Control Exempt Water Bodies:**

The total volume of the untreated stormwater storage pond and treatment ponds or tanks must be large enough to treat stormwater that is produced during multiple day storm events. It is recommended that at a minimum the untreated stormwater storage pond be sized to hold 1.5 times the runoff volume of the 10-year, 24-hour storm event. Bypass should be provided around the chemical treatment system to accommodate extreme storm events. Runoff volume shall be calculated using the methods presented in Volume 3, Chapter 2. Worst-case land cover conditions (i.e., producing the most runoff) should be used for analyses (in most cases, this would be the land cover conditions just prior to final landscaping).

Primary settling should be encouraged in the untreated stormwater storage pond. A forebay with access for maintenance may be beneficial.

There are two opposing considerations in sizing the treatment cells. A larger cell is able to treat a larger volume of water each time a batch is processed. However, the larger the cell the longer the time required to empty the cell. A larger cell may also be less effective at flocculation and therefore require a longer settling time. The simplest approach to sizing the treatment cell is to multiply the allowable discharge flow rate times the desired drawdown time. A 4-hour drawdown time allows one batch per cell per 8-hour work period, given 1 hour of flocculation followed by two hours of settling.

If the discharge is directly to a flow control exempt receiving water listed in Appendix I-E of Volume I or to an infiltration system, there is no discharge flow limit.

Ponds sized for flow control water bodies must at a minimum meet the sizing criteria for flow control exempt waters.

### **Sizing Criteria for Flow-Through Treatment Systems for Flow Control Exempt Water Bodies:**

When sizing storage ponds or tanks for flow-through systems for flow control exempt water bodies, the treatment system capacity should be a factor. The untreated stormwater storage pond or tank should be sized to hold 1.5 times the runoff volume of the 10-year, 24-hour storm event minus the treatment system flowrate for an 8-hour period. For a chitosan-enhanced sand filtration system, the treatment system flowrate should be sized using a hydraulic loading rate between 6-8 gpm/ft<sup>2</sup>. Other hydraulic

loading rates may be more appropriate for other systems. Bypass should be provided around the chemical treatment system to accommodate extreme storms. Runoff volume shall be calculated using the methods presented in Volume 3, Chapter 2. Worst-case land cover conditions (i.e., producing the most runoff) should be used for analyses (in most cases, this would be the land cover conditions just prior to final landscaping).

#### **Sizing Criteria for Flow Control Water Bodies:**

Sites that must implement flow control for the developed site condition must also control stormwater release rates during construction. Construction site stormwater discharges shall not exceed the discharge durations of the pre-developed condition for the range of pre-developed discharge rates from ½ of the 2-year flow through the 10-year flow as predicted by an approved continuous runoff model. The pre-developed condition to be matched shall be the land cover condition immediately prior to the development project. This restriction on release rates can affect the size of the storage pond and treatment cells.

The following is how WWHM can be used to determine the release rates from the chemical treatment systems:

1. Determine the pre-developed flow durations to be matched by entering the existing land use area under the “Pre-developed” scenario in WWHM. The default flow range is from ½ of the 2-year flow through the 10-year flow.
2. Enter the post developed land use area in the “Developed Unmitigated” scenario in WWHM.
3. Copy the land use information from the “Developed Unmitigated” to “Developed Mitigated” scenario.
4. While in the “Developed Mitigated” scenario, add a pond element under the basin element containing the post-developed land use areas. This pond element represents information on the available untreated stormwater storage and discharge from the chemical treatment system. In cases where the discharge from the chemical treatment system is controlled by a pump, a stage/storage/discharge (SSD) table representing the pond must be generated outside WWHM and imported into WWHM. WWHM can route the runoff from the post-developed condition through this SSD table (the pond) and determine compliance with the flow duration standard. This would be an iterative design procedure where if the initial SSD table proved to be inadequate, the designer would have to modify the SSD table outside WWHM and re-import in WWHM and route the runoff through it again. The iteration will continue until a pond that complies with the flow duration standard is correctly sized.

Notes on SSD table characteristics:



- The pump discharge rate would likely be initially set at just below  $\frac{1}{2}$  of the 2-year flow from the pre-developed condition. As runoff coming into the untreated stormwater storage pond increases and the available untreated stormwater storage volume gets used up, it would be necessary to increase the pump discharge rate above  $\frac{1}{2}$  of the 2-year. The increase(s) above  $\frac{1}{2}$  of the 2-year must be such that they provide some relief to the untreated stormwater storage needs but at the same time will not cause violations of the flow duration standard at the higher flows. The final design SSD table will identify the appropriate pumping rates and the corresponding stage and storages.
  - When building such a flow control system, the design must ensure that any automatic adjustments to the pumping rates will be as a result of changes to the available storage in accordance with the final design SSD table.
5. It should be noted that the above procedures would be used to meet the flow control requirements. The chemical treatment system must be able to meet the runoff treatment requirements. It is likely that the discharge flow rate of  $\frac{1}{2}$  of the 2-year or more may exceed the treatment capacity of the system. If that is the case, the untreated stormwater discharge rate(s) (i.e., influent to the treatment system) must be reduced to allow proper treatment. Any reduction in the flows would likely result in the need for a larger untreated stormwater storage volume.

If the discharge is to a municipal storm drainage system, the allowable discharge rate may be limited by the capacity of the public system. It may be necessary to clean the municipal storm drainage system prior to the start of the discharge to prevent scouring solids from the drainage system. If the municipal storm drainage system discharges to a water body not on the flow control exempt list, the project site is subject to flow control requirements. Obtain permission from the owner of the collection system before discharging to it.

If system design does not allow you to discharge at the slower rates as described above and if the site has a retention or detention pond that will serve the planned development, the discharge from the treatment system may be directed to the permanent retention/detention pond to comply with the flow control requirement. In this case, the untreated stormwater storage pond and treatment system will be sized according to the sizing criteria for flow-through treatment systems for flow control exempt water bodies described earlier except all discharge (water passing through the treatment system and stormwater bypassing the treatment system) will be directed into the permanent retention/detention pond. If site constraints make locating the untreated stormwater storage pond difficult, the permanent retention/detention pond may be divided to serve as the untreated stormwater storage pond and the post-treatment flow control pond. A berm or barrier must be used in this case so the untreated water does not mix with the treated

## ***Maintenance Standards***

water. Both untreated stormwater storage requirements, and adequate post-treatment flow control must be achieved. The post-treatment flow control pond's revised dimensions must be entered into the WWHM and the WWHM must be run to confirm compliance with the flow control requirement.

**Monitoring:** At a minimum, the following monitoring shall be conducted. Test results shall be recorded on a daily log kept on site. Additional testing may be required by the NPDES permit based on site conditions.

### Operational Monitoring:

- Total volume treated and discharged.
- Flow must be continuously monitored and recorded at not greater than 15-minute intervals.
- Type and amount of chemical used for pH adjustment.
- Amount of polymer used for treatment.
- Settling time.

### Compliance Monitoring:

- Influent and effluent pH, flocculent chemical concentration, and turbidity must be continuously monitored and recorded at not greater than 15-minute intervals. pH and turbidity of the receiving water.

### Biomonitoring:

Treated stormwater must be non-toxic to aquatic organisms. Treated stormwater must be tested for aquatic toxicity or residual chemicals. Frequency of biomonitoring will be determined by Ecology.

Residual chemical tests must be approved by Ecology prior to their use.

If testing treated stormwater for aquatic toxicity, you must test for acute (lethal) toxicity. Bioassays shall be conducted by a laboratory accredited by Ecology, unless otherwise approved by Ecology. Acute toxicity tests shall be conducted per the CTAPE protocol.

**Discharge Compliance: Prior to discharge, treated stormwater must be sampled and tested for compliance with pH, flocculent chemical concentration, and turbidity limits.** These limits may be established by the Construction Stormwater General Permit or a site-specific discharge permit. Sampling and testing for other pollutants may also be necessary at some sites. pH must be within the range of 6.5 to 8.5 standard units and not cause a change in the pH of the receiving water of more than 0.2 standard units. Treated stormwater samples and measurements shall be taken from the discharge pipe or another location representative of the nature of the treated stormwater discharge. Samples used for determining compliance with the water quality standards in the receiving water shall not be taken from the treatment pond prior to decanting. Compliance with the water quality standards is determined in the receiving water.

**Operator Training:** Each contractor who intends to use chemical treatment shall be trained by an experienced contractor . Each site using chemical treatment must have an operator trained and certified by an organization approved by Ecology.

**Standard BMPs:** Surface stabilization BMPs should be implemented on site to prevent significant erosion. All sites shall use a truck wheel wash to prevent tracking of sediment off site.

**Sediment Removal and Disposal:**

- Sediment shall be removed from the storage or treatment cells as necessary. Typically, sediment removal is required at least once during a wet season and at the decommissioning of the cells. Sediment remaining in the cells between batches may enhance the settling process and reduce the required chemical dosage.
- Sediment that is known to be non-toxic may be incorporated into the site away from drainages.

**BMP C251: Construction Stormwater Filtration**

*Purpose*

Filtration removes sediment from runoff originating from disturbed areas of the site.

*Background Information:*

Filtration with sand media has been used for over a century to treat water and wastewater. The use of sand filtration for treatment of stormwater has developed recently, generally to treat runoff from streets, parking lots, and residential areas. The application of filtration to construction stormwater treatment is currently under development.

*Conditions of Use*

Traditional BMPs used to control soil erosion and sediment loss from sites under development may not be adequate to ensure compliance with the water quality standard for turbidity in the receiving water. Filtration may be used in conjunction with gravity settling to remove sediment as small as fine silt (0.5 µm). The reduction in turbidity will be dependent on the particle size distribution of the sediment in the stormwater. In some circumstances, sedimentation and filtration may achieve compliance with the water quality standard for turbidity.

The use of construction stormwater filtration does not require approval from Ecology as long as treatment chemicals are not used. Filtration in conjunction with polymer treatment requires testing under the Chemical Technology Assessment Protocol – Ecology (CTAPE) before it can be initiated. Approval from the appropriate regional Ecology office must be obtained at each site where polymers use is proposed prior to use. For more guidance on stormwater chemical treatment see [BMP C250](#).

***Design and  
Installation  
Specifications***

Two types of filtration systems may be applied to construction stormwater treatment: rapid and slow. Rapid sand filters are the typical system used for water and wastewater treatment. They can achieve relatively high hydraulic flow rates, on the order of 2 to 20 gpm/sf, because they have automatic backwash systems to remove accumulated solids. In contrast, slow sand filters have very low hydraulic rates, on the order of 0.02 gpm/sf, because they do not have backwash systems. Slow sand filtration has generally been used to treat stormwater. Slow sand filtration is mechanically simple in comparison to rapid sand filtration but requires a much larger filter area.

**Filtration Equipment.** Sand media filters are available with automatic backwashing features that can filter to 50  $\mu\text{m}$  particle size. Screen or bag filters can filter down to 5  $\mu\text{m}$ . Fiber wound filters can remove particles down to 0.5  $\mu\text{m}$ . Filters should be sequenced from the largest to the smallest pore opening. Sediment removal efficiency will be related to particle size distribution in the stormwater.

**Treatment Process Description.** Stormwater is collected at interception point(s) on the site and is diverted to an untreated stormwater sediment pond or tank for removal of large sediment and storage of the stormwater before it is treated by the filtration system. The untreated stormwater is pumped from the trap, pond, or tank through the filtration system in a rapid sand filtration system. Slow sand filtration systems are designed as flow through systems using gravity.

***Maintenance  
Standards***

Rapid sand filters typically have automatic backwash systems that are triggered by a pre-set pressure drop across the filter. If the backwash water volume is not large or substantially more turbid than the untreated stormwater stored in the holding pond or tank, backwash return to the untreated stormwater pond or tank may be appropriate. However, other means of treatment and disposal may be necessary.

- Screen, bag, and fiber filters must be cleaned and/or replaced when they become clogged.
- Sediment shall be removed from the storage and/or treatment ponds as necessary. Typically, sediment removal is required once or twice during a wet season and at the decommissioning of the ponds.

**Sizing Criteria for Flow-Through Treatment Systems for Flow Control Exempt Water Bodies:**

When sizing storage ponds or tanks for flow-through systems for flow control exempt water bodies the treatment system capacity should be a factor. The untreated stormwater storage pond or tank should be sized to hold 1.5 times the runoff volume of the 10-year, 24-hour storm event minus the treatment system flowrate for an 8-hour period. For a chitosan-enhanced sand filtration system, the treatment system flowrate should be sized using a hydraulic loading rate between 6-8 gpm/ft<sup>2</sup>. Other hydraulic

loading rates may be more appropriate for other systems. Bypass should be provided around the chemical treatment system to accommodate extreme storms. Runoff volume shall be calculated using the methods presented in Volume 3, Chapter 2. Worst-case conditions (i.e., producing the most runoff) should be used for analyses (most likely conditions present prior to final landscaping).

### **Sizing Criteria for Flow Control Water Bodies:**

Sites that must implement flow control for the developed site condition must also control stormwater release rates during construction. Construction site stormwater discharges shall not exceed the discharge durations of the pre-developed condition for the range of pre-developed discharge rates from 1/2 of the 2-year flow through the 10-year flow as predicted by an approved continuous runoff model. The pre-developed condition to be matched shall be the land cover condition immediately prior to the development project. This restriction on release rates can affect the size of the storage pond, the filtration system, and the flow rate through the filter system.

The following is how WWHM can be used to determine the release rates from the filtration systems:

1. Determine the pre-developed flow durations to be matched by entering the land use area under the “Pre-developed” scenario in WWHM. The default flow range is from 1/2 of the 2-year flow through the 10-year flow.
2. Enter the post developed land use area in the “Developed Unmitigated” scenario in WWHM.
3. Copy the land use information from the “Developed Unmitigated” to “Developed Mitigated” scenario.
4. There are two possible ways to model stormwater filtration systems:
  - a. The stormwater filtration system uses an untreated stormwater storage pond/tank and the discharge from this pond/tank is pumped to one or more filters. In-line filtration chemicals would be added to the flow right after the pond/tank and before the filter(s). Because the discharge is pumped, WWHM can't generate a stage/storage /discharge (SSD) table for this system. This system is modeled the same way as described in [BMP C250](#) and is as follows:

While in the “Developed Mitigated” scenario, add a pond element under the basin element containing the post-developed land use areas. This pond element represents information on the available untreated stormwater storage and discharge from the filtration system. In cases where the discharge from the filtration system is controlled by a pump, a stage/storage/discharge (SSD) table representing the pond must be generated outside WWHM and

imported into WWHM. WWHM can route the runoff from the post-developed condition through this SSD table (the pond) and determine compliance with the flow duration standard. This would be an iterative design procedure where if the initial SSD table proved to be out of compliance, the designer would have to modify the SSD table outside WWHM and re-import in WWHM and route the runoff through it again. The iteration will continue until a pond that enables compliance with the flow duration standard is designed.

Notes on SSD table characteristics:

- The pump discharge rate would likely be initially set at just below  $\frac{1}{2}$  if the 2-year flow from the pre-developed condition. As runoff coming into the untreated stormwater storage pond increases and the available untreated stormwater storage volume gets used up, it would be necessary to increase the pump discharge rate above  $\frac{1}{2}$  of the 2-year. The increase(s) above  $\frac{1}{2}$  of the 2-year must be such that they provide some relief to the untreated stormwater storage needs but at the same time they will not cause violations of the flow duration standard at the higher flows. The final design SSD table will identify the appropriate pumping rates and the corresponding stage and storages.
  - When building such a flow control system, the design must ensure that any automatic adjustments to the pumping rates will be as a result of changes to the available storage in accordance with the final design SSD table.
- b. The stormwater filtration system uses a storage pond/tank and the discharge from this pond/tank gravity flows to the filter. This is usually a slow sand filter system and it is possible to model it in WWHM as a Filter element or as a combination of Pond and Filter element placed in series. The stage/storage/discharge table(s) may then be generated within WWHM as follows:
- (i) While in the “Developed Mitigated” scenario, add a Filter element under the basin element containing the post-developed land use areas. The length and width of this filter element would have to be the same as the bottom length and width of the upstream untreated stormwater storage pond/tank.
  - (ii) In cases where the length and width of the filter is not the same as those for the bottom of the upstream untreated stormwater storage tank/pond, the treatment system may be modeled as a Pond element followed by a Filter element. By having these two elements, WWHM would then generate a SSD table for the storage pond which then gravity flows to the Filter element. The Filter element downstream of the untreated stormwater

storage pond would have a storage component through the media, and an overflow component for when the filtration capacity is exceeded.

WVHM can route the runoff from the post-developed condition through the treatment systems in 4b and determine compliance with the flow duration standard. This would be an iterative design procedure where if the initial sizing estimates for the treatment system proved to be inadequate, the designer would have to modify the system and route the runoff through it again. The iteration would continue until compliance with the flow duration standard is achieved.

5. It should be noted that the above procedures would be used to meet the flow control requirements. The filtration system must be able to meet the runoff treatment requirements. It is likely that the discharge flow rate of  $\frac{1}{2}$  of the 2-year or more may exceed the treatment capacity of the system. If that is the case, the untreated stormwater discharge rate(s) (i.e., influent to the treatment system) must be reduced to allow proper treatment. Any reduction in the flows would likely result in the need for a larger untreated stormwater storage volume.

If system design does not allow you to discharge at the slower rates as described above and if the site has a retention or detention pond that will serve the planned development, the discharge from the treatment system may be directed to the permanent retention/detention pond to comply with the flow control requirements. In this case, the untreated stormwater storage pond and treatment system will be sized according to the sizing criteria for flow-through treatment systems for flow control exempt waterbodies described earlier except all discharges (water passing through the treatment system and stormwater bypassing the treatment system) will be directed into the permanent retention/detention pond. If site constraints make locating the untreated stormwater storage pond difficult, the permanent retention/detention pond may be divided to serve as the untreated stormwater discharge pond and the post-treatment flow control pond. A berm or barrier must be used in this case so the untreated water does not mix with the treated water. Both untreated stormwater storage requirements, and adequate post-treatment flow control must be achieved. The post-treatment flow control pond's revised dimensions must be entered into the WVHM and the WVHM must be run to confirm compliance with the flow control requirement.

## **BMP C252: High pH Neutralization Using CO<sub>2</sub>**

### ***Purpose***

When pH levels in stormwater rise above 8.5 it is necessary to lower the pH levels to the acceptable range of 6.5 to 8.5, this process is called pH neutralization. pH neutralization involves the use of solid or compressed carbon dioxide gas in water requiring neutralization. Neutralized stormwater may be discharged to surface waters under the General Construction NPDES permit.

Neutralized process water such as concrete truck wash-out, hydro-demolition, or saw-cutting slurry must be managed to prevent discharge to surface waters. Any stormwater contaminated during concrete work is considered process wastewater and must not be discharged to surface waters.

### **Reason for pH Neutralization:**

A pH level range of 6.5 to 8.5 is typical for most natural watercourses, and this neutral pH is required for the survival of aquatic organisms. Should the pH rise or drop out of this range, fish and other aquatic organisms may become stressed and may die.

Calcium hardness can contribute to high pH values and cause toxicity that is associated with high pH conditions. A high level of calcium hardness in waters of the state is not allowed.

The water quality standard for pH in Washington State is in the range of 6.5 to 8.5. Ground water standard for calcium and other dissolved solids in Washington State is less than 500 mg/l.

### ***Conditions of Use***

#### **Causes of High pH:**

High pH at construction sites is most commonly caused by the contact of stormwater with poured or recycled concrete, cement, mortars, and other Portland cement or lime containing construction materials. (See [BMP C151: Concrete Handling](#) for more information on concrete handling procedures). The principal caustic agent in cement is calcium hydroxide (free lime).

#### **Advantages of CO<sub>2</sub> Sparging:**

- Rapidly neutralizes high pH water.
- Cost effective and safer to handle than acid compounds.
- CO<sub>2</sub> is self-buffering. It is difficult to overdose and create harmfully low pH levels.
- Material is readily available.



***Design and  
Installation  
Specifications***

**The Chemical Process:**

When carbon dioxide (CO<sub>2</sub>) is added to water (H<sub>2</sub>O), carbonic acid (H<sub>2</sub>CO<sub>3</sub>) is formed which can further dissociate into a proton (H<sup>+</sup>) and a bicarbonate anion (HCO<sub>3</sub><sup>-</sup>) as shown below:



The free proton is a weak acid that can lower the pH. Water temperature has an effect on the reaction as well. The colder the water temperature is the slower the reaction occurs and the warmer the water temperature is the quicker the reaction occurs. Most construction applications in Washington State have water temperatures in the 50°F or higher range so the reaction is almost simultaneous.

**Treatment Process:**

High pH water may be treated using continuous treatment, continuous discharge systems. These manufactured systems continuously monitor influent and effluent pH to ensure that pH values are within an acceptable range before being discharged. All systems must have fail safe automatic shut off switches in the event that pH is not within the acceptable discharge range. Only trained operators may operate manufactured systems. System manufacturers often provide trained operators or training on their devices.

The following procedure may be used when not using a continuous discharge system:

1. Prior to treatment, the appropriate jurisdiction should be notified in accordance with the regulations set by the jurisdiction.
2. Every effort should be made to isolate the potential high pH water in order to treat it separately from other stormwater on-site.
3. Water should be stored in an acceptable storage facility, detention pond, or containment cell prior to treatment.
4. Transfer water to be treated to the treatment structure. Ensure that treatment structure size is sufficient to hold the amount of water that is to be treated. Do not fill tank completely, allow at least 2 feet of freeboard.
5. The operator samples the water for pH and notes the clarity of the water. As a rule of thumb, less CO<sub>2</sub> is necessary for clearer water. This information should be recorded.
6. In the pH adjustment structure, add CO<sub>2</sub> until the pH falls in the range of 6.9-7.1. Remember that pH water quality standards apply so adjusting pH to within 0.2 pH units of receiving water (background pH) is recommended. It is unlikely that pH can be adjusted to within 0.2 pH units using dry ice. Compressed carbon dioxide gas should be introduced to the water using a carbon dioxide diffuser located near

the bottom of the tank, this will allow carbon dioxide to bubble up through the water and diffuse more evenly.

7. Slowly discharge the water making sure water does not get stirred up in the process. Release about 80% of the water from the structure leaving any sludge behind.
8. Discharge treated water through a pond or drainage system.
9. Excess sludge needs to be disposed of properly as concrete waste. If several batches of water are undergoing pH treatment, sludge can be left in treatment structure for the next batch treatment. Dispose of sludge when it fills 50% of tank volume.

Sites that must implement flow control for the developed site must also control stormwater release rates during construction. All treated stormwater must go through a flow control facility before being released to surface waters which require flow control.

### ***Maintenance Standards***

#### **Safety and Materials Handling:**

- All equipment should be handled in accordance with OSHA rules and regulations.
- Follow manufacturer guidelines for materials handling.

#### **Operator Records:**

Each operator should provide:

- A diagram of the monitoring and treatment equipment.
- A description of the pumping rates and capacity the treatment equipment is capable of treating.

Each operator should keep a written record of the following:

- Client name and phone number.
- Date of treatment.
- Weather conditions.
- Project name and location.
- Volume of water treated.
- pH of untreated water.
- Amount of CO<sub>2</sub> needed to adjust water to a pH range of 6.9-7.1.
- pH of treated water.
- Discharge point location and description.

A copy of this record should be given to the client/contractor who should retain the record for three years.

## Appendix C – Alternative BMPs

The following includes a list of possible alternative BMPs for each of the 14 elements not described in the main SWPPP text. This list can be referenced in the event a BMP for a specific element is not functioning as designed and an alternative BMP needs to be implemented.

### **Element #3 - Control Flow Rates**

BMP C235: Wattles

### **Element #4 - Install Sediment Controls**

BMP C231: Brush Barrier

BMP C232: Gravel Filter Berm

BMP C234: Vegetated Strip

BMP C235: Wattles

Advanced BMPs:

### **Element #5 - Stabilize Soils**

BMP C122: Nets and Blankets

BMP C124: Sodding

BMP C125: Topsoiling/Composting

BMP C126: Polyacrylamide for Soil Erosion Protecting

BMP C130: Surface Roughening

BMP C131: Gradient Terraces

### **Element #6 - Protect Slopes**

BMP C130: Surface Roughening

BMP C131: Gradient Terraces

BMP C203: Water Bars

BMP C204: Pipe Slope Drains

BMP C205: Subsurface Drains

BMP C206: Level Spreader

BMP C208: Triangular Silt Dike (Geotextile-Encased Check Dam)

### **Element #8 - Stabilize Channels and Outlets**

BMP C122: Nets and Blankets

### **Element #10 - Control Dewatering**

BMP C203: Water Bars

BMP C236: Vegetative Filtration

## **Appendix D – General Permit**

**To be added by contractor prior to construction.**

## Appendix E – Site Inspection Forms (and Site Log)

The results of each inspection shall be summarized in an inspection report or checklist that is entered into or attached to the site log book. It is suggested that the inspection report or checklist be included in this appendix to keep monitoring and inspection information in one document, but this is optional; however, it is mandatory that this SWPPP and the site inspection forms be kept onsite at all times during construction, and that inspections be performed and documented as outlined below.

At a minimum, each inspection report or checklist shall include:

- a. Inspection date/times
- b. Weather information: general conditions during inspection, approximate amount of precipitation since the last inspection, and approximate amount of precipitation within the last 24 hours.
- c. A summary or list of all BMPs that have been implemented, including observations of all erosion/sediment control structures or practices.
- d. The following shall be noted:
  - i. locations of BMPs inspected,
  - ii. locations of BMPs that need maintenance,
  - iii. the reason maintenance is needed,
  - iv. locations of BMPs that failed to operate as designed or intended, and
  - v. locations where additional or different BMPs are needed, and the reason(s) why
- e. A description of stormwater discharged from the site. The presence of suspended sediment, turbid water, discoloration, and/or oil sheen shall be noted, as applicable.
- f. A description of any water quality monitoring performed during inspection, and the results of that monitoring.
- g. General comments and notes, including a brief description of any BMP repairs, maintenance, or installations made as a result of the inspection.
- h. A statement that, in the judgment of the person conducting the site inspection, the site is either in compliance or out of compliance with the terms and conditions of the SWPPP and the NPDES permit. If the site inspection indicates that the site is out of compliance, the inspection report shall include a summary of the remedial actions required to bring the site back into compliance, as well as a schedule of implementation.
- i. Name, title, and signature of person conducting the site inspection; and the following statement: "I certify under penalty of law that this report is true, accurate, and complete, to the best of my knowledge and belief".

When the site inspection indicates that the site is not in compliance with any terms and conditions of the NPDES permit, the Permittee shall take immediate action(s) to: stop, contain, and clean up the unauthorized discharges, or otherwise stop the noncompliance; correct the

problem(s); implement appropriate Best Management Practices (BMPs), and/or conduct maintenance of existing BMPs; and achieve compliance with all applicable standards and permit conditions. In addition, if the noncompliance causes a threat to human health or the environment, the Permittee shall comply with the Noncompliance Notification requirements in Special Condition S5.F of the permit.

## Site Inspection Form

### General Information

<b>Project Name:</b>		<b>Title:</b>	
<b>Inspector Name:</b>		<b>CESCL # :</b>	
<b>Date:</b>		<b>Time:</b>	
<b>Inspection Type:</b>	<input type="checkbox"/> After a rain event <input type="checkbox"/> Weekly <input type="checkbox"/> Turbidity/transparency benchmark exceedance <input type="checkbox"/> Other		

### Weather

<b>Precipitation</b>	Since last inspection	In last 24 hours
<b>Description of General Site Conditions:</b>		

### Inspection of BMPs

#### *Element 1: Mark Clearing Limits*

BMP:

Location	Inspected		Functioning			Problem/Corrective Action
	Y	N	Y	N	NIP	

BMP:

Location	Inspected		Functioning			Problem/Corrective Action
	Y	N	Y	N	NIP	

#### *Element 2: Establish Construction Access*

BMP:

Location	Inspected		Functioning			Problem/Corrective Action
	Y	N	Y	N	NIP	

BMP:

Location	Inspected		Functioning			Problem/Corrective Action
	Y	N	Y	N	NIP	

**Element 3: Control Flow Rates**

BMP:

Location	Inspected		Functioning			Problem/Corrective Action
	Y	N	Y	N	NIP	

BMP:

Location	Inspected		Functioning			Problem/Corrective Action
	Y	N	Y	N	NIP	

**Element 4: Install Sediment Controls**

BMP:

Location	Inspected		Functioning			Problem/Corrective Action
	Y	N	Y	N	NIP	

BMP:

Location	Inspected		Functioning			Problem/Corrective Action
	Y	N	Y	N	NIP	

BMP:

Location	Inspected		Functioning			Problem/Corrective Action
	Y	N	Y	N	NIP	

BMP:

Location	Inspected		Functioning			Problem/Corrective Action
	Y	N	Y	N	NIP	

BMP:

Location	Inspected		Functioning			Problem/Corrective Action
	Y	N	Y	N	NIP	



**Element 5: Stabilize Soils**

BMP:

Location	Inspected		Functioning			Problem/Corrective Action
	Y	N	Y	N	NIP	

BMP:

Location	Inspected		Functioning			Problem/Corrective Action
	Y	N	Y	N	NIP	

BMP:

Location	Inspected		Functioning			Problem/Corrective Action
	Y	N	Y	N	NIP	

BMP:

Location	Inspected		Functioning			Problem/Corrective Action
	Y	N	Y	N	NIP	

**Element 6: Protect Slopes**

BMP:

Location	Inspected		Functioning			Problem/Corrective Action
	Y	N	Y	N	NIP	

BMP:

Location	Inspected		Functioning			Problem/Corrective Action
	Y	N	Y	N	NIP	

BMP:

Location	Inspected		Functioning			Problem/Corrective Action
	Y	N	Y	N	NIP	

**Element 7: Protect Drain Inlets**

BMP:

Location	Inspected		Functioning			Problem/Corrective Action
	Y	N	Y	N	NIP	

BMP:

Location	Inspected		Functioning			Problem/Corrective Action
	Y	N	Y	N	NIP	

BMP:

Location	Inspected		Functioning			Problem/Corrective Action
	Y	N	Y	N	NIP	

**Element 8: Stabilize Channels and Outlets**

BMP:

Location	Inspected		Functioning			Problem/Corrective Action
	Y	N	Y	N	NIP	

BMP:

Location	Inspected		Functioning			Problem/Corrective Action
	Y	N	Y	N	NIP	

BMP:

Location	Inspected		Functioning			Problem/Corrective Action
	Y	N	Y	N	NIP	

BMP:

Location	Inspected		Functioning			Problem/Corrective Action
	Y	N	Y	N	NIP	

**Element 9: Control Pollutants**

BMP:

Location	Inspected			Functioning			Problem/Corrective Action
	Y	N		Y	N	NIP	

BMP:

Location	Inspected			Functioning			Problem/Corrective Action
	Y	N		Y	N	NIP	

**Element 10: Control Dewatering**

BMP:

Location	Inspected			Functioning			Problem/Corrective Action
	Y	N		Y	N	NIP	

BMP:

Location	Inspected			Functioning			Problem/Corrective Action
	Y	N		Y	N	NIP	

BMP:

Location	Inspected			Functioning			Problem/Corrective Action
	Y	N		Y	N	NIP	

<b>Stormwater Discharges From the Site</b>			
Location	Observed?	Problem/Corrective Action	
		Y	N
Turbidity			
Discoloration			
Sheen			
Location			
Turbidity			
Discoloration			
Sheen			

**Water Quality Monitoring**

Was any water quality monitoring conducted?  Yes  No

If water quality monitoring was conducted, record results here:

If water quality monitoring indicated turbidity 250 NTU or greater; or transparency 6 cm or less, was Ecology notified by phone within 24 hrs?

Yes  No

If Ecology was notified, indicate the date, time, contact name and phone number below:

Date:

Time:

Contact Name:

Phone #:

**General Comments and Notes**

Include BMP repairs, maintenance, or installations made as a result of the inspection.

Were Photos Taken?  Yes  No

If photos taken, describe photos below:

## **APPENDIX D**

---

**To:** Dave Vranizan, Benaroya Capital Company, LLC  
Cara Visintainer, PE, Barghausen Consulting Engineers  
Baxter Hagan, Howard S. Wright

**From:** Debra Overbay PE, GeoEngineers, Inc

**Date:** July 3, 2024

**File:** 4565-064-09

**Subject:** Technical Memorandum – South Hill Business and Technology Center Centeris  
North Detention Pond

---

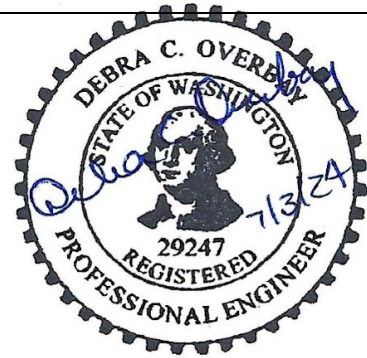

## Introduction

This memorandum documents our geotechnical engineering services in support of the proposed North Utility Yard Detention Pond to be constructed at the South Hill Business and Technology Center in Puyallup, Washington. The overall site location is shown in the attached Figure 1, Vicinity Map.

GeoEngineers, Inc. (GeoEngineers) has been requested to observe test pit explorations in the proposed north utility pond area for the purposes of evaluating infiltration characteristics of the subsurface soils and providing geotechnical retaining wall parameters for the proposed mechanically stabilized earth (MSE) wall. A summary of the site conditions, field exploration, laboratory testing and geotechnical design recommendations within the proposed pond area are provided below

## Field Explorations and Laboratory Testing

### FIELD EXPLORATIONS

Subsurface soil and groundwater conditions were evaluated by excavating three test pits at the approximate locations shown in Figure 2, Centeris North Detention Pond Test Pits. The test pits were excavated using a tracked excavator owned and operated by the earthwork contractor at the site, Johannsen Excavating. Test pits were excavated to depths of 5½ to 10 feet below the ground surface (bgs). A detailed description of the field exploration and testing program and logs of the explorations are presented in Attachment A, Field Explorations and Laboratory Testing

### LABORATORY TESTING

Soil samples obtained from the explorations were transported to GeoEngineers' Redmond, Washington geotechnical laboratory and evaluated to confirm or modify field classifications, as well as to evaluate engineering and index properties of the soil. Selected samples were tested for the determination of moisture content and grain size distribution. A description of the laboratory testing and the test results are presented in Attachment A.

## Geology

We reviewed available geologic maps, including the geologic map of the Tacoma quadrangle (Schuster et al. 2015). The project area is located on a glaciated upland west and south of a major glacial trough, now occupied by the Puyallup River.

Surficial soils mapped in the project vicinity generally consist of geologic units deposited during the Vashon Stade of the Fraser glaciation and include Vashon Till (Qgt), Recessional outwash (Qgo) and ice-contact deposits (Qgoi). Surficial fill is also present at the site from historic grading activities.

Vashon till generally consists of a non-sorted, non-stratified mixture of clay, silt, sand and gravel with larger constituents up to the size of cobbles and boulders. The till is very dense and relatively impermeable but can contain localized zones of interbedded stratified sand and gravel.

Recessional outwash and ice-contact deposits typically consist of stratified outwash sand with some gravel, and some areas of silt and clay. The sediments were deposited by meltwater from the stagnating and receding Vashon glacier and are typically loose to medium dense.

## Site Conditions

### SURFACE CONDITIONS

The South Hill Business and Technology Center is located north of 39<sup>th</sup> Avenue SE, east of Bradley Lake and west of Pierce College in Puyallup, Washington. College Way borders the site to the north. The proposed north detention pond is located on the north side of the Centeris building (Building D) within an undeveloped forested area. Existing ground surface elevations within the proposed pond area range from about Elevation 460 to 464 feet (North American Vertical Datum of 1988 [NAVD 88]). We understand construction of the pond will require cuts on the order of 5 to 10 feet, and the pond bottom elevation will be Elevation 457 feet. An MSE wall is planned along the southern cut, ranging from about 7 to 10 feet in height. The wall design will be a deferred submittal

### SUBSURFACE CONDITIONS

Soils encountered in the explorations consist of recessional outwash in the west and central test pits, and glacial till in the east test pit. The recessional outwash primarily consists of fine to coarse gravel with variable silt content, and occasional cobbles. Test Pit TP-2 encountered a layer of sand with silt beneath the gravel layer. The eastern test pit encountered weathered to unweathered glacial till below a surficial topsoil/forest duff layer. The glacial till is considered a hydraulic restriction layer and is not suitable for infiltration.

### GROUNDWATER CONDITIONS

We did not encounter the static groundwater table during our test pit explorations. Minor perched seepage was encountered on the glacial till in the eastern test pit. Discontinuous perched zones are common within the glacial deposits as seepage from precipitation moves laterally within the unweathered or less permeable layers of the deposits. Perched groundwater conditions are expected to fluctuate as a result of season, precipitation and other factors

See comment on Pg 1 of 239.  
[Storm Report; Pg 194 of 239]

## Conclusions and Recommendations

Based on our observations during the test pit explorations and measurements completed in nearby monitoring well MW-33 located near the proposed entrance to the pond, the static groundwater table is more than 20 feet below existing ground surface. As discussed previously, localized perched zones should be anticipated on the less permeable glacial deposits at the site. Subsurface soils consist of a complex mixture of recessional and ice contact deposits, and very dense glacial till. Although zones of the outwash are more permeable and suitable for infiltration, outwash was not encountered in the eastern test pit. Design and construction considerations for temporary and permanent slopes, earthwork, infiltration considerations and geotechnical parameters for MSE wall design are provided below

### EARTHWORK

Based on the preliminary plan, 5 feet or more of excavation will be required to construct the pond and the adjacent retaining wall. We expect that the proposed earthwork can be accomplished with conventional earthmoving equipment. Although not observed in our test pits, boulders are common within glacial deposits and the contractor should be prepared to remove boulders if encountered.

Portions of the on-site native soils contain sufficient fines content (particles passing the U.S. Standard No. 200 sieve) such that they will be moisture-sensitive and susceptible to disturbance when wet. Site preparation and earthwork should be undertaken during extended periods of dry weather when the surficial soils will be less susceptible to disturbance and provide better support for construction equipment.

### CLEARING AND SITE PREPARATION

All areas to be graded should be cleared of surface and subsurface deleterious matter, including existing trees, brush, vegetation and debris. We recommend stumps and roots larger than 1 inch in diameter be grubbed. Organic soils can be stockpiled and used in landscaping areas.

### SUBGRADE EVALUATION

Following site grading, we recommend the pond surface be evaluated to confirm subsurface soils are as assumed during design. We understand infiltration may be considered for a portion of the pond. Where infiltration is planned, the pond surface should be excavated to final depth and configuration using equipment operating outside the footprint, as practical. The final surface should not be compacted, and may require scarifying based on conditions encountered

### STRUCTURAL FILL

#### *Materials*

Materials used as backfill at the site should meet the requirements below.

- Structural fill placed within the reinforced zone of the MSE wall should consist of Washington State Department of Transportation (WSDOT) Standard Specification 9-03.14(4) Gravel Borrow for Structural Earth Wall.



- Structural fill placed to construct the pond berms should meet the requirements of Common Borrow, WSDOT Standard Specification 9-03.14(3) during dry weather (provided the material can be moisture conditioned to achieve compaction), or WSDOT Standard Specification 9-03.14(1), Gravel Borrow.
- Crushed surfacing should meet the requirements of WSDOT Specification 9-03.9(3).

### *Fill Placement and Compaction Criteria*

Where structural fill is required, the fill should be mechanically compacted to a firm, non-yielding condition. Structural fill should be placed in loose lifts not exceeding 12 inches in thickness. Each lift should be conditioned to the proper moisture content and compacted to the specified density before placing subsequent lifts. The moisture content should not vary more than about two percent above or below the optimum moisture content (OMC). Structural fill should be compacted to the following criteria:

- Structural fill in pavement areas, including utility trench backfill, should be compacted to 90 percent of the maximum dry density (MDD) estimated in general accordance with ASTM International (ASTM) D 1557, except that the upper 2 feet of fill below final subgrade should be compacted to 95 percent of the MDD.
- Structural fill placed as crushed surfacing base course below pavements should be compacted to 95 percent of the MDD estimated in general accordance with ASTM D 1557.

### **TEMPORARY AND PERMANENT SLOPES**

All temporary cut slopes and shoring must comply with the provisions of Title 296 Washington Administrative Code (WAC), Part N, "Excavation, Trenching and Shoring." The contractor performing the work has the primary responsibility for protection of workers and adjacent improvements.

We recommend temporary cut slope inclinations of 1.5H:1V (horizontal to vertical) in the native medium dense soils encountered at the site. Some raveling/sloughing of the cut slopes may occur at this inclination. The inclination may need to be flattened by the contractor if significant sloughing or seepage occurs. These cut slope recommendations apply to fully dewatered conditions. For open cuts at the site, we recommend that:

- No traffic, construction equipment, stockpiles or building supplies be allowed at the top of the cut slopes within a distance of at least 5 feet from the top of the cut.
- Exposed soil along the slope be protected from surface erosion using waterproof tarps or plastic sheeting.
- Construction activities be scheduled so that the length of time the temporary cut is left open is reduced to the extent practicable.
- Erosion control measures be implemented as appropriate such that runoff from the site is reduced to the extent practicable.
- Surface water be diverted away from the excavation.
- The general condition of the slopes should be observed periodically by GeoEngineers to confirm adequate stability.

Because the contractor has control of the construction operations, the contractor should be made responsible for the stability of cut slopes, as well as the safety of the excavations. The contractor should take all necessary steps to ensure the safety of the workers near slopes.

Permanent interior pond cut slopes should be inclined at 3H:1V or flatter. Exterior permanent slopes should be inclined at 2H:1V or flatter.

## MSE RETAINING WALL CONSIDERATIONS

We understand an approximate 5 to 10-foot-high MSE wall will retain the south side of the pond. Based on the subsurface soils encountered in our test pits and the recommended backfill material within the reinforced zone, we recommend the following design parameters for the wall.

TABLE 1. WALL DESIGN PARAMETERS <sup>1,2</sup>

PARAMETER	REINFORCED BACKFILL	RETAINED BACKFILL	FOUNDATION SOIL
Unit Weight (pcf)	130	125	120
Friction Angle (deg)	35	33	32
Cohesion (psf)	0	0	0
Allowable Bearing (psf) <sup>3</sup>	-	-	2,500

Notes:

- <sup>1</sup> Walls should be designed for the planned backslope shown in the plans
- <sup>2</sup> A seismic coefficient of 0.3 (modified peak ground acceleration times 0.5) can be used for seismic design
- <sup>3</sup> If unsuitable soils are encountered at the footing subgrade elevation they should be removed and replaced with structural fill compacted to a minimum 95 percent of the maximum dry density.

These recommendations assume that all retaining walls will be provided with adequate drainage behind the wall.

## INFILTRATION FEASIBILITY

As discussed previously, differing soil conditions resulting in a nonuniform infiltration surface was encountered in the test pits. Very dense glacial till was encountered in the eastern test pit, TP-3, which is considered a hydraulic restriction layer in accordance with the Washington State Department of Ecology Stormwater Management Manual of Western Washington (SMMWW). Granular outwash was encountered in the west and central test pit. Preliminary infiltration rates for the western portion of the pond based on the grain size analyses method are provided in Table 2

The applicant requests to provide a stormwater performance bond and will conduct the required wet season hydraulic conductivity testing and groundwater monitoring this coming wet season

See comment on Pg 1 of 239.  
[Storm Report; Pg 196 of 239]

**TABLE 2. ESTIMATED SOIL HYDRAULIC CONDUCTIVITIES<sup>1</sup>**

Test Pit	Soil Sample Depth (feet)	Percent Fines <sup>2</sup>	D <sub>10</sub> <sup>3</sup>	Estimated Saturated Hydraulic Conductivity with Correction Factor <sup>4</sup> (in/hr)
TP-1	3.5	7	0.85	>20
TP-1	8	2	0.70	>20
TP-2	3.5	5	0.20	5.1
TP-2	7.5	7	0.18	4.2

Notes:

<sup>1</sup> For selected soil samples.

<sup>2</sup> Defined as particles passing the No. 200 sieve.

<sup>3</sup> Defined as grain size in mm for which 10 percent of the sample is more fine.

<sup>4</sup> Correction factor of 0.119 calculated in accordance with Manual (Grain Size Method Correction = 0.4, Site Variability = 0.33, and CFm = 0.9)

## Limitations

We have prepared this memorandum for the exclusive use of Benaroya Capital Company, LLC and their authorized agents for the proposed Centeris North Utility Pond. Within the limitations of scope, schedule and budget, our services have been executed in accordance with generally accepted practices in the field of geotechnical engineering in this area at the time this report was prepared. No warranty or other conditions, express or implied, should be understood. Please refer to Attachment B for additional information pertaining to use of our recommendations.

Attachments:

Figure 1, Vicinity Map

Figure 2, Site Plan

Attachment A. Field Exploration and Laboratory Data

Attachment B. Report Limitations and Guidelines for Use

DCO:atk

Disclaimer: Any electronic form, facsimile or hard copy of the original document (email, text, table, and/or figure), if provided, and any attachments are only a copy of the original document. The original document is stored by GeoEngineers, Inc. and will serve as the official document of record.

## Figures

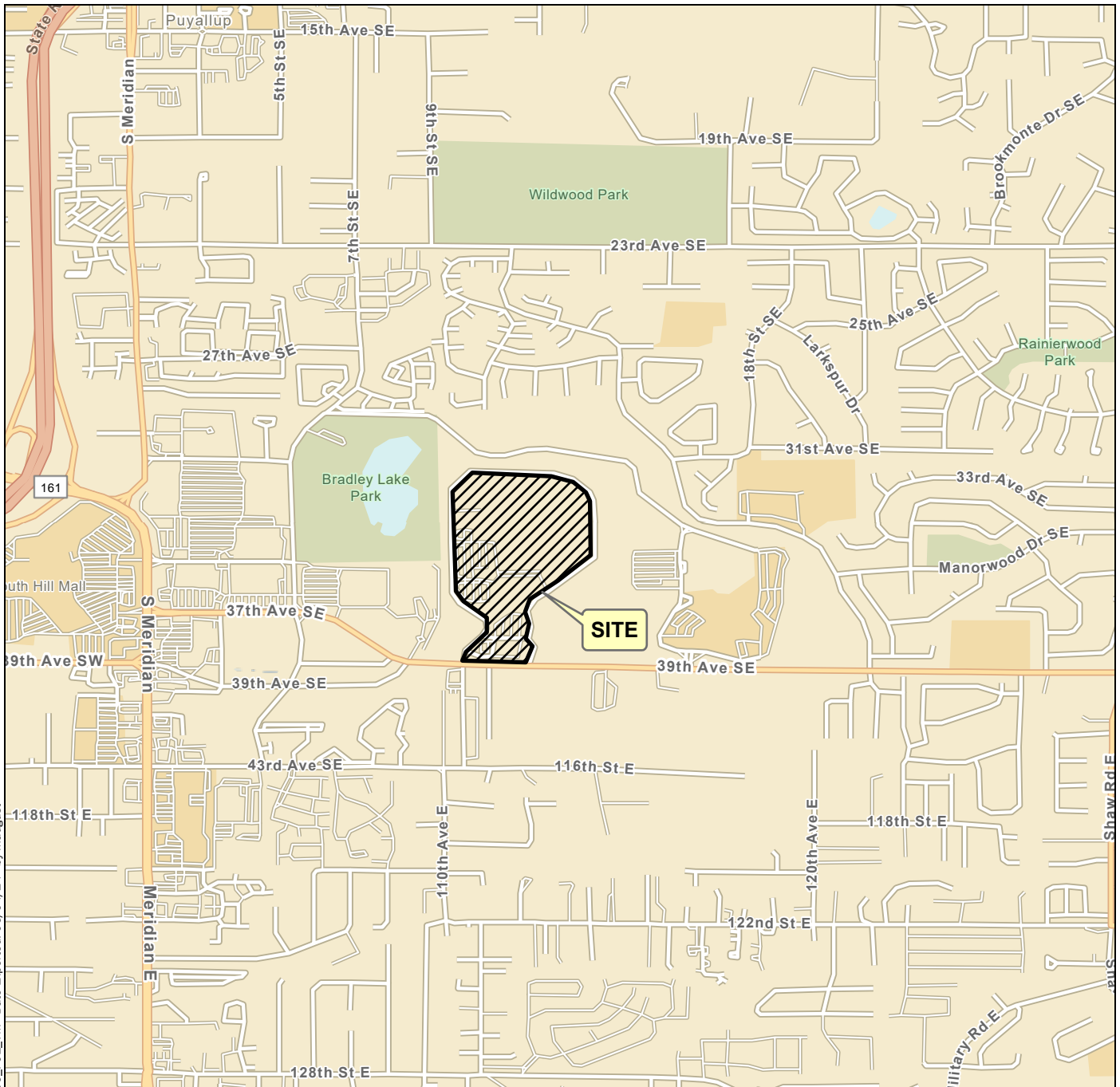

P:\4565064\_106\_GIS\456506406\_Project.aprx 456506406\_Project.aprx 456506409\_F01\_VM Date Exported: 06/04/24 by maugust

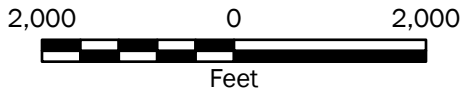
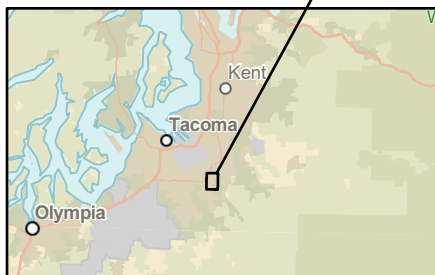

**Notes:**

1. The locations of all features shown are approximate.
2. This drawing is for information purposes. It is intended to assist in showing features discussed in an attached document. GeoEngineers, Inc. cannot guarantee the accuracy and content of electronic files. The master file is stored by GeoEngineers, Inc. and will serve as the official record of this communication.

Data Source: ESRI  
 Projection: NAD 1983 StatePlane Washington South FIPS 4602 Feet

<b>Vicinity Map</b>	
Benaroya Capital Company, LLC South Hill Business & Technology Center Puyallup, Washington	
	<b>Figure 1</b>



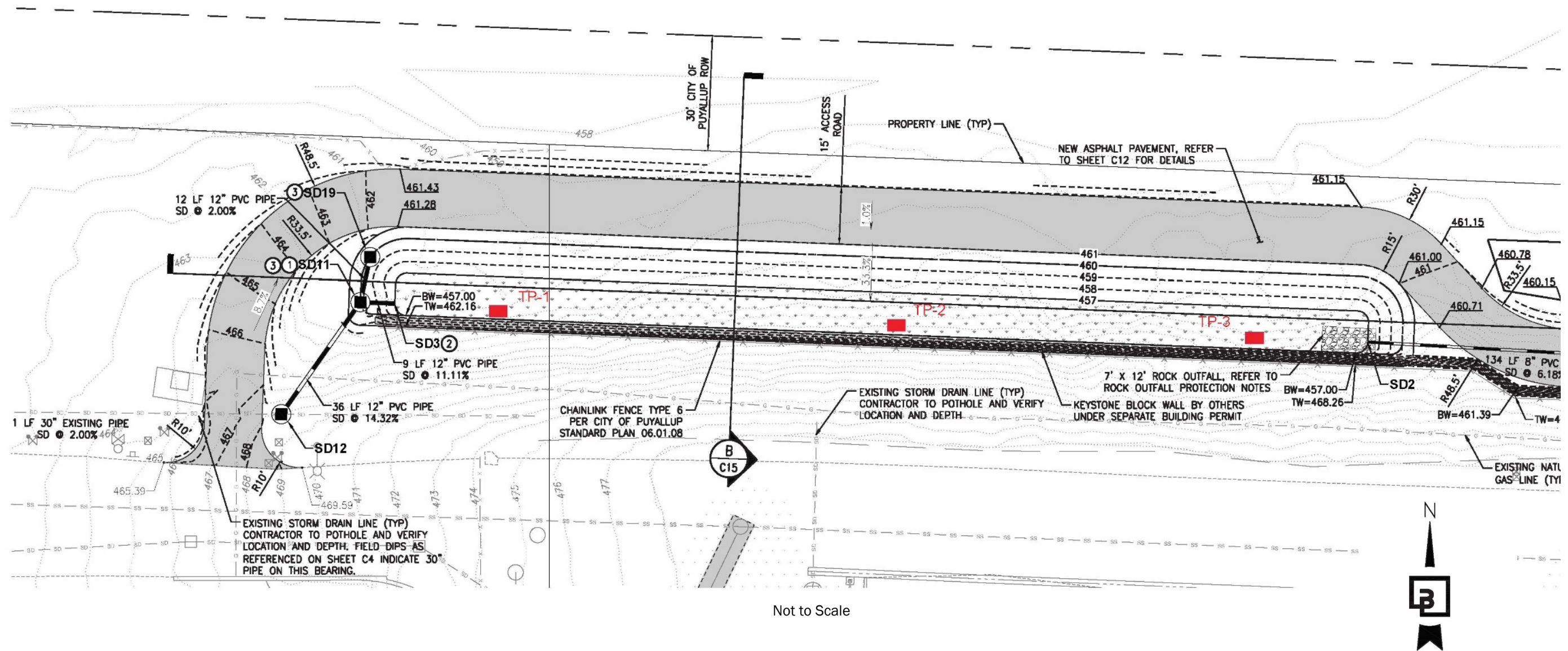

Not to Scale



<b>Centeris North Detention Pond Test Pits</b>	
Benaroya Capital Company, LLC South Hill Business & Technology Center, Puyallup, Washington	
	<b>Figure 2</b>

**Notes:**

1. The locations of all features shown are approximate.
2. This drawing is an excerpt from the drawing, "North Utility Yard Detention Pond, Centeris Voltage Park" by Barghausen Consulting Engineers, Inc. dated 4/25/24 and is for information purposes. It is intended to assist in showing features discussed in an attached document. GeoEngineers, Inc. cannot guarantee the accuracy and content of electronic files. The master file is stored by GeoEngineers, Inc. and will serve as the official record of this communication.

## Appendices

Appendix A  
Field Exploration and Laboratory Data



## SOIL CLASSIFICATION CHART

MAJOR DIVISIONS			SYMBOLS		TYPICAL DESCRIPTIONS
			GRAPH	LETTER	
COARSE GRAINED SOILS  MORE THAN 50% RETAINED ON NO. 200 SIEVE	GRAVEL AND GRAVELLY SOILS  MORE THAN 50% OF COARSE FRACTION RETAINED ON NO. 4 SIEVE	CLEAN GRAVELS  (LITTLE OR NO FINES)		<b>GW</b>	WELL-GRADED GRAVELS, GRAVEL - SAND MIXTURES
		GRAVELS WITH FINES  (APPRECIABLE AMOUNT OF FINES)		<b>GP</b>	POORLY-GRADED GRAVELS, GRAVEL - SAND MIXTURES
		CLEAN SANDS  (LITTLE OR NO FINES)		<b>SW</b>	WELL-GRADED SANDS, GRAVELLY SANDS
		SANDS WITH FINES  (APPRECIABLE AMOUNT OF FINES)		<b>SP</b>	POORLY-GRADED SANDS, GRAVELLY SAND
	SAND AND SANDY SOILS  MORE THAN 50% OF COARSE FRACTION PASSING ON NO. 4 SIEVE	GRAVELS WITH FINES  (APPRECIABLE AMOUNT OF FINES)		<b>GM</b>	SILTY GRAVELS, GRAVEL - SAND - SILT MIXTURES
		CLAYEY GRAVELS, GRAVEL - SAND - CLAY MIXTURES		<b>GC</b>	CLAYEY GRAVELS, GRAVEL - SAND - CLAY MIXTURES
		SANDS WITH FINES  (APPRECIABLE AMOUNT OF FINES)		<b>SM</b>	SILTY SANDS, SAND - SILT MIXTURES
		CLAYEY SANDS, SAND - CLAY MIXTURES		<b>SC</b>	CLAYEY SANDS, SAND - CLAY MIXTURES
FINE GRAINED SOILS  MORE THAN 50% PASSING NO. 200 SIEVE	SILTS AND CLAYS  LIQUID LIMIT LESS THAN 50		<b>ML</b>	INORGANIC SILTS, ROCK FLOUR, CLAYEY SILTS WITH SLIGHT PLASTICITY	
			<b>CL</b>	INORGANIC CLAYS OF LOW TO MEDIUM PLASTICITY, GRAVELLY CLAYS, SANDY CLAYS, SILTY CLAYS, LEAN CLAYS	
			<b>OL</b>	ORGANIC SILTS AND ORGANIC SILTY CLAYS OF LOW PLASTICITY	
	SILTS AND CLAYS  LIQUID LIMIT GREATER THAN 50		<b>MH</b>	INORGANIC SILTS, MICACEOUS OR DIATOMACEOUS SILTY SOILS	
			<b>CH</b>	INORGANIC CLAYS OF HIGH PLASTICITY	
			<b>OH</b>	ORGANIC CLAYS AND SILTS OF MEDIUM TO HIGH PLASTICITY	
HIGHLY ORGANIC SOILS			<b>PT</b>	PEAT, HUMUS, SWAMP SOILS WITH HIGH ORGANIC CONTENTS	

NOTE: Multiple symbols are used to indicate borderline or dual soil classifications

### Sampler Symbol Descriptions

	2.4-inch I.D. split barrel / Dames & Moore (D&M)
	Standard Penetration Test (SPT)
	Shelby tube
	Piston
	Direct-Push
	Bulk or grab
	Continuous Coring

Blowcount is recorded for driven samplers as the number of blows required to advance sampler 12 inches (or distance noted). See exploration log for hammer weight and drop.

"P" indicates sampler pushed using the weight of the drill rig.

"WOH" indicates sampler pushed using the weight of the hammer.

NOTE: The reader must refer to the discussion in the report text and the logs of explorations for a proper understanding of subsurface conditions. Descriptions on the logs apply only at the specific exploration locations and at the time the explorations were made; they are not warranted to be representative of subsurface conditions at other locations or times.

## ADDITIONAL MATERIAL SYMBOLS

SYMBOLS		TYPICAL DESCRIPTIONS
GRAPH	LETTER	
	<b>AC</b>	Asphalt Concrete
	<b>CC</b>	Cement Concrete
	<b>CR</b>	Crushed Rock/ Quarry Spalls
	<b>SOD</b>	Sod/Forest Duff
	<b>TS</b>	Topsoil

### Groundwater Contact



Measured groundwater level in exploration, well, or piezometer



Measured free product in well or piezometer

### Graphic Log Contact



Distinct contact between soil strata



Approximate contact between soil strata

### Material Description Contact



Contact between geologic units



Contact between soil of the same geologic unit

### Laboratory / Field Tests

%F	Percent fines
%G	Percent gravel
AL	Atterberg limits
CA	Chemical analysis
CP	Laboratory compaction test
CS	Consolidation test
DD	Dry density
DS	Direct shear
HA	Hydrometer analysis
MC	Moisture content
MD	Moisture content and dry density
Mohs	Mohs hardness scale
OC	Organic content
PM	Permeability or hydraulic conductivity
PI	Plasticity index
PL	Point lead test
PP	Pocket penetrometer
SA	Sieve analysis
TX	Triaxial compression
UC	Unconfined compression
UU	Unconsolidated undrained triaxial compression
VS	Vane shear

### Sheen Classification

NS	No Visible Sheen
SS	Slight Sheen
MS	Moderate Sheen
HS	Heavy Sheen

## Key to Exploration Logs

Date Excavated	5/30/2024	Total Depth (ft)	10	Logged By	PW	Excavator	Komatsu mid-size track mount	Groundwater not observed
				Checked By	DCO	Equipment	PC 88MR	Caving not observed
Surface Elevation (ft) Vertical Datum	461		Easting (X) Northing (Y)			Coordinate System Horizontal Datum	WA North	

Elevation (feet)	Depth (feet)	SAMPLE		Graphic Log	Group Classification	MATERIAL DESCRIPTION	Moisture Content (%)	Fines Content (%)	REMARKS
		Testing Sample	Sample Name Testing						
460	1				SM	Dark brown silty fine sand with gravel and trace organics (roots) (loose, moist) (topsoil, rootzone)			
459	2		S-1		GW	Orange-brown fine to coarse gravel with sand (dense, moist) (outwash)			
458	3				GP-GM	Tan-brown fine to coarse gravel with silt, sand and cobbles to 3 to 6 inches			
457	4		S-2		GP-GM	Tan-brown fine to coarse gravel with silt, sand and cobbles to 3 to 6 inches	4	7	
456	5				GP/GW	Gray-brown fine to coarse gravel with sand and cobbles (dense, moist)			
455	6		S-3		GP/GW	Gray-brown fine to coarse gravel with sand and cobbles (dense, moist)			
454	7				GP/GW	Grades with less cobbles			
453	8		S-4		GW	Gray-brown fine to coarse gravel with occasional cobbles (dense, moist)	3	2	
452	9								
451	10								
Bottom of test pit exploration 10 feet (practical refusal of excavator)									

Notes: See Figure A-1 for explanation of symbols.  
The depths on the test pit logs are based on an average of measurements across the test pit and should be considered accurate to 1/2 foot.  
Coordinates Data Source: Horizontal approximated based on . Vertical approximated based on Survey by H.S. Wright dated May 30, 2024.

### Log of Test Pit TP-1



Project: Benaroya North Gen Yard - Detention Pond  
Project Location: Puyallup, Washington  
Project Number: 4565-064-09

Figure A-2  
Sheet 1 of 1

Date: 6/18/24 Path: P:\4565\064-09\4565064-09.GPJ DBLibrary/Library\GEOENGINEERS\_DF\_STD\_US\_JUNE\_2017.GLB\GEB\_TESTPIT\_IP\_GEOTEC\_%F

Date Excavated	5/30/2024	Total Depth (ft)	9.5	Logged By	PW	Excavator	Komatsu mid-size track mount	Groundwater not observed
				Checked By	DCO	Equipment	PC 88MR	Caving not observed
Surface Elevation (ft) Vertical Datum	466		Easting (X) Northing (Y)			Coordinate System Horizontal Datum	WA North	

Elevation (feet)	Depth (feet)	SAMPLE		Graphic Log	Group Classification	MATERIAL DESCRIPTION	Moisture Content (%)	Fines Content (%)	REMARKS
		Testing Sample	Sample Name Testing						
465	1				SM	Dark brown silty fine sand with gravel and cobbles and trace organics (roots) (loose, moist) (topsoil/forest duff)			
464	2		S-1		SM	Orange-brown silty fine sand with gravel and cobbles to 3 to 6 inches (medium dense, moist)			
463	3				GP	Orange-brown fine to coarse sand with gravel and cobbles to 3 to 6 inches (medium dense, moist) (outwash)	4	5	
462	4		S-2						
461	5					Becomes yellow-brown at 5 feet			
460	6		S-3		SP-SM	Gray medium sand with silt, gravel and cobbles (very dense, moist)	8	7	
459	7								
458	8		S-4						
457	9								

Bottom of test pit exploration 9½ feet due to practical refusal of excavator

Notes: See Figure A-1 for explanation of symbols.  
 The depths on the test pit logs are based on an average of measurements across the test pit and should be considered accurate to ½ foot.  
 Coordinates Data Source: Horizontal approximated based on . Vertical approximated based on Survey by H.S. Wright dated May 30, 2024.

### Log of Test Pit TP-2



Project: Benaroya North Gen Yard - Detention Pond  
 Project Location: Puyallup, Washington  
 Project Number: 4565-064-09

Date: 6/18/24 Path: P:\4565\064-09\45665064\09.GPJ DBLibrary/Library\GEOENGINEERS\_DF\_STD\_US\_JUNE\_2017.GLB\GEB\_TESTPIT\_IP\_GEOTEC\_%F

Date Excavated	5/30/2024	Total Depth (ft)	5.5	Logged By	PW	Excavator	Komatsu mid-size track mount	See "Remarks" section for groundwater observed
				Checked By	DCO	Equipment	PC 88MR	
Surface Elevation (ft) Vertical Datum	465			Easting (X) Northing (Y)	Coordinate System Horizontal Datum			WA North

Elevation (feet)	Depth (feet)	SAMPLE		Graphic Log	Group Classification	MATERIAL DESCRIPTION	Moisture Content (%)	Fines Content (%)	REMARKS
		Testing Sample	Sample Name Testing						
464	1				SM	Dark brown silty fine sand with gravel and trace organics (roots) (loose, moist) (topsoil/forest duff)			
463	2		S-1		SM	Orange-brown silty fine to coarse sand with gravel and cobbles to 3 to 6 inches (medium dense, moist) (weathered till)			
462	3								
461	4		S-2		ML	Gray sandy silt with occasional gravel (very dense, moist) (glacial till)			
460	5		S-3				14	64	

Bottom of test pit exploration 5½ feet due to practical refusal of excavator

Very slight water seep at 5½ feet from east side of pit

Notes: See Figure A-1 for explanation of symbols.  
 The depths on the test pit logs are based on an average of measurements across the test pit and should be considered accurate to ½ foot.  
 Coordinates Data Source: Horizontal approximated based on . Vertical approximated based on Survey by H.S. Wright dated May 30, 2024.

### Log of Test Pit TP-3



Project: Benaroya North Gen Yard - Detention Pond  
 Project Location: Puyallup, Washington  
 Project Number: 4565-064-09

Figure A-4  
 Sheet 1 of 1

Date: 6/18/24 Path: P:\4565\064-09\4565064-09.GPJ DBLibrary/Library\GEOENGINEERS\_DF\_STD\_US\_JUNE\_2017.GLB\GEB\_TESTPIT\_IP\_GEOTEC\_%F

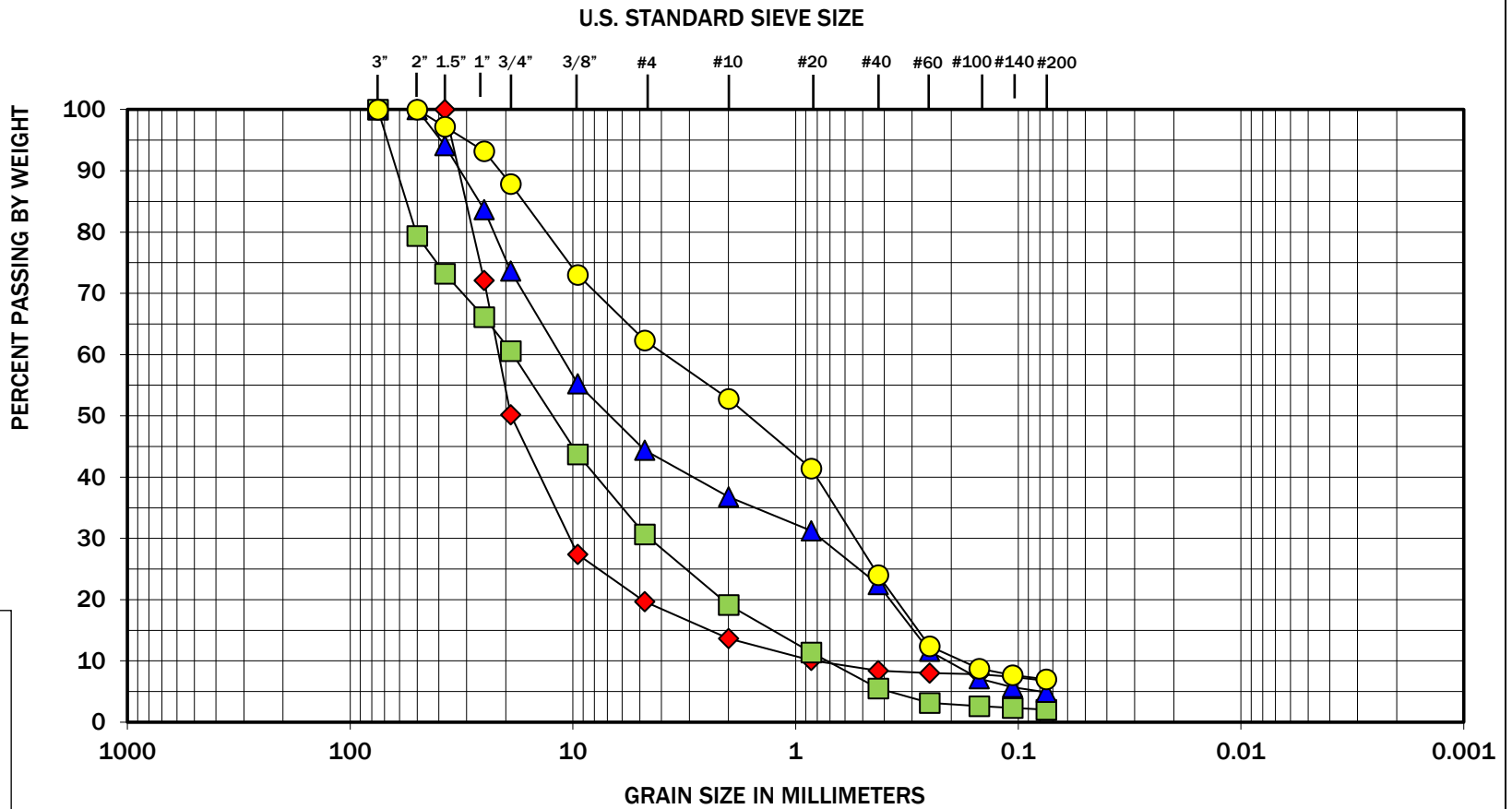

COBBLES	GRAVEL		SAND			SILT OR CLAY
	COARSE	FINE	COARSE	MEDIUM	FINE	

Symbol	Boring Number	Depth (feet)	Moisture (%)	Soil Description
◆	TP-1	3.5	4	Poorly graded gravel with silt (GP-GM)
■	TP-1	8	3	Well-graded gravel with sand (GW)
▲	TP-2	3.5	4	Poorly graded gravel with sand (GP)
●	TP-2	7.5	8	Poorly graded sand with silt and gravel (SP-SM)



Note: This report may not be reproduced, except in full, without written approval of GeoEngineers, Inc. Test results are applicable only to the specific sample on which they were performed, and should not be interpreted as representative of any other samples obtained at other times, depths or locations, or generated by separate operations or processes.

The grain size analysis results were obtained in general accordance with ASTM D6913. GeoEngineers 17425 NE Union Hill Road Ste 250, Redmond, WA 98052

**Benaroya South Hill**  
Puyallup, Washington

**Sieve Analysis Results**

**Figure A-5**

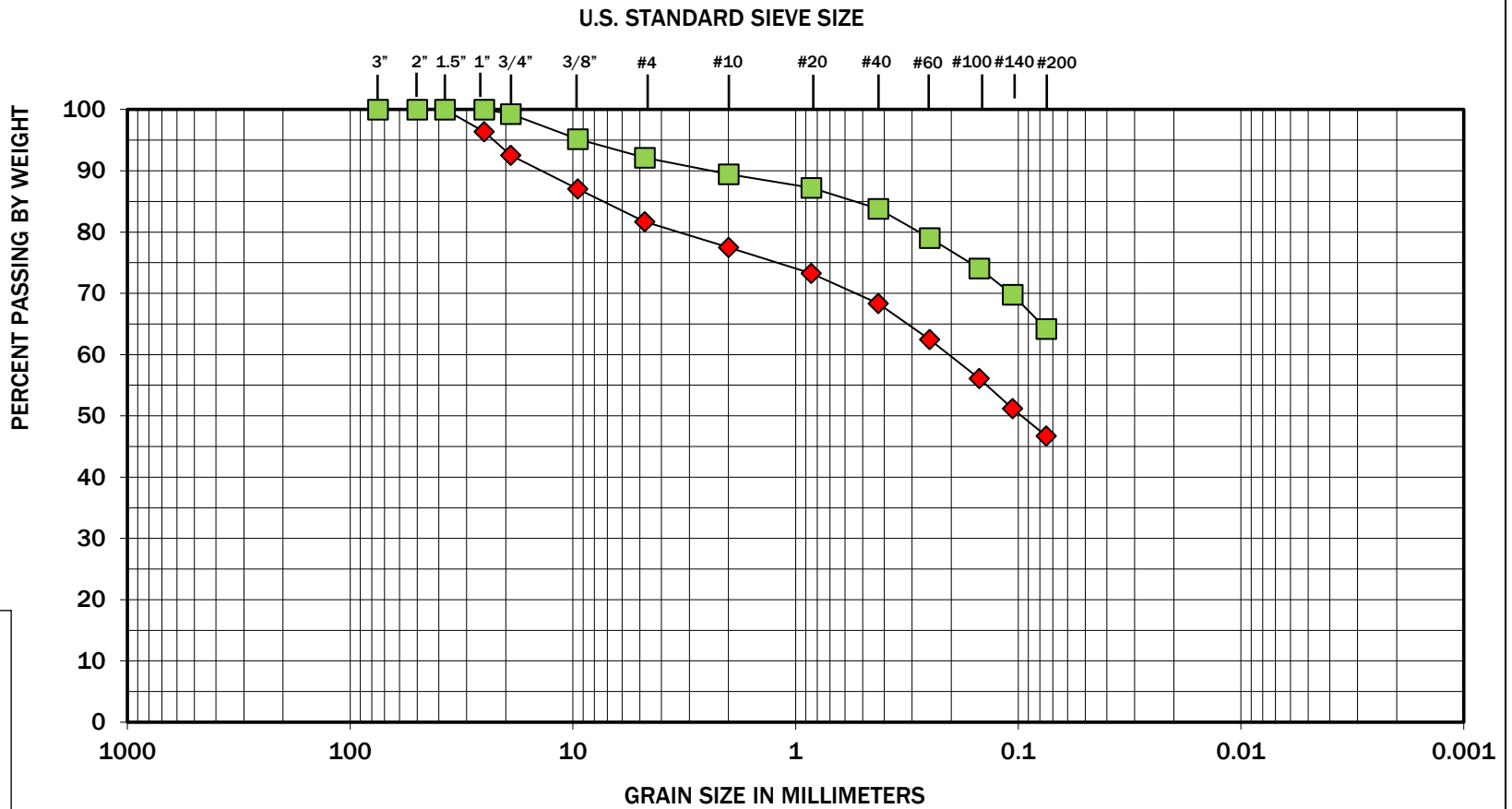

COBBLES	GRAVEL		SAND			SILT OR CLAY
	COARSE	FINE	COARSE	MEDIUM	FINE	

Symbol	Boring Number	Depth (feet)	Moisture (%)	Soil Description
◆	TP-3	3.5	14	Silty sand with gravel (SM)
■	TP-3	5	14	Sandy silt (ML)

**GEOENGINEERS**



Benaroya South Hill  
Puyallup, Washington

**Sieve Analysis Results**

**Figure A-6**



Note: This report may not be reproduced, except in full, without written approval of GeoEngineers, Inc. Test results are applicable only to the specific sample on which they were performed, and should not be interpreted as representative of any other samples obtained at other times, depths or locations, or generated by separate operations or processes.

The grain size analysis results were obtained in general accordance with ASTM D6913. GeoEngineers 17425 NE Union Hill Road Ste 250, Redmond, WA 98052

## Appendix B

### Report Limitations and Guidelines for Use

## Appendix B

### REPORT LIMITATIONS AND GUIDELINES FOR USE<sup>1</sup>

This appendix provides information to help you manage your risks with respect to the use of this report.

#### *Read These Provisions Closely*

It is important to recognize that the geoscience practices (geotechnical engineering, geology, and environmental science) rely on professional judgment and opinion to a greater extent than other engineering and natural science disciplines, where more precise and/or readily observable data may exist. To help clients better understand how this difference pertains to our services, GeoEngineers includes the following explanatory “limitations” provisions in its reports. Please confer with GeoEngineers if you need to know more how these “Report Limitations and Guidelines for Use” apply to your project or site.

#### *Geotechnical Services Are Performed for Specific Purposes, Persons, and Projects*

This report has been prepared for the Benaroya Capital Company, LLC and for the Project(s) specifically identified in the report. The information contained herein is not applicable to other sites or projects.

GeoEngineers structures its services to meet the specific needs of its clients. No party other than the party to whom this report is addressed may rely on the product of our services unless we agree to such reliance in advance and in writing. Within the limitations of the agreed scope of services for the Project, and its schedule and budget, our services have been executed in accordance with our Agreement with Benaroya Capital Company, LLC dated April 5, 2023 and generally accepted geotechnical practices in this area at the time this report was prepared. We do not authorize, and will not be responsible for, the use of this report for any purposes or projects other than those identified in the report.

#### *A Geotechnical Engineering or Geologic Report is Based on a Unique Set of Project-Specific Factors*

This report has been prepared for the Centeris North Utility Pond project in Puyallup, Washington. GeoEngineers considered a number of unique, project-specific factors when establishing the scope of services for this project and report. Unless GeoEngineers specifically indicates otherwise, it is important not to rely on this report if it was:

- Not prepared for you,
- Not prepared for your project,
- Not prepared for the specific site explored, or
- Completed before important project changes were made.

For example, changes that can affect the applicability of this report include those that affect:

---

<sup>1</sup> Developed based on material provided by GBA, GeoProfessional Business Association; [www.geoprofessional.org](http://www.geoprofessional.org).



- The function of the proposed structure;
- Elevation, configuration, location, orientation, or weight of the proposed structure;
- Composition of the design team; or
- Project ownership.

If changes occur after the date of this report, GeoEngineers cannot be responsible for any consequences of such changes in relation to this report unless we have been given the opportunity to review our interpretations and recommendations. Based on that review, we can provide written modifications or confirmation, as appropriate.

### ***Subsurface Conditions Can Change***

This geotechnical or geologic report is based on conditions that existed at the time the study was performed. The findings and conclusions of this report may be affected by the passage of time, by man-made events such as construction on or adjacent to the site, new information or technology that becomes available subsequent to the report date, or by natural events such as floods, earthquakes, slope instability or groundwater fluctuations. If more than a few months have passed since issuance of our report or work product, or if any of the described events may have occurred, please contact GeoEngineers before applying this report for its intended purpose so that we may evaluate whether changed conditions affect the continued reliability or applicability of our conclusions and recommendations.

### ***Geotechnical and Geologic Findings Are Professional Opinions***

Our interpretations of subsurface conditions are based on field observations from widely spaced sampling locations at the site. Site exploration identifies the specific subsurface conditions only at those points where subsurface tests are conducted or samples are taken. GeoEngineers reviewed field and laboratory data and then applied its professional judgment to render an informed opinion about subsurface conditions at other locations. Actual subsurface conditions may differ, sometimes significantly, from the opinions presented in this report. Our report, conclusions and interpretations are not a warranty of the actual subsurface conditions.

### ***Geotechnical Engineering Report Recommendations Are Not Final***

We have developed the following recommendations based on data gathered from subsurface investigation(s). These investigations sample just a small percentage of a site to create a snapshot of the subsurface conditions elsewhere on the site. Such sampling on its own cannot provide a complete and accurate view of subsurface conditions for the entire site. Therefore, the recommendations included in this report are preliminary and should not be considered final. GeoEngineers' recommendations can be finalized only by observing actual subsurface conditions revealed during construction. GeoEngineers cannot assume responsibility or liability for the recommendations in this report if we do not perform construction observation.

We recommend that you allow sufficient monitoring, testing and consultation during construction by GeoEngineers to confirm that the conditions encountered are consistent with those indicated by the explorations, to provide recommendations for design changes if the conditions revealed during the work differ from those anticipated, and to evaluate whether earthwork activities are completed in accordance with our recommendations. Retaining GeoEngineers for construction observation for this project is the most effective means of managing the risks associated with unanticipated conditions. If another party performs field observation and confirms our expectations, the other party must take full responsibility for both the observations and recommendations. Please note, however, that another party would lack our project-specific knowledge and resources.

### ***A Geotechnical Engineering or Geologic Report Could Be Subject to Misinterpretation***

Misinterpretation of this report by members of the design team or by contractors can result in costly problems. GeoEngineers can help reduce the risks of misinterpretation by conferring with appropriate members of the design team after submitting the report, reviewing pertinent elements of the design team's plans and specifications, participating in pre-bid and preconstruction conferences, and providing construction observation.

### ***Give Contractors a Complete Report and Guidance***

To help reduce the risk of problems associated with unanticipated subsurface conditions, GeoEngineers recommends giving contractors the complete geotechnical engineering or geologic report, including these "Report Limitations and Guidelines for Use." When providing the report, you should preface it with a clearly written letter of transmittal that:

- Advises contractors that the report was not prepared for purposes of bid development and that its accuracy is limited; and
- Encourages contractors to conduct additional study to obtain the specific types of information they need or prefer.

### ***Contractors Are Responsible for Site Safety on Their Own Construction Projects***

Our geotechnical recommendations are not intended to direct the contractor's procedures, methods, schedule, or management of the work site. The contractor is solely responsible for job site safety and for managing construction operations to minimize risks to on-site personnel and adjacent properties.

July 3, 2024

Benaroya Capital Company LLC  
9675 SE 36<sup>th</sup> Street, Suite 115  
Mercer Island, Washington 98040

Attention: Dave Vranizan

Subject: Letter Report  
Geotechnical Engineering Services  
Centeris South Utility Yard  
Puyallup, Washington  
File No. 4565-064-09, Task 400

## Introduction

This letter presents the results of GeoEngineers, Inc.'s (GeoEngineers) geotechnical engineering services for earthwork and foundation design for the Centeris South Utility Yard located at the South Hill Business and Technology Center in Puyallup, Washington. The overall site location is shown in Figure 1, Vicinity Map and the locations of the borings completed in the South Utility Yard area are shown in Figure 2, Centeris South Yard Borings.

GeoEngineers has been requested to provide earthwork and foundation support recommendations for the new equipment pads. Four borings were requested within the yard area where 10 to 15 feet of cut is required to construct the stepped foundation pads. A summary of the site conditions, field exploration, laboratory testing and geotechnical design recommendations are provided below.

## Field Explorations and Laboratory Testing

### FIELD EXPLORATIONS

Subsurface soil and groundwater conditions were evaluated by drilling four borings at the approximate locations shown in the attached Figure 2. The borings were advanced to depths ranging from 16½ to 20½ feet below the ground surface (bgs). A detailed description of the field exploration and testing program and logs of the explorations are presented in Attachment A, Field Explorations and Laboratory Testing.

## LABORATORY TESTING

Soil samples obtained from the explorations were transported to GeoEngineers' Redmond, Washington geotechnical laboratory and evaluated to confirm or modify field classifications, as well as to evaluate engineering and index properties of the soil. Selected samples were tested for the determination of moisture content, grain size distribution, percent fines and resistivity. A description of the laboratory testing and the test results are presented in Attachment A.

## Geology

We reviewed available geologic maps, including the geologic map of the Tacoma quadrangle (Schuster et al. 2015). The project area is located on a glaciated upland west and south of a major glacial trough, now occupied by the Puyallup River.

Surficial soils mapped in the project vicinity generally consist of geologic units deposited during the Vashon Stade of the Fraser glaciation and include Vashon Till (Qgt), Recessional outwash (Qgo) and ice-contact deposits (Qgoi). Surficial fill is also present at the site from historic grading activities.

Vashon till generally consists of a non-sorted, non-stratified mixture of clay, silt, sand and gravel with larger constituents up to the size of cobbles and boulders. The till is very dense and relatively impermeable but can contain localized zones of interbedded stratified sand and gravel.

Recessional outwash and ice-contact deposits typically consist of stratified outwash sand with some gravel, and some areas of silt and clay. The sediments were deposited by meltwater from the stagnating and receding Vashon glacier and are typically loose to medium dense.

## Site Conditions

### *Surface Conditions*

The South Hill Business and Technology Center is located north of 39<sup>th</sup> Avenue SE, east of Bradley Lake and west of Pierce College in Puyallup, Washington. College Way borders the site to the north. The Centeris site is located at the north end of the business park. The existing ground surface elevations within the south utility yard area range from about Elevation 484 feet in the west to Elevation 507 feet in the east (North American Vertical Datum of 1988 [NAVD 88]).

### *Subsurface Conditions*

Soils encountered in the explorations consist of fill overlying complex layering of recessional outwash/ice contact deposits. In general, medium dense silty sand and sand with silt with variable gravel content was encountered in each boring. The upper silty sand was loose in the upper portion of Boring B-4 to a depth of approximately 9 feet, and at the bottom of Boring B-2. Although not retrieved in the small diameter sampler, cobbles have been observed in test pits completed around the Centeris building.

## **Groundwater Conditions**

Groundwater seepage was not observed in the borings at the time of drilling, however the borings were not left open for an extended period. Discontinuous perched zones may be encountered during site excavations. Groundwater conditions are expected to fluctuate as a result of season, precipitation and other factors.

## **Conclusions and Recommendations**

Based on the results of our subsurface explorations and our geotechnical engineering evaluation, it is our opinion that the proposed South Utility Yard may be constructed successfully as planned. We understand the areal loading of the equipment pads are similar to the north pad area, in the range of 100 to 250 pounds per square foot (psf).

Based on the preliminary plan, up to about 12 feet of excavation will be required to form the utility slabs. Our borings encountered medium dense to dense silty sand and sand with silt at anticipated foundation depth. Recommendations for support of the equipment slabs, earthwork and seismic design considerations are presented below.

### **SHALLOW FOUNDATIONS**

#### ***Footing Subgrade***

We understand the pad perimeters, new walls and other individual equipment foundations will be supported on shallow foundations. We recommend shallow foundations be founded on recompacted medium dense to dense silty sand soils, or on a minimum 18 inch thickness of structural fill. If the exposed native soils cannot be recompacted due to excessive moisture, excavation and replacement with structural fill will be appropriate as recommended by the geotechnical engineer.

#### ***Allowable Bearing Pressure***

Shallow foundations may be designed using an allowable soil bearing pressure of 2,500 psf for footings supported on subgrade soils prepared as described above. The allowable soil bearing pressure applies to the total of dead and long-term live loads and may be increased by up to one-third for wind or seismic loads. Frost penetration depth in the project area is typically 12 inches; therefore, we recommend that footings be founded at least 18 inches below the lowest adjacent finished grade.

#### ***Construction Considerations***

Where footings are supported on structural fill, the zone of structural fill should extend laterally beyond the footing edges a horizontal distance at least equal to the thickness of the fill. The condition of all subgrade areas should be observed by GeoEngineers to evaluate whether the subgrade preparation is completed in accordance with our recommendations and whether the subsurface conditions are as anticipated.

Provided all loose soil is removed and the subgrade is prepared as recommended, we estimate that the total settlement of shallow foundations will be less than about  $\frac{3}{4}$  inch. The settlement will occur rapidly, essentially as loads are applied. Differential settlements between footings could be half of the total settlement.

## LATERAL RESISTANCE

Lateral foundation loads may be resisted by passive resistance on the sides of footings and by friction on the base of the shallow foundations. For shallow foundations supported on the recompacted native soils or on structural fill, the allowable frictional resistance may be computed using a coefficient of friction of 0.4 applied to vertical dead-load forces.

The allowable passive resistance may be computed using an equivalent fluid density of 300 pounds per cubic foot (pcf) (triangular distribution). These values are appropriate for foundation elements that are surrounded by medium dense to dense native soils or compacted structural fill. The structural fill should extend out from the face of the foundation for a distance equal to at least 2½ times the depth of the foundation element. These values also assume the ground surface in front of the footing will be level for a horizontal distance equal to at least 2 times the depth of the footing. If soils adjacent to footings are disturbed during construction, the disturbed soils must be recompacted; otherwise, the lateral passive resistance value must be reduced.

Resistance to passive pressure should be calculated from the bottom of adjacent slabs and paving, or below a depth of 1 foot where the adjacent area is unpaved, as appropriate. The above coefficient of friction and passive equivalent fluid density values incorporate a factor of safety of about 1.5.

## BELOW-GRADE WALLS AND RETAINING WALLS

### *Design Parameters*

Lateral earth pressures for design of below-grade walls and retaining structures should be evaluated using an equivalent fluid density of 35 pcf provided that the walls will not be restrained against rotation when backfill is placed. If the walls will be restrained from rotation, we recommend using an equivalent fluid density of 55 pcf. Walls are assumed to be restrained if top movement during backfilling is less than  $H/1000$ , where  $H$  is the wall height. These lateral soil pressures assume that the ground surface behind the wall is horizontal. For unrestrained walls with backfill sloping up at 2H:1V (horizontal to vertical), the design lateral earth pressure should be increased to 55 pcf, while restrained walls with a 2H:1V sloping backfill should be designed using an equivalent fluid density of 75 pcf. These lateral soil pressures do not include the effects of surcharges such as slab/floor loads, traffic loads or other surface loading. Surcharge effects should be included as appropriate. Seismic earth pressures should also be considered in design using a rectangular distribution of  $8H$  in psf, where  $H$  is the wall height.

These recommendations assume that all retaining walls will be provided with adequate drainage. The values for soil bearing, frictional resistance and passive resistance presented above for foundation design are applicable to retaining wall design. Walls located in level ground areas should be founded at a depth of 18 inches below the adjacent grade.

### *Wall Drainage*

To reduce the potential for hydrostatic water pressure buildup behind retaining walls, we recommend that the walls be provided with adequate drainage. Wall drainage can be achieved by using free draining wall drainage material with perforated pipes to discharge the collected water.

Wall drainage material may consist of Gravel Backfill for Walls per Washington State Department of Transportation (WSDOT) Standard Specification Section 9-03.12(2) surrounded with a nonwoven geotextile filter fabric such as Mirafi 140N (or approved equivalent), or imported Gravel Borrow with less than 5 percent fines may be used in conjunction with a geocomposite wall drainage layer. The zone of wall drainage material should be 2 feet wide and should extend from the base of the wall to within 2 feet of the ground surface. The wall drainage material should be covered with a geotextile separator (such as Mirafi 140N) and then 2 feet of less permeable material, such as the on-site silty sand that is properly moisture conditioned and compacted.

A 4-inch-diameter perforated drain pipe should be installed within the free-draining material at the base of each wall. We recommend using either heavy-wall solid pipe (SDR-35 PVC) or rigid corrugated polyethylene pipe (ADS N-12, or equal). We recommend against using flexible tubing for the wall drain pipe. The footing drain recommended above can be incorporated into the bottom of the drainage zone and used for this purpose. If gravel borrow is used against the wall in conjunction with a geocomposite wall drainage layer, then the drainage pipe at the base of the wall should be surrounded with at least 12 inches of Gravel Backfill for Drains per WSDOT Standard Specification Section 9-03.12(4) that is wrapped with a nonwoven geotextile filter fabric such as Mirafi 140N (or approved equivalent).

The pipes should be laid with minimum slopes of one-quarter percent and discharged to a suitable discharge. The pipe installations should include a cleanout riser with cover located at the upper end of each pipe run. The cleanouts could be placed in flush mounted access boxes. Where applicable, collected downspout water should be routed to appropriate discharge points in separate pipe systems.

## SLAB-ON-GRADE OR UTILITY SLABS

Equipment slabs may be supported on a minimum 4-inch thickness of base rock overlying the recompacted medium dense to dense native soils. To provide a level foundation pad and prevent disturbance, we recommend placing a minimum 4-inch-thick layer of crushed rock beneath new slabs. The exposed subgrade soils should be compacted to 95 percent of the maximum dry density (MDD) in accordance with ASTM International (ASTM) D-1557 prior to crushed rock placement. If this is not possible or if soft soils are encountered, we recommend that the unsuitable soils be overexcavated and replaced with compacted crushed rock or structural fill. The thickness of the crushed rock layer will depend on the condition of the subgrade soils at the time of construction. Placing a geotextile fabric such as Mirafi 500X (or similar material) may also be necessary to help stabilize the subgrade during inclement weather.

Provided the slab foundations are constructed on the recommended base layer, the foundation performance can be evaluated using a modulus of subgrade reaction of 100 pounds per cubic inch (pci). We recommend the geotechnical engineer observe the excavation for base rock, evaluate the exposed subgrade by proof-rolling or performing hand probing, monitor the compaction of the base rock and recommend modifications if required.

## SEISMIC DESIGN CONSIDERATIONS

### *Regional Seismicity*

The Puget Sound region is located at the convergent continental boundary known as the Cascadia Subduction Zone (CSZ), which extends from mid-Vancouver Island to Northern California. The CSZ is the zone where the westward advancing North American Plate is overriding the subducting Juan de Fuca Plate. The interaction of these two plates results in three potential seismic source zones: (1) a shallow crustal source zone; (2) the Benioff source zone and (3) the CSZ interplate source zone.

The shallow crustal source zone is used to characterize shallow crustal earthquake activity within the North American Plate at depths ranging from 3 to 19 miles bgs. The closest fault traces are located approximately 9 miles north of the site, suspected traces of the Tacoma Fault Zone.

The Benioff source zone is used to characterize intraplate, intraslab or deep subcrustal earthquakes. Benioff source zone earthquakes occur within the subducting Juan de Fuca Plate at depths between 20 and 40 miles. In recent years, three large Benioff source zone earthquakes occurred that resulted in some liquefaction in loose alluvial deposits and significant damage to some structures. The first earthquake, which was centered in the Olympia area, occurred in 1949 and had a Richter magnitude of 7.1. The second earthquake, which was centered between Seattle and Tacoma, occurred in 1965 and had a Richter magnitude of 6.5. The third earthquake, which was located in the Nisqually Valley north of Olympia, occurred in 2001 and had a Richter magnitude of 6.8.

The CSZ interplate source zone is used to characterize rupture of the convergent boundary between the subducting Juan de Fuca Plate and the overriding North American Plate. The depth of CSZ earthquakes is greater than 40 miles. No earthquakes on the CSZ have been instrumentally recorded; however, through the geologic record and historical records of tsunamis in Japan, it is believed that the most recent CSZ event occurred in 1700.

### 2021 IBC Seismic Design Parameters

The 2021 International Building Code (IBC) references the 2016 version of Minimum Design Loads for Buildings and Other Structures (American Society of Civil Engineers [ASCE] 7-16) for the Site Class determination and the development of seismic design parameters. Based on the subsurface conditions in current and historic borings at the site, and per ASCE 7-16 Section 20.3.1, the site is classified as Site Class C. IBC seismic parameters are provided in Table 1, 2021 IBC Seismic Parameters.

**TABLE 1. 2021 IBC SEISMIC PARAMETERS**

2018 IBC PARAMETER1	VALUE
Site Class	C
Mapped $MCE_R$ Spectral Response Acceleration at Short Period, $S_s$ (g)	1.257
Mapped $MCE_R$ Spectral Response Acceleration at 1-second period, $S_1$ (g)	0.434
Short Period Site Coefficient, $F_a$	1.20
Long Period Site Coefficient, $F_v$	1.5
Design Spectral Acceleration at 0.2-second period, $S_{DS}$ (g)	1.006
$T_s$ (sec)	0.62

Notes:

- Parameters developed based on latitude 47.16084 and longitude -122.27953 using the ASCE Hazard Tool

In accordance with IBC 2021 and ASCE 7-16 and consistent with the parameters presented above, we recommend a modified peak ground acceleration ( $PGA_M$ ) of 0.6 g.



## ***Liquefaction and Liquefaction-induced Settlement***

Liquefaction refers to the condition when vibration or shaking of the ground, usually from earthquake forces, results in the development of excess pore pressures in saturated soils with subsequent loss of strength in the deposit of soil so affected. In general, soils that are susceptible to liquefaction include very loose to medium dense clean to silty sands and some silts that are below the water table. Liquefaction usually results in ground settlement and loss of bearing capacity, resulting in settlement of structures that are supported on foundations that are constructed within or above the liquefied soils.

Based on the site geology, and the subsurface soil and groundwater conditions encountered in our borings, in our opinion the site has low potential for liquefaction.

## **EARTHWORK**

### ***Subgrade Preparation***

The exposed subgrade in structure areas should be evaluated after grading is complete and prior to placing base rock by probing or proof-rolling, as appropriate. Proof-rolling should be observed by a representative from our firm to recommend removal of soft or unsuitable soils as appropriate. The exposed soil should be firm and unyielding, and without significant groundwater.

If the exposed subgrade is not acceptable based on the proof-roll, we recommend that unsuitable soils be overexcavated to a maximum depth of 2 feet and replaced with imported structural fill. We anticipate that unsuitable soils will not be able to be moisture-conditioned and recompacted. Areas that are overexcavated and replaced with structural fill should be re-evaluated by proof-rolling and completing in-place density tests.

The on-site soils contain a significant amount of fines (silt) and are moisture-sensitive. Operation of equipment on these exposed soils will be difficult under wet conditions. Disturbance of shallow subgrade soils should be expected if subgrade preparation is completed on wet subgrade or during periods of wet weather.

### ***Structural Fill***

#### **MATERIALS**

Materials used as backfill at the site should meet the requirements below.

- Structural fill placed below structure areas should meet the requirements of WSDOT gravel borrow, per WSDOT Standard Specification 9-03.14(1). Recycled concrete may be substituted for this material, per WSDOT Standard Specification 9-03.21(1)C.
- Crushed rock base below utility slabs should consist of clean crushed aggregate with negligible sand or fines, or meet the requirements of WSDOT Standard Specification 9-03.9(3) with the exception that the fines content (material passing the U.S. No. 200 sieve) should not exceed 5 percent.

## REUSE OF ON-SITE SOILS

Medium dense fine-grained silty sand and sand with silt was encountered in our borings completed in the utility yard. This soil is suitable for foundation and slab support but can become easily disturbed due to the fines content. These soils will be suitable for re-use if they can be moisture conditioned to within 2 percent of the optimum moisture content required for compaction.

## FILL PLACEMENT AND COMPACTION CRITERIA

Structural fill should be mechanically compacted to a firm, non-yielding condition. Structural fill should be placed in loose lifts not exceeding 12 inches in thickness. Each lift should be conditioned to the proper moisture content and compacted to the specified density before placing subsequent lifts. The moisture content should not vary more than about two percent above or below the optimum moisture content (OMC). Structural fill should be compacted to the following criteria:

- Structural fill placed below foundations and utility slabs should be compacted to 95 percent of the MDD estimated in general accordance with ASTM D 1557.
- Structural fill in pavement areas, including utility trench backfill, should be compacted to 90 percent of the MDD estimated in general accordance with ASTM D 1557, except that the upper 2 feet of fill below final subgrade should be compacted to 95 percent of the MDD.
- Structural fill placed as crushed rock base course below pavements should be compacted to 95 percent of the MDD estimated in general accordance with ASTM D 1557.

We recommend that GeoEngineers be present during proof-rolling and/or probing of the exposed subgrade soils, and during placement of structural fill. We will evaluate the adequacy of the subgrade soils and identify areas needing further work, perform in-place moisture-density tests in the fill to verify compliance with the compaction specifications and advise on any modifications to the procedures that may be appropriate for the prevailing conditions.

## TEMPORARY CUT SLOPES

All temporary cut slopes and shoring must comply with the provisions of Title 296 Washington Administrative Code (WAC), Part N, "Excavation, Trenching and Shoring." The contractor performing the work has the primary responsibility for protection of workers and adjacent improvements.

We recommend temporary cut slope inclinations of 1.5H:1V in the native medium dense soils encountered at the site. Some raveling/sloughing of the cut slopes may occur at this inclination. The inclination may need to be flattened by the contractor if significant sloughing or seepage occurs. These cut slope recommendations apply to fully dewatered conditions. For open cuts at the site, we recommend that:

- No traffic, construction equipment, stockpiles or building supplies be allowed at the top of the cut slopes within a distance of at least 5 feet from the top of the cut.
- Exposed soil along the slope be protected from surface erosion using waterproof tarps or plastic sheeting.
- Construction activities be scheduled so that the length of time the temporary cut is left open is reduced to the extent practicable.

- Erosion control measures be implemented as appropriate such that runoff from the site is reduced to the extent practicable.
- Surface water be diverted away from the excavation.
- The general condition of the slopes should be observed periodically by GeoEngineers to confirm adequate stability.

Because the contractor has control of the construction operations, the contractor should be made responsible for the stability of cut slopes, as well as the safety of the excavations. The contractor should take all necessary steps to ensure the safety of the workers near slopes.

Where excavations could impact existing utilities, provisions for temporary support should be made by the contractor. We recommend that any excavation which extends under existing facilities or difficult access areas be backfilled with controlled-density fill (CDF).

## TEMPORARY SHORING

The installation of deeper excavations or utilities may require shoring to support temporary excavations and maintain the integrity of the surrounding soils, to reduce disruption of adjacent improvements and to protect the personnel working within the excavations.

Because of the diversity of available shoring systems and construction techniques, the design of temporary shoring is most appropriately left up to the contractor proposing to complete the installation. The following paragraphs present recommendations for the type of shoring systems and design parameters that we conclude are appropriate for the subsurface conditions at the project.

The site soils can be retained using conventional shoring systems such as trench boxes or slide rail systems. The design of temporary shoring should allow for lateral pressures exerted by the adjacent soil, and for surcharge loads resulting from structures, traffic, construction equipment, temporary stockpiles adjacent to the excavation, etc. Lateral load resistance can be mobilized through the use of braces, tiebacks, anchor blocks and passive pressures on members that extend below the bottom of the excavation. Temporary shoring used to support trench excavations typically uses internal bracing such as hydraulic shoring or trench boxes.

The lateral soil pressures acting on shoring walls will depend on the nature and density of the soil behind the wall and the inclination of the backfill surface. For walls that are free to yield at the top at least one thousandth of the height of the wall (i.e., wall height times 0.001), soil pressures will be less than if movement is restrained. We recommend that yielding walls retaining medium dense to dense fill and native soils be designed using an equivalent fluid density of 35 and 65 pcf, for horizontal ground surfaces and ground surfaces inclined at 1½ H:1V above the horizontal, respectively. For non-yielding (i.e., braced) systems, we recommend that the shoring be designed for a uniform lateral pressure of  $26 \cdot H$  in psf, where H is the depth of the planned excavation in feet below a level ground surface. Similarly, for a ground surface inclined at 1½H:1V above partial shoring, we recommend that shoring be designed for a uniform lateral pressure of  $46 \cdot H$ .

These lateral soil pressures do not include traffic, structure or construction surcharges that should be added separately, if appropriate. These soil pressure recommendations are predicated upon the construction being essentially dewatered; if effective dewatering methods are used to lower the groundwater level below the bottom of the excavation, hydrostatic pressures need not be added to the soil pressures within the exposed height of shoring.

If portions of the shoring use passive elements such as anchor or reaction blocks, available soil resistance can be estimated using passive soil pressures assuming an equivalent fluid density of 300 pcf above the water table and 150 pcf below the water table.

## Limitations

We have prepared this report for the exclusive use of the Benaroya Capital Company, LLC and members of the design team for the Centeris South Utility Yard project in Puyallup, Washington. The data and report should be provided to prospective contractors for their bidding or estimating purposes, but our report, conclusions and interpretations should not be construed as a warranty of the subsurface conditions.

Within the limitations of scope, schedule and budget, our services have been executed in accordance with generally accepted practices in the field of geotechnical engineering in this area at the time this report was prepared. No warranty or other conditions, express or implied, should be understood.

Any electronic form, facsimile or hard copy of the original document (email, text, table and/or figure), if provided, and any attachments are only a copy of the original document. The original document is stored by GeoEngineers, Inc. and will serve as the official document of record.

Please refer to Attachment B “Report Limitations and Guidelines for Use” for additional information pertaining to use of this report.

We appreciate the opportunity to provide continued services on the South Hill Business and Technology Center site. Please contact us if you have any questions or if you need additional information.

Sincerely,  
GeoEngineers, Inc.

  
Debra C. Overbay  
Associate Geotechnical Engineer



DC0:atk

### Attachments

Figure 1. Vicinity Map

Figure 2. Centeris South Utility Yard Borings

Attachment A. Field Explorations and Laboratory Testing

Attachment B. Report Limitations and Guidelines for Use One electronic copy submitted

Disclaimer: Any electronic form, facsimile or hard copy of the original document (email, text, table, and/or figure), if provided, and any attachments are only a copy of the original document. The original document is stored by GeoEngineers, Inc. and will serve as the official document of record.

## Figures

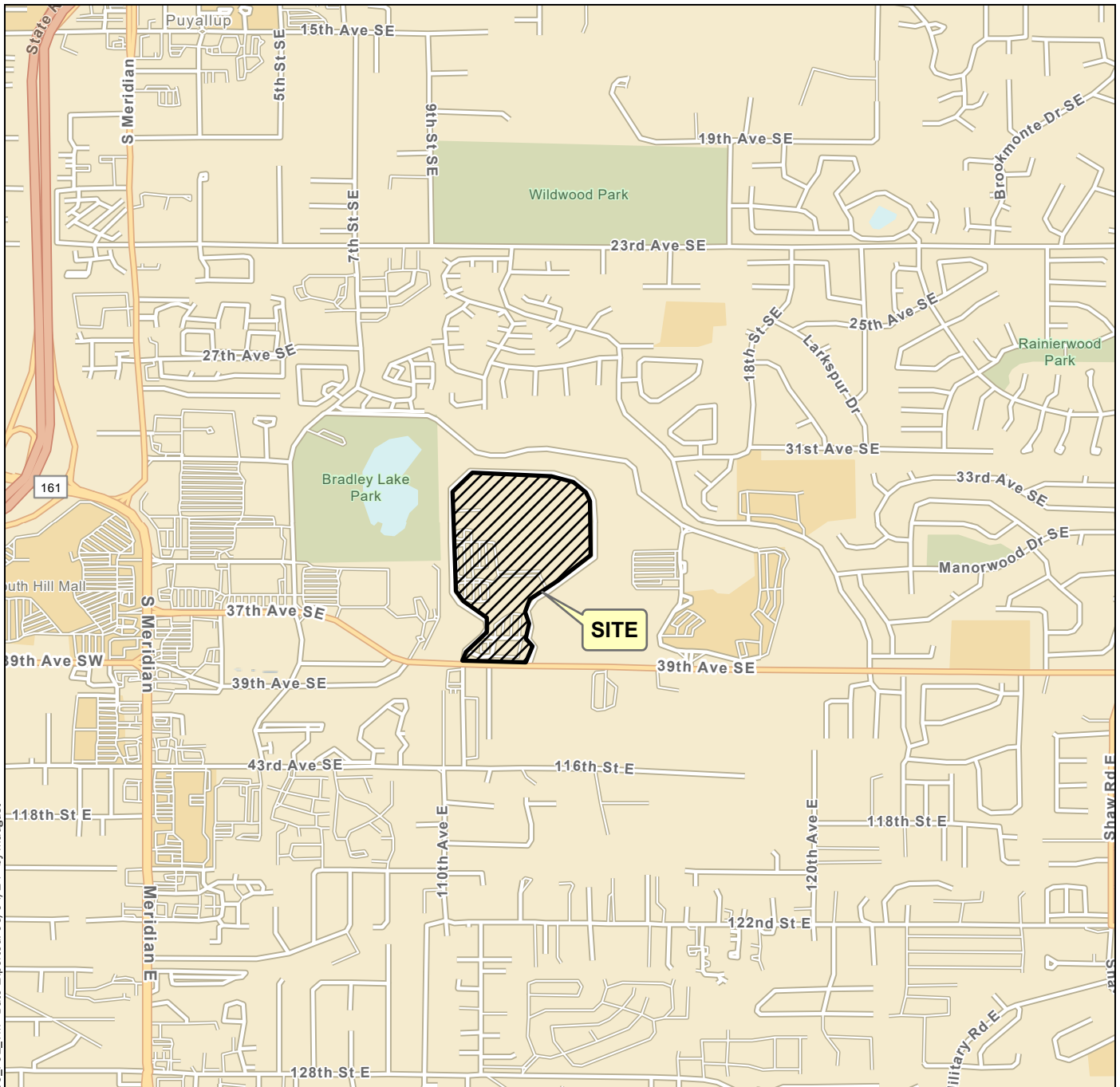

P:\4565064\06\_GIS\456506406\_Project.aprx 456506406\_Project.aprx 456506409\_F01\_VM Date Exported: 06/04/24 by maugust

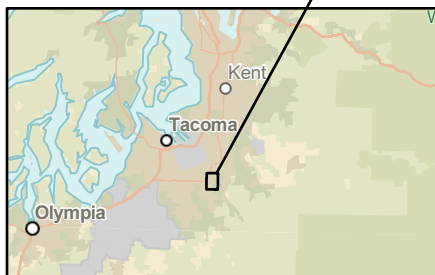

**Notes:**

1. The locations of all features shown are approximate.
2. This drawing is for information purposes. It is intended to assist in showing features discussed in an attached document. GeoEngineers, Inc. cannot guarantee the accuracy and content of electronic files. The master file is stored by GeoEngineers, Inc. and will serve as the official record of this communication.

Data Source: ESRI  
 Projection: NAD 1983 StatePlane Washington South FIPS 4602 Feet

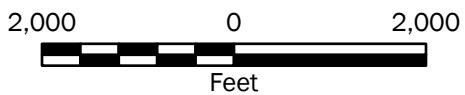

<b>Vicinity Map</b>	
Benaroya Capital Company, LLC South Hill Business & Technology Center Puyallup, Washington	
	<b>Figure 1</b>



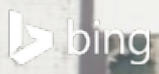

**Legend**

 Boring Completed by GeoEngineers, 2024

Source(s):  
• Bing Maps

Coordinate System: NAD 1983 StatePlane Washington South FIPS 4602 Feet

**Disclaimer:** This figure was created for a specific purpose and project. Any use of this figure for any other project or purpose shall be at the user's sole risk and without liability to GeoEngineers. The locations of features shown may be approximate. GeoEngineers makes no warranty or representation as to the accuracy, completeness, or suitability of the figure, or data contained therein. The file containing this figure is a copy of a master document, the original of which is retained by GeoEngineers and is the official document of record.

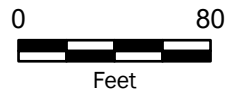

**Centeris South Utility Yard Borings**

Benaroya Capital Company, LLC  
South Hill Business & Technology Center  
Puyallup, Washington



**Figure 2**

## Appendices



**Attachment A**  
**Field Explorations and Laboratory Testing**

# Attachment A

## Field Explorations and Laboratory Testing

### FIELD EXPLORATIONS

Subsurface conditions at the site were explored on May 21, 2024 by drilling four borings (B-1 through B-4) at the approximate locations shown on the Site Plan (Figure 2). The approximate exploration locations were established in the field by measuring distances from existing site features. The borings were completed to depths of 161½ to 21½ feet below existing ground surface (bgs) using track mounted hollow-stem auger (HSA) drilling equipment owned and operated by Advance Drill Technologies, Inc. of Snohomish, Washington.

The borings were continuously monitored by a representative from our firm who examined and classified the soils encountered, obtained representative soil samples and observed groundwater conditions. Our representative maintained a detailed log of each boring. Disturbed samples of the representative soil types were obtained using a 2-inch outside-diameter Standard Penetration Test (SPT) split-spoon sampler.

The soils encountered in the borings were typically sampled at 5-foot vertical intervals with the SPT split-spoon sampler through the full depth of the explorations. SPT sampling was performed using a 2-inch outside diameter split-spoon sampler driven with a standard 140-pound autohammer in accordance with ASTM International (ASTM) D 1586. During the test, a sample is obtained by driving the sampler 18 inches into the soil with a hammer free-falling 30 inches. The number of blows required for each 6 inches of penetration is recorded. The SPT resistance (“N-value”) of the soil is calculated as the number of blows required for the final 12 inches of penetration (blows/foot). This resistance, or N-value, provides a measure of the relative density of granular soils and the relative consistency of cohesive soils. If the high penetration resistance encountered in the very dense soils precluded driving the total 18-inch sample interval, the penetration resistance for the partial penetration is entered on logs as follows: if the penetration is greater than 6 inches and less than 18 inches, then the number of blows is recorded over the number of inches driven; 30 blows for 6 inches and 50 for 3 inches, for instance, would be recorded as 80/9". The blow counts are shown on the boring logs at the respective sample depths. The SPT is a useful quantitative tool from which soil density/consistency was evaluated.

Soils encountered in the borings were classified in the field in general accordance with ASTM D 2488, the Standard Practice for Classification of Soils, Visual-Manual Procedure, which is summarized in Figure A-1, Key to Exploration Logs. The boring log symbols are also described in Figure A-1, and logs of the borings are provided in Figures A-2 through A-5. The borings were backfilled in accordance with Washington State Department of Ecology.

### GROUNDWATER CONDITIONS

Groundwater was not observed during drilling as noted on the exploration logs; these observations represent a short-term condition that may not be representative of the long-term groundwater conditions at the site. Groundwater conditions observed during drilling should be considered approximate.

## LABORATORY TESTING

Soil samples obtained from the explorations were transported to our laboratory and evaluated to confirm or modify field classifications, as well as to evaluate engineering properties of the soil samples. Representative samples were selected for laboratory testing consisting of moisture content testing, percent fines (material passing the U.S. No. 200 sieve), grain-size distribution (sieve analysis) and resistivity in general accordance with test methods of the ASTM or other applicable procedures.

## MOISTURE CONTENT TESTING

Moisture content tests were completed in general accordance with ASTM D 2216 for representative samples obtained from the borings. The results of these tests are presented on the boring logs at the depths at which the samples were obtained.

## PERCENT PASSING U.S. NO. 200 SIEVE (%F)

Selected samples were “washed” through the No. 200 mesh sieve to estimate the relative percentages of coarse and fine-grained particles in the soil. The percent passing value represents the percentage by weight of the sample finer than the U.S. No. 200 sieve. These tests were conducted to verify field descriptions and to estimate the fines content for analysis purposes. The tests were conducted in accordance with ASTM D 1140, and the results are shown on the exploration logs at the respective sample depths.

## SIEVE ANALYSES

Sieve analyses were performed on selected samples in general accordance with ASTM D 6913 to determine the sample grain size distribution. The wet sieve analysis method was used to determine the percentage of soil greater than the U.S. No. 200 mesh sieve. The results of the sieve analyses were plotted, classified in general accordance with the Unified Soil Classification System (USCS) and are presented in Figure A-6, Sieve Analysis Results.

## RESISTIVITY

Soil resistivity tests were completed on representative samples in accordance with ASTM G 187) The results of resistivity tests are shown below.

### RESISTIVITY TEST RESULTS

BORING	SAMPLE DEPTH (FEET)	VALUE (OHM-CM)
B-1	15	13,000
B-2	15	12,000
B-3	10	19,000
B-4	15	30,000

## SOIL CLASSIFICATION CHART

MAJOR DIVISIONS			SYMBOLS		TYPICAL DESCRIPTIONS
			GRAPH	LETTER	
COARSE GRAINED SOILS	GRAVEL AND GRAVELLY SOILS	CLEAN GRAVELS <small>(LITTLE OR NO FINES)</small>		<b>GW</b>	WELL-GRADED GRAVELS, GRAVEL - SAND MIXTURES
		GRAVELS WITH FINES <small>(APPRECIABLE AMOUNT OF FINES)</small>		<b>GP</b>	POORLY-GRADED GRAVELS, GRAVEL - SAND MIXTURES
	SAND AND SANDY SOILS	CLEAN SANDS <small>(LITTLE OR NO FINES)</small>		<b>GM</b>	SILTY GRAVELS, GRAVEL - SAND - SILT MIXTURES
				<b>GC</b>	CLAYEY GRAVELS, GRAVEL - SAND - CLAY MIXTURES
		SANDS WITH FINES <small>(APPRECIABLE AMOUNT OF FINES)</small>		<b>SW</b>	WELL-GRADED SANDS, GRAVELLY SANDS
				<b>SP</b>	POORLY-GRADED SANDS, GRAVELLY SAND
FINE GRAINED SOILS	SILTS AND CLAYS	LIQUID LIMIT LESS THAN 50		<b>ML</b>	INORGANIC SILTS, ROCK FLOUR, CLAYEY SILTS WITH SLIGHT PLASTICITY
				<b>CL</b>	INORGANIC CLAYS OF LOW TO MEDIUM PLASTICITY, GRAVELLY CLAYS, SANDY CLAYS, SILTY CLAYS, LEAN CLAYS
				<b>OL</b>	ORGANIC SILTS AND ORGANIC SILTY CLAYS OF LOW PLASTICITY
	SILTS AND CLAYS	LIQUID LIMIT GREATER THAN 50		<b>MH</b>	INORGANIC SILTS, MICACEOUS OR DIATOMACEOUS SILTY SOILS
				<b>CH</b>	INORGANIC CLAYS OF HIGH PLASTICITY
				<b>OH</b>	ORGANIC CLAYS AND SILTS OF MEDIUM TO HIGH PLASTICITY
HIGHLY ORGANIC SOILS				<b>PT</b>	PEAT, HUMUS, SWAMP SOILS WITH HIGH ORGANIC CONTENTS

NOTE: Multiple symbols are used to indicate borderline or dual soil classifications

### Sampler Symbol Descriptions

	Modified California Sampler (6-inch sleeve) or Dames & Moore
	Standard Penetration Test (SPT)
	Shelby tube
	Piston
	Direct-Push
	Bulk or grab
	Continuous Coring

Blowcount is recorded for driven samplers as the number of blows required to advance sampler 12 inches (or distance noted). See exploration log for hammer weight and drop.

"P" indicates sampler pushed using the weight of the drill rig.

"WOH" indicates sampler pushed using the weight of the hammer.

NOTE: The reader must refer to the discussion in the report text and the logs of explorations for a proper understanding of subsurface conditions. Descriptions on the logs apply only at the specific exploration locations and at the time the explorations were made; they are not warranted to be representative of subsurface conditions at other locations or times.

## ADDITIONAL MATERIAL SYMBOLS

SYMBOLS		TYPICAL DESCRIPTIONS
GRAPH	LETTER	
	<b>AC</b>	Asphalt Concrete
	<b>CC</b>	Cement Concrete
	<b>CR</b>	Crushed Rock/Quarry Spalls
	<b>SOD</b>	Sod/Forest Duff
	<b>TS</b>	Topsoil

### Groundwater Contact



Measured groundwater level in exploration, well, or piezometer



Measured free product in well or piezometer

### Graphic Log Contact



Distinct contact between soil strata



Approximate contact between soil strata

### Material Description Contact



Contact between geologic units



Contact between soil of the same geologic unit

### Laboratory / Field Tests

%F	Percent fines
%G	Percent gravel
AL	Atterberg limits
CA	Chemical analysis
CP	Laboratory compaction test
CS	Consolidation test
DD	Dry density
DS	Direct shear
HA	Hydrometer analysis
MC	Moisture content
MD	Moisture content and dry density
Mohs	Mohs hardness scale
OC	Organic content
PM	Permeability or hydraulic conductivity
PI	Plasticity index
PL	Point load test
PP	Pocket penetrometer
SA	Sieve analysis
TX	Triaxial compression
UC	Unconfined compression
UU	Unconsolidated undrained triaxial compression
VS	Vane shear

### Sheen Classification

NS	No Visible Sheen
SS	Slight Sheen
MS	Moderate Sheen
HS	Heavy Sheen

## Key to Exploration Logs



Figure A-1

Drilled	Start 5/21/2024	End 5/21/2024	Total Depth (ft)	16.5	Logged By Checked By	AAE DCO	Driller	GeoEngineers, Inc.	Drilling Method	Hollow-stem Auger	
Surface Elevation (ft) Vertical Datum		Undetermined NAVD88			Hammer Data		Autohammer 140 (lbs) / 30 (in) Drop		Drilling Equipment		D-50
Easting (X) Northing (Y)				System Datum		WA State Plane South NAD83 (feet)			Groundwater not observed at time of exploration		
Notes:											

Elevation (feet)	FIELD DATA					Graphic Log	Group Classification	MATERIAL DESCRIPTION	Moisture Content (%)	Fines Content (%)	REMARKS
	Depth (feet)	Interval Recovered (in)	Blows/foot	Collected Sample	Sample Name Testing						
0						SOD	Approximately 1 inch of sod				
						SM	Brown fine to medium sand with occasional gravel (medium dense, moist) (fill)				
5	9	41		1A 1B		SM	Brown fine to medium silty sand with gravel (dense, moist)	6	16		
10	12	47		2			Grades with increased gravel				
15	18	22		3 %F		SM	Light brown fine to medium silty sand (medium dense, moist)	16	26		

Note: See Figure A-1 for explanation of symbols.  
Coordinates Data Source: Horizontal approximated based on . Vertical approximated based on .

### Log of Boring B-1



Project: South Hill Business Park Centeris South Utility Yard  
Project Location: Puyallup, Washington  
Project Number: 4565-064-09

Figure A-2  
Sheet 1 of 1

Date: 6/13/24 Path: P:\4565064\GINT\_456506409.GPJ DBLibrary\Library\GEOENGINEERS\_DF\_STD\_US\_JUNE\_2017.GLB\GEI6\_GEO TECH\_STANDARD\_WF\_NO\_GW

Start Drilled	5/21/2024	End	5/21/2024	Total Depth (ft)	21.5	Logged By	AAE	Checked By	DCO	Driller	GeoEngineers, Inc.	Drilling Method	Hollow-stem Auger
Surface Elevation (ft) Vertical Datum	Undetermined NAVD88			Hammer Data	Autohammer 140 (lbs) / 30 (in) Drop			Drilling Equipment		D-50			
Easting (X) Northing (Y)				System Datum	WA State Plane South NAD83 (feet)			Groundwater not observed at time of exploration					
Notes:													

Elevation (feet)	FIELD DATA					Graphic Log	Group Classification	MATERIAL DESCRIPTION	Moisture Content (%)	Fines Content (%)	REMARKS
	Depth (feet)	Interval Recovered (in)	Blows/foot	Collected Sample	Sample Name Testing						
0						SOD	Approximately 1 inch of sod				
						SM	Brown silty sand with gravel (medium dense, moist) (fill)				
5	10	23		1 SA		SM	Brown fine to coarse silty sand with occasional gravel (medium dense, moist)				
10	14	40		2							
15	14	38		3			Grades with silt pockets				
20	14	8		4 %F				15	21		

Note: See Figure A-1 for explanation of symbols.  
Coordinates Data Source: Horizontal approximated based on . Vertical approximated based on .

### Log of Boring B-2



Project: South Hill Business Park Centeris South Utility Yard  
Project Location: Puyallup, Washington  
Project Number: 4565-064-09

Figure A-3  
Sheet 1 of 1

Date: 6/13/24 Path: P:\4565064\GINT\_456506\09.GPJ DBLibrary/Library\GEOENGINEERS\_DF\_STD\_US\_JUNE\_2017.GLB\GEB\_GEO TECH\_STANDARD\_WF\_NO\_GW

Drilled	Start 5/21/2024	End 5/21/2024	Total Depth (ft)	16.5	Logged By Checked By	AAE DCO	Driller	GeoEngineers, Inc.	Drilling Method	Hollow-stem Auger	
Surface Elevation (ft) Vertical Datum		Undetermined NAVD88			Hammer Data		Autohammer 140 (lbs) / 30 (in) Drop		Drilling Equipment		D-50
Easting (X) Northing (Y)				System Datum		WA State Plane South NAD83 (feet)		Groundwater not observed at time of exploration			
Notes:											

Elevation (feet)	FIELD DATA				Graphic Log	Group Classification	MATERIAL DESCRIPTION	Moisture Content (%)	Fines Content (%)	REMARKS
	Depth (feet)	Interval Recovered (in)	Blows/foot	Collected Sample Sample Name Testing						
0					SOD	Approximately 1 inch of sod				
					SM	Light brown fine to medium sand with silt and gravel (loose to medium dense, moist) (fill)				
					SP-SM	Brown-gray fine to medium sand with silt and occasional gravel and organic matter (fine roots) (medium dense, moist)				
5	16	12	1							
					SM	Brown fine to medium silty sand (dense, moist)	10	29		No recovery, re-sampled
10	0 14	45 29	2 %F							
15	18	24	3			Grades to medium dense				

Note: See Figure A-1 for explanation of symbols.  
Coordinates Data Source: Horizontal approximated based on . Vertical approximated based on .

### Log of Boring B-3



Project: South Hill Business Park Centeris South Utility Yard  
Project Location: Puyallup, Washington  
Project Number: 4565-064-09

Figure A-4  
Sheet 1 of 1

Date: 6/13/24 Path: P:\4565064\GINT\_456506\09.GPJ DBLibrary/Library\GEOENGINEERS\_DF\_STD\_US\_JUNE\_2017.GLB\GEB\_GEO TECH\_STANDARD\_WF\_NO\_GW

Drilled	Start 5/21/2024	End 5/21/2024	Total Depth (ft)	21.5	Logged By Checked By	AAE DCO	Driller	GeoEngineers, Inc.	Drilling Method	Hollow-stem Auger	
Surface Elevation (ft) Vertical Datum		Undetermined NAVD88			Hammer Data		Autohammer 140 (lbs) / 30 (in) Drop		Drilling Equipment		D-50
Easting (X) Northing (Y)				System Datum			WA State Plane South NAD83 (feet)		Groundwater not observed at time of exploration		
Notes:											

Elevation (feet)	FIELD DATA					Graphic Log	Group Classification	MATERIAL DESCRIPTION	Moisture Content (%)	Fines Content (%)	REMARKS
	Depth (feet)	Interval Recovered (in)	Blows/foot	Collected Sample	Sample Name Testing						
0						SOD	Approximately 1 inch of sod				
						SP-SM	Light brown sand with silt and gravel (loose, moist) (fill)				
5	4	7		1		SM	Light brown silty fine sand (loose, moist)				
10	9	25		2A 2B		SM	Brown fine to coarse silty sand with occasional gravel (medium dense, moist)	12			
15	18	15		SA				12	21		
20	18	33		4							

Note: See Figure A-1 for explanation of symbols.  
Coordinates Data Source: Horizontal approximated based on . Vertical approximated based on .

### Log of Boring B-4



Project: South Hill Business Park Centeris South Utility Yard  
Project Location: Puyallup, Washington  
Project Number: 4565-064-09

Figure A-5  
Sheet 1 of 1

Date: 6/13/24 Path: P:\4565064\GINT\_456506\09.GPJ DBLibrary\Library\GEOENGINEERS\_DF\_STD\_US\_JUNE\_2017.GLB\GEB\_GEO TECH\_STANDARD\_WF\_NO\_GW



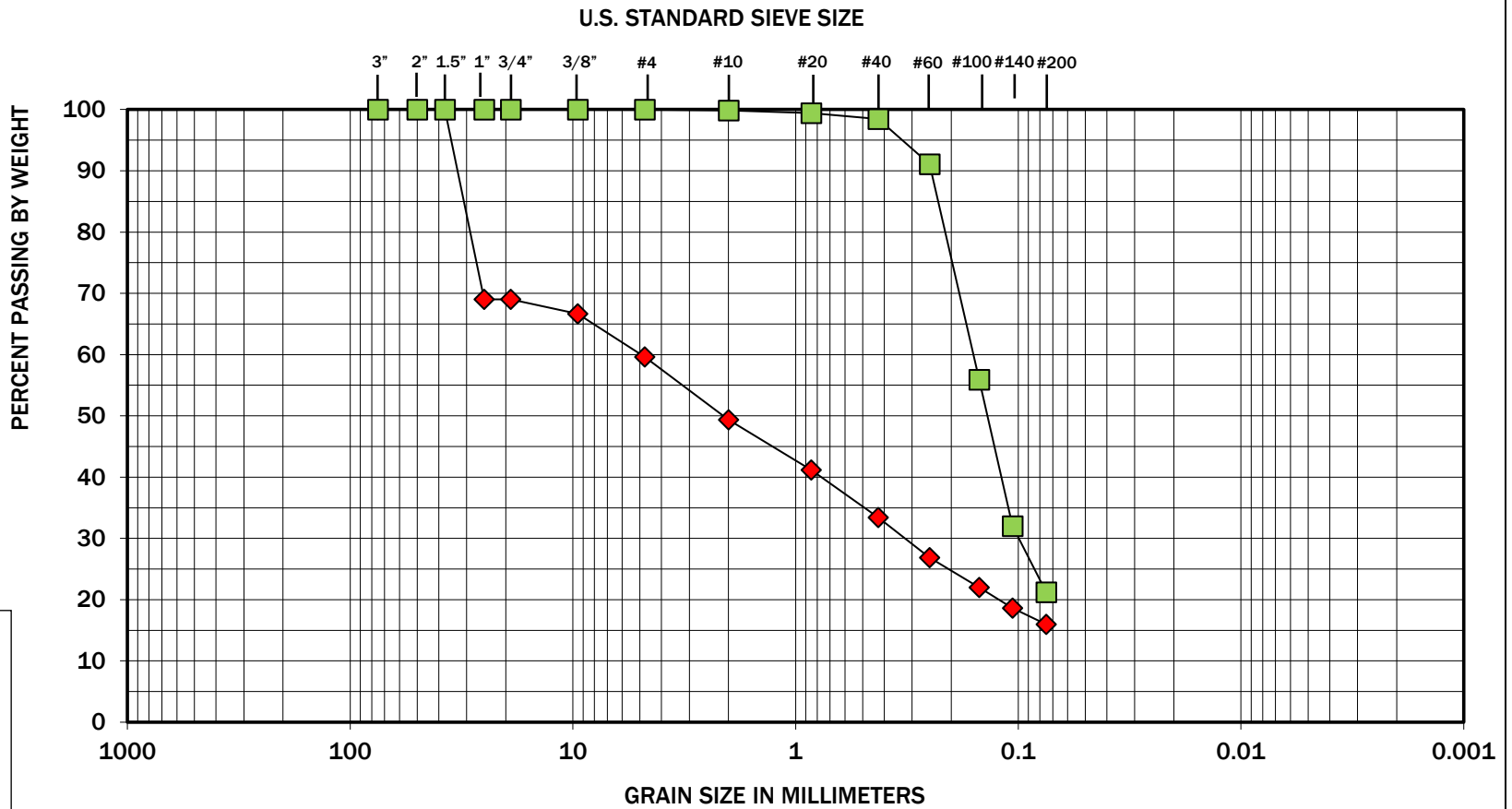

COBBLES	GRAVEL		SAND			SILT OR CLAY
	COARSE	FINE	COARSE	MEDIUM	FINE	

Symbol	Boring Number	Depth (feet)	Moisture (%)	Soil Description
◆	B-1	5	6	Silty sand with gravel (SM)
■	B-4	15	12	Silty sand (SM)

**GEOENGINEERS**

Benaroya South Hill  
Puyallup, Washington

Sieve Analysis Results

Figure-A-6



Note: This report may not be reproduced, except in full, without written approval of GeoEngineers, Inc. Test results are applicable only to the specific sample on which they were performed, and should not be interpreted as representative of any other samples obtained at other times, depths or locations, or generated by separate operations or processes.

The grain size analysis results were obtained in general accordance with ASTM D6913. GeoEngineers 17425 NE Union Hill Road Ste 250, Redmond, WA 98052

**Attachment B**  
**Report Limitations and Guidelines for Use**

## Attachment B

### Report Limitations and Guidelines for Use<sup>1</sup>

This attachment provides information to help you manage your risks with respect to the use of this report.

#### *Read These Provisions Closely*

It is important to recognize that the geoscience practices (geotechnical engineering, geology, and environmental science) rely on professional judgment and opinion to a greater extent than other engineering and natural science disciplines, where more precise and/or readily observable data may exist. To help clients better understand how this difference pertains to our services, GeoEngineers includes the following explanatory “limitations” provisions in its reports. Please confer with GeoEngineers if you need to know more how these “Report Limitations and Guidelines for Use” apply to your project or site.

#### *Geotechnical Services Are Performed for Specific Purposes, Persons, and Projects*

This report has been prepared for the Benaroya Capital Company, LLC and for the Project(s) specifically identified in the report. The information contained herein is not applicable to other sites or projects.

GeoEngineers structures its services to meet the specific needs of its clients. No party other than the party to whom this report is addressed may rely on the product of our services unless we agree to such reliance in advance and in writing. Within the limitations of the agreed scope of services for the Project, and its schedule and budget, our services have been executed in accordance with our Agreement with the Benaroya Capital Company, LLC dated April 5, 2023 and generally accepted geotechnical practices in this area at the time this report was prepared. We do not authorize, and will not be responsible for, the use of this report for any purposes or projects other than those identified in the report.

#### *A Geotechnical Engineering or Geologic Report is Based on a Unique Set of Project-Specific Factors*

This report has been prepared for the Centeris South Utility Yard project in Puyallup, Washington. GeoEngineers considered a number of unique, project-specific factors when establishing the scope of services for this project and report. Unless GeoEngineers specifically indicates otherwise, it is important not to rely on this report if it was:

- Not prepared for you,
- Not prepared for your project,
- Not prepared for the specific site explored, or
- Completed before important project changes were made.

---

<sup>1</sup> Developed based on material provided by GBA, GeoProfessional Business Association; [www.geoprofessional.org](http://www.geoprofessional.org).

For example, changes that can affect the applicability of this report include those that affect:

- The function of the proposed structure;
- Elevation, configuration, location, orientation or weight of the proposed structure;
- Composition of the design team; or
- Project ownership.

If important changes are made after the date of this report, GeoEngineers should be given the opportunity to review our interpretations and recommendations and provide written modifications or confirmation, as appropriate.

### ***Subsurface Conditions Can Change***

This geotechnical or geologic report is based on conditions that existed at the time the study was performed. The findings and conclusions of this report may be affected by the passage of time, by man-made events such as construction on or adjacent to the site, new information or technology that becomes available subsequent to the report date, or by natural events such as floods, earthquakes, slope instability or groundwater fluctuations. If more than a few months have passed since issuance of our report or work product, or if any of the described events may have occurred, please contact GeoEngineers before applying this report for its intended purpose so that we may evaluate whether changed conditions affect the continued reliability or applicability of our conclusions and recommendations.

### ***Geotechnical and Geologic Findings Are Professional Opinions***

Our interpretations of subsurface conditions are based on field observations from widely spaced sampling locations at the site. Site exploration identifies the specific subsurface conditions only at those points where subsurface tests are conducted or samples are taken. GeoEngineers reviewed field and laboratory data and then applied its professional judgment to render an informed opinion about subsurface conditions at other locations. Actual subsurface conditions may differ, sometimes significantly, from the opinions presented in this report. Our report, conclusions and interpretations are not a warranty of the actual subsurface conditions.

### ***Geotechnical Engineering Report Recommendations Are Not Final***

We have developed the following recommendations based on data gathered from subsurface investigation(s). These investigations sample just a small percentage of a site to create a snapshot of the subsurface conditions elsewhere on the site. Such sampling on its own cannot provide a complete and accurate view of subsurface conditions for the entire site. Therefore, the recommendations included in this report are preliminary and should not be considered final. GeoEngineers' recommendations can be finalized only by observing actual subsurface conditions revealed during construction. GeoEngineers cannot assume responsibility or liability for the recommendations in this report if we do not perform construction observation.

We recommend that you allow sufficient monitoring, testing and consultation during construction by GeoEngineers to confirm that the conditions encountered are consistent with those indicated by the explorations, to provide recommendations for design changes if the conditions revealed during the work differ from those anticipated, and to evaluate whether earthwork activities are completed in accordance with our recommendations. Retaining GeoEngineers for construction observation for this project is the most effective means of managing the risks associated with unanticipated conditions. If another party performs field observation and confirms our expectations, the other party must take full responsibility for both the observations and recommendations. Please note, however, that another party would lack our project-specific knowledge and resources.

Misinterpretation of this report by members of the design team or by contractors can result in costly problems. GeoEngineers can help reduce the risks of misinterpretation by conferring with appropriate members of the design team after submitting the report, reviewing pertinent elements of the design team's plans and specifications, participating in pre-bid and preconstruction conferences, and providing construction observation.

### *Give Contractors a Complete Report and Guidance*

To help reduce the risk of problems associated with unanticipated subsurface conditions, GeoEngineers recommends giving contractors the complete geotechnical engineering or geologic report, including these "Report Limitations and Guidelines for Use." When providing the report, you should preface it with a clearly written letter of transmittal that:

- Advises contractors that the report was not prepared for purposes of bid development and that its accuracy is limited; and
- Encourages contractors to conduct additional study to obtain the specific types of information they need or prefer.

### *Contractors Are Responsible for Site Safety on Their Own Construction Projects*

Our geotechnical recommendations are not intended to direct the contractor's procedures, methods, schedule, or management of the work site. The contractor is solely responsible for job site safety and for managing construction operations to minimize risks to on-site personnel and adjacent properties.