



PRPL20241606

SSB-728-09

4107 9501 62.04

Page 1 of 5

29 November 2023

Full-Sized legible color report is required to be provided by the Permittee on site for all Inspections

O2 QUAD VSD SPC
BASE MOUNT

Lifeline® "Oil-Less" O₂ Assured Claw Medical Vacuum Base Mount Single Point Connection (SPC) Quadruplex System with Variable Speed Drive (5 Hp – 8.7 Hp)

SPECIFICATION

Single Point Connection (SPC) System Design

The LifeLine® Oil-Less Claw Medical vacuum package is fully compliant with NFPA 99 and features a common base with single point connections for the electrical panel, intake, and discharge. Each pump and the receiver are connected to a common intake manifold. Each pump is connected to a common discharge manifold. The common base is separable for transport through standard 34.5" doorway. Designed and manufactured with ISO 13485 processes, each system is completely tested before shipment and includes:

- Four "oil-less" O₂ Assured claw rotary vacuum pumps with four motors
- Integral pre-wired control panel with variable speed drive inverter
- Vertical air receiver with full-size three-valve bypass system sized for appropriate demand

Vacuum Pump

Each pump is a direct driven, non-contacting claw type, capable of operating continuous duty at the following levels:

- 5.4 Hp at 28.4" Hg (sea level)
- 6.4 and 7.5 Hp at 27" Hg (sea level)
- 8.7 Hp at 25.5" Hg (sea level)

The pumping chamber is oil free. The pump is completely aircooled with no water requirements. Each pump contains:

- Vacuum relief valve
- Check valve to prevent backflow through off-cycle units
- Flexible connector and isolation valve
- High discharge temperature sensor
- Oil drain valve and oil sight glass

Vacuum Pump Motor

Motors are continuous duty, C-face, TEFC, suitable for 230/460 or 208V, 60 hertz, 3-phase electrical service and 380V, 50 hertz, 3-phase electrical service.

Vacuum Filtration Per NFPA 99

A HEPA inlet air filter, 0.3 micron, 99.97% efficiency, is mounted before each vacuum pump. A clear, glass collection canister is mounted below each HEPA filter, with quarter turn valve to isolate canister from filter during service. The inlet filter canister contains a bleed valve to relieve vacuum before servicing.

Intake Piping

Each vacuum pump has a factory piped intake with integral flex connector, isolation valve, and check valve. Interconnecting piping consists of powder-coated steel tubing and flanges.

Vacuum Receiver

The vacuum receiver is ASME Code stamped, and rated for a minimum 150 PSIG design pressure. The receiver has a full-size three-valve bypass system to allow for draining of the receiver without interrupting the vacuum service. A manual drain is provided on the receiver.

Exhaust Piping

Each vacuum pump is factory piped to an exhaust manifold with integral flex connector and drip leg with ball valve and condensate drain. Interconnecting piping consists of powdercoated steel tubing and flanges. An exhaust muffler is shipped loose.

TotalAlert 360 Control System

The quadruplex mounted and wired TotalAlert 360 control system is U.L. labeled. The control system provides automatic lead/lag sequencing and automatic alternation of all vacuum pumps based on first-on/first-off principle with provision for simultaneous operation if required. Automatic activation of reserve unit, if required, will activate an audible alarm as well as a visual alarm on the display screen.

Additional components include:

- NEMA 12 control panel enclosure
- Single variable speed drive inverter
- Circuit breaker disconnects for each motor with external operators
- Full voltage motor starters with overload protection
- 24V control circuit
- 65kAIC SCCR rating for control cabinet

The touch screen controls feature a 10" color, high resolution screen. Screen displays and functions include:

- Easy to read system vacuum level and VSD speed
- Status of all units (Running, Available, Off, next to Run)
- Trend graphs for vacuum level, VSD speed, and units running
- Run time hour meters for each unit
- Visual/audible alarm indications with isolated contacts for all standard remote alarms
- Event log recording alarms and system activity
- Service alerts
- Event log recording service warnings and service history
- Integral cellular connectivity to MyMedGas, allowing electronic notifications of alarms and warnings
- Daily rounds uploadable to MyMedGas
- BTL listed, BACnet/IP communication

Oxygen Compatibility

The O₂ Assured vacuum pump is assembled and tested in a clean room with dedicated tools. All parts in contact with the flow stream, gear casing, and bearing surfaces are cleaned with oxygen compatible cleaner. The lubricant in the gear casing as well as the grease used to lubricate the bearings is a special oxygen compatible formula.

- Safe for all WAGD applications.
- Each vacuum pump is capable of operating safely with up to 60% oxygen content in the compression chamber.

Installation

The installation of this vacuum technology is limited to 4,000 feet elevation above sea level. For installation of this equipment above this elevation, please contact the factory.

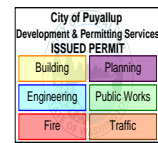

PRPL20241606

SSB-728-09

4107 9501 62.04

Page 3 of 5

29 November 2023

TotalAlert 360 Control System

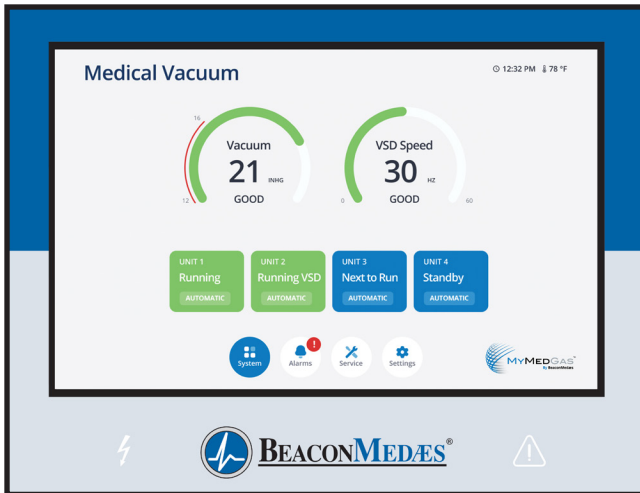

TotalAlert 360 10" Touch Screen

- 10" LCD 1280 x 800 Capacitive Touch Display for exceptional clarity and visibility, with enhanced user experience
- LCD is IPS-TFT for enhanced color and contrast, featuring 85% viewing angle in all directions
- Toolbars on all screens with easy access navigation icons that enable full access with minimal touches

MyMedGas Connectivity

- Cellular connectivity to cloud-based MyMedGas web page for remote operator to view system controls and display information
 - » View remotely system operation details, alarms and event history
 - » View remotely maintenance timers, service history logs
 - » Easily download system trends, event logs and reports for system management and record keeping
- Electronic notification
 - » Allows for remote alerts of alarm and warning conditions
 - » Allows for remote alerts of routine maintenance
- Logging rounds to MyMedGas
 - » Main screen touchpoint for MyMedGas with time stamp to log operating conditions, system parameters during daily rounds
 - » Automated report generated to MyMedGas

Ethernet Connectivity

- Control panel contains Ethernet port on top of cabinet for easy installation of BACnet
- TCP/IP protocol for BACnet activation
- Ethernet port on side of control cabinet that allows reprogramming with a standard computer for software updates

Control Cabinet Safety

- Volt free relay contacts for all standard alarms
- Low voltage (24V) control circuit
- Full voltage motor starters with overload protection
- Circuit breaker disconnects for each compressor
- 65kAIC SCCR rating

Redundancy

- Each vacuum pump has an individual board for control allowing units to function independently
- In unlikely malfunction of display board or display screen, system will function normally and activate alarm
- If master board malfunctions, system goes to failsafe operation with backup vacuum switch
- Independent LED indicators on control screen for Reserve in Use and power to the control panel as backup annunciation to display failure

Master Display Screen

- Main Screen
 - » Displays the system operating conditions, including system vacuum level and variable speed drive speed
 - » Displays the pump unit sequence, including status of pumps (running, available, off) and next to start
- Trends & Graphs
 - » Shows measured values of the system operating conditions over a period of time (vacuum level, VSD speed, and ambient temperature)
 - » Shows unit usage and operation, clearly identifying each unit and its running status
 - » Selectable time periods consist of 60 minutes, 4 hours, 24 hours, and 6 days
 - » Visually precise with green and red shading for normal and non-normal areas
- Service
 - » Displays ambient temperature in the room
 - » Maintenance screen shows suggested and required maintenance items with resettable timers
 - » Historical event log records all service activities
 - » Link to operations manuals associated with system
- Alarms and Shutdowns
 - » All system/unit Alarms and Shutdowns displayed with visual indication (Green or Red) and unit operation status, allowing for quick identification and evaluation of system operation
 - » Custom messaging for each alarm and shutdown
 - » Testing mode enables operator to test all alarm/shutdown events (password protected), with all test events recorded in the event log
 - » Event History Log records all system event history
- Unit Operation
 - » Screens show the operation mode of the unit along with automatic or manual mode setting
 - » Unit status screen displays the running hour meter values, including average daily run time and average starts/hour
 - » Pump rotation allows the unit to run for a short period to check pump rotation
- System Settings
 - » Allows the adjustment of system pressure operating range
 - » Displays pertinent system model information

Standard Configuration

8.7 Hp Quadruplex

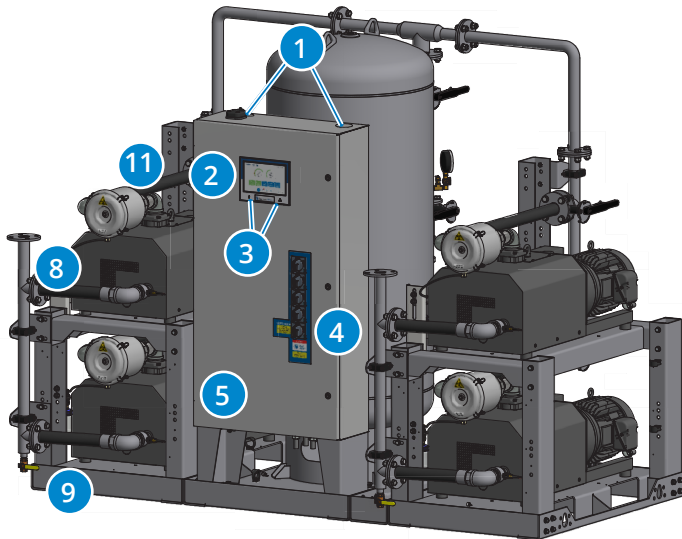

1 Control panel pre-drilled for power and alarms for easy electrical installations. Ethernet connection on panel top for easy installation of BACnet connectivity, with additional connection on the side panel for software updates.

2 TotalAlert 360 controls featuring 10" color screen with high resolution 1280 x 800 Capacitive Touch Display for exceptional clarity, visibility, and useability.

3 LED indication of Reserve in Use condition as backup annunciation to display failure and LED indication of power to the control panel.

4 Through the door disconnects for pumps and VSD inverter add to safety during service.

5 Control cabinet components achieve rating of 65kAIC SCCR.

6 Vacuum switch as backup to vacuum transducer. In case of transducer failure, system operates effectively.

7 Full-size 3-valve receiver bypass with flanged valves reduce potential leak points over NPT fittings.

8 Discharge manifold with a single point connection to the exhaust piping, with flex hoses factory installed.

9 Factory installed exhaust drip leg with ball valve and condensate drain.

10 Flex connectors on vacuum inlet and discharge to isolate pump vibration from facility pipeline.

11 Individual HEPA air inlet filter per vacuum pump to prevent contaminants from entering vacuum pump, ensuring safety during servicing. Housing bleed valve to remove vacuum for filter replacement.

12 Glass collection canister mounted below HEPA filter, with isolation valve to allow for easy changeout.

13 Easy to disassemble for transport through doorways and reassemble as Single Point Connection for installation.

14 Openings in base frame to allow access underneath pumps for pump maintenance.

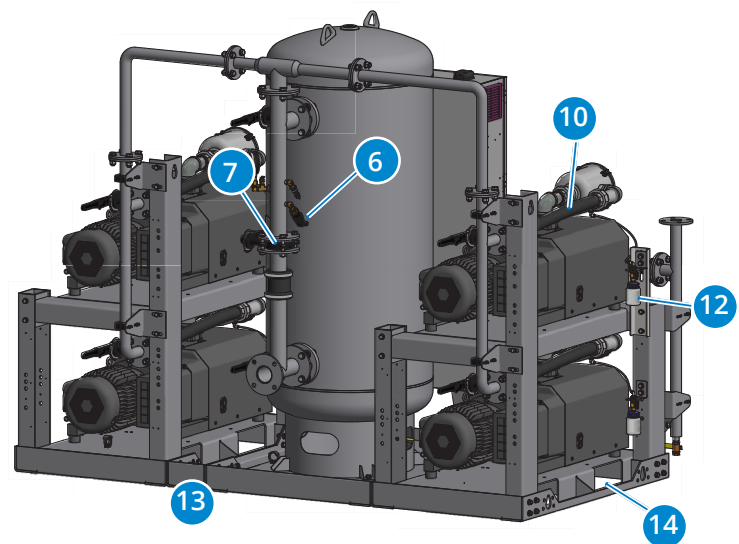

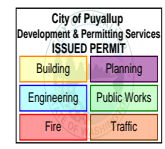

PRPL20241606

SSB-728-09
4107 9501 62.04
Page 4 of 5
29 November 2023

SPECIFICATION TABLE

Vacuum System Specifications ¹										
System Model No.	HP	Capacity ² @19" Hg (scfm)		System ³ BTU/Hr	Receiver (gallons)	Noise ⁴ Level	System FLA			System Weight (lbs)
		Pump	System				208V	230V	460V	
SPC Quadruplex - 60 Hz										
VAS06Q-200V-Q_V	6.4	52	156	39,091	200	89	72.4	71.3	36.0	4,455
VAS06Q-240V-Q_V	6.4	52	156	39,091	240	89	72.4	71.3	36.0	4,530
VAS07Q-200V-Q_V	7.5	65	195	45,199	200	89	99.6	80.9	40.8	4,471
VAS07Q-240V-Q_V	7.5	65	195	45,199	240	89	99.6	80.9	40.8	4,546
VAS08Q-200V-Q_V	8.7	77	231	53,140	200	92	103.2	98.5	49.6	4,511
VAS08Q-240V-Q_V	8.7	77	231	53,140	240	92	103.2	98.5	49.6	4,576
SPC Quadruplex - 50 Hz							380V			
VAS06Q-200V-QEV	6.4	43	129	39,091	200	89	39.6			4,455
VAS06Q-240V-QEV	6.4	43	129	39,091	240	89	39.6			4,530
VAS07Q-200V-QEV	7.5	54	162	45,199	200	89	42.8			4,471
VAS07Q-240V-QEV	7.5	54	162	45,199	240	89	42.8			4,546
VAS08Q-200V-QEV	8.7	64	192	53,140	200	92	53.2			4,511
VAS08Q-240V-QEV	8.7	64	192	53,140	240	92	53.2			4,576

Specification Table Notes:

1. Normal operating conditions at a maximum ambient of 105° F. Consult factory for higher ambient conditions.
2. All capacities are shown as NFPA 99 system capacities (reserve vacuum pump on standby).
3. All system BTU/HR are shown with reserve vacuum pump on standby.
4. All noise levels are shown in dB(A) and reflect reserve pump on standby.

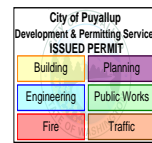

PRPL20241606

SSB-728-09
4107 9501 62.04
Page 5 of 5
29 November 2023

Standard Configuration

8.7 Hp Quadruplex

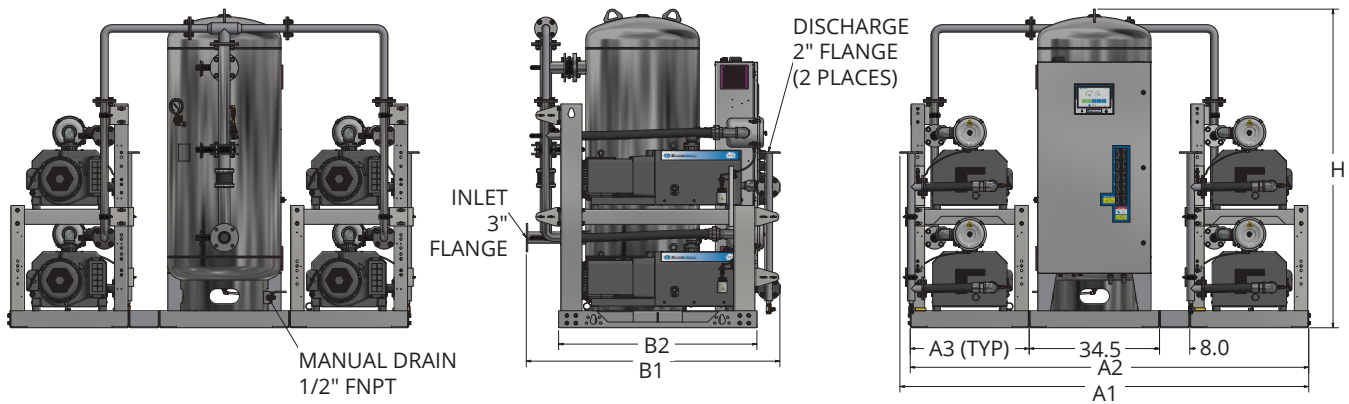
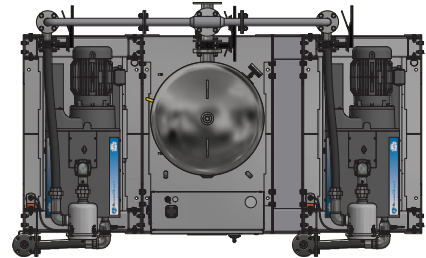

System Model No.	HP	Dimensions					
		A1 (Length)	A2 (Length)	A3 (Length)	B1 (Width)	B2 (Width)	H (Height)
VAS06Q-200V-Q_V	6.4	108.23	105.5	31.5	67.14	52.5	84.35
VAS06Q-240V-Q_V	6.4	108.23	105.5	31.5	66.84	52.5	96.34
VAS07Q-200V-Q_V	7.5	108.23	105.5	31.5	67.15	52.5	84.35
VAS07Q-240V-Q_V	7.5	108.23	105.5	31.5	67.15	52.5	96.34
VAS08Q-200V-Q_V	8.7	108.23	105.5	31.5	67.14	52.5	84.35
VAS08Q-240V-Q_V	8.7	108.23	105.5	31.5	67.15	52.5	96.34

Notes:

- Discharge muffler ships loose
- Allow 36 inches in front of control panel for maintenance and ventilation, all other sides require 24 inches of clearance.
- Additional drawings/diagrams available for download at www.beaconmedaes.com.

Life is in the details.®



1059 Paragon Way
Rock Hill, SC 29730
Phone: (803) 817-5600
www.beaconmedaes.com