

**A** SECTION 3/4" = 1'-0"

**B** SECTION 3/4" = 1'-0"

**C** SECTION 3/4" = 1'-0"

**D** SECTION 3/4" = 1'-0"

**E** SECTION 3/4" = 1'-0"

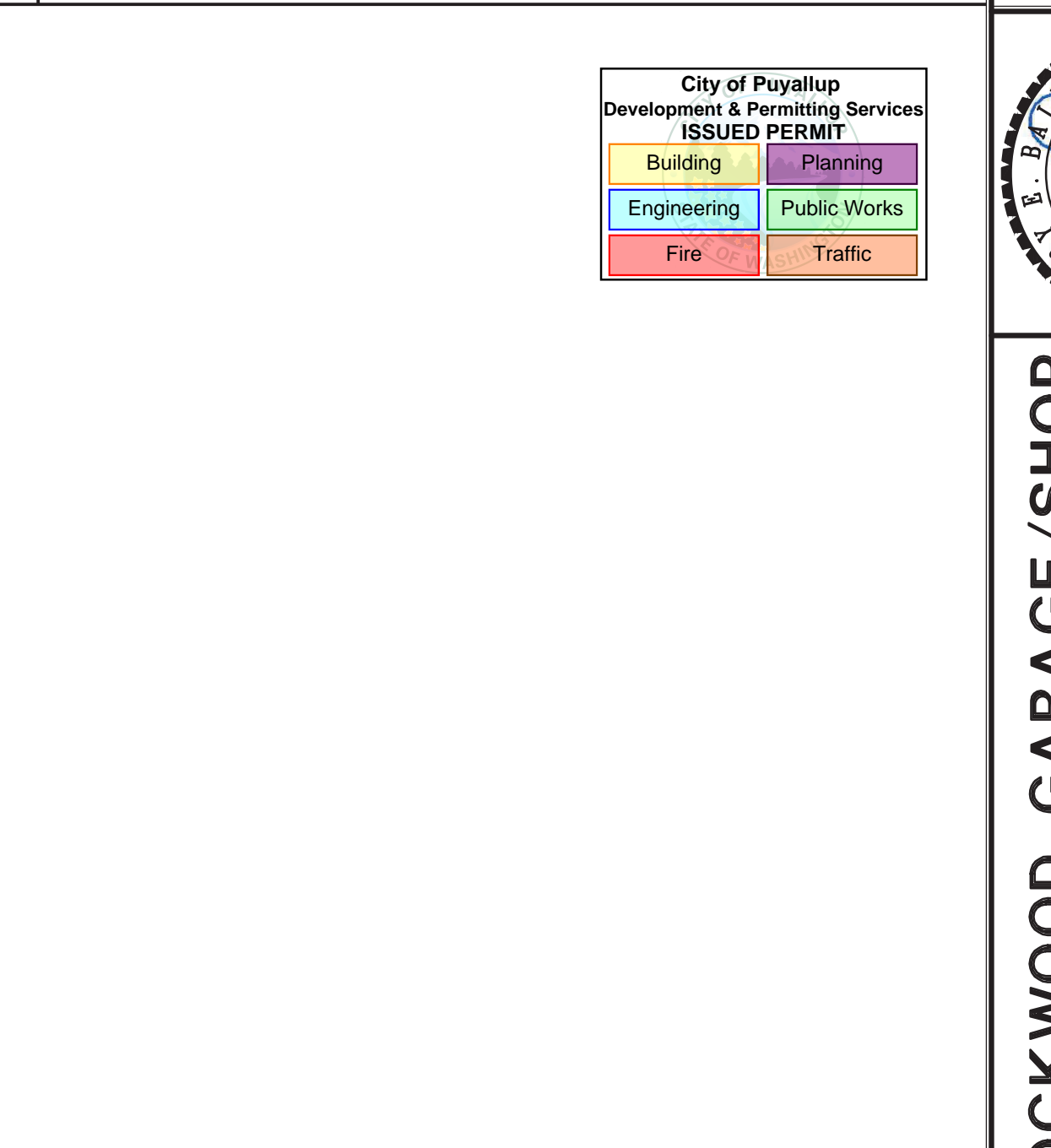
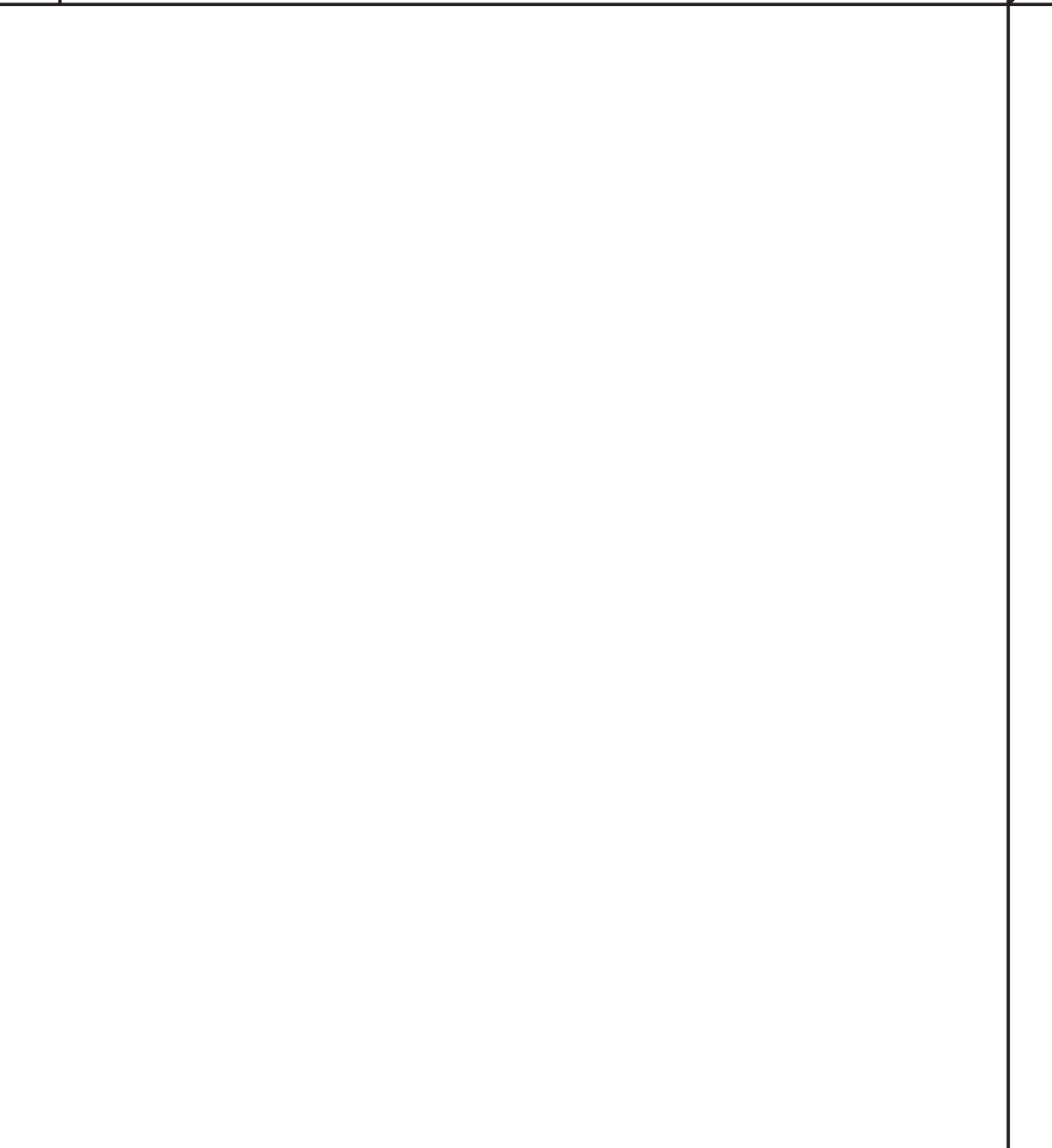
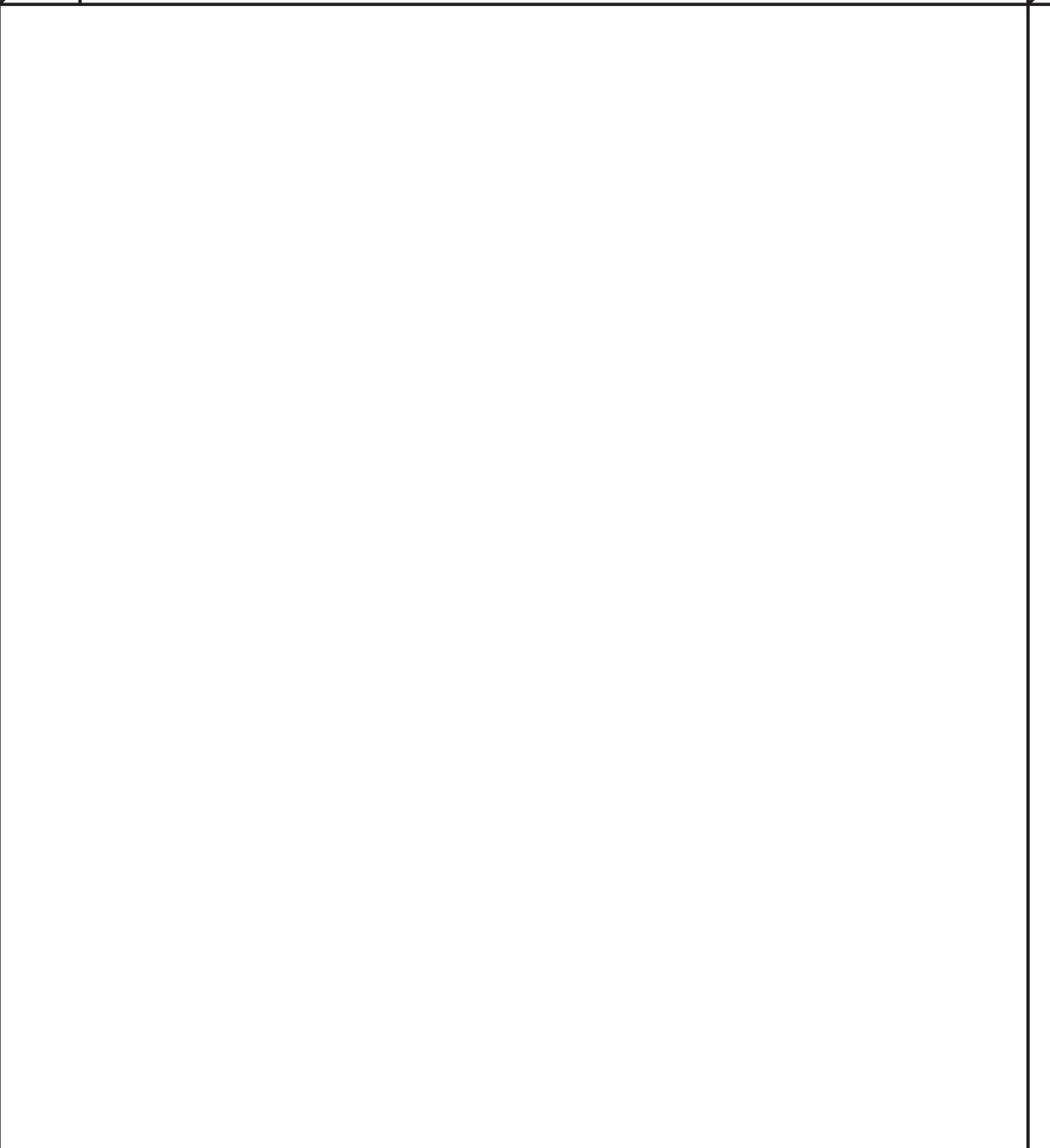
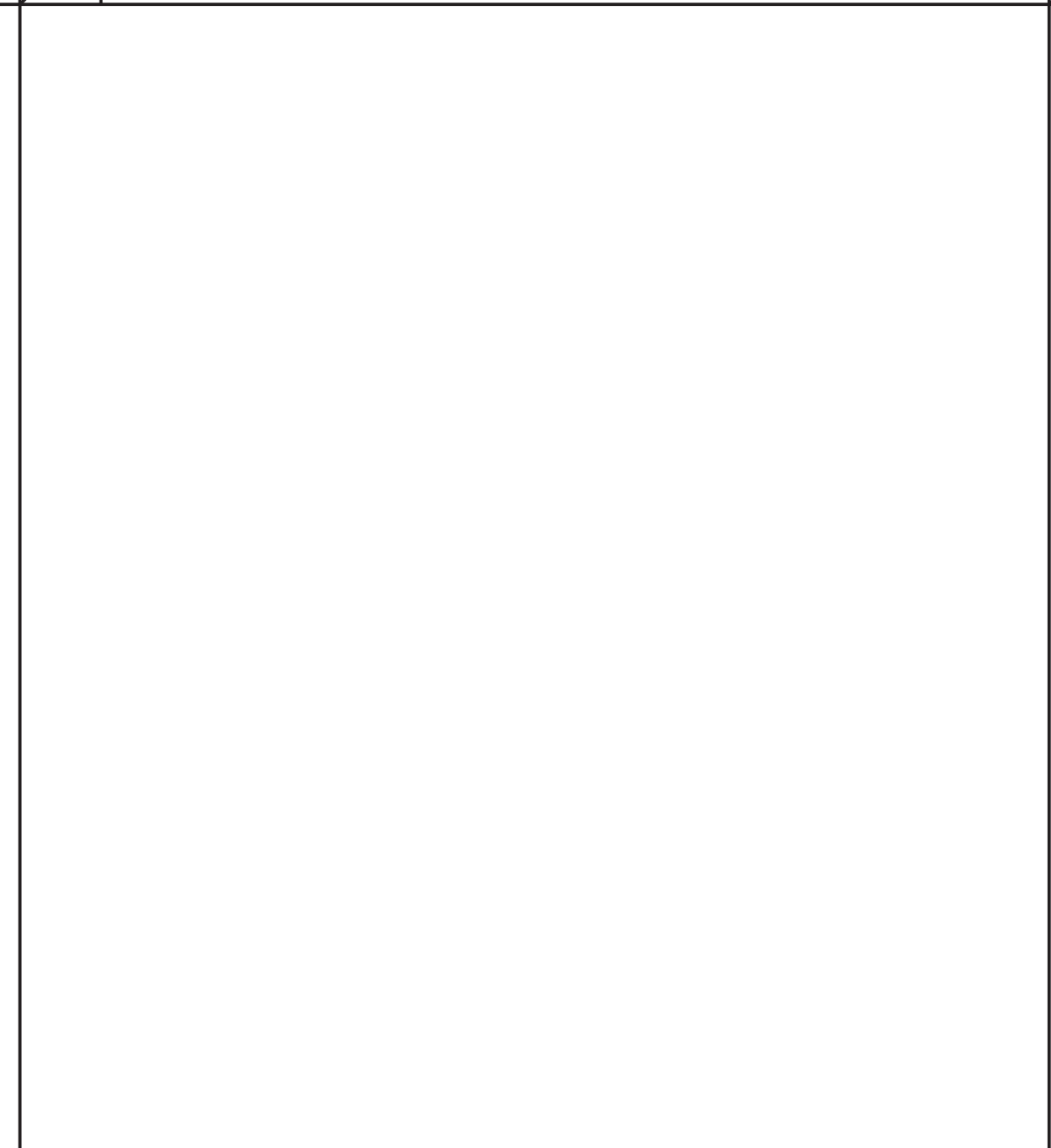
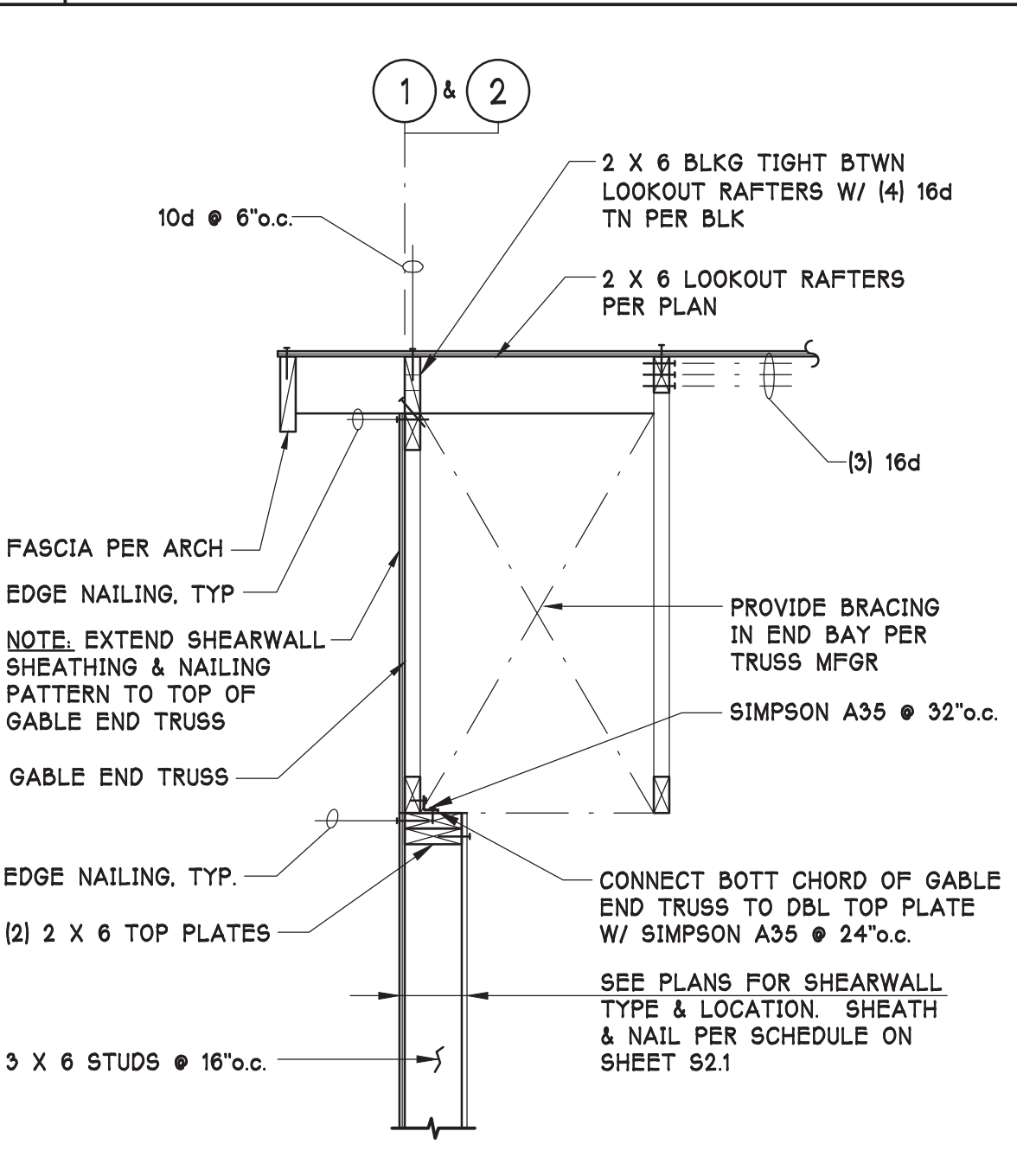

**F** SECTION 3/4" = 1'-0"

SECTION 3/4" = 1'-0"

SECTION 3/4" = 1'-0"

SECTION 3/4" = 1'-0"

SECTION 3/4" = 1'-0"

| REVISIONS | DATE | DESCRIPTION |
|-----------|------|-------------|
|           |      |             |
|           |      |             |
|           |      |             |

**PRGA20241682**

B & T DESIGN & ENGINEERING, INC.  
 2901 L. SUNSET WAY  
 SUITE 100  
 PUYALLUP, WA 98371  
 (253) 857-0770 (PHONE)  
 (253) 857-0766 (FAX)

**B&T**  
 DESIGN &  
 ENGINEERING

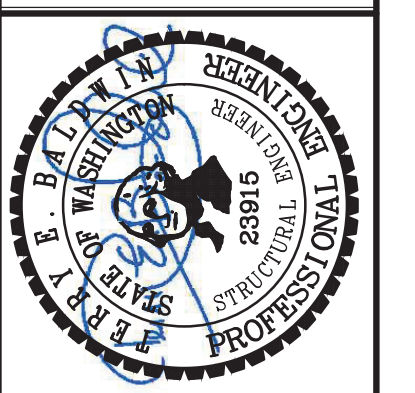

**LOCKWOOD GARAGE / SHOP**  
**3305 S FRUITLAND AVE**  
**PUYALLUP, WA 98373**

PROJECT TITLE

FOUNDATION  
 DETAILS

SHEET TITLE

|         |             |
|---------|-------------|
| PROJECT | 24056       |
| DATE    | 10/17/24    |
| DRAWN   | NH          |
| CHKD.   | JT          |
| SHEET : | <b>S3.1</b> |
| OF      |             |