

# BA-475B\* 1/4"-4"

**Brass Ball Valve  
Two Piece  
Full Port  
600 WOG (1/4"-3") 400 WOG (4")  
Threaded Ends  
Blow-Out Proof Stem  
MSS SP-110, ASME A112.4.14**



**PRMH20241875**



## MATERIALS LIST

ITEM	PART	MATERIALS	ASTM SPEC.
1	Body	Brass, Forged	B283
2	Tailpiece	Brass, Forged	B283
3	Ball	CP Brass (1/4" - 1 1/4")	B283
		CP Brass, Cast (1 1/2" - 4")	B584
4	Ball Seal	PTFE	Commercial
5	Stem	Brass	B124
6	O-Ring	Buna-N	D2006
7	Thrust Washer	PTFE	Commercial
8	Gland Nut	Brass	B16
9	Packing	PTFE	Commercial
10	Handle	Zinc Plated Steel	Commercial
11	Handle Nut	Zinc Plated Steel	Commercial
12	Body Seal (4" Only)	PTFE	Commercial

**\*Not intended for use in potable water.**

### CSA Listed (1/2" - 2")

- Class 3371-08: ANSI Z21.15/CSA 9.1, 1/2 psi
- Class 3371-12: CGA CR91-002, 5 psi
- Class 3371-88: ANSI Z21.15/CSA 9.1, 1/2 psi
- Class 3371-92: ASME B16.44, 5 psi

### UL Listed (1/4" - 2")

- UL 842 (YRPV) Gas Shutoff
  - UL 842 (MHKZ / MHKZ7) Manual Valves
  - UL 842 (YRBX7) Flammable Liquid Shutoff
  - UL 125 (YSDT / YSDT7) LP-Gas Shutoff
  - UL 1477 (YQNZ / YQNZ7) Compressed Gas Shutoff
  - UL 258 (VQGU) Trim and Drain Valves
- Note the suffix '7' refers to certification for Canada*

### FM Approved (1/4" - 2")

- FM 1140, 600 psi

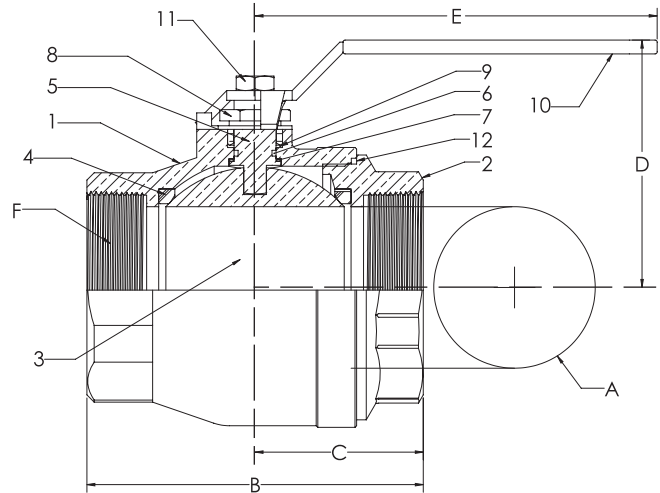
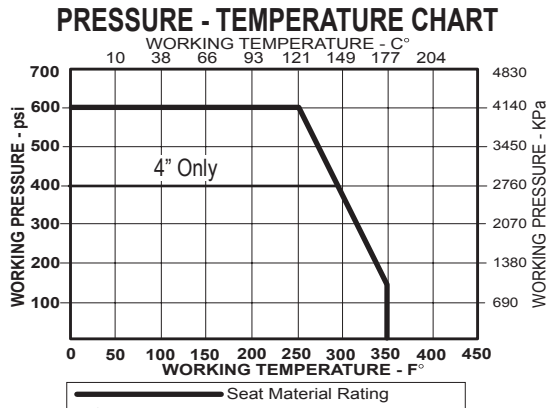

## DIMENSIONS

	UNITS	1/4"	3/8"	1/2"	3/4"	1"	1-1/4"	1-1/2"	2"	2-1/2"	3"	4"
A (DIA)	INCHES	0.39	0.39	0.51	0.76	1.00	1.26	1.50	2.00	2.48	2.95	3.94
	mm	10	10	13	19	25	32	38	51	63	75	100
B	INCHES	1.87	1.87	2.25	2.62	3.06	3.50	3.75	4.38	5.16	6.00	8.20
	mm	47	47	57	67	78	89	95	111	131	152	208
C	INCHES	0.95	0.95	1.12	1.31	1.52	1.73	1.87	2.19	2.58	3.00	4.11
	mm	24	24	28	33	39	44	47	56	66	76	104
D	INCHES	1.42	1.42	1.46	1.93	2.10	2.33	2.52	2.96	3.94	4.37	5.93
	mm	36	36	37	49	53	59	64	75	100	111	151
E	INCHES	3.27	3.27	3.27	4.45	4.45	5.24	5.24	7.01	7.87	7.87	9.65
	mm	83	83	83	113	113	133	133	178	200	200	245
F	THREAD SIZE	1/4" NPT	3/8" NPT	1/2" NPT	3/4" NPT	1" NPT	1-1/4" NPT	1-1/2" NPT	2" NPT	2-1/2" NPT	3" NPT	4" NPT
	Cv	12	12	18	40	72	112	161	287	307	323	584

The information presented on this sheet is correct at time of publication. Milwaukee Valve reserves the right to change design and/or materials without notice. For our Installation, Operation and Maintenance Manual and the most current product information go to [www.milwaukeevalve.com](http://www.milwaukeevalve.com).  
 ⚠ State of California Prop 65 **WARNING: Cancer and Reproductive Harm.** For more information visit [www.p65warnings.ca.gov](http://www.p65warnings.ca.gov).

