



PRCTI20241741

Submittal Package

Centeris

Project - Centeris Data Center -
1250kW Generator Submittal

Attn: Jeff Nordberg
(206) 596-5181

jnordberg@burkeelectric.com

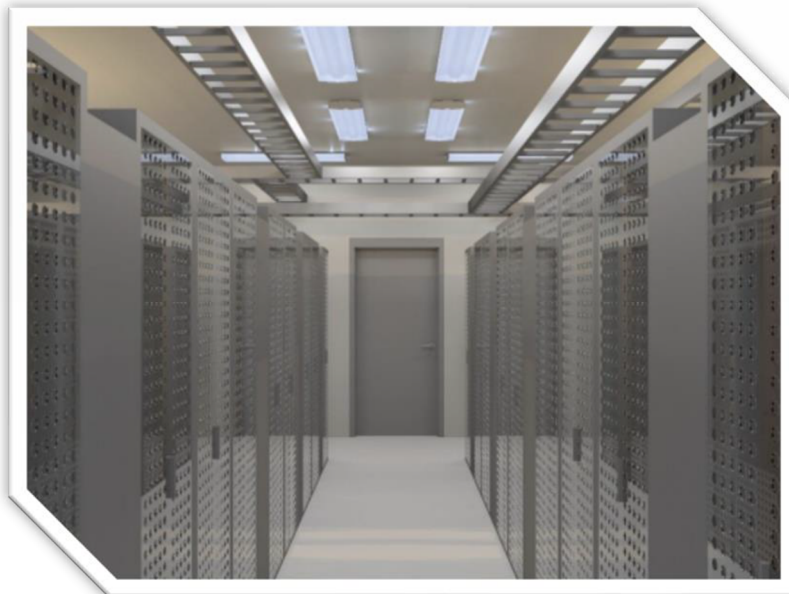

Revision 6

9/13/2024

City of Puyallup Development & Permitting Services ISSUED PERMIT	
Building	Planning
Engineering	Public Works
Fire	Traffic

<u>Item</u>	<u>Manufacturer</u>	<u>Model #</u>
Gravity Discharge Damper	Greenheck	EM-31
Motorized Control Dampers	Greenheck	VCD-43
Door Operating Handle	Kason	778/48
Silencer	Custom	Custom
Normal Vent	Morrison Brothers	354-0300AV
Emergency Vent	Clay & Bailey	366
Fuel Level Gauge	Kruger	H-2
Fuel Alarm Level Switches	Madison	M-7000
Leak Sensor	Pneumercator	LS-600
Overfill Prevention Valve	Morrison Brothers	9095AA-0300AV
Fuel Polishing System	Reverso	AFP-600
30kVA 480:120/208 Transformer	Hammond	SG3A0030KB
60A Fused Disconnect Switch	Square D	H362N
Panel Board MCB, 3-Phase, 4-Wire, 30 Slot	Square D	NQ430L2C & NQMB2Q
Interior 48" AC Lights LED	Halco	HLVT4/4OU50
Light Switches 3 Way - White	Legrand	PS20AC3W
GFI Duplex Receptacle - White	Legrand	2097TRW

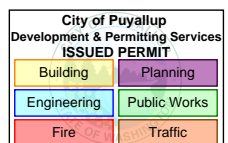

Space Heater	Dayton	3UG73
Skirtboard	Rubber Cal	70A
Stairs and Platforms	Coastline	Custom
Enclosure & Tank Drawings	Coastline	20240161-1-5

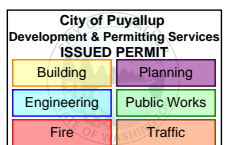



Greenheck Fan Corporation certifies that the models EM-30, EM-31 and EM-32 shown herein is licensed to bear the AMCA Seal. The ratings shown are based on tests and procedures performed in accordance with AMCA Publication 511 and comply with the requirements of the AMCA Certified Ratings Program. The AMCA Certified Ratings Seal applies to Air Leakage and Air Performance Ratings.

Test Information

- Air leakage is based on operation between 32°F and 120°F (0°C and 48°C)
- Tests for air leakage were conducted in accordance with ANSI/AMCA Standard 500-D Figure 5.5, in the intake direction
- Air performance testing conducted in accordance with ANSI/AMCA Standard 500-D, Figure 5.5

Air Leakage

Model EM-30 series dampers with a width and height 24 in. (610mm) or greater leak a maximum of:

- 8.9 cfm/ft² or less at 1.0 inches w.g.

Model EM-30 series dampers with a width or height less than 24 in. (610mm) leak a maximum of:

- 35 cfm/ft² or less at 1.0 inches w.g.

*Note: This model complies with the International Energy Conservation Code (IECC) and ASHRAE 90.1 leakage requirements for non-motorized dampers.

Air Performance

Performance data results from testing a 24 in. x 24 in. damper in accordance with AMCA Standard 500-D using Figure 5.5. All data has been corrected to represent standard air at 0.075 lb/ft³ (1.201 kg/m³).

Pressure Drop

24 in. x 24 in. Damper
(610mm x 610mm)

VELOCITY VS. PRESSURE DROP

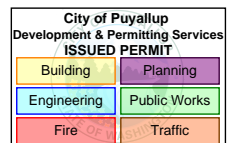
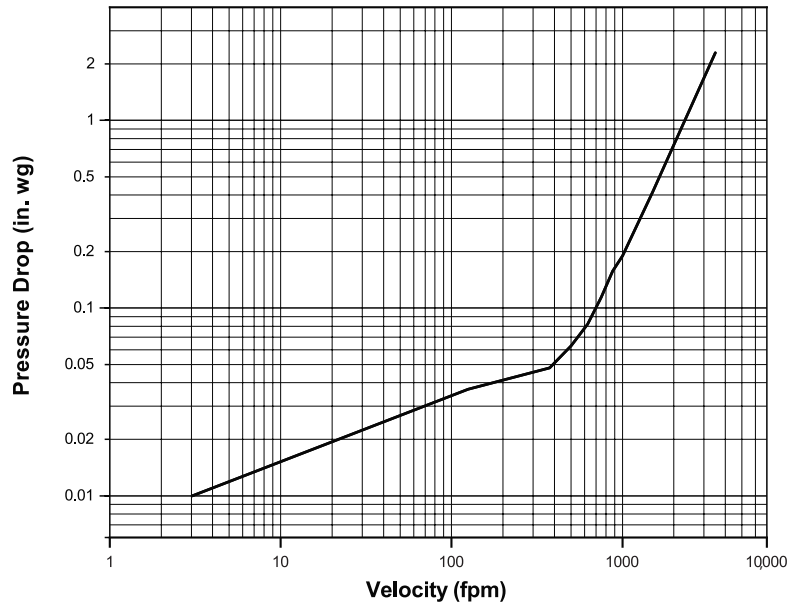

Velocity Limitations

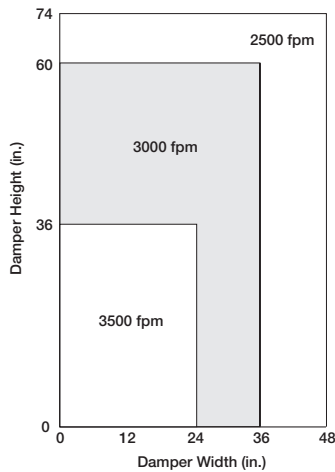

Operational Data (AMCA Figure 5.3)	ΔP in. wg (Pa)	
	Without Weights	With Weights
Blades Start to Open	0.03 (7.5)	0.01 (2.5)
Blades Fully Open	0.25 (62)	0.055 (13.7)

Operational Data (AMCA Figure 5.5)	ΔP in. wg (Pa)	
	Without Weights	With Weights
Blades Start to Open	0.025 (6.2)	0.01 (3)
Blades Fully Open	0.32 (8)	0.08 (20)

Specifications

Backdraft dampers meeting the following specifications shall be furnished and installed where shown on plans and/or as described in schedules.

Dampers shall consist of: heavy gauge 6063T5 extruded aluminum channel frame (0.125 in. [3.2mm] thick) with 3 1/8 in. (79mm) depth; blades from 0.070 in. (1.8mm) 6063T5 extruded aluminum; synthetic acetal axle bearings; damper shall be equipped with extruded vinyl blade seals; and internal 1/8 in. (3mm) plated steel

blade-to-blade linkage. Damper manufacturer's printed application and performance data including pressure, velocity and temperature limitations shall be submitted for approval showing damper suitable for pressures to 10 in. wg (2.5 kPa), velocities to 3500 fpm (18 m/s) and temperatures to 180°F (82°C). Testing and ratings to be in accordance with AMCA Standard 500-D.

Basis of design is model EM-30.

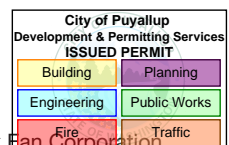



Model VCD-43

Extruded Airfoil Blade Control Damper

Low Leakage

Aluminum Frame Construction

Application and Design

The VCD-43 is a low leakage damper with extruded aluminum airfoil blades and frame. Smooth profile extruded aluminum airfoil blades insure the lowest resistance to airflow in HVAC systems. This model is intended for application in medium to high pressure and velocity systems.

VCD-43 is IECC (International Energy Conservation Code) compliant with a leakage rating of 3 cfm/ft² at 1 in. wg (55 cmh/m² at .25 kPa) or less.

Damper Ratings (See page 4 for specific limitations)

Pressure: Up to 8 in. wg (2 kPa) - pressure differential
For pressures greater than 8 in wg, consult factory.

Velocity: Up to 6000 fpm (30.5 m/s)

Leakage: Class 1A at 1 in. wg (0.25 kPa)
Class 1 at 4 - 8 in. wg (1 kPa - 2 kPa)

Temperature: -40°F to 250°F (-40°C to 121°C)



*W&H dimension furnished approximately 1/4 in. (6mm) undersize.

Construction	Standard	Optional
Frame Material	Aluminum	-
Frame Material Thickness	0.125 in. (3.2mm)	-
Frame Type	5 in. x 1 in. (127mm x 25mm) hat channel	Single Flange, Reverse Flange or Quick Connect
Blade Material	Extruded Aluminum	-
Blade Type	Airfoil	-
Blade Action	Opposed	Parallel
Linkage	Plated steel out of airstream, concealed in jamb	316SS
Axle Bearings	Synthetic (acetal) sleeve	316SS
Axle Material	Plated steel	316SS
Blade Seals	TPE	Silicone
Jamb Seals	Stainless Steel	-
Finish	Mill finish	Baked Enamel, Hi Pro Polyester, Industrial Epoxy, Kynar/Hylar (70%), Anodize

Blade Operation

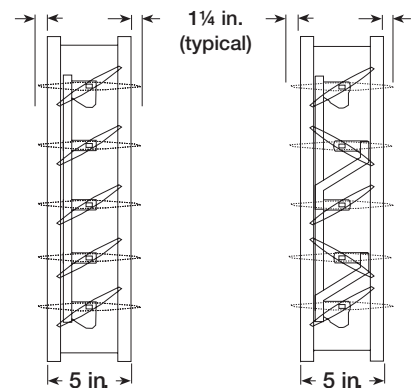

Parallel Blades

Opposed Blades

Size Limitations

in. (mm) W x H		Frame Type		
		Channel	Quick Connect	Single or Reverse Flange
Minimum Sizes*		8 x 6 (203 x 178)	8 x 5 (203 x 127)	8 x 6 (203 x 178)
Maximum Sizes	Single Section	60 x 74 (1524 x 1880)		
	Multiple Section	288 x 222 (7315 x 5639)	144 x 148 (3658 x 3759)	288 x 222 (7315 x 5639)

* varies by actuator

Installation instructions available at www.greenheck.com

Features:

- Low profile head and sill are used on sizes less than 17 in. high (432mm), excluding quick connect frame.
- Airfoil (streamlined) blade shape for reduced turbulence and lower pressure drop at velocities to 6000 fpm (30.5 m/s).
- Electric actuators and manual operators available. Factory installation available.
- Blades must be horizontal for either horizontal or vertical mount.
- If you need vertical blades, see VCD-43

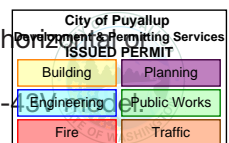

Frame Type Options

VCD-43

Channel Frame

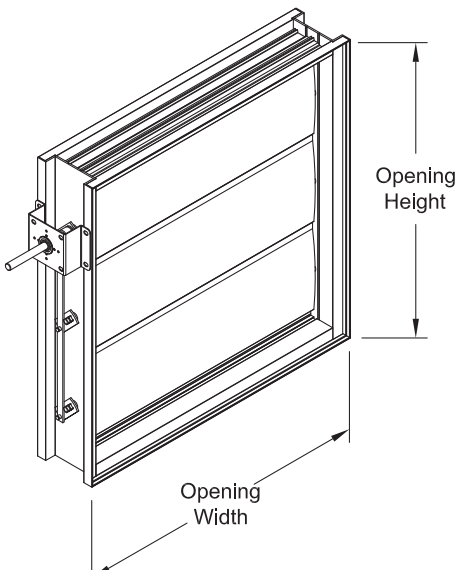

Single Flange

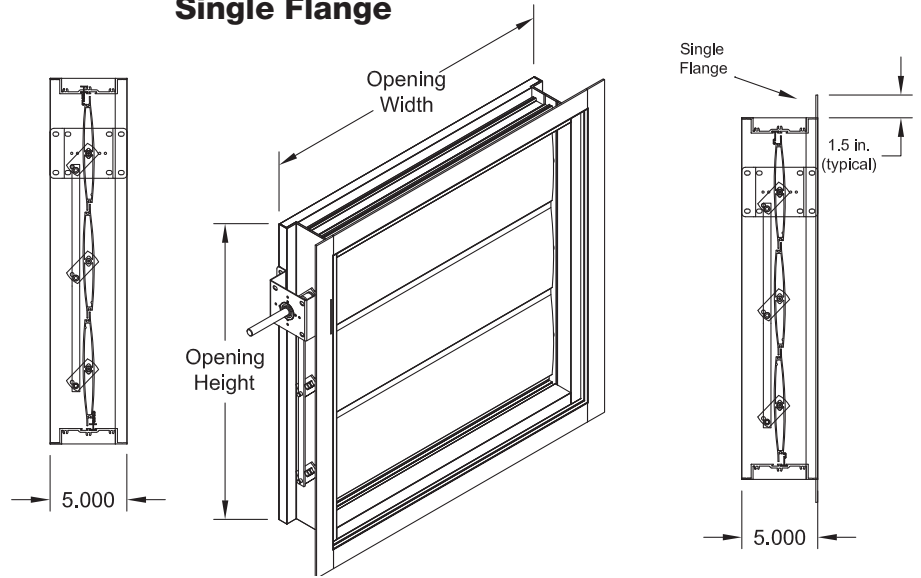

Reverse Flange

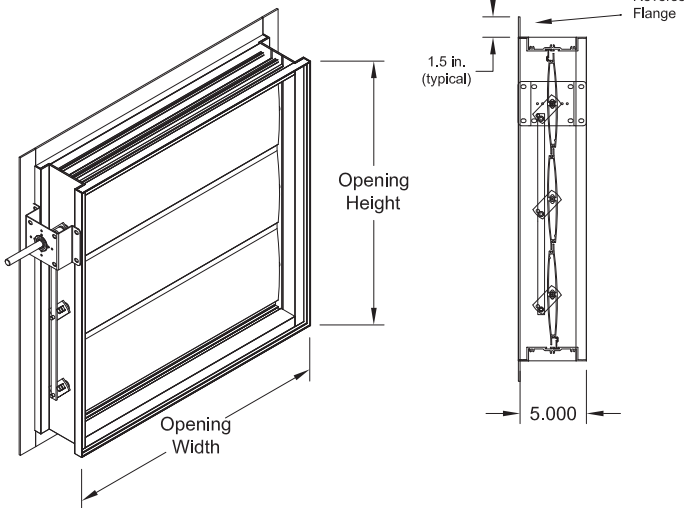

* Width and height is based on outside dimension. W & H dimensions furnished approximately 1/4 in. (6mm) undersize.

Quick Connect

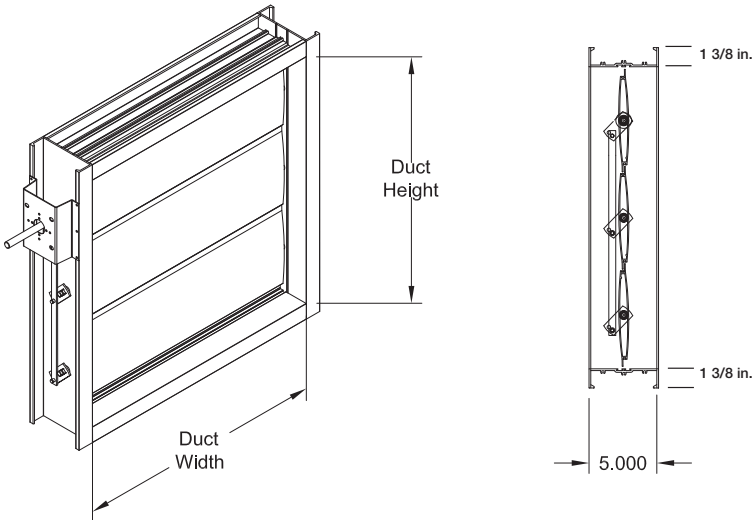

Note: When ordering the Quick Connect Frame, size is based on duct size (or inside dimension of the damper frame). Quick connect frame is actual size.

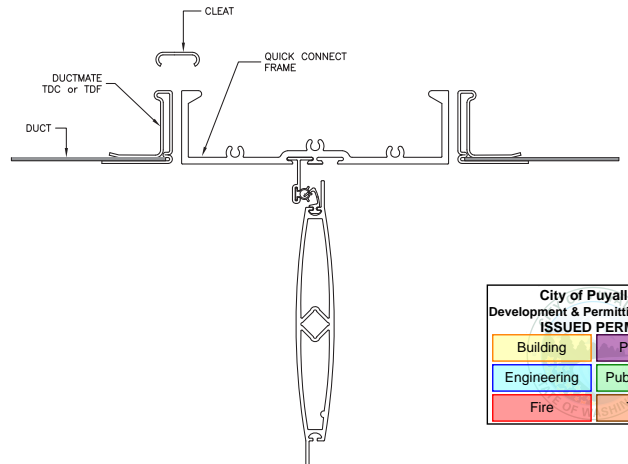

City of Puyallup Development & Permitting Services ISSUED PERMIT	
Building	Planning
Engineering	Public Works
Fire	Traffic

This pressure drop testing was conducted in accordance with AMCA Standard 500-D using the three configurations shown. All data has been corrected to represent standard air at a density of .075 lb/ft³ (1.2 kg/m³).

Actual pressure drop found in any HVAC system is a combination of many factors. This pressure drop information along with an analysis of other system influences should be used to estimate actual pressure losses for a damper installed in a given HVAC system.

AMCA Test Figures

Figure 5.2 Illustrates a ducted damper exhausting air into an open area. This configuration has a lower pressure drop than Figure 5.5 because entrance losses are minimized by a straight duct run upstream of the damper.

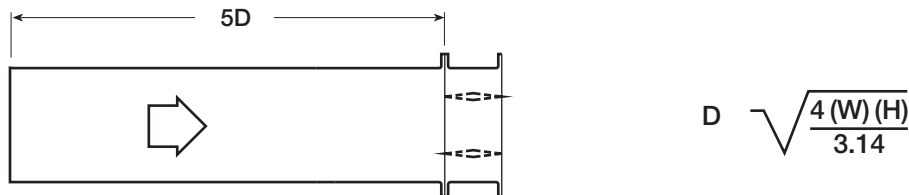

Figure 5.3 Illustrates a fully ducted damper. This configuration has the lowest pressure drop of the three test configurations because entrance and exit losses are minimized by straight duct runs upstream and downstream of the damper.

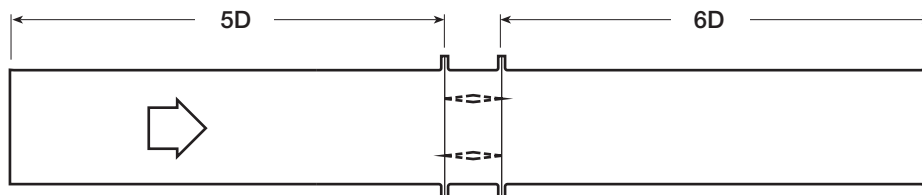
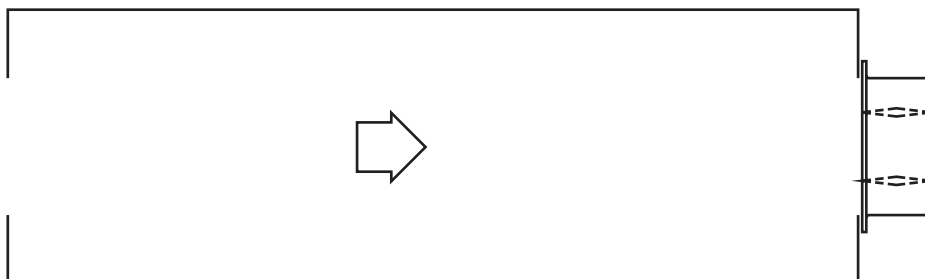

Figure 5.5 Illustrates a plenum mounted damper. This configuration has the highest pressure drop because of extremely high entrance and exit losses due to the sudden changes of area in the system.





Greenheck Fan Corporation certifies that the model VCD-43 shown herein is licensed to bear the AMCA Seal. The ratings shown are based on tests and procedures performed in accordance with AMCA Publication 511 and comply with the requirements of the AMCA Certified Ratings Programs. The AMCA Certified Ratings Seal applies to Air Leakage and Air Performance ratings.

AMCA 5.2

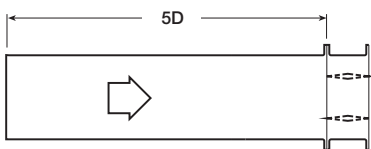

12 in. x 12 in. (305mm x 305mm)

Velocity (fpm)	Pressure Drop (in. wg)
500	0.01
1000	0.06
1500	0.13
2000	0.23
2500	0.35
3000	0.50
3500	0.68
4000	0.88

24 in. x 24 in. (610mm x 610mm)

Velocity (fpm)	Pressure Drop (in. wg)
500	0.01
1000	0.04
1500	0.10
2000	0.18
2500	0.28
3000	0.40
3500	0.54
4000	0.70

36 in. x 36 in. (914mm x 914mm)

Velocity (fpm)	Pressure Drop (in. wg)
500	0.01
1000	0.03
1500	0.06
2000	0.12
2500	0.18
3000	0.26
3500	0.35
4000	0.46

12 in. x 48 in. (305mm x 1219mm)

Velocity (fpm)	Pressure Drop (in. wg)
500	0.01
1000	0.06
1500	0.13
2000	0.23
2500	0.36
3000	0.51
3500	0.71
4000	0.93

48 in. x 12 in. (1219mm x 305mm)

Velocity (fpm)	Pressure Drop (in. wg)
500	0.01
1000	0.03
1500	0.06
2000	0.10
2500	0.16
3000	0.23
3500	0.30
4000	0.39

AMCA 5.3

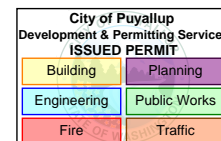
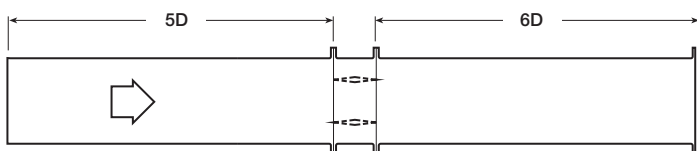

12 in. x 12 in. (305mm x 305mm)

Velocity (fpm)	Pressure Drop (in. wg)
500	0.01
1000	0.03
1500	0.07
2000	0.14
2500	0.21
3000	0.29
3500	0.39
4000	0.51

24 in. x 24 in. (610mm x 610mm)

Velocity (fpm)	Pressure Drop (in. wg)
500	0.01
1000	0.02
1500	0.04
2000	0.08
2500	0.13
3000	0.19
3500	0.26
4000	0.34

36 in. x 36 in. (914mm x 914mm)

Velocity (fpm)	Pressure Drop (in. wg)
500	0.01
1000	0.01
1500	0.02
2000	0.04
2500	0.06
3000	0.09
3500	0.13
4000	0.17

12 in. x 48 in. (305mm x 1219mm)

Velocity (fpm)	Pressure Drop (in. wg)
500	0.01
1000	0.03
1500	0.06
2000	0.11
2500	0.17
3000	0.25
3500	0.34
4000	0.45

48 in. x 12 in. (1219mm x 305mm)

Velocity (fpm)	Pressure Drop (in. wg)
500	0.01
1000	0.02
1500	0.04
2000	0.08
2500	0.12
3000	0.18
3500	0.24
4000	0.31

AMCA 5.5

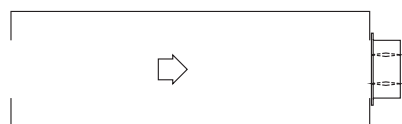

12 in. x 12 in. (305mm x 305mm)

Velocity (fpm)	Pressure Drop (in. wg)
500	0.04
1000	0.14
1500	0.31
2000	0.55
2500	0.86
3000	1.23
3500	1.67
4000	2.19

24 in. x 24 in. (610mm x 610mm)

Velocity (fpm)	Pressure Drop (in. wg)
500	0.03
1000	0.12
1500	0.27
2000	0.48
2500	0.75
3000	1.07
3500	1.47
4000	1.91

36 in. x 36 in. (914mm x 914mm)

Velocity (fpm)	Pressure Drop (in. wg)
500	0.03
1000	0.10
1500	0.22
2000	0.39
2500	0.61
3000	0.87
3500	1.19
4000	1.56

12 in. x 48 in. (305mm x 1219mm)

Velocity (fpm)	Pressure Drop (in. wg)
500	0.03
1000	0.11
1500	0.25
2000	0.46
2500	0.72
3000	1.05
3500	1.43
4000	1.87

48 in. x 12 in. (1219mm x 305mm)

Velocity (fpm)	Pressure Drop (in. wg)
500	0.03
1000	0.11
1500	0.26
2000	0.46
2500	0.72
3000	1.02
3500	1.40
4000	1.83

Leakage

Selection Criteria

Air leakage is based on operation between 32°F (0°C) and 120°F (49°C).

Tested for leakage in accordance with ANSI/AMCA Standard 500-D, Figure 5.5.

Tested for air performance in accordance with ANSI/AMCA Standard 500-D, Figures 5.2, 5.3 and 5.5.

Torque

Data are based on a torque of 5.0 in.lb./ft² (0.56 N·m) applied to close and seat the damper during the test.

VCD-43	Leakage Class*		
Maximum Damper Width	1 in. wg (0.25 kPa)	4 in. wg (1 kPa)	8 in. wg (2 kPa)
60 in. (1524mm)	1A	1	1
* applies to opposed blades only			



Greenheck Fan Corporation certifies that the model VCD-43 shown herein is licensed to bear the AMCA Seal. The ratings shown are based on tests and procedures performed in accordance with AMCA Publication 511 and comply with the requirements of the AMCA Certified Ratings Programs. The AMCA Certified Ratings Seal applies to Air Leakage and Air Performance ratings.

*Leakage Class Definitions

The *maximum* allowable leakage is defined as the following:

- Leakage Class 1A - 3 cfm/ft² at 1 in. wg (class 1A is only defined at 1 in. wg).
- Leakage Class 1
 - 4 cfm/ft² at 1 in. wg
 - 8 cfm/ft² at 4 in. wg
 - 11 cfm/ft² at 8 in. wg
 - 12.6 cfm/ft² at 10 in. wg

Velocity and Temperature Limitations

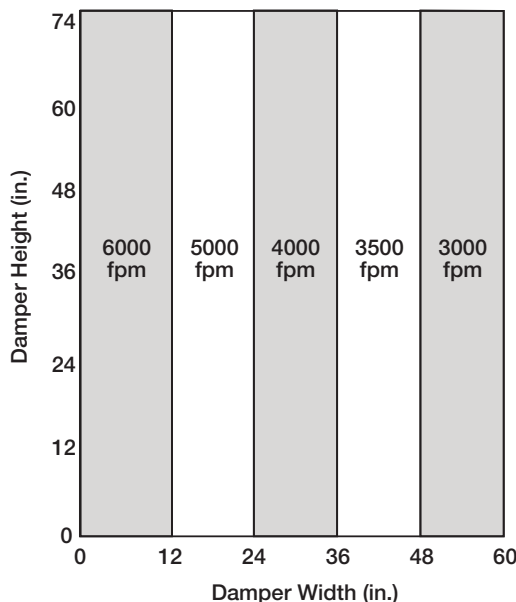

Temperature Limitations

Blade Seal	Temperature Range
TPE	-10°F to 180°F (-23°C to 82°C)
Silicone	-40°F to 250°F (-40°C to 121°C)

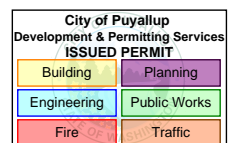

On dampers less than 18 in. (457mm) high, actuators may also require clearances above and/or below the damper frame. “B” and “T” dimensions are worst case clearance requirements for some dampers less than 18 in. (457mm) high. All damper sizes under 18 in. (457mm) high do not require these worst case clearances. If space availability above or below the damper is limited, each damper size should be individually evaluated.

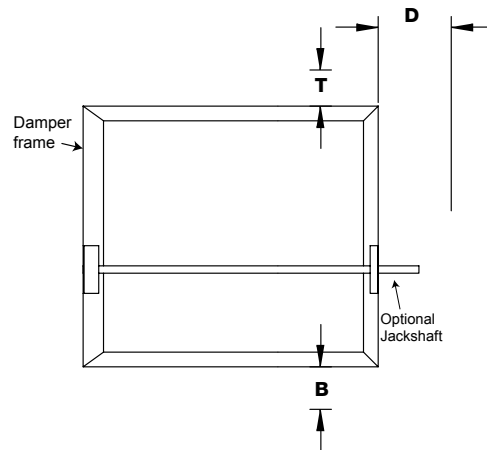

Actuator Type/Model	Height	T	B	D
	Inches (mm)	Inches (mm)		
AFBUP (-S) and FSNF Series, Belimo MSxx20 Series, Honeywell	≥6 to <10	0	12¾	6
	≥10 to <18	0	2	6
	≥18	0	0	10
FSLF, LF and TFB Series, Belimo	≥6 to <10	0	3½	6
	≥10	0	0	6
MSxx04 & MSxx09 Series, Honeywell	≥6 to <9	0	4¾	6
	≥9	0	0	6
MS75xx Series, Honeywell	≥6 to <10	0	12¾	6
	≥10 to <18	0	7	6
	≥18	0	0	6

This drawing depicts the worst case clearance requirements for an actuator with a jackshaft.

Internal mount only Actuator model	A	B	C
All except - EFB & EFCX Series	7¾ in. (197 mm)	3¾ in. (95 mm)	5⅝ in. (136.5 mm)
EFB & EFCX Series	8½ in. (216 mm)	6 in. (152 mm)	8½ in. (216 mm)

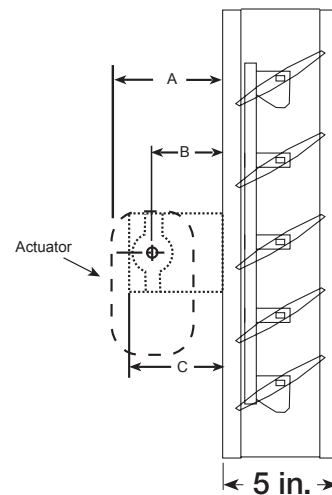

Mounting

- External - includes extension pin (standoff bracket optional)
- External kit - actuator and all mounting hardware
- Internal - blade lever

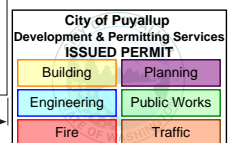

Multi-Section Assembly

Dampers larger than the maximum single section size, will be made up of a multiple of equal size sections. Multiple section dampers can be jackshafted together so that all sections operate together as shown below.

Refer to IOM document #463384 for structural support requirements on multi-section assemblies.

NOTE: Dampers larger than 60 in. x 74 in. (1524mm x 1880mm) are not intended to be structurally self supporting. Additional horizontal bracing is recommended to support the weight of the damper and vertical bracing should be installed as required to hold against system pressure.

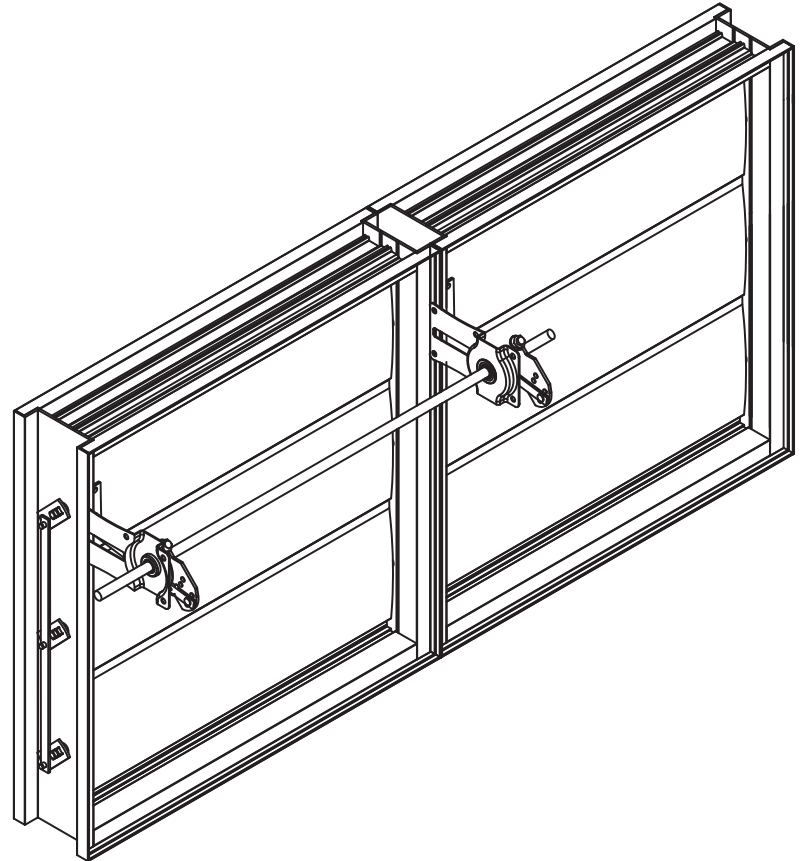

Specifications

Control dampers meeting the following specifications shall be furnished and installed where shown on plans and/or as described in schedules.

Dampers shall consist of: heavy gauge aluminum frame (0.125 in. [3.2mm] thick) with 5 in. (127mm) depth formed into a structural hat channel shape; airfoil shaped, extruded aluminum blades (0.063 in. [1.6mm] thick) with metal blade to blade overlap (seal to seal only contact is not acceptable); blades shall be symmetrical relative to their axle pivot point, presenting identical resistance to airflow and operation in either direction through the damper (blades that are non-symmetrical relative to their axle pivot point or utilize blade stops larger than 1/2 in. (13mm) are unacceptable); 1/2 in. (13mm) dia. plated steel axles turning in synthetic (acetal) sleeve bearings; TPE blade seals; flexible stainless steel jamb seals; and external (out of the airstream) blade-to-blade linkage.

Damper manufacturer's printed application and performance data including pressure, velocity and temperature limitations shall be submitted for approval showing damper suitable for pressures to 8 in. wg (2 kPa), velocities to 6000 fpm (30.5m/s) and temperatures to 250°F (121°C).

Damper manufacturer's printed performance data showing standard air leakage less than 6 cfm/ft² at 4 in. (.003 m³/s at 1 kPa) wg in either direction through the damper shall be submitted for approval.

Testing and ratings shall be developed in accordance with the latest edition of AMCA Standard 500-D.

Basis of design is VCD-43.



P.O. Box 410 • Schofield, WI 54476-0410 • 715.359.6171 • greenheck.com

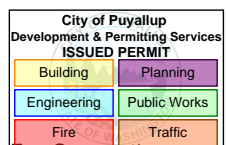

Copyright © 2020 Greenheck Fan Corporation

VCD-43 Rev. 22 December 2020

778 STAINLESS STEEL LATCH

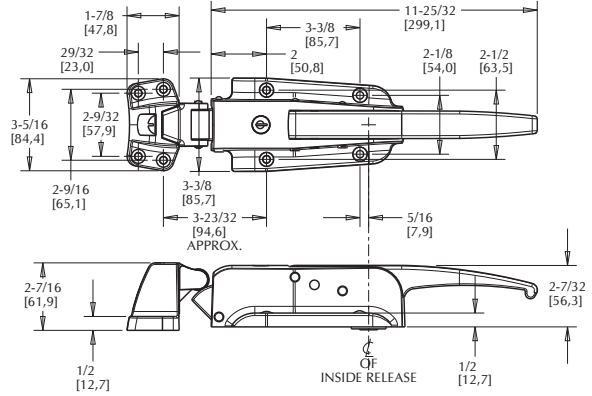

ITEM # 778



778 STAINLESS STEEL SAFEGUARD® LATCH

CORROSION RESISTANT SAFETY LATCH

- Radial tongue makes for effortless door closure when combined with Kason door closers
- The walk-in latch unsurpassed for reliability is now available for the most challenging applications
- No. 778 features unequalled strength and corrosion-resistance
- Tamper-resistant locking mechanism and mounting are built in.
- Adjustable roller strike assures precise adjustment
- Padlocking provision standard on all models
- Accepts Kason inside release lever to prevent accidental entrapment in locked walk-ins. Inside lever releases cylinder locked or padlocked door.

SPECIFICATIONS

MATERIAL:
Satin Finish, #316 stainless steel body and strike housing

MOUNTING:
Holes drilled and countersunk for 1/4" (6mm) screws

PACKAGING:
6 per carton

INSIDE RELEASE:
Accepts any "C" series inside release. See No. 481SC, shown below. Order separately

Model No.	Description	
10778CL6020*	Cylinder Latch Body, Light Spring	UL
10778L06020*	Padlocking Latch Body, Light Spring	UL
10778CH6020	Cylinder Latch Body, Heavy Spring	-
10778H06020	Padlocking Latch Body, Heavy Spring	-
10778006002	Strike, -1/8" to 3/4" (-3 - 19mm)	
10778006003	Strike, 3/4" to 1-5/8" (19 - 41mm)	
10778006004	Strike, -5/8" to 2-1/2" (41-64mm)	
10778006102	Strike, Stainless Steel Roller -1/8" to 3/4" (-3 - 19mm)	
10778006103	Strike, Stainless Steel Roller 3/4" to 1-5/8" (19 - 41mm)	
10778006104	Strike, Stainless Steel Roller 5/8" to 2-1/2" (41-64mm)	
90531CM000401	Replacement Cylinder Kit #401	
90531CM000402	Replacement Cylinder Kit #402	
90531CM000403	Replacement Cylinder Kit #403	
90531CM000404	Replacement Cylinder Kit #404	
90531CM000405	Replacement Cylinder Kit #405	

**Light Spring Models with roller strike

481SC STAINLESS STEEL INSIDE RELEASE

- Opens padlocked or cylinder locked No. 778 latch from inside of walk-in.
- Clearly visible Safety-Glow knob for added safety.

SPECIFICATIONS

MATERIAL:
Stainless steel rod and flange, glow in the dark plastic knob.

MOUNTING:
Holes drilled for No. 10 (5mm) screws

PACKAGING:
24 per carton



ITEM # 481SC



Model No.	Description
10481SC0400	Inside Release for 4" (102mm) Thick Door
10481SC0600	Inside Release for 6" (152mm) Thick Door

City of Puyallup Development & Permitting Services ISSUED PERMIT	
Building	Planning
Engineering	Public Works
Fire	Traffic

KASON STAINLESS STEEL SAFEGUARD® LATCH

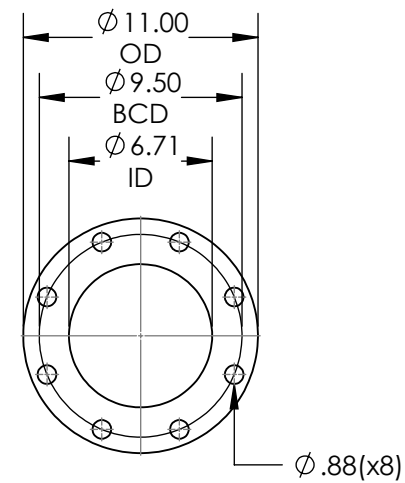
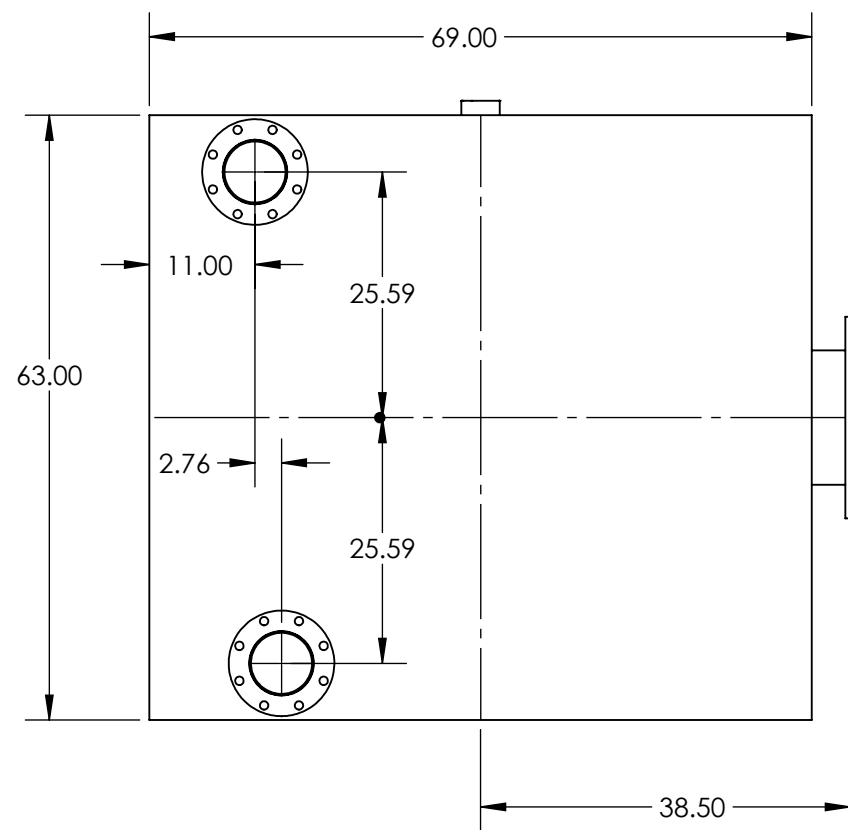
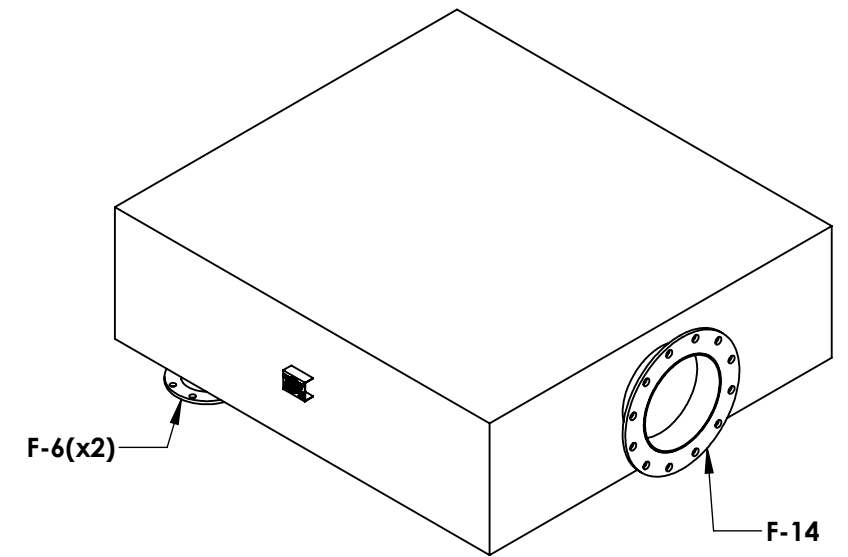
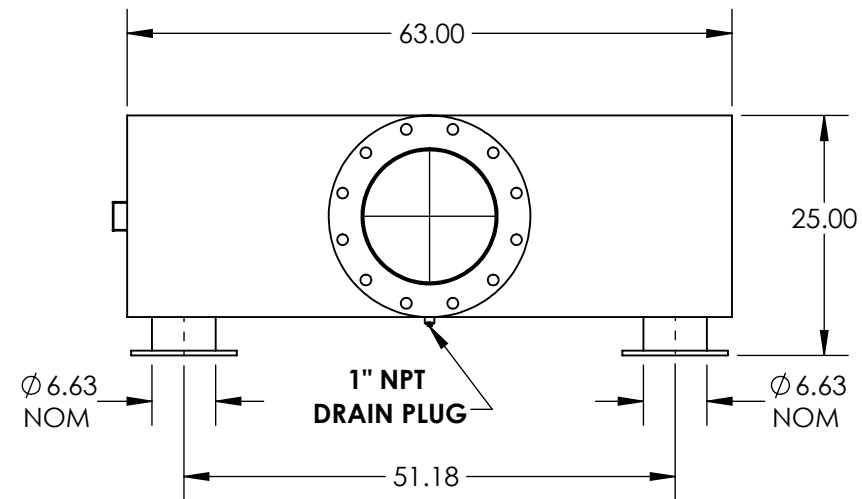
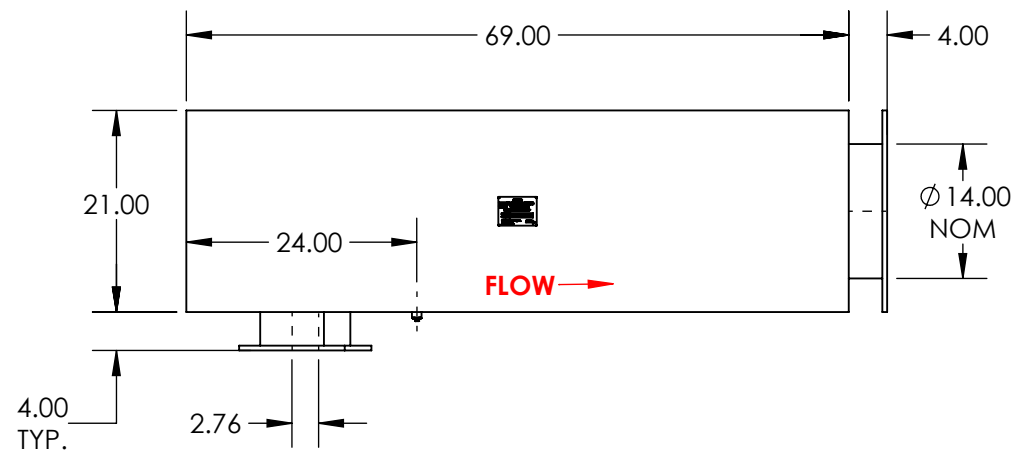

DETAIL F-6
6" ANSI 150# FLANGE(x2)
0.50" THK

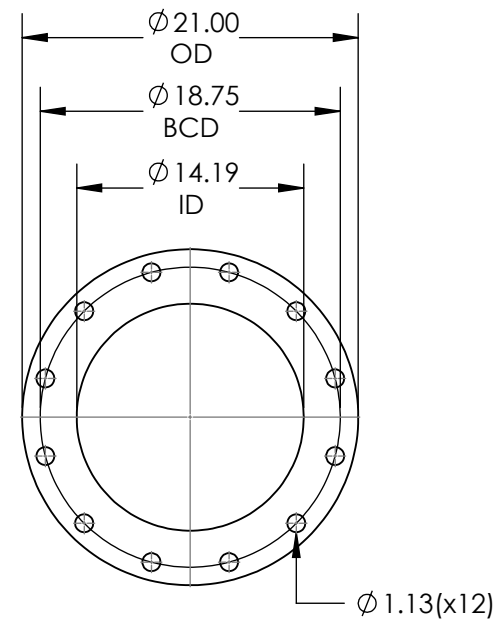

DETAIL F-14
14" ANSI 150# FLANGE
0.50" THK

SILENCER DETAIL

- SILENCER GRADE: CRITICAL GRADE
- ATTENUATION: 31-38 dBA
- SILENCER SHELL: STANDARD SHELL (NO INSULATION)
- SILENCER TUBES: STANDARD TUBES (NO INSULATION)

NOTES:

- ALL DIMENSIONS ARE IN INCHES
- DRAWING REQUIRES APPROVAL BEFORE PRODUCTION
- THIS IS NOT A FINAL PRODUCTION DRAWING, SOME DIMENSIONS MAY BE SUBJECT TO CHANGE

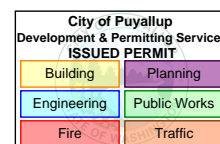

MATERIAL: CARBON STEEL CONSTRUCTION		PAINT: HIGH HEAT BLACK		APPROX. WEIGHT (LBS): 959
UNLESS OTHERWISE NOTED 1. REMOVE ALL BURRS AND SHARP EDGES 2. DIMENSIONS ARE IN INCHES TOLERANCES 0.XX ± 1/8" 0.XXX ± 1/16"		 E. I. WILLIAMS INDUSTRIES INC. Building Sound Solutions		CONTACT # 905-428-0950 INFO@EIWILLIAMS.COM WWW.EIWILLIAMS.COM
TITLE LOW PROFILE SILENCER		DRAWING # QUOTE# 24373		DATE 2024-08-01
MODEL # LCP-14C-D06		DRAWN BY AC		REV 00
				SHEET 1 OF 1

Model 354 Updraft Vent

SPECIFICATION SHEET

Application

Atmospheric updraft vents are installed on the top of storage tank vent pipes on underground and aboveground fuel storage tanks.

Features and Details

- Directs vapors outward and upward in accordance with NFPA 30
- Protects the vent line from debris and insects
- Water-resistant rain cap sheds water away from the vent line
- Slip-on design with set screws for easy installation
- Internal drain channels water penetration out through weep hole
- **354T** is compatible with DEF

Materials of Construction

354

- Body and cap... aluminum die cast
- Screen... 40 mesh stainless steel

354T

- Body and cap... PTFE coated black aluminum
- Screen... 40 mesh stainless steel

Certifications and Listings

- CARB 89-12 (1½" and 2" 354 models)



Item Number	Size (slip-on)	Weight (lbs)	Venting Capacity (SCFH) (@ 2.5 PSI)
354--0100 AV	1½"	0.75	27,650
354--0200 AV	2"	0.75	27,650
354--0300 AV	3"	1.50	59,000
354--0400 AV	4"	2.25	116,900
354T--0200 AV	2"	0.75	27,650
354T--0300 AV	3"	1.50	59,000

NOTE

Open vents will allow unrestricted evaporation of product.

WARNING: DO NOT FILL OR UNLOAD FUEL FROM A STORAGE TANK UNLESS IT IS CERTAIN THAT THE TANK VENTS WILL OPERATE PROPERLY.

Morrison tank vents are designed only for use on shop fabricated atmospheric tanks which have been built and tested in accordance with UL 142, NFPA 30 & 30A, and API 650 and in accordance with all applicable local, state and federal laws. In normal operation, dust and debris can accumulate in vent openings and block air passages. Certain atmospheric conditions such as a sudden drop in temperature, below freezing temperatures, and freezing rain can cause moisture to enter the vent and freeze which can restrict internal movement of vent mechanisms and block air passages. All storage tank vent air passages must be completely free of restriction and all vent mechanisms must have free movement in order to insure proper operation. Any restriction of airflow can cause excessive pressure or vacuum to build up in the storage tank, which can result in structural damage to the tank, fuel spillage, property damage, fire, injury, and death. Monthly inspection, and immediate inspection during freezing conditions, by someone familiar with the proper operation of storage tank vents, is required to insure venting devices are functioning properly before filling or unloading a tank. Normal vents such as pressure vacuum and updraft vents for aboveground storage tanks should be sized according to NFPA 30 (2008) 21.4.3

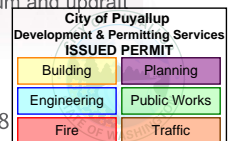

366 Female Thread High Flow Emergency Vent for Aboveground Storage Tanks



366 HF

Features:

All Aluminum Construction is lightweight for easy handling and installation. Also, no rust issues from scratches or weathering. Buna-N O Ring provides a vapor resistant seal. Spring Actuated Vent assures accurate opening pressure. Pressure relief set at <0.5 PSI. Clay & Bailey vents can be used in a variety of Aboveground Storage Tank Equipment installations where reliable fuel handling petroleum equipment is required.

Airflow

<u>Part #</u>	<u>Size</u>	<u>Weight /lbs.</u>	<u>Size</u>	<u>W/Screen</u>	<u>W/O Screen</u>
0366-03-30HF	3"	3	3"	66,400 SCFH	71,750 SCFH
0366-03-40HF	4"	4	4"	114,800 SCFH	118,750 SCFH
0366-03-50HF	5"	5	5"	184,500 SCFH	200,250 SCFH
0366-03-60HF	6"	6	6"	237,000 SCFH	251,700 SCFH
0366-03-80HF	8"	7	8"	500,552 SCFH	531,289 SCFH



Clay & Bailey emergency vents comply with various codes – Petroleum Equipment Institute PEI RP200; Underwriters Laboratories Inc. UL-142, UL-2085, UL-2244, UL-2583; Underwriters Laboratories of Canada ULC-S601; National Fire Protection Agency NFPA 30, NFPA 30A; American Petroleum Institute API 2000.

Patent # 8171955

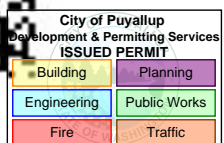

10/2018



KRUEGER SENTRY GAUGE®

The Therma Gauge—Type H



Part Number—
H-(size opening)-(tank depth)+(ext)-(list options)
Sample—H-2-48+12

What it is:

Top mounted liquid level gauge that can measure from 6 inches to 144 inches in depth. Bushing size can be 2" or 1.5". Gauges are custom made in house to fit your tank. Can also accommodate for double walls and pipe risers. The Type H Gauge has a 2 piece bushing construction that allows you to aim your swing arm away from walls, corners, and other obstructions.

Additional Options - Not included:

Audible Alarm Accessory: This add on feature can turn your mechanical gauge into an audible Hi or Lo level alarm.

LED At-A-Glance Accessory: Another add on feature. This can give your mechanical gauge remote reading capability.

Gauge Guard: A cover that protects the exposed plastic components on top of the gauge.

Replacement Parts -

H-Kit - Replaces all of the gauge components from the red lock nut and up. Includes: Red HDPE Plastic Nut, Duro Nitrile Gasket, Plastic Cellulose acetate inner and outer calibration.

HG-Kit-ALN - Replaces all of the gauge components from the red lock nut and up with upgraded parts. Includes: Aluminum Lock Nut, Duro Nitrile Gasket, Plastic Cellulose acetate outer calibration, Glass inner calibration.

Instructions for Operation:

This gauge is a simple volume reading tool. The top of the red indicator is an indication of your approximate fuel level in your tank. Once installed, you simply view the calibration to monitor your tank level. Indicator is calibrated in eighths of a tank on one side, and quarters of a tank on the other.

Krueger Sentry Gauge
1873 Siesta Lane
Green Bay, WI 54313

www.ksentry.com



Contact us for all your Permitting Services
Ph: 920-437-8800
Fax: 920-437-8807
Email: info@ksentry.com

City of Puyallup	ISSUED PERMIT
Building	Planning
Engineering	Public Works
Fire	Traffic

Madison Co.
 27 Business Park Dr.
 Branford, CT 06405 US
 Phone: 203-488-4477
 Fax: 203-481-5036
 Toll-free: 800-466-5383
 Email: info@madisonco.com
 Website: http://www.madisonco.com



Plastic Miniature Liquid Level Float Switches

Madison Company offers a complete line of standard Single Point Plastic Miniature Liquid Level Float Switches. Madison Company can also custom design specific liquid level switches for OEM applications that require unique materials, configurations and system interfaces.

High reliability of the magnetic reed switch technology assures repeatability at an economical price.

Features

- Single-point
- Magnetic float switch technology
- High reliability
- Wide selection of available materials
- Direct interface to controllers available

Each style switch is equipped with a means to indicate Normally Open (NO) or Normally Closed (NC) operation:

Vertical Switches: NO/NC operation is indicated by the position of a witness mark. NO is indicated by circle up; NC is indicated by circle down.

An ohmmeter or continuity meter may be used to verify the switch setting and operation. Simply connect the meter to the leads with the float hanging down away from the fitting and measure the switch. If the meter reads a short, then the switch is normally closed and will open on rise.

All switches are shipped in the NC position, unless otherwise specified. To change the contact operation, simply remove the retaining ring and float and reverse the float on the stem. The only exception to this is the subminiature switch (M3326/M3326-NO), for which operation must be specified when ordered, since the float is not reversible on this switch.

Results 1 - 8 of 8

Item #	Type	Stem Material	Float Material	Max. Temperature	Fittings	Nominal Current Rating(s)	Float SG	Max. Pressure
M8000-6PKG	Miniature Switch	Polypropylene	Polypropylene	105 °C 221 °F	1/8" NPT	30 VA SPST Switch	0.80	100 psig
M4008	Miniature Switch	Polypropylene	Buna-N	105 °C	1/8" NPT	30 VA SPST Switch	0.45	150 psig
M7000-6PKG	Miniature Switch	PBT	Buna-N	105 °C	1/8" NPT	30 VA SPST Switch	0.45	150 psig
M9000	Miniature Switch	Kynar	Buna-N	105 °C	1/8" NPT	30 VA SPST Switch	0.85	15 psig
MS8000	Miniature Switch with Slosh Shield	Polypropylene	Polypropylene	105 °C	1/8" NPT	30 VA SPST Switch	0.80	100 psig
MS4008	Miniature Switch with Slosh Shield	Polypropylene	Buna-N	105 °C	1/8" NPT	30 VA SPST Switch	0.45	150 psig
MS7000	Miniature Switch with Slosh Shield	PBT	Buna-N	105 °C	1/8" NPT	30 VA SPST Switch	0.45	150 psig
MS9000	Miniature Switch with Slosh Shield	Kynar	Buna-N	105 °C	1/8" NPT	30 VA SPST Switch	0.85	15 psig

Results 1 - 8 of 8

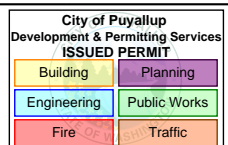

Narrow Body Secondary Containment Leak Sensor

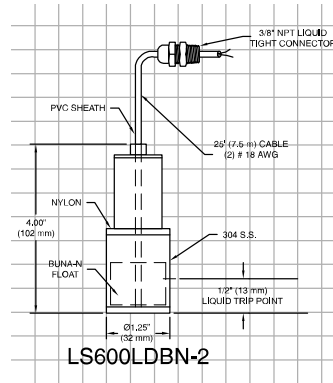

Product Description

The LS600LDBN-2 float-actuated leak sensor provides secondary containment leak detection for above ground and underground storage tank applications where the LS600LDBN-1 cannot be used due to the smaller opening. The sensor assembly may be suspended at the desired point of actuation via the sensor cable and compression fitting, or allowed to rest at the bottom of the containment area being monitored. The compact size and favorable displacement properties of the LS600LDBN-2 make it ideal for monitoring shallow liquid levels. The LS600LDBN-2 optionally supports Pneumercator's FAULT-DETECT supervised wiring technology, which automatically detects field wiring faults when connected with a TMS series or LC2000 controller.

Applications

- Containment, Manway and Piping Sumps
- Dispenser Pan
- Turbine Enclosure
- Double-Wall Steel Tank
- Narrow Body Version For 1.25" NPT Opening

Specifications

- Technology: Magnetic Float, Hermetically Sealed Reed Switch
- Wetted Materials: Float: Buna-N
Housing: 304SS and Nylon
Stem: Brass
- Cable: 22AWG, 2-Conductor, 25' (7.5 m) Length, PVC-jacketed
- Operating Temperature: -20 °F to 175 °F (-30 °C to 80 °C)
- Pass-thru Opening Size: Minimum 1.25" NPT (38 mm)
- Location Approval*: UL Class I, Div 1, Groups C and D; cUL Class I, Zone 0, Group IIB

Installation

Sensor may be suspended by its cable or placed on the containment or sump floor.

Certifications/Approvals

- UL/cUL Approved*, File #E139464
- Third-Party EPA Listed*

Ordering

- LS600LDBN-2(-F,-FL) Buna-N Float, Brass Shaft, and PVC wiring

(-F) denotes Fault-Detect Option for LC2000/TMS2000/3000/4000

(-FL) denotes Fault Detect Option for TMS1000/2000W/4000W/WiDAM

*When used in conjunction with the LC2000/TMS series controllers or TMS2000W/4000W series WiDAM Wireless Data Acquisition Module



Pneumercator Company, Inc.
1785 Expressway Drive North
Hauppauge, New York 11788

Note: Specifications subject to change without notice

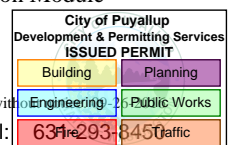

Tel: 631-293-8450
Fax: 631-293-8533

<http://www.pneumercator.com>

REV.	DESCRIPTION	BY	EO
A	RELEASED TO PRODUCTION	JCY	12-32

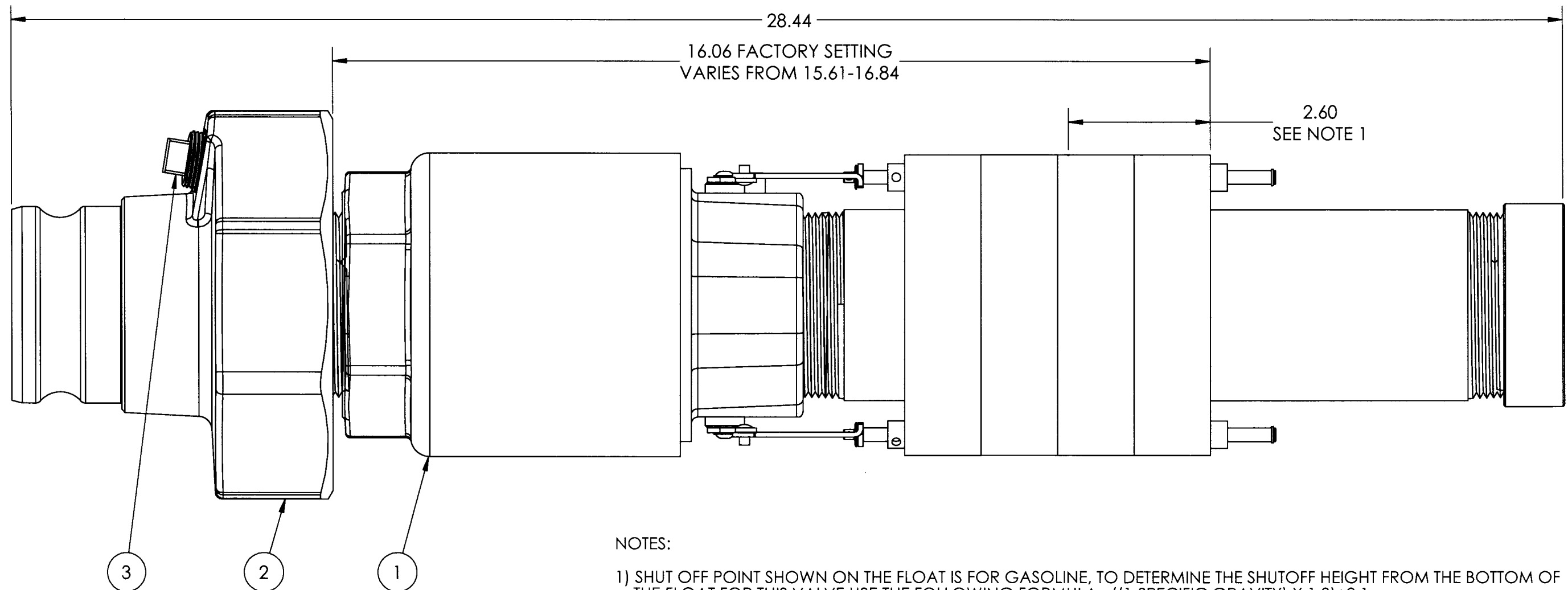

NOTES:

- 1) SHUT OFF POINT SHOWN ON THE FLOAT IS FOR GASOLINE, TO DETERMINE THE SHUTOFF HEIGHT FROM THE BOTTOM OF THE FLOAT FOR THIS VALVE USE THE FOLLOWING FORMULA: $((1-\text{SPECIFIC GRAVITY}) \times 1.8) + 2.1$
- 2) WETTED MATERIALS:
ANODIZED ALUMINUM/STAINLESS STEEL ALLOYS 303 AND 18-8/ E-COATED STEEL PIPE/ NITROPHYL-M/ DELRIN/ PTFE
- 3) THIS OVERFILL PREVENTION DEVICE IS COMPATIBLE WITH FLUIDS THAT HAVE A DENSITY GREATER THAN .647 GRAMS PER ML / 5.40 LBS PER GALLON AND A MAX VISCOSITY OF 300 CENTISTOKES.
- 4) THIS OVERFILL VALVE REQUIRES A MINIMUM INLET PRESSURE OF 5 PSI. THE MAX INLET PRESSURE OF THIS VALVE IS 100 PSI.
- 5) WORKING TEMPERATURE: -40 °F TO 160 °F.
- 6) FLUID COMPATIBILITY:
GASOLINE, GASOLINE ETHANOL BLEND, E-100, DIESEL FUEL, BIODIESEL, AVGAS, AND FUEL OIL.
OTHER FLUIDS MAY ALSO BE COMPATIBLE WITH FURTHER REVIEW.

ITEM NO.	DESCRIPTION	PART NUMBER	QTY
1	2" OVERFILL PREVENTION VALVE	9095AA9300 AV	1
2	ADAPTOR, MACHINED	9095A-0301 MAAH	1
3	PIPE PLUG	9095A-3202 2P	1

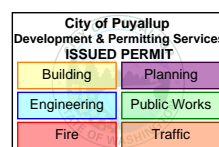

STANDARD TOLERANCES UNLESS OTHERWISE SPECIFIED
1 PL DECIMAL ±.100
2 PL DECIMAL ±.015
3 PL DECIMAL ±.005
ANGULAR ± 2.0°
SURFACE FINISH 125μinch RMS MAX
TOOL NOSE RADIUS .035 MAX
BREAK AND DEBURR ALL SHARP EDGES
DIMENSIONS ARE IN INCHES

TITLE: 3" OVERFILL PREVENTION VALVE	
THIRD ANGLE	MATERIAL: SEE NOTE 2
SCALE 1:2	Drawn: JCY Date: 11/16/2011 Checked: <i>[Signature]</i> Date: 7-31-12
	DO NOT SCALE DRAWING

Morrison Bros. Co.
Dubuque, IA
PART I.D. NO. 9095AA0300 AV
DWG. NO. B-7706-0

SOLID WORKS
 THE INFORMATION CONTAINED IN THIS DRAWING IS THE SOLE PROPERTY OF MORRISON BROS. CO. TO BE USED ONLY FOR PURPOSE EXPLICITLY DIRECTED BY MORRISON BROS. CO. ANY REPRODUCTION IN PART OR AS A WHOLE WITHOUT THE WRITTEN PERMISSION OF MORRISON BROS. CO. IS PROHIBITED.
 CONFIDENTIAL

Commercial Automatic Fuel Polishing 600 GPH

Automatic Fuel Polishing (AFP) removes water, bacterial growth and other particulate from diesel that are detrimental to fuel systems and thereby resolving many issues related to degraded fuel.

Basic Features

- Primary filtration - Separ Filter with vacuum gauge
- Secondary filtration - 2 micron
- Available in 120V and 220V
- Aluminum cover and base with spill containment
- Mountable base
- Water level alarm and shutoff
- Vacuum alarm and shutoff
- Spill alarm and shutoff

Optional Features

- Enclosure
- Enclosure with stand



Wall Mount



Enclosure



Enclosure with Stand

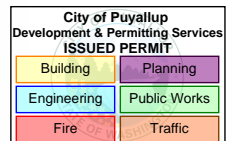

Technical Specifications

Flow Rate	600 GPH / 2271 LPH	
Inlet / Outlet	1" Male JIC	
Voltage	120V or 220V	
Amp. Draw	3.4A, 110V / 60Hz 3.2A, 220V / 50Hz	
Circuit Breaker	10A, 110V / 60Hz 10A, 220V / 50Hz	
Lift	13 ft / 4 m with foot valve above liquid level	
Pump Type	Vane Pump	
Primary Filtration	Standard 30 micron	
Secondary Filtration	2 micron	
Wall Mount Dimensions	A	28.4" / 721 mm
	B	28.2" / 716 mm
	C	10.9" / 276 mm
Enclosure Dimensions	A	34.5" / 876 mm
	B	30" / 762 mm
	C	12" / 305 mm
Enclosure with Stand Dimensions	A	34.5" / 876 mm
	B	59.75" / 1518 mm
	C	12" / 305 mm

Replacement Elements

04010	10 micron
04030	30 micron
04060S	60 micron, stainless steel
04-3382	2 micron spin on

NO.	1	DATE	17/04/03	BY	JW	REVISION	ADDED ENCL BOTTOM DRAWING	DES:	JWEN
								DATE:	15/11/09
								SCALE:	NTS

TITLE: 3PH DISTRIBUTION TRANSFORMER
NAMEPLATE INFORMATION

SHEET 1 OF 3
EDBSG3A0030KB



HPS Sentinel® G

Hammond Energy Efficient Distribution Transformer
Power Solutions Transformateur de Distribution à Bon Rendement Énergétique

Guelph, ONT Baraboo, WI
Compton, CA Monterrey, MX

Part No. SG3A0030KB



LR 3902



DRY TYPE TRANSFORMER
7705
E112313

LISTED ALSO VERIFIED IN ACCORDANCE TO ENERGY STANDARD C802.2-12

Cust. Ref. Ref. du Client		Serial No. No. de Serie					SPACINGS BETWEEN ANY VENTILATED ENCLOSURE PANEL AND ANY ADJACENT WALL SHALL BE A MINIMUM OF 3 INCHES
Phase	3	HV/HT	480V	36.1A	VOLTS	CURRENT COURANT	
Type	K	BIL	10 kV		504	34.4	
Cooling Refroidissement	ANN	Term Bornes	H1 H2 H3		492	35.2	
kVA	30	LV/BT	208Y/120V	83.3A	480	36.1	
Temp. Rise Echauffement	150 °C	BIL	10 kV		468	37.0	
Temp Class Classe Temp	220 °C	Term Bornes	X0 X1 X2 X3		456	38.0	
Winding Enroulement	AL	Energy Regulations Reglements de Energetique	DOE 10 CFR PART 431:2016		444	39.0	
Frequency Frequence Hz	60		CEE ACT SOR/2018-201		432	40.1	
Impedance % @ 170 °C	4						
Encl Type Type De Coffrage	3R						
Wt LBS Poids en lbs	290						

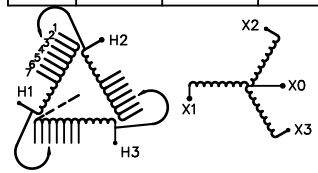

SEISMIC QUALIFICATIONS, OSP-0136-10
IBC 2015/ASCE 7-10
SDS<=2.0g Z/h=1 Ip=1.5

000106hh

City of Puyallup
Development & Permitting Services
ISSUED PERMIT

Building	Planning
Engineering	Public Works
Fire	Traffic

FRONT VIEW

SIDE VIEW

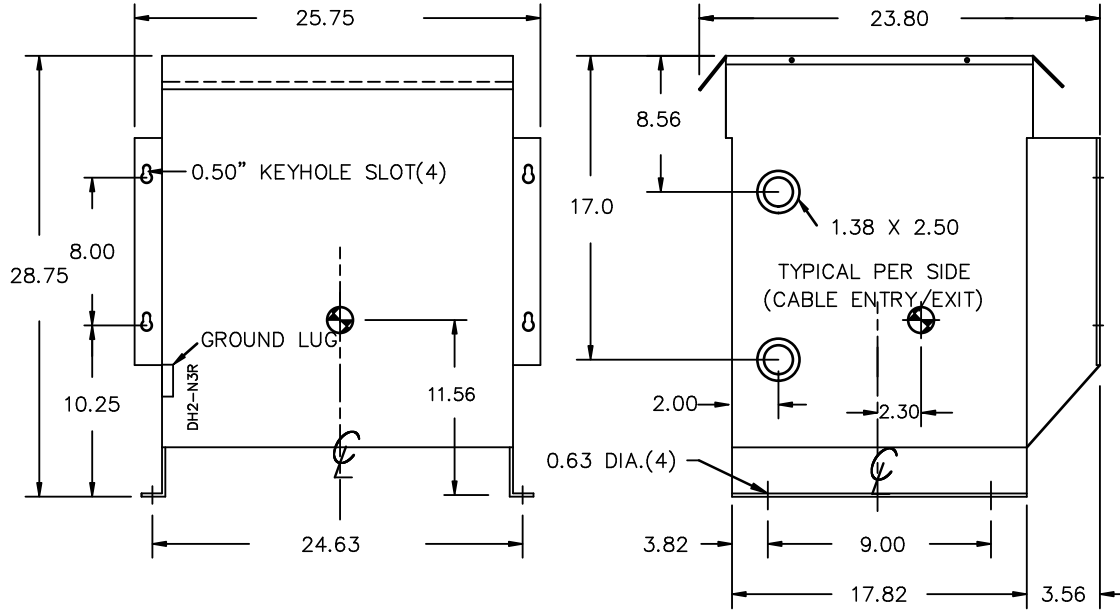

All Dimensions in inches

ENCLOSURE COLOR : ANSI 61 GREY – OUTDOOR

HV TERMINAL DETAIL

LV TERMINAL DETAIL

MECHANICAL TYPE LUGS INCLUDED
SUITABLE FOR #14-2 CU/AL
CONDUCTORS
1 CONDUCTOR PER PHASE

MECHANICAL TYPE LUGS INCLUDED
SUITABLE FOR #2/0-14 CU/AL
CONDUCTORS
1 CONDUCTOR PER PHASE

CUSTOMER NOTES:

- HV TERMINATED AT TOP FRONT
- LV TERMINATED AT BOTTOM FRONT

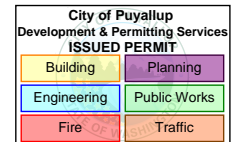

TITLE: 3PH DISTRIBUTION TRANSFORMER

1	17/04/03	JW	ADDED ENCL BOTTOM DRAWING	DES: JWEN
				DATE: 15/11/09
NO.	DATE	BY	REVISION	SCALE: NTS

SHEET 2 OF 3

EDBSC3A0030KB

1.3 cshoh 2019/11/05 13:26

ENCLOSURE BOTTOM VIEW

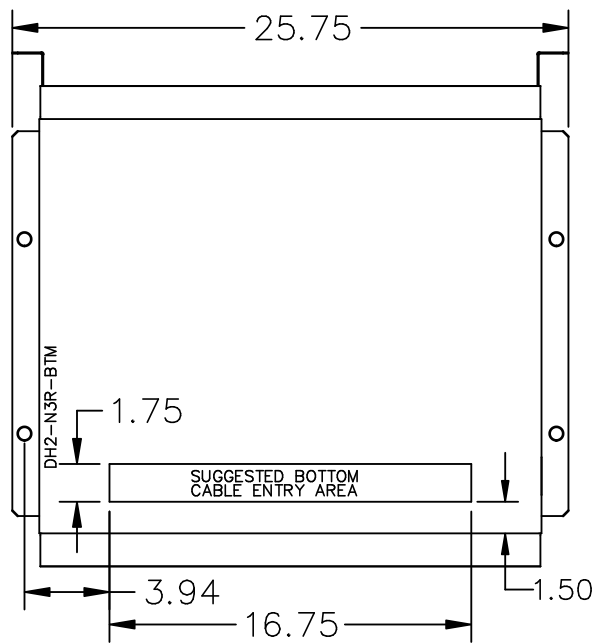

NOTE:
 WHEN BOTTOM CABLE ENTRY IS OPTED, THE SPACE USED FOR CONDUITS IN THE FRONT OF THE TRANSFORMER SHOULD NOT OBSTRUCT MORE THAN 50% OF THE FRONT AIR INTAKE AREA DEFINED BETWEEN THE BOTTOM PLATE AND THE SUPPORTING LEGS.
 SEE MANUAL FOR ADDITIONAL INFORMATION



TITLE: 3PH DISTRIBUTION TRANSFORMER
 ENCLOSURE BOTTOM VIEW

1	17/04/03	JW	ADDED ENCL BOTTOM DRAWING	DES: JWEN
NO.	DATE	BY	REVISION	SCALE: NTS

SHEET 1 OF 1
 City of Evansville
 Development & Permitting Services
 ISSUED PERMIT

Building	Planning
Engineering	Public Works
Fire	Traffic

13:26



Product availability: Stock - Normally stocked in distribution facility



Main

Product or component-type	Single Throw Safety Switch
Line Rated Current	60 A
Product certifications	UL listed
NEMA degree of protection	NEMA 1 steel
Device composition	Neutral (factory installed)
Disconnecter device-type	Fusible disconnect
Short-circuit current	10 kA H or K 200 kA R, J or L
Device mounting	Surface
Number of poles	3
Electrical connection	Lugs
Series name	Heavy duty
System Voltage	600 V AC/DC
AWG gauge	AWG 14...AWG 3 (copper or aluminium)

Ordering and shipping details

Category	00008 - H&HU SW,2&3P,N1,30-200A
Discount Schedule	DE1
GTIN	00785901482215
Nbr. of units in pkg.	1
Package weight(Lbs)	15.470000000000001
Returnability	Y
Country of origin	US

Offer Sustainability

Sustainable offer status	Green Premium product
RoHS (date code: YYWW)	Compliant - since 1313 - Schneider Electric declaration of conformity Schneider-Electric declaration of conformity
REACH	Reference not containing SVHC above the threshold
Product environmental profile	Available
Product end of life instructions	Need no specific recycling operations
California proposition 65	WARNING: This product can expose you to chemicals including:
----- Substance 1	Lead and lead compounds, which is known to the State of California to cause cancer and birth defects or other reproductive harm.
----- More information	For more information go to www.p65warnings.ca.gov

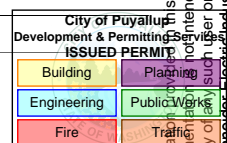

Contractual warranty

Warranty period	18 months
-----------------	-----------

Product Life Status :	Commercialised
-----------------------	----------------

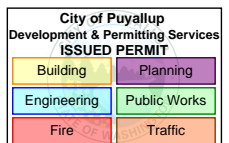

Product data sheet

Characteristics

NQ418L1C

Panelboard interior, NQ, main lugs, 100A Frame, Cu bus, 18 pole spaces, 3 phase, 4 wire, 240 VAC, 48 VDC



by Schneider Electric



Product availability: Stock - Normally stocked in distribution facility

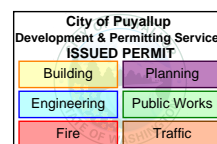

Main

Load center type	Main lugs
Circuit breaker type	QOB QOB-VH QHB
Material	Copper

Complementary

Number of spaces	18
Enclosure nominal height	26 In (660.40 mm)
Enclosure nominal width	20 In (508.00 mm)
Enclosure nominal depth	5.75 In (146.05 mm) NEMA 1 6.5 In (165.10 mm) NEMA 3R/5/12
Line Rated Current	100 A
[Iu] rated interrupted current	10 KA 22 KA 65 KA
Wiring configuration	4-wire
Phase	3 phase
[Ue] rated operational voltage	240 V AC 48 V DC
Connections - terminals	Lug line AWG 6...AWG 2/0 aluminium Lug neutral AWG 6...AWG 2/0 aluminium
Net Weight	12.50 Lb(US) (5.67 kg)
Tightening torque	40.01...50.01 Lbf.In (4.52...5.65 N.m) 0.02...0.10 in ² (13.30...67.43 mm ²) AWG 6...AWG 2/0) 100.01 Lbf.In (11.3 N.m) 0.02...0.10 in ² (13.30...67.43 mm ²) AWG 6...AWG 2/0) 274.99 Lbf.In (31.07 N.m) 0.02...0.27 in ² (13.30...177.3 mm ²) AWG 6...350 kcmil) 274.99 Lbf.In (31.07 N.m) 0.02...0.20 in ² (13.30...126.7 mm ²) AWG 6...250 kcmil) 274.99 Lbf.In (31.07 N.m) 0.17...0.24 in ² (107.2...152 mm ²) AWG 4...300 kcmil)

The information provided in this documentation contains general descriptions and/or technical characteristics of the performance of the products contained herein. This documentation is not intended as a substitute for and is not to be used for determining suitability or reliability of these products for specific user applications. It is the duty of any such user or integrator to perform the appropriate and complete risk analysis, evaluation and testing of the products with respect to the relevant specific application or use thereof. Neither Schneider Electric Industries SAS nor any of its affiliates or subsidiaries shall be responsible or liable for misuse of the information contained herein. *Prices are indicative

Width	10.44 In (265.18 mm)
Height	27 In (685.80 mm)

Environment

Standards	UL CSA
-----------	-----------

Ordering and shipping details

Category	09151 - NQ RTA PANELBOARDS
Discount Schedule	PE1A
GTIN	00785901502173
Nbr. of units in pkg.	1
Package weight(Lbs)	14.75 Lb(US) (6.69 kg)
Returnability	Yes
Country of origin	MX

Packing Units

Unit Type of Package 1	PCE
Package 1 Height	6.50 In (16.51 cm)
Package 1 width	14.00 In (35.56 cm)
Package 1 Length	26.00 In (66.04 cm)
Unit Type of Package 2	PAL
Number of Units in Package 2	24
Package 2 Weight	366.00 Lb(US) (166.015 kg)
Package 2 Height	42.50 In (107.95 cm)
Package 2 width	40.00 In (101.6 cm)
Package 2 Length	48.00 In (121.92 cm)

Offer Sustainability

Sustainable offer status	Green Premium product
California proposition 65	WARNING: This product can expose you to chemicals including: Nickel compounds, which is known to the State of California to cause cancer, and Bisphenol A (B-PA), which is known to the State of California to cause birth defects or other reproductive harm. For more information go to www.P65Warnings.ca.gov
REACH Regulation	REACH Declaration
REACH free of SVHC	Yes
EU RoHS Directive	Compliant EU RoHS Declaration
Mercury free	Yes
RoHS exemption information	Yes
China RoHS Regulation	China RoHS Declaration
Environmental Disclosure	Product Environmental Profile

Contractual warranty

Warranty	18 months
----------	-----------

Product Life Status : **Commercialised**

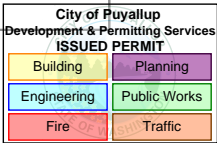

Product data sheet

Characteristics

NQMB2Q

NQ Panelboard Acc. Main Breaker Kit 225A Frame, Q Frame

Product availability : Stock - Normally stocked in distribution facility



Main

Product	Installation kit
Accessory / separate part category	Installation accessory
Total number of wires	3
Provided equipment	Connector 6
Circuit breaker type	QB

Complementary

Number of spaces	30
	42
	84
	72
	54
Device Application	QB/QD/QJ/QL circuit breaker 225 A
Tightening torque	274.37 lbf.in (31 N.m)

Environment

Product certifications	CSA
------------------------	-----

Ordering and shipping details

Category	09151 - NQ RTA PANELBOARDS
Discount Schedule	PE1A
GTIN	00785901666103
Nbr. of units in pkg.	1
Package weight(Lbs)	9.2 lb(US) (4.17 kg)
Returnability	Yes

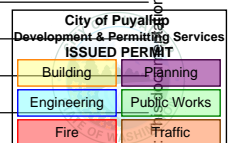

* Price is "List Price" and may be subject to a trade discount – check with your local distributor or retailer for actual price.

This information is not intended as a substitute for and is not to be used for determining suitability or reliability of these products for specific user applications.

Country of origin	US
-------------------	----

Packing Units

Unit Type of Package 1	PCE
Package 1 Height	3.60 in (9.144 cm)
Package 1 width	16.60 in (42.164 cm)
Package 1 Length	20.70 in (52.578 cm)
Unit Type of Package 2	PAL
Number of Units in Package 2	60
Package 2 Weight	591.00 lb(US) (268.073 kg)
Package 2 Height	25.00 in (63.5 cm)
Package 2 width	42.00 in (106.68 cm)
Package 2 Length	48.00 in (121.92 cm)

Offer Sustainability

Sustainable offer status	Green Premium product
REACH Regulation	REACH Declaration
REACH free of SVHC	Yes
EU RoHS Directive	Compliant EU RoHS Declaration
Mercury free	Yes
RoHS exemption information	Yes
China RoHS Regulation	China RoHS declaration Product out of China RoHS scope. Substance declaration for your information.
Environmental Disclosure	Product Environmental Profile

Contractual warranty

Warranty	18 months
----------	-----------

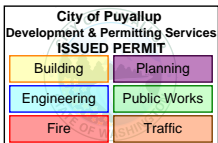

Main Line Circuit Breaker

PowerPact H-, J-, and L-Frame Circuit Breakers General Information

Table 11: Circuit Breakers

Circuit Breaker		150 A H-Frame					250 A J-Frame					400 A L-Frame					600 A L-Frame					1200 A L-Frame			
Circuit Breaker Type		HD	HG	HJ	HL	HR	JD	JG	JJ	JL	JR	LD	LG	LJ	LL	LR	LD	LG	LJ	LL	LR	LG	LL		
Number of poles ¹		2, 3			3		2, 3			3		3, 4			3, 4			3, 4		4					
Amperage Range (A)		15-150					70-250					70-400					200-600					700-1200			
UL 489 Circuit Breaker Ratings																									
Breaking Capacity (AIR)	240 Vac	25	65	100	125	200	25	65	100	125	200	25	65	100	125	200	25	65	100	125	200	—	—		
	480 Vac	18	35	65	100	200	18	35	65	100	200	18	35	65	100	200	18	35	65	100	200	—	—		
	600 Vac	14	18	25	50	100	14	18	25	50	100	14	18	25	50	100	14	18	25	50	100	—	—		
	250 Vdc ²	20	20	20	20	—	20	20	20	20	—	—	—	—	—	—	—	—	—	—	—	—	—		
UL/CSA/NOM (kA rms)	500 Vdc ^{2, 3}	—	20	—	50	—	—	20	—	—	50	—	—	20	—	—	50	—	—	20	—	20	—	20	50
IEC 947-2 Circuit Breaker Ratings																									
Ultimate breaking capacity (Icu) (kA rms)	220/240 Vac	25	65	100	125	150	25	65	100	125	150	25	65	100	125	150	25	65	100	125	150	—	—		
	380/415 Vac	18	35	65	100	125	18	35	65	100	125	18	35	65	100	125	18	35	65	100	125	—	—		
	440/480 Vac	18	35	65	100	125	18	35	65	100	125	18	35	65	100	125	18	35	65	100	125	—	—		
	500/525 Vac	14	18	25	50	75	14	18	25	50	75	14	18	25	50	75	14	18	25	50	75 ⁴	—	—		
	690 Vac	—	—	—	—	20	—	—	—	—	20	—	—	—	—	20	—	—	—	—	20	—	—		
	250 Vdc ²	—	—	—	—	—	20	20	20	20	—	—	—	—	—	—	—	—	—	—	—	—	—		
500 Vdc ^{2, 3}	—	—	—	—	—	20	20	20	20	—	—	—	—	—	—	—	—	—	—	—	—	—			
Service breaking capacity (Ics)	% Icu	100%					100%					100%					100%		—	—					
Insulation Voltage	V _i	750 Vac					750 Vac					750 Vac					750 Vac		—	—					
Impulse Withstand Voltage	V _{imp}	8 kVac					8 kVac					8 kVac					8 kVac		—	—					
Operational Voltage	V _e	690 Vac					690 Vac					690 Vac					690 Vac		—	—					
Sensor Rating	I _n	150 A					250 A					400 A					600 A		—	—					
Utilization Category	—	A					A					A					A		—	—					
Operations (Open-Close Cycles)																									
Without Current		4000					5000					5000					5000					—			
With Current		4000					1000					1000					1000					—			
Protection and Measurements																									
Short-circuit protection	Magnetic only	X	X	X	X	X	X	X	X	X	X	X	X	X	X	X	X	X	X	X	X	—	—		
	Thermal-magnetic	X	X	X	X	X	X	X	X	X	X	—	—	—	—	—	—	—	—	—	—	X	X		
	Electronic	X	X	X	X	X	X	X	X	X	X	X	X	X	X	X	X	X	X	X	X	—	—		
	with neutral protection (Off-0.5-1-OSN) ⁵	X	X	X	X	X	X	X	X	X	X	X	X	X	X	X	X	X	X	X	X	—	—		
	with ground fault protection	X	X	X	X	X	X	X	X	X	X	X	X	X	X	X	X	X	X	X	X	—	—		
with zone selective interlocking (ZSI) ⁶	X	X	X	X	X	X	X	X	X	X	X	X	X	X	X	X	X	X	X	X	—	—			
Display / I, V, f, P, E, THD measurements / interrupted-current measurement		X	X	X	X	X	X	X	X	X	X	X	X	X	X	X	X	X	X	X	X	—	—		
Options	Front display module (FDM121)	X	X	X	X	X	X	X	X	X	X	X	X	X	X	X	X	X	X	X	X	—	—		
	Operating assistance	X	X	X	X	X	X	X	X	X	X	X	X	X	X	X	X	X	X	X	X	—	—		
	Counters	X	X	X	X	X	X	X	X	X	X	X	X	X	X	X	X	X	X	X	X	—	—		
	Histories and alarms	X	X	X	X	X	X	X	X	X	X	X	X	X	X	X	X	X	X	X	X	—	—		
	Metering Com	X	X	X	X	X	X	X	X	X	X	X	X	X	X	X	X	X	X	X	X	—	—		
Device status/control com	X	X	X	X	X	X	X	X	X	X	X	X	X	X	X	X	X	X	X	X	—	—			
Dimensions / Weight / Connections																									
Dimensions (Three-Pole Unit Mount) in. (mm)	Height	6.4 (163)					7.5 (191)					13.38 (340)					13.38 (340)					13.38 (340)			
	Width	4.1 (104)					4.1 (104)					5.51 (140)					5.51 (140)					5.51 (140)			
	Depth	3.4 (86)					3.4 (86)					4.33 (110)					4.33 (110)					4.33 (110)			
Weight - lb. (Kg)		4.8 (2.2)					5.3 (2.4)					13.2 (6.0)					13.7 (6.2)					13.7 (6.2)			
Connections / Terminations	Unit Mount	X					X					X					X					X			
	I-Line	X					X					X					X					—			
	Rear Connection	X					X					X					X					X ⁷			
	Plug-In	X					X					X					X					—			
	Drawout	X					X					X					X					—			
Optional Lugs		X					X					X					X					—			

1 H and J-frame breakers with Micrologic trip units available only with three poles. The HJ, HL and the J-Frame two pole circuit breakers are three pole modules.
 2 DC not available with PowerPact H, J or L-frame circuit breakers with Micrologic trip units.
 3 500 Vdc specific catalog numbers, ungrounded UPS systems only.
 4 I_{CS} for 600 A L-frame circuit breaker at 525 V is 19 kA.
 5 OSN: Over Sized Neutral protection for neutrals carrying high currents (e.g. 3rd harmonics).
 6 ZSI using restraint wires.
 7 Rear connection is not available for 700–1200 A four pole L-frame circuit breakers.

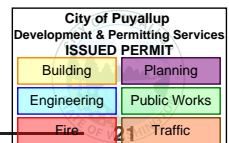

Table 9.18: QOB-GFI, QOB-EPD, and QOB-EPE Circuit Breakers

Ampere Rating ▲	1P		2P—Common Trip		3P—Common Trip	
	Catalog No.		Catalog No.		Catalog No.	Catalog No.
QOB-GFI—QOB QWIK-GARD® Circuit Breaker With Ground Fault Circuit Interrupter—UL Class A 4–6 mA People Protection. ■						
	120 Vac—10 k AIR		120/240 Vac—10 k AIR		208Y/120 Vac—10 k AIR	
15	QOB115GFI		QOB215GFI		QO315GFI	
20	QOB120GFI		QOB220GFI		QO320GFI	
25	QOB125GFI		QOB225GFI			
30	QOB130GFI		QOB230GFI		QO330GFI	
40			QOB240GFI		QO340GFI	
50			QOB250GFI		QO350GFI	
60			QOB260GFI ♦			
QOB-VHGF ★						
	120 Vac—22,000 AIR					
15	QOB115VHGF					
20	QOB120VHGF					
25	QOB125VHGF					
30	QOB130VHGF					
QOB-EPD—QOB Equipment protection circuit breakers with UL Listed 30 mA (EPD) or 100 mA (EPE) equipment protection.						
	120 Vac—10,000 AIR		240 Vac—10 k AIR			
15	QOB115EPD		QOB215EPD ♦		QO315EPE ♦	
20	QOB120EPD		QOB220EPD ♦		QO320EPE	
25	QOB125EPD		QOB225EPD			
30	QOB130EPD		QOB230EPD ♦		QO330EPE ♦	
40			QOB240EPD ♦		QO340EPE ♦	
50			QOB250EPD ♦		QO350EPE ♦	
60			QOB260EPD			
QOB-HM—High magnetic trip circuit breakers						
15	QOB115HM ▼					
20	QOB120HM ▼					
QOB-K—Key operated QOB circuit breakers △						
	120 Vac—10,000 AIR					
10	QOB110K					
15	QOB115K					
20	QOB120K					
25	QOB125K					
30	QOB130K					

(Footnotes for Tables 9.18, 9.19, and 9.20)

- ▲ 10–30 A circuit breakers are suitable for use with 60° C or 75° C conductors. 35–60 A circuit breakers are suitable for use with 75° C conductors.
- Do not connect to more than 250 feet of load conductor for the total one-way run to prevent nuisance tripping.
- ♦ Suitable only for feeding 240 Vac and 208 Vac two-wire loads. Does not contain load neutral connection.
- ★ Recommended for applications where high initial inrush may occur and for individual dimmer applications.
- ▼ UL Listed as SWD (switching duty) rated suitable for switching 120 Vac fluorescent lighting loads.
- △ Available in single pole construction and can be mounted in any single pole space which will accept a standard QOB. These circuit breakers can be turned ON or OFF or to RESET with a special key (Catalog No. QOK10) included with the circuit breaker. These circuit breakers are UL Listed and available as shown in the table.
- UL Listed for use on circuit feeding fluorescent and High Intensity Discharge (HID) lighting systems such as mercury vapor, metal halide, or high pressure sodium. These circuit breakers are physically interchangeable with QOB circuit breakers.
- ◇ UL Listed 5,000 AIR on 3Ø corner grounded delta systems.
- ☆ UL Listed as HACR type for use with air conditioning, heating and refrigeration equipment having motor group combinations and marked for use with HACR type circuit breakers.
- ▽ DC Rating is not available on indicated products.
- ⊙ QOB2150VH uses 4 pole spaces. QOB3110VH, QOB3125VH, and QOB3150VH each use 6 pole spaces. 40A maximum circuit breaker mounted opposite. Use with 75° C wire only.
- * For QO plug-on circuit breaker pricing, see tables starting on page 1–2.
- ◆ See note in Instruction Bulletin when using in an enclosure with a QO403 or QON prefix.

Table 9.21: QO/QOB Circuit Breaker Wire Sizes

Breaker Type	Ampere Rating ▲	Wire Size (AWG)	
		Al	Cu
QOB 1-pole	10–30	#14–8	#14–8
	10–30	—	two #14–10
	35–70	#8–2	#8–2
QOB 2-pole	10–30	#14–8	#14–8
	10–30	—	two #14–10
	35–70	#8–2	#8–2
QOB 3-pole	80–125	#4–2/0	#4–2/0
	150–200	#4–300 kcmil	#4–300 kcmil
	10–30	#14–8	#14–8
QOB-VH	35–70	#8–2	#8–2
	80–125	#4–2/0	#4–2/0
	110–150	#4–300 kcmil	#4–300 kcmil
QOT	15–20	#12–8	#14–8
QOB-GFI & QOB-EPD	15–30	#12–8	#14–8
	40, 50, 60	#12–4	#14–6

- ▲ 10–30 A circuit breakers are suitable for use with 60° C or 75° C conductors. 35–60 A circuit breakers are suitable for use with 75° C conductors.

Table 9.19: Standard Interrupting QOB 10,000 AIR Circuit Breakers

Ampere Rating ▲	One-pole		Two-pole—Common Trip		Two-pole—Common Trip ◇		Three-pole—Common Trip	
	Catalog No.		Catalog No.		Catalog No.		Catalog No.	
QOB Bolt-On								
	120 Vac—10 k AIR 48 Vdc—5 k AIR		120/240 Vac—10 k AIR 48 Vdc—5 k AIR ▼		240 Vac—10 k AIR		240 Vac—10 k AIR 48 Vdc—5 k AIR ▼	
10	QOB110		QOB210		—	—	QOB310	
15	QOB115 ▼		QOB215 ☆		QOB215H		QOB315 ☆	
20	QOB120 ▼		QOB220 ☆		QOB220H		QOB320 ☆	
25	QOB125 ☆		QOB225 ☆		QOB225H		QOB325 ☆	
30	QOB130 ☆		QOB230 ☆		QOB230H		QOB330 ☆	
35	QOB135 ☆		QOB235 ☆		—	—	QOB335 ☆	
40	QOB140 ☆		QOB240 ☆		QOB240H		QOB340 ☆	
45	QOB145 ☆		QOB245 ☆		—	—	QOB345 ☆	
50	QOB150 ☆		QOB250 ☆		QOB250H		QOB350 ☆	
60	QOB160 ☆		QOB260 ☆		QOB260H		QOB360 ☆	
70	QOB170 ☆		QOB270 ☆		QOB270H		QOB370 ☆	
80	—		QOB280 ☆ ▼		QOB280H		QOB380 ☆	
90	—		QOB290 ☆ ▼		QOB290H		QOB390 ☆	
100	—		QOB2100 ☆ ▼		QOB2100H		QOB3100 ☆	
110	—		QOB2110 ☆ ▼		—	—	—	
125	—		QOB2125 ☆ ▼		—	—	—	
Molded Case Switch 60 A max — 240 Vac			QOB200		—	—	QOB300	
Molded Case Switch 100 A max — 240 Vac			QOB2000		—	—	QOB3000	

Table 9.20: High Interrupting QOB and Specialty Circuit Breakers

Ampere Rating ▲	One-pole		Two-pole—Common Trip		Three-pole—Common Trip	
	Catalog No.		Catalog No.		Catalog No.	
QOB-VH						
	120 Vac—22,000 AIR		120/240 Vac—22,000 AIR		240 Vac—22,000 AIR	
15	QOB115VH ▼		QOB215VH ☆		QOB315VH ☆	
20	QOB120VH ▼		QOB220VH ☆		QOB320VH ☆	
25	QOB125VH ☆		QOB225VH ☆		QOB325VH ☆	
30	QOB130VH ☆		QOB230VH ☆		QOB330VH ☆	
40	—		QOB240VH ☆		QOB340VH ☆	
50	—		QOB250VH ☆		QOB350VH ☆	
60	—		QOB260VH ☆		QOB360VH ☆	
70	—		QOB270VH ☆		QOB370VH ☆	
80	—		QOB280VH ☆		QOB380VH ☆	
90	—		QOB290VH ☆		QOB390VH ☆	
100	—		QOB2100VH ☆		QOB3100VH ☆	
110	—		QOB2110VH ☆		QOB3110VH ☆	
125	—		QOB2125VH ☆		QOB3125VH ☆	
150	—		QOB2150VH ☆		QOB3150VH ☆	
QHB						
	120 Vac—65,000 AIR		120 Vac/240 Vac—65,000 AIR		240 Vac—65,000 AIR	
15	QHB115 ▼		QHB215 ☆		QHB315 ☆	
20	QHB120 ▼		QHB220 ☆		QHB320 ☆	
25	QHB125 ☆		QHB225 ☆		QHB325 ☆	
30	QHB130 ☆		QHB230 ☆		QHB330 ☆	
QOB-HID—HID circuit breakers □						
	120 Vac—10,000 AIR		120/240 Vac—10,000 AIR		240 Vac—10,000 AIR	
15	QOB115HID ▼		QOB215HID		QOB315HID	
20	QOB120HID ▼		QOB220HID		QOB320HID	
25	QOB125HID		QOB225HID		QOB325HID	
30	QOB130HID		QOB230HID		QOB330HID	
40	QOB140HID		QOB240HID		—	
50	QOB150HID		QOB250HID		—	
QOB-SWN—Switch Neutral—Common Trip—NEC 514.11						
			1-pole—2-Wire 2 Spaces—120 Vac		2-pole—3-Wire 3 Spaces—120/240 Vac	
10	—		QOB210SWN		QOB310SWN	
15	—		QOB215SWN		QOB315SWN	
20	—		QOB220SWN		QOB320SWN	
25	—		QOB225SWN		QOB325SWN	
30	—		QOB230SWN		QOB330SWN	
40	—		QOB240SWN		QOB340SWN	
50	—		QOB250SWN		QOB350SWN	

Table 9.22: QO® Arc-Fault Circuit Breakers ▲ ■

Circuit Breaker Type	Ampere Rating ▲	1P 120 Vac 10 kAIR 1 Space Required		1P 120 Vac 22 kAIR 1 Space Required	
		Catalog Number		Catalog Number	
Combination Arc-Fault Interrupter	15	QOB115CAFI		QOB115VHCAFI	
	20	QOB120CAFI		QOB120VHCAFI	

Note: See page 7-12 for accessories.

- ▲ UL Listed as HACR type for use with air conditioning, heating and refrigeration equipment having motor group combinations and marked for use with HACR type circuit breakers.
- QO arc-fault circuit breakers provide branch feeder protection (i.e. QO115AFI) or combination protection (i.e. QO115CAFI) as required by the NEC and local code adoption, and comply with the 2011 National Electrical Code (NEC) and local code adoption, and 1699.
- ◆ 10–30 A circuit breakers are suitable for use with 60° C or 75° C conductors. 35–60 A circuit breakers are suitable for use with 75° C conductors.

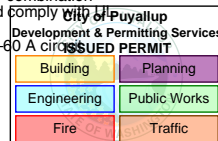



Circuit Breaker Type	HOM Circuit Breakers									QO® Circuit Breakers														
	Plug-on	HOM	HOM-AFI	HOM-GFI	HOM-EPD	HOMT	QO	QO-H	QO-VH	QH	QOT	QO-CAFI	QO-VHAFI	QO-GFI	QO-VHGF	QO-EPD QO-EPE								
	Bolt-on	—	—	—	—	—	QOB	QOB-H	—	—	—	QOB-VH	QHB	—	QOB-CAFI	QOB-VHAFI	QOB-GFI	QOB-VHGF	QOB-EPD QOB-EPE					
Unit Mount	—	—	—	—	—	—	—	—	—	—	—	—	—	—	—	—	—	—	—					

Number of Poles	1	2	1	1	2	1	2	1	1	2	3	2	1	2	3	1,2,3▲	1,2	3	1	1	1	2	3	1	1	2	3
Current Range	15-50	15-200♦	15-20	15-20	15-50	15-20	15-50	15-50■	10-70	10-200♦	10-100	15-100	15-30	15-125	15-100	15-30	15-30	15-30	15-20	15-30	15-30	15-60	15-50	15-30	15-30	15-60	15-50

Interrupting Ratings		10	10	10	10	10	10	10	10	10	10	10	22	22	22	22	22	65	65	10	10	22	10	10	—	22	10	10	—
UL/CSA Rating (kA) (50/60 Hz)	120 Vac	10	10	10	10	10	10	10	10	10	10	10	22	22	22	22	22	65	65	10	10	22	10	10	—	22	10	10	—
	120/240 Vac	10	10	—	—	10	—	10	10	10	10	10	22	22	22	22	22	65	65	10	—	—	—	10	—	—	—	10	—
	208Y/120	—	—	—	—	—	—	—	—	—	—	—	—	—	—	—	—	—	—	—	—	—	—	—	—	—	—	—	—
	240 Vac ★	—	—	—	—	—	—	—	—	—	—	10	10	—	—	22	—	22▼	—	65	—	—	—	—	—	—	—	—	10
	277 Vac	—	—	—	—	—	—	—	—	—	—	—	—	—	—	—	—	—	—	—	—	—	—	—	—	—	—	—	—

Special Ratings		X	X	X	X	X	X	X	X	X	—	—	—	X	—	—	—	X	—	X	X	—	X	—	—	—	X	—
Fed. Specs W-C-375B/GEN		X	X	X	X	X	X	X	X	X	—	—	—	X	—	—	—	X	—	X	X	—	X	—	—	—	X	—
Other Standard	HACR ◊ NOM	HACR ◊				HACR★ NOM			HACR ★				—	—	—	HACR ★	—	NOM	—	—	NOM	—	—	—	—	—	—	

Accessories and Modifications		—	—	—	—	—	—	—	—	X	X	X	X	X	X	X	X	X	X	X	X	X	X	X	X	X	X	X	X
Shunt Trip ▽		—	—	—	—	—	—	—	—	X	X	X	X	X	X	X	X	X	X	X	X	X	X	X	X	X	X	X	X
Undervoltage Trip		—	—	—	—	—	—	—	—	—	—	—	—	—	—	—	—	—	—	—	—	—	—	—	—	—	—	—	—
Auxiliary Switches ▽		—	—	—	—	—	—	—	—	X	X	X	X	X	X	X	X	X	X	X	X	X	X	X	X	X	X	X	X
Alarm Switch ▽		—	—	—	—	—	—	—	—	X	X	X	X	X	X	X	X	X	X	X	X	X	X	X	X	X	X	X	X
Handle Operators		—	—	—	—	—	—	—	—	—	—	—	—	—	—	—	—	—	—	—	—	—	—	—	—	—	—	—	—
Handle Padlock Attachment		X	X	X	—	—	—	—	X★	X	X	X	X	X	X	X	X	X	X	X	X	X	X	X	X	X	X	X	X

Trip System Type		X	X	X	X	X	X	X	X	X	X	X	X	X	X	X	X	X	X	X	X	X	X	X	X	X	X	X	X
Thermal-magnetic		X	X	X	X	X	X	X	X	X	X	X	X	X	X	X	X	X	X	X	X	X	X	X	X	X	X	X	X
Molded Case Switch		—	—	—	—	—	—	—	—	X	X	X	—	—	—	—	—	—	—	—	—	—	—	—	—	—	—	—	—

Dimensions (1P Unit Mount)		Height	3.13 (79)	3.5 (89) ▲	4.75 (121)	4.12 (103)
Dimensions (1P Unit Mount) in. (mm)	Width	1.00 (25)	0.75 (19) ▲	2.92 (74) ▲		
	Depth	2.98 (76)				
Pages		Page 1-13	Pages 7-10, 7-11			

- ▲ See page 7-54 for dimensions for: QOB2150VH, QOB3110VH, QOB3125VH and QOB3150VH.
- HOMT tandem is 30 A maximum. HOMT quad tandem has 20 A maximum on outside poles, and 50 A maximum on the inside poles.
- ◆ AFI, EPD and GFI products are rated 60 Hz only.
- ★ See the Supplemental Digest for 3Ø corner grounded systems.
- ▼ 22 kA @ 240 Vac for 3P only.
- △ 1P and 2P, 10-70 A and 3P 10-60 A only.
- See the Supplemental Digest for circuit breakers with IEC ratings.
- ◊ HACR on HOM 1P 15-50 A and 2P 15-100 A
- ☆ HACR on QO, QOB 1P 10-70 A, 2P 15-100 A, 3P 10-100 A; QOB-VH 1P 15-70 A, 2P 15-125 A, 3P 15-100 A
- ▽ Factory-installed option only
- ⊙ Factory-installed accessories are not available on QOB-VH 2P150 A and 3P 110-150 A
- * Handle padlock attachment available for HOMT quad tandem only.
- ◇ 2P 150-200 A requires 4P width.

7 MINIATURE AND MOLDED CASE CIRCUIT BREAKERS

City of Puyallup
Development & Permitting Services
ISSUED PERMIT

Building	Planning
Engineering	Public Works
Fire	Traffic



LED LUMINAIRES

Halco LED Linear Vaportight HLVT Series



DLC Premium



UL Rated



RoHS Compliant



5 YR WARRANTY
5 Year Warranty



Dimmable



IP66 Rated

Halco's Linear Vaportight – HLVT Series offers outstanding value and features long lasting reliability. The product is easy to install, featuring stainless steel clips, tethered LED boards, and multiple mounting options. It is the ideal industrial solution aimed to meet demanding environment needs. The lens is designed to provide visual comfort while delivering the efficient light output. The HLVT Series is guaranteed to deliver immediate energy savings and low maintenance costs. This easy-to-install vaportight is a low-cost solution rated for wet locations and stands up to the elements with its IP66 rating.



Water tight, IP66 Rated

Durable, Impact Resistant Housing

Quick, Tool-less Entry

0-10V Dimmable

Designed for Easy Installation

High Penetration Lens with Prism Design and Ray Concentration

Stainless Steel Hasps and Clips

Applications:

- Utility Lighting
- Parking Garage
- Stairwell Lighting
- Low Bay Lighting
- Manufacturing/Task Lighting

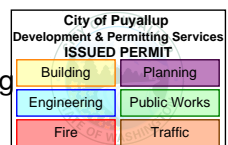

Contact Your Customer Care Specialist For Pricing, Orders And Technical Support.

800.677.3334 www.halcolighting.com

Halco LED Linear Vaportight HLVT Series

Product #: _____ Type: _____

Project: _____ Date: _____

Comments: _____ Initials: _____

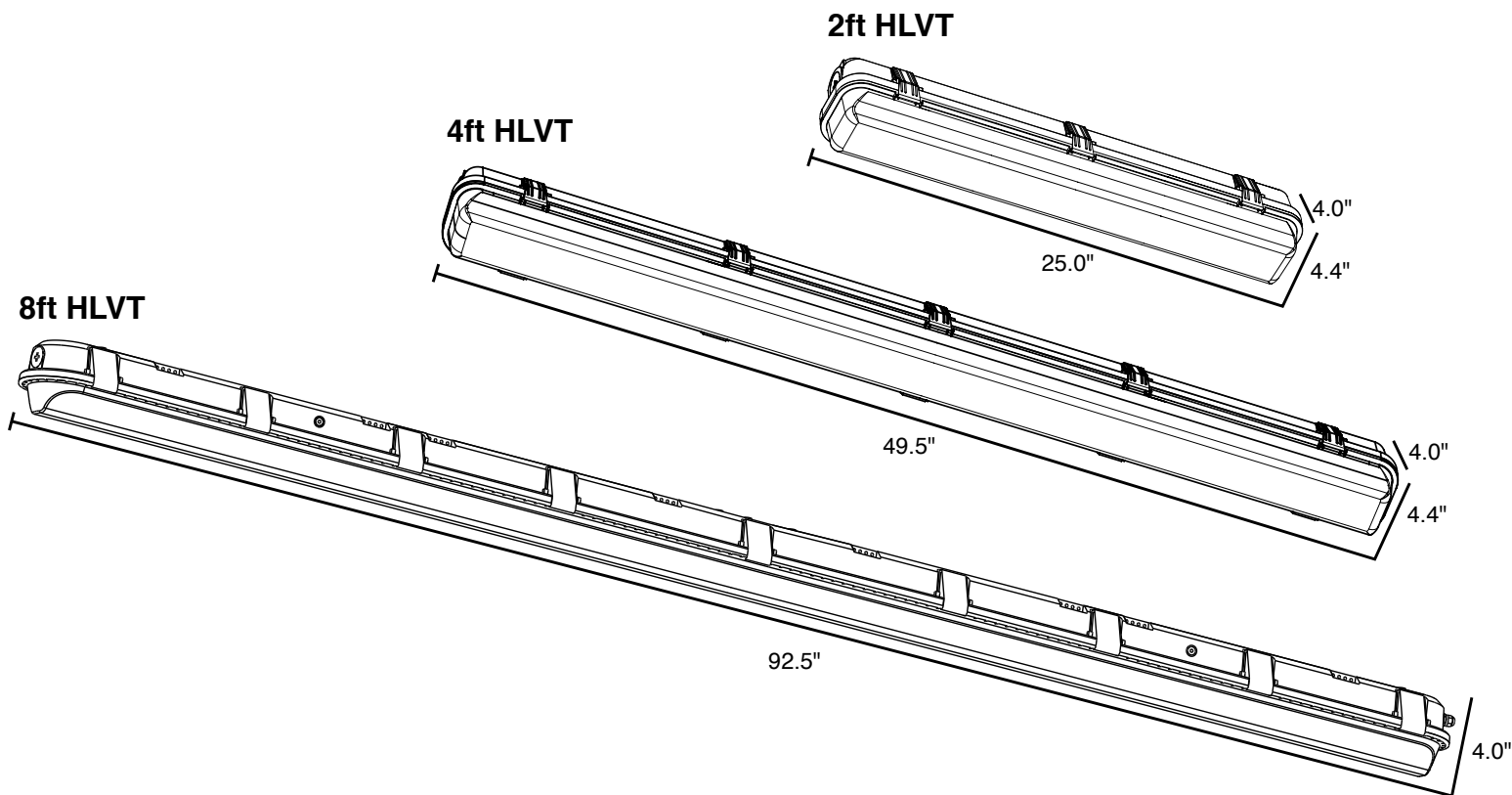

Performance

- LEDs are rated for greater than 100,000 hour life with calculated lumen maintenance >70% (L70) at 25°C.
- 0-10V dimmable driver standard available in 120-277V
- -40° To +55°C ambient operating temperature
- Power factor > 0.9
- 4kV surge protection

Design

- Designed for the harshest elements: tamperproof, waterproof, corrosion proof, and inset-proof
- Tethers connect the housing to the LED Board
- High Penetration Lens with Prism Design and Ray Concentration

Construction

- Durable, 5VA Impact-Resistant Polycarbonate Housing
- Stainless Steel Clips for Toolless Entry
- Non-Corrosive Polycarbonate Housing
- Completely Gasketed to maintain a true vaportight form

Environment

- IP66 rated
- UL wet location listed
- Rohs compliant
- Meets FCC part 15, subpart b, class a standards for conducted and radiated emissions

Certification

- All luminaires are built to UL 1598 standards, and bear appropriate culus labels for wet location
- DLC® (designlights consortium) premium qualified - see www.Designlights.Org
- IP66

Options

- Aircraft Cables
- Cord and Plug Assembly
- Microwave Multi-Level Motion Sensors
- Emergency Battery Backup

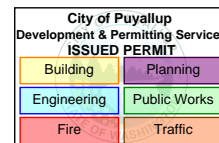

Ordering Information

Product Code	Product Number	Product Description	Wattage	Color Temp.	CRI	Voltage
HLVT2/25U40	10314	LINEAR VAPORTIGHT 2FT; 25W, 120-277V, 4000K	25W	4000K	80	120-277V
HLVT2/25U50	10315	LINEAR VAPORTIGHT 2FT; 25W, 120-277V, 5000K	25W	5000K	80	120-277V
HLVT4/40U40	10316	LINEAR VAPORTIGHT 4FT; 40W, 120-277V, 4000K	40W	4000K	80	120-277V
HLVT4/40U50	10317	LINEAR VAPORTIGHT 4FT; 40W, 120-277V, 5000K	40W	5000K	80	120-277V
HLVT8/72U40	10355	LINEAR VAPORTIGHT 8FT; 72W, 120-277V, 4000K	72W	4000K	80	120-277V
HLVT8/72U50	10356	LINEAR VAPORTIGHT 8FT; 72W, 120-277V, 5000K	72W	5000K	80	120-277V

Please Contact a Halco Representative for more information

Cord Set Options are assembled to order. Lead times apply. Battery Backup Option is Assembled to Order. Lead times apply.

Motion Sensor options are assembled to order. Lead times apply.

Halco Lighting Technologies 2940 Pacific Drive I Norcross, GA 30071 I Toll Free 800.677.3334 I Phone 770.242.3612 I Fax 800.880.0822 I halcolighting.com I Atlanta I Chicago I Cleveland I Houston I Los Angeles I Phoenix
© 2019 Halco Lighting Technologies, LLC. All rights reserved. Halco and ProLED are registered trademarks of Halco Lighting Technologies. All sizes and specifications are subject to change.

Halco LED Linear Vaportight HLVT Series

Product #: _____ Type: _____

Project: _____ Date: _____

Comments: _____ Initials: _____

Specification Table

Rated Wattage	25	40	72
Energy Savings	2x 17W T8	3x 32W T8	2 x 59W T8
Power Factor	> 0.9		
L70 Lifetime*	>100,000 hrs		
Input Voltage	120-277VAC		
Total Harmonic Distortion (THD)	< 15		
Surge Protection	4kV surge suppression protection tested in accordance with IEEE/ANSI C62.41.2		
Optical Distribution	110		
Mounting Options	Surface Mount Standard		
CCT	4000K & 5000K available		
Warranty	Halco Standard 5 Year, 10 Year Available		
Finish	Gray		
Wet	IP65 and UL Wet Listing		
DLC	DLC Premium		

*Useful Life is defined as the point in time at which the lamp will maintain at least 70% of its initial lumens. The lamp will continue to operate past this point at decreased light levels.. **IP rated as "dust tight" and protected against water projected from a nozzle. May not be compatible with all dimming systems, dimming performance may vary by system.
Warranty – Commercial / Industrial: This product is warranted for 5 years from the date of purchase. ** Check the latest update at www.DesignLights.org for listed product catalog numbers. Not all versions are listed.

Scaled Performance Data

Rated Wattage	Scaled CRI	Rated Frequency	Power Factor	4000K		5000K	
				Scaled Lumens	Scaled Efficacy	Scaled Lumens	Scaled Efficacy
25W	80	50/60Hz	0.9	3352	134	3395	136
40W	80	50/60Hz	0.9	5348	134	5416	135
72W	80	50/60Hz	0.9	9734	135	9856	137

Accessories

Ordering Code	Product Number	Product Code	Product Description
Aircraft Cable Kit	ACC/12IN	10311	AIRCRAFT CABLE KIT; 12 INCHES, 2 PER SET
Battery Backup	BBU/EM8WU	10310	BATTERY BACKUP; EMERGENCY 8W, 120-277V, LIFEP04 BATTERY, 90 MINUTE BACKUP

Mounting Included

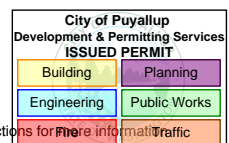
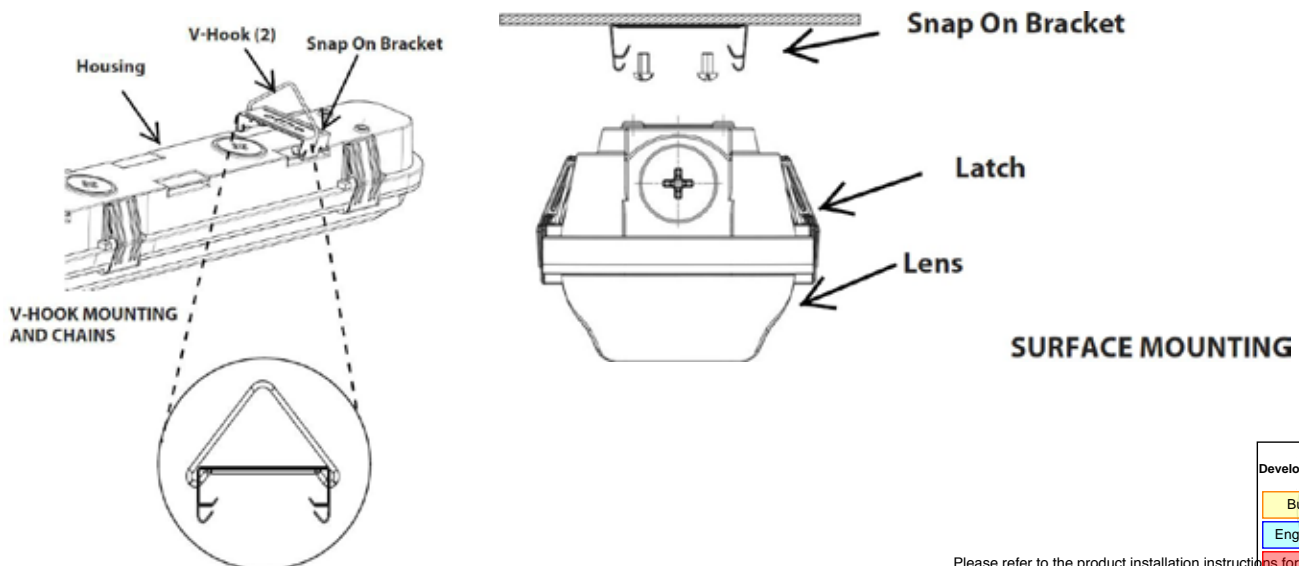

Please refer to the product installation instructions for more information.

Halco LED Linear Vaportight HLVT Series

Product #: _____ Type: _____

Project: _____ Date: _____

Comments: _____ Initials: _____

Photometric Report

Please Download ies Reports for complete photometric data.

LEGEND

- 0.25 fc
- 0.5 fc
- 1 fc
- 2 fc
- 5 fc

25 WATT

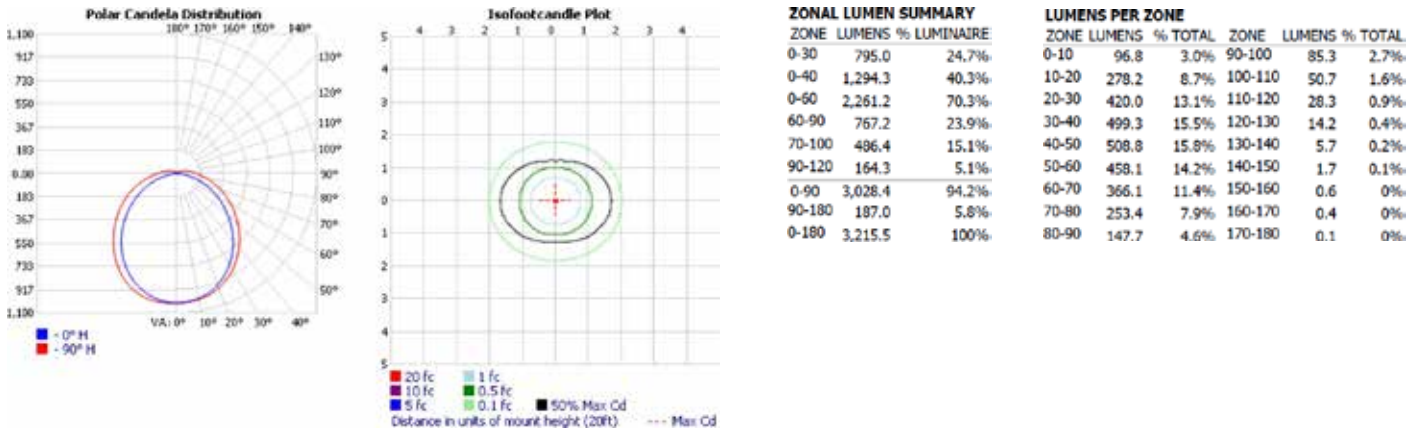

40 WATT*

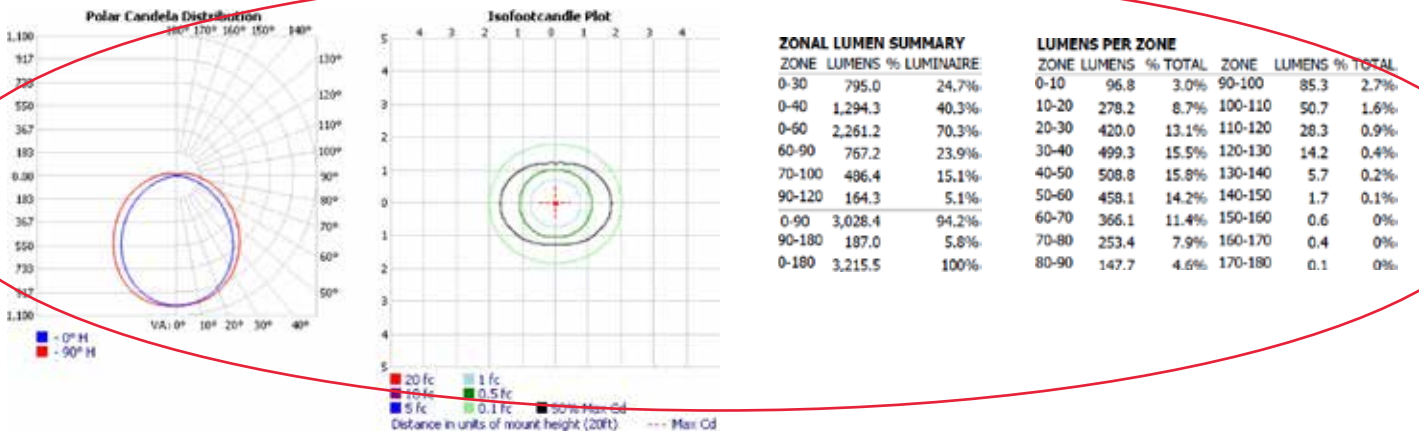

72 WATT

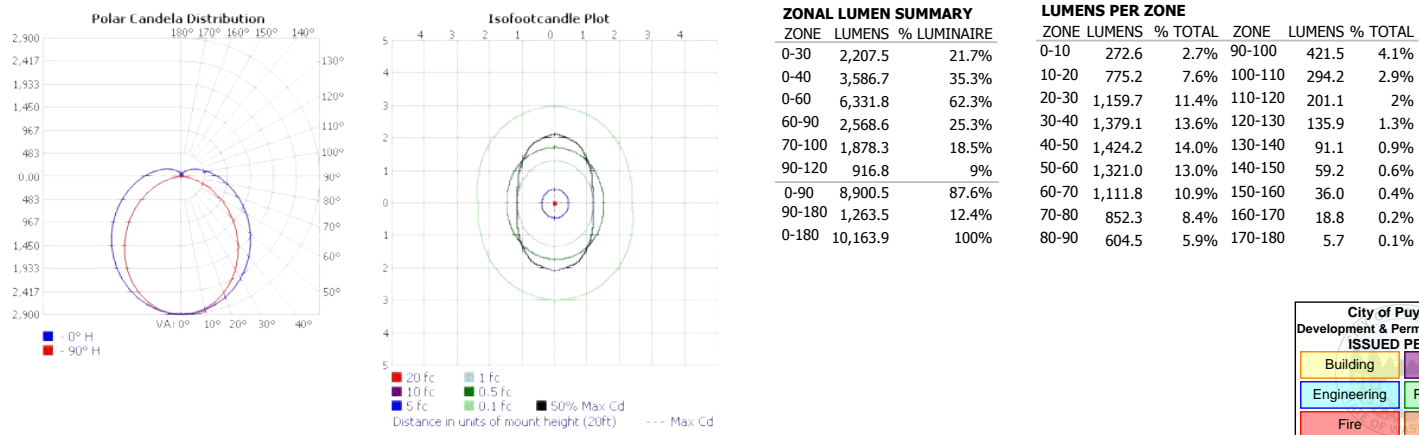

**City of Puyallup
Development & Permitting Services
ISSUED PERMIT**

Building	Planning
Engineering	Public Works
Fire	Traffic



Pass and Seymour
Industrial Extra Heavy Duty Specification Grade Switch, White
 Part No. PS20AC3W



3-Way Toggle Switch, Back and Side-Wire, 20A 120/277V

Features & Benefits

One-piece toggle molded from chemical-, impact-, and heat-resistant thermoplastic.

Glass-reinforced, chemical-resistant thermoplastic back body for durability, strength, and resistance to harsh cleaners.

Auto-ground clip assures positive ground.

Heavy-duty bumpers for quiet, smooth operation.

Oversized silver-alloy contacts for long life and better heat dissipation.

Heavy-duty, brass alloy, one-piece contact arm virtually eliminates contact bounce.

Shallow design for easier installation.

For compatible wall plate options, from our TradeMaster unbreakable plates to our radiant screwless plates to our metal wall plates, [click here](#).

Impact- and chemical-resistant cover.

One-piece nickel-plated brass strap for superior corrosion-resistance.

Cam control and spring actuator for positive "makes and breaks."

Locking support provides resistance to face and back body separation.

Side and external screw-pressure-plate back wire with #14 - #10 AWG copper or copper-clad wire.

Grounding terminal is standard with screw-pressure plate back wire.

For covering patents, see www.legrand.us/patents.

Specifications

General Info

Product Line	Pass & Seymour	Color	White
UPC Number	785007195446	Country Of Origin	Mexico
Application Sector	Industrial	Standard	UL 498/20

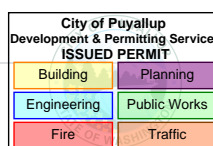

Listing Agencies / 3rd Party Agencies

cULus ListingNumber	140597	cULus Listed	Yes
---------------------	--------	--------------	-----

Technical Information

Actuator	Toggle	Contact Rating	20Amp, 120/277Vac
----------	--------	----------------	-------------------

Amperage	20 A	Action	Three pole
----------	------	--------	------------

Number of Poles	3-Way	Voltage	120 V
-----------------	-------	---------	-------

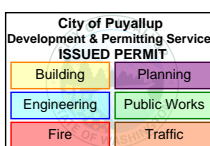



radiant Collection
radiant® Spec Grade 20A Tamper Resistant Self Test GFCI Receptacle, White
 Part No. 2097TRW



GFCI receptacles from the radiant® Collection self-test automatically every three seconds to ensure reliable protection from shock due to ground fault occurrences. Meeting National Electrical Code requirements for ground fault protection, GFCI receptacles make it easier to recognize and fix trips right where they happen – no more confusion at the breaker box. 20A outlets are ideal for use with larger appliances and in commercial settings, as well as to meet regional requirements (Chicago, Canada). GFCI protection is required by code in bathrooms, kitchens, garages, basements, outdoor areas, and for any other outlets found within six feet of a sink or water source. GFCI outlets should always be used when replacing existing GFCI outlets during renovation. Made exclusively for use with screwless Wall Plates from the radiant® Collection, sold separately. Spec-Grade devices are engineered to meet federal specifications for use in commercial installations.

Features & Benefits

- Protects against shock caused by ground-fault occurrences. Unlike breaker alternatives, GFCI receptacles make it easier to fix trips with a reset button right on the device.
- Equipped with proven SafeLock protection feature: if critical components are damaged and protection is lost, power to the outlet is disconnected.
- Protects children with a patented tamper-resistant shutter system that prevents improper insertion of foreign objects, complete with "invisi-shutters" for an invisible effect.
- Features durable, high-impact resistant thermoplastic construction.
- Complete the look with a sleek, screwless radiant® Wall Plate, and coordinate with other designer switches and outlets available from the radiant® Collection.
- 10kA short circuit rating
- Conducts an industry-leading automatic self-test every 3 seconds. If the device ever fails, the indicator light flashes to signal it should be replaced.
- Extends GFCI protection to "downstream" outlets when used with feed-thru wiring configuration. Note: Will cut power to face and downstream outlets if wired incorrectly.
- Replaces any standard receptacle with ease, in as little as 10 minutes.
- More color options available to fit any style, including finishes to match current hardware and lighting trends.
- Supplied with matching TP wall plate (except NI and DB models)
- 20 Amp feed-thru capacity

Specifications

General Info

Product Line	Pass & Seymour	Color	White
Finish	Matte	UPC Number	7850070358
Country Of Origin	China	Number of Receptacles	2
Outlet Type	Residential, Indoor, GFCI, Tamper-Resistant, Self-Test	Type	Outlet

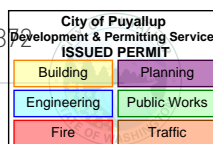

Listing Agencies / 3rd Party Agencies

cULus Listed Yes

Additional Information

Prop 65 Warning Required No Product Environmental Profile Yes

Technical Information

Number of Gangs 1 Amperage 20 A

Number of Poles Double Pole Indoor/Outdoor Indoor

NEMA Configuration Code 5-20R Mounting Type Box

Voltage 125 VAC Environmental Conditions 95% Humidity, UL
94 V2

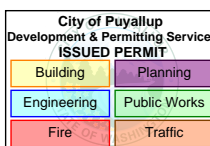

Electric Utility Heater

HVAC/R fact sheet



Electric Utility Heater, 5/4.1 kW

Ideal for Auxiliary, supplementary or primary heat source in factories, stores, garages, basements, warehouses, public buildings, service stations, stockrooms, offices, workshops, toll booths, closing offices, large or exposed areas or additions. Heater comes equipped with ceiling mounting bracket for horizontal or vertical flow mounting or any position in between.

CATALOG NUMBER	VOLTS	WATTS	BTU PER HR.	PHASE	HP or FAN MOTOR WATTS	FAN MOTOR RPM	AIR VOLUME CFM	THROW	MIN. MTG. HT.	HEATER AMPS	WT. (LBS.)
Electric Utility Heater											
3UG73	208	1874	6396	1	6	1350	270	16'	6'	9.0	24
		2500	8553							12.0	
		3123	10659							15.0	
	240	3750	12799							18.0	
		2500	8533							10.4	
		3332	11365							13.9	
		4165	14215							17.4	
5000	17065	20.9									



Electric Utility Heater, 5/4.1/3.3/2.5 kW

Ideal for Auxiliary, supplementary or primary heat source in factories, stores, garages, basements, warehouses, public buildings, service stations, stockrooms, offices, workshops, toll booths, closing offices, large or exposed areas or additions. Heater comes equipped with ceiling mounting bracket for horizontal or vertical flow mounting or any position in between.

CATALOG NUMBER	VOLTS	WATTS	BTU PER HR.	PHASE	HP or FAN MOTOR WATTS	FAN MOTOR RPM	AIR VOLUME CFM	THROW	MIN. MTG. HT.	HEATER AMPS	WT. (LBS.)
Electric Utility Heater											
3UG74	208	2500	8533	1	6	1350	270	16'	6'	10.4	24
		3332	11365							13.9	
		4165	14215							17.4	
		5000	17065							20.9	

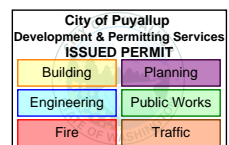

Exclusively from Grainger.

Call or visit your local branch or go to grainger.com/dayton for complete product line information

Skirtboard - SBR Rubber - 70A

Specifications
March 2012

<u>Description:</u>	Skirtboard is a sturdy sheet product designed for use as conveyor skirtboard or belt wiper.
<u>Compound:</u>	SBR
<u>Color:</u>	Black
<u>Weight:</u>	Approximate weight per square foot: 1/8" weighs 1 lb.
<u>Durometer:</u>	65-75
<u>Temperature Range:</u>	-10 F to 190 F
<u>Minimum Tensile:</u>	725 PSI or 5 MPA
<u>Finish:</u>	Smooth
<u>Minimum Elongation:</u>	300%
<u>Gauges:</u>	1/8", 1/4", 3/8", 1/2", 3/4", 1", 1.5" (custom gauges up to 2" thick are available upon request)
<u>Widths:</u>	4", 6", 8", 10", 12", 36", 48" (custom widths up to 78" are available upon request)
<u>Roll Length:</u>	25 or 50ft.
<u>Chemical Resistance:</u>	Good resistance to Ethanol, Formaldehyde, Glycerin, Sea Water, Boric Acid, and Chlorine Solutions. Not suited for use with Oils, Fuels, Solvents, or Hydraulic Fluids. For Skirtboard's compatibility with your specific medium please consult a Rubber-Cal representative.
<u>Applications:</u>	Street Sweepers, Abrasion Resistant Applications, Snowplow Blades, Airfield Applications, General Industrial Padding and Gasketing
<u>Flexibility:</u>	This hard durometer (65-75) sheet rubber offers limited pliability and elasticity.
<u>Custom Cuts:</u>	In addition to hand fabrication, this product can be fabricated using laser, die, and water-jet cut. Please submit your drawings for a price quote.
<u>Availability:</u>	Popular gauges and widths and stock.

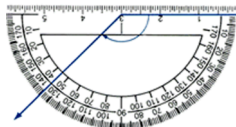

Rubber Cal

Specifications and/or prices are subject to change without prior notice.

© 2014 Rubber-Cal all rights reserved.

Rubber-Cal, Inc.
620 West Warner Ave
Santa Ana, CA 92707
800-370-9152
www.rubbercal.com

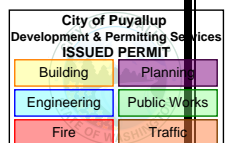

GENERATOR DATA
GENSET MODEL#: MTU DS1250
VOLTAGE: 480 V
RATING: 1250 KW
OVERALL DIMENSIONS: 199.2"L x 91.4"W x 97.7"H

AIR VELOCITY
RADIATOR COOLING AIR: 60,350 CFM
COMBUSTION AIR: 3,814 CFM
ENCLOSURE:
INTAKE VELOCITY: 1056 ft/min
DISCHARGE VELOCITY: 1191 ft/min

WEIGHTS
GENSET: 21,000 LBS
TANK: 21,500 LBS (DRY)
ENCLOSURE: 17,500 LBS



1965 BENNETT DRIVE DELAND, FL. 32724
 PHONE: 386-469-0070
 WEBSITE:
 WWW.COASTLINEPOWERSOLUTIONS.COM

SUBMITTAL PACKAGED FOR:

CERIO
 CENTERIS SEATTLE WA

PROJECT NUMBER: 20240161 1-5 DATE: 8/2/24

SUBMITTAL OUTLINE:
SHEET 1- COVER SHEET
SHEET 2- DESIGN CRITERIA
SHEET 3- PLAN VIEW
SHEET 4- RIGHT SIDE ELEVATION
SHEET 5- END VIEWS
SHEET 6- PAD LAYOUT
SHEET 7- PAD LAYOUT
SHEET 8- ELECTRICAL DIAGRAM
SHEET 9- LIFTING DIAGRAM
SHEET 10- STAIR & PLATFORMS
SHEET 11- STAIR & PLATFORMS

SHIPPING NOTE:
 UNIT TO BE SHIPPED AS ONE PIECE(S).
 EXTRA TRUCK FOR SHIP LOOSE (IF APPLICABLE)

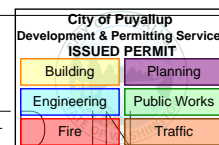

TANK DATA
TANK TYPE: ENVIROSHIELD GOLD
TANK TOTAL CAPACITY: 7,300 GAL
SECONDARY WETTED SQFT AREA: 671 SQFT
SECONDARY TANK DIMENSIONS: 366"L x 132"W x 37"H
PRIMARY WETTED SQFT AREA: 626 SQFT
PRIMARY TANK DIMENSIONS: 356.75"L x 122.75"W x 33.9"H

TANK FITTING LEGEND
F - 3" OVERFILL PREVENTION VALVE - 6" NPT
G - MECH. FUEL GAUGE - 2" NPT
D - LS600 (UL2200 COMPLIANT) - 2" NPT
S - FUEL SUPPLY - 2" NPT (W/1" DROP TUBE)
R - FUEL RETURN - 2" NPT (W/1" DROP TUBE)
DB - SPILL BOX DRAIN - 1/2" HALF COUPLING
V - MAIN VENT - 3" NPT
SV - SECONDARY EMERGENCY VENT - 8" NPT
PV - PRIMARY EMERGENCY VENT - 8" NPT
H - HIGH FUEL LEVEL SENSOR [MADISON M-7000 EQ#682] - 2" NPT
L - LOW FUEL LEVEL SENSOR [MADISON M-7000] - 2" NPT
SP - SPARE - 2" NPT
VP - SECONDARY VACUUM PORT - 1/2" NPT
PS - FUEL POLISHING SUPPLY - 2" NPT W/1" DROP TUBE
PR - FUEL POLISHING RETURN - 2" NPT W/1" DROP TUBE
CPS UL-142 DOUBLE WALL TANK & SPILL CONTAINMENT - [EQ#533]
*NOTES: 1. THIS IS A STANDARD LEGEND, SOME FITTINGS MAY NOT APPLY 2. TANK FITTING SIZES SHOWN ON PLAN ARE OPENING SIZES

ISOLATOR DETAIL
ISOLATOR PART#: AMC BRB 180
ISOLATOR QUANTITY: 10

REV.	DESCRIPTION:	DATE:	BY:	REVISIONS
1	ADDED DOCKING STATION, INCREASED LENGTH OF DOCKING STATION, INCREASED TANK CAPACITY, BASEFRAME, ADDED STAIR, PAD LAYOUT DETAIL	8/21/24	JRP	INCREASED THE SIZE OF THE DOCKING STATION TO 48 WIDE X 50.5 DEEP X 91 TALL
3	MIRRORED DOCKING STATION, TRANSFORMER, LOAD PANEL, AND DISCONNECT SWITCH TO OPPOSITE SIDES, MOVED STUB UP UNDER INCREASED STUB UP SIZE, ADDED REMOVABLE INCREASED STUB UP ACCESS PANEL, INCREASED STUB UP ACCESS PANEL, INCREASED HEIGHT OF TANK 1" FOR PROPER GALLONAGE	9/5/24	JRP	ADDED FUEL PUSHER, UPDATED ELECTRICAL DIAGRAM
4		9/6/24	JRP	

CUSTOMER:	CERIO	DATE:	8/02/24	REVIEWED BY:	JD/EJ	SCALE:	NTS
PROJECT:	CENTERIS SEATTLE WA	DRAWN BY:	JRP				

SEE COVER PAGE OF SUBMITTAL FOR ESTIMATED WEIGHTS AND DIMENSIONS

PROJECT #:	20240161
COMPONENT CAD DRAWINGS	---
1287	---
TITLE: COVER SHEET	---
SHEET: 1 OF 11	---

1965 BENNETT DRIVE DELAND FL 32724
 PHONE: 386-469-0070
 WEBSITE: WWW.COASTLINEPOWERSOLUTIONS.COM

DESIGN CRITERIA

5 ENCLOSURE AND SUB-BASE FUEL TANK FOR MTU DS1250 1250KW 16V2000 GENERATOR SET

COASTLINE POWER SOLUTIONS TO PROVIDE THE FOLLOWING:

WEATHER RESISTANT, LEVEL 3 SOUND ATTENUATED, ALUMINUM ENCLOSURE:

- ENCLOSURE EXTERIOR TO BE OF .080",3003-H14 ALUMINUM, FORMED, PANEL CONSTRUCTION, PRE-PAINTED FINISH (STANDARD COLOR WHITE).
- AIR INTAKE: SOUND ATTENUATED INTAKE HOOD WITH MOTORIZED CONTROL DAMPERS AND BIRD SCREEN. INSULATED WITH 3" SOUND ATTENUATING FIRE BLANKET RETAINED WITH .050" PERFORATED ALUMINUM.
- AIR DISCHARGE: SOUND ATTENUATED DISCHARGE HOOD WITH GRAVITY DAMPERS AND BIRD SCREEN. INSULATED WITH 3" SOUND ATTENUATING FIRE BLANKET RETAINED WITH .032" MILL FINISHED ALUMINUM.
- 3" SOUND ATTENUATING FIRE BLANKET IN WALLS AND CEILINGS. INSULATION RETAINED WITH .050" PERFORATED ALUMINUM. ENCLOSURE IS DESIGNED TO PROVIDE SOURCE SPL BY 75 DB (A) @ 7M IN A FREE-FIELD ENVIRONMENT.
- (4) 36" SINGLE, ACCESS DOORS WITH PADLOCKING PROVISIONS, PANIC RELEASE AND CORROSION RESISTANT HARDWARE.
- SILENCER SUPPORTS FOR CPS FURNISHED INTERIOR MOUNTED, INTERNALLY INSULATED, CRITICAL GRADE SILENCER.
- INSTALL CPS PROVIDED EXHAUST FLEX CONNECTORS, WITH THERMAL BLANKETS EXHAUST GASKETS AND BOLT KITS.
- INSTALL CPS PROVIDED EXHAUST DISCHARGE ELBOW, WITH THERMAL BLANKETS AND RAIN CAP.
- RAIN COLLAR AND RAIN SHIELD AT EXHAUST PENETRATION IN ROOF.
- EXTEND OIL AND COOLANT DRAINS TO EXTERIOR OF ENCLOSURE.
- EXTEND CRANK CASE DISPOSAL TO RADIATOR DISCHARGE (IF APPLICABLE)
- CAMBERED ROOF DESIGN TO AID IN WATER SHEDDING.
- ENCLOSURE SUITABLE FOR 150 MPH WIND LOADING
- PE CERTIFICATES CAN BE PROVIDED FOR AN ADDITIONAL CHARGE
- CERTIFICATES TO WASHINGTON L & I REQUIREMENTS.

GENERATOR ENCLOSURE ELECTRICAL PACKAGE:

- (1) 30KVA 480:120/208 3 PHASE TRANSFORMER WITH 60A FUSED DISCONNECT SWITCH WITH 50A FUSES.
- (1) 120/208V 3 PHASE MCB (100A MAIN BREAKER) PANEL BOARD WITH BOLT-ON BRANCH CIRCUIT BREAKERS.
- (4) 48" LED LIGHT FIXTURES WITH (2) SWITCHES LOCATED BY ENTRANCE DOORS.
- (2) 20A, 125V DUPLEX GFCI RECEPTACLE LOCATED BY ENTRANCE DOORS.
- (1) 5KW SPACE HEATER AND THERMOSTAT INSIDE ENCLOSURE.
- BATTERY SELECTOR SWITCH
- WIRE MOTORIZED LOUVERS/DAMPERS TO PANEL BOARD
- CUSTOMER PROVIDED ITEMS COASTLINE TO INSTALL/WIRE
- (1) DOCKING STATION CABINET WIRED TO GENERATOR MOUNTED OUTPUT BREAKER (ALL CONTROL WIRING TO BE PROVIDED BY OTHERS).
- WIRE JACKET WATER HEATERS TO PANEL BOARD.
- WIRE GENERATOR STRIP HEATERS TO PANEL BOARD.
- MOUNT AND WIRE BATTERY CHARGER TO PANEL BOARD AND DC OUTPUT FOR BATTERIES VIA TERMINATION ON STARTER.
- 2000A FLUSH MOUNTED DOCKING STATION
- ALL ELECTRICAL TO BE RUN IN EMT OR LFMC TO MEET NFPA 70.

7,300-GALLON CPS "ENVIROSHIELD GOLD" @ UL 142, SUBBASE FUEL TANK:

- CAPACITY BASED ON 72 HOURS @ 88GPH (100% LOAD) 6,396 USEABLE GALLONS
- 10GA MILD STEEL PRIMARY TANK, 1/4" THICK MILD STEEL SECONDARY TANK
- MECHANICAL FUEL LEVEL GAUGE (KRUEGER MODEL H)
- SUPPLY AND RETURN CONNECTIONS
- 3" FILL WITH LOCKABLE CAP WITH SPILL CONTAINMENT WITH OVERFILL PREVENTION VALVE
- NORMAL AND EMERGENCY VENT FITTINGS INSTALLED PER UL-142
- INTERSTITIAL SPACE WITH LEAK DETECTION SWITCH, WIRED TO GENERATOR CONTROL PANEL (FINAL TERMINATION TO TERMINAL STRIP TO BE DONE BY INSTALLING TECHNICIAN).
- HIGH LEVEL FUEL ALARM SWITCH, SET @ 90% TANK CAPACITY WIRED TO DAY TANK CONTROL PANEL (FINAL TERMINATION TO TERMINAL STRIP TO BE DONE BY INSTALLING TECHNICIAN).
- LOW LEVEL FUEL ALARM SWITCH, SET @ 35% TANK CAPACITY WIRED TO DAY TANK CONTROL PANEL (FINAL TERMINATION TO TERMINAL STRIP TO BE DONE BY INSTALLING TECHNICIAN).
- PROVIDE, MOUNT AND INSTALL (1) REVERSO (MODEL AFP-600) AUTOMATIC FUEL POLISHING SYSTEM
- CABLE STUB UP OPENING UNDER CIRCUIT BREAKER
- GENERATOR MOUNTING PADS
- 2 LIFTING POINTS PER SIDE (4 TOTAL) FOR LIFTING GENERATOR SET, ENCLOSURE AND TANK (EMPTY)
- TANK PRIMED WITH TWO PART EPOXY ZINC BASED PRIMER AND TWO-PART POLYESTER/POLYURETHANE TOPCOAT -GLOSS BLACK.

SHIP UNDER VACUUM:

- TANK SEALED AND SHIPPED UNDER VACUUM PER NFPA30.
- TANK VACUUM TO BE VERIFIED AND DOCUMENTED PER NFPA-30 IMMEDIATELY UPON RECEIPT AND PLACEMENT AT THE JOB SITE.

OSHA COMPLIANT STAIRS AND WALKWAYS:

- (2) SET OF OSHA COMPLIANT STAIRS WITH 240" LONG X 42" WIDE WALKWAY AND HANDRAILS.
- (4) SET OF OSHA COMPLIANT STAIRS WITH 240" LONG X 42" WIDE WALKWAY.
- STAIRS ON BOTH ENDS OF ALL PLATFORMS
- RAILINGS TO BE CONSTRUCTED OF 1 1/2" ALUMINUM TUBE.
- STEPS AND WALKWAYS CONSTRUCTED OF EXTRUDED ALUMINUM
- LEVELING PADS

SYSTEM INTEGRATION (UPFIT AT CPS FACILITY):

- UNLOAD CUSTOMER SUPPLIED GENERATOR SET AND COMPONENTS FROM TRUCKS.
- INSTALL GENERATOR TO SUPPORT FLOOR.
- PROVIDE GASKET MATERIAL BETWEEN ENCLOSURE AND SUPPORT FLOOR
- ATTACH ENCLOSURE, WITH SUPPORT FLOOR TO DOUBLE WALL BASE/ FUEL TANK.
- PLUMB FUEL TANK TO GENERATOR SET ENGINE.
- INSTALL CPS SUPPLIED EXHAUST SILENCER AND COMPONENTS.
- PROVIDE FOR SHIP LOOSE 4" X 1/4" NEOPRENE PADDING FOR INSTALLATION BETWEEN TANK AND PAD
- LOAD UNIT ONTO CUSTOMER PROVIDED TRUCKS FOR SHIPMENT.

CUSTOMER TO PROVIDE:

- MTU 1250KW ENGINE GENERATOR SET PACKAGE WITH FACTORY INSTALLED OPTIONS
- UNIT MOUNTED MAIN LINE CIRCUIT BREAKER
- BATTERY CHARGER
- WATER/FUEL SEPARATOR FILTER
- VIBRATION ISOLATORS

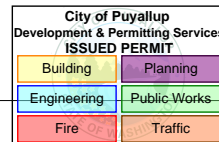

REVISIONS

REV.	DESCRIPTION:	DATE:	BY:	REV:	DESCRIPTION:	DATE:	BY:
1	ADDED DOCKING STATION, INCREASED LENGTH OF DOCKING STATION, INCREASED TANK BASEFRAME, ADDED STAIR, PAD LAYOUT DETAIL	8/21/24	JRP	5	INCREASED THE SIZE OF THE DOCKING STATION TO 48 WIDE X 50.5 DEEP X 91 TALL	9/6/24	JRP
3	MIRRORED DOCKING STATION, TRANSFORMER, LOAD PANEL, AND DISCONNECT SWITCH TO OPPOSITE SIDES, MOVED STUB UP UNDER INCREASED STUB UP SIZE, ADDED REMOVE STUB UP ACCESS PANEL, INCREASED HEIGHT OF TANK 1" FOR PROPER GALLONAGE	9/5/24	JRP	6	ADDED FUEL POLISHER, UPDATED ELECTRICAL DIAGRAM	1/25/21	JRP
4		9/6/24	JRP				

CUSTOMER:	CERIO	REVIEWED BY:	JD/EJ
PROJECT:	CENTERIS SEATTLE WA	DATE:	8/02/24
DRAWN BY:	JRP	SCALE:	NTS

SEE COVER PAGE OF SUBMITTAL FOR ESTIMATED WEIGHTS AND DIMENSIONS

PROJECT #:	20240161
COMPONENT CAD DRAWINGS	---
1287	---
TITLE: DESIGN CRITERIA	
SHEET: 2 OF 11	

1965 BENNETT DRIVE DELAND FL 32724
 PHONE: 386-469-0070
 WEBSITE: WWW.COASTLINEPOWERSOLUTIONS.COM

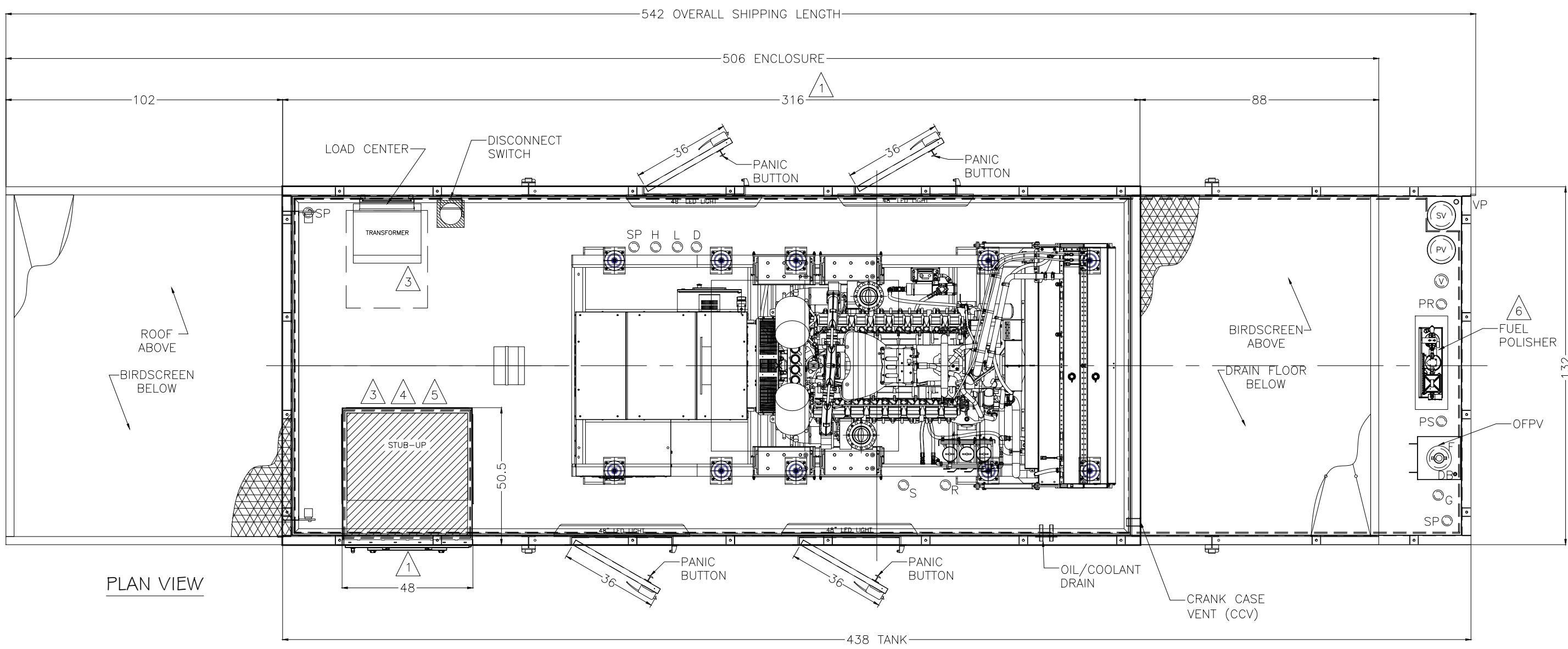

PLAN VIEW

City of Puyallup
Development & Permitting Services
ISSUED PERMIT

Building	Planning
Engineering	Public Works
Fire	Traffic

REVISIONS

REV.	DESCRIPTION:	DATE:	BY:
1	ADDED DOCKING STATION, INCREASED LENGTH OF TANK, INCREASED WIDTH OF BASEFRAME, ADDED STAIR, PAD LAYOUT DETAIL	8/21/24	JRP
2	INCREASED THE SIZE OF THE DOCKING STATION TO 48 WIDE X 50.5 DEEP X 91 TALL	9/6/24	JRP
3	MIRRORED DOCKING STATION, TRANSFORMER, LOAD PANEL, AND DISCONNECT SWITCH TO OPPOSITE SIDES, MOVED STUB UP UNDER INCREASED STUB UP SIZE, ADDED REMOVABLE STUB UP ACCESS PANEL, INCREASED HEIGHT OF TANK 1" FOR PROPER GALLONAGE	9/5/24	JRP
4	ADDED FUEL POLISHER, UPDATED ELECTRICAL DIAGRAM	9/6/24	JRP
6		1/25/21	JRP

CUSTOMER: CERIO
PROJECT: CENTERIS SEATTLE WA

DATE:	8/02/24	REVIEWED BY:	JD/EJ	SCALE:	NTS
DRAWN BY:	JRP				

SEE COVER PAGE OF SUBMITTAL FOR ESTIMATED WEIGHTS AND DIMENSIONS

PROJECT #: 20240161
COMPONENT CAD DRAWINGS
1287

TITLE: PLAN VIEW
SHEET: 3 OF 11

COASTLINE
POWER SOLUTIONS

1965 BENNETT DRIVE, DELAND, FL 32724
PHONE: 386-469-0070
WEBSITE: WWW.COASTLINEPOWERSOLUTIONS.COM

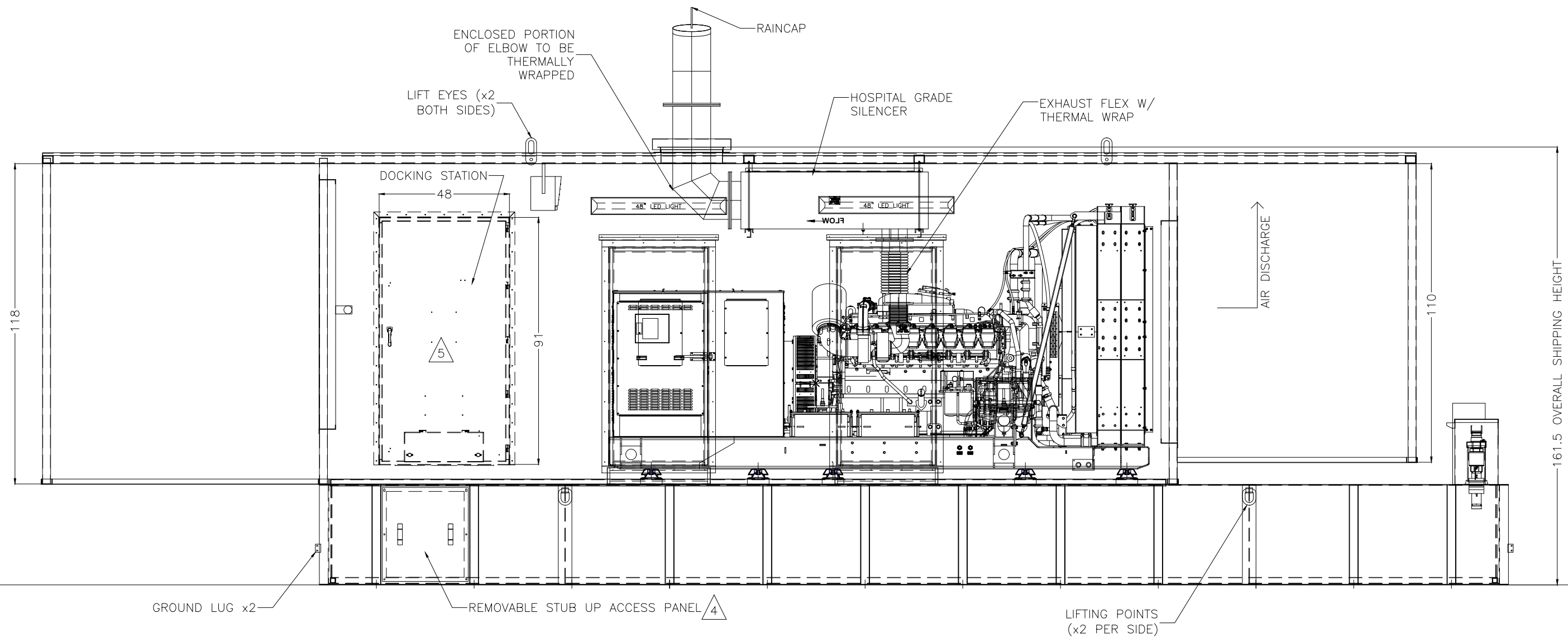

RIGHT SIDE ELEVATION

City of Puyallup
Development & Permitting Services
ISSUED PERMIT

Building	Planning
Engineering	Public Works
Fire	Traffic

REVISIONS

REV.	DESCRIPTION:	DATE:	BY:	REV:	DESCRIPTION:	DATE:	BY:
1	ADDED DOCKING STATION, INCREASED LENGTH OF DOCKING STATION TO 48 WIDE X 50.5 DEEP X 91 HIGH. ADDED STAIR, PAD LAYOUT DETAIL.	8/21/24	JRP	5	INCREASED THE SIZE OF THE DOCKING STATION TO 48 WIDE X 50.5 DEEP X 91 HIGH. ADDED STAIR, PAD LAYOUT DETAIL.	9/6/24	JRP
3	MIRRORED DOCKING STATION, TRANSFORMER, LOAD PANEL, AND DISCONNECT SWITCH TO OPPOSITE SIDES, MOVED STUB UP UNDER EXHAUST FLEX.	9/5/24	JRP	6	ADDED FUEL PUSHER, UPDATED ELECTRICAL DIAGRAM	1/25/21	JRP
4	INCREASED STUB UP SIZE, ADDED REMOVABLE STUB UP ACCESS PANEL, INCREASED HEIGHT OF TANK 1" FOR PROPER GALLONAGE.	9/6/24	JRP				

CUSTOMER:

CERIO

PROJECT:

CENTERIS SEATTLE WA

DRAWN BY:	DATE:	REVIEWED BY:	SCALE:
JRP	8/02/24	JD/EJ	NTS

SEE COVER PAGE OF SUBMITTAL FOR ESTIMATED WEIGHTS AND DIMENSIONS

PROJECT #:	20240161
COMPONENT CAD DRAWINGS	---
1287	---
TITLE: ELEVATIONS	---
SHEET: 4 OF 11	---

COASTLINE
POWER SOLUTIONS

1965 BENNETT DRIVE, DELAND, FL 32724
PHONE: 386-469-0070
WEBSITE: WWW.COASTLINEPOWERSOLUTIONS.COM

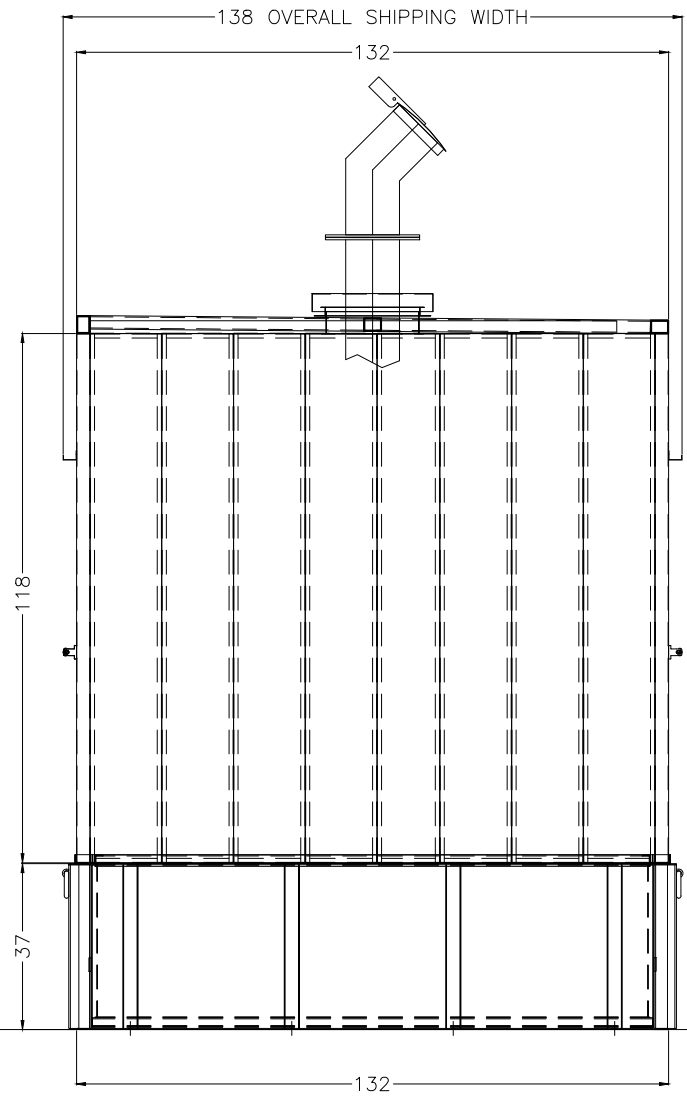

INTAKE END
W/ HOOD

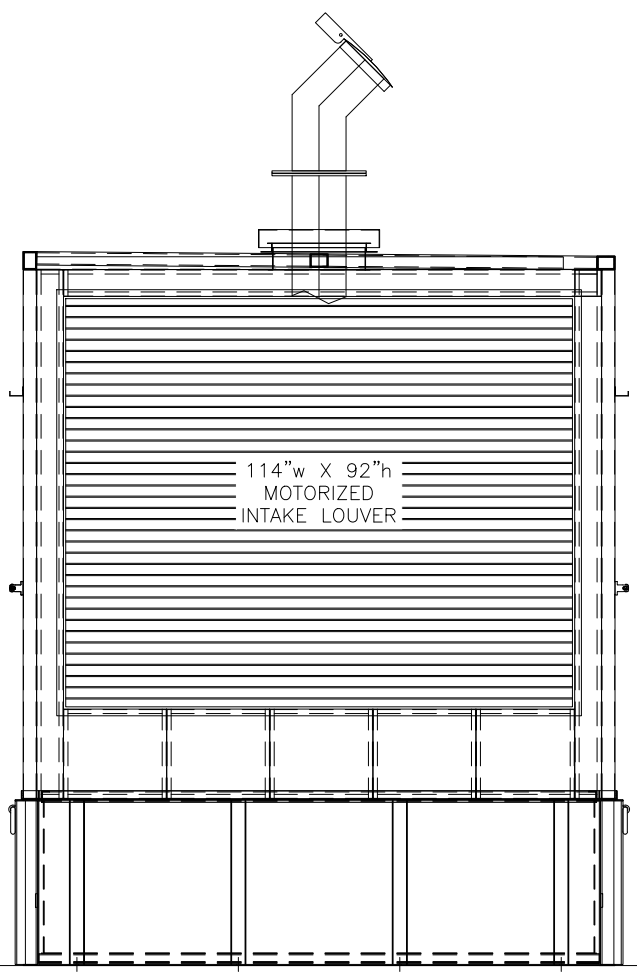

INTAKE END
W/O HOOD

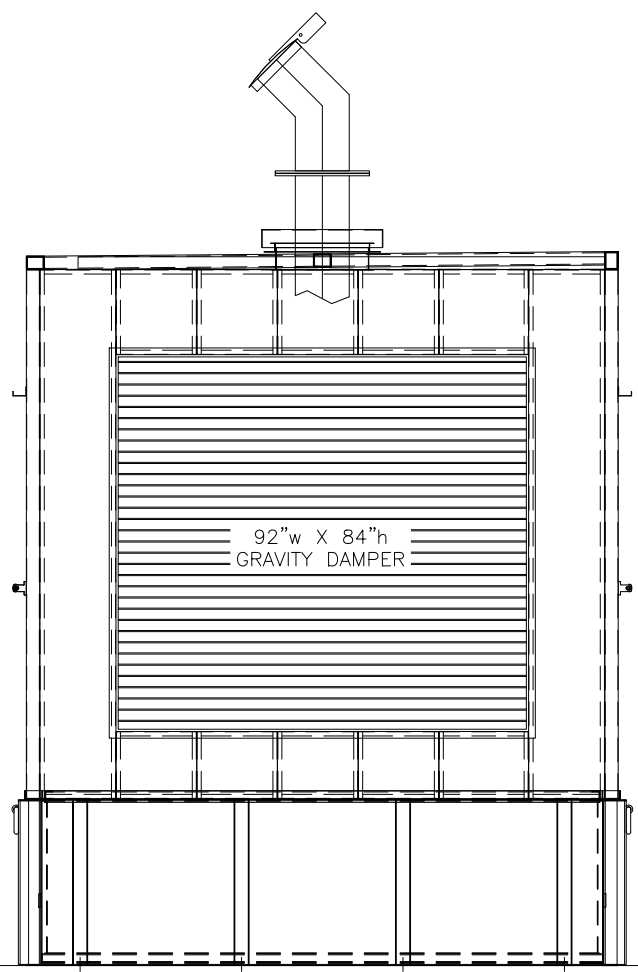

DISCHARGE END
W/O HOOD

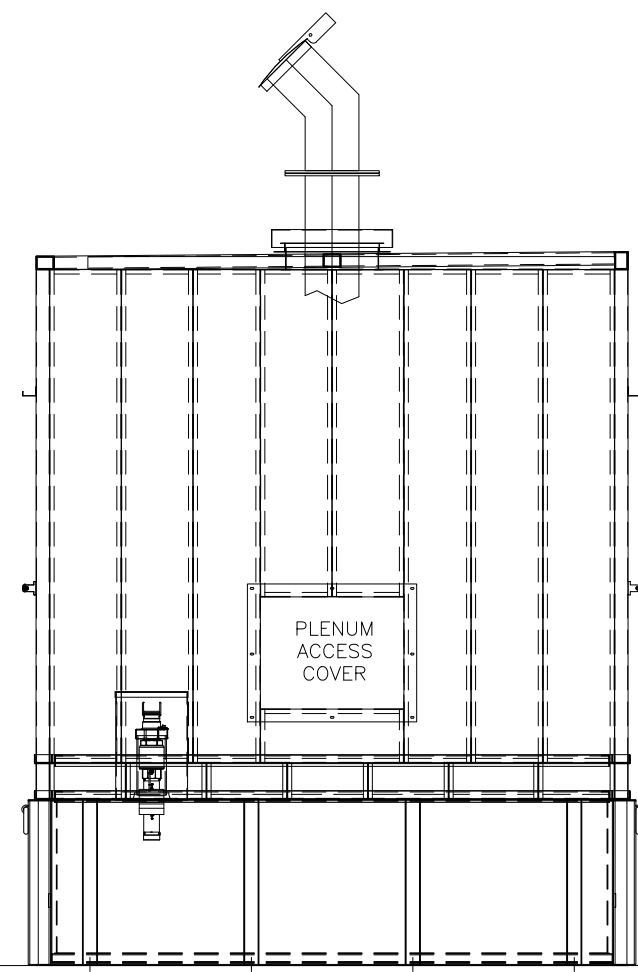

DISCHARGE END
W/ HOOD

City of Puyallup
Development & Permitting Services
ISSUED PERMIT

Building	Planning
Engineering	Public Works
Fire	Traffic

REVISIONS

REV.	DESCRIPTION:	DATE:	BY:	REV:	DESCRIPTION:	DATE:	BY:
1	ADDED DOCKING STATION, INCREASED LENGTH TO 48" WIDE X 50.5" DEEP X 91" TALL. ADDED STAIR, PAD LAYOUT DETAIL.	8/21/24	JRP	5	INCREASED THE SIZE OF THE DOCKING STATION TO 48" WIDE X 50.5" DEEP X 91" TALL.	9/6/24	JRP
3	MIRRORED DOCKING STATION, TRANSFORMER, LOAD PANEL, AND DISCONNECT SWITCH TO OPPOSITE SIDES, MOVED STUB UP UNDER INCREASED STUB UP SIZE. ADDED REMOVABLE STUB UP ACCESS PANEL. INCREASED HEIGHT OF TANK 1" FOR PROPER GALLONAGE.	9/5/24	JRP	6	ADDED FUEL PUSHER, UPDATED ELECTRICAL DIAGRAM	1/25/21	JRP
4		9/6/24	JRP				

CUSTOMER:
CERIO

PROJECT:
CENTERIS SEATTLE WA

DRAWN BY: JRP
DATE: 8/02/24
REVIEWED BY: JD/EJ
SCALE: NTS

SEE COVER PAGE OF SUBMITTAL FOR ESTIMATED WEIGHTS AND DIMENSIONS

PROJECT #: 20240161

COMPONENT CAD DRAWINGS

1287

TITLE: ELEVATIONS

SHEET: 5 OF 11

COASTLINE
POWER SOLUTIONS

1965 BENNETT DRIVE, DELAND, FL 32724
PHONE: 386-469-0070
WEBSITE: WWW.COASTLINEPOWERSOLUTIONS.COM

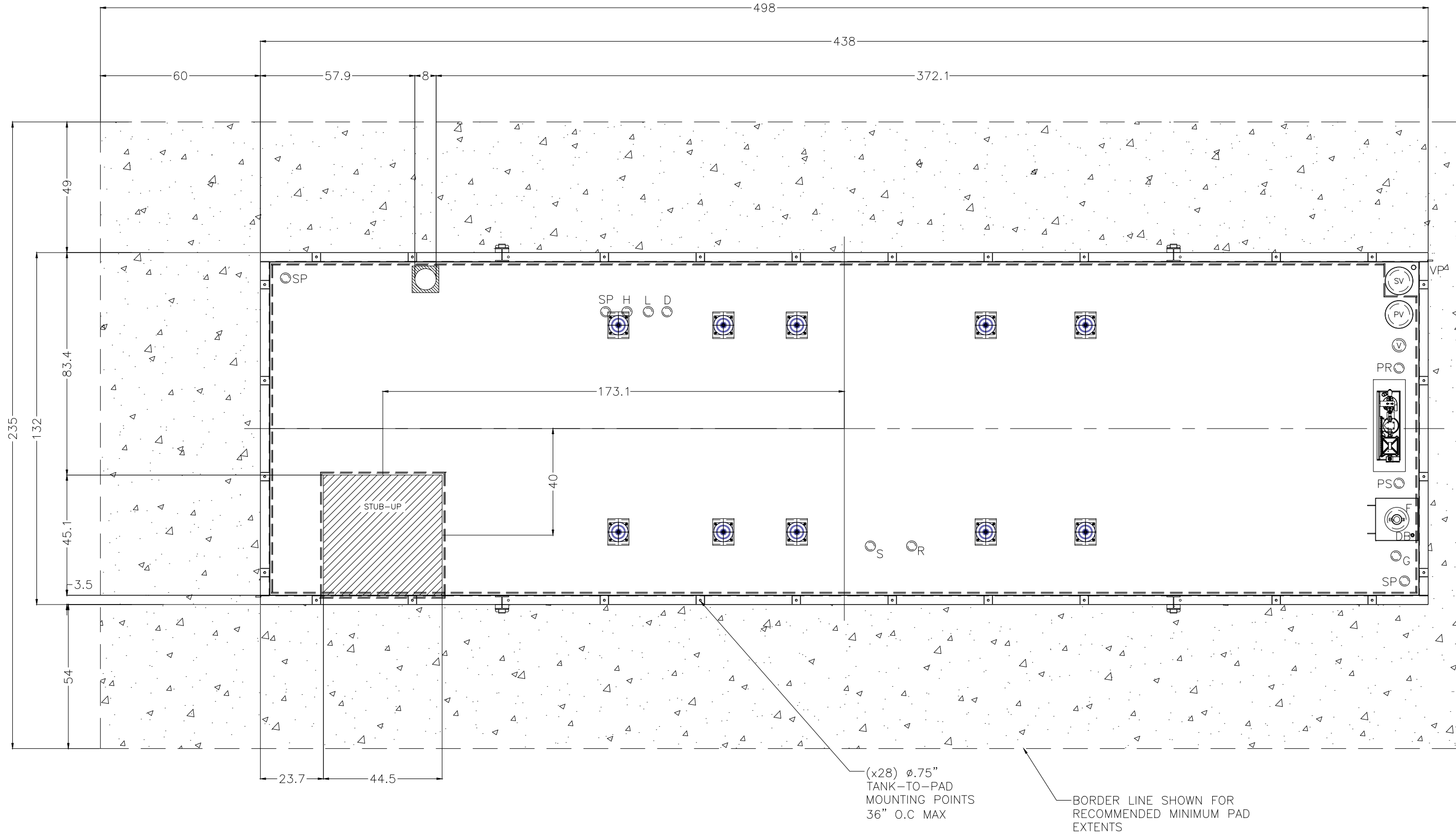

SUGGESTED
PAD LAYOUT

City of Puyallup
Development & Permitting Services
ISSUED PERMIT

Building	Planning
Engineering	Public Works
Fire	Traffic

(x28) ϕ .75"
TANK-TO-PAD
MOUNTING POINTS
36" O.C. MAX

BORDER LINE SHOWN FOR
RECOMMENDED MINIMUM PAD
EXTENTS

REV.	DESCRIPTION:	DATE:	BY:
1	ADDED DOCKING STATION, INCREASED LENGTH OF TANK, INCREASED STUB UP SIZE, ADDED STUB UP ACCESS PANEL, INCREASED HEIGHT OF TANK 1" FOR PROPER GALLOUSE	8/21/24	JRP
2	INCREASED THE SIZE OF THE DOCKING STATION TO 48 WIDE X 50.5 DEEP X 91 TALL	9/6/24	JRP
3	MIRRORED DOCKING STATION, TRANSFORMER LOAD PANEL, AND DISCONNECT SWITCH TO OPPOSITE SIDES, MOVED STUB UP UNDER INCREASED STUB UP SIZE, ADDED REMOVABLE STUB UP ACCESS PANEL, INCREASED HEIGHT OF TANK 1" FOR PROPER GALLOUSE	9/5/24	JRP
4	ADDED FUEL PUSHER, UPDATED ELECTRICAL DIAGRAM	9/6/24	JRP

CUSTOMER:		CENTERIS SEATTLE WA	
PROJECT:		CENTERIS SEATTLE WA	
DRAWN BY:	DATE:	REVIEWED BY:	SCALE:
JRP	8/02/24	JD/EJ	NTS

SEE COVER PAGE OF SUBMITTAL FOR ESTIMATED WEIGHTS AND DIMENSIONS

PROJECT #:	20240161
COMPONENT CAD DRAWINGS	---
1287	---
TITLE: PAD LAYOUT	---
SHEET:	6 OF 11

COASTLINE
POWER SOLUTIONS

1965 BENNETT DRIVE, DELAND, FL 32724
PHONE: 386-469-0070
WEBSITE: WWW.COASTLINEPOWERSOLUTIONS.COM



City of Puyallup
Development & Permitting Services
ISSUED PERMIT

Building	Planning
Engineering	Public Works
Fire	Traffic

REVISIONS

REV.	DESCRIPTION:	DATE:	BY:
1	ADDED DOCKING STATION, INCREASED LENGTH OF STUB-UP, ADDED STAIR, PAD LAYOUT DETAIL	8/21/24	JRP
2	INCREASED THE SIZE OF THE DOCKING STATION TO 48 WIDE X 50.5 DEEP X 91 TALL	9/6/24	JRP
3	MIRRORED DOCKING STATION, TRANSFORMER, LOAD PANEL, AND DISCONNECT SWITCH TO OPPOSITE SIDES, MOVED STUB UP UNDER	9/5/24	JRP
4	INCREASED STUB UP SIZE, ADDED REMOVABLE STUB UP ACCESS PANEL, INCREASED HEIGHT OF TANK 1" FOR PROPER GALLONAGE	9/6/24	JRP
6	ADDED FUEL POLISHER, UPDATED ELECTRICAL DIAGRAM	1/25/21	JRP

CUSTOMER: CERIO
PROJECT: CENTERIS SEATTLE WA

DRAWN BY: JRP	DATE: 8/02/24	REVIEWED BY: JD/EJ	SCALE: NTS
---------------	---------------	--------------------	------------

SEE COVER PAGE OF SUBMITTAL FOR ESTIMATED WEIGHTS AND DIMENSIONS

PROJECT #: 20240161
COMPONENT CAD DRAWINGS
1287

TITLE: PAD LAYOUT
SHEET: 6 OF 11

COASTLINE
POWER SOLUTIONS

1965 BENNETT DRIVE, DELAND, FL 32724
PHONE: 386-469-0070
WEBSITE: WWW.COASTLINEPOWERSOLUTIONS.COM

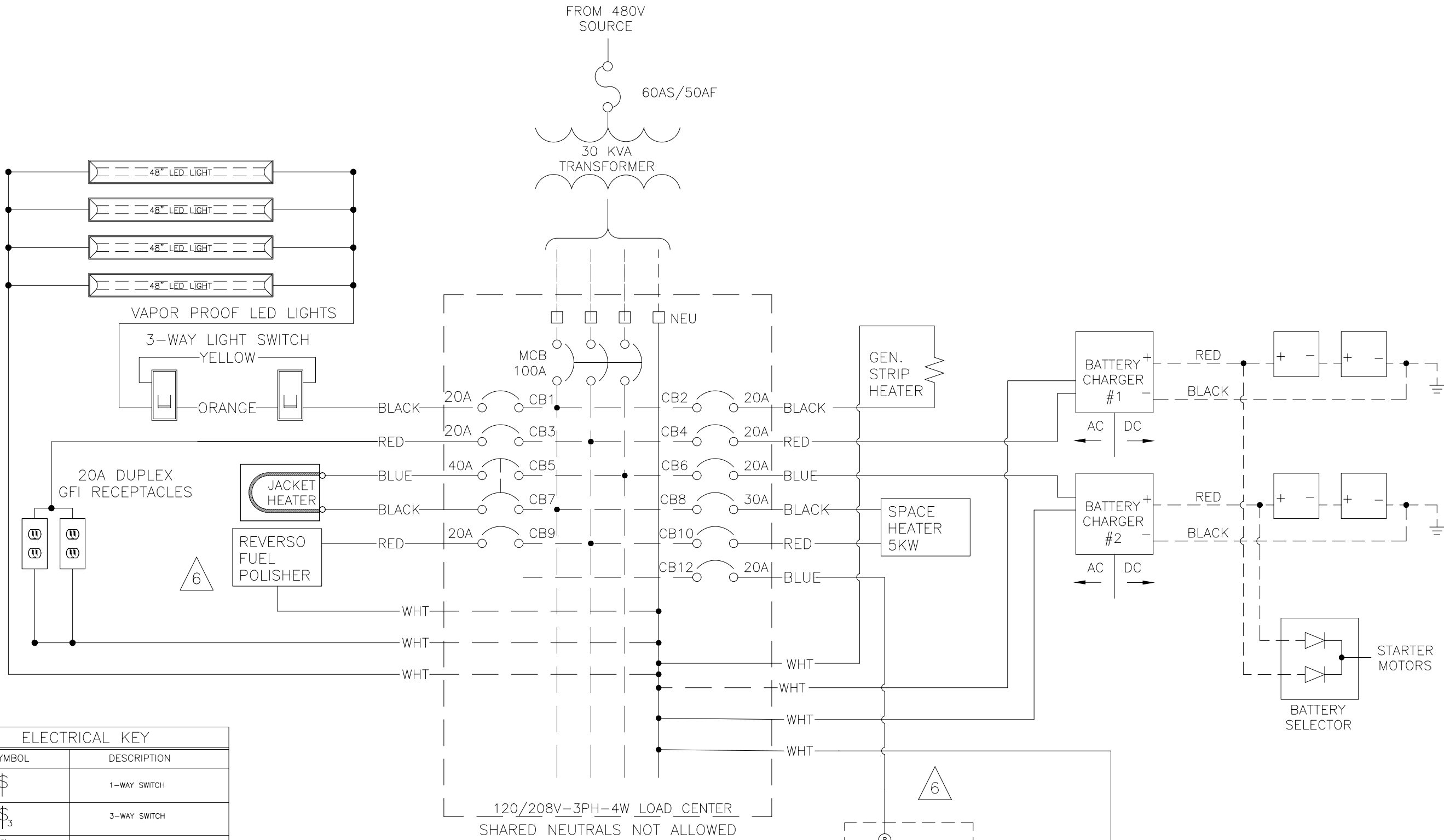

ELECTRICAL KEY	
SYMBOL	DESCRIPTION
\$	1-WAY SWITCH
\$ ₃	3-WAY SWITCH
GFCI	20A 125V DUPLEX GFCI RECEPTACLE
T ₆₀	60MIN TIMER
48" LED LIGHT	48" LED VAPORPROOF LIGHT FIXTURE
D.C. VAPORPROOF LIGHT FIXTURE	D.C. VAPORPROOF LIGHT FIXTURE
DUEL HEAD EMERGENCY LIGHT FIXTURE	DUEL HEAD EMERGENCY LIGHT FIXTURE
EXIT	EXIT LIGHT
BREAK GLASS TYPE EMERGENCY STOP	BREAK GLASS TYPE EMERGENCY STOP

*NOTE: THIS IS A STANDARD LEGEND, SOME SYMBOLS MAY NOT APPLY

THIS TO BE INSTALLED BY THE CITY OF PUYALLUP

Building	Planning
Engineering	Public Works
Fire	Traffic

REV.	DESCRIPTION	DATE	BY
1	ADDED DOCKING STATION, INCREASED LENGTH OF TANK, INCREASED BASEFRAME, ADDED STAIR, PAD LAYOUT DETAIL	8/21/24	JRP
2	ADDED DOCKING STATION, INCREASED LENGTH OF TANK, INCREASED BASEFRAME, ADDED STAIR, PAD LAYOUT DETAIL	8/21/24	JRP
3	MIRRORED DOCKING STATION, TRANSFORMER LOAD PANEL, AND DISCONNECT SWITCH TO OPPOSITE SIDES, MOVED STUB UP UNDER INCREASED STUB UP SIZE, ADDED REMOVABLE STUB UP ACCESS PANEL, INCREASED HEIGHT OF TANK 1" FOR PROPER GALLONAGE	9/5/24	JRP
4	ADDED DOCKING STATION, INCREASED LENGTH OF TANK, INCREASED BASEFRAME, ADDED STAIR, PAD LAYOUT DETAIL	9/6/24	JRP
5	INCREASED THE SIZE OF THE DOCKING STATION TO 48 WIDE X 50.5 DEEP X 91 TALL	9/6/24	JRP
6	ADDED FUEL POLISHER, UPDATED ELECTRICAL DIAGRAM	1/25/21	JRP

CUSTOMER:	CERIO
PROJECT:	CENTERIS SEATTLE WA
DRAWN BY:	JRP
DATE:	8/02/24
REVIEWED BY:	JD/EJ
SCALE:	NTS

SEE COVER PAGE OF SUBMITTAL FOR ESTIMATED WEIGHTS AND DIMENSIONS

PROJECT #:	20240161
COMPONENT CAD DRAWINGS	---
1287	---
TITLE: ELECTRICAL DIAGRAM	---
SHEET:	8 OF 11

COASTLINE POWER SOLUTIONS

1965 BENNETT DRIVE, DELAND, FL 32724
 PHONE: 386-469-0070
 WEBSITE: WWW.COASTLINEPOWERSOLUTIONS.COM

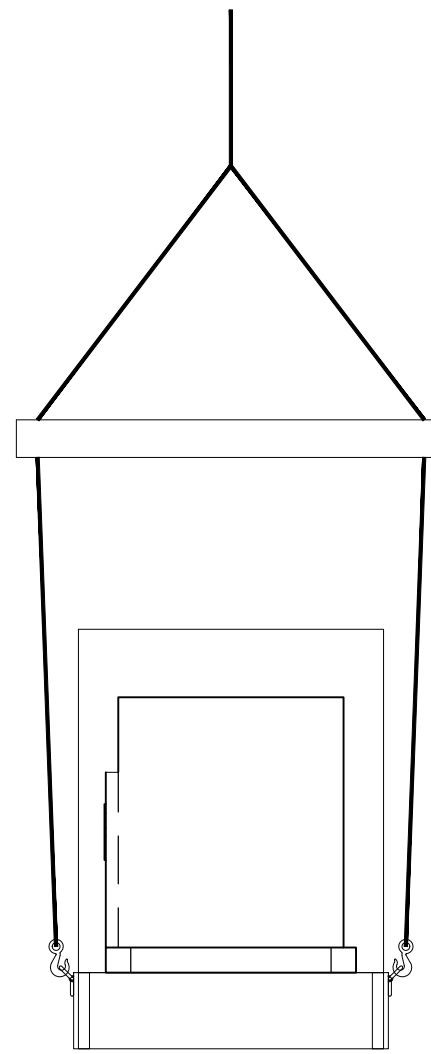
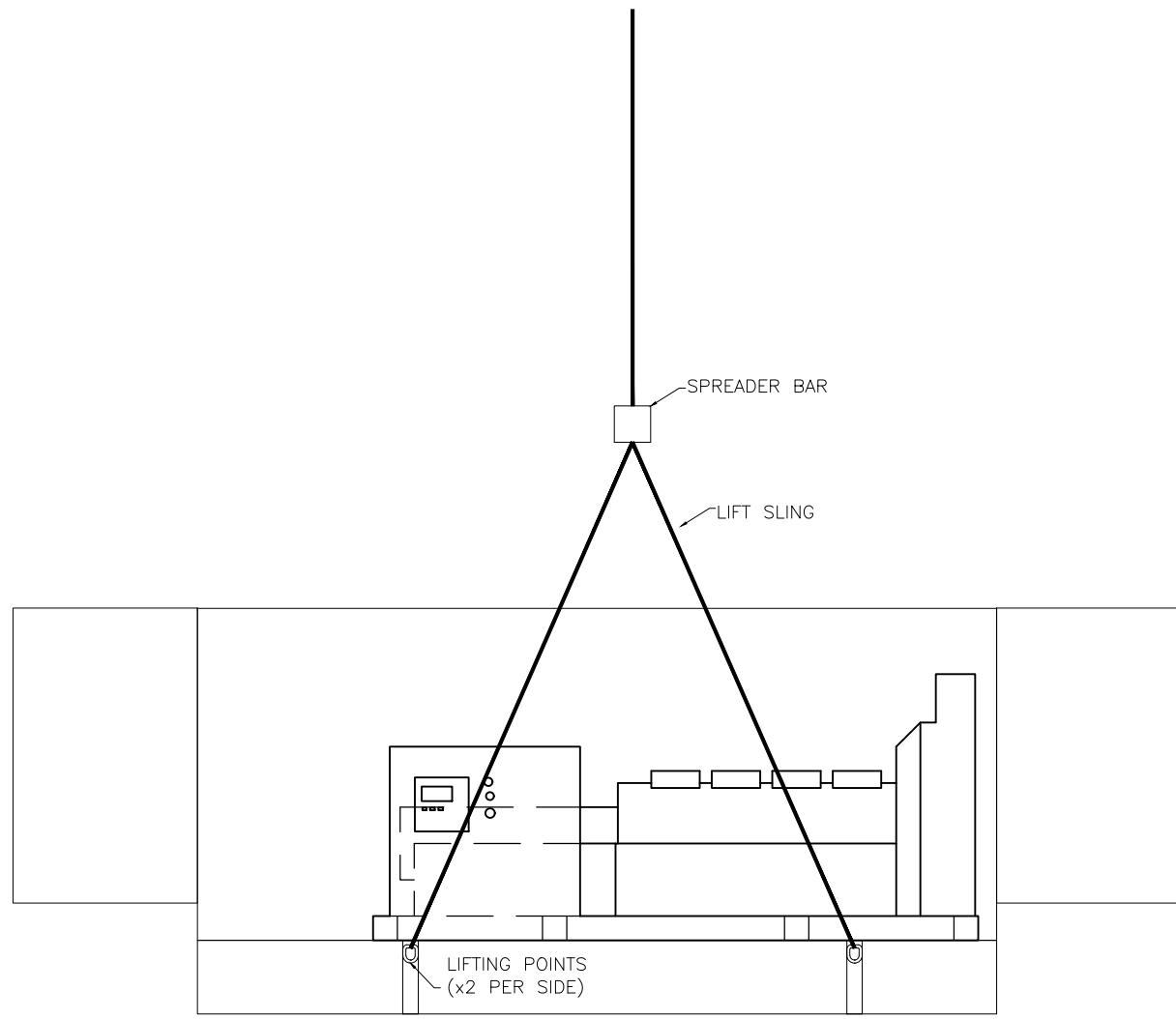

NOTE:
RIGGING IS SHOWN FOR
ILLUSTRATION PURPOSES ONLY.
UNIT DESIGN MAY VARY. FINAL
RIGGING TO BE DONE BY A
PROFESSIONAL, LICENSED AND
INSURED RIGGING COMPANY.

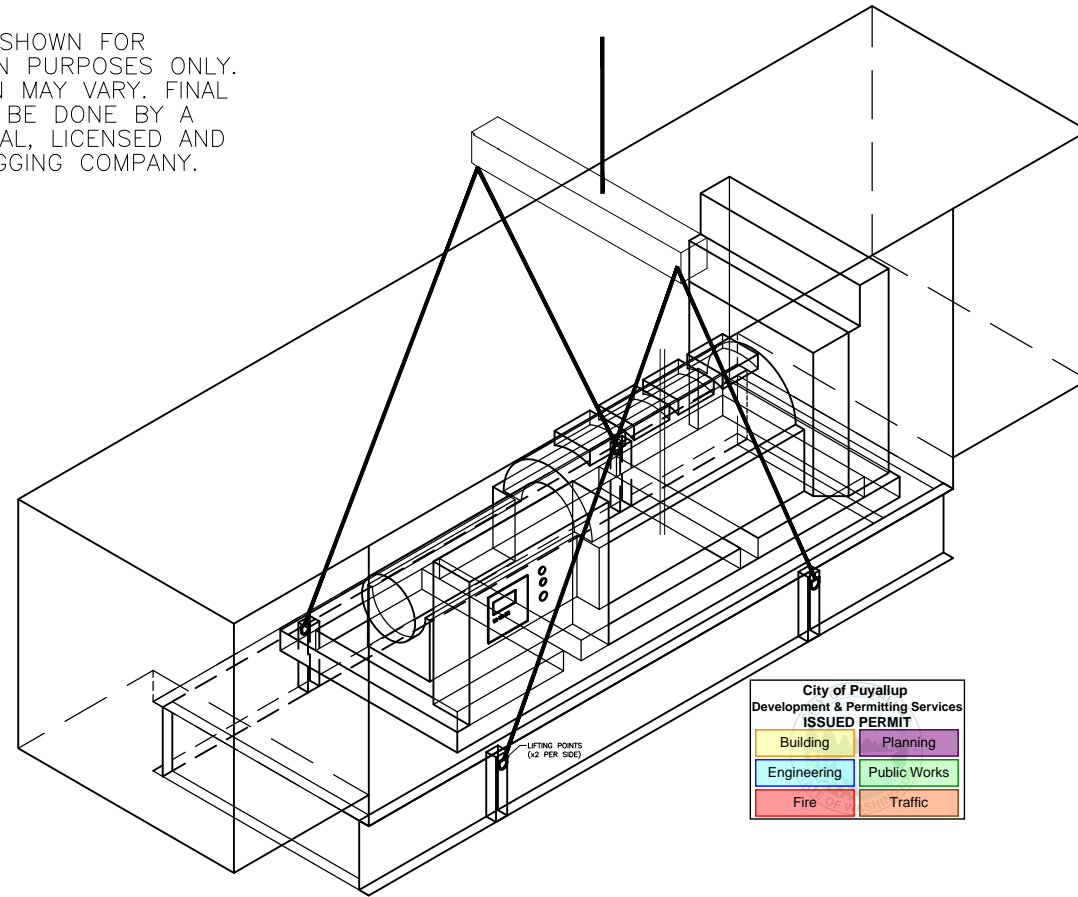

City of Puyallup
Development & Permitting Services
ISSUED PERMIT

Building	Planning
Engineering	Public Works
Fire	Traffic

SINGLE UNIT LIFTING

REV.	DESCRIPTION:	DATE:	BY:	REV:	DESCRIPTION:	DATE:	BY:
1	ADDED DOCKING STATION, INCREASED LENGTH OF TRANSFORMER TANK, INCREASED BASEFRAME, ADDED STAIR, PAD LAYOUT DETAIL	8/21/24	JRP	5	INCREASED THE SIZE OF THE DOCKING STATION TO 48 WIDE X 50.5 DEEP X 91 TALL	9/6/24	JRP
3	MIRRORED DOCKING STATION, TRANSFORMER, LOAD PANEL, AND DISCONNECT SWITCH TO OPPOSITE SIDES, MOVED STUB UP UNDER INCREASED STUB UP SIZE, ADDED REMOVABLE STUB UP ACCESS PANEL, INCREASED HEIGHT OF TANK 1" FOR PROPER GALLONAGE	9/5/24	JRP	6	ADDED FUEL PUSHER, UPDATED ELECTRICAL DIAGRAM	1/25/21	JRP
4		9/6/24	JRP				

CUSTOMER:		CENTERIS SEATTLE WA	
GCRIO		WA	
PROJECT:		CENTERIS SEATTLE WA	
DRAWN BY:	DATE:	REVIEWED BY:	SCALE:
JRP	8/02/24	JD/EJ	NTS

SEE COVER PAGE OF SUBMITTAL FOR ESTIMATED WEIGHTS AND DIMENSIONS

PROJECT #:	20240161
COMPONENT CAD DRAWINGS	---
1287	---
TITLE: TYP. LIFTING DIAGRAM	
SHEET: 9 OF 11	

COASTLINE
POWER SOLUTIONS

1965 BENNETT DRIVE, DELAND, FL 32724
PHONE: 386-469-0070
WEBSITE: WWW.COASTLINEPOWERSOLUTIONS.COM

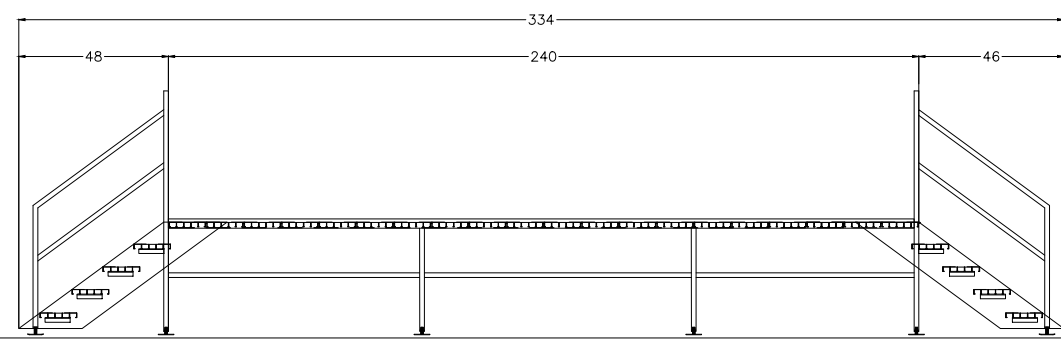
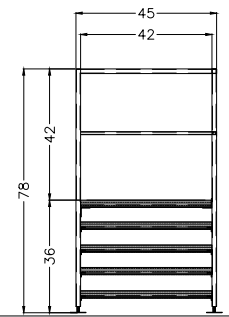
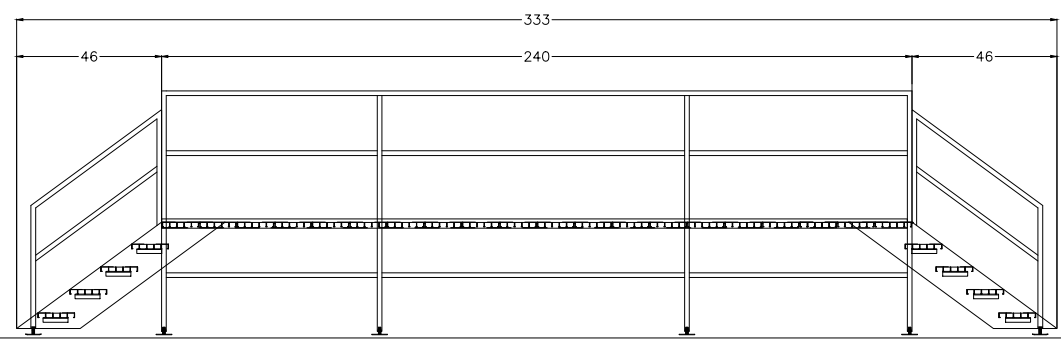
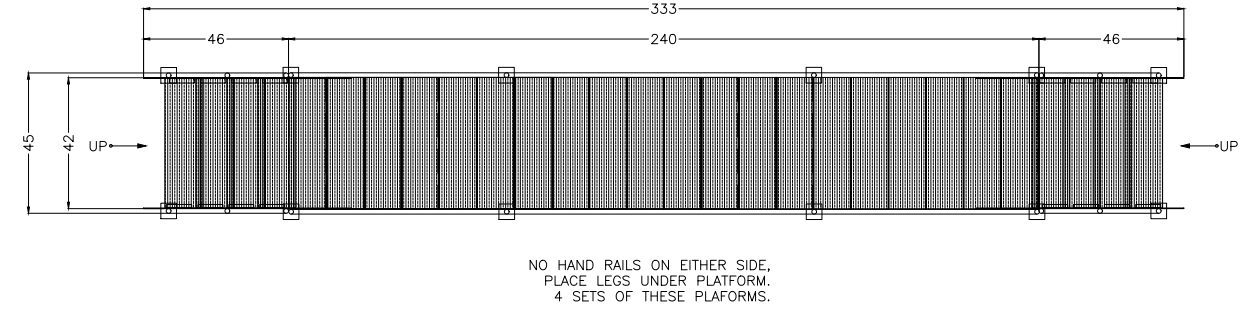
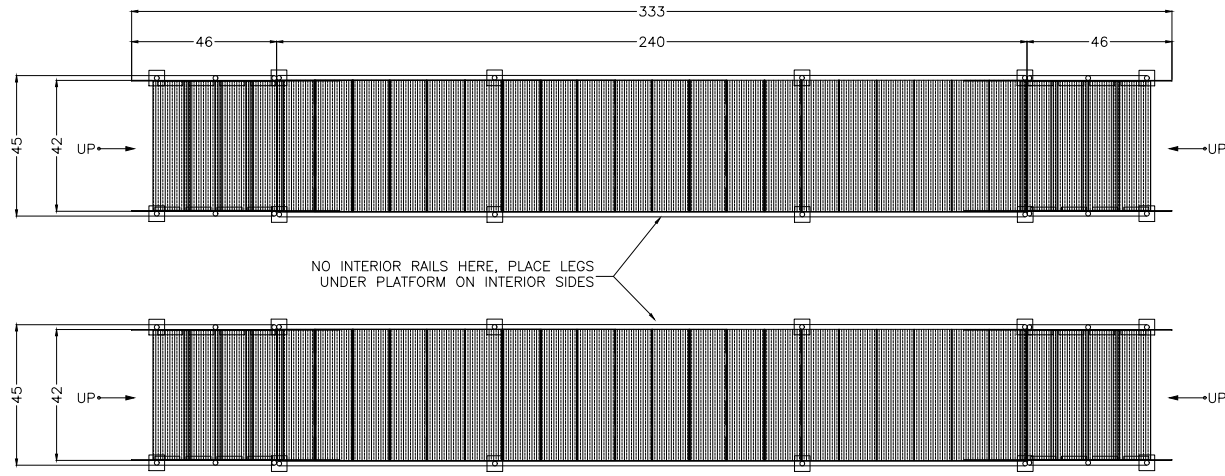

City of Puyallup
Development & Permitting Services
ISSUED PERMIT

Building	Planning
Engineering	Public Works
Fire	Traffic

REVISIONS

REV.	DESCRIPTION:	DATE:	BY:	REV:	DESCRIPTION:	DATE:	BY:
1	ADDED DOCKING STATION, INCREASED LENGTH OF DOCKING STATION TO 48 WIDE X 50.5 DEEP X 91 TALL. ADDED STAIR, PAD LAYOUT DETAIL.	8/21/24	JRP	5	INCREASED THE SIZE OF THE DOCKING STATION TO 48 WIDE X 50.5 DEEP X 91 TALL.	9/6/24	JRP
3	MIRRORED DOCKING STATION, TRANSFORMER, LOAD PANEL, AND DISCONNECT SWITCH TO OPPOSITE SIDES, MOVED STUB UP UNDER INCREASED STUB UP SIZE. ADDED REMOVABLE STUB UP ACCESS PANEL, INCREASED HEIGHT OF TANK 1" FOR PROPER GALLONAGE.	9/5/24	JRP	6	ADDED FUEL PUSHER, UPDATED ELECTRICAL DIAGRAM	1/25/21	JRP
4		9/6/24	JRP				

CUSTOMER: CENTERIS SEATTLE WA
GEO: CENTERIS SEATTLE WA
PROJECT: CENTERIS SEATTLE WA
DRAWN BY: JRP
DATE: 8/02/24
REVIEWED BY: JD/EJ
SCALE: NTS

SEE COVER PAGE OF SUBMITTAL FOR ESTIMATED WEIGHTS AND DIMENSIONS

PROJECT #: 20240161
COMPONENT CAD DRAWINGS
1287
TITLE: STAIRS & PLATFORMS
SHEET: 10 OF 11

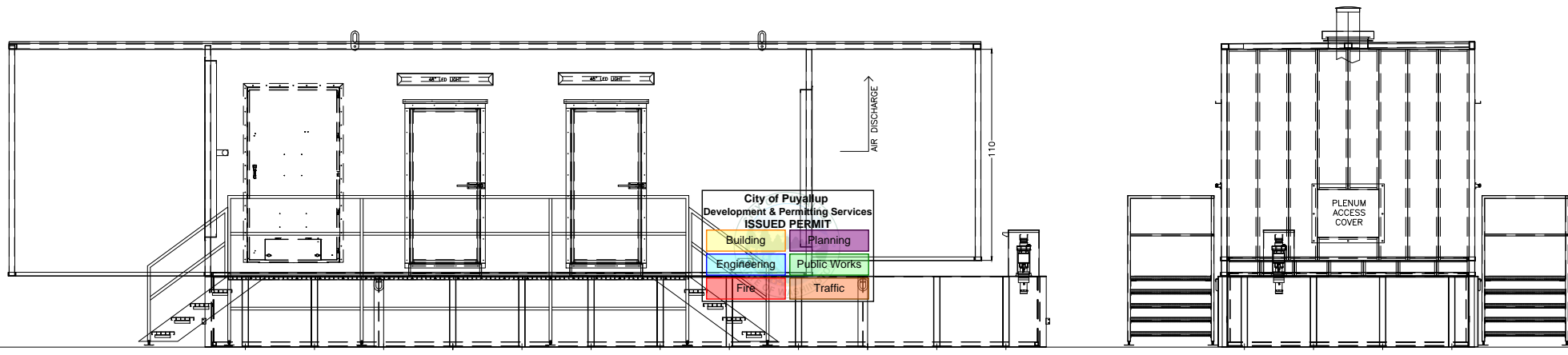

PLAN VIEW



City of Puget Sound
Development & Permitting Services
ISSUED PERMIT

Building	Planning
Engineering	Public Works
Fire	Traffic

PROJECT #: 20240161
 COMPONENT CAD DRAWINGS
 1287
 TITLE: STAIRS & PLATFORMS
 SHEET: 11 OF 11

CUSTOMER:
 CERIO
 PROJECT:
 CENTERIS SEATTLE WA
 DRAWN BY: JRP
 DATE: 8/02/24
 REVIEWED BY: JD/EJ
 SCALE: NTS

REV.	DESCRIPTION:	DATE:	BY:	REV.	DESCRIPTION:	DATE:	BY:
1	ADDED DOCKING STATION, INCREASED LENGTH OF STAIRS TO 48" WIDE X 50.5" DEEP X 91" HIGH. ADDED STAIR PAD LAYOUT DETAIL.	8/21/24	JRP	5	INCREASED THE SIZE OF THE DOCKING STATION TO 48" WIDE X 50.5" DEEP X 91" HIGH.	9/6/24	JRP
3	MIRRORED DOCKING STATION, TRANSFORMER LOAD PANEL, AND DISCONNECT SWITCH TO OPPOSITE SIDES. MOVED STUB UP UNDER INCREASED STAIR UP SIZE. ADDED REMOVABLE STUB UP ACCESS PANEL. INCREASED HEIGHT OF TANK 1" FOR PROPER GALLONAGE.	9/5/24	JRP	6	ADDED FUEL PUSHER, UPDATED ELECTRICAL DIAGRAM	1/25/21	JRP
4		9/6/24	JRP				

SEE COVER PAGE OF SUBMITTAL FOR ESTIMATED WEIGHTS AND DIMENSIONS

Commercial Automatic Fuel Polishing 600 GPH

Automatic Fuel Polishing (AFP) removes water, bacterial growth and other particulate from diesel that are detrimental to fuel systems and thereby resolving many issues related to degraded fuel.

Basic Features

- Primary filtration - Separ Filter with vacuum gauge
- Secondary filtration - 2 micron
- Available in 120V and 220V
- Aluminum cover and base with spill containment
- Mountable base
- Water level alarm and shutoff
- Vacuum alarm and shutoff
- Spill alarm and shutoff

Optional Features

- Enclosure
- Enclosure with stand



Wall Mount



Enclosure



Enclosure with Stand

Technical Specifications

Flow Rate	600 GPH / 2271 LPH	
Inlet / Outlet	1" Male JIC	
Voltage	120V or 220V	
Amp. Draw	3.4A, 110V / 60Hz 3.2A, 220V / 50Hz	
Circuit Breaker	10A, 110V / 60Hz 10A, 220V / 50Hz	
Lift	13 ft / 4 m with foot valve above liquid level	
Pump Type	Vane Pump	
Primary Filtration	Standard 30 micron	
Secondary Filtration	2 micron	
Wall Mount Dimensions	A	28.4" / 721 mm
	B	28.2" / 716 mm
	C	10.9" / 276 mm
Enclosure Dimensions	A	34.5" / 876 mm
	B	30" / 762 mm
	C	12" / 305 mm
Enclosure with Stand Dimensions	A	34.5" / 876 mm
	B	59.75" / 1518 mm
	C	12" / 305 mm

Replacement Elements

04010	10 micron
04030	30 micron
04060S	60 micron, stainless steel
04-3382	2 micron spin on

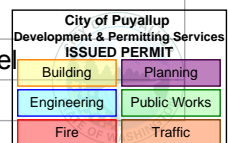

AFP-600

Submittal



Shown with optional enclosure and stand

Automatic Fuel Polishing System

- Digital or Touchscreen control
- Staged diesel fuel filtration system
- Shutdown and visual / audio alarms
- Optional enclosure and stand

Contact Us

Reverso Pumps LLC
4001 SW 47th Ave, Suite 201
Davie, FL 33314
Ph: (954) 522-0885
customerservice@reverso.com
www.reversopumps.com

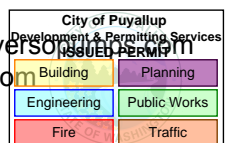
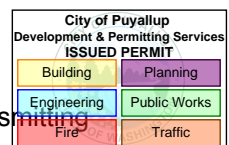

Table of Contents

Description.....	3
System Overview.....	4
5-Stage Primary Filtration.....	5
Dimensions: Wall Mount.....	6
Dimensions: Optional Enclosure	7
Dimensions: Optional Enclosure and Stand	8
Technical Specifications and Spare Parts	9
Electrical and Piping Installation.....	10
Tank Diagrams.....	11
MODBUS Configuration Table (Siemens Digital Control).....	12
MODBUS Configuration Table (Siemens Touchscreen Control)	13
Control Box Wiring.....	14
Emergency Stop (E-Stop).....	15
Control Panel with Digital Timer: Overview, Alarms, Reset	16
Digital Control	17
Touchscreen Control: Program Setup	18
Touchscreen Control: Alarm Status	19
Touchscreen Control: System Time Setup and System Log	20
Touchscreen Control: System Overview.....	21
Touchscreen Control: Maintenance	22
Primary Filter Maintenance.....	23
Spin-On Filter Replacement	24
Pump Data Sheet.....	25
Primary Filtration Data Sheet	26
Secondary Filtration Data Sheet.....	27
Troubleshooting and Warranty	28

The information herein is the property of Reverso Pumps LLC. Without written permission, any copying, transmitting to others, and other use except for which it is loaned is prohibited.



System Description

Reverso Automatic Fuel Polishing (AFP) System is designed for middle distillate fuels with flash points of 100°F and above. This includes #1,2 and 3 diesel fuel, home heating oil and bio-diesel up to B20, with no modifications required. The AFP single-tank system is designed specifically to maintain diesel fuel quality in storage tanks and standby generator sub-base tanks. This is accomplished by first removing all free water and particulate to 30 micron in the primary fuel water separator by Separ Filter, and further reducing particulate to as low as 2 micron through a secondary filter. This system is constructed with a 7-day programmable digital timer, with alarms for high vacuum and high water in the primary filter, and high pressure in the secondary filter. A drip pan high level float alarm is also included.

Control

The AFP system operates at 110 volt 60Hz (also available in 220V 50Hz). This system is equipped with an control for unattended operation and is UL508A listed. All system controls are housed in a NEMA 4 water-tight control box.

Digital control with 7-day programming provides flexibility in scheduling polishing operations. User can create a weekly schedule to automatically run the system.

The following monitoring systems are provided:

- Primary filter high vacuum
- Primary filter high water
- Secondary filter high pressure
- Drip tray high level

When equipped with an enclosure option, an electrical junction box is located on the exterior and houses the emergency stop button.

Primary Filtration

The AFP System is designed around the Separ Filter brand of diesel fuel water separators. This filter has been specifically designed to utilize hydrodynamic principles to remove free water and particulate from the flow of the fuel. By changing the direction of flow and the velocity of the fuel multiple times, and imparting centrifugal force, the heavier particulate and free water drop from suspension and fall to the bottom of the bowl. As these natural laws are put into effect on the fuel, it passes through 5 stages within the Separ Filter housing. For this reason, approximately 70+% of the contaminants are removed from the fuel prior to passing through the final stage filter element, bringing the particulate removal efficiency to 100% for particulate larger than the element rating (30 micron standard) and a high level of separation

for smaller particulate in test fluid using standard test methods. At the rated flow of 10 gallons per minute, the filter is 100% efficient at removing free water as certified by the RWTUV testing facility in Germany (copy available upon request).

The 5 stages of separation and filtration are:

Refer to Diag. 1

1. After entering the inlet(s), the 1st vane system spins the diesel fuel in a circular motion, generating centrifugal force.
2. In the bowl, fuel continues to spin – separating water and heavier particulates, through centrifugal force.
3. A 2nd vane system then forces the fuel to spin in a different direction – separating smaller water droplets and finer particulates.
4. A wider passage, just below the element, slows down fuel to allow more contaminants to settle into the bowl.
5. Finally, the element filters finer particulates out of the fuel before exiting through the outlet(s).

Secondary Filtration

Once fuel has been filtered, it passes through the pump and finally to a 2 micron filter (10 micron water block is available). It removes particulate contaminant such as dirt, dust and rust. The cellulose/microglass media offers higher efficiencies and longer filter life. Gaskets are pre-lubed. It is recognized by the Underwriters Laboratory (UL®) for use with service station pumps and dispensers.

Optional Features

Certain applications can benefit from optional features, which are additional to the standard AFP System. Contact your representative for details and pricing.

- Enclosure
- Stand for enclosure
- Flow meter
- Magnetic fuel conditioner
- Basket strainer
- Y-strainer
- Isolation valves
- Tank selector valves
- Hand primer
- Fuel primer FP-321
- Solenoid valves
- Multiple tank option
- Automatic water drain

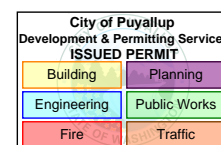

- 1 Base
- 2 Identification plate
- 3 Vacuum gauge
- 4 Primary filtration: SWK-2000/40MK
- 5 Inlet
- 6 Drain valve - *Push in and turn counter-clockwise to open*
- 7 Drip pan
- 8 Digital or touchscreen control
- 9 Power in
- 10 Hinged cover - *covers pump*
- 11 Outlet
- 12 Secondary filtration: 2 micron spin-on
- 13 Emergency stop button
- 14 Fan

Wall Mount System

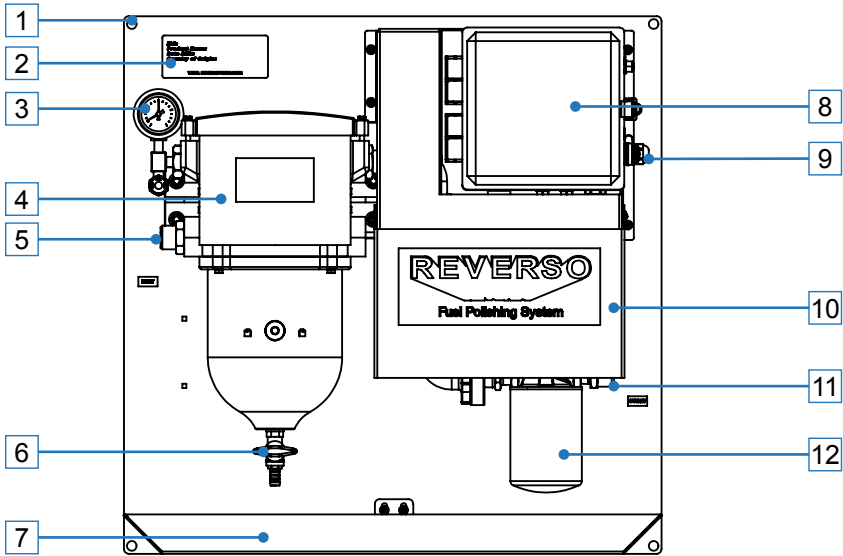

System With Optional Enclosure

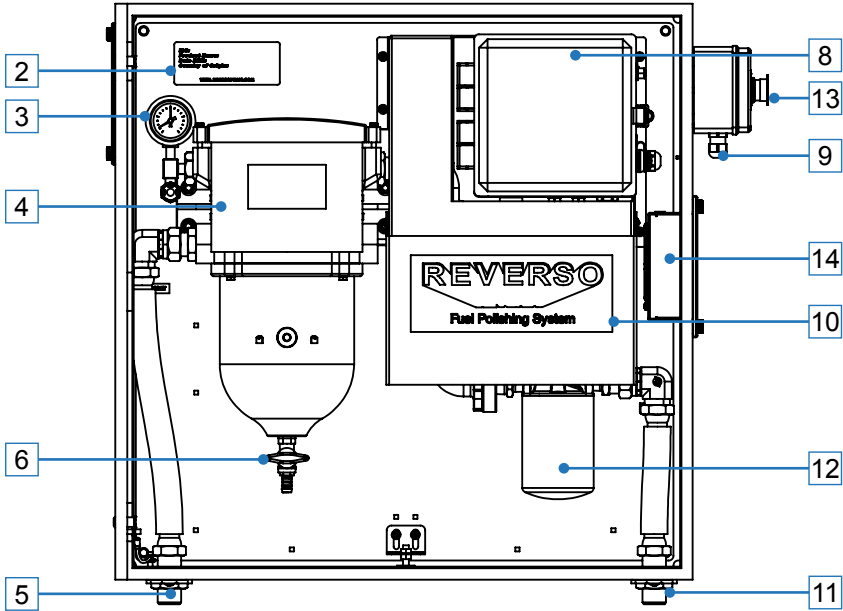

City of Puyallup
Development & Permitting Services
ISSUED PERMIT

Building	Planning
Engineering	Public Works
Fire	Traffic

1

After entering the inlet(s), the 1st vane system spins the diesel fuel in a circular motion, generating centrifugal force.

2

In the bowl, fuel continues to spin – separating water and heavier particulates, through centrifugal force.

3

A 2nd vane system then forces the fuel to spin in a different direction – separating smaller water droplets and finer particulates.

4

A wider passage, just below the element, slows down fuel to allow more contaminants to settle into the bowl.

5

Finally, the element filters finer particulates out of the fuel before exiting through the outlet(s).

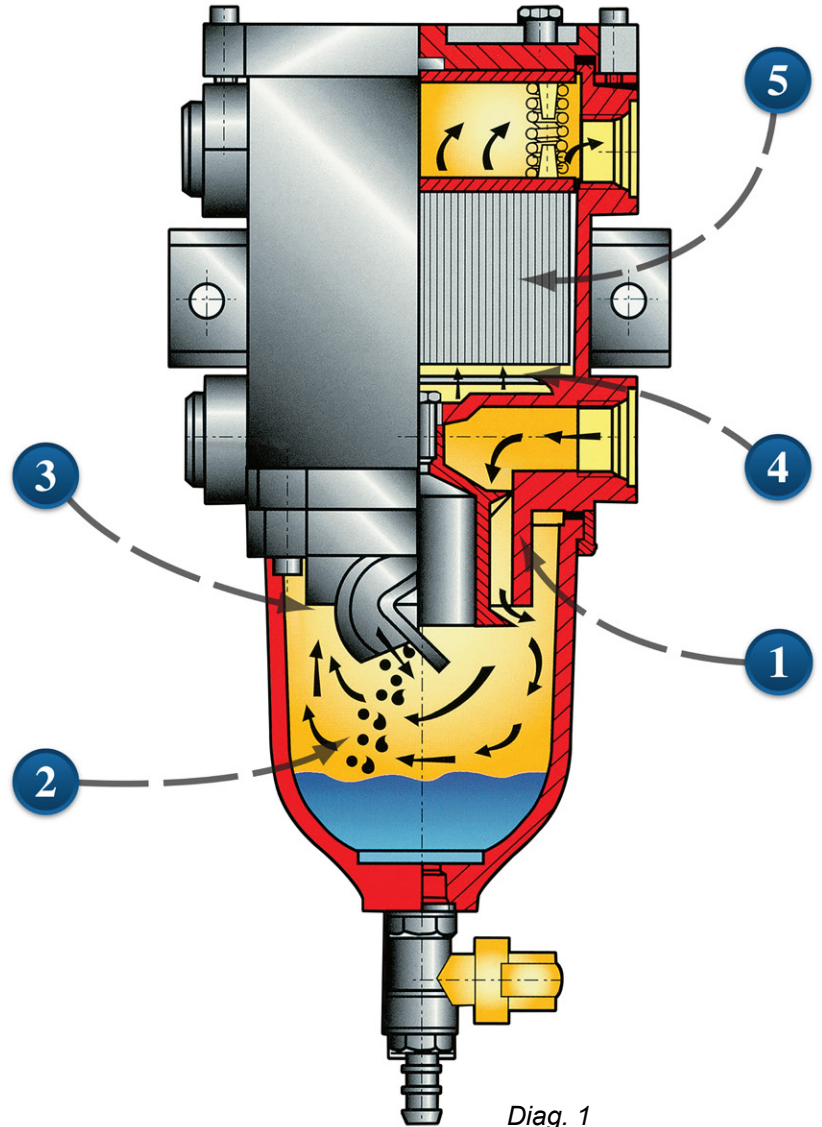

City of Puyallup Development & Permitting Services ISSUED PERMIT			
Building	Planning	Engineering	Public Works
Fire	Traffic		

Power In (9ft. Cable)
Digital Controller Box

Primary dimensions - inches
Secondary dimensions - centimeters

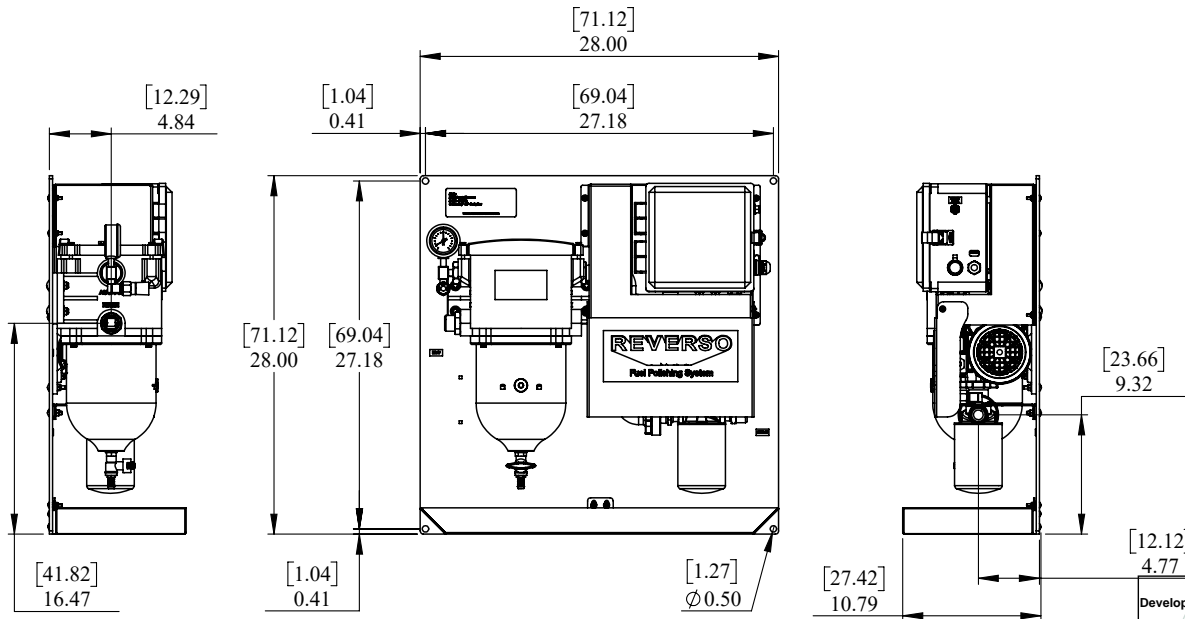
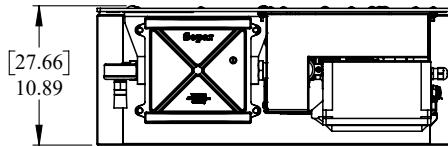
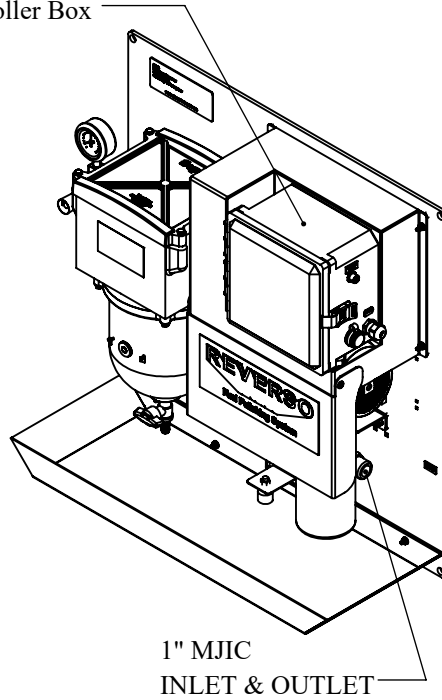

City of Puyallup
Development & Permitting Services
ISSUED PERMIT

Building	Planning
Engineering	Public Works
Fire	Traffic

Dimensions: Optional Enclosure

Primary dimensions - inches
Secondary dimensions - centimeters

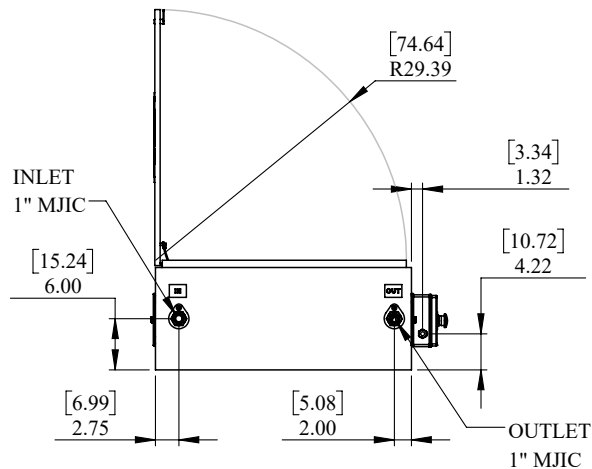
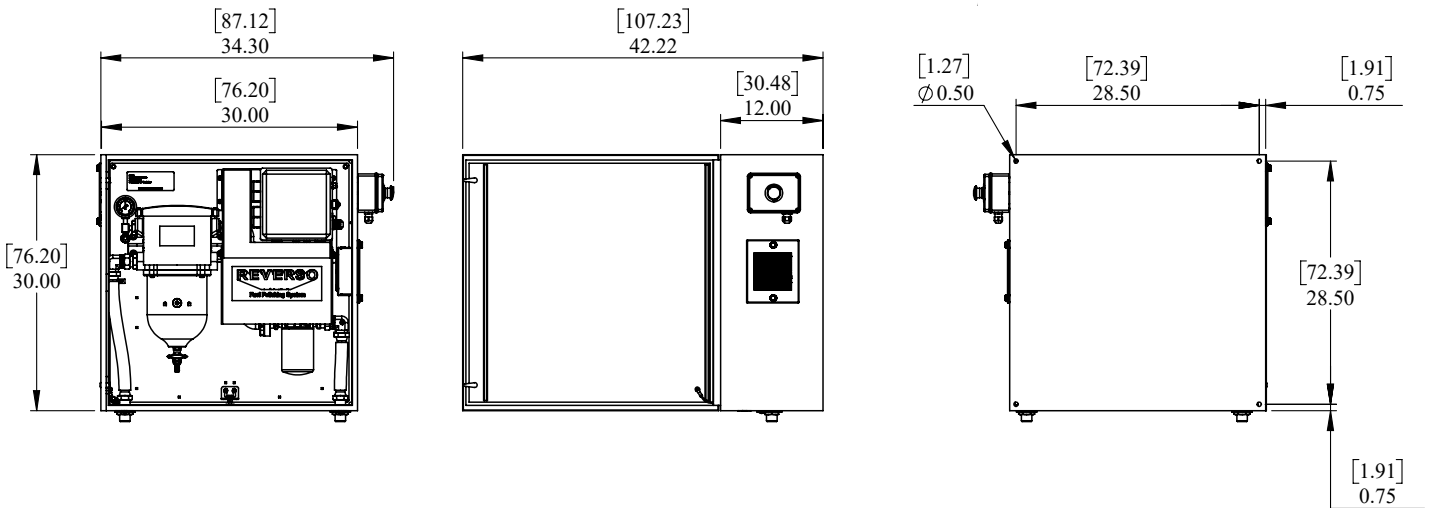
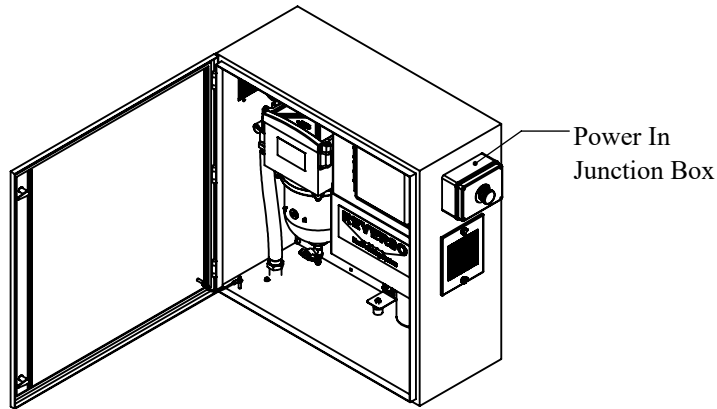

City of Puyallup Development & Permitting Services ISSUED PERMIT	
Building	Planning
Engineering	Public Works
Fire	Traffic

Dimensions: Optional Enclosure and Stand

Primary dimensions - inches
Secondary dimensions - centimeters

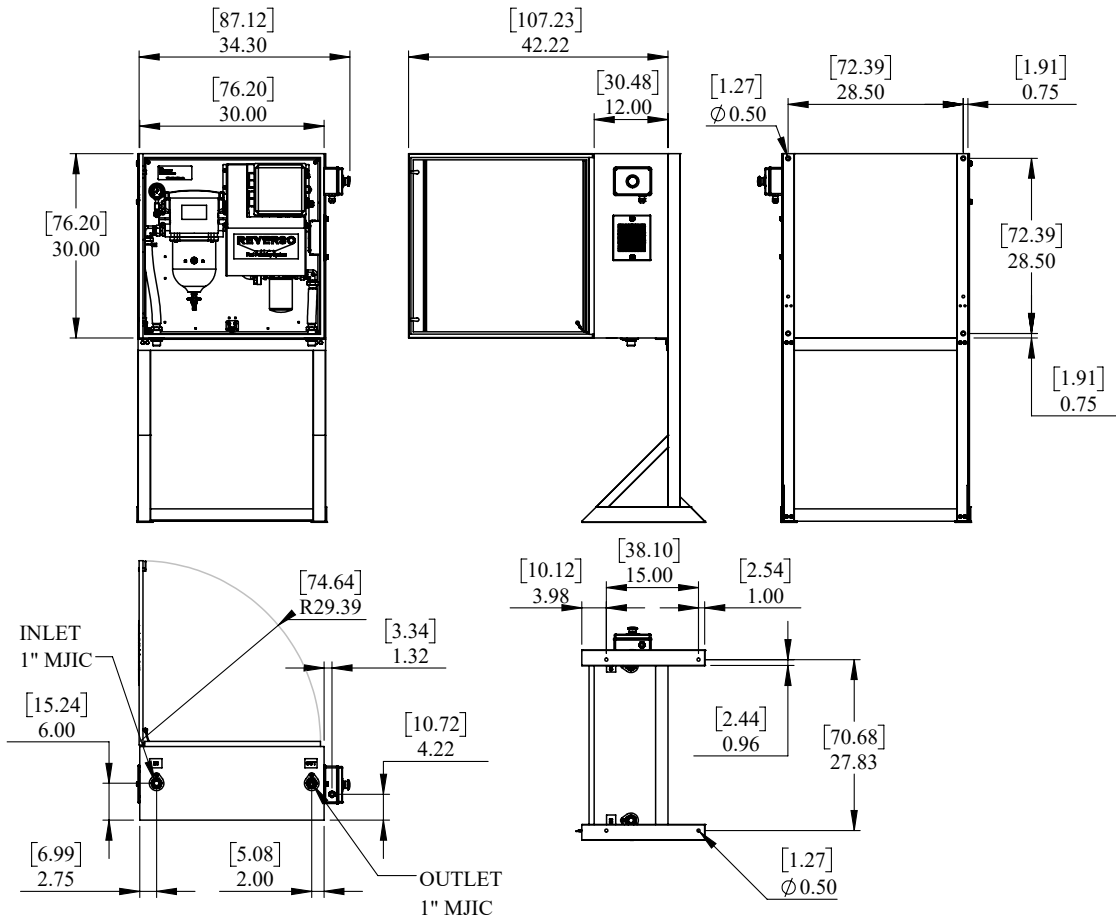
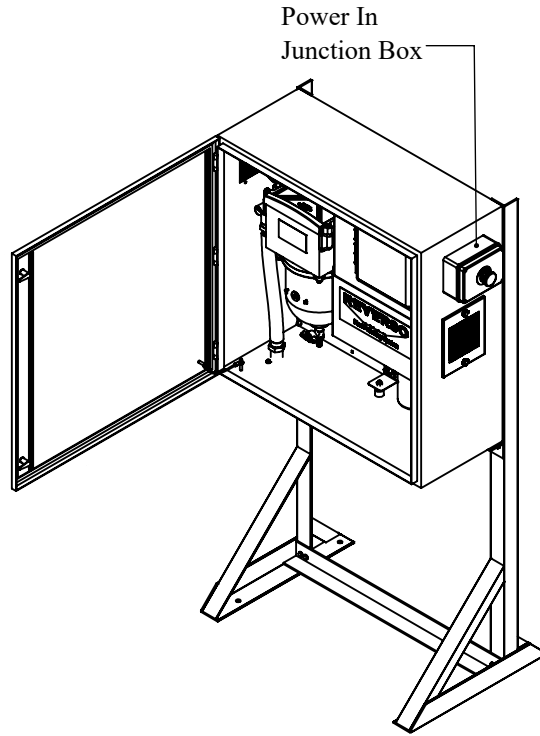

City of Puyallup Development & Permitting Services ISSUED PERMIT	
Building	Planning
Engineering	Public Works
Fire	Traffic

Technical Specifications

Nominal Flow Rate	System rated at 600 GPH (2271 LPH). Actual flow rate may vary due to conditions of installation.	
Voltage	110V AC 60Hz single phase	
Amperage Draw	3.4A / 110V	
Circuit Breaker	10A / 110V	
Pump Type	Vane	
Pump Relief Valve	Internal, non-adjustable and preset at 35 psi (2.4 bar)	
Pump Rating	TEFC for continuous duty operation	
Maximum Lift	13 ft (4m) with foot valve above liquid level	
Control	Digital or Touchscreen	
Inlet / Outlet	1" Male JIC	
Primary Filtration	Replacement element # 60-04030	
Primary Filter Torque Values	Bowl Retainer Ring	13 Nm (115 in-lbs)
	Lid	15 Nm (130 in-lbs)
	Bleed Screw	6 Nm (53 in-lbs)

Spare Parts

Part #	Description
60-04010	Separ 04010, 10 micron element
60-04030	Separ 04030, 30 micron element
60-04060	Separ 04060S, 60 micron element, stainless
66-30440	Separ lid gasket
66-30442	Separ bowl gasket
05-0839	Vacuum gauge
04-3382	Spin-on filter, 2 micron

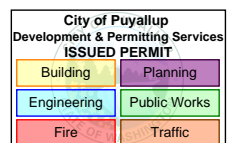

Primary Inspection

- Upon delivery inspect the AFP (Automated Fuel Polishing) system for any damage that may have occurred during shipment.
- Inspect the interior of the unit for mechanical or electrical damage.
- If the unit is damaged upon delivery, contact the shipping company immediately.

Mounting

- The AFP should be wall mounted on a hard, vertical surface capable of supporting the weight of the unit.
- A unit without an enclosure should be located under shelter, out of the weather if possible. The unit with the optional enclosure can be located in any location accessible to the operator.
- In all cases the unit should be located as close as possible to the tank being serviced. (see Max. Lift in Technical Specifications).
- When installing the unit below the level of the fuel on above ground fuel tanks, consideration should be made to the installation of an anti-siphon valve to prevent fuel spillage in the case of a leak in the piping system.

Electrical

- Installation of unit should only be performed by qualified installation personnel who have thoroughly read and understand the installation instructions covered in this manual.
- To avoid the risk of electric shock, make sure that the power supply is disconnected. Ensure that the power supply is at zero volts with a multimeter before making any electrical connections.
- To ensure operator safety the AFP must be connected to properly grounded power sources.
- Make sure that your unit and power supply are configured for the same voltage rating.
- Remote alarms are for external use.
- External control voltage must be supplied by customer.

Piping

Use quality approved fuel line materials with at least 1" inner diameter line. Smaller plumbing will place excessive load on the motor and shorten its life. A full port ball valve should be installed on the inlet and outlet ports of the AFP.

The pickup line(s) (suction) should originate from the lowest point of the tank and should be connected directly to the inlet. The distance from the bottom of the tank should be approximately half the distance of the inner diameter of the tube being used.

It should be below the suction of the engine or generator and preferably away from them.

For optimal performance, ensure that this line is free and nothing is restricting flow. It is recommended to install a foot valve to keep the system primed, especially if the system is located above the lowest possible fuel level in the tank.

If the AFP is mounted below tank top level, a priming tee should be installed on the highest point of the suction line to be able to easily prime the systems suction line.

The return line(s) (discharge) should be connected to the outlet and enter the tank as far as possible from the pick up tube and extending 2/3 down into the tank. For optimal performance, ensure that the outlet, discharge or return, line(s) are free and nothing is restricting their flow.

The suction line of the AFP must be independent and separate from the suction line of the engine. Do not integrate into engine fuel system.

When installing this unit, FLEXIBLE CONNECTIONS MUST BE USED TO REDUCE STRESS on the plumbing and prevent damage to the unit.

The system must be primed before operation.

Warning

- The system has been developed to be used with diesel fuel only. **DO NOT USE WITH GASOLINE.**
- The system is designed to meet environmental standards for safe operation (NOT for use with fluids that have a flash point below 100°F (38°C) (e. g. gasoline, alcohol).
- Failure to prime the system before use could cause serious damage to the pump/motor.

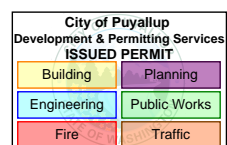

Hoses, piping, solenoid valves and foot valves shown in the diagrams below are not provided with the system and must be provided by the user/contractor, unless agreed upon otherwise.

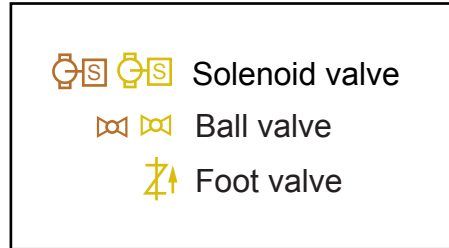

Single Tank Diagram

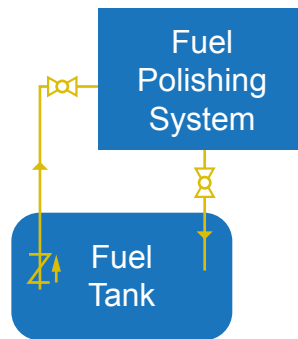

Multiple Tank Diagram

Available upon request.

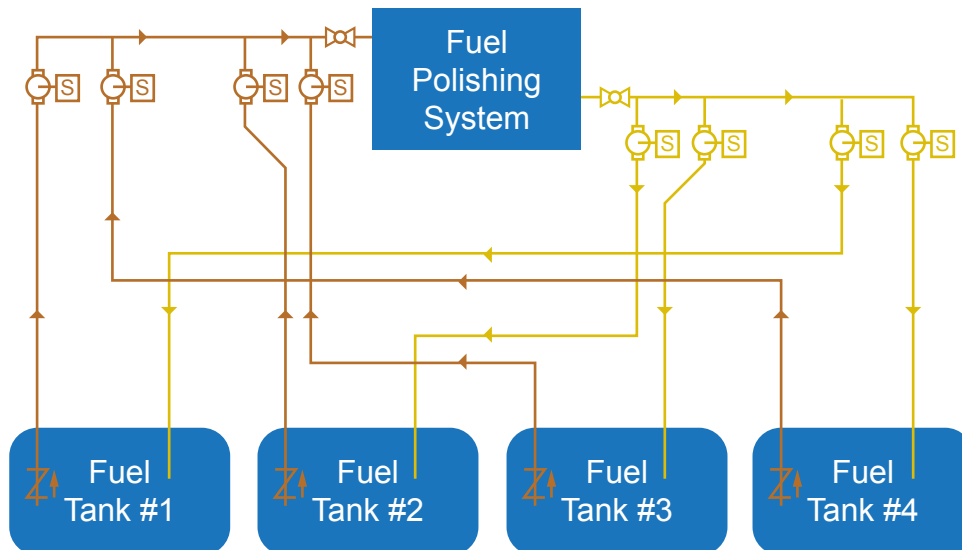

City of Puyallup Development & Permitting Services ISSUED PERMIT	
Building	Planning
Engineering	Public Works
Fire	Traffic

MODBUS Configuration Table (Siemens Digital Control)

Applies to digital control (not touchscreen).

Inputs

Inputs	Symbol	Description	Modbus Address
1	I1	Water Sensor	10001
2	I2	Spill Sensor	10002
3	I3	Auto Mode	10003
4	I4	Manual Mode	10004
5	I5	Stop	10005
6	I6	N/A	10006
7	I7	Pressure Switch	10007
8	I8	Vacuum Switch	10008

Outputs

Outputs	Symbol	Description	Modbus Address
1	Q1	Run Pump	8193
2	Q2	Buzzer/Red Light	8194
3	Q3	Blue Light	8195
4	Q4	Green Light	8196

Alarm As Individual Bits

Alarms	Symbol	Description	Modbus Address
1	M48	Water Sensor	8305
2	M49	Vacuum Switch	8306
3	M50	Pressure Switch	8307
4	M51	Spill Sensor	8308
5	M52	Pump Trip	8309

Remote Op

Remote Op	Symbol	Description	Modbus Address
1	M60	Remote Stop	8317
2	M61	Remote Alarm Reset	8318

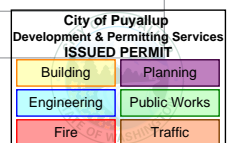

MODBUS Configuration Table (Siemens Touchscreen Control)

Applies to touchscreen control (not digital).

Inputs

Inputs	Symbol	Description	Modbus Address
1	I1	Water Sensor	10001
2	I2	Vacuum Switch	10002
3	I3	Pressure Switch	10003
4	I4	Spill Sensor	10004
5	I5	N/A	10005
6	I6	N/A	10006
7	I7	N/A	10007
8	I8	N/A	10008

Outputs

Outputs	Symbol	Description	Modbus Address
1	Q1	Run Pump	8193
2	Q2	Buzzer	8194
3	Q3	N/A	8195
4	Q4	N/A	8196

Alarm As Individual Bits

Alarms	Symbol	Description	Modbus Address
1	M48	Water Sensor	8305
2	M49	Vacuum Switch	8306
3	M50	Pressure Switch	8307
4	M51	Spill Sensor	8308
5	M52	Pump Trip	8309
6	M53	External Trip	8310

Remote Op

Remote Op	Symbol	Description	Modbus Address
1	M60	Remote Stop	8317
2	M61	Remote Alarm Reset	8318

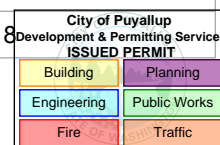

Applies to digital and touchscreen control.

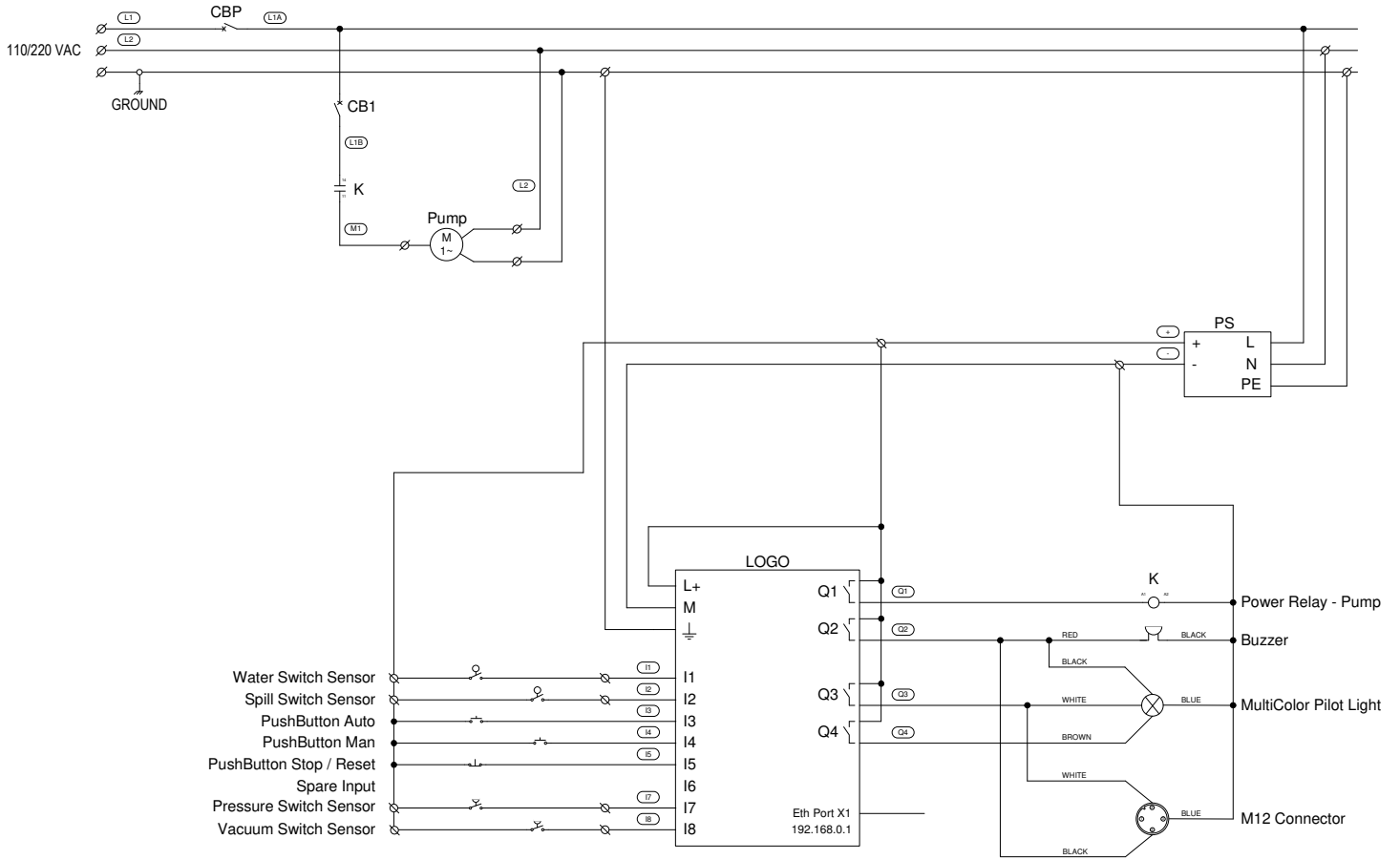

City of Puyallup
Development & Permitting Services
ISSUED PERMIT

Building	Planning
Engineering	Public Works
Fire	Traffic

Wiring

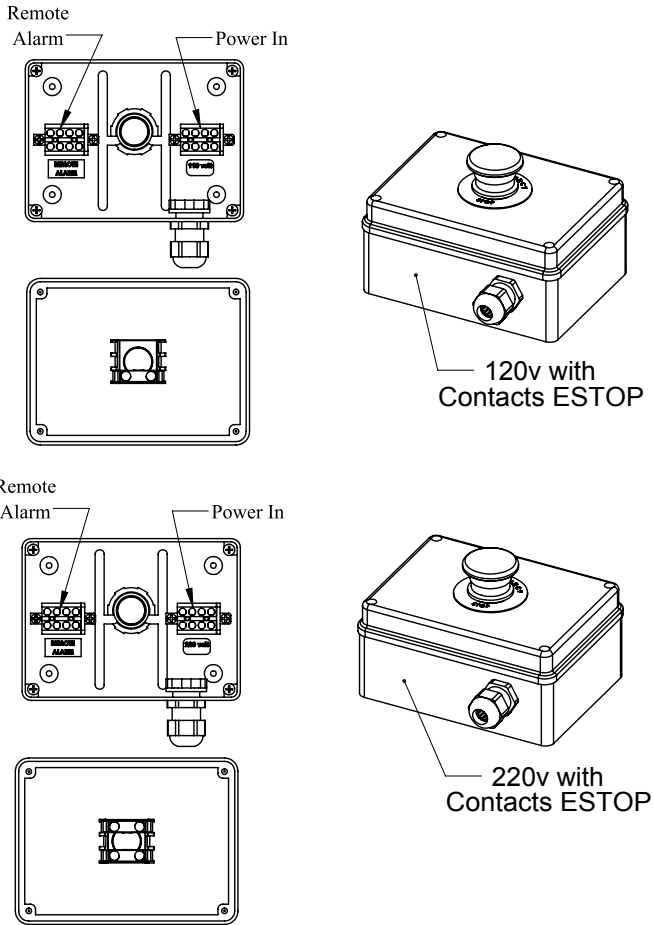
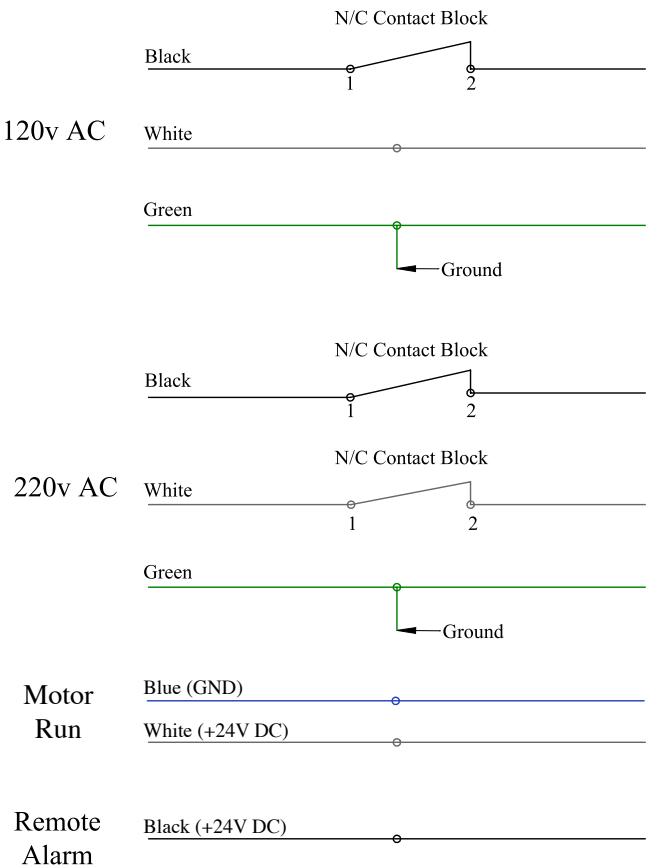

Dry Contact Relay Box

When this option is added (part # 40-40001), the remote alarm contact converts into a dry contact alarm.

- Installation of unit should only be performed by qualified installation personnel who have thoroughly read and understands the installation instructions covered in this manual.
- To avoid the risk of electric shock, make sure that the power supply is disconnected. Ensure that the power supply is at zero volts with a multimeter before making any electrical connections.
- To ensure operator safety the AFP must be connected to properly grounded power sources.
- Make sure that your unit and power supply are configured for the same voltage rating.
- Normally Open, Normally Closed, and Common dry contact relay connection points are available for customer use.
- Do not exceed 250VAC or 30VDC at 12 amps. Relay contact connection will indicate when motor is running and when alarm is activated.
- External voltage must be supplied by customer.

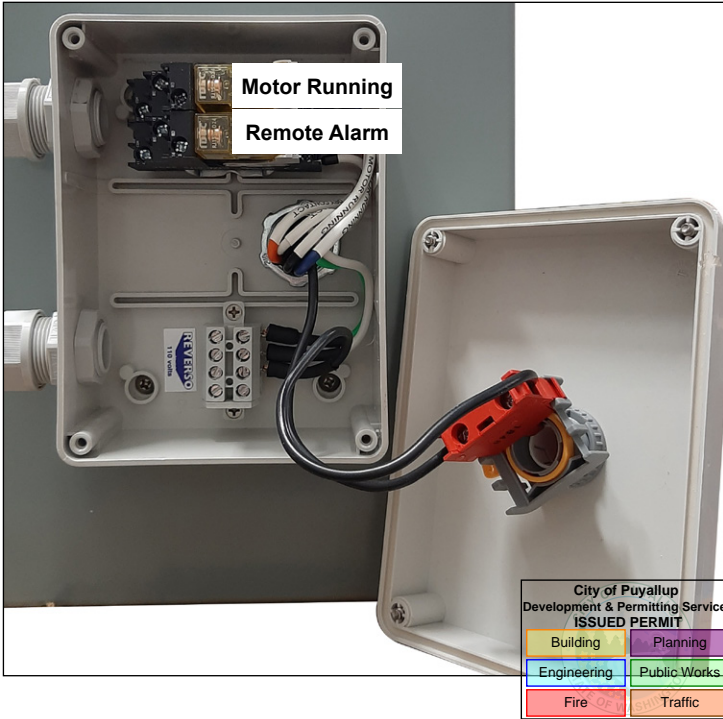

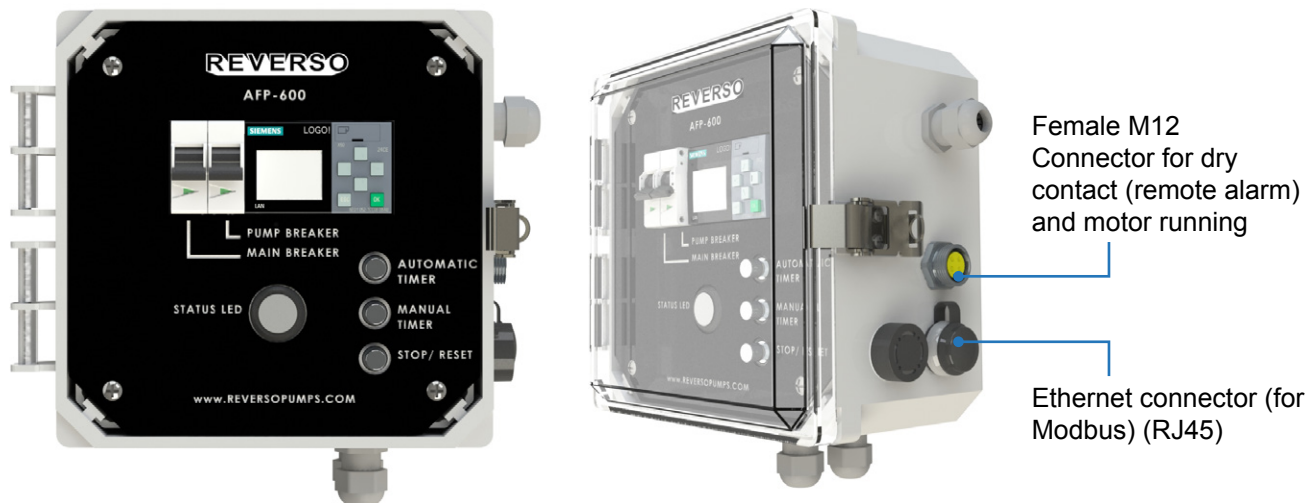

Overview

- Breaker for the system
- Breaker for the pump
- Siemens smart relay
- Timer push buttons: Automatic and Manual
- Stop/reset push button
- Status LED indicator lights:
 - Green: The unit is energized.
 - Red: Visible alarm, service system when triggered.
 - Blue: Pump is active, either manual or automatic mode. To verify that the pump is operating, check the vacuum gauge in a side of the filter, the gauge will be reading less than zero.
- Ethernet port
- Audio alarm

Alarms

- High vacuum: The vacuum switch on the system is set to -16 inHg. Once the system reaches this condition it is time to replace or backflush the element on the Separ Filter.
- High water level: When the water level reaches the maximum capacity on the filter bowl, the alarm will trigger. Proceed to drain the bowl.

If any alarm is triggered, proceed to de-energize the pump while servicing. Make sure to follow instructions listed in the manual.

Reset (Black Button)

- The buzzer will sound, and indicator light and the screen of the smart relay will be red and display the fault that is causing the alarm. Press black button to stop the buzzer alarm (audible alarm) indicator light will shut off but the smart relay remain on until the problem is solve.
- Use pump breaker to disconnect power from pump. Once the service is completed and the alarm issues resolved continue to next step.
- Press and hold black button for 3 second to reset the alarm.

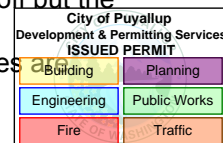

Set Date and Time

1. Make sure that the system is in Manual mode.
2. Press down arrow 2 times.
3. Press ESC.
4. Select Setup, press OK.
5. Select Clock, press OK.
6. Select Set clock, press OK. Use up/down arrows to select the number and right/left to move across the option. When done, press OK once.
7. Press ESC 3 times to go back to the main screen for manual mode.

Set Manual Timer

1. Press yellow button to go to manual mode. Amber color will be flashing.
2. Press down arrow to see the manual time set.
3. Press and hold ESC. Use arrow to change unit of time in minutes or hours. Press OK and change the desired time to run the system. When done, press ESC.
4. Press up arrow to go back to the principal screen.
5. Keep press yellow button to start the pump running the system with the set time. Pump will automatically shut off after the preset run time is over.
6. If the time must be reduced or increased while the system is running, repeat the steps to change the time for manual mode.

Manual Mode Operation

1. Select this mode to run the system for a single preset time. Press the yellow button once to put system into manual mode. The smart relay will be flashing amber.
2. Press and hold the yellow button for 3 seconds to start the pump for manual mode. Once solid, release the button and the smart relay will turn solid amber while the indicator light will turn blue. This indicates that the pump is running.
3. Pump will automatically shut off after the preset run time is over. User will need to put system back into automatic mode if desired.
4. If manual mode must be stopped while the system is running, press the red button Stop/Reset.

Automatic Mode Operation

The system will start/stop automatically on the programmed days of the week and times. To set up the frequency take into consideration the size of the tank and the environmental conditions. When the Automatic Timer is selected, the pump will only begin running if within programmed date/time to run.

For an initial cleaning, we recommend the tank to be cycled 3 times. Afterwards, the system can be run to cycle the fuel tank once per month, or more frequently based upon the environment, tank-housekeeping, and usage.

$$\text{Recommended Run Cycle (Manual Mode)} = \frac{\text{Volume of the tank} \times 3}{\text{Flow Rate of the System}}$$

Set Automatic Timer - Press green button to enter Automatic Mode

1. Press up/down arrow to view the days of the week.
2. Press ESC and hold for 3 seconds to set the dates and times for the selected day.
3. Use up/down arrow to go to ON time and OFF time. Press OK.
4. Change the hour using the left/right arrows to move the position on time, and use up/down arrows to change the number.
5. Press ESC twice to return to days of the week screen.
6. Repeat for every day that is schedule to run the system.
7. Press and hold green button for 3 seconds to start running the program.

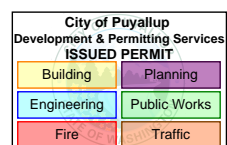



Female M12 Connector for dry contact (remote alarm) and motor running

Ethernet connector (for Modbus) (RJ45)

Main Menu

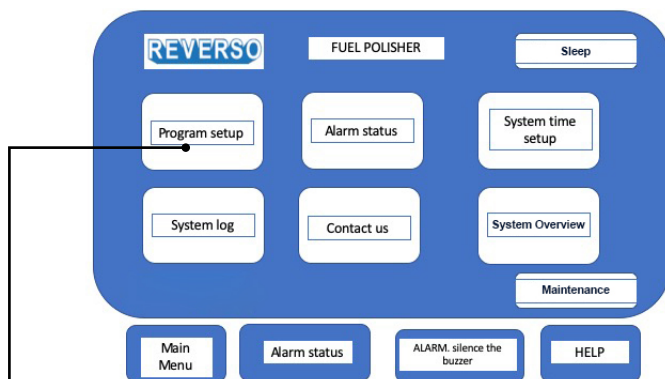

Program Setup

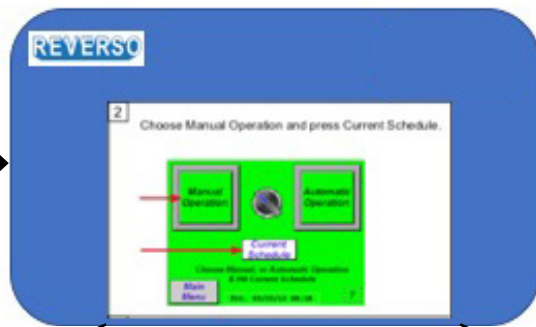

Select between manual and automatic operation.

Manual

Automatic

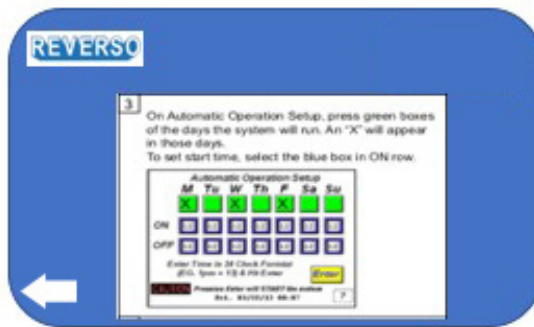
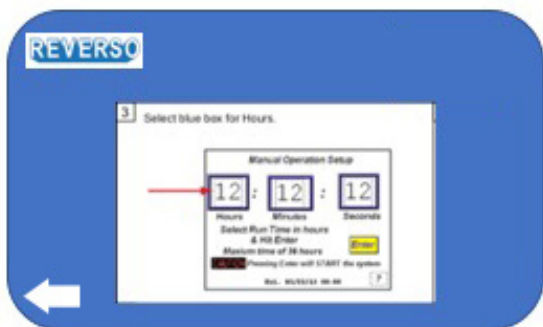

City of Puyallup Development & Permitting Services ISSUED PERMIT	
Building	Planning
Engineering	Public Works
Fire	Traffic

Main Menu

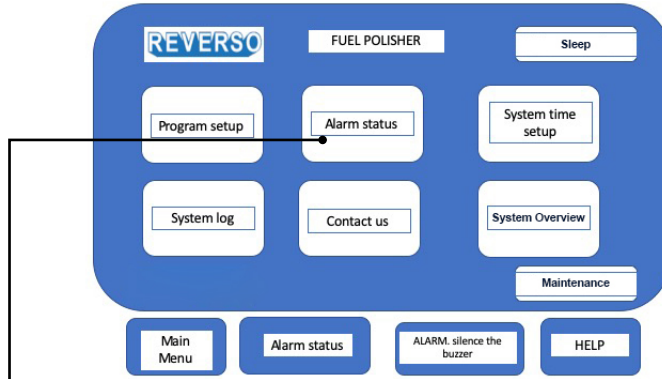

Alarm Status

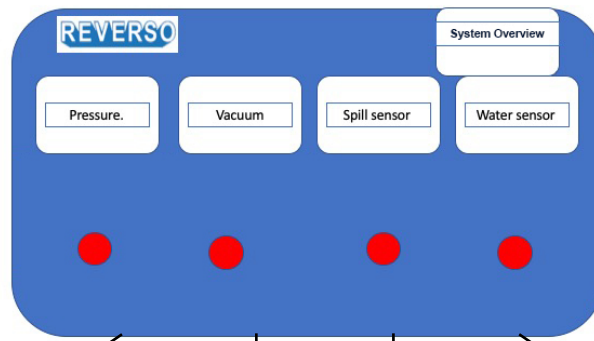

Pressure

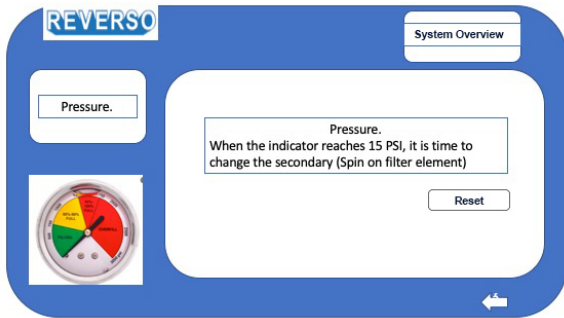

Water Sensor

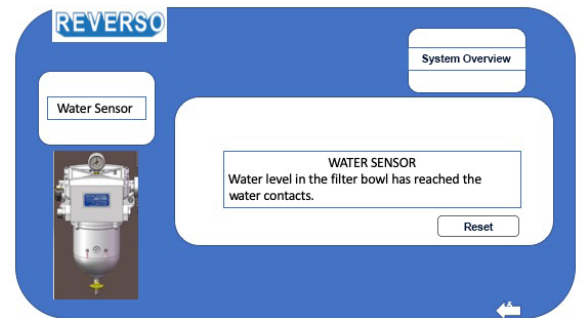

Vacuum

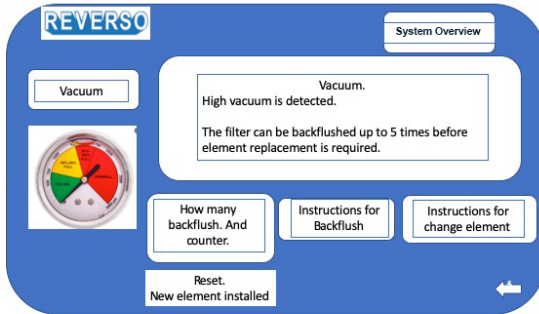

Spill Sensor

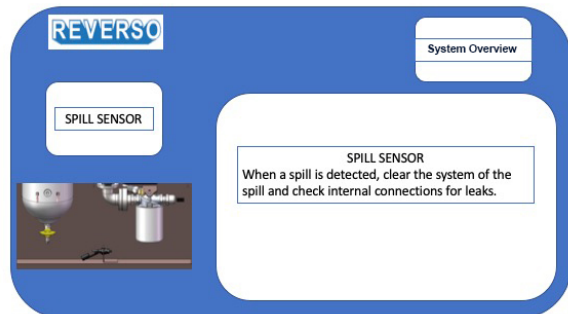

Note:

- Every 3rd high vacuum alarm, it will alert for filter element replacement. The number beside hi-vacuum indicates how many backflushing have been executed since the last element replacement.

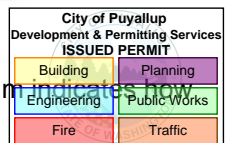

Main Menu

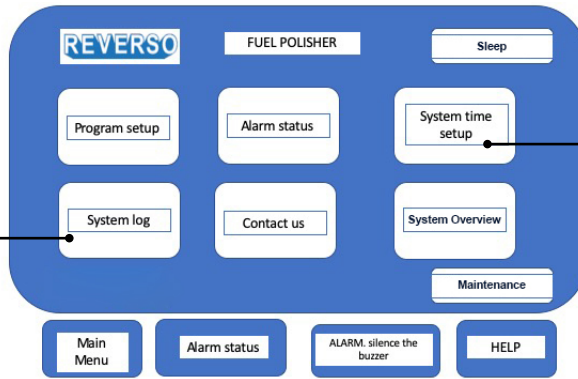

System Time Setup

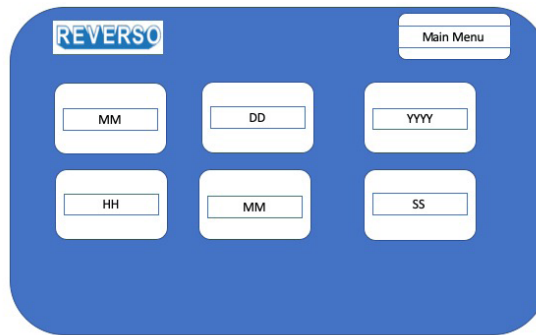

Set the current date and time.

System Log

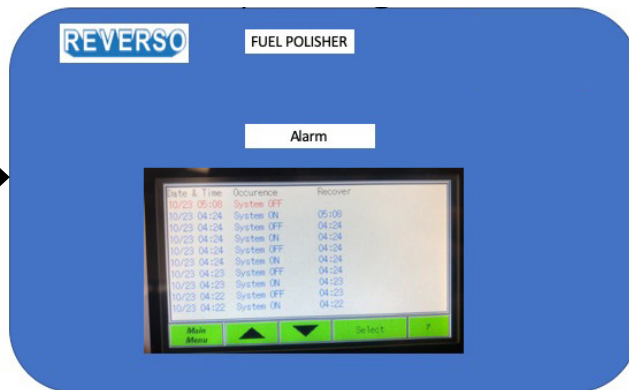

Alarm	Status
I	Sensor was OFF and turn ON
IO	Sensor was ON and turn OFF

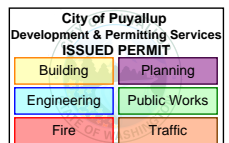

Main Menu

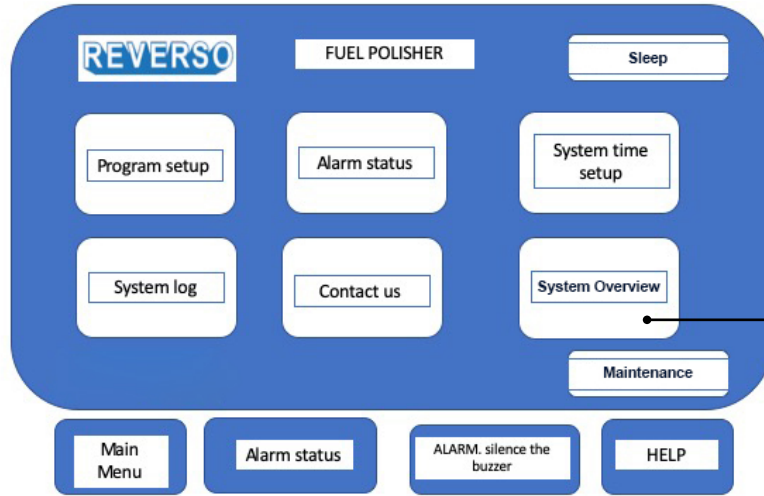

System Overview

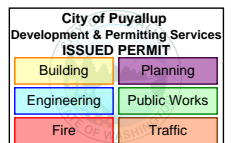
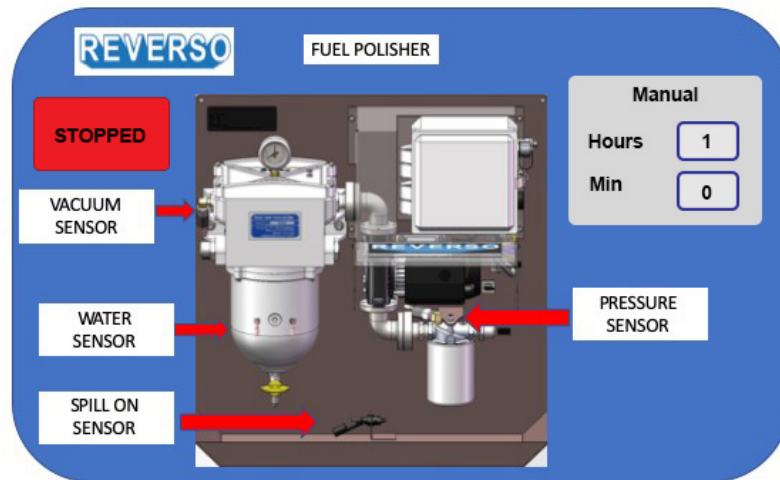

Main Menu

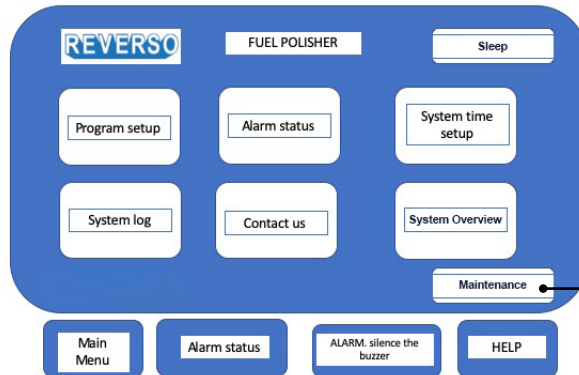

Maintenance

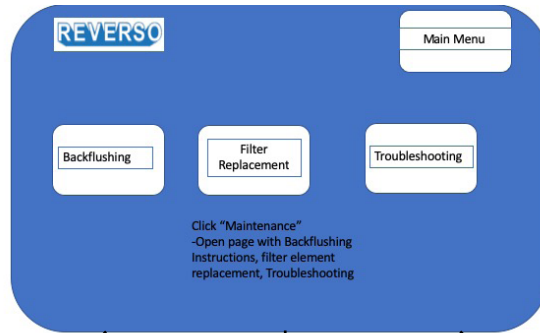

Backflushing

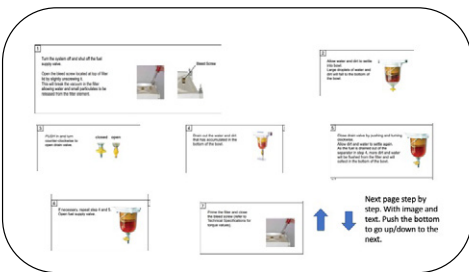

Filter Element Replacement

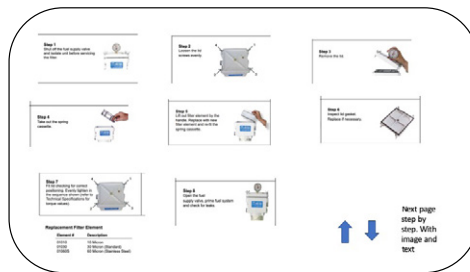

Troubleshooting

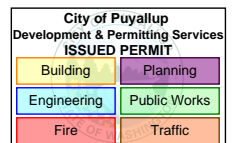
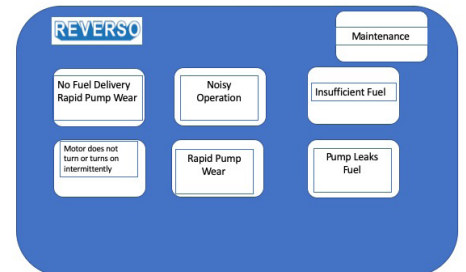

Backflushing

- Prior to service, ensure the system is off.
- Backflushing is for particulate removal only and will not remove sludge once embedded in the filter media.
- See Technical Specifications for torque recommendations.
- May be done up to 5 times until element replacement is required.

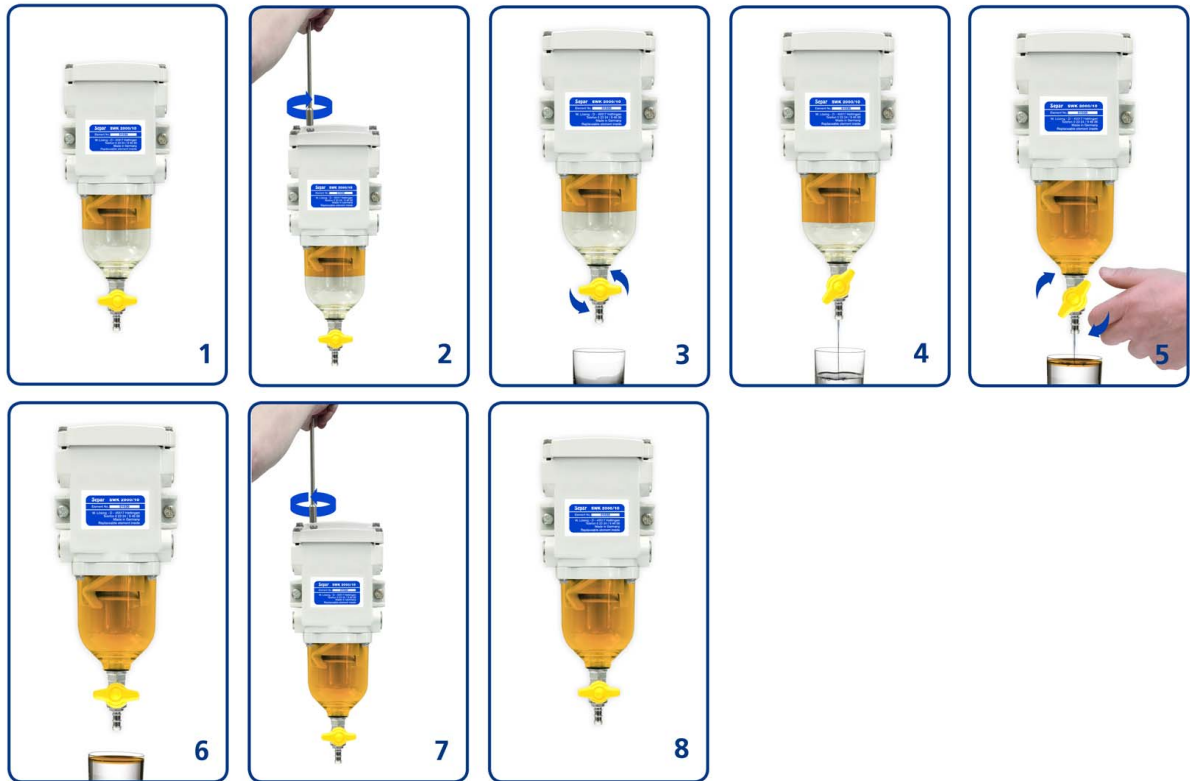

Filter Element Replacement

- Prior to service, ensure the system is off.
- See Technical Specifications for torque recommendations.

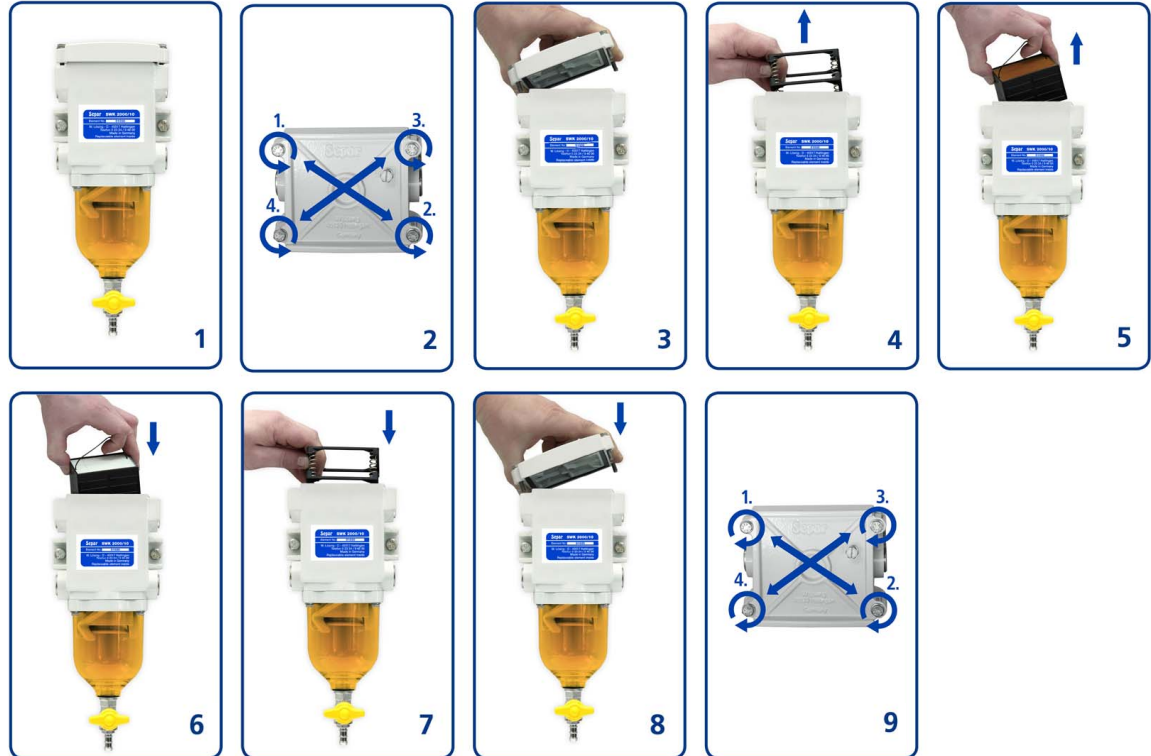

City of Puyallup Development & Permitting Services ISSUED PERMIT	
Building	Planning
Engineering	Public Works
Fire	Traffic

Prior to service, ensure the system is off.

1 Shut off the fuel supply valve and isolate unit before servicing the filter.

2 Unscrew used filter as shown.



3 Replace with new spin-on filter in the direction shown.



City of Puyallup Development & Permitting Services ISSUED PERMIT	
Building	Planning
Engineering	Public Works
Fire	Traffic

Vane Pump 620

Durable, self-priming, self-ventilated vane pump for diesel fuel only. Bypass and 100 micron filter is built into pump. Compact pump is ideal for dispensing or transferring diesel fuel. Suitable for continuous use with thermal motor and overload protection.

Basic Features

- Self-priming
- IP55 rated
- Equipped with On/off switch
- Available in 110V
- One-direction flow
- On/off switch



Technical Specifications

Flow Rate	10 GPM / 37.9 LPM	
Voltage	110V or 220V	
Ports	1" Female NPT	
Max. Suction Lift	11.5 ft / 3.5m with foot valve above liquid level	
Pressure	29 psi / 2 bar / 220V	
HP	1/2	
Watts	520 / 110V 350 / 220V	
Amperage	3.4A / 110V 2.5A / 220V	
Pump Type	Vane	
Body	Cast-iron	
Seal	Mechanical	
Motor	Induction	
Self-Priming	6.7 ft / 2 m (wet gears)	
Rated	IP55	
Dimensions	A	8.6" / 218 mm
	B	5.9" / 150 mm
	C	6.8" / 173 mm

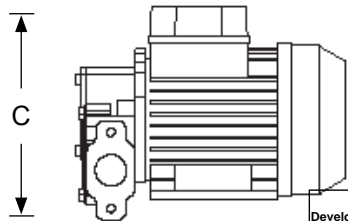
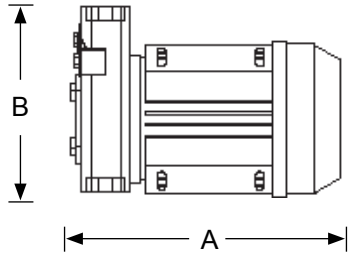

City of Puyallup
Development & Permitting Services
ISSUED PERMIT

Building	Planning
Engineering	Public Works
Fire	Traffic

SWK- 2000/40

Max. Flow Rate: 630 GPH (2,400 LPH)



- Separ 2000 series water separators fuel filters are a simple solution to many different fuel related problems.
- Five separate stages of filtration ensure 99.9% water separation (Certified TUV Report using SAE J1839) at maximum flow.
- Low restriction reduces wear on fuel pumps and ensures full RPMs.
- Backflushable (cleanable) element reduces down time and costly element changes.



Shown: top 2000/40MK
bottom 2000/40UM

Inlet / Outlet Connections

Single Unit: Metric M33x2 Female O-ring Boss
Duplex Unit: 35mm Tube x #20 MJIC Straight

Ordering Specifications

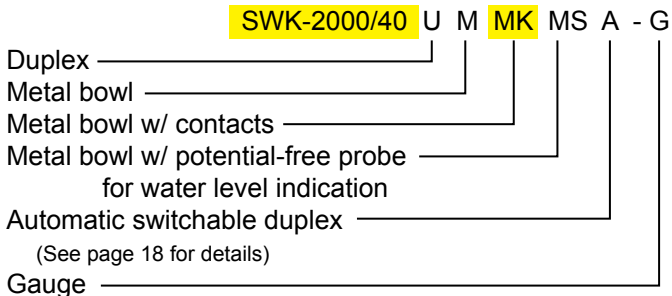

We reserve the right to alter the specification without prior notice.

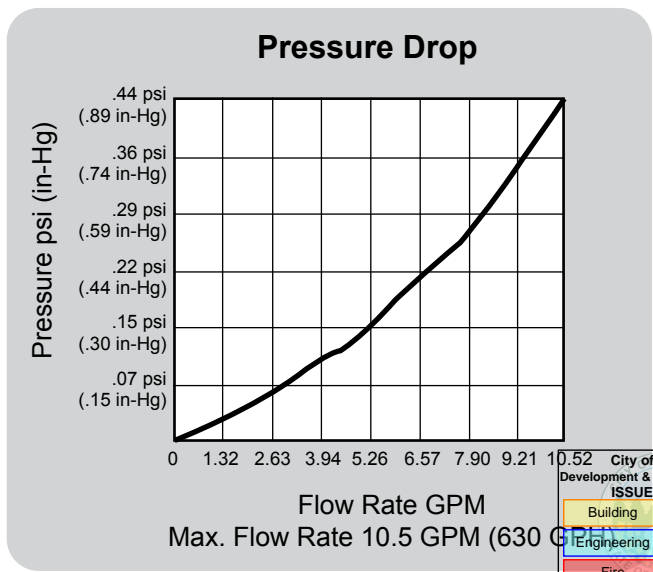

City of Puyallup
Development & Permitting Services
ISSUED PERMIT

Building	Planning
Engineering	Public Works
Fire	Traffic

Spin-On Filter

Spin-on filtration for particulate contaminant removal. Compatible for diesel and ultra-low sulfur diesel (ULSD). Equipped as secondary filtration in Reverso Automatic Fuel Polishing Systems. UL® rated for use with service station pumps and dispensers.



Shown without adapter

Available in

- 1 micron
- 2 micron

Technical Specifications

Flow Rate	Maximum 25 GPM / 94.6 LPM	
Max Work Pressure	50 psi / 6.4 bar	
1 micron	Part # 04-3382-01	
2 micron	Part # 04-3382	
Thread Type	1" - 12 UNF Thread	
Dimensions (without adapter)	Height	5.5" / 140 mm
	Diameter	3.75" / 95 mm
Adapter	Part # 04-3418	
Adapter Ports	3/4" NPT	
Adapter Material	Aluminum	

1" - 12 UNF Thread

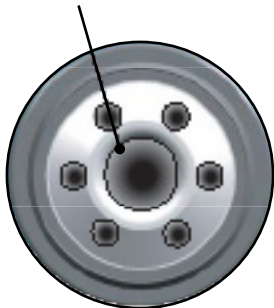

Top view without adapter

City of Puyallup
Development & Permitting Services
ISSUED PERMIT

Building	Planning
Engineering	Public Works
Fire	Traffic

Troubleshooting

Issue	Possible Causes and Action
Low / No Flow	<ul style="list-style-type: none"> Pump is worn or does not run. Pump and filter are not primed. Fuel supply or discharge line blocked. Check the alarm. Lift is too high. Air leak in fuel supply to pump. Inlet or outlet valve closed. Check the solenoid valve. Foot (check) valve installed backwards. Air leak at inlet. Piping improperly installed or dimensioned. Fuel water separator is clogged. Service filter.
Rapid pump wear	<ul style="list-style-type: none"> Pump has been run dry. Ensure sufficient fuel supply.
Noisy operation	<ul style="list-style-type: none"> Ensure sufficient fuel supply. Air in the suction hose. Check hose is submerged in the fuel or check for leak.
Motor does not turn or turns intermittently	<ul style="list-style-type: none"> Control power not available Tripped circuit breaker on control board Pump failed and seized Motor failure Check service switch is in the ON position (-)
Pump leaks fuel	<ul style="list-style-type: none"> Loose pump plumbing fittings Worn pump shaft seal Excessive heat from over head storage tank Worn pump o-rings or seals
Electrical	<ul style="list-style-type: none"> Verify voltage and fuse.

Warranty

For warranty policy and registration, please visit www.reversopumps.com

