

PRMU20240281 - BLDG F

BRADLEY HEIGHTS SS LLC

BRADLEY HEIGHTS APARTMENTS BUILDINGS 'A' Through 'H' 202 27th Avenue SE Puyallup, WA

FULL SIZED LEDGIBLE COLOR REPORT
IS REQUIRED TO BE PROVIDED BY THE
PERMITTEE ON SITE FOR ALL
INSPECTIONS

SUBMITTAL #2

Alliance Job # N0653

Date: Sept. 16, 2024

Representative: Craig Westerberg

**MiTek Canada, Inc.**

240 Stirling Crescent
Bradford, ON. Canada L3Z 4L5
Phone (905) 952-2900
Toll Free (800) 268-3434

Re: N0653A

Buildings A-H

The truss drawing(s) referenced below have been prepared by MiTek USA, Inc. under my direct supervision based on the parameters provided by Alliance Truss (CA).

Pages or sheets covered by this seal: U1530820 thru U1530901

My license renewal date for the state of Washington is February 17, 2026.



September 12, 2024

Garcia, Juan

IMPORTANT NOTE: The seal on these truss component designs is a certification that the engineer named is licensed in the jurisdiction(s) identified and that the designs comply with ANSI/TPI 1. These designs are based upon parameters shown (e.g., loads, supports, dimensions, shapes and design codes), which were given to MiTek or TRENCO. Any project specific information included is for MiTek's or TRENCO's customers file reference purpose only, and was not taken into account in the preparation of these designs. MiTek or TRENCO has not independently verified the applicability of the design parameters or the designs for any particular building. Before use, the building designer should verify applicability of design parameters and properly incorporate these designs into the overall building design per ANSI/TPI 1, Chapter 2.

**MiTek Canada, Inc.**

240 Stirling Crescent
Bradford, ON. Canada L3Z 4L5
Phone (905) 952-2900
Toll Free (800) 268-3434

Re: N0653A

Buildings A-H

The truss drawing(s) referenced below have been prepared by MiTek USA, Inc. under my direct supervision based on the parameters provided by Alliance Truss (CA).

Pages or sheets covered by this seal: U1530772 thru U1530819

My license renewal date for the state of Washington is February 17, 2026.



September 12, 2024

Garcia, Juan

IMPORTANT NOTE: The seal on these truss component designs is a certification that the engineer named is licensed in the jurisdiction(s) identified and that the designs comply with ANSI/TPI 1. These designs are based upon parameters shown (e.g., loads, supports, dimensions, shapes and design codes), which were given to MiTek or TRENCO. Any project specific information included is for MiTek's or TRENCO's customers file reference purpose only, and was not taken into account in the preparation of these designs. MiTek or TRENCO has not independently verified the applicability of the design parameters or the designs for any particular building. Before use, the building designer should verify applicability of design parameters and properly incorporate these designs into the overall building design per ANSI/TPI 1, Chapter 2.

Job	Truss	Truss Type	Qty	Ply	Buildings A-H
N0653A	A1	GABLE	7	1	U1530772

Alliance Truss (CA), Abbotsford, BC - V2S 7P6,

8.630 s Jul 12 2024 MiTek Industries, Inc. Thu Sep 12 02:47:23 2024 Page 2
ID:hFyjDMxrTsEK_kgkR0vWWVzFgc-RfC?PsB70Hq3NSgPqnL8w3ulTXbGKWrCDoi7J4zJC?f**NOTES-**

- 13) This truss has been designed for a total drag load of 240 plf. Lumber DOL=(1.33) Plate grip DOL=(1.33) Connect truss to resist drag loads along bottom chord from 18-5-8 to 30-11-8 for 594.4 plf.
- 14) No notches allowed in overhang and 10408 from left end and 0 from right end or 12" along rake from scarf, whichever is larger. Minimum 1.5x4 tie plates required at 2-0-0 o.c. maximum between the stacking chords. For edge-wise notching, provide at least one tie plate between each notch.



WARNING - Verify design parameters and READ NOTES ON THIS AND INCLUDED MITEK REFERENCE PAGE MII-7473 rev. 6/30/2020 BEFORE USE.

Design valid for use only with MiTek® connectors. This design is based only upon parameters shown, and is for an individual building component, not a truss system. Before use, the building designer must verify the applicability of design parameters and properly incorporate this design into the overall building design. Bracing indicated is to prevent buckling of individual truss web and/or chord members only. Additional temporary and permanent bracing is always required for stability and to prevent collapse with possible personal injury and property damage. For general guidance regarding the fabrication, storage, delivery, erection and bracing of trusses and truss systems, see

Safety Information available from Truss Plate Institute, 2670 Crain Highway, Suite 203 Waldorf, MD 20601

ANSI/TPI1 Quality Criteria, DSB-89 and BCSI Building Component



240 Stirling Crescent
Bradford, ON. L3Z 4L5

Job N0653A	Truss A2	Truss Type Common	Qty 28	Ply 1	Buildings A-H Job Reference (optional)	U1530773
---------------	-------------	----------------------	-----------	----------	---	----------

Alliance Truss (CA), Abbotsford, BC - V2S 7P6,

8.630 s Jul 12 2024 MiTek Industries, Inc. Thu Sep 12 02:47:23 2024 Page 1

ID:hFyjDMxRTsEK_kgkR0vWWWzFgC-RfC?PsB70Hq3NSgPqnL8w3ulTXbGKwRCDoi7J4zJC?f



Scale = 1:60.7

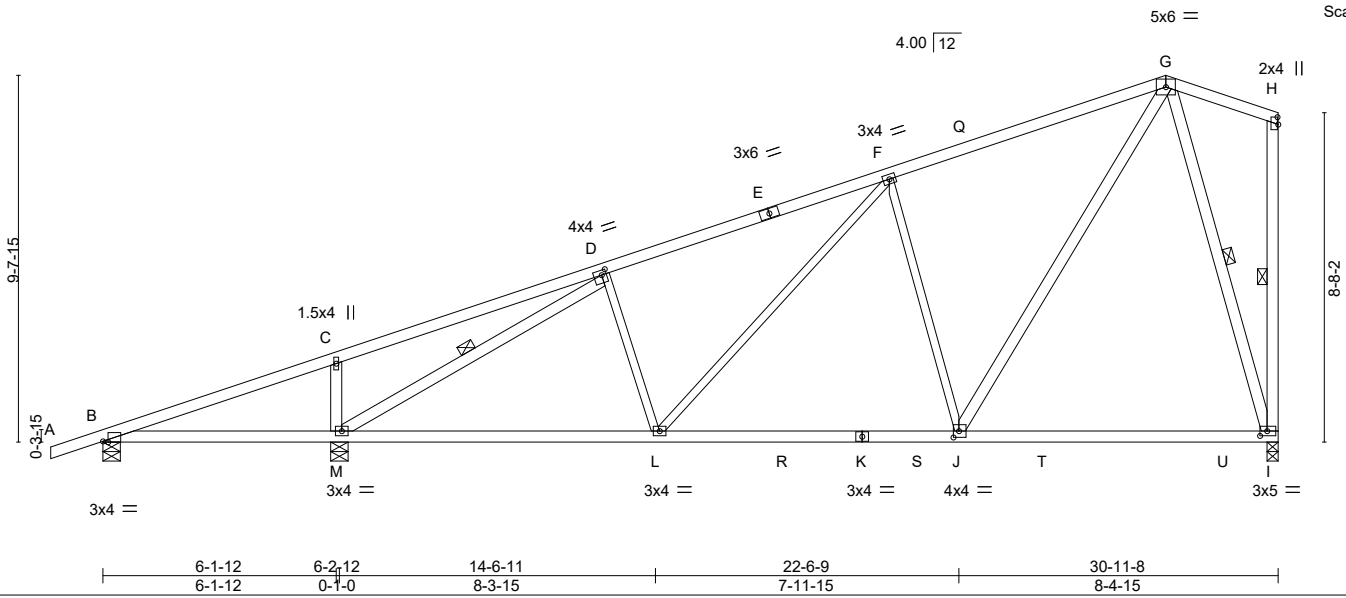

Plate Offsets (X,Y)-- [B:0-1-10,Edge], [D:0-1-8,0-1-8], [H:0-2-5,0-0-4], [I:0-2-4,0-1-8], [J:0-1-12,0-2-0]

LOADING (psf)		SPACING-		CSI.		DEFL.		PLATES		GRIP	
TCLL	25.0	Plate Grip DOL	1.15	TC	0.84	Vert(LL)	-0.23 I-J >999	L/d	360	MT20	197/144
(Roof Snow=25.0)		Lumber DOL	1.15	BC	0.80	Vert(CT)	-0.37 I-J >800		240		
TCDL	12.0	Rep Stress Incr	YES	WB	1.00	Horz(CT)	0.04 I n/a		n/a		
BCLL	0.0 *	Code IBC2018/TPI2014		Matrix-MS		Wind(LL)	0.04 J-L >999		240	Weight: 134 lb	FT = 20%
BCDL	10.0										

LUMBER-

TOP CHORD 2x4 SPF No.2
 BOT CHORD 2x4 SPF No.2
 WEBS 2x4 SPF No.2 *Except*
 D-L,F-L,F-J: 2x3 SPF No.2

BRACING-

TOP CHORD Structural wood sheathing directly applied or 3-6-8 oc purlins, except end verticals.
 BOT CHORD Rigid ceiling directly applied or 10-0-0 oc bracing, Except: 6-0-0 oc bracing: B-M.
 WEBS 1 Row at midpt D-M, H-I, G-I

REACTIONS.

(size) B=0-5-8, M=0-5-8, I=0-3-8
 Max Horz B=276(LC 9)
 Max Uplift B=-48(LC 6), M=-200(LC 10), I=-135(LC 6)
 Max Grav B=300(LC 1), M=1668(LC 3), I=1254(LC 3)

FORCES. (lb) - Max. Comp./Max. Ten. - All forces 250 (lb) or less except when shown.

TOP CHORD D-F=-1523/194, F-G=-1101/187
 BOT CHORD L-M=-179/1377, J-L=-126/1136, I-J=-87/337
 WEBS C-M=-513/167, D-M=-1746/193, F-L=-48/388, F-J=-782/218, G-J=-150/1234, G-I=-1135/137

NOTES-

- 1) Wind: ASCE 7-16; Vult=115mph (3-second gust) Vasd=91mph; TCDL=4.2psf; BCDL=5.0psf; h=30ft; Ke=1.00; Cat. II; Exp B; Enclosed; MWFRS (envelope) gable end zone; cantilever left and right exposed; end vertical left and right exposed; Lumber DOL=1.33 plate grip DOL=1.33
- 2) TCLL: ASCE 7-16; Pf=25.0 psf (Lum DOL=1.15 Plate DOL=1.15); Is=1.0; Rough Cat B; Partially Exp.; Ce=1.0; Cs=1.00; Ct=1.10
- 3) Unbalanced snow loads have been considered for this design.
- 4) This truss has been designed for greater of min roof live load of 20.0 psf or 2.00 times flat roof load of 25.0 psf on overhangs non-concurrent with other live loads.
- 5) This truss has been designed for a 10.0 psf bottom chord live load nonconcurrent with any other live loads.
- 6) * This truss has been designed for a live load of 20.0psf on the bottom chord in all areas where a rectangle 3-6-0 tall by 2-0-0 wide will fit between the bottom chord and any other members, with BCDL = 10.0psf.
- 7) Provide mechanical connection (by others) of truss to bearing plate capable of withstanding 100 lb uplift at joint(s) B except (jt=lb) M=200, I=135.
- 8) This truss is designed in accordance with the 2018 International Building Code section 2306.1 and referenced standard ANSI/TPI 1.



September 12, 2024

WARNING - Verify design parameters and READ NOTES ON THIS AND INCLUDED MITEK REFERENCE PAGE MII-7473 rev. 6/30/2020 BEFORE USE.

Design valid for use only with MiTek® connectors. This design is based only upon parameters shown, and is for an individual building component, not a truss system. Before use, the building designer must verify the applicability of design parameters and properly incorporate this design into the overall building design. Bracing indicated is to prevent buckling of individual truss web and/or chord members only. Additional temporary and permanent bracing is always required for stability and to prevent collapse with possible personal injury and property damage. For general guidance regarding the fabrication, storage, delivery, erection and bracing of trusses and truss systems, see **ANSI/TPI1 Quality Criteria, DSB-89 and BCSI Building Component Safety Information** available from Truss Plate Institute, 2670 Crain Highway, Suite 203 Waldorf, MD 20601



Job N0653A	Truss A3	Truss Type Common	Qty 5	Ply 1	Buildings A-H Job Reference (optional)	U1530820
---------------	-------------	----------------------	----------	----------	---	----------

Alliance Truss (CA), Abbotsford, BC - V2S 7P6, 8.820 s Aug 30 2024 MiTek Industries, Inc. Thu Sep 12 02:47:57 2024 Page 1

ID:hFyjDMxrTsEK_kgkR0vWWVzFlgc-vz5Z0lyb6AhmTLfrZVJ67B8yBDzpGD1DDm9qWvyeVrG

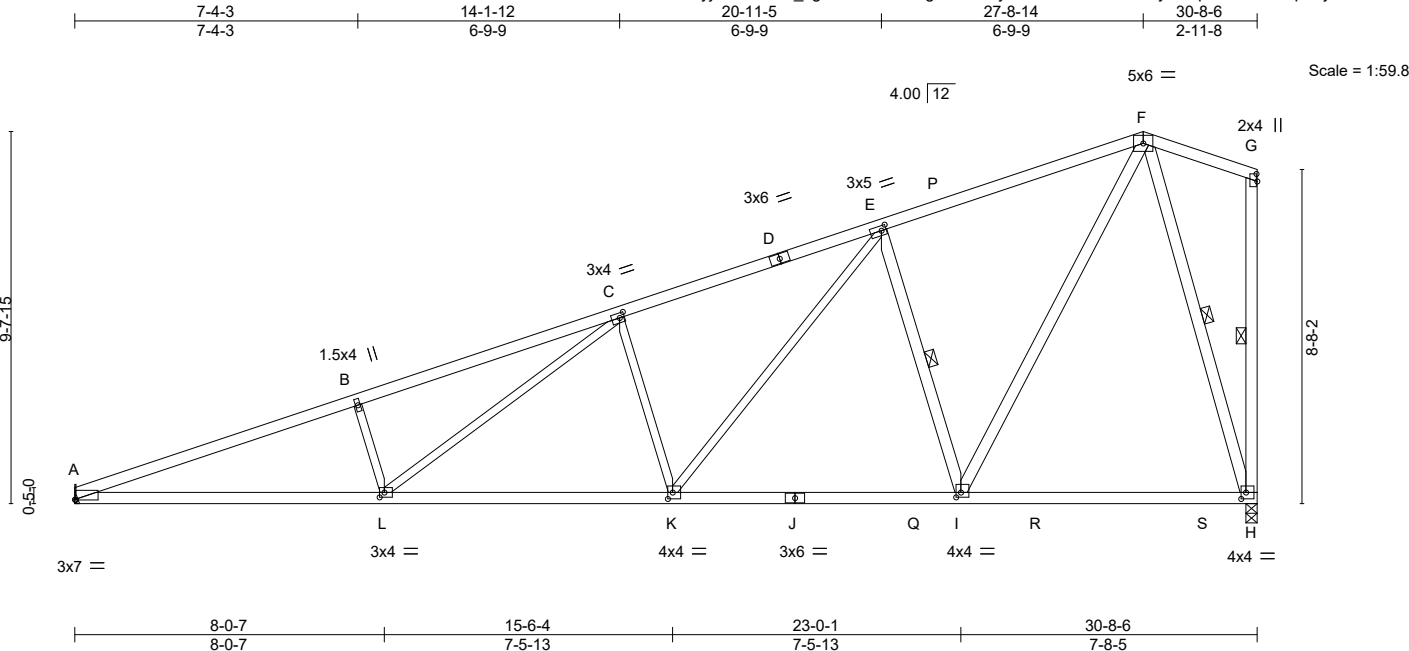

Plate Offsets (X,Y)--	[A:0-0-4,0-0-2], [C:0-1-8,0-1-8], [E:0-1-8,0-1-8], [G:0-2-5,0-0-4], [H:0-1-8,0-2-0], [I:0-1-8,0-1-8], [K:0-1-8,0-2-0], [L:0-1-8,0-1-8]
-----------------------	--

LOADING (psf)	SPACING-	CSI.	DEFL.	PLATES	GRIP
TCLL 25.0 (Roof Snow=25.0)	2-0-0 Plate Grip DOL 1.15 Lumber DOL 1.15 Rep Stress Incr YES Code IBC2018/TPI2014	TC 0.76 BC 0.80 WB 0.65 Matrix-MS	in (loc) l/defl L/d Vert(LL) -0.23 K-L >999 360 Vert(CT) -0.42 K-L >866 240 Horz(CT) 0.08 H n/a n/a Wind(LL) 0.12 K-L >999 240	MT20	197/144
TCDL 12.0				Weight: 131 lb	FT = 20%
BCLL 0.0 *					
BCDL 10.0					

LUMBER-	BRACING-
TOP CHORD 2x4 SPF No.2	TOP CHORD Structural wood sheathing directly applied or 2-2-0 oc purlins, except end verticals.
BOT CHORD 2x4 SPF No.2 *Except*	BOT CHORD Rigid ceiling directly applied or 10-0-0 oc bracing.
WEBS 2x4 SPF No.2 *Except*	WEBS 1 Row at midpt E-I, G-H, F-H
B-L, C-L, C-K, E-K: 2x3 SPF No.2	

REACTIONS. (size) A=Mechanical, H=0-3-8
 Max Horz A=267(LC 9)
 Max Uplift A=-160(LC 6), H=-174(LC 6)
 Max Grav A=1510(LC 3), H=1568(LC 3)

FORCES. (lb) - Max. Comp./Max. Ten. - All forces 250 (lb) or less except when shown.
 TOP CHORD A-B=-3666/396, B-C=-3552/421, C-E=-2448/316, E-F=-1332/215
 BOT CHORD A-L=-460/3419, K-L=-303/2468, I-K=-151/1509, H-I=-88/433
 WEBS B-L=-491/167, C-L=-141/1068, C-K=-815/207, E-K=-156/1253, E-I=-1223/264, F-I=-201/1661, F-H=-1472/172

- NOTES-**
- 1) Wind: ASCE 7-16; Vult=115mph (3-second gust) Vasd=91mph; TCDL=4.2psf; BCDL=5.0psf; h=30ft; Ke=1.00; Cat. II; Exp B; Enclosed; MWFRS (envelope) gable end zone; cantilever left and right exposed ; end vertical left and right exposed; Lumber DOL=1.33 plate grip DOL=1.33
 - 2) TCLL: ASCE 7-16; Pf=25.0 psf (Lum DOL = 1.15 Plate DOL = 1.15); Is=1.0; Rough Cat B; Partially Exp.; Ce=1.0; Cs=1.00; Ct=1.10
 - 3) Unbalanced snow loads have been considered for this design.
 - 4) This truss has been designed for a 10.0 psf bottom chord live load nonconcurrent with any other live loads.
 - 5) * This truss has been designed for a live load of 20.0psf on the bottom chord in all areas where a rectangle 3-6-0 tall by 2-0-0 wide will fit between the bottom chord and any other members, with BCDL = 10.0psf.
 - 6) Refer to girder(s) for truss to truss connections.
 - 7) Provide mechanical connection (by others) of truss to bearing plate capable of withstanding 100 lb uplift at joint(s) except (jt=lb) A=160, H=174.
 - 8) This truss is designed in accordance with the 2018 International Building Code section 2306.1 and referenced standard ANSI/TPI 1.



September 12, 2024

WARNING - Verify design parameters and READ NOTES ON THIS AND INCLUDED MITEK REFERENCE PAGE MII-7473 rev. 6/30/2020 BEFORE USE.

Design valid for use only with MiTek® connectors. This design is based only upon parameters shown, and is for an individual building component, not a truss system. Before use, the building designer must verify the applicability of design parameters and properly incorporate this design into the overall building design. Bracing indicated is to prevent buckling of individual truss web and/or chord members only. Additional temporary and permanent bracing is always required for stability and to prevent collapse with possible personal injury and property damage. For general guidance regarding the fabrication, storage, delivery, erection and bracing of trusses and truss systems, see **ANSI/TPI1 Quality Criteria, DSB-89 and BCSI Building Component Safety Information** available from Truss Plate Institute, 2670 Crain Highway, Suite 203 Waldorf, MD 20601

240 Stirling Crescent
Bradford, ON. L3Z 4L5

Job	Truss	Truss Type	Qty	Ply	Buildings A-H	U1530821
N0653A	A3A	Scissor	30	1		

Alliance Truss (CA), Abbotsford, BC - V2S 7P6, 8.820 s Aug 30 2024 MiTek Industries, Inc. Thu Sep 12 02:47:58 2024 Page 1

ID:hFyjDMxrTsEK_kgkR0vWWVzFlgc-NAfxE5zDTpc5VE27CqLgPh7fdIP?eJMRQvO2MMyeVrF

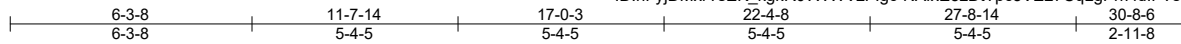

Scale = 1:60.0

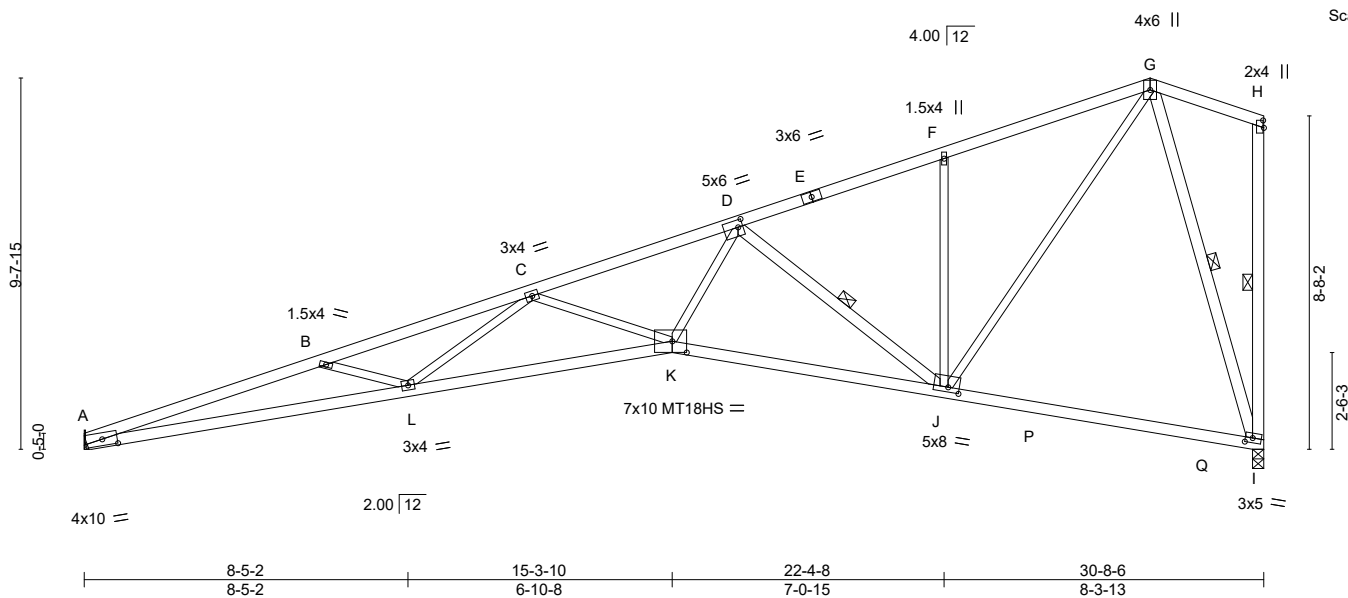

Plate Offsets (X,Y)-- [A:0-4-11,0-2-0], [D:0-1-8,0-2-4], [H:0-2-5,0-0-4], [I:0-2-4,0-1-8], [J:0-3-8,0-1-8], [K:0-4-8,0-3-8]

LOADING (psf)	SPACING-	CSI.	DEFL.	PLATES	GRIP
TCLL 25.0 (Roof Snow=25.0)	2-0-0 Plate Grip DOL 1.15	TC 0.71	in (loc) l/defl L/d	MT20	197/144
TCDL 12.0	Lumber DOL 1.15	BC 0.84	Vert(LL) -0.57 K-L >639 360	MT18HS	197/144
BCLL 0.0 *	Rep Stress Incr YES	WB 0.77	Vert(CT) -1.04 K-L >351 240		
BCDL 10.0	Code IBC2018/TPI2014	Matrix-MS	Horz(CT) 0.43 I n/a n/a		
			Wind(LL) 0.31 K-L >999 240	Weight: 124 lb	FT = 20%

LUMBER-

TOP CHORD 2x4 SPF No.2 *Except*
A-E: 2x4 SPF 2100F 1.8E
BOT CHORD 2x4 SPF 2100F 1.8E
WEBS 2x3 SPF No.2 *Except*
D-J,H-I,G-I: 2x4 SPF No.2

BRACING-

TOP CHORD Structural wood sheathing directly applied or 2-3-6 oc purlins, except end verticals.
BOT CHORD Rigid ceiling directly applied or 8-3-13 oc bracing.
WEBS 1 Row at midpt D-J, H-I, G-I

REACTIONS.

(size) A=Mechanical, I=0-3-8
Max Horz A=268(LC 9)
Max Uplift A=-160(LC 6), I=-174(LC 6)
Max Grav A=1496(LC 3), I=1541(LC 3)

FORCES. (lb) - Max. Comp./Max. Ten. - All forces 250 (lb) or less except when shown.

TOP CHORD A-B=-6536/821, B-C=-6142/686, C-D=-4578/532, D-F=-1696/209, F-G=-1723/270
BOT CHORD A-L=-887/6230, K-L=-705/5293, J-K=-394/3304, I-J=-98/475
WEBS B-L=-456/187, C-L=-4/776, C-K=-1007/216, D-K=-229/2254, D-J=-2182/333,
F-J=-504/147, G-J=-253/2028, G-I=-1485/166

NOTES-

- 1) Wind: ASCE 7-16; Vult=115mph (3-second gust) Vasd=91mph; TCDL=4.2psf; BCDL=5.0psf; h=30ft; Ke=1.00; Cat. II; Exp B; Enclosed; MWFRS (envelope) gable end zone; cantilever left and right exposed ; end vertical left and right exposed; Lumber DOL=1.33 plate grip DOL=1.33
- 2) TCLL: ASCE 7-16; Pf=25.0 psf (Lum DOL = 1.15 Plate DOL = 1.15); Is=1.0; Rough Cat B; Partially Exp.; Ce=1.0; Cs=1.00; Ct=1.10
- 3) Unbalanced snow loads have been considered for this design.
- 4) All plates are MT20 plates unless otherwise indicated.
- 5) This truss has been designed for a 10.0 psf bottom chord live load nonconcurrent with any other live loads.
- 6) * This truss has been designed for a live load of 20.0psf on the bottom chord in all areas where a rectangle 3-6-0 tall by 2-0-0 wide will fit between the bottom chord and any other members, with BCDL = 10.0psf.
- 7) Refer to girder(s) for truss to truss connections.
- 8) Bearing at joint(s) I considers parallel to grain value using ANSI/TPI 1 angle to grain formula. Building designer should verify capacity of bearing surface.
- 9) Provide mechanical connection (by others) of truss to bearing plate capable of withstanding 100 lb uplift at joint(s) except (jt=lb) A=160, I=174.
- 10) This truss is designed in accordance with the 2018 International Building Code section 2306.1 and referenced standard ANSI/TPI 1.



September 12, 2024

WARNING - Verify design parameters and READ NOTES ON THIS AND INCLUDED MITEK REFERENCE PAGE MII-7473 rev. 6/30/2020 BEFORE USE.

Design valid for use only with MiTek® connectors. This design is based only upon parameters shown, and is for an individual building component, not a truss system. Before use, the building designer must verify the applicability of design parameters and properly incorporate this design into the overall building design. Bracing indicated is to prevent buckling of individual truss web and/or chord members only. Additional temporary and permanent bracing is always required for stability and to prevent collapse with possible personal injury and property damage. For general guidance regarding the fabrication, storage, delivery, erection and bracing of trusses and truss systems, see ANSI/TPI1 Quality Criteria, DSB-89 and BCSI Building Component

Safety Information available from Truss Plate Institute, 2670 Crain Highway, Suite 203 Waldorf, MD 20601



240 Stirling Crescent
Bradford, ON. L3Z 4L5

Job N0653A	Truss A4	Truss Type Common	Qty 30	Ply 1	Buildings A-H Job Reference (optional)	U1530822
---------------	-------------	----------------------	-----------	----------	---	----------

Alliance Truss (CA), Abbotsford, BC - V2S 7P6, 8.820 s Aug 30 2024 MiTek Industries, Inc. Thu Sep 12 02:47:58 2024 Page 1

ID:hFyjDMxrTsEK_kgkR0vWWVzFgC-NAfxE5zDtTpc5VE27CqLgPh5idJ_?gFMRQvO2MyeVrF

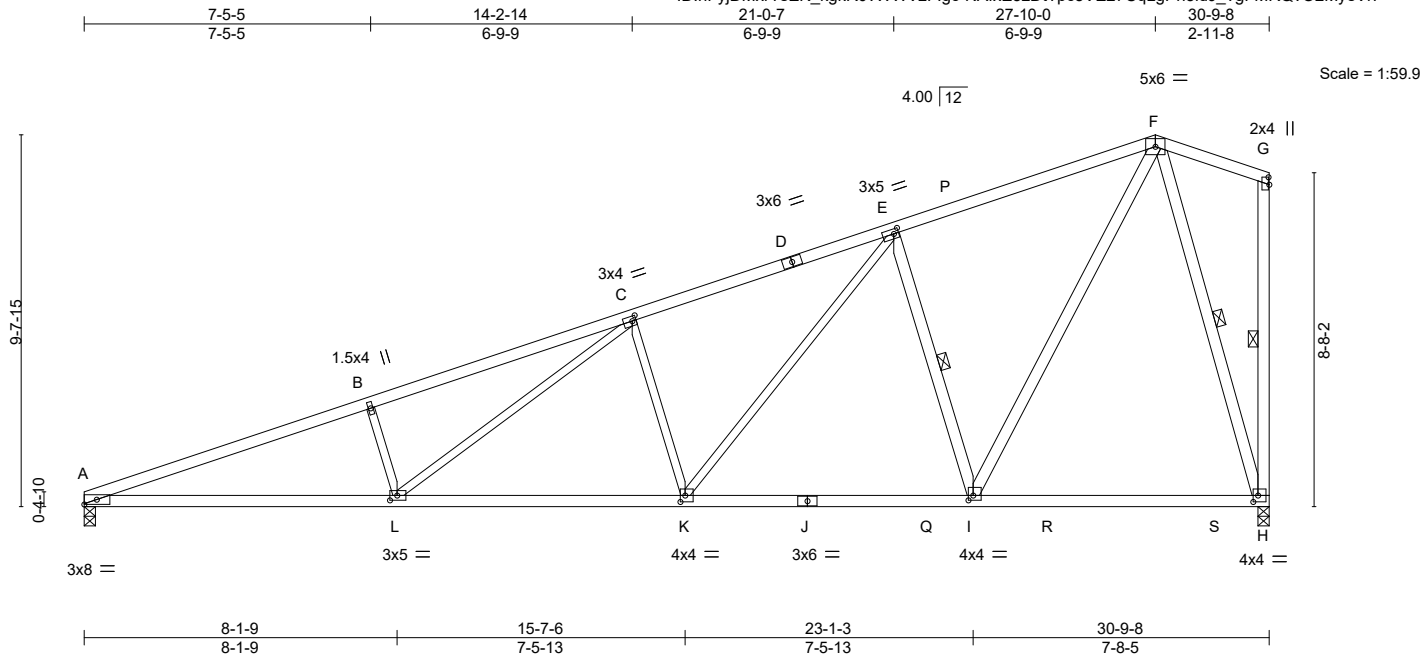

Plate Offsets (X,Y)-- [C:0-1-4,0-1-8], [E:0-1-8,0-1-8], [G:0-2-5,0-0-4], [H:0-1-8,0-2-0], [I:0-1-8,0-1-8], [K:0-1-8,0-2-0], [L:0-2-4,0-1-8]

LOADING (psf)	SPACING-	CSI.	DEFL.	PLATES	GRIP
TCLL 25.0 (Roof Snow=25.0)	2-0-0 Plate Grip DOL 1.15	TC 0.84	in (loc) l/defl L/d	MT20	197/144
TCDL 12.0	Lumber DOL 1.15	BC 0.80	Vert(LL) -0.23 K-L >999 360		
BCLL 0.0 *	Rep Stress Incr YES	WB 0.65	Vert(CT) -0.42 K-L >873 240		
BCDL 10.0	Code IBC2018/TPI2014	Matrix-MS	Horz(CT) 0.08 H n/a n/a		
			Wind(LL) 0.12 L >999 240	Weight: 131 lb	FT = 20%

LUMBER-

TOP CHORD 2x4 SPF No.2
 BOT CHORD 2x4 SPF No.2 *Except*
 A-J: 2x4 SPF 2100F 1.8E
 WEBS 2x4 SPF No.2 *Except*
 B-L,C-L,C-K,E-K: 2x3 SPF No.2

BRACING-

TOP CHORD Structural wood sheathing directly applied or 2-2-0 oc purlins, except end verticals.
 BOT CHORD Rigid ceiling directly applied or 10-0-0 oc bracing.
 WEBS 1 Row at midpt E-I, G-H, F-H

REACTIONS.

(size) A=0-3-8, H=0-3-8
 Max Horz A=268(LC 9)
 Max Uplift A=-161(LC 6), H=-175(LC 6)
 Max Grav A=1514(LC 3), H=1572(LC 3)

FORCES. (lb) - Max. Comp./Max. Ten. - All forces 250 (lb) or less except when shown.

TOP CHORD A-B=-3719/402, B-C=-3606/427, C-E=-2460/317, E-F=-1337/216
 BOT CHORD A-L=-465/3472, K-L=-305/2483, I-K=-152/1515, H-I=-88/434
 WEBS B-L=-503/168, C-L=-146/1113, C-K=-826/208, E-K=-157/1262, E-I=-1229/265,
 F-I=-201/1669, F-H=-1477/172

NOTES-

- 1) Wind: ASCE 7-16; Vult=115mph (3-second gust) Vasd=91mph; TCDL=4.2psf; BCDL=5.0psf; h=30ft; Ke=1.00; Cat. II; Exp B; Enclosed; MWFRS (envelope) gable end zone; cantilever left and right exposed ; end vertical left and right exposed; Lumber DOL=1.33 plate grip DOL=1.33
- 2) TCLL: ASCE 7-16; Pf=25.0 psf (Lum DOL = 1.15 Plate DOL = 1.15); Is=1.0; Rough Cat B; Partially Exp.; Ce=1.0; Cs=1.00; Ct=1.10
- 3) Unbalanced snow loads have been considered for this design.
- 4) This truss has been designed for a 10.0 psf bottom chord live load nonconcurrent with any other live loads.
- 5) * This truss has been designed for a live load of 20.0psf on the bottom chord in all areas where a rectangle 3-6-0 tall by 2-0-0 wide will fit between the bottom chord and any other members, with BCDL = 10.0psf.
- 6) Provide mechanical connection (by others) of truss to bearing plate capable of withstanding 100 lb uplift at joint(s) except (jt=lb) A=161, H=175.
- 7) This truss is designed in accordance with the 2018 International Building Code section 2306.1 and referenced standard ANSI/TPI 1.



September 12, 2024

WARNING - Verify design parameters and READ NOTES ON THIS AND INCLUDED MITEK REFERENCE PAGE MII-7473 rev. 6/30/2020 BEFORE USE.

Design valid for use only with MiTek® connectors. This design is based only upon parameters shown, and is for an individual building component, not a truss system. Before use, the building designer must verify the applicability of design parameters and properly incorporate this design into the overall building design. Bracing indicated is to prevent buckling of individual truss web and/or chord members only. Additional temporary and permanent bracing is always required for stability and to prevent collapse with possible personal injury and property damage. For general guidance regarding the fabrication, storage, delivery, erection and bracing of trusses and truss systems, see **ANSI/TPI1 Quality Criteria, DSB-89 and BCSI Building Component Safety Information** available from Truss Plate Institute, 2670 Crain Highway, Suite 203 Waldorf, MD 20601



240 Stirling Crescent
 Bradford, ON. L3Z 4L5

Job	Truss	Truss Type	Qty	Ply	Buildings A-H	U1530823
N0653A	A5	GABLE	5	1		

Alliance Truss (CA), Abbotsford, BC - V2S 7P6, 8.820 s Aug 30 2024 MiTek Industries, Inc. Thu Sep 12 02:48:00 2024 Page 1

ID:hFyjDMxrTsEK_kgkR0vWWVzFlgc-JYnhem_UP53KkPQQFdsplqmS0Q1WTXWfVkuOU7EyeVrD

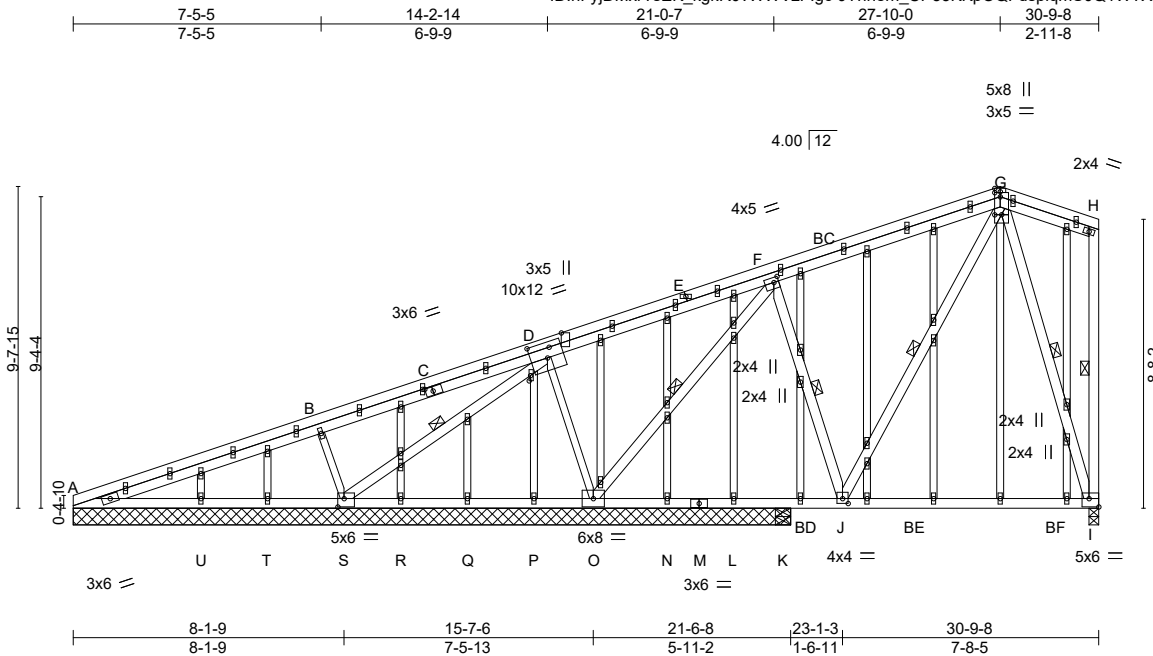

Scale = 1:69.2

Plate Offsets (X,Y)-- [C:0-2-11,0-1-8], [D:0-6-0,0-5-8], [D:0-1-14,0-0-8], [D:0-5-3,Edge], [F:0-1-12,0-1-12], [G:0-1-8,0-2-0], [G:0-2-8,0-0-1], [G:0-2-0,Edge], [I:Edge,0-3-0], [J:0-2-0,0-1-12], [S:0-2-4,0-3-0]

LOADING (psf)	SPACING-	CSI.	DEFL.	in (loc)	l/defl	L/d	PLATES	GRIP
TCLL 25.0 (Roof Snow=25.0)	2-0-0	TC 0.79	Vert(LL) -0.17	I-J	>679	360	MT20	197/144
TCDL 12.0	Plate Grip DOL 1.15	BC 0.61	Vert(CT) -0.26	I-J	>427	240		
BCLL 0.0 *	Lumber DOL 1.15	WB 0.86	Horz(CT) -0.02	N	n/a	n/a		
BCDL 10.0	Rep Stress Incr YES	Matrix-MS	Wind(LL) 0.03	I-J	>999	240	Weight: 223 lb	FT = 20%
	Code IBC2018/TPI2014							

LUMBER-

TOP CHORD 2x4 SPF No.2
 BOT CHORD 2x4 SPF No.2
 WEBS 2x4 SPF No.2 *Except*
 B-S,D-O: 2x3 SPF No.2
 OTHERS 2x3 SPF No.2

BRACING-

TOP CHORD Structural wood sheathing directly applied or 2-2-0 oc purlins, except end verticals.
 BOT CHORD Rigid ceiling directly applied or 3-10-7 oc bracing.
 WEBS 1 Row at midpt D-S, F-O, F-J, G-J, H-I, G-I

REACTIONS.

All bearings 21-6-8 except (jt=length) I=0-3-8, K=0-5-8.
 (lb) - Max Horz A=298(LC 38)
 Max Uplift All uplift 100 lb or less at joint(s) T, U except S=-1694(LC 31), O=-1065(LC 31), I=-1279(LC 32), A=-840(LC 31), K=-116(LC 18)
 Max Grav All reactions 250 lb or less at joint(s) L, N, P, Q, R, T, U, K except S=1772(LC 52), O=1663(LC 28), I=1646(LC 25), A=920(LC 52), A=276(LC 1)

FORCES. (lb) - Max. Comp./Max. Ten. - All forces 250 (lb) or less except when shown.

TOP CHORD A-B=-2591/2424, B-D=-957/932, D-F=-1614/1540, F-G=-1708/1570, G-H=-750/788
 BOT CHORD A-U=-2089/1978, T-U=-1312/1201, S-T=-547/515, R-S=-1794/1683, Q-R=-1210/1101, P-Q=-524/415, O-P=-996/887, N-O=-746/884, L-N=-873/979, K-L=-1381/1447, J-K=-1381/1447, I-J=-450/468
 WEBS B-S=-571/218, D-S=-2554/2513, D-O=-933/949, F-O=-2375/2163, F-J=-1136/1263, G-J=-1255/1387, G-I=-1543/1354

NOTES-

- 1) Wind: ASCE 7-16; Vult=115mph (3-second gust) Vasd=91mph; TCCL=4.2psf; BCDL=5.0psf; h=30ft; Ke=1.00; Cat. II; Exp B; Enclosed; MWFRS (envelope) gable end zone; cantilever left and right exposed ; end vertical left and right exposed; Lumber DOL=1.33 plate grip DOL=1.33
- 2) Truss designed for wind loads in the plane of the truss only. For studs exposed to wind (normal to the face), see Standard Industry Gable End Details as applicable, or consult qualified building designer as per ANSI/TPI 1.
- 3) TCLL: ASCE 7-16; Pf=25.0 psf (Lum DOL = 1.15 Plate DOL = 1.15); Is=1.0; Rough Cat B; Partially Exp.; Ce=1.0; Cs=1.00; Ct=1.10
- 4) Unbalanced snow loads have been considered for this design.
- 5) All plates are 1.5x4 MT20 unless otherwise indicated.
- 6) Gable studs spaced at 2-0-0 oc.
- 7) This truss has been designed for a 10.0 psf bottom chord live load nonconcurrent with any other live loads.
- 8) * This truss has been designed for a live load of 20.0psf on the bottom chord in all areas where a rectangle 3-6-0 tall by 2-0-0 wide will fit between the bottom chord and any other members, with BCDL = 10.0psf.
- 9) Provide mechanical connection (by others) of truss to bearing plate capable of withstanding 100 lb uplift at joint(s) T, U except (jt=lb) S=1694, O=1065, I=1279, A=840, K=116, A=840.
- 10) This truss is designed in accordance with the 2018 International Building Code section 2306.1 and referenced standard ANSI/TPI 1.
- 11) This truss has been designed for a total drag load of 240 plf. Lumber DOL=(1.33) Plate grip DOL=(1.33) Connect truss to resist



September 12, 2024

WARNING - Verify design parameters and READ NOTES ON THIS AND INCLUDED MITEK REFERENCE PAGE MII-7473 rev. 6/30/2020 BEFORE USE.

Design valid for use only with MiTek® connectors. This design is based only upon parameters shown, and is for an individual building component, not a truss system. Before use, the building designer must verify the applicability of design parameters and properly incorporate this design into the overall building design. Bracing indicated is to prevent buckling of individual truss web and/or chord members only. Additional temporary and permanent bracing is always required for stability and to prevent collapse with possible personal injury and property damage. For general guidance regarding the fabrication, storage, delivery, erection and bracing of trusses and truss systems, see ANSI/TPI1 Quality Criteria, DSB-89 and BCSI Building Component Safety Information available from Truss Plate Institute, 2670 Crain Highway, Suite 203 Waldorf, MD 20601



Job	Truss	Truss Type	Qty	Ply	Buildings A-H
N0653A	A5	GABLE	5	1	U1530823

Alliance Truss (CA), Abbotsford, BC - V2S 7P6,

8.820 s Aug 30 2024 MiTek Industries, Inc. Thu Sep 12 02:48:00 2024 Page 2

ID:hFyjDMxrTsEK_kgkR0vWWVzFlgc-JYnhem_UP53KKpOQFdspIqmS0Q1WTXWfVkuOU7EyeVrD

NOTES-

- 12) No notches allowed in overhang and 0 from left end and 0 from right end or 12" along rake from scarf, whichever is larger. Minimum 1.5x4 tie plates required at 2-0-0 o.c. maximum between the stacking chords. For edge-wise notching, provide at least one tie plate between each notch.

WARNING - Verify design parameters and READ NOTES ON THIS AND INCLUDED MITEK REFERENCE PAGE MII-7473 rev. 6/30/2020 BEFORE USE.

Design valid for use only with MiTek® connectors. This design is based only upon parameters shown, and is for an individual building component, not a truss system. Before use, the building designer must verify the applicability of design parameters and properly incorporate this design into the overall building design. Bracing indicated is to prevent buckling of individual truss web and/or chord members only. Additional temporary and permanent bracing is always required for stability and to prevent collapse with possible personal injury and property damage. For general guidance regarding the fabrication, storage, delivery, erection and bracing of trusses and truss systems, see

Safety Information available from Truss Plate Institute, 2670 Crain Highway, Suite 203 Waldorf, MD 20601

ANSI/TPI1 Quality Criteria, DSB-89 and BCSI Building Component



240 Stirling Crescent
Bradford, ON. L3Z 4L5

Job	Truss	Truss Type	Qty	Ply	Buildings A-H	U1530824
N0653A	A6	Common	2	1		

Alliance Truss (CA), Abbotsford, BC - V2S 7P6, 8.820 s Aug 30 2024 MiTek Industries, Inc. Thu Sep 12 02:48:01 2024 Page 1

ID:hFyjDMxrTsEK_kgkR0vWWVzFlgc-nlL3s6?6A0BBByzdoLN2l1JdLqOfCy0p7O72fgyeVrC

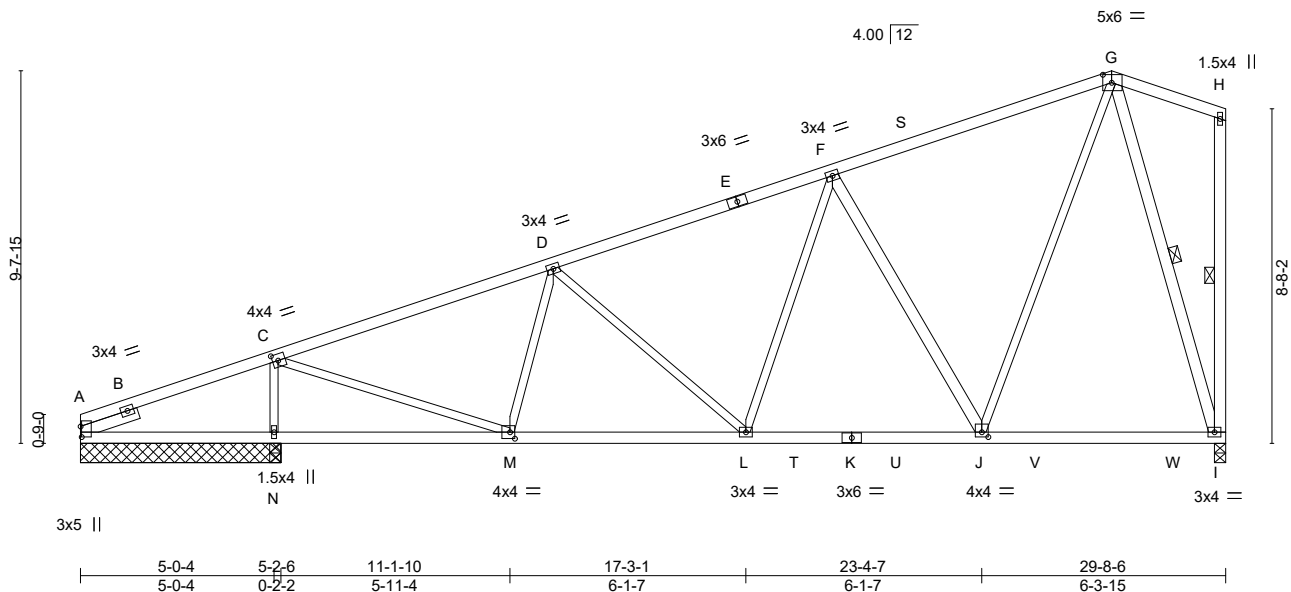

Plate Offsets (X,Y)-- [A:0-3-5,0-0-6], [C:0-1-12,0-2-0], [G:0-2-12,0-2-8], [J:0-2-0,0-1-8], [M:0-1-8,0-2-0]

LOADING (psf)	SPACING-	CSI.	DEFL.	PLATES	GRIP
TCLL 25.0 (Roof Snow=25.0)	2-0-0 Plate Grip DOL 1.15	TC 0.81	in (loc) l/defl L/d	MT20	197/144
TCDL 12.0	Lumber DOL 1.15	BC 0.55	Vert(LL) -0.08 I-J >999 360		
BCLL 0.0 *	Rep Stress Incr YES	WB 0.97	Vert(CT) -0.14 L-M >999 240		
BCDL 10.0	Code IBC2018/TPI2014	Matrix-MS	Horz(CT) 0.03 I n/a n/a		
			Wind(LL) 0.04 L-M >999 240	Weight: 130 lb	FT = 20%

LUMBER-

TOP CHORD 2x4 SPF No.2
 BOT CHORD 2x4 SPF No.2
 WEBS 2x3 SPF No.2 *Except*
 F-J,H-I,G-I: 2x4 SPF No.2
 SLIDER Left 2x4 SPF No.2 1-7-0

BRACING-

TOP CHORD Structural wood sheathing directly applied or 4-2-4 oc purlins, except end verticals.
 BOT CHORD Rigid ceiling directly applied or 10-0-0 oc bracing.
 WEBS 1 Row at midpt H-I, G-I

REACTIONS.

All bearings 5-2-6 except (jt=length) I=0-3-8.
 (lb) - Max Horz A=253(LC 10)
 Max Uplift All uplift 100 lb or less at joint(s) except N=186(LC 6), I=156(LC 6)
 Max Grav All reactions 250 lb or less at joint(s) A, A except N=1548(LC 3), N=1463(LC 1), I=1241(LC 3)

FORCES. (lb) - Max. Comp./Max. Ten. - All forces 250 (lb) or less except when shown.

TOP CHORD C-D=-1470/90, D-F=-1363/113, F-G=-834/90
 BOT CHORD L-M=-264/1390, J-L=-186/1109, I-J=-52/342
 WEBS C-N=-1344/232, C-M=-94/1385, D-M=-327/100, D-L=-271/101, F-L=-10/409, F-J=-859/198,
 G-J=-1111/1073, G-I=-1171/186

NOTES-

- 1) Wind: ASCE 7-16; Vult=115mph (3-second gust) Vasd=91mph; TCDL=4.2psf; BCDL=5.0psf; h=30ft; Ke=1.00; Cat. II; Exp B; Enclosed; MWFRS (envelope) gable end zone; cantilever left exposed ; end vertical left exposed; Lumber DOL=1.33 plate grip DOL=1.33
- 2) TCLL: ASCE 7-16; Pf=25.0 psf (Lum DOL = 1.15 Plate DOL = 1.15); Is=1.0; Rough Cat B; Partially Exp.; Ce=1.0; Cs=1.00; Ct=1.10
- 3) Unbalanced snow loads have been considered for this design.
- 4) This truss has been designed for a 10.0 psf bottom chord live load nonconcurrent with any other live loads.
- 5) * This truss has been designed for a live load of 20.0psf on the bottom chord in all areas where a rectangle 3-6-0 tall by 2-0-0 wide will fit between the bottom chord and any other members, with BCDL = 10.0psf.
- 6) Provide mechanical connection (by others) of truss to bearing plate capable of withstanding 186 lb uplift at joint N and 156 lb uplift at joint I.
- 7) This truss is designed in accordance with the 2018 International Building Code section 2306.1 and referenced standard ANSI/TPI 1.



September 12, 2024

WARNING - Verify design parameters and READ NOTES ON THIS AND INCLUDED MITEK REFERENCE PAGE MII-7473 rev. 6/30/2020 BEFORE USE.

Design valid for use only with MiTek® connectors. This design is based only upon parameters shown, and is for an individual building component, not a truss system. Before use, the building designer must verify the applicability of design parameters and properly incorporate this design into the overall building design. Bracing indicated is to prevent buckling of individual truss web and/or chord members only. Additional temporary and permanent bracing is always required for stability and to prevent collapse with possible personal injury and property damage. For general guidance regarding the fabrication, storage, delivery, erection and bracing of trusses and truss systems, see

Safety Information available from Truss Plate Institute, 2670 Crain Highway, Suite 203 Waldorf, MD 20601



240 Stirling Crescent
 Bradford, ON. L3Z 4L5

Job	Truss	Truss Type	Qty	Ply	Buildings A-H	U1530825
N0653A	A7	Scissor	14	1		

Alliance Truss (CA), Abbotsford, BC - V2S 7P6, 8.820 s Aug 30 2024 MiTek Industries, Inc. Thu Sep 12 02:48:01 2024 Page 1

ID:hFyjDMxrTsEK_kgkR0vWWWVzFlgc-nL3s6?6A0BByzdoLN211JfSqMGC1pp7072fgyeVrC

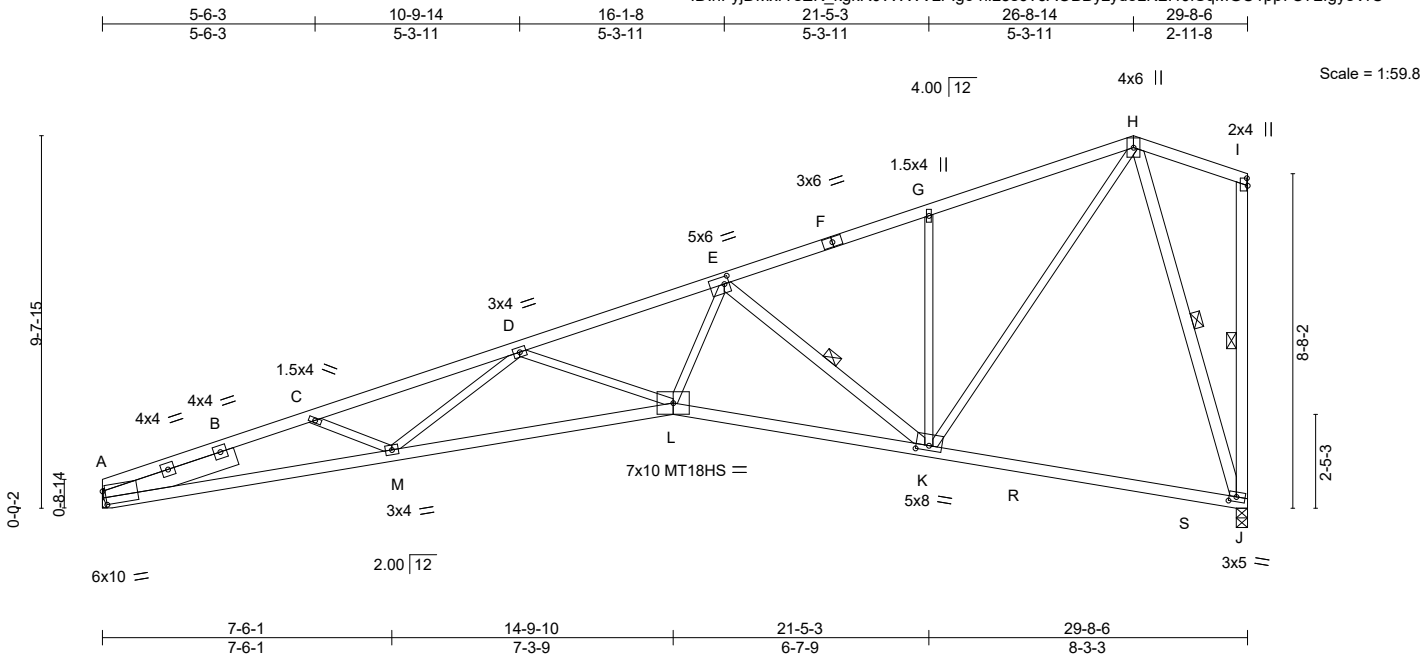

Plate Offsets (X,Y)-- [A:0-0-12,0-4-6], [E:0-1-8,0-2-4], [I:0-2-5,0-0-4], [J:0-2-4,0-1-8], [K:0-4-0,0-1-8]

LOADING (psf)	SPACING-	CSI.	DEFL.	PLATES	GRIP
TCLL 25.0 (Roof Snow=25.0)	2-0-0 Plate Grip DOL 1.15	TC 0.68	in (loc) l/defl L/d	MT20	197/144
TCDL 12.0	Lumber DOL 1.15	BC 0.70	Vert(LL) -0.41 L-M >869 360	MT18HS	197/144
BCLL 0.0 *	Rep Stress Incr YES	WB 0.66	Vert(CT) -0.75 L-M >470 240		
BCDL 10.0	Code IBC2018/TPI2014	Matrix-MS	Horz(CT) 0.31 J n/a n/a		
			Wind(LL) 0.21 L-M >999 240	Weight: 128 lb	FT = 20%

LUMBER-

TOP CHORD 2x4 SPF No.2 *Except*
A-F: 2x4 SPF 2100F 1.8E
BOT CHORD 2x4 SPF 2100F 1.8E
WEBS 2x3 SPF No.2 *Except*
E-K,I-J,H-J: 2x4 SPF No.2
SLIDER Left 2x6 SPF No.2 3-7-10

BRACING-

TOP CHORD Structural wood sheathing directly applied or 2-6-7 oc purlins, except end verticals.
BOT CHORD Rigid ceiling directly applied or 9-7-6 oc bracing.
WEBS 1 Row at midpt E-K, I-J, H-J

REACTIONS.

(size) A=Mechanical, J=0-3-8
Max Horz A=264(LC 9)
Max Uplift A=-154(LC 6), J=-169(LC 6)
Max Grav A=1448(LC 3), J=1491(LC 3)

FORCES. (lb) - Max. Comp./Max. Ten. - All forces 250 (lb) or less except when shown.

TOP CHORD A-C=-4837/607, C-D=-4865/548, D-E=-3946/460, E-G=-1611/201, G-H=-1637/262
BOT CHORD A-M=-663/4569, L-M=-610/4472, K-L=-362/3067, J-K=-98/459
WEBS D-M=0/324, D-L=-789/191, E-L=-183/1864, E-K=-2001/306, G-K=-501/146, H-K=-243/1928, H-J=-1429/161

NOTES-

- Wind: ASCE 7-16; Vult=115mph (3-second gust) Vasd=91mph; TCDL=4.2psf; BCCL=5.0psf; h=30ft; Ke=1.00; Cat. II; Exp B; Enclosed; MWFRS (envelope) gable end zone; cantilever left and right exposed; end vertical left and right exposed; Lumber DOL=1.33 plate grip DOL=1.33
- TCLL: ASCE 7-16; Pf=25.0 psf (Lum DOL = 1.15 Plate DOL = 1.15); Is=1.0; Rough Cat B; Partially Exp.; Ce=1.0; Cs=1.00; Ct=1.10
- Unbalanced snow loads have been considered for this design.
- All plates are MT20 plates unless otherwise indicated.
- This truss has been designed for a 10.0 psf bottom chord live load nonconcurrent with any other live loads.
- * This truss has been designed for a live load of 20.0psf on the bottom chord in all areas where a rectangle 3-6-0 tall by 2-0-0 wide will fit between the bottom chord and any other members, with BCCL = 10.0psf.
- Refer to girder(s) for truss to truss connections.
- Bearing at joint(s) J considers parallel to grain value using ANSI/TPI 1 angle to grain formula. Building designer should verify capacity of bearing surface.
- Provide mechanical connection (by others) of truss to bearing plate capable of withstanding 154 lb uplift at joint A and 169 lb uplift at joint J.
- This truss is designed in accordance with the 2018 International Building Code section 2306.1 and referenced standard ANSI/TPI 1.



September 12, 2024

WARNING - Verify design parameters and READ NOTES ON THIS AND INCLUDED MITEK REFERENCE PAGE MII-7473 rev. 6/30/2020 BEFORE USE.

Design valid for use only with MiTek® connectors. This design is based only upon parameters shown, and is for an individual building component, not a truss system. Before use, the building designer must verify the applicability of design parameters and properly incorporate this design into the overall building design. Bracing indicated is to prevent buckling of individual truss web and/or chord members only. Additional temporary and permanent bracing is always required for stability and to prevent collapse with possible personal injury and property damage. For general guidance regarding the fabrication, storage, delivery, erection and bracing of trusses and truss systems, see ANSI/TPI1 Quality Criteria, DSB-89 and BCSI Building Component Safety Information available from Truss Plate Institute, 2670 Crain Highway, Suite 203 Waldorf, MD 20601



240 Stirling Crescent
Bradford, ON. L3Z 4L5

Job	Truss	Truss Type	Qty	Ply	Buildings A-H	U1530826
N0653A	A8	Common	2	1		

Alliance Truss (CA), Abbotsford, BC - V2S 7P6, 8.820 s Aug 30 2024 MiTek Industries, Inc. Thu Sep 12 02:48:02 2024 Page 1

ID:hFyjDMxrTsEK_kgkR0vWWVzFfgc-GxvS3S0kxiJ2Z6XpM2vHqFrpmEhaxVWym2tbB7yeVrB

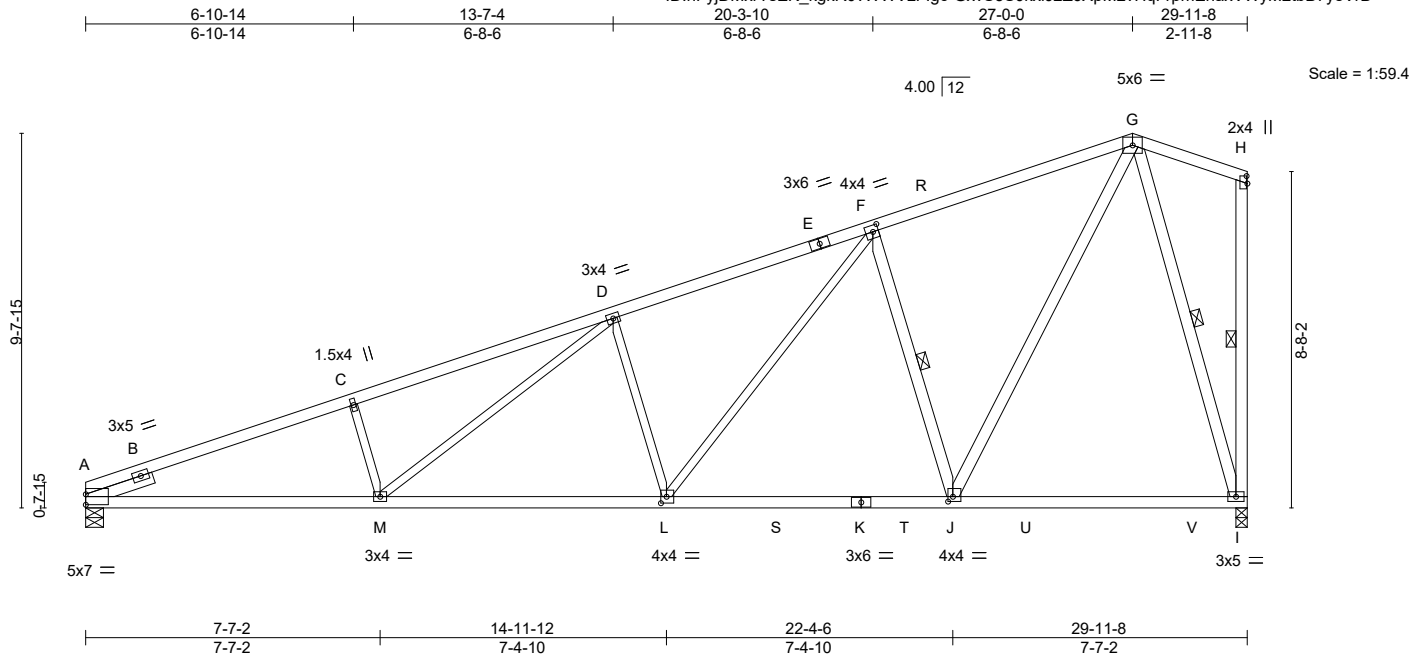

Plate Offsets (X,Y)-- [A:0-0-0,0-3-4], [F:0-1-12,0-2-0], [H:0-2-5,0-0-4], [J:0-1-8,0-1-8], [L:0-1-12,0-2-0]

LOADING (psf)	SPACING-	2-0-0	CSI.	DEFL.	in (loc)	l/defl	L/d	PLATES	GRIP
TCLL 25.0 (Roof Snow=25.0)	Plate Grip DOL 1.15		TC 0.71	Vert(LL) -0.21	L-M	>999	360	MT20	197/144
TCDL 12.0	Lumber DOL 1.15		BC 0.76	Vert(CT) -0.39	L-M	>914	240		
BCLL 0.0 *	Rep Stress Incr YES		WB 0.63	Horz(CT) 0.07	I	n/a	n/a		
BCDL 10.0	Code IBC2018/TPI2014		Matrix-MS	Wind(LL) 0.10	L-M	>999	240	Weight: 131 lb	FT = 20%

LUMBER-

TOP CHORD 2x4 SPF No.2 *Except*
A-E: 2x4 SPF 2100F 1.8E
BOT CHORD 2x4 SPF No.2 *Except*
A-K: 2x4 SPF 2100F 1.8E
WEBS 2x4 SPF No.2 *Except*
C-M,D-M,D-L,F-L: 2x3 SPF No.2
SLIDER Left 2x4 SPF No.2 1-9-12

BRACING-

TOP CHORD Structural wood sheathing directly applied or 3-4-2 oc purlins, except end verticals.
BOT CHORD Rigid ceiling directly applied or 10-0-0 oc bracing.
WEBS 1 Row at midpt F-J, H-I, G-I

REACTIONS.

(size) A=0-5-8, I=0-3-8
Max Horz A=264(LC 9)
Max Uplift A=-155(LC 6), I=-170(LC 6)
Max Grav A=1476(LC 3), I=1532(LC 3)

FORCES. (lb) - Max. Comp./Max. Ten. - All forces 250 (lb) or less except when shown.

TOP CHORD A-C=-3225/352, C-D=-3137/378, D-F=-2323/303, F-G=-1277/209
BOT CHORD A-M=-412/2999, L-M=-286/2327, J-L=-143/1444, I-J=-88/422
WEBS C-M=-377/150, D-M=-111/766, D-L=-749/200, F-L=-149/1181, F-J=-1177/257, G-J=-193/1599, G-I=-1437/167

NOTES-

- 1) Wind: ASCE 7-16; Vult=115mph (3-second gust) Vasd=91mph; TCDL=4.2psf; BCDL=5.0psf; h=30ft; Ke=1.00; Cat. II; Exp B; Enclosed; MWFRS (envelope) gable end zone; cantilever left and right exposed ; end vertical left and right exposed; Lumber DOL=1.33 plate grip DOL=1.33
- 2) TCLL: ASCE 7-16; Pf=25.0 psf (Lum DOL = 1.15 Plate DOL = 1.15); Is=1.0; Rough Cat B; Partially Exp.; Ce=1.0; Cs=1.00; Ct=1.10
- 3) Unbalanced snow loads have been considered for this design.
- 4) This truss has been designed for a 10.0 psf bottom chord live load nonconcurrent with any other live loads.
- 5) * This truss has been designed for a live load of 20.0psf on the bottom chord in all areas where a rectangle 3-6-0 tall by 2-0-0 wide will fit between the bottom chord and any other members, with BCDL = 10.0psf.
- 6) Provide mechanical connection (by others) of truss to bearing plate capable of withstanding 155 lb uplift at joint A and 170 lb uplift at joint I.
- 7) This truss is designed in accordance with the 2018 International Building Code section 2306.1 and referenced standard ANSI/TPI 1.



September 12, 2024

WARNING - Verify design parameters and READ NOTES ON THIS AND INCLUDED MITEK REFERENCE PAGE MII-7473 rev. 6/30/2020 BEFORE USE.

Design valid for use only with MiTek® connectors. This design is based only upon parameters shown, and is for an individual building component, not a truss system. Before use, the building designer must verify the applicability of design parameters and properly incorporate this design into the overall building design. Bracing indicated is to prevent buckling of individual truss web and/or chord members only. Additional temporary and permanent bracing is always required for stability and to prevent collapse with possible personal injury and property damage. For general guidance regarding the fabrication, storage, delivery, erection and bracing of trusses and truss systems, see

ANSI/TPI1 Quality Criteria, DSB-89 and BCSI Building Component Safety Information available from Truss Plate Institute, 2670 Crain Highway, Suite 203 Waldorf, MD 20601



240 Stirling Crescent
Bradford, ON. L3Z 4L5

Job N0653A	Truss A10	Truss Type GABLE	Qty 2	Ply 1	Buildings A-H Job Reference (optional)	U1530828
---------------	--------------	---------------------	----------	----------	---	----------

Alliance Truss (CA), Abbotsford, BC - V2S 7P6,

8.820 s Aug 30 2024 MiTek Industries, Inc. Thu Sep 12 02:47:47 2024 Page 1
ID:hFyjDMxrTsEK_kgkR0vWWWvzF1gc-C2VnwKqKT5RAGpuw_P7mj4jBPBc3wjtlvDki9UyeVrQ

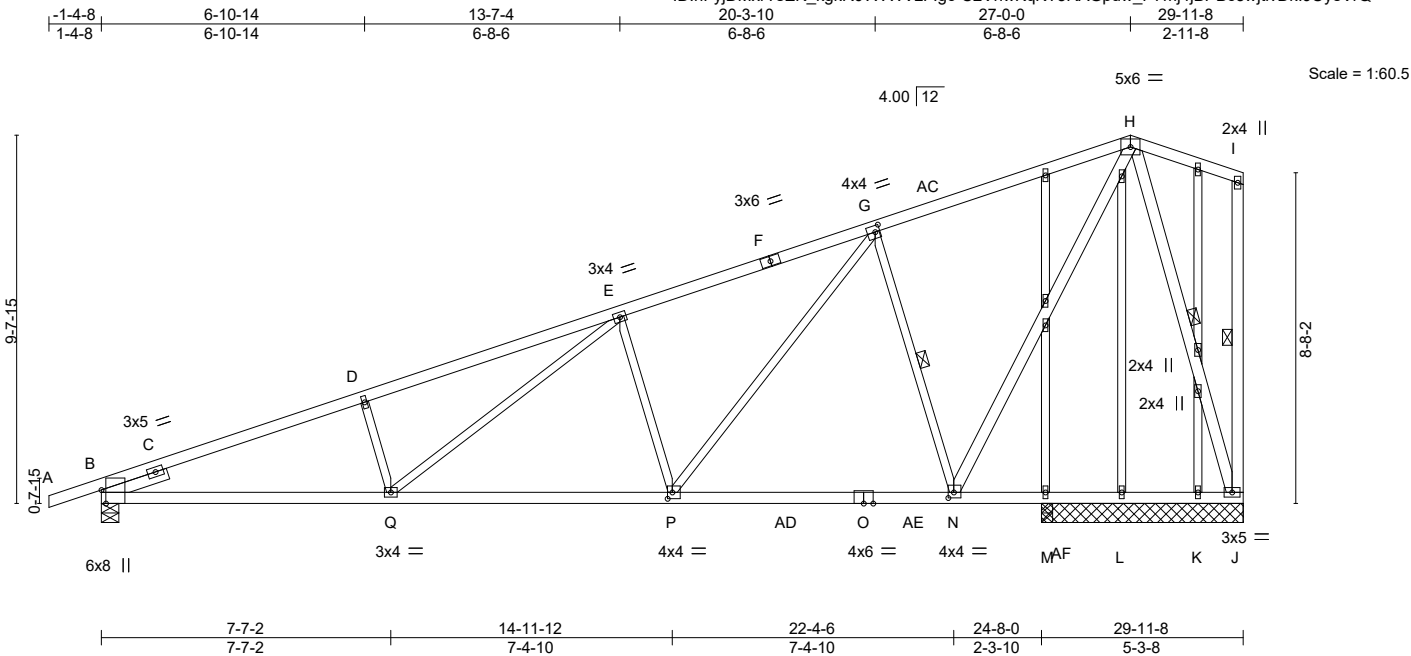

Plate Offsets (X,Y)-- [B:0-4-4,Edge], [G:0-1-8,0-2-0], [N:0-1-12,0-1-12], [P:0-1-8,0-2-0]

LOADING (psf)	SPACING-	CSI.	DEFL.	PLATES	GRIP
TCLL 25.0 (Roof Snow=25.0)	2-0-0 Plate Grip DOL 1.15	TC 0.97	in (loc) l/defl L/d	MT20	197/144
TCDL 12.0	Lumber DOL 1.15	BC 0.63	Vert(LL) -0.22 N-P >999 360		
BCLL 0.0 *	Rep Stress Incr YES	WB 0.63	Vert(CT) -0.40 P-Q >751 240		
BCDL 10.0	Code IBC2018/TPI2014	Matrix-MS	Horz(CT) 0.06 J n/a n/a		
			Wind(LL) 0.11 P-Q >999 240	Weight: 151 lb	FT = 20%

LUMBER-

TOP CHORD 2x4 SPF No.2
 BOT CHORD 2x4 SPF No.2 *Except*
 B-O: 2x4 SPF 2100F 1.8E
 WEBS 2x3 SPF No.2 *Except*
 H-N,I-J,H-J: 2x4 SPF No.2
 OTHERS 2x3 SPF No.2
 SLIDER Left 2x4 SPF No.2 1-9-12

BRACING-

TOP CHORD Structural wood sheathing directly applied, except end verticals.
 BOT CHORD Rigid ceiling directly applied or 10-0-0 oc bracing.
 WEBS 1 Row at midpt G-N, I-J, H-J

REACTIONS.

All bearings 5-3-8 except (jt=length) B=0-5-8, M=0-3-8, M=0-3-8.
 (lb) - Max Horz B=272(LC 9)
 Max Uplift All uplift 100 lb or less at joint(s) K, M except B=198(LC 6), J=183(LC 7), L=145(LC 17)
 Max Grav All reactions 250 lb or less at joint(s) L, K except B=1513(LC 3), J=1198(LC 2), M=309(LC 3), M=291(LC 1)

FORCES. (lb) - Max. Comp./Max. Ten. - All forces 250 (lb) or less except when shown.

TOP CHORD B-D=-3068/336, D-E=-2980/361, E-G=-2183/293, G-H=-1099/201
 BOT CHORD B-Q=-401/2851, P-Q=-278/2193, N-P=-147/1283, M-N=-94/364, L-M=-94/364, K-L=-94/364, J-K=-94/364
 WEBS D-Q=-381/149, E-Q=-107/747, E-P=-740/199, G-P=-148/1228, G-N=-1196/257, H-N=-184/1349, H-J=-1272/163

NOTES-

- 1) Wind: ASCE 7-16; Vult=115mph (3-second gust) Vasd=91mph; TCDL=4.2psf; BCDL=5.0psf; h=30ft; Ke=1.00; Cat. II; Exp B; Enclosed; MWFRS (envelope) gable end zone; cantilever left and right exposed; end vertical left and right exposed; Lumber DOL=1.33 plate grip DOL=1.33
- 2) Truss designed for wind loads in the plane of the truss only. For studs exposed to wind (normal to the face), see Standard Industry Gable End Details as applicable, or consult qualified building designer as per ANSI/TPI 1.
- 3) TCLL: ASCE 7-16; Pf=25.0 psf (Lum DOL = 1.15 Plate DOL = 1.15); Is=1.0; Rough Cat B; Partially Exp.; Ce=1.0; Cs=1.00; Ct=1.10
- 4) Unbalanced snow loads have been considered for this design.
- 5) This truss has been designed for greater of min roof live load of 20.0 psf or 2.00 times flat roof load of 25.0 psf on overhangs non-concurrent with other live loads.
- 6) All plates are 1.5x4 MT20 unless otherwise indicated.
- 7) Gable studs spaced at 2-0-0 oc.
- 8) This truss has been designed for a 10.0 psf bottom chord live load nonconcurrent with any other live loads.
- 9) * This truss has been designed for a live load of 20.0psf on the bottom chord in all areas where a rectangle 3-6-0 tall by 2-0-0 wide will fit between the bottom chord and any other members, with BCDL = 10.0psf.
- 10) Provide mechanical connection (by others) of truss to bearing plate capable of withstanding 100 lb uplift at joint(s) K, M except (jt=lb) B=198, J=183, L=145.
- 11) This truss is designed in accordance with the 2018 International Building Code section 2306.1 and referenced standard ANSI/TPI 1.



September 12, 2024

WARNING - Verify design parameters and READ NOTES ON THIS AND INCLUDED MITEK REFERENCE PAGE MII-7473 rev. 6/30/2020 BEFORE USE.

Design valid for use only with MiTek® connectors. This design is based only upon parameters shown, and is for an individual building component, not a truss system. Before use, the building designer must verify the applicability of design parameters and properly incorporate this design into the overall building design. Bracing indicated is to prevent buckling of individual truss web and/or chord members only. Additional temporary and permanent bracing is always required for stability and to prevent collapse with possible personal injury and property damage. For general guidance regarding the fabrication, storage, delivery, erection and bracing of trusses and truss systems, see **ANSI/TPI1 Quality Criteria, DSB-89 and BCSI Building Component Safety Information** available from Truss Plate Institute, 2670 Crain Highway, Suite 203 Waldorf, MD 20601



240 Stirling Crescent
 Bradford, ON. L3Z 4L5

Job	Truss	Truss Type	Qty	Ply	Buildings A-H	
N0653A	A11	GABLE	2	1		U1530829
Alliance Truss (CA), Abbotsford, BC - V2S 7P6,						8.820 s Aug 30 2024 MiTek Industries, Inc. Thu Sep 12 02:47:48 2024 Page 1
						ID:hFyjDMxrTsEK_kgkR0vWWWzFlgc-gF397gryEPZ1uzT7Y6f?GIGQmbr9f89u8tUshyevrP

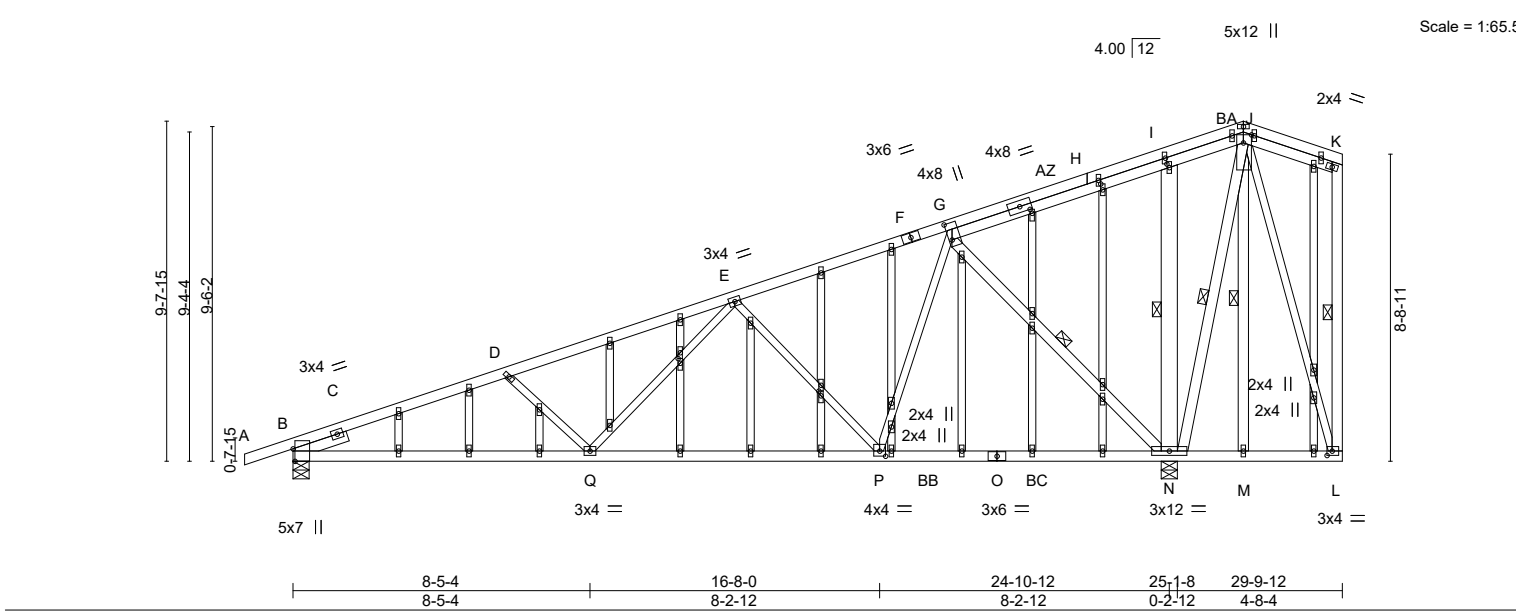
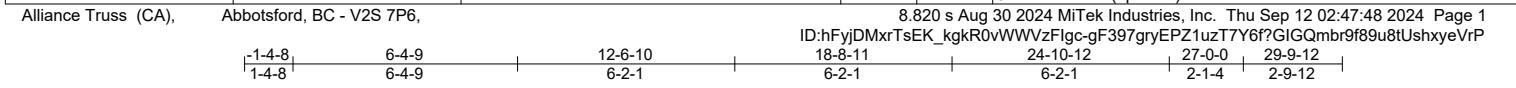

Plate Offsets (X,Y)-- [B:0-4-4,Edge], [G:0-5-12,0-1-0], [I:0-2-0,0-0-8], [J:0-2-12,Edge], [L:0-1-12,0-1-8], [P:0-2-0,0-1-12], [R:0-2-0,0-0-11], [U:0-1-6,0-0-12], [AE:0-1-10,0-0-12], [AH:0-1-10,0-0-12]

LOADING (psf)	SPACING-	CSI.	DEFL.	in (loc)	l/defl	L/d	PLATES	GRIP
TCLL 25.0 (Roof Snow=25.0)	2-0-0	TC 0.74	Vert(LL) -0.16	P-Q	>999	360	MT20	197/144
TCDL 12.0	Lumber DOL 1.15	BC 0.96	Vert(CT) -0.31	P-Q	>949	240		
BCLL 0.0 *	Rep Stress Incr YES	WB 0.75	Horz(CT) 0.06	N	n/a	n/a		
BCDL 10.0	Code IBC2018/TPI2014	Matrix-MS	Wind(LL) 0.08	P-Q	>999	240	Weight: 208 lb	FT = 20%

LUMBER-	BRACING-
TOP CHORD 2x4 SPF No.2	TOP CHORD Structural wood sheathing directly applied or 2-5-1 oc purlins, except end verticals.
BOT CHORD 2x4 SPF No.2	BOT CHORD Rigid ceiling directly applied or 2-2-0 oc bracing.
WEBS 2x3 SPF No.2 *Except* G-N,J-N,K-L: 2x4 SPF No.2, I-N: 2x6 SPF No.2	WEBS 1 Row at midpt G-N, I-N, J-N, K-L, J-M
OTHERS 2x3 SPF No.2 *Except* J-M: 2x4 SPF No.2	
SLIDER Left 2x4 SPF No.2 1-7-4	

REACTIONS. (size) B=0-5-8, N=0-5-8
 Max Horz B=265(LC 9)
 Max Uplift B=-168(LC 6), N=-203(LC 6)
 Max Grav B=1263(LC 3), N=1742(LC 3)

FORCES. (lb) - Max. Comp./Max. Ten. - All forces 250 (lb) or less except when shown.
 TOP CHORD B-D=-2427/278, D-E=-2187/227, E-G=-1200/154
 BOT CHORD B-Q=-347/2252, P-Q=-223/1591, N-P=-84/804
 WEBS D-Q=-396/149, E-Q=-26/641, E-P=-793/183, G-P=-55/941, G-N=-1251/212, I-N=-475/123, J-N=-360/115

- NOTES-**
- Wind: ASCE 7-16; Vult=115mph (3-second gust) Vasd=91mph; TCDL=4.2psf; BCDL=5.0psf; h=30ft; Ke=1.00; Cat. II; Exp B; Enclosed; MWFRS (envelope) gable end zone; cantilever left and right exposed ; end vertical left and right exposed; Lumber DOL=1.33 plate grip DOL=1.33
 - Truss designed for wind loads in the plane of the truss only. For studs exposed to wind (normal to the face), see Standard Industry Gable End Details as applicable, or consult qualified building designer as per ANSI/TPI 1.
 - TCLL: ASCE 7-16; Pf=25.0 psf (Lum DOL = 1.15 Plate DOL = 1.15); Is=1.0; Rough Cat B; Partially Exp.; Ce=1.0; Cs=1.00; Ct=1.10
 - Unbalanced snow loads have been considered for this design.
 - This truss has been designed for greater of min roof live load of 20.0 psf or 2.00 times flat roof load of 25.0 psf on overhangs non-concurrent with other live loads.
 - All plates are 1.5x4 MT20 unless otherwise indicated.
 - Gable studs spaced at 2-0-0 oc.
 - This truss has been designed for a 10.0 psf bottom chord live load nonconcurrent with any other live loads.
 - * This truss has been designed for a live load of 20.0psf on the bottom chord in all areas where a rectangle 3-6-0 tall by 2-0-0 wide will fit between the bottom chord and any other members, with BCDL = 10.0psf.
 - Provide mechanical connection (by others) of truss to bearing plate capable of withstanding 100 lb uplift at joint(s) except (jt=lb) B=168, N=203.
 - This truss is designed in accordance with the 2018 International Building Code section 2306.1 and referenced standard ANSI/TPI 1.



September 12, 2024

Continued on page 2

WARNING - Verify design parameters and READ NOTES ON THIS AND INCLUDED MITEK REFERENCE PAGE MII-7473 rev. 6/30/2020 BEFORE USE.
 Design valid for use only with MiTek® connectors. This design is based only upon parameters shown, and is for an individual building component, not a truss system. Before use, the building designer must verify the applicability of design parameters and properly incorporate this design into the overall building design. Bracing indicated is to prevent buckling of individual truss web and/or chord members only. Additional temporary and permanent bracing is always required for stability and to prevent collapse with possible personal injury and property damage. For general guidance regarding the fabrication, storage, delivery, erection and bracing of trusses and truss systems, see **ANSI/TPI1 Quality Criteria, DSB-89 and BCSI Building Component Safety Information** available from Truss Plate Institute, 2670 Crain Highway, Suite 203 Waldorf, MD 20601



Job	Truss	Truss Type	Qty	Ply	Buildings A-H
N0653A	A11	GABLE	2	1	U1530829

Alliance Truss (CA), Abbotsford, BC - V2S 7P6,

8.820 s Aug 30 2024 MiTek Industries, Inc. Thu Sep 12 02:47:48 2024 Page 2
 ID:hFyjDMxrTsEK_kgkR0vWWWzF1gc-gF397gryEPZ1uzT7Y6f?GIGQmbr9f89u8tUshxyeVrP

NOTES-

- 12) No notches allowed in overhang and 200/100 from left end and 0 from right end or 12" along rake from scarf, whichever is larger. Minimum 1.5x4 tie plates required at 2-0-0 o.c. maximum between the stacking chords. For edge-wise notching, provide at least one tie plate between each notch.



WARNING - Verify design parameters and READ NOTES ON THIS AND INCLUDED MITEK REFERENCE PAGE MII-7473 rev. 6/30/2020 BEFORE USE.

Design valid for use only with MiTek® connectors. This design is based only upon parameters shown, and is for an individual building component, not a truss system. Before use, the building designer must verify the applicability of design parameters and properly incorporate this design into the overall building design. Bracing indicated is to prevent buckling of individual truss web and/or chord members only. Additional temporary and permanent bracing is always required for stability and to prevent collapse with possible personal injury and property damage. For general guidance regarding the fabrication, storage, delivery, erection and bracing of trusses and truss systems, see

ANSI/TPI1 Quality Criteria, DSB-89 and BCSI Building Component

Safety Information available from Truss Plate Institute, 2670 Crain Highway, Suite 203 Waldorf, MD 20601



240 Stirling Crescent
 Bradford, ON. L3Z 4L5

Job N0653A	Truss A12	Truss Type COMMON	Qty 6	Ply 1	Buildings A-H Job Reference (optional)	U1530830
---------------	--------------	----------------------	----------	----------	---	----------

Alliance Truss (CA), Abbotsford, BC - V2S 7P6,

8.820 s Aug 30 2024 MiTek Industries, Inc. Thu Sep 12 02:47:50 2024 Page 1

ID:hFyjDMxrTsEK_kgkR0vWWVzFlgc-cdAvYMtCm0pl7GdVfXhTLjLiUOZv705BcBzypmyeVrN

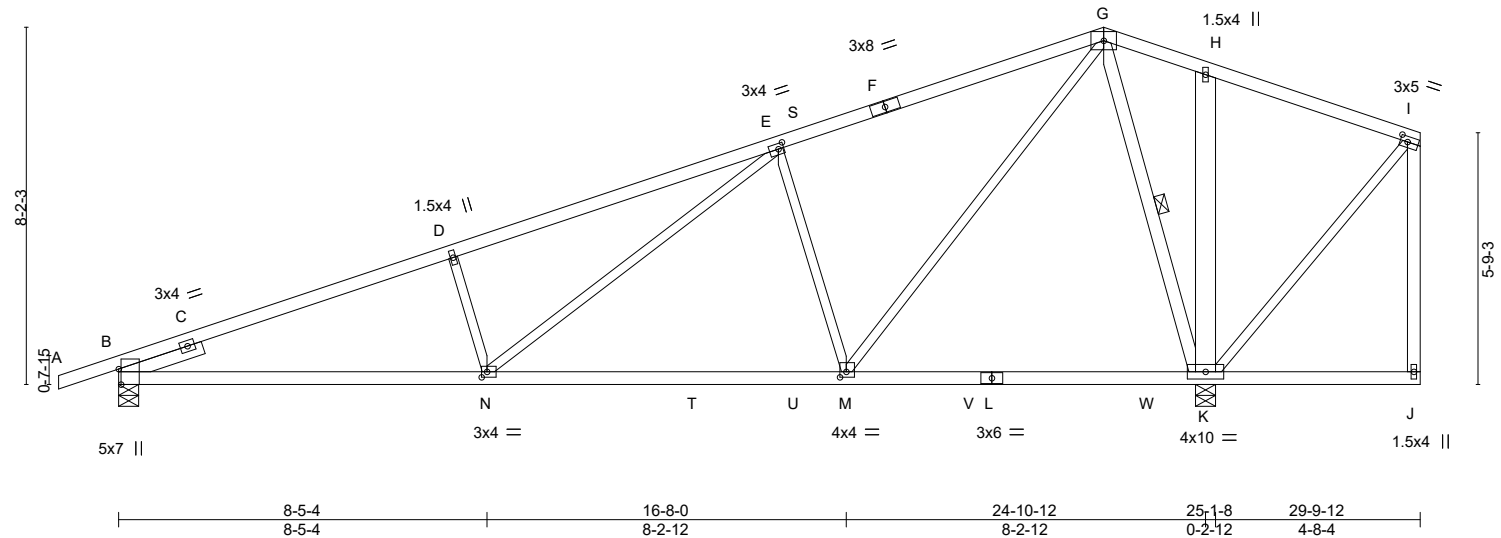
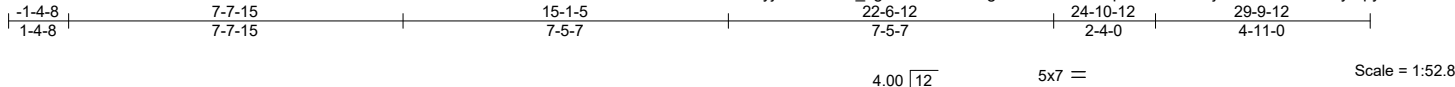

Plate Offsets (X,Y)-- [B:0-4-4,Edge], [E:0-1-8,0-1-8], [I:0-2-0,0-1-8], [M:0-1-12,0-1-8], [N:0-1-8,0-1-8]

LOADING (psf)	SPACING-	CSI.	DEFL.	PLATES	GRIP
TCLL 25.0 (Roof Snow=25.0)	2-0-0 Plate Grip DOL 1.15 Lumber DOL 1.15	TC 0.98 BC 0.88 WB 0.79	in (loc) l/defl L/d Vert(LL) -0.20 M-N >999 360 Vert(CT) -0.36 M-N >826 240 Horz(CT) 0.05 K n/a n/a Wind(LL) 0.07 M-N >999 240	MT20	197/144
TCDL 12.0	Rep Stress Incr YES	Matrix-MS		Weight: 128 lb	FT = 20%
BCLL 0.0 *	Code IBC2018/TPI2014				
BCDL 10.0					

LUMBER-

TOP CHORD 2x4 SPF No.2
 BOT CHORD 2x4 SPF No.2
 WEBS 2x3 SPF No.2 *Except*
 G-K,I-J: 2x4 SPF No.2, H-K: 2x6 SPF No.2
 SLIDER Left 2x4 SPF No.2 2-0-2

BRACING-

TOP CHORD Structural wood sheathing directly applied, except end verticals.
 BOT CHORD Rigid ceiling directly applied or 9-7-3 oc bracing.
 WEBS 1 Row at midpt G-K

REACTIONS.

(size) B=0-5-8, K=0-5-8
 Max Horz B=198(LC 10)
 Max Uplift B=-165(LC 6), K=-161(LC 6)
 Max Grav B=1313(LC 3), K=1776(LC 2)

FORCES. (lb) - Max. Comp./Max. Ten. - All forces 250 (lb) or less except when shown.

TOP CHORD B-D=-2500/248, D-E=-2401/276, E-G=-1381/184, H-I=-9/265
 BOT CHORD B-N=-372/2316, M-N=-223/1462, K-M=-47/295
 WEBS D-N=-461/168, E-N=-132/1007, E-M=-1008/241, G-M=-183/1541, G-K=-1296/184,
 H-K=-480/108, I-K=-269/41

NOTES-

- 1) Wind: ASCE 7-16; Vult=115mph (3-second gust) Vasd=91mph; TCDL=4.2psf; BCDL=5.0psf; h=30ft; Ke=1.00; Cat. II; Exp B; Enclosed; MWFRS (envelope) gable end zone; cantilever left exposed ; end vertical left exposed; Lumber DOL=1.33 plate grip DOL=1.33
- 2) TCLL: ASCE 7-16; Pf=25.0 psf (Lum DOL = 1.15 Plate DOL = 1.15); Is=1.0; Rough Cat B; Partially Exp.; Ce=1.0; Cs=1.00; Ct=1.10
- 3) Unbalanced snow loads have been considered for this design.
- 4) This truss has been designed for greater of min roof live load of 20.0 psf or 2.00 times flat roof load of 25.0 psf on overhangs non-concurrent with other live loads.
- 5) This truss has been designed for a 10.0 psf bottom chord live load nonconcurrent with any other live loads.
- 6) * This truss has been designed for a live load of 20.0psf on the bottom chord in all areas where a rectangle 3-6-0 tall by 2-0-0 wide will fit between the bottom chord and any other members, with BCDL = 10.0psf.
- 7) Provide mechanical connection (by others) of truss to bearing plate capable of withstanding 100 lb uplift at joint(s) except (jt=lb) B=165, K=161.
- 8) This truss is designed in accordance with the 2018 International Building Code section 2306.1 and referenced standard ANSI/TPI 1.



September 12, 2024

WARNING - Verify design parameters and READ NOTES ON THIS AND INCLUDED MITEK REFERENCE PAGE MII-7473 rev. 6/30/2020 BEFORE USE.

Design valid for use only with MiTek® connectors. This design is based only upon parameters shown, and is for an individual building component, not a truss system. Before use, the building designer must verify the applicability of design parameters and properly incorporate this design into the overall building design. Bracing indicated is to prevent buckling of individual truss web and/or chord members only. Additional temporary and permanent bracing is always required for stability and to prevent collapse with possible personal injury and property damage. For general guidance regarding the fabrication, storage, delivery, erection and bracing of trusses and truss systems, see

ANSI/TPI1 Quality Criteria, DSB-89 and BCSI Building Component Safety Information available from Truss Plate Institute, 2670 Crain Highway, Suite 203 Waldorf, MD 20601



240 Stirling Crescent
 Bradford, ON. L3Z 4L5

Job N0653A	Truss A13	Truss Type GABLE	Qty 2	Ply 1	Buildings A-H	U1530831
---------------	--------------	---------------------	----------	----------	---------------	----------

Alliance Truss (CA), Abbotsford, BC - V2S 7P6, 8.820 s Aug 30 2024 MiTek Industries, Inc. Thu Sep 12 02:47:50 2024 Page 1
 ID:hFyjDMxrTsEK_kgkR0vWWVzFlgc-cdAvYMiCmOp17GdVfXhTLjLq9Okv7AHBcBzypmpeVrN

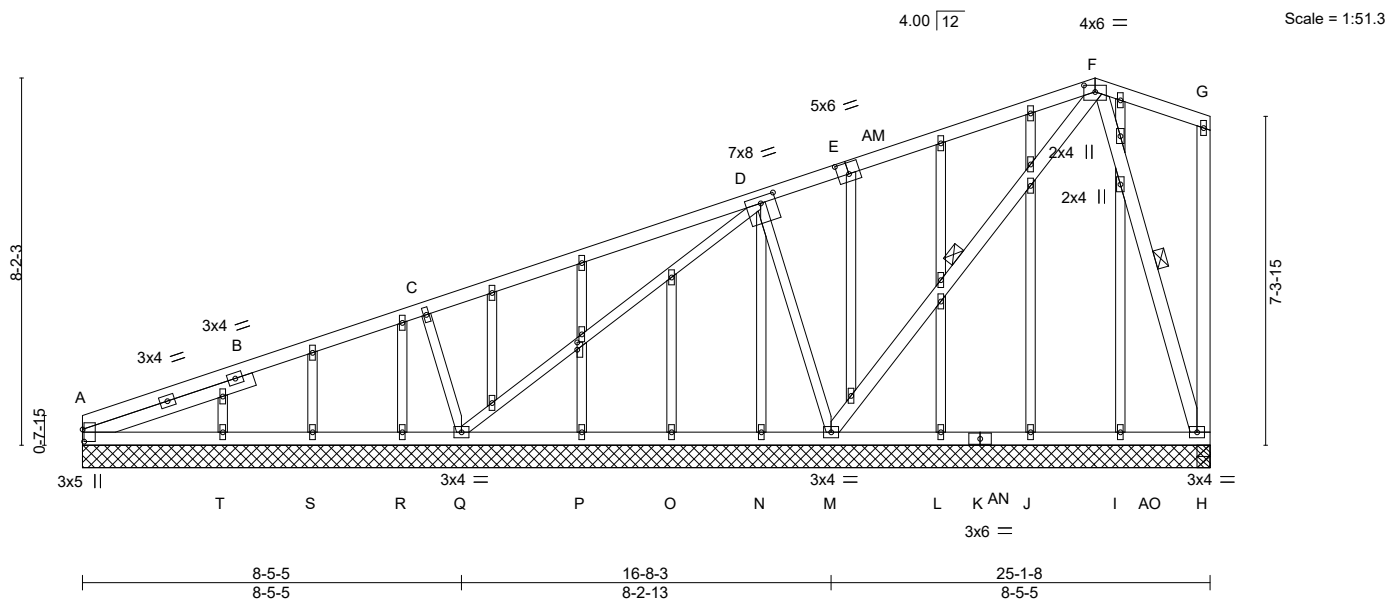

Plate Offsets (X,Y)-- [A:0-3-4,0-0-7], [D:0-4-0,0-1-12], [E:0-3-0,0-3-0], [F:0-3-0,0-1-12], [AF:0-1-15,0-0-0]

LOADING (psf)	SPACING-	CSI.	DEFL.	in (loc)	l/defl	L/d	PLATES	GRIP
TCLL 25.0 (Roof Snow=25.0)	1-0-0 Plate Grip DOL 1.15 Lumber DOL 1.15	TC 0.49 BC 0.18 WB 0.14 Matrix-S	Vert(LL) -0.00 Vert(CT) -0.01 Horz(CT) 0.00 Wind(LL) 0.00	A-T A-T H A-T	>999 >999 n/a >999	360 240 n/a 240	MT20	197/144
TCDL 12.0	Rep Stress Incr NO						Weight: 142 lb	FT = 20%
BCLL 0.0 *	Code IBC2018/TPI2014							
BCDL 10.0								

LUMBER-

TOP CHORD 2x4 SPF No.2
 BOT CHORD 2x4 SPF No.2
 WEBS 2x4 SPF No.2 *Except*
 C-Q,D-Q,D-M: 2x3 SPF No.2
 OTHERS 2x3 SPF No.2
 SLIDER Left 2x4 SPF No.2 4-0-1

BRACING-

TOP CHORD Structural wood sheathing directly applied or 6-0-0 oc purlins, except end verticals.
 BOT CHORD Rigid ceiling directly applied or 10-0-0 oc bracing.
 WEBS 1 Row at midpt F-M, F-H

REACTIONS.

All bearings 25-1-8.
 (lb) - Max Horz A=112(LC 10)
 Max Uplift All uplift 100 lb or less at joint(s) A, Q, M, H, N
 Max Grav All reactions 250 lb or less at joint(s) A, Q, M, H, H, I, J, L, N, O, P, R, S, T

FORCES. (lb) - Max. Comp./Max. Ten. - All forces 250 (lb) or less except when shown.

TOP CHORD A-C=-256/19
 WEBS C-Q=-264/93

NOTES-

- 1) Wind: ASCE 7-16; Vult=115mph (3-second gust) Vasd=91mph; TCDL=4.2psf; BCDL=5.0psf; h=30ft; Ke=1.00; Cat. II; Exp B; Enclosed; MWFRS (envelope) gable end zone; cantilever left exposed ; end vertical left exposed; Lumber DOL=1.33 plate grip DOL=1.33
- 2) Truss designed for wind loads in the plane of the truss only. For studs exposed to wind (normal to the face), see Standard Industry Gable End Details as applicable, or consult qualified building designer as per ANSI/TPI 1.
- 3) TCLL: ASCE 7-16; Pf=25.0 psf (Lum DOL = 1.15 Plate DOL = 1.15); Is=1.0; Rough Cat B; Partially Exp.; Ce=1.0; Cs=1.00; Ct=1.10
- 4) Unbalanced snow loads have been considered for this design.
- 5) All plates are 1.5x4 MT20 unless otherwise indicated.
- 6) Gable studs spaced at 2-0-0 oc.
- 7) This truss has been designed for a 10.0 psf bottom chord live load nonconcurrent with any other live loads.
- 8) * This truss has been designed for a live load of 20.0psf on the bottom chord in all areas where a rectangle 3-6-0 tall by 2-0-0 wide will fit between the bottom chord and any other members, with BCDL = 10.0psf.
- 9) Provide mechanical connection (by others) of truss to bearing plate capable of withstanding 100 lb uplift at joint(s) A, Q, M, H, N.
- 10) This truss is designed in accordance with the 2018 International Building Code section 2306.1 and referenced standard ANSI/TPI 1.



September 12, 2024

WARNING - Verify design parameters and READ NOTES ON THIS AND INCLUDED MITEK REFERENCE PAGE MII-7473 rev. 6/30/2020 BEFORE USE.

Design valid for use only with MiTek® connectors. This design is based only upon parameters shown, and is for an individual building component, not a truss system. Before use, the building designer must verify the applicability of design parameters and properly incorporate this design into the overall building design. Bracing indicated is to prevent buckling of individual truss web and/or chord members only. Additional temporary and permanent bracing is always required for stability and to prevent collapse with possible personal injury and property damage. For general guidance regarding the fabrication, storage, delivery, erection and bracing of trusses and truss systems, see **ANSI/TPI1 Quality Criteria, DSB-89 and BCSI Building Component Safety Information** available from Truss Plate Institute, 2670 Crain Highway, Suite 203 Waldorf, MD 20601



240 Stirling Crescent
 Bradford, ON. L3Z 4L5

Job N0653A	Truss A14	Truss Type GABLE	Qty 2	Ply 1	Buildings A-H Job Reference (optional)	U1530832
---------------	--------------	---------------------	----------	----------	---	----------

Alliance Truss (CA), Abbotsford, BC - V2S 7P6,

8.820 s Aug 30 2024 MiTek Industries, Inc. Thu Sep 12 02:47:52 2024 Page 1

ID:hFyjDMxrTsEK_kgkR0vWWWvzF1gc-Y0lgz1uSld3TNamunyxQ8RDpCQ5b3EU3US3qiyeVrL

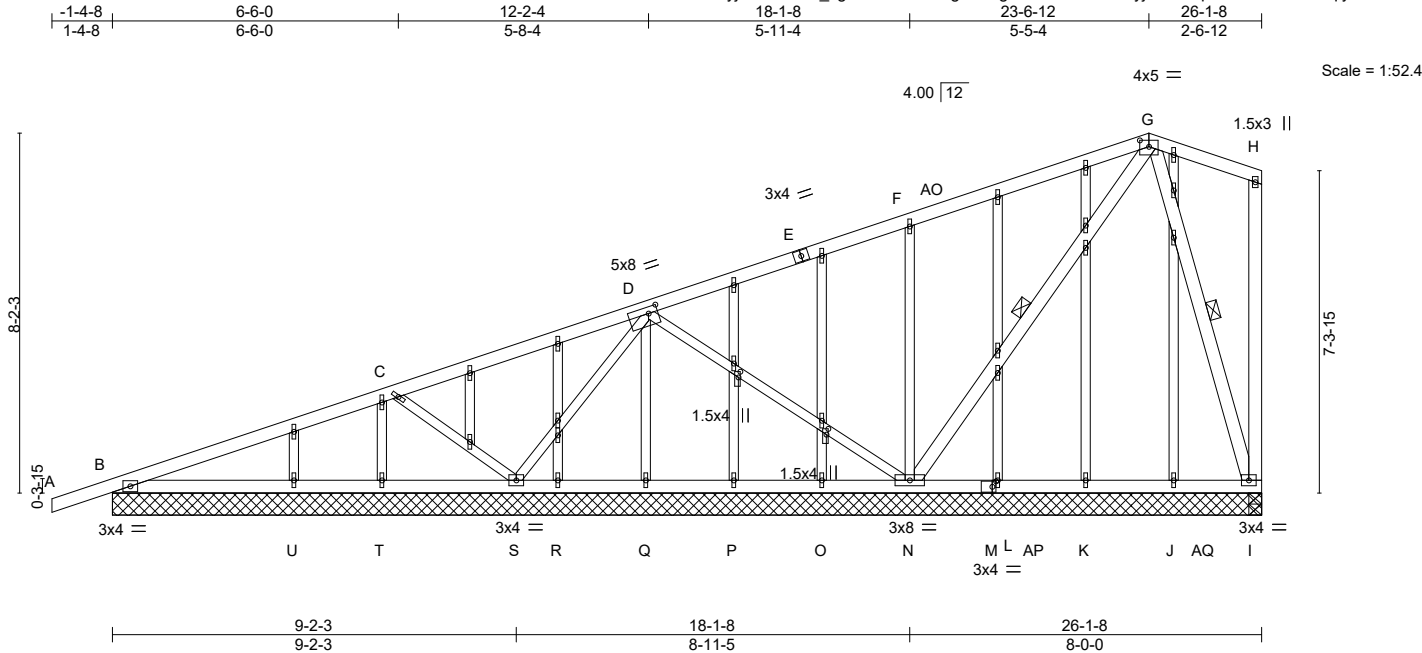

Plate Offsets (X,Y)-- [D:0-2-8,0-1-12], [G:0-2-8,0-1-12], [M:0-1-0,0-1-8], [AF:0-1-9,0-0-8], [AH:0-1-9,0-0-8]

LOADING (psf)	SPACING-	CSI.	DEFL.	PLATES	GRIP
TCLL 25.0 (Roof Snow=25.0)	1-0-0 Plate Grip DOL 1.15	TC 0.29	in (loc) l/defl L/d	MT20	197/144
TCDL 12.0	Lumber DOL 1.15	BC 0.13	Vert(LL) -0.01 B-U >999 360		
BCLL 0.0 *	Rep Stress Incr NO	WB 0.24	Vert(CT) -0.01 B-U >999 240		
BCDL 10.0	Code IBC2018/TPI2014	Matrix-S	Horz(CT) 0.00 S n/a n/a		
			Wind(LL) 0.00 B-U >999 240	Weight: 141 lb	FT = 20%

LUMBER-

TOP CHORD 2x4 SPF No.2
 BOT CHORD 2x4 SPF No.2
 WEBS 2x3 SPF No.2 *Except*
 G-N,H-I,G-I: 2x4 SPF No.2
 OTHERS 2x3 SPF No.2

BRACING-

TOP CHORD Structural wood sheathing directly applied or 6-0-0 oc purlins, except end verticals.
 BOT CHORD Rigid ceiling directly applied or 6-0-0 oc bracing.
 WEBS 1 Row at midpt G-N, G-I

REACTIONS.

All bearings 26-1-8.
 (lb) - Max Horz B=119(LC 6)
 Max Uplift All uplift 100 lb or less at joint(s) B, S, N, I, Q
 Max Grav All reactions 250 lb or less at joint(s) B, I, J, K, L, O, P, Q, R, T, U except S=314(LC 17), N=350(LC 17)

FORCES. (lb) - Max. Comp./Max. Ten. - All forces 250 (lb) or less except when shown.

WEBS C-S=-269/91, F-N=-260/79

NOTES-

- 1) Wind: ASCE 7-16; Vult=115mph (3-second gust) Vasd=91mph; TCDL=4.2psf; BCDL=5.0psf; h=30ft; Ke=1.00; Cat. II; Exp B; Enclosed; MWFRS (envelope) gable end zone; cantilever left exposed ; end vertical left exposed; Lumber DOL=1.33 plate grip DOL=1.33
- 2) Truss designed for wind loads in the plane of the truss only. For studs exposed to wind (normal to the face), see Standard Industry Gable End Details as applicable, or consult qualified building designer as per ANSI/TPI 1.
- 3) TCLL: ASCE 7-16; Pf=25.0 psf (Lum DOL = 1.15 Plate DOL = 1.15); Is=1.0; Rough Cat B; Partially Exp.; Ce=1.0; Cs=1.00; Ct=1.10
- 4) Unbalanced snow loads have been considered for this design.
- 5) This truss has been designed for greater of min roof live load of 20.0 psf or 2.00 times flat roof load of 25.0 psf on overhangs non-concurrent with other live loads.
- 6) All plates are 1x4 MT20 unless otherwise indicated.
- 7) Gable studs spaced at 2-0-0 oc.
- 8) This truss has been designed for a 10.0 psf bottom chord live load nonconcurrent with any other live loads.
- 9) * This truss has been designed for a live load of 20.0psf on the bottom chord in all areas where a rectangle 3-6-0 tall by 2-0-0 wide will fit between the bottom chord and any other members, with BCDL = 10.0psf.
- 10) Provide mechanical connection (by others) of truss to bearing plate capable of withstanding 100 lb uplift at joint(s) B, S, N, I, Q.
- 11) This truss is designed in accordance with the 2018 International Building Code section 2306.1 and referenced standard ANSI/TPI 1.



September 12, 2024

WARNING - Verify design parameters and READ NOTES ON THIS AND INCLUDED MITEK REFERENCE PAGE MII-7473 rev. 6/30/2020 BEFORE USE.

Design valid for use only with MiTek® connectors. This design is based only upon parameters shown, and is for an individual building component, not a truss system. Before use, the building designer must verify the applicability of design parameters and properly incorporate this design into the overall building design. Bracing indicated is to prevent buckling of individual truss web and/or chord members only. Additional temporary and permanent bracing is always required for stability and to prevent collapse with possible personal injury and property damage. For general guidance regarding the fabrication, storage, delivery, erection and bracing of trusses and truss systems, see **ANSI/TPI1 Quality Criteria, DSB-89 and BCSI Building Component Safety Information** available from Truss Plate Institute, 2670 Crain Highway, Suite 203 Waldorf, MD 20601



240 Stirling Crescent
 Bradford, ON. L3Z 4L5

Job N0653A	Truss A15	Truss Type Roof Special	Qty 6	Ply 1	Buildings A-H	U1530833
---------------	--------------	----------------------------	----------	----------	---------------	----------

Alliance Truss (CA), Abbotsford, BC - V2S 7P6, 8.820 s Aug 30 2024 MiTek Industries, Inc. Thu Sep 12 02:47:52 2024 Page 1

ID:hFyjDMxrTsEK_kgkR0vWVvzFlgc-Y0lgz1uSld3TNamunyxQ8R23CGdbutU3US3qiyeVrL

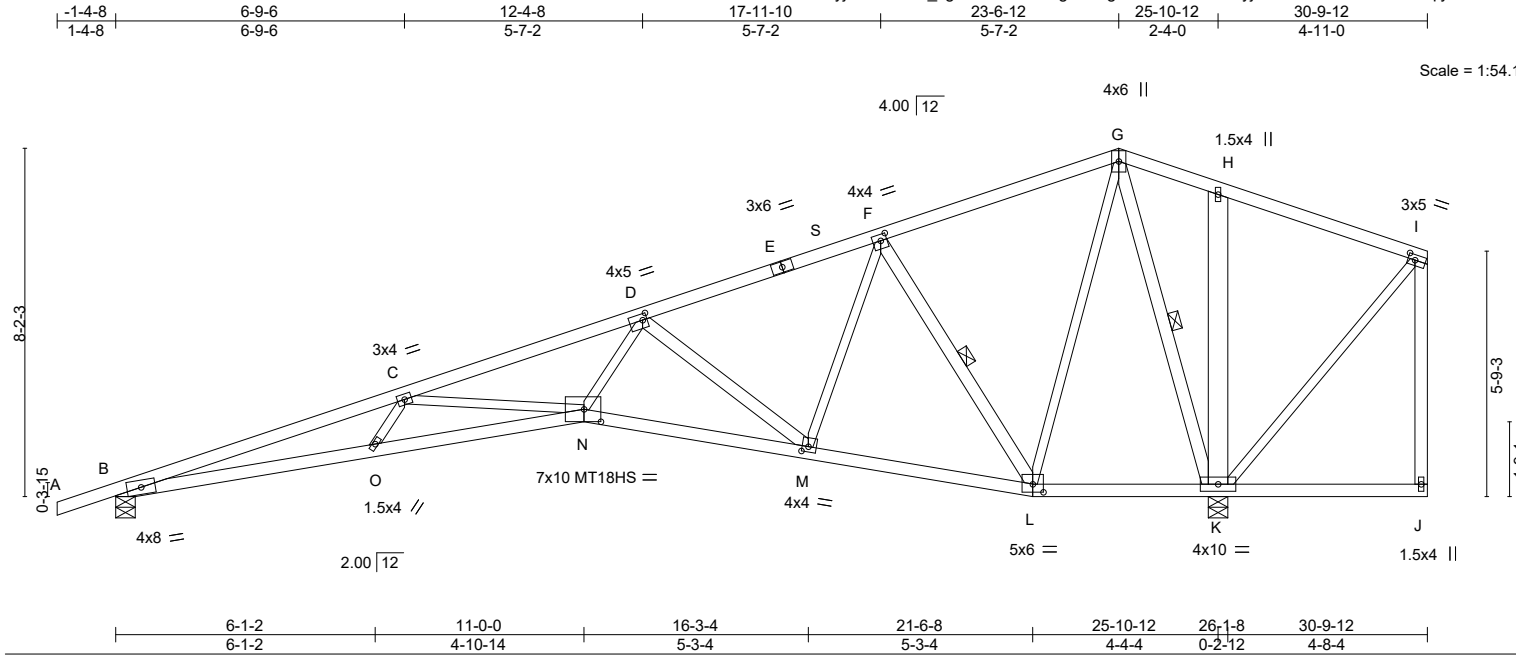

LOADING (psf)	SPACING-	CSI.	DEFL.	PLATES	GRIP
TCLL 25.0 (Roof Snow=25.0)	2-0-0 Plate Grip DOL 1.15 Lumber DOL 1.15	TC 0.98 BC 0.80 WB 0.90	in (loc) l/defl L/d Vert(LL) -0.41 N-O >752 360 Vert(CT) -0.75 N-O >417 240 Horz(CT) 0.30 K n/a n/a Wind(LL) 0.23 N-O >999 240	MT20 MT18HS	197/144 197/144
TCDL 12.0	Rep Stress Incr YES	Matrix-MS		Weight: 138 lb	FT = 20%
BCLL 0.0 *	Code IBC2018/TPI2014				
BCDL 10.0					

LUMBER-	BRACING-
TOP CHORD 2x4 SPF No.2	TOP CHORD Structural wood sheathing directly applied, except end verticals.
BOT CHORD 2x4 SPF No.2 *Except*	BOT CHORD Rigid ceiling directly applied or 9-2-5 oc bracing.
B-N: 2x4 SPF 2100F 1.8E	WEBS 1 Row at midpt F-L, G-K
WEBS 2x3 SPF No.2 *Except*	
D-M,F-L,G-K,I-J: 2x4 SPF No.2, H-K: 2x6 SPF No.2	

REACTIONS. (size) B=0-5-8, K=0-5-8
 Max Horz B=166(LC 9)
 Max Uplift B=-182(LC 6), K=-200(LC 7)
 Max Grav B=1339(LC 17), K=1704(LC 1)

FORCES. (lb) - Max. Comp./Max. Ten. - All forces 250 (lb) or less except when shown.
 TOP CHORD B-C=-5336/630, C-D=-4305/511, D-F=-1825/226, F-G=-720/138, H-I=-54/272
 BOT CHORD B-O=-679/5068, N-O=-716/5048, M-N=-412/3163, L-M=-144/1361, K-L=-25/299
 WEBS C-N=-971/206, D-N=-192/1829, D-M=-1881/304, F-M=-97/1089, F-L=-1465/228,
 G-L=-134/1151, G-K=-1320/143, H-K=-503/117, I-K=-280/56

- NOTES-**
- 1) Wind: ASCE 7-16; Vult=115mph (3-second gust) Vasd=91mph; TCDL=4.2psf; BCDL=5.0psf; h=30ft; Ke=1.00; Cat. II; Exp B; Enclosed; MWFRS (envelope) gable end zone; cantilever left and right exposed; end vertical left and right exposed; Lumber DOL=1.33 plate grip DOL=1.33
 - 2) TCLL: ASCE 7-16; Pf=25.0 psf (Lum DOL = 1.15 Plate DOL = 1.15); Is=1.0; Rough Cat B; Partially Exp.; Ce=1.0; Cs=1.00; Ct=1.10
 - 3) Unbalanced snow loads have been considered for this design.
 - 4) This truss has been designed for greater of min roof live load of 20.0 psf or 2.00 times flat roof load of 25.0 psf on overhangs non-concurrent with other live loads.
 - 5) All plates are MT20 plates unless otherwise indicated.
 - 6) This truss has been designed for a 10.0 psf bottom chord live load nonconcurrent with any other live loads.
 - 7) * This truss has been designed for a live load of 20.0psf on the bottom chord in all areas where a rectangle 3-6-0 tall by 2-0-0 wide will fit between the bottom chord and any other members.
 - 8) Bearing at joint(s) B considers parallel to grain value using ANSI/TPI 1 angle to grain formula. Building designer should verify capacity of bearing surface.
 - 9) Provide mechanical connection (by others) of truss to bearing plate capable of withstanding 100 lb uplift at joint(s) except (jt=lb) B=182, K=200.
 - 10) This truss is designed in accordance with the 2018 International Building Code section 2306.1 and referenced standard ANSI/TPI 1.



September 12, 2024

WARNING - Verify design parameters and READ NOTES ON THIS AND INCLUDED MITEK REFERENCE PAGE MII-7473 rev. 6/30/2020 BEFORE USE.
 Design valid for use only with MiTek® connectors. This design is based only upon parameters shown, and is for an individual building component, not a truss system. Before use, the building designer must verify the applicability of design parameters and properly incorporate this design into the overall building design. Bracing indicated is to prevent buckling of individual truss web and/or chord members only. Additional temporary and permanent bracing is always required for stability and to prevent collapse with possible personal injury and property damage. For general guidance regarding the fabrication, storage, delivery, erection and bracing of trusses and truss systems, see **ANSI/TPI1 Quality Criteria, DSB-89 and BCSI Building Component Safety Information** available from Truss Plate Institute, 2670 Crain Highway, Suite 203 Waldorf, MD 20601



240 Stirling Crescent
Bradford, ON. L3Z 4L5

Job	Truss	Truss Type	Qty	Ply	Buildings A-H	U1530834
N0653A	A16	GABLE	2	1		

Alliance Truss (CA), Abbotsford, BC - V2S 7P6, 8.820 s Aug 30 2024 MiTek Industries, Inc. Thu Sep 12 02:47:53 2024 Page 1
 ID:hFyjDMxrTsEK_kgR0vWWVzFlgc-0Cs2ANv53xBK_kL4KfEzLzF4caXKL9d18BdN8yeVrk

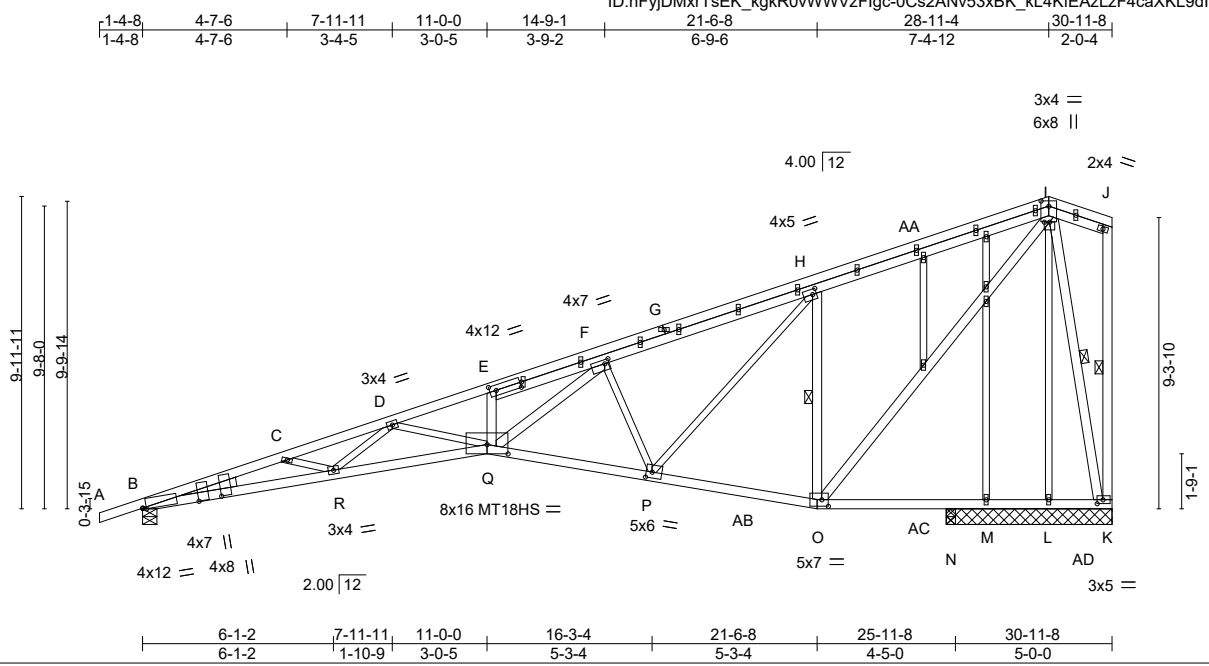

Plate Offsets (X,Y)-- [B:0-1-7,Edge], [B:0-0-14,1-9-12], [B:0-0-6,2-6-10], [E:0-2-0,0-0-1], [E:0-2-8,0-2-0], [F:0-1-12,0-1-8], [H:0-1-8,0-2-0], [I:0-2-0,0-3-0], [I:0-2-0,0-0-0], [K:0-2-4,0-1-8], [O:0-2-8,0-2-8], [P:0-2-4,0-2-4], [Q:0-8-0,0-3-9]

LOADING (psf)	SPACING-	CSI.	DEFL.	in (loc)	l/defl	L/d	PLATES	GRIP
TCLL 25.0	2-0-0	TC 0.90	Vert(LL) -0.66	Q-R	>468	360	MT20	197/144
(Roof Snow=25.0)	Plate Grip DOL 1.15	BC 0.95	Vert(CT) -1.20	Q-R	>259	240	MT18HS	197/144
TCDL 12.0	Lumber DOL 1.15	WB 0.90	Horz(CT) 0.42	K	n/a	n/a		
BCLL 0.0 *	Rep Stress Incr YES	Matrix-MS	Wind(LL) 0.38	Q-R	>817	240		
BCDL 10.0	Code IBC2018/TPI2014						Weight: 181 lb	FT = 20%

LUMBER-	BRACING-
TOP CHORD 2x4 SPF No.2 *Except* A-G: 2x4 SPF 2100F 1.8E	TOP CHORD Structural wood sheathing directly applied or 1-7-8 oc purlins, except end verticals.
BOT CHORD 2x4 SPF No.2 *Except* B-Q: 2x4 SPF 2100F 1.8E	BOT CHORD Rigid ceiling directly applied or 2-2-0 oc bracing.
WEBS 2x4 SPF No.2 *Except* D-Q,F-P,H-P,D-R,C-R: 2x3 SPF No.2	WEBS 1 Row at midpt H-O, J-K, I-K
OTHERS 2x3 SPF No.2	
WEDGE Left: 2x4 SPF No.2	

REACTIONS. All bearings 5-3-8 except (jt=length) B=0-5-8, N=0-3-8.
 (lb) - Max Horz B=289(LC 9)
 Max Uplift All uplift 100 lb or less at joint(s) L, N except B=-208(LC 6), K=-185(LC 6), M=-480(LC 17)
 Max Grav All reactions 250 lb or less at joint(s) M except B=1529(LC 3), K=1212(LC 17), L=251(LC 21), N=722(LC 3)

FORCES. (lb) - Max. Comp./Max. Ten. - All forces 250 (lb) or less except when shown.
 TOP CHORD B-C=-7397/948, C-D=-7170/879, D-E=-6314/798, E-F=-6399/846, F-H=-2712/371, H-I=-1441/294
 BOT CHORD B-R=-1027/7170, Q-R=-964/6689, P-Q=-454/3260, O-P=-172/1360, N-O=-91/256, M-N=-91/256, L-M=-91/256, K-L=-91/256
 WEBS D-Q=-605/137, F-P=-1635/303, H-P=-228/1842, H-O=-1557/324, I-O=-296/1675, I-K=-1335/206, E-Q=-357/86, D-R=0/324, C-R=-301/97, F-Q=-491/3657

- NOTES-**
- 1) Wind: ASCE 7-16; Vult=115mph (3-second gust) Vasd=91mph; TCDL=4.2psf; BCDL=5.0psf; h=30ft; Ke=1.00; Cat. II; Exp B; Enclosed; MWFRS (envelope) gable end zone; cantilever left and right exposed ; end vertical left and right exposed; Lumber DOL=1.33 plate grip DOL=1.33
 - 2) Truss designed for wind loads in the plane of the truss only. For studs exposed to wind (normal to the face), see Standard Industry Gable End Details as applicable, or consult qualified building designer as per ANSI/TPI 1.
 - 3) TCLL: ASCE 7-16; Pf=25.0 psf (Lum DOL = 1.15 Plate DOL = 1.15); Is=1.0; Rough Cat B; Partially Exp.; Ce=1.0; Cs=1.00; Ct=1.10
 - 4) Unbalanced snow loads have been considered for this design.
 - 5) This truss has been designed for greater of min roof live load of 20.0 psf or 2.00 times flat roof load of 25.0 psf on overhangs non-concurrent with other live loads.
 - 6) All plates are MT20 plates unless otherwise indicated.
 - 7) All plates are 1.5x4 MT20 unless otherwise indicated.
 - 8) Gable studs spaced at 2-0-0 oc.
 - 9) This truss has been designed for a 10.0 psf bottom chord live load nonconcurrent with any other live loads.



September 12, 2024

Job	Truss	Truss Type	Qty	Ply	Buildings A-H
N0653A	A16	GABLE	2	1	U1530834

Alliance Truss (CA), Abbotsford, BC - V2S 7P6,

8.820 s Aug 30 2024 MiTek Industries, Inc. Thu Sep 12 02:47:53 2024 Page 2
ID:hFyjDMxrTsEK_kgkR0vWWVzF1gc-0Cs2ANv53xBK_kL4KfEzLzF4caXKL9dl8BdN8yeVrK**NOTES-**

- 10) * This truss has been designed for a live load of 20.0psf on the bottom chord in all areas where a rectangle 3-6-0 tall by 2-0-0 wide will fit between the bottom chord and any other members, with BCDL = 10.0psf.
- 11) Bearing at joint(s) B considers parallel to grain value using ANSI/TPI 1 angle to grain formula. Building designer should verify capacity of bearing surface.
- 12) Provide mechanical connection (by others) of truss to bearing plate capable of withstanding 100 lb uplift at joint(s) L, N except (jt=lb) B=208, K=185, M=480.
- 13) This truss is designed in accordance with the 2018 International Building Code section 2306.1 and referenced standard ANSI/TPI 1.
- 14) No notches allowed in overhang and 120800 from left end and 0 from right end or 12" along rake from scarf, whichever is larger. Minimum 1.5x4 tie plates required at 2-0-0 o.c. maximum between the stacking chords. For edge-wise notching, provide at least one tie plate between each notch.

WARNING - Verify design parameters and READ NOTES ON THIS AND INCLUDED MITEK REFERENCE PAGE MII-7473 rev. 6/30/2020 BEFORE USE.

Design valid for use only with MiTek® connectors. This design is based only upon parameters shown, and is for an individual building component, not a truss system. Before use, the building designer must verify the applicability of design parameters and properly incorporate this design into the overall building design. Bracing indicated is to prevent buckling of individual truss web and/or chord members only. Additional temporary and permanent bracing is always required for stability and to prevent collapse with possible personal injury and property damage. For general guidance regarding the fabrication, storage, delivery, erection and bracing of trusses and truss systems, see

Safety Information available from Truss Plate Institute, 2670 Crain Highway, Suite 203 Waldorf, MD 20601

ANSI/TPI1 Quality Criteria, DSB-89 and BCSI Building Component



240 Stirling Crescent
Bradford, ON. L3Z 4L5

Job N0653A	Truss A17	Truss Type Roof Special	Qty 11	Ply 1	Buildings A-H	U1530835
---------------	--------------	----------------------------	-----------	----------	---------------	----------

Alliance Truss (CA), Abbotsford, BC - V2S 7P6, 8.820 s Aug 30 2024 MiTek Industries, Inc. Thu Sep 12 02:47:54 2024 Page 1

ID:hFyjDMxrTsEK_kgkR0vWWWzF1gc-VPQQOjwjqFJBcuwHuNIPVZWOi0wc3rcnWoxAvayeVrJ

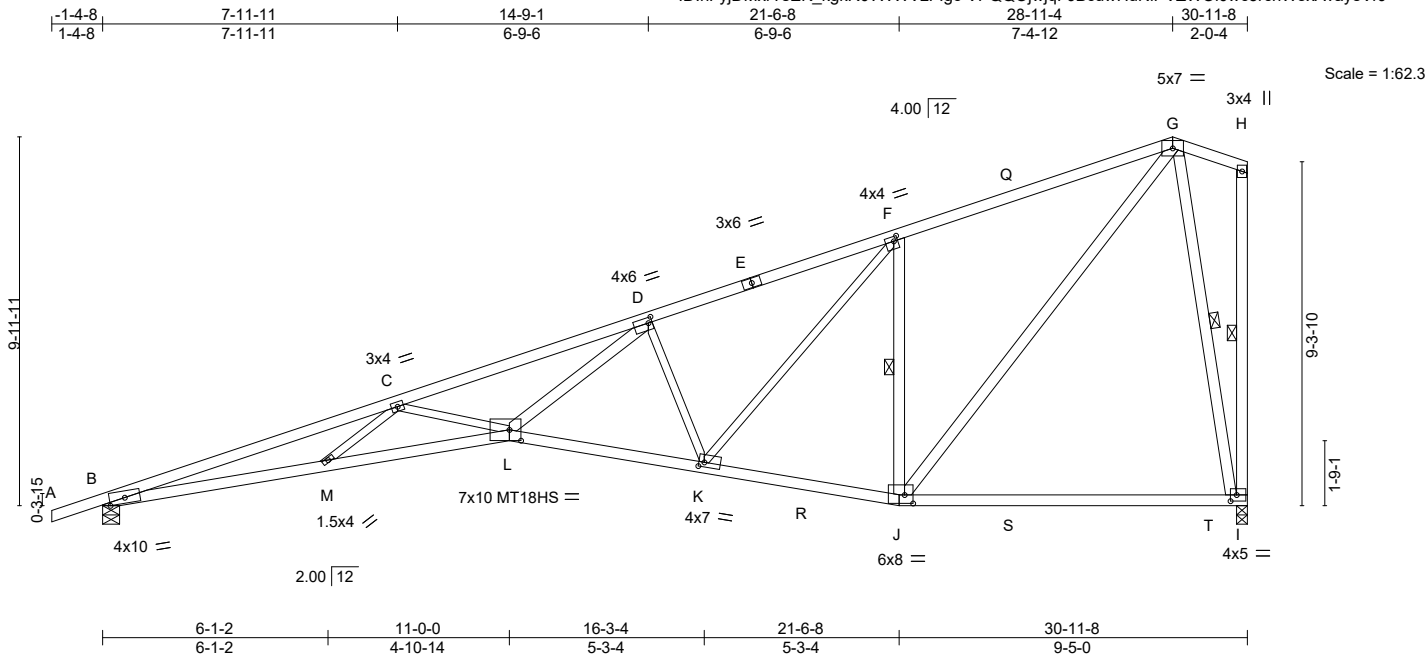

Plate Offsets (X,Y)-- [D:0-1-4,0-1-12], [F:0-1-4,0-1-8], [I:0-2-0,0-2-0], [J:0-2-12,0-2-12], [K:0-1-12,0-1-8], [L:0-3-12,0-3-8]

LOADING (psf)	SPACING-	CSI.	DEFL.	PLATES	GRIP
TCLL 25.0 (Roof Snow=25.0)	2-0-0 Plate Grip DOL 1.15 Lumber DOL 1.15	TC 0.90 BC 0.89 WB 0.76	in (loc) l/defl L/d Vert(LL) -0.56 L-M >663 360 Vert(CT) -1.01 L-M >367 240 Horz(CT) 0.37 I n/a n/a Wind(LL) 0.30 L >999 240	MT20 MT18HS	197/144 197/144
TCDL 12.0	Rep Stress Incr YES Code IBC2018/TPI2014	Matrix-MS		Weight: 137 lb	FT = 20%
BCLL 0.0 *					
BCDL 10.0					

LUMBER-

TOP CHORD 2x4 SPF No.2 *Except*
A-E: 2x4 SPF 2100F 1.8E
BOT CHORD 2x4 SPF 2100F 1.8E *Except*
J-L: 2x4 SPF No.2
WEBS 2x4 SPF No.2 *Except*
C-M,C-L,D-K,F-K: 2x3 SPF No.2

BRACING-

TOP CHORD Structural wood sheathing directly applied, except end verticals.
BOT CHORD Rigid ceiling directly applied or 8-3-12 oc bracing.
WEBS 1 Row at midpt F-J, H-I, G-I

REACTIONS.

(size) B=0-5-8, I=0-3-8
Max Horz B=299(LC 9)
Max Uplift B=-205(LC 6), I=-185(LC 6)
Max Grav B=1602(LC 3), I=1587(LC 3)

FORCES. (lb) - Max. Comp./Max. Ten. - All forces 250 (lb) or less except when shown.

TOP CHORD B-C=-6801/760, C-D=-5845/678, D-F=-2805/358, F-G=-1645/285
BOT CHORD B-M=-831/6480, L-M=-902/6335, K-L=-403/3197, J-K=-151/1514, I-J=-85/288
WEBS C-M=0/291, C-L=-849/228, D-L=-359/3077, D-K=-1547/290, F-K=-231/1755,
F-J=-1525/322, G-J=-287/1963, G-I=-1439/199

NOTES-

- Wind: ASCE 7-16; Vult=115mph (3-second gust) Vasd=91mph; TCDL=4.2psf; BCDL=5.0psf; h=30ft; Ke=1.00; Cat. II; Exp B; Enclosed; MWFRS (envelope) gable end zone; cantilever left and right exposed; end vertical left and right exposed; Lumber DOL=1.33 plate grip DOL=1.33
- TCLL: ASCE 7-16; Pf=25.0 psf (Lum DOL = 1.15 Plate DOL = 1.15); Is=1.0; Rough Cat B; Partially Exp.; Ce=1.0; Cs=1.00; Ct=1.10
- Unbalanced snow loads have been considered for this design.
- This truss has been designed for greater of min roof live load of 20.0 psf or 2.00 times flat roof load of 25.0 psf on overhangs non-concurrent with other live loads.
- All plates are MT20 plates unless otherwise indicated.
- This truss has been designed for a 10.0 psf bottom chord live load nonconcurrent with any other live loads.
- * This truss has been designed for a live load of 20.0psf on the bottom chord in all areas where a rectangle 3-6-0 tall by 2-0-0 wide will fit between the bottom chord and any other members, with BCDL = 10.0psf.
- Bearing at joint(s) B considers parallel to grain value using ANSI/TPI 1 angle to grain formula. Building designer should verify capacity of bearing surface.
- Provide mechanical connection (by others) of truss to bearing plate capable of withstanding 100 lb uplift at joint(s) except (jt=lb) B=205, I=185.
- This truss is designed in accordance with the 2018 International Building Code section 2306.1 and referenced standard ANSI/TPI 1.



September 12, 2024

WARNING - Verify design parameters and READ NOTES ON THIS AND INCLUDED MITEK REFERENCE PAGE MII-7473 rev. 6/30/2020 BEFORE USE.

Design valid for use only with MiTek® connectors. This design is based only upon parameters shown, and is for an individual building component, not a truss system. Before use, the building designer must verify the applicability of design parameters and properly incorporate this design into the overall building design. Bracing indicated is to prevent buckling of individual truss web and/or chord members only. Additional temporary and permanent bracing is always required for stability and to prevent collapse with possible personal injury and property damage. For general guidance regarding the fabrication, storage, delivery, erection and bracing of trusses and truss systems, see

Safety Information available from Truss Plate Institute, 2670 Crain Highway, Suite 203 Waldorf, MD 20601



240 Stirling Crescent
Bradford, ON. L3Z 4L5

Job N0653A	Truss A18	Truss Type ROOF SPECIAL	Qty 1	Ply 1	Buildings A-H Job Reference (optional)	U1530836
---------------	--------------	----------------------------	----------	----------	---	----------

Alliance Truss (CA), Abbotsford, BC - V2S 7P6,

8.820 s Aug 30 2024 MiTek Industries, Inc. Thu Sep 12 02:47:55 2024 Page 1
 ID:hFyjDMxrTsEK_kgkR0vWWVzFlgc-zb_ob3xLaYR2E2VTS4He2m3ZIPFpolowISgjR1yeVrl

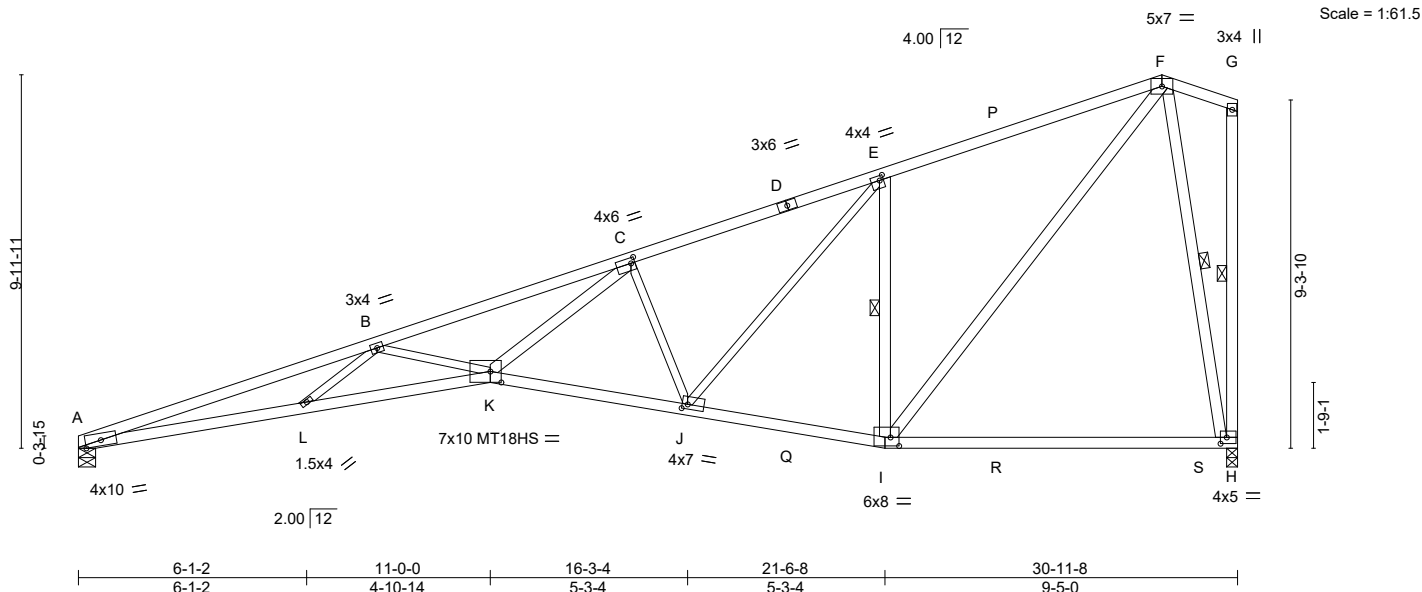

Plate Offsets (X,Y)-- [C:0-1-4,0-1-12], [E:0-1-4,0-1-8], [H:0-2-0,0-2-0], [I:0-2-12,0-2-12], [J:0-1-12,0-1-8], [K:0-3-8,0-3-8]

LOADING (psf)		SPACING-		CSI.		DEFL.		PLATES		GRIP	
TCLL	25.0	Plate Grip DOL	1.15	TC	0.95	Vert(LL)	-0.56 K-L >663	L/d	360	MT20	197/144
(Roof Snow=25.0)		Lumber DOL	1.15	BC	0.90	Vert(CT)	-1.01 K-L >366		240	MT18HS	197/144
TCDL	12.0	Rep Stress Incr	YES	WB	0.76	Horz(CT)	0.37 H n/a		n/a		
BCLL	0.0 *	Code IBC2018/TPI2014		Matrix-MS		Wind(LL)	0.31 K >999		240	Weight: 135 lb	FT = 20%
BCDL	10.0										

LUMBER-

TOP CHORD 2x4 SPF No.2 *Except*
 A-D: 2x4 SPF 2100F 1.8E
 BOT CHORD 2x4 SPF 2100F 1.8E *Except*
 I-K: 2x4 SPF No.2
 WEBS 2x4 SPF No.2 *Except*
 B-L,B-K,C-J,E-J: 2x3 SPF No.2

BRACING-

TOP CHORD Structural wood sheathing directly applied, except end verticals.
 BOT CHORD Rigid ceiling directly applied or 8-3-2 oc bracing.
 WEBS 1 Row at midpt E-I, G-H, F-H

REACTIONS.

(size) A=0-5-8, H=0-3-8
 Max Horz A=292(LC 9)
 Max Uplift A=-160(LC 6), H=-186(LC 6)
 Max Grav A=1515(LC 3), H=1589(LC 3)

FORCES. (lb) - Max. Comp./Max. Ten. - All forces 250 (lb) or less except when shown.

TOP CHORD A-B=-6852/778, B-C=-5866/686, C-E=-2810/361, E-F=-1647/287
 BOT CHORD A-L=-847/6531, K-L=-913/6372, J-K=-405/3204, I-J=-152/1517, H-I=-85/288
 WEBS B-L=0/297, B-K=-870/233, C-K=-365/3093, C-J=-1553/292, E-J=-232/1760,
 E-I=-1528/323, F-I=-288/1966, F-H=-1441/199

NOTES-

- 1) Wind: ASCE 7-16; Vult=115mph (3-second gust) Vasd=91mph; TCDL=4.2psf; BCDL=5.0psf; h=30ft; Ke=1.00; Cat. II; Exp B; Enclosed; MWFRS (envelope) gable end zone; cantilever left and right exposed; end vertical left and right exposed; Lumber DOL=1.33 plate grip DOL=1.33
- 2) TCLL: ASCE 7-16; Pf=25.0 psf (Lum DOL = 1.15 Plate DOL = 1.15); Is=1.0; Rough Cat B; Partially Exp.; Ce=1.0; Cs=1.00; Ct=1.10
- 3) Unbalanced snow loads have been considered for this design.
- 4) All plates are MT20 plates unless otherwise indicated.
- 5) This truss has been designed for a 10.0 psf bottom chord live load nonconcurrent with any other live loads.
- 6) * This truss has been designed for a live load of 20.0psf on the bottom chord in all areas where a rectangle 3-6-0 tall by 2-0-0 wide will fit between the bottom chord and any other members, with BCDL = 10.0psf.
- 7) Bearing at joint(s) A considers parallel to grain value using ANSI/TPI 1 angle to grain formula. Building designer should verify capacity of bearing surface.
- 8) Provide mechanical connection (by others) of truss to bearing plate capable of withstanding 100 lb uplift at joint(s) except (jt=lb) A=160, H=186.
- 9) This truss is designed in accordance with the 2018 International Building Code section 2306.1 and referenced standard ANSI/TPI 1.



September 12, 2024

WARNING - Verify design parameters and READ NOTES ON THIS AND INCLUDED MITEK REFERENCE PAGE MII-7473 rev. 6/30/2020 BEFORE USE.

Design valid for use only with MiTek® connectors. This design is based only upon parameters shown, and is for an individual building component, not a truss system. Before use, the building designer must verify the applicability of design parameters and properly incorporate this design into the overall building design. Bracing indicated is to prevent buckling of individual truss web and/or chord members only. Additional temporary and permanent bracing is always required for stability and to prevent collapse with possible personal injury and property damage. For general guidance regarding the fabrication, storage, delivery, erection and bracing of trusses and truss systems, see **ANSI/TPI1 Quality Criteria, DSB-89 and BCSI Building Component Safety Information** available from Truss Plate Institute, 2670 Crain Highway, Suite 203 Waldorf, MD 20601



240 Stirling Crescent
 Bradford, ON. L3Z 4L5

Job N0653A	Truss A19	Truss Type GABLE	Qty 1	Ply 1	Buildings A-H Job Reference (optional)	U1530837
---------------	--------------	---------------------	----------	----------	---	----------

Alliance Truss (CA), Abbotsford, BC - V2S 7P6, 8.820 s Aug 30 2024 MiTek Industries, Inc. Thu Sep 12 02:47:56 2024 Page 1

ID:hFyjDMxrTsEK_kgkR0vWWVzFlgc-RnXApPxzLsZvrB4f0notb_bnYpdmXio4_6QH_TyeVrH

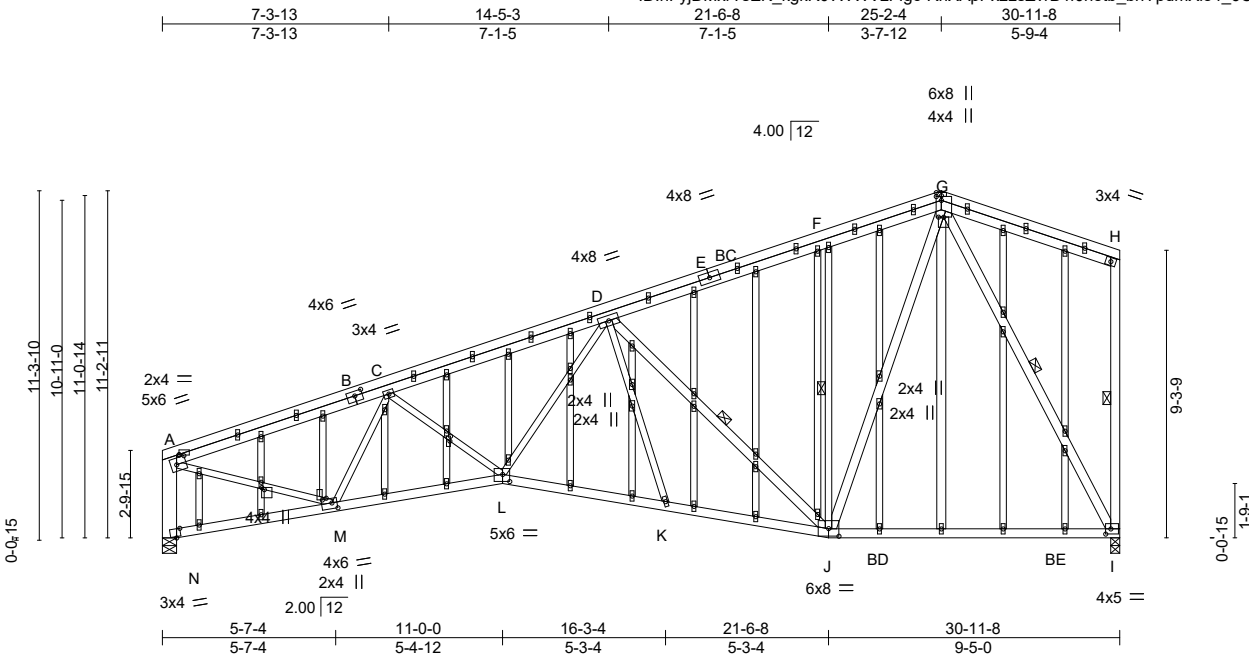

Scale = 1:74.5

Plate Offsets (X,Y)-- [A:0-3-12,0-2-8], [A:0-0-0,0-0-4], [B:0-3-0,0-1-12], [G:0-2-0,Edge], [G:0-1-8,0-2-0], [G:0-0-1,0-2-0], [I:0-2-0,0-2-0], [J:0-4-0,0-2-15], [L:0-2-12,0-2-12], [M:0-2-0,0-2-4], [M:0-0-11,0-1-8], [N:0-1-13,Edge], [AJ:0-1-14,0-0-4], [AP:0-0-13,0-1-0]

LOADING (psf)	SPACING-	CSI.	DEFL.	PLATES	GRIP
TCLL 25.0 (Roof Snow=25.0)	2-0-0	TC 0.75	in (loc) l/defl L/d	MT20	197/144
TCDL 12.0	Plate Grip DOL 1.15	BC 0.79	Vert(LL) -0.44 I-J >829 360		
BCLL 0.0 *	Lumber DOL 1.15	WB 0.90	Vert(CT) -0.70 I-J >521 240		
BCDL 10.0	Rep Stress Incr YES	Matrix-MS	Horz(CT) 0.13 I n/a n/a		
	Code IBC2018/TPI2014		Wind(LL) 0.08 L >999 240	Weight: 264 lb	FT = 20%

LUMBER-

TOP CHORD 2x4 SPF No.2
 BOT CHORD 2x4 SPF No.2 *Except*
 I-J: 2x4 SPF 2100F 1.8E
 WEBS 2x3 SPF No.2 *Except*
 D-J,G-J,H-I,G-I: 2x4 SPF No.2, A-N: 2x6 SPF No.2
 OTHERS 2x3 SPF No.2 *Except*
 G-O: 2x4 SPF No.2

BRACING-

TOP CHORD Structural wood sheathing directly applied or 2-2-0 oc purlins, except end verticals.
 BOT CHORD Rigid ceiling directly applied or 9-11-12 oc bracing.
 WEBS 1 Row at midpt D-J, F-J, H-I, G-I

REACTIONS.

(size) I=0-3-8, N=0-5-8
 Max Horz N=259(LC 7)
 Max Uplift I=-151(LC 6), N=-156(LC 6)
 Max Grav I=1547(LC 2), N=1523(LC 3)

FORCES. (lb) - Max. Comp./Max. Ten. - All forces 250 (lb) or less except when shown.

TOP CHORD A-C=-2234/231, C-D=-2811/333, D-F=-1293/187, F-G=-1280/243, A-N=-1448/190, H-I=-307/71
 BOT CHORD M-N=-254/101, L-M=-347/2486, K-L=-237/2128, J-K=-219/2182, I-J=-115/668
 WEBS C-M=-940/175, D-L=-103/959, D-J=-1377/202, F-J=-594/151, G-J=-197/1491, A-M=-189/2083, G-I=-1384/147

NOTES-

- Wind: ASCE 7-16; Vult=115mph (3-second gust) Vasd=91mph; TCDL=4.2psf; BCDL=5.0psf; h=30ft; Ke=1.00; Cat. II; Exp B; Enclosed; MWFRS (envelope) gable end zone; cantilever left and right exposed; end vertical left and right exposed; Lumber DOL=1.33 plate grip DOL=1.33
- Truss designed for wind loads in the plane of the truss only. For studs exposed to wind (normal to the face), see Standard Industry Gable End Details as applicable, or consult qualified building designer as per ANSI/TPI 1.
- TCLL: ASCE 7-16; Pf=25.0 psf (Lum DOL = 1.15 Plate DOL = 1.15); Is=1.0; Rough Cat B; Partially Exp.; Ce=1.0; Cs=1.00; Ct=1.10
- Unbalanced snow loads have been considered for this design.
- All plates are 1.5x4 MT20 unless otherwise indicated.
- Gable studs spaced at 2-0-0 oc.
- This truss has been designed for a 10.0 psf bottom chord live load nonconcurrent with any other live loads.
- * This truss has been designed for a live load of 20.0psf on the bottom chord in all areas where a rectangle 3-6-0 tall by 2-0-0 wide will fit between the bottom chord and any other members, with BCDL = 10.0psf.
- Bearing at joint(s) N considers parallel to grain value using ANSI/TPI 1 angle to grain formula. Building designer should verify capacity of bearing surface.
- Provide mechanical connection (by others) of truss to bearing plate capable of withstanding 100 lb uplift at joint(s) except (jt=lb) I=151, N=156.
- This truss is designed in accordance with the 2018 International Building Code section 2306.1 and referenced standard ANSI/TPI 1.



September 12, 2024

Continued on page 2

WARNING - Verify design parameters and READ NOTES ON THIS AND INCLUDED MITEK REFERENCE PAGE MII-7473 rev. 6/30/2020 BEFORE USE.

Design valid for use only with MiTek® connectors. This design is based only upon parameters shown, and is for an individual building component, not a truss system. Before use, the building designer must verify the applicability of design parameters and properly incorporate this design into the overall building design. Bracing indicated is to prevent buckling of individual truss web and/or chord members only. Additional temporary and permanent bracing is always required for stability and to prevent collapse with possible personal injury and property damage. For general guidance regarding the fabrication, storage, delivery, erection and bracing of trusses and truss systems, see

Safety Information available from Truss Plate Institute, 2670 Crain Highway, Suite 203 Waldorf, MD 20601



240 Stirling Crescent
 Bradford, ON. L3Z 4L5

Job	Truss	Truss Type	Qty	Ply	Buildings A-H
N0653A	A19	GABLE	1	1	U1530837

Alliance Truss (CA), Abbotsford, BC - V2S 7P6,

8.820 s Aug 30 2024 MiTek Industries, Inc. Thu Sep 12 02:47:56 2024 Page 2
ID:hFyjDMxrTsEK_kgkR0vWWVzFigc-RnXApPxzLsZvrB4f0notb_bnYpdmXio4_6QH_TyeVrH

NOTES-

- 12) No notches allowed in overhang and 0 from left end and 0 from right end or 12" along rake from scarf, whichever is larger. Minimum 1.5x4 tie plates required at 2-0-0 o.c. maximum between the stacking chords. For edge-wise notching, provide at least one tie plate between each notch.

WARNING - Verify design parameters and READ NOTES ON THIS AND INCLUDED MITEK REFERANCE PAGE MII-7473 rev. 6/30/2020 BEFORE USE.

Design valid for use only with MiTek® connectors. This design is based only upon parameters shown, and is for an individual building component, not a truss system. Before use, the building designer must verify the applicability of design parameters and properly incorporate this design into the overall building design. Bracing indicated is to prevent buckling of individual truss web and/or chord members only. Additional temporary and permanent bracing is always required for stability and to prevent collapse with possible personal injury and property damage. For general guidance regarding the fabrication, storage, delivery, erection and bracing of trusses and truss systems, see

Safety Information available from Truss Plate Institute, 2670 Crain Highway, Suite 203 Waldorf, MD 20601



240 Stirling Crescent
Bradford, ON. L3Z 4L5

Job	Truss	Truss Type	Qty	Ply	Buildings A-H	U1530774
N0653A	B1	GABLE	7	1		

Alliance Truss (CA), Abbotsford, BC - V2S 7P6, 8.630 s Jul 12 2024 MiTek Industries, Inc. Thu Sep 12 02:47:24 2024 Page 1

ID:hFyjDMxrTsEK_kgkR0vWWVzFfgc-RfC?PsB70Hq3NSgPqnL8w3ulTXbGKWrCDoi7J4zJC?F

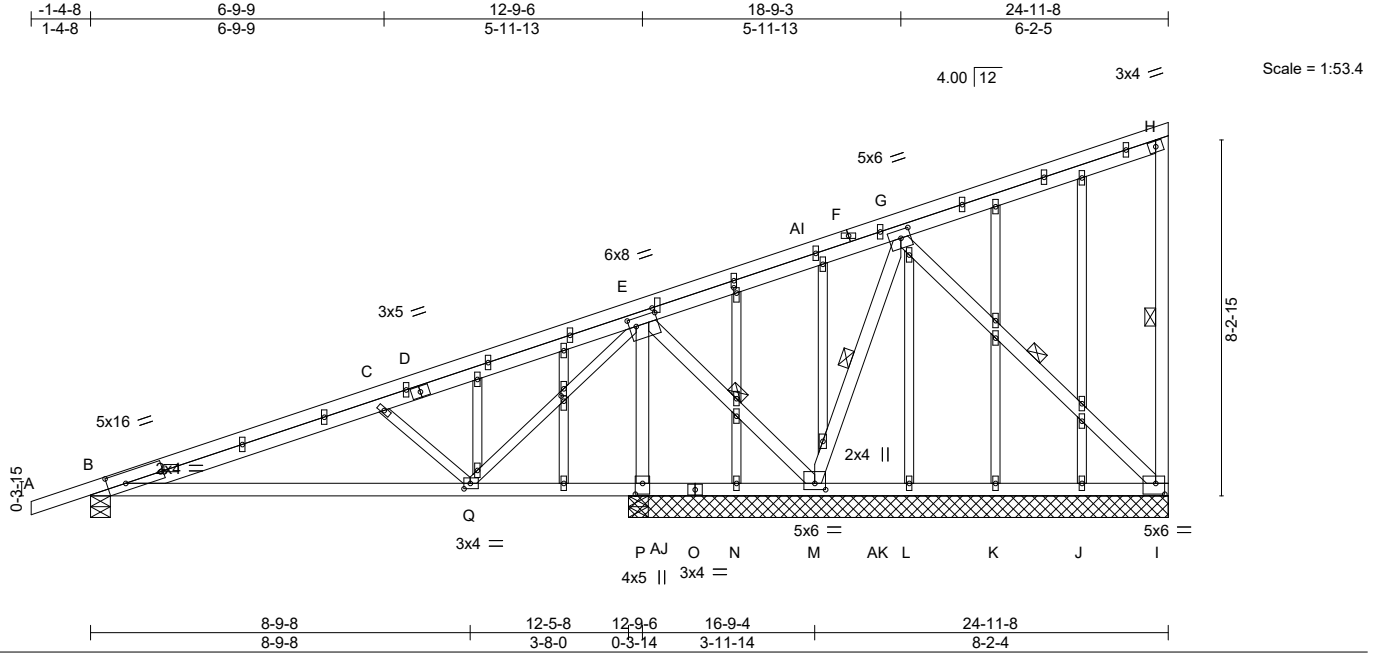

Plate Offsets (X,Y)-- [B:0-5-1,0-3-0], [E:0-1-14,0-2-4], [E:0-1-4,0-0-12], [G:0-2-12,0-2-4], [I:0-2-8,0-3-0], [M:0-3-0,0-1-12], [P:0-3-0,0-2-0], [Q:0-1-12,0-1-8], [Y:0-1-7,0-0-12], [AA:0-1-7,0-0-12], [AG:0-1-0,0-0-0]

LOADING (psf)	SPACING-	CSI.	DEFL.	in (loc)	l/defl	L/d	PLATES	GRIP
TCLL 25.0	2-0-0	TC 0.72	Vert(LL) -0.17	Q-AH	>877	360	MT20	197/144
(Roof Snow=25.0)	Plate Grip DOL 1.15	BC 0.73	Vert(CT) -0.32	Q-AH	>466	240		
TCDL 12.0	Lumber DOL 1.15	WB 0.91	Horz(CT) -0.05	J	n/a	n/a		
BCLL 0.0 *	Rep Stress Incr YES	Matrix-MS	Wind(LL) 0.10	Q-AH	>999	240	Weight: 158 lb	FT = 20%
BCDL 10.0	Code IBC2018/TPI2014							

LUMBER-	BRACING-
TOP CHORD 2x4 SPF No.2	TOP CHORD Structural wood sheathing directly applied or 3-5-15 oc purlins, except end verticals.
BOT CHORD 2x4 SPF No.2	BOT CHORD Rigid ceiling directly applied or 3-7-12 oc bracing.
WEBS 2x4 SPF No.2 *Except*	WEBS 1 Row at midpt H-I, E-M, G-M, G-I
C-Q,E-Q: 2x3 SPF No.2	
OTHERS 2x3 SPF No.2	

REACTIONS. All bearings 12-6-0 except (jt=length) B=0-5-8.
 (lb) - Max Horz B=618(LC 35)
 Max Uplift All uplift 100 lb or less at joint(s) J, K, L, N except I=1485(LC 35), B=-750(LC 32), P=-2877(LC 32)
 Max Grav All reactions 250 lb or less at joint(s) J, K, L, N except I=1484(LC 52), B=1165(LC 27), P=3277(LC 29), P=1257(LC 1)

FORCES. (lb) - Max. Comp./Max. Ten. - All forces 250 (lb) or less except when shown.
 TOP CHORD B-C=-2245/1859, C-E=-1537/1247, E-G=-1020/906, G-H=-1678/1585, H-I=-290/53
 BOT CHORD B-Q=-1911/2105, P-Q=-2060/1926, N-P=-1835/1714, M-N=-816/671, L-M=-2542/2482, K-L=-1494/1434, J-K=-629/582, I-J=-1517/1457
 WEBS C-Q=-573/193, E-Q=-164/965, E-M=-2921/3050, G-M=-2273/2225, G-I=-2018/2061, E-P=-3216/2858

- NOTES-**
- 1) Wind: ASCE 7-16; Vult=115mph (3-second gust) Vasd=91mph; TCDL=4.2psf; BCDL=5.0psf; h=30ft; Ke=1.00; Cat. II; Exp B; Enclosed; MWFRS (envelope) gable end zone; cantilever left and right exposed; end vertical left and right exposed; Lumber DOL=1.33 plate grip DOL=1.33
 - 2) Truss designed for wind loads in the plane of the truss only. For studs exposed to wind (normal to the face), see Standard Industry Gable End Details as applicable, or consult qualified building designer as per ANSI/TPI 1.
 - 3) TCLL: ASCE 7-16; Pf=25.0 psf (Lum DOL=1.15 Plate DOL=1.15); Is=1.0; Rough Cat B; Partially Exp.; Ce=1.0; Cs=1.00; Ct=1.10
 - 4) Unbalanced snow loads have been considered for this design.
 - 5) This truss has been designed for greater of min roof live load of 20.0 psf or 2.00 times flat roof load of 25.0 psf on overhangs non-concurrent with other live loads.
 - 6) All plates are 1.5x4 MT20 unless otherwise indicated.
 - 7) Gable studs spaced at 2-0-0 oc.
 - 8) This truss has been designed for a 10.0 psf bottom chord live load nonconcurrent with any other live loads.
 - 9) * This truss has been designed for a live load of 20.0psf on the bottom chord in all areas where a rectangle 3-6-0 tall by 2-0-0 wide will fit between the bottom chord and any other members, with BCDL = 10.0psf.
 - 10) Provide mechanical connection (by others) of truss to bearing plate capable of withstanding 100 lb uplift at joint(s) J, K, L, N except (jt=lb) I=1485, B=750, P=2877.
 - 11) This truss is designed in accordance with the 2018 International Building Code section 2306.1 and referenced standard ANSI/TPI 1.



September 12, 2024

Continued on page 2

WARNING - Verify design parameters and READ NOTES ON THIS AND INCLUDED MITEK REFERENCE PAGE MII-7473 rev. 6/30/2020 BEFORE USE.
 Design valid for use only with MiTek® connectors. This design is based only on parameters shown, and is for an individual building component, not a truss system. Before use, the building designer must verify the applicability of design parameters and properly incorporate this design into the overall building design. Bracing indicated is to prevent buckling of individual truss web and/or chord members only. Additional temporary and permanent bracing is always required for stability and to prevent collapse with possible personal injury and property damage. For general guidance regarding the fabrication, storage, delivery, erection and bracing of trusses and truss systems, see **ANSI/TPI1 Quality Criteria, DSB-89 and BCSI Building Component Safety Information** available from Truss Plate Institute, 2670 Crain Highway, Suite 203 Waldorf, MD 20601



Job	Truss	Truss Type	Qty	Ply	Buildings A-H
N0653A	B1	GABLE	7	1	U1530774

Alliance Truss (CA), Abbotsford, BC - V2S 7P6,

8.630 s Jul 12 2024 MiTek Industries, Inc. Thu Sep 12 02:47:24 2024 Page 2
 ID:hFyjDMxrTsEK_kgkR0vWWVzFigc-RfC?PsB70Hq3NSgPqnL8w3ulTXbGKWrCDoi7J4zJC?f

NOTES-

- 12) This truss has been designed for a total drag load of 240 plf. Lumber DOL=(1.33) Plate grip DOL=(1.33) Connect truss to resist drag loads along bottom chord from 12-5-8 to 24-11-8 for 479.2 plf.
- 13) No notches allowed in overhang and 10408 from left end and 0 from right end or 12" along rake from scarf, whichever is larger. Minimum 1.5x4 tie plates required at 2-0-0 o.c. maximum between the stacking chords. For edge-wise notching, provide at least one tie plate between each notch.

WARNING - Verify design parameters and READ NOTES ON THIS AND INCLUDED MITEK REFERENCE PAGE MII-7473 rev. 6/30/2020 BEFORE USE.

Design valid for use only with MiTek® connectors. This design is based only upon parameters shown, and is for an individual building component, not a truss system. Before use, the building designer must verify the applicability of design parameters and properly incorporate this design into the overall building design. Bracing indicated is to prevent buckling of individual truss web and/or chord members only. Additional temporary and permanent bracing is always required for stability and to prevent collapse with possible personal injury and property damage. For general guidance regarding the fabrication, storage, delivery, erection and bracing of trusses and truss systems, see

Safety Information available from Truss Plate Institute, 2670 Crain Highway, Suite 203 Waldorf, MD 20601



240 Stirling Crescent
 Bradford, ON. L3Z 4L5

Job N0653A	Truss B2	Truss Type Monopitch	Qty 28	Ply 1	Buildings A-H	U1530838
---------------	-------------	-------------------------	-----------	----------	---------------	----------

Alliance Truss (CA), Abbotsford, BC - V2S 7P6,

8.820 s Aug 30 2024 MiTek Industries, Inc. Thu Sep 12 02:48:03 2024 Page 1

ID:hFyjDMxrTsEK_kgkR0vWWVzFlgc-k7TqHo1Mi0SvBG6?wmQWNSO?me?Vgw56bic9jZyeVrA

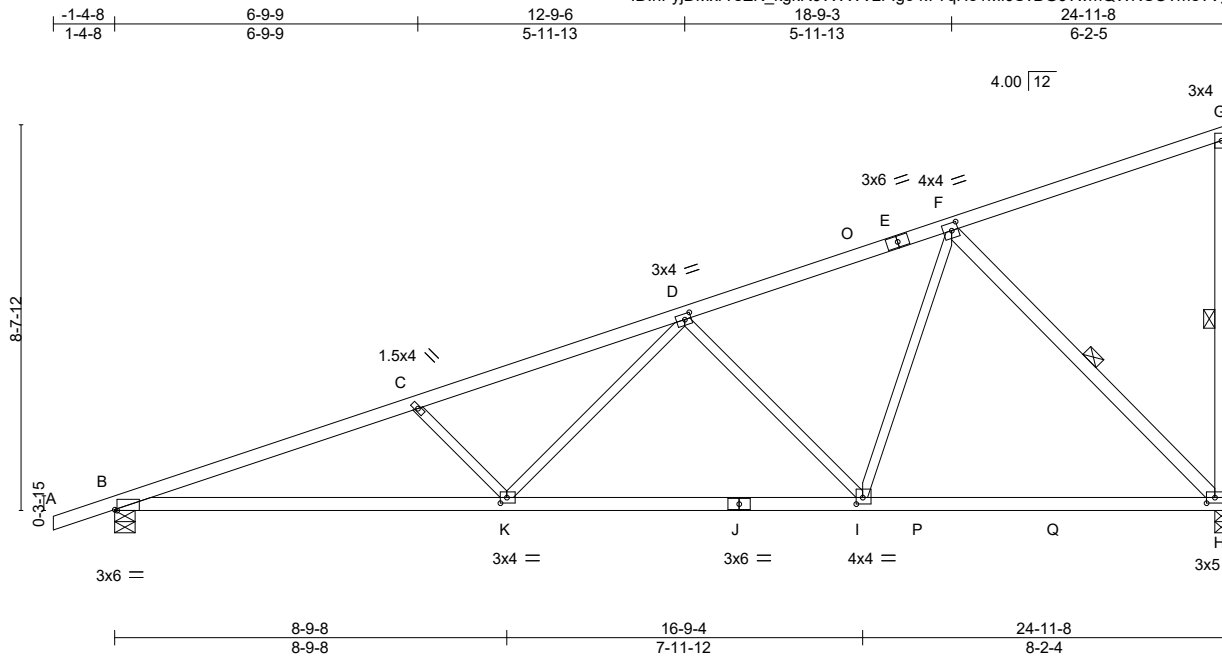

Plate Offsets (X,Y)-- [B:0-0-10,Edge], [D:0-1-12,0-1-8], [F:0-1-12,0-2-0], [G:0-2-0,0-1-4], [H:0-2-4,0-1-8], [I:0-1-12,0-1-12], [K:0-1-12,0-1-8]

LOADING (psf)	SPACING-	CSI.	DEFL.	PLATES	GRIP
TCLL 25.0 (Roof Snow=25.0)	2-0-0 Plate Grip DOL 1.15	TC 0.69	in (loc) l/defl L/d	MT20	197/144
TCDL 12.0	Lumber DOL 1.15	BC 0.84	Vert(LL) -0.20 K-N >999 360		
BCLL 0.0 *	Rep Stress Incr YES	WB 0.74	Vert(CT) -0.39 K-N >769 240		
BCDL 10.0	Code IBC2018/TPI2014	Matrix-MS	Horz(CT) 0.06 H n/a n/a		
			Wind(LL) 0.09 K-N >999 240	Weight: 96 lb	FT = 20%

LUMBER-

TOP CHORD 2x4 SPF No.2
 BOT CHORD 2x4 SPF No.2 *Except*
 B-J: 2x4 SPF 2100F 1.8E
 WEBS 2x3 SPF No.2 *Except*
 G-H,F-H: 2x4 SPF No.2

BRACING-

TOP CHORD Structural wood sheathing directly applied or 2-7-4 oc purlins, except end verticals.
 BOT CHORD Rigid ceiling directly applied or 10-0-0 oc bracing.
 WEBS 1 Row at midpt G-H, F-H

REACTIONS.

(size) H=0-3-8, B=0-5-8
 Max Horz B=281(LC 9)
 Max Uplift H=-167(LC 10), B=-172(LC 6)
 Max Grav H=1419(LC 3), B=1331(LC 3)

FORCES. (lb) - Max. Comp./Max. Ten. - All forces 250 (lb) or less except when shown.

TOP CHORD B-C=-2955/311, C-D=-2666/260, D-F=-1455/158, G-H=-283/51
 BOT CHORD B-K=-378/2775, I-K=-232/1883, H-I=-103/1036
 WEBS C-K=-516/161, D-K=-53/861, D-I=-849/185, F-I=-56/980, F-H=-1470/216

NOTES-

- 1) Wind: ASCE 7-16; Vult=115mph (3-second gust) Vasd=91mph; TCDL=4.2psf; BCDL=5.0psf; h=30ft; Ke=1.00; Cat. II; Exp B; Enclosed; MWFRS (envelope) gable end zone; cantilever left and right exposed ; end vertical left and right exposed; Lumber DOL=1.33 plate grip DOL=1.33
- 2) TCLL: ASCE 7-16; Pf=25.0 psf (Lum DOL = 1.15 Plate DOL = 1.15); Is=1.0; Rough Cat B; Partially Exp.; Ce=1.0; Cs=1.00; Ct=1.10
- 3) Unbalanced snow loads have been considered for this design.
- 4) This truss has been designed for greater of min roof live load of 20.0 psf or 2.00 times flat roof load of 25.0 psf on overhangs non-concurrent with other live loads.
- 5) This truss has been designed for a 10.0 psf bottom chord live load nonconcurrent with any other live loads.
- 6) * This truss has been designed for a live load of 20.0psf on the bottom chord in all areas where a rectangle 3-6-0 tall by 2-0-0 wide will fit between the bottom chord and any other members, with BCDL = 10.0psf.
- 7) Provide mechanical connection (by others) of truss to bearing plate capable of withstanding 167 lb uplift at joint H and 172 lb uplift at joint B.
- 8) This truss is designed in accordance with the 2018 International Building Code section 2306.1 and referenced standard ANSI/TPI 1.



September 12, 2024

WARNING - Verify design parameters and READ NOTES ON THIS AND INCLUDED MITEK REFERENCE PAGE MII-7473 rev. 6/30/2020 BEFORE USE.

Design valid for use only with MiTek® connectors. This design is based only upon parameters shown, and is for an individual building component, not a truss system. Before use, the building designer must verify the applicability of design parameters and properly incorporate this design into the overall building design. Bracing indicated is to prevent buckling of individual truss web and/or chord members only. Additional temporary and permanent bracing is always required for stability and to prevent collapse with possible personal injury and property damage. For general guidance regarding the fabrication, storage, delivery, erection and bracing of trusses and truss systems, see **ANSI/TPI1 Quality Criteria, DSB-89 and BCSI Building Component Safety Information** available from Truss Plate Institute, 2670 Crain Highway, Suite 203 Waldorf, MD 20601



240 Stirling Crescent
 Bradford, ON. L3Z 4L5

Job	Truss	Truss Type	Qty	Ply	Buildings A-H	U1530839
N0653A	B3	Roof Special	49	1		

Alliance Truss (CA), Abbotsford, BC - V2S 7P6, 8.820 s Aug 30 2024 MiTek Industries, Inc. Thu Sep 12 02:48:04 2024 Page 1
 ID:hFyjDMxrTsEK_kgkR0vWWVzFjgc-CK0CU82_TJampQhCUTxlvgwAI2JuPNeFqMMiG?yeVr9
 6-6-7 12-6-4 18-6-1 24-8-6
 6-6-7 5-11-13 5-11-13 6-2-5

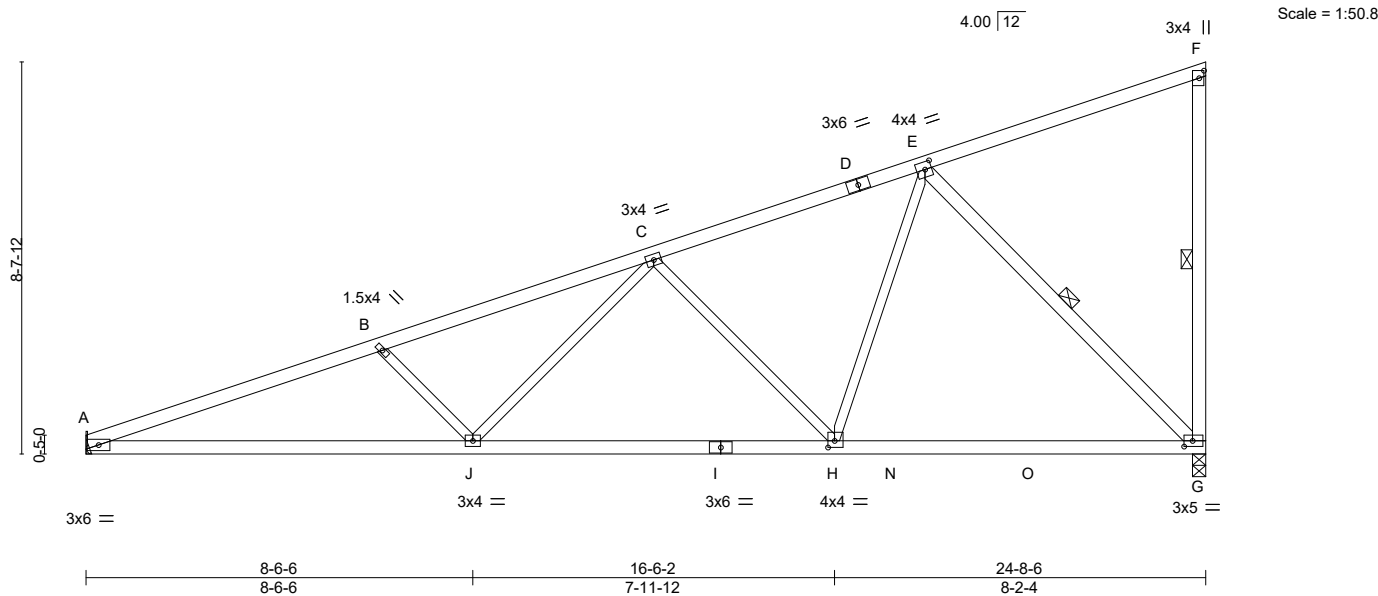

Plate Offsets (X,Y)-- [E:0-1-12,0-2-0], [F:0-2-0,0-1-4], [G:0-2-4,0-1-8], [H:0-1-12,0-1-12]

LOADING (psf)	SPACING-	CSI.	DEFL.	PLATES	GRIP
TCLL 25.0 (Roof Snow=25.0)	2-0-0 Plate Grip DOL 1.15 Lumber DOL 1.15	TC 0.67 BC 0.96 WB 0.72	in (loc) l/defl L/d Vert(LL) -0.20 G-H >999 360 Vert(CT) -0.34 G-H >873 240 Horz(CT) 0.07 G n/a n/a Wind(LL) 0.07 J-M >999 240	MT20	197/144
TCDL 12.0	Rep Stress Incr YES Code IBC2018/TPI2014	Matrix-MS		Weight: 93 lb	FT = 20%
BCLL 0.0 *					
BCDL 10.0					

LUMBER-

TOP CHORD 2x4 SPF No.2
 BOT CHORD 2x4 SPF No.2
 WEBS 2x3 SPF No.2 *Except*
 F-G,E-G: 2x4 SPF No.2

BRACING-

TOP CHORD Structural wood sheathing directly applied or 2-11-5 oc purlins, except end verticals.
 BOT CHORD Rigid ceiling directly applied or 2-2-0 oc bracing.
 WEBS 1 Row at midpt F-G, E-G

REACTIONS.

(size) G=0-3-8, A=Mechanical
 Max Horz A=272(LC 9)
 Max Uplift G=-167(LC 10), A=-125(LC 6)
 Max Grav G=1390(LC 3), A=1225(LC 3)

FORCES. (lb) - Max. Comp./Max. Ten. - All forces 250 (lb) or less except when shown.

TOP CHORD A-B=-2853/311, B-C=-2565/261, C-E=-1422/157, F-G=-281/51
 BOT CHORD A-J=-373/2660, H-J=-231/1832, G-H=-104/1009
 WEBS B-J=-488/159, C-J=-50/798, C-H=-827/184, E-H=-56/967, E-G=-1429/215

NOTES-

- 1) Wind: ASCE 7-16; Vult=115mph (3-second gust) Vasd=91mph; TCDL=4.2psf; BCDL=5.0psf; h=30ft; Ke=1.00; Cat. II; Exp B; Enclosed; MWFRS (envelope) gable end zone; cantilever left and right exposed; end vertical left and right exposed; Lumber DOL=1.33 plate grip DOL=1.33
- 2) TCLL: ASCE 7-16; Pf=25.0 psf (Lum DOL = 1.15 Plate DOL = 1.15); Is=1.0; Rough Cat B; Partially Exp.; Ce=1.0; Cs=1.00; Ct=1.10
- 3) Unbalanced snow loads have been considered for this design.
- 4) This truss has been designed for a 10.0 psf bottom chord live load nonconcurrent with any other live loads.
- 5) * This truss has been designed for a live load of 20.0psf on the bottom chord in all areas where a rectangle 3-6-0 tall by 2-0-0 wide will fit between the bottom chord and any other members, with BCDL = 10.0psf.
- 6) Refer to girder(s) for truss to truss connections.
- 7) Provide mechanical connection (by others) of truss to bearing plate capable of withstanding 167 lb uplift at joint G and 125 lb uplift at joint A.
- 8) This truss is designed in accordance with the 2018 International Building Code section 2306.1 and referenced standard ANSI/TPI 1.



September 12, 2024

WARNING - Verify design parameters and READ NOTES ON THIS AND INCLUDED MITEK REFERENCE PAGE MII-7473 rev. 6/30/2020 BEFORE USE.

Design valid for use only with MiTek® connectors. This design is based only upon parameters shown, and is for an individual building component, not a truss system. Before use, the building designer must verify the applicability of design parameters and properly incorporate this design into the overall building design. Bracing indicated is to prevent buckling of individual truss web and/or chord members only. Additional temporary and permanent bracing is always required for stability and to prevent collapse with possible personal injury and property damage. For general guidance regarding the fabrication, storage, delivery, erection and bracing of trusses and truss systems, see

Safety Information available from Truss Plate Institute, 2670 Crain Highway, Suite 203 Waldorf, MD 20601
ANSI/TPI1 Quality Criteria, DSB-89 and BCSI Building Component



240 Stirling Crescent
 Bradford, ON. L3Z 4L5

Job N0653A	Truss B3A	Truss Type ROOF SPECIAL	Qty 42	Ply 1	Buildings A-H Job Reference (optional)	U1530840
---------------	--------------	----------------------------	-----------	----------	---	----------

Alliance Truss (CA), Abbotsford, BC - V2S 7P6, 8.820 s Aug 30 2024 MiTek Industries, Inc. Thu Sep 12 02:48:04 2024 Page 1

ID:hFyjDMxrTsEK_kgkR0vWWWVzFigc-CK0CU82_TJampQhCUTxlvgw8U2KLPKBFqMMiG?yeVr9

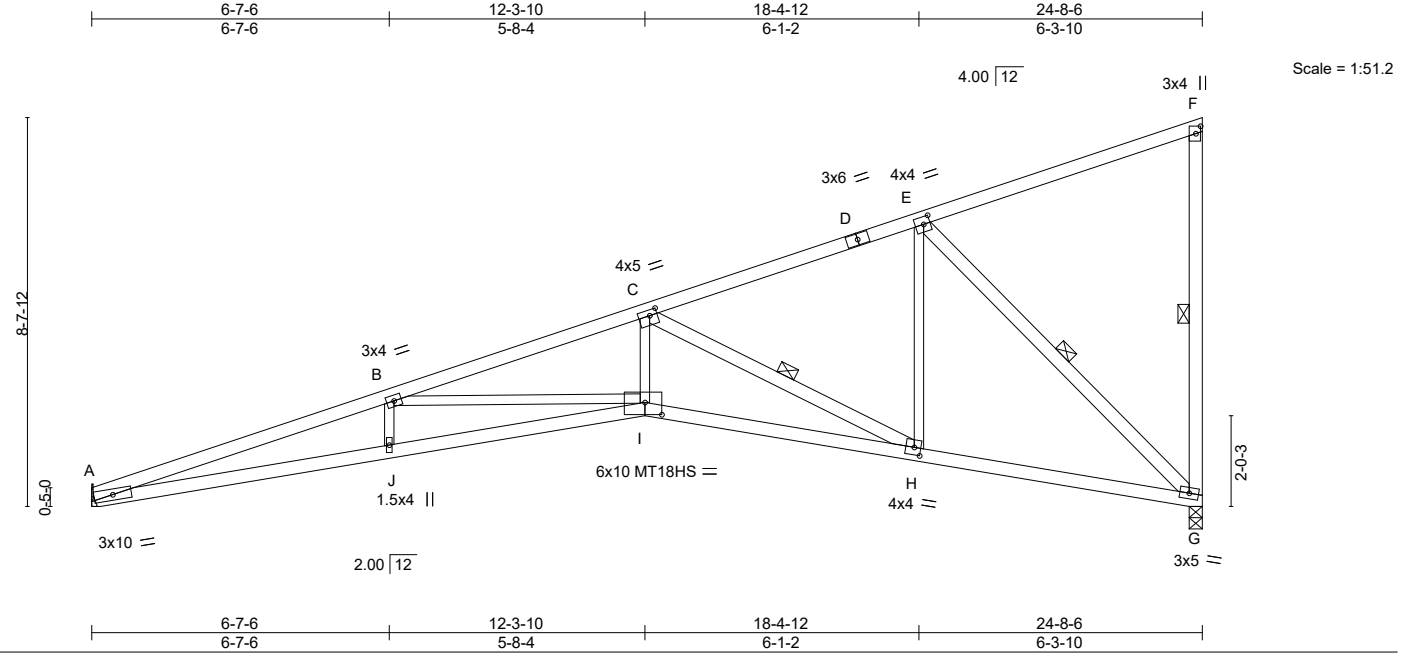

Plate Offsets (X,Y)-- [C:0-2-0,0-1-8], [E:0-1-12,0-2-0], [F:0-2-0,0-1-4], [H:0-1-12,0-2-0], [I:0-4-8,0-3-4]

LOADING (psf)	SPACING-	CSI.	DEFL.	PLATES	GRIP
TCLL 25.0 (Roof Snow=25.0)	2-0-0 Plate Grip DOL 1.15	TC 0.82	in (loc) l/defl L/d	MT20	197/144
TCDL 12.0	Lumber DOL 1.15	BC 0.93	Vert(LL) -0.41 I-J >710 360	MT18HS	197/144
BCLL 0.0 *	Rep Stress Incr YES	WB 0.94	Vert(CT) -0.76 I-J >386 240		
BCDL 10.0	Code IBC2018/TPI2014	Matrix-MS	Horz(CT) 0.34 G n/a n/a		
			Wind(LL) 0.24 I-J >999 240	Weight: 96 lb	FT = 20%

LUMBER-	BRACING-
TOP CHORD 2x4 SPF No.2	TOP CHORD Structural wood sheathing directly applied or 2-0-11 oc purlins, except end verticals.
BOT CHORD 2x4 SPF No.2 *Except*	BOT CHORD Rigid ceiling directly applied or 2-2-0 oc bracing.
WEBS 2x3 SPF No.2 *Except*	WEBS 1 Row at midpt F-G, C-H, E-G
F-G,C-H,E-G: 2x4 SPF No.2	

REACTIONS. (size) G=0-3-8, A=Mechanical
 Max Horz A=247(LC 6)
 Max Uplift G=-188(LC 6), A=-102(LC 6)
 Max Grav G=1380(LC 16), A=1195(LC 16)

FORCES. (lb) - Max. Comp./Max. Ten. - All forces 250 (lb) or less except when shown.
 TOP CHORD A-B=-4990/575, B-C=-3791/427, C-E=-1368/94, F-G=-286/64
 BOT CHORD A-J=-762/4729, I-J=-764/4739, H-I=-564/3595, G-H=-182/1267
 WEBS B-I=-1143/197, C-I=-178/1557, C-H=-2599/423, E-H=-63/968, E-G=-1747/249

- NOTES-**
- 1) Wind: ASCE 7-16; Vult=115mph (3-second gust) Vasd=91mph; TCDL=4.2psf; BCDL=5.0psf; h=30ft; Ke=1.00; Cat. II; Exp B; Enclosed; MWFRS (envelope) gable end zone; cantilever left exposed; end vertical left exposed; Lumber DOL=1.33 plate grip DOL=1.33
 - 2) TCLL: ASCE 7-16; Pf=25.0 psf (Lum DOL = 1.15 Plate DOL = 1.15); Is=1.0; Rough Cat B; Partially Exp.; Ce=1.0; Cs=1.00; Ct=1.10
 - 3) Unbalanced snow loads have been considered for this design.
 - 4) All plates are MT20 plates unless otherwise indicated.
 - 5) This truss has been designed for a 10.0 psf bottom chord live load nonconcurrent with any other live loads.
 - 6) * This truss has been designed for a live load of 20.0psf on the bottom chord in all areas where a rectangle 3-6-0 tall by 2-0-0 wide will fit between the bottom chord and any other members.
 - 7) Refer to girder(s) for truss to truss connections.
 - 8) Bearing at joint(s) G considers parallel to grain value using ANSI/TPI 1 angle to grain formula. Building designer should verify capacity of bearing surface.
 - 9) Provide mechanical connection (by others) of truss to bearing plate capable of withstanding 188 lb uplift at joint G and 102 lb uplift at joint A.
 - 10) This truss is designed in accordance with the 2018 International Building Code section 2306.1 and referenced standard ANSI/TPI 1.



September 12, 2024

Job N0653A	Truss B4	Truss Type GABLE	Qty 7	Ply 1	Buildings A-H U1530775
---------------	-------------	---------------------	----------	----------	---------------------------

Alliance Truss (CA), Abbotsford, BC - V2S 7P6, 8.630 s Jul 12 2024 MiTek Industries, Inc. Thu Sep 12 02:47:26 2024 Page 1

ID:hFyjDMxrTsEK_kgkR0vWWVzFfgc-RfC?PsB70Hq3NSgPqnL8w3ulTXbGKwRCDoi7J4zJC?F

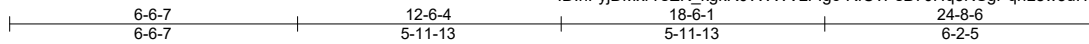

Scale = 1:52.3

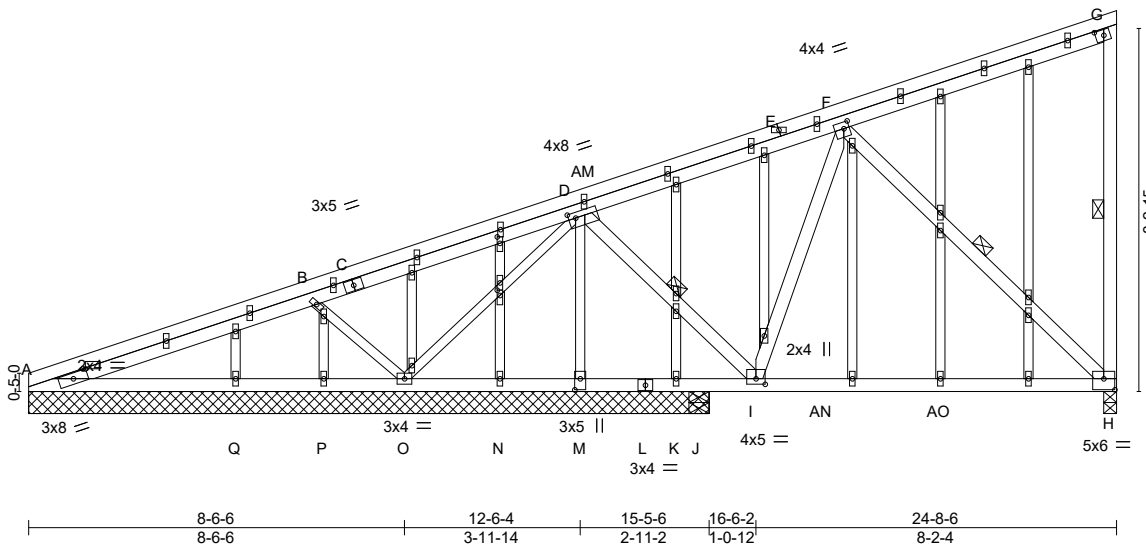

Plate Offsets (X,Y)-- [D:0-1-15,0-1-8], [F:0-1-8,0-1-12], [G:0-2-4,0-1-8], [H:0-3-0,0-3-0], [I:0-2-8,0-1-8], [M:0-3-0,0-1-8], [AD:0-1-7,0-0-12], [AE:0-1-12,0-0-12], [AK:0-0-12,0-0-0]

LOADING (psf)	SPACING-	CSI.	DEFL.	in (loc)	l/defl	L/d	PLATES	GRIP
TCLL 25.0 (Roof Snow=25.0)	2-0-0	TC 0.70	Vert(LL) -0.16	H-I	>712	360	MT20	197/144
TCDL 12.0	Plate Grip DOL 1.15	BC 0.79	Vert(CT) -0.27	H-I	>410	240		
BCLL 0.0 *	Lumber DOL 1.15	WB 0.96	Horz(CT) -0.02	H	n/a	n/a		
BCDL 10.0	Rep Stress Incr YES	Matrix-MS	Wind(LL) 0.06	O	>760	240	Weight: 156 lb	FT = 20%
	Code IBC2018/TPI2014							

LUMBER-	BRACING-
TOP CHORD 2x4 SPF No.2	TOP CHORD Structural wood sheathing directly applied or 2-2-0 oc purlins, except end verticals.
BOT CHORD 2x4 SPF No.2	BOT CHORD Rigid ceiling directly applied or 3-3-2 oc bracing.
WEBS 2x4 SPF No.2 *Except*	WEBS 1 Row at midpt G-H, D-I, F-H
B-O,D-O,D-M: 2x3 SPF No.2	
OTHERS 2x3 SPF No.2	

REACTIONS. All bearings 15-5-6 except (jt=length) H=0-3-8, J=0-5-8.
 (lb) - Max Horz A=315(LC 38)
 Max Uplift All uplift 100 lb or less at joint(s) K except H=919(LC 40), A=999(LC 31), N=320(LC 31), P=447(LC 31), Q=222(LC 54), M=1455(LC 31), J=315(LC 18)
 Max Grav All reactions 250 lb or less at joint(s) K, J except H=1330(LC 27), A=1099(LC 52), N=427(LC 28), P=487(LC 52), Q=350(LC 35), M=2167(LC 28), A=370(LC 1)

FORCES. (lb) - Max. Comp./Max. Ten. - All forces 250 (lb) or less except when shown.
 TOP CHORD A-B=-3149/2947, B-D=-1579/1391, D-F=-1946/1652, F-G=-1687/1587, G-H=-286/52
 BOT CHORD A-Q=-2497/2487, P-Q=-1260/1250, O-P=-547/664, N-O=-1003/917, M-N=-1702/1617, K-M=-2580/2491, J-K=-2780/2691, I-J=-2780/2691, H-I=-958/1023
 WEBS B-O=-589/250, D-O=-665/772, D-I=-1836/2119, F-I=-1378/1492, F-H=-1410/1308, D-M=-2255/1624

- NOTES-**
- 1) Wind: ASCE 7-16; Vult=115mph (3-second gust) Vasd=91mph; TCDL=4.2psf; BCDL=5.0psf; h=30ft; Ke=1.00; Cat. II; Exp B; Enclosed; MWFRS (envelope) gable end zone; cantilever left and right exposed ; end vertical left and right exposed; Lumber DOL=1.33 plate grip DOL=1.33
 - 2) Truss designed for wind loads in the plane of the truss only. For studs exposed to wind (normal to the face), see Standard Industry Gable End Details as applicable, or consult qualified building designer as per ANSI/TPI 1.
 - 3) TCLL: ASCE 7-16; Pf=25.0 psf (Lum DOL=1.15 Plate DOL=1.15); Is=1.0; Rough Cat B; Partially Exp.; Ce=1.0; Cs=1.00; Ct=1.10
 - 4) Unbalanced snow loads have been considered for this design.
 - 5) All plates are 1.5x4 MT20 unless otherwise indicated.
 - 6) Gable studs spaced at 2-0-0 oc.
 - 7) This truss has been designed for a 10.0 psf bottom chord live load nonconcurrent with any other live loads.
 - 8) * This truss has been designed for a live load of 20.0psf on the bottom chord in all areas where a rectangle 3-6-0 tall by 2-0-0 wide will fit between the bottom chord and any other members, with BCDL = 10.0psf.
 - 9) Provide mechanical connection (by others) of truss to bearing plate capable of withstanding 100 lb uplift at joint(s) K except (jt=lb) H=919, A=999, N=320, P=447, Q=222, M=1455, J=315, A=999.
 - 10) This truss is designed in accordance with the 2018 International Building Code section 2306.1 and referenced standard ANSI/TPI 1.



September 12, 2024

Continued on page 2

WARNING - Verify design parameters and READ NOTES ON THIS AND INCLUDED MITEK REFERENCE PAGE MII-7473 rev. 6/30/2020 BEFORE USE.

Design valid for use only with MiTek® connectors. This design is based only upon parameters shown, and is for an individual building component, not a truss system. Before use, the building designer must verify the applicability of design parameters and properly incorporate this design into the overall building design. Bracing indicated is to prevent buckling of individual truss web and/or chord members only. Additional temporary and permanent bracing is always required for stability and to prevent collapse with possible personal injury and property damage. For general guidance regarding the fabrication, storage, delivery, erection and bracing of trusses and truss systems, see **ANSI/TPI1 Quality Criteria, DSB-89 and BCSI Building Component Safety Information** available from Truss Plate Institute, 2670 Crain Highway, Suite 203 Waldorf, MD 20601



240 Stirling Crescent
Bradford, ON. L3Z 4L5

Job	Truss	Truss Type	Qty	Ply	Buildings A-H
N0653A	B4	GABLE	7	1	U1530775

Alliance Truss (CA), Abbotsford, BC - V2S 7P6,

8.630 s Jul 12 2024 MiTek Industries, Inc. Thu Sep 12 02:47:26 2024 Page 2
ID:hFyjDMxrTsEK_kgkR0vWWVzFigc-RfC?PsB70Hq3NSgPqnL8w3ulTXbGKWrCDoi7J4zJC?f**NOTES-**

- 11) This truss has been designed for a total drag load of 240 plf. Lumber DOL=(1.33) Plate grip DOL=(1.33) Connect truss to resist drag loads along bottom chord from 0-0-0 to 15-5-6 for 383.7 plf.
- 12) No notches allowed in overhang and 0 from left end and 0 from right end or 12" along rake from scarf, whichever is larger. Minimum 1.5x4 tie plates required at 2-0-0 o.c. maximum between the stacking chords. For edge-wise notching, provide at least one tie plate between each notch.



WARNING - Verify design parameters and READ NOTES ON THIS AND INCLUDED MITEK REFERENCE PAGE MII-7473 rev. 6/30/2020 BEFORE USE.

Design valid for use only with MiTek® connectors. This design is based only upon parameters shown, and is for an individual building component, not a truss system. Before use, the building designer must verify the applicability of design parameters and properly incorporate this design into the overall building design. Bracing indicated is to prevent buckling of individual truss web and/or chord members only. Additional temporary and permanent bracing is always required for stability and to prevent collapse with possible personal injury and property damage. For general guidance regarding the fabrication, storage, delivery, erection and bracing of trusses and truss systems, see

Safety Information available from Truss Plate Institute, 2670 Crain Highway, Suite 203 Waldorf, MD 20601



240 Stirling Crescent
Bradford, ON. L3Z 4L5

Job	Truss	Truss Type	Qty	Ply	Buildings A-H	U1530776
N0653A	C1	GABLE	15	1		

Alliance Truss (CA), Abbotsford, BC - V2S 7P6, 8.630 s Jul 12 2024 MiTek Industries, Inc. Thu Sep 12 02:47:26 2024 Page 1

ID:hFyjDMxrTsEK_kgkR0vWWVzFfgc-RfC?PsB70Hq3NSgPqnL8w3ulTXbGKWwCDoi7J4zJC?f

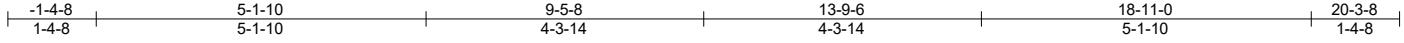

Scale = 1:35.9

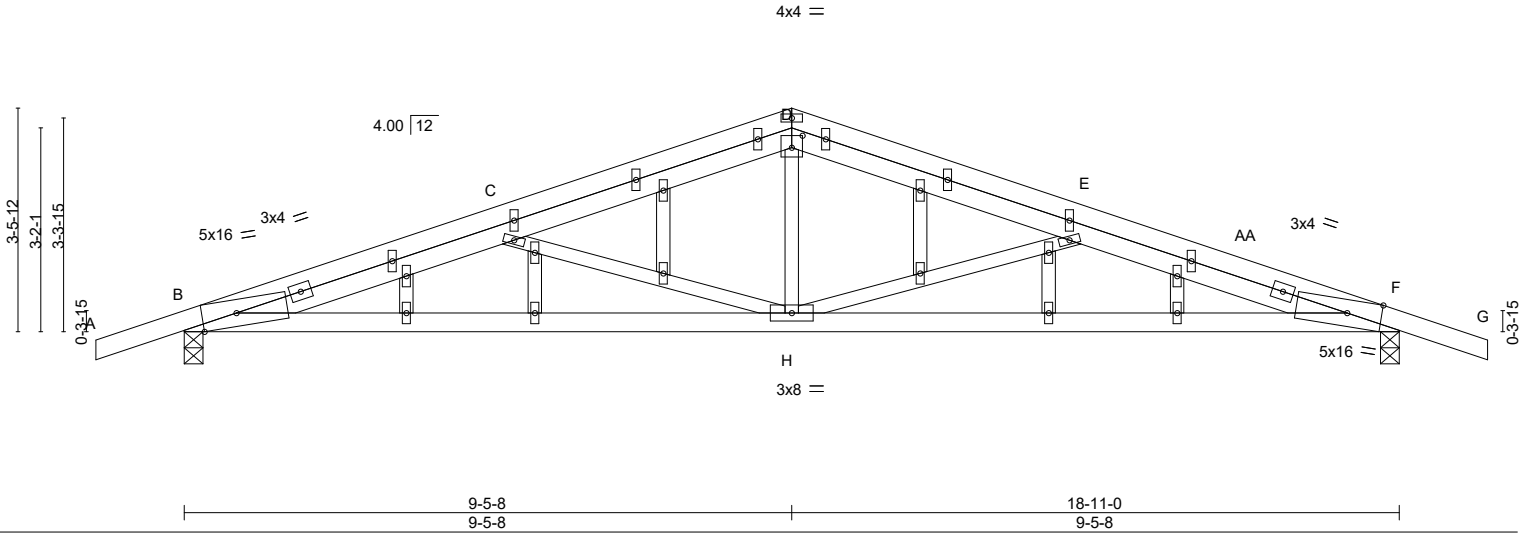

Plate Offsets (X,Y)-- [B:0-6-7,Edge], [D:0-2-0,0-2-4], [F:0-6-7,Edge]

LOADING (psf)	SPACING-	CSI.	DEFL.	PLATES	GRIP
TCLL 25.0 (Roof Snow=25.0)	2-0-0 Plate Grip DOL 1.15	TC 0.41	in (loc) l/defl L/d	MT20	197/144
TCDL 12.0	Lumber DOL 1.15	BC 0.81	Vert(LL) -0.14 H-Z >999 360		
BCLL 0.0 *	Rep Stress Incr YES	WB 0.55	Vert(CT) -0.33 H-W >684 240		
BCDL 10.0	Code IBC2018/TPI2014	Matrix-MS	Horz(CT) 0.06 F n/a n/a		
			Wind(LL) 0.06 H-W >999 240	Weight: 83 lb	FT = 20%

LUMBER-

TOP CHORD 2x4 SPF No.2
 BOT CHORD 2x4 SPF No.2
 WEBS 2x3 SPF No.2
 OTHERS 2x3 SPF No.2

BRACING-

TOP CHORD Structural wood sheathing directly applied or 3-3-12 oc purlins.
 BOT CHORD Rigid ceiling directly applied or 10-0-0 oc bracing.

REACTIONS.

(size) B=0-3-8, F=0-3-8
 Max Horz B=54(LC 10)
 Max Uplift B=-169(LC 6), F=-137(LC 7)
 Max Grav B=1105(LC 17), F=1057(LC 18)

FORCES. (lb) - Max. Comp./Max. Ten. - All forces 250 (lb) or less except when shown.

TOP CHORD B-C=-240/253, C-D=-1609/111, D-E=-1608/113, E-F=-253/243
 BOT CHORD B-H=-234/2275, F-H=-184/2396
 WEBS D-H=0/675, E-H=-1018/188, C-H=-932/197

NOTES-

- 1) Wind: ASCE 7-16; Vult=115mph (3-second gust) Vasd=91mph; TCDL=4.2psf; BCDL=5.0psf; h=30ft; Ke=1.00; Cat. II; Exp B; Enclosed; MWFRS (envelope) gable end zone; cantilever left and right exposed; end vertical left and right exposed; Lumber DOL=1.33 plate grip DOL=1.33
- 2) Truss designed for wind loads in the plane of the truss only. For studs exposed to wind (normal to the face), see Standard Industry Gable End Details as applicable, or consult qualified building designer as per ANSI/TPI 1.
- 3) TCLL: ASCE 7-16; Pf=25.0 psf (Lum DOL=1.15 Plate DOL=1.15); Is=1.0; Rough Cat B; Partially Exp.; Ce=1.0; Cs=1.00; Ct=1.10
- 4) Unbalanced snow loads have been considered for this design.
- 5) This truss has been designed for greater of min roof live load of 20.0 psf or 2.00 times flat roof load of 25.0 psf on overhangs non-concurrent with other live loads.
- 6) All plates are 1.5x4 MT20 unless otherwise indicated.
- 7) Gable studs spaced at 2-0-0 oc.
- 8) This truss has been designed for a 10.0 psf bottom chord live load nonconcurrent with any other live loads.
- 9) * This truss has been designed for a live load of 20.0psf on the bottom chord in all areas where a rectangle 3-6-0 tall by 2-0-0 wide will fit between the bottom chord and any other members.
- 10) Provide mechanical connection (by others) of truss to bearing plate capable of withstanding 100 lb uplift at joint(s) except (jt=lb) B=169, F=137.
- 11) This truss is designed in accordance with the 2018 International Building Code section 2306.1 and referenced standard ANSI/TPI 1.
- 12) No notches allowed in overhang and 10408 from left end and 10408 from right end or 12" along rake from scarf, whichever is larger. Minimum 1.5x4 tie plates required at 2-0-0 o.c. maximum between the stacking chords. For edge-wise notching, provide at least one tie plate between each notch.



September 12, 2024

WARNING - Verify design parameters and READ NOTES ON THIS AND INCLUDED MITEK REFERENCE PAGE MII-7473 rev. 6/30/2020 BEFORE USE.

Design valid for use only with MiTek® connectors. This design is based only upon parameters shown, and is for an individual building component, not a truss system. Before use, the building designer must verify the applicability of design parameters and properly incorporate this design into the overall building design. Bracing indicated is to prevent buckling of individual truss web and/or chord members only. Additional temporary and permanent bracing is always required for stability and to prevent collapse with possible personal injury and property damage. For general guidance regarding the fabrication, storage, delivery, erection and bracing of trusses and truss systems, see

Safety Information available from Truss Plate Institute, 2670 Crain Highway, Suite 203 Waldorf, MD 20601

ANSI/TPI1 Quality Criteria, DSB-89 and BCSI Building Component



240 Stirling Crescent
 Bradford, ON. L3Z 4L5

Job	Truss	Truss Type	Qty	Ply	Buildings A-H
N0653A	D1	GABLE	7	1	U1530777

Alliance Truss (CA), Abbotsford, BC - V2S 7P6,

8.630 s Jul 12 2024 MiTek Industries, Inc. Thu Sep 12 02:47:27 2024 Page 1

ID:hFyjDMxrTsEK_kgkR0vWWVzFgC-RfC?PsB70Hq3NSgPqnL8w3ulTXbGKWrCDoi7J4zJC?f

Job Reference (optional)

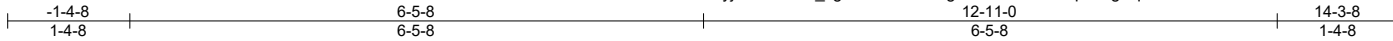

Scale = 1:25.9

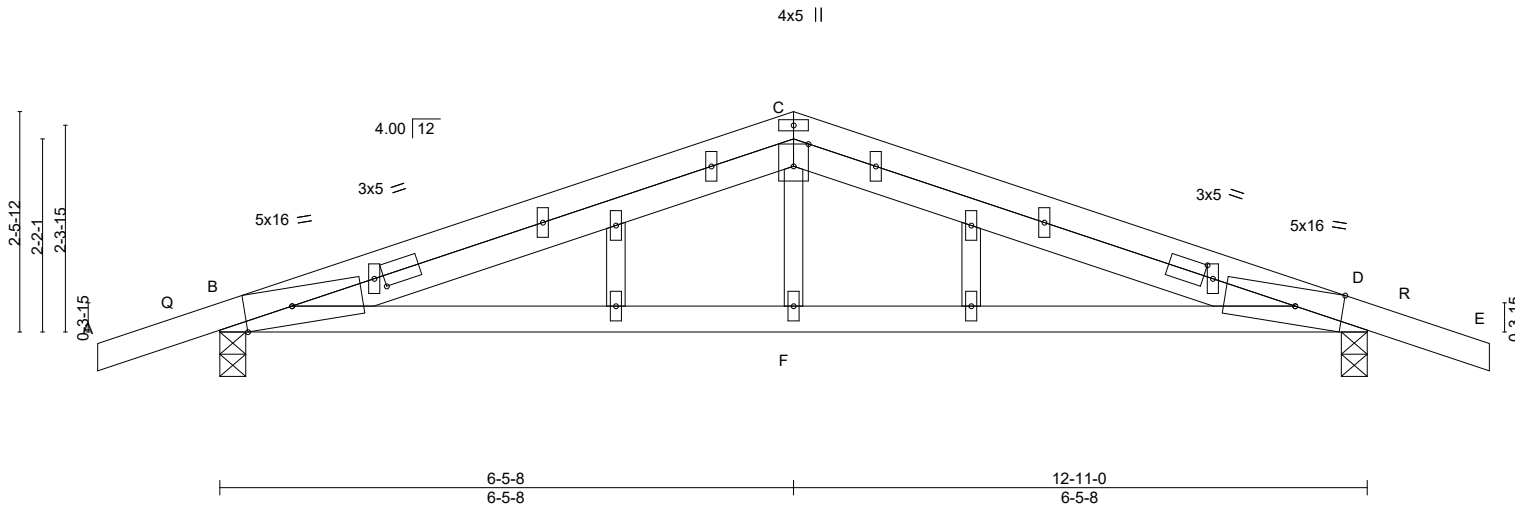

Plate Offsets (X,Y)-- [B:0-6-7,Edge], [B:1-1-0,0-1-8], [C:0-3-0,Edge], [D:1-1-0,0-1-8], [D:0-6-7,Edge]

LOADING (psf)	SPACING-	2-0-0	CSI.	DEFL.	in (loc)	l/defl	L/d	PLATES	GRIP
TCLL 25.0 (Roof Snow=25.0)	Plate Grip DOL 1.15		TC 0.86	Vert(LL) -0.11	F-M	>999	360	MT20	197/144
TCDL 12.0	Lumber DOL 1.15		BC 0.76	Vert(CT) -0.18	F-M	>864	240		
BCLL 0.0 *	Rep Stress Incr YES		WB 0.09	Horz(CT) 0.02	D	n/a	n/a		
BCDL 10.0	Code IBC2018/TPI2014		Matrix-MS	Wind(LL) 0.04	F-M	>999	240	Weight: 50 lb	FT = 20%

LUMBER-

TOP CHORD 2x4 SPF No.2
 BOT CHORD 2x4 SPF No.2
 WEBS 2x3 SPF No.2
 OTHERS 2x3 SPF No.2

BRACING-

TOP CHORD Structural wood sheathing directly applied or 2-2-0 oc purlins.
 BOT CHORD Rigid ceiling directly applied or 10-0-0 oc bracing.

REACTIONS.

(size) B=0-3-8, D=0-3-8
 Max Horz B=41(LC 10)
 Max Uplift B=-141(LC 6), D=-110(LC 7)
 Max Grav B=974(LC 17), D=822(LC 18)

FORCES. (lb) - Max. Comp./Max. Ten. - All forces 250 (lb) or less except when shown.

TOP CHORD B-C=-1260/86, C-D=-1230/91
 BOT CHORD B-F=-53/1118, D-F=-53/1118
 WEBS C-F=0/288

NOTES-

- 1) Wind: ASCE 7-16; Vult=115mph (3-second gust) Vasd=91mph; TCDL=4.2psf; BCDL=5.0psf; h=30ft; Ke=1.00; Cat. II; Exp B; Enclosed; MWFRS (envelope) gable end zone; cantilever left and right exposed; end vertical left and right exposed; Lumber DOL=1.33 plate grip DOL=1.33
- 2) Truss designed for wind loads in the plane of the truss only. For studs exposed to wind (normal to the face), see Standard Industry Gable End Details as applicable, or consult qualified building designer as per ANSI/TPI 1.
- 3) TCLL: ASCE 7-16; Pf=25.0 psf (Lum DOL=1.15 Plate DOL=1.15); Is=1.0; Rough Cat B; Partially Exp.; Ce=1.0; Cs=1.00; Ct=1.10
- 4) Unbalanced snow loads have been considered for this design.
- 5) This truss has been designed for greater of min roof live load of 20.0 psf or 2.00 times flat roof load of 25.0 psf on overhangs non-concurrent with other live loads.
- 6) All plates are 1.5x4 MT20 unless otherwise indicated.
- 7) Gable studs spaced at 2-0-0 oc.
- 8) This truss has been designed for a 10.0 psf bottom chord live load nonconcurrent with any other live loads.
- 9) * This truss has been designed for a live load of 20.0psf on the bottom chord in all areas where a rectangle 3-6-0 tall by 2-0-0 wide will fit between the bottom chord and any other members.
- 10) Provide mechanical connection (by others) of truss to bearing plate capable of withstanding 100 lb uplift at joint(s) except (jt=lb) B=141, D=110.
- 11) This truss is designed in accordance with the 2018 International Building Code section 2306.1 and referenced standard ANSI/TPI 1.
- 12) No notches allowed in overhang and 10408 from left end and 10408 from right end or 12" along rake from scarf, whichever is larger. Minimum 1.5x4 tie plates required at 2-0-0 o.c. maximum between the stacking chords. For edge-wise notching, provide at least one tie plate between each notch.



September 12, 2024

WARNING - Verify design parameters and READ NOTES ON THIS AND INCLUDED MITEK REFERENCE PAGE MII-7473 rev. 6/30/2020 BEFORE USE.

Design valid for use only with MiTek® connectors. This design is based only upon parameters shown, and is for an individual building component, not a truss system. Before use, the building designer must verify the applicability of design parameters and properly incorporate this design into the overall building design. Bracing indicated is to prevent buckling of individual truss web and/or chord members only. Additional temporary and permanent bracing is always required for stability and to prevent collapse with possible personal injury and property damage. For general guidance regarding the fabrication, storage, delivery, erection and bracing of trusses and truss systems, see

ANSI/TPI1 Quality Criteria, DSB-89 and BCSI Building Component

Safety Information available from Truss Plate Institute, 2670 Crain Highway, Suite 203 Waldorf, MD 20601



240 Stirling Crescent
 Bradford, ON. L3Z 4L5

Job	Truss	Truss Type	Qty	Ply	Buildings A-H	U1530841
N0653A	G1	GABLE	20	1		

Alliance Truss (CA), Abbotsford, BC - V2S 7P6,

8.820 s Aug 30 2024 MiTek Industries, Inc. Thu Sep 12 02:48:05 2024 Page 1

ID:hFyJDMxrTsEK_kgkR0vWWVzFlgc-gWaaIU2cEdidQaGO1AS_StTKARoq8_rO205FoSyeVr8

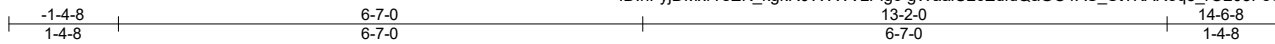

4x5 =

Scale = 1:28.9

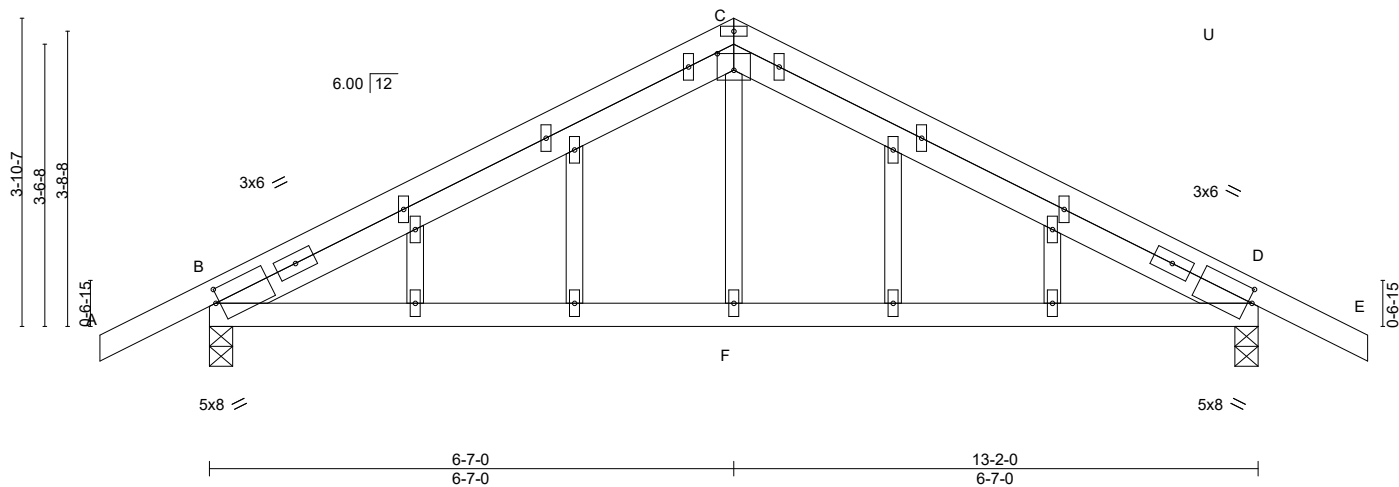

Plate Offsets (X,Y)-- [B:0-0-9,0-2-1], [C:0-2-8,0-2-8], [D:0-0-9,0-2-1]

LOADING (psf)	SPACING-	CSI.	DEFL.	in (loc)	l/defl	L/d	PLATES	GRIP
TCLL 25.0 (Roof Snow=25.0)	2-0-0 Plate Grip DOL 1.15 Lumber DOL 1.15	TC 0.76 BC 0.41 WB 0.08 Matrix-MS	Vert(LL) -0.07 Vert(CT) -0.10 Horz(CT) 0.01 Wind(LL) 0.03	F-T F-T B F-Q	>999 >999 n/a >999	360 240 n/a 240	MT20	197/144
TCDL 12.0	Rep Stress Incr YES Code IBC2018/TPI2014						Weight: 59 lb	FT = 20%
BCLL 0.0 *								
BCDL 10.0								

LUMBER-
 TOP CHORD 2x4 SPF No.2
 BOT CHORD 2x4 SPF No.2
 WEBS 2x3 SPF No.2
 OTHERS 2x3 SPF No.2

BRACING-
 TOP CHORD Structural wood sheathing directly applied or 4-4-14 oc purlins.
 BOT CHORD Rigid ceiling directly applied or 10-0-0 oc bracing.

REACTIONS. (size) B=0-3-8, D=0-3-8
 Max Horz B=52(LC 10)
 Max Uplift B=-90(LC 10), D=-78(LC 11)
 Max Grav B=760(LC 1), D=817(LC 18)

FORCES. (lb) - Max. Comp./Max. Ten. - All forces 250 (lb) or less except when shown.
 TOP CHORD B-C=-815/65, C-D=-877/66
 BOT CHORD B-F=-15/662, D-F=-15/662
 WEBS C-F=0/265

- NOTES-**
- 1) Wind: ASCE 7-16; Vult=115mph (3-second gust) Vasd=91mph; TCDL=4.2psf; BCDL=5.0psf; h=30ft; Ke=1.00; Cat. II; Exp B; Enclosed; MWFRS (envelope) gable end zone; cantilever left and right exposed; end vertical left and right exposed; Lumber DOL=1.33 plate grip DOL=1.33
 - 2) Truss designed for wind loads in the plane of the truss only. For studs exposed to wind (normal to the face), see Standard Industry Gable End Details as applicable, or consult qualified building designer as per ANSI/TPI 1.
 - 3) TLL: ASCE 7-16; Pf=25.0 psf (Lum DOL = 1.15 Plate DOL = 1.15); Is=1.0; Rough Cat B; Partially Exp.; Ce=1.0; Cs=1.00; Ct=1.10
 - 4) Unbalanced snow loads have been considered for this design.
 - 5) This truss has been designed for greater of min roof live load of 18.0 psf or 2.00 times flat roof load of 25.0 psf on overhangs non-concurrent with other live loads.
 - 6) All plates are 1.5x4 MT20 unless otherwise indicated.
 - 7) Gable studs spaced at 2-0-0 oc.
 - 8) This truss has been designed for a 10.0 psf bottom chord live load nonconcurrent with any other live loads.
 - 9) * This truss has been designed for a live load of 20.0psf on the bottom chord in all areas where a rectangle 3-6-0 tall by 2-0-0 wide will fit between the bottom chord and any other members.
 - 10) Provide mechanical connection (by others) of truss to bearing plate capable of withstanding 90 lb uplift at joint B and 78 lb uplift at joint D.
 - 11) This truss is designed in accordance with the 2018 International Building Code section 2306.1 and referenced standard ANSI/TPI 1.
 - 12) No notches allowed in overhang and 10408 from left end and 10408 from right end or 12" along rake from scarf, whichever is larger. Minimum 1.5x4 tie plates required at 2-0-0 o.c. maximum between the stacking chords. For edge-wise notching, provide at least one tie plate between each notch.



September 12, 2024

WARNING - Verify design parameters and READ NOTES ON THIS AND INCLUDED MITEK REFERENCE PAGE MII-7473 rev. 6/30/2020 BEFORE USE.

Design valid for use only with MiTek® connectors. This design is based only upon parameters shown, and is for an individual building component, not a truss system. Before use, the building designer must verify the applicability of design parameters and properly incorporate this design into the overall building design. Bracing indicated is to prevent buckling of individual truss web and/or chord members only. Additional temporary and permanent bracing is always required for stability and to prevent collapse with possible personal injury and property damage. For general guidance regarding the fabrication, storage, delivery, erection and bracing of trusses and truss systems, see

Safety Information available from Truss Plate Institute, 2670 Crain Highway, Suite 203 Waldorf, MD 20601



240 Stirling Crescent
 Bradford, ON. L3Z 4L5

Job	Truss	Truss Type	Qty	Ply	Buildings A-H	U1530778
N0653A	G2	Common	14	1		

Alliance Truss (CA), Abbotsford, BC - V2S 7P6,

8.630 s Jul 12 2024 MiTek Industries, Inc. Thu Sep 12 02:47:27 2024 Page 1

ID:hFyjDMxrTsEK_kgkR0vWWVzF1gc-RfC?PsB70Hq3NSgPqnL8w3ulTXbGKWrCDoi7J4zJC?f

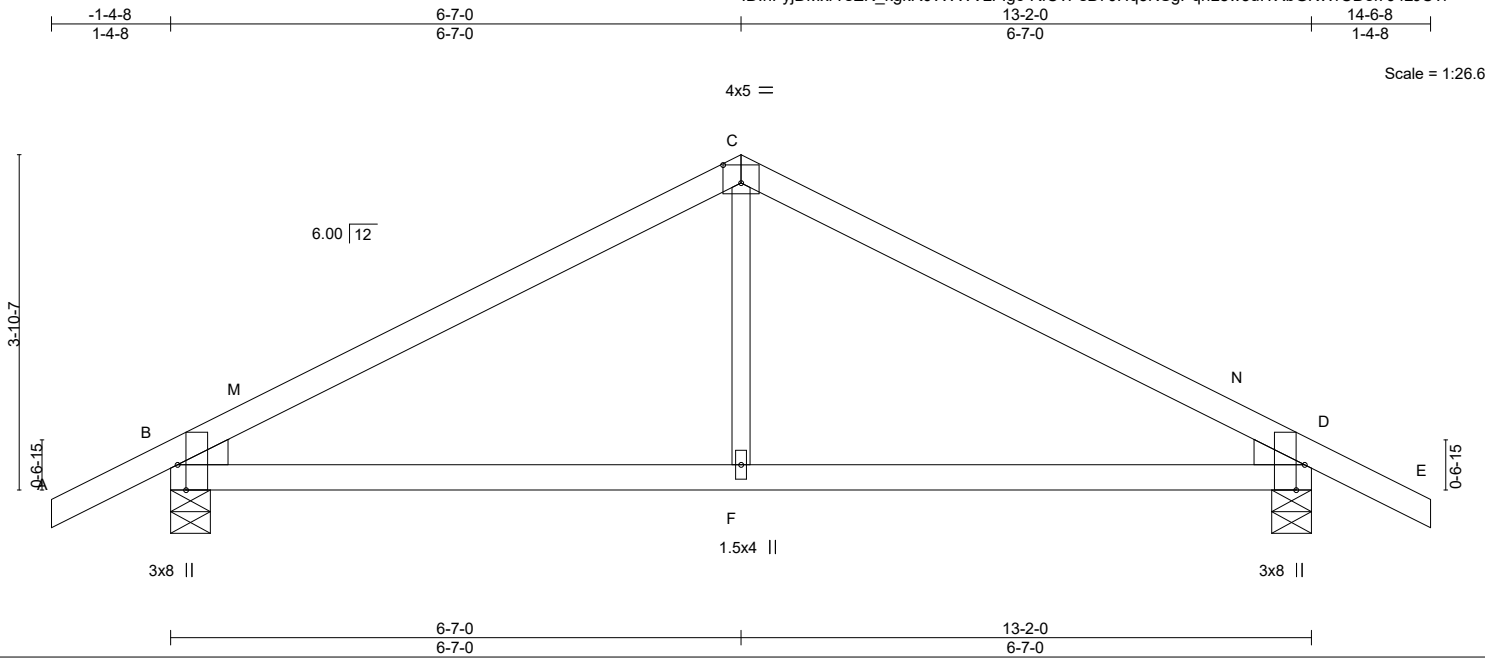

Plate Offsets (X,Y)-- [B:0-3-8,Edge], [C:0-2-8,0-2-8], [D:0-3-8,Edge]

LOADING (psf)	SPACING-	CSI.	DEFL.	in (loc)	l/defl	L/d	PLATES	GRIP
TCLL 25.0 (Roof Snow=25.0)	2-0-0 Plate Grip DOL 1.15	TC 0.79	Vert(LL)	-0.11	F-I	>999	MT20	197/144
TCDL 12.0	Lumber DOL 1.15	BC 0.61	Vert(CT)	-0.15	F-I	>999		
BCLL 0.0 *	Rep Stress Incr YES	WB 0.09	Horz(CT)	0.02	B	n/a		
BCDL 10.0	Code IBC2018/TPI2014	Matrix-MS	Wind(LL)	0.04	F-I	>999	Weight: 40 lb	FT = 20%

LUMBER-
 TOP CHORD 2x4 SPF No.2
 BOT CHORD 2x4 SPF No.2
 WEBS 2x3 SPF No.2
 WEDGE
 Left: 2x4 SPF No.2 , Right: 2x4 SPF No.2

BRACING-
 TOP CHORD Structural wood sheathing directly applied or 2-9-12 oc purlins.
 BOT CHORD Rigid ceiling directly applied or 10-0-0 oc bracing.

REACTIONS. (size) B=0-5-8, D=0-5-8
 Max Horz B=-52(LC 15)
 Max Uplift B=-75(LC 10), D=-75(LC 11)
 Max Grav B=817(LC 17), D=817(LC 18)

FORCES. (lb) - Max. Comp./Max. Ten. - All forces 250 (lb) or less except when shown.
 TOP CHORD B-C=-870/71, C-D=-870/71
 BOT CHORD B-F=-14/647, D-F=-14/647
 WEBS C-F=0/289

- NOTES-**
- 1) Wind: ASCE 7-16; Vult=115mph (3-second gust) Vasd=91mph; TCDL=4.2psf; BCDL=5.0psf; h=30ft; Ke=1.00; Cat. II; Exp B; Enclosed; MWFRS (envelope) gable end zone; cantilever left and right exposed ; end vertical left and right exposed; Lumber DOL=1.33 plate grip DOL=1.33
 - 2) TCLL: ASCE 7-16; Pf=25.0 psf (Lum DOL=1.15 Plate DOL=1.15); Is=1.0; Rough Cat B; Partially Exp.; Ce=1.0; Cs=1.00; Ct=1.10
 - 3) Unbalanced snow loads have been considered for this design.
 - 4) This truss has been designed for greater of min roof live load of 18.0 psf or 2.00 times flat roof load of 25.0 psf on overhangs non-concurrent with other live loads.
 - 5) This truss has been designed for a 10.0 psf bottom chord live load nonconcurrent with any other live loads.
 - 6) * This truss has been designed for a live load of 20.0psf on the bottom chord in all areas where a rectangle 3-6-0 tall by 2-0-0 wide will fit between the bottom chord and any other members.
 - 7) Provide mechanical connection (by others) of truss to bearing plate capable of withstanding 100 lb uplift at joint(s) B, D.
 - 8) This truss is designed in accordance with the 2018 International Building Code section 2306.1 and referenced standard ANSI/TPI 1.



September 12,2024

WARNING - Verify design parameters and READ NOTES ON THIS AND INCLUDED MITEK REFERENCE PAGE MII-7473 rev. 6/30/2020 BEFORE USE.
 Design valid for use only with MiTek® connectors. This design is based only upon parameters shown, and is for an individual building component, not a truss system. Before use, the building designer must verify the applicability of design parameters and properly incorporate this design into the overall building design. Bracing indicated is to prevent buckling of individual truss web and/or chord members only. Additional temporary and permanent bracing is always required for stability and to prevent collapse with possible personal injury and property damage. For general guidance regarding the fabrication, storage, delivery, erection and bracing of trusses and truss systems, see **ANSI/TPI1 Quality Criteria, DSB-89 and BCSI Building Component Safety Information** available from Truss Plate Institute, 2670 Crain Highway, Suite 203 Waldorf, MD 20601



240 Stirling Crescent
 Bradford, ON. L3Z 4L5

Job	Truss	Truss Type	Qty	Ply	Buildings A-H	U1530842
N0653A	G3	GABLE	2	1		

Alliance Truss (CA), Abbotsford, BC - V2S 7P6,

8.820 s Aug 30 2024 MiTek Industries, Inc. Thu Sep 12 02:48:05 2024 Page 1

ID:hFyjDMxrTsEK_kgkR0vWWVzFlgc-gWaaIU2cEdidQaGO1AS_StTSeRts8?BO205FoSyevr8

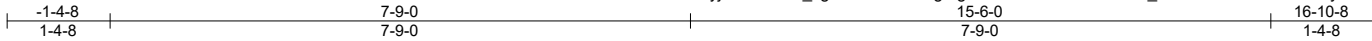

Scale = 1:30.8

4x4 =

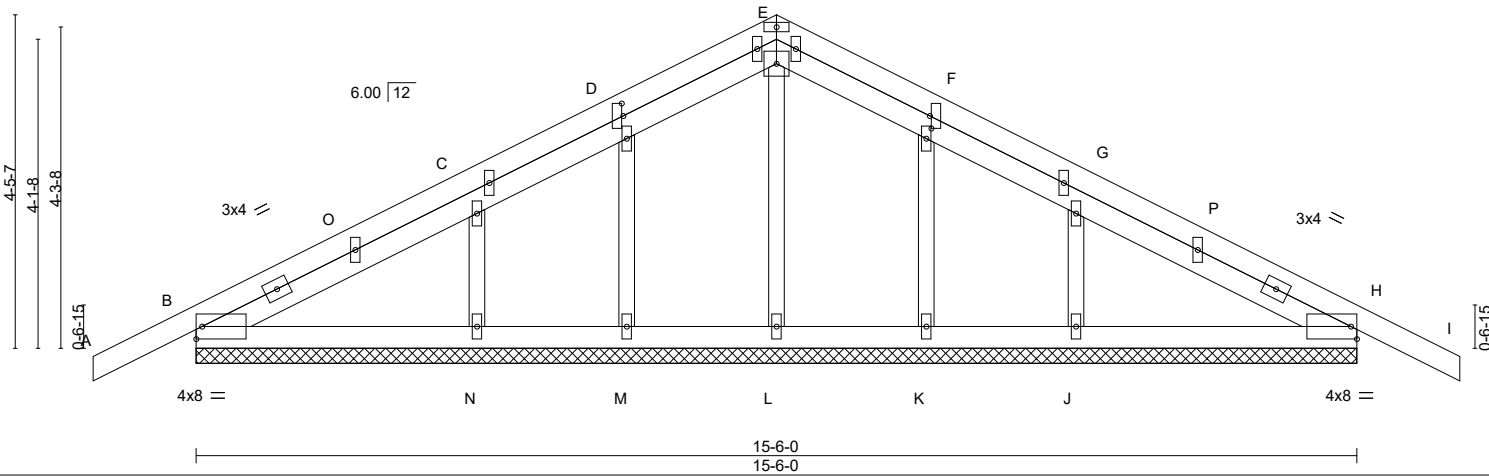

Plate Offsets (X,Y)-- [D:0-2-0,0-0-4], [F:0-2-0,0-0-4]

LOADING (psf)	SPACING-	CSI.	DEFL.	in (loc)	l/defl	L/d	PLATES	GRIP
TCLL 25.0 (Roof Snow=25.0)	2-0-0 Plate Grip DOL 1.15 Lumber DOL 1.15	TC 0.22 BC 0.08 WB 0.06 Matrix-S	Vert(LL) 0.00 Vert(CT) 0.00 Horz(CT) 0.00	H I H	n/r n/r n/a	120 90 n/a	MT20	197/144
TCDL 12.0	Rep Stress Incr YES Code IBC2018/TPI2014						Weight: 70 lb	FT = 20%
BCLL 0.0 *								
BCDL 10.0								

LUMBER-
 TOP CHORD 2x4 SPF No.2
 BOT CHORD 2x4 SPF No.2
 OTHERS 2x3 SPF No.2

BRACING-
 TOP CHORD Structural wood sheathing directly applied or 6-0-0 oc purlins.
 BOT CHORD Rigid ceiling directly applied or 10-0-0 oc bracing.

REACTIONS. All bearings 15-6-0.
 (lb) - Max Horz B=-55(LC 11)
 Max Uplift All uplift 100 lb or less at joint(s) B, H, M, N, K, J
 Max Grav All reactions 250 lb or less at joint(s) L, M, K except B=289(LC 17), H=289(LC 18), N=401(LC 17), J=400(LC 18)

FORCES. (lb) - Max. Comp./Max. Ten. - All forces 250 (lb) or less except when shown.
 WEBS C-N=-321/89, G-J=-320/90

- NOTES-**
- 1) Wind: ASCE 7-16; Vult=115mph (3-second gust) Vasd=91mph; TCDL=4.2psf; BCDL=5.0psf; h=30ft; Ke=1.00; Cat. II; Exp B; Enclosed; MWFRS (envelope) gable end zone; cantilever left and right exposed; end vertical left and right exposed; Lumber DOL=1.33 plate grip DOL=1.33
 - 2) Truss designed for wind loads in the plane of the truss only. For studs exposed to wind (normal to the face), see Standard Industry Gable End Details as applicable, or consult qualified building designer as per ANSI/TPI 1.
 - 3) TCLL: ASCE 7-16; Pf=25.0 psf (Lum DOL = 1.15 Plate DOL = 1.15); Is=1.0; Rough Cat B; Partially Exp.; Ce=1.0; Cs=1.00; Ct=1.10
 - 4) Unbalanced snow loads have been considered for this design.
 - 5) This truss has been designed for greater of min roof live load of 18.0 psf or 2.00 times flat roof load of 25.0 psf on overhangs non-concurrent with other live loads.
 - 6) All plates are 1.5x4 MT20 unless otherwise indicated.
 - 7) Gable requires continuous bottom chord bearing.
 - 8) Gable studs spaced at 2-0-0 oc.
 - 9) This truss has been designed for a 10.0 psf bottom chord live load nonconcurrent with any other live loads.
 - 10) * This truss has been designed for a live load of 20.0psf on the bottom chord in all areas where a rectangle 3-6-0 tall by 2-0-0 wide will fit between the bottom chord and any other members.
 - 11) Provide mechanical connection (by others) of truss to bearing plate capable of withstanding 100 lb uplift at joint(s) B, H, M, N, K, J.
 - 12) This truss is designed in accordance with the 2018 International Building Code section 2306.1 and referenced standard ANSI/TPI 1.
 - 13) No notches allowed in overhang and 10408 from left end and 10408 from right end or 12" along rake from scarf, whichever is larger. Minimum 1.5x4 tie plates required at 2-0-0 o.c. maximum between the stacking chords. For edge-wise notching, provide at least one tie plate between each notch.



September 12, 2024

WARNING - Verify design parameters and READ NOTES ON THIS AND INCLUDED MITEK REFERENCE PAGE MII-7473 rev. 6/30/2020 BEFORE USE.

Design valid for use only with MiTek® connectors. This design is based only upon parameters shown, and is for an individual building component, not a truss system. Before use, the building designer must verify the applicability of design parameters and properly incorporate this design into the overall building design. Bracing indicated is to prevent buckling of individual truss web and/or chord members only. Additional temporary and permanent bracing is always required for stability and to prevent collapse with possible personal injury and property damage. For general guidance regarding the fabrication, storage, delivery, erection and bracing of trusses and truss systems, see **ANSI/TPI1 Quality Criteria, DSB-89 and BCSI Building Component Safety Information** available from Truss Plate Institute, 2670 Crain Highway, Suite 203 Waldorf, MD 20601



240 Stirling Crescent
 Bradford, ON. L3Z 4L5

Job N0653A	Truss G4	Truss Type Common Girder	Qty 2	Ply 2	Buildings A-H Job Reference (optional)	U1530843
---------------	-------------	-----------------------------	----------	----------	---	----------

Alliance Truss (CA), Abbotsford, BC - V2S 7P6, 8.820 s Aug 30 2024 MiTek Industries, Inc. Thu Sep 12 02:48:06 2024 Page 1

ID:hFyjDMxrTsEK_kgkR0vWWVzFlgc-8i8yvq3F?xqU2krabuzD?50Y?r6ktDIYHgrpKuyeVr7

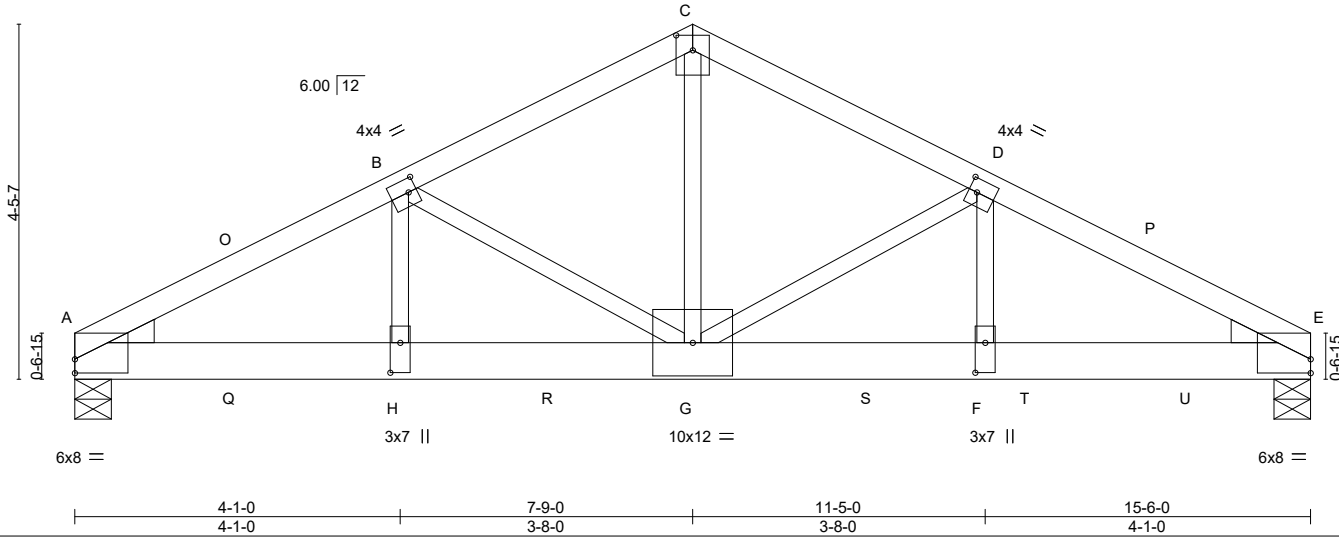
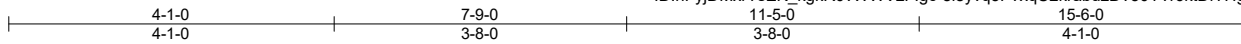

Plate Offsets (X,Y)-- [A:0-0-0,0-2-1], [B:0-1-4,0-2-0], [C:0-2-4,0-2-8], [D:0-1-4,0-2-0], [E:Edge,0-2-1], [F:0-4-8,0-1-8], [H:0-4-8,0-1-8]

LOADING (psf)	SPACING-	CSI.	DEFL.	PLATES	GRIP
TCLL 25.0 (Roof Snow=25.0)	2-0-0 Plate Grip DOL 1.15 Lumber DOL 1.15	TC 0.56 BC 0.55 WB 1.00 Matrix-MS	in (loc) l/defl L/d Vert(LL) -0.11 G-H >999 360 Vert(CT) -0.20 G-H >917 240 Horz(CT) 0.04 E n/a n/a Wind(LL) 0.06 G-H >999 240	MT20	197/144
TCDL 12.0	Rep Stress Incr NO			Weight: 124 lb	FT = 20%
BCLL 0.0 *	Code IBC2018/TPI2014				
BCDL 10.0					

LUMBER-
 TOP CHORD 2x4 SPF No.2
 BOT CHORD 2x6 SPF 2100F 1.8E
 WEBS 2x3 SPF No.2
 WEDGE
 Left: 2x4 SP No.3 , Right: 2x4 SP No.3

BRACING-
 TOP CHORD Structural wood sheathing directly applied or 3-7-5 oc purlins.
 BOT CHORD Rigid ceiling directly applied or 10-0-0 oc bracing.

REACTIONS. (size) A=0-5-8, E=0-5-8
 Max Horz A=51(LC 29)
 Max Uplift A=614(LC 10), E=649(LC 11)
 Max Grav A=5531(LC 3), E=5841(LC 4)

FORCES. (lb) - Max. Comp./Max. Ten. - All forces 250 (lb) or less except when shown.
 TOP CHORD A-B=-9488/1055, B-C=-6914/792, C-D=-6916/792, D-E=-9448/1051
 BOT CHORD A-H=-953/8416, G-H=-953/8416, F-G=-900/8388, E-F=-900/8388
 WEBS C-G=-638/5829, D-G=-2638/347, D-F=-222/2235, B-G=-2670/350, B-H=-228/2291

- NOTES-**
- 2-ply truss to be connected together with 10d (0.131"x3") nails as follows:
 Top chords connected as follows: 2x4 - 1 row at 0-4-0 oc.
 Bottom chords connected as follows: 2x6 - 2 rows staggered at 0-6-0 oc.
 Webs connected as follows: 2x3 - 1 row at 0-9-0 oc.
 - All loads are considered equally applied to all plies, except if noted as front (F) or back (B) face in the LOAD CASE(S) section. Ply to ply connections have been provided to distribute only loads noted as (F) or (B), unless otherwise indicated.
 - Wind: ASCE 7-16; Vult=115mph (3-second gust) Vasd=91mph; TCCL=4.2psf; BCDL=5.0psf; h=30ft; Ke=1.00; Cat. II; Exp B; Enclosed; MWFRS (envelope) gable end zone; cantilever left exposed ; end vertical left exposed; Lumber DOL=1.33 plate grip DOL=1.33
 - TCLL: ASCE 7-16; Pf=25.0 psf (Lum DOL = 1.15 Plate DOL = 1.15); Is=1.0; Rough Cat B; Partially Exp.; Ce=1.0; Cs=1.00; Ct=1.10
 - Unbalanced snow loads have been considered for this design.
 - This truss has been designed for a 10.0 psf bottom chord live load nonconcurrent with any other live loads.
 - * This truss has been designed for a live load of 20.0psf on the bottom chord in all areas where a rectangle 3-6-0 tall by 2-0-0 wide will fit between the bottom chord and any other members.
 - Provide mechanical connection (by others) of truss to bearing plate capable of withstanding 100 lb uplift at joint(s) except (jt=lb) A=614, E=649.
 - This truss is designed in accordance with the 2018 International Building Code section 2306.1 and referenced standard ANSI/TPI 1.
 - Hanger(s) or other connection device(s) shall be provided sufficient to support concentrated load(s) 1428 lb down and 174 lb up at 2-0-4, 1428 lb down and 174 lb up at 4-0-4, 1428 lb down and 174 lb up at 6-0-4, 1428 lb down and 174 lb up at 8-0-4, 1428 lb down and 174 lb up at 10-0-4, and 1428 lb down and 174 lb up at 12-0-4, and 1428 lb down and 174 lb up at 14-0-4 on bottom chord. The design/selection of such connection device(s) is the responsibility of others.

LOAD CASE(S) Standard
 Continued on page 2



September 12, 2024

WARNING - Verify design parameters and READ NOTES ON THIS AND INCLUDED MITEK REFERENCE PAGE MII-7473 rev. 6/30/2020 BEFORE USE.
 Design valid for use only with MiTek® connectors. This design is based only upon parameters shown, and is for an individual building component, not a truss system. Before use, the building designer must verify the applicability of design parameters and properly incorporate this design into the overall building design. Bracing indicated is to prevent buckling of individual truss web and/or chord members only. Additional temporary and permanent bracing is always required for stability and to prevent collapse with possible personal injury and property damage. For general guidance regarding the fabrication, storage, delivery, erection and bracing of trusses and truss systems, see **ANSI/TPI1 Quality Criteria, DSB-89 and BCSI Building Component Safety Information** available from Truss Plate Institute, 2670 Crain Highway, Suite 203 Waldorf, MD 20601



Job	Truss	Truss Type	Qty	Ply	Buildings A-H
N0653A	G4	Common Girder	2	2	U1530843

Alliance Truss (CA), Abbotsford, BC - V2S 7P6,

8.820 s Aug 30 2024 MiTek Industries, Inc. Thu Sep 12 02:48:06 2024 Page 2
 ID:hFyjDMxrTsEK_kgkR0vWWWzFIgc-8i8yvq3F?xqU2krabuzD?50Y?r6ktDIYHgrpKuyeVr7

LOAD CASE(S) Standard

1) Dead + Snow (balanced): Lumber Increase=1.15, Plate Increase=1.15

Uniform Loads (plf)

Vert: A-C=-74, C-E=-74, I-L=-20

Concentrated Loads (lb)

Vert: G=-1387(B) H=-1387(B) Q=-1387(B) R=-1387(B) S=-1387(B) T=-1387(B) U=-1387(B)

WARNING - Verify design parameters and READ NOTES ON THIS AND INCLUDED MITEK REFERENCE PAGE MII-7473 rev. 6/30/2020 BEFORE USE.

Design valid for use only with MiTek® connectors. This design is based only upon parameters shown, and is for an individual building component, not a truss system. Before use, the building designer must verify the applicability of design parameters and properly incorporate this design into the overall building design. Bracing indicated is to prevent buckling of individual truss web and/or chord members only. Additional temporary and permanent bracing is always required for stability and to prevent collapse with possible personal injury and property damage. For general guidance regarding the fabrication, storage, delivery, erection and bracing of trusses and truss systems, see

Safety Information available from Truss Plate Institute, 2670 Crain Highway, Suite 203 Waldorf, MD 20601



240 Stirling Crescent
 Bradford, ON. L3Z 4L5

Job N0653A	Truss H1	Truss Type GABLE	Qty 7	Ply 1	Buildings A-H Job Reference (optional)	U1530779
---------------	-------------	---------------------	----------	----------	---	----------

Alliance Truss (CA), Abbotsford, BC - V2S 7P6, 8.630 s Jul 12 2024 MiTek Industries, Inc. Thu Sep 12 02:47:29 2024 Page 1

ID:hFyjDMxrTsEK_kgkR0vWWVzFgC-RfC?PsB70Hq3NSgPqnL8w3ulTXbGKWrCDoi7J4zJC?f

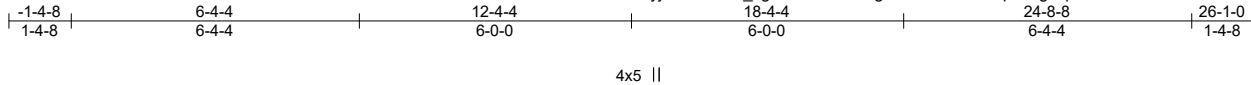

Scale = 1:50.8

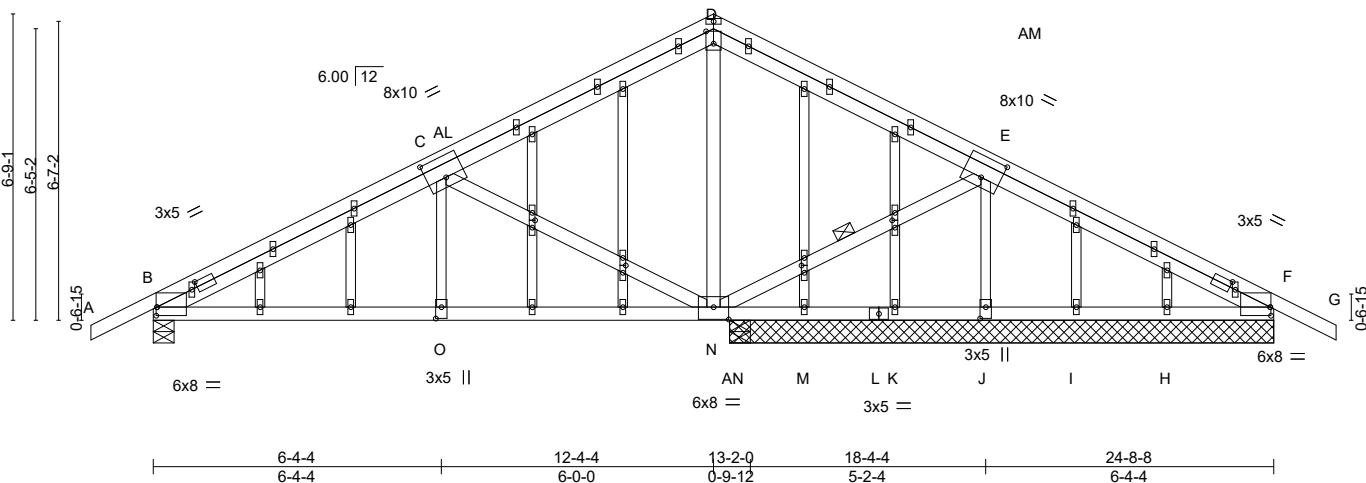

Plate Offsets (X,Y)-- [B:0-0-3,0-2-4], [B:0-11-15,0-1-8], [C:0-5-0,0-5-8], [D:0-3-4,0-2-0], [E:0-5-0,0-5-8], [F:0-11-15,0-1-8], [F:0-0-3,0-2-4], [J:0-3-0,0-1-8], [N:0-4-0,0-3-4], [O:0-3-0,0-1-8], [P:0-1-15,0-0-12], [S:0-1-15,0-0-12], [AA:0-1-15,0-0-12], [AC:0-1-15,0-0-12]

LOADING (psf)	SPACING-	CSI.	DEFL.	in (loc)	l/defl	L/d	PLATES	GRIP
TCLL 25.0 (Roof Snow=25.0)	2-0-0	TC 0.88	Vert(LL) -0.08	N-O	>999	360	MT20	197/144
TCDL 12.0	Plate Grip DOL 1.15	BC 0.66	Vert(CT) -0.09	O-AH	>999	240		
BCLL 0.0 *	Lumber DOL 1.15	WB 0.92	Horz(CT) 0.04	J	n/a	n/a		
BCDL 10.0	Rep Stress Incr YES	Matrix-MS	Wind(LL) 0.11	O-AH	>999	240	Weight: 139 lb	FT = 20%
	Code IBC2018/TPI2014							

LUMBER-
 TOP CHORD 2x4 SPF 2100F 1.8E *Except*
 B-D,D-F: 2x4 SPF No.2
 BOT CHORD 2x4 SPF 2100F 1.8E
 WEBS 2x4 SPF No.2 *Except*
 E-J,C-O: 2x3 SPF No.2
 OTHERS 2x3 SPF No.2

BRACING-
 TOP CHORD Structural wood sheathing directly applied or 2-11-6 oc purlins.
 BOT CHORD Rigid ceiling directly applied or 4-4-1 oc bracing.
 WEBS 1 Row at midpt E-N

REACTIONS. All bearings 12-0-0 except (jt=length) B=0-5-8.
 (lb) - Max Horz B=153(LC 49)
 Max Uplift All uplift 100 lb or less at joint(s) M except B=957(LC 40), N=1988(LC 40), J=1528(LC 43), I=111(LC 55), H=469(LC 42), F=1647(LC 43)
 Max Grav All reactions 250 lb or less at joint(s) M, K, I except B=1208(LC 29), N=2470(LC 29), N=1088(LC 1), J=1567(LC 38), H=533(LC 39), F=1690(LC 52), F=294(LC 1)

FORCES. (lb) - Max. Comp./Max. Ten. - All forces 250 (lb) or less except when shown.
 TOP CHORD B-C=2014/1784, C-D=1270/1422, D-E=2878/2936, E-F=3031/3017
 BOT CHORD B-O=1700/1900, N-O=1700/1900, M-N=3202/3239, K-M=2389/2423, J-K=1401/1438, I-J=560/597, H-I=1549/1585, F-H=2350/2387
 WEBS D-N=1405/1227, E-N=1655/1672, E-J=1556/1573, C-N=858/367, C-O=77/261

- NOTES-**
- 1) Wind: ASCE 7-16; Vult=115mph (3-second gust) Vasd=91mph; TCDL=4.2psf; BCDL=5.0psf; h=30ft; Ke=1.00; Cat. II; Exp B; Enclosed; MWFRS (envelope) gable end zone; cantilever left and right exposed; end vertical left and right exposed; Lumber DOL=1.33 plate grip DOL=1.33
 - 2) Truss designed for wind loads in the plane of the truss only. For studs exposed to wind (normal to the face), see Standard Industry Gable End Details as applicable, or consult qualified building designer as per ANSI/TPI 1.
 - 3) TCLL: ASCE 7-16; Pf=25.0 psf (Lum DOL=1.15 Plate DOL=1.15); Is=1.0; Rough Cat B; Partially Exp.; Ce=1.0; Cs=1.00; Ct=1.10
 - 4) Unbalanced snow loads have been considered for this design.
 - 5) This truss has been designed for greater of min roof live load of 18.0 psf or 2.00 times flat roof load of 25.0 psf on overhangs non-concurrent with other live loads.
 - 6) All plates are 1.5x4 MT20 unless otherwise indicated.
 - 7) Gable studs spaced at 2-0-0 oc.
 - 8) This truss has been designed for a 10.0 psf bottom chord live load nonconcurrent with any other live loads.
 - 9) * This truss has been designed for a live load of 20.0psf on the bottom chord in all areas where a rectangle 3-6-0 tall by 2-0-0 wide will fit between the bottom chord and any other members.
 - 10) Provide mechanical connection (by others) of truss to bearing plate capable of withstanding 100 lb uplift at joint(s) M except (jt=lb) B=957, N=1988, J=1528, I=111, H=469, F=1647, F=1647.
 - 11) This truss is designed in accordance with the 2018 International Building Code section 2306.1 and referenced standard ANSI/TPI



September 12, 2024

Continued on page 2

WARNING - Verify design parameters and READ NOTES ON THIS AND INCLUDED MITEK REFERENCE PAGE MII-7473 rev. 6/30/2020 BEFORE USE.

Design valid for use only with MiTek® connectors. This design is based only upon parameters shown, and is for an individual building component, not a truss system. Before use, the building designer must verify the applicability of design parameters and properly incorporate this design into the overall building design. Bracing indicated is to prevent buckling of individual truss web and/or chord members only. Additional temporary and permanent bracing is always required for stability and to prevent collapse with possible personal injury and property damage. For general guidance regarding the fabrication, storage, delivery, erection and bracing of trusses and truss systems, see

ANSI/TPI1 Quality Criteria, DSB-89 and BCSI Building Component

Safety Information available from Truss Plate Institute, 2670 Crain Highway, Suite 203 Waldorf, MD 20601



240 Stirling Crescent
 Bradford, ON. L3Z 4L5

Job	Truss	Truss Type	Qty	Ply	Buildings A-H
N0653A	H1	GABLE	7	1	U1530779

Alliance Truss (CA), Abbotsford, BC - V2S 7P6,

8.630 s Jul 12 2024 MiTek Industries, Inc. Thu Sep 12 02:47:29 2024 Page 2

ID:hFyjDMxrTsEK_kgkR0vWWVzFigc-RfC?PsB70Hq3NSgPqnL8w3ulTXbGKWrCDoi7J4zJC?f

NOTES-

- 12) This truss has been designed for a total drag load of 240 plf. Lumber DOL=(1.33) Plate grip DOL=(1.33) Connect truss to resist drag loads along bottom chord from 12-8-8 to 24-8-8 for 494.2 plf.
- 13) No notches allowed in overhang and 10408 from left end and 10408 from right end or 12" along rake from scarf, whichever is larger. Minimum 1.5x4 tie plates required at 2-0-0 o.c. maximum between the stacking chords. For edge-wise notching, provide at least one tie plate between each notch.

WARNING - Verify design parameters and READ NOTES ON THIS AND INCLUDED MITEK REFERENCE PAGE MII-7473 rev. 6/30/2020 BEFORE USE.

Design valid for use only with MiTek® connectors. This design is based only upon parameters shown, and is for an individual building component, not a truss system. Before use, the building designer must verify the applicability of design parameters and properly incorporate this design into the overall building design. Bracing indicated is to prevent buckling of individual truss web and/or chord members only. Additional temporary and permanent bracing is always required for stability and to prevent collapse with possible personal injury and property damage. For general guidance regarding the fabrication, storage, delivery, erection and bracing of trusses and truss systems, see

Safety Information available from Truss Plate Institute, 2670 Crain Highway, Suite 203 Waldorf, MD 20601

ANSI/TPI1 Quality Criteria, DSB-89 and BCSI Building Component



240 Stirling Crescent
Bradford, ON. L3Z 4L5

Job N0653A	Truss H2	Truss Type Common	Qty 7	Ply 1	Buildings A-H U1530780
---------------	-------------	----------------------	----------	----------	---------------------------

Alliance Truss (CA), Abbotsford, BC - V2S 7P6, 8.630 s Jul 12 2024 MiTek Industries, Inc. Thu Sep 12 02:47:29 2024 Page 1

ID:hFyjDMxrTsEK_kgkR0vWWVzFfgc-RfC?PsB70Hq3NSgPqnL8w3ulTXbGKWrCDoi7J4zJC?f

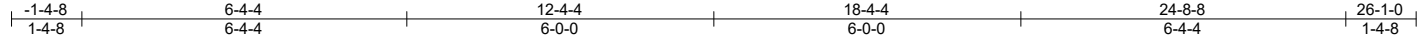

Scale = 1:45.0

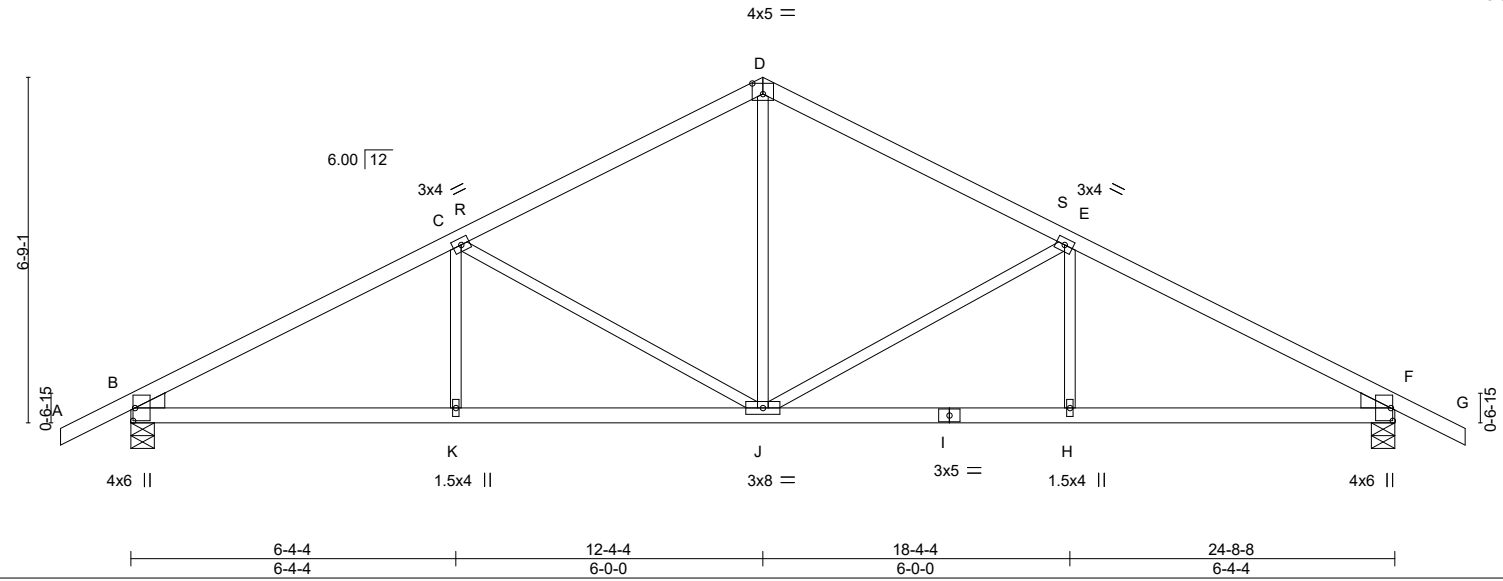

Plate Offsets (X,Y)-- [B:0-3-0,0-0-7], [D:0-2-8,0-2-8], [F:0-3-0,0-0-7]

LOADING (psf)	SPACING-	CSI.	DEFL.	PLATES	GRIP
TCLL 25.0 (Roof Snow=25.0)	2-0-0 Plate Grip DOL 1.15 Lumber DOL 1.15 Rep Stress Incr YES Code IBC2018/TPI2014	TC 0.81 BC 0.62 WB 0.83 Matrix-MS	in (loc) l/defl L/d Vert(LL) -0.09 J-K >999 360 Vert(CT) -0.17 J-K >999 240 Horz(CT) 0.06 F n/a n/a Wind(LL) 0.04 H-J >999 240	MT20	197/144
TCDL 12.0				Weight: 86 lb	FT = 20%
BCLL 0.0 *					
BCDL 10.0					

LUMBER-

TOP CHORD 2x4 SPF No.2
 BOT CHORD 2x4 SPF No.2
 WEBS 2x3 SPF No.2
 WEDGE
 Left: 2x4 SPF No.2, Right: 2x4 SPF No.2

BRACING-

TOP CHORD Structural wood sheathing directly applied or 2-2-0 oc purlins.
 BOT CHORD Rigid ceiling directly applied or 10-0-0 oc bracing.

REACTIONS.

(size) B=0-5-8, F=0-5-8
 Max Horz B=-90(LC 11)
 Max Uplift B=-119(LC 10), F=-119(LC 11)
 Max Grav B=1287(LC 17), F=1287(LC 18)

FORCES. (lb) - Max. Comp./Max. Ten. - All forces 250 (lb) or less except when shown.

TOP CHORD B-C=-1988/155, C-D=-1373/137, D-E=-1373/137, E-F=-1988/155
 BOT CHORD B-K=-152/1701, J-K=-152/1701, H-J=-62/1701, F-H=-62/1701
 WEBS D-J=-23/716, E-J=-705/149, C-J=-705/149

NOTES-

- 1) Wind: ASCE 7-16; Vult=115mph (3-second gust) Vasd=91mph; TCDL=4.2psf; BCDL=5.0psf; h=30ft; Ke=1.00; Cat. II; Exp B; Enclosed; MWFRS (envelope) gable end zone; cantilever left and right exposed; end vertical left and right exposed; Lumber DOL=1.33 plate grip DOL=1.33
- 2) TCLL: ASCE 7-16; Pf=25.0 psf (Lum DOL=1.15 Plate DOL=1.15); Is=1.0; Rough Cat B; Partially Exp.; Ce=1.0; Cs=1.00; Ct=1.10
- 3) Unbalanced snow loads have been considered for this design.
- 4) This truss has been designed for greater of min roof live load of 18.0 psf or 2.00 times flat roof load of 25.0 psf on overhangs non-concurrent with other live loads.
- 5) This truss has been designed for a 10.0 psf bottom chord live load nonconcurrent with any other live loads.
- 6) * This truss has been designed for a live load of 20.0psf on the bottom chord in all areas where a rectangle 3-6-0 tall by 2-0-0 wide will fit between the bottom chord and any other members.
- 7) Provide mechanical connection (by others) of truss to bearing plate capable of withstanding 100 lb uplift at joint(s) except (jt=lb) B=119, F=119.
- 8) This truss is designed in accordance with the 2018 International Building Code section 2306.1 and referenced standard ANSI/TPI 1.



September 12, 2024

WARNING - Verify design parameters and READ NOTES ON THIS AND INCLUDED MITEK REFERENCE PAGE MII-7473 rev. 6/30/2020 BEFORE USE.

Design valid for use only with MiTek® connectors. This design is based only upon parameters shown, and is for an individual building component, not a truss system. Before use, the building designer must verify the applicability of design parameters and properly incorporate this design into the overall building design. Bracing indicated is to prevent buckling of individual truss web and/or chord members only. Additional temporary and permanent bracing is always required for stability and to prevent collapse with possible personal injury and property damage. For general guidance regarding the fabrication, storage, delivery, erection and bracing of trusses and truss systems, see **ANSI/TPI1 Quality Criteria, DSB-89 and BCSI Building Component Safety Information** available from Truss Plate Institute, 2670 Crain Highway, Suite 203 Waldorf, MD 20601



240 Stirling Crescent
 Bradford, ON. L3Z 4L5

Job N0653A	Truss H3	Truss Type Common Girder	Qty 7	Ply 2	Buildings A-H U1530781
---------------	-------------	-----------------------------	----------	----------	---------------------------

Alliance Truss (CA), Abbotsford, BC - V2S 7P6, 8.630 s Jul 12 2024 MiTek Industries, Inc. Thu Sep 12 02:47:31 2024 Page 1

ID:hFyjDMxrTsEK_kgkR0vWWVzFlgc-RfC?PsB70Hq3NSgPqnL8w3ulTXbGKWrCDoi7J4zJC?F

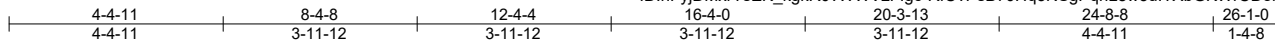

6x8 ||

Scale = 1:47.3

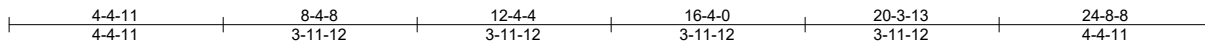
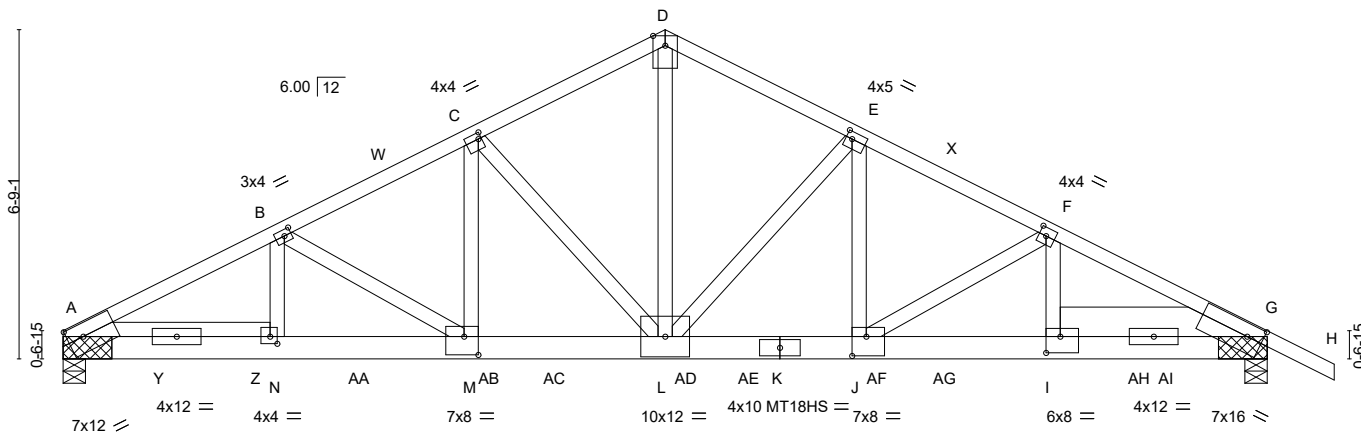

Plate Offsets (X,Y)-- [A:0-3-13,0-3-2], [B:0-1-12,0-1-8], [C:0-0-12,0-1-8], [E:0-1-8,0-1-12], [F:0-1-12,0-2-0], [G:0-3-13,0-3-2], [I:0-3-8,0-4-0], [J:0-3-8,0-4-12], [M:0-3-8,0-4-8], [N:0-1-12,0-1-12]

LOADING (psf)	SPACING-	CSI.	DEFL.	in (loc)	l/defl	L/d	PLATES	GRIP
TCLL 25.0 (Roof Snow=25.0)	2-0-0 Plate Grip DOL 1.15 Lumber DOL 1.15	TC 0.93 BC 0.63	Vert(LL) -0.21 Vert(CT) -0.39	L-M	>999	360	MT20	197/144
TCDL 12.0	Rep Stress Incr NO	WB 0.97	Horz(CT) 0.08	G	n/a	n/a	MT18HS	220/195
BCLL 0.0 *	Code IBC2018/TPI2014	Matrix-MS	Wind(LL) 0.11	L-M	>999	240		
BCDL 10.0							Weight: 302 lb	FT = 20%

LUMBER-

TOP CHORD 2x4 SPF No.2 *Except*
D-H: 2x4 SPF 2100F 1.8E
BOT CHORD 2x6 DF 2400F 2.0E
WEBS 2x4 SPF No.2
SLIDER Left 2x4 SPF No.2 3-10-0, Right 2x8 SPF 1950F 1.7E 3-10-0

BRACING-

TOP CHORD Structural wood sheathing directly applied or 2-1-4 oc purlins.
BOT CHORD Rigid ceiling directly applied or 10-0-0 oc bracing.

REACTIONS.

(size) A=(0-5-8 + bearing block) (req. 0-6-3), G=(0-5-8 + bearing block) (req. 0-6-13)
Max Horz A=-100(LC 15)
Max Uplift A=-865(LC 10), G=-971(LC 11)
Max Grav A=7891(LC 3), G=8683(LC 4)

FORCES. (lb) - Max. Comp./Max. Ten. - All forces 250 (lb) or less except when shown.

TOP CHORD A-B=-13476/1480, B-C=-11809/1305, C-D=-9158/1041, D-E=-9156/1042, E-F=-11891/1312, F-G=-14169/1551
BOT CHORD A-N=-987/8499, M-N=-1349/11987, L-M=-1139/10537, J-L=-1079/10604, I-J=-1326/12642, G-I=-855/8046
WEBS D-L=-861/7872, E-L=-3721/471, E-J=-381/3627, F-J=-2380/315, F-I=-223/2040, C-L=-3621/460, C-M=-368/3496, B-M=-1695/245, B-N=-156/1470

NOTES-

- 2-ply truss to be connected together with 10d (0.131"x3") nails as follows:
Top chords connected as follows: 2x4 - 1 row at 0-3-0 oc.
Bottom chords connected as follows: 2x6 - 2 rows staggered at 0-5-0 oc.
Webs connected as follows: 2x4 - 1 row at 0-9-0 oc.
- All loads are considered equally applied to all plies, except if noted as front (F) or back (B) face in the LOAD CASE(S) section. Ply to ply connections have been provided to distribute only loads noted as (F) or (B), unless otherwise indicated.
- 2x6 DF 2400F 2.0E bearing block 12" long at jt. A attached to each face with 3 rows of 10d (0.131"x3") nails spaced 3" o.c. 12 Total fasteners per block. Bearing is assumed to be SPF No.2.
- 2x6 DF 2400F 2.0E bearing block 12" long at jt. G attached to each face with 3 rows of 10d (0.131"x3") nails spaced 3" o.c. 12 Total fasteners per block. Bearing is assumed to be SPF No.2.
- Wind: ASCE 7-16; Vult=115mph (3-second gust) Vasd=91mph; TCDL=4.2psf; BCDL=5.0psf; h=30ft; Ke=1.00; Cat. II; Exp B; Enclosed; MWFRS (envelope) gable end zone; cantilever left and right exposed; end vertical left and right exposed; Lumber DOL=1.33 plate grip DOL=1.33
- TCLL: ASCE 7-16; Pf=25.0 psf (Lum DOL=1.15 Plate DOL=1.15); Is=1.0; Rough Cat B; Partially Exp.; Ce=1.0; Cs=1.00; Ct=1.10
- Unbalanced snow loads have been considered for this design.
- This truss has been designed for greater of min roof live load of 18.0 psf or 2.00 times flat roof load of 25.0 psf on overhangs non-concurrent with other live loads.
- All plates are MT20 plates unless otherwise indicated.
- This truss has been designed for a 10.0 psf bottom chord live load nonconcurrent with any other live loads.



September 12, 2024

Continued on page 2

WARNING - Verify design parameters and READ NOTES ON THIS AND INCLUDED MITEK REFERENCE PAGE MII-7473 rev. 6/30/2020 BEFORE USE.

Design valid for use only with MiTek® connectors. This design is based only upon parameters shown, and is for an individual building component, not a truss system. Before use, the building designer must verify the applicability of design parameters and properly incorporate this design into the overall building design. Bracing indicated is to prevent buckling of individual truss web and/or chord members only. Additional temporary and permanent bracing is always required for stability and to prevent collapse with possible personal injury and property damage. For general guidance regarding the fabrication, storage, delivery, erection and bracing of trusses and truss systems, see **ANSI/TPI1 Quality Criteria, DSB-89 and BCSI Building Component**

Safety Information available from Truss Plate Institute, 2670 Crain Highway, Suite 203 Waldorf, MD 20601



240 Stirling Crescent
Bradford, ON. L3Z 4L5

Job	Truss	Truss Type	Qty	Ply	Buildings A-H
N0653A	H3	Common Girder	7	2	U1530781

Alliance Truss (CA), Abbotsford, BC - V2S 7P6,

8.630 s Jul 12 2024 MiTek Industries, Inc. Thu Sep 12 02:47:31 2024 Page 2

ID:hFyjDMxrTsEK_kgkR0vWWVzFgc-RfC?PsB70Hq3NSgPqnL8w3ulTXbGKWrCDoi7J4zJC?f

NOTES-

- 11) * This truss has been designed for a live load of 20.0psf on the bottom chord in all areas where a rectangle 3-6-0 tall by 2-0-0 wide will fit between the bottom chord and any other members.
- 12) Provide mechanical connection (by others) of truss to bearing plate capable of withstanding 100 lb uplift at joint(s) except (jt=lb) A=865, G=971.
- 13) This truss is designed in accordance with the 2018 International Building Code section 2306.1 and referenced standard ANSI/TPI 1.
- 14) Hanger(s) or other connection device(s) shall be provided sufficient to support concentrated load(s) 1205 lb down and 145 lb up at 2-0-4, 1205 lb down and 145 lb up at 4-0-4, 1205 lb down and 145 lb up at 6-0-4, 1205 lb down and 145 lb up at 8-0-4, 1205 lb down and 145 lb up at 10-0-4, 1205 lb down and 145 lb up at 12-0-4, 1205 lb down and 145 lb up at 14-0-4, 1205 lb down and 145 lb up at 16-0-4, 1205 lb down and 145 lb up at 18-0-4, 1205 lb down and 145 lb up at 20-0-4, and 1205 lb down and 145 lb up at 22-0-4, and 1205 lb down and 145 lb up at 22-7-12 on bottom chord. The design/selection of such connection device(s) is the responsibility of others.

LOAD CASE(S) Standard

- 1) Dead + Snow (balanced): Lumber Increase=1.15, Plate Increase=1.15

Uniform Loads (plf)

Vert: A-D=-74, D-H=-74, O-S=-20

Concentrated Loads (lb)

Vert: I=-1175(F) Y=-1175(F) Z=-1175(F) AA=-1175(F) AB=-1175(F) AC=-1175(F) AD=-1175(F) AE=-1175(F) AF=-1175(F) AG=-1175(F) AH=-1175(F) AI=-1175(F)

WARNING - Verify design parameters and READ NOTES ON THIS AND INCLUDED MITEK REFERENCE PAGE MII-7473 rev. 6/30/2020 BEFORE USE.

Design valid for use only with MiTek® connectors. This design is based only upon parameters shown, and is for an individual building component, not a truss system. Before use, the building designer must verify the applicability of design parameters and properly incorporate this design into the overall building design. Bracing indicated is to prevent buckling of individual truss web and/or chord members only. Additional temporary and permanent bracing is always required for stability and to prevent collapse with possible personal injury and property damage. For general guidance regarding the fabrication, storage, delivery, erection and bracing of trusses and truss systems, see

Safety Information available from Truss Plate Institute, 2670 Crain Highway, Suite 203 Waldorf, MD 20601



240 Stirling Crescent
Bradford, ON. L3Z 4L5

Job	Truss	Truss Type	Qty	Ply	Buildings A-H	U1530844
N0653A	K1	GABLE	13	2		

Alliance Truss (CA), Abbotsford, BC - V2S 7P6, 8.820 s Aug 30 2024 MiTek Industries, Inc. Thu Sep 12 02:48:07 2024 Page 1

ID:hFyjDMxrTsEK_kgkR0vWWVzFfgc-cvIL6A4tmEyLguQm9bUSXIYiWfQXcjhWkaMsKyeVr6

4-7-2	8-9-5	12-4-4	13-2-0
4-7-2	4-2-3	3-6-15	0-9-12

Scale = 1:46.3

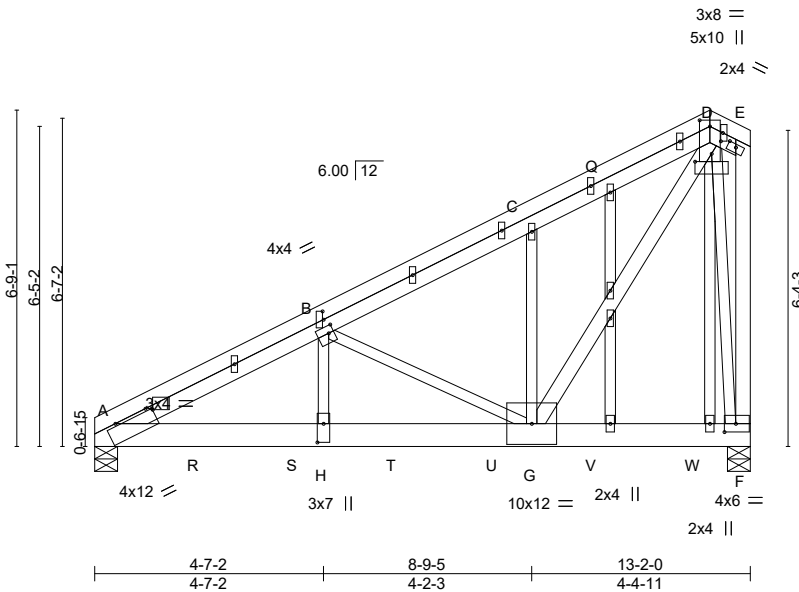

Plate Offsets (X,Y)-- [A:0-9-8,0-0-10], [B:0-1-4,0-1-12], [B:0-2-0,0-0-4], [D:0-4-0,0-1-15], [D:0-1-8,0-2-8], [D:0-2-0,0-0-8], [E:0-2-0,0-0-12], [F:0-2-12,0-2-0], [H:0-4-8,0-1-8], [O:0-1-12,0-0-4]

LOADING (psf)	SPACING-	CSI.	DEFL.	in (loc)	l/defl	L/d	PLATES	GRIP
TCLL 25.0	2-0-0	TC 0.58	Vert(LL)	-0.10	G-H	>999	MT20	197/144
(Roof Snow=25.0)	Plate Grip DOL 1.15	BC 0.58	Vert(CT)	-0.17	G-H	>878		
TCDL 12.0	Lumber DOL 1.15	WB 0.81	Horz(CT)	0.02	F	n/a		
BCLL 0.0 *	Rep Stress Incr NO	Matrix-MS	Wind(LL)	0.05	G-H	>999		
BCDL 10.0	Code IBC2018/TPI2014						Weight: 175 lb	FT = 20%

LUMBER-
 TOP CHORD 2x4 SPF No.2
 BOT CHORD 2x6 SPF 2100F 1.8E
 WEBS 2x3 SPF No.2 *Except*
 D-G,E-F: 2x4 SPF No.2
 OTHERS 2x3 SPF No.2

BRACING-
 TOP CHORD Structural wood sheathing directly applied or 3-11-13 oc purlins, except end verticals.
 BOT CHORD Rigid ceiling directly applied or 10-0-0 oc bracing.

REACTIONS. (size) A=0-5-8, F=0-5-8
 Max Horz A=176(LC 28)
 Max Uplift A=-532(LC 10), F=-630(LC 10)
 Max Grav A=4676(LC 3), F=5224(LC 3)

FORCES. (lb) - Max. Comp./Max. Ten. - All forces 250 (lb) or less except when shown.
 TOP CHORD A-B=-7751/879, B-C=-4320/502, C-D=-4340/566, E-F=-326/86
 BOT CHORD A-H=-861/7096, G-H=-862/7105, F-G=-99/451
 WEBS B-H=-270/2565, B-G=-3686/477, C-G=-331/119, D-G=-833/6615, D-F=-3640/457

- NOTES-**
- 2-ply truss to be connected together with 10d (0.131"x3") nails as follows:
 Top chords connected as follows: 2x4 - 1 row at 0-7-0 oc.
 Bottom chords connected as follows: 2x6 - 2 rows staggered at 0-5-0 oc.
 Webs connected as follows: 2x3 - 1 row at 0-9-0 oc, 2x4 - 1 row at 0-9-0 oc.
 - All loads are considered equally applied to all plies, except if noted as front (F) or back (B) face in the LOAD CASE(S) section. Ply to ply connections have been provided to distribute only loads noted as (F) or (B), unless otherwise indicated.
 - Wind: ASCE 7-16; Vult=115mph (3-second gust) Vasd=91mph; TCDL=4.2psf; BCDL=5.0psf; h=30ft; Ke=1.00; Cat. II; Exp B; Enclosed; MWFRS (envelope) gable end zone; cantilever left and right exposed; end vertical left and right exposed; Lumber DOL=1.33 plate grip DOL=1.33
 - Truss designed for wind loads in the plane of the truss only. For studs exposed to wind (normal to the face), see Standard Industry Gable End Details as applicable, or consult qualified building designer as per ANSI/TPI 1.
 - TCLL: ASCE 7-16; Pf=25.0 psf (Lum DOL = 1.15 Plate DOL = 1.15); ls=1.0; Rough Cat B; Partially Exp.; Ce=1.0; Cs=1.00; Ct=1.10
 - Unbalanced snow loads have been considered for this design.
 - All plates are 1.5x4 MT20 unless otherwise indicated.
 - Gable studs spaced at 2-0-0 oc.
 - This truss has been designed for a 10.0 psf bottom chord live load nonconcurrent with any other live loads.
 - * This truss has been designed for a live load of 20.0psf on the bottom chord in all areas where a rectangle 3-6-0 tall by 2-0-0 wide will fit between the bottom chord and any other members.
 - Provide mechanical connection (by others) of truss to bearing plate capable of withstanding 100 lb uplift at joint(s) except (jt=lb) A=532, F=630.
 - This truss is designed in accordance with the 2018 International Building Code section 2306.1 and referenced standard ANSI/TPI 1.



September 12, 2024

Continued on page 2

WARNING - Verify design parameters and READ NOTES ON THIS AND INCLUDED MITEK REFERENCE PAGE MII-7473 rev. 6/30/2020 BEFORE USE.

Design valid for use only with MiTek® connectors. This design is based only upon parameters shown, and is for an individual building component, not a truss system. Before use, the building designer must verify the applicability of design parameters and properly incorporate this design into the overall building design. Bracing indicated is to prevent buckling of individual truss web and/or chord members only. Additional temporary and permanent bracing is always required for stability and to prevent collapse with possible personal injury and property damage. For general guidance regarding the fabrication, storage, delivery, erection and bracing of trusses and truss systems, see **ANSI/TPI1 Quality Criteria, DSB-89 and BCSI Building Component Safety Information** available from Truss Plate Institute, 2670 Crain Highway, Suite 203 Waldorf, MD 20601



240 Stirling Crescent
 Bradford, ON. L3Z 4L5

Job	Truss	Truss Type	Qty	Ply	Buildings A-H
N0653A	K1	GABLE	13	2	U1530844

Alliance Truss (CA), Abbotsford, BC - V2S 7P6,

8.820 s Aug 30 2024 MiTek Industries, Inc. Thu Sep 12 02:48:07 2024 Page 2
ID:hFyjDMxrTsEK_kgkR0vWWVzFlgc-cvIL6A4tmEyLguQm9bUSXIYiWfQXcjhWkaMsKyeVr6**NOTES-**

- 13) Hanger(s) or other connection device(s) shall be provided sufficient to support concentrated load(s) 1476 lb down and 180 lb up at 2-0-4, 1476 lb down and 180 lb up at 4-0-4, 1476 lb down and 180 lb up at 6-0-4, 1476 lb down and 180 lb up at 8-0-4, and 1476 lb down and 180 lb up at 10-0-4, and 1476 lb down and 180 lb up at 12-0-4 on bottom chord. The design/selection of such connection device(s) is the responsibility of others.
- 14) No notches allowed in overhang and 0-0-0 from left end and 0-0-0 from right end or 12" along rake from scarf, whichever is larger. Minimum 1.5x4 tie plates required at 2-0-0 o.c. maximum between the stacking chords. For edge-wise notching, provide at least one tie plate between each notch.
- 15) Studding applied to ply: 1(Front)

LOAD CASE(S) Standard

1) Dead + Snow (balanced): Lumber Increase=1.15, Plate Increase=1.15

Uniform Loads (plf)

Vert: A-D=-74, D-E=-74, F-N=-20

Concentrated Loads (lb)

Vert: R=-1434(F) S=-1434(F) T=-1434(F) U=-1434(F) V=-1434(F) W=-1434(F)

WARNING - Verify design parameters and READ NOTES ON THIS AND INCLUDED MITEK REFERENCE PAGE MII-7473 rev. 6/30/2020 BEFORE USE.

Design valid for use only with MiTek® connectors. This design is based only upon parameters shown, and is for an individual building component, not a truss system. Before use, the building designer must verify the applicability of design parameters and properly incorporate this design into the overall building design. Bracing indicated is to prevent buckling of individual truss web and/or chord members only. Additional temporary and permanent bracing is always required for stability and to prevent collapse with possible personal injury and property damage. For general guidance regarding the fabrication, storage, delivery, erection and bracing of trusses and truss systems, see

Safety Information available from Truss Plate Institute, 2670 Crain Highway, Suite 203 Waldorf, MD 20601

ANSI/TPI1 Quality Criteria, DSB-89 and BCSI Building Component



240 Stirling Crescent
Bradford, ON. L3Z 4L5

Job	Truss	Truss Type	Qty	Ply	Buildings A-H	U1530845
N0653A	K2	GABLE	13	1		

Alliance Truss (CA), Abbotsford, BC - V2S 7P6,

8.820 s Aug 30 2024 MiTek Industries, Inc. Thu Sep 12 02:48:08 2024 Page 1

ID:hFyjDMxrTsEK_kgkR0vWWWzFlgc-45GjKV5VXY4CH1?zj0h4W5tDfnlKvrk_KvPmyeVr5

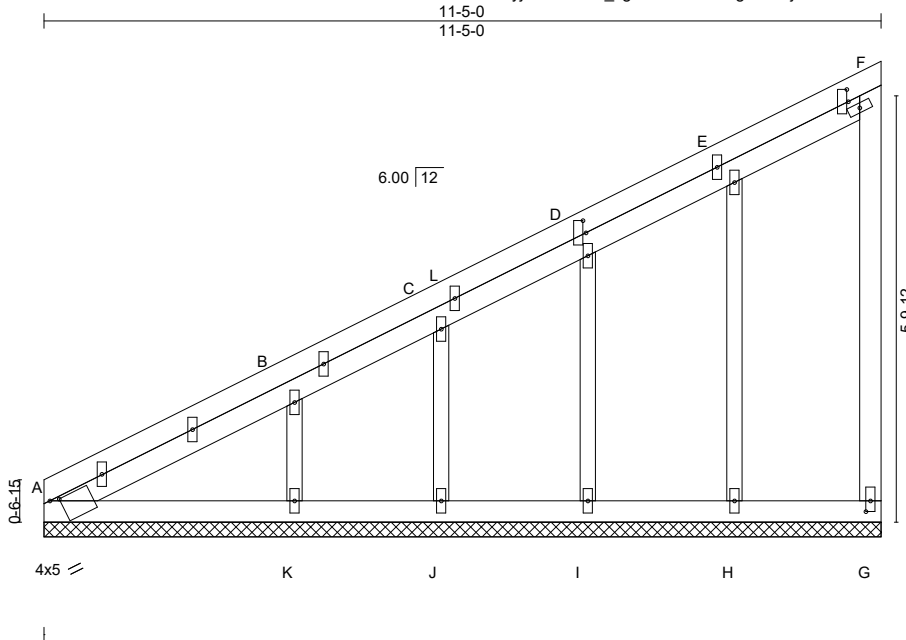

Scale = 1:31.4

Plate Offsets (X,Y)-- [A:0-1-8,0-0-7], [D:0-2-0,0-0-8], [F:0-2-0,0-0-4], [G:0-1-12,0-0-12]

LOADING (psf)	SPACING-	CSI.	DEFL.	PLATES	GRIP
TCLL 25.0 (Roof Snow=25.0)	2-0-0 Plate Grip DOL 1.15 Lumber DOL 1.15	TC 0.58 BC 0.55 WB 0.13 Matrix-S	in (loc) l/defl L/d Vert(LL) n/a - n/a 999 Vert(CT) n/a - n/a 999 Horz(CT) -0.03 G n/a n/a	MT20	197/144
TCDL 12.0	Rep Stress Incr YES				
BCLL 0.0 *	Code IBC2018/TPI2014				
BCDL 10.0				Weight: 58 lb	FT = 20%

LUMBER-

TOP CHORD 2x4 SPF No.2
 BOT CHORD 2x4 SPF No.2
 WEBS 2x4 SPF No.2
 OTHERS 2x3 SPF No.2

BRACING-

TOP CHORD Structural wood sheathing directly applied or 3-3-9 oc purlins, except end verticals.
 BOT CHORD Rigid ceiling directly applied or 3-6-11 oc bracing.

REACTIONS.

All bearings 11-5-0.
 (lb) - Max Horz A=172(LC 34)
 Max Uplift All uplift 100 lb or less at joint(s) G, H, I, J, K except A=1292(LC 31)
 Max Grav All reactions 250 lb or less at joint(s) G, J except A=1405(LC 38), H=275(LC 16), I=276(LC 16), K=318(LC 1)

FORCES. (lb) - Max. Comp./Max. Ten. - All forces 250 (lb) or less except when shown.

TOP CHORD A-B=-3139/2996, B-C=-2237/2131, C-D=-1686/1604, D-E=-1140/1078, E-F=-587/549
 BOT CHORD A-K=-2740/2746, J-K=-1938/1925, I-J=-1459/1445, H-I=-979/965, G-H=-499/485

NOTES-

- 1) Wind: ASCE 7-16; Vult=115mph (3-second gust) Vasd=91mph; TCDL=4.2psf; BCDL=5.0psf; h=30ft; Ke=1.00; Cat. II; Exp B; Enclosed; MWFRS (envelope) gable end zone; cantilever left and right exposed; end vertical left and right exposed; Lumber DOL=1.33 plate grip DOL=1.33
- 2) Truss designed for wind loads in the plane of the truss only. For studs exposed to wind (normal to the face), see Standard Industry Gable End Details as applicable, or consult qualified building designer as per ANSI/TPI 1.
- 3) TCLL: ASCE 7-16; Pf=25.0 psf (Lum DOL = 1.15 Plate DOL = 1.15); Is=1.0; Rough Cat B; Partially Exp.; Ce=1.0; Cs=1.00; Ct=1.10
- 4) Unbalanced snow loads have been considered for this design.
- 5) All plates are 1.5x4 MT20 unless otherwise indicated.
- 6) Gable requires continuous bottom chord bearing.
- 7) Gable studs spaced at 2-0-0 oc.
- 8) This truss has been designed for a 10.0 psf bottom chord live load nonconcurrent with any other live loads.
- 9) * This truss has been designed for a live load of 20.0psf on the bottom chord in all areas where a rectangle 3-6-0 tall by 2-0-0 wide will fit between the bottom chord and any other members.
- 10) Provide mechanical connection (by others) of truss to bearing plate capable of withstanding 100 lb uplift at joint(s) G, H, I, J, K except (jt=lb) A=1292.
- 11) This truss is designed in accordance with the 2018 International Building Code section 2306.1 and referenced standard ANSI/TPI 1.
- 12) This truss has been designed for a total drag load of 240 plf. Lumber DOL=(1.33) Plate grip DOL=(1.33) Connect truss to resist drag loads along bottom chord from 0-0-0 to 11-5-0 for 240.0 plf.
- 13) No notches allowed in overhang and 0 from left end and 0 from right end or 12" along rake from scarf, whichever is larger. Minimum 1.5x4 tie plates required at 2-0-0 o.c. maximum between the stacking chords. For edge-wise notching, provide at least one tie plate between each notch.



September 12, 2024

WARNING - Verify design parameters and READ NOTES ON THIS AND INCLUDED MITEK REFERENCE PAGE MII-7473 rev. 6/30/2020 BEFORE USE.

Design valid for use only with MiTek® connectors. This design is based only upon parameters shown, and is for an individual building component, not a truss system. Before use, the building designer must verify the applicability of design parameters and properly incorporate this design into the overall building design. Bracing indicated is to prevent buckling of individual truss web and/or chord members only. Additional temporary and permanent bracing is always required for stability and to prevent collapse with possible personal injury and property damage. For general guidance regarding the fabrication, storage, delivery, erection and bracing of trusses and truss systems, see

ANSI/TPI1 Quality Criteria, DSB-89 and BCSI Building Component Safety Information available from Truss Plate Institute, 2670 Crain Highway, Suite 203 Waldorf, MD 20601



240 Stirling Crescent
 Bradford, ON. L3Z 4L5

Job N0653A	Truss L1	Truss Type Monopitch Supported Gable	Qty 7	Ply 1	Buildings A-H Job Reference (optional)	U1530782
---------------	-------------	---	----------	----------	---	----------

Alliance Truss (CA), Abbotsford, BC - V2S 7P6,

8.630 s Jul 12 2024 MiTek Industries, Inc. Thu Sep 12 02:47:31 2024 Page 1

ID:hFyjDMxrTsEK_kgkR0vWWVzFfgc-RfC?PsB70Hq3NSgPqnL8w3ulTXbGKWrCDoi7J4zJC?f

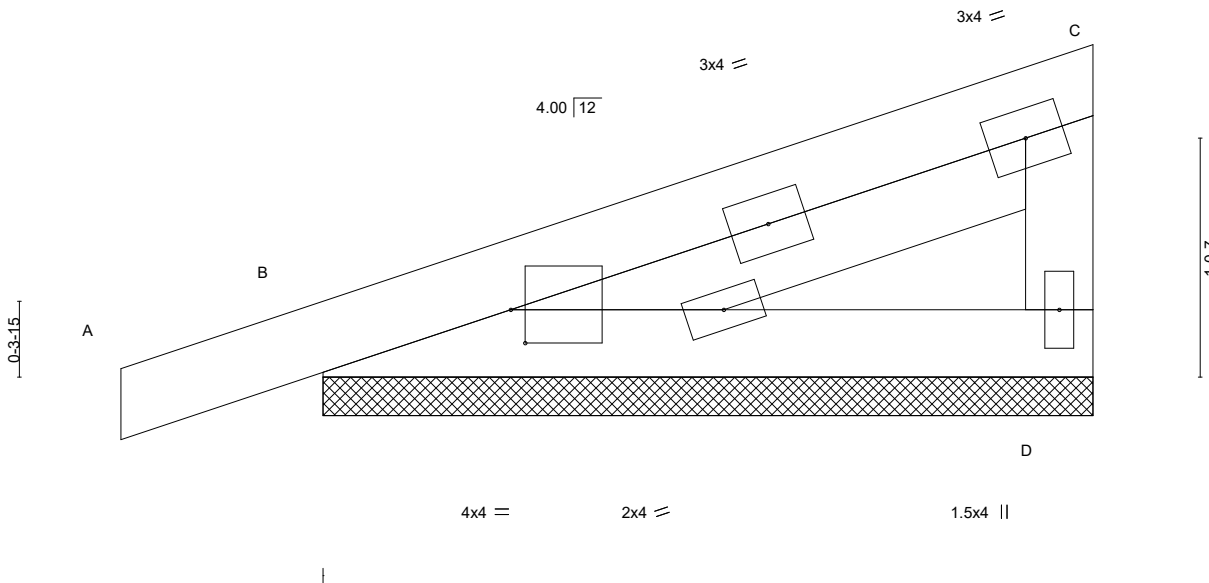

Plate Offsets (X,Y)-- [B:0-0-12,0-1-12]

LOADING (psf)	SPACING-	CSI.	DEFL.	in (loc)	l/defl	L/d	PLATES	GRIP
TCLL 25.0 (Roof Snow=25.0)	2-0-0 Plate Grip DOL 1.15	TC 0.09	Vert(LL)	-0.00	A	n/r	MT20	197/144
TCDL 12.0	Lumber DOL 1.15	BC 0.10	Vert(CT)	0.00	A	n/r		
BCLL 0.0 *	Rep Stress Incr YES	WB 0.00	Horz(CT)	-0.00	D	n/a		
BCDL 10.0	Code IBC2018/TPI2014	Matrix-P					Weight: 13 lb	FT = 20%

LUMBER-

TOP CHORD 2x4 SPF No.2
 BOT CHORD 2x4 SPF No.2
 WEBS 2x4 SPF No.2

BRACING-

TOP CHORD Structural wood sheathing directly applied or 3-4-0 oc purlins, except end verticals.
 BOT CHORD Rigid ceiling directly applied or 10-0-0 oc bracing.

REACTIONS.

(size) D=3-4-0, B=3-4-0
 Max Horz B=40(LC 7)
 Max Uplift D=-19(LC 10), B=-48(LC 6)
 Max Grav D=183(LC 17), B=297(LC 17)

FORCES. (lb) - Max. Comp./Max. Ten. - All forces 250 (lb) or less except when shown.

NOTES-

- 1) Wind: ASCE 7-16; Vult=115mph (3-second gust) Vasd=91mph; TCDL=4.2psf; BCDL=5.0psf; h=30ft; Ke=1.00; Cat. II; Exp B; Enclosed; MWFRS (envelope) gable end zone; cantilever left and right exposed ; end vertical left and right exposed; Lumber DOL=1.33 plate grip DOL=1.33
- 2) Truss designed for wind loads in the plane of the truss only. For studs exposed to wind (normal to the face), see Standard Industry Gable End Details as applicable, or consult qualified building designer as per ANSI/TPI 1.
- 3) TCLL: ASCE 7-16; Pf=25.0 psf (Lum DOL=1.15 Plate DOL=1.15); Is=1.0; Rough Cat B; Partially Exp.; Ce=1.0; Cs=1.00; Ct=1.10
- 4) Unbalanced snow loads have been considered for this design.
- 5) This truss has been designed for greater of min roof live load of 20.0 psf or 2.00 times flat roof load of 25.0 psf on overhangs non-concurrent with other live loads.
- 6) Gable requires continuous bottom chord bearing.
- 7) Gable studs spaced at 2-0-0 oc.
- 8) This truss has been designed for a 10.0 psf bottom chord live load nonconcurrent with any other live loads.
- 9) * This truss has been designed for a live load of 20.0psf on the bottom chord in all areas where a rectangle 3-6-0 tall by 2-0-0 wide will fit between the bottom chord and any other members.
- 10) Provide mechanical connection (by others) of truss to bearing plate capable of withstanding 100 lb uplift at joint(s) D, B.
- 11) Beveled plate or shim required to provide full bearing surface with truss chord at joint(s) B.
- 12) This truss is designed in accordance with the 2018 International Building Code section 2306.1 and referenced standard ANSI/TPI 1.



September 12, 2024

WARNING - Verify design parameters and READ NOTES ON THIS AND INCLUDED MITEK REFERENCE PAGE MII-7473 rev. 6/30/2020 BEFORE USE.

Design valid for use only with MiTek® connectors. This design is based only upon parameters shown, and is for an individual building component, not a truss system. Before use, the building designer must verify the applicability of design parameters and properly incorporate this design into the overall building design. Bracing indicated is to prevent buckling of individual truss web and/or chord members only. Additional temporary and permanent bracing is always required for stability and to prevent collapse with possible personal injury and property damage. For general guidance regarding the fabrication, storage, delivery, erection and bracing of trusses and truss systems, see **ANSI/TPI1 Quality Criteria, DSB-89 and BCSI Building Component Safety Information** available from Truss Plate Institute, 2670 Crain Highway, Suite 203 Waldorf, MD 20601



240 Stirling Crescent
 Bradford, ON. L3Z 4L5

Job	Truss	Truss Type	Qty	Ply	Buildings A-H	U1530783
N0653A	L2	Monopitch	42	1		

Alliance Truss (CA), Abbotsford, BC - V2S 7P6,

8.630 s Jul 12 2024 MiTek Industries, Inc. Thu Sep 12 02:47:32 2024 Page 1

ID:hFyjDMxrTsEK_kgkR0vWWVzF1gc-RfC?PsB70Hq3NSgPqnL8w3ulTXbGKWrCDoi7J4zJC?f
3-4-0
3-4-0

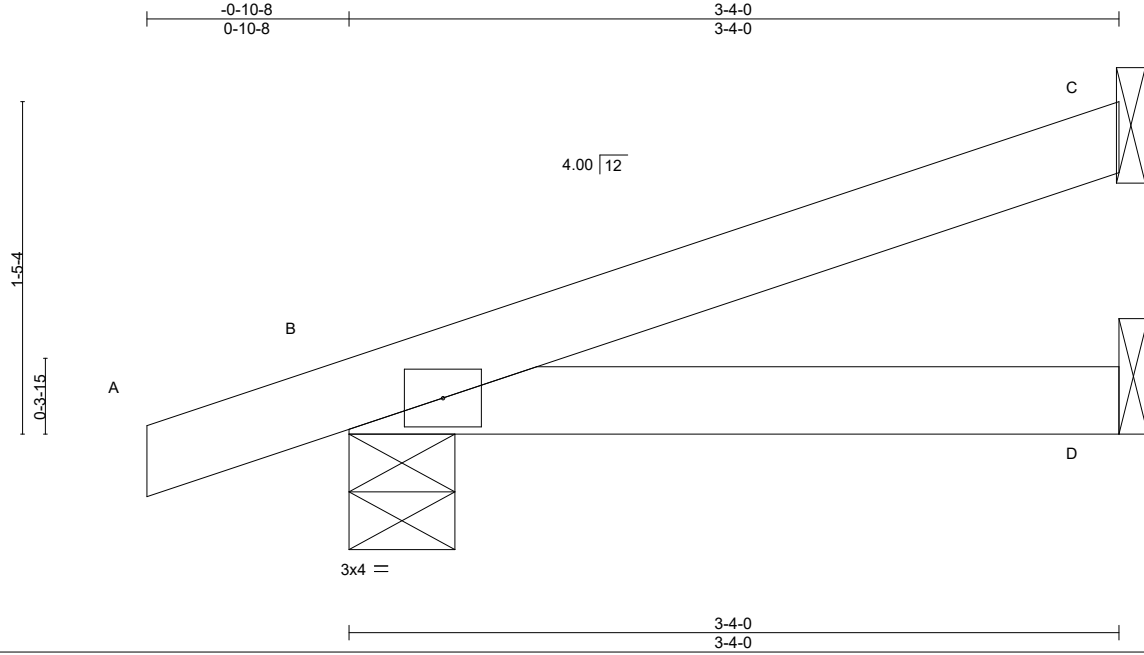

Scale = 1:10.0

LOADING (psf)	SPACING-	CSI.	DEFL.	PLATES	GRIP
TCLL 25.0	2-0-0	TC 0.17	in (loc) l/defl L/d	MT20	197/144
(Roof Snow=25.0)	Plate Grip DOL 1.15	BC 0.16	Vert(LL) -0.01 D-G >999 360		
TCDL 12.0	Lumber DOL 1.15	WB 0.00	Vert(CT) -0.02 D-G >999 240		
BCLL 0.0 *	Rep Stress Incr YES	Matrix-MP	Horz(CT) 0.00 B n/a n/a		
BCDL 10.0	Code IBC2018/TPI2014		Wind(LL) 0.00 D-G >999 240	Weight: 9 lb	FT = 20%

LUMBER-	BRACING-
TOP CHORD 2x4 SPF No.2	TOP CHORD Structural wood sheathing directly applied or 3-4-0 oc purlins.
BOT CHORD 2x4 SPF No.2	BOT CHORD Rigid ceiling directly applied or 10-0-0 oc bracing.

REACTIONS. (size) C=Mechanical, B=0-5-8, D=Mechanical
 Max Horz B=45(LC 6)
 Max Uplift C=-28(LC 10), B=-46(LC 6)
 Max Grav C=132(LC 17), B=302(LC 17), D=59(LC 5)

FORCES. (lb) - Max. Comp./Max. Ten. - All forces 250 (lb) or less except when shown.

- NOTES-**
- 1) Wind: ASCE 7-16; Vult=115mph (3-second gust) Vasd=91mph; TCDL=4.2psf; BCDL=5.0psf; h=30ft; Ke=1.00; Cat. II; Exp B; Enclosed; MWFRS (envelope) gable end zone; cantilever left and right exposed ; end vertical left and right exposed; Lumber DOL=1.33 plate grip DOL=1.33
 - 2) TCLL: ASCE 7-16; Pf=25.0 psf (Lum DOL=1.15 Plate DOL=1.15); Is=1.0; Rough Cat B; Partially Exp.; Ce=1.0; Cs=1.0; Ct=1.10
 - 3) Unbalanced snow loads have been considered for this design.
 - 4) This truss has been designed for greater of min roof live load of 20.0 psf or 2.00 times flat roof load of 25.0 psf on overhangs non-concurrent with other live loads.
 - 5) This truss has been designed for a 10.0 psf bottom chord live load nonconcurrent with any other live loads.
 - 6) * This truss has been designed for a live load of 20.0psf on the bottom chord in all areas where a rectangle 3-6-0 tall by 2-0-0 wide will fit between the bottom chord and any other members.
 - 7) Refer to girder(s) for truss to truss connections.
 - 8) Provide mechanical connection (by others) of truss to bearing plate capable of withstanding 100 lb uplift at joint(s) C, B.
 - 9) This truss is designed in accordance with the 2018 International Building Code section 2306.1 and referenced standard ANSI/TPI 1.



September 12, 2024

WARNING - Verify design parameters and READ NOTES ON THIS AND INCLUDED MITEK REFERENCE PAGE MII-7473 rev. 6/30/2020 BEFORE USE.
 Design valid for use only with MiTek® connectors. This design is based only upon parameters shown, and is for an individual building component, not a truss system. Before use, the building designer must verify the applicability of design parameters and properly incorporate this design into the overall building design. Bracing indicated is to prevent buckling of individual truss web and/or chord members only. Additional temporary and permanent bracing is always required for stability and to prevent collapse with possible personal injury and property damage. For general guidance regarding the fabrication, storage, delivery, erection and bracing of trusses and truss systems, see **ANSI/TPI1 Quality Criteria, DSB-89 and BCSI Building Component Safety Information** available from Truss Plate Institute, 2670 Crain Highway, Suite 203 Waldorf, MD 20601



240 Stirling Crescent
Bradford, ON. L3Z 4L5

Job N0653A	Truss L3	Truss Type Monopitch Supported Gable	Qty 9	Ply 1	Buildings A-H Job Reference (optional)	U1530784
---------------	-------------	---	----------	----------	---	----------

Alliance Truss (CA), Abbotsford, BC - V2S 7P6,

8.630 s Jul 12 2024 MiTek Industries, Inc. Thu Sep 12 02:47:32 2024 Page 1

ID:hFyjDMxrTsEK_kgkR0vWWVzFfgc-RfC?PsB70Hq3NSgPqnL8w3ulTXbGKwRCDoi7J4zJC?f

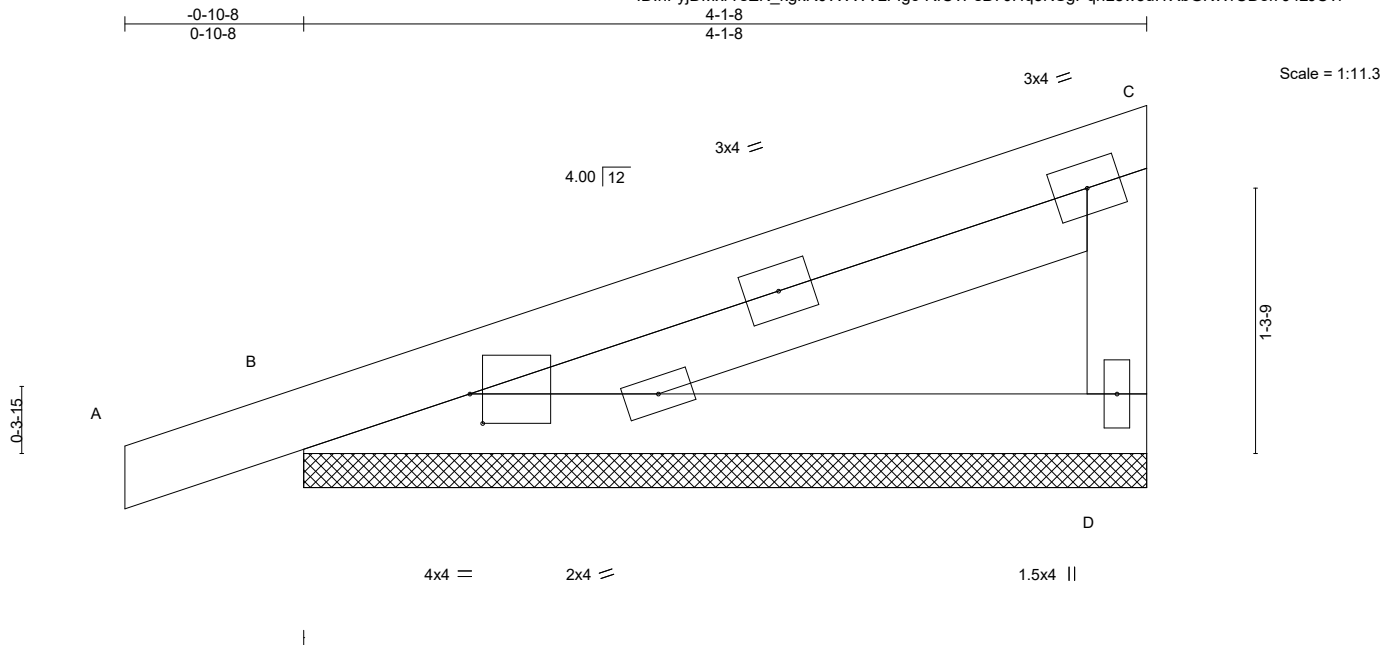

Plate Offsets (X,Y)-- [B:0-0-12,0-1-12]

LOADING (psf)	SPACING-	CSI.	DEFL.	in (loc)	l/defl	L/d	PLATES	GRIP
TCLL 25.0 (Roof Snow=25.0)	2-0-0 Plate Grip DOL 1.15	TC 0.13	Vert(LL)	-0.00	A	n/r	MT20	197/144
TCDL 12.0	Lumber DOL 1.15	BC 0.16	Vert(CT)	0.00	A	n/r		
BCLL 0.0 *	Rep Stress Incr YES	WB 0.00	Horz(CT)	-0.00	D	n/a		
BCDL 10.0	Code IBC2018/TPI2014	Matrix-P					Weight: 16 lb	FT = 20%

LUMBER-

TOP CHORD 2x4 SPF No.2
 BOT CHORD 2x4 SPF No.2
 WEBS 2x4 SPF No.2

BRACING-

TOP CHORD Structural wood sheathing directly applied or 4-1-8 oc purlins, except end verticals.
 BOT CHORD Rigid ceiling directly applied or 10-0-0 oc bracing.

REACTIONS.

(size) D=4-1-8, B=4-1-8
 Max Horz B=49(LC 7)
 Max Uplift D=-25(LC 10), B=-52(LC 6)
 Max Grav D=238(LC 17), B=350(LC 17)

FORCES. (lb) - Max. Comp./Max. Ten. - All forces 250 (lb) or less except when shown.

NOTES-

- Wind: ASCE 7-16; Vult=115mph (3-second gust) Vasd=91mph; TCDL=4.2psf; BCDL=5.0psf; h=30ft; Ke=1.00; Cat. II; Exp B; Enclosed; MWFRS (envelope) gable end zone; cantilever left and right exposed; end vertical left and right exposed; Lumber DOL=1.33 plate grip DOL=1.33
- Truss designed for wind loads in the plane of the truss only. For studs exposed to wind (normal to the face), see Standard Industry Gable End Details as applicable, or consult qualified building designer as per ANSI/TPI 1.
- TCLL: ASCE 7-16; Pf=25.0 psf (Lum DOL=1.15 Plate DOL=1.15); Is=1.0; Rough Cat B; Partially Exp.; Ce=1.0; Cs=1.00; Ct=1.10
- Unbalanced snow loads have been considered for this design.
- This truss has been designed for greater of min roof live load of 20.0 psf or 2.00 times flat roof load of 25.0 psf on overhangs non-concurrent with other live loads.
- Gable requires continuous bottom chord bearing.
- Gable studs spaced at 2-0-0 oc.
- This truss has been designed for a 10.0 psf bottom chord live load nonconcurrent with any other live loads.
- * This truss has been designed for a live load of 20.0psf on the bottom chord in all areas where a rectangle 3-6-0 tall by 2-0-0 wide will fit between the bottom chord and any other members.
- Provide mechanical connection (by others) of truss to bearing plate capable of withstanding 100 lb uplift at joint(s) D, B.
- This truss is designed in accordance with the 2018 International Building Code section 2306.1 and referenced standard ANSI/TPI 1.



September 12, 2024

WARNING - Verify design parameters and READ NOTES ON THIS AND INCLUDED MITEK REFERENCE PAGE MII-7473 rev. 6/30/2020 BEFORE USE.

Design valid for use only with MiTek® connectors. This design is based only upon parameters shown, and is for an individual building component, not a truss system. Before use, the building designer must verify the applicability of design parameters and properly incorporate this design into the overall building design. Bracing indicated is to prevent buckling of individual truss web and/or chord members only. Additional temporary and permanent bracing is always required for stability and to prevent collapse with possible personal injury and property damage. For general guidance regarding the fabrication, storage, delivery, erection and bracing of trusses and truss systems, see **ANSI/TPI1 Quality Criteria, DSB-89 and BCSI Building Component Safety Information** available from Truss Plate Institute, 2670 Crain Highway, Suite 203 Waldorf, MD 20601



240 Stirling Crescent
 Bradford, ON. L3Z 4L5

Job	Truss	Truss Type	Qty	Ply	Buildings A-H	U1530785
N0653A	L4	JACK	54	1		

Alliance Truss (CA), Abbotsford, BC - V2S 7P6,

8.630 s Jul 12 2024 MiTek Industries, Inc. Thu Sep 12 02:47:33 2024 Page 1

ID:hFyjDMxrTsEK_kgkR0vWWVzFjgc-RfC?PsB70Hq3NSgPqnL8w3ulTXbGKWrCDoi7J4zJC?f

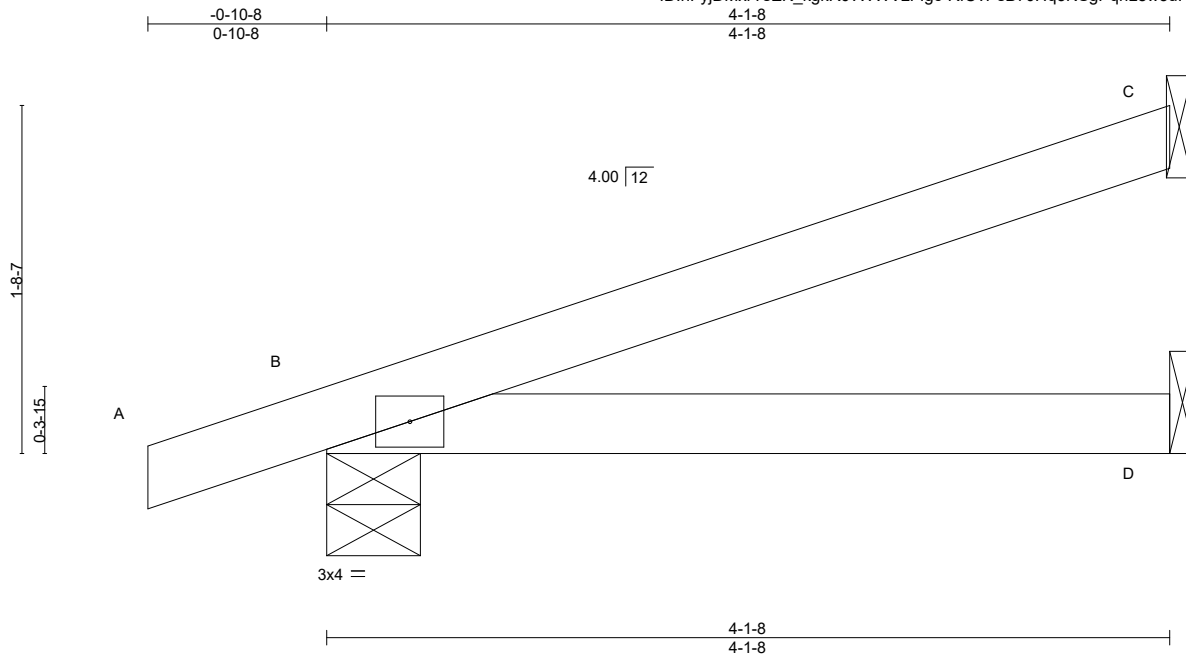

LOADING (psf)	SPACING-	CSI.	DEFL.	PLATES	GRIP
TCLL 25.0	2-0-0	TC 0.29	in (loc) l/defl L/d	MT20	197/144
(Roof Snow=25.0)	Plate Grip DOL 1.15	BC 0.26	Vert(LL) -0.02 D-G >999 360		
TCDL 12.0	Lumber DOL 1.15	WB 0.00	Vert(CT) -0.04 D-G >999 240		
BCLL 0.0 *	Rep Stress Incr YES	Matrix-MP	Horz(CT) 0.00 B n/a n/a		
BCDL 10.0	Code IBC2018/TPI2014		Wind(LL) 0.01 D-G >999 240	Weight: 11 lb	FT = 20%

LUMBER-

TOP CHORD 2x4 SPF No.2
 BOT CHORD 2x4 SPF No.2

BRACING-

TOP CHORD Structural wood sheathing directly applied or 4-1-8 oc purlins.
 BOT CHORD Rigid ceiling directly applied or 10-0-0 oc bracing.

REACTIONS.

(size) C=Mechanical, B=0-5-8, D=Mechanical
 Max Horz B=53(LC 6)
 Max Uplift C=-36(LC 10), B=-48(LC 6)
 Max Grav C=174(LC 17), B=356(LC 17), D=74(LC 5)

FORCES. (lb) - Max. Comp./Max. Ten. - All forces 250 (lb) or less except when shown.

NOTES-

- 1) Wind: ASCE 7-16; Vult=115mph (3-second gust) Vasd=91mph; TCDL=4.2psf; BCDL=5.0psf; h=30ft; Ke=1.00; Cat. II; Exp B; Enclosed; MWFRS (envelope) gable end zone; cantilever left and right exposed; end vertical left and right exposed; Lumber DOL=1.33 plate grip DOL=1.33
- 2) TCLL: ASCE 7-16; Pf=25.0 psf (Lum DOL=1.15 Plate DOL=1.15); Is=1.0; Rough Cat B; Partially Exp.; Ce=1.0; Cs=1.0; Ct=1.10
- 3) Unbalanced snow loads have been considered for this design.
- 4) This truss has been designed for greater of min roof live load of 20.0 psf or 2.00 times flat roof load of 25.0 psf on overhangs non-concurrent with other live loads.
- 5) This truss has been designed for a 10.0 psf bottom chord live load nonconcurrent with any other live loads.
- 6) * This truss has been designed for a live load of 20.0psf on the bottom chord in all areas where a rectangle 3-6-0 tall by 2-0-0 wide will fit between the bottom chord and any other members.
- 7) Refer to girder(s) for truss to truss connections.
- 8) Provide mechanical connection (by others) of truss to bearing plate capable of withstanding 100 lb uplift at joint(s) C, B.
- 9) This truss is designed in accordance with the 2018 International Building Code section 2306.1 and referenced standard ANSI/TPI 1.



September 12, 2024

WARNING - Verify design parameters and READ NOTES ON THIS AND INCLUDED MITEK REFERENCE PAGE MII-7473 rev. 6/30/2020 BEFORE USE.

Design valid for use only with MiTek® connectors. This design is based only upon parameters shown, and is for an individual building component, not a truss system. Before use, the building designer must verify the applicability of design parameters and properly incorporate this design into the overall building design. Bracing indicated is to prevent buckling of individual truss web and/or chord members only. Additional temporary and permanent bracing is always required for stability and to prevent collapse with possible personal injury and property damage. For general guidance regarding the fabrication, storage, delivery, erection and bracing of trusses and truss systems, see

ANSI/TPI1 Quality Criteria, DSB-89 and BCSI Building Component

Safety Information available from Truss Plate Institute, 2670 Crain Highway, Suite 203 Waldorf, MD 20601



240 Stirling Crescent
 Bradford, ON. L3Z 4L5

Job N0653A	Truss L5	Truss Type Monopitch Supported Gable	Qty 2	Ply 1	Buildings A-H Job Reference (optional)	U1530786
---------------	-------------	---	----------	----------	---	----------

Alliance Truss (CA), Abbotsford, BC - V2S 7P6,

8.630 s Jul 12 2024 MiTek Industries, Inc. Thu Sep 12 02:47:33 2024 Page 1

ID:hFyjDMxrTsEK_kgkR0vWWVzF1gc-RfC?PsB70Hq3NSgPqnL8w3ulTXbGKWrCDoi7J4zJC?f



Scale = 1:7.8

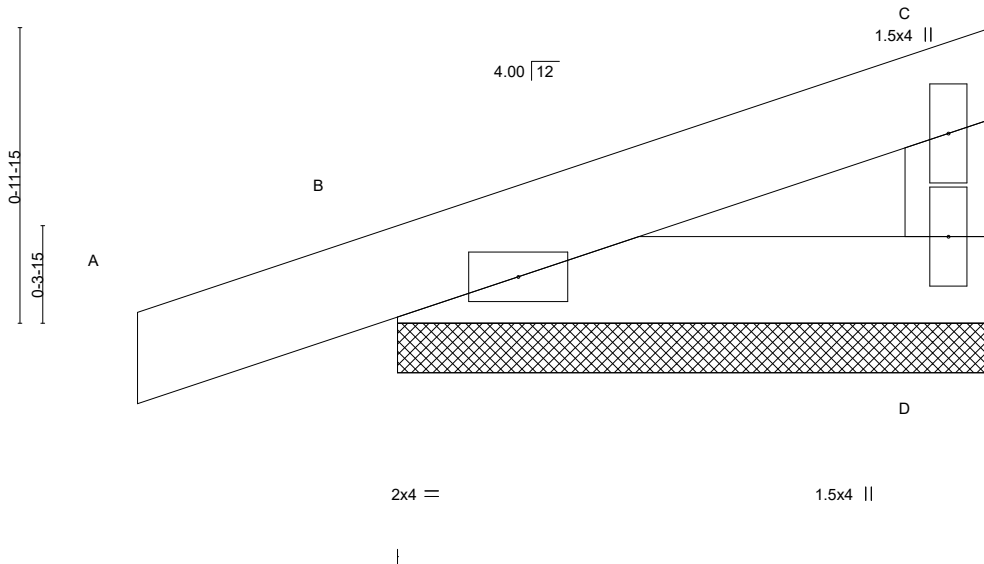

LOADING (psf)	SPACING-	2-0-0	CSI.	DEFL.	in (loc)	l/defl	L/d	PLATES	GRIP
TCLL 25.0	Plate Grip DOL	1.15	TC 0.09	Vert(LL)	0.00	A	n/r	MT20	197/144
(Roof Snow=25.0)	Lumber DOL	1.15	BC 0.03	Vert(CT)	0.00	A	n/r		
TCDL 12.0	Rep Stress Incr	YES	WB 0.00	Horz(CT)	-0.00	D	n/a		
BCLL 0.0 *	Code IBC2018/TPI2014		Matrix-P					Weight: 6 lb	FT = 20%
BCDL 10.0									

LUMBER-

TOP CHORD 2x4 SPF No.2
 BOT CHORD 2x4 SPF No.2
 WEBS 2x4 SPF No.2

BRACING-

TOP CHORD Structural wood sheathing directly applied or 2-0-0 oc purlins, except end verticals.
 BOT CHORD Rigid ceiling directly applied or 10-0-0 oc bracing.

REACTIONS.

(size) D=2-0-0, B=2-0-0
 Max Horz B=26(LC 7)
 Max Uplift D=-9(LC 10), B=-45(LC 6)
 Max Grav D=89(LC 17), B=214(LC 17)

FORCES. (lb) - Max. Comp./Max. Ten. - All forces 250 (lb) or less except when shown.

NOTES-

- 1) Wind: ASCE 7-16; Vult=115mph (3-second gust) Vasd=91mph; TCDL=4.2psf; BCDL=5.0psf; h=30ft; Ke=1.00; Cat. II; Exp B; Enclosed; MWFRS (envelope) gable end zone; cantilever left and right exposed; end vertical left and right exposed; Lumber DOL=1.33 plate grip DOL=1.33
- 2) Truss designed for wind loads in the plane of the truss only. For studs exposed to wind (normal to the face), see Standard Industry Gable End Details as applicable, or consult qualified building designer as per ANSI/TPI 1.
- 3) TCLL: ASCE 7-16; Pf=25.0 psf (Lum DOL=1.15 Plate DOL=1.15); Is=1.0; Rough Cat B; Partially Exp.; Ce=1.0; Cs=1.0; Ct=1.10
- 4) Unbalanced snow loads have been considered for this design.
- 5) This truss has been designed for greater of min roof live load of 20.0 psf or 2.00 times flat roof load of 25.0 psf on overhangs non-concurrent with other live loads.
- 6) Gable requires continuous bottom chord bearing.
- 7) Gable studs spaced at 2-0-0 oc.
- 8) This truss has been designed for a 10.0 psf bottom chord live load nonconcurrent with any other live loads.
- 9) * This truss has been designed for a live load of 20.0psf on the bottom chord in all areas where a rectangle 3-6-0 tall by 2-0-0 wide will fit between the bottom chord and any other members.
- 10) Provide mechanical connection (by others) of truss to bearing plate capable of withstanding 100 lb uplift at joint(s) D, B.
- 11) This truss is designed in accordance with the 2018 International Building Code section 2306.1 and referenced standard ANSI/TPI 1.



September 12, 2024

WARNING - Verify design parameters and READ NOTES ON THIS AND INCLUDED MITEK REFERENCE PAGE MII-7473 rev. 6/30/2020 BEFORE USE.

Design valid for use only with MiTek® connectors. This design is based only upon parameters shown, and is for an individual building component, not a truss system. Before use, the building designer must verify the applicability of design parameters and properly incorporate this design into the overall building design. Bracing indicated is to prevent buckling of individual truss web and/or chord members only. Additional temporary and permanent bracing is always required for stability and to prevent collapse with possible personal injury and property damage. For general guidance regarding the fabrication, storage, delivery, erection and bracing of trusses and truss systems, see

ANSI/TPI1 Quality Criteria, DSB-89 and BCSI Building Component

Safety Information available from Truss Plate Institute, 2670 Crain Highway, Suite 203 Waldorf, MD 20601



240 Stirling Crescent
 Bradford, ON. L3Z 4L5

Job	Truss	Truss Type	Qty	Ply	Buildings A-H	U1530787
N0653A	L6	Monopitch	9	1		

Alliance Truss (CA), Abbotsford, BC - V2S 7P6,

8.630 s Jul 12 2024 MiTek Industries, Inc. Thu Sep 12 02:47:34 2024 Page 1

ID:hFyjDMxrTsEK_kgkR0vWWVzFfgc-RfC?PsB70Hq3NSgPqnL8w3ulTXbGKWrCDoi7J4zJC?f

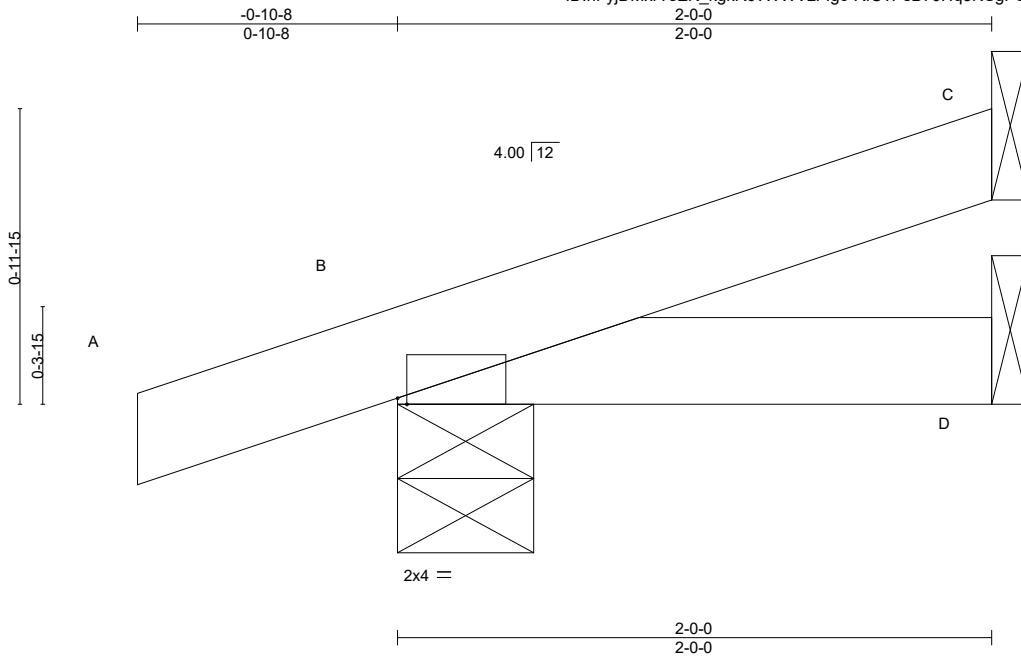

Plate Offsets (X,Y)-- [B:0-0-6,Edge]

LOADING (psf)	SPACING-	CSI.	DEFL.	in (loc)	l/defl	L/d	PLATES	GRIP
TCLL 25.0 (Roof Snow=25.0)	2-0-0 Plate Grip DOL 1.15	TC 0.15	Vert(LL)	-0.00	G	>999	MT20	197/144
TCDL 12.0	Lumber DOL 1.15	BC 0.20	Vert(CT)	-0.01	G	>999		
BCLL 0.0 *	Rep Stress Incr YES	WB 0.00	Horz(CT)	0.00	B	n/a		
BCDL 10.0	Code IBC2018/TPI2014	Matrix-MP	Wind(LL)	0.00	G	>999	Weight: 6 lb	FT = 20%

LUMBER-

TOP CHORD 2x4 SPF No.2
BOT CHORD 2x4 SPF No.2

BRACING-

TOP CHORD Structural wood sheathing directly applied or 2-0-0 oc purlins.
BOT CHORD Rigid ceiling directly applied or 10-0-0 oc bracing.

REACTIONS.

(size) B=0-5-8, D=Mechanical
Max Horz B=30(LC 6)
Max Uplift B=-42(LC 6), D=-12(LC 7)
Max Grav B=222(LC 17), D=104(LC 16)

FORCES. (lb) - Max. Comp./Max. Ten. - All forces 250 (lb) or less except when shown.

NOTES-

- 1) Wind: ASCE 7-16; Vult=115mph (3-second gust) Vasd=91mph; TCDL=4.2psf; BCDL=5.0psf; h=30ft; Ke=1.00; Cat. II; Exp B; Enclosed; MWFRS (envelope) gable end zone; cantilever left and right exposed; end vertical left and right exposed; Lumber DOL=1.33 plate grip DOL=1.33
- 2) TCLL: ASCE 7-16; Pf=25.0 psf (Lum DOL=1.15 Plate DOL=1.15); Is=1.0; Rough Cat B; Partially Exp.; Ce=1.0; Cs=1.00; Ct=1.10
- 3) Unbalanced snow loads have been considered for this design.
- 4) This truss has been designed for greater of min roof live load of 20.0 psf or 2.00 times flat roof load of 25.0 psf on overhangs non-concurrent with other live loads.
- 5) This truss has been designed for a 10.0 psf bottom chord live load nonconcurrent with any other live loads.
- 6) * This truss has been designed for a live load of 20.0psf on the bottom chord in all areas where a rectangle 3-6-0 tall by 2-0-0 wide will fit between the bottom chord and any other members.
- 7) Refer to girder(s) for truss to truss connections.
- 8) Provide mechanical connection (by others) of truss to bearing plate capable of withstanding 100 lb uplift at joint(s) B, D.
- 9) This truss is designed in accordance with the 2018 International Building Code section 2306.1 and referenced standard ANSI/TPI 1.



September 12, 2024

WARNING - Verify design parameters and READ NOTES ON THIS AND INCLUDED MITEK REFERENCE PAGE MII-7473 rev. 6/30/2020 BEFORE USE.

Design valid for use only with MiTek® connectors. This design is based only upon parameters shown, and is for an individual building component, not a truss system. Before use, the building designer must verify the applicability of design parameters and properly incorporate this design into the overall building design. Bracing indicated is to prevent buckling of individual truss web and/or chord members only. Additional temporary and permanent bracing is always required for stability and to prevent collapse with possible personal injury and property damage. For general guidance regarding the fabrication, storage, delivery, erection and bracing of trusses and truss systems, see

Safety Information available from Truss Plate Institute, 2670 Crain Highway, Suite 203 Waldorf, MD 20601



240 Stirling Crescent
Bradford, ON. L3Z 4L5

Job	Truss	Truss Type	Qty	Ply	Buildings A-H	U1530846
N0653A	M1	Monopitch	44	1		

Alliance Truss (CA), Abbotsford, BC - V2S 7P6, 8.820 s Aug 30 2024 MiTek Industries, Inc. Thu Sep 12 02:48:09 2024 Page 1

ID:hFyjDMxrTsEK_kgkR0vWwVzFlgc-YHq5Xr57HrC3vBa9G0Xwcje5G36R4jK_ze3TxDyeVr4

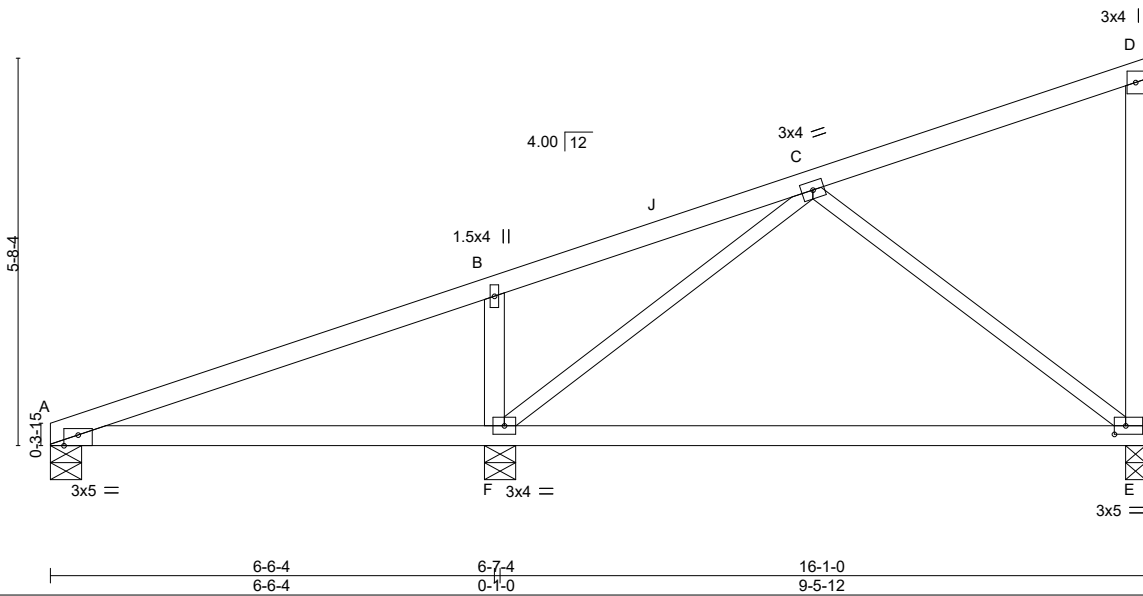

Scale = 1:33.8

Plate Offsets (X,Y)-- [A:0-2-8,Edge], [E:0-2-0,0-1-8]

LOADING (psf)	SPACING-	CSI.	DEFL.	in (loc)	l/defl	L/d	PLATES	GRIP
TCLL 25.0 (Roof Snow=25.0)	2-0-0 Plate Grip DOL 1.15	TC 0.43	Vert(LL)	-0.21	E-F	>545	MT20	197/144
TCDL 12.0	Lumber DOL 1.15	BC 0.62	Vert(CT)	-0.40	E-F	>283		
BCLL 0.0 *	Rep Stress Incr YES	WB 0.37	Horz(CT)	0.01	E	n/a		
BCDL 10.0	Code IBC2018/TPI2014	Matrix-MS	Wind(LL)	0.04	F-I	>999		
							Weight: 55 lb	FT = 20%

LUMBER-

TOP CHORD 2x4 SPF No.2
 BOT CHORD 2x4 SPF No.2
 WEBS 2x4 SPF No.2 *Except*
 C-F,C-E: 2x3 SPF No.2

BRACING-

TOP CHORD Structural wood sheathing directly applied or 6-0-0 oc purlins, except end verticals.
 BOT CHORD Rigid ceiling directly applied or 10-0-0 oc bracing.

REACTIONS.

(size) A=0-5-8, F=0-5-8, E=0-3-8
 Max Horz A=176(LC 9)
 Max Uplift A=-27(LC 6), F=-92(LC 10), E=-70(LC 10)
 Max Grav A=266(LC 16), F=896(LC 16), E=550(LC 16)

FORCES. (lb) - Max. Comp./Max. Ten. - All forces 250 (lb) or less except when shown.

BOT CHORD E-F=-89/343
 WEBS B-F=-447/147, C-F=-345/39, C-E=-411/116

NOTES-

- 1) Wind: ASCE 7-16; Vult=115mph (3-second gust) Vasd=91mph; TCDL=4.2psf; BCDL=5.0psf; h=30ft; Ke=1.00; Cat. II; Exp B; Enclosed; MWFRS (envelope) gable end zone; cantilever left and right exposed ; end vertical left and right exposed; Lumber DOL=1.33 plate grip DOL=1.33
- 2) TCLL: ASCE 7-16; Pf=25.0 psf (Lum DOL = 1.15 Plate DOL = 1.15); Is=1.0; Rough Cat B; Partially Exp.; Ce=1.0; Cs=1.00; Ct=1.10
- 3) Unbalanced snow loads have been considered for this design.
- 4) This truss has been designed for a 10.0 psf bottom chord live load nonconcurrent with any other live loads.
- 5) * This truss has been designed for a live load of 20.0psf on the bottom chord in all areas where a rectangle 3-6-0 tall by 2-0-0 wide will fit between the bottom chord and any other members.
- 6) Provide mechanical connection (by others) of truss to bearing plate capable of withstanding 100 lb uplift at joint(s) A, F, E.
- 7) This truss is designed in accordance with the 2018 International Building Code section 2306.1 and referenced standard ANSI/TPI 1.



September 12, 2024

WARNING - Verify design parameters and READ NOTES ON THIS AND INCLUDED MITEK REFERENCE PAGE MII-7473 rev. 6/30/2020 BEFORE USE.

Design valid for use only with MiTek® connectors. This design is based only upon parameters shown, and is for an individual building component, not a truss system. Before use, the building designer must verify the applicability of design parameters and properly incorporate this design into the overall building design. Bracing indicated is to prevent buckling of individual truss web and/or chord members only. Additional temporary and permanent bracing is always required for stability and to prevent collapse with possible personal injury and property damage. For general guidance regarding the fabrication, storage, delivery, erection and bracing of trusses and truss systems, see

Safety Information available from Truss Plate Institute, 2670 Crain Highway, Suite 203 Waldorf, MD 20601



240 Stirling Crescent
 Bradford, ON. L3Z 4L5

Job	Truss	Truss Type	Qty	Ply	Buildings A-H	U1530847
N0653A	M2	Monopitch	44	1		

Alliance Truss (CA), Abbotsford, BC - V2S 7P6, 8.820 s Aug 30 2024 MiTek Industries, Inc. Thu Sep 12 02:48:09 2024 Page 1

ID:hFyjDMxrTsEK_kgkR0vWWVzFlgc-YHq5Xr57HrC3vBa9G0Xwcje5G3274bb_ze3TxDyeVr4

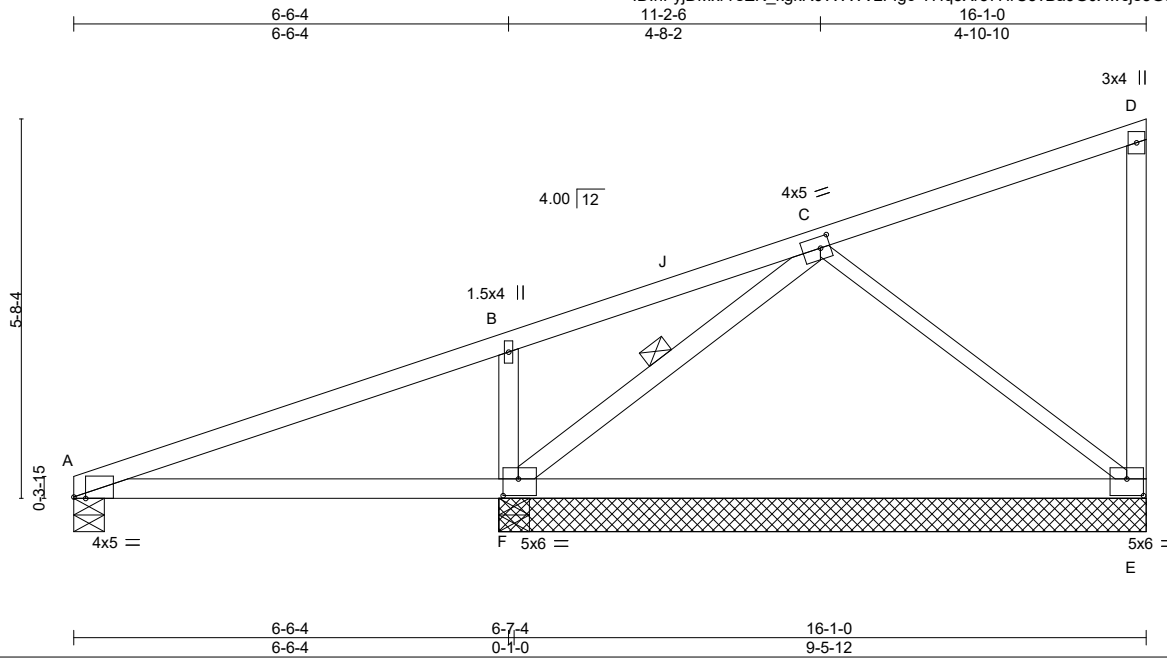

Scale = 1:34.6

Plate Offsets (X,Y)-- [A:0-2-2,Edge], [C:0-1-12,0-2-0], [E:0-3-0,0-3-0], [F:0-2-12,0-3-0]

LOADING (psf)	SPACING-	CSI.	DEFL.	in (loc)	l/defl	L/d	PLATES	GRIP
TCLL 25.0 (Roof Snow=25.0)	2-0-0 Plate Grip DOL 1.15 Lumber DOL 1.15	TC 0.43 BC 0.89 WB 0.87 Matrix-MS	Vert(LL) -0.21 Vert(CT) -0.40 Horz(CT) -0.04 Wind(LL) 0.06	E-F E-F E F-I	>545 >283 n/a >999	360 240 n/a 240	MT20	197/144
TCDL 12.0	Rep Stress Incr YES Code IBC2018/TPI2014						Weight: 57 lb	FT = 20%
BCLL 0.0 *								
BCDL 10.0								

LUMBER-

TOP CHORD 2x4 SPF No.2
 BOT CHORD 2x4 SPF No.2
 WEBS 2x4 SPF No.2 *Except*
 C-E: 2x3 SPF No.2

BRACING-

TOP CHORD Structural wood sheathing directly applied or 4-8-15 oc purlins, except end verticals.
 BOT CHORD Rigid ceiling directly applied.
 WEBS 1 Row at midpt C-F

REACTIONS.

All bearings 0-5-8 except (jt=length) E=9-8-8.
 (lb) - Max Horz A=257(LC 38)
 Max Uplift All uplift 100 lb or less at joint(s) except A=-550(LC 31), F=-1377(LC 31), E=-601(LC 40)
 Max Grav All reactions 250 lb or less at joint(s) except A=635(LC 52), F=1747(LC 28), F=836(LC 1), E=852(LC 27)

FORCES. (lb) - Max. Comp./Max. Ten. - All forces 250 (lb) or less except when shown.

TOP CHORD A-B=-1541/1392, B-C=-1250/1232, C-D=-1290/1209
 BOT CHORD A-F=-1548/1488, E-F=-3159/3153
 WEBS B-F=-446/147, C-F=-2137/2094, C-E=-966/974

NOTES-

- Wind: ASCE 7-16; Vult=115mph (3-second gust) Vasd=91mph; TCDL=4.2psf; BCDL=5.0psf; h=30ft; Ke=1.00; Cat. II; Exp B; Enclosed; MWFRS (envelope) gable end zone; cantilever left and right exposed ; end vertical left and right exposed; Lumber DOL=1.33 plate grip DOL=1.33
- TCLL: ASCE 7-16; Pf=25.0 psf (Lum DOL = 1.15 Plate DOL = 1.15); Is=1.0; Rough Cat B; Partially Exp.; Ce=1.0; Cs=1.00; Ct=1.10
- Unbalanced snow loads have been considered for this design.
- This truss has been designed for a 10.0 psf bottom chord live load nonconcurrent with any other live loads.
- * This truss has been designed for a live load of 20.0psf on the bottom chord in all areas where a rectangle 3-6-0 tall by 2-0-0 wide will fit between the bottom chord and any other members.
- Provide mechanical connection (by others) of truss to bearing plate capable of withstanding 550 lb uplift at joint A, 1377 lb uplift at joint F and 601 lb uplift at joint E.
- This truss is designed in accordance with the 2018 International Building Code section 2306.1 and referenced standard ANSI/TPI 1.
- This truss has been designed for a total drag load of 240 plf. Lumber DOL=(1.33) Plate grip DOL=(1.33) Connect truss to resist drag loads along bottom chord from 6-4-8 to 16-1-0 for 397.6 plf.



September 12, 2024

WARNING - Verify design parameters and READ NOTES ON THIS AND INCLUDED MITEK REFERENCE PAGE MII-7473 rev. 6/30/2020 BEFORE USE.

Design valid for use only with MiTek® connectors. This design is based only upon parameters shown, and is for an individual building component, not a truss system. Before use, the building designer must verify the applicability of design parameters and properly incorporate this design into the overall building design. Bracing indicated is to prevent buckling of individual truss web and/or chord members only. Additional temporary and permanent bracing is always required for stability and to prevent collapse with possible personal injury and property damage. For general guidance regarding the fabrication, storage, delivery, erection and bracing of trusses and truss systems, see

Safety Information available from Truss Plate Institute, 2670 Crain Highway, Suite 203 Waldorf, MD 20601

ANSI/TPI1 Quality Criteria, DSB-89 and BCSI Building Component



240 Stirling Crescent
 Bradford, ON. L3Z 4L5

Job	Truss	Truss Type	Qty	Ply	Buildings A-H	U1530848
N0653A	M3	Monopitch	44	1		

Alliance Truss (CA), Abbotsford, BC - V2S 7P6, 8.820 s Aug 30 2024 MiTek Industries, Inc. Thu Sep 12 02:48:10 2024 Page 1

ID:hFyjDMxrTsEK_kgkR0vWWVzFfgc-1UOTIB6129KvXL8Lqk299xADOSQYp1G8Clp0TfyeVr3

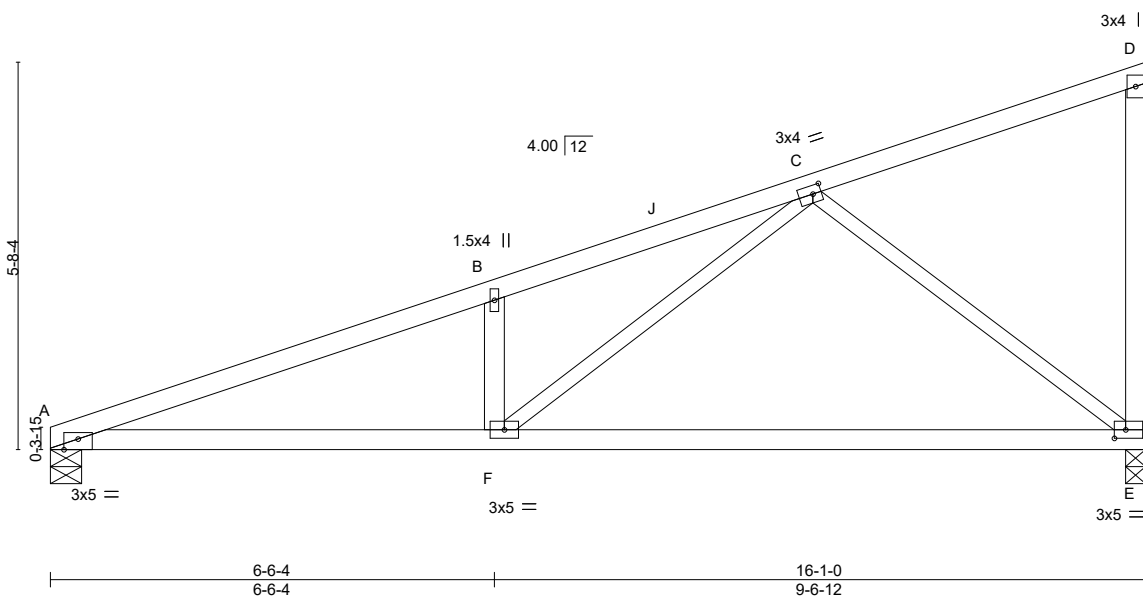

Scale = 1:33.8

Plate Offsets (X,Y)-- [A:0-2-8,Edge], [C:0-1-8,0-1-8], [E:0-2-0,0-1-8]

LOADING (psf)	SPACING-	CSI.	DEFL.	in (loc)	l/defl	L/d	PLATES	GRIP
TCLL 25.0 (Roof Snow=25.0)	2-0-0 Plate Grip DOL 1.15 Lumber DOL 1.15	TC 0.54 BC 0.75 WB 0.90 Matrix-MS	Vert(LL) -0.23 Vert(CT) -0.46 Horz(CT) 0.03 Wind(LL) 0.06	E-F E-F E F-I	>845 >418 n/a >999	360 240 n/a 240	MT20	197/144
TCDL 12.0	Rep Stress Incr YES Code IBC2018/TPI2014						Weight: 55 lb	FT = 20%
BCLL 0.0 *								
BCDL 10.0								

LUMBER-

TOP CHORD 2x4 SPF No.2
 BOT CHORD 2x4 SPF No.2
 WEBS 2x4 SPF No.2 *Except*
 C-F,C-E: 2x3 SPF No.2

BRACING-

TOP CHORD Structural wood sheathing directly applied or 3-6-12 oc purlins, except end verticals.
 BOT CHORD Rigid ceiling directly applied or 10-0-0 oc bracing.

REACTIONS.

(size) A=0-5-8, E=0-3-8
 Max Horz A=176(LC 9)
 Max Uplift A=-81(LC 6), E=-108(LC 10)
 Max Grav A=795(LC 16), E=916(LC 16)

FORCES. (lb) - Max. Comp./Max. Ten. - All forces 250 (lb) or less except when shown.

TOP CHORD A-B=-1739/147, B-C=-1752/205
 BOT CHORD A-F=-176/1607, E-F=-96/806
 WEBS B-F=-423/145, C-F=-103/1029, C-E=-1000/176

NOTES-

- 1) Wind: ASCE 7-16; Vult=115mph (3-second gust) Vasd=91mph; TCDL=4.2psf; BCDL=5.0psf; h=30ft; Ke=1.00; Cat. II; Exp B; Enclosed; MWFRS (envelope) gable end zone; cantilever left and right exposed; end vertical left and right exposed; Lumber DOL=1.33 plate grip DOL=1.33
- 2) TCLL: ASCE 7-16; Pf=25.0 psf (Lum DOL = 1.15 Plate DOL = 1.15); Is=1.0; Rough Cat B; Partially Exp.; Ce=1.0; Cs=1.00; Ct=1.10
- 3) Unbalanced snow loads have been considered for this design.
- 4) This truss has been designed for a 10.0 psf bottom chord live load nonconcurrent with any other live loads.
- 5) * This truss has been designed for a live load of 20.0psf on the bottom chord in all areas where a rectangle 3-6-0 tall by 2-0-0 wide will fit between the bottom chord and any other members.
- 6) Provide mechanical connection (by others) of truss to bearing plate capable of withstanding 81 lb uplift at joint A and 108 lb uplift at joint E.
- 7) This truss is designed in accordance with the 2018 International Building Code section 2306.1 and referenced standard ANSI/TPI 1.



September 12, 2024

WARNING - Verify design parameters and READ NOTES ON THIS AND INCLUDED MITEK REFERENCE PAGE MII-7473 rev. 6/30/2020 BEFORE USE.

Design valid for use only with MiTek® connectors. This design is based only upon parameters shown, and is for an individual building component, not a truss system. Before use, the building designer must verify the applicability of design parameters and properly incorporate this design into the overall building design. Bracing indicated is to prevent buckling of individual truss web and/or chord members only. Additional temporary and permanent bracing is always required for stability and to prevent collapse with possible personal injury and property damage. For general guidance regarding the fabrication, storage, delivery, erection and bracing of trusses and truss systems, see

Safety Information available from Truss Plate Institute, 2670 Crain Highway, Suite 203 Waldorf, MD 20601



240 Stirling Crescent
 Bradford, ON. L3Z 4L5

Job	Truss	Truss Type	Qty	Ply	Buildings A-H	U1530849
N0653A	M4	MONOPITCH	4	1		

Alliance Truss (CA), Abbotsford, BC - V2S 7P6, 8.820 s Aug 30 2024 MiTek Industries, Inc. Thu Sep 12 02:48:10 2024 Page 1

ID:hFyjDMxrTsEK_kgkR0vWWVzFlgc-1UOTIB6I29KvXL8Lqk299xADHSPAp468Clp0TfyeVr3

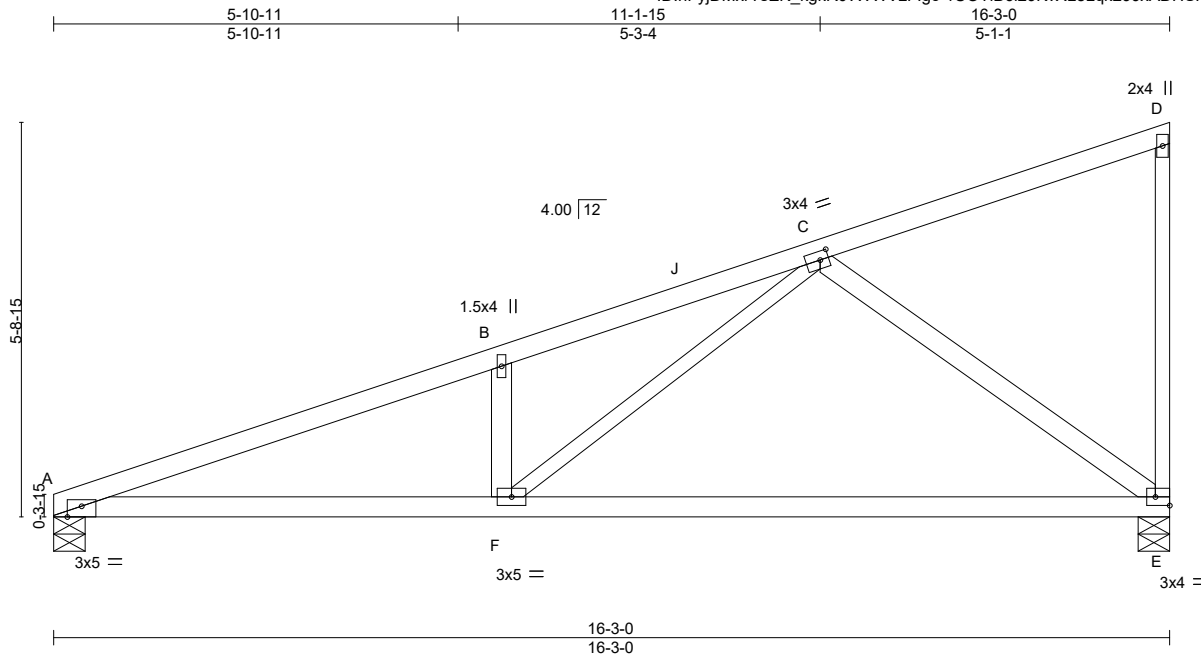

Plate Offsets (X,Y)-- [A:0-2-8,Edge], [C:0-1-8,0-1-8], [E:Edge,0-1-8]

LOADING (psf)	SPACING-	CSI.	DEFL.	in (loc)	l/defl	L/d	PLATES	GRIP
TCLL 25.0 (Roof Snow=25.0)	2-0-0 Plate Grip DOL 1.15	TC 0.54	Vert(LL)	-0.27	E-F	>725	MT20	197/144
TCDL 12.0	Lumber DOL 1.15	BC 0.78	Vert(CT)	-0.54	E-F	>360		
BCLL 0.0 *	Rep Stress Incr YES	WB 0.72	Horz(CT)	0.03	E	n/a		
BCDL 10.0	Code IBC2018/TPI2014	Matrix-MS	Wind(LL)	0.06	F-I	>999		
							Weight: 56 lb	FT = 20%

LUMBER-

TOP CHORD 2x4 SPF No.2
 BOT CHORD 2x4 SPF No.2
 WEBS 2x4 SPF No.2 *Except*
 D-E,C-F: 2x3 SPF No.2

BRACING-

TOP CHORD Structural wood sheathing directly applied or 3-6-3 oc purlins, except end verticals.
 BOT CHORD Rigid ceiling directly applied or 10-0-0 oc bracing.

REACTIONS.

(size) A=0-5-8, E=0-5-8
 Max Horz A=163(LC 6)
 Max Uplift A=-68(LC 6), E=-123(LC 6)
 Max Grav A=804(LC 16), E=927(LC 16)

FORCES. (lb) - Max. Comp./Max. Ten. - All forces 250 (lb) or less except when shown.

TOP CHORD A-B=-1770/100, B-C=-1778/157
 BOT CHORD A-F=-216/1635, E-F=-146/846
 WEBS B-F=-413/142, C-F=-90/1024, C-E=-1040/186

NOTES-

- 1) Wind: ASCE 7-16; Vult=115mph (3-second gust) Vasd=91mph; TCDL=4.2psf; BCDL=5.0psf; h=30ft; Ke=1.00; Cat. II; Exp B; Enclosed; MWFRS (envelope) gable end zone; cantilever left exposed ; end vertical left exposed; Lumber DOL=1.33 plate grip DOL=1.33
- 2) TCLL: ASCE 7-16; Pf=25.0 psf (Lum DOL = 1.15 Plate DOL = 1.15); Is=1.0; Rough Cat B; Partially Exp.; Ce=1.0; Cs=1.00; Ct=1.10
- 3) Unbalanced snow loads have been considered for this design.
- 4) This truss has been designed for a 10.0 psf bottom chord live load nonconcurrent with any other live loads.
- 5) * This truss has been designed for a live load of 20.0psf on the bottom chord in all areas where a rectangle 3-6-0 tall by 2-0-0 wide will fit between the bottom chord and any other members.
- 6) Provide mechanical connection (by others) of truss to bearing plate capable of withstanding 68 lb uplift at joint A and 123 lb uplift at joint E.
- 7) This truss is designed in accordance with the 2018 International Building Code section 2306.1 and referenced standard ANSI/TPI 1.



September 12, 2024

WARNING - Verify design parameters and READ NOTES ON THIS AND INCLUDED MITEK REFERENCE PAGE MII-7473 rev. 6/30/2020 BEFORE USE.

Design valid for use only with MiTek® connectors. This design is based only upon parameters shown, and is for an individual building component, not a truss system. Before use, the building designer must verify the applicability of design parameters and properly incorporate this design into the overall building design. Bracing indicated is to prevent buckling of individual truss web and/or chord members only. Additional temporary and permanent bracing is always required for stability and to prevent collapse with possible personal injury and property damage. For general guidance regarding the fabrication, storage, delivery, erection and bracing of trusses and truss systems, see

Safety Information available from Truss Plate Institute, 2670 Crain Highway, Suite 203 Waldorf, MD 20601



240 Stirling Crescent
 Bradford, ON. L3Z 4L5

Job	Truss	Truss Type	Qty	Ply	Buildings A-H	U1530850
N0653A	M5	Monopitch Structural Gable	4	1		

Alliance Truss (CA), Abbotsford, BC - V2S 7P6, 8.820 s Aug 30 2024 MiTek Industries, Inc. Thu Sep 12 02:48:11 2024 Page 1

ID:hFyjDMxrTsEK_kgkR0vWwVzFlgc-VgxryX7NpTSM8VjYORZO8jPfskYelHRyYa?5yeVr2

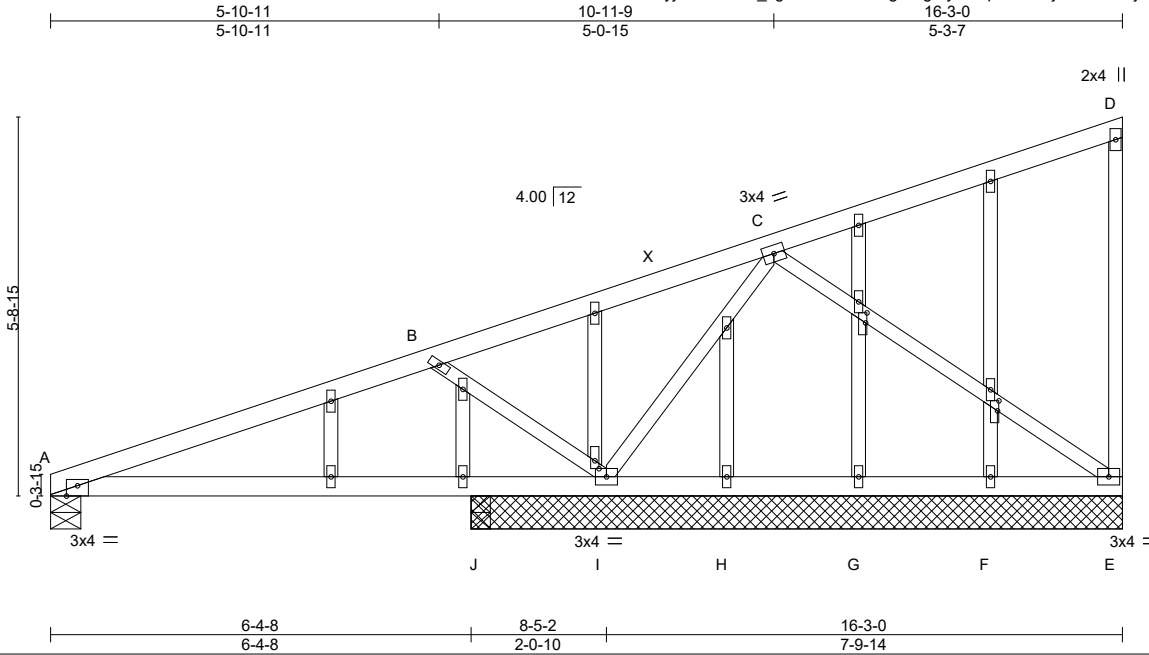

Scale = 1:34.9

Plate Offsets (X,Y)-- [A:0-2-0,Edge], [I:0-1-7,0-0-12], [L:0-1-13,0-0-4], [N:0-1-13,0-0-4]

LOADING (psf)	SPACING-	CSI.	DEFL.	in (loc)	l/defl	L/d	PLATES	GRIP
TCLL 25.0 (Roof Snow=25.0)	2-0-0	TC 0.50	Vert(LL)	-0.04	J-W	>999	MT20	197/144
TCDL 12.0	Lumber DOL 1.15	BC 0.34	Vert(CT)	-0.09	J-W	>836		
BCLL 0.0 *	Rep Stress Incr YES	WB 0.31	Horz(CT)	0.01	E	n/a		
BCDL 10.0	Code IBC2018/TPI2014	Matrix-MS	Wind(LL)	0.03	J-W	>999	Weight: 66 lb	FT = 20%

LUMBER-

TOP CHORD 2x4 SPF No.2
 BOT CHORD 2x4 SPF No.2
 WEBS 2x3 SPF No.2
 OTHERS 2x3 SPF No.2

BRACING-

TOP CHORD Structural wood sheathing directly applied or 6-0-0 oc purlins, except end verticals.
 BOT CHORD Rigid ceiling directly applied or 10-0-0 oc bracing.

REACTIONS.

All bearings 9-10-8 except (jt=length) A=0-5-8, J=0-3-8.
 (lb) - Max Horz A=178(LC 9)
 Max Uplift All uplift 100 lb or less at joint(s) A, E except I=185(LC 10)
 Max Grav All reactions 250 lb or less at joint(s) F, G, H except A=305(LC 1), I=722(LC 16), E=369(LC 16), J=271(LC 5)

FORCES. (lb) - Max. Comp./Max. Ten. - All forces 250 (lb) or less except when shown.

TOP CHORD A-B=-281/29, B-C=-103/253
 WEBS B-I=-498/156, C-I=-607/128

NOTES-

- 1) Wind: ASCE 7-16; Vult=115mph (3-second gust) Vasd=91mph; TCDL=4.2psf; BCDL=5.0psf; h=30ft; Ke=1.00; Cat. II; Exp B; Enclosed; MWFRS (envelope) gable end zone; cantilever left and right exposed; end vertical left and right exposed; Lumber DOL=1.33 plate grip DOL=1.33
- 2) Truss designed for wind loads in the plane of the truss only. For studs exposed to wind (normal to the face), see Standard Industry Gable End Details as applicable, or consult qualified building designer as per ANSI/TPI 1.
- 3) TCLL: ASCE 7-16; Pf=25.0 psf (Lum DOL = 1.15 Plate DOL = 1.15); Is=1.0; Rough Cat B; Partially Exp.; Ce=1.0; Cs=1.00; Ct=1.10
- 4) Unbalanced snow loads have been considered for this design.
- 5) All plates are 1.5x4 MT20 unless otherwise indicated.
- 6) Gable studs spaced at 2-0-0 oc.
- 7) This truss has been designed for a 10.0 psf bottom chord live load nonconcurrent with any other live loads.
- 8) * This truss has been designed for a live load of 20.0psf on the bottom chord in all areas where a rectangle 3-6-0 tall by 2-0-0 wide will fit between the bottom chord and any other members.
- 9) Provide mechanical connection (by others) of truss to bearing plate capable of withstanding 100 lb uplift at joint(s) A, E except (jt=length) I=185.
- 10) This truss is designed in accordance with the 2018 International Building Code section 2306.1 and referenced standard ANSI/TPI 1.



September 12, 2024

WARNING - Verify design parameters and READ NOTES ON THIS AND INCLUDED MITEK REFERENCE PAGE MII-7473 rev. 6/30/2020 BEFORE USE.

Design valid for use only with MiTek® connectors. This design is based only upon parameters shown, and is for an individual building component, not a truss system. Before use, the building designer must verify the applicability of design parameters and properly incorporate this design into the overall building design. Bracing indicated is to prevent buckling of individual truss web and/or chord members only. Additional temporary and permanent bracing is always required for stability and to prevent collapse with possible personal injury and property damage. For general guidance regarding the fabrication, storage, delivery, erection and bracing of trusses and truss systems, see **ANSI/TPI1 Quality Criteria, DSB-89 and BCSI Building Component Safety Information** available from Truss Plate Institute, 2670 Crain Highway, Suite 203 Waldorf, MD 20601



240 Stirling Crescent
 Bradford, ON. L3Z 4L5

Job	Truss	Truss Type	Qty	Ply	Buildings A-H	U1530851
N0653A	M6	MONOPITCH	4	1		

Alliance Truss (CA), Abbotsford, BC - V2S 7P6, 8.820 s Aug 30 2024 MiTek Industries, Inc. Thu Sep 12 02:48:11 2024 Page 1
 ID:hFyjDMxrTsEK_kgkR0vWWVzF1gc-VgxryX7NpTsm8VjYORZO8jP1sn3YWDHRYa?5yeVr2
 5-10-11 10-11-9 5-0-15 16-3-0 5-3-7

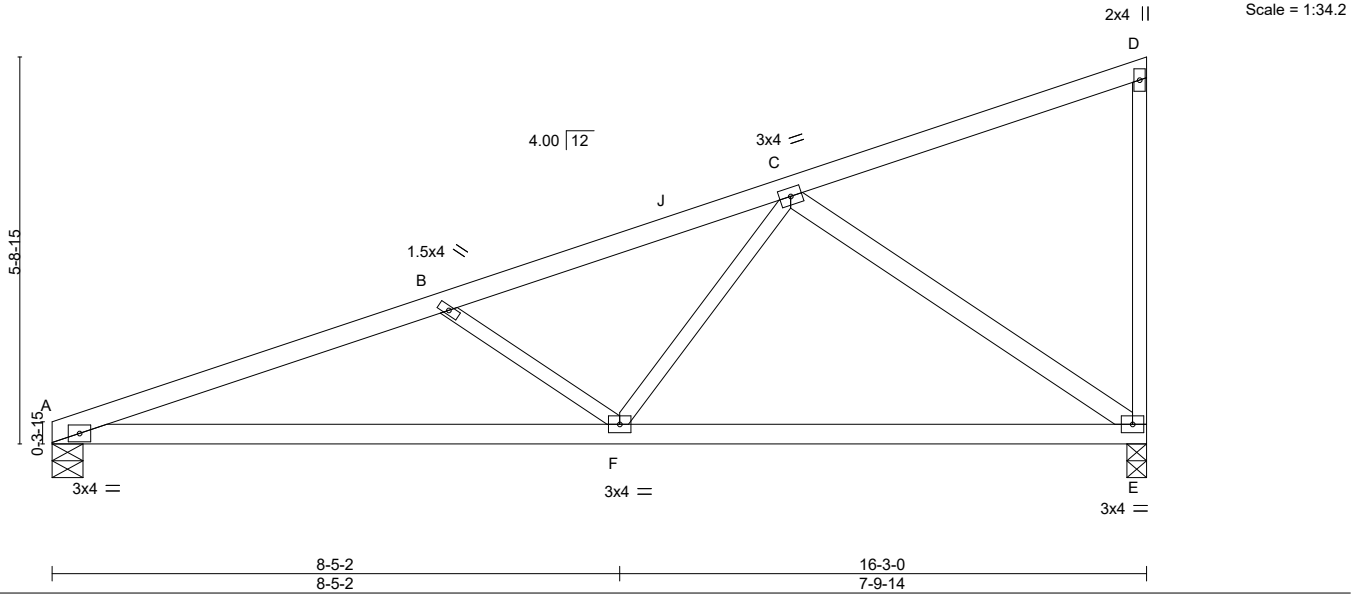

LOADING (psf)	SPACING-	CSI.	DEFL.	PLATES	GRIP
TCLL 25.0	2-0-0	TC 0.48	in (loc) l/defl L/d	MT20	197/144
(Roof Snow=25.0)	Plate Grip DOL 1.15	BC 0.67	Vert(LL) -0.10 F-I >999 360		
TCDL 12.0	Lumber DOL 1.15	WB 0.79	Vert(CT) -0.22 F-I >876 240		
BCLL 0.0 *	Rep Stress Incr YES	Matrix-MS	Horz(CT) 0.03 E n/a n/a	Weight: 55 lb	FT = 20%
BCDL 10.0	Code IBC2018/TPI2014		Wind(LL) 0.06 F-I >999 240		

LUMBER-
 TOP CHORD 2x4 SPF No.2
 BOT CHORD 2x4 SPF No.2
 WEBS 2x3 SPF No.2 *Except*
 C-E: 2x4 SPF No.2

BRACING-
 TOP CHORD Structural wood sheathing directly applied or 3-8-11 oc purlins, except end verticals.
 BOT CHORD Rigid ceiling directly applied or 10-0-0 oc bracing.

REACTIONS. (size) A=0-5-8, E=0-3-8
 Max Horz A=163(LC 6)
 Max Uplift A=-68(LC 6), E=-123(LC 6)
 Max Grav A=804(LC 16), E=927(LC 16)

FORCES. (lb) - Max. Comp./Max. Ten. - All forces 250 (lb) or less except when shown.
 TOP CHORD A-B=-1762/150, B-C=-1370/76
 BOT CHORD A-F=-267/1643, E-F=-143/909
 WEBS B-F=-502/150, C-F=-4/597, C-E=-1101/175

- NOTES-**
- 1) Wind: ASCE 7-16; Vult=115mph (3-second gust) Vasd=91mph; TCDL=4.2psf; BCDL=5.0psf; h=30ft; Ke=1.00; Cat. II; Exp B; Enclosed; MWFRS (envelope) gable end zone; cantilever left exposed ; end vertical left exposed; Lumber DOL=1.33 plate grip DOL=1.33
 - 2) TCLL: ASCE 7-16; Pf=25.0 psf (Lum DOL = 1.15 Plate DOL = 1.15); Is=1.0; Rough Cat B; Partially Exp.; Ce=1.0; Cs=1.00; Ct=1.10
 - 3) Unbalanced snow loads have been considered for this design.
 - 4) This truss has been designed for a 10.0 psf bottom chord live load nonconcurrent with any other live loads.
 - 5) * This truss has been designed for a live load of 20.0psf on the bottom chord in all areas where a rectangle 3-6-0 tall by 2-0-0 wide will fit between the bottom chord and any other members.
 - 6) Provide mechanical connection (by others) of truss to bearing plate capable of withstanding 100 lb uplift at joint(s) A except (jt=lb) E=123.
 - 7) This truss is designed in accordance with the 2018 International Building Code section 2306.1 and referenced standard ANSI/TPI 1.



September 12, 2024

Job	Truss	Truss Type	Qty	Ply	Buildings A-H	U1530852
N0653A	N1	MONOPITCH SUPPORTED	48	1		

Alliance Truss (CA), Abbotsford, BC - V2S 7P6, 8.820 s Aug 30 2024 MiTek Industries, Inc. Thu Sep 12 02:48:12 2024 Page 1
 ID:hFyjDMxrTsEK_kgkR0vWWVzFgC-zsVDA8?amadmflky94dEMGdCGFgH9ZQfcl7YYeVr1

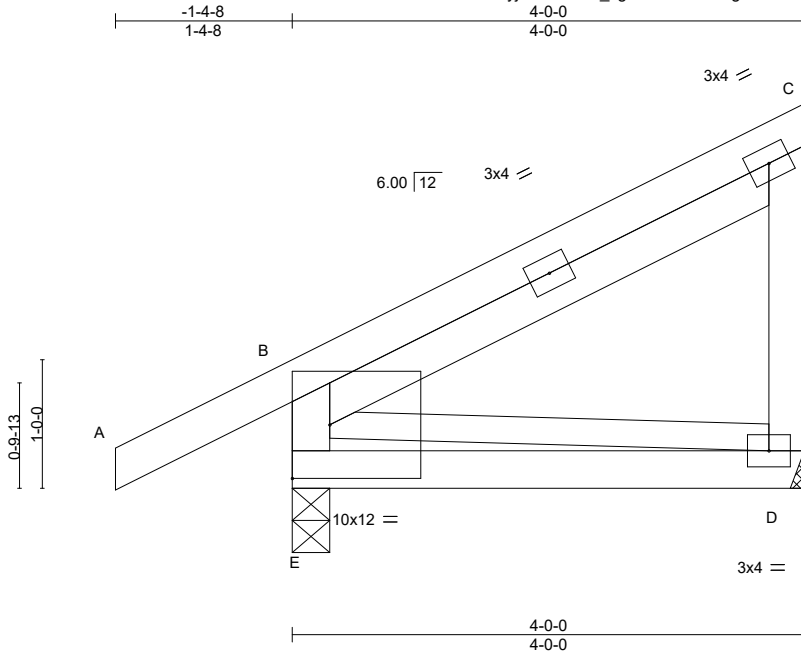

Scale = 1:17.9

LOADING (psf)	SPACING-	CSI.	DEFL.	PLATES	GRIP
TCLL 25.0	2-0-0	TC 0.26	in (loc) l/defl L/d	MT20	197/144
(Roof Snow=25.0)	Plate Grip DOL 1.15	BC 0.14	Vert(LL) -0.01 D-E >999 360		
TCDL 12.0	Lumber DOL 1.15	WB 0.02	Vert(CT) -0.02 D-E >999 240		
BCLL 0.0 *	Rep Stress Incr YES	Matrix-MP	Horz(CT) -0.00 D n/a n/a		
BCDL 10.0	Code IBC2018/TPI2014		Wind(LL) 0.00 E **** 240	Weight: 22 lb	FT = 20%

LUMBER-

TOP CHORD 2x4 SPF No.2
 BOT CHORD 2x4 SPF No.2
 WEBS 2x4 SPF No.2 *Except*
 B-D: 2x3 SPF No.2

BRACING-

TOP CHORD Structural wood sheathing directly applied or 4-0-0 oc purlins, except end verticals.
 BOT CHORD Rigid ceiling directly applied or 6-0-0 oc bracing.

REACTIONS.

(size) E=0-3-8, D=Mechanical
 Max Horz E=87(LC 7)
 Max Uplift E=-41(LC 10), D=-30(LC 10)
 Max Grav E=450(LC 17), D=210(LC 17)

FORCES. (lb) - Max. Comp./Max. Ten. - All forces 250 (lb) or less except when shown.

TOP CHORD B-E=-414/59

NOTES-

- 1) Wind: ASCE 7-16; Vult=115mph (3-second gust) Vasd=91mph; TCDL=4.2psf; BCDL=5.0psf; h=30ft; Ke=1.00; Cat. II; Exp B; Enclosed; MWFRS (envelope) gable end zone; cantilever left and right exposed ; end vertical left and right exposed; Lumber DOL=1.33 plate grip DOL=1.33
- 2) TCLL: ASCE 7-16; Pf=25.0 psf (Lum DOL = 1.15 Plate DOL = 1.15); Is=1.0; Rough Cat B; Partially Exp.; Ce=1.0; Cs=1.00; Ct=1.10
- 3) Unbalanced snow loads have been considered for this design.
- 4) This truss has been designed for greater of min roof live load of 18.0 psf or 2.00 times flat roof load of 25.0 psf on overhangs non-concurrent with other live loads.
- 5) This truss has been designed for a 10.0 psf bottom chord live load nonconcurrent with any other live loads.
- 6) * This truss has been designed for a live load of 20.0psf on the bottom chord in all areas where a rectangle 3-6-0 tall by 2-0-0 wide will fit between the bottom chord and any other members.
- 7) Refer to girder(s) for truss to truss connections.
- 8) Provide mechanical connection (by others) of truss to bearing plate capable of withstanding 100 lb uplift at joint(s) E, D.
- 9) This truss is designed in accordance with the 2018 International Building Code section 2306.1 and referenced standard ANSI/TPI 1.



September 12, 2024

WARNING - Verify design parameters and READ NOTES ON THIS AND INCLUDED MITEK REFERENCE PAGE MII-7473 rev. 6/30/2020 BEFORE USE.

Design valid for use only with MiTek® connectors. This design is based only upon parameters shown, and is for an individual building component, not a truss system. Before use, the building designer must verify the applicability of design parameters and properly incorporate this design into the overall building design. Bracing indicated is to prevent buckling of individual truss web and/or chord members only. Additional temporary and permanent bracing is always required for stability and to prevent collapse with possible personal injury and property damage. For general guidance regarding the fabrication, storage, delivery, erection and bracing of trusses and truss systems, see

Safety Information available from Truss Plate Institute, 2670 Crain Highway, Suite 203 Waldorf, MD 20601



240 Stirling Crescent
 Bradford, ON. L3Z 4L5

Job	Truss	Truss Type	Qty	Ply	Buildings A-H	U1530853
N0653A	N2	MONOPITCH	120	1		

Alliance Truss (CA), Abbotsford, BC - V2S 7P6,

8.820 s Aug 30 2024 MiTek Industries, Inc. Thu Sep 12 02:48:12 2024 Page 1

ID:hFyjDMxrTsEK_kgkR0vWWVzFgczsVDAat8?amadmflky94dEMGZIGEMH9VQfci7YYeVr1

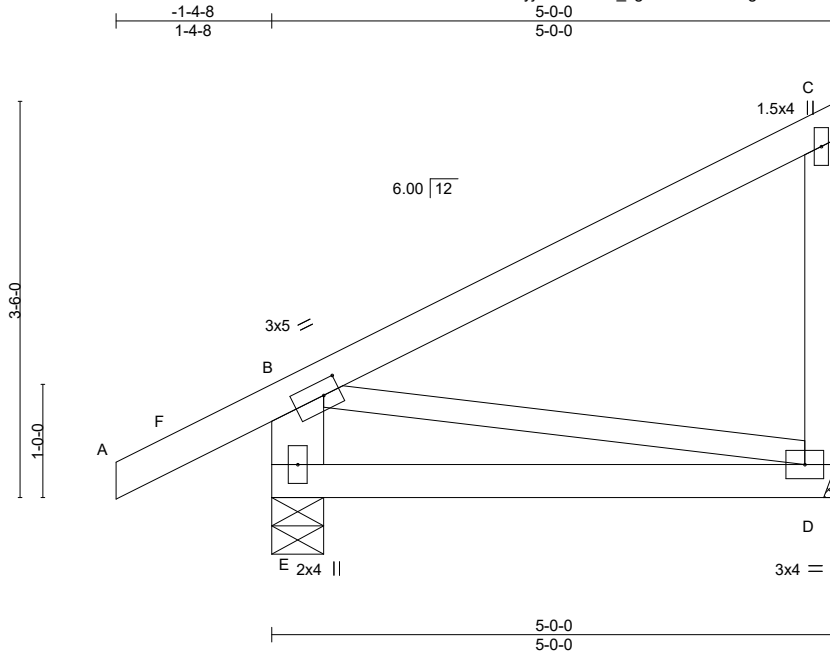

Scale = 1:20.4

Plate Offsets (X,Y)-- [B:0-1-12,0-1-8]

LOADING (psf)	SPACING-	CSI.	DEFL.	in (loc)	l/defl	L/d	PLATES	GRIP
TCLL 25.0 (Roof Snow=25.0)	2-0-0 Plate Grip DOL 1.15	TC 0.54	Vert(LL)	-0.03	D-E	>999	MT20	197/144
TCDL 12.0	Lumber DOL 1.15	BC 0.22	Vert(CT)	-0.05	D-E	>999		
BCLL 0.0 *	Rep Stress Incr YES	WB 0.02	Horz(CT)	-0.00	D	n/a		
BCDL 10.0	Code IBC2018/TPI2014	Matrix-MP	Wind(LL)	0.00	E	****	Weight: 22 lb	FT = 20%

LUMBER-

TOP CHORD 2x4 SPF No.2
 BOT CHORD 2x4 SPF No.2
 WEBS 2x4 SPF No.2 *Except*
 B-E: 2x6 SPF No.2, B-D: 2x3 SPF No.2

BRACING-

TOP CHORD Structural wood sheathing directly applied or 5-0-0 oc purlins, except end verticals.
 BOT CHORD Rigid ceiling directly applied or 10-0-0 oc bracing.

REACTIONS.

(size) D=Mechanical, E=0-5-8
 Max Horz E=105(LC 7)
 Max Uplift D=-38(LC 10), E=-45(LC 10)
 Max Grav D=281(LC 17), E=485(LC 17)

FORCES. (lb) - Max. Comp./Max. Ten. - All forces 250 (lb) or less except when shown.

TOP CHORD B-E=-439/68

NOTES-

- 1) Wind: ASCE 7-16; Vult=115mph (3-second gust) Vasd=91mph; TCDL=4.2psf; BCDL=5.0psf; h=30ft; Ke=1.00; Cat. II; Exp B; Enclosed; MWFRS (envelope) gable end zone; cantilever left and right exposed ; end vertical left and right exposed; Lumber DOL=1.33 plate grip DOL=1.33
- 2) TCLL: ASCE 7-16; Pf=25.0 psf (Lum DOL = 1.15 Plate DOL = 1.15); Is=1.0; Rough Cat B; Partially Exp.; Ce=1.0; Cs=1.00; Ct=1.10
- 3) Unbalanced snow loads have been considered for this design.
- 4) This truss has been designed for greater of min roof live load of 18.0 psf or 2.00 times flat roof load of 25.0 psf on overhangs non-concurrent with other live loads.
- 5) This truss has been designed for a 10.0 psf bottom chord live load nonconcurrent with any other live loads.
- 6) * This truss has been designed for a live load of 20.0psf on the bottom chord in all areas where a rectangle 3-6-0 tall by 2-0-0 wide will fit between the bottom chord and any other members.
- 7) Refer to girder(s) for truss to truss connections.
- 8) Provide mechanical connection (by others) of truss to bearing plate capable of withstanding 100 lb uplift at joint(s) D, E.
- 9) This truss is designed in accordance with the 2018 International Building Code section 2306.1 and referenced standard ANSI/TPI 1.



September 12, 2024

WARNING - Verify design parameters and READ NOTES ON THIS AND INCLUDED MITEK REFERENCE PAGE MII-7473 rev. 6/30/2020 BEFORE USE.

Design valid for use only with MiTek® connectors. This design is based only upon parameters shown, and is for an individual building component, not a truss system. Before use, the building designer must verify the applicability of design parameters and properly incorporate this design into the overall building design. Bracing indicated is to prevent buckling of individual truss web and/or chord members only. Additional temporary and permanent bracing is always required for stability and to prevent collapse with possible personal injury and property damage. For general guidance regarding the fabrication, storage, delivery, erection and bracing of trusses and truss systems, see

ANSI/TPI1 Quality Criteria, DSB-89 and BCSI Building Component

Safety Information available from Truss Plate Institute, 2670 Crain Highway, Suite 203 Waldorf, MD 20601



240 Stirling Crescent
 Bradford, ON. L3Z 4L5

Job	Truss	Truss Type	Qty	Ply	Buildings A-H	U1530854
N0653A	P1	GABLE	7	1		

Alliance Truss (CA), Abbotsford, BC - V2S 7P6, 8.820 s Aug 30 2024 MiTek Industries, Inc. Thu Sep 12 02:48:14 2024 Page 1
 ID:hFyjDMxrTsEK_kgkR0vWWVzFlgc-vFd_bZ9G6OqL?zS73Z65JnLs14pLlqDj7wnEcQyeVr?

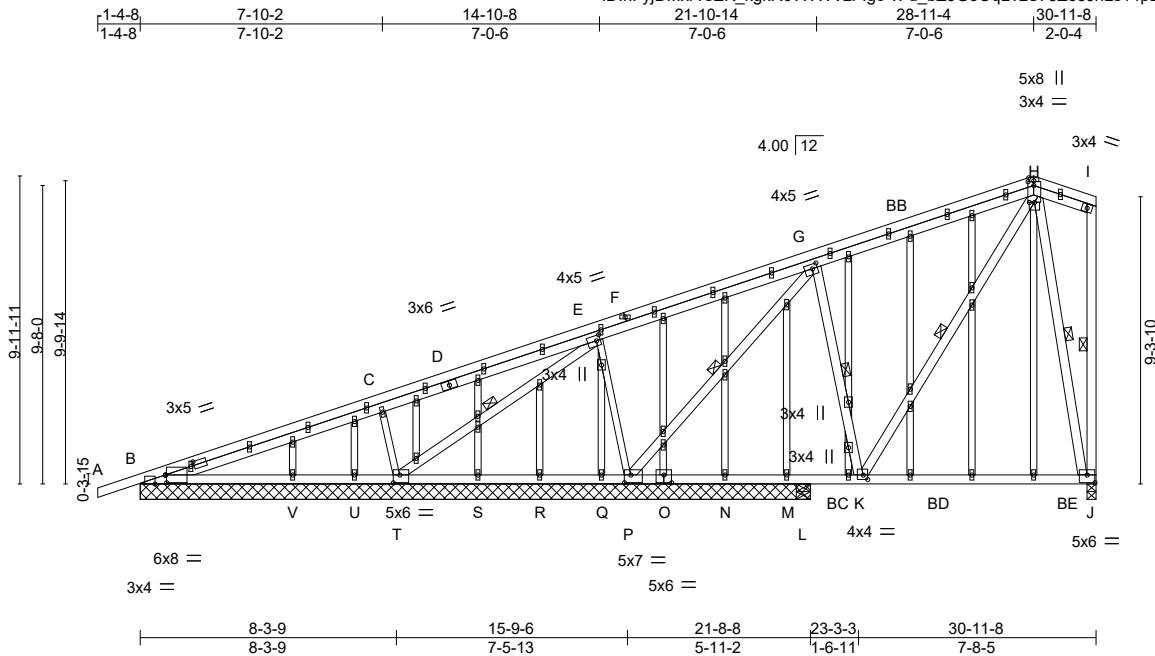

Scale = 1:74.6

Plate Offsets (X,Y)-- [B:0-0-7,0-3-0], [B:0-11-12,0-1-8], [B:0-4-0,Edge], [E:0-1-8,0-2-0], [G:0-2-0,0-1-12], [H:0-1-8,0-2-4], [H:0-2-0,0-0-0], [H:0-2-0,Edge], [J:0-3-0,0-3-0], [K:0-1-12,0-1-12], [O:0-3-0,0-3-0], [P:0-2-8,0-3-0], [T:0-2-8,0-3-0]

LOADING (psf)	SPACING-	CSI.	DEFL.	in (loc)	l/defl	L/d	PLATES	GRIP
TCLL 25.0	2-0-0	TC 0.75	Vert(LL)	-0.16	J-K	>692	MT20	197/144
(Roof Snow=25.0)	Plate Grip DOL 1.15	BC 0.64	Vert(CT)	-0.26	J-K	>432		
TCDL 12.0	Lumber DOL 1.15	WB 0.97	Horz(CT)	-0.02	N	n/a		
BCLL 0.0 *	Rep Stress Incr YES	Matrix-MS	Wind(LL)	0.04	V-BA	>999		
BCDL 10.0	Code IBC2018/TPI2014						Weight: 226 lb	FT = 20%

LUMBER-

TOP CHORD 2x4 SPF No.2
 BOT CHORD 2x4 SPF No.2
 WEBS 2x4 SPF No.2 *Except*
 C-T,E-P: 2x3 SPF No.2
 OTHERS 2x3 SPF No.2

BRACING-

TOP CHORD Structural wood sheathing directly applied or 3-3-3 oc purlins, except end verticals.
 BOT CHORD Rigid ceiling directly applied or 3-9-8 oc bracing.
 WEBS 1 Row at midpt E-T, G-P, G-K, H-K, I-J, H-J

REACTIONS.

All bearings 21-8-8 except (jt=length) J=0-3-8, L=0-5-8.
 (lb) - Max Horz B=754(LC 35)
 Max Uplift All uplift 100 lb or less at joint(s) M, U, V except B=-1006(LC 32), T=-1651(LC 40), P=-1094(LC 32), J=-1170(LC 33), L=-198(LC 19)
 Max Grav All reactions 250 lb or less at joint(s) M, N, Q, R, S, U, L except B=1117(LC 27), T=1750(LC 53), P=1693(LC 29), J=1557(LC 26), V=330(LC 26), B=481(LC 1)

FORCES. (lb) - Max. Comp./Max. Ten. - All forces 250 (lb) or less except when shown.

TOP CHORD B-C=-2932/2749, C-E=-966/930, E-G=-1569/1477, G-H=-1624/1472, H-I=-529/553
 BOT CHORD B-V=-2174/2051, U-V=-1082/954, T-U=-393/270, S-T=-1915/1800, R-S=-1022/908, Q-R=-592/477, P-Q=-891/776, N-P=-903/1006, M-N=-1023/1097, L-M=-1209/1282, K-L=-1209/1282, J-K=-293/295
 WEBS C-T=-539/202, E-T=-2562/2500, E-P=-943/931, G-P=-2452/2236, G-K=-1136/1260, H-K=-1336/1472, H-J=-1456/1228

NOTES-

- 1) Wind: ASCE 7-16; Vult=115mph (3-second gust) Vasd=91mph; TCDL=4.2psf; BCDL=5.0psf; h=30ft; Ke=1.00; Cat. II; Exp B; Enclosed; MWFRS (envelope) gable end zone; cantilever left and right exposed ; end vertical left and right exposed; Lumber DOL=1.33 plate grip DOL=1.33
- 2) Truss designed for wind loads in the plane of the truss only. For studs exposed to wind (normal to the face), see Standard Industry Gable End Details as applicable, or consult qualified building designer as per ANSI/TPI 1.
- 3) TCLL: ASCE 7-16; Pf=25.0 psf (Lum DOL = 1.15 Plate DOL = 1.15); ls=1.0; Rough Cat B; Partially Exp.; Ce=1.0; Cs=1.00; Ct=1.10
- 4) Unbalanced snow loads have been considered for this design.
- 5) This truss has been designed for greater of min roof live load of 20.0 psf or 2.00 times flat roof load of 25.0 psf on overhangs non-concurrent with other live loads.
- 6) All plates are 1.5x4 MT20 unless otherwise indicated.
- 7) Gable studs spaced at 2-0-0 oc.
- 8) This truss has been designed for a 10.0 psf bottom chord live load nonconcurrent with any other live loads.
- 9) * This truss has been designed for a live load of 20.0psf on the bottom chord in all areas where a rectangle 3-6-0 tall by 2-0-0 wide will fit between the bottom chord and any other members, with BCDL = 10.0psf.
- 10) Provide mechanical connection (by others) of truss to bearing plate capable of withstanding 100 lb uplift at joint(s) M, U, V except (jt=lb) B=1006, T=1651, P=1094, J=1170, L=198, B=1006.



September 12, 2024

Continued on page 2

WARNING - Verify design parameters and READ NOTES ON THIS AND INCLUDED MITEK REFERENCE PAGE MII-7473 rev. 6/30/2020 BEFORE USE.

Design valid for use only with MiTek® connectors. This design is based only upon parameters shown, and is for an individual building component, not a truss system. Before use, the building designer must verify the applicability of design parameters and properly incorporate this design into the overall building design. Bracing indicated is to prevent buckling of individual truss web and/or chord members only. Additional temporary and permanent bracing is always required for stability and to prevent collapse with possible personal injury and property damage. For general guidance regarding the fabrication, storage, delivery, erection and bracing of trusses and truss systems, see

Safety Information available from Truss Plate Institute, 2670 Crain Highway, Suite 203 Waldorf, MD 20601



240 Stirling Crescent
 Bradford, ON. L3Z 4L5

Job	Truss	Truss Type	Qty	Ply	Buildings A-H
N0653A	P1	GABLE	7	1	U1530854

Alliance Truss (CA), Abbotsford, BC - V2S 7P6,

8.820 s Aug 30 2024 MiTek Industries, Inc. Thu Sep 12 02:48:14 2024 Page 2
 ID:hFyjDMxrTsEK_kgkR0vWWVzFlgc-vFd_bZ9G6OqL?zS73Z65JnLs14pLqDj7wnEcQyeVr?

NOTES-

- 11) This truss is designed in accordance with the 2018 International Building Code section 2306.1 and referenced standard ANSI/TPI 1.
- 12) This truss has been designed for a total drag load of 240 plf. Lumber DOL=(1.33) Plate grip DOL=(1.33) Connect truss to resist drag loads along bottom chord from 0-0-0 to 21-8-8 for 342.3 plf.
- 13) No notches allowed in overhang and 10408 from left end and 0 from right end or 12" along rake from scarf, whichever is larger. Minimum 1.5x4 tie plates required at 2-0-0 o.c. maximum between the stacking chords. For edge-wise notching, provide at least one tie plate between each notch.



WARNING - Verify design parameters and READ NOTES ON THIS AND INCLUDED MITEK REFERANCE PAGE MII-7473 rev. 6/30/2020 BEFORE USE.

Design valid for use only with MiTek® connectors. This design is based only upon parameters shown, and is for an individual building component, not a truss system. Before use, the building designer must verify the applicability of design parameters and properly incorporate this design into the overall building design. Bracing indicated is to prevent buckling of individual truss web and/or chord members only. Additional temporary and permanent bracing is always required for stability and to prevent collapse with possible personal injury and property damage. For general guidance regarding the fabrication, storage, delivery, erection and bracing of trusses and truss systems, see

Safety Information available from Truss Plate Institute, 2670 Crain Highway, Suite 203 Waldorf, MD 20601

ANSI/TPI1 Quality Criteria, DSB-89 and BCSI Building Component



240 Stirling Crescent
 Bradford, ON. L3Z 4L5

Job	Truss	Truss Type	Qty	Ply	Buildings A-H	U1530855
N0653A	P2A	Scissor	38	1		

Alliance Truss (CA), Abbotsford, BC - V2S 7P6, 8.820 s Aug 30 2024 MiTek Industries, Inc. Thu Sep 12 02:48:15 2024 Page 1

ID:hFyjDMxrTsEK_kgkR0vWWWzFlgc-NRBMovAuthyCd61JdHeKs_u3ET5VUJXLZWN9syeVr_

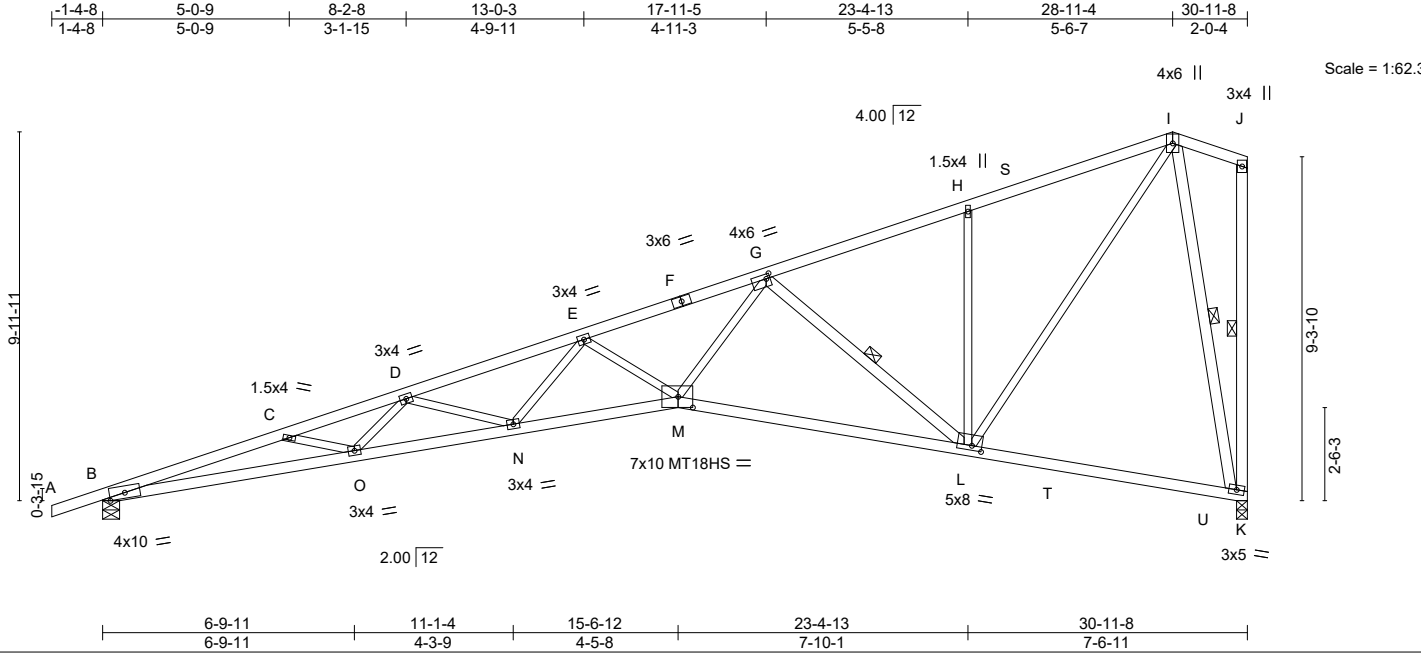

Plate Offsets (X,Y)-- [G:0-1-4,0-1-8], [L:0-3-4,0-1-8], [M:0-4-12,0-3-8]

LOADING (psf)	SPACING-	CSI.	DEFL.	PLATES	GRIP
TCLL 25.0 (Roof Snow=25.0)	2-0-0 Plate Grip DOL 1.15	TC 0.59	in (loc) l/defl L/d	MT20	197/144
TCDL 12.0	Lumber DOL 1.15	BC 0.83	Vert(LL) -0.54 N-O >683 360	MT18HS	197/144
BCLL 0.0 *	Rep Stress Incr YES	WB 0.84	Vert(CT) -0.98 N-O >376 240		
BCDL 10.0	Code IBC2018/TPI2014	Matrix-MS	Horz(CT) 0.45 K n/a n/a		
			Wind(LL) 0.31 N-O >999 240	Weight: 131 lb	FT = 20%

LUMBER-	BRACING-
TOP CHORD 2x4 SPF No.2 *Except* A-F: 2x4 SPF 2100F 1.8E	TOP CHORD Structural wood sheathing directly applied or 2-4-4 oc purlins, except end verticals.
BOT CHORD 2x4 SPF 2100F 1.8E	BOT CHORD Rigid ceiling directly applied or 8-3-6 oc bracing.
WEBS 2x3 SPF No.2 *Except* G-L,J-K,I-K: 2x4 SPF No.2	WEBS 1 Row at midpt G-L, J-K, I-K

REACTIONS. (size) B=0-5-8, K=0-3-8
 Max Horz B=300(LC 9)
 Max Uplift B=-205(LC 6), K=-185(LC 6)
 Max Grav B=1586(LC 3), K=1547(LC 3)

FORCES. (lb) - Max. Comp./Max. Ten. - All forces 250 (lb) or less except when shown.
 TOP CHORD B-C=-6709/822, C-D=-6571/758, D-E=-5757/677, E-G=-4567/538, G-H=-1496/191, H-I=-1515/253
 BOT CHORD B-O=-903/6397, N-O=-838/6187, M-N=-656/5068, L-M=-362/2974, K-L=-89/322
 WEBS D-N=-721/153, E-N=-55/729, E-M=-877/183, G-M=-259/2437, G-L=-2054/322, H-L=-479/152, I-L=-262/1982, I-K=-1478/168

- NOTES-**
- 1) Wind: ASCE 7-16; Vult=115mph (3-second gust) Vasd=91mph; TCDL=4.2psf; BCDL=5.0psf; h=30ft; Ke=1.00; Cat. II; Exp B; Enclosed; MWFRS (envelope) gable end zone; cantilever left and right exposed; end vertical left and right exposed; Lumber DOL=1.33 plate grip DOL=1.33
 - 2) TCLL: ASCE 7-16; Pf=25.0 psf (Lum DOL = 1.15 Plate DOL = 1.15); Is=1.0; Rough Cat B; Partially Exp.; Ce=1.0; Cs=1.00; Ct=1.10
 - 3) Unbalanced snow loads have been considered for this design.
 - 4) This truss has been designed for greater of min roof live load of 20.0 psf or 2.00 times flat roof load of 25.0 psf on overhangs non-concurrent with other live loads.
 - 5) All plates are MT20 plates unless otherwise indicated.
 - 6) This truss has been designed for a 10.0 psf bottom chord live load nonconcurrent with any other live loads.
 - 7) * This truss has been designed for a live load of 20.0psf on the bottom chord in all areas where a rectangle 3-6-0 tall by 2-0-0 wide will fit between the bottom chord and any other members, with BCDL = 10.0psf.
 - 8) Bearing at joint(s) B, K considers parallel to grain value using ANSI/TPI 1 angle to grain formula. Building designer should verify capacity of bearing surface.
 - 9) Provide mechanical connection (by others) of truss to bearing plate capable of withstanding 100 lb uplift at joint(s) except (jt=lb) B=205, K=185.
 - 10) This truss is designed in accordance with the 2018 International Building Code section 2306.1 and referenced standard ANSI/TPI 1.



September 12, 2024

WARNING - Verify design parameters and READ NOTES ON THIS AND INCLUDED MITEK REFERENCE PAGE MII-7473 rev. 6/30/2020 BEFORE USE.
 Design valid for use only with MiTek® connectors. This design is based only upon parameters shown, and is for an individual building component, not a truss system. Before use, the building designer must verify the applicability of design parameters and properly incorporate this design into the overall building design. Bracing indicated is to prevent buckling of individual truss web and/or chord members only. Additional temporary and permanent bracing is always required for stability and to prevent collapse with possible personal injury and property damage. For general guidance regarding the fabrication, storage, delivery, erection and bracing of trusses and truss systems, see **ANSI/TPI1 Quality Criteria, DSB-89 and BCSI Building Component Safety Information** available from Truss Plate Institute, 2670 Crain Highway, Suite 203 Waldorf, MD 20601



240 Stirling Crescent
Bradford, ON. L3Z 4L5

Job	Truss	Truss Type	Qty	Ply	Buildings A-H	U1530856
N0653A	P3A	Scissor	4	1		

Alliance Truss (CA), Abbotsford, BC - V2S 7P6, 8.820 s Aug 30 2024 MiTek Industries, Inc. Thu Sep 12 02:48:16 2024 Page 1
 ID:hFyjDMxrTsEK_kgkR0vWVWzFlgc-rdlk?FBWw?43FGcVB_9ZOCQC5tRJJDms0aDGLgJyeVqz

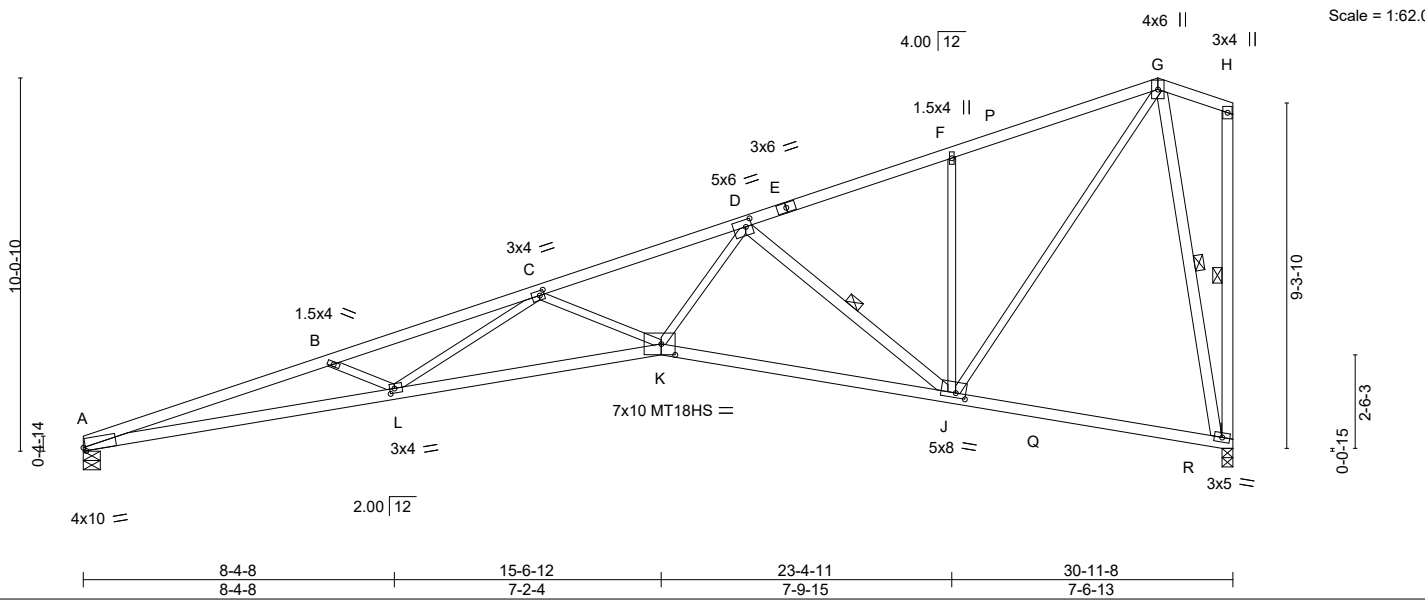

Plate Offsets (X,Y)-- [A:0-0-11,Edge], [C:0-1-8,0-1-8], [D:0-2-0,0-2-4], [J:0-3-4,0-1-8], [K:0-4-8,0-3-8], [L:0-1-8,0-1-8]

LOADING (psf)	SPACING-	CSI.	DEFL.	PLATES	GRIP
TCLL 25.0 (Roof Snow=25.0)	2-0-0 Plate Grip DOL 1.15	TC 0.72	in (loc) l/defl L/d	MT20	197/144
TCDL 12.0	Lumber DOL 1.15	BC 0.86	Vert(LL) -0.59 K-L >623 360	MT18HS	197/144
BCLL 0.0 *	Rep Stress Incr YES	WB 0.83	Vert(CT) -1.09 K-L >339 240		
BCDL 10.0	Code IBC2018/TPI2014	Matrix-MS	Horz(CT) 0.45 I n/a n/a		
			Wind(LL) 0.32 K-L >999 240	Weight: 127 lb	FT = 20%

LUMBER-	BRACING-
TOP CHORD 2x4 SPF No.2 *Except* A-E: 2x4 SPF 2100F 1.8E	TOP CHORD Structural wood sheathing directly applied or 2-3-2 oc purlins, except end verticals.
BOT CHORD 2x4 SPF 2100F 1.8E	BOT CHORD Rigid ceiling directly applied or 8-2-2 oc bracing.
WEBS 2x3 SPF No.2 *Except* D-J,H-I,G-I: 2x4 SPF No.2	WEBS 1 Row at midpt D-J, H-I, G-I

REACTIONS. (size) A=0-5-8, I=0-3-8
 Max Horz A=292(LC 9)
 Max Uplift A=-160(LC 6), I=-186(LC 6)
 Max Grav A=1499(LC 3), I=1549(LC 3)

FORCES. (lb) - Max. Comp./Max. Ten. - All forces 250 (lb) or less except when shown.
 TOP CHORD A-B=-6798/848, B-C=-6399/734, C-D=-4600/539, D-F=-1502/193, F-G=-1520/255
 BOT CHORD A-L=-921/6500, K-L=-713/5265, J-K=-372/3038, I-J=-89/322
 WEBS B-L=-487/180, C-L=-55/1066, C-K=-995/222, D-K=-249/2425, D-J=-2108/331,
 F-J=-480/151, G-J=-263/1985, G-I=-1478/168

- NOTES-**
- 1) Wind: ASCE 7-16; Vult=115mph (3-second gust) Vasd=91mph; TCDL=4.2psf; BCDL=5.0psf; h=30ft; Ke=1.00; Cat. II; Exp B; Enclosed; MWFRS (envelope) gable end zone; cantilever left and right exposed ; end vertical left and right exposed; Lumber DOL=1.33 plate grip DOL=1.33
 - 2) TCLL: ASCE 7-16; Pf=25.0 psf (Lum DOL = 1.15 Plate DOL = 1.15); Is=1.0; Rough Cat B; Partially Exp.; Ce=1.0; Cs=1.00; Ct=1.10
 - 3) Unbalanced snow loads have been considered for this design.
 - 4) All plates are MT20 plates unless otherwise indicated.
 - 5) This truss has been designed for a 10.0 psf bottom chord live load nonconcurrent with any other live loads.
 - 6) * This truss has been designed for a live load of 20.0psf on the bottom chord in all areas where a rectangle 3-6-0 tall by 2-0-0 wide will fit between the bottom chord and any other members, with BCDL = 10.0psf.
 - 7) Bearing at joint(s) I considers parallel to grain value using ANSI/TPI 1 angle to grain formula. Building designer should verify capacity of bearing surface.
 - 8) Provide mechanical connection (by others) of truss to bearing plate capable of withstanding 100 lb uplift at joint(s) except (jt=lb) A=160, I=186.
 - 9) Beveled plate or shim required to provide full bearing surface with truss chord at joint(s) A.
 - 10) This truss is designed in accordance with the 2018 International Building Code section 2306.1 and referenced standard ANSI/TPI 1.



September 12, 2024

WARNING - Verify design parameters and READ NOTES ON THIS AND INCLUDED MITEK REFERENCE PAGE MII-7473 rev. 6/30/2020 BEFORE USE.
 Design valid for use only with MiTek® connectors. This design is based only upon parameters shown, and is for an individual building component, not a truss system. Before use, the building designer must verify the applicability of design parameters and properly incorporate this design into the overall building design. Bracing indicated is to prevent buckling of individual truss web and/or chord members only. Additional temporary and permanent bracing is always required for stability and to prevent collapse with possible personal injury and property damage. For general guidance regarding the fabrication, storage, delivery, erection and bracing of trusses and truss systems, see **ANSI/TPI1 Quality Criteria, DSB-89 and BCSI Building Component Safety Information** available from Truss Plate Institute, 2670 Crain Highway, Suite 203 Waldorf, MD 20601



240 Stirling Crescent
 Bradford, ON. L3Z 4L5

Job	Truss	Truss Type	Qty	Ply	Buildings A-H	U1530788
N0653A	P4	Common	25	1		

Alliance Truss (CA), Abbotsford, BC - V2S 7P6, 8.630 s Jul 12 2024 MiTek Industries, Inc. Thu Sep 12 02:47:35 2024 Page 1

ID:hFyjDMxrTsEK_kgkR0vWWVzFfgc-RfC?PsB70Hq3NSgPqnL8w3ulTXbGKWrCDoi7J4zJC?f

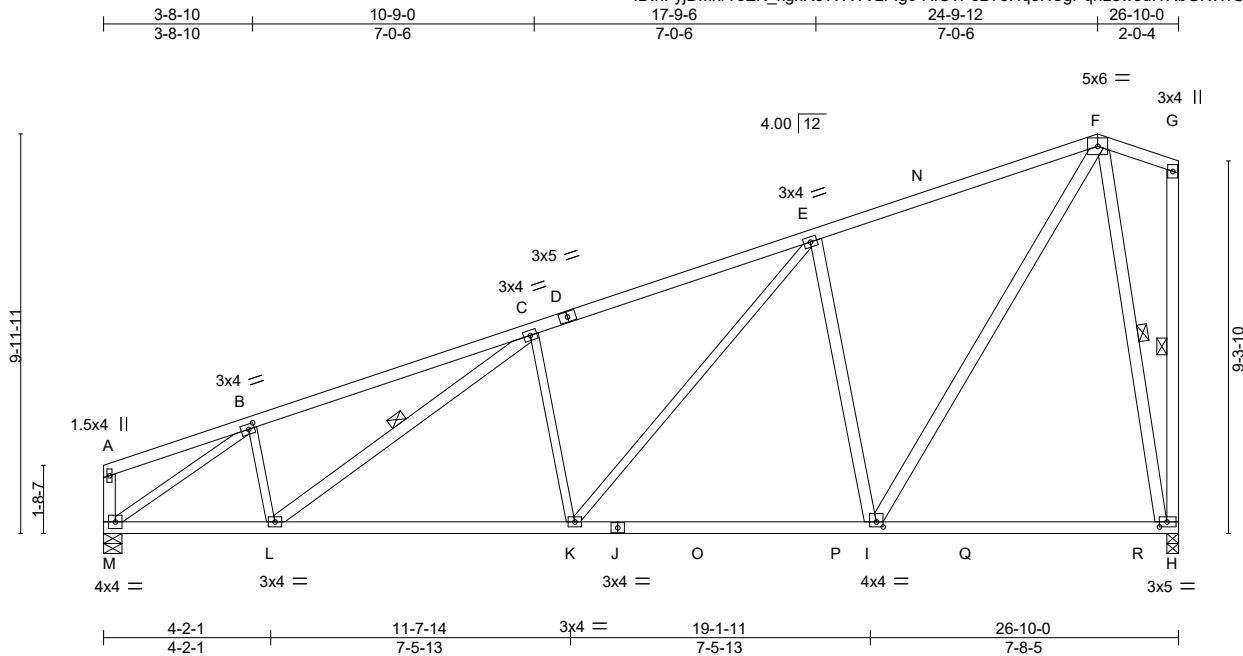

Plate Offsets (X,Y)-- [B:0-1-12,0-1-8], [H:0-2-4,0-1-8], [I:0-2-0,0-1-8]

LOADING (psf)	SPACING-	CSI.	DEFL.	in (loc)	l/defl	L/d	PLATES	GRIP
TCLL 25.0 (Roof Snow=25.0)	2-0-0 Plate Grip DOL 1.15 Lumber DOL 1.15	TC 0.72 BC 0.72 WB 0.97 Matrix-MS	Vert(LL) -0.16 Vert(CT) -0.26 Horz(CT) 0.05 Wind(LL) 0.06	H-I H-I H K-L	>999 >999 n/a >999	360 240 n/a 240	MT20	197/144
TCDL 12.0	Rep Stress Incr YES Code IBC2018/TPI2014						Weight: 132 lb	FT = 20%
BCLL 0.0 *								
BCDL 10.0								

LUMBER-

TOP CHORD 2x4 SPF No.2
 BOT CHORD 2x4 SPF No.2
 WEBS 2x4 SPF No.2 *Except*
 B-L,C-K,E-K,B-M: 2x3 SPF No.2

BRACING-

TOP CHORD Structural wood sheathing directly applied or 3-7-7 oc purlins, except end verticals.
 BOT CHORD Rigid ceiling directly applied or 10-0-0 oc bracing.
 WEBS 1 Row at midpt C-L, G-H, F-H

REACTIONS.

(size) M=0-5-8, H=0-3-8
 Max Horz M=285(LC 9)
 Max Uplift M=-134(LC 6), H=-162(LC 6)
 Max Grav M=1315(LC 3), H=1375(LC 3)

FORCES. (lb) - Max. Comp./Max. Ten. - All forces 250 (lb) or less except when shown.

TOP CHORD B-C=-1838/235, C-E=-1856/258, E-F=-1121/203
 BOT CHORD L-M=-260/1628, K-L=-227/1770, I-K=-132/1159, H-I=-84/251
 WEBS B-L=0/298, C-K=-472/178, E-K=-127/854, E-I=-983/250, F-I=-199/1456, B-M=-1974/205, F-H=-1277/165

NOTES-

- 1) Wind: ASCE 7-16; Vult=115mph (3-second gust) Vasd=91mph; TCDL=4.2psf; BCDL=5.0psf; h=30ft; Ke=1.00; Cat. II; Exp B; Enclosed; MWFRS (envelope) gable end zone; cantilever left and right exposed ; end vertical left and right exposed; Lumber DOL=1.33 plate grip DOL=1.33
- 2) TCLL: ASCE 7-16; Pf=25.0 psf (Lum DOL=1.15 Plate DOL=1.15); Is=1.0; Rough Cat B; Partially Exp.; Ce=1.0; Cs=1.00; Ct=1.10
- 3) Unbalanced snow loads have been considered for this design.
- 4) This truss has been designed for a 10.0 psf bottom chord live load nonconcurrent with any other live loads.
- 5) * This truss has been designed for a live load of 20.0psf on the bottom chord in all areas where a rectangle 3-6-0 tall by 2-0-0 wide will fit between the bottom chord and any other members, with BCDL = 10.0psf.
- 6) Provide mechanical connection (by others) of truss to bearing plate capable of withstanding 100 lb uplift at joint(s) except (jt=lb) M=134, H=162.
- 7) This truss is designed in accordance with the 2018 International Building Code section 2306.1 and referenced standard ANSI/TPI 1.



September 12, 2024

WARNING - Verify design parameters and READ NOTES ON THIS AND INCLUDED MITEK REFERENCE PAGE MII-7473 rev. 6/30/2020 BEFORE USE.

Design valid for use only with MiTek® connectors. This design is based only upon parameters shown, and is for an individual building component, not a truss system. Before use, the building designer must verify the applicability of design parameters and properly incorporate this design into the overall building design. Bracing indicated is to prevent buckling of individual truss web and/or chord members only. Additional temporary and permanent bracing is always required for stability and to prevent collapse with possible personal injury and property damage. For general guidance regarding the fabrication, storage, delivery, erection and bracing of trusses and truss systems, see

Safety Information available from Truss Plate Institute, 2670 Crain Highway, Suite 203 Waldorf, MD 20601



240 Stirling Crescent
 Bradford, ON. L3Z 4L5

Job	Truss	Truss Type	Qty	Ply	Buildings A-H	U1530789
N0653A	P5	GABLE	4	1		

Alliance Truss (CA), Abbotsford, BC - V2S 7P6, 8.630 s Jul 12 2024 MiTek Industries, Inc. Thu Sep 12 02:47:37 2024 Page 1

ID:hFyjDMxrTsEK_kgkR0vWWVzFfgc-RfC?PsB70Hq3NSgPqnL8w3ulTXbGKwRCDoi7J4zJC?f

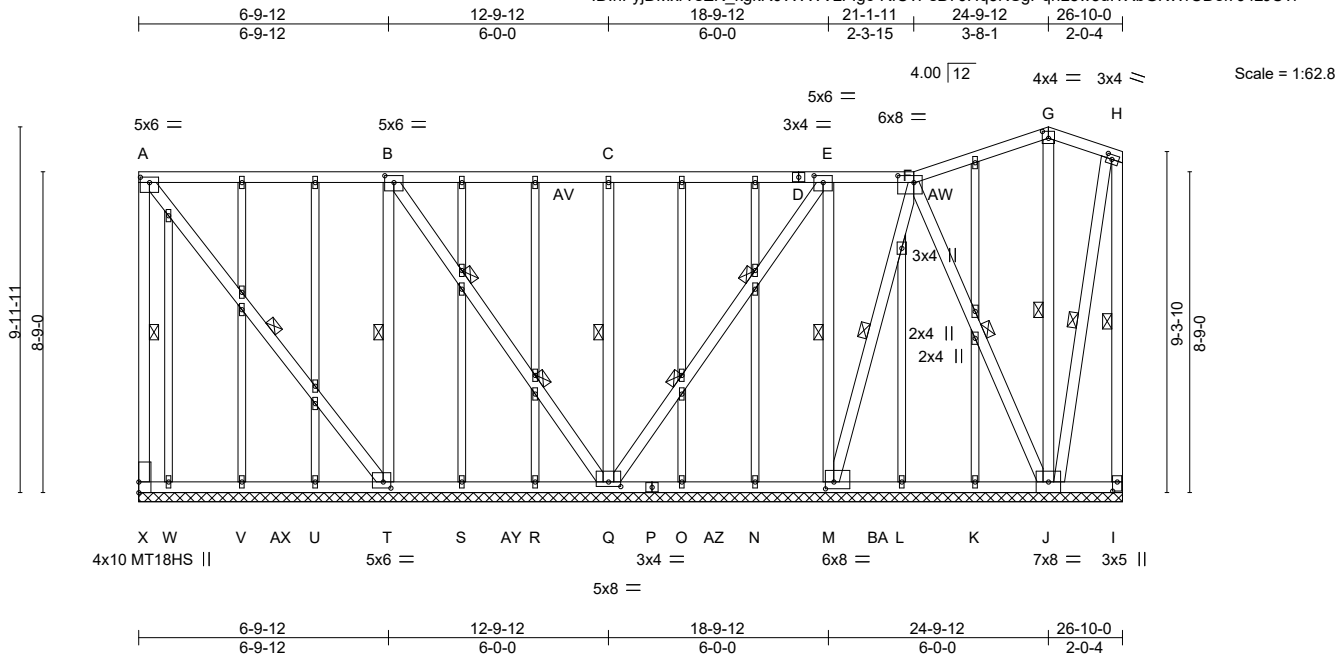

Plate Offsets (X,Y)-- [A:0-3-0,0-1-12], [B:0-3-0,0-2-4], [E:0-3-0,0-2-4], [F:0-5-4,0-2-4], [G:0-2-0,0-2-4], [H:0-1-12,0-1-8], [I:0-3-0,0-1-8], [M:0-2-12,0-2-4], [Q:0-4-0,0-1-8], [T:0-2-8,0-2-0]

LOADING (psf)	SPACING-	CSI.	DEFL.	PLATES	GRIP
TCLL 25.0 (Roof Snow=25.0)	2-0-0	TC 0.85	in (loc) l/defl L/d	MT20	197/144
TCDL 12.0	Plate Grip DOL 1.15	BC 0.33	Vert(LL) n/a - n/a 999	MT18HS	197/144
BCLL 0.0 *	Lumber DOL 1.15	WB 0.98	Vert(CT) n/a - n/a 999		
BCDL 10.0	Rep Stress Incr YES	Matrix-S	Horz(CT) -0.01 Q n/a n/a		
	Code IBC2018/TPI2014			Weight: 242 lb	FT = 20%

LUMBER-
 TOP CHORD 2x4 SPF No.2
 BOT CHORD 2x4 SPF No.2
 WEBS 2x4 SPF No.2 *Except*
 A-X,A-T: 2x4 SPF 2100F 1.8E
 OTHERS 2x3 SPF No.2

BRACING-
 TOP CHORD Structural wood sheathing directly applied or 4-1-14 oc purlins, except end verticals.
 BOT CHORD Rigid ceiling directly applied or 4-7-5 oc bracing.
 WEBS 1 Row at midpt A-X, A-T, B-T, C-Q, E-M, F-M, F-J, G-J, H-I, H-J
 2 Rows at 1/3 pts B-Q, E-Q

REACTIONS. All bearings 26-10-0.
 (lb) - Max Horz X=-159(LC 37)
 Max Uplift All uplift 100 lb or less at joint(s) except X=-2533(LC 36), T=-542(LC 41), Q=-227(LC 40), M=-774(LC 32), J=-1684(LC 33), I=-853(LC 35), W=-126(LC 35)
 Max Grav All reactions 250 lb or less at joint(s) K, L, N, O, R, S, U, V, W except X=2473(LC 35), T=751(LC 28), Q=1118(LC 68), M=899(LC 29), J=1770(LC 52), I=871(LC 52)

FORCES. (lb) - Max. Comp./Max. Ten. - All forces 250 (lb) or less except when shown.
 TOP CHORD A-X=-2388/2402, A-B=-1877/1861, B-C=-1612/1590, C-E=-1375/1353, E-F=-541/522, F-G=-1250/1223, G-H=-294/311, H-I=-848/853
 BOT CHORD V-W=708/702, U-V=-1188/1182, T-U=-1668/1662, S-T=-282/274, R-S=-762/754, Q-R=-1242/1234, O-Q=-1493/1488, N-O=-1013/1008, M-N=-533/528, L-M=-766/763, K-L=-286/283, J-K=-696/693, I-J=-448/448
 WEBS A-T=-3019/3015, B-T=-1990/1993, B-Q=-2347/2335, C-Q=-658/135, E-Q=-2411/2408, E-M=-1962/1955, F-M=-2717/2714, F-J=-2461/2468, G-J=-329/236, H-J=-798/798

- NOTES-**
- 1) Wind: ASCE 7-16; Vult=115mph (3-second gust) Vasd=91mph; TCDL=4.2psf; BCDL=5.0psf; h=30ft; Ke=1.00; Cat. II; Exp B; Enclosed; MWFRS (envelope) gable end zone; cantilever left exposed; end vertical left exposed; Lumber DOL=1.33 plate grip DOL=1.33
 - 2) Truss designed for wind loads in the plane of the truss only. For studs exposed to wind (normal to the face), see Standard Industry Gable End Details as applicable, or consult qualified building designer as per ANSI/TPI 1.
 - 3) TCLL: ASCE 7-16; Pf=25.0 psf (Lum DOL=1.15 Plate DOL=1.15); Is=1.0; Rough Cat B; Partially Exp.; Ce=1.0; Cs=1.00; Ct=1.10
 - 4) Unbalanced snow loads have been considered for this design.
 - 5) Provide adequate drainage to prevent water ponding.
 - 6) All plates are MT20 plates unless otherwise indicated.
 - 7) All plates are 1.5x4 MT20 unless otherwise indicated.
 - 8) Gable requires continuous bottom chord bearing.
 - 9) Gable studs spaced at 2-0-0 oc.
 - 10) This truss has been designed for a 10.0 psf bottom chord live load nonconcurrent with any other live loads.
 - 11) * This truss has been designed for a live load of 20.0psf on the bottom chord in all areas where a rectangle 3-6-0 tall by 2-0-0 wide will fit between the bottom chord and any other members, with BCDL = 10.0psf.



September 12, 2024

Continued on page 2

WARNING - Verify design parameters and READ NOTES ON THIS AND INCLUDED MITEK REFERENCE PAGE MII-7473 rev. 6/30/2020 BEFORE USE.

Design valid for use only with MiTek® connectors. This design is based only upon parameters shown, and is for an individual building component, not a truss system. Before use, the building designer must verify the applicability of design parameters and properly incorporate this design into the overall building design. Bracing indicated is to prevent buckling of individual truss web and/or chord members only. Additional temporary and permanent bracing is always required for stability and to prevent collapse with possible personal injury and property damage. For general guidance regarding the fabrication, storage, delivery, erection and bracing of trusses and truss systems, see

ANSI/TPI1 Quality Criteria, DSB-89 and BCSI Building Component Safety Information available from Truss Plate Institute, 2670 Crain Highway, Suite 203 Waldorf, MD 20601



240 Stirling Crescent
 Bradford, ON. L3Z 4L5

Job	Truss	Truss Type	Qty	Ply	Buildings A-H
N0653A	P5	GABLE	4	1	U1530789

Alliance Truss (CA), Abbotsford, BC - V2S 7P6,

8.630 s Jul 12 2024 MiTek Industries, Inc. Thu Sep 12 02:47:37 2024 Page 2
ID:hFyjDMxrTsEK_kgkR0vWWVzFigc-RfC?PsB70Hq3NSgPqnL8w3ulTXbGKWrCDoi7J4zJC?f**NOTES-**

- 12) Provide mechanical connection (by others) of truss to bearing plate capable of withstanding 2533 lb uplift at joint X, 542 lb uplift at joint T, 227 lb uplift at joint Q, 774 lb uplift at joint M, 1684 lb uplift at joint J, 853 lb uplift at joint I and 126 lb uplift at joint W.
- 13) This truss is designed in accordance with the 2018 International Building Code section 2306.1 and referenced standard ANSI/TPI 1.
- 14) This truss has been designed for a total drag load of 240 plf. Lumber DOL=(1.33) Plate grip DOL=(1.33) Connect truss to resist drag loads along bottom chord from 0-0-0 to 26-10-0 for 240.0 plf.

WARNING - Verify design parameters and READ NOTES ON THIS AND INCLUDED MITEK REFERENCE PAGE MII-7473 rev. 6/30/2020 BEFORE USE.

Design valid for use only with MiTek® connectors. This design is based only upon parameters shown, and is for an individual building component, not a truss system. Before use, the building designer must verify the applicability of design parameters and properly incorporate this design into the overall building design. Bracing indicated is to prevent buckling of individual truss web and/or chord members only. Additional temporary and permanent bracing is always required for stability and to prevent collapse with possible personal injury and property damage. For general guidance regarding the fabrication, storage, delivery, erection and bracing of trusses and truss systems, see

Safety Information available from Truss Plate Institute, 2670 Crain Highway, Suite 203 Waldorf, MD 20601

ANSI/TPI1 Quality Criteria, DSB-89 and BCSI Building Component



240 Stirling Crescent
Bradford, ON. L3Z 4L5

Job N0653A	Truss P6	Truss Type GABLE	Qty 4	Ply 1	Buildings A-H U1530790
---------------	-------------	---------------------	----------	----------	---------------------------

Alliance Truss (CA), Abbotsford, BC - V2S 7P6, 8.630 s Jul 12 2024 MiTek Industries, Inc. Thu Sep 12 02:47:38 2024 Page 1

ID:hFyjDMxrTsEK_kgkR0vWWVzFlgc-RfC?PsB70Hg3NSgPqnL8w3ulTXbGKWrCDoi7J4zJC?f

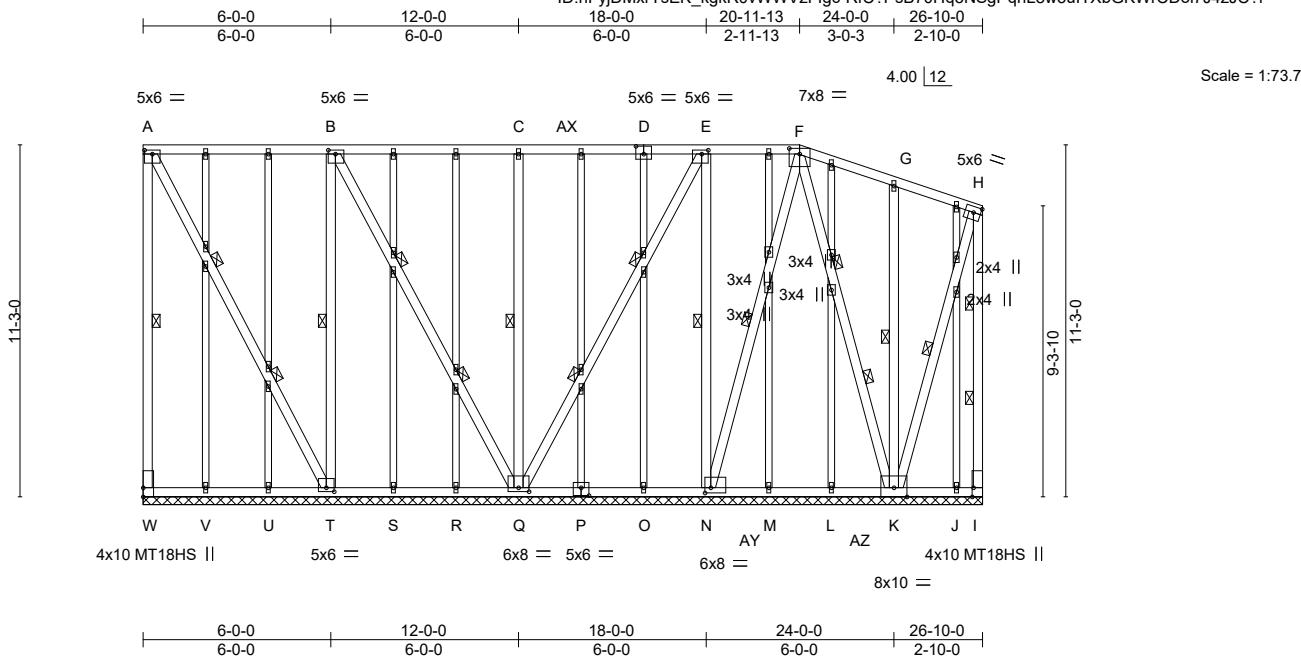

Plate Offsets (X,Y)-- [A:0-3-0,0-1-8], [B:0-2-12,0-1-8], [D:0-3-0,0-3-0], [E:0-2-8,0-1-8], [F:0-4-0,0-2-3], [H:0-2-12,0-2-4], [I:0-3-8,Edge], [N:0-2-4,0-2-0], [P:0-3-0,0-3-0], [Q:0-4-0,0-1-8], [T:0-3-0,0-1-8]

LOADING (psf)	SPACING-	CSI.	DEFL.	PLATES	GRIP
TCLL 25.0 (Roof Snow=25.0)	2-0-0	TC 0.88	in (loc) l/defl L/d	MT20	197/144
TCDL 12.0	Plate Grip DOL 1.15	BC 0.33	Vert(LL) n/a - n/a 999	MT18HS	197/144
BCLL 0.0 *	Lumber DOL 1.15	WB 1.00	Vert(CT) n/a - n/a 999		
BCDL 10.0	Rep Stress Incr YES	Matrix-S	Horz(CT) 0.02 Q n/a n/a		
	Code IBC2018/TPI2014			Weight: 283 lb	FT = 20%

LUMBER-	BRACING-
TOP CHORD 2x4 SPF No.2	TOP CHORD Structural wood sheathing directly applied or 4-9-5 oc purlins, except end verticals.
BOT CHORD 2x4 SPF No.2	BOT CHORD Rigid ceiling directly applied or 4-8-5 oc bracing.
WEBS 2x4 SPF 2100F 1.8E *Except* G-K,H-I,H-K: 2x4 SPF No.2	WEBS 1 Row at midpt A-W, B-T, C-Q, E-N, F-N, G-K, H-K 2 Rows at 1/3 pts A-T, B-Q, E-Q, F-K, H-I
OTHERS 2x3 SPF No.2	

REACTIONS. All bearings 26-10-0.
 (lb) - Max Horz W=-184(LC 33)
 Max Uplift All uplift 100 lb or less at joint(s) except W=-2704(LC 32), T=-119(LC 34), Q=-208(LC 33), N=-332(LC 34), I=-1801(LC 39), K=-1788(LC 35), J=-138(LC 32)
 Max Grav All reactions 250 lb or less at joint(s) V, U, S, R, O, M, L, J except W=2688(LC 51), T=578(LC 64), Q=1224(LC 64), N=535(LC 29), I=1782(LC 32), K=1844(LC 52)

FORCES. (lb) - Max. Comp./Max. Ten. - All forces 250 (lb) or less except when shown.
 TOP CHORD A-W=-2661/2699, A-B=-1408/1416, B-C=-1456/1464, C-E=-1487/1495, E-F=-771/805, F-G=-977/1027, G-H=-568/541, H-I=-1670/1650
 BOT CHORD V-W=-592/625, U-V=-1072/1105, T-U=-1552/1585, S-T=-627/653, R-S=-1107/1133, Q-R=-1587/1613, O-Q=-1534/1535, N-O=-574/575, M-N=-872/862, L-M=-392/382, K-L=-786/775, J-K=-740/716, I-J=-260/236
 WEBS A-T=-2996/2982, B-T=-2730/2757, B-Q=-3055/3048, C-Q=-676/137, E-Q=-3062/3111, E-N=-2681/2674, F-N=-2987/3003, F-K=-3332/3303, G-K=-377/112, H-K=-1597/1615

- NOTES-**
- 1) Wind: ASCE 7-16; Vult=115mph (3-second gust) Vasd=91mph; TCDL=4.2psf; BCDL=5.0psf; h=30ft; Ke=1.00; Cat. II; Exp B; Enclosed; MWFRS (envelope) gable end zone; cantilever right exposed; end vertical right exposed; Lumber DOL=1.33 plate grip DOL=1.33
 - 2) Truss designed for wind loads in the plane of the truss only. For studs exposed to wind (normal to the face), see Standard Industry Gable End Details as applicable, or consult qualified building designer as per ANSI/TPI 1.
 - 3) TCLL: ASCE 7-16; Pf=25.0 psf (Lum DOL=1.15 Plate DOL=1.15); Is=1.0; Rough Cat B; Partially Exp.; Ce=1.0; Cs=1.00; Ct=1.10
 - 4) Unbalanced snow loads have been considered for this design.
 - 5) Provide adequate drainage to prevent water ponding.
 - 6) All plates are MT20 plates unless otherwise indicated.
 - 7) All plates are 1.5x4 MT20 unless otherwise indicated.
 - 8) Gable requires continuous bottom chord bearing.
 - 9) Gable studs spaced at 2-0-0 oc.
 - 10) This truss has been designed for a 10.0 psf bottom chord live load nonconcurrent with any other live loads.
 - 11) * This truss has been designed for a live load of 20.0psf on the bottom chord in all areas where a rectangle 3-6-0 tall by 2-0-0 wide will fit between the bottom chord and any other members, with BCDL = 10.0psf.



September 12, 2024

Continued on page 2

WARNING - Verify design parameters and READ NOTES ON THIS AND INCLUDED MITEK REFERENCE PAGE MII-7473 rev. 6/30/2020 BEFORE USE.

Design valid for use only with MiTek® connectors. This design is based only upon parameters shown, and is for an individual building component, not a truss system. Before use, the building designer must verify the applicability of design parameters and properly incorporate this design into the overall building design. Bracing indicated is to prevent buckling of individual truss web and/or chord members only. Additional temporary and permanent bracing is always required for stability and to prevent collapse with possible personal injury and property damage. For general guidance regarding the fabrication, storage, delivery, erection and bracing of trusses and truss systems, see

ANSI/TPI1 Quality Criteria, DSB-89 and BCSI Building Component Safety Information available from Truss Plate Institute, 2670 Crain Highway, Suite 203 Waldorf, MD 20601



240 Stirling Crescent
Bradford, ON. L3Z 4L5

Job	Truss	Truss Type	Qty	Ply	Buildings A-H
N0653A	P6	GABLE	4	1	U1530790

Alliance Truss (CA), Abbotsford, BC - V2S 7P6,

8.630 s Jul 12 2024 MiTek Industries, Inc. Thu Sep 12 02:47:39 2024 Page 2
ID:hFyjDMxrTsEK_kgkR0vWWVzFigc-RfC?PsB70Hq3NSgPqnL8w3ulTXbGKWrCDoi7J4zJC?f**NOTES-**

- 12) Provide mechanical connection (by others) of truss to bearing plate capable of withstanding 2704 lb uplift at joint W, 119 lb uplift at joint T, 208 lb uplift at joint Q, 332 lb uplift at joint N, 1801 lb uplift at joint I, 1788 lb uplift at joint K and 138 lb uplift at joint J.
- 13) This truss is designed in accordance with the 2018 International Building Code section 2306.1 and referenced standard ANSI/TPI 1.
- 14) This truss has been designed for a total drag load of 240 plf. Lumber DOL=(1.33) Plate grip DOL=(1.33) Connect truss to resist drag loads along bottom chord from 0-0-0 to 26-10-0 for 240.0 plf.

WARNING - Verify design parameters and READ NOTES ON THIS AND INCLUDED MITEK REFERENCE PAGE MII-7473 rev. 6/30/2020 BEFORE USE.

Design valid for use only with MiTek® connectors. This design is based only upon parameters shown, and is for an individual building component, not a truss system. Before use, the building designer must verify the applicability of design parameters and properly incorporate this design into the overall building design. Bracing indicated is to prevent buckling of individual truss web and/or chord members only. Additional temporary and permanent bracing is always required for stability and to prevent collapse with possible personal injury and property damage. For general guidance regarding the fabrication, storage, delivery, erection and bracing of trusses and truss systems, see

Safety Information available from Truss Plate Institute, 2670 Crain Highway, Suite 203 Waldorf, MD 20601

ANSI/TPI1 Quality Criteria, DSB-89 and BCSI Building Component



240 Stirling Crescent
Bradford, ON. L3Z 4L5

Job	Truss	Truss Type	Qty	Ply	Buildings A-H	U1530791
N0653A	P7	Common	24	1		

Alliance Truss (CA), Abbotsford, BC - V2S 7P6, 8.630 s Jul 12 2024 MiTek Industries, Inc. Thu Sep 12 02:47:39 2024 Page 1

ID:hFyjDMxrTsEK_kgkR0vWWVzFfgc-RfC?PsB70Hq3NSgPqnL8w3ulTXbGKWrCDoi7J4zJC?f

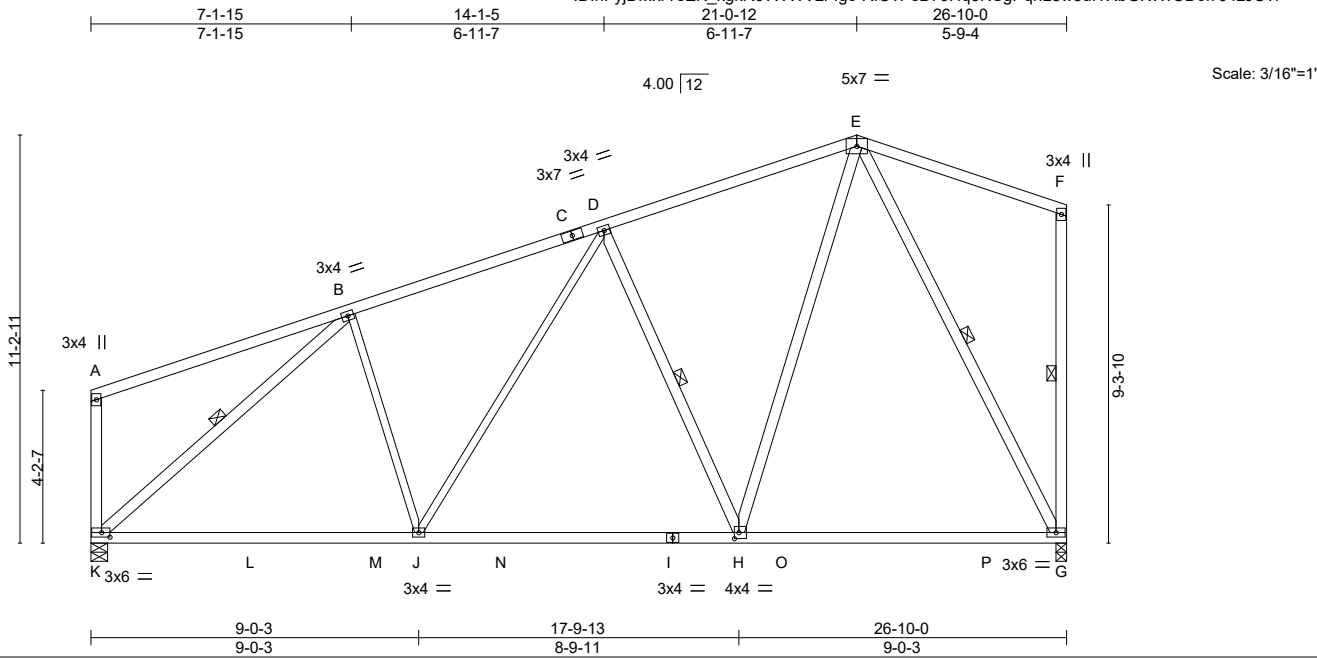

Plate Offsets (X,Y)-- [H:0-1-8,0-2-0], [K:0-2-12,0-1-8]

LOADING (psf)	SPACING-	CSI.	DEFL.	PLATES	GRIP
TCLL 25.0 (Roof Snow=25.0)	2-0-0 Plate Grip DOL 1.15 Lumber DOL 1.15 Rep Stress Incr YES Code IBC2018/TPI2014	TC 0.83 BC 0.90 WB 0.86 Matrix-MS	in (loc) l/defl L/d Vert(LL) -0.31 G-H >999 360 Vert(CT) -0.49 G-H >652 240 Horz(CT) 0.04 G n/a n/a Wind(LL) -0.05 G-H >999 240	MT20	197/144
TCDL 12.0				Weight: 137 lb	FT = 20%
BCLL 0.0 *					
BCDL 10.0					

LUMBER-

TOP CHORD 2x4 SPF No.2
 BOT CHORD 2x4 SPF No.2
 WEBS 2x4 SPF No.2 *Except*
 B-J,D-J: 2x3 SPF No.2

BRACING-

TOP CHORD Structural wood sheathing directly applied or 2-2-0 oc purlins, except end verticals.
 BOT CHORD Rigid ceiling directly applied or 10-0-0 oc bracing.
 WEBS 1 Row at midpt D-H, B-K, F-G, E-G

REACTIONS.

(size) K=0-5-8, G=0-3-8
 Max Horz K=262(LC 7)
 Max Uplift K=-135(LC 6), G=-125(LC 6)
 Max Grav K=1410(LC 3), G=1397(LC 2)

FORCES. (lb) - Max. Comp./Max. Ten. - All forces 250 (lb) or less except when shown.

TOP CHORD B-D=-1415/184, D-E=-1053/174, F-G=-293/68
 BOT CHORD J-K=-204/1220, H-J=-159/1168, G-H=-114/592
 WEBS B-J=0/257, D-J=-23/265, D-H=-724/193, E-H=-93/1090, B-K=-1567/155, E-G=-1263/128

NOTES-

- 1) Wind: ASCE 7-16; Vult=115mph (3-second gust) Vasd=91mph; TCDL=4.2psf; BCDL=5.0psf; h=30ft; Ke=1.00; Cat. II; Exp B; Enclosed; MWFRS (envelope) gable end zone; cantilever left and right exposed; end vertical left and right exposed; Lumber DOL=1.33 plate grip DOL=1.33
- 2) TCLL: ASCE 7-16; Pf=25.0 psf (Lum DOL=1.15 Plate DOL=1.15); Is=1.0; Rough Cat B; Partially Exp.; Ce=1.0; Cs=1.0; Ct=1.10
- 3) Unbalanced snow loads have been considered for this design.
- 4) This truss has been designed for a 10.0 psf bottom chord live load nonconcurrent with any other live loads.
- 5) * This truss has been designed for a live load of 20.0psf on the bottom chord in all areas where a rectangle 3-6-0 tall by 2-0-0 wide will fit between the bottom chord and any other members, with BCDL = 10.0psf.
- 6) Provide mechanical connection (by others) of truss to bearing plate capable of withstanding 135 lb uplift at joint K and 125 lb uplift at joint G.
- 7) This truss is designed in accordance with the 2018 International Building Code section 2306.1 and referenced standard ANSI/TPI 1.



September 12, 2024

WARNING - Verify design parameters and READ NOTES ON THIS AND INCLUDED MITEK REFERENCE PAGE MII-7473 rev. 6/30/2020 BEFORE USE.

Design valid for use only with MiTek® connectors. This design is based only upon parameters shown, and is for an individual building component, not a truss system. Before use, the building designer must verify the applicability of design parameters and properly incorporate this design into the overall building design. Bracing indicated is to prevent buckling of individual truss web and/or chord members only. Additional temporary and permanent bracing is always required for stability and to prevent collapse with possible personal injury and property damage. For general guidance regarding the fabrication, storage, delivery, erection and bracing of trusses and truss systems, see **ANSI/TPI1 Quality Criteria, DSB-89 and BCSI Building Component Safety Information** available from Truss Plate Institute, 2670 Crain Highway, Suite 203 Waldorf, MD 20601



240 Stirling Crescent
 Bradford, ON. L3Z 4L5

Job N0653A	Truss P8A	Truss Type GABLE	Qty 3	Ply 1	Buildings A-H Job Reference (optional)	U1530857
---------------	--------------	---------------------	----------	----------	---	----------

Alliance Truss (CA), Abbotsford, BC - V2S 7P6, 8.820 s Aug 30 2024 MiTek Industries, Inc. Thu Sep 12 02:48:17 2024 Page 1

ID:hFyjDMxrTsEK_kgkR0vWWVzFfgc-JqJ6DaC8PJcwsQBhkigoxPzNtHlyzBV9pt?uClIyeVqy

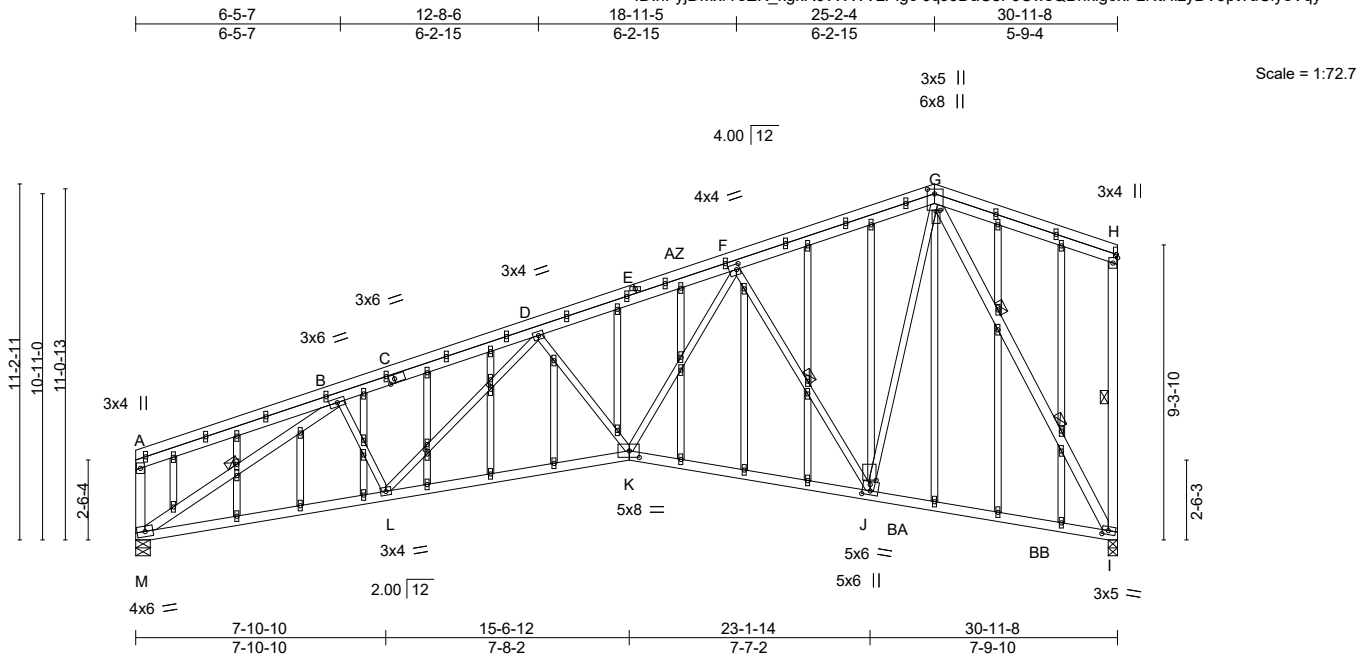

Plate Offsets (X,Y)-- [C:0-2-0,0-1-8], [F:0-1-4,0-2-0], [G:0-0-8,0-1-8], [G:0-1-12,0-2-12], [H:Edge,0-0-8], [I:0-2-4,0-1-8], [J:0-1-10,0-2-4], [J:0-3-0,0-1-8], [K:0-3-12,0-2-8], [AB:0-1-9,0-0-12], [AE:0-1-9,0-0-12]

LOADING (psf)	SPACING-	CSI.	DEFL.	in (loc)	l/defl	L/d	PLATES	GRIP
TCLL 25.0 (Roof Snow=25.0)	2-0-0 Plate Grip DOL 1.15 Lumber DOL 1.15	TC 0.71 BC 0.96	Vert(LL) -0.23 Vert(CT) -0.44 Horz(CT) 0.20 Wind(LL) 0.10	K-L K-L I K-L	>999 >839 n/a >999	360 240 n/a 240	MT20	197/144
TCDL 12.0	Rep Stress Incr YES	WB 1.00						
BCLL 0.0 *	Code IBC2018/TPI2014	Matrix-MS					Weight: 239 lb	FT = 20%
BCDL 10.0								

LUMBER-
 TOP CHORD 2x4 SPF No.2
 BOT CHORD 2x4 SPF No.2
 WEBS 2x3 SPF No.2 *Except*
 A-M,B-M,H-I,G-I: 2x4 SPF No.2
 OTHERS 2x3 SPF No.2

BRACING-
 TOP CHORD Structural wood sheathing directly applied or 2-11-15 oc purlins, except end verticals.
 BOT CHORD Rigid ceiling directly applied or 10-0-0 oc bracing, Except:
 2-2-0 oc bracing: K-L.
 WEBS 1 Row at midpt F-J, B-M, H-I
 2 Rows at 1/3 pts G-I

REACTIONS. (size) M=0-5-8, I=0-3-8
 Max Horz M=260(LC 7)
 Max Uplift M=-157(LC 6), I=-152(LC 6)
 Max Grav M=1524(LC 3), I=1538(LC 2)

FORCES. (lb) - Max. Comp./Max. Ten. - All forces 250 (lb) or less except when shown.
 TOP CHORD B-D=-2704/322, D-F=-2643/324, F-G=-1220/187, H-I=-306/68
 BOT CHORD L-M=-337/2345, K-L=-323/2679, J-K=-210/1847, I-J=-124/804
 WEBS B-L=0/434, D-K=-356/139, F-K=-139/1352, F-J=-1497/264, G-J=-122/1453,
 B-M=-2724/306, G-I=-1605/138

- NOTES-**
- 1) Wind: ASCE 7-16; Vult=115mph (3-second gust) Vasd=91mph; TCDL=4.2psf; BCDL=5.0psf; h=30ft; Ke=1.00; Cat. II; Exp B; Enclosed; MWFRS (envelope) gable end zone; cantilever left and right exposed; end vertical left and right exposed; Lumber DOL=1.33 plate grip DOL=1.33
 - 2) Truss designed for wind loads in the plane of the truss only. For studs exposed to wind (normal to the face), see Standard Industry Gable End Details as applicable, or consult qualified building designer as per ANSI/TPI 1.
 - 3) TCLL: ASCE 7-16; Pf=25.0 psf (Lum DOL = 1.15 Plate DOL = 1.15); Is=1.0; Rough Cat B; Partially Exp.; Ce=1.0; Cs=1.00; Ct=1.10
 - 4) Unbalanced snow loads have been considered for this design.
 - 5) All plates are 1.5x4 MT20 unless otherwise indicated.
 - 6) Gable studs spaced at 2-0-0 oc.
 - 7) This truss has been designed for a 10.0 psf bottom chord live load nonconcurrent with any other live loads.
 - 8) * This truss has been designed for a live load of 20.0psf on the bottom chord in all areas where a rectangle 3-6-0 tall by 2-0-0 wide will fit between the bottom chord and any other members, with BCDL = 10.0psf.
 - 9) Bearing at joint(s) M, I considers parallel to grain value using ANSI/TPI 1 angle to grain formula. Building designer should verify capacity of bearing surface.
 - 10) Provide mechanical connection (by others) of truss to bearing plate capable of withstanding 100 lb uplift at joint(s) except (jt=lb) M=157, I=152.
 - 11) This truss is designed in accordance with the 2018 International Building Code section 2306.1 and referenced standard ANSI/TPI 1.
 - 12) No notches allowed in overhang and 0 from left end and 0 from right end or 12" along rake from scarf, whichever is larger. Minimum 1.5x4 tie plates required at 2-0-0 o.c. maximum between the stacking chords. For edge-wise notching, provide at least one tie plate between each notch.



September 12, 2024

WARNING - Verify design parameters and READ NOTES ON THIS AND INCLUDED MITEK REFERENCE PAGE MII-7473 rev. 6/30/2020 BEFORE USE.
 Design valid for use only with MiTek® connectors. This design is based only upon parameters shown, and is for an individual building component, not a truss system. Before use, the building designer must verify the applicability of design parameters and properly incorporate this design into the overall building design. Bracing indicated is to prevent buckling of individual truss web and/or chord members only. Additional temporary and permanent bracing is always required for stability and to prevent collapse with possible personal injury and property damage. For general guidance regarding the fabrication, storage, delivery, erection and bracing of trusses and truss systems, see **ANSI/TPI1 Quality Criteria, DSB-89 and BCSI Building Component Safety Information** available from Truss Plate Institute, 2670 Crain Highway, Suite 203 Waldorf, MD 20601



Job N0653A	Truss P9	Truss Type GABLE	Qty 1	Ply 1	Buildings A-H U1530792
---------------	-------------	---------------------	----------	----------	---------------------------

Alliance Truss (CA), Abbotsford, BC - V2S 7P6, 8.630 s Feb 9 2023 MiTek Industries, Inc. Thu Sep 12 16:09:48 2024 Page 1
 ID:hFyJDMxrTsEK_kgkR0vWVvzFfgc-SFyMHHkZ5_a2tBB8VwsRq1Cxt2MQFD4VKICNmyeUeX

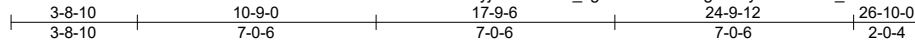

Scale = 1:67.9

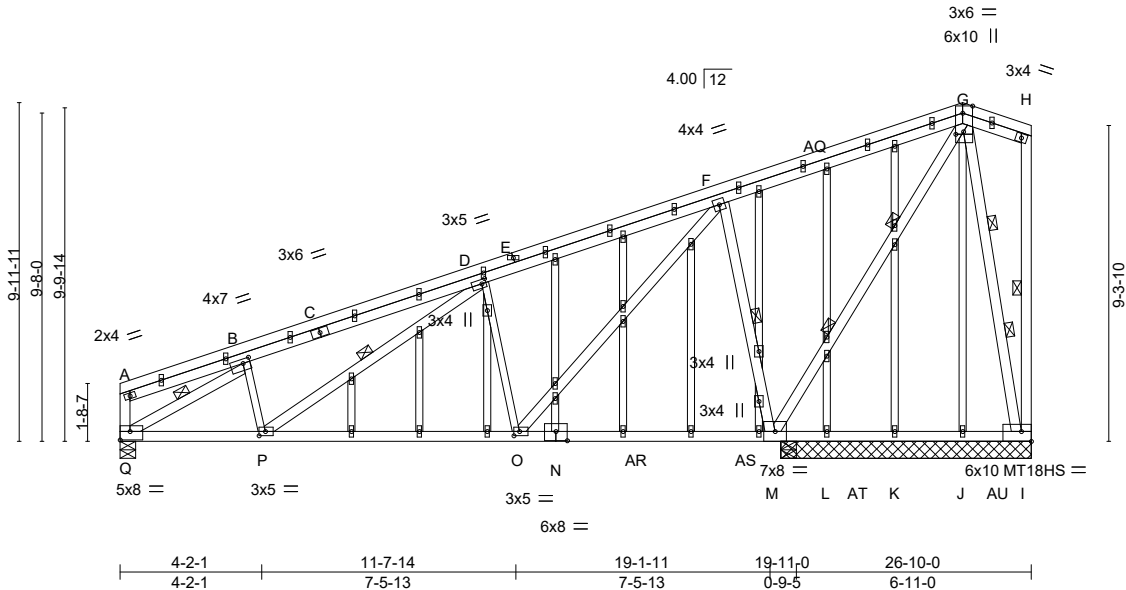

Plate Offsets (X,Y)-- [B:0-2-8,0-1-8], [D:0-1-8,0-1-8], [G:0-2-12,0-0-14], [I:0-2-8,Edge], [L:Edge,0-3-8], [N:0-4-0,0-3-4], [O:0-2-0,0-1-8], [P:0-2-4,0-1-8], [Q:Edge,0-3-0]

LOADING (psf)	SPACING-	CSI.	DEFL.	PLATES	GRIP
TCLL 25.0 (Roof Snow=25.0)	2-0-0 Plate Grip DOL 1.15 Lumber DOL 1.15 Rep Stress Incr YES Code IBC2018/TPI2014	TC 0.82 BC 0.95 WB 0.94 Matrix-MS	in (loc) l/defl L/d Vert(LL) -0.14 O-P >999 360 Vert(CT) -0.22 O-P >999 240 Horz(CT) -0.14 I n/a n/a Wind(LL) 0.12 O-P >999 240	MT20 MT18HS Weight: 211 lb	197/144 197/144 FT = 20%

LUMBER-	BRACING-
TOP CHORD 2x4 SPF No.2	TOP CHORD Structural wood sheathing directly applied or 3-4-5 oc purlins, except end verticals.
BOT CHORD 2x4 SPF 2100F 1.8E *Except* N-Q: 2x4 SPF No.2	BOT CHORD Rigid ceiling directly applied or 2-2-0 oc bracing.
WEBS 2x4 SPF No.2 *Except* B-P,D-O: 2x3 SPF No.2, G-M: 2x4 SPF 2100F 1.8E	WEBS 1 Row at midpt D-P, F-M, B-Q, H-I 2 Rows at 1/3 pts G-M, G-I
OTHERS 2x3 SPF No.2	

REACTIONS. All bearings 7-4-8 except (jt=length) Q=0-5-8.
 (lb) - Max Horz Q=471(LC 37)
 Max Uplift All uplift 100 lb or less at joint(s) J except M=-3032(LC 39), Q=-1657(LC 31), I=-2686(LC 50), L=-118(LC 26)
 Max Grav All reactions 250 lb or less at joint(s) J, K, L except M=4048(LC 28), M=1815(LC 1), Q=1949(LC 26), I=2571(LC 39)

FORCES. (lb) - Max. Comp./Max. Ten. - All forces 250 (lb) or less except when shown.
 TOP CHORD A-B=-803/824, B-D=-2462/1943, D-F=-1581/1341, F-G=-2032/2184, G-H=-521/548
 BOT CHORD P-Q=-2786/3032, O-P=-3904/4061, M-O=-4358/4252, L-M=-6183/6132, K-L=-4694/4698, J-K=-3002/2951, I-J=-1256/1205
 WEBS B-P=-743/863, D-P=-1329/1450, D-O=-825/574, F-O=-629/1424, F-M=-1215/514, G-M=-3825/3587, B-Q=-3304/2884, G-I=-2584/2731

- NOTES-**
- Wind: ASCE 7-16; Vult=115mph (3-second gust) Vasd=91mph; TC DL=4.2psf; BCDL=5.0psf; h=30ft; Ke=1.00; Cat. II; Exp B; Enclosed; MWFRS (envelope) gable end zone; cantilever left and right exposed; end vertical left and right exposed; Lumber DOL=1.33 plate grip DOL=1.33
 - Truss designed for wind loads in the plane of the truss only. For studs exposed to wind (normal to the face), see Standard Industry Gable End Details as applicable, or consult qualified building designer as per ANSI/TPI 1.
 - TCLL: ASCE 7-16; Pf=25.0 psf (Lum DOL=1.15 Plate DOL=1.15); Is=1.0; Rough Cat B; Partially Exp.; Ce=1.0; Cs=1.00; Ct=1.10
 - Unbalanced snow loads have been considered for this design.
 - All plates are MT20 plates unless otherwise indicated.
 - All plates are 1.5x4 MT20 unless otherwise indicated.
 - Gable studs spaced at 2-0-0 oc.
 - This truss has been designed for a 10.0 psf bottom chord live load nonconcurrent with any other live loads.
 - * This truss has been designed for a live load of 20.0psf on the bottom chord in all areas where a rectangle 3-6-0 tall by 2-0-0 wide will fit between the bottom chord and any other members, with BCDL = 10.0psf.
 - All bearings are assumed to be SPF No.2 crushing capacity of 425 psi.
 - Provide mechanical connection (by others) of truss to bearing plate capable of withstanding 100 lb uplift at joint(s) J except (jt=lb) M=3032, Q=1657, I=2686, L=118.
 - This truss is designed in accordance with the 2018 International Building Code section 2306.1 and referenced standard ANSI/TPI 1.



September 12, 2024

Continued on page 2

WARNING - Verify design parameters and READ NOTES ON THIS AND INCLUDED MITEK REFERENCE PAGE MII-7473 rev. 6/30/2020 BEFORE USE.

Design valid for use only with MiTek® connectors. This design is based only upon parameters shown, and is for an individual building component, not a truss system. Before use, the building designer must verify the applicability of design parameters and properly incorporate this design into the overall building design. Bracing indicated is to prevent buckling of individual truss web and/or chord members only. Additional temporary and permanent bracing is always required for stability and to prevent collapse with possible personal injury and property damage. For general guidance regarding the fabrication, storage, delivery, erection and bracing of trusses and truss systems, see **ANSI/TPI1 Quality Criteria, DSB-89 and BCSI Building Component Safety Information** available from Truss Plate Institute, 2670 Crain Highway, Suite 203 Waldorf, MD 20601



240 Stirling Crescent
Bradford, ON. L3Z 4L5

Job	Truss	Truss Type	Qty	Ply	Buildings A-H
N0653A	P9	GABLE	1	1	U1530792

Alliance Truss (CA), Abbotsford, BC - V2S 7P6,

8.630 s Feb 9 2023 MiTek Industries, Inc. Thu Sep 12 16:09:49 2024 Page 2
ID:hFyjDMxrTsEK_kgkR0vWWVzFlgc-wSWIUdLJKP6Rg1mNhDR5z1aNhHOb9iTDJ_1lvCyeUeW

NOTES-

- 13) This truss has been designed for a total drag load of 240 plf. Lumber DOL=(1.33) Plate grip DOL=(1.33) Connect truss to resist drag loads along bottom chord from 19-5-8 to 26-10-0 for 873.2 plf.
- 14) This truss has large uplift reaction(s) from gravity load case(s). Proper connection is required to secure truss against upward movement at the bearings. Building designer must provide for uplift reactions indicated.
- 15) No notches allowed in overhang and 0 from left end and 0 from right end or 12" along rake from scarf, whichever is larger. Minimum 1.5x4 tie plates required at 2-0-0 o.c. maximum between the stacking chords. For edge-wise notching, provide at least one tie plate between each notch.



WARNING - Verify design parameters and READ NOTES ON THIS AND INCLUDED MITEK REFERENCE PAGE MII-7473 rev. 6/30/2020 BEFORE USE.

Design valid for use only with MiTek® connectors. This design is based only upon parameters shown, and is for an individual building component, not a truss system. Before use, the building designer must verify the applicability of design parameters and properly incorporate this design into the overall building design. Bracing indicated is to prevent buckling of individual truss web and/or chord members only. Additional temporary and permanent bracing is always required for stability and to prevent collapse with possible personal injury and property damage. For general guidance regarding the fabrication, storage, delivery, erection and bracing of trusses and truss systems, see

Safety Information available from Truss Plate Institute, 2670 Crain Highway, Suite 203 Waldorf, MD 20601
ANSI/TPI1 Quality Criteria, DSB-89 and BCSI Building Component



240 Stirling Crescent
Bradford, ON. L3Z 4L5

Job	Truss	Truss Type	Qty	Ply	Buildings A-H	U1530793
N0653A	P10	GABLE	1	1		

Alliance Truss (CA), Abbotsford, BC - V2S 7P6, 8.630 s Jul 12 2024 MiTek Industries, Inc. Thu Sep 12 02:47:34 2024 Page 1

ID:hFyjDMxrTsEK_kgkR0vWWVzFfgc-RfC?PsB70Hq3NSgPqnL8w3ulTXbGKWrCDoi7J4zJC?f

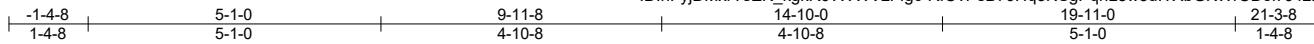

Scale = 1:40.0

4x8 ||
3x5 =

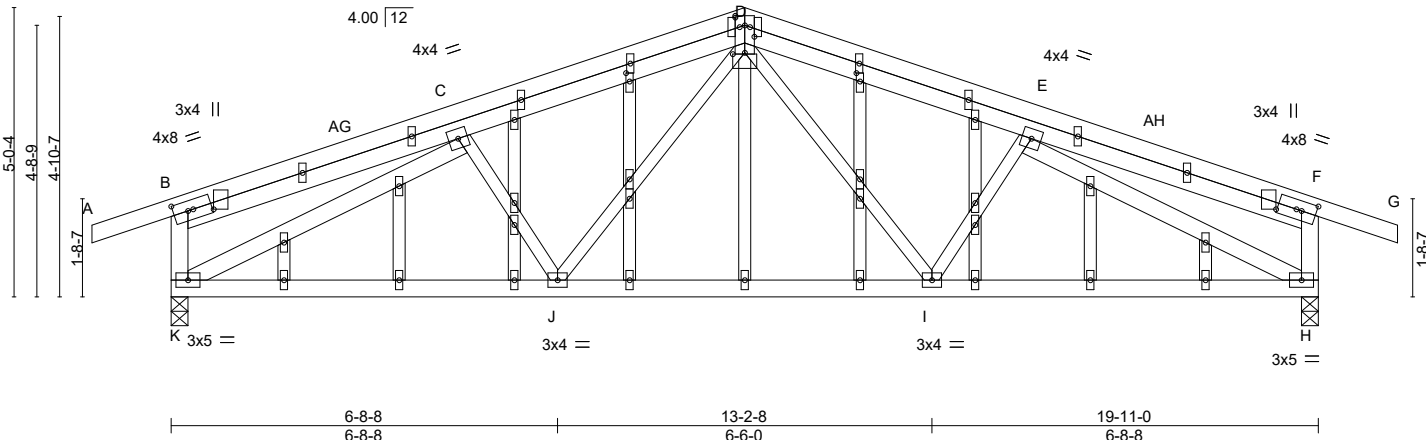

Plate Offsets (X,Y)-- [B:0-0-0,0-4-4], [B:0-3-0,0-2-0], [D:0-2-0,0-0-15], [D:0-2-0,0-2-0], [D:0-2-8,0-0-4], [D:0-2-0,0-0-15], [F:0-3-0,0-2-0], [F:0-0-0,0-4-4], [N:0-1-12,0-0-12], [W:0-1-12,0-0-12], [Y:0-0-0,0-0-0], [Y:0-0-0,0-0-0], [AB:0-0-0,0-0-0], [AB:0-0-0,0-0-0], [AF:0-0-0,0-0-0]

LOADING (psf)	SPACING-	CSI.	DEFL.	in (loc)	l/defl	L/d	PLATES	GRIP
TCLL 25.0 (Roof Snow=25.0)	2-0-0	TC 0.42	Vert(LL) -0.05	H-I	>999	360	MT20	197/144
TCDL 12.0	Lumber DOL 1.15	BC 0.43	Vert(CT) -0.11	H-I	>999	240		
BCLL 0.0 *	Rep Stress Incr YES	WB 0.81	Horz(CT) 0.04	H	n/a	n/a		
BCDL 10.0	Code IBC2018/TPI2014	Matrix-MS	Wind(LL) 0.03	I-J	>999	240	Weight: 119 lb	FT = 20%

LUMBER-
 TOP CHORD 2x4 SPF No.2
 BOT CHORD 2x4 SPF No.2
 WEBS 2x4 SPF No.2 *Except*
 D-I,E-I,D-J,C-J: 2x3 SPF No.2
 OTHERS 2x3 SPF No.2

BRACING-
 TOP CHORD Structural wood sheathing directly applied or 4-4-0 oc purlins, except end verticals.
 BOT CHORD Rigid ceiling directly applied or 10-0-0 oc bracing.

REACTIONS. (size) K=0-3-8, H=0-3-8
 Max Horz K=-31(LC 24)
 Max Uplift K=-139(LC 6), H=-139(LC 7)
 Max Grav K=1095(LC 17), H=1095(LC 18)

FORCES. (lb) - Max. Comp./Max. Ten. - All forces 250 (lb) or less except when shown.
 TOP CHORD C-D=-1380/138, D-E=-1380/138, B-K=-310/104, F-H=-310/104
 BOT CHORD J-K=-110/1342, I-J=-42/1016, H-I=-110/1342
 WEBS D-I=-31/403, D-J=-31/403, C-K=-1465/129, E-H=-1465/129

- NOTES-**
- 1) Wind: ASCE 7-16; Vult=115mph (3-second gust) Vasd=91mph; TCDL=4.2psf; BCDL=5.0psf; h=30ft; Ke=1.00; Cat. II; Exp B; Enclosed; MWFRS (envelope) gable end zone; cantilever left and right exposed; end vertical left and right exposed; Lumber DOL=1.33 plate grip DOL=1.33
 - 2) Truss designed for wind loads in the plane of the truss only. For studs exposed to wind (normal to the face), see Standard Industry Gable End Details as applicable, or consult qualified building designer as per ANSI/TPI 1.
 - 3) TCLL: ASCE 7-16; Pf=25.0 psf (Lum DOL=1.15 Plate DOL=1.15); Is=1.0; Rough Cat B; Partially Exp.; Ce=1.0; Cs=1.00; Ct=1.10
 - 4) Unbalanced snow loads have been considered for this design.
 - 5) This truss has been designed for greater of min roof live load of 20.0 psf or 2.00 times flat roof load of 25.0 psf on overhangs non-concurrent with other live loads.
 - 6) All plates are 1.5x4 MT20 unless otherwise indicated.
 - 7) Gable studs spaced at 2-0-0 oc.
 - 8) This truss has been designed for a 10.0 psf bottom chord live load nonconcurrent with any other live loads.
 - 9) * This truss has been designed for a live load of 20.0psf on the bottom chord in all areas where a rectangle 3-6-0 tall by 2-0-0 wide will fit between the bottom chord and any other members.
 - 10) Provide mechanical connection (by others) of truss to bearing plate capable of withstanding 100 lb uplift at joint(s) except (jt=lb) K=139, H=139.
 - 11) This truss is designed in accordance with the 2018 International Building Code section 2306.1 and referenced standard ANSI/TPI 1.
 - 12) No notches allowed in overhang and 10408 from left end and 10408 from right end or 12" along rake from scarf, whichever is larger. Minimum 1.5x4 tie plates required at 2-0-0 o.c. maximum between the stacking chords. For edge-wise notching, provide at least one tie plate between each notch.



September 12, 2024

WARNING - Verify design parameters and READ NOTES ON THIS AND INCLUDED MITEK REFERENCE PAGE MII-7473 rev. 6/30/2020 BEFORE USE.

Design valid for use only with MiTek® connectors. This design is based only upon parameters shown, and is for an individual building component, not a truss system. Before use, the building designer must verify the applicability of design parameters and properly incorporate this design into the overall building design. Bracing indicated is to prevent buckling of individual truss web and/or chord members only. Additional temporary and permanent bracing is always required for stability and to prevent collapse with possible personal injury and property damage. For general guidance regarding the fabrication, storage, delivery, erection and bracing of trusses and truss systems, see **ANSI/TPI1 Quality Criteria, DSB-89 and BCSI Building Component Safety Information** available from Truss Plate Institute, 2670 Crain Highway, Suite 203 Waldorf, MD 20601



240 Stirling Crescent
 Bradford, ON. L3Z 4L5

Job	Truss	Truss Type	Qty	Ply	Buildings A-H	U1530794
N0653A	R1	GABLE	1	1		

Alliance Truss (CA), Abbotsford, BC - V2S 7P6, 8.630 s Jul 12 2024 MiTek Industries, Inc. Thu Sep 12 02:47:41 2024 Page 1

ID:hFyjDMxrTsEK_kgkR0vWWVzFfgc-RfC?PsB70Hq3NSgPqnL8w3ulTXbGKWrCDoi7J4zJC?f

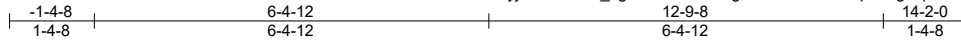

4x5 =

Scale = 1:37.4

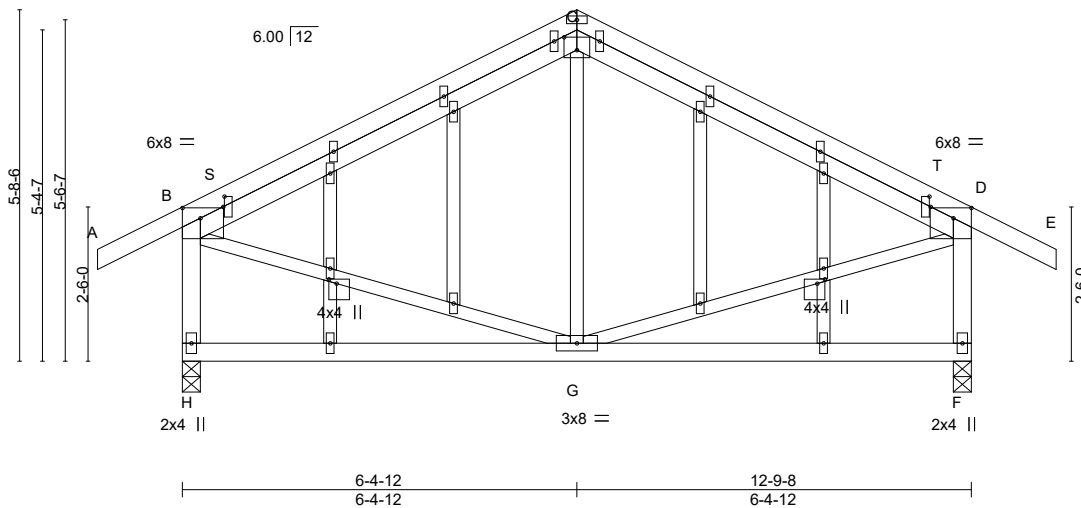

Plate Offsets (X,Y)-- [B:0-3-8,0-2-0], [C:0-2-8,0-2-8], [D:0-3-8,0-2-0], [K:0-0-14,0-1-8], [R:0-0-14,0-1-8], [S:0-2-0,0-0-4], [T:0-2-0,0-0-4]

LOADING (psf)	SPACING-	CSI.	DEFL.	PLATES	GRIP
TCLL 25.0 (Roof Snow=25.0)	2-0-0 Plate Grip DOL 1.15 Lumber DOL 1.15	TC 0.71 BC 0.28 WB 0.13 Matrix-MS	in (loc) l/defl L/d Vert(LL) -0.03 G-H >999 360 Vert(CT) -0.07 G-H >999 240 Horz(CT) 0.00 F n/a n/a Wind(LL) 0.00 G >999 240	MT20	197/144
TCDL 12.0	Rep Stress Incr YES			Weight: 79 lb	FT = 20%
BCLL 0.0 *	Code IBC2018/TPI2014				
BCDL 10.0					

LUMBER-

TOP CHORD 2x4 SPF No.2
 BOT CHORD 2x4 SPF No.2
 WEBS 2x3 SPF No.2 *Except*
 B-H,D-F: 2x4 SPF No.2
 OTHERS 2x3 SPF No.2

BRACING-

TOP CHORD Structural wood sheathing directly applied or 5-9-4 oc purlins, except end verticals.
 BOT CHORD Rigid ceiling directly applied or 6-0-0 oc bracing.

REACTIONS.

(size) H=0-3-8, F=0-3-8
 Max Horz H=93(LC 9)
 Max Uplift H=-74(LC 10), F=-74(LC 11)
 Max Grav H=802(LC 17), F=802(LC 18)

FORCES. (lb) - Max. Comp./Max. Ten. - All forces 250 (lb) or less except when shown.

TOP CHORD B-C=-594/62, C-D=-594/62, B-H=-742/99, D-F=-742/99
 WEBS B-G=0/383, D-G=0/383

NOTES-

- 1) Wind: ASCE 7-16; Vult=115mph (3-second gust) Vasd=91mph; TCDL=4.2psf; BCDL=5.0psf; h=30ft; Ke=1.00; Cat. II; Exp B; Enclosed; MWFRS (envelope) gable end zone; cantilever left and right exposed; end vertical left and right exposed; Lumber DOL=1.33 plate grip DOL=1.33
- 2) Truss designed for wind loads in the plane of the truss only. For studs exposed to wind (normal to the face), see Standard Industry Gable End Details as applicable, or consult qualified building designer as per ANSI/TPI 1.
- 3) TLL: ASCE 7-16; Pf=25.0 psf (Lum DOL=1.15 Plate DOL=1.15); Is=1.0; Rough Cat B; Partially Exp.; Ce=1.0; Cs=1.00; Ct=1.10
- 4) Unbalanced snow loads have been considered for this design.
- 5) This truss has been designed for greater of min roof live load of 18.0 psf or 2.00 times flat roof load of 25.0 psf on overhangs non-concurrent with other live loads.
- 6) All plates are 1.5x4 MT20 unless otherwise indicated.
- 7) Gable studs spaced at 2-0-0 oc.
- 8) This truss has been designed for a 10.0 psf bottom chord live load nonconcurrent with any other live loads.
- 9) * This truss has been designed for a live load of 20.0psf on the bottom chord in all areas where a rectangle 3-6-0 tall by 2-0-0 wide will fit between the bottom chord and any other members.
- 10) Provide mechanical connection (by others) of truss to bearing plate capable of withstanding 100 lb uplift at joint(s) H, F.
- 11) This truss is designed in accordance with the 2018 International Building Code section 2306.1 and referenced standard ANSI/TPI 1.
- 12) No notches allowed in overhang and 10408 from left end and 10408 from right end or 12" along rake from scarf, whichever is larger. Minimum 1.5x4 tie plates required at 2-0-0 o.c. maximum between the stacking chords. For edge-wise notching, provide at least one tie plate between each notch.



September 12, 2024

WARNING - Verify design parameters and READ NOTES ON THIS AND INCLUDED MITEK REFERENCE PAGE MII-7473 rev. 6/30/2020 BEFORE USE.

Design valid for use only with MiTek® connectors. This design is based only upon parameters shown, and is for an individual building component, not a truss system. Before use, the building designer must verify the applicability of design parameters and properly incorporate this design into the overall building design. Bracing indicated is to prevent buckling of individual truss web and/or chord members only. Additional temporary and permanent bracing is always required for stability and to prevent collapse with possible personal injury and property damage. For general guidance regarding the fabrication, storage, delivery, erection and bracing of trusses and truss systems, see **ANSI/TPI1 Quality Criteria, DSB-89 and BCSI Building Component Safety Information** available from Truss Plate Institute, 2670 Crain Highway, Suite 203 Waldorf, MD 20601



240 Stirling Crescent
 Bradford, ON. L3Z 4L5

Job	Truss	Truss Type	Qty	Ply	Buildings A-H	U1530858
N0653A	R2	Common	3	1		

Job Reference (optional)

Alliance Truss (CA), Abbotsford, BC - V2S 7P6,

8.820 s Aug 30 2024 MiTek Industries, Inc. Thu Sep 12 02:48:18 2024 Page 1

ID:hFyjDMxrTsEK_kgkR0vWWVzFlgc-o0TVQwCmAcknUamulPB1UdWYchHMhsTJ2XIRkByeVqx

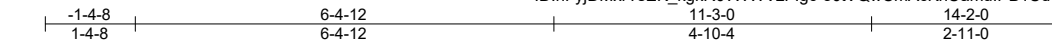

4x5 =

Scale = 1:35.2

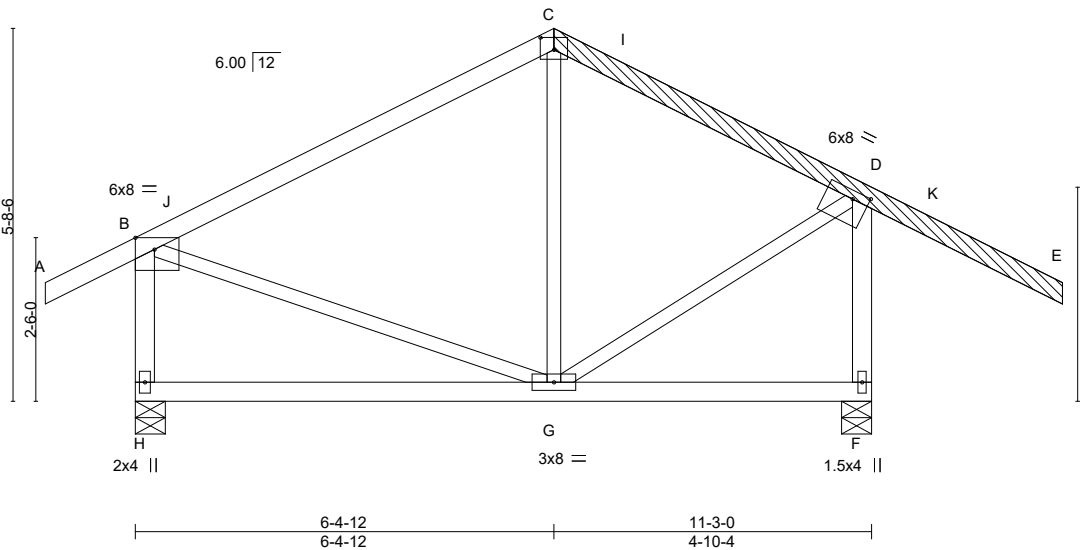

Plate Offsets (X,Y)-- [B:0-3-8,Edge], [C:0-2-8,0-2-4], [D:0-3-0,0-1-8]

LOADING (psf)	SPACING-	CSI.	DEFL.	in (loc)	l/defl	L/d	PLATES	GRIP
TCLL 25.0 (Roof Snow=25.0)	2-0-0 Plate Grip DOL 1.15	TC 0.71	Vert(LL)	-0.04 G-H	>999	360	MT20	197/144
TCDL 12.0	Lumber DOL 1.15	BC 0.25	Vert(CT)	-0.08 G-H	>999	240		
BCLL 0.0 *	Rep Stress Incr YES	WB 0.12	Horz(CT)	-0.00 F	n/a	n/a		
BCDL 10.0	Code IBC2018/TPI2014	Matrix-MS	Wind(LL)	0.00 G	>999	240	Weight: 62 lb	FT = 20%

LUMBER-

TOP CHORD 2x4 SPF No.2
 BOT CHORD 2x4 SPF No.2
 WEBS 2x3 SPF No.2 *Except*
 B-H,D-F: 2x4 SPF No.2
 OTHERS 2x4 SPF No.2
 LBR SCAB C-E 2x4 SPF No.2 one side

BRACING-

TOP CHORD Structural wood sheathing directly applied or 6-0-0 oc purlins, except end verticals.
 BOT CHORD Rigid ceiling directly applied or 6-0-0 oc bracing.

REACTIONS.

(size) H=0-5-8, F=0-5-8
 Max Horz H=114(LC 9)
 Max Uplift H=-70(LC 10), F=-95(LC 11)
 Max Grav H=729(LC 17), F=882(LC 18)

FORCES. (lb) - Max. Comp./Max. Ten. - All forces 250 (lb) or less except when shown.

TOP CHORD B-C=-478/47, C-D=-400/68, B-H=-668/97, D-F=-847/111
 WEBS D-G=0/353

NOTES-

- Attached 8-10-0 scab C to E, front face(s) 2x4 SPF No.2 with 1 row(s) of 10d (0.131"x3") nails spaced 9" o.c.except : starting at 4-3-3 from end at joint C, nail 1 row(s) at 4" o.c. for 2-11-11.
- Wind: ASCE 7-16; Vult=115mph (3-second gust) Vasd=91mph; TCDL=4.2psf; BCDL=5.0psf; h=30ft; Ke=1.00; Cat. II; Exp B; Enclosed; MWFRS (envelope) gable end zone; cantilever left and right exposed ; end vertical left and right exposed; Lumber DOL=1.33 plate grip DOL=1.33
- TCLL: ASCE 7-16; Pf=25.0 psf (Lum DOL = 1.15 Plate DOL = 1.15); Is=1.0; Rough Cat B; Partially Exp.; Ce=1.0; Cs=1.00; Ct=1.10
- Unbalanced snow loads have been considered for this design.
- This truss has been designed for greater of min roof live load of 18.0 psf or 2.00 times flat roof load of 25.0 psf on overhangs non-concurrent with other live loads.
- This truss has been designed for a 10.0 psf bottom chord live load nonconcurrent with any other live loads.
- * This truss has been designed for a live load of 20.0psf on the bottom chord in all areas where a rectangle 3-6-0 tall by 2-0-0 wide will fit between the bottom chord and any other members.
- Provide mechanical connection (by others) of truss to bearing plate capable of withstanding 100 lb uplift at joint(s) H, F.
- This truss is designed in accordance with the 2018 International Building Code section 2306.1 and referenced standard ANSI/TPI 1.



September 12,2024

WARNING - Verify design parameters and READ NOTES ON THIS AND INCLUDED MITEK REFERENCE PAGE MII-7473 rev. 6/30/2020 BEFORE USE.

Design valid for use only with MiTek® connectors. This design is based only upon parameters shown, and is for an individual building component, not a truss system. Before use, the building designer must verify the applicability of design parameters and properly incorporate this design into the overall building design. Bracing indicated is to prevent buckling of individual truss web and/or chord members only. Additional temporary and permanent bracing is always required for stability and to prevent collapse with possible personal injury and property damage. For general guidance regarding the fabrication, storage, delivery, erection and bracing of trusses and truss systems, see

ANSI/TPI1 Quality Criteria, DSB-89 and BCSI Building Component

Safety Information available from Truss Plate Institute, 2670 Crain Highway, Suite 203 Waldorf, MD 20601



240 Stirling Crescent
 Bradford, ON. L3Z 4L5

Job	Truss	Truss Type	Qty	Ply	Buildings A-H	U1530795
N0653A	S1	BLOCKING SUPPORTED	75	1		

Alliance Truss (CA), Abbotsford, BC - V2S 7P6,

8.630 s Jul 12 2024 MiTek Industries, Inc. Thu Sep 12 02:47:42 2024 Page 1

ID:hFyjDMxrTsEK_kgkR0vWWVzFgC-RfC?PsB70Hq3NSgPqnL8w3ulTXbGKWrCDoi7J4zJC?f

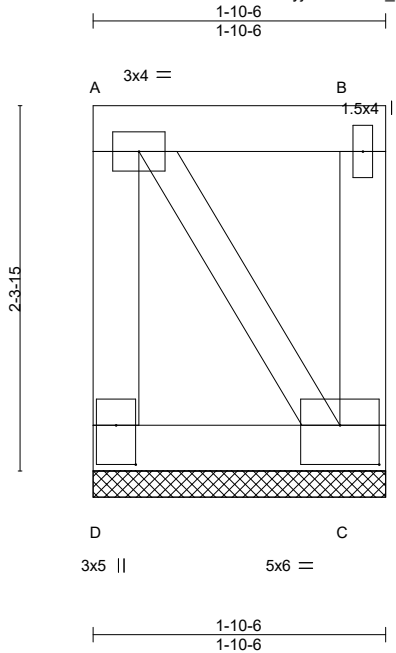

Scale = 1:14.7

Plate Offsets (X,Y)-- [C:0-3-0,0-3-0], [D:0-3-0,0-1-8]

LOADING (psf)	SPACING-	CSI.	DEFL.	PLATES	GRIP
TCLL 25.0 (Roof Snow=25.0)	2-0-0 Plate Grip DOL 1.15 Lumber DOL 1.15 Rep Stress Incr YES Code IBC2018/TPI2014	TC 0.12 BC 0.08 WB 0.20 Matrix-P	in (loc) l/defl L/d Vert(LL) n/a - n/a 999 Vert(CT) n/a - n/a 999 Horz(CT) -0.00 C n/a n/a	MT20	197/144
TCDL 12.0				Weight: 10 lb	FT = 20%
BCLL 0.0 *					
BCDL 10.0					

LUMBER-

TOP CHORD 2x4 SPF No.2
 BOT CHORD 2x4 SPF No.2
 WEBS 2x4 SPF No.2 *Except*
 A-C: 2x3 SPF No.2

BRACING-

TOP CHORD Structural wood sheathing directly applied or 1-10-6 oc purlins, except end verticals.
 BOT CHORD Rigid ceiling directly applied or 6-0-0 oc bracing.

REACTIONS.

(size) D=1-10-6, C=1-10-6
 Max Horz D=58(LC 5)
 Max Uplift D=-535(LC 24), C=-535(LC 27)
 Max Grav D=544(LC 31), C=544(LC 28)

FORCES. (lb) - Max. Comp./Max. Ten. - All forces 250 (lb) or less except when shown.

TOP CHORD A-D=-528/543, A-B=-361/356
 BOT CHORD C-D=-390/385
 WEBS A-C=-665/665

NOTES-

- 1) Wind: ASCE 7-16; Vult=115mph (3-second gust) Vasd=91mph; TCDL=4.2psf; BCDL=5.0psf; h=30ft; Ke=1.00; Cat. II; Exp B; Enclosed; MWFRS (envelope) gable end zone; cantilever left and right exposed; end vertical left and right exposed; Lumber DOL=1.33 plate grip DOL=1.33
- 2) Truss designed for wind loads in the plane of the truss only. For studs exposed to wind (normal to the face), see Standard Industry Gable End Details as applicable, or consult qualified building designer as per ANSI/TPI 1.
- 3) TCELL: ASCE 7-16; Pf=25.0 psf (Lum DOL=1.15 Plate DOL=1.15); Is=1.0; Rough Cat B; Partially Exp.; Ce=1.0; Cs=1.00; Ct=1.10
- 4) Provide adequate drainage to prevent water ponding.
- 5) Gable requires continuous bottom chord bearing.
- 6) Truss to be fully sheathed from one face or securely braced against lateral movement (i.e. diagonal web).
- 7) Gable studs spaced at 2-0-0 oc.
- 8) This truss has been designed for a 10.0 psf bottom chord live load nonconcurrent with any other live loads.
- 9) * This truss has been designed for a live load of 20.0psf on the bottom chord in all areas where a rectangle 3-6-0 tall by 2-0-0 wide will fit between the bottom chord and any other members.
- 10) Provide mechanical connection (by others) of truss to bearing plate capable of withstanding 100 lb uplift at joint(s) except (jt=lb) D=535, C=535.
- 11) This truss is designed in accordance with the 2018 International Building Code section 2306.1 and referenced standard ANSI/TPI 1.
- 12) This truss has been designed for a total drag load of 240 pif. Lumber DOL=(1.33) Plate grip DOL=(1.33) Connect truss to resist drag loads along bottom chord from 0-0-0 to 1-10-6 for 240.0 pif.



September 12,2024

WARNING - Verify design parameters and READ NOTES ON THIS AND INCLUDED MITEK REFERENCE PAGE MII-7473 rev. 6/30/2020 BEFORE USE.

Design valid for use only with MiTek® connectors. This design is based only upon parameters shown, and is for an individual building component, not a truss system. Before use, the building designer must verify the applicability of design parameters and properly incorporate this design into the overall building design. Bracing indicated is to prevent buckling of individual truss web and/or chord members only. Additional temporary and permanent bracing is always required for stability and to prevent collapse with possible personal injury and property damage. For general guidance regarding the fabrication, storage, delivery, erection and bracing of trusses and truss systems, see **ANSI/TPI1 Quality Criteria, DSB-89 and BCSI Building Component Safety Information** available from Truss Plate Institute, 2670 Crain Highway, Suite 203 Waldorf, MD 20601



240 Stirling Crescent
 Bradford, ON. L3Z 4L5

Job	Truss	Truss Type	Qty	Ply	Buildings A-H	U1530859
N0653A	S2	BLOCKING SUPPORTED	117	1		

Alliance Truss (CA), Abbotsford, BC - V2S 7P6,

8.820 s Aug 30 2024 MiTek Industries, Inc. Thu Sep 12 02:48:20 2024 Page 1

ID:hFyjDMxrTsEK_kgkR0vWWVzF1gc-kP_FrcE1iEbVkuvGQqDVZ2bvU_U9dlcVrEYp4yeVqv

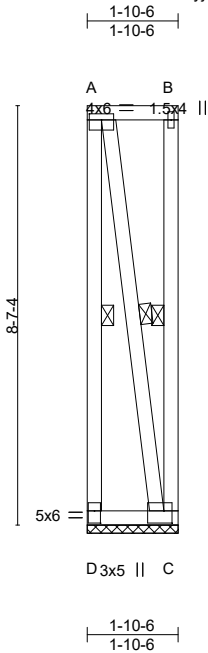

Scale = 1:47.3

Plate Offsets (X,Y)-- [A:0-3-0,0-1-8], [C:0-2-0,0-3-0], [D:0-3-0,0-1-8]

LOADING (psf)	SPACING-	CSI.	DEFL.	in (loc)	l/defl	L/d	PLATES	GRIP
TCLL 25.0 (Roof Snow=25.0)	2-0-0 Plate Grip DOL 1.15 Lumber DOL 1.15	TC 0.66 BC 0.08 WB 0.68 Matrix-P	Vert(LL)	n/a	-	n/a	MT20	197/144
TCDL 12.0	Rep Stress Incr NO		Vert(CT)	n/a	-	n/a		
BCLL 0.0 *	Code IBC2018/TPI2014		Horz(CT)	0.00	C	n/a		
BCDL 10.0							Weight: 32 lb	FT = 20%

LUMBER-

TOP CHORD 2x4 SPF No.2
 BOT CHORD 2x4 SPF No.2
 WEBS 2x4 SPF No.2

BRACING-

TOP CHORD Structural wood sheathing directly applied or 1-10-6 oc purlins, except end verticals.
 BOT CHORD Rigid ceiling directly applied or 6-0-0 oc bracing.
 WEBS 1 Row at midpt A-D, B-C, A-C

REACTIONS.

(size) D=1-10-6, C=1-10-6
 Max Uplift D=-2005(LC 23), C=-2005(LC 24)
 Max Grav D=2030(LC 44), C=2030(LC 43)

FORCES. (lb) - Max. Comp./Max. Ten. - All forces 250 (lb) or less except when shown.

TOP CHORD A-D=-2014/2013, A-B=-340/340
 BOT CHORD C-D=-340/340
 WEBS A-C=-2031/2031

NOTES-

- 1) Wind: ASCE 7-16; Vult=115mph (3-second gust) Vasd=91mph; TCDL=4.2psf; BCDL=5.0psf; h=30ft; Ke=1.00; Cat. II; Exp B; Enclosed; MWFRS (envelope) gable end zone; Lumber DOL=1.33 plate grip DOL=1.33
- 2) TCLL: ASCE 7-16; Pf=25.0 psf (Lum DOL = 1.15 Plate DOL = 1.15); Is=1.0; Rough Cat B; Partially Exp.; Ce=1.0; Cs=1.00; Ct=1.10
- 3) Provide adequate drainage to prevent water ponding.
- 4) Gable requires continuous bottom chord bearing.
- 5) This truss has been designed for a 10.0 psf bottom chord live load nonconcurrent with any other live loads.
- 6) * This truss has been designed for a live load of 20.0psf on the bottom chord in all areas where a rectangle 3-6-0 tall by 2-0-0 wide will fit between the bottom chord and any other members.
- 7) Provide mechanical connection (by others) of truss to bearing plate capable of withstanding 100 lb uplift at joint(s) except (jt=lb) D=2005, C=2005.
- 8) This truss is designed in accordance with the 2018 International Building Code section 2306.1 and referenced standard ANSI/TPI 1.
- 9) This truss has been designed for a total drag load of 240 plf. Lumber DOL=(1.33) Plate grip DOL=(1.33) Connect truss to resist drag loads along bottom chord from 0-0-0 to 1-10-6 for 240.0 plf.



September 12, 2024

WARNING - Verify design parameters and READ NOTES ON THIS AND INCLUDED MITEK REFERENCE PAGE MII-7473 rev. 6/30/2020 BEFORE USE.

Design valid for use only with MiTek® connectors. This design is based only upon parameters shown, and is for an individual building component, not a truss system. Before use, the building designer must verify the applicability of design parameters and properly incorporate this design into the overall building design. Bracing indicated is to prevent buckling of individual truss web and/or chord members only. Additional temporary and permanent bracing is always required for stability and to prevent collapse with possible personal injury and property damage. For general guidance regarding the fabrication, storage, delivery, erection and bracing of trusses and truss systems, see

Safety Information available from Truss Plate Institute, 2670 Crain Highway, Suite 203 Waldorf, MD 20601

ANSI/TPI1 Quality Criteria, DSB-89 and BCSI Building Component



240 Stirling Crescent
 Bradford, ON. L3Z 4L5

Job	Truss	Truss Type	Qty	Ply	Buildings A-H	U1530860
N0653A	S3	BLOCKING SUPPORTED	117	1		

Alliance Truss (CA), Abbotsford, BC - V2S 7P6,

8.820 s Aug 30 2024 MiTek Industries, Inc. Thu Sep 12 02:48:21 2024 Page 1

ID:hFyjDMxrTsEK_kgkR0vWWVzFlgc-CbYd3yFTXjML1UTzYkk5F84PuKpu4HlkVz5LWyeVqu

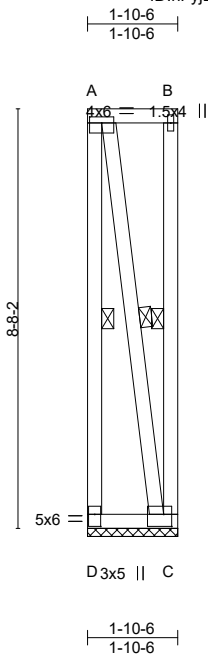

Scale: 1/4"=1'

Plate Offsets (X,Y)-- [A:0-3-0,0-1-8], [C:0-2-0,0-3-0], [D:0-3-0,0-1-8]

LOADING (psf)	SPACING-	CSI.	DEFL.	in (loc)	l/defl	L/d	PLATES	GRIP
TCLL 25.0 (Roof Snow=25.0)	2-0-0 Plate Grip DOL 1.15	TC 0.68	Vert(LL)	n/a	-	n/a	MT20	197/144
TCDL 12.0	Lumber DOL 1.15	BC 0.07	Vert(CT)	n/a	-	n/a		
BCLL 0.0 *	Rep Stress Incr YES	WB 0.69	Horz(CT)	0.00	C	n/a		
BCDL 10.0	Code IBC2018/TPI2014	Matrix-P					Weight: 32 lb	FT = 20%

LUMBER-

TOP CHORD 2x4 SPF No.2
 BOT CHORD 2x4 SPF No.2
 WEBS 2x4 SPF No.2

BRACING-

TOP CHORD Structural wood sheathing directly applied or 1-10-6 oc purlins, except end verticals.
 BOT CHORD Rigid ceiling directly applied or 6-0-0 oc bracing.
 WEBS 1 Row at midpt A-D, B-C, A-C

REACTIONS.

(size) D=1-10-6, C=1-10-6
 Max Uplift D=-2022(LC 23), C=-2022(LC 24)
 Max Grav D=2047(LC 44), C=2047(LC 43)

FORCES. (lb) - Max. Comp./Max. Ten. - All forces 250 (lb) or less except when shown.

TOP CHORD A-D=-2031/2029, A-B=-340/340
 BOT CHORD C-D=-340/340
 WEBS A-C=-2047/2047

NOTES-

- 1) Wind: ASCE 7-16; Vult=115mph (3-second gust) Vasd=91mph; TCDL=4.2psf; BCDL=5.0psf; h=30ft; Ke=1.00; Cat. II; Exp B; Enclosed; MWFRS (envelope) gable end zone; Lumber DOL=1.33 plate grip DOL=1.33
- 2) TCLL: ASCE 7-16; Pf=25.0 psf (Lum DOL = 1.15 Plate DOL = 1.15); Is=1.0; Rough Cat B; Partially Exp.; Ce=1.0; Cs=1.00; Ct=1.10
- 3) Provide adequate drainage to prevent water ponding.
- 4) Gable requires continuous bottom chord bearing.
- 5) This truss has been designed for a 10.0 psf bottom chord live load nonconcurrent with any other live loads.
- 6) * This truss has been designed for a live load of 20.0psf on the bottom chord in all areas where a rectangle 3-6-0 tall by 2-0-0 wide will fit between the bottom chord and any other members.
- 7) Provide mechanical connection (by others) of truss to bearing plate capable of withstanding 100 lb uplift at joint(s) except (jt=lb) D=2022, C=2022.
- 8) This truss is designed in accordance with the 2018 International Building Code section 2306.1 and referenced standard ANSI/TPI 1.
- 9) This truss has been designed for a total drag load of 240 plf. Lumber DOL=(1.33) Plate grip DOL=(1.33) Connect truss to resist drag loads along bottom chord from 0-0-0 to 1-10-6 for 240.0 plf.



September 12, 2024

WARNING - Verify design parameters and READ NOTES ON THIS AND INCLUDED MITEK REFERENCE PAGE MII-7473 rev. 6/30/2020 BEFORE USE.

Design valid for use only with MiTek® connectors. This design is based only upon parameters shown, and is for an individual building component, not a truss system. Before use, the building designer must verify the applicability of design parameters and properly incorporate this design into the overall building design. Bracing indicated is to prevent buckling of individual truss web and/or chord members only. Additional temporary and permanent bracing is always required for stability and to prevent collapse with possible personal injury and property damage. For general guidance regarding the fabrication, storage, delivery, erection and bracing of trusses and truss systems, see

Safety Information available from Truss Plate Institute, 2670 Crain Highway, Suite 203 Waldorf, MD 20601



240 Stirling Crescent
 Bradford, ON. L3Z 4L5

ANSI/TPI1 Quality Criteria, DSB-89 and BCSI Building Component

Job	Truss	Truss Type	Qty	Ply	Buildings A-H	U1530861
N0653A	S3A	BLOCKING SUPPORTED	1	1		

Alliance Truss (CA), Abbotsford, BC - V2S 7P6,

8.820 s Aug 30 2024 MiTek Industries, Inc. Thu Sep 12 02:48:21 2024 Page 1

ID:hFyjDMxrTsEK_kgkR0vWWVzFlgc-CbYd3yFTXjML1UTzYkk5F84QuLyu4QlkVz5LWyeVqu

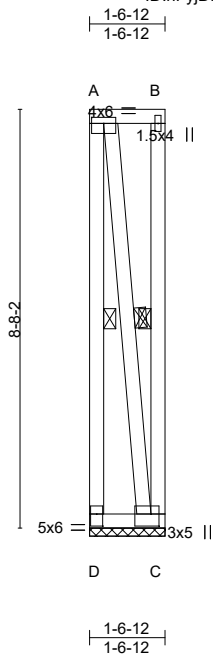

Scale: 1/4"=1'

Plate Offsets (X,Y)-- [A:0-3-0,0-1-8], [C:0-2-0,0-3-0], [D:0-3-0,0-1-8]

LOADING (psf)		SPACING-		CSI.		DEFL.		PLATES		GRIP	
TCLL	25.0	Plate Grip DOL	1.15	TC	0.68	Vert(LL)	n/a - n/a	999	MT20	197/144	
(Roof Snow=25.0)		Lumber DOL	1.15	BC	0.06	Vert(CT)	n/a - n/a	999			
TCDL	12.0	Rep Stress Incr	NO	WB	0.68	Horz(CT)	0.00 C	n/a			
BCLL	0.0 *	Code IBC2018/TPI2014		Matrix-P					Weight: 31 lb	FT = 20%	
BCDL	10.0										

LUMBER-

TOP CHORD 2x4 SPF No.2
 BOT CHORD 2x4 SPF No.2
 WEBS 2x4 SPF No.2

BRACING-

TOP CHORD Structural wood sheathing directly applied or 1-6-12 oc purlins, except end verticals.
 BOT CHORD Rigid ceiling directly applied or 6-0-0 oc bracing.
 WEBS 1 Row at midpt A-D, B-C, A-C

REACTIONS.

(size) D=1-6-12, C=1-6-12
 Max Uplift D=-2020(LC 23), C=-2020(LC 24)
 Max Grav D=2040(LC 44), C=2040(LC 43)

FORCES. (lb) - Max. Comp./Max. Ten. - All forces 250 (lb) or less except when shown.

TOP CHORD A-D=-2027/2026, A-B=-274/274
 BOT CHORD C-D=-275/275
 WEBS A-C=-2035/2035

NOTES-

- 1) Wind: ASCE 7-16; Vult=115mph (3-second gust) Vasd=91mph; TCDL=4.2psf; BCDL=5.0psf; h=30ft; Ke=1.00; Cat. II; Exp B; Enclosed; MWFRS (envelope) gable end zone; Lumber DOL=1.33 plate grip DOL=1.33
- 2) TCLL: ASCE 7-16; Pf=25.0 psf (Lum DOL = 1.15 Plate DOL = 1.15); Is=1.0; Rough Cat B; Partially Exp.; Ce=1.0; Cs=1.00; Ct=1.10
- 3) Provide adequate drainage to prevent water ponding.
- 4) Gable requires continuous bottom chord bearing.
- 5) This truss has been designed for a 10.0 psf bottom chord live load nonconcurrent with any other live loads.
- 6) * This truss has been designed for a live load of 20.0psf on the bottom chord in all areas where a rectangle 3-6-0 tall by 2-0-0 wide will fit between the bottom chord and any other members.
- 7) Provide mechanical connection (by others) of truss to bearing plate capable of withstanding 100 lb uplift at joint(s) except (jt=lb) D=2020, C=2020.
- 8) This truss is designed in accordance with the 2018 International Building Code section 2306.1 and referenced standard ANSI/TPI 1.
- 9) This truss has been designed for a total drag load of 240 plf. Lumber DOL=(1.33) Plate grip DOL=(1.33) Connect truss to resist drag loads along bottom chord from 0-0-0 to 1-6-12 for 240.0 plf.



September 12, 2024

WARNING - Verify design parameters and READ NOTES ON THIS AND INCLUDED MITEK REFERENCE PAGE MII-7473 rev. 6/30/2020 BEFORE USE.

Design valid for use only with MiTek® connectors. This design is based only upon parameters shown, and is for an individual building component, not a truss system. Before use, the building designer must verify the applicability of design parameters and properly incorporate this design into the overall building design. Bracing indicated is to prevent buckling of individual truss web and/or chord members only. Additional temporary and permanent bracing is always required for stability and to prevent collapse with possible personal injury and property damage. For general guidance regarding the fabrication, storage, delivery, erection and bracing of trusses and truss systems, see

Safety Information available from Truss Plate Institute, 2670 Crain Highway, Suite 203 Waldorf, MD 20601

ANSI/TPI1 Quality Criteria, DSB-89 and BCSI Building Component



240 Stirling Crescent
 Bradford, ON. L3Z 4L5

Job	Truss	Truss Type	Qty	Ply	Buildings A-H	U1530862
N0653A	S4	BLOCKING SUPPORTED	88	1		

Alliance Truss (CA), Abbotsford, BC - V2S 7P6,

8.820 s Aug 30 2024 MiTek Industries, Inc. Thu Sep 12 02:48:22 2024 Page 1

ID:hFyjDMxrTsEK_kgkR0vWWVzFfgc-gn6?GIFHErrDzB3fXFGzeTgEElgjdUFvy9jftyVqt

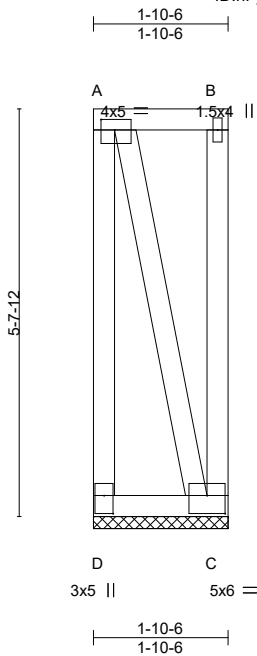

Scale: 3/8"=1'

Plate Offsets (X,Y)-- [A:0-2-4,0-1-12], [C:0-3-0,0-3-0], [D:0-3-0,0-1-8]

LOADING (psf)	SPACING-	CSI.	DEFL.	in (loc)	l/defl	L/d	PLATES	GRIP
TCLL 25.0 (Roof Snow=25.0)	2-0-0 Plate Grip DOL 1.15 Lumber DOL 1.15	TC 0.74 BC 0.09 WB 0.84 Matrix-P	Vert(LL) Vert(CT) Horz(CT)	n/a n/a -0.00	- - C	n/a n/a n/a	MT20	197/144
TCDL 12.0	Rep Stress Incr YES						Weight: 22 lb	FT = 20%
BCLL 0.0 *	Code IBC2018/TPI2014							
BCDL 10.0								

LUMBER-

TOP CHORD 2x4 SPF No.2
 BOT CHORD 2x4 SPF No.2
 WEBS 2x4 SPF No.2

BRACING-

TOP CHORD Structural wood sheathing directly applied or 1-10-6 oc purlins, except end verticals.
 BOT CHORD Rigid ceiling directly applied or 6-0-0 oc bracing.

REACTIONS.

(size) D=1-10-6, C=1-10-6
 Max Horz D=-151(LC 4)
 Max Uplift D=-1553(LC 24), C=-1553(LC 27)
 Max Grav D=1561(LC 31), C=1561(LC 28)

FORCES. (lb) - Max. Comp./Max. Ten. - All forces 250 (lb) or less except when shown.

TOP CHORD A-D=-1545/1561, A-B=-396/382
 BOT CHORD C-D=-472/458
 WEBS A-C=-1609/1609

NOTES-

- 1) Wind: ASCE 7-16; Vult=115mph (3-second gust) Vasd=91mph; TCDL=4.2psf; BCDL=5.0psf; h=30ft; Ke=1.00; Cat. II; Exp B; Enclosed; MWFRS (envelope) gable end zone; cantilever left and right exposed ; end vertical left and right exposed; Lumber DOL=1.33 plate grip DOL=1.33
- 2) Truss designed for wind loads in the plane of the truss only. For studs exposed to wind (normal to the face), see Standard Industry Gable End Details as applicable, or consult qualified building designer as per ANSI/TPI 1.
- 3) TCLL: ASCE 7-16; Pf=25.0 psf (Lum DOL = 1.15 Plate DOL = 1.15); Is=1.0; Rough Cat B; Partially Exp.; Ce=1.0; Cs=1.00; Ct=1.10
- 4) Provide adequate drainage to prevent water ponding.
- 5) Gable requires continuous bottom chord bearing.
- 6) Truss to be fully sheathed from one face or securely braced against lateral movement (i.e. diagonal web).
- 7) Gable studs spaced at 2-0-0 oc.
- 8) This truss has been designed for a 10.0 psf bottom chord live load nonconcurrent with any other live loads.
- 9) * This truss has been designed for a live load of 20.0psf on the bottom chord in all areas where a rectangle 3-6-0 tall by 2-0-0 wide will fit between the bottom chord and any other members.
- 10) Provide mechanical connection (by others) of truss to bearing plate capable of withstanding 100 lb uplift at joint(s) except (jt=lb) D=1553, C=1553.
- 11) This truss is designed in accordance with the 2018 International Building Code section 2306.1 and referenced standard ANSI/TPI 1.
- 12) This truss has been designed for a total drag load of 240 plf. Lumber DOL=(1.33) Plate grip DOL=(1.33) Connect truss to resist drag loads along bottom chord from 0-0-0 to 1-10-6 for 240.0 plf.



September 12, 2024

WARNING - Verify design parameters and READ NOTES ON THIS AND INCLUDED MITEK REFERENCE PAGE MII-7473 rev. 6/30/2020 BEFORE USE.

Design valid for use only with MiTek® connectors. This design is based only upon parameters shown, and is for an individual building component, not a truss system. Before use, the building designer must verify the applicability of design parameters and properly incorporate this design into the overall building design. Bracing indicated is to prevent buckling of individual truss web and/or chord members only. Additional temporary and permanent bracing is always required for stability and to prevent collapse with possible personal injury and property damage. For general guidance regarding the fabrication, storage, delivery, erection and bracing of trusses and truss systems, see

Safety Information available from Truss Plate Institute, 2670 Crain Highway, Suite 203 Waldorf, MD 20601

ANSI/TPI1 Quality Criteria, DSB-89 and BCSI Building Component



240 Stirling Crescent
 Bradford, ON. L3Z 4L5

Job	Truss	Truss Type	Qty	Ply	Buildings A-H	U1530863
N0653A	S5	BLOCKING SUPPORTED	22	1		

Alliance Truss (CA), Abbotsford, BC - V2S 7P6,

8.820 s Aug 30 2024 MiTek Industries, Inc. Thu Sep 12 02:48:23 2024 Page 1

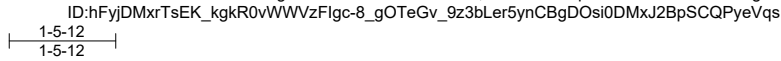

Scale: 3/8"=1'

Plate Offsets (X,Y)-- [A:0-2-8,0-1-8], [C:0-3-0,0-3-0], [D:0-3-0,0-1-8]

LOADING (psf)	SPACING-	CSI.	DEFL.	in (loc)	l/defl	L/d	PLATES	GRIP
TCLL 25.0 (Roof Snow=25.0)	2-0-0 Plate Grip DOL 1.15 Lumber DOL 1.15	TC 0.81 BC 0.07 WB 0.85 Matrix-P	Vert(LL) Vert(CT) Horz(CT)	n/a n/a -0.00	- - C	n/a n/a n/a	999 999	MT20 197/144
TCDL 12.0	Rep Stress Incr YES Code IBC2018/TPI2014							
BCLL 0.0 *								
BCDL 10.0							Weight: 21 lb	FT = 20%

LUMBER-	BRACING-
TOP CHORD 2x4 SPF No.2	TOP CHORD Structural wood sheathing directly applied or 1-5-12 oc purlins, except end verticals.
BOT CHORD 2x4 SPF No.2	BOT CHORD Rigid ceiling directly applied or 6-0-0 oc bracing.
WEBS 2x4 SPF No.2	

REACTIONS. (size) D=1-5-12, C=1-5-12
 Max Horz D=-152(LC 25)
 Max Uplift D=-1634(LC 24), C=-1634(LC 27)
 Max Grav D=1640(LC 31), C=1640(LC 28)

FORCES. (lb) - Max. Comp./Max. Ten. - All forces 250 (lb) or less except when shown.
 TOP CHORD A-D=-1629/1640, A-B=-313/299
 BOT CHORD C-D=-389/375
 WEBS A-C=-1667/1667

- NOTES-**
- 1) Wind: ASCE 7-16; Vult=115mph (3-second gust) Vasd=91mph; TCDL=4.2psf; BCDL=5.0psf; h=30ft; Ke=1.00; Cat. II; Exp B; Enclosed; MWFRS (envelope) gable end zone; cantilever left and right exposed ; end vertical left and right exposed; Lumber DOL=1.33 plate grip DOL=1.33
 - 2) Truss designed for wind loads in the plane of the truss only. For studs exposed to wind (normal to the face), see Standard Industry Gable End Details as applicable, or consult qualified building designer as per ANSI/TPI 1.
 - 3) TCLL: ASCE 7-16; Pf=25.0 psf (Lum DOL = 1.15 Plate DOL = 1.15); Is=1.0; Rough Cat B; Partially Exp.; Ce=1.0; Cs=1.00; Ct=1.10
 - 4) Provide adequate drainage to prevent water ponding.
 - 5) Gable requires continuous bottom chord bearing.
 - 6) Truss to be fully sheathed from one face or securely braced against lateral movement (i.e. diagonal web).
 - 7) Gable studs spaced at 2-0-0 oc.
 - 8) This truss has been designed for a 10.0 psf bottom chord live load nonconcurrent with any other live loads.
 - 9) * This truss has been designed for a live load of 20.0psf on the bottom chord in all areas where a rectangle 3-6-0 tall by 2-0-0 wide will fit between the bottom chord and any other members.
 - 10) Provide mechanical connection (by others) of truss to bearing plate capable of withstanding 100 lb uplift at joint(s) except (jt=lb) D=1634, C=1634.
 - 11) This truss is designed in accordance with the 2018 International Building Code section 2306.1 and referenced standard ANSI/TPI 1.
 - 12) This truss has been designed for a total drag load of 240 plf. Lumber DOL=(1.33) Plate grip DOL=(1.33) Connect truss to resist drag loads along bottom chord from 0-0-0 to 1-5-12 for 240.0 plf.



September 12, 2024

WARNING - Verify design parameters and READ NOTES ON THIS AND INCLUDED MITEK REFERENCE PAGE MII-7473 rev. 6/30/2020 BEFORE USE.

Design valid for use only with MiTek® connectors. This design is based only upon parameters shown, and is for an individual building component, not a truss system. Before use, the building designer must verify the applicability of design parameters and properly incorporate this design into the overall building design. Bracing indicated is to prevent buckling of individual truss web and/or chord members only. Additional temporary and permanent bracing is always required for stability and to prevent collapse with possible personal injury and property damage. For general guidance regarding the fabrication, storage, delivery, erection and bracing of trusses and truss systems, see

Safety Information available from Truss Plate Institute, 2670 Crain Highway, Suite 203 Waldorf, MD 20601



240 Stirling Crescent
Bradford, ON. L3Z 4L5

Job	Truss	Truss Type	Qty	Ply	Buildings A-H	U1530864
N0653A	S6	BLOCKING SUPPORTED	98	1		

Alliance Truss (CA), Abbotsford, BC - V2S 7P6,

8.820 s Aug 30 2024 MiTek Industries, Inc. Thu Sep 12 02:48:23 2024 Page 1

ID:hFyjDMxrTsEK_kgkR0vWWVzFlgc-8_gOTeGv_9z3bLer5ynCBgDOoi0HMyf2BpSCQPyeVqs

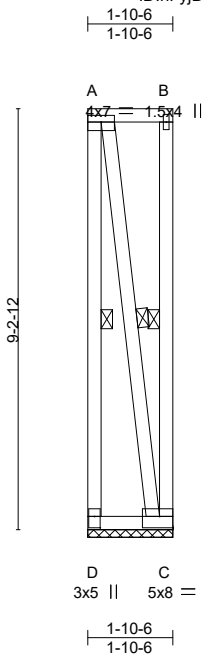

Scale = 1:50.5

Plate Offsets (X,Y)-- [A:Edge,0-1-12], [C:Edge,0-3-0], [D:0-3-0,0-1-8]

LOADING (psf)		SPACING-		CSI.		DEFL.				PLATES	GRIP	
TCLL	25.0	Plate Grip DOL	1.15	TC	0.81	Vert(LL)	n/a	-	n/a	999	MT20	197/144
(Roof Snow=25.0)		Lumber DOL	1.15	BC	0.07	Vert(CT)	n/a	-	n/a	999		
TCDL	12.0	Rep Stress Incr	YES	WB	0.83	Horz(CT)	0.00	C	n/a	n/a		
BCLL	0.0 *	Code IBC2018/TPI2014		Matrix-P							Weight: 34 lb	FT = 20%
BCDL	10.0											

LUMBER-

TOP CHORD 2x4 SPF No.2
 BOT CHORD 2x4 SPF No.2
 WEBS 2x4 SPF No.2

BRACING-

TOP CHORD Structural wood sheathing directly applied or 1-10-6 oc purlins, except end verticals.
 BOT CHORD Rigid ceiling directly applied or 6-0-0 oc bracing.
 WEBS 1 Row at midpt A-D, B-C, A-C

REACTIONS.

(size) D=1-10-6, C=1-10-6
 Max Uplift D=-2155(LC 23), C=-2155(LC 24)
 Max Grav D=2180(LC 44), C=2180(LC 43)

FORCES. (lb) - Max. Comp./Max. Ten. - All forces 250 (lb) or less except when shown.

TOP CHORD A-D=-2164/2163, A-B=-340/340
 BOT CHORD C-D=-340/340
 WEBS A-C=-2178/2178

NOTES-

- 1) Wind: ASCE 7-16; Vult=115mph (3-second gust) Vasd=91mph; TCDL=4.2psf; BCDL=5.0psf; h=30ft; Ke=1.00; Cat. II; Exp B; Enclosed; MWFRS (envelope) gable end zone; Lumber DOL=1.33 plate grip DOL=1.33
- 2) TCLL: ASCE 7-16; Pf=25.0 psf (Lum DOL = 1.15 Plate DOL = 1.15); Is=1.0; Rough Cat B; Partially Exp.; Ce=1.0; Cs=1.00; Ct=1.10
- 3) Provide adequate drainage to prevent water ponding.
- 4) Gable requires continuous bottom chord bearing.
- 5) This truss has been designed for a 10.0 psf bottom chord live load nonconcurrent with any other live loads.
- 6) * This truss has been designed for a live load of 20.0psf on the bottom chord in all areas where a rectangle 3-6-0 tall by 2-0-0 wide will fit between the bottom chord and any other members.
- 7) Provide mechanical connection (by others) of truss to bearing plate capable of withstanding 100 lb uplift at joint(s) except (jt=lb) D=2155, C=2155.
- 8) This truss is designed in accordance with the 2018 International Building Code section 2306.1 and referenced standard ANSI/TPI 1.
- 9) This truss has been designed for a total drag load of 240 plf. Lumber DOL=(1.33) Plate grip DOL=(1.33) Connect truss to resist drag loads along bottom chord from 0-0-0 to 1-10-6 for 240.0 plf.



September 12, 2024

WARNING - Verify design parameters and READ NOTES ON THIS AND INCLUDED MITEK REFERENCE PAGE MII-7473 rev. 6/30/2020 BEFORE USE.

Design valid for use only with MiTek® connectors. This design is based only upon parameters shown, and is for an individual building component, not a truss system. Before use, the building designer must verify the applicability of design parameters and properly incorporate this design into the overall building design. Bracing indicated is to prevent buckling of individual truss web and/or chord members only. Additional temporary and permanent bracing is always required for stability and to prevent collapse with possible personal injury and property damage. For general guidance regarding the fabrication, storage, delivery, erection and bracing of trusses and truss systems, see

Safety Information available from Truss Plate Institute, 2670 Crain Highway, Suite 203 Waldorf, MD 20601

ANSI/TPI1 Quality Criteria, DSB-89 and BCSI Building Component



240 Stirling Crescent
 Bradford, ON. L3Z 4L5

Job	Truss	Truss Type	Qty	Ply	Buildings A-H	U1530865
N0653A	S7	BLOCKING SUPPORTED	99	1		

Alliance Truss (CA), Abbotsford, BC - V2S 7P6,

8.820 s Aug 30 2024 MiTek Industries, Inc. Thu Sep 12 02:48:24 2024 Page 1

ID:hFyjDMxrTsEK_kgkR0vWWVzFfgc-cAEHh_HXIS5wCVD2fglSjulYE6MW5OcBQTcmyryeVqr

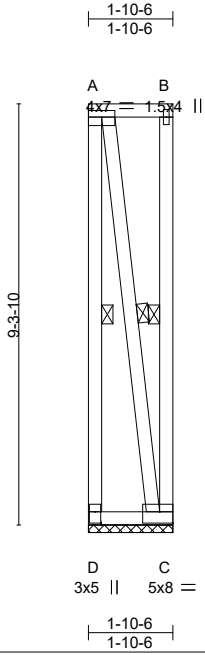

Scale = 1:50.9

Plate Offsets (X,Y)-- [A:Edge,0-1-12], [C:Edge,0-3-0], [D:0-3-0,0-1-8]

LOADING (psf)		SPACING-		CSI.		DEFL.				PLATES	GRIP	
TCLL	25.0	Plate Grip DOL	1.15	TC	0.83	Vert(LL)	n/a	-	n/a	999	MT20	197/144
(Roof Snow=25.0)		Lumber DOL	1.15	BC	0.07	Vert(CT)	n/a	-	n/a	999		
TCDL	12.0	Rep Stress Incr	YES	WB	0.85	Horz(CT)	0.00	C	n/a	n/a		
BCLL	0.0 *	Code IBC2018/TPI2014		Matrix-P							Weight: 34 lb	FT = 20%
BCDL	10.0											

LUMBER-

TOP CHORD 2x4 SPF No.2
 BOT CHORD 2x4 SPF No.2
 WEBS 2x4 SPF No.2

BRACING-

TOP CHORD Structural wood sheathing directly applied or 1-10-6 oc purlins, except end verticals.
 BOT CHORD Rigid ceiling directly applied or 6-0-0 oc bracing.
 WEBS 1 Row at midpt A-D, B-C, A-C

REACTIONS.

(size) D=1-10-6, C=1-10-6
 Max Uplift D=-2171(LC 23), C=-2171(LC 24)
 Max Grav D=2197(LC 44), C=2197(LC 43)

FORCES. (lb) - Max. Comp./Max. Ten. - All forces 250 (lb) or less except when shown.

TOP CHORD A-D=-2181/2179, A-B=-340/340
 BOT CHORD C-D=-340/340
 WEBS A-C=-2195/2195

NOTES-

- 1) Wind: ASCE 7-16; Vult=115mph (3-second gust) Vasd=91mph; TCDL=4.2psf; BCDL=5.0psf; h=30ft; Ke=1.00; Cat. II; Exp B; Enclosed; MWFRS (envelope) gable end zone; Lumber DOL=1.33 plate grip DOL=1.33
- 2) TCLL: ASCE 7-16; Pf=25.0 psf (Lum DOL = 1.15 Plate DOL = 1.15); Is=1.0; Rough Cat B; Partially Exp.; Ce=1.0; Cs=1.00; Ct=1.10
- 3) Provide adequate drainage to prevent water ponding.
- 4) Gable requires continuous bottom chord bearing.
- 5) This truss has been designed for a 10.0 psf bottom chord live load nonconcurrent with any other live loads.
- 6) * This truss has been designed for a live load of 20.0psf on the bottom chord in all areas where a rectangle 3-6-0 tall by 2-0-0 wide will fit between the bottom chord and any other members.
- 7) Provide mechanical connection (by others) of truss to bearing plate capable of withstanding 100 lb uplift at joint(s) except (jt=lb) D=2171, C=2171.
- 8) This truss is designed in accordance with the 2018 International Building Code section 2306.1 and referenced standard ANSI/TPI 1.
- 9) This truss has been designed for a total drag load of 240 plf. Lumber DOL=(1.33) Plate grip DOL=(1.33) Connect truss to resist drag loads along bottom chord from 0-0-0 to 1-10-6 for 240.0 plf.



September 12, 2024

WARNING - Verify design parameters and READ NOTES ON THIS AND INCLUDED MITEK REFERENCE PAGE MII-7473 rev. 6/30/2020 BEFORE USE.

Design valid for use only with MiTek® connectors. This design is based only upon parameters shown, and is for an individual building component, not a truss system. Before use, the building designer must verify the applicability of design parameters and properly incorporate this design into the overall building design. Bracing indicated is to prevent buckling of individual truss web and/or chord members only. Additional temporary and permanent bracing is always required for stability and to prevent collapse with possible personal injury and property damage. For general guidance regarding the fabrication, storage, delivery, erection and bracing of trusses and truss systems, see

Safety Information available from Truss Plate Institute, 2670 Crain Highway, Suite 203 Waldorf, MD 20601

ANSI/TPI1 Quality Criteria, DSB-89 and BCSI Building Component



240 Stirling Crescent
 Bradford, ON. L3Z 4L5

Job	Truss	Truss Type	Qty	Ply	Buildings A-H	U1530796
N0653A	S8	BLOCKING SUPPORTED	4	1		

Alliance Truss (CA), Abbotsford, BC - V2S 7P6,

8.630 s Jul 12 2024 MiTek Industries, Inc. Thu Sep 12 02:47:45 2024 Page 1

ID:hFyjDMxrTsEK_kgkR0vWWVzFgC-RfC?PsB70Hq3NSgPqnL8w3ulTXbGKWrCDoi7J4zJC?f

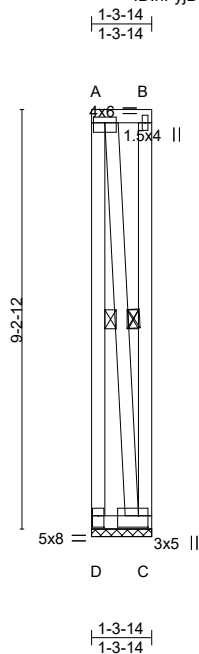

Scale = 1:50.7

Plate Offsets (X,Y)-- [A:0-3-0,0-1-8], [C:0-2-8,0-3-0], [D:0-3-0,0-1-8]

LOADING (psf)	SPACING-	CSI.	DEFL.	in (loc)	l/defl	L/d	PLATES	GRIP
TCLL 25.0 (Roof Snow=25.0)	2-0-0 Plate Grip DOL 1.15	TC 0.81	Vert(LL)	n/a	-	n/a	MT20	197/144
TCDL 12.0	Lumber DOL 1.15	BC 0.04	Vert(CT)	n/a	-	n/a		
BCLL 0.0 *	Rep Stress Incr YES	WB 0.81	Horz(CT)	0.00	C	n/a		
BCDL 10.0	Code IBC2018/TPI2014	Matrix-P					Weight: 33 lb	FT = 20%

LUMBER-

TOP CHORD 2x4 SPF No.2
 BOT CHORD 2x4 SPF No.2
 WEBS 2x4 SPF No.2

BRACING-

TOP CHORD Structural wood sheathing directly applied or 1-3-14 oc purlins, except end verticals.
 BOT CHORD Rigid ceiling directly applied or 6-0-0 oc bracing.
 WEBS 1 Row at midpt A-D, B-C, A-C

REACTIONS.

(size) D=1-3-14, C=1-3-14
 Max Uplift D=-2152(LC 23), C=-2152(LC 24)
 Max Grav D=2168(LC 44), C=2168(LC 43)

FORCES. (lb) - Max. Comp./Max. Ten. - All forces 250 (lb) or less except when shown.

TOP CHORD A-D=-2158/2157
 WEBS A-C=-2160/2160

NOTES-

- 1) Wind: ASCE 7-16; Vult=115mph (3-second gust) Vasd=91mph; TCDL=4.2psf; BCDL=5.0psf; h=30ft; Ke=1.00; Cat. II; Exp B; Enclosed; MWFRS (envelope) gable end zone; Lumber DOL=1.33 plate grip DOL=1.33
- 2) TCLL: ASCE 7-16; Pf=25.0 psf (Lum DOL=1.15 Plate DOL=1.15); Is=1.0; Rough Cat B; Partially Exp.; Ce=1.0; Cs=1.00; Ct=1.10
- 3) Provide adequate drainage to prevent water ponding.
- 4) Gable requires continuous bottom chord bearing.
- 5) This truss has been designed for a 10.0 psf bottom chord live load nonconcurrent with any other live loads.
- 6) * This truss has been designed for a live load of 20.0psf on the bottom chord in all areas where a rectangle 3-6-0 tall by 2-0-0 wide will fit between the bottom chord and any other members.
- 7) Provide mechanical connection (by others) of truss to bearing plate capable of withstanding 100 lb uplift at joint(s) except (jt=lb) D=2152, C=2152.
- 8) This truss is designed in accordance with the 2018 International Building Code section 2306.1 and referenced standard ANSI/TPI 1.
- 9) This truss has been designed for a total drag load of 240 plf. Lumber DOL=(1.33) Plate grip DOL=(1.33) Connect truss to resist drag loads along bottom chord from 0-0-0 to 1-3-14 for 240.0 plf.



September 12, 2024

WARNING - Verify design parameters and READ NOTES ON THIS AND INCLUDED MITEK REFERENCE PAGE MII-7473 rev. 6/30/2020 BEFORE USE.

Design valid for use only with MiTek® connectors. This design is based only upon parameters shown, and is for an individual building component, not a truss system. Before use, the building designer must verify the applicability of design parameters and properly incorporate this design into the overall building design. Bracing indicated is to prevent buckling of individual truss web and/or chord members only. Additional temporary and permanent bracing is always required for stability and to prevent collapse with possible personal injury and property damage. For general guidance regarding the fabrication, storage, delivery, erection and bracing of trusses and truss systems, see

Safety Information available from Truss Plate Institute, 2670 Crain Highway, Suite 203 Waldorf, MD 20601

ANSI/TPI1 Quality Criteria, DSB-89 and BCSI Building Component



240 Stirling Crescent
 Bradford, ON. L3Z 4L5

Job	Truss	Truss Type	Qty	Ply	Buildings A-H	U1530797
N0653A	S9	BLOCKING SUPPORTED	4	1		

Alliance Truss (CA), Abbotsford, BC - V2S 7P6,

8.630 s Jul 12 2024 MiTek Industries, Inc. Thu Sep 12 02:47:46 2024 Page 1

ID:hFyjDMxrTsEK_kgkR0vWWVzFgC-RfC?PsB70Hq3NSgPqnL8w3ulTXbGKWrCDoi7J4zJC?f

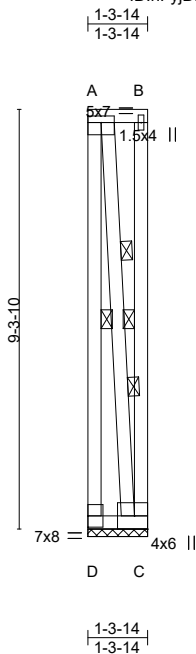

Scale = 1:51.1

Plate Offsets (X,Y)-- [A:Edge,0-1-12]

LOADING (psf)	SPACING-	CSI.	DEFL.	in (loc)	l/defl	L/d	PLATES	GRIP
TCLL 25.0 (Roof Snow=25.0)	2-0-0 Plate Grip DOL 1.15	TC 0.98	Vert(LL)	n/a	-	n/a	MT20	197/144
TCDL 12.0	Lumber DOL 1.15	BC 0.08	Vert(CT)	n/a	-	n/a		
BCLL 0.0 *	Rep Stress Incr YES	WB 0.96	Horz(CT)	-0.00	C	n/a		
BCDL 10.0	Code IBC2018/TPI2014	Matrix-P					Weight: 33 lb	FT = 20%

LUMBER-

TOP CHORD 2x4 SPF No.2
 BOT CHORD 2x4 SPF No.2
 WEBS 2x4 SPF 2100F 1.8E *Except*
 A-C: 2x4 SPF No.2

BRACING-

TOP CHORD Structural wood sheathing directly applied or 1-3-14 oc purlins, except end verticals.
 BOT CHORD Rigid ceiling directly applied or 6-0-0 oc bracing.
 WEBS 1 Row at midpt A-D, B-C
 2 Rows at 1/3 pts A-C

REACTIONS.

(size) D=1-3-14, C=1-3-14
 Max Horz D=-255(LC 4)
 Max Uplift D=-3281(LC 24), C=-3281(LC 27)
 Max Grav D=3287(LC 31), C=3287(LC 28)

FORCES. (lb) - Max. Comp./Max. Ten. - All forces 250 (lb) or less except when shown.

TOP CHORD A-D=-3276/3286, A-B=-317/295
 BOT CHORD C-D=-445/422
 WEBS A-C=-3297/3297

NOTES-

- 1) Wind: ASCE 7-16; Vult=115mph (3-second gust) Vasd=91mph; TCDL=4.2psf; BCDL=5.0psf; h=30ft; Ke=1.00; Cat. II; Exp B; Enclosed; MWFRS (envelope) gable end zone; cantilever left and right exposed; end vertical left and right exposed; Lumber DOL=1.33 plate grip DOL=1.33
- 2) Truss designed for wind loads in the plane of the truss only. For studs exposed to wind (normal to the face), see Standard Industry Gable End Details as applicable, or consult qualified building designer as per ANSI/TPI 1.
- 3) TCLL: ASCE 7-16; Pf=25.0 psf (Lum DOL=1.15 Plate DOL=1.15); Is=1.0; Rough Cat B; Partially Exp.; Ce=1.0; Cs=1.00; Ct=1.10
- 4) Provide adequate drainage to prevent water ponding.
- 5) Gable requires continuous bottom chord bearing.
- 6) Truss to be fully sheathed from one face or securely braced against lateral movement (i.e. diagonal web).
- 7) Gable studs spaced at 2-0-0 oc.
- 8) This truss has been designed for a 10.0 psf bottom chord live load nonconcurrent with any other live loads.
- 9) * This truss has been designed for a live load of 20.0psf on the bottom chord in all areas where a rectangle 3-6-0 tall by 2-0-0 wide will fit between the bottom chord and any other members.
- 10) Provide mechanical connection (by others) of truss to bearing plate capable of withstanding 100 lb uplift at joint(s) except (jt=lb) D=3281, C=3281.
- 11) This truss is designed in accordance with the 2018 International Building Code section 2306.1 and referenced standard ANSI/TPI 1.
- 12) This truss has been designed for a total drag load of 240 pif. Lumber DOL=(1.33) Plate grip DOL=(1.33) Connect truss to resist drag loads along bottom chord from 0-0-0 to 1-3-14 for 240.0 pif.



September 12, 2024

WARNING - Verify design parameters and READ NOTES ON THIS AND INCLUDED MITEK REFERENCE PAGE MII-7473 rev. 6/30/2020 BEFORE USE.

Design valid for use only with MiTek® connectors. This design is based only upon parameters shown, and is for an individual building component, not a truss system. Before use, the building designer must verify the applicability of design parameters and properly incorporate this design into the overall building design. Bracing indicated is to prevent buckling of individual truss web and/or chord members only. Additional temporary and permanent bracing is always required for stability and to prevent collapse with possible personal injury and property damage. For general guidance regarding the fabrication, storage, delivery, erection and bracing of trusses and truss systems, see

Safety Information available from Truss Plate Institute, 2670 Crain Highway, Suite 203 Waldorf, MD 20601

ANSI/TPI1 Quality Criteria, DSB-89 and BCSI Building Component



240 Stirling Crescent
 Bradford, ON. L3Z 4L5

Job	Truss	Truss Type	Qty	Ply	Buildings A-H	U1530798
N0653A	S10	BLOCKING SUPPORTED	1	1		

Alliance Truss (CA), Abbotsford, BC - V2S 7P6,

8.630 s Jul 12 2024 MiTek Industries, Inc. Thu Sep 12 02:47:42 2024 Page 1

ID:hFyjDMxrTsEK_kgkR0vWWVzFgC-RfC?PsB70Hq3NSgPqnL8w3ulTXbGKWrCDoi7J4zJC?f

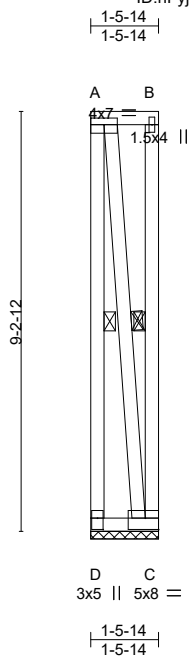

Scale = 1:50.6

Plate Offsets (X,Y)-- [A:Edge,0-1-12], [C:Edge,0-3-0], [D:0-3-0,0-1-8]

LOADING (psf)		SPACING-		CSI.		DEFL.				PLATES	GRIP	
TCLL	25.0	Plate Grip DOL	1.15	TC	0.81	Vert(LL)	n/a	-	n/a	999	MT20	197/144
(Roof Snow=25.0)		Lumber DOL	1.15	BC	0.05	Vert(CT)	n/a	-	n/a	999		
TCDL	12.0	Rep Stress Incr	YES	WB	0.82	Horz(CT)	0.00	C	n/a	n/a		
BCLL	0.0 *	Code IBC2018/TPI2014		Matrix-P							Weight: 33 lb	FT = 20%
BCDL	10.0											

LUMBER-

TOP CHORD 2x4 SPF No.2
 BOT CHORD 2x4 SPF No.2
 WEBS 2x4 SPF No.2

BRACING-

TOP CHORD Structural wood sheathing directly applied or 1-5-14 oc purlins, except end verticals.
 BOT CHORD Rigid ceiling directly applied or 6-0-0 oc bracing.
 WEBS 1 Row at midpt A-D, B-C, A-C

REACTIONS.

(size) D=1-5-14, C=1-5-14
 Max Uplift D=-2153(LC 23), C=-2153(LC 24)
 Max Grav D=2172(LC 44), C=2172(LC 43)

FORCES. (lb) - Max. Comp./Max. Ten. - All forces 250 (lb) or less except when shown.

TOP CHORD A-D=-2160/2159, A-B=-259/259
 BOT CHORD C-D=-259/259
 WEBS A-C=-2165/2165

NOTES-

- Wind: ASCE 7-16; Vult=115mph (3-second gust) Vasd=91mph; TCDL=4.2psf; BCDL=5.0psf; h=30ft; Ke=1.00; Cat. II; Exp B; Enclosed; MWFRS (envelope) gable end zone; Lumber DOL=1.33 plate grip DOL=1.33
- TCLL: ASCE 7-16; Pf=25.0 psf (Lum DOL=1.15 Plate DOL=1.15); Is=1.0; Rough Cat B; Partially Exp.; Ce=1.0; Cs=1.00; Ct=1.10
- Provide adequate drainage to prevent water ponding.
- Gable requires continuous bottom chord bearing.
- This truss has been designed for a 10.0 psf bottom chord live load nonconcurrent with any other live loads.
- * This truss has been designed for a live load of 20.0psf on the bottom chord in all areas where a rectangle 3-6-0 tall by 2-0-0 wide will fit between the bottom chord and any other members.
- Provide mechanical connection (by others) of truss to bearing plate capable of withstanding 100 lb uplift at joint(s) except (jt=lb) D=2153, C=2153.
- This truss is designed in accordance with the 2018 International Building Code section 2306.1 and referenced standard ANSI/TPI 1.
- This truss has been designed for a total drag load of 240 plf. Lumber DOL=(1.33) Plate grip DOL=(1.33) Connect truss to resist drag loads along bottom chord from 0-0-0 to 1-5-14 for 240.0 plf.



September 12, 2024

WARNING - Verify design parameters and READ NOTES ON THIS AND INCLUDED MITEK REFERENCE PAGE MII-7473 rev. 6/30/2020 BEFORE USE.

Design valid for use only with MiTek® connectors. This design is based only upon parameters shown, and is for an individual building component, not a truss system. Before use, the building designer must verify the applicability of design parameters and properly incorporate this design into the overall building design. Bracing indicated is to prevent buckling of individual truss web and/or chord members only. Additional temporary and permanent bracing is always required for stability and to prevent collapse with possible personal injury and property damage. For general guidance regarding the fabrication, storage, delivery, erection and bracing of trusses and truss systems, see

Safety Information available from Truss Plate Institute, 2670 Crain Highway, Suite 203 Waldorf, MD 20601

ANSI/TPI1 Quality Criteria, DSB-89 and BCSI Building Component



240 Stirling Crescent
 Bradford, ON. L3Z 4L5

Job	Truss	Truss Type	Qty	Ply	Buildings A-H	U1530799
N0653A	S11	BLOCKING SUPPORTED	1	1		

Alliance Truss (CA), Abbotsford, BC - V2S 7P6,

8.630 s Jul 12 2024 MiTek Industries, Inc. Thu Sep 12 02:47:43 2024 Page 1

ID:hFyjDMxrTsEK_kgkR0vWWVzFgC-RfC?PsB70Hq3NSgPqnL8w3ulTXbGKWrCDoi7J4zJC?f

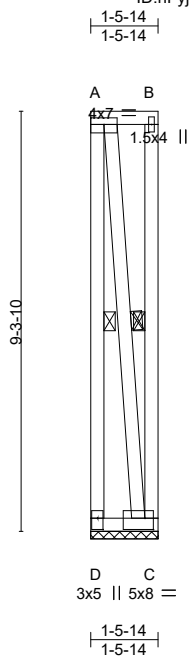

Scale = 1:51.0

Plate Offsets (X,Y)-- [A:Edge,0-1-12], [C:0-2-4,0-3-0], [D:0-3-0,0-1-8]

LOADING (psf)		SPACING-		CSI.		DEFL.				PLATES	GRIP	
TCLL	25.0	Plate Grip DOL	1.15	TC	0.83	Vert(LL)	n/a	-	n/a	999	MT20	197/144
(Roof Snow=25.0)		Lumber DOL	1.15	BC	0.05	Vert(CT)	n/a	-	n/a	999		
TCDL	12.0	Rep Stress Incr	YES	WB	0.84	Horz(CT)	0.00	C	n/a	n/a		
BCLL	0.0 *	Code IBC2018/TPI2014		Matrix-P							Weight: 33 lb	FT = 20%
BCDL	10.0											

LUMBER-

TOP CHORD 2x4 SPF No.2
 BOT CHORD 2x4 SPF No.2
 WEBS 2x4 SPF No.2

REACTIONS.

(size) D=1-5-14, C=1-5-14
 Max Uplift D=-2169(LC 23), C=-2169(LC 24)
 Max Grav D=2188(LC 44), C=2188(LC 43)

FORCES. (lb) - Max. Comp./Max. Ten. - All forces 250 (lb) or less except when shown.

TOP CHORD A-D=-2176/2175, A-B=-259/259
 BOT CHORD C-D=-259/259
 WEBS A-C=-2181/2181

NOTES-

- Wind: ASCE 7-16; Vult=115mph (3-second gust) Vasd=91mph; TCDL=4.2psf; BCDL=5.0psf; h=30ft; Ke=1.00; Cat. II; Exp B; Enclosed; MWFRS (envelope) gable end zone; Lumber DOL=1.33 plate grip DOL=1.33
- TCLL: ASCE 7-16; Pf=25.0 psf (Lum DOL=1.15 Plate DOL=1.15); Is=1.0; Rough Cat B; Partially Exp.; Ce=1.0; Cs=1.00; Ct=1.10
- Provide adequate drainage to prevent water ponding.
- Gable requires continuous bottom chord bearing.
- This truss has been designed for a 10.0 psf bottom chord live load nonconcurrent with any other live loads.
- * This truss has been designed for a live load of 20.0psf on the bottom chord in all areas where a rectangle 3-6-0 tall by 2-0-0 wide will fit between the bottom chord and any other members.
- Provide mechanical connection (by others) of truss to bearing plate capable of withstanding 100 lb uplift at joint(s) except (jt=lb) D=2169, C=2169.
- This truss is designed in accordance with the 2018 International Building Code section 2306.1 and referenced standard ANSI/TPI 1.
- This truss has been designed for a total drag load of 240 plf. Lumber DOL=(1.33) Plate grip DOL=(1.33) Connect truss to resist drag loads along bottom chord from 0-0-0 to 1-5-14 for 240.0 plf.



September 12, 2024

WARNING - Verify design parameters and READ NOTES ON THIS AND INCLUDED MITEK REFERENCE PAGE MII-7473 rev. 6/30/2020 BEFORE USE.

Design valid for use only with MiTek® connectors. This design is based only upon parameters shown, and is for an individual building component, not a truss system. Before use, the building designer must verify the applicability of design parameters and properly incorporate this design into the overall building design. Bracing indicated is to prevent buckling of individual truss web and/or chord members only. Additional temporary and permanent bracing is always required for stability and to prevent collapse with possible personal injury and property damage. For general guidance regarding the fabrication, storage, delivery, erection and bracing of trusses and truss systems, see

Safety Information available from Truss Plate Institute, 2670 Crain Highway, Suite 203 Waldorf, MD 20601

ANSI/TPI1 Quality Criteria, DSB-89 and BCSI Building Component



240 Stirling Crescent
 Bradford, ON. L3Z 4L5

Job	Truss	Truss Type	Qty	Ply	Buildings A-H
N0653A	S12	BLOCKING SUPPORTED	232	1	U1530800

Alliance Truss (CA), Abbotsford, BC - V2S 7P6,

8.630 s Jul 12 2024 MiTek Industries, Inc. Thu Sep 12 02:47:43 2024 Page 1

ID:hFyjDMxrTsEK_kgkR0vWWVzFgC-RfC?PsB70Hq3NSgPqnL8w3ulTXbGKWrCDoi7J4zJC?f

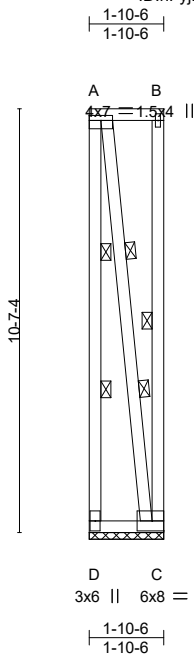

Scale = 1:57.7

Plate Offsets (X,Y)-- [A:Edge,0-1-8]

LOADING (psf)	SPACING-	CSI.	DEFL.	in (loc)	l/defl	L/d	PLATES	GRIP
TCLL 25.0 (Roof Snow=25.0)	2-0-0 Plate Grip DOL 1.15 Lumber DOL 1.15	TC 0.93 BC 0.07 WB 0.94 Matrix-P	Vert(LL) Vert(CT) Horz(CT)	n/a n/a 0.00	- - C	n/a n/a n/a	999 999	MT20 197/144
TCDL 12.0	Rep Stress Incr YES Code IBC2018/TPI2014						Weight: 39 lb	FT = 20%
BCLL 0.0 *								
BCDL 10.0								

LUMBER-

TOP CHORD 2x4 SPF No.2
 BOT CHORD 2x4 SPF No.2
 WEBS 2x4 SPF No.2

BRACING-

TOP CHORD Structural wood sheathing directly applied or 1-10-6 oc purlins, except end verticals.
 BOT CHORD Rigid ceiling directly applied or 6-0-0 oc bracing.
 WEBS 1 Row at midpt B-C
 2 Rows at 1/3 pts A-D, A-C

REACTIONS.

(size) D=1-10-6, C=1-10-6
 Max Uplift D=-2485(LC 23), C=-2485(LC 24)
 Max Grav D=2510(LC 44), C=2510(LC 43)

FORCES. (lb) - Max. Comp./Max. Ten. - All forces 250 (lb) or less except when shown.

TOP CHORD A-D=-2494/2493, A-B=-340/340
 BOT CHORD C-D=-340/340
 WEBS A-C=-2504/2504

NOTES-

- 1) Wind: ASCE 7-16; Vult=115mph (3-second gust) Vasd=91mph; TCDL=4.2psf; BCDL=5.0psf; h=30ft; Ke=1.00; Cat. II; Exp B; Enclosed; MWFRS (envelope) gable end zone; Lumber DOL=1.33 plate grip DOL=1.33
- 2) TCLL: ASCE 7-16; Pf=25.0 psf (Lum DOL=1.15 Plate DOL=1.15); Is=1.0; Rough Cat B; Partially Exp.; Ce=1.0; Cs=1.00; Ct=1.10
- 3) Provide adequate drainage to prevent water ponding.
- 4) Gable requires continuous bottom chord bearing.
- 5) This truss has been designed for a 10.0 psf bottom chord live load nonconcurrent with any other live loads.
- 6) * This truss has been designed for a live load of 20.0psf on the bottom chord in all areas where a rectangle 3-6-0 tall by 2-0-0 wide will fit between the bottom chord and any other members.
- 7) Provide mechanical connection (by others) of truss to bearing plate capable of withstanding 100 lb uplift at joint(s) except (jt=lb) D=2485, C=2485.
- 8) This truss is designed in accordance with the 2018 International Building Code section 2306.1 and referenced standard ANSI/TPI 1.
- 9) This truss has been designed for a total drag load of 240 plf. Lumber DOL=(1.33) Plate grip DOL=(1.33) Connect truss to resist drag loads along bottom chord from 0-0-0 to 1-10-6 for 240.0 plf.



September 12, 2024

WARNING - Verify design parameters and READ NOTES ON THIS AND INCLUDED MITEK REFERENCE PAGE MII-7473 rev. 6/30/2020 BEFORE USE.

Design valid for use only with MiTek® connectors. This design is based only upon parameters shown, and is for an individual building component, not a truss system. Before use, the building designer must verify the applicability of design parameters and properly incorporate this design into the overall building design. Bracing indicated is to prevent buckling of individual truss web and/or chord members only. Additional temporary and permanent bracing is always required for stability and to prevent collapse with possible personal injury and property damage. For general guidance regarding the fabrication, storage, delivery, erection and bracing of trusses and truss systems, see

Safety Information available from Truss Plate Institute, 2670 Crain Highway, Suite 203 Waldorf, MD 20601



240 Stirling Crescent
 Bradford, ON. L3Z 4L5

Job	Truss	Truss Type	Qty	Ply	Buildings A-H	U1530801
N0653A	S13	BLOCKING SUPPORTED	6	1		

Alliance Truss (CA), Abbotsford, BC - V2S 7P6,

8.630 s Jul 12 2024 MiTek Industries, Inc. Thu Sep 12 02:47:44 2024 Page 1

ID:hFyjDMxrTsEK_kgkR0vWWVzFfgc-RfC?PsB70Hq3NSgPqnL8w3ulTXbGKWrCDoi7J4zJC?f

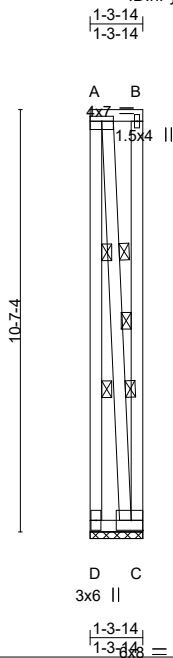

Scale = 1:57.9

Plate Offsets (X,Y)-- [A:Edge,0-1-8]

LOADING (psf)	SPACING-	CSI.	DEFL.	in (loc)	l/defl	L/d	PLATES	GRIP
TCLL 25.0 (Roof Snow=25.0)	2-0-0 Plate Grip DOL 1.15 Lumber DOL 1.15	TC 0.92 BC 0.04 WB 0.93 Matrix-P	Vert(LL) Vert(CT) Horz(CT)	n/a n/a 0.00	- - C	n/a n/a n/a	MT20	197/144
TCDL 12.0	Rep Stress Incr YES Code IBC2018/TPI2014						Weight: 37 lb	FT = 20%
BCLL 0.0 *								
BCDL 10.0								

LUMBER-

TOP CHORD 2x4 SPF No.2
 BOT CHORD 2x4 SPF No.2
 WEBS 2x4 SPF No.2

BRACING-

TOP CHORD Structural wood sheathing directly applied or 1-3-14 oc purlins, except end verticals.
 BOT CHORD Rigid ceiling directly applied or 6-0-0 oc bracing.
 WEBS 1 Row at midpt B-C
 2 Rows at 1/3 pts A-D, A-C

REACTIONS.

(size) D=1-3-14, C=1-3-14
 Max Uplift D=-2482(LC 23), C=-2482(LC 24)
 Max Grav D=2498(LC 44), C=2498(LC 43)

FORCES. (lb) - Max. Comp./Max. Ten. - All forces 250 (lb) or less except when shown.

TOP CHORD A-D=-2488/2487
 WEBS A-C=-2488/2488

NOTES-

- 1) Wind: ASCE 7-16; Vult=115mph (3-second gust) Vasd=91mph; TCDL=4.2psf; BCDL=5.0psf; h=30ft; Ke=1.00; Cat. II; Exp B; Enclosed; MWFRS (envelope) gable end zone; Lumber DOL=1.33 plate grip DOL=1.33
- 2) Truss designed for wind loads in the plane of the truss only. For studs exposed to wind (normal to the face), see Standard Industry Gable End Details as applicable, or consult qualified building designer as per ANSI/TPI 1.
- 3) TCLL: ASCE 7-16; Pf=25.0 psf (Lum DOL=1.15 Plate DOL=1.15); Is=1.0; Rough Cat B; Partially Exp.; Ce=1.0; Cs=1.00; Ct=1.10
- 4) Provide adequate drainage to prevent water ponding.
- 5) Gable requires continuous bottom chord bearing.
- 6) Truss to be fully sheathed from one face or securely braced against lateral movement (i.e. diagonal web).
- 7) Gable studs spaced at 2-0-0 oc.
- 8) This truss has been designed for a 10.0 psf bottom chord live load nonconcurrent with any other live loads.
- 9) * This truss has been designed for a live load of 20.0psf on the bottom chord in all areas where a rectangle 3-6-0 tall by 2-0-0 wide will fit between the bottom chord and any other members.
- 10) Provide mechanical connection (by others) of truss to bearing plate capable of withstanding 100 lb uplift at joint(s) except (jt=lb) D=2482, C=2482.
- 11) This truss is designed in accordance with the 2018 International Building Code section 2306.1 and referenced standard ANSI/TPI 1.
- 12) This truss has been designed for a total drag load of 240 plf. Lumber DOL=(1.33) Plate grip DOL=(1.33) Connect truss to resist drag loads along bottom chord from 0-0-0 to 1-3-14 for 240.0 plf.



September 12, 2024

WARNING - Verify design parameters and READ NOTES ON THIS AND INCLUDED MITEK REFERENCE PAGE MII-7473 rev. 6/30/2020 BEFORE USE.

Design valid for use only with MiTek® connectors. This design is based only upon parameters shown, and is for an individual building component, not a truss system. Before use, the building designer must verify the applicability of design parameters and properly incorporate this design into the overall building design. Bracing indicated is to prevent buckling of individual truss web and/or chord members only. Additional temporary and permanent bracing is always required for stability and to prevent collapse with possible personal injury and property damage. For general guidance regarding the fabrication, storage, delivery, erection and bracing of trusses and truss systems, see

ANSI/TPI1 Quality Criteria, DSB-89 and BCSI Building Component

Safety Information available from Truss Plate Institute, 2670 Crain Highway, Suite 203 Waldorf, MD 20601



240 Stirling Crescent
 Bradford, ON. L3Z 4L5

Job	Truss	Truss Type	Qty	Ply	Buildings A-H	U1530802
N0653A	S14	BLOCKING SUPPORTED	36	1		

Alliance Truss (CA), Abbotsford, BC - V2S 7P6,

8.630 s Jul 12 2024 MiTek Industries, Inc. Thu Sep 12 02:47:45 2024 Page 1

ID:hFyjDMxrTsEK_kgkR0vWWVzFgC-RfC?PsB70Hq3NSgPqnL8w3ulTXbGKWrCDoi7J4zJC?f

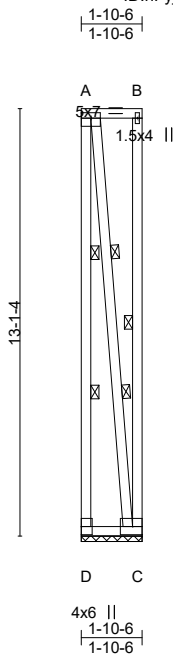

Scale = 1:70.6

Plate Offsets (X,Y)-- [A:Edge,0-2-0]

6x8 =

LOADING (psf)	SPACING-	CSI.	DEFL.	in (loc)	l/defl	L/d	PLATES	GRIP
TCLL 25.0 (Roof Snow=25.0)	2-0-0 Plate Grip DOL 1.15 Lumber DOL 1.15	TC 0.99 BC 0.07 WB 1.00 Matrix-P	Vert(LL) Vert(CT) Horz(CT)	n/a n/a 0.00	- - C	n/a n/a n/a	MT20	197/144
TCDL 12.0	Rep Stress Incr YES Code IBC2018/TPI2014						Weight: 47 lb	FT = 20%
BCLL 0.0 *								
BCDL 10.0								

LUMBER-

TOP CHORD 2x4 SPF No.2
 BOT CHORD 2x4 SPF No.2
 WEBS 2x4 SPF 2100F 1.8E

BRACING-

TOP CHORD Structural wood sheathing directly applied or 1-10-6 oc purlins, except end verticals.
 BOT CHORD Rigid ceiling directly applied or 6-0-0 oc bracing.
 WEBS 1 Row at midpt B-C
 2 Rows at 1/3 pts A-D, A-C

REACTIONS.

(size) D=1-10-6, C=1-10-6
 Max Uplift D=-3085(LC 23), C=-3085(LC 24)
 Max Grav D=3110(LC 44), C=3110(LC 43)

FORCES. (lb) - Max. Comp./Max. Ten. - All forces 250 (lb) or less except when shown.

TOP CHORD A-D=-3094/3093, A-B=-340/340
 BOT CHORD C-D=-340/340
 WEBS A-C=-3099/3099

NOTES-

- 1) Wind: ASCE 7-16; Vult=115mph (3-second gust) Vasd=91mph; TCDL=4.2psf; BCDL=5.0psf; h=30ft; Ke=1.00; Cat. II; Exp B; Enclosed; MWFRS (envelope) gable end zone; Lumber DOL=1.33 plate grip DOL=1.33
- 2) TCLL: ASCE 7-16; Pf=25.0 psf (Lum DOL=1.15 Plate DOL=1.15); Is=1.0; Rough Cat B; Partially Exp.; Ce=1.0; Cs=1.00; Ct=1.10
- 3) Provide adequate drainage to prevent water ponding.
- 4) Gable requires continuous bottom chord bearing.
- 5) This truss has been designed for a 10.0 psf bottom chord live load nonconcurrent with any other live loads.
- 6) * This truss has been designed for a live load of 20.0psf on the bottom chord in all areas where a rectangle 3-6-0 tall by 2-0-0 wide will fit between the bottom chord and any other members.
- 7) Provide mechanical connection (by others) of truss to bearing plate capable of withstanding 100 lb uplift at joint(s) except (jt=lb) D=3085, C=3085.
- 8) This truss is designed in accordance with the 2018 International Building Code section 2306.1 and referenced standard ANSI/TPI 1.
- 9) This truss has been designed for a total drag load of 240 plf. Lumber DOL=(1.33) Plate grip DOL=(1.33) Connect truss to resist drag loads along bottom chord from 0-0-0 to 1-10-6 for 240.0 plf.



September 12, 2024

WARNING - Verify design parameters and READ NOTES ON THIS AND INCLUDED MITEK REFERENCE PAGE MII-7473 rev. 6/30/2020 BEFORE USE.

Design valid for use only with MiTek® connectors. This design is based only upon parameters shown, and is for an individual building component, not a truss system. Before use, the building designer must verify the applicability of design parameters and properly incorporate this design into the overall building design. Bracing indicated is to prevent buckling of individual truss web and/or chord members only. Additional temporary and permanent bracing is always required for stability and to prevent collapse with possible personal injury and property damage. For general guidance regarding the fabrication, storage, delivery, erection and bracing of trusses and truss systems, see

Safety Information available from Truss Plate Institute, 2670 Crain Highway, Suite 203 Waldorf, MD 20601
ANSI/TPI1 Quality Criteria, DSB-89 and BCSI Building Component



240 Stirling Crescent
 Bradford, ON. L3Z 4L5

Job	Truss	Truss Type	Qty	Ply	Buildings A-H	U1530866
N0653A	S15	BLOCKING STRUCTURAL	2	1		

Alliance Truss (CA), Abbotsford, BC - V2S 7P6,

8.820 s Aug 30 2024 MiTek Industries, Inc. Thu Sep 12 02:48:18 2024 Page 1

ID:hFyjDMxrTsEK_kgkR0vWWWzFgic-o0tVQwCmAcKnUamulPB1UdWbGhKphrQJ2XIRkByeVqx
 1-7-0
 1-7-0

Scale = 1:47.4

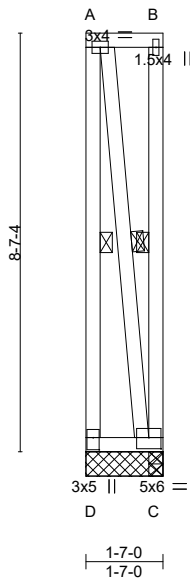

Plate Offsets (X,Y)-- [C:0-3-0,0-2-12], [D:0-3-0,0-1-8]

LOADING (psf)	SPACING-	CSI.	DEFL.	in (loc)	l/defl	L/d	PLATES	GRIP
TCLL 25.0 (Roof Snow=25.0)	2-0-0 Plate Grip DOL 1.15 Lumber DOL 1.15	TC 0.54 BC 0.03 WB 0.19 Matrix-P	Vert(LL) -0.00 Vert(CT) -0.00 Horz(CT) 0.00 Wind(LL) 0.00	D	>999	360	MT20	197/144
TCDL 12.0	Rep Stress Incr NO Code IBC2018/TPI2014			D	>999	240		
BCLL 0.0 *				C	n/a	n/a		
BCDL 10.0				D	****	240	Weight: 31 lb	FT = 20%

LUMBER-

TOP CHORD 2x4 SPF No.2
 BOT CHORD 2x4 SPF No.2
 WEBS 2x4 SPF No.2

BRACING-

TOP CHORD Structural wood sheathing directly applied or 1-7-0 oc purlins, except end verticals.
 BOT CHORD Rigid ceiling directly applied or 10-0-0 oc bracing.
 WEBS 1 Row at midpt A-D, B-C, A-C

REACTIONS.

(size) D=1-7-0, C=1-7-0, C=1-7-0
 Max Horz D=-175(LC 6)
 Max Uplift D=-548(LC 6), C=-435(LC 5)
 Max Grav D=419(LC 5), C=577(LC 6), C=61(LC 1)

FORCES. (lb) - Max. Comp./Max. Ten. - All forces 250 (lb) or less except when shown.

TOP CHORD A-D=-413/561
 WEBS A-C=-570/432

NOTES-

- 1) Wind: ASCE 7-16; Vult=115mph (3-second gust) Vasd=91mph; TCDL=4.2psf; BCDL=5.0psf; h=30ft; Ke=1.00; Cat. II; Exp B; Enclosed; MWFRS (envelope) gable end zone; cantilever left exposed ; end vertical left exposed; Lumber DOL=1.33 plate grip DOL=1.33
- 2) Truss designed for wind loads in the plane of the truss only. For studs exposed to wind (normal to the face), see Standard Industry Gable End Details as applicable, or consult qualified building designer as per ANSI/TPI 1.
- 3) TCLL: ASCE 7-16; Pf=25.0 psf (Lum DOL = 1.15 Plate DOL = 1.15); Is=1.0; Rough Cat B; Partially Exp.; Ce=1.0; Cs=1.00; Ct=1.10
- 4) Provide adequate drainage to prevent water ponding.
- 5) Gable studs spaced at 2-0-0 oc.
- 6) This truss has been designed for a 10.0 psf bottom chord live load nonconcurrent with any other live loads.
- 7) * This truss has been designed for a live load of 20.0psf on the bottom chord in all areas where a rectangle 3-6-0 tall by 2-0-0 wide will fit between the bottom chord and any other members.
- 8) Provide mechanical connection (by others) of truss to bearing plate capable of withstanding 100 lb uplift at joint(s) except (jt=lb) D=548, C=435.
- 9) This truss is designed in accordance with the 2018 International Building Code section 2306.1 and referenced standard ANSI/TPI 1.



September 12, 2024

WARNING - Verify design parameters and READ NOTES ON THIS AND INCLUDED MITEK REFERENCE PAGE MII-7473 rev. 6/30/2020 BEFORE USE.

Design valid for use only with MiTek® connectors. This design is based only upon parameters shown, and is for an individual building component, not a truss system. Before use, the building designer must verify the applicability of design parameters and properly incorporate this design into the overall building design. Bracing indicated is to prevent buckling of individual truss web and/or chord members only. Additional temporary and permanent bracing is always required for stability and to prevent collapse with possible personal injury and property damage. For general guidance regarding the fabrication, storage, delivery, erection and bracing of trusses and truss systems, see

Safety Information available from Truss Plate Institute, 2670 Crain Highway, Suite 203 Waldorf, MD 20601
ANSI/TPI1 Quality Criteria, DSB-89 and BCSI Building Component



240 Stirling Crescent
 Bradford, ON. L3Z 4L5

Job N0653A	Truss S16	Truss Type BLOCKING STRUCTURAL	Qty 9	Ply 1	Buildings A-H Job Reference (optional)	U1530867
---------------	--------------	-----------------------------------	----------	----------	---	----------

Alliance Truss (CA), Abbotsford, BC - V2S 7P6,

8.820 s Aug 30 2024 MiTek Industries, Inc. Thu Sep 12 02:48:18 2024 Page 1

ID:hFyjDMxrTsEK_kgkR0vWWVzFlgc-o0TVQwCmAcKnUamuIPB1UdWj0hKrhMJ2XIRkByeVqx

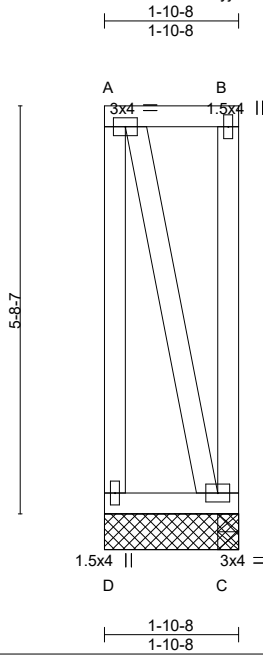

Scale: 3/8"=1'

LOADING (psf)	SPACING-	CSI.	DEFL.	in (loc)	l/defl	L/d	PLATES	GRIP
TCLL 25.0 (Roof Snow=25.0)	2-0-0 Plate Grip DOL 1.15 Lumber DOL 1.15	TC 0.05 BC 0.02 WB 0.00 Matrix-P	Vert(LL) -0.00 Vert(CT) -0.00 Horz(CT) 0.00 Wind(LL) 0.00	D	>999 >999 n/a ****	360 240 n/a 240	MT20	197/144
TCDL 12.0 BCLL 0.0 * BCDL 10.0	Rep Stress Incr NO Code IBC2018/TPI2014			C			Weight: 22 lb	FT = 20%

LUMBER-

TOP CHORD 2x4 SPF No.2
BOT CHORD 2x4 SPF No.2
WEBS 2x4 SPF No.2

BRACING-

TOP CHORD Structural wood sheathing directly applied or 1-10-8 oc purlins, except end verticals.
BOT CHORD Rigid ceiling directly applied or 10-0-0 oc bracing.

REACTIONS.

(size) D=1-10-8, C=1-10-8, C=1-10-8
Max Uplift D=-9(LC 4), C=-9(LC 4)
Max Grav D=74(LC 1), C=74(LC 1), C=74(LC 1)

FORCES. (lb) - Max. Comp./Max. Ten. - All forces 250 (lb) or less except when shown.

NOTES-

- 1) Wind: ASCE 7-16; Vult=115mph (3-second gust) Vasd=91mph; TCDL=4.2psf; BCDL=5.0psf; h=30ft; Ke=1.00; Cat. II; Exp B; Enclosed; MWFRS (envelope) gable end zone; Lumber DOL=1.33 plate grip DOL=1.33
- 2) Truss designed for wind loads in the plane of the truss only. For studs exposed to wind (normal to the face), see Standard Industry Gable End Details as applicable, or consult qualified building designer as per ANSI/TPI 1.
- 3) TCLL: ASCE 7-16; Pf=25.0 psf (Lum DOL = 1.15 Plate DOL = 1.15); Is=1.0; Rough Cat B; Partially Exp.; Ce=1.0; Cs=1.00; Ct=1.10
- 4) Provide adequate drainage to prevent water ponding.
- 5) Gable studs spaced at 2-0-0 oc.
- 6) This truss has been designed for a 10.0 psf bottom chord live load nonconcurrent with any other live loads.
- 7) * This truss has been designed for a live load of 20.0psf on the bottom chord in all areas where a rectangle 3-6-0 tall by 2-0-0 wide will fit between the bottom chord and any other members.
- 8) Provide mechanical connection (by others) of truss to bearing plate capable of withstanding 100 lb uplift at joint(s) D, C.
- 9) This truss is designed in accordance with the 2018 International Building Code section 2306.1 and referenced standard ANSI/TPI 1.



September 12, 2024

WARNING - Verify design parameters and READ NOTES ON THIS AND INCLUDED MITEK REFERENCE PAGE MII-7473 rev. 6/30/2020 BEFORE USE.

Design valid for use only with MiTek® connectors. This design is based only upon parameters shown, and is for an individual building component, not a truss system. Before use, the building designer must verify the applicability of design parameters and properly incorporate this design into the overall building design. Bracing indicated is to prevent buckling of individual truss web and/or chord members only. Additional temporary and permanent bracing is always required for stability and to prevent collapse with possible personal injury and property damage. For general guidance regarding the fabrication, storage, delivery, erection and bracing of trusses and truss systems, see

ANSI/TPI1 Quality Criteria, DSB-89 and BCSI Building Component Safety Information available from Truss Plate Institute, 2670 Crain Highway, Suite 203 Waldorf, MD 20601



240 Stirling Crescent
Bradford, ON. L3Z 4L5

Job	Truss	Truss Type	Qty	Ply	Buildings A-H	U1530868
N0653A	S17	BLOCKING STRUCTURAL	2	1		

Alliance Truss (CA), Abbotsford, BC - V2S 7P6,

8.820 s Aug 30 2024 MiTek Industries, Inc. Thu Sep 12 02:48:19 2024 Page 1

ID:hFyjDMxRTsEK_kgkR0vWWVzFigc-GCQteGD0xwTe6kL4s7IG0q2u55fEQKcSGBU?HeyeVqw

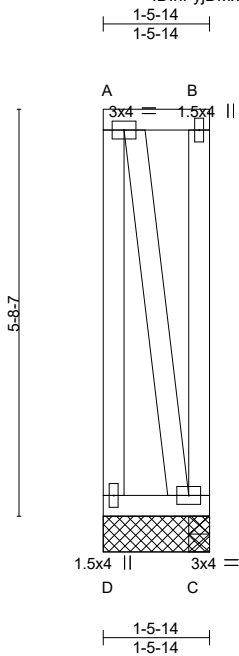

Scale: 3/8"=1'

LOADING (psf)	SPACING-	CSI.	DEFL.	in (loc)	l/defl	L/d	PLATES	GRIP
TCLL 25.0	2-0-0	TC 0.03	Vert(LL)	-0.00 D	>999	360	MT20	197/144
(Roof Snow=25.0)	Plate Grip DOL 1.15	BC 0.01	Vert(CT)	-0.00 D	>999	240		
TCDL 12.0	Lumber DOL 1.15	WB 0.00	Horz(CT)	-0.00 C	n/a	n/a		
BCLL 0.0 *	Rep Stress Incr NO	Matrix-P	Wind(LL)	0.00 D	****	240		
BCDL 10.0	Code IBC2018/TPI2014						Weight: 21 lb	FT = 20%

LUMBER-

TOP CHORD 2x4 SPF No.2
 BOT CHORD 2x4 SPF No.2
 WEBS 2x4 SPF No.2

BRACING-

TOP CHORD Structural wood sheathing directly applied or 1-5-14 oc purlins, except end verticals.
 BOT CHORD Rigid ceiling directly applied or 10-0-0 oc bracing.

REACTIONS.

(size) D=1-5-14, C=1-5-14, C=1-5-14
 Max Uplift D=-7(LC 4), C=-7(LC 4)
 Max Grav D=56(LC 1), C=56(LC 1), C=56(LC 1)

FORCES. (lb) - Max. Comp./Max. Ten. - All forces 250 (lb) or less except when shown.

NOTES-

- 1) Wind: ASCE 7-16; Vult=115mph (3-second gust) Vasd=91mph; TCDL=4.2psf; BCDL=5.0psf; h=30ft; Ke=1.00; Cat. II; Exp B; Enclosed; MWFRS (envelope) gable end zone; Lumber DOL=1.33 plate grip DOL=1.33
- 2) Truss designed for wind loads in the plane of the truss only. For studs exposed to wind (normal to the face), see Standard Industry Gable End Details as applicable, or consult qualified building designer as per ANSI/TPI 1.
- 3) TCLL: ASCE 7-16; Pf=25.0 psf (Lum DOL = 1.15 Plate DOL = 1.15); Is=1.0; Rough Cat B; Partially Exp.; Ce=1.0; Cs=1.00; Ct=1.10
- 4) Provide adequate drainage to prevent water ponding.
- 5) Gable studs spaced at 2-0-0 oc.
- 6) This truss has been designed for a 10.0 psf bottom chord live load nonconcurrent with any other live loads.
- 7) * This truss has been designed for a live load of 20.0psf on the bottom chord in all areas where a rectangle 3-6-0 tall by 2-0-0 wide will fit between the bottom chord and any other members.
- 8) Provide mechanical connection (by others) of truss to bearing plate capable of withstanding 100 lb uplift at joint(s) D, C.
- 9) This truss is designed in accordance with the 2018 International Building Code section 2306.1 and referenced standard ANSI/TPI 1.



September 12, 2024

WARNING - Verify design parameters and READ NOTES ON THIS AND INCLUDED MITEK REFERENCE PAGE MII-7473 rev. 6/30/2020 BEFORE USE.

Design valid for use only with MiTek® connectors. This design is based only upon parameters shown, and is for an individual building component, not a truss system. Before use, the building designer must verify the applicability of design parameters and properly incorporate this design into the overall building design. Bracing indicated is to prevent buckling of individual truss web and/or chord members only. Additional temporary and permanent bracing is always required for stability and to prevent collapse with possible personal injury and property damage. For general guidance regarding the fabrication, storage, delivery, erection and bracing of trusses and truss systems, see

ANSI/TPI1 Quality Criteria, DSB-89 and BCSI Building Component

Safety Information available from Truss Plate Institute, 2670 Crain Highway, Suite 203 Waldorf, MD 20601



240 Stirling Crescent
 Bradford, ON. L3Z 4L5

Job	Truss	Truss Type	Qty	Ply	Buildings A-H	U1530869
N0653A	S18	BLOCKING STRUCTURAL	1	1		

Alliance Truss (CA), Abbotsford, BC - V2S 7P6,

8.820 s Aug 30 2024 MiTek Industries, Inc. Thu Sep 12 02:48:19 2024 Page 1

ID:hFyjDMxrTsEK_kgkR0vWVvzFfgc-GCQteGDOxwTe6kL4s7IG0q2kw5fUQAWSGBU?HeyeVqw

1-7-0
1-7-0

Scale: 1/4"=1'

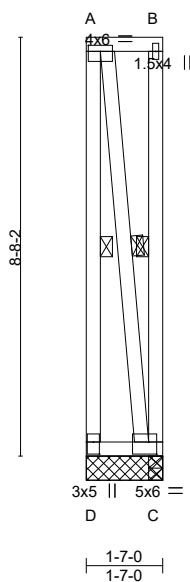

Plate Offsets (X,Y)-- [A:0-3-0,0-1-8], [C:0-2-0,0-3-0], [D:0-3-0,0-1-8]

LOADING (psf)	SPACING-	CSI.	DEFL.	in (loc)	l/defl	L/d	PLATES	GRIP
TCLL 25.0 (Roof Snow=25.0)	2-0-0 Plate Grip DOL 1.15 Lumber DOL 1.15	TC 0.68 BC 0.06 WB 0.68 Matrix-P	Vert(LL) -0.00 Vert(CT) -0.00 Horz(CT) 0.00 Wind(LL) 0.00	D	>999	360	MT20	197/144
TCDL 12.0	Rep Stress Incr NO Code IBC2018/TPI2014			D	>999	240		
BCLL 0.0 *				C	n/a	n/a		
BCDL 10.0				D	****	240	Weight: 31 lb	FT = 20%

LUMBER-

TOP CHORD 2x4 SPF No.2
 BOT CHORD 2x4 SPF No.2
 WEBS 2x4 SPF No.2

BRACING-

TOP CHORD Structural wood sheathing directly applied or 1-7-0 oc purlins, except end verticals.
 BOT CHORD Rigid ceiling directly applied or 6-0-0 oc bracing.
 WEBS 1 Row at midpt A-D, B-C, A-C

REACTIONS.

(size) D=1-7-0, C=1-7-0, C=1-7-0
 Max Uplift D=-2020(LC 23), C=-2020(LC 24)
 Max Grav D=2041(LC 44), C=2041(LC 43), C=61(LC 1)

FORCES. (lb) - Max. Comp./Max. Ten. - All forces 250 (lb) or less except when shown.

TOP CHORD A-D=-2028/2026, A-B=-279/279
 BOT CHORD C-D=-279/279
 WEBS A-C=-2036/2036

NOTES-

- 1) Wind: ASCE 7-16; Vult=115mph (3-second gust) Vasd=91mph; TCDL=4.2psf; BCDL=5.0psf; h=30ft; Ke=1.00; Cat. II; Exp B; Enclosed; MWFRS (envelope) gable end zone; Lumber DOL=1.33 plate grip DOL=1.33
- 2) Truss designed for wind loads in the plane of the truss only. For studs exposed to wind (normal to the face), see Standard Industry Gable End Details as applicable, or consult qualified building designer as per ANSI/TPI 1.
- 3) TCLL: ASCE 7-16; Pf=25.0 psf (Lum DOL = 1.15 Plate DOL = 1.15); Is=1.0; Rough Cat B; Partially Exp.; Ce=1.0; Cs=1.00; Ct=1.10
- 4) Provide adequate drainage to prevent water ponding.
- 5) Gable studs spaced at 2-0-0 oc.
- 6) This truss has been designed for a 10.0 psf bottom chord live load nonconcurrent with any other live loads.
- 7) * This truss has been designed for a live load of 20.0psf on the bottom chord in all areas where a rectangle 3-6-0 tall by 2-0-0 wide will fit between the bottom chord and any other members.
- 8) Provide mechanical connection (by others) of truss to bearing plate capable of withstanding 100 lb uplift at joint(s) except (jt=lb) D=2020, C=2020.
- 9) This truss is designed in accordance with the 2018 International Building Code section 2306.1 and referenced standard ANSI/TPI 1.
- 10) This truss has been designed for a total drag load of 240 plf. Lumber DOL=(1.33) Plate grip DOL=(1.33) Connect truss to resist drag loads along bottom chord from 0-0-0 to 1-7-0 for 240.1 plf.



September 12, 2024

WARNING - Verify design parameters and READ NOTES ON THIS AND INCLUDED MITEK REFERENCE PAGE MII-7473 rev. 6/30/2020 BEFORE USE.

Design valid for use only with MiTek® connectors. This design is based only upon parameters shown, and is for an individual building component, not a truss system. Before use, the building designer must verify the applicability of design parameters and properly incorporate this design into the overall building design. Bracing indicated is to prevent buckling of individual truss web and/or chord members only. Additional temporary and permanent bracing is always required for stability and to prevent collapse with possible personal injury and property damage. For general guidance regarding the fabrication, storage, delivery, erection and bracing of trusses and truss systems, see

ANSI/TPI1 Quality Criteria, DSB-89 and BCSI Building Component Safety Information available from Truss Plate Institute, 2670 Crain Highway, Suite 203 Waldorf, MD 20601



240 Stirling Crescent
 Bradford, ON. L3Z 4L5

Job	Truss	Truss Type	Qty	Ply	Buildings A-H	U1530870
N0653A	S19	BLOCKING SUPPORTED	1	1		

Alliance Truss (CA), Abbotsford, BC - V2S 7P6,

8.820 s Aug 30 2024 MiTek Industries, Inc. Thu Sep 12 02:48:20 2024 Page 1

ID:hFyjDMxrTsEK_kgkR0vWWVzFfgc-kP_FrcE1iEbVkuvGQqDVZ2btaU?y9b9cVrEYp4yeVqv

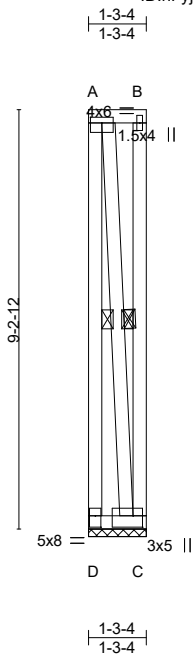

Scale = 1:50.7

Plate Offsets (X,Y)-- [A:0-3-0,0-1-8], [C:0-2-8,0-3-0], [D:0-3-0,0-1-8]

LOADING (psf)		SPACING-		CSI.		DEFL.				PLATES	GRIP	
TCLL	25.0	Plate Grip DOL	1.15	TC	0.81	Vert(LL)	n/a	-	n/a	999	MT20	197/144
(Roof Snow=25.0)		Lumber DOL	1.15	BC	0.05	Vert(CT)	n/a	-	n/a	999		
TCDL	12.0	Rep Stress Incr	NO	WB	0.81	Horz(CT)	0.00	C	n/a	n/a		
BCLL	0.0 *	Code IBC2018/TPI2014		Matrix-P							Weight: 33 lb	FT = 20%
BCDL	10.0											

LUMBER-

TOP CHORD 2x4 SPF No.2
 BOT CHORD 2x4 SPF No.2
 WEBS 2x4 SPF No.2

BRACING-

TOP CHORD Structural wood sheathing directly applied or 1-3-4 oc purlins, except end verticals.
 BOT CHORD Rigid ceiling directly applied or 6-0-0 oc bracing.
 WEBS 1 Row at midpt A-D, B-C, A-C

REACTIONS.

(size) D=1-3-4, C=1-3-4
 Max Uplift D=-2151(LC 23), C=-2151(LC 24)
 Max Grav D=2167(LC 44), C=2167(LC 43)

FORCES. (lb) - Max. Comp./Max. Ten. - All forces 250 (lb) or less except when shown.

TOP CHORD A-D=-2157/2156
 WEBS A-C=-2158/2158

NOTES-

- 1) Wind: ASCE 7-16; Vult=115mph (3-second gust) Vasd=91mph; TCDL=4.2psf; BCDL=5.0psf; h=30ft; Ke=1.00; Cat. II; Exp B; Enclosed; MWFRS (envelope) gable end zone; Lumber DOL=1.33 plate grip DOL=1.33
- 2) Truss designed for wind loads in the plane of the truss only. For studs exposed to wind (normal to the face), see Standard Industry Gable End Details as applicable, or consult qualified building designer as per ANSI/TPI 1.
- 3) TCLL: ASCE 7-16; Pf=25.0 psf (Lum DOL = 1.15 Plate DOL = 1.15); Is=1.0; Rough Cat B; Partially Exp.; Ce=1.0; Cs=1.00; Ct=1.10
- 4) Provide adequate drainage to prevent water ponding.
- 5) Gable requires continuous bottom chord bearing.
- 6) Truss to be fully sheathed from one face or securely braced against lateral movement (i.e. diagonal web).
- 7) Gable studs spaced at 2-0-0 oc.
- 8) This truss has been designed for a 10.0 psf bottom chord live load nonconcurrent with any other live loads.
- 9) * This truss has been designed for a live load of 20.0psf on the bottom chord in all areas where a rectangle 3-6-0 tall by 2-0-0 wide will fit between the bottom chord and any other members.
- 10) Provide mechanical connection (by others) of truss to bearing plate capable of withstanding 100 lb uplift at joint(s) except (jt=lb) D=2151, C=2151.
- 11) This truss is designed in accordance with the 2018 International Building Code section 2306.1 and referenced standard ANSI/TPI 1.
- 12) This truss has been designed for a total drag load of 240 plf. Lumber DOL=(1.33) Plate grip DOL=(1.33) Connect truss to resist drag loads along bottom chord from 0-0-0 to 1-3-4 for 240.0 plf.



September 12, 2024

WARNING - Verify design parameters and READ NOTES ON THIS AND INCLUDED MITEK REFERENCE PAGE MII-7473 rev. 6/30/2020 BEFORE USE.

Design valid for use only with MiTek® connectors. This design is based only upon parameters shown, and is for an individual building component, not a truss system. Before use, the building designer must verify the applicability of design parameters and properly incorporate this design into the overall building design. Bracing indicated is to prevent buckling of individual truss web and/or chord members only. Additional temporary and permanent bracing is always required for stability and to prevent collapse with possible personal injury and property damage. For general guidance regarding the fabrication, storage, delivery, erection and bracing of trusses and truss systems, see

Safety Information available from Truss Plate Institute, 2670 Crain Highway, Suite 203 Waldorf, MD 20601

ANSI/TPI1 Quality Criteria, DSB-89 and BCSI Building Component



240 Stirling Crescent
 Bradford, ON. L3Z 4L5

Job	Truss	Truss Type	Qty	Ply	Buildings A-H	U1530871
N0653A	T1	GABLE	9	1		

Job Reference (optional)

Alliance Truss (CA), Abbotsford, BC - V2S 7P6, 8.820 s Aug 30 2024 MiTek Industries, Inc. Thu Sep 12 02:48:25 2024 Page 1
 ID:hFyjDMxrTsEK_kgkR0vWVvzF1gc-4Mo8uJI9WmDnqfoECNphG5Ik9VW_qqelF7xJUHYeVqq

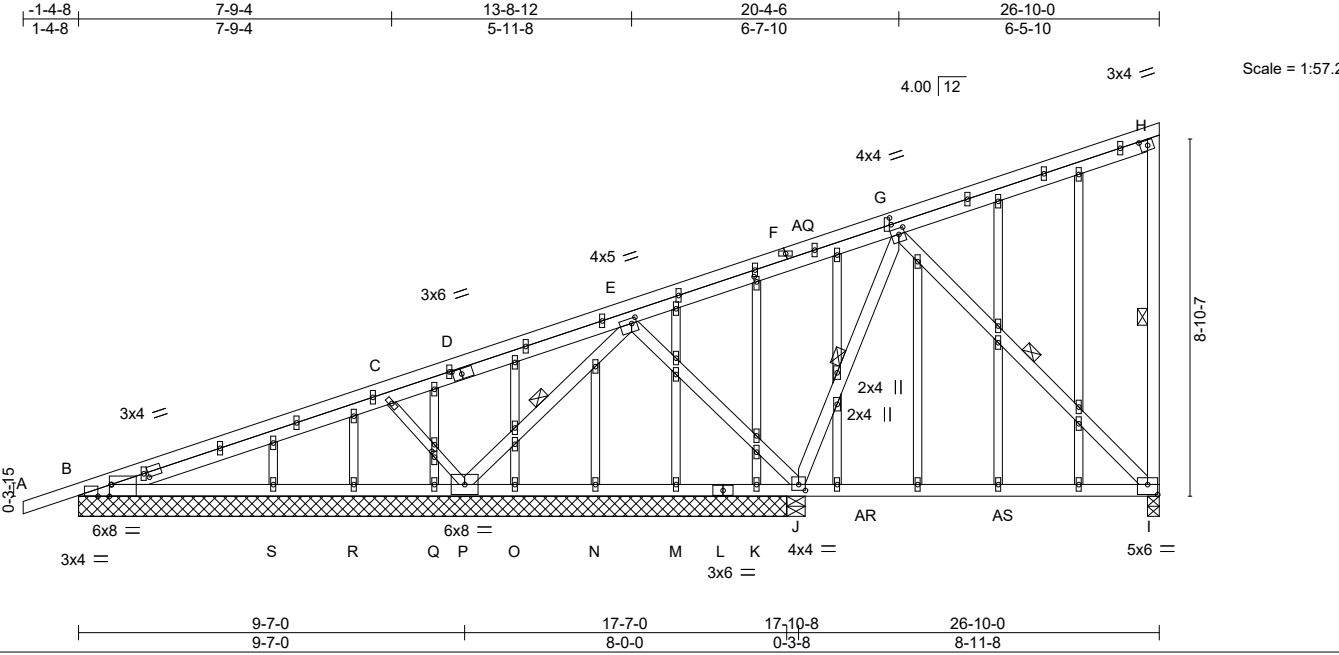

Plate Offsets (X,Y)--	[B:0-0-9,Edge], [B:0-11-7,0-1-8], [B:0-4-0,Edge], [D:0-2-10,0-1-8], [E:0-1-8,0-1-8], [G:0-2-0,0-0-8], [G:0-1-12,0-1-12], [H:0-2-4,0-1-8], [I:0-3-0,0-3-0], [J:0-2-0,0-1-12], [AF:0-1-9,0-0-12], [AM:0-1-12,0-0-12]
-----------------------	--

LOADING (psf)	SPACING-	CSI.	DEFL.	in (loc)	l/defl	L/d	PLATES	GRIP
TCLL 25.0 (Roof Snow=25.0)	2-0-0	TC 0.82	Vert(LL) -0.22	I-J	>478	360	MT20	197/144
TCDL 12.0	Lumber DOL 1.15	BC 0.89	Vert(CT) -0.37	I-J	>288	240		
BCLL 0.0 *	Rep Stress Incr YES	WB 0.93	Horz(CT) -0.02	N	n/a	n/a		
BCDL 10.0	Code IBC2018/TPI2014	Matrix-S	Wind(LL) -0.04	I-J	>999	240	Weight: 176 lb	FT = 20%

LUMBER-	BRACING-
TOP CHORD 2x4 SPF No.2	TOP CHORD Structural wood sheathing directly applied or 3-4-15 oc purlins, except end verticals.
BOT CHORD 2x4 SPF No.2	BOT CHORD Rigid ceiling directly applied or 3-6-7 oc bracing.
WEBS 2x4 SPF No.2 *Except* C-P: 2x3 SPF No.2	WEBS 1 Row at midpt H-I, E-P, G-J, G-I
OTHERS 2x3 SPF No.2	

REACTIONS. All bearings 17-7-0 except (jt=length) I=0-3-8, J=0-5-8.
 (lb) - Max Horz B=434(LC 38)
 Max Uplift All uplift 100 lb or less at joint(s) R except I=-871(LC 41), B=-806(LC 32), P=-2103(LC 40), J=-318(LC 32), K=-446(LC 19)
 Max Grav All reactions 250 lb or less at joint(s) M, N, O, Q, R, S except I=1117(LC 28), B=921(LC 29), P=2141(LC 53), J=1434(LC 29)

FORCES. (lb) - Max. Comp./Max. Ten. - All forces 250 (lb) or less except when shown.
 TOP CHORD B-C=-2718/2502, C-E=-1022/984, E-G=-2148/1999, G-H=-1764/1659, H-I=-301/52
 BOT CHORD B-S=-2719/2495, R-S=-948/845, Q-R=-820/717, P-Q=-1096/992, O-P=-882/804,
 N-O=-480/402, M-N=-1213/1134, K-M=-1945/1862, J-K=-2328/2249, I-J=-886/836
 WEBS C-P=-559/200, E-P=-2729/2683, E-J=-1440/1477, G-J=-1516/1417, G-I=-1175/1213

- NOTES-**
- 1) Wind: ASCE 7-16; Vult=115mph (3-second gust) Vasd=91mph; TCDL=4.2psf; BCDL=5.0psf; h=30ft; Ke=1.00; Cat. II; Exp B; Enclosed; MWFRS (envelope) gable end zone; cantilever left and right exposed ; end vertical left and right exposed; Lumber DOL=1.33 plate grip DOL=1.33
 - 2) Truss designed for wind loads in the plane of the truss only. For studs exposed to wind (normal to the face), see Standard Industry Gable End Details as applicable, or consult qualified building designer as per ANSI/TPI 1.
 - 3) TCLL: ASCE 7-16; Pf=25.0 psf (Lum DOL = 1.15 Plate DOL = 1.15); Is=1.0; Rough Cat B; Partially Exp.; Ce=1.0; Cs=1.00; Ct=1.10
 - 4) Unbalanced snow loads have been considered for this design.
 - 5) This truss has been designed for greater of min roof live load of 20.0 psf or 2.00 times flat roof load of 25.0 psf on overhangs non-concurrent with other live loads.
 - 6) All plates are 1.5x4 MT20 unless otherwise indicated.
 - 7) Gable studs spaced at 2-0-0 oc.
 - 8) This truss has been designed for a 10.0 psf bottom chord live load nonconcurrent with any other live loads.
 - 9) * This truss has been designed for a live load of 20.0psf on the bottom chord in all areas where a rectangle 3-6-0 tall by 2-0-0 wide will fit between the bottom chord and any other members, with BCDL = 10.0psf.
 - 10) Provide mechanical connection (by others) of truss to bearing plate capable of withstanding 100 lb uplift at joint(s) R except (jt=lb) I=871, B=806, P=2103, J=318, K=446.
 - 11) This truss is designed in accordance with the 2018 International Building Code section 2306.1 and referenced standard ANSI/TPI 1.
 - 12) This truss has been designed for a total drag load of 240 plf. Lumber DOL=(1.33) Plate grip DOL=(1.33) Connect truss to resist continuous loading on bottom chord from 0-0-0 to 17-7-0 for 366.3 plf.



September 12, 2024

WARNING - Verify design parameters and READ NOTES ON THIS AND INCLUDED MITTEK REFERENCE PAGE MII-7473 rev. 6/30/2020 BEFORE USE.
 Design valid for use only with MiTek® connectors. This design is based only on parameters shown, and is for an individual building component, not a truss system. Before use, the building designer must verify the applicability of design parameters and properly incorporate this design into the overall building design. Bracing indicated is to prevent buckling of individual truss web and/or chord members only. Additional temporary and permanent bracing is always required for stability and to prevent collapse with possible personal injury and property damage. For general guidance regarding the fabrication, storage, delivery, erection and bracing of trusses and truss systems, see **ANSI/TPI1 Quality Criteria, DSB-89 and BCSI Building Component Safety Information** available from Truss Plate Institute, 2670 Crain Highway, Suite 203 Waldorf, MD 20601



240 Stirling Crescent
 Bradford, ON. L3Z 4L5

Job	Truss	Truss Type	Qty	Ply	Buildings A-H
N0653A	T1	GABLE	9	1	U1530871

Alliance Truss (CA), Abbotsford, BC - V2S 7P6,

8.820 s Aug 30 2024 MiTek Industries, Inc. Thu Sep 12 02:48:26 2024 Page 2
ID:hFyjDMxrTsEK_kgkR0vWWVzFgc-ZZLW6fJnH4LeSpNQm5KwoJruvvrDZHUtnhs0kyeVqp

NOTES-

- 13) No notches allowed in overhang and 10408 from left end and 0 from right end or 12" along rake from scarf, whichever is larger. Minimum 1.5x4 tie plates required at 2-0-0 o.c. maximum between the stacking chords. For edge-wise notching, provide at least one tie plate between each notch.

WARNING - Verify design parameters and READ NOTES ON THIS AND INCLUDED MITEK REFERENCE PAGE MII-7473 rev. 6/30/2020 BEFORE USE.

Design valid for use only with MiTek® connectors. This design is based only upon parameters shown, and is for an individual building component, not a truss system. Before use, the building designer must verify the applicability of design parameters and properly incorporate this design into the overall building design. Bracing indicated is to prevent buckling of individual truss web and/or chord members only. Additional temporary and permanent bracing is always required for stability and to prevent collapse with possible personal injury and property damage. For general guidance regarding the fabrication, storage, delivery, erection and bracing of trusses and truss systems, see

Safety Information available from Truss Plate Institute, 2670 Crain Highway, Suite 203 Waldorf, MD 20601



240 Stirling Crescent
Bradford, ON. L3Z 4L5

Job N0653A	Truss T2	Truss Type Monopitch	Qty 45	Ply 1	Buildings A-H Job Reference (optional)	U1530872
---------------	-------------	-------------------------	-----------	----------	---	----------

Alliance Truss (CA), Abbotsford, BC - V2S 7P6,

8.820 s Aug 30 2024 MiTek Industries, Inc. Thu Sep 12 02:48:26 2024 Page 1

ID:hFyjDMxrTsEK_kgkR0vWWVzFgC-ZZLW6fJnH4LeSpNQm5KwoJrs6vq9ZITUtnhs0kyeVqp

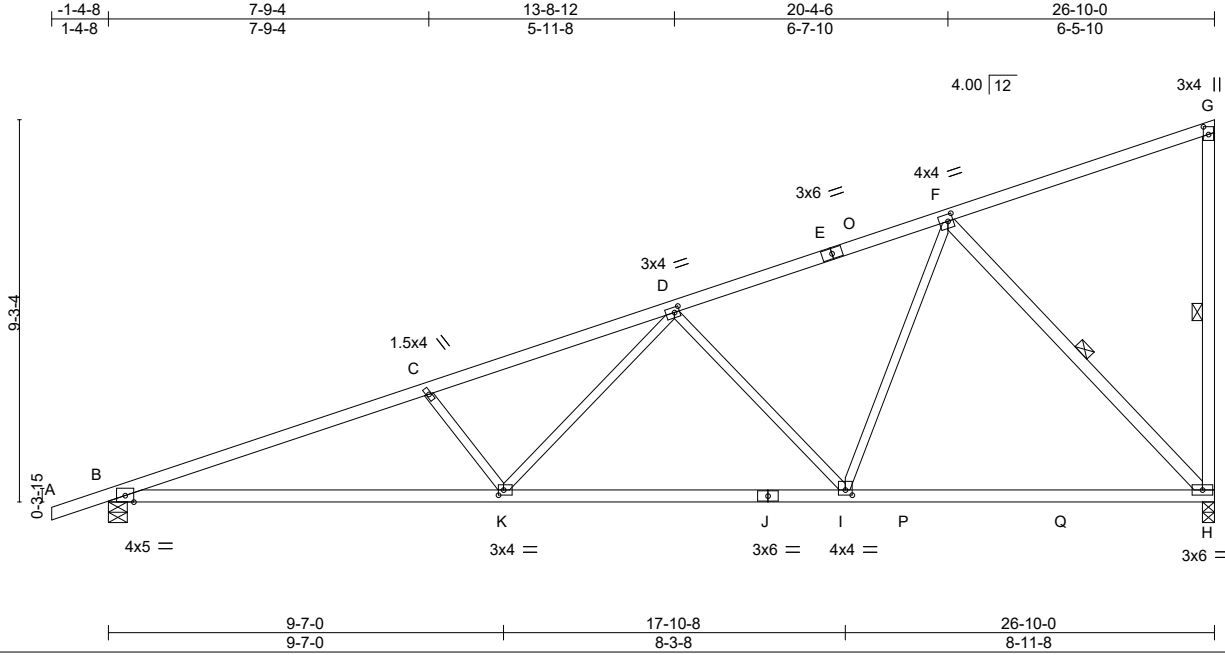

Plate Offsets (X,Y)-- [D:0-1-8,0-1-8], [F:0-1-8,0-2-0], [G:0-2-4,0-1-8], [I:0-2-0,0-1-8], [K:0-1-8,0-1-8]

LOADING (psf)	SPACING-	CSI.	DEFL.	PLATES	GRIP
TCLL 25.0 (Roof Snow=25.0)	2-0-0 Plate Grip DOL 1.15 Lumber DOL 1.15	TC 0.94 BC 0.95 WB 0.89 Matrix-MS	in (loc) l/defl L/d Vert(LL) -0.31 H-I >999 360 Vert(CT) -0.55 K-N >587 240 Horz(CT) 0.07 H n/a n/a Wind(LL) 0.13 K-N >999 240	MT20	197/144
TCDL 12.0	Rep Stress Incr YES Code IBC2018/TPI2014			Weight: 103 lb	FT = 20%
BCLL 0.0 *					
BCDL 10.0					

LUMBER-	BRACING-
TOP CHORD 2x4 SPF No.2	TOP CHORD Structural wood sheathing directly applied, except end verticals.
BOT CHORD 2x4 SPF No.2 *Except*	BOT CHORD Rigid ceiling directly applied or 2-2-0 oc bracing.
B-J: 2x4 SPF 2100F 1.8E	WEBS 1 Row at midpt G-H, F-H
WEBS 2x3 SPF No.2 *Except*	
G-H,F-H: 2x4 SPF No.2	

REACTIONS. (size) H=0-3-8, B=0-5-8
 Max Horz B=301(LC 9)
 Max Uplift H=-180(LC 10), B=-182(LC 6)
 Max Grav H=1537(LC 3), B=1425(LC 3)

FORCES. (lb) - Max. Comp./Max. Ten. - All forces 250 (lb) or less except when shown.
 TOP CHORD B-C=-3139/325, C-D=-2876/291, D-F=-1586/171, G-H=-296/51
 BOT CHORD B-K=-394/2941, I-K=-249/2033, H-I=-112/1082
 WEBS C-K=-534/165, D-K=-71/947, D-I=-914/199, F-I=-64/1078, F-H=-1568/234

- NOTES-**
- 1) Wind: ASCE 7-16; Vult=115mph (3-second gust) Vasd=91mph; TCDL=4.2psf; BCDL=5.0psf; h=30ft; Ke=1.00; Cat. II; Exp B; Enclosed; MWFRS (envelope) gable end zone; cantilever left and right exposed ; end vertical left and right exposed; Lumber DOL=1.33 plate grip DOL=1.33
 - 2) TCLL: ASCE 7-16; Pf=25.0 psf (Lum DOL = 1.15 Plate DOL = 1.15); Is=1.0; Rough Cat B; Partially Exp.; Ce=1.0; Cs=1.00; Ct=1.10
 - 3) Unbalanced snow loads have been considered for this design.
 - 4) This truss has been designed for greater of min roof live load of 20.0 psf or 2.00 times flat roof load of 25.0 psf on overhangs non-concurrent with other live loads.
 - 5) This truss has been designed for a 10.0 psf bottom chord live load nonconcurrent with any other live loads.
 - 6) * This truss has been designed for a live load of 20.0psf on the bottom chord in all areas where a rectangle 3-6-0 tall by 2-0-0 wide will fit between the bottom chord and any other members, with BCDL = 10.0psf.
 - 7) Provide mechanical connection (by others) of truss to bearing plate capable of withstanding 100 lb uplift at joint(s) except (jt=lb) H=180, B=182.
 - 8) This truss is designed in accordance with the 2018 International Building Code section 2306.1 and referenced standard ANSI/TPI 1.



September 12, 2024

WARNING - Verify design parameters and READ NOTES ON THIS AND INCLUDED MITEK REFERENCE PAGE MII-7473 rev. 6/30/2020 BEFORE USE.
 Design valid for use only with MiTek® connectors. This design is based only upon parameters shown, and is for an individual building component, not a truss system. Before use, the building designer must verify the applicability of design parameters and properly incorporate this design into the overall building design. Bracing indicated is to prevent buckling of individual truss web and/or chord members only. Additional temporary and permanent bracing is always required for stability and to prevent collapse with possible personal injury and property damage. For general guidance regarding the fabrication, storage, delivery, erection and bracing of trusses and truss systems, see **ANSI/TPI1 Quality Criteria, DSB-89 and BCSI Building Component Safety Information** available from Truss Plate Institute, 2670 Crain Highway, Suite 203 Waldorf, MD 20601



240 Stirling Crescent
Bradford, ON. L3Z 4L5

Job N0653A	Truss T2A	Truss Type MONOPITCH	Qty 54	Ply 1	Buildings A-H Job Reference (optional)	U1530873
---------------	--------------	-------------------------	-----------	----------	---	----------

Alliance Truss (CA), Abbotsford, BC - V2S 7P6,

8.820 s Aug 30 2024 MiTek Industries, Inc. Thu Sep 12 02:48:27 2024 Page 1

ID:hFyjDMxrTsEK_kgkR0vWVzFlgc-1lvuJ?JQ2NTV3yyycKor9LWN1dJBxIje6RQQZAyeVqo

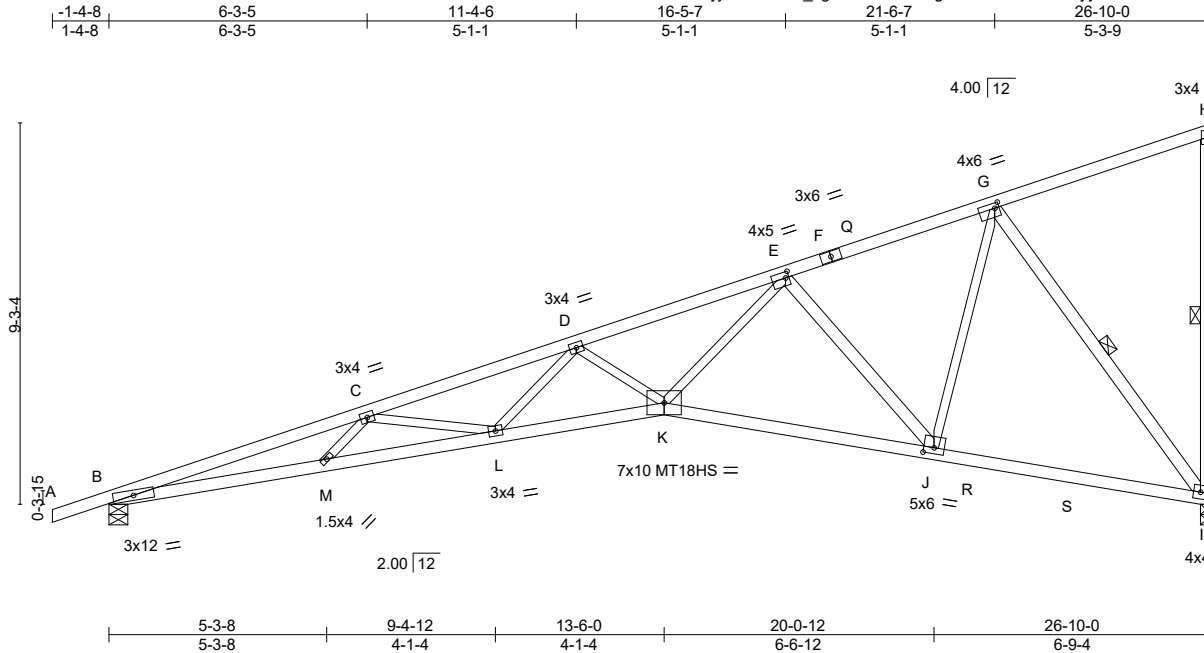

Scale = 1:56.0

Plate Offsets (X,Y)-- [E:0-1-0,0-1-12], [G:0-1-4,0-1-8], [J:0-3-0,0-1-12]

LOADING (psf)	SPACING-	CSI.	DEFL.	PLATES	GRIP
TCLL 25.0 (Roof Snow=25.0)	2-0-0 Plate Grip DOL 1.15 Lumber DOL 1.15	TC 0.95 BC 0.86 WB 0.95 Matrix-MS	in (loc) l/defl L/d Vert(LL) -0.47 L-M >676 360 Vert(CT) -0.84 L-M >381 240 Horz(CT) 0.38 I n/a n/a Wind(LL) 0.26 L >999 240	MT20 MT18HS Weight: 108 lb	197/144 197/144 FT = 20%

LUMBER-

TOP CHORD 2x4 SPF No.2
 BOT CHORD 2x4 SPF No.2 *Except*
 B-K: 2x4 SPF 2100F 1.8E
 WEBS 2x3 SPF No.2 *Except*
 H-I,E-J,G-I: 2x4 SPF No.2

BRACING-

TOP CHORD Structural wood sheathing directly applied, except end verticals.
 BOT CHORD Rigid ceiling directly applied or 8-3-15 oc bracing.
 WEBS 1 Row at midpt H-I, G-I

REACTIONS.

(size) I=0-3-8, B=0-5-8
 Max Horz B=287(LC 6)
 Max Uplift I=-203(LC 10), B=-157(LC 6)
 Max Grav I=1527(LC 17), B=1420(LC 3)

FORCES.

(lb) - Max. Comp./Max. Ten. - All forces 250 (lb) or less except when shown.
 TOP CHORD B-C=-5834/640, C-D=-5172/569, D-E=-4129/458, E-G=-1440/103
 BOT CHORD B-M=-847/5559, L-M=-895/5544, K-L=-705/4549, J-K=-364/2361, I-J=-148/1041
 WEBS C-L=-639/168, D-L=-34/622, D-K=-790/170, E-K=-307/2345, E-J=-1608/290,
 G-J=-116/1349, G-I=-1717/245

NOTES-

- 1) Wind: ASCE 7-16; Vult=115mph (3-second gust) Vasd=91mph; TCCL=4.2psf; BCDL=5.0psf; h=30ft; Ke=1.00; Cat. II; Exp B; Enclosed; MWFRS (envelope) gable end zone; cantilever left exposed ; end vertical left exposed; Lumber DOL=1.33 plate grip DOL=1.33
- 2) TCLL: ASCE 7-16; Pf=25.0 psf (Lum DOL = 1.15 Plate DOL = 1.15); Is=1.0; Rough Cat B; Partially Exp.; Ce=1.0; Cs=1.00; Ct=1.10
- 3) Unbalanced snow loads have been considered for this design.
- 4) This truss has been designed for greater of min roof live load of 20.0 psf or 2.00 times flat roof load of 25.0 psf on overhangs non-concurrent with other live loads.
- 5) All plates are MT20 plates unless otherwise indicated.
- 6) This truss has been designed for a 10.0 psf bottom chord live load nonconcurrent with any other live loads.
- 7) * This truss has been designed for a live load of 20.0psf on the bottom chord in all areas where a rectangle 3-6-0 tall by 2-0-0 wide will fit between the bottom chord and any other members, with BCDL = 10.0psf.
- 8) Bearing at joint(s) I, B considers parallel to grain value using ANSI/TPI 1 angle to grain formula. Building designer should verify capacity of bearing surface.
- 9) Provide mechanical connection (by others) of truss to bearing plate capable of withstanding 100 lb uplift at joint(s) except (jt=lb) I=203, B=157.
- 10) This truss is designed in accordance with the 2018 International Building Code section 2306.1 and referenced standard ANSI/TPI 1.



September 12, 2024

WARNING - Verify design parameters and READ NOTES ON THIS AND INCLUDED MITEK REFERENCE PAGE MII-7473 rev. 6/30/2020 BEFORE USE.

Design valid for use only with MiTek® connectors. This design is based only upon parameters shown, and is for an individual building component, not a truss system. Before use, the building designer must verify the applicability of design parameters and properly incorporate this design into the overall building design. Bracing indicated is to prevent buckling of individual truss web and/or chord members only. Additional temporary and permanent bracing is always required for stability and to prevent collapse with possible personal injury and property damage. For general guidance regarding the fabrication, storage, delivery, erection and bracing of trusses and truss systems, see

ANSI/TPI1 Quality Criteria, DSB-89 and BCSI Building Component Safety Information available from Truss Plate Institute, 2670 Crain Highway, Suite 203 Waldorf, MD 20601



240 Stirling Crescent
 Bradford, ON. L3Z 4L5

Job N0653A	Truss T3	Truss Type GABLE	Qty 9	Ply 1	Buildings A-H Job Reference (optional)	U1530874
---------------	-------------	---------------------	----------	----------	---	----------

Alliance Truss (CA), Abbotsford, BC - V2S 7P6, 8.820 s Aug 30 2024 MiTek Industries, Inc. Thu Sep 12 02:48:28 2024 Page 1

ID:hFyjDMxrTsEK_kgkR0vWWVzFgC-VxTHXK2phbMh6XpuWMOukwENjcp1BunL5Az5cyeVqn

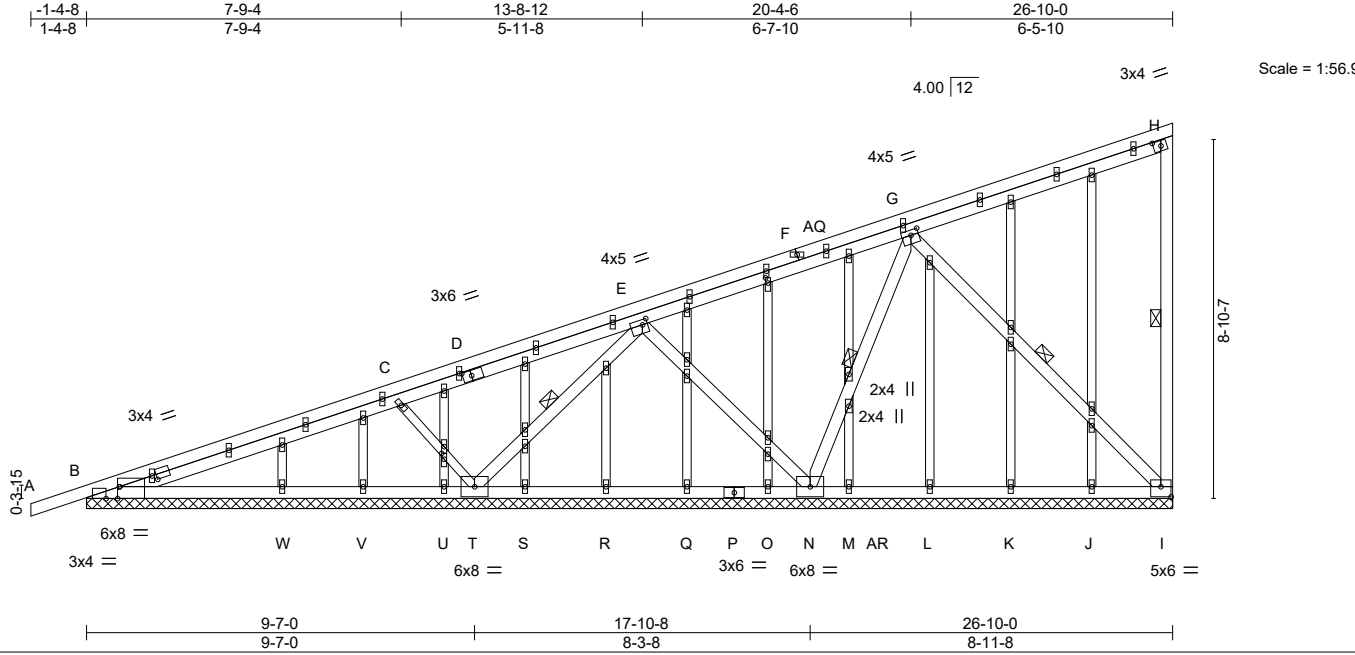

Plate Offsets (X,Y)--	[B:0-0-9,Edge], [B:0-11-7,0-1-8], [B:0-4-0,Edge], [D:0-2-10,0-1-8], [E:0-1-8,0-1-8], [G:0-2-4,0-1-8], [H:0-2-4,0-1-8], [I:0-3-0,0-3-0], [AF:0-1-9,0-0-12], [AM:0-1-12,0-0-12]
-----------------------	---

LOADING (psf)	SPACING-	CSI.	DEFL.	in (loc)	l/defl	L/d	PLATES	GRIP
TCLL 25.0 (Roof Snow=25.0)	2-0-0	TC 0.82	Vert(LL)	-0.01	A	n/r	MT20	197/144
TCDL 12.0	Plate Grip DOL 1.15	BC 0.56	Vert(CT)	0.04	A	n/r		
BCLL 0.0 *	Lumber DOL 1.15	WB 0.89	Horz(CT)	-0.03	K	n/a		
BCDL 10.0	Rep Stress Incr YES	Matrix-S					Weight: 176 lb	FT = 20%
	Code IBC2018/TPI2014							

LUMBER-	BRACING-
TOP CHORD 2x4 SPF No.2	TOP CHORD Structural wood sheathing directly applied or 3-8-5 oc purlins, except end verticals.
BOT CHORD 2x4 SPF No.2	BOT CHORD Rigid ceiling directly applied or 3-11-1 oc bracing.
WEBS 2x4 SPF No.2 *Except*	WEBS 1 Row at midpt H-I, E-T, G-N, G-I
C-T: 2x3 SPF No.2	
OTHERS 2x3 SPF No.2	

REACTIONS. All bearings 26-10-0.
 (lb) - Max Horz B=291(LC 38)
 Max Uplift All uplift 100 lb or less at joint(s) J, V except I=1199(LC 35), B=704(LC 32), T=2021(LC 40), N=900(LC 40)
 Max Grav All reactions 250 lb or less at joint(s) J, K, L, M, O, Q, R, S, U, V, W except I=1231(LC 28), B=844(LC 29), T=2060(LC 53), N=1177(LC 29)

FORCES. (lb) - Max. Comp./Max. Ten. - All forces 250 (lb) or less except when shown.
 TOP CHORD B-C=-2361/2145, C-E=-1374/1337, E-G=-1682/1537, G-H=-1756/1658, H-I=-302/52
 BOT CHORD B-W=-2234/2014, V-W=-1074/970, U-V=-594/442, T-U=-352/288, S-T=-1564/1483, R-S=-1294/1213, Q-R=-814/733, O-Q=-367/286, N-O=-593/512, M-N=-1104/1049, L-M=-897/843, K-L=-417/389, J-K=-725/670, I-J=-1170/1115
 WEBS C-T=-559/189, E-T=-2629/2583, E-N=-1389/1425, G-N=-1915/1874, G-I=-1577/1612

- NOTES-**
- 1) Wind: ASCE 7-16; Vult=115mph (3-second gust) Vasd=91mph; TCDL=4.2psf; BCDL=5.0psf; h=30ft; Ke=1.00; Cat. II; Exp B; Enclosed; MWFRS (envelope) gable end zone; cantilever left and right exposed; end vertical left and right exposed; Lumber DOL=1.33 plate grip DOL=1.33
 - 2) Truss designed for wind loads in the plane of the truss only. For studs exposed to wind (normal to the face), see Standard Industry Gable End Details as applicable, or consult qualified building designer as per ANSI/TPI 1.
 - 3) TCLL: ASCE 7-16; Pf=25.0 psf (Lum DOL = 1.15 Plate DOL = 1.15); Is=1.0; Rough Cat B; Partially Exp.; Ce=1.0; Cs=1.00; Ct=1.10
 - 4) Unbalanced snow loads have been considered for this design.
 - 5) This truss has been designed for greater of min roof live load of 20.0 psf or 2.00 times flat roof load of 25.0 psf on overhangs non-concurrent with other live loads.
 - 6) All plates are 1.5x4 MT20 unless otherwise indicated.
 - 7) Gable requires continuous bottom chord bearing.
 - 8) Gable studs spaced at 2-0-0 oc.
 - 9) This truss has been designed for a 10.0 psf bottom chord live load nonconcurrent with any other live loads.
 - 10) * This truss has been designed for a live load of 20.0psf on the bottom chord in all areas where a rectangle 3-6-0 tall by 2-0-0 wide will fit between the bottom chord and any other members, with BCDL = 10.0psf.
 - 11) Provide mechanical connection (by others) of truss to bearing plate capable of withstanding 100 lb uplift at joint(s) J, V except (jt=lb) I=1199, B=704, T=2021, N=900.
 - 12) This truss is designed in accordance with the 2018 International Building Code section 2306.1 and referenced standard ANSI/TPI



September 12, 2024

Continued on page 2

WARNING - Verify design parameters and READ NOTES ON THIS AND INCLUDED MITEK REFERENCE PAGE MII-7473 rev. 6/30/2020 BEFORE USE.
 Design valid for use only with MiTek® connectors. This design is based only upon parameters shown, and is for an individual building component, not a truss system. Before use, the building designer must verify the applicability of design parameters and properly incorporate this design into the overall building design. Bracing indicated is to prevent buckling of individual truss web and/or chord members only. Additional temporary and permanent bracing is always required for stability and to prevent collapse with possible personal injury and property damage. For general guidance regarding the fabrication, storage, delivery, erection and bracing of trusses and truss systems, see **ANSI/TPI1 Quality Criteria, DSB-89 and BCSI Building Component Safety Information** available from Truss Plate Institute, 2670 Crain Highway, Suite 203 Waldorf, MD 20601

240 Stirling Crescent
Bradford, ON. L3Z 4L5

Job	Truss	Truss Type	Qty	Ply	Buildings A-H
N0653A	T3	GABLE	9	1	U1530874

Alliance Truss (CA), Abbotsford, BC - V2S 7P6,

8.820 s Aug 30 2024 MiTek Industries, Inc. Thu Sep 12 02:48:29 2024 Page 2
ID:hFyjDMxrTsEK_kgkR0vWWVzF1gc-z71fkhLga?jDJG5?RDudQxTP77y2me8xZlvXd3yeVqm

NOTES-

- 13) This truss has been designed for a total drag load of 240 plf. Lumber DOL=(1.33) Plate grip DOL=(1.33) Connect truss to resist drag loads along bottom chord from 0-0-0 to 26-10-0 for 240.0 plf.
- 14) No notches allowed in overhang and 10408 from left end and 0 from right end or 12" along rake from scarf, whichever is larger. Minimum 1.5x4 tie plates required at 2-0-0 o.c. maximum between the stacking chords. For edge-wise notching, provide at least one tie plate between each notch.



WARNING - Verify design parameters and READ NOTES ON THIS AND INCLUDED MITEK REFERENCE PAGE MII-7473 rev. 6/30/2020 BEFORE USE.

Design valid for use only with MiTek® connectors. This design is based only upon parameters shown, and is for an individual building component, not a truss system. Before use, the building designer must verify the applicability of design parameters and properly incorporate this design into the overall building design. Bracing indicated is to prevent buckling of individual truss web and/or chord members only. Additional temporary and permanent bracing is always required for stability and to prevent collapse with possible personal injury and property damage. For general guidance regarding the fabrication, storage, delivery, erection and bracing of trusses and truss systems, see

Safety Information available from Truss Plate Institute, 2670 Crain Highway, Suite 203 Waldorf, MD 20601



240 Stirling Crescent
Bradford, ON. L3Z 4L5

Job	Truss	Truss Type	Qty	Ply	Buildings A-H	U1530803
N0653A	U1	GABLE	10	1		

Alliance Truss (CA), Abbotsford, BC - V2S 7P6, 8.630 s Jul 12 2024 MiTek Industries, Inc. Thu Sep 12 02:47:46 2024 Page 1

ID:hFyjDMxrTsEK_kgkR0vWWVzFfgc-RfC?PsB70Hq3NSgPqnL8w3ulTXbGKWrCDoi7J4zJC?f

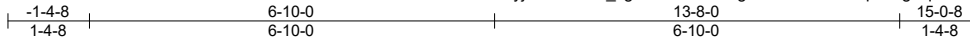

4x5 ||

Scale = 1:38.9

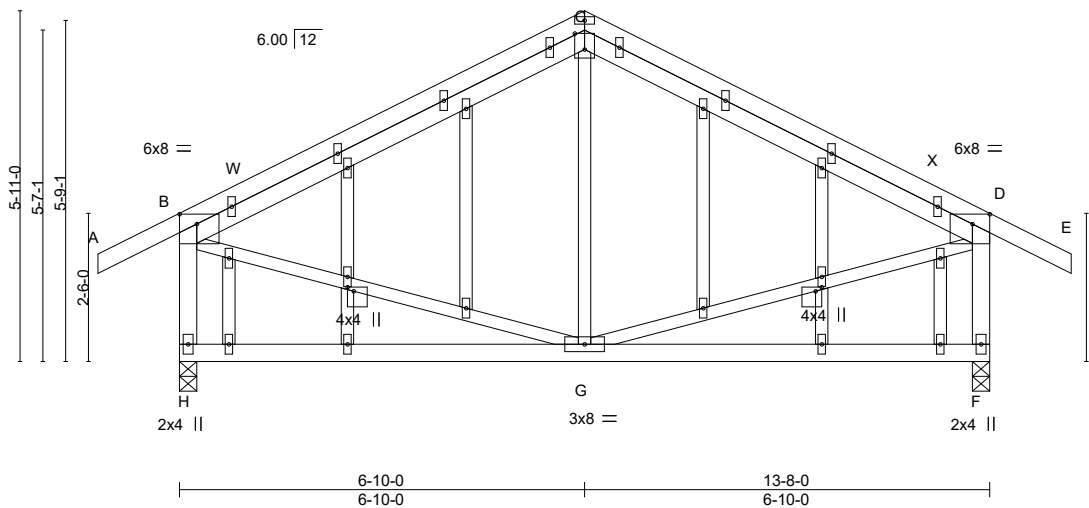

Plate Offsets (X,Y)-- [B:0-3-8,0-2-0], [C:0-3-4,0-2-0], [D:0-3-8,0-2-0], [K:0-0-13,0-1-4], [T:0-0-13,0-1-4]

LOADING (psf)	SPACING-	CSI.	DEFL.	in (loc)	l/defl	L/d	PLATES	GRIP
TCLL 25.0 (Roof Snow=25.0)	2-0-0 Plate Grip DOL 1.15 Lumber DOL 1.15	TC 0.81 BC 0.33 WB 0.14 Matrix-MS	Vert(LL) -0.04 Vert(CT) -0.09 Horz(CT) 0.00 Wind(LL) 0.00	F-G F-G F G	>999 >999 n/a >999	360 240 n/a 240	MT20	197/144
TCDL 12.0	Rep Stress Incr YES Code IBC2018/TPI2014						Weight: 86 lb	FT = 20%
BCLL 0.0 *								
BCDL 10.0								

LUMBER-

TOP CHORD 2x4 SPF No.2
 BOT CHORD 2x4 SPF No.2
 WEBS 2x3 SPF No.2 *Except*
 B-H,D-F: 2x4 SPF No.2
 OTHERS 2x3 SPF No.2

BRACING-

TOP CHORD Structural wood sheathing directly applied or 3-11-6 oc purlins, except end verticals.
 BOT CHORD Rigid ceiling directly applied or 10-0-0 oc bracing.

REACTIONS.

(size) H=0-3-8, F=0-3-8
 Max Horz H=-95(LC 8)
 Max Uplift H=-77(LC 10), F=-77(LC 11)
 Max Grav H=836(LC 17), F=836(LC 18)

FORCES. (lb) - Max. Comp./Max. Ten. - All forces 250 (lb) or less except when shown.

TOP CHORD B-C=-643/66, C-D=-643/66, B-H=-771/103, D-F=-771/103
 WEBS B-G=0/413, D-G=0/413

NOTES-

- 1) Wind: ASCE 7-16; Vult=115mph (3-second gust) Vasd=91mph; TCDL=4.2psf; BCDL=5.0psf; h=30ft; Ke=1.00; Cat. II; Exp B; Enclosed; MWFRS (envelope) gable end zone; cantilever left and right exposed; end vertical left and right exposed; Lumber DOL=1.33 plate grip DOL=1.33
- 2) Truss designed for wind loads in the plane of the truss only. For studs exposed to wind (normal to the face), see Standard Industry Gable End Details as applicable, or consult qualified building designer as per ANSI/TPI 1.
- 3) TCLL: ASCE 7-16; Pf=25.0 psf (Lum DOL=1.15 Plate DOL=1.15); Is=1.0; Rough Cat B; Partially Exp.; Ce=1.0; Cs=1.00; Ct=1.10
- 4) Unbalanced snow loads have been considered for this design.
- 5) This truss has been designed for greater of min roof live load of 18.0 psf or 2.00 times flat roof load of 25.0 psf on overhangs non-concurrent with other live loads.
- 6) All plates are 1.5x4 MT20 unless otherwise indicated.
- 7) Gable studs spaced at 2-0-0 oc.
- 8) This truss has been designed for a 10.0 psf bottom chord live load nonconcurrent with any other live loads.
- 9) * This truss has been designed for a live load of 20.0psf on the bottom chord in all areas where a rectangle 3-6-0 tall by 2-0-0 wide will fit between the bottom chord and any other members.
- 10) Provide mechanical connection (by others) of truss to bearing plate capable of withstanding 100 lb uplift at joint(s) H, F.
- 11) This truss is designed in accordance with the 2018 International Building Code section 2306.1 and referenced standard ANSI/TPI 1.
- 12) No notches allowed in overhang and 10408 from left end and 10408 from right end or 12" along rake from scarf, whichever is larger. Minimum 1.5x4 tie plates required at 2-0-0 o.c. maximum between the stacking chords. For edge-wise notching, provide at least one tie plate between each notch.



September 12, 2024

WARNING - Verify design parameters and READ NOTES ON THIS AND INCLUDED MITEK REFERENCE PAGE MII-7473 rev. 6/30/2020 BEFORE USE.

Design valid for use only with MiTek® connectors. This design is based only upon parameters shown, and is for an individual building component, not a truss system. Before use, the building designer must verify the applicability of design parameters and properly incorporate this design into the overall building design. Bracing indicated is to prevent buckling of individual truss web and/or chord members only. Additional temporary and permanent bracing is always required for stability and to prevent collapse with possible personal injury and property damage. For general guidance regarding the fabrication, storage, delivery, erection and bracing of trusses and truss systems, see

Safety Information available from Truss Plate Institute, 2670 Crain Highway, Suite 203 Waldorf, MD 20601

ANSI/TPI1 Quality Criteria, DSB-89 and BCSI Building Component



240 Stirling Crescent
 Bradford, ON. L3Z 4L5

Job	Truss	Truss Type	Qty	Ply	Buildings A-H
N0653A	U2	GABLE	10	1	U1530804

Alliance Truss (CA), Abbotsford, BC - V2S 7P6,

8.630 s Jul 12 2024 MiTek Industries, Inc. Thu Sep 12 02:47:47 2024 Page 1

ID:hFyjDMxrTsEK_kgkR0vWWVzFfgc-RfC?PsB70Hq3NSgPqnL8w3ulTXbGKWrCDoi7JzJC?f



3x4

Scale = 1:52.2

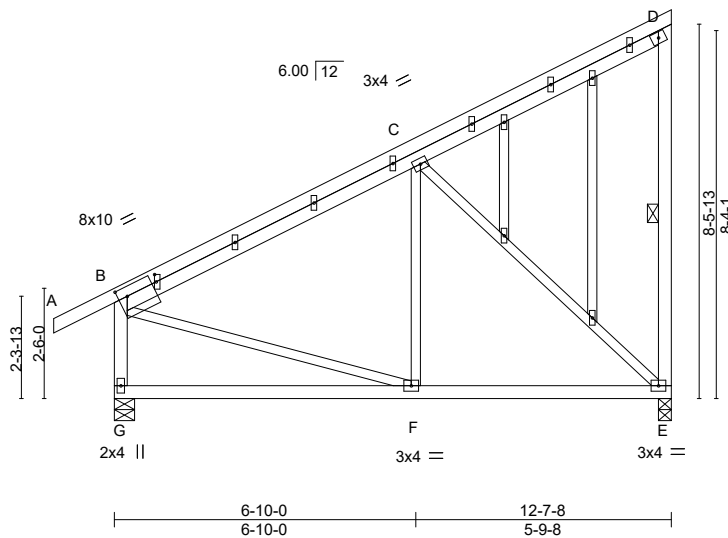

Plate Offsets (X,Y)-- [B:0-2-8,0-2-8], [B:0-2-0,0-0-7]

LOADING (psf)		SPACING-		CSI.		DEFL.		PLATES		GRIP	
TCLL	25.0	Plate Grip DOL	1.15	TC	0.63	Vert(LL)	-0.05 F-G >999 360	MT20	197/144		
(Roof Snow=25.0)		Lumber DOL	1.15	BC	0.33	Vert(CT)	-0.10 F-G >999 240				
TCDL	12.0	Rep Stress Incr	YES	WB	0.92	Horz(CT)	0.01 E n/a n/a				
BCLL	0.0 *	Code IBC2018/TPI2014		Matrix-MS		Wind(LL)	-0.02 E-F >999 240			Weight: 82 lb	FT = 20%
BCDL	10.0										

LUMBER-

TOP CHORD 2x4 SPF No.2
 BOT CHORD 2x4 SPF No.2
 WEBS 2x3 SPF No.2 *Except*
 D-E,B-G: 2x4 SPF No.2
 OTHERS 2x3 SPF No.2

BRACING-

TOP CHORD Structural wood sheathing directly applied or 6-0-0 oc purlins, except end verticals.
 BOT CHORD Rigid ceiling directly applied or 6-0-0 oc bracing.
 WEBS 1 Row at midpt D-E

REACTIONS.

(size) G=0-5-8, E=0-3-8
 Max Horz G=253(LC 9)
 Max Uplift G=-65(LC 10), E=-107(LC 10)
 Max Grav G=749(LC 17), E=739(LC 17)

FORCES. (lb) - Max. Comp./Max. Ten. - All forces 250 (lb) or less except when shown.

TOP CHORD B-C=-621/41, D-E=-262/51, B-G=-685/95
 BOT CHORD E-F=-101/474
 WEBS C-E=-631/138, B-F=0/431

NOTES-

- 1) Wind: ASCE 7-16; Vult=115mph (3-second gust) Vasd=91mph; TCDL=4.2psf; BCDL=5.0psf; h=30ft; Ke=1.00; Cat. II; Exp B; Enclosed; MWFRS (envelope) gable end zone; cantilever left and right exposed ; end vertical left and right exposed; Lumber DOL=1.33 plate grip DOL=1.33
- 2) Truss designed for wind loads in the plane of the truss only. For studs exposed to wind (normal to the face), see Standard Industry Gable End Details as applicable, or consult qualified building designer as per ANSI/TPI 1.
- 3) TCLL: ASCE 7-16; Pf=25.0 psf (Lum DOL=1.15 Plate DOL=1.15); Is=1.0; Rough Cat B; Partially Exp.; Ce=1.0; Cs=1.00; Ct=1.10
- 4) Unbalanced snow loads have been considered for this design.
- 5) This truss has been designed for greater of min roof live load of 18.0 psf or 2.00 times flat roof load of 25.0 psf on overhangs non-concurrent with other live loads.
- 6) All plates are 1.5x4 MT20 unless otherwise indicated.
- 7) Gable studs spaced at 2-0-0 oc.
- 8) This truss has been designed for a 10.0 psf bottom chord live load nonconcurrent with any other live loads.
- 9) * This truss has been designed for a live load of 20.0psf on the bottom chord in all areas where a rectangle 3-6-0 tall by 2-0-0 wide will fit between the bottom chord and any other members.
- 10) Provide mechanical connection (by others) of truss to bearing plate capable of withstanding 100 lb uplift at joint(s) G except (jt=lb) E=107.
- 11) This truss is designed in accordance with the 2018 International Building Code section 2306.1 and referenced standard ANSI/TPI 1.
- 12) No notches allowed in overhang and 10408 from left end and 0 from right end or 12" along rake from scarf, whichever is larger. Minimum 1.5x4 tie plates required at 2-0-0 o.c. maximum between the stacking chords. For edge-wise notching, provide at least one tie plate between each notch.



September 12,2024

WARNING - Verify design parameters and READ NOTES ON THIS AND INCLUDED MITEK REFERENCE PAGE MII-7473 rev. 6/30/2020 BEFORE USE.

Design valid for use only with MiTek® connectors. This design is based only upon parameters shown, and is for an individual building component, not a truss system. Before use, the building designer must verify the applicability of design parameters and properly incorporate this design into the overall building design. Bracing indicated is to prevent buckling of individual truss web and/or chord members only. Additional temporary and permanent bracing is always required for stability and to prevent collapse with possible personal injury and property damage. For general guidance regarding the fabrication, storage, delivery, erection and bracing of trusses and truss systems, see **ANSI/TPI1 Quality Criteria, DSB-89 and BCSI Building Component Safety Information** available from Truss Plate Institute, 2670 Crain Highway, Suite 203 Waldorf, MD 20601



240 Stirling Crescent
 Bradford, ON. L3Z 4L5

Job	Truss	Truss Type	Qty	Ply	Buildings A-H	U1530805
N0653A	U3	Monopitch	20	1		

Alliance Truss (CA), Abbotsford, BC - V2S 7P6,

8.630 s Jul 12 2024 MiTek Industries, Inc. Thu Sep 12 02:47:48 2024 Page 1

ID:hFyjDMxrTsEK_kgkR0vWWVzFfgc-RfC?PsB70Hq3NSgPqnL8w3ulTXbGKWrCDoi7J4zJC?f

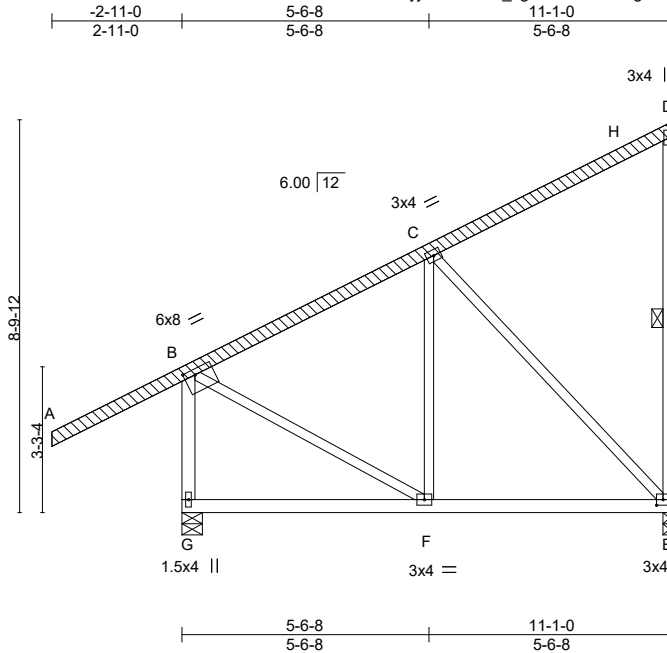

Plate Offsets (X,Y)-- [B:0-3-0,0-1-8], [E:0-1-12,0-1-8]

LOADING (psf)	SPACING-	CSI.	DEFL.	in (loc)	l/defl	L/d	PLATES	GRIP
TCLL 25.0 (Roof Snow=25.0)	2-0-0 Plate Grip DOL 1.15	TC 0.63	Vert(LL)	-0.02 E-F	>999	360	MT20	197/144
TCDL 12.0	Lumber DOL 1.15	BC 0.25	Vert(CT)	-0.04 E-F	>999	240		
BCLL 0.0 *	Rep Stress Incr YES	WB 0.67	Horz(CT)	-0.00 E	n/a	n/a		
BCDL 10.0	Code IBC2018/TPI2014	Matrix-MS	Wind(LL)	-0.02 E-F	>999	240	Weight: 77 lb	FT = 20%

LUMBER-
 TOP CHORD 2x4 SPF No.2
 BOT CHORD 2x4 SPF No.2
 WEBS 2x3 SPF No.2 *Except*
 D-E,B-G: 2x4 SPF No.2
 OTHERS 2x4 SPF No.2
 LBR SCAB A-D 2x4 SPF No.2 one side

BRACING-
 TOP CHORD Structural wood sheathing directly applied or 6-0-0 oc purlins, except end verticals.
 BOT CHORD Rigid ceiling directly applied or 6-0-0 oc bracing.
 WEBS 1 Row at midpt D-E

REACTIONS. (size) G=0-5-8, E=0-3-8
 Max Horz G=274(LC 7)
 Max Uplift G=-83(LC 10), E=-103(LC 7)
 Max Grav G=817(LC 17), E=629(LC 17)

FORCES. (lb) - Max. Comp./Max. Ten. - All forces 250 (lb) or less except when shown.
 TOP CHORD B-C=-439/35, D-E=-260/51, B-G=-772/107
 BOT CHORD F-G=-256/88, E-F=-114/311
 WEBS C-E=-443/116, B-F=0/379

- NOTES-**
- Attached 15-9-9 scab A to D, front face(s) 2x4 SPF No.2 with 1 row(s) of 10d (0.131"x3") nails spaced 9" o.c. except : starting at 2-5-1 from end at joint A, nail 1 row(s) at 4" o.c. for 2-0-0; starting at 8-5-8 from end at joint A, nail 1 row(s) at 7" o.c. for 2-0-0; starting at 13-5-14 from end at joint A, nail 1 row(s) at 7" o.c. for 2-0-0.
 - Wind: ASCE 7-16; Vult=115mph (3-second gust) Vasd=91mph; TC DL=4.2psf; BCDL=5.0psf; h=30ft; Ke=1.00; Cat. II; Exp B; Enclosed; MWFRS (envelope) gable end zone; cantilever left and right exposed ; end vertical left and right exposed; Lumber DOL=1.33 plate grip DOL=1.33
 - TCLL: ASCE 7-16; Pf=25.0 psf (Lum DOL=1.15 Plate DOL=1.15); Is=1.0; Rough Cat B; Partially Exp.; Ce=1.0; Cs=1.0; Ct=1.10
 - Unbalanced snow loads have been considered for this design.
 - This truss has been designed for greater of min roof live load of 18.0 psf or 2.00 times flat roof load of 25.0 psf on overhangs non-concurrent with other live loads.
 - This truss has been designed for a 10.0 psf bottom chord live load nonconcurrent with any other live loads.
 - * This truss has been designed for a live load of 20.0psf on the bottom chord in all areas where a rectangle 3-6-0 tall by 2-0-0 wide will fit between the bottom chord and any other members.
 - Provide mechanical connection (by others) of truss to bearing plate capable of withstanding 100 lb uplift at joint(s) G except (jt=lb) E=103.
 - This truss is designed in accordance with the 2018 International Building Code section 2306.1 and referenced standard ANSI/TPI 1.



September 12, 2024

WARNING - Verify design parameters and READ NOTES ON THIS AND INCLUDED MITEK REFERENCE PAGE MII-7473 rev. 6/30/2020 BEFORE USE.

Design valid for use only with MiTek® connectors. This design is based only upon parameters shown, and is for an individual building component, not a truss system. Before use, the building designer must verify the applicability of design parameters and properly incorporate this design into the overall building design. Bracing indicated is to prevent buckling of individual truss web and/or chord members only. Additional temporary and permanent bracing is always required for stability and to prevent collapse with possible personal injury and property damage. For general guidance regarding the fabrication, storage, delivery, erection and bracing of trusses and truss systems, see

Safety Information available from Truss Plate Institute, 2670 Crain Highway, Suite 203 Waldorf, MD 20601



240 Stirling Crescent
 Bradford, ON. L3Z 4L5

Job N0653A	Truss VG1	Truss Type GABLE	Qty 2	Ply 1	Buildings A-H U1530875
---------------	--------------	---------------------	----------	----------	---------------------------

Alliance Truss (CA), Abbotsford, BC - V2S 7P6,

8.820 s Aug 30 2024 MiTek Industries, Inc. Thu Sep 12 02:48:29 2024 Page 1

ID:hFyjDMxrTsEK_kgkR0vWVvzFlgc-z71fkhLga?jDJG5?RDudQxTXZ739mqtxZlvXd3yeVqm

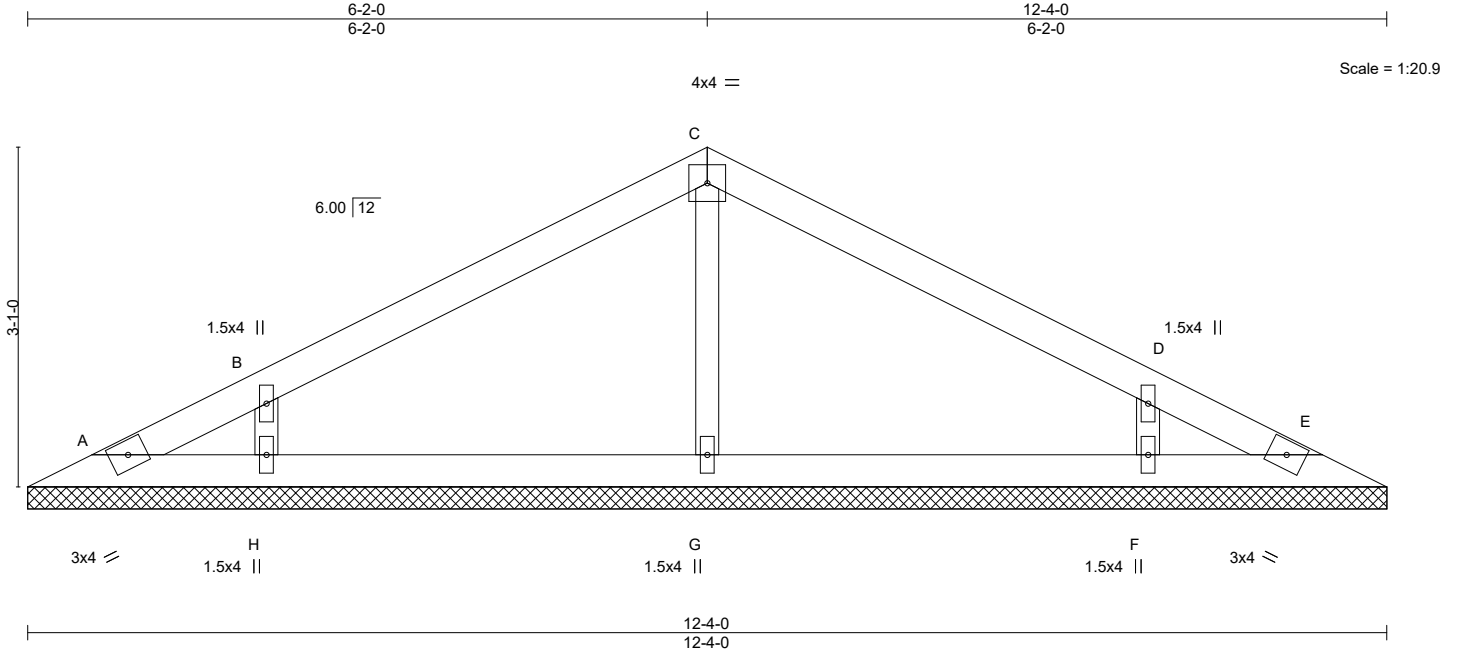

LOADING (psf)	SPACING-	CSI.	DEFL.	PLATES	GRIP
TCLL 25.0 (Roof Snow=25.0)	2-0-0 Plate Grip DOL 1.15 Lumber DOL 1.15	TC 0.28 BC 0.10 WB 0.08 Matrix-S	in (loc) l/defl L/d Vert(LL) n/a - n/a 999 Vert(CT) n/a - n/a 999 Horz(CT) 0.00 E n/a n/a	MT20	197/144
TCDL 12.0 BCLL 0.0 * BCDL 10.0	Rep Stress Incr YES Code IBC2018/TPI2014			Weight: 31 lb	FT = 20%

LUMBER-

TOP CHORD 2x4 SPF No.2
BOT CHORD 2x4 SPF No.2
OTHERS 2x3 SPF No.2

BRACING-

TOP CHORD Structural wood sheathing directly applied or 6-0-0 oc purlins.
BOT CHORD Rigid ceiling directly applied or 10-0-0 oc bracing.

REACTIONS.

All bearings 12-4-0.
(lb) - Max Horz A=-36(LC 11)
Max Uplift All uplift 100 lb or less at joint(s) A, H, F
Max Grav All reactions 250 lb or less at joint(s) A, E except G=332(LC 16), H=495(LC 16), F=495(LC 17)

FORCES. (lb) - Max. Comp./Max. Ten. - All forces 250 (lb) or less except when shown.
WEBS B-H=-438/114, D-F=-438/114

NOTES-

- 1) Wind: ASCE 7-16; Vult=115mph (3-second gust) Vasd=91mph; TCDL=4.2psf; BCDL=5.0psf; h=30ft; Ke=1.00; Cat. II; Exp B; Enclosed; MWFRS (envelope) gable end zone; cantilever left and right exposed; end vertical left and right exposed; Lumber DOL=1.33 plate grip DOL=1.33
- 2) TCLL: ASCE 7-16; Pf=25.0 psf (Lum DOL = 1.15 Plate DOL = 1.15); Is=1.0; Rough Cat B; Partially Exp.; Ce=1.0; Cs=1.00; Ct=1.10
- 3) Unbalanced snow loads have been considered for this design.
- 4) Gable requires continuous bottom chord bearing.
- 5) This truss has been designed for a 10.0 psf bottom chord live load nonconcurrent with any other live loads.
- 6) * This truss has been designed for a live load of 20.0psf on the bottom chord in all areas where a rectangle 3-6-0 tall by 2-0-0 wide will fit between the bottom chord and any other members.
- 7) Provide mechanical connection (by others) of truss to bearing plate capable of withstanding 100 lb uplift at joint(s) A, H, F.
- 8) This truss is designed in accordance with the 2018 International Building Code section 2306.1 and referenced standard ANSI/TPI 1.



September 12, 2024

WARNING - Verify design parameters and READ NOTES ON THIS AND INCLUDED MITEK REFERENCE PAGE MII-7473 rev. 6/30/2020 BEFORE USE.

Design valid for use only with MiTek® connectors. This design is based only upon parameters shown, and is for an individual building component, not a truss system. Before use, the building designer must verify the applicability of design parameters and properly incorporate this design into the overall building design. Bracing indicated is to prevent buckling of individual truss web and/or chord members only. Additional temporary and permanent bracing is always required for stability and to prevent collapse with possible personal injury and property damage. For general guidance regarding the fabrication, storage, delivery, erection and bracing of trusses and truss systems, see

ANSI/TPI1 Quality Criteria, DSB-89 and BCSI Building Component

Safety Information available from Truss Plate Institute, 2670 Crain Highway, Suite 203 Waldorf, MD 20601



240 Stirling Crescent
Bradford, ON. L3Z 4L5

Job N0653A	Truss VG2	Truss Type GABLE	Qty 2	Ply 1	Buildings A-H U1530876
---------------	--------------	---------------------	----------	----------	---------------------------

Alliance Truss (CA), Abbotsford, BC - V2S 7P6,

8.820 s Aug 30 2024 MiTek Industries, Inc. Thu Sep 12 02:48:30 2024 Page 1

ID:hFyjDMxrTsEK_kgkR0vWWVzF1gc-RKb1x1MILr4wQgB?wPsz9?g2WM3VIK4oPf49VyeVql

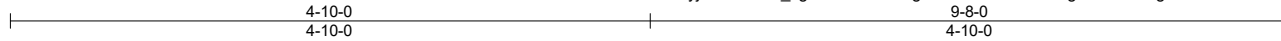

Scale = 1:17.4

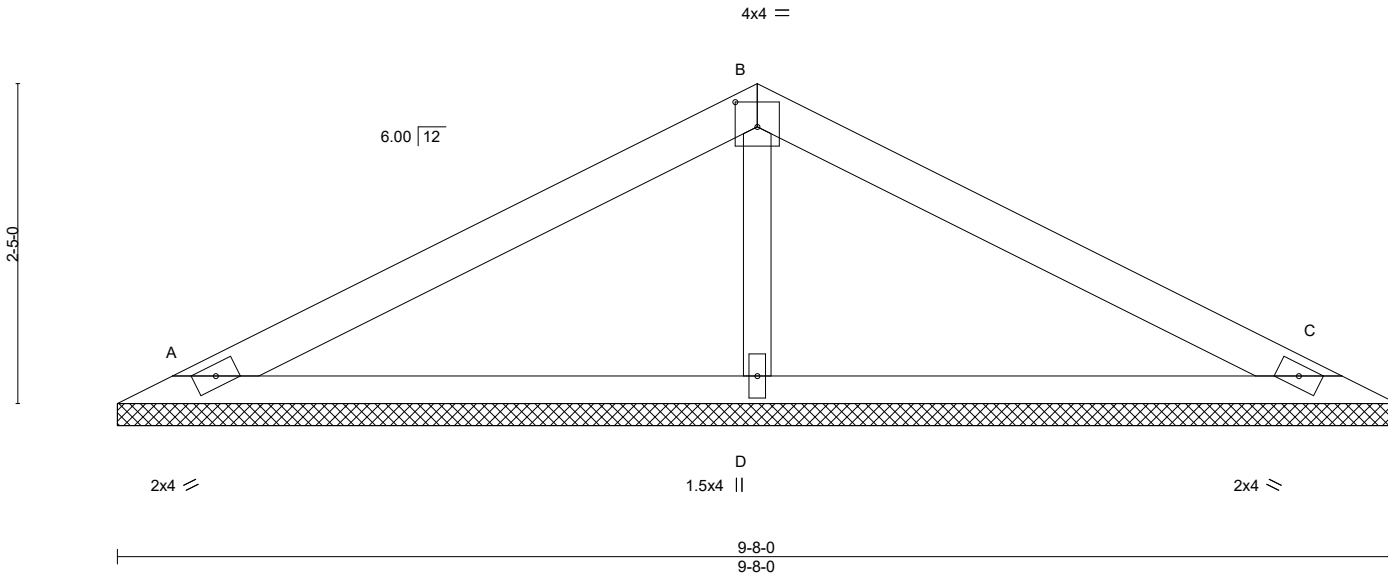

Plate Offsets (X,Y)-- [B:0-2-0,0-2-4]

LOADING (psf)	SPACING-	CSI.	DEFL.	in (loc)	l/defl	L/d	PLATES	GRIP
TCLL 25.0 (Roof Snow=25.0)	2-0-0 Plate Grip DOL 1.15 Lumber DOL 1.15	TC 0.43 BC 0.32 WB 0.00 Matrix-S	Vert(LL) Vert(CT) Horz(CT)	n/a n/a 0.01	- - C	n/a n/a n/a	MT20	197/144
TCDL 12.0	Rep Stress Incr YES Code IBC2018/TPI2014						Weight: 21 lb	FT = 20%
BCLL 0.0 *								
BCDL 10.0								

LUMBER-
 TOP CHORD 2x4 SPF No.2
 BOT CHORD 2x3 SPF No.2
 OTHERS 2x3 SPF No.2

BRACING-
 TOP CHORD Structural wood sheathing directly applied or 6-0-0 oc purlins.
 BOT CHORD Rigid ceiling directly applied or 10-0-0 oc bracing.

REACTIONS. (size) A=9-8-0, C=9-8-0, D=9-8-0
 Max Horz A=28(LC 14)
 Max Uplift A=-56(LC 10), C=-56(LC 11)
 Max Grav A=423(LC 16), C=423(LC 17), D=206(LC 5)

FORCES. (lb) - Max. Comp./Max. Ten. - All forces 250 (lb) or less except when shown.
 TOP CHORD A-B=-474/94, B-C=-474/94
 BOT CHORD A-D=-60/354, C-D=-60/354

- NOTES-**
- 1) Wind: ASCE 7-16; Vult=115mph (3-second gust) Vasd=91mph; TCDL=4.2psf; BCDL=5.0psf; h=30ft; Ke=1.00; Cat. II; Exp B; Enclosed; MWFRS (envelope) gable end zone; cantilever left and right exposed ; end vertical left and right exposed; Lumber DOL=1.33 plate grip DOL=1.33
 - 2) TCLL: ASCE 7-16; Pf=25.0 psf (Lum DOL = 1.15 Plate DOL = 1.15); Is=1.0; Rough Cat B; Partially Exp.; Ce=1.0; Cs=1.00; Ct=1.10
 - 3) Unbalanced snow loads have been considered for this design.
 - 4) Gable requires continuous bottom chord bearing.
 - 5) This truss has been designed for a 10.0 psf bottom chord live load nonconcurrent with any other live loads.
 - 6) * This truss has been designed for a live load of 20.0psf on the bottom chord in all areas where a rectangle 3-6-0 tall by 2-0-0 wide will fit between the bottom chord and any other members.
 - 7) Provide mechanical connection (by others) of truss to bearing plate capable of withstanding 100 lb uplift at joint(s) A, C.
 - 8) This truss is designed in accordance with the 2018 International Building Code section 2306.1 and referenced standard ANSI/TPI 1.



September 12, 2024

WARNING - Verify design parameters and READ NOTES ON THIS AND INCLUDED MITEK REFERENCE PAGE MII-7473 rev. 6/30/2020 BEFORE USE.

Design valid for use only with MiTek® connectors. This design is based only upon parameters shown, and is for an individual building component, not a truss system. Before use, the building designer must verify the applicability of design parameters and properly incorporate this design into the overall building design. Bracing indicated is to prevent buckling of individual truss web and/or chord members only. Additional temporary and permanent bracing is always required for stability and to prevent collapse with possible personal injury and property damage. For general guidance regarding the fabrication, storage, delivery, erection and bracing of trusses and truss systems, see

Safety Information available from Truss Plate Institute, 2670 Crain Highway, Suite 203 Waldorf, MD 20601

ANSI/TPI1 Quality Criteria, DSB-89 and BCSI Building Component



240 Stirling Crescent
 Bradford, ON. L3Z 4L5

Job	Truss	Truss Type	Qty	Ply	Buildings A-H	U1530877
N0653A	VG3	Valley	2	1		

Alliance Truss (CA), Abbotsford, BC - V2S 7P6, 8.820 s Aug 30 2024 MiTek Industries, Inc. Thu Sep 12 02:48:30 2024 Page 1

ID:hFyjDMxrTsEK_kgkR0vWWVzFlgc-RKb1x1MLlr4wQgB?wPsz9?j6WOjVIn4oPf49VyeVql

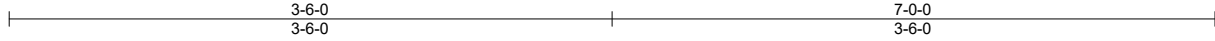

Scale = 1:13.4

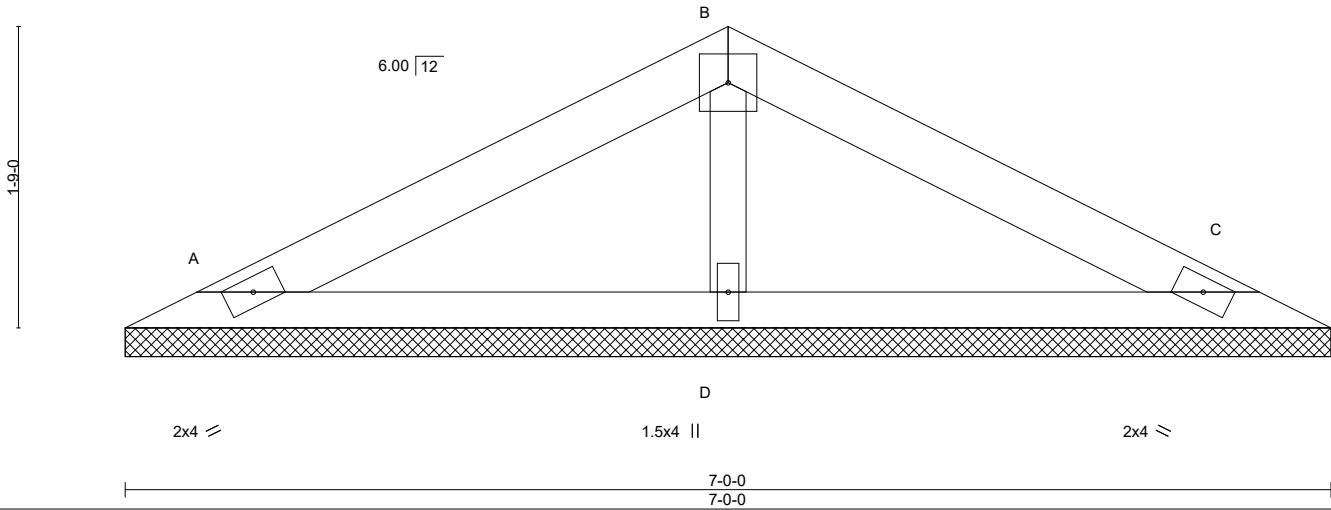

LOADING (psf)	SPACING-	CSI.	DEFL.	in	(loc)	l/defl	L/d	PLATES	GRIP
TCLL 25.0	2-0-0	TC 0.23	Vert(LL)	n/a	-	n/a	999	MT20	197/144
(Roof Snow=25.0)	Plate Grip DOL 1.15	BC 0.15	Vert(CT)	n/a	-	n/a	999		
TCDL 12.0	Lumber DOL 1.15	WB 0.04	Horz(CT)	0.00	C	n/a	n/a		
BCLL 0.0 *	Rep Stress Incr YES	Matrix-P							
BCDL 10.0	Code IBC2018/TPI2014							Weight: 15 lb	FT = 20%

LUMBER-

TOP CHORD 2x4 SPF No.2
 BOT CHORD 2x3 SPF No.2
 OTHERS 2x3 SPF No.2

BRACING-

TOP CHORD Structural wood sheathing directly applied or 6-0-0 oc purlins.
 BOT CHORD Rigid ceiling directly applied or 10-0-0 oc bracing.

REACTIONS.

(size) A=7-0-0, C=7-0-0, D=7-0-0
 Max Horz A=19(LC 10)
 Max Uplift A=-23(LC 10), C=-27(LC 11)
 Max Grav A=188(LC 16), C=188(LC 17), D=269(LC 1)

FORCES. (lb) - Max. Comp./Max. Ten. - All forces 250 (lb) or less except when shown.

NOTES-

- 1) Wind: ASCE 7-16; Vult=115mph (3-second gust) Vasd=91mph; TCDL=4.2psf; BCDL=5.0psf; h=30ft; Ke=1.00; Cat. II; Exp B; Enclosed; MWFRS (envelope) gable end zone; cantilever left and right exposed; end vertical left and right exposed; Lumber DOL=1.33 plate grip DOL=1.33
- 2) TCLL: ASCE 7-16; Pf=25.0 psf (Lum DOL = 1.15 Plate DOL = 1.15); Is=1.0; Rough Cat B; Partially Exp.; Ce=1.0; Cs=1.00; Ct=1.10
- 3) Unbalanced snow loads have been considered for this design.
- 4) Gable requires continuous bottom chord bearing.
- 5) This truss has been designed for a 10.0 psf bottom chord live load nonconcurrent with any other live loads.
- 6) * This truss has been designed for a live load of 20.0psf on the bottom chord in all areas where a rectangle 3-6-0 tall by 2-0-0 wide will fit between the bottom chord and any other members.
- 7) Provide mechanical connection (by others) of truss to bearing plate capable of withstanding 100 lb uplift at joint(s) A, C.
- 8) This truss is designed in accordance with the 2018 International Building Code section 2306.1 and referenced standard ANSI/TPI 1.



September 12, 2024

WARNING - Verify design parameters and READ NOTES ON THIS AND INCLUDED MITEK REFERENCE PAGE MII-7473 rev. 6/30/2020 BEFORE USE.

Design valid for use only with MiTek® connectors. This design is based only upon parameters shown, and is for an individual building component, not a truss system. Before use, the building designer must verify the applicability of design parameters and properly incorporate this design into the overall building design. Bracing indicated is to prevent buckling of individual truss web and/or chord members only. Additional temporary and permanent bracing is always required for stability and to prevent collapse with possible personal injury and property damage. For general guidance regarding the fabrication, storage, delivery, erection and bracing of trusses and truss systems, see

Safety Information available from Truss Plate Institute, 2670 Crain Highway, Suite 203 Waldorf, MD 20601



240 Stirling Crescent
 Bradford, ON. L3Z 4L5

Job	Truss	Truss Type	Qty	Ply	Buildings A-H	U1530878
N0653A	VG4	Valley	2	1		

Alliance Truss (CA), Abbotsford, BC - V2S 7P6,

8.820 s Aug 30 2024 MiTek Industries, Inc. Thu Sep 12 02:48:30 2024 Page 1

ID:hFyjDMxrTsEK_kgkR0vWWVzFfgc-RKb1x1MILlr4wQgB?wPsz9?mpWNUVJK4oPf49VyeVql

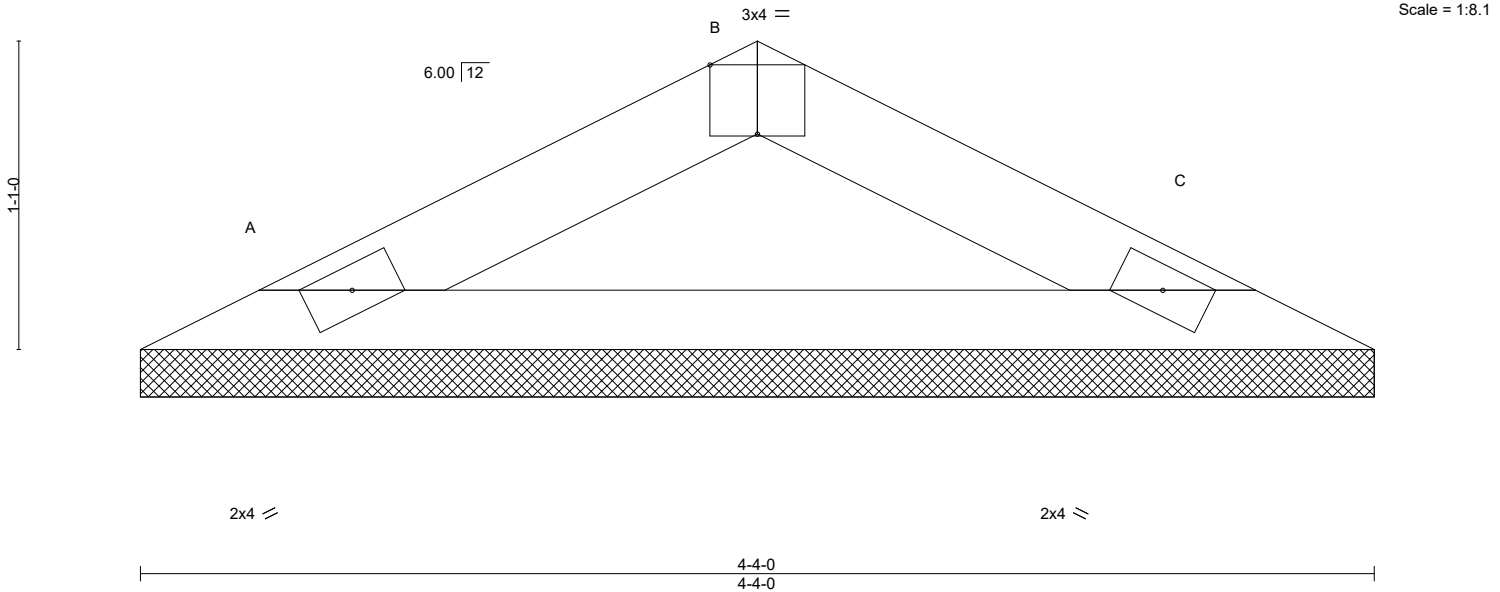
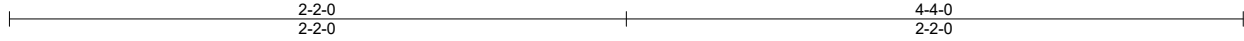

Plate Offsets (X,Y)-- [B:0-2-0,Edge]

LOADING (psf)		SPACING-		CSI.		DEFL.				PLATES		GRIP	
TCLL	25.0	Plate Grip DOL	1.15	TC	0.06	Vert(LL)	n/a	-	n/a	999	MT20	197/144	
(Roof Snow=25.0)		Lumber DOL	1.15	BC	0.23	Vert(CT)	n/a	-	n/a	999			
TCDL	12.0	Rep Stress Incr	YES	WB	0.00	Horz(CT)	0.00	C	n/a	n/a			
BCLL	0.0 *	Code IBC2018/TPI2014		Matrix-P									
BCDL	10.0										Weight: 8 lb	FT = 20%	

LUMBER-

TOP CHORD 2x4 SPF No.2
 BOT CHORD 2x3 SPF No.2

BRACING-

TOP CHORD Structural wood sheathing directly applied or 4-4-0 oc purlins.
 BOT CHORD Rigid ceiling directly applied or 10-0-0 oc bracing.

REACTIONS.

(size) A=4-4-0, C=4-4-0
 Max Horz A=11(LC 10)
 Max Uplift A=-13(LC 10), C=-13(LC 11)
 Max Grav A=166(LC 16), C=166(LC 17)

FORCES. (lb) - Max. Comp./Max. Ten. - All forces 250 (lb) or less except when shown.

NOTES-

- 1) Wind: ASCE 7-16; Vult=115mph (3-second gust) Vasd=91mph; TCDL=4.2psf; BCDL=5.0psf; h=30ft; Ke=1.00; Cat. II; Exp B; Enclosed; MWFRS (envelope) gable end zone; cantilever left and right exposed; end vertical left and right exposed; Lumber DOL=1.33 plate grip DOL=1.33
- 2) TCLL: ASCE 7-16; Pf=25.0 psf (Lum DOL = 1.15 Plate DOL = 1.15); Is=1.0; Rough Cat B; Partially Exp.; Ce=1.0; Cs=1.00; Ct=1.10
- 3) Unbalanced snow loads have been considered for this design.
- 4) Gable requires continuous bottom chord bearing.
- 5) This truss has been designed for a 10.0 psf bottom chord live load nonconcurrent with any other live loads.
- 6) * This truss has been designed for a live load of 20.0psf on the bottom chord in all areas where a rectangle 3-6-0 tall by 2-0-0 wide will fit between the bottom chord and any other members.
- 7) Provide mechanical connection (by others) of truss to bearing plate capable of withstanding 100 lb uplift at joint(s) A, C.
- 8) This truss is designed in accordance with the 2018 International Building Code section 2306.1 and referenced standard ANSI/TPI 1.



September 12, 2024

WARNING - Verify design parameters and READ NOTES ON THIS AND INCLUDED MITEK REFERENCE PAGE MII-7473 rev. 6/30/2020 BEFORE USE.

Design valid for use only with MiTek® connectors. This design is based only upon parameters shown, and is for an individual building component, not a truss system. Before use, the building designer must verify the applicability of design parameters and properly incorporate this design into the overall building design. Bracing indicated is to prevent buckling of individual truss web and/or chord members only. Additional temporary and permanent bracing is always required for stability and to prevent collapse with possible personal injury and property damage. For general guidance regarding the fabrication, storage, delivery, erection and bracing of trusses and truss systems, see

Safety Information available from Truss Plate Institute, 2670 Crain Highway, Suite 203 Waldorf, MD 20601

ANSI/TPI1 Quality Criteria, DSB-89 and BCSI Building Component



240 Stirling Crescent
 Bradford, ON. L3Z 4L5

Job N0653A	Truss VH1	Truss Type Valley	Qty 20	Ply 1	Buildings A-H Job Reference (optional)	U1530879
---------------	--------------	----------------------	-----------	----------	---	----------

Alliance Truss (CA), Abbotsford, BC - V2S 7P6, 8.820 s Aug 30 2024 MiTek Industries, Inc. Thu Sep 12 02:48:31 2024 Page 1

ID:hFyjDMxrTsEK_kgkR0vWVvzFlgc-vW9P9NMw6czYaFOZew5VMYtmwk0EjuD13OdixyeVqk

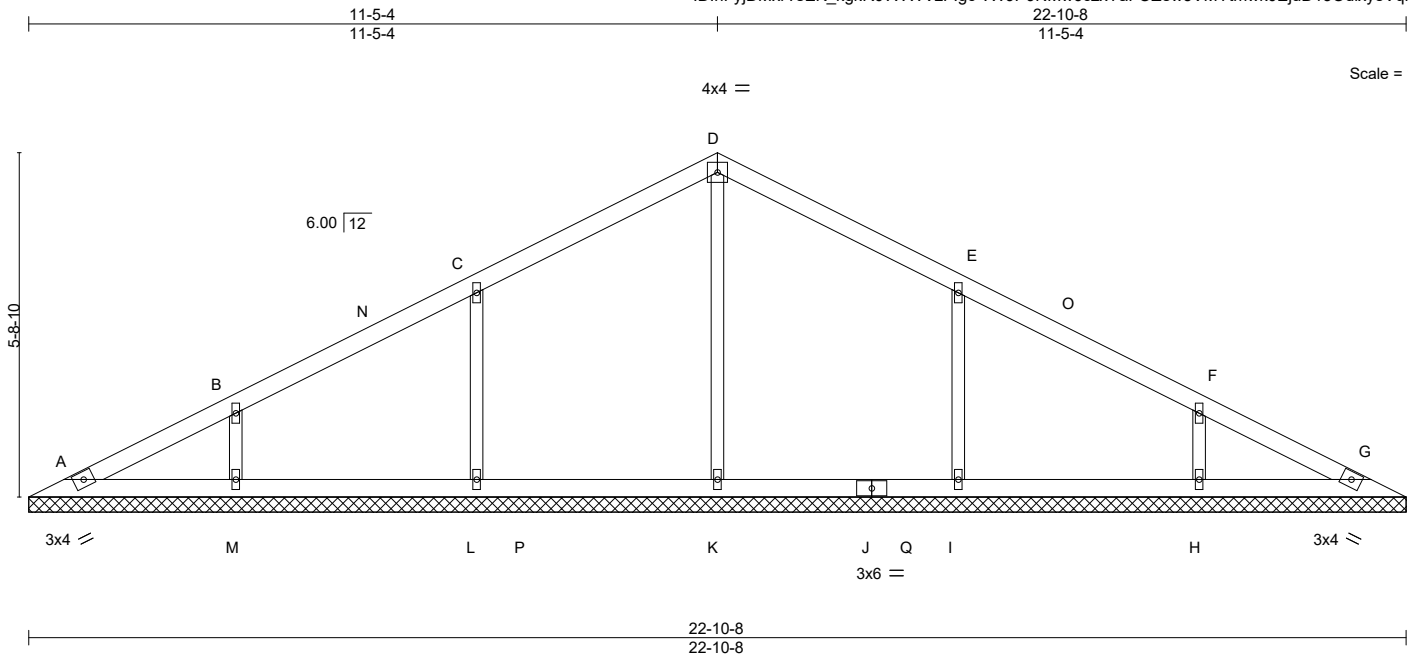

LOADING (psf)	SPACING-	CSI.	DEFL.	PLATES	GRIP
TCLL 25.0	2-0-0	TC 0.30	in (loc) l/defl L/d	MT20	197/144
(Roof Snow=25.0)	Plate Grip DOL 1.15	BC 0.14	Vert(LL) n/a - n/a 999		
TCDL 12.0	Lumber DOL 1.15	WB 0.17	Vert(CT) n/a - n/a 999		
BCLL 0.0 *	Rep Stress Incr YES	Matrix-S	Horz(CT) 0.00 G n/a n/a		
BCDL 10.0	Code IBC2018/TPI2014			Weight: 65 lb	FT = 20%

LUMBER-
 TOP CHORD 2x4 SPF No.2
 BOT CHORD 2x4 SPF No.2
 OTHERS 2x3 SPF No.2

BRACING-
 TOP CHORD Structural wood sheathing directly applied or 6-0-0 oc purlins.
 BOT CHORD Rigid ceiling directly applied or 10-0-0 oc bracing.

REACTIONS. All bearings 22-10-8.
 (lb) - Max Horz A=-71(LC 11)
 Max Uplift All uplift 100 lb or less at joint(s) A, L, M, I, H
 Max Grav All reactions 250 lb or less at joint(s) A, G except K=403(LC 3), L=551(LC 16), M=357(LC 2), I=551(LC 17), H=357(LC 2)

FORCES. (lb) - Max. Comp./Max. Ten. - All forces 250 (lb) or less except when shown.
 WEBS C-L=-470/129, B-M=-271/106, E-I=-470/129, F-H=-271/106

- NOTES-**
- 1) Wind: ASCE 7-16; Vult=115mph (3-second gust) Vasd=91mph; TCDL=4.2psf; BCDL=5.0psf; h=30ft; Ke=1.00; Cat. II; Exp B; Enclosed; MWFRS (envelope) gable end zone; cantilever left and right exposed ; end vertical left and right exposed; Lumber DOL=1.33 plate grip DOL=1.33
 - 2) TCLL: ASCE 7-16; Pf=25.0 psf (Lum DOL = 1.15 Plate DOL = 1.15); Is=1.0; Rough Cat B; Partially Exp.; Ce=1.0; Cs=1.00; Ct=1.10
 - 3) Unbalanced snow loads have been considered for this design.
 - 4) All plates are 1.5x4 MT20 unless otherwise indicated.
 - 5) Gable requires continuous bottom chord bearing.
 - 6) This truss has been designed for a 10.0 psf bottom chord live load nonconcurrent with any other live loads.
 - 7) * This truss has been designed for a live load of 20.0psf on the bottom chord in all areas where a rectangle 3-6-0 tall by 2-0-0 wide will fit between the bottom chord and any other members, with BCDL = 10.0psf.
 - 8) Provide mechanical connection (by others) of truss to bearing plate capable of withstanding 100 lb uplift at joint(s) A, L, M, I, H.
 - 9) This truss is designed in accordance with the 2018 International Building Code section 2306.1 and referenced standard ANSI/TPI 1.



September 12, 2024

WARNING - Verify design parameters and READ NOTES ON THIS AND INCLUDED MITEK REFERENCE PAGE MII-7473 rev. 6/30/2020 BEFORE USE.

Design valid for use only with MiTek® connectors. This design is based only upon parameters shown, and is for an individual building component, not a truss system. Before use, the building designer must verify the applicability of design parameters and properly incorporate this design into the overall building design. Bracing indicated is to prevent buckling of individual truss web and/or chord members only. Additional temporary and permanent bracing is always required for stability and to prevent collapse with possible personal injury and property damage. For general guidance regarding the fabrication, storage, delivery, erection and bracing of trusses and truss systems, see

Safety Information available from Truss Plate Institute, 2670 Crain Highway, Suite 203 Waldorf, MD 20601



240 Stirling Crescent
 Bradford, ON. L3Z 4L5

Job N0653A	Truss VH2	Truss Type Valley	Qty 20	Ply 1	Buildings A-H Job Reference (optional)	U1530880
---------------	--------------	----------------------	-----------	----------	---	----------

Alliance Truss (CA), Abbotsford, BC - V2S 7P6,

8.820 s Aug 30 2024 MiTek Industries, Inc. Thu Sep 12 02:48:32 2024 Page 1
ID:hFyjDMxrTsEK_kgkR0vWWVzFlgc-NijnMjNYtw5oAkqa7LRK2a5?zK2GzAiNGj8BENyeVqj

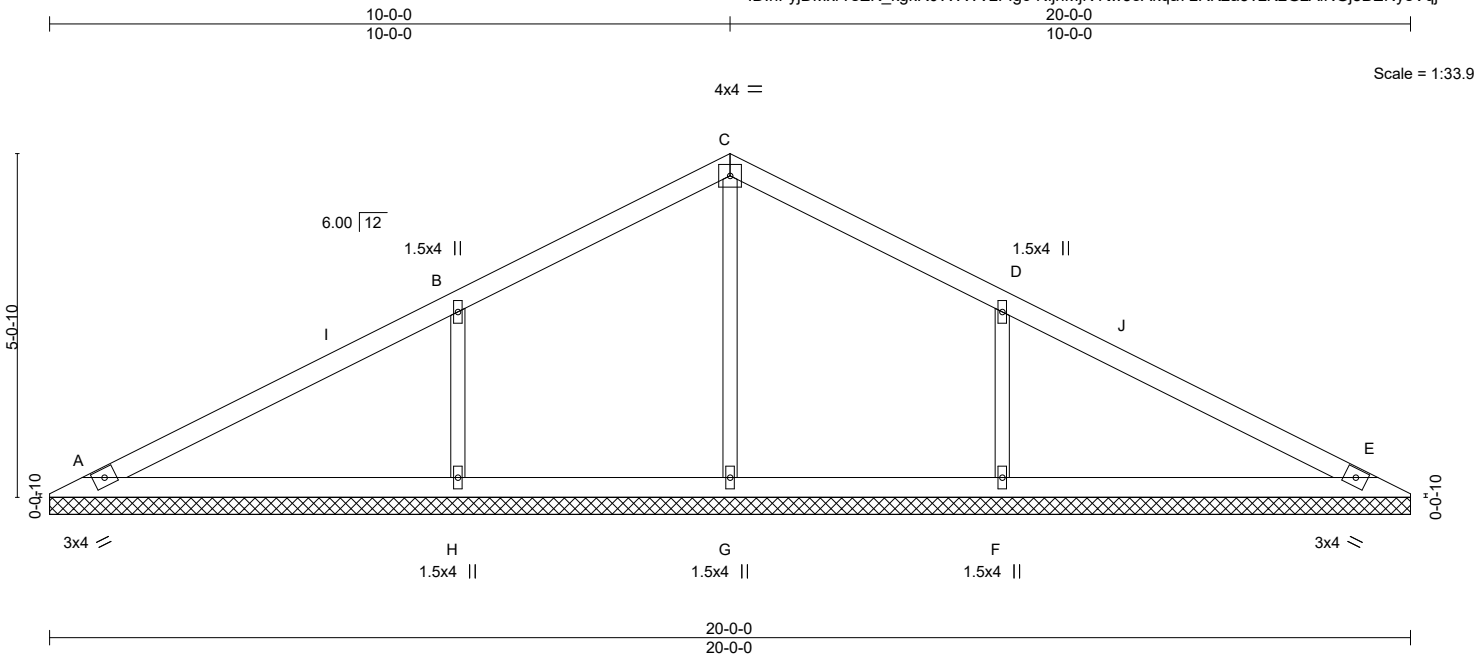

LOADING (psf)	SPACING-	CSI.	DEFL.	PLATES	GRIP
TCLL 25.0 (Roof Snow=25.0)	2-0-0 Plate Grip DOL 1.15 Lumber DOL 1.15	TC 0.46 BC 0.21 WB 0.14 Matrix-S	in (loc) l/defl L/d Vert(LL) n/a - n/a 999 Vert(CT) n/a - n/a 999 Horz(CT) 0.00 E n/a n/a	MT20	197/144
TCDL 12.0 BCLL 0.0 * BCDL 10.0	Rep Stress Incr YES Code IBC2018/TPI2014			Weight: 55 lb	FT = 20%

LUMBER-
TOP CHORD 2x4 SPF No.2
BOT CHORD 2x4 SPF No.2
OTHERS 2x3 SPF No.2

BRACING-
TOP CHORD Structural wood sheathing directly applied or 6-0-0 oc purlins.
BOT CHORD Rigid ceiling directly applied or 10-0-0 oc bracing.

REACTIONS. All bearings 20-0-0.
(lb) - Max Horz A=62(LC 14)
Max Uplift All uplift 100 lb or less at joint(s) A, E except H=-117(LC 10), F=-117(LC 11)
Max Grav All reactions 250 lb or less at joint(s) A, E, G except H=704(LC 16), F=704(LC 17)

FORCES. (lb) - Max. Comp./Max. Ten. - All forces 250 (lb) or less except when shown.
WEBS B-H=-572/165, D-F=-573/165

- NOTES-**
- 1) Wind: ASCE 7-16; Vult=115mph (3-second gust) Vasd=91mph; TCDL=4.2psf; BCDL=5.0psf; h=30ft; Ke=1.00; Cat. II; Exp B; Enclosed; MWFRS (envelope) gable end zone; cantilever left and right exposed; end vertical left and right exposed; Lumber DOL=1.33 plate grip DOL=1.33
 - 2) TCLL: ASCE 7-16; Pf=25.0 psf (Lum DOL = 1.15 Plate DOL = 1.15); Is=1.0; Rough Cat B; Partially Exp.; Ce=1.0; Cs=1.00; Ct=1.10
 - 3) Unbalanced snow loads have been considered for this design.
 - 4) Gable requires continuous bottom chord bearing.
 - 5) This truss has been designed for a 10.0 psf bottom chord live load nonconcurrent with any other live loads.
 - 6) * This truss has been designed for a live load of 20.0psf on the bottom chord in all areas where a rectangle 3-6-0 tall by 2-0-0 wide will fit between the bottom chord and any other members.
 - 7) Provide mechanical connection (by others) of truss to bearing plate capable of withstanding 100 lb uplift at joint(s) A, E except (jt=lb) H=117, F=117.
 - 8) This truss is designed in accordance with the 2018 International Building Code section 2306.1 and referenced standard ANSI/TPI 1.



September 12, 2024

WARNING - Verify design parameters and READ NOTES ON THIS AND INCLUDED MITEK REFERENCE PAGE MII-7473 rev. 6/30/2020 BEFORE USE.

Design valid for use only with MiTek® connectors. This design is based only upon parameters shown, and is for an individual building component, not a truss system. Before use, the building designer must verify the applicability of design parameters and properly incorporate this design into the overall building design. Bracing indicated is to prevent buckling of individual truss web and/or chord members only. Additional temporary and permanent bracing is always required for stability and to prevent collapse with possible personal injury and property damage. For general guidance regarding the fabrication, storage, delivery, erection and bracing of trusses and truss systems, see

Safety Information available from Truss Plate Institute, 2670 Crain Highway, Suite 203 Waldorf, MD 20601
ANSI/TPI1 Quality Criteria, DSB-89 and BCSI Building Component



240 Stirling Crescent
Bradford, ON. L3Z 4L5

Job N0653A	Truss VH3	Truss Type Valley	Qty 20	Ply 1	Buildings A-H Job Reference (optional)	U1530881
---------------	--------------	----------------------	-----------	----------	---	----------

Alliance Truss (CA), Abbotsford, BC - V2S 7P6,

8.820 s Aug 30 2024 MiTek Industries, Inc. Thu Sep 12 02:48:32 2024 Page 1

ID:hFyjDMxrTsEK_kgkR0vWwVzFlgc-NijnMjNYtw5oAkqa7LRK2a51sK4bzBGNGj8BENyeVqj

17-6-8

8-9-4

Scale = 1:29.5

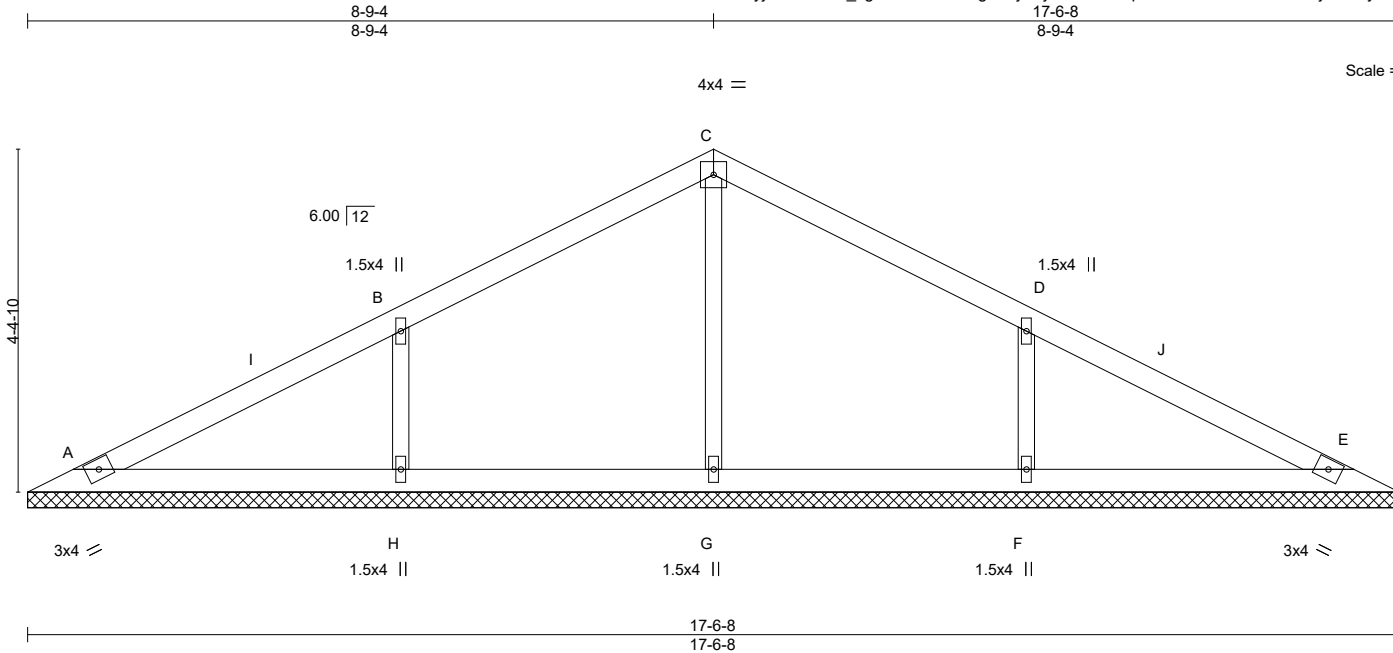

LOADING (psf)	SPACING-	CSI.	DEFL.	PLATES	GRIP
TCLL 25.0	2-0-0	TC 0.34	in (loc) l/defl L/d	MT20	197/144
(Roof Snow=25.0)	Plate Grip DOL 1.15	BC 0.12	Vert(LL) n/a - n/a 999		
TCDL 12.0	Lumber DOL 1.15	WB 0.10	Vert(CT) n/a - n/a 999		
BCLL 0.0 *	Rep Stress Incr YES	Matrix-S	Horz(CT) 0.00 E n/a n/a		
BCDL 10.0	Code IBC2018/TPI2014			Weight: 47 lb	FT = 20%

LUMBER-

TOP CHORD 2x4 SPF No.2
 BOT CHORD 2x4 SPF No.2
 OTHERS 2x3 SPF No.2

BRACING-

TOP CHORD Structural wood sheathing directly applied or 6-0-0 oc purlins.
 BOT CHORD Rigid ceiling directly applied or 10-0-0 oc bracing.

REACTIONS.

All bearings 17-6-8.
 (lb) - Max Horz A=53(LC 10)
 Max Uplift All uplift 100 lb or less at joint(s) A, E, H, F
 Max Grav All reactions 250 lb or less at joint(s) A, E except G=298(LC 16), H=604(LC 16), F=604(LC 17)

FORCES. (lb) - Max. Comp./Max. Ten. - All forces 250 (lb) or less except when shown.
 WEBS B-H=-502/139, D-F=-502/139

NOTES-

- 1) Wind: ASCE 7-16; Vult=115mph (3-second gust) Vasd=91mph; TCDL=4.2psf; BCDL=5.0psf; h=30ft; Ke=1.00; Cat. II; Exp B; Enclosed; MWFRS (envelope) gable end zone; cantilever left and right exposed; end vertical left and right exposed; Lumber DOL=1.33 plate grip DOL=1.33
- 2) TCLL: ASCE 7-16; Pf=25.0 psf (Lum DOL = 1.15 Plate DOL = 1.15); Is=1.0; Rough Cat B; Partially Exp.; Ce=1.0; Cs=1.00; Ct=1.10
- 3) Unbalanced snow loads have been considered for this design.
- 4) Gable requires continuous bottom chord bearing.
- 5) This truss has been designed for a 10.0 psf bottom chord live load nonconcurrent with any other live loads.
- 6) * This truss has been designed for a live load of 20.0psf on the bottom chord in all areas where a rectangle 3-6-0 tall by 2-0-0 wide will fit between the bottom chord and any other members.
- 7) Provide mechanical connection (by others) of truss to bearing plate capable of withstanding 100 lb uplift at joint(s) A, E, H, F.
- 8) This truss is designed in accordance with the 2018 International Building Code section 2306.1 and referenced standard ANSI/TPI 1.



September 12, 2024

WARNING - Verify design parameters and READ NOTES ON THIS AND INCLUDED MITEK REFERENCE PAGE MII-7473 rev. 6/30/2020 BEFORE USE.

Design valid for use only with MiTek® connectors. This design is based only upon parameters shown, and is for an individual building component, not a truss system. Before use, the building designer must verify the applicability of design parameters and properly incorporate this design into the overall building design. Bracing indicated is to prevent buckling of individual truss web and/or chord members only. Additional temporary and permanent bracing is always required for stability and to prevent collapse with possible personal injury and property damage. For general guidance regarding the fabrication, storage, delivery, erection and bracing of trusses and truss systems, see

ANSI/TPI1 Quality Criteria, DSB-89 and BCSI Building Component

Safety Information available from Truss Plate Institute, 2670 Crain Highway, Suite 203 Waldorf, MD 20601



240 Stirling Crescent
 Bradford, ON. L3Z 4L5

Job N0653A	Truss VH4	Truss Type Valley	Qty 20	Ply 1	Buildings A-H Job Reference (optional)	U1530882
---------------	--------------	----------------------	-----------	----------	---	----------

Alliance Truss (CA), Abbotsford, BC - V2S 7P6, 8.820 s Aug 30 2024 MiTek Industries, Inc. Thu Sep 12 02:48:33 2024 Page 1

ID:hFyjDMxrTsEK_kgkR0vWWVzFgC-rvHAa3OAeDDfntPmg3yZbndDekQBieoWUNtkmqyeVqi
14-10-8
7-5-4

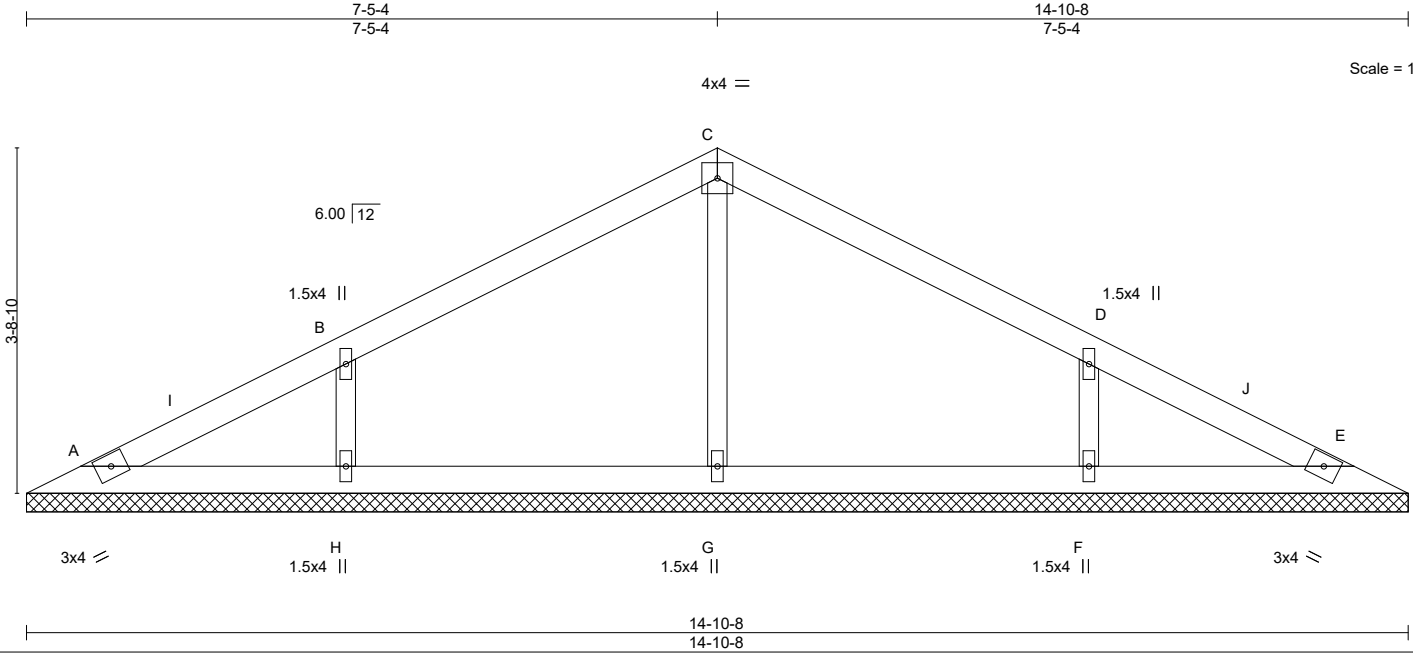

Scale = 1:24.8

LOADING (psf)	SPACING-	2-0-0	CSI.	DEFL.	in (loc)	l/defl	L/d	PLATES	GRIP	
TCLL 25.0	Plate Grip DOL	1.15	TC 0.28	Vert(LL)	n/a	-	n/a	999	MT20	197/144
(Roof Snow=25.0)	Lumber DOL	1.15	BC 0.10	Vert(CT)	n/a	-	n/a	999		
TCDL 12.0	Rep Stress Incr	YES	WB 0.08	Horz(CT)	0.00	E	n/a	n/a		
BCLL 0.0 *	Code IBC2018/TPI2014		Matrix-S							
BCDL 10.0									Weight: 39 lb	FT = 20%

LUMBER-	BRACING-
TOP CHORD 2x4 SPF No.2	TOP CHORD Structural wood sheathing directly applied or 6-0-0 oc purlins.
BOT CHORD 2x4 SPF No.2	BOT CHORD Rigid ceiling directly applied or 10-0-0 oc bracing.
OTHERS 2x3 SPF No.2	

REACTIONS. All bearings 14-10-8.
 (lb) - Max Horz A=-45(LC 11)
 Max Uplift All uplift 100 lb or less at joint(s) A, H, F
 Max Grav All reactions 250 lb or less at joint(s) A, E except G=326(LC 16), H=526(LC 16), F=526(LC 17)

FORCES. (lb) - Max. Comp./Max. Ten. - All forces 250 (lb) or less except when shown.
 WEBS B-H=-449/119, D-F=-449/119

- NOTES-**
- 1) Wind: ASCE 7-16; Vult=115mph (3-second gust) Vasd=91mph; TCDL=4.2psf; BCDL=5.0psf; h=30ft; Ke=1.00; Cat. II; Exp B; Enclosed; MWFRS (envelope) gable end zone; cantilever left and right exposed; end vertical left and right exposed; Lumber DOL=1.33 plate grip DOL=1.33
 - 2) TCLL: ASCE 7-16; Pf=25.0 psf (Lum DOL = 1.15 Plate DOL = 1.15); Is=1.0; Rough Cat B; Partially Exp.; Ce=1.0; Cs=1.00; Ct=1.10
 - 3) Unbalanced snow loads have been considered for this design.
 - 4) Gable requires continuous bottom chord bearing.
 - 5) This truss has been designed for a 10.0 psf bottom chord live load nonconcurrent with any other live loads.
 - 6) * This truss has been designed for a live load of 20.0psf on the bottom chord in all areas where a rectangle 3-6-0 tall by 2-0-0 wide will fit between the bottom chord and any other members.
 - 7) Provide mechanical connection (by others) of truss to bearing plate capable of withstanding 100 lb uplift at joint(s) A, H, F.
 - 8) This truss is designed in accordance with the 2018 International Building Code section 2306.1 and referenced standard ANSI/TPI 1.



September 12, 2024

WARNING - Verify design parameters and READ NOTES ON THIS AND INCLUDED MITEK REFERENCE PAGE MII-7473 rev. 6/30/2020 BEFORE USE.
 Design valid for use only with MiTek® connectors. This design is based only upon parameters shown, and is for an individual building component, not a truss system. Before use, the building designer must verify the applicability of design parameters and properly incorporate this design into the overall building design. Bracing indicated is to prevent buckling of individual truss web and/or chord members only. Additional temporary and permanent bracing is always required for stability and to prevent collapse with possible personal injury and property damage. For general guidance regarding the fabrication, storage, delivery, erection and bracing of trusses and truss systems, see **ANSI/TPI1 Quality Criteria, DSB-89 and BCSI Building Component Safety Information** available from Truss Plate Institute, 2670 Crain Highway, Suite 203 Waldorf, MD 20601



240 Stirling Crescent
Bradford, ON. L3Z 4L5

Job N0653A	Truss VH5	Truss Type GABLE	Qty 20	Ply 1	Buildings A-H Job Reference (optional)	U1530883
---------------	--------------	---------------------	-----------	----------	---	----------

Alliance Truss (CA), Abbotsford, BC - V2S 7P6,

8.820 s Aug 30 2024 MiTek Industries, Inc. Thu Sep 12 02:48:33 2024 Page 1

ID:hFyjDMxrTsEK_kgkR0vWWWzF1gc-rvHAa3OAeDDfntPmg3yZbndEOkQRiexWUNtkmqyeVqi

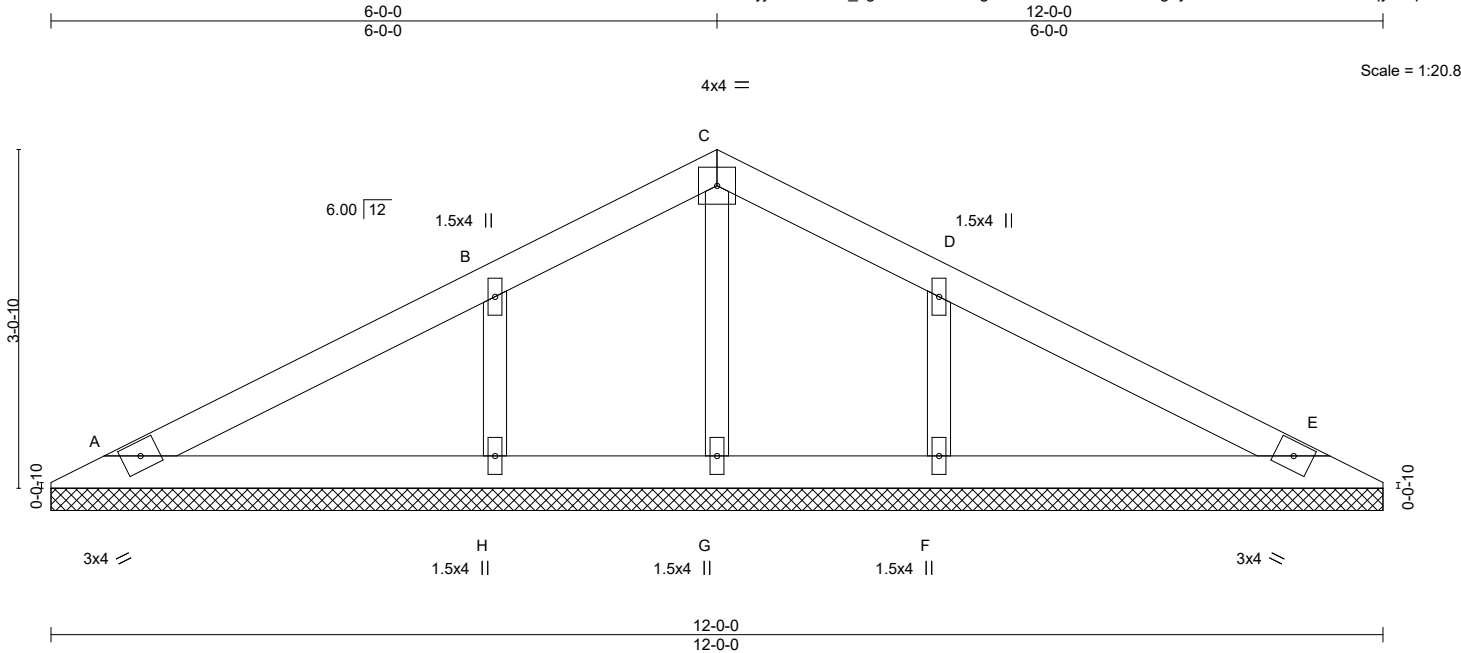

LOADING (psf)	SPACING-	CSI.	DEFL.	PLATES	GRIP
TCLL 25.0 (Roof Snow=25.0)	2-0-0 Plate Grip DOL 1.15 Lumber DOL 1.15	TC 0.23 BC 0.08 WB 0.07 Matrix-S	in (loc) l/defl L/d Vert(LL) n/a - n/a 999 Vert(CT) n/a - n/a 999 Horz(CT) 0.00 E n/a n/a	MT20	197/144
TCDL 12.0 BCLL 0.0 * BCDL 10.0	Rep Stress Incr YES Code IBC2018/TPI2014			Weight: 32 lb	FT = 20%

LUMBER-
 TOP CHORD 2x4 SPF No.2
 BOT CHORD 2x4 SPF No.2
 OTHERS 2x3 SPF No.2

BRACING-
 TOP CHORD Structural wood sheathing directly applied or 6-0-0 oc purlins.
 BOT CHORD Rigid ceiling directly applied or 10-0-0 oc bracing.

REACTIONS. All bearings 12-0-0.
 (lb) - Max Horz A=36(LC 14)
 Max Uplift All uplift 100 lb or less at joint(s) A, E, H, F
 Max Grav All reactions 250 lb or less at joint(s) A, E, G except H=483(LC 16), F=483(LC 17)

FORCES. (lb) - Max. Comp./Max. Ten. - All forces 250 (lb) or less except when shown.
 WEBS B-H=-391/99, D-F=-391/99

- NOTES-**
- 1) Wind: ASCE 7-16; Vult=115mph (3-second gust) Vasd=91mph; TCDL=4.2psf; BCDL=5.0psf; h=30ft; Ke=1.00; Cat. II; Exp B; Enclosed; MWFRS (envelope) gable end zone; cantilever left and right exposed; end vertical left and right exposed; Lumber DOL=1.33 plate grip DOL=1.33
 - 2) TCLL: ASCE 7-16; Pf=25.0 psf (Lum DOL = 1.15 Plate DOL = 1.15); Is=1.0; Rough Cat B; Partially Exp.; Ce=1.0; Cs=1.00; Ct=1.10
 - 3) Unbalanced snow loads have been considered for this design.
 - 4) Gable requires continuous bottom chord bearing.
 - 5) This truss has been designed for a 10.0 psf bottom chord live load nonconcurrent with any other live loads.
 - 6) * This truss has been designed for a live load of 20.0psf on the bottom chord in all areas where a rectangle 3-6-0 tall by 2-0-0 wide will fit between the bottom chord and any other members.
 - 7) Provide mechanical connection (by others) of truss to bearing plate capable of withstanding 100 lb uplift at joint(s) A, E, H, F.
 - 8) This truss is designed in accordance with the 2018 International Building Code section 2306.1 and referenced standard ANSI/TPI 1.



September 12, 2024

WARNING - Verify design parameters and READ NOTES ON THIS AND INCLUDED MITEK REFERENCE PAGE MII-7473 rev. 6/30/2020 BEFORE USE.

Design valid for use only with MiTek® connectors. This design is based only upon parameters shown, and is for an individual building component, not a truss system. Before use, the building designer must verify the applicability of design parameters and properly incorporate this design into the overall building design. Bracing indicated is to prevent buckling of individual truss web and/or chord members only. Additional temporary and permanent bracing is always required for stability and to prevent collapse with possible personal injury and property damage. For general guidance regarding the fabrication, storage, delivery, erection and bracing of trusses and truss systems, see

Safety Information available from Truss Plate Institute, 2670 Crain Highway, Suite 203 Waldorf, MD 20601



240 Stirling Crescent
 Bradford, ON. L3Z 4L5

Job	Truss	Truss Type	Qty	Ply	Buildings A-H	U1530884
N0653A	VH6	Valley	20	1		

Alliance Truss (CA), Abbotsford, BC - V2S 7P6,

8.820 s Aug 30 2024 MiTek Industries, Inc. Thu Sep 12 02:48:34 2024 Page 1

ID:hFyjDMxrTsEK_kgkR0vWWVzFlgc-K5qYnOPpPXMWP1_zEmTo7?AMOBjdR6Lgj1dHIGyeVqh

Job Reference (optional)

9-6-8

4-9-4

Scale = 1:17.2

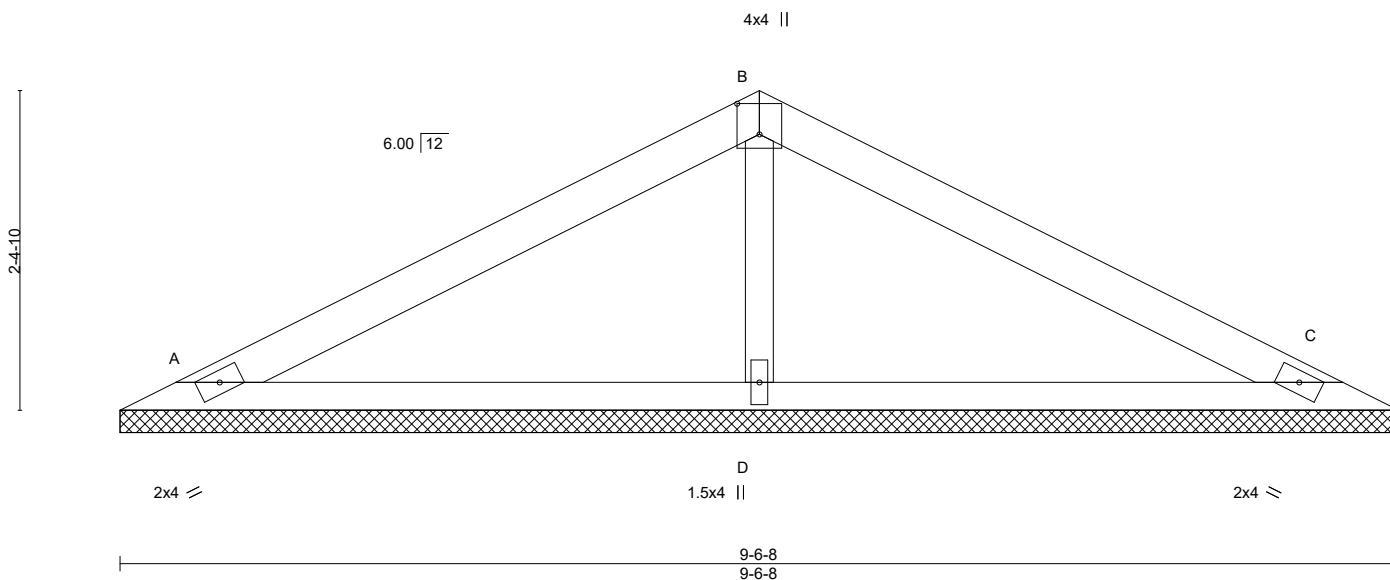

Plate Offsets (X,Y)-- [B:0-2-12,0-2-0]

LOADING (psf)		SPACING-		CSI.		DEFL.				PLATES		GRIP	
TCLL	25.0	Plate Grip DOL	1.15	TC	0.41	Vert(LL)	n/a	-	n/a	999	MT20	197/144	
(Roof Snow=25.0)		Lumber DOL	1.15	BC	0.28	Vert(CT)	n/a	-	n/a	999			
TCDL	12.0	Rep Stress Incr	YES	WB	0.06	Horz(CT)	0.00	C	n/a	n/a			
BCLL	0.0 *	Code IBC2018/TPI2014		Matrix-S							Weight: 20 lb	FT = 20%	
BCDL	10.0												

LUMBER-

TOP CHORD 2x4 SPF No.2
 BOT CHORD 2x3 SPF No.2
 OTHERS 2x3 SPF No.2

BRACING-

TOP CHORD Structural wood sheathing directly applied or 6-0-0 oc purlins.
 BOT CHORD Rigid ceiling directly applied or 10-0-0 oc bracing.

REACTIONS.

(size) A=9-6-8, C=9-6-8, D=9-6-8
 Max Horz A=-28(LC 15)
 Max Uplift A=-27(LC 10), C=-33(LC 11), D=-12(LC 10)
 Max Grav A=262(LC 16), C=262(LC 17), D=424(LC 16)

FORCES. (lb) - Max. Comp./Max. Ten. - All forces 250 (lb) or less except when shown.

WEBS B-D=-309/57

NOTES-

- Wind: ASCE 7-16; Vult=115mph (3-second gust) Vasd=91mph; TCDL=4.2psf; BCDL=5.0psf; h=30ft; Ke=1.00; Cat. II; Exp B; Enclosed; MWFRS (envelope) gable end zone; cantilever left and right exposed; end vertical left and right exposed; Lumber DOL=1.33 plate grip DOL=1.33
- TCLL: ASCE 7-16; Pf=25.0 psf (Lum DOL = 1.15 Plate DOL = 1.15); Is=1.0; Rough Cat B; Partially Exp.; Ce=1.0; Cs=1.00; Ct=1.10
- Unbalanced snow loads have been considered for this design.
- Gable requires continuous bottom chord bearing.
- This truss has been designed for a 10.0 psf bottom chord live load nonconcurrent with any other live loads.
- * This truss has been designed for a live load of 20.0psf on the bottom chord in all areas where a rectangle 3-6-0 tall by 2-0-0 wide will fit between the bottom chord and any other members.
- Provide mechanical connection (by others) of truss to bearing plate capable of withstanding 100 lb uplift at joint(s) A, C, D.
- This truss is designed in accordance with the 2018 International Building Code section 2306.1 and referenced standard ANSI/TPI 1.



September 12, 2024

WARNING - Verify design parameters and READ NOTES ON THIS AND INCLUDED MITEK REFERENCE PAGE MII-7473 rev. 6/30/2020 BEFORE USE.

Design valid for use only with MiTek® connectors. This design is based only upon parameters shown, and is for an individual building component, not a truss system. Before use, the building designer must verify the applicability of design parameters and properly incorporate this design into the overall building design. Bracing indicated is to prevent buckling of individual truss web and/or chord members only. Additional temporary and permanent bracing is always required for stability and to prevent collapse with possible personal injury and property damage. For general guidance regarding the fabrication, storage, delivery, erection and bracing of trusses and truss systems, see

Safety Information available from Truss Plate Institute, 2670 Crain Highway, Suite 203 Waldorf, MD 20601

ANSI/TPI1 Quality Criteria, DSB-89 and BCSI Building Component



240 Stirling Crescent
 Bradford, ON. L3Z 4L5

Job	Truss	Truss Type	Qty	Ply	Buildings A-H	U1530885
N0653A	VH7	Valley	20	1		

Alliance Truss (CA), Abbotsford, BC - V2S 7P6, 8.820 s Aug 30 2024 MiTek Industries, Inc. Thu Sep 12 02:48:34 2024 Page 1

ID:hFyjDMxrTsEK_kgkR0vWWVzFfgc-K5qYnOPpPXMWP1_zEmTo7?APH8IIR6mgj1dHIGyeVqh

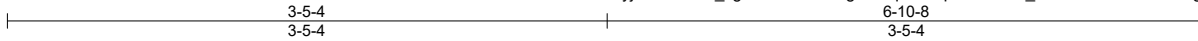

Scale = 1:13.2

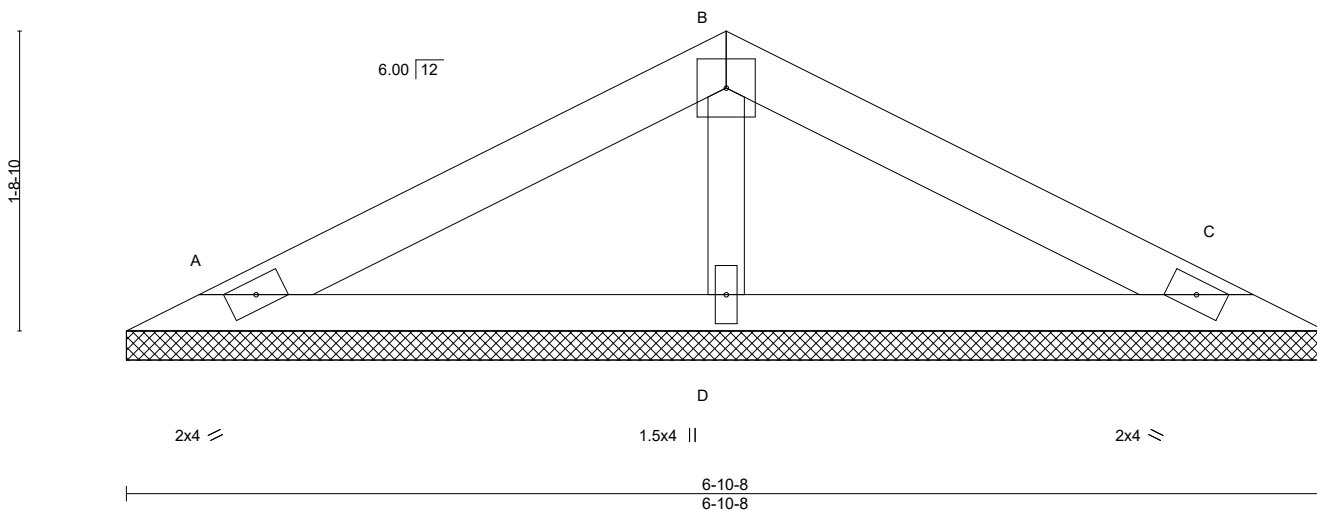

LOADING (psf)	SPACING-	CSI.	DEFL.	PLATES	GRIP
TCLL 25.0	2-0-0	TC 0.22	in (loc) l/defl L/d	MT20	197/144
(Roof Snow=25.0)	Plate Grip DOL 1.15	BC 0.14	Vert(LL) n/a - n/a 999		
TCDL 12.0	Lumber DOL 1.15	WB 0.04	Vert(CT) n/a - n/a 999		
BCLL 0.0 *	Rep Stress Incr YES	Matrix-P	Horz(CT) 0.00 C n/a n/a		
BCDL 10.0	Code IBC2018/TPI2014			Weight: 14 lb	FT = 20%

LUMBER-

TOP CHORD 2x4 SPF No.2
 BOT CHORD 2x3 SPF No.2
 OTHERS 2x3 SPF No.2

BRACING-

TOP CHORD Structural wood sheathing directly applied or 6-0-0 oc purlins.
 BOT CHORD Rigid ceiling directly applied or 10-0-0 oc bracing.

REACTIONS.

(size) A=6-10-8, C=6-10-8, D=6-10-8
 Max Horz A=-19(LC 15)
 Max Uplift A=-23(LC 10), C=-27(LC 11)
 Max Grav A=183(LC 16), C=183(LC 17), D=264(LC 1)

FORCES. (lb) - Max. Comp./Max. Ten. - All forces 250 (lb) or less except when shown.

NOTES-

- 1) Wind: ASCE 7-16; Vult=115mph (3-second gust) Vasd=91mph; TCDL=4.2psf; BCDL=5.0psf; h=30ft; Ke=1.00; Cat. II; Exp B; Enclosed; MWFRS (envelope) gable end zone; cantilever left and right exposed; end vertical left and right exposed; Lumber DOL=1.33 plate grip DOL=1.33
- 2) TCLL: ASCE 7-16; Pf=25.0 psf (Lum DOL = 1.15 Plate DOL = 1.15); Is=1.0; Rough Cat B; Partially Exp.; Ce=1.0; Cs=1.00; Ct=1.10
- 3) Unbalanced snow loads have been considered for this design.
- 4) Gable requires continuous bottom chord bearing.
- 5) This truss has been designed for a 10.0 psf bottom chord live load nonconcurrent with any other live loads.
- 6) * This truss has been designed for a live load of 20.0psf on the bottom chord in all areas where a rectangle 3-6-0 tall by 2-0-0 wide will fit between the bottom chord and any other members.
- 7) Provide mechanical connection (by others) of truss to bearing plate capable of withstanding 100 lb uplift at joint(s) A, C.
- 8) This truss is designed in accordance with the 2018 International Building Code section 2306.1 and referenced standard ANSI/TPI 1.



September 12, 2024

WARNING - Verify design parameters and READ NOTES ON THIS AND INCLUDED MITEK REFERENCE PAGE MII-7473 rev. 6/30/2020 BEFORE USE.

Design valid for use only with MiTek® connectors. This design is based only upon parameters shown, and is for an individual building component, not a truss system. Before use, the building designer must verify the applicability of design parameters and properly incorporate this design into the overall building design. Bracing indicated is to prevent buckling of individual truss web and/or chord members only. Additional temporary and permanent bracing is always required for stability and to prevent collapse with possible personal injury and property damage. For general guidance regarding the fabrication, storage, delivery, erection and bracing of trusses and truss systems, see

Safety Information available from Truss Plate Institute, 2670 Crain Highway, Suite 203 Waldorf, MD 20601



240 Stirling Crescent
 Bradford, ON. L3Z 4L5

Job	Truss	Truss Type	Qty	Ply	Buildings A-H	U1530886
N0653A	VH8	Valley	20	1		

Alliance Truss (CA), Abbotsford, BC - V2S 7P6, 8.820 s Aug 30 2024 MiTek Industries, Inc. Thu Sep 12 02:48:34 2024 Page 1
 ID:hFyjDMxrTsEK_kgkR0vWWVzFlgc-K5qYnOPpPXMWP1_zEmTo7?ASu8khR6Jg1dHIGyeVqh

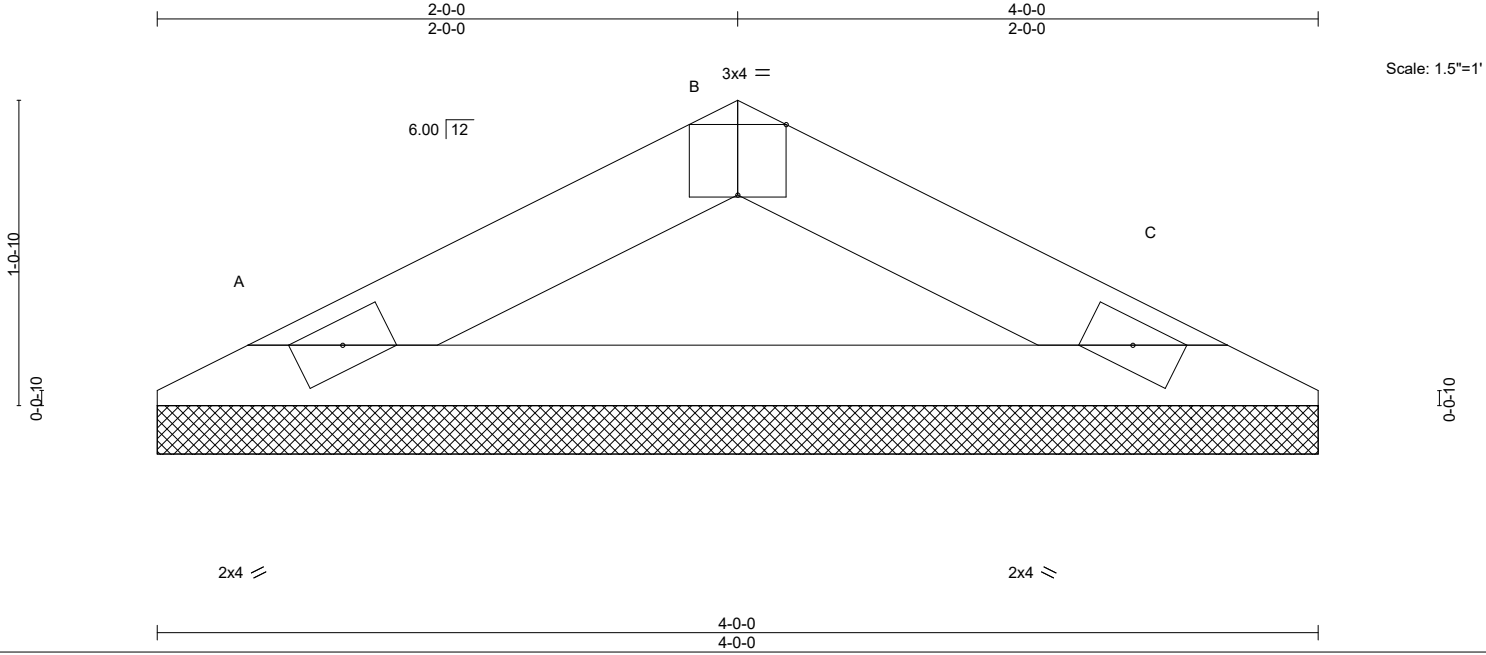

LOADING (psf)		SPACING-		CSI.		DEFL.				PLATES		GRIP	
TCLL	25.0	Plate Grip DOL	1.15	TC	0.05	Vert(LL)	n/a	-	n/a	999	MT20	197/144	
(Roof Snow=25.0)		Lumber DOL	1.15	BC	0.21	Vert(CT)	n/a	-	n/a	999			
TCDL	12.0	Rep Stress Incr	YES	WB	0.00	Horz(CT)	0.00	C	n/a	n/a			
BCLL	0.0 *	Code IBC2018/TPI2014		Matrix-P							Weight: 8 lb	FT = 20%	
BCDL	10.0												

LUMBER-		BRACING-	
TOP CHORD	2x4 SPF No.2	TOP CHORD	Structural wood sheathing directly applied or 4-2-8 oc purlins.
BOT CHORD	2x3 SPF No.2	BOT CHORD	Rigid ceiling directly applied or 10-0-0 oc bracing.

REACTIONS. (size) A=4-0-0, C=4-0-0
 Max Horz A=-10(LC 15)
 Max Uplift A=-12(LC 10), C=-12(LC 11)
 Max Grav A=159(LC 16), C=159(LC 17)

FORCES. (lb) - Max. Comp./Max. Ten. - All forces 250 (lb) or less except when shown.

- NOTES-**
- 1) Wind: ASCE 7-16; Vult=115mph (3-second gust) Vasd=91mph; TCDL=4.2psf; BCDL=5.0psf; h=30ft; Ke=1.00; Cat. II; Exp B; Enclosed; MWFRS (envelope) gable end zone; cantilever left and right exposed ; end vertical left and right exposed; Lumber DOL=1.33 plate grip DOL=1.33
 - 2) TCLL: ASCE 7-16; Pf=25.0 psf (Lum DOL = 1.15 Plate DOL = 1.15); Is=1.0; Rough Cat B; Partially Exp.; Ce=1.0; Cs=1.00; Ct=1.10
 - 3) Unbalanced snow loads have been considered for this design.
 - 4) Gable requires continuous bottom chord bearing.
 - 5) This truss has been designed for a 10.0 psf bottom chord live load nonconcurrent with any other live loads.
 - 6) * This truss has been designed for a live load of 20.0psf on the bottom chord in all areas where a rectangle 3-6-0 tall by 2-0-0 wide will fit between the bottom chord and any other members.
 - 7) Provide mechanical connection (by others) of truss to bearing plate capable of withstanding 100 lb uplift at joint(s) A, C.
 - 8) This truss is designed in accordance with the 2018 International Building Code section 2306.1 and referenced standard ANSI/TPI 1.



September 12, 2024

Job	Truss	Truss Type	Qty	Ply	Buildings A-H	U1530806
N0653A	VR1	Valley	1	1		

Alliance Truss (CA), Abbotsford, BC - V2S 7P6,

8.630 s Jul 12 2024 MiTek Industries, Inc. Thu Sep 12 02:47:48 2024 Page 1

ID:hFyjDMxrTsEK_kgkR0vWWVzFgC-RfC?PsB70Hq3NSgPqnL8w3ulTXbGKWrCDoi7J4zJC?f

Job Reference (optional)

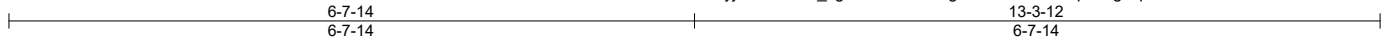

Scale = 1:22.4

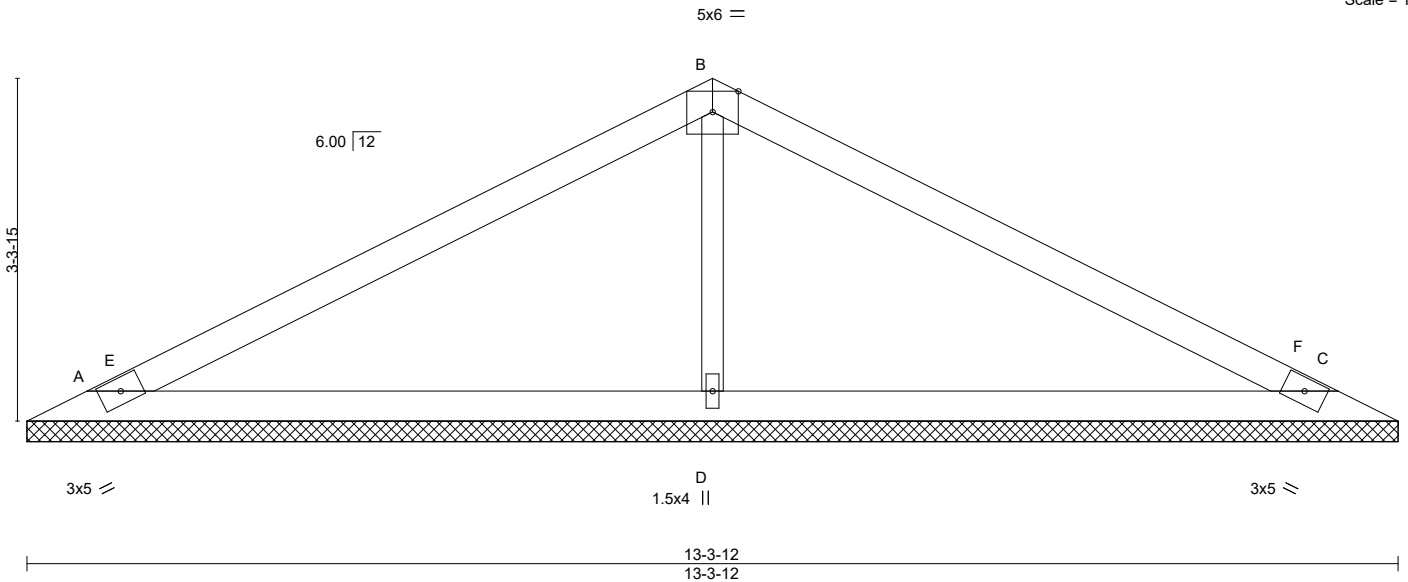

LOADING (psf)	SPACING-	CSI.	DEFL.	PLATES	GRIP
TCLL 25.0 (Roof Snow=25.0)	2-0-0 Plate Grip DOL 1.15 Lumber DOL 1.15	TC 0.83 BC 0.32 WB 0.11 Matrix-S	in (loc) l/defl L/d Vert(LL) n/a - n/a 999 Vert(CT) n/a - n/a 999 Horz(CT) 0.00 C n/a n/a	MT20	197/144
TCDL 12.0 BCLL 0.0 * BCDL 10.0	Rep Stress Incr YES Code IBC2018/TPI2014			Weight: 33 lb	FT = 20%

LUMBER-
TOP CHORD 2x4 SPF No.2
BOT CHORD 2x4 SPF No.2
OTHERS 2x3 SPF No.2

BRACING-
TOP CHORD Structural wood sheathing directly applied or 4-8-11 oc purlins.
BOT CHORD Rigid ceiling directly applied or 10-0-0 oc bracing.

REACTIONS. (size) A=13-3-12, C=13-3-12, D=13-3-12
Max Horz A=-39(LC 11)
Max Uplift A=-38(LC 10), C=-45(LC 11), D=-18(LC 10)
Max Grav A=365(LC 16), C=365(LC 17), D=610(LC 17)

FORCES. (lb) - Max. Comp./Max. Ten. - All forces 250 (lb) or less except when shown.
WEBS B-D=-425/79

- NOTES-**
- 1) Wind: ASCE 7-16; Vult=115mph (3-second gust) Vasd=91mph; TCDL=4.2psf; BCDL=5.0psf; h=30ft; Ke=1.00; Cat. II; Exp B; Enclosed; MWFRS (envelope) gable end zone; cantilever left and right exposed; end vertical left and right exposed; Lumber DOL=1.33 plate grip DOL=1.33
 - 2) TCLL: ASCE 7-16; Pf=25.0 psf (Lum DOL=1.15 Plate DOL=1.15); Is=1.0; Rough Cat B; Partially Exp.; Ce=1.0; Cs=1.0; Ct=1.10
 - 3) Unbalanced snow loads have been considered for this design.
 - 4) Gable requires continuous bottom chord bearing.
 - 5) This truss has been designed for a 10.0 psf bottom chord live load nonconcurrent with any other live loads.
 - 6) * This truss has been designed for a live load of 20.0psf on the bottom chord in all areas where a rectangle 3-6-0 tall by 2-0-0 wide will fit between the bottom chord and any other members.
 - 7) Provide mechanical connection (by others) of truss to bearing plate capable of withstanding 100 lb uplift at joint(s) A, C, D.
 - 8) This truss is designed in accordance with the 2018 International Building Code section 2306.1 and referenced standard ANSI/TPI 1.



September 12, 2024

WARNING - Verify design parameters and READ NOTES ON THIS AND INCLUDED MITEK REFERENCE PAGE MII-7473 rev. 6/30/2020 BEFORE USE.

Design valid for use only with MiTek® connectors. This design is based only upon parameters shown, and is for an individual building component, not a truss system. Before use, the building designer must verify the applicability of design parameters and properly incorporate this design into the overall building design. Bracing indicated is to prevent buckling of individual truss web and/or chord members only. Additional temporary and permanent bracing is always required for stability and to prevent collapse with possible personal injury and property damage. For general guidance regarding the fabrication, storage, delivery, erection and bracing of trusses and truss systems, see

Safety Information available from Truss Plate Institute, 2670 Crain Highway, Suite 203 Waldorf, MD 20601

ANSI/TPI1 Quality Criteria, DSB-89 and BCSI Building Component



240 Stirling Crescent
Bradford, ON. L3Z 4L5

Job	Truss	Truss Type	Qty	Ply	Buildings A-H	U1530807
N0653A	VR2	Valley	1	1		

Alliance Truss (CA), Abbotsford, BC - V2S 7P6, 8.630 s Jul 12 2024 MiTek Industries, Inc. Thu Sep 12 02:47:48 2024 Page 1

ID:hFyjDMxrTsEK_kgkR0vWWVzFgc-RfC?PsB70Hq3NSgPqnL8w3ulTXbGKWrCDoi7J4zJC?f

Job Reference (optional)

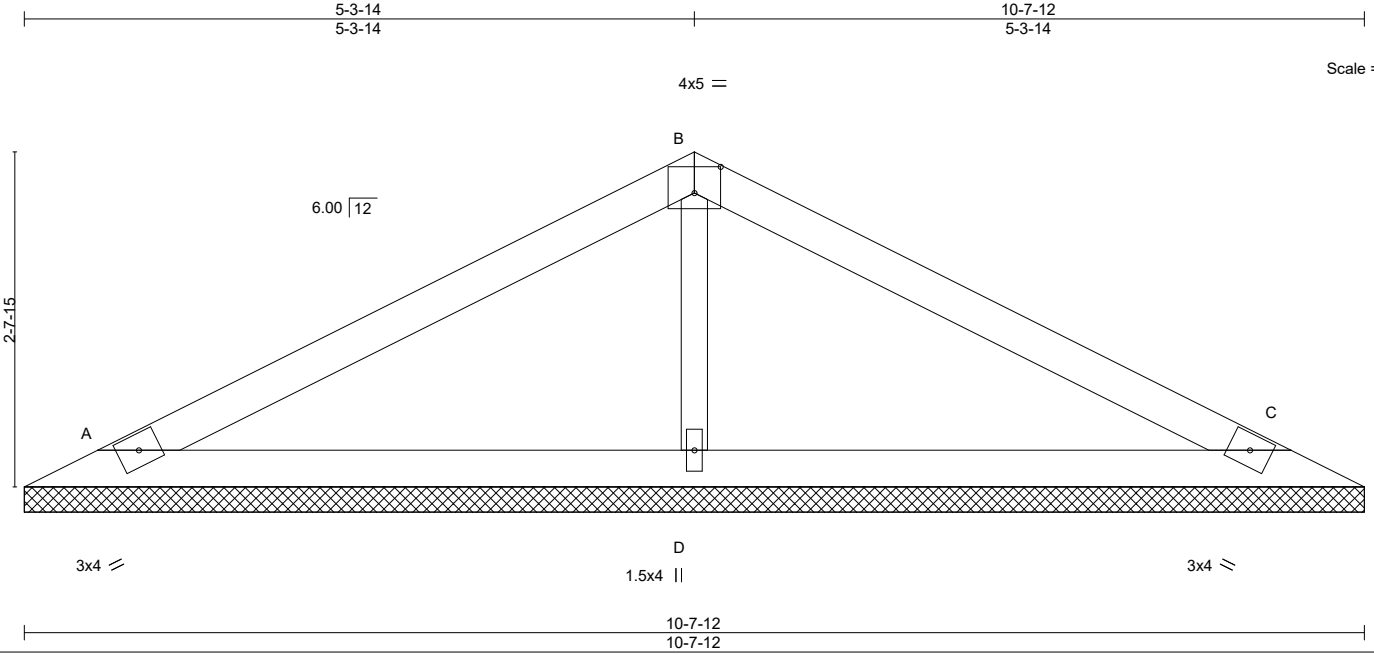

Plate Offsets (X,Y)-- [B:0-2-8,0-2-8]

LOADING (psf)	SPACING-	CSI.	DEFL.	in (loc)	l/defl	L/d	PLATES	GRIP
TCLL 25.0 (Roof Snow=25.0)	2-0-0 Plate Grip DOL 1.15	TC 0.48	Vert(LL)	n/a	-	n/a	MT20	197/144
TCDL 12.0	Lumber DOL 1.15	BC 0.19	Vert(CT)	n/a	-	n/a		
BCLL 0.0 *	Rep Stress Incr YES	WB 0.07	Horz(CT)	0.00	C	n/a		
BCDL 10.0	Code IBC2018/TPI2014	Matrix-S					Weight: 26 lb	FT = 20%

LUMBER-
TOP CHORD 2x4 SPF No.2
BOT CHORD 2x4 SPF No.2
OTHERS 2x3 SPF No.2

BRACING-
TOP CHORD Structural wood sheathing directly applied or 6-0-0 oc purlins.
BOT CHORD Rigid ceiling directly applied or 10-0-0 oc bracing.

REACTIONS. (size) A=10-7-12, C=10-7-12, D=10-7-12
Max Horz A=31(LC 14)
Max Uplift A=-29(LC 10), C=-35(LC 11), D=-14(LC 10)
Max Grav A=296(LC 16), C=296(LC 17), D=474(LC 17)

FORCES. (lb) - Max. Comp./Max. Ten. - All forces 250 (lb) or less except when shown.
WEBS B-D=-329/61

- NOTES-**
- 1) Wind: ASCE 7-16; Vult=115mph (3-second gust) Vasd=91mph; TCDL=4.2psf; BCDL=5.0psf; h=30ft; Ke=1.00; Cat. II; Exp B; Enclosed; MWFRS (envelope) gable end zone; cantilever left and right exposed; end vertical left and right exposed; Lumber DOL=1.33 plate grip DOL=1.33
 - 2) TCLL: ASCE 7-16; Pf=25.0 psf (Lum DOL=1.15 Plate DOL=1.15); Is=1.0; Rough Cat B; Partially Exp.; Ce=1.0; Cs=1.00; Ct=1.10
 - 3) Unbalanced snow loads have been considered for this design.
 - 4) Gable requires continuous bottom chord bearing.
 - 5) This truss has been designed for a 10.0 psf bottom chord live load nonconcurrent with any other live loads.
 - 6) * This truss has been designed for a live load of 20.0psf on the bottom chord in all areas where a rectangle 3-6-0 tall by 2-0-0 wide will fit between the bottom chord and any other members.
 - 7) Provide mechanical connection (by others) of truss to bearing plate capable of withstanding 100 lb uplift at joint(s) A, C, D.
 - 8) This truss is designed in accordance with the 2018 International Building Code section 2306.1 and referenced standard ANSI/TPI 1.



September 12, 2024

WARNING - Verify design parameters and READ NOTES ON THIS AND INCLUDED MITEK REFERENCE PAGE MII-7473 rev. 6/30/2020 BEFORE USE.

Design valid for use only with MiTek® connectors. This design is based only upon parameters shown, and is for an individual building component, not a truss system. Before use, the building designer must verify the applicability of design parameters and properly incorporate this design into the overall building design. Bracing indicated is to prevent buckling of individual truss web and/or chord members only. Additional temporary and permanent bracing is always required for stability and to prevent collapse with possible personal injury and property damage. For general guidance regarding the fabrication, storage, delivery, erection and bracing of trusses and truss systems, see

Safety Information available from Truss Plate Institute, 2670 Crain Highway, Suite 203 Waldorf, MD 20601

ANSI/TPI1 Quality Criteria, DSB-89 and BCSI Building Component



240 Stirling Crescent
Bradford, ON. L3Z 4L5

Job	Truss	Truss Type	Qty	Ply	Buildings A-H	U1530808
N0653A	VR3	Valley	1	1		

Alliance Truss (CA), Abbotsford, BC - V2S 7P6,

8.630 s Jul 12 2024 MiTek Industries, Inc. Thu Sep 12 02:47:49 2024 Page 1

ID:hFyjDMxrTsEK_kgkR0vWWVzFfgc-RfC?PsB70Hq3NSgPqnL8w3ulTXbGKWrCDoi7J4zJC?f

Job Reference (optional)

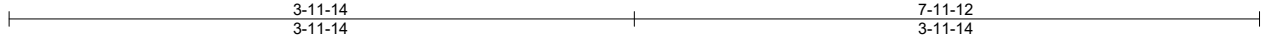

Scale = 1:14.7

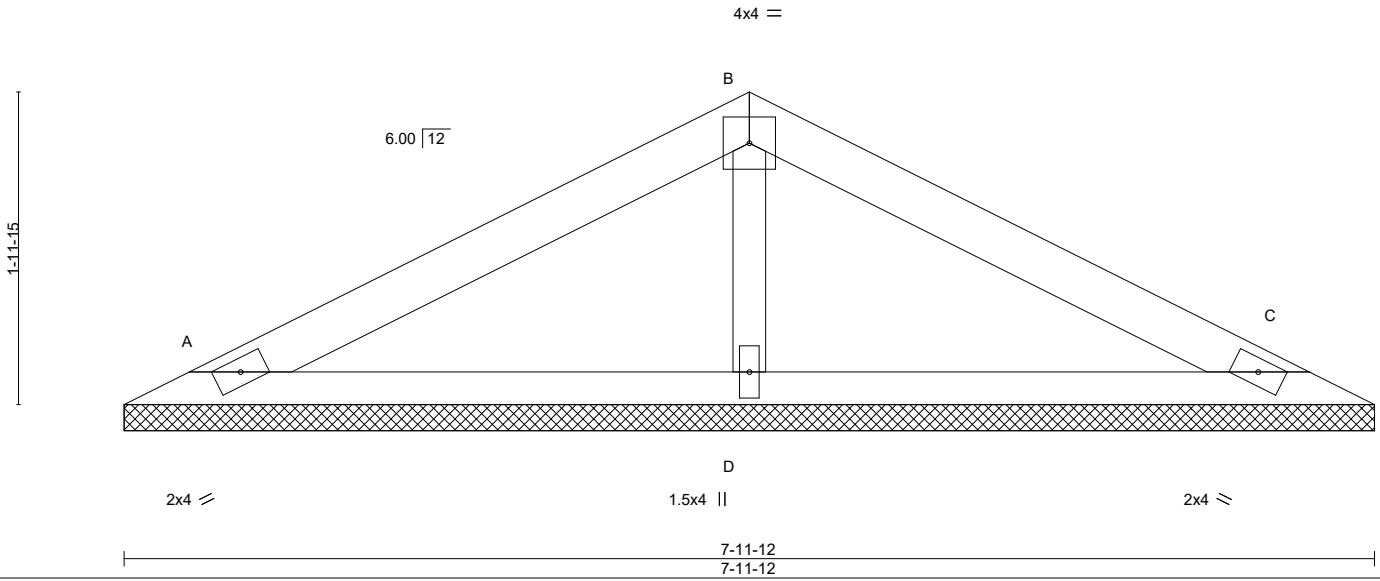

LOADING (psf)	SPACING-	CSI.	DEFL.	PLATES	GRIP
TCLL 25.0 (Roof Snow=25.0)	2-0-0 Plate Grip DOL 1.15 Lumber DOL 1.15	TC 0.33 BC 0.20 WB 0.04 Matrix-P	in (loc) l/defl L/d Vert(LL) n/a - n/a 999 Vert(CT) n/a - n/a 999 Horz(CT) 0.00 C n/a n/a	MT20	197/144
TCDL 12.0 BCLL 0.0 * BCDL 10.0	Rep Stress Incr YES Code IBC2018/TPI2014			Weight: 17 lb	FT = 20%

LUMBER-
TOP CHORD 2x4 SPF No.2
BOT CHORD 2x3 SPF No.2
OTHERS 2x3 SPF No.2

BRACING-
TOP CHORD Structural wood sheathing directly applied or 6-0-0 oc purlins.
BOT CHORD Rigid ceiling directly applied or 10-0-0 oc bracing.

REACTIONS. (size) A=7-11-12, C=7-11-12, D=7-11-12
Max Horz A=23(LC 10)
Max Uplift A=-27(LC 10), C=-32(LC 11)
Max Grav A=223(LC 16), C=223(LC 17), D=314(LC 1)

FORCES. (lb) - Max. Comp./Max. Ten. - All forces 250 (lb) or less except when shown.

- NOTES-**
- 1) Wind: ASCE 7-16; Vult=115mph (3-second gust) Vasd=91mph; TCDL=4.2psf; BCDL=5.0psf; h=30ft; Ke=1.00; Cat. II; Exp B; Enclosed; MWFRS (envelope) gable end zone; cantilever left and right exposed; end vertical left and right exposed; Lumber DOL=1.33 plate grip DOL=1.33
 - 2) TCLL: ASCE 7-16; Pf=25.0 psf (Lum DOL=1.15 Plate DOL=1.15); Is=1.0; Rough Cat B; Partially Exp.; Ce=1.0; Cs=1.00; Ct=1.10
 - 3) Unbalanced snow loads have been considered for this design.
 - 4) Gable requires continuous bottom chord bearing.
 - 5) This truss has been designed for a 10.0 psf bottom chord live load nonconcurrent with any other live loads.
 - 6) * This truss has been designed for a live load of 20.0psf on the bottom chord in all areas where a rectangle 3-6-0 tall by 2-0-0 wide will fit between the bottom chord and any other members.
 - 7) Provide mechanical connection (by others) of truss to bearing plate capable of withstanding 100 lb uplift at joint(s) A, C.
 - 8) This truss is designed in accordance with the 2018 International Building Code section 2306.1 and referenced standard ANSI/TPI 1.



September 12, 2024

WARNING - Verify design parameters and READ NOTES ON THIS AND INCLUDED MITEK REFERENCE PAGE MII-7473 rev. 6/30/2020 BEFORE USE.
Design valid for use only with MiTek® connectors. This design is based only upon parameters shown, and is for an individual building component, not a truss system. Before use, the building designer must verify the applicability of design parameters and properly incorporate this design into the overall building design. Bracing indicated is to prevent buckling of individual truss web and/or chord members only. Additional temporary and permanent bracing is always required for stability and to prevent collapse with possible personal injury and property damage. For general guidance regarding the fabrication, storage, delivery, erection and bracing of trusses and truss systems, see **ANSI/TPI1 Quality Criteria, DSB-89 and BCSI Building Component Safety Information** available from Truss Plate Institute, 2670 Crain Highway, Suite 203 Waldorf, MD 20601



Job	Truss	Truss Type	Qty	Ply	Buildings A-H	U1530809
N0653A	VR4	Valley	1	1		

Alliance Truss (CA), Abbotsford, BC - V2S 7P6,

8.630 s Jul 12 2024 MiTek Industries, Inc. Thu Sep 12 02:47:49 2024 Page 1

ID:hFyjDMxrTsEK_kgkR0vWWVzF1gc-RfC?PsB70Hq3NSgPqnL8w3ulTXbGKWrCDoi7J4zJC?f



4x4 =

Scale = 1:11.1

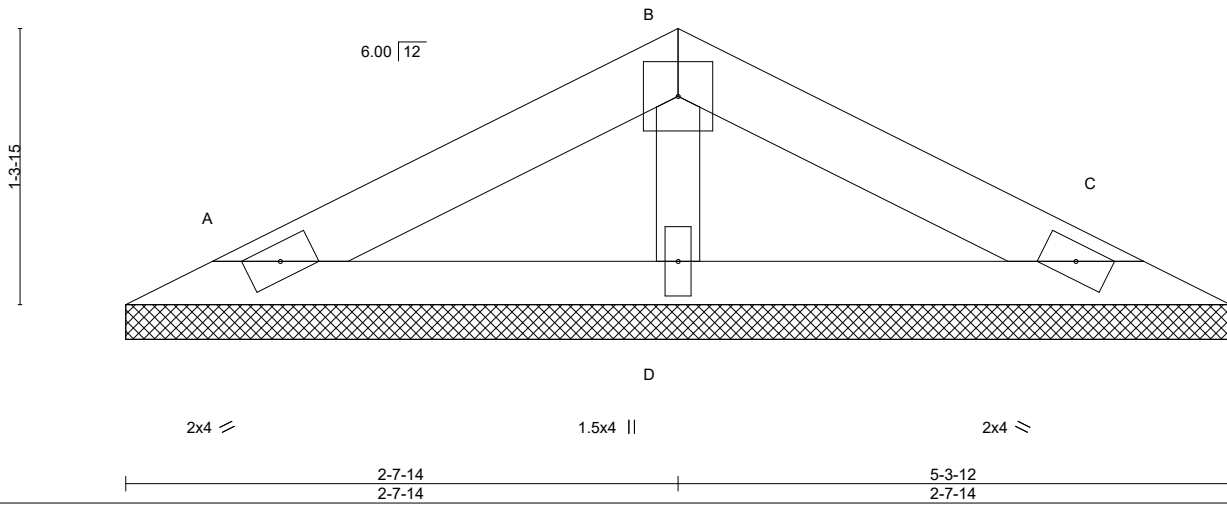

LOADING (psf)	SPACING-	CSI.	DEFL.	PLATES	GRIP
TCLL 25.0	2-0-0	TC 0.11	in (loc) l/defl L/d	MT20	197/144
(Roof Snow=25.0)	Plate Grip DOL 1.15	BC 0.08	Vert(LL) n/a - n/a 999		
TCDL 12.0	Lumber DOL 1.15	WB 0.02	Vert(CT) n/a - n/a 999		
BCLL 0.0 *	Rep Stress Incr YES	Matrix-P	Horz(CT) 0.00 C n/a n/a		
BCDL 10.0	Code IBC2018/TPI2014			Weight: 11 lb	FT = 20%

LUMBER-

TOP CHORD 2x4 SPF No.2
 BOT CHORD 2x3 SPF No.2
 WEBS 2x3 SPF No.2

BRACING-

TOP CHORD Structural wood sheathing directly applied or 5-3-12 oc purlins.
 BOT CHORD Rigid ceiling directly applied or 10-0-0 oc bracing.

REACTIONS.

(size) A=5-3-12, C=5-3-12, D=5-3-12
 Max Horz A=14(LC 14)
 Max Uplift A=-17(LC 10), C=-20(LC 11)
 Max Grav A=129(LC 16), C=129(LC 17), D=193(LC 1)

FORCES. (lb) - Max. Comp./Max. Ten. - All forces 250 (lb) or less except when shown.

NOTES-

- 1) Wind: ASCE 7-16; Vult=115mph (3-second gust) Vasd=91mph; TCDL=4.2psf; BCDL=5.0psf; h=30ft; Ke=1.00; Cat. II; Exp B; Enclosed; MWFRS (envelope) gable end zone; cantilever left and right exposed; end vertical left and right exposed; Lumber DOL=1.33 plate grip DOL=1.33
- 2) TCLL: ASCE 7-16; Pf=25.0 psf (Lum DOL=1.15 Plate DOL=1.15); Is=1.0; Rough Cat B; Partially Exp.; Ce=1.0; Cs=1.00; Ct=1.10
- 3) Unbalanced snow loads have been considered for this design.
- 4) Gable requires continuous bottom chord bearing.
- 5) This truss has been designed for a 10.0 psf bottom chord live load nonconcurrent with any other live loads.
- 6) * This truss has been designed for a live load of 20.0psf on the bottom chord in all areas where a rectangle 3-6-0 tall by 2-0-0 wide will fit between the bottom chord and any other members.
- 7) Provide mechanical connection (by others) of truss to bearing plate capable of withstanding 100 lb uplift at joint(s) A, C.
- 8) This truss is designed in accordance with the 2018 International Building Code section 2306.1 and referenced standard ANSI/TPI 1.



September 12, 2024

WARNING - Verify design parameters and READ NOTES ON THIS AND INCLUDED MITEK REFERENCE PAGE MII-7473 rev. 6/30/2020 BEFORE USE.

Design valid for use only with MiTek® connectors. This design is based only upon parameters shown, and is for an individual building component, not a truss system. Before use, the building designer must verify the applicability of design parameters and properly incorporate this design into the overall building design. Bracing indicated is to prevent buckling of individual truss web and/or chord members only. Additional temporary and permanent bracing is always required for stability and to prevent collapse with possible personal injury and property damage. For general guidance regarding the fabrication, storage, delivery, erection and bracing of trusses and truss systems, see

ANSI/TPI1 Quality Criteria, DSB-89 and BCSI Building Component

Safety Information available from Truss Plate Institute, 2670 Crain Highway, Suite 203 Waldorf, MD 20601



240 Stirling Crescent
 Bradford, ON. L3Z 4L5

Job	Truss	Truss Type	Qty	Ply	Buildings A-H	U1530887
N0653A	VU1	Valley	20	1		

Alliance Truss (CA), Abbotsford, BC - V2S 7P6,

8.820 s Aug 30 2024 MiTek Industries, Inc. Thu Sep 12 02:48:35 2024 Page 1

ID:hFyjDMxrTsEK_kgkR0vWWVzFgC-oHOw?kQRARUM1BZ9oU?1gCjY7X45AWypyhMriyeVqg

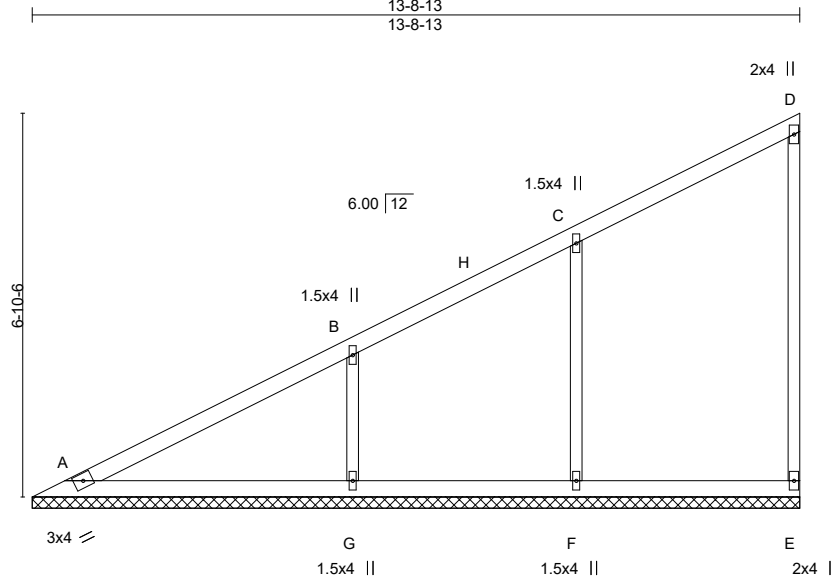

LOADING (psf)	SPACING-	CSI.	DEFL.	PLATES	GRIP
TCLL 25.0	2-0-0	TC 0.34	in (loc) l/defl L/d	MT20	197/144
(Roof Snow=25.0)	Plate Grip DOL 1.15	BC 0.20	Vert(LL) n/a - n/a 999		
TCDL 12.0	Lumber DOL 1.15	WB 0.23	Vert(CT) n/a - n/a 999		
BCLL 0.0 *	Rep Stress Incr YES	Matrix-S	Horz(CT) -0.00 E n/a n/a		
BCDL 10.0	Code IBC2018/TPI2014			Weight: 43 lb	FT = 20%

LUMBER-

TOP CHORD 2x4 SPF No.2
 BOT CHORD 2x4 SPF No.2
 WEBS 2x3 SPF No.2
 OTHERS 2x3 SPF No.2

BRACING-

TOP CHORD Structural wood sheathing directly applied or 6-0-0 oc purlins, except end verticals.
 BOT CHORD Rigid ceiling directly applied or 10-0-0 oc bracing.

REACTIONS.

All bearings 13-8-13.
 (lb) - Max Horz A=201(LC 7)
 Max Uplift All uplift 100 lb or less at joint(s) E, F except G=-103(LC 10)
 Max Grav All reactions 250 lb or less at joint(s) A, E except F=528(LC 3), G=509(LC 3)

FORCES. (lb) - Max. Comp./Max. Ten. - All forces 250 (lb) or less except when shown.

WEBS C-F=-446/107, B-G=-381/150

NOTES-

- 1) Wind: ASCE 7-16; Vult=115mph (3-second gust) Vasd=91mph; TCDL=4.2psf; BCDL=5.0psf; h=30ft; Ke=1.00; Cat. II; Exp B; Enclosed; MWFRS (envelope) gable end zone; cantilever left and right exposed; end vertical left and right exposed; Lumber DOL=1.33 plate grip DOL=1.33
- 2) TCLL: ASCE 7-16; Pf=25.0 psf (Lum DOL = 1.15 Plate DOL = 1.15); Is=1.0; Rough Cat B; Partially Exp.; Ce=1.0; Cs=1.00; Ct=1.10
- 3) Unbalanced snow loads have been considered for this design.
- 4) Gable requires continuous bottom chord bearing.
- 5) This truss has been designed for a 10.0 psf bottom chord live load nonconcurrent with any other live loads.
- 6) * This truss has been designed for a live load of 20.0psf on the bottom chord in all areas where a rectangle 3-6-0 tall by 2-0-0 wide will fit between the bottom chord and any other members, with BCDL = 10.0psf.
- 7) Provide mechanical connection (by others) of truss to bearing plate capable of withstanding 100 lb uplift at joint(s) E, F except (jt=lb) G=103.
- 8) This truss is designed in accordance with the 2018 International Building Code section 2306.1 and referenced standard ANSI/TPI 1.



September 12, 2024

WARNING - Verify design parameters and READ NOTES ON THIS AND INCLUDED MITEK REFERENCE PAGE MII-7473 rev. 6/30/2020 BEFORE USE.

Design valid for use only with MiTek® connectors. This design is based only upon parameters shown, and is for an individual building component, not a truss system. Before use, the building designer must verify the applicability of design parameters and properly incorporate this design into the overall building design. Bracing indicated is to prevent buckling of individual truss web and/or chord members only. Additional temporary and permanent bracing is always required for stability and to prevent collapse with possible personal injury and property damage. For general guidance regarding the fabrication, storage, delivery, erection and bracing of trusses and truss systems, see

ANSI/TPI1 Quality Criteria, DSB-89 and BCSI Building Component Safety Information available from Truss Plate Institute, 2670 Crain Highway, Suite 203 Waldorf, MD 20601



240 Stirling Crescent
 Bradford, ON. L3Z 4L5

Job	Truss	Truss Type	Qty	Ply	Buildings A-H	U1530888
N0653A	VU2	Valley	20	1		

Alliance Truss (CA), Abbotsford, BC - V2S 7P6,

8.820 s Aug 30 2024 MiTek Industries, Inc. Thu Sep 12 02:48:35 2024 Page 1

ID:hFyjDMxrTsEK_kgkR0vWWVzFIgc-oHOw?kQRarUM1BZ9oU?1gCjZjX5wAXjpyhMrriyvqg

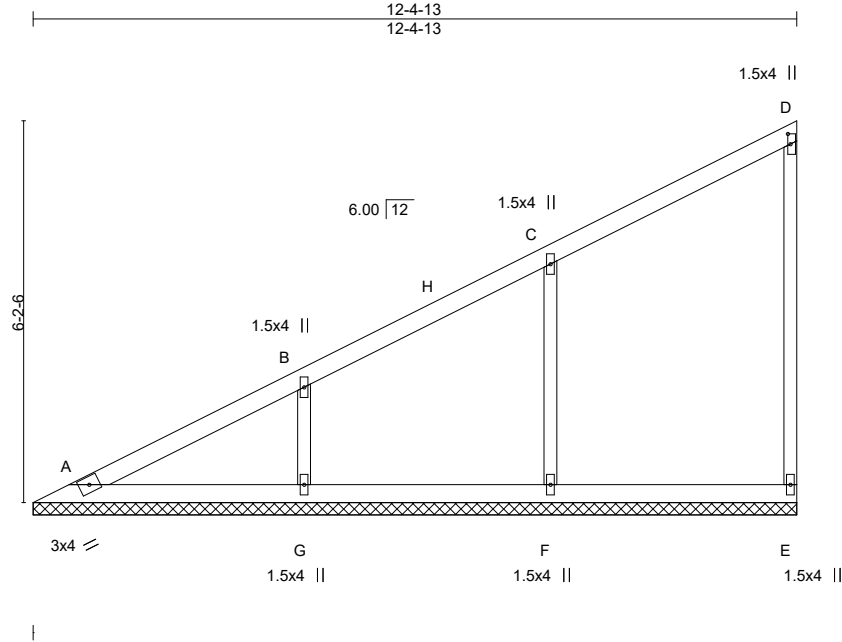

Scale = 1:37.4

Plate Offsets (X,Y)-- [D:0-2-0,0-0-8]

LOADING (psf)	SPACING-	CSI.	DEFL.	in (loc)	l/defl	L/d	PLATES	GRIP
TCLL 25.0 (Roof Snow=25.0)	2-0-0 Plate Grip DOL 1.15	TC 0.30	Vert(LL)	n/a	-	n/a	MT20	197/144
TCDL 12.0	Lumber DOL 1.15	BC 0.14	Vert(CT)	n/a	-	n/a		
BCLL 0.0 *	Rep Stress Incr YES	WB 0.18	Horz(CT)	-0.00	E	n/a		
BCDL 10.0	Code IBC2018/TPI2014	Matrix-S					Weight: 38 lb	FT = 20%

LUMBER-

TOP CHORD 2x4 SPF No.2
 BOT CHORD 2x4 SPF No.2
 WEBS 2x3 SPF No.2
 OTHERS 2x3 SPF No.2

BRACING-

TOP CHORD Structural wood sheathing directly applied or 6-0-0 oc purlins, except end verticals.
 BOT CHORD Rigid ceiling directly applied or 10-0-0 oc bracing.

REACTIONS.

All bearings 12-4-13.
 (lb) - Max Horz A=180(LC 7)
 Max Uplift All uplift 100 lb or less at joint(s) E, F, G
 Max Grav All reactions 250 lb or less at joint(s) A, E except F=562(LC 3), G=409(LC 3)

FORCES. (lb) - Max. Comp./Max. Ten. - All forces 250 (lb) or less except when shown.

WEBS C-F=-469/118, B-G=-310/123

NOTES-

- 1) Wind: ASCE 7-16; Vult=115mph (3-second gust) Vasd=91mph; TCDL=4.2psf; BCDL=5.0psf; h=30ft; Ke=1.00; Cat. II; Exp B; Enclosed; MWFRS (envelope) gable end zone; cantilever left and right exposed; end vertical left and right exposed; Lumber DOL=1.33 plate grip DOL=1.33
- 2) TCLL: ASCE 7-16; Pf=25.0 psf (Lum DOL = 1.15 Plate DOL = 1.15); Is=1.0; Rough Cat B; Partially Exp.; Ce=1.0; Cs=1.00; Ct=1.10
- 3) Unbalanced snow loads have been considered for this design.
- 4) Gable requires continuous bottom chord bearing.
- 5) This truss has been designed for a 10.0 psf bottom chord live load nonconcurrent with any other live loads.
- 6) * This truss has been designed for a live load of 20.0psf on the bottom chord in all areas where a rectangle 3-6-0 tall by 2-0-0 wide will fit between the bottom chord and any other members, with BCDL = 10.0psf.
- 7) Provide mechanical connection (by others) of truss to bearing plate capable of withstanding 100 lb uplift at joint(s) E, F, G.
- 8) This truss is designed in accordance with the 2018 International Building Code section 2306.1 and referenced standard ANSI/TPI 1.



September 12, 2024

WARNING - Verify design parameters and READ NOTES ON THIS AND INCLUDED MITEK REFERENCE PAGE MII-7473 rev. 6/30/2020 BEFORE USE.

Design valid for use only with MiTek® connectors. This design is based only upon parameters shown, and is for an individual building component, not a truss system. Before use, the building designer must verify the applicability of design parameters and properly incorporate this design into the overall building design. Bracing indicated is to prevent buckling of individual truss web and/or chord members only. Additional temporary and permanent bracing is always required for stability and to prevent collapse with possible personal injury and property damage. For general guidance regarding the fabrication, storage, delivery, erection and bracing of trusses and truss systems, see

Safety Information available from Truss Plate Institute, 2670 Crain Highway, Suite 203 Waldorf, MD 20601



240 Stirling Crescent
 Bradford, ON. L3Z 4L5

Job	Truss	Truss Type	Qty	Ply	Buildings A-H	U1530889
N0653A	VU3	Valley	20	1		

Alliance Truss (CA), Abbotsford, BC - V2S 7P6,

8.820 s Aug 30 2024 MiTek Industries, Inc. Thu Sep 12 02:48:36 2024 Page 1

ID:hFyjDMxrTsEK_kgkR0vWWVzF1gc-GUyIC4Q3x8cDeL8LMBWGCQFkExRHv_eyBL6ON9yeVqf

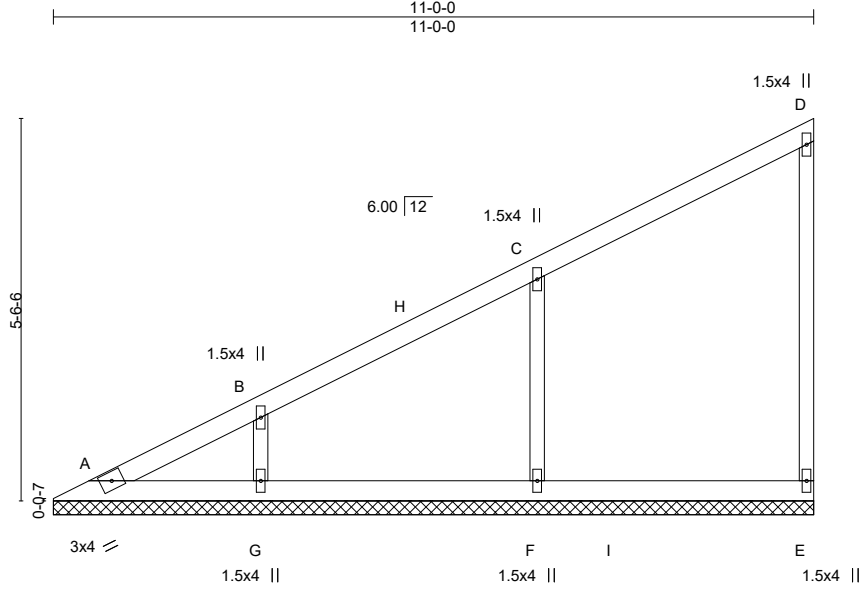

Scale = 1:33.3

LOADING (psf)	SPACING-	2-0-0	CSI.	DEFL.	in (loc)	l/defl	L/d	PLATES	GRIP
TCLL 25.0	Plate Grip DOL	1.15	TC 0.32	Vert(LL)	n/a	-	n/a	MT20	197/144
(Roof Snow=25.0)	Lumber DOL	1.15	BC 0.14	Vert(CT)	n/a	-	n/a		
TCDL 12.0	Rep Stress Incr	YES	WB 0.14	Horz(CT)	-0.00	E	n/a		
BCLL 0.0 *	Code IBC2018/TPI2014		Matrix-S					Weight: 33 lb	FT = 20%
BCDL 10.0									

LUMBER-

TOP CHORD 2x4 SPF No.2
 BOT CHORD 2x4 SPF No.2
 WEBS 2x3 SPF No.2
 OTHERS 2x3 SPF No.2

BRACING-

TOP CHORD Structural wood sheathing directly applied or 6-0-0 oc purlins, except end verticals.
 BOT CHORD Rigid ceiling directly applied or 10-0-0 oc bracing.

REACTIONS.

All bearings 11-0-0.
 (lb) - Max Horz A=159(LC 9)
 Max Uplift All uplift 100 lb or less at joint(s) E, F, G
 Max Grav All reactions 250 lb or less at joint(s) A, E except F=569(LC 16), G=333(LC 3)

FORCES. (lb) - Max. Comp./Max. Ten. - All forces 250 (lb) or less except when shown.

WEBS C-F=-481/125, B-G=-256/103

NOTES-

- 1) Wind: ASCE 7-16; Vult=115mph (3-second gust) Vasd=91mph; TCDL=4.2psf; BCDL=5.0psf; h=30ft; Ke=1.00; Cat. II; Exp B; Enclosed; MWFRS (envelope) gable end zone; cantilever left and right exposed ; end vertical left and right exposed; Lumber DOL=1.33 plate grip DOL=1.33
- 2) TCLL: ASCE 7-16; Pf=25.0 psf (Lum DOL = 1.15 Plate DOL = 1.15); Is=1.0; Rough Cat B; Partially Exp.; Ce=1.0; Cs=1.00; Ct=1.10
- 3) Unbalanced snow loads have been considered for this design.
- 4) Gable requires continuous bottom chord bearing.
- 5) This truss has been designed for a 10.0 psf bottom chord live load nonconcurrent with any other live loads.
- 6) * This truss has been designed for a live load of 20.0psf on the bottom chord in all areas where a rectangle 3-6-0 tall by 2-0-0 wide will fit between the bottom chord and any other members, with BCDL = 10.0psf.
- 7) Provide mechanical connection (by others) of truss to bearing plate capable of withstanding 100 lb uplift at joint(s) E, F, G.
- 8) This truss is designed in accordance with the 2018 International Building Code section 2306.1 and referenced standard ANSI/TPI 1.



September 12, 2024

WARNING - Verify design parameters and READ NOTES ON THIS AND INCLUDED MITEK REFERENCE PAGE MII-7473 rev. 6/30/2020 BEFORE USE.

Design valid for use only with MiTek® connectors. This design is based only upon parameters shown, and is for an individual building component, not a truss system. Before use, the building designer must verify the applicability of design parameters and properly incorporate this design into the overall building design. Bracing indicated is to prevent buckling of individual truss web and/or chord members only. Additional temporary and permanent bracing is always required for stability and to prevent collapse with possible personal injury and property damage. For general guidance regarding the fabrication, storage, delivery, erection and bracing of trusses and truss systems, see

ANSI/TPI1 Quality Criteria, DSB-89 and BCSI Building Component

Safety Information available from Truss Plate Institute, 2670 Crain Highway, Suite 203 Waldorf, MD 20601



240 Stirling Crescent
 Bradford, ON. L3Z 4L5

Job	Truss	Truss Type	Qty	Ply	Buildings A-H	U1530890
N0653A	VU4	Valley	20	1		

Alliance Truss (CA), Abbotsford, BC - V2S 7P6,

8.820 s Aug 30 2024 MiTek Industries, Inc. Thu Sep 12 02:48:36 2024 Page 1

ID:hFyjDMxrTsEK_kgkR0vWWVzFJgc-GUylC4Q3x8cDeL8LMBWGCQFh2xOvv_myBL6ON9yeVqf
9-8-13
9-8-13

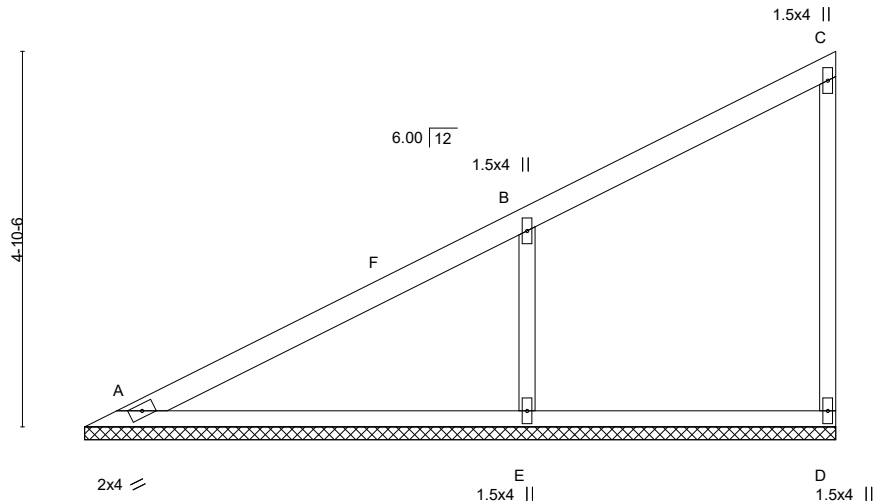

Scale = 1:29.9

LOADING (psf)	SPACING-	CSI.	DEFL.	in (loc)	l/defl	L/d	PLATES	GRIP
TCLL 25.0	2-0-0	TC 0.46	Vert(LL)	n/a	-	n/a	MT20	197/144
(Roof Snow=25.0)	Plate Grip DOL 1.15	BC 0.35	Vert(CT)	n/a	-	n/a		
TCDL 12.0	Lumber DOL 1.15	WB 0.13	Horz(CT)	-0.00	D	n/a		
BCLL 0.0 *	Rep Stress Incr YES	Matrix-S						
BCDL 10.0	Code IBC2018/TPI2014						Weight: 25 lb	FT = 20%

LUMBER-

TOP CHORD 2x4 SPF No.2
BOT CHORD 2x3 SPF No.2
WEBS 2x3 SPF No.2
OTHERS 2x3 SPF No.2

BRACING-

TOP CHORD Structural wood sheathing directly applied or 6-0-0 oc purlins, except end verticals.
BOT CHORD Rigid ceiling directly applied or 10-0-0 oc bracing.

REACTIONS.

(size) A=9-8-13, D=9-8-13, E=9-8-13
Max Horz A=140(LC 7)
Max Uplift D=-19(LC 7), E=-110(LC 10)
Max Grav A=198(LC 16), D=182(LC 16), E=688(LC 16)

FORCES. (lb) - Max. Comp./Max. Ten. - All forces 250 (lb) or less except when shown.

WEBS B-E=-571/157

NOTES-

- 1) Wind: ASCE 7-16; Vult=115mph (3-second gust) Vasd=91mph; TCDL=4.2psf; BCDL=5.0psf; h=30ft; Ke=1.00; Cat. II; Exp B; Enclosed; MWFRS (envelope) gable end zone; cantilever left and right exposed; end vertical left and right exposed; Lumber DOL=1.33 plate grip DOL=1.33
- 2) TCLL: ASCE 7-16; Pf=25.0 psf (Lum DOL = 1.15 Plate DOL = 1.15); Is=1.0; Rough Cat B; Partially Exp.; Ce=1.0; Cs=1.00; Ct=1.10
- 3) Unbalanced snow loads have been considered for this design.
- 4) Gable requires continuous bottom chord bearing.
- 5) This truss has been designed for a 10.0 psf bottom chord live load nonconcurrent with any other live loads.
- 6) * This truss has been designed for a live load of 20.0psf on the bottom chord in all areas where a rectangle 3-6-0 tall by 2-0-0 wide will fit between the bottom chord and any other members.
- 7) Provide mechanical connection (by others) of truss to bearing plate capable of withstanding 100 lb uplift at joint(s) D except (jt=lb) E=110.
- 8) This truss is designed in accordance with the 2018 International Building Code section 2306.1 and referenced standard ANSI/TPI 1.



September 12, 2024

WARNING - Verify design parameters and READ NOTES ON THIS AND INCLUDED MITEK REFERENCE PAGE MII-7473 rev. 6/30/2020 BEFORE USE.

Design valid for use only with MiTek® connectors. This design is based only upon parameters shown, and is for an individual building component, not a truss system. Before use, the building designer must verify the applicability of design parameters and properly incorporate this design into the overall building design. Bracing indicated is to prevent buckling of individual truss web and/or chord members only. Additional temporary and permanent bracing is always required for stability and to prevent collapse with possible personal injury and property damage. For general guidance regarding the fabrication, storage, delivery, erection and bracing of trusses and truss systems, see

ANSI/TPI1 Quality Criteria, DSB-89 and BCSI Building Component Safety Information available from Truss Plate Institute, 2670 Crain Highway, Suite 203 Waldorf, MD 20601



240 Stirling Crescent
Bradford, ON. L3Z 4L5

Job	Truss	Truss Type	Qty	Ply	Buildings A-H	U1530891
N0653A	VU5	Valley	20	1		

Alliance Truss (CA), Abbotsford, BC - V2S 7P6, 8.820 s Aug 30 2024 MiTek Industries, Inc. Thu Sep 12 02:48:37 2024 Page 1

ID:hFyjDMxrTsEK_kgkR0vWWWzF1gc-kgWgPQRhhSk4GVjXvv1VldouPLmoesSW6P?rybyVqe
8-4-13
8-4-13

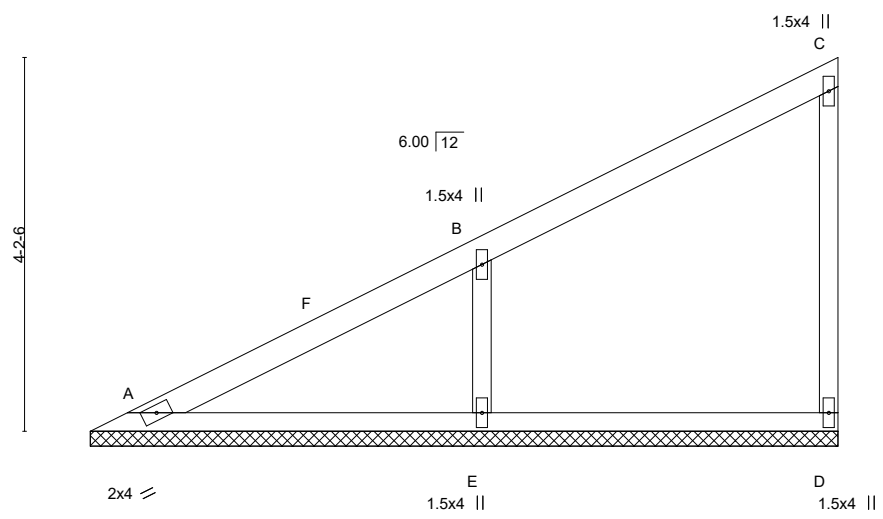

Scale = 1:25.9

LOADING (psf)	SPACING-	CSI.	DEFL.	PLATES	GRIP
TCLL 25.0 (Roof Snow=25.0)	2-0-0	TC 0.36	in (loc) l/defl L/d	MT20	197/144
TCDL 12.0	Plate Grip DOL 1.15	BC 0.25	Vert(LL) n/a - n/a 999		
BCLL 0.0 *	Lumber DOL 1.15	WB 0.10	Vert(CT) n/a - n/a 999		
BCDL 10.0	Rep Stress Incr YES	Matrix-P	Horz(CT) -0.00 D n/a n/a	Weight: 21 lb	FT = 20%
	Code IBC2018/TPI2014				

LUMBER-

TOP CHORD 2x4 SPF No.2
BOT CHORD 2x3 SPF No.2
WEBS 2x3 SPF No.2
OTHERS 2x3 SPF No.2

BRACING-

TOP CHORD Structural wood sheathing directly applied or 6-0-0 oc purlins, except end verticals.
BOT CHORD Rigid ceiling directly applied or 10-0-0 oc bracing.

REACTIONS.

(size) A=8-4-13, D=8-4-13, E=8-4-13
Max Horz A=120(LC 7)
Max Uplift D=-19(LC 7), E=-94(LC 10)
Max Grav A=136(LC 16), D=199(LC 16), E=607(LC 16)

FORCES. (lb) - Max. Comp./Max. Ten. - All forces 250 (lb) or less except when shown.

WEBS B-E=-510/142

NOTES-

- 1) Wind: ASCE 7-16; Vult=115mph (3-second gust) Vasd=91mph; TCDL=4.2psf; BCDL=5.0psf; h=30ft; Ke=1.00; Cat. II; Exp B; Enclosed; MWFRS (envelope) gable end zone; cantilever left and right exposed; end vertical left and right exposed; Lumber DOL=1.33 plate grip DOL=1.33
- 2) TCLL: ASCE 7-16; Pf=25.0 psf (Lum DOL = 1.15 Plate DOL = 1.15); Is=1.0; Rough Cat B; Partially Exp.; Ce=1.0; Cs=1.00; Ct=1.10
- 3) Unbalanced snow loads have been considered for this design.
- 4) Gable requires continuous bottom chord bearing.
- 5) This truss has been designed for a 10.0 psf bottom chord live load nonconcurrent with any other live loads.
- 6) * This truss has been designed for a live load of 20.0psf on the bottom chord in all areas where a rectangle 3-6-0 tall by 2-0-0 wide will fit between the bottom chord and any other members.
- 7) Provide mechanical connection (by others) of truss to bearing plate capable of withstanding 100 lb uplift at joint(s) D, E.
- 8) This truss is designed in accordance with the 2018 International Building Code section 2306.1 and referenced standard ANSI/TPI 1.



September 12, 2024

WARNING - Verify design parameters and READ NOTES ON THIS AND INCLUDED MITEK REFERENCE PAGE MII-7473 rev. 6/30/2020 BEFORE USE.

Design valid for use only with MiTek® connectors. This design is based only upon parameters shown, and is for an individual building component, not a truss system. Before use, the building designer must verify the applicability of design parameters and properly incorporate this design into the overall building design. Bracing indicated is to prevent buckling of individual truss web and/or chord members only. Additional temporary and permanent bracing is always required for stability and to prevent collapse with possible personal injury and property damage. For general guidance regarding the fabrication, storage, delivery, erection and bracing of trusses and truss systems, see

Safety Information available from Truss Plate Institute, 2670 Crain Highway, Suite 203 Waldorf, MD 20601
ANSI/TPI1 Quality Criteria, DSB-89 and BCSI Building Component



240 Stirling Crescent
Bradford, ON. L3Z 4L5

Job	Truss	Truss Type	Qty	Ply	Buildings A-H	U1530892
N0653A	VU6	Valley	20	1		

Alliance Truss (CA), Abbotsford, BC - V2S 7P6,

8.820 s Aug 30 2024 MiTek Industries, Inc. Thu Sep 12 02:48:37 2024 Page 1

ID:hFyjDMxrTsEK_kgkR0vWWVzFlgc-kgWgPQRhhSk4GVjXvv1VldovHLMoeSm6P?rybyveVqe
7-0-0
7-0-0

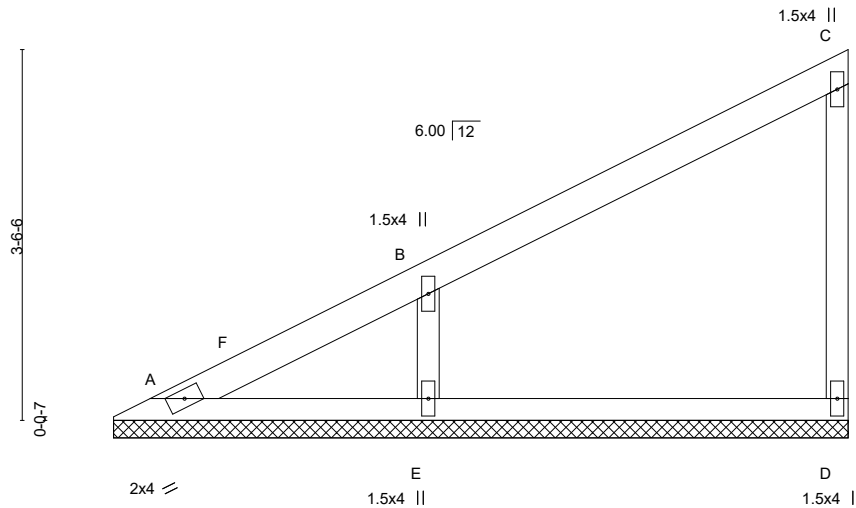

Scale = 1:22.0

LOADING (psf)	SPACING-	2-0-0	CSI.	DEFL.	in (loc)	l/defl	L/d	PLATES	GRIP	
TCLL 25.0	Plate Grip DOL	1.15	TC 0.30	Vert(LL)	n/a	-	n/a	999	MT20	197/144
(Roof Snow=25.0)	Lumber DOL	1.15	BC 0.21	Vert(CT)	n/a	-	n/a	999		
TCDL 12.0	Rep Stress Incr	YES	WB 0.08	Horz(CT)	-0.00	D	n/a	n/a		
BCLL 0.0 *	Code IBC2018/TPI2014		Matrix-P						Weight: 17 lb	FT = 20%
BCDL 10.0										

LUMBER-

TOP CHORD 2x4 SPF No.2
BOT CHORD 2x3 SPF No.2
WEBS 2x3 SPF No.2
OTHERS 2x3 SPF No.2

BRACING-

TOP CHORD Structural wood sheathing directly applied or 6-0-0 oc purlins, except end verticals.
BOT CHORD Rigid ceiling directly applied or 10-0-0 oc bracing.

REACTIONS.

(size) A=7-0-0, D=7-0-0, E=7-0-0
Max Horz A=99(LC 7)
Max Uplift D=-19(LC 10), E=-81(LC 10)
Max Grav A=74(LC 20), D=209(LC 16), E=543(LC 16)

FORCES. (lb) - Max. Comp./Max. Ten. - All forces 250 (lb) or less except when shown.

WEBS B-E=-460/122

NOTES-

- 1) Wind: ASCE 7-16; Vult=115mph (3-second gust) Vasd=91mph; TCDL=4.2psf; BCDL=5.0psf; h=30ft; Ke=1.00; Cat. II; Exp B; Enclosed; MWFRS (envelope) gable end zone; cantilever left and right exposed; end vertical left and right exposed; Lumber DOL=1.33 plate grip DOL=1.33
- 2) TCLL: ASCE 7-16; Pf=25.0 psf (Lum DOL = 1.15 Plate DOL = 1.15); Is=1.0; Rough Cat B; Partially Exp.; Ce=1.0; Cs=1.00; Ct=1.10
- 3) Unbalanced snow loads have been considered for this design.
- 4) Gable requires continuous bottom chord bearing.
- 5) This truss has been designed for a 10.0 psf bottom chord live load nonconcurrent with any other live loads.
- 6) * This truss has been designed for a live load of 20.0psf on the bottom chord in all areas where a rectangle 3-6-0 tall by 2-0-0 wide will fit between the bottom chord and any other members.
- 7) Provide mechanical connection (by others) of truss to bearing plate capable of withstanding 100 lb uplift at joint(s) D, E.
- 8) This truss is designed in accordance with the 2018 International Building Code section 2306.1 and referenced standard ANSI/TPI 1.



September 12, 2024

WARNING - Verify design parameters and READ NOTES ON THIS AND INCLUDED MITEK REFERENCE PAGE MII-7473 rev. 6/30/2020 BEFORE USE.

Design valid for use only with MiTek® connectors. This design is based only upon parameters shown, and is for an individual building component, not a truss system. Before use, the building designer must verify the applicability of design parameters and properly incorporate this design into the overall building design. Bracing indicated is to prevent buckling of individual truss web and/or chord members only. Additional temporary and permanent bracing is always required for stability and to prevent collapse with possible personal injury and property damage. For general guidance regarding the fabrication, storage, delivery, erection and bracing of trusses and truss systems, see

ANSI/TPI1 Quality Criteria, DSB-89 and BCSI Building Component Safety Information available from Truss Plate Institute, 2670 Crain Highway, Suite 203 Waldorf, MD 20601



240 Stirling Crescent
Bradford, ON. L3Z 4L5

Job	Truss	Truss Type	Qty	Ply	Buildings A-H	U1530893
N0653A	VU7	GABLE	20	1		

Alliance Truss (CA), Abbotsford, BC - V2S 7P6,

8.820 s Aug 30 2024 MiTek Industries, Inc. Thu Sep 12 02:48:38 2024 Page 1

ID:hFyjDMxrTsEK_kgkR0vWWVzFlgc-Cs43dmSJSmsxufHkTcYkrlY6i7INwJFeebVS1yeVqd

5-8-13
5-8-13

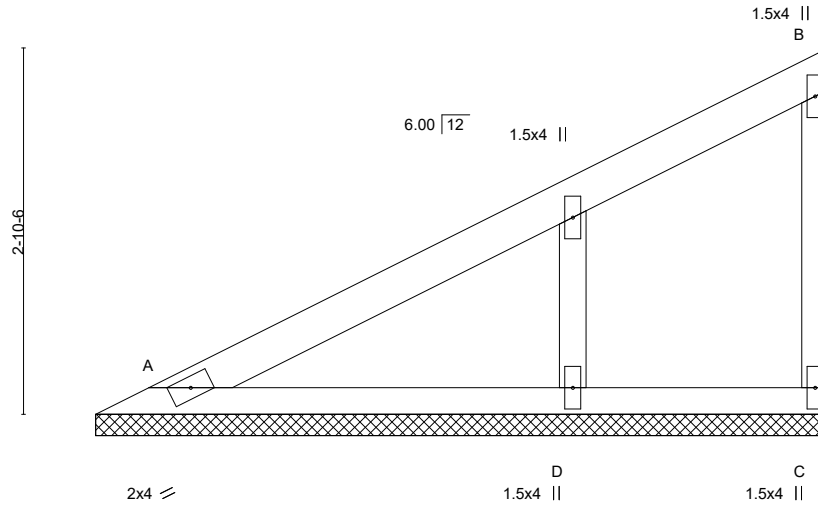

Scale = 1:18.0

LOADING (psf)	SPACING-	CSI.	DEFL.	in (loc)	l/defl	L/d	PLATES	GRIP
TCLL 25.0	2-0-0	TC 0.81	Vert(LL)	n/a	-	n/a	MT20	197/144
(Roof Snow=25.0)	Plate Grip DOL 1.15	BC 0.14	Vert(CT)	n/a	-	n/a		
TCDL 12.0	Lumber DOL 1.15	WB 0.00	Horz(CT)	-0.00	C	n/a		
BCLL 0.0 *	Rep Stress Incr YES	Matrix-P						
BCDL 10.0	Code IBC2018/TPI2014						Weight: 14 lb	FT = 20%

LUMBER-

TOP CHORD 2x4 SPF No.2
BOT CHORD 2x3 SPF No.2
WEBS 2x3 SPF No.2
OTHERS 2x3 SPF No.2

BRACING-

TOP CHORD Structural wood sheathing directly applied or 5-8-13 oc purlins, except end verticals.
BOT CHORD Rigid ceiling directly applied or 10-0-0 oc bracing.

REACTIONS.

(size) A=5-8-13, C=5-8-13, D=5-8-13
Max Horz A=79(LC 9)
Max Uplift A=-33(LC 10), C=-61(LC 10)
Max Grav A=311(LC 16), C=294(LC 16), D=134(LC 5)

FORCES. (lb) - Max. Comp./Max. Ten. - All forces 250 (lb) or less except when shown.

TOP CHORD B-C=-286/65

NOTES-

- 1) Wind: ASCE 7-16; Vult=115mph (3-second gust) Vasd=91mph; TCDL=4.2psf; BCDL=5.0psf; h=30ft; Ke=1.00; Cat. II; Exp B; Enclosed; MWFRS (envelope) gable end zone; cantilever left and right exposed; end vertical left and right exposed; Lumber DOL=1.33 plate grip DOL=1.33
- 2) TCLL: ASCE 7-16; Pf=25.0 psf (Lum DOL = 1.15 Plate DOL = 1.15); Is=1.0; Rough Cat B; Partially Exp.; Ce=1.0; Cs=1.00; Ct=1.10
- 3) Unbalanced snow loads have been considered for this design.
- 4) Gable requires continuous bottom chord bearing.
- 5) This truss has been designed for a 10.0 psf bottom chord live load nonconcurrent with any other live loads.
- 6) * This truss has been designed for a live load of 20.0psf on the bottom chord in all areas where a rectangle 3-6-0 tall by 2-0-0 wide will fit between the bottom chord and any other members.
- 7) Provide mechanical connection (by others) of truss to bearing plate capable of withstanding 100 lb uplift at joint(s) A, C.
- 8) This truss is designed in accordance with the 2018 International Building Code section 2306.1 and referenced standard ANSI/TPI 1.



September 12, 2024

WARNING - Verify design parameters and READ NOTES ON THIS AND INCLUDED MITEK REFERENCE PAGE MII-7473 rev. 6/30/2020 BEFORE USE.

Design valid for use only with MiTek® connectors. This design is based only upon parameters shown, and is for an individual building component, not a truss system. Before use, the building designer must verify the applicability of design parameters and properly incorporate this design into the overall building design. Bracing indicated is to prevent buckling of individual truss web and/or chord members only. Additional temporary and permanent bracing is always required for stability and to prevent collapse with possible personal injury and property damage. For general guidance regarding the fabrication, storage, delivery, erection and bracing of trusses and truss systems, see

ANSI/TPI1 Quality Criteria, DSB-89 and BCSI Building Component Safety Information available from Truss Plate Institute, 2670 Crain Highway, Suite 203 Waldorf, MD 20601



240 Stirling Crescent
Bradford, ON. L3Z 4L5

Job	Truss	Truss Type	Qty	Ply	Buildings A-H	U1530894
N0653A	VU8	Valley	20	1		

Alliance Truss (CA), Abbotsford, BC - V2S 7P6,

8.820 s Aug 30 2024 MiTek Industries, Inc. Thu Sep 12 02:48:38 2024 Page 1

ID:hFyjDMxrTsEK_kgkR0vWWWzF1gc-Cs43dmSJSmsxufHKtCYklrL2SI5KNwJFeebVS1yeVqd

4-4-13
4-4-13

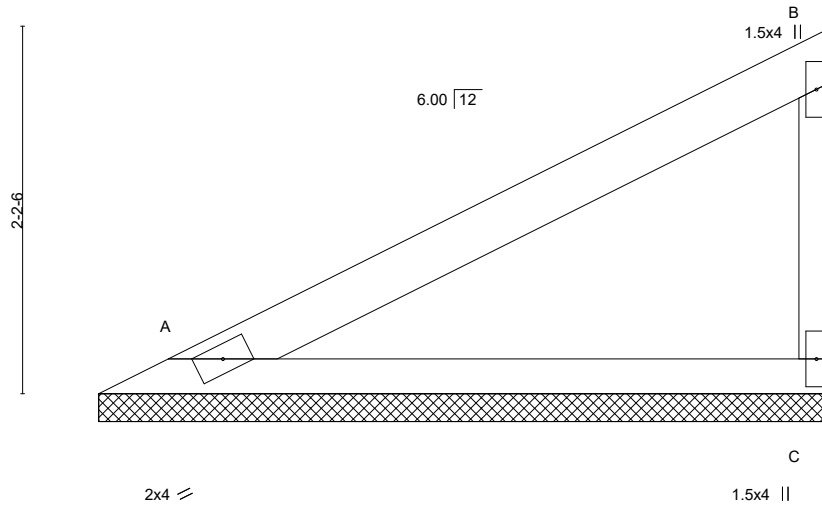

Scale = 1:13.8

LOADING (psf)	SPACING-	2-0-0	CSI.	DEFL.	in (loc)	l/defl	L/d	PLATES	GRIP
TCLL 25.0	Plate Grip DOL	1.15	TC 0.40	Vert(LL)	n/a	-	n/a	MT20	197/144
(Roof Snow=25.0)	Lumber DOL	1.15	BC 0.29	Vert(CT)	n/a	-	n/a		
TCDL 12.0	Rep Stress Incr	YES	WB 0.00	Horz(CT)	-0.00	C	n/a		
BCLL 0.0 *	Code IBC2018/TPI2014		Matrix-P					Weight: 10 lb	FT = 20%
BCDL 10.0									

LUMBER-

TOP CHORD 2x4 SPF No.2
BOT CHORD 2x3 SPF No.2
WEBS 2x3 SPF No.2

BRACING-

TOP CHORD Structural wood sheathing directly applied or 4-4-13 oc purlins, except end verticals.
BOT CHORD Rigid ceiling directly applied or 10-0-0 oc bracing.

REACTIONS.

(size) A=4-4-13, C=4-4-13
Max Horz A=58(LC 9)
Max Uplift A=-15(LC 10), C=-29(LC 10)
Max Grav A=239(LC 16), C=239(LC 16)

FORCES. (lb) - Max. Comp./Max. Ten. - All forces 250 (lb) or less except when shown.

NOTES-

- 1) Wind: ASCE 7-16; Vult=115mph (3-second gust) Vasd=91mph; TCDL=4.2psf; BCDL=5.0psf; h=30ft; Ke=1.00; Cat. II; Exp B; Enclosed; MWFRS (envelope) gable end zone; cantilever left and right exposed; end vertical left and right exposed; Lumber DOL=1.33 plate grip DOL=1.33
- 2) TCLL: ASCE 7-16; Pf=25.0 psf (Lum DOL = 1.15 Plate DOL = 1.15); Is=1.0; Rough Cat B; Partially Exp.; Ce=1.0; Cs=1.00; Ct=1.10
- 3) Unbalanced snow loads have been considered for this design.
- 4) Gable requires continuous bottom chord bearing.
- 5) This truss has been designed for a 10.0 psf bottom chord live load nonconcurrent with any other live loads.
- 6) * This truss has been designed for a live load of 20.0psf on the bottom chord in all areas where a rectangle 3-6-0 tall by 2-0-0 wide will fit between the bottom chord and any other members.
- 7) Provide mechanical connection (by others) of truss to bearing plate capable of withstanding 100 lb uplift at joint(s) A, C.
- 8) This truss is designed in accordance with the 2018 International Building Code section 2306.1 and referenced standard ANSI/TPI 1.



September 12, 2024

WARNING - Verify design parameters and READ NOTES ON THIS AND INCLUDED MITEK REFERENCE PAGE MII-7473 rev. 6/30/2020 BEFORE USE.

Design valid for use only with MiTek® connectors. This design is based only upon parameters shown, and is for an individual building component, not a truss system. Before use, the building designer must verify the applicability of design parameters and properly incorporate this design into the overall building design. Bracing indicated is to prevent buckling of individual truss web and/or chord members only. Additional temporary and permanent bracing is always required for stability and to prevent collapse with possible personal injury and property damage. For general guidance regarding the fabrication, storage, delivery, erection and bracing of trusses and truss systems, see

Safety Information available from Truss Plate Institute, 2670 Crain Highway, Suite 203 Waldorf, MD 20601

ANSI/TPI1 Quality Criteria, DSB-89 and BCSI Building Component



240 Stirling Crescent
Bradford, ON. L3Z 4L5

Job N0653A	Truss VU9	Truss Type Valley	Qty 20	Ply 1	Buildings A-H Job Reference (optional)	U1530895
---------------	--------------	----------------------	-----------	----------	---	----------

Alliance Truss (CA), Abbotsford, BC - V2S 7P6,

8.820 s Aug 30 2024 MiTek Industries, Inc. Thu Sep 12 02:48:38 2024 Page 1

ID:hFyjDMxrTsEK_kgkR0vWWVzF1gc-Cs43dmSJSmsxufHkTcYkIrL6RI86NwJFeebVS1yeVqd

3-0-0
3-0-0

Scale = 1:10.5

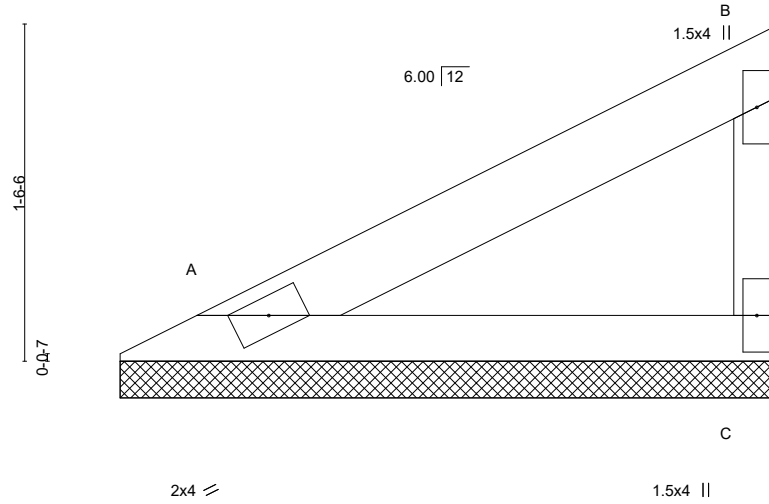

LOADING (psf)	SPACING-	CSI.	DEFL.	PLATES	GRIP
TCLL 25.0 (Roof Snow=25.0)	2-0-0 Plate Grip DOL 1.15 Lumber DOL 1.15	TC 0.15 BC 0.11 WB 0.00 Matrix-P	in (loc) l/defl L/d Vert(LL) n/a - n/a 999 Vert(CT) n/a - n/a 999 Horz(CT) -0.00 C n/a n/a	MT20	197/144
TCDL 12.0 BCLL 0.0 * BCDL 10.0	Rep Stress Incr YES Code IBC2018/TPI2014			Weight: 7 lb	FT = 20%

LUMBER-

TOP CHORD 2x4 SPF No.2
BOT CHORD 2x3 SPF No.2
WEBS 2x3 SPF No.2

BRACING-

TOP CHORD Structural wood sheathing directly applied or 3-0-13 oc purlins, except end verticals.
BOT CHORD Rigid ceiling directly applied or 10-0-0 oc bracing.

REACTIONS.

(size) A=3-0-0, C=3-0-0
Max Horz A=37(LC 7)
Max Uplift A=-10(LC 10), C=-19(LC 10)
Max Grav A=147(LC 16), C=147(LC 16)

FORCES. (lb) - Max. Comp./Max. Ten. - All forces 250 (lb) or less except when shown.

NOTES-

- 1) Wind: ASCE 7-16; Vult=115mph (3-second gust) Vasd=91mph; TCDL=4.2psf; BCDL=5.0psf; h=30ft; Ke=1.00; Cat. II; Exp B; Enclosed; MWFRS (envelope) gable end zone; cantilever left and right exposed; end vertical left and right exposed; Lumber DOL=1.33 plate grip DOL=1.33
- 2) TCLL: ASCE 7-16; Pf=25.0 psf (Lum DOL = 1.15 Plate DOL = 1.15); Is=1.0; Rough Cat B; Partially Exp.; Ce=1.0; Cs=1.00; Ct=1.10
- 3) Unbalanced snow loads have been considered for this design.
- 4) Gable requires continuous bottom chord bearing.
- 5) This truss has been designed for a 10.0 psf bottom chord live load nonconcurrent with any other live loads.
- 6) * This truss has been designed for a live load of 20.0psf on the bottom chord in all areas where a rectangle 3-6-0 tall by 2-0-0 wide will fit between the bottom chord and any other members.
- 7) Provide mechanical connection (by others) of truss to bearing plate capable of withstanding 100 lb uplift at joint(s) A, C.
- 8) This truss is designed in accordance with the 2018 International Building Code section 2306.1 and referenced standard ANSI/TPI 1.



September 12, 2024

WARNING - Verify design parameters and READ NOTES ON THIS AND INCLUDED MITEK REFERENCE PAGE MII-7473 rev. 6/30/2020 BEFORE USE.

Design valid for use only with MiTek® connectors. This design is based only upon parameters shown, and is for an individual building component, not a truss system. Before use, the building designer must verify the applicability of design parameters and properly incorporate this design into the overall building design. Bracing indicated is to prevent buckling of individual truss web and/or chord members only. Additional temporary and permanent bracing is always required for stability and to prevent collapse with possible personal injury and property damage. For general guidance regarding the fabrication, storage, delivery, erection and bracing of trusses and truss systems, see

Safety Information available from Truss Plate Institute, 2670 Crain Highway, Suite 203 Waldorf, MD 20601

ANSI/TPI1 Quality Criteria, DSB-89 and BCSI Building Component



240 Stirling Crescent
Bradford, ON. L3Z 4L5

Job	Truss	Truss Type	Qty	Ply	Buildings A-H	U1530810
N0653A	W1	GABLE	10	1		

Alliance Truss (CA), Abbotsford, BC - V2S 7P6,

8.630 s Jul 12 2024 MiTek Industries, Inc. Thu Sep 12 02:47:50 2024 Page 1

ID:hFyjDMxrTsEK_kgkR0vWWVzFfgc-RfC?PsB70Hq3NSgPqnL8w3ulTXbGKWrCDoi7J4zJC?f

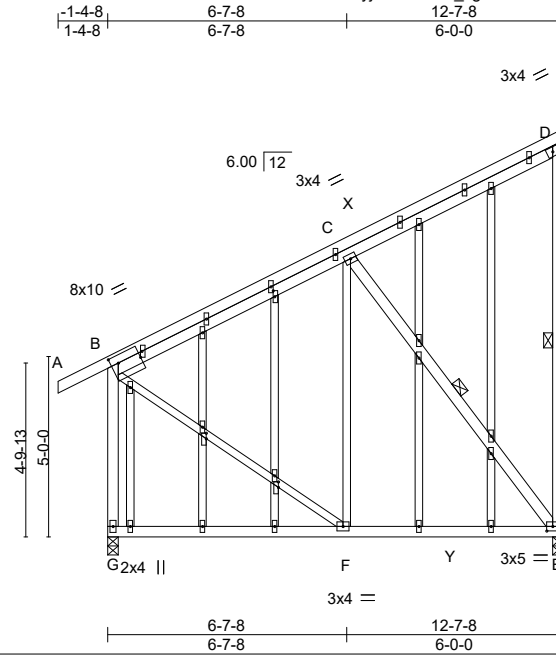

Scale: 3/16"=1'

Plate Offsets (X,Y)-- [B:0-2-0,0-0-7], [B:0-2-8,0-2-8], [E:0-2-0,0-1-8], [P:0-1-13,0-0-0], [Q:0-2-0,0-0-8], [S:0-1-13,0-0-0]

LOADING (psf)	SPACING-	CSI.	DEFL.	in (loc)	l/defl	L/d	PLATES	GRIP
TCLL 25.0 (Roof Snow=25.0)	2-0-0 Plate Grip DOL 1.15	TC 0.68	Vert(LL)	-0.05 E-F	>999	360	MT20	197/144
TCDL 12.0	Lumber DOL 1.15	BC 0.37	Vert(CT)	-0.09 F-G	>999	240		
BCLL 0.0 *	Rep Stress Incr YES	WB 0.24	Horz(CT)	-0.01 E	n/a	n/a		
BCDL 10.0	Code IBC2018/TPI2014	Matrix-MS	Wind(LL)	-0.04 E-F	>999	240	Weight: 115 lb	FT = 20%

LUMBER-

TOP CHORD 2x4 SPF No.2
 BOT CHORD 2x4 SPF No.2
 WEBS 2x4 SPF No.2 *Except*
 C-F,B-F: 2x3 SPF No.2
 OTHERS 2x3 SPF No.2

BRACING-

TOP CHORD Structural wood sheathing directly applied or 6-0-0 oc purlins, except end verticals.
 BOT CHORD Rigid ceiling directly applied or 6-0-0 oc bracing.
 WEBS 1 Row at midpt D-E, C-E

REACTIONS.

(size) G=0-3-8, E=0-3-8
 Max Horz G=323(LC 7)
 Max Uplift G=-60(LC 10), E=-141(LC 7)
 Max Grav G=754(LC 21), E=741(LC 3)

FORCES. (lb) - Max. Comp./Max. Ten. - All forces 250 (lb) or less except when shown.

TOP CHORD B-C=-469/36, D-E=-273/56, B-G=-689/88
 BOT CHORD F-G=-299/136, E-F=-140/347
 WEBS C-E=-544/134, B-F=-19/443

NOTES-

- 1) Wind: ASCE 7-16; Vult=115mph (3-second gust) Vasd=91mph; TCDL=4.2psf; BCDL=5.0psf; h=30ft; Ke=1.00; Cat. II; Exp B; Enclosed; MWFRS (envelope) gable end zone; cantilever left and right exposed ; end vertical left and right exposed; Lumber DOL=1.33 plate grip DOL=1.33
- 2) Truss designed for wind loads in the plane of the truss only. For studs exposed to wind (normal to the face), see Standard Industry Gable End Details as applicable, or consult qualified building designer as per ANSI/TPI 1.
- 3) TCLL: ASCE 7-16; Pf=25.0 psf (Lum DOL=1.15 Plate DOL=1.15); Is=1.0; Rough Cat B; Partially Exp.; Ce=1.0; Cs=1.00; Ct=1.10
- 4) Unbalanced snow loads have been considered for this design.
- 5) This truss has been designed for greater of min roof live load of 18.0 psf or 2.00 times flat roof load of 25.0 psf on overhangs non-concurrent with other live loads.
- 6) All plates are 1.5x4 MT20 unless otherwise indicated.
- 7) Gable studs spaced at 2-0-0 oc.
- 8) This truss has been designed for a 10.0 psf bottom chord live load nonconcurrent with any other live loads.
- 9) * This truss has been designed for a live load of 20.0psf on the bottom chord in all areas where a rectangle 3-6-0 tall by 2-0-0 wide will fit between the bottom chord and any other members, with BCDL = 10.0psf.
- 10) Provide mechanical connection (by others) of truss to bearing plate capable of withstanding 100 lb uplift at joint(s) G except (jt=lb) E=141.
- 11) This truss is designed in accordance with the 2018 International Building Code section 2306.1 and referenced standard ANSI/TPI 1.
- 12) No notches allowed in overhang and 10408 from left end and 0 from right end or 12" along rake from scarf, whichever is larger. Minimum 1.5x4 tie plates required at 2-0-0 o.c. maximum between the stacking chords. For edge-wise notching, provide at least one tie plate between each notch.



September 12, 2024

WARNING - Verify design parameters and READ NOTES ON THIS AND INCLUDED MITEK REFERENCE PAGE MII-7473 rev. 6/30/2020 BEFORE USE.

Design valid for use only with MiTek® connectors. This design is based only upon parameters shown, and is for an individual building component, not a truss system. Before use, the building designer must verify the applicability of design parameters and properly incorporate this design into the overall building design. Bracing indicated is to prevent buckling of individual truss web and/or chord members only. Additional temporary and permanent bracing is always required for stability and to prevent collapse with possible personal injury and property damage. For general guidance regarding the fabrication, storage, delivery, erection and bracing of trusses and truss systems, see

ANSI/TPI1 Quality Criteria, DSB-89 and BCSI Building Component

Safety Information available from Truss Plate Institute, 2670 Crain Highway, Suite 203 Waldorf, MD 20601



240 Stirling Crescent
 Bradford, ON. L3Z 4L5

Job	Truss	Truss Type	Qty	Ply	Buildings A-H	U1530811
N0653A	W2	Monopitch	20	1		

Alliance Truss (CA), Abbotsford, BC - V2S 7P6,

8.630 s Jul 12 2024 MiTek Industries, Inc. Thu Sep 12 02:47:51 2024 Page 1

Job Reference (optional)

ID:hFyjDMxrTsEK_kgkR0vWWVzFfgc-RfC?PsB70Hq3NSgPqnL8w3ulTXbGKWrCDoi7J4zJC?f

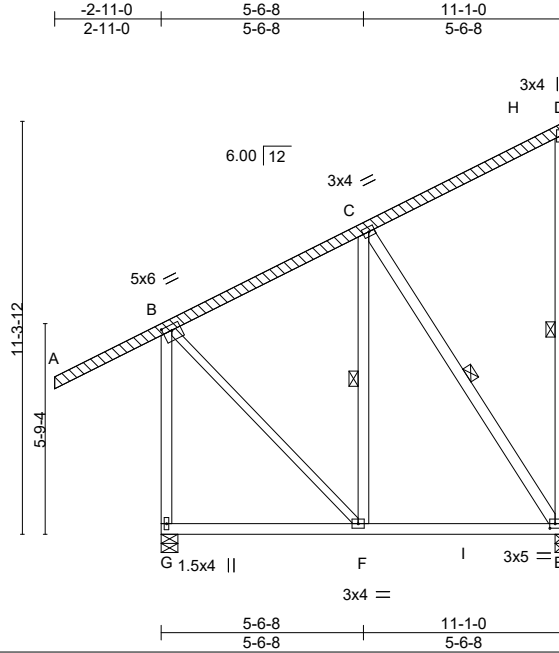

Scale = 1:63.1

Plate Offsets (X,Y)-- [B:0-3-0,0-1-12], [D:Edge,0-1-12], [E:0-1-12,0-1-8]

LOADING (psf)	SPACING-	CSI.	DEFL.	in (loc)	l/defl	L/d	PLATES	GRIP
TCLL 25.0 (Roof Snow=25.0)	2-0-0 Plate Grip DOL 1.15	TC 0.63	Vert(LL)	-0.04	E-F	>999	MT20	197/144
TCDL 12.0	Lumber DOL 1.15	BC 0.29	Vert(CT)	-0.06	E-F	>999		
BCLL 0.0 *	Rep Stress Incr YES	WB 0.18	Horz(CT)	-0.00	E	n/a		n/a
BCDL 10.0	Code IBC2018/TPI2014	Matrix-MS	Wind(LL)	-0.03	E-F	>999		240
							Weight: 93 lb	FT = 20%

LUMBER-

TOP CHORD 2x4 SPF No.2
 BOT CHORD 2x4 SPF No.2
 WEBS 2x4 SPF No.2 *Except*
 B-F: 2x3 SPF No.2
 OTHERS 2x4 SPF No.2
 LBR SCAB A-D 2x4 SPF No.2 one side

BRACING-

TOP CHORD Structural wood sheathing directly applied or 6-0-0 oc purlins, except end verticals.
 BOT CHORD Rigid ceiling directly applied or 6-0-0 oc bracing.
 WEBS 1 Row at midpt D-E, C-F, C-E

REACTIONS.

(size) G=0-5-8, E=0-3-8
 Max Horz G=345(LC 7)
 Max Uplift G=-79(LC 10), E=-175(LC 7)
 Max Grav G=817(LC 17), E=637(LC 3)

FORCES. (lb) - Max. Comp./Max. Ten. - All forces 250 (lb) or less except when shown.

TOP CHORD B-C=-356/37, D-E=-261/53, B-G=-774/103
 BOT CHORD F-G=-322/137, E-F=-153/251
 WEBS C-E=-408/155, B-F=-19/412

NOTES-

- Attached 15-9-9 scab A to D, front face(s) 2x4 SPF No.2 with 1 row(s) of 10d (0.131"x3") nails spaced 9" o.c.except : starting at 2-5-1 from end at joint A, nail 1 row(s) at 4" o.c. for 2-0-0; starting at 8-5-8 from end at joint A, nail 1 row(s) at 7" o.c. for 2-0-0; starting at 13-5-14 from end at joint A, nail 1 row(s) at 7" o.c. for 2-0-0.
- Wind: ASCE 7-16; Vult=115mph (3-second gust) Vasd=91mph; TC DL=4.2psf; BCDL=5.0psf; h=30ft; Ke=1.00; Cat. II; Exp B; Enclosed; MWFRS (envelope) gable end zone; cantilever left and right exposed ; end vertical left and right exposed; Lumber DOL=1.33 plate grip DOL=1.33
- TCLL: ASCE 7-16; Pf=25.0 psf (Lum DOL=1.15 Plate DOL=1.15); Is=1.0; Rough Cat B; Partially Exp.; Ce=1.0; Cs=1.0; Ct=1.10
- Unbalanced snow loads have been considered for this design.
- This truss has been designed for greater of min roof live load of 18.0 psf or 2.00 times flat roof load of 25.0 psf on overhangs non-concurrent with other live loads.
- This truss has been designed for a 10.0 psf bottom chord live load nonconcurrent with any other live loads.
- * This truss has been designed for a live load of 20.0psf on the bottom chord in all areas where a rectangle 3-6-0 tall by 2-0-0 wide will fit between the bottom chord and any other members, with BCDL = 10.0psf.
- Provide mechanical connection (by others) of truss to bearing plate capable of withstanding 100 lb uplift at joint(s) G except (jt=lb) E=175.
- This truss is designed in accordance with the 2018 International Building Code section 2306.1 and referenced standard ANSI/TPI 1.



September 12, 2024

WARNING - Verify design parameters and READ NOTES ON THIS AND INCLUDED MITEK REFERENCE PAGE MII-7473 rev. 6/30/2020 BEFORE USE.

Design valid for use only with MiTek® connectors. This design is based only upon parameters shown, and is for an individual building component, not a truss system. Before use, the building designer must verify the applicability of design parameters and properly incorporate this design into the overall building design. Bracing indicated is to prevent buckling of individual truss web and/or chord members only. Additional temporary and permanent bracing is always required for stability and to prevent collapse with possible personal injury and property damage. For general guidance regarding the fabrication, storage, delivery, erection and bracing of trusses and truss systems, see

Safety Information available from Truss Plate Institute, 2670 Crain Highway, Suite 203 Waldorf, MD 20601

ANSI/TPI1 Quality Criteria, DSB-89 and BCSI Building Component



240 Stirling Crescent
 Bradford, ON. L3Z 4L5

Job N0653A	Truss X1	Truss Type GABLE	Qty 8	Ply 1	Buildings A-H Job Reference (optional)	U1530812
---------------	-------------	---------------------	----------	----------	---	----------

Alliance Truss (CA), Abbotsford, BC - V2S 7P6, 8.630 s Jul 12 2024 MiTek Industries, Inc. Thu Sep 12 02:47:52 2024 Page 1

ID:hFyjDMxrTsEK_kgkR0vWWVzFgC-RfC?PsB70Hq3NSgPqnL8w3ulTXbGKWrCDoi7J4zJC7f

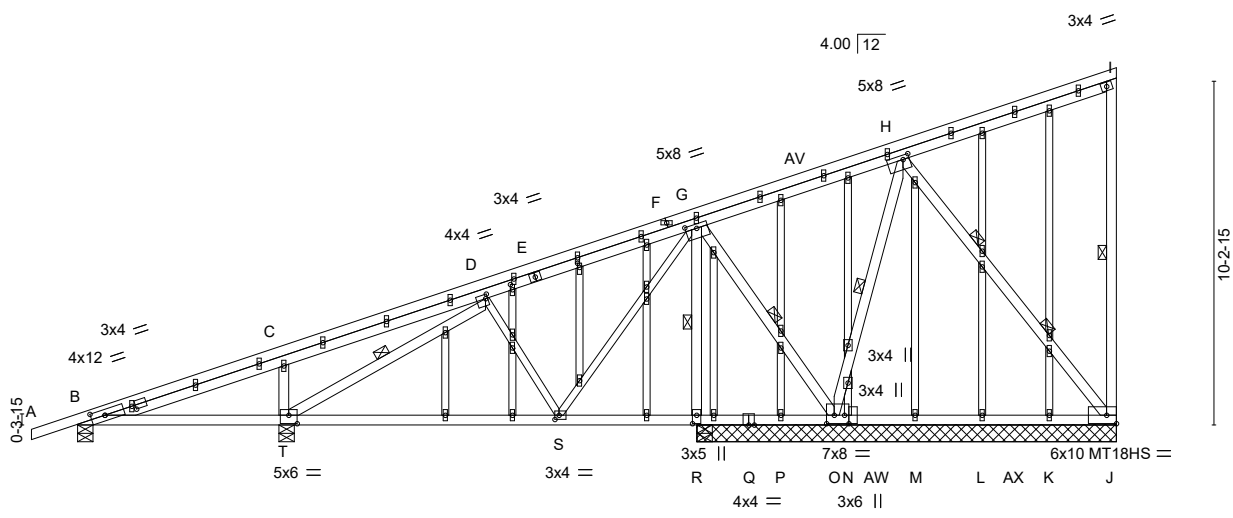
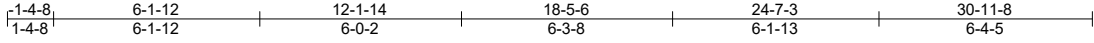

Scale = 1:68.7

Plate Offsets (X,Y)--	[B:0-5-0,0-2-0], [B:0-11-7,0-1-8], [D:0-0-12,0-1-8], [G:0-4-0,0-1-8], [H:0-2-4,0-1-8], [N:0-3-0,0-1-9], [O:0-2-12,0-3-0], [R:0-3-0,0-1-8], [S:0-1-8,0-1-8], [T:0-3-0,0-3-0], [AM:0-1-7,0-0-12], [AO:0-1-14,0-0-12]
-----------------------	--

LOADING (psf)	SPACING-	CSI.	DEFL.	in (loc)	l/defl	L/d	PLATES	GRIP
TCLL 25.0 (Roof Snow=25.0)	2-0-0	TC 0.81	Vert(LL) -0.10	S-T	>999	360	MT20	197/144
TCDL 12.0	Plate Grip DOL 1.15	BC 0.85	Vert(CT) -0.19	S-T	>793	240	MT18HS	197/144
BCLL 0.0 *	Lumber DOL 1.15	WB 0.98	Horz(CT) -0.11	K	n/a	n/a		
BCDL 10.0	Rep Stress Incr YES	Matrix-MS	Wind(LL) 0.07	T-AU	>999	240		
	Code IBC2018/TPI2014						Weight: 221 lb	FT = 20%

LUMBER-	BRACING-
TOP CHORD 2x4 SPF No.2	TOP CHORD Structural wood sheathing directly applied or 3-10-7 oc purlins, except end verticals.
BOT CHORD 2x4 SPF No.2	BOT CHORD Rigid ceiling directly applied or 2-10-8 oc bracing.
WEBS 2x4 SPF No.2 *Except*	WEBS 1 Row at midpt I-J, D-T, G-O, H-O, G-R
D-S,G-S: 2x3 SPF No.2	2 Rows at 1/3 pts H-J
OTHERS 2x3 SPF No.2	

REACTIONS. All bearings 12-6-0 except (jt=length) B=0-5-8, T=0-5-8.
 (lb) - Max Horz B=695(LC 35)
 Max Uplift All uplift 100 lb or less at joint(s) K except J=2155(LC 35), B=586(LC 32), T=1144(LC 40), O=921(LC 40), R=2317(LC 40)
 Max Grav All reactions 250 lb or less at joint(s) K, L, M, N, P except J=2110(LC 52), B=797(LC 29), T=1707(LC 29), O=1235(LC 29), R=2529(LC 53), R=700(LC 1)

FORCES. (lb) - Max. Comp./Max. Ten. - All forces 250 (lb) or less except when shown.
 TOP CHORD B-C=-1550/1315, C-D=-1718/1614, D-G=-1364/1148, G-H=-939/899, H-I=-1746/1646, I-J=-309/54
 BOT CHORD B-T=-1524/1369, S-T=-3197/3234, R-S=-3728/3621, P-R=-3669/3594, O-P=-2209/2069, N-O=-3404/3316, M-N=-3160/3072, L-M=-1972/1883, K-L=-755/695, J-K=-1755/1667
 WEBS C-T=-462/160, D-T=-2219/2062, D-S=-634/643, G-S=-591/956, G-O=-2560/2584, H-O=-3058/2973, H-J=-2599/2671, G-R=-2457/2311

- NOTES-**
- 1) Wind: ASCE 7-16; Vult=115mph (3-second gust) Vasd=91mph; TC DL=4.2psf; BCDL=5.0psf; h=30ft; Ke=1.00; Cat. II; Exp B; Enclosed; MWFRS (envelope) gable end zone; cantilever left and right exposed; end vertical left and right exposed; Lumber DOL=1.33 plate grip DOL=1.33
 - 2) Truss designed for wind loads in the plane of the truss only. For studs exposed to wind (normal to the face), see Standard Industry Gable End Details as applicable, or consult qualified building designer as per ANSI/TPI 1.
 - 3) TCLL: ASCE 7-16; Pf=25.0 psf (Lum DOL=1.15 Plate DOL=1.15); Is=1.0; Rough Cat B; Partially Exp.; Ce=1.0; Cs=1.00; Ct=1.10
 - 4) Unbalanced snow loads have been considered for this design.
 - 5) This truss has been designed for greater of min roof live load of 20.0 psf or 2.00 times flat roof load of 25.0 psf on overhangs non-concurrent with other live loads.
 - 6) All plates are MT20 plates unless otherwise indicated.
 - 7) All plates are 1.5x4 MT20 unless otherwise indicated.
 - 8) Gable studs spaced at 2-0-0 oc.
 - 9) This truss has been designed for a 10.0 psf bottom chord live load nonconcurrent with any other live loads.
 - 10) * This truss has been designed for a live load of 20.0psf on the bottom chord in all areas where a rectangle 3-6-0 tall by 2-0-0 wide will fit between the bottom chord and any other members, with BCDL = 10.0psf.
 - 11) Provide mechanical connection (by others) of truss to bearing plate capable of withstanding 100 lb uplift at joint(s) K except (jt=lb) J=2155, B=586, T=1144, O=921, R=2317.



September 12, 2024

Job	Truss	Truss Type	Qty	Ply	Buildings A-H	U1530812
N0653A	X1	GABLE	8	1	Job Reference (optional)	

Alliance Truss (CA), Abbotsford, BC - V2S 7P6,

8.630 s Jul 12 2024 MiTek Industries, Inc. Thu Sep 12 02:47:52 2024 Page 2
 ID:hFyjDMxrTsEK_kgkR0vWWVzFgc-RfC?PsB70Hq3NSgPqnL8w3ulTXbGKWrCDoi7J4zJC?f

- NOTES-**
- 12) This truss is designed in accordance with the 2018 International Building Code section 2306.1 and referenced standard ANSI/TPI 1.
 - 13) This truss has been designed for a total drag load of 240 plf. Lumber DOL=(1.33) Plate grip DOL=(1.33) Connect truss to resist drag loads along bottom chord from 18-5-8 to 30-11-8 for 594.4 plf.
 - 14) No notches allowed in overhang and 10408 from left end and 0 from right end or 12" along rake from scarf, whichever is larger. Minimum 1.5x4 tie plates required at 2-0-0 o.c. maximum between the stacking chords. For edge-wise notching, provide at least one tie plate between each notch.

WARNING - Verify design parameters and READ NOTES ON THIS AND INCLUDED MITEK REFERANCE PAGE MII-7473 rev. 6/30/2020 BEFORE USE.

Design valid for use only with MiTek® connectors. This design is based only upon parameters shown, and is for an individual building component, not a truss system. Before use, the building designer must verify the applicability of design parameters and properly incorporate this design into the overall building design. Bracing indicated is to prevent buckling of individual truss web and/or chord members only. Additional temporary and permanent bracing is always required for stability and to prevent collapse with possible personal injury and property damage. For general guidance regarding the fabrication, storage, delivery, erection and bracing of trusses and truss systems, see

Safety Information available from Truss Plate Institute, 2670 Crain Highway, Suite 203 Waldorf, MD 20601

ANSI/TPI1 Quality Criteria, DSB-89 and BCSI Building Component



240 Stirling Crescent
 Bradford, ON. L3Z 4L5

Job	Truss	Truss Type	Qty	Ply	Buildings A-H	U1530813
N0653A	X2	Monopitch	32	1		

Alliance Truss (CA), Abbotsford, BC - V2S 7P6, 8.630 s Jul 12 2024 MiTek Industries, Inc. Thu Sep 12 02:47:53 2024 Page 1

ID:hFyjDMxrTsEK_kgkR0vWWVzFfgc-RfC?PsB70Hq3NSgPqnL8w3ulTXbGKWrCDoi7J4zJC?f

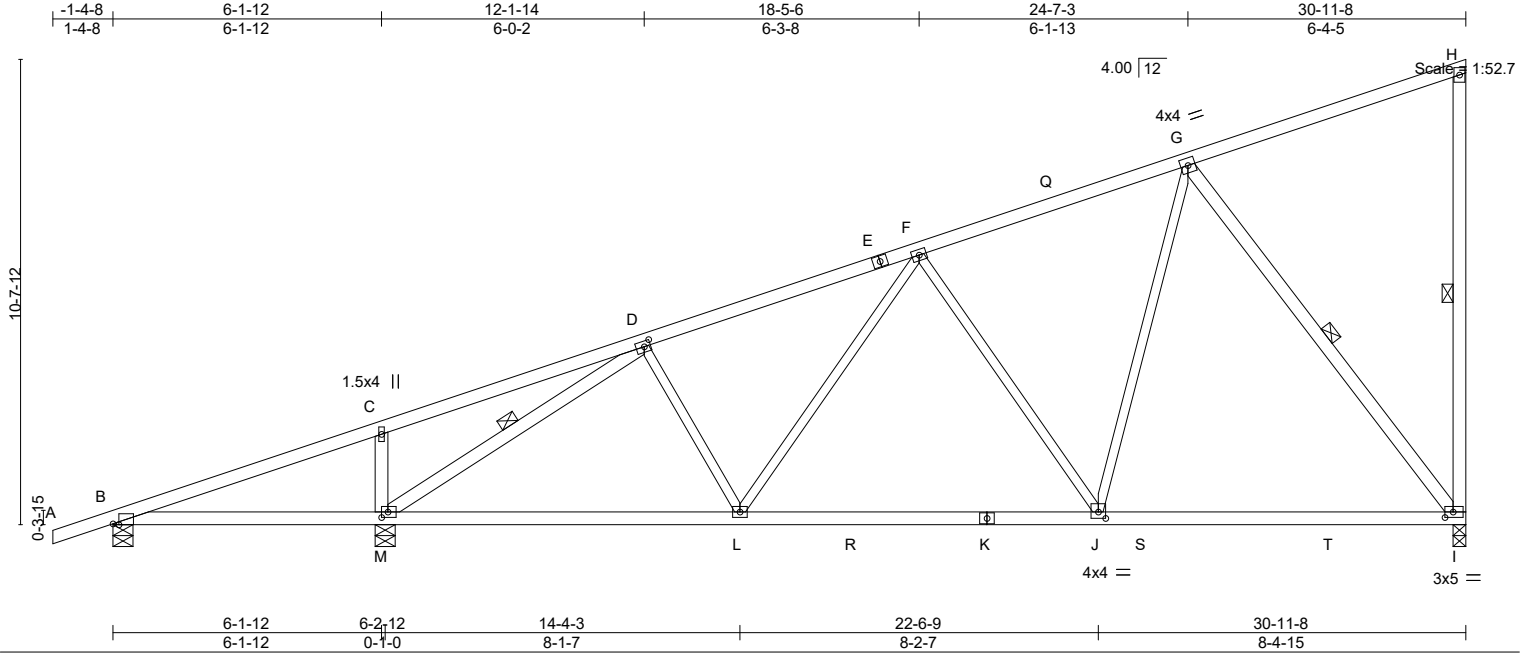

Plate Offsets (X,Y)-- [B:0-1-10,Edge], [D:0-1-12,0-1-8], [I:0-2-4,0-1-8], [J:0-2-0,0-1-12], [M:0-1-12,0-1-8]

LOADING (psf)	SPACING-	CSI.	DEFL.	PLATES	GRIP
TCLL 25.0 (Roof Snow=25.0)	2-0-0 Plate Grip DOL 1.15	TC 0.78	in (loc) l/defl L/d	MT20	197/144
TCDL 12.0	Lumber DOL 1.15	BC 0.84	Vert(LL) -0.22 I-J >999 360		
BCLL 0.0 *	Rep Stress Incr YES	WB 0.76	Vert(CT) -0.35 I-J >842 240		
BCDL 10.0	Code IBC2018/TPI2014	Matrix-MS	Horz(CT) 0.05 I n/a n/a		
			Wind(LL) -0.06 I-J >999 240	Weight: 129 lb	FT = 20%

LUMBER-	BRACING-
TOP CHORD 2x4 SPF No.2	TOP CHORD Structural wood sheathing directly applied or 4-4-1 oc purlins, except end verticals.
BOT CHORD 2x4 SPF No.2	BOT CHORD Rigid ceiling directly applied or 10-0-0 oc bracing, Except:
WEBS 2x4 SPF No.2 *Except* D-L,F-L,F-J,G-J: 2x3 SPF No.2	WEBS 1 Row at midpt H-I, D-M, G-I

REACTIONS. (size) I=0-3-8, B=0-5-8, M=0-5-8
 Max Horz B=347(LC 9)
 Max Uplift I=-169(LC 10), B=-48(LC 6), M=-195(LC 10)
 Max Grav I=1468(LC 3), B=291(LC 1), M=1728(LC 3)

FORCES. (lb) - Max. Comp./Max. Ten. - All forces 250 (lb) or less except when shown.
 TOP CHORD D-F=-1555/160, F-G=-1151/138, H-I=-301/52
 BOT CHORD B-M=-285/0, L-M=-188/1346, J-L=-147/1312, I-J=-112/834
 WEBS C-M=-473/153, D-M=-1830/189, F-J=-549/154, G-J=-51/847, G-I=-1360/201

- NOTES-**
- 1) Wind: ASCE 7-16; Vult=115mph (3-second gust) Vasd=91mph; TCDL=4.2psf; BCDL=5.0psf; h=30ft; Ke=1.00; Cat. II; Exp B; Enclosed; MWFRS (envelope) gable end zone; cantilever left and right exposed; end vertical left and right exposed; Lumber DOL=1.33 plate grip DOL=1.33
 - 2) TCLL: ASCE 7-16; Pf=25.0 psf (Lum DOL=1.15 Plate DOL=1.15); Is=1.0; Rough Cat B; Partially Exp.; Ce=1.0; Cs=1.0; Ct=1.10
 - 3) Unbalanced snow loads have been considered for this design.
 - 4) This truss has been designed for greater of min roof live load of 20.0 psf or 2.00 times flat roof load of 25.0 psf on overhangs non-concurrent with other live loads.
 - 5) All plates are 3x4 MT20 unless otherwise indicated.
 - 6) This truss has been designed for a 10.0 psf bottom chord live load nonconcurrent with any other live loads.
 - 7) * This truss has been designed for a live load of 20.0psf on the bottom chord in all areas where a rectangle 3-6-0 tall by 2-0-0 wide will fit between the bottom chord and any other members, with BCDL = 10.0psf.
 - 8) Provide mechanical connection (by others) of truss to bearing plate capable of withstanding 100 lb uplift at joint(s) B except (jt=Ib) I=169, M=195.
 - 9) This truss is designed in accordance with the 2018 International Building Code section 2306.1 and referenced standard ANSI/TPI 1.



September 12, 2024

WARNING - Verify design parameters and READ NOTES ON THIS AND INCLUDED MITEK REFERENCE PAGE MII-7473 rev. 6/30/2020 BEFORE USE.

Design valid for use only with MiTek® connectors. This design is based only upon parameters shown, and is for an individual building component, not a truss system. Before use, the building designer must verify the applicability of design parameters and properly incorporate this design into the overall building design. Bracing indicated is to prevent buckling of individual truss web and/or chord members only. Additional temporary and permanent bracing is always required for stability and to prevent collapse with possible personal injury and property damage. For general guidance regarding the fabrication, storage, delivery, erection and bracing of trusses and truss systems, see **ANSI/TPI1 Quality Criteria, DSB-89 and BCSI Building Component Safety Information** available from Truss Plate Institute, 2670 Crain Highway, Suite 203 Waldorf, MD 20601



240 Stirling Crescent
Bradford, ON. L3Z 4L5

Job	Truss	Truss Type	Qty	Ply	Buildings A-H	U1530896
N0653A	X3	Roof Special	8	1		

Alliance Truss (CA), Abbotsford, BC - V2S 7P6, 8.820 s Aug 30 2024 MiTek Industries, Inc. Thu Sep 12 02:48:39 2024 Page 1

ID:hFyjDMxrTsEK_kgkR0vWWVzFlgc-g3eRq6TxD3_oVosw1J3zq2t4x9Gj6CjPtIK2_TyeVqc

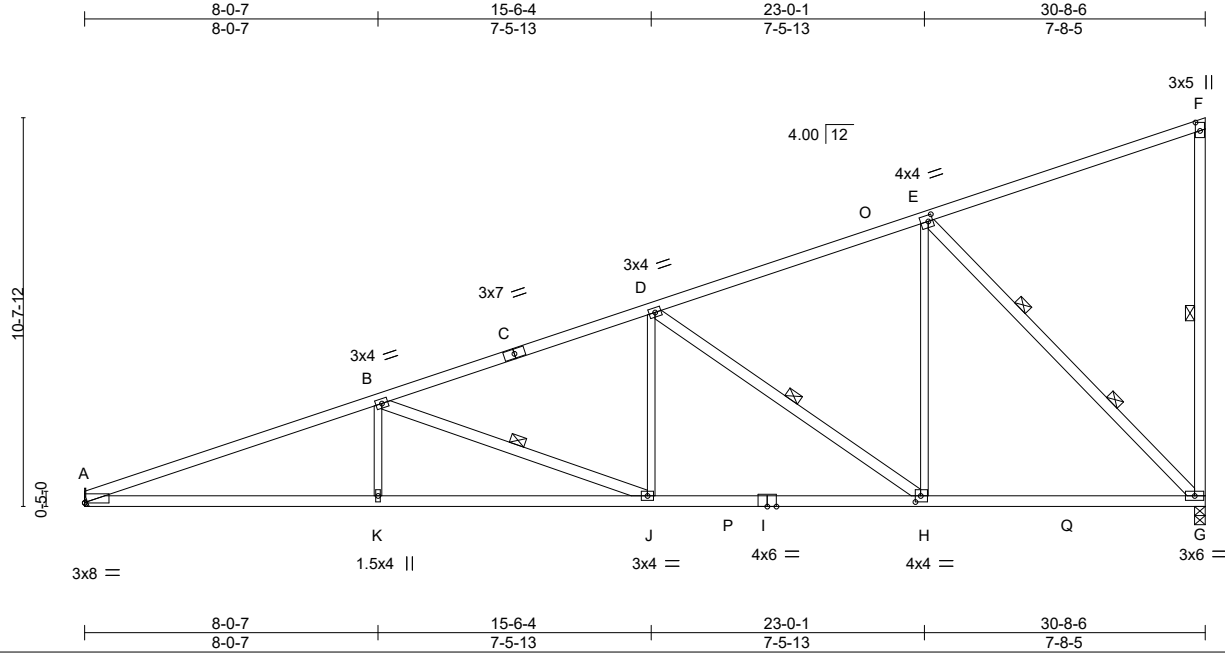

Plate Offsets (X,Y)-- [A:0-0-0,0-0-2], [E:0-1-8,0-2-0], [F:0-2-12,0-1-8], [H:0-1-12,0-2-0]

LOADING (psf)	SPACING-	CSI.	DEFL.	in (loc)	l/defl	L/d	PLATES	GRIP
TCLL 25.0 (Roof Snow=25.0)	2-0-0 Plate Grip DOL 1.15	TC 0.99	Vert(LL)	-0.22	J-K	>999	MT20	197/144
TCDL 12.0	Lumber DOL 1.15	BC 0.92	Vert(CT)	-0.40	J-K	>924		
BCLL 0.0 *	Rep Stress Incr YES	WB 0.76	Horz(CT)	0.11	G	n/a		
BCDL 10.0	Code IBC2018/TPI2014	Matrix-MS	Wind(LL)	0.10	K-N	>999	Weight: 127 lb	FT = 20%

LUMBER-

TOP CHORD 2x4 SPF 2100F 1.8E *Except*
A-C: 2x4 SPF No.2
BOT CHORD 2x4 SPF 2100F 1.8E *Except*
G-I: 2x4 SPF No.2
WEBS 2x4 SPF No.2 *Except*
B-K,D-J,E-H: 2x3 SPF No.2

BRACING-

TOP CHORD Structural wood sheathing directly applied, except end verticals.
BOT CHORD Rigid ceiling directly applied or 10-0-0 oc bracing, Except:
2-2-0 oc bracing: H-J.
WEBS 1 Row at midpt F-G, B-J, D-H
2 Rows at 1/3 pts E-G

REACTIONS.

(size) G=0-3-8, A=Mechanical
Max Horz A=338(LC 9)
Max Uplift G=-207(LC 10), A=-156(LC 6)
Max Grav G=1753(LC 3), A=1524(LC 3)

FORCES. (lb) - Max. Comp./Max. Ten. - All forces 250 (lb) or less except when shown.

TOP CHORD A-B=-3682/372, B-D=-2548/265, D-E=-1444/167, F-G=-367/63
BOT CHORD A-K=-451/3429, J-K=-451/3429, H-J=-273/2347, G-H=-118/1309
WEBS B-K=0/317, B-J=-1155/190, D-J=0/652, D-H=-1291/206, E-H=-48/1084, E-G=-1856/257

NOTES-

- 1) Wind: ASCE 7-16; Vult=115mph (3-second gust) Vasd=91mph; TCDL=4.2psf; BCDL=5.0psf; h=30ft; Ke=1.00; Cat. II; Exp B; Enclosed; MWFRS (envelope) gable end zone; cantilever left and right exposed; end vertical left and right exposed; Lumber DOL=1.33 plate grip DOL=1.33
- 2) TCLL: ASCE 7-16; Pf=25.0 psf (Lum DOL = 1.15 Plate DOL = 1.15); Is=1.0; Rough Cat B; Partially Exp.; Ce=1.0; Cs=1.00; Ct=1.10
- 3) Unbalanced snow loads have been considered for this design.
- 4) This truss has been designed for a 10.0 psf bottom chord live load nonconcurrent with any other live loads.
- 5) * This truss has been designed for a live load of 20.0psf on the bottom chord in all areas where a rectangle 3-6-0 tall by 2-0-0 wide will fit between the bottom chord and any other members, with BCDL = 10.0psf.
- 6) Refer to girder(s) for truss to truss connections.
- 7) Provide mechanical connection (by others) of truss to bearing plate capable of withstanding 100 lb uplift at joint(s) except (jt=lb) G=207, A=156.
- 8) This truss is designed in accordance with the 2018 International Building Code section 2306.1 and referenced standard ANSI/TPI 1.



September 12, 2024

WARNING - Verify design parameters and READ NOTES ON THIS AND INCLUDED MITEK REFERENCE PAGE MII-7473 rev. 6/30/2020 BEFORE USE.

Design valid for use only with MiTek® connectors. This design is based only upon parameters shown, and is for an individual building component, not a truss system. Before use, the building designer must verify the applicability of design parameters and properly incorporate this design into the overall building design. Bracing indicated is to prevent buckling of individual truss web and/or chord members only. Additional temporary and permanent bracing is always required for stability and to prevent collapse with possible personal injury and property damage. For general guidance regarding the fabrication, storage, delivery, erection and bracing of trusses and truss systems, see **ANSI/TPI1 Quality Criteria, DSB-89 and BCSI Building Component Safety Information** available from Truss Plate Institute, 2670 Crain Highway, Suite 203 Waldorf, MD 20601



Job	Truss	Truss Type	Qty	Ply	Buildings A-H	U1530897
N0653A	X3A	Roof Special	48	1		

Alliance Truss (CA), Abbotsford, BC - V2S 7P6, 8.820 s Aug 30 2024 MiTek Industries, Inc. Thu Sep 12 02:48:39 2024 Page 1
 ID:hFyjDMxrTsEK_kgkR0vWVvzFlgc-g3eRq6TxD3_oVosw1J3zq2t8f9H669FPtIK2_TyeVqc

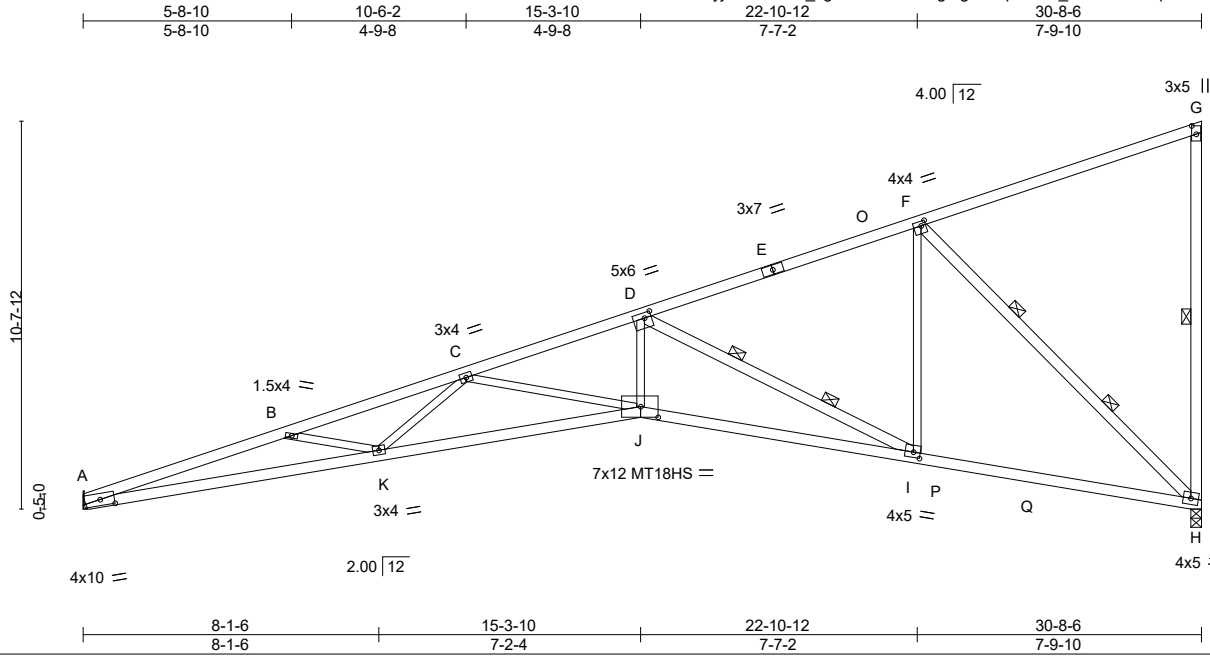

Plate Offsets (X,Y)-- [A:0-4-11,0-2-0], [D:0-2-4,0-1-12], [F:0-1-8,0-1-8], [G:0-2-12,0-1-8], [I:0-2-4,0-1-12], [J:0-5-12,0-3-8]

LOADING (psf)	SPACING-	CSI.	DEFL.	PLATES	GRIP
TCLL 25.0 (Roof Snow=25.0)	2-0-0 Plate Grip DOL 1.15 Lumber DOL 1.15	TC 0.76 BC 0.83 WB 0.92 Matrix-MS	in (loc) l/defl L/d Vert(LL) -0.65 J-K >568 360 Vert(CT) -1.16 J-K >317 240 Horz(CT) 0.50 H n/a n/a Wind(LL) 0.34 J-K >999 240	MT20 MT18HS Weight: 121 lb	197/144 197/144 FT = 20%

LUMBER-

TOP CHORD 2x4 SPF 2100F 1.8E
 BOT CHORD 2x4 SPF 2100F 1.8E
 WEBS 2x3 SPF No.2 *Except*
 G-H,D-I,F-H: 2x4 SPF No.2

BRACING-

TOP CHORD Structural wood sheathing directly applied or 2-2-8 oc purlins, except end verticals.
 BOT CHORD Rigid ceiling directly applied or 8-2-13 oc bracing.
 WEBS 1 Row at midpt G-H
 2 Rows at 1/3 pts D-I, F-H

REACTIONS.

(size) H=0-3-8, A=Mechanical
 Max Horz A=339(LC 9)
 Max Uplift H=-208(LC 10), A=-156(LC 6)
 Max Grav H=1745(LC 16), A=1521(LC 3)

FORCES. (lb) - Max. Comp./Max. Ten. - All forces 250 (lb) or less except when shown.

TOP CHORD A-B=-6667/817, B-C=-6340/677, C-D=-4792/541, D-F=-1721/188, G-H=-367/63
 BOT CHORD A-K=-905/6352, J-K=-748/5680, I-J=-549/4582, H-I=-147/1630
 WEBS B-K=-389/180, C-K=0/586, C-J=-1107/201, D-J=-191/2169, D-I=-3298/458, F-I=-67/1380,
 F-H=-2226/290

NOTES-

- 1) Wind: ASCE 7-16; Vult=115mph (3-second gust) Vasd=91mph; TCDL=4.2psf; BCDL=5.0psf; h=30ft; Ke=1.00; Cat. II; Exp B; Enclosed; MWFRS (envelope) gable end zone; cantilever left and right exposed ; end vertical left and right exposed; Lumber DOL=1.33 plate grip DOL=1.33
- 2) TCLL: ASCE 7-16; Pf=25.0 psf (Lum DOL = 1.15 Plate DOL = 1.15); Is=1.0; Rough Cat B; Partially Exp.; Ce=1.0; Cs=1.00; Ct=1.10
- 3) Unbalanced snow loads have been considered for this design.
- 4) All plates are MT20 plates unless otherwise indicated.
- 5) This truss has been designed for a 10.0 psf bottom chord live load nonconcurrent with any other live loads.
- 6) * This truss has been designed for a live load of 20.0psf on the bottom chord in all areas where a rectangle 3-6-0 tall by 2-0-0 wide will fit between the bottom chord and any other members, with BCDL = 10.0psf.
- 7) Refer to girder(s) for truss to truss connections.
- 8) Bearing at joint(s) H considers parallel to grain value using ANSI/TPI 1 angle to grain formula. Building designer should verify capacity of bearing surface.
- 9) Provide mechanical connection (by others) of truss to bearing plate capable of withstanding 100 lb uplift at joint(s) except (jt=lb) H=208, A=156.
- 10) This truss is designed in accordance with the 2018 International Building Code section 2306.1 and referenced standard ANSI/TPI 1.



September 12, 2024

WARNING - Verify design parameters and READ NOTES ON THIS AND INCLUDED MITEK REFERENCE PAGE MII-7473 rev. 6/30/2020 BEFORE USE.

Design valid for use only with MiTek® connectors. This design is based only upon parameters shown, and is for an individual building component, not a truss system. Before use, the building designer must verify the applicability of design parameters and properly incorporate this design into the overall building design. Bracing indicated is to prevent buckling of individual truss web and/or chord members only. Additional temporary and permanent bracing is always required for stability and to prevent collapse with possible personal injury and property damage. For general guidance regarding the fabrication, storage, delivery, erection and bracing of trusses and truss systems, see

ANSI/TPI1 Quality Criteria, DSB-89 and BCSI Building Component Safety Information available from Truss Plate Institute, 2670 Crain Highway, Suite 203 Waldorf, MD 20601



240 Stirling Crescent
 Bradford, ON. L3Z 4L5

Job	Truss	Truss Type	Qty	Ply	Buildings A-H	U1530814
N0653A	X4	Monopitch	48	1		

Alliance Truss (CA), Abbotsford, BC - V2S 7P6, 8.630 s Jul 12 2024 MiTek Industries, Inc. Thu Sep 12 02:47:53 2024 Page 1

ID:hFyjDMxrTsEK_kgkR0vWWVzFgC-RfC?PsB70Hq3NSgPqnL8w3ulTXbGKWrCDoi7JzJC?F

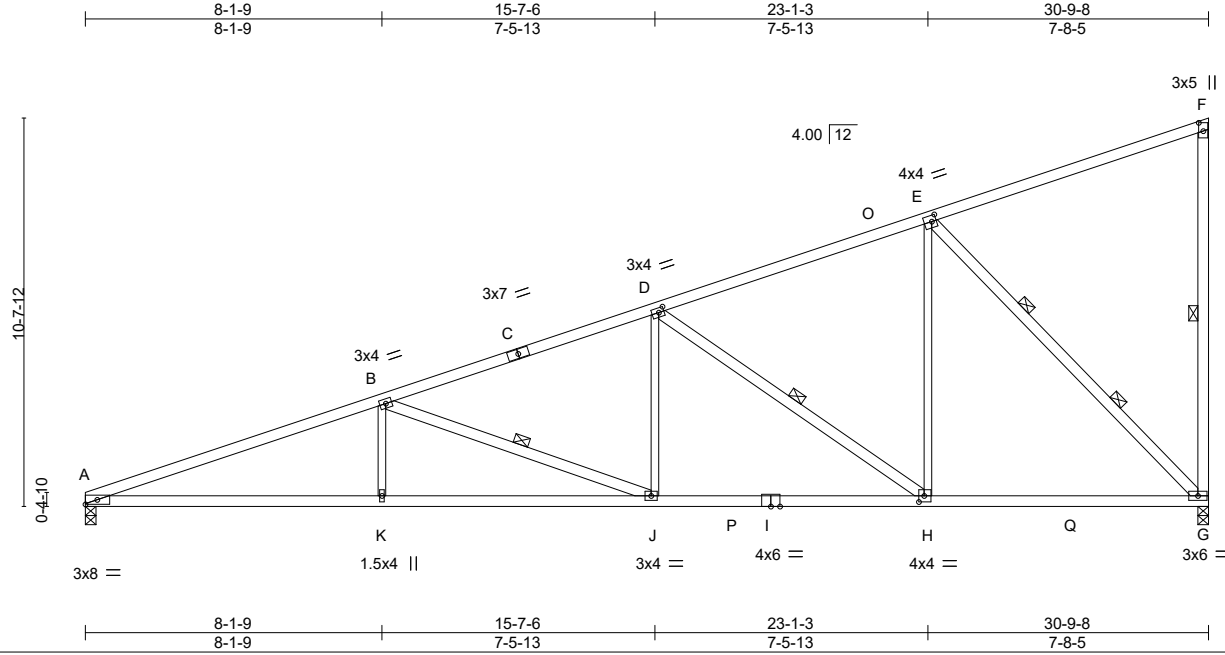

Scale = 1:63.2

Plate Offsets (X,Y)-- [D:0-1-12,0-1-8], [E:0-1-8,0-2-0], [F:0-2-12,0-1-8], [H:0-1-12,0-2-0]

LOADING (psf)	SPACING-	CSI.	DEFL.	in (loc)	l/defl	L/d	PLATES	GRIP
TCLL 25.0 (Roof Snow=25.0)	2-0-0 Plate Grip DOL 1.15	TC 0.72	Vert(LL) -0.21	J-K	>999	360	MT20	197/144
TCDL 12.0	Lumber DOL 1.15	BC 0.93	Vert(CT) -0.37	J-K	>988	240		
BCLL 0.0 *	Rep Stress Incr YES	WB 0.76	Horz(CT) 0.11	G	n/a	n/a		
BCDL 10.0	Code IBC2018/TPI2014	Matrix-MS	Wind(LL) 0.10	K-N	>999	240	Weight: 127 lb	FT = 20%

LUMBER-

TOP CHORD 2x4 SPF 2100F 1.8E
 BOT CHORD 2x4 SPF 2100F 1.8E *Except*
 G-I: 2x4 SPF No.2
 WEBS 2x4 SPF No.2 *Except*
 B-K,D-J,E-H: 2x3 SPF No.2

BRACING-

TOP CHORD Structural wood sheathing directly applied or 3-4-9 oc purlins, except end verticals.
 BOT CHORD Rigid ceiling directly applied or 10-0-0 oc bracing, Except: 2-2-0 oc bracing: H-J.
 WEBS 1 Row at midpt F-G, B-J, D-H
 2 Rows at 1/3 pts E-G

REACTIONS.

(size) G=0-3-8, A=0-3-8
 Max Horz A=338(LC 9)
 Max Uplift G=-208(LC 10), A=-156(LC 6)
 Max Grav G=1759(LC 3), A=1529(LC 3)

FORCES. (lb) - Max. Comp./Max. Ten. - All forces 250 (lb) or less except when shown.

TOP CHORD A-B=-3734/377, B-D=-2562/267, D-E=-1449/167, F-G=-367/63
 BOT CHORD A-K=-457/3482, J-K=-457/3482, H-J=-274/2358, G-H=-118/1314
 WEBS B-K=0/325, B-J=-1199/195, D-J=0/664, D-H=-1298/206, E-H=-49/1089, E-G=-1864/258

NOTES-

- 1) Wind: ASCE 7-16; Vult=115mph (3-second gust) Vasd=91mph; TCDL=4.2psf; BCDL=5.0psf; h=30ft; Ke=1.00; Cat. II; Exp B; Enclosed; MWFRS (envelope) gable end zone; cantilever left and right exposed ; end vertical left and right exposed; Lumber DOL=1.33 plate grip DOL=1.33
- 2) TCLL: ASCE 7-16; Pf=25.0 psf (Lum DOL=1.15 Plate DOL=1.15); Is=1.0; Rough Cat B; Partially Exp.; Ce=1.0; Cs=1.00; Ct=1.10
- 3) Unbalanced snow loads have been considered for this design.
- 4) This truss has been designed for a 10.0 psf bottom chord live load nonconcurrent with any other live loads.
- 5) * This truss has been designed for a live load of 20.0psf on the bottom chord in all areas where a rectangle 3-6-0 tall by 2-0-0 wide will fit between the bottom chord and any other members, with BCDL = 10.0psf.
- 6) Provide mechanical connection (by others) of truss to bearing plate capable of withstanding 100 lb uplift at joint(s) except (jt=lb) G=208, A=156.
- 7) This truss is designed in accordance with the 2018 International Building Code section 2306.1 and referenced standard ANSI/TPI 1.



September 12, 2024

WARNING - Verify design parameters and READ NOTES ON THIS AND INCLUDED MITEK REFERENCE PAGE MII-7473 rev. 6/30/2020 BEFORE USE.

Design valid for use only with MiTek® connectors. This design is based only upon parameters shown, and is for an individual building component, not a truss system. Before use, the building designer must verify the applicability of design parameters and properly incorporate this design into the overall building design. Bracing indicated is to prevent buckling of individual truss web and/or chord members only. Additional temporary and permanent bracing is always required for stability and to prevent collapse with possible personal injury and property damage. For general guidance regarding the fabrication, storage, delivery, erection and bracing of trusses and truss systems, see

Safety Information available from Truss Plate Institute, 2670 Crain Highway, Suite 203 Waldorf, MD 20601



240 Stirling Crescent
 Bradford, ON. L3Z 4L5

Job	Truss	Truss Type	Qty	Ply	Buildings A-H	U1530815
N0653A	X5	GABLE	8	1		

Job Reference (optional)

Alliance Truss (CA), Abbotsford, BC - V2S 7P6,

8.630 s Jul 12 2024 MiTek Industries, Inc. Thu Sep 12 02:47:55 2024 Page 1

ID:hFyjDMxrTsEK_kgkR0vWWVzFfgc-RfC?PsB70Hq3NSgPqnL8w3ulTXbGKWRcD0i7J4zJC?f



Scale = 1:67.5

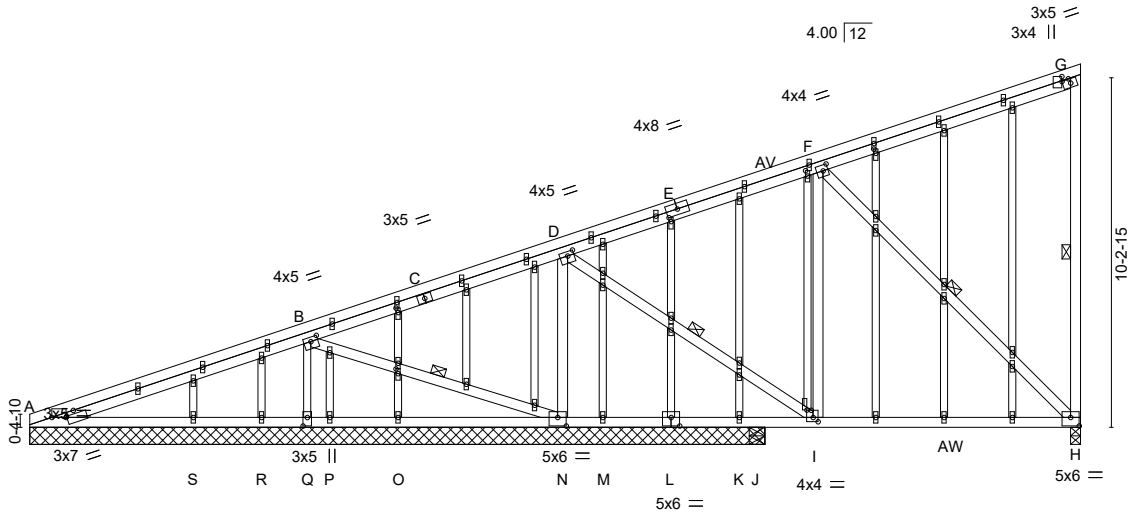

Plate Offsets (X,Y)-- [A:0-5-0,0-1-4], [B:0-2-8,0-1-8], [D:0-2-4,0-1-8], [F:0-1-12,0-2-0], [G:0-0-12,0-2-4], [G:0-2-12,0-1-8], [H:0-3-0,0-3-0], [I:0-0-1,0-1-8], [I:0-1-12,0-1-8], [L:0-3-0,0-3-0], [N:0-3-0,0-3-0], [Q:0-3-0,0-1-8], [Z:0-1-8,0-0-12], [AC:0-1-14,0-0-12], [AF:0-1-6,0-0-12], [AN:0-1-11,0-0-12], [AO:0-1-9,0-0-12], [AT:0-2-8,Edge]

LOADING (psf)	SPACING-	CSI.	DEFL.	in (loc)	l/defl	L/d	PLATES	GRIP
TCLL 25.0 (Roof Snow=25.0)	2-0-0 Plate Grip DOL 1.15	TC 0.72	Vert(LL) -0.13	H-I	>842	360	MT20	197/144
TCDL 12.0	Lumber DOL 1.15	BC 0.72	Vert(CT) -0.23	H-I	>487	240		
BCLL 0.0 *	Rep Stress Incr YES	WB 0.94	Horz(CT) -0.03	H	n/a	n/a		
BCDL 10.0	Code IBC2018/TPI2014	Matrix-MS	Wind(LL) -0.05	H-I	>999	240	Weight: 216 lb	FT = 20%

LUMBER-

TOP CHORD 2x4 SPF No.2 *Except*
C-G,A-C: 2x4 SPF 2100F 1.8E
BOT CHORD 2x4 SPF No.2
WEBS 2x4 SPF No.2 *Except*
B-Q: 2x3 SPF No.2
OTHERS 2x3 SPF No.2

BRACING-

TOP CHORD Structural wood sheathing directly applied or 4-0-8 oc purlins, except end verticals.
BOT CHORD Rigid ceiling directly applied or 3-3-4 oc bracing.
WEBS 1 Row at midpt G-H, B-N, D-I, F-H

REACTIONS.

All bearings 21-6-8 except (jt=length) H=0-3-8, J=0-5-8.
(lb) - Max Horz A=372(LC 38)
Max Uplift All uplift 100 lb or less at joint(s) P, R, S except H=872(LC 40), A=-1004(LC 31), Q=-1526(LC 39), N=-981(LC 31), J=-318(LC 18)
Max Grav All reactions 250 lb or less at joint(s) M, O, P, R, J except H=1507(LC 27), A=1129(LC 50), Q=1622(LC 28), N=1677(LC 28), K=291(LC 18), S=268(LC 29), A=302(LC 1)

FORCES.

(lb) - Max. Comp./Max. Ten. - All forces 250 (lb) or less except when shown.
TOP CHORD A-B=-3240/2962, B-D=-3490/3268, D-F=-3315/3036, F-G=-2063/1943, G-H=-365/63
BOT CHORD A-S=-2591/2512, R-S=-1485/1406, Q-R=-799/720, P-Q=-376/286, O-P=-759/682, N-O=-2414/2337, M-N=-789/675, K-M=-2202/2088, J-K=-2370/2267, I-J=-2380/2267, H-I=-853/1112
WEBS B-Q=-1589/1590, B-N=-2137/2135, D-N=-2036/1680, D-I=-1800/2008, F-I=-992/1119, F-H=-1543/1208

NOTES-

- 1) Wind: ASCE 7-16; Vult=115mph (3-second gust) Vasd=91mph; TCDL=4.2psf; BCDL=5.0psf; h=30ft; Ke=1.00; Cat. II; Exp B; Enclosed; MWFRS (envelope) gable end zone; cantilever left and right exposed ; end vertical left and right exposed; Lumber DOL=1.33 plate grip DOL=1.33
- 2) Truss designed for wind loads in the plane of the truss only. For studs exposed to wind (normal to the face), see Standard Industry Gable End Details as applicable, or consult qualified building designer as per ANSI/TPI 1.
- 3) TCLL: ASCE 7-16; Pf=25.0 psf (Lum DOL=1.15 Plate DOL=1.15); Is=1.0; Rough Cat B; Partially Exp.; Ce=1.0; Cs=1.00; Ct=1.10
- 4) Unbalanced snow loads have been considered for this design.
- 5) All plates are 1.5x4 MT20 unless otherwise indicated.
- 6) Gable studs spaced at 2-0-0 oc.
- 7) This truss has been designed for a 10.0 psf bottom chord live load nonconcurrent with any other live loads.
- 8) * This truss has been designed for a live load of 20.0psf on the bottom chord in all areas where a rectangle 3-6-0 tall by 2-0-0 wide will fit between the bottom chord and any other members, with BCDL = 10.0psf.
- 9) Provide mechanical connection (by others) of truss to bearing plate capable of withstanding 100 lb uplift at joint(s) P, R, S except (jt=lb) H=872, A=1004, Q=1526, N=981, J=318, A=1004.



September 12, 2024

Continued on page 2

WARNING - Verify design parameters and READ NOTES ON THIS AND INCLUDED MITEK REFERENCE PAGE MII-7473 rev. 6/30/2020 BEFORE USE.
Design valid for use only with MiTek® connectors. This design is based only upon parameters shown, and is for an individual building component, not a truss system. Before use, the building designer must verify the applicability of design parameters and properly incorporate this design into the overall building design. Bracing indicated is to prevent buckling of individual truss web and/or chord members only. Additional temporary and permanent bracing is always required for stability and to prevent collapse with possible personal injury and property damage. For general guidance regarding the fabrication, storage, delivery, erection and bracing of trusses and truss systems, see **ANSI/TPI1 Quality Criteria, DSB-89 and BCSI Building Component Safety Information** available from Truss Plate Institute, 2670 Crain Highway, Suite 203 Waldorf, MD 20601



Job	Truss	Truss Type	Qty	Ply	Buildings A-H	U1530815
N0653A	X5	GABLE	8	1	Job Reference (optional)	

Alliance Truss (CA), Abbotsford, BC - V2S 7P6,

8.630 s Jul 12 2024 MiTek Industries, Inc. Thu Sep 12 02:47:55 2024 Page 2
 ID:hFyjDMxrTsEK_kgkR0vWWVzFgc-RfC?PsB70Hq3NSgPqnL8w3ulTXbGKWrCDoi7J4zJC?f

NOTES-

- 10) This truss is designed in accordance with the 2018 International Building Code section 2306.1 and referenced standard ANSI/TPI 1.
- 11) This truss has been designed for a total drag load of 240 plf. Lumber DOL=(1.33) Plate grip DOL=(1.33) Connect truss to resist drag loads along bottom chord from 0-0-0 to 21-6-8 for 343.1 plf.
- 12) No notches allowed in overhang and 0 from left end and 0 from right end or 12" along rake from scarf, whichever is larger. Minimum 1.5x4 tie plates required at 2-0-0 o.c. maximum between the stacking chords. For edge-wise notching, provide at least one tie plate between each notch.

WARNING - Verify design parameters and READ NOTES ON THIS AND INCLUDED MITEK REFERANCE PAGE MII-7473 rev. 6/30/2020 BEFORE USE.

Design valid for use only with MiTek® connectors. This design is based only upon parameters shown, and is for an individual building component, not a truss system. Before use, the building designer must verify the applicability of design parameters and properly incorporate this design into the overall building design. Bracing indicated is to prevent buckling of individual truss web and/or chord members only. Additional temporary and permanent bracing is always required for stability and to prevent collapse with possible personal injury and property damage. For general guidance regarding the fabrication, storage, delivery, erection and bracing of trusses and truss systems, see

Safety Information available from Truss Plate Institute, 2670 Crain Highway, Suite 203 Waldorf, MD 20601

ANSI/TPI1 Quality Criteria, DSB-89 and BCSI Building Component



240 Stirling Crescent
 Bradford, ON. L3Z 4L5

Job	Truss	Truss Type	Qty	Ply	Buildings A-H	U1530816
N0653A	Y1	GABLE	12	1		

Alliance Truss (CA), Abbotsford, BC - V2S 7P6, 8.630 s Jul 12 2024 MiTek Industries, Inc. Thu Sep 12 02:47:57 2024 Page 1

ID:hFyjDMxrTsEK_kgkR0vWWVzFfgc-RfC?PsB70Hq3NSgPqnL8w3ulTXbGKWrCD0i7J4zJC?7

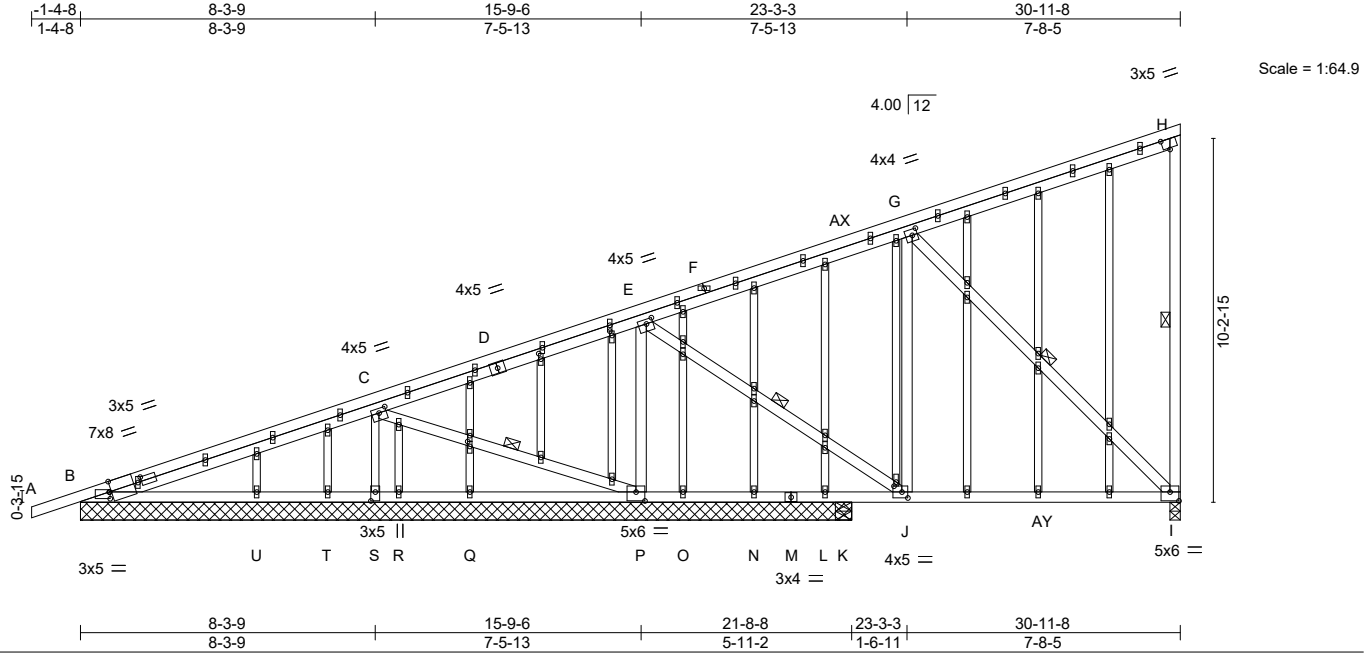

Plate Offsets (X,Y)-- [B:0-0-11,Edge], [B:0-11-7,0-1-8], [B:0-0-4,0-2-4], [C:0-2-8,0-1-8], [E:0-2-4,0-1-8], [G:0-1-12,0-2-0], [H:0-2-3,Edge], [I:0-3-0,0-3-0], [J:0-2-0,0-2-0], [J:0-1-6,0-0-12], [P:0-3-0,0-3-0], [S:0-3-0,0-1-8], [AM:0-1-7,0-0-12], [AO:0-1-14,0-0-12], [AP:0-1-11,0-0-12]

LOADING (psf)	SPACING-	CSI.	DEFL.	in (loc)	l/defl	L/d	PLATES	GRIP
TCLL 25.0	2-0-0	TC 0.98	Vert(LL) -0.13	I-J	>841	360	MT20	197/144
(Roof Snow=25.0)	Plate Grip DOL 1.15	BC 0.72	Vert(CT) -0.23	I-J	>487	240		
TCDL 12.0	Lumber DOL 1.15	WB 0.98	Horz(CT) -0.03	I	n/a	n/a		
BCLL 0.0 *	Rep Stress Incr YES	Matrix-MS	Wind(LL) -0.05	I-J	>999	240	Weight: 218 lb	FT = 20%
BCDL 10.0	Code IBC2018/TPI2014							

LUMBER-	BRACING-
TOP CHORD 2x4 SPF No.2 *Except*	TOP CHORD Structural wood sheathing directly applied, except end verticals.
D-H,A-F: 2x4 SPF 2100F 1.8E	BOT CHORD Rigid ceiling directly applied or 3-6-4 oc bracing.
BOT CHORD 2x4 SPF No.2	WEBS 1 Row at midpt H-I, C-P, E-J, G-I
WEBS 2x4 SPF No.2 *Except*	
C-S: 2x3 SPF No.2	
OTHERS 2x3 SPF No.2	

REACTIONS. All bearings 21-8-8 except (jt=length) I=0-3-8, K=0-5-8.
 (lb) - Max Horz B=805(LC 35)
 Max Uplift All uplift 100 lb or less at joint(s) L, O, R, U except I=-905(LC 41), B=-1107(LC 32), S=-1564(LC 40), P=-1031(LC 32), T=-119(LC 1), K=-218(LC 19)
 Max Grav All reactions 250 lb or less at joint(s) L, N, Q, R, T, K except I=1537(LC 28), B=1202(LC 29), S=1662(LC 29), P=1764(LC 29), U=355(LC 26), B=492(LC 1)

FORCES. (lb) - Max. Comp./Max. Ten. - All forces 250 (lb) or less except when shown.
 TOP CHORD B-C=-3338/3068, C-E=-3380/3168, E-G=-3278/3005, G-H=-2062/1943, H-I=-369/63
 BOT CHORD B-U=-2446/2358, T-U=-1359/1255, S-T=-658/570, R-S=-253/165, Q-R=-920/818, P-Q=-2571/2469, O-P=-936/815, N-O=-1621/1499, L-N=-2306/2184, K-L=-2475/2362, J-K=-2484/2362, I-J=-887/1139
 WEBS C-S=-1590/1578, C-P=-2166/2183, E-P=-2102/1747, E-J=-1871/2083, G-J=-1034/1156, G-I=-1582/1255

- NOTES-**
- 1) Wind: ASCE 7-16; Vult=115mph (3-second gust) Vasd=91mph; TCDL=4.2psf; BCDL=5.0psf; h=30ft; Ke=1.00; Cat. II; Exp B; Enclosed; MWFRS (envelope) gable end zone; cantilever left and right exposed; end vertical left and right exposed; Lumber DOL=1.33 plate grip DOL=1.33
 - 2) Truss designed for wind loads in the plane of the truss only. For studs exposed to wind (normal to the face), see Standard Industry Gable End Details as applicable, or consult qualified building designer as per ANSI/TPI 1.
 - 3) TCLL: ASCE 7-16; Pf=25.0 psf (Lum DOL=1.15 Plate DOL=1.15); Is=1.0; Rough Cat B; Partially Exp.; Ce=1.0; Cs=1.00; Ct=1.10
 - 4) Unbalanced snow loads have been considered for this design.
 - 5) This truss has been designed for greater of min roof live load of 20.0 psf or 2.00 times flat roof load of 25.0 psf on overhangs non-concurrent with other live loads.
 - 6) All plates are 1.5x4 MT20 unless otherwise indicated.
 - 7) Gable studs spaced at 2-0-0 oc.
 - 8) This truss has been designed for a 10.0 psf bottom chord live load nonconcurrent with any other live loads.
 - 9) * This truss has been designed for a live load of 20.0psf on the bottom chord in all areas where a rectangle 3-6-0 tall by 2-0-0 wide will fit between the bottom chord and any other members, with BCDL = 10.0psf.
 - 10) Provide mechanical connection (by others) of truss to bearing plate capable of withstanding 100 lb uplift at joint(s) L, O, R, U except



September 12, 2024

WARNING - Verify design parameters and READ NOTES ON THIS AND INCLUDED MITEK REFERENCE PAGE MII-7473 rev. 6/30/2020 BEFORE USE.
 Design valid for use only with MiTek® connectors. This design is based only upon parameters shown, and is for an individual building component, not a truss system. Before use, the building designer must verify the applicability of design parameters and properly incorporate this design into the overall building design. Bracing indicated is to prevent buckling of individual truss web and/or chord members only. Additional temporary and permanent bracing is always required for stability and to prevent collapse with possible personal injury and property damage. For general guidance regarding the fabrication, storage, delivery, erection and bracing of trusses and truss systems, see **ANSI/TPI1 Quality Criteria, DSB-89 and BCSI Building Component Safety Information** available from Truss Plate Institute, 2670 Crain Highway, Suite 203 Waldorf, MD 20601



Job	Truss	Truss Type	Qty	Ply	Buildings A-H	U1530816
N0653A	Y1	GABLE	12	1	Job Reference (optional)	

Alliance Truss (CA), Abbotsford, BC - V2S 7P6,

8.630 s Jul 12 2024 MiTek Industries, Inc. Thu Sep 12 02:47:57 2024 Page 2
ID:hFyjDMxrTsEK_kgkR0vWWVzFgc-RfC?PsB70Hq3NSgPqnL8w3ulTXbGKWrCDoi7J4zJC?f

NOTES-

- 11) This truss is designed in accordance with the 2018 International Building Code section 2306.1 and referenced standard ANSI/TPI 1.
- 12) This truss has been designed for a total drag load of 240 plf. Lumber DOL=(1.33) Plate grip DOL=(1.33) Connect truss to resist drag loads along bottom chord from 0-0-0 to 21-8-8 for 342.3 plf.
- 13) No notches allowed in overhang and 10408 from left end and 0 from right end or 12" along rake from scarf, whichever is larger. Minimum 1.5x4 tie plates required at 2-0-0 o.c. maximum between the stacking chords. For edge-wise notching, provide at least one tie plate between each notch.

WARNING - Verify design parameters and READ NOTES ON THIS AND INCLUDED MITEK REFERANCE PAGE MII-7473 rev. 6/30/2020 BEFORE USE.

Design valid for use only with MiTek® connectors. This design is based only upon parameters shown, and is for an individual building component, not a truss system. Before use, the building designer must verify the applicability of design parameters and properly incorporate this design into the overall building design. Bracing indicated is to prevent buckling of individual truss web and/or chord members only. Additional temporary and permanent bracing is always required for stability and to prevent collapse with possible personal injury and property damage. For general guidance regarding the fabrication, storage, delivery, erection and bracing of trusses and truss systems, see

Safety Information available from Truss Plate Institute, 2670 Crain Highway, Suite 203 Waldorf, MD 20601

ANSI/TPI1 Quality Criteria, DSB-89 and BCSI Building Component



240 Stirling Crescent
Bradford, ON. L3Z 4L5

Job N0653A	Truss Y2A	Truss Type Monopitch	Qty 66	Ply 1	Buildings A-H Job Reference (optional)	U1530898
---------------	--------------	-------------------------	-----------	----------	---	----------

Alliance Truss (CA), Abbotsford, BC - V2S 7P6,

8.820 s Aug 30 2024 MiTek Industries, Inc. Thu Sep 12 02:48:40 2024 Page 1

ID:hFyjDMxrTsEK_kgkR0vWWVzFlgc-8FCp2STZ_N6f7yR6b1aCNGQHBYdmbgY5y4cWwyeVqb

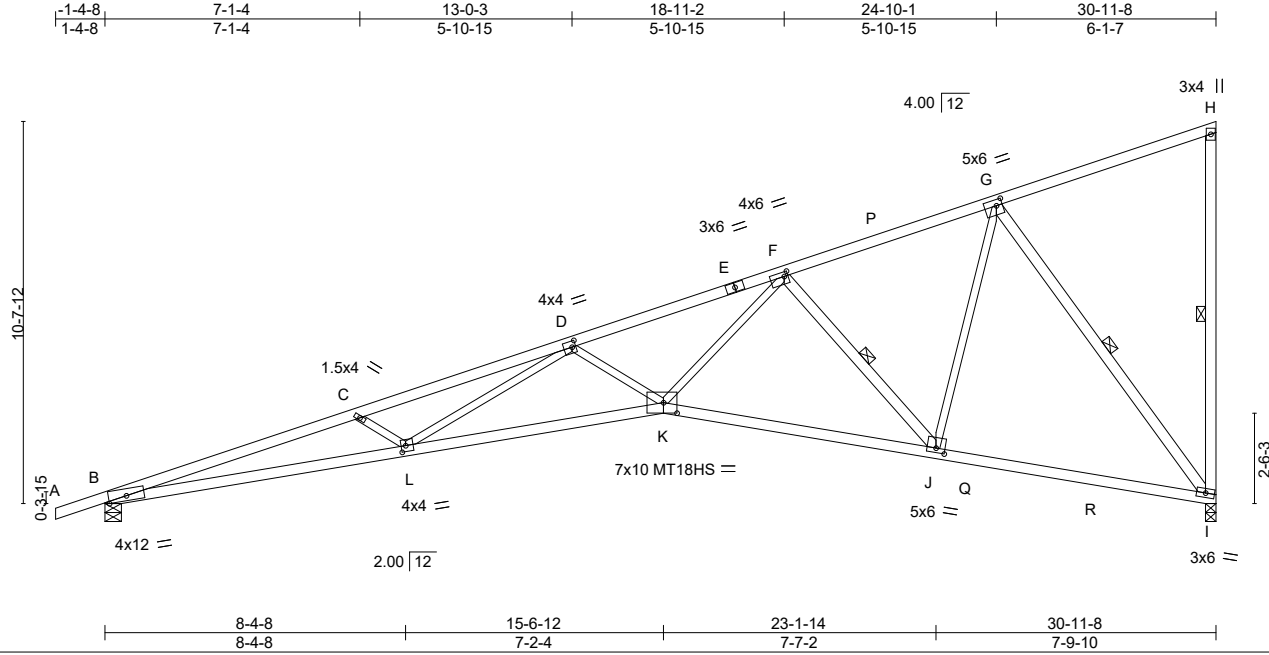

Scale: 3/16"=1'

Plate Offsets (X,Y)-- [D:0-1-4,0-2-0], [F:0-1-4,0-1-8], [G:0-2-0,0-2-0], [J:0-3-0,0-1-8], [K:0-4-8,0-3-8], [L:0-1-8,0-2-0]

LOADING (psf)	SPACING-	2-0-0	CSI.	DEFL.	in (loc)	l/defl	L/d	PLATES	GRIP	
TCLL 25.0 (Roof Snow=25.0)	Plate Grip DOL	1.15	TC 0.83	Vert(LL)	-0.64	K-L	>578	360	MT20	197/144
TCDL 12.0	Lumber DOL	1.15	BC 0.87	Vert(CT)	-1.14	K-L	>323	240	MT18HS	197/144
BCLL 0.0 *	Rep Stress Incr	YES	WB 0.97	Horz(CT)	0.47	I	n/a	n/a		
BCDL 10.0	Code IBC2018/TPI2014		Matrix-MS	Wind(LL)	0.33	K-L	>999	240		
									Weight: 123 lb	FT = 20%

LUMBER-

TOP CHORD 2x4 SPF No.2 *Except*
A-E: 2x4 SPF 2100F 1.8E
BOT CHORD 2x4 SPF 2100F 1.8E
WEBS 2x3 SPF No.2 *Except*
H-I, F-J, G-I: 2x4 SPF No.2

BRACING-

TOP CHORD Structural wood sheathing directly applied or 2-2-0 oc purlins, except end verticals.
BOT CHORD Rigid ceiling directly applied or 8-3-2 oc bracing.
WEBS 1 Row at midpt H-I, F-J, G-I

REACTIONS.

(size) I=0-3-8, B=0-5-8
Max Horz B=347(LC 9)
Max Uplift I=-209(LC 10), B=-202(LC 6)
Max Grav I=1774(LC 3), B=1624(LC 3)

FORCES. (lb) - Max. Comp./Max. Ten. - All forces 250 (lb) or less except when shown.

TOP CHORD B-C=-6947/816, C-D=-6607/733, D-F=-4823/535, F-G=-1666/190, H-I=-287/49
BOT CHORD B-L=-901/6640, K-L=-685/5302, J-K=-314/2762, I-J=-132/1215
WEBS C-L=-456/167, D-L=-93/1238, D-K=-901/211, F-K=-294/2743, F-J=-1862/308,
G-J=-125/1553, G-I=-1987/261

NOTES-

- 1) Wind: ASCE 7-16; Vult=115mph (3-second gust) Vasd=91mph; TCDL=4.2psf; BCDL=5.0psf; h=30ft; Ke=1.00; Cat. II; Exp B; Enclosed; MWFRS (envelope) gable end zone; cantilever left and right exposed; end vertical left and right exposed; Lumber DOL=1.33 plate grip DOL=1.33
- 2) TCLL: ASCE 7-16; Pf=25.0 psf (Lum DOL = 1.15 Plate DOL = 1.15); Is=1.0; Rough Cat B; Partially Exp.; Ce=1.0; Cs=1.00; Ct=1.10
- 3) Unbalanced snow loads have been considered for this design.
- 4) This truss has been designed for greater of min roof live load of 20.0 psf or 2.00 times flat roof load of 25.0 psf on overhangs non-concurrent with other live loads.
- 5) All plates are MT20 plates unless otherwise indicated.
- 6) This truss has been designed for a 10.0 psf bottom chord live load nonconcurrent with any other live loads.
- 7) * This truss has been designed for a live load of 20.0psf on the bottom chord in all areas where a rectangle 3-6-0 tall by 2-0-0 wide will fit between the bottom chord and any other members, with BCDL = 10.0psf.
- 8) Bearing at joint(s) I, B considers parallel to grain value using ANSI/TPI 1 angle to grain formula. Building designer should verify capacity of bearing surface.
- 9) Provide mechanical connection (by others) of truss to bearing plate capable of withstanding 100 lb uplift at joint(s) except (jt=lb) I=209, B=202.
- 10) This truss is designed in accordance with the 2018 International Building Code section 2306.1 and referenced standard ANSI/TPI 1.



September 12, 2024

WARNING - Verify design parameters and READ NOTES ON THIS AND INCLUDED MITEK REFERENCE PAGE MII-7473 rev. 6/30/2020 BEFORE USE.

Design valid for use only with MiTek® connectors. This design is based only upon parameters shown, and is for an individual building component, not a truss system. Before use, the building designer must verify the applicability of design parameters and properly incorporate this design into the overall building design. Bracing indicated is to prevent buckling of individual truss web and/or chord members only. Additional temporary and permanent bracing is always required for stability and to prevent collapse with possible personal injury and property damage. For general guidance regarding the fabrication, storage, delivery, erection and bracing of trusses and truss systems, see

Safety Information available from Truss Plate Institute, 2670 Crain Highway, Suite 203 Waldorf, MD 20601
ANSI/TPI1 Quality Criteria, DSB-89 and BCSI Building Component



240 Stirling Crescent
Bradford, ON. L3Z 4L5

Job N0653A	Truss Y3A	Truss Type Monopitch	Qty 6	Ply 1	Buildings A-H	U1530899
---------------	--------------	-------------------------	----------	----------	---------------	----------

Alliance Truss (CA), Abbotsford, BC - V2S 7P6, 8.820 s Aug 30 2024 MiTek Industries, Inc. Thu Sep 12 02:48:41 2024 Page 1

ID:hFyjDMxrTsEK_kgkR0vWVvzFlgc-dRIBFoUCIhEWI60J8k5RvTzTAYzpa20IKcp92MMyeVqa

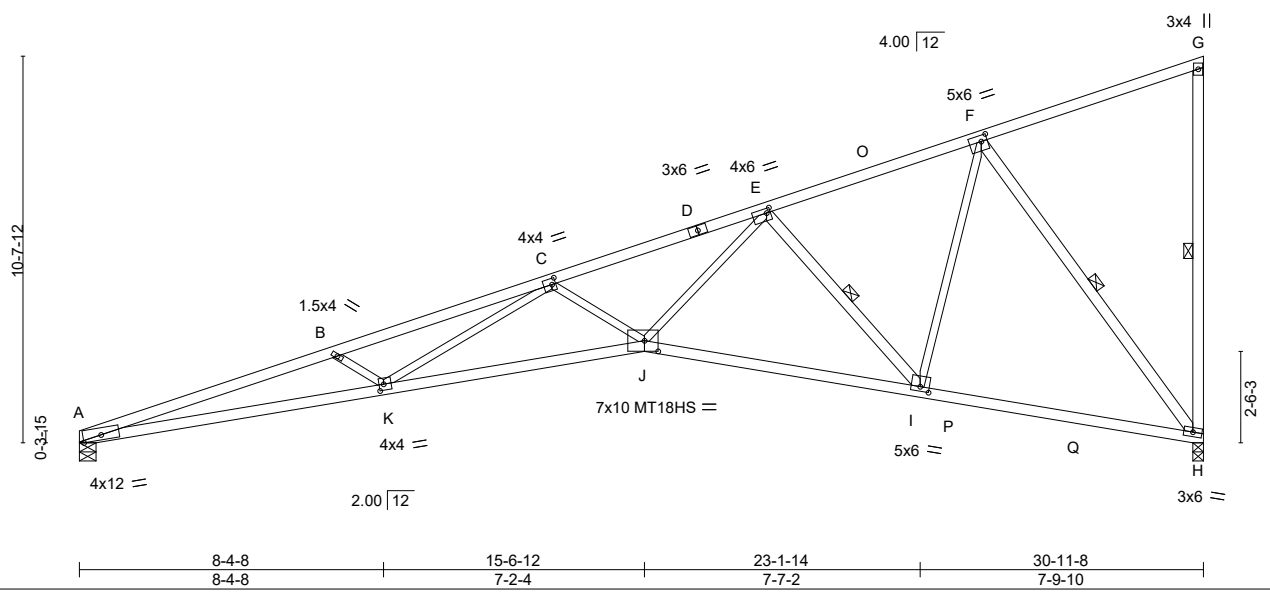

Scale: 3/16"=1'

Plate Offsets (X,Y)-- [C:0-1-4,0-2-0], [E:0-1-4,0-1-8], [F:0-2-0,0-2-0], [I:0-3-0,0-1-8], [J:0-4-8,0-3-8], [K:0-1-8,0-2-0]

LOADING (psf)	SPACING-	CSI.	DEFL.	in (loc)	l/defl	L/d	PLATES	GRIP
TCLL 25.0 (Roof Snow=25.0)	2-0-0	TC 0.82	Vert(LL)	-0.64	J-K	>579	MT20	197/144
TCDL 12.0	Lumber DOL 1.15	BC 0.88	Vert(CT)	-1.14	J-K	>323	MT18HS	197/144
BCLL 0.0 *	Rep Stress Incr YES	WB 0.96	Horz(CT)	0.47	H	n/a		
BCDL 10.0	Code IBC2018/TPI2014	Matrix-MS	Wind(LL)	0.33	J-K	>999		
							Weight: 121 lb	FT = 20%

LUMBER-

TOP CHORD 2x4 SPF No.2 *Except*
A-D: 2x4 SPF 2100F 1.8E
BOT CHORD 2x4 SPF 2100F 1.8E
WEBS 2x3 SPF No.2 *Except*
G-H,E-I,F-H: 2x4 SPF No.2

BRACING-

TOP CHORD Structural wood sheathing directly applied or 2-2-0 oc purlins, except end verticals.
BOT CHORD Rigid ceiling directly applied or 8-2-7 oc bracing.
WEBS 1 Row at midpt G-H, E-I, F-H

REACTIONS.

(size) H=0-3-8, A=0-5-8
Max Horz A=340(LC 9)
Max Uplift H=-209(LC 10), A=-157(LC 6)
Max Grav H=1764(LC 3), A=1535(LC 3)

FORCES. (lb) - Max. Comp./Max. Ten. - All forces 250 (lb) or less except when shown.

TOP CHORD A-B=-6974/830, B-C=-6628/745, C-E=-4815/539, E-F=-1658/191, G-H=-285/49
BOT CHORD A-K=-914/6667, J-K=-689/5299, I-J=-316/2753, H-I=-132/1208
WEBS B-K=-466/170, C-K=-102/1264, C-J=-908/213, E-J=-297/2744, E-I=-1858/309, F-I=-126/1550, F-H=-1973/262

NOTES-

- Wind: ASCE 7-16; Vult=115mph (3-second gust) Vasd=91mph; TCDL=4.2psf; BCDL=5.0psf; h=30ft; Ke=1.00; Cat. II; Exp B; Enclosed; MWFRS (envelope) gable end zone; cantilever left and right exposed; end vertical left and right exposed; Lumber DOL=1.33 plate grip DOL=1.33
- TCLL: ASCE 7-16; Pf=25.0 psf (Lum DOL = 1.15 Plate DOL = 1.15); Is=1.0; Rough Cat B; Partially Exp.; Ce=1.0; Cs=1.00; Ct=1.10
- Unbalanced snow loads have been considered for this design.
- All plates are MT20 plates unless otherwise indicated.
- This truss has been designed for a 10.0 psf bottom chord live load nonconcurrent with any other live loads.
- * This truss has been designed for a live load of 20.0psf on the bottom chord in all areas where a rectangle 3-6-0 tall by 2-0-0 wide will fit between the bottom chord and any other members, with BCDL = 10.0psf.
- Bearing at joint(s) H, A considers parallel to grain value using ANSI/TPI 1 angle to grain formula. Building designer should verify capacity of bearing surface.
- Provide mechanical connection (by others) of truss to bearing plate capable of withstanding 100 lb uplift at joint(s) except (jt=lb) H=209, A=157.
- This truss is designed in accordance with the 2018 International Building Code section 2306.1 and referenced standard ANSI/TPI 1.



September 12, 2024

WARNING - Verify design parameters and READ NOTES ON THIS AND INCLUDED MITEK REFERENCE PAGE MII-7473 rev. 6/30/2020 BEFORE USE.

Design valid for use only with MiTek® connectors. This design is based only upon parameters shown, and is for an individual building component, not a truss system. Before use, the building designer must verify the applicability of design parameters and properly incorporate this design into the overall building design. Bracing indicated is to prevent buckling of individual truss web and/or chord members only. Additional temporary and permanent bracing is always required for stability and to prevent collapse with possible personal injury and property damage. For general guidance regarding the fabrication, storage, delivery, erection and bracing of trusses and truss systems, see

ANSI/TPI1 Quality Criteria, DSB-89 and BCSI Building Component Safety Information available from Truss Plate Institute, 2670 Crain Highway, Suite 203 Waldorf, MD 20601



240 Stirling Crescent
Bradford, ON. L3Z 4L5

Job	Truss	Truss Type	Qty	Ply	Buildings A-H	U1530817
N0653A	Y4	Monopitch	30	1		

Alliance Truss (CA), Abbotsford, BC - V2S 7P6, 8.630 s Jul 12 2024 MiTek Industries, Inc. Thu Sep 12 02:47:58 2024 Page 1

ID:hFyjDMxrTsEK_kgkR0vWWVzFfgc-RfC?PsB70Hq3NSgPqnL8w3ulTXbGKWrCDoi7J4zJC?f

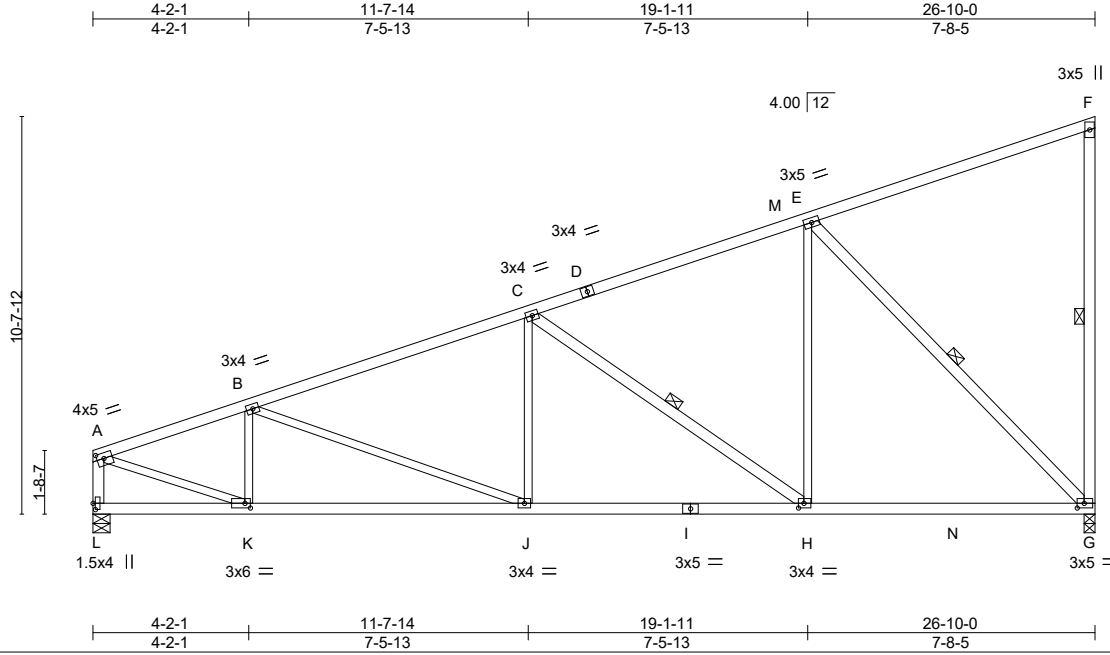

Plate Offsets (X,Y)-- [A:0-2-4,0-1-12], [G:0-2-4,0-1-8], [H:0-1-12,0-1-8], [K:0-1-12,0-1-8], [L:0-2-0,0-0-12]

LOADING (psf)	SPACING-	CSI.	DEFL.	in (loc)	l/defl	L/d	PLATES	GRIP
TCLL 25.0 (Roof Snow=25.0)	2-0-0 Plate Grip DOL 1.15	TC 0.70	Vert(LL)	-0.16 G-H	>999	360	MT20	197/144
TCDL 12.0	Lumber DOL 1.15	BC 0.79	Vert(CT)	-0.26 G-H	>999	240		
BCLL 0.0 *	Rep Stress Incr YES	WB 0.83	Horz(CT)	0.06 G	n/a	n/a		
BCDL 10.0	Code IBC2018/TPI2014	Matrix-MS	Wind(LL)	0.05 G-H	>999	240	Weight: 120 lb	FT = 20%

LUMBER-

TOP CHORD 2x4 SPF 2100F 1.8E *Except*
A-D: 2x4 SPF No.2
BOT CHORD 2x4 SPF No.2
WEBS 2x3 SPF No.2 *Except*
F-G,C-H,E-G,A-L: 2x4 SPF No.2

BRACING-

TOP CHORD Structural wood sheathing directly applied or 3-0-7 oc purlins, except end verticals.
BOT CHORD Rigid ceiling directly applied or 10-0-0 oc bracing.
WEBS 1 Row at midpt F-G, C-H, E-G

REACTIONS.

(size) G=0-3-8, L=0-5-8
Max Horz L=333(LC 7)
Max Uplift G=-186(LC 10), L=-130(LC 6)
Max Grav G=1520(LC 3), L=1328(LC 3)

FORCES. (lb) - Max. Comp./Max. Ten. - All forces 250 (lb) or less except when shown.

TOP CHORD A-B=-1868/185, B-C=-1925/200, C-E=-1212/145, F-G=-358/63, A-L=-1278/140
BOT CHORD K-L=-318/42, J-K=-270/1749, H-J=-214/1759, G-H=-122/1089
WEBS B-K=-487/125, C-J=0/306, C-H=-851/158, E-H=-20/828, E-G=-1540/227, A-K=-173/1821

NOTES-

- 1) Wind: ASCE 7-16; Vult=115mph (3-second gust) Vasd=91mph; TCDL=4.2psf; BCDL=5.0psf; h=30ft; Ke=1.00; Cat. II; Exp B; Enclosed; MWFRS (envelope) gable end zone; cantilever left and right exposed ; end vertical left and right exposed; Lumber DOL=1.33 plate grip DOL=1.33
- 2) TCLL: ASCE 7-16; Pf=25.0 psf (Lum DOL=1.15 Plate DOL=1.15); Is=1.0; Rough Cat B; Partially Exp.; Ce=1.0; Cs=1.00; Ct=1.10
- 3) Unbalanced snow loads have been considered for this design.
- 4) This truss has been designed for a 10.0 psf bottom chord live load nonconcurrent with any other live loads.
- 5) * This truss has been designed for a live load of 20.0psf on the bottom chord in all areas where a rectangle 3-6-0 tall by 2-0-0 wide will fit between the bottom chord and any other members, with BCDL = 10.0psf.
- 6) Provide mechanical connection (by others) of truss to bearing plate capable of withstanding 100 lb uplift at joint(s) except (jt=lb) G=186, L=130.
- 7) This truss is designed in accordance with the 2018 International Building Code section 2306.1 and referenced standard ANSI/TPI 1.



September 12, 2024

WARNING - Verify design parameters and READ NOTES ON THIS AND INCLUDED MITEK REFERENCE PAGE MII-7473 rev. 6/30/2020 BEFORE USE.

Design valid for use only with MiTek® connectors. This design is based only upon parameters shown, and is for an individual building component, not a truss system. Before use, the building designer must verify the applicability of design parameters and properly incorporate this design into the overall building design. Bracing indicated is to prevent buckling of individual truss web and/or chord members only. Additional temporary and permanent bracing is always required for stability and to prevent collapse with possible personal injury and property damage. For general guidance regarding the fabrication, storage, delivery, erection and bracing of trusses and truss systems, see

Safety Information available from Truss Plate Institute, 2670 Crain Highway, Suite 203 Waldorf, MD 20601



240 Stirling Crescent
Bradford, ON. L3Z 4L5

Job	Truss	Truss Type	Qty	Ply	Buildings A-H	U1530900
N0653A	Y5	GABLE	6	1		

Alliance Truss (CA), Abbotsford, BC - V2S 7P6, 8.820 s Aug 30 2024 MiTek Industries, Inc. Thu Sep 12 02:48:42 2024 Page 1
 ID:hFyjDMxrTsEK_kgkR0vWWVzFlgc-5eJZT7VqW_MNMGbViSdgShVcuMRiJVcrZGZjboyeVqZ

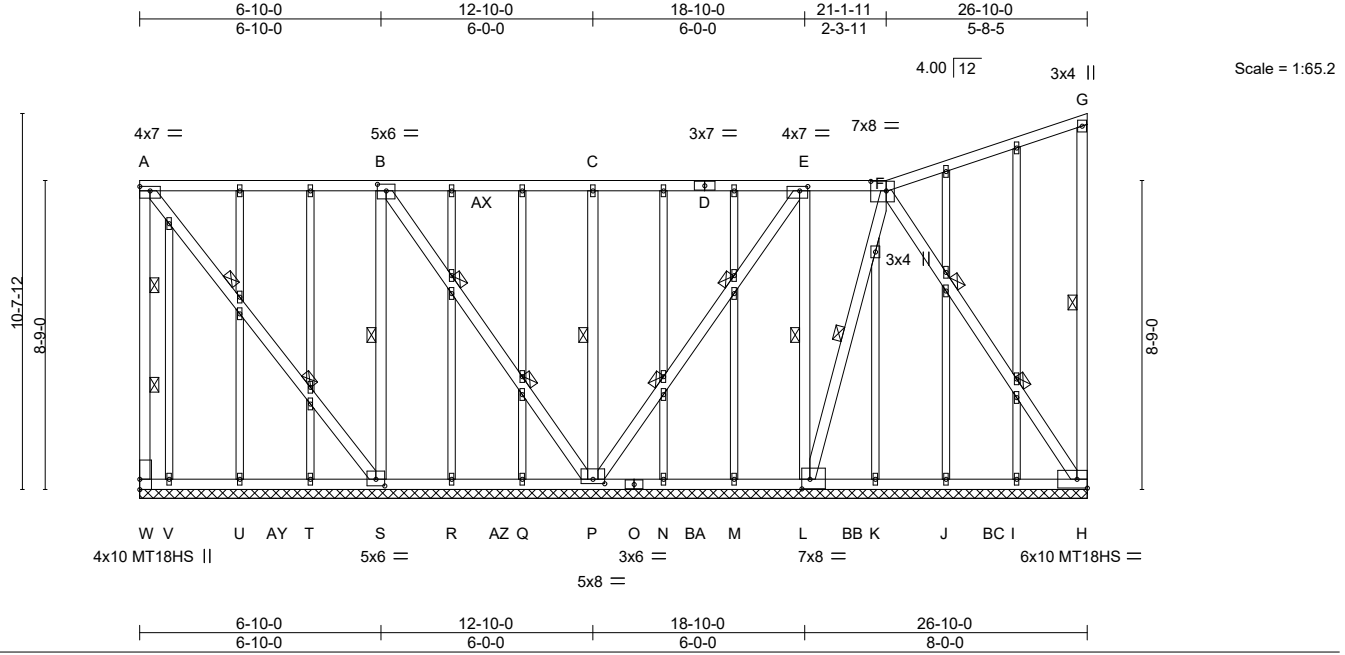

Plate Offsets (X,Y)-- [A:Edge,0-1-8], [B:0-3-0,0-2-4], [E:0-2-12,0-1-8], [F:0-5-4,0-3-4], [L:0-2-12,0-3-4], [P:0-4-0,0-1-8], [S:0-3-0,0-2-4]

LOADING (psf)	SPACING-	CSI.	DEFL.	PLATES	GRIP
TCLL 25.0 (Roof Snow=25.0)	2-0-0 Plate Grip DOL 1.15 Lumber DOL 1.15 Rep Stress Incr YES Code IBC2018/TPI2014	TC 0.88 BC 0.33 WB 1.00 Matrix-S	in (loc) l/defl L/d Vert(LL) n/a - n/a 999 Vert(CT) n/a - n/a 999 Horz(CT) -0.02 H n/a n/a	MT20 MT18HS	197/144 197/144
TCDL 12.0				Weight: 231 lb	FT = 20%
BCLL 0.0 *					
BCDL 10.0					

LUMBER-	BRACING-
TOP CHORD 2x4 SPF No.2	TOP CHORD Structural wood sheathing directly applied or 2-7-8 oc purlins, except end verticals.
BOT CHORD 2x4 SPF No.2	BOT CHORD Rigid ceiling directly applied or 4-6-12 oc bracing.
WEBS 2x4 SPF No.2	WEBS 1 Row at midpt G-H, B-S, C-P, E-L, F-L
OTHERS 2x3 SPF No.2	2 Rows at 1/3 pts A-W, A-S, B-P, E-P, F-H

REACTIONS. All bearings 26-10-0.
 (lb) - Max Horz W=173(LC 34)
 Max Uplift All uplift 100 lb or less at joint(s) except W=-2139(LC 36), H=-2305(LC 41), S=-150(LC 41), P=-226(LC 41), L=-891(LC 40), V=-119(LC 35)
 Max Grav All reactions 250 lb or less at joint(s) I, J, K, M, N, Q, R, T, U, V except W=2097(LC 35), H=2315(LC 52), S=650(LC 64), P=1112(LC 64), L=1083(LC 29)

FORCES. (lb) - Max. Comp./Max. Ten. - All forces 250 (lb) or less except when shown.
 TOP CHORD A-W=-2014/2015, A-B=-1598/1568, B-C=-1350/1315, C-E=-1662/1627, E-F=-876/827, F-G=-1443/1387, G-H=-292/69
 BOT CHORD V-W=-265/207, U-V=-745/687, T-U=-1225/1167, S-T=-1705/1647, R-S=-605/557, Q-R=-1085/1037, P-Q=-1565/1517, N-P=-1184/1160, M-N=-704/680, L-M=-307/283, K-L=-460/452, J-K=-552/543, I-J=-1032/1023, H-I=-1474/1468
 WEBS A-S=-2532/2548, B-S=-2022/2020, B-P=-2379/2377, C-P=-657/135, E-P=-2325/2308, E-L=-1883/1887, F-L=-2787/2764, F-H=-2671/2688

- NOTES-**
- 1) Wind: ASCE 7-16; Vult=115mph (3-second gust) Vasd=91mph; TCDL=4.2psf; BCDL=5.0psf; h=30ft; Ke=1.00; Cat. II; Exp B; Enclosed; MWFRS (envelope) gable end zone; cantilever left exposed; end vertical left exposed; Lumber DOL=1.33 plate grip DOL=1.33
 - 2) Truss designed for wind loads in the plane of the truss only. For studs exposed to wind (normal to the face), see Standard Industry Gable End Details as applicable, or consult qualified building designer as per ANSI/TPI 1.
 - 3) TCLL: ASCE 7-16; Pf=25.0 psf (Lum DOL = 1.15 Plate DOL = 1.15); Is=1.0; Rough Cat B; Partially Exp.; Ce=1.0; Cs=1.00; Ct=1.10
 - 4) Unbalanced snow loads have been considered for this design.
 - 5) Provide adequate drainage to prevent water ponding.
 - 6) All plates are MT20 plates unless otherwise indicated.
 - 7) All plates are 1.5x4 MT20 unless otherwise indicated.
 - 8) Gable requires continuous bottom chord bearing.
 - 9) Gable studs spaced at 2-0-0 oc.
 - 10) This truss has been designed for a 10.0 psf bottom chord live load nonconcurrent with any other live loads.
 - 11) * This truss has been designed for a live load of 20.0psf on the bottom chord in all areas where a rectangle 3-6-0 tall by 2-0-0 wide will fit between the bottom chord and any other members, with BCDL = 10.0psf.
 - 12) Provide mechanical connection (by others) of truss to bearing plate capable of withstanding 2139 lb uplift at joint W, 2305 lb uplift at joint H, 150 lb uplift at joint S, 226 lb uplift at joint P, 891 lb uplift at joint L and 119 lb uplift at joint V.
 - 13) This truss is designed in accordance with the 2018 International Building Code section 2306.1 and referenced standard ANSI/TPI



September 12, 2024

Job	Truss	Truss Type	Qty	Ply	Buildings A-H	U1530900
N0653A	Y5	GABLE	6	1	Job Reference (optional)	

Alliance Truss (CA), Abbotsford, BC - V2S 7P6,

8.820 s Aug 30 2024 MiTek Industries, Inc. Thu Sep 12 02:48:42 2024 Page 2
 ID:hFyjDMxrTsEK_kgkR0vWWWzF1gc-5eJZT7VqW_MNMGbViSdgShVcuMRiJVcrZGZjboyeVqZ

NOTES-

14) This truss has been designed for a total drag load of 240 plf. Lumber DOL=(1.33) Plate grip DOL=(1.33) Connect truss to resist drag loads along bottom chord from 0-0-0 to 26-10-0 for 240.0 plf.

 **WARNING - Verify design parameters and READ NOTES ON THIS AND INCLUDED MITEK REFERENCE PAGE MII-7473 rev. 6/30/2020 BEFORE USE.**
 Design valid for use only with MiTek® connectors. This design is based only upon parameters shown, and is for an individual building component, not a truss system. Before use, the building designer must verify the applicability of design parameters and properly incorporate this design into the overall building design. Bracing indicated is to prevent buckling of individual truss web and/or chord members only. Additional temporary and permanent bracing is always required for stability and to prevent collapse with possible personal injury and property damage. For general guidance regarding the fabrication, storage, delivery, erection and bracing of trusses and truss systems, see **ANSI/TPI1 Quality Criteria, DSB-89 and BCSI Building Component Safety Information** available from Truss Plate Institute, 2670 Crain Highway, Suite 203 Waldorf, MD 20601



Job N0653A	Truss Y6	Truss Type GABLE	Qty 6	Ply 1	Buildings A-H	U1530818
---------------	-------------	---------------------	----------	----------	---------------	----------

Alliance Truss (CA), Abbotsford, BC - V2S 7P6,

8.630 s Jul 12 2024 MiTek Industries, Inc. Thu Sep 12 02:47:59 2024 Page 1

ID:hFyjDMxrTsEK_kgkR0vWWVzFfgC-RfC?PsB70Hq3NSgPqnL8w3uTXbGKWRCDoi7J4zJC?f

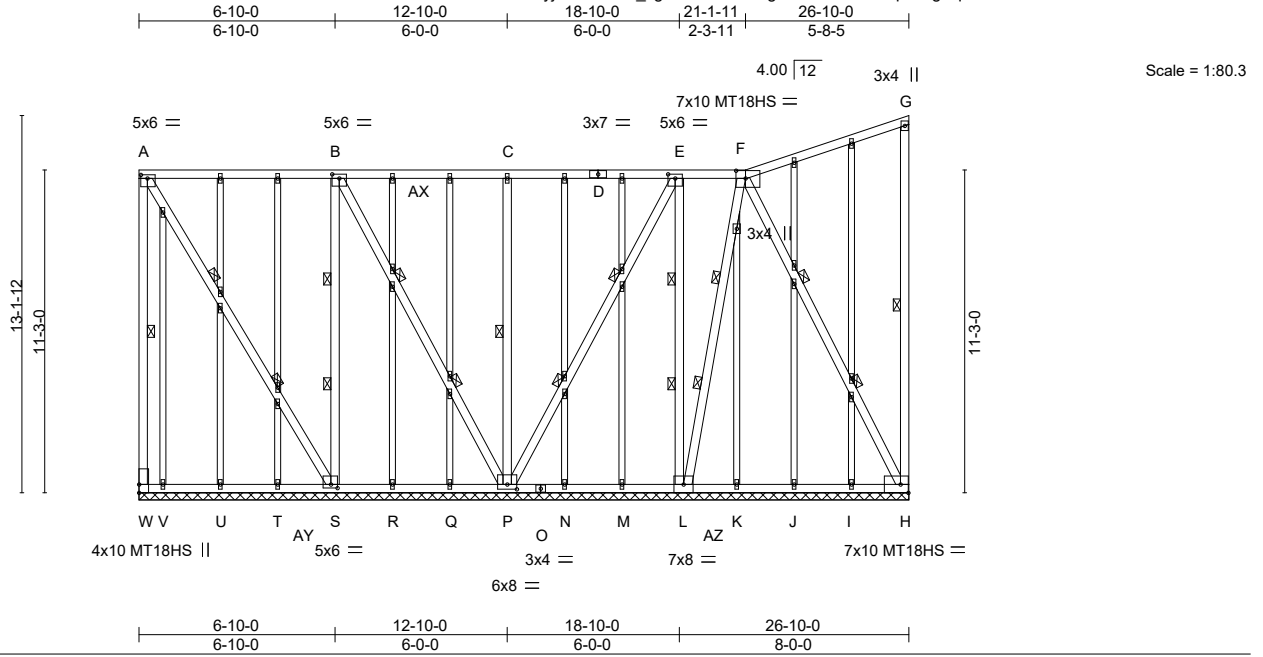

Plate Offsets (X,Y)-- [A:0-2-12,0-1-8], [B:0-3-0,0-1-12], [E:0-3-0,0-1-12], [F:0-4-0,0-3-4], [H:0-3-4,Edge], [P:0-4-0,0-2-0], [S:0-2-12,0-1-8]

LOADING (psf)	SPACING-	CSI.	DEFL.	PLATES	GRIP
TCLL 25.0 (Roof Snow=25.0)	2-0-0 Plate Grip DOL 1.15	TC 0.96	in (loc) l/defl L/d	MT20	197/144
TCDL 12.0	Lumber DOL 1.15	BC 0.32	Vert(LL) n/a - n/a 999	MT18HS	197/144
BCLL 0.0 *	Rep Stress Incr YES	WB 1.00	Vert(CT) n/a - n/a 999		
BCDL 10.0	Code IBC2018/TPI2014	Matrix-S	Horz(CT) -0.02 H n/a n/a		
				Weight: 278 lb	FT = 20%

LUMBER-

TOP CHORD 2x4 SPF No.2
 BOT CHORD 2x4 SPF No.2
 WEBS 2x4 SPF 2100F 1.8E *Except*
 G-H,B-S,C-P,E-L: 2x4 SPF No.2
 OTHERS 2x3 SPF No.2

BRACING-

TOP CHORD Structural wood sheathing directly applied or 2-7-8 oc purlins, except end verticals.
 BOT CHORD Rigid ceiling directly applied or 4-7-8 oc bracing.
 WEBS 1 Row at midpt A-W, G-H, C-P
 2 Rows at 1/3 pts A-S, B-S, B-P, E-P, E-L, F-L, F-H

REACTIONS.

All bearings 26-10-0.
 (lb) - Max Horz W=56(LC 32)
 Max Uplift All uplift 100 lb or less at joint(s) V except W=-2743(LC 32), H=-3094(LC 33), S=-471(LC 33), P=-231(LC 32), L=-1185(LC 32)
 Max Grav All reactions 250 lb or less at joint(s) I, J, K, M, N, Q, R, T, U, V except W=2772(LC 53), H=3090(LC 52), S=664(LC 28), P=1272(LC 64), L=1269(LC 29)

FORCES. (lb) - Max. Comp./Max. Ten. - All forces 250 (lb) or less except when shown.

TOP CHORD A-W=-2737/2708, A-B=-1642/1624, B-C=-1333/1313, C-E=-1652/1632, E-F=-875/850, F-G=-1442/1386, G-H=-291/71
 BOT CHORD U-V=-700/645, T-U=-1180/1125, S-T=-1660/1605, R-S=-495/454, Q-R=-975/934, P-Q=-1455/1414, N-P=-1133/1114, M-N=-653/634, L-M=-382/362, K-L=-361/349, J-K=-613/601, I-J=-1093/1081, H-I=-1538/1526
 WEBS A-S=-3132/3159, B-S=-2398/2372, B-P=-2680/2691, C-P=-657/141, E-P=-2718/2684, E-L=-2322/2339, F-L=-3521/3482, F-H=-3374/3401

NOTES-

- Wind: ASCE 7-16; Vult=115mph (3-second gust) Vasd=91mph; TCDL=4.2psf; BCDL=5.0psf; h=30ft; Ke=1.00; Cat. II; Exp B; Enclosed; MWFRS (envelope) gable end zone; Lumber DOL=1.33 plate grip DOL=1.33
- Truss designed for wind loads in the plane of the truss only. For studs exposed to wind (normal to the face), see Standard Industry Gable End Details as applicable, or consult qualified building designer as per ANSI/TPI 1.
- TCLL: ASCE 7-16; Pf=25.0 psf (Lum DOL=1.15 Plate DOL=1.15); Is=1.0; Rough Cat B; Partially Exp.; Ce=1.0; Cs=1.0; Ct=1.10
- Unbalanced snow loads have been considered for this design.
- Provide adequate drainage to prevent water ponding.
- All plates are MT20 plates unless otherwise indicated.
- All plates are 1.5x4 MT20 unless otherwise indicated.
- Gable requires continuous bottom chord bearing.
- Gable studs spaced at 2-0-0 oc.
- This truss has been designed for a 10.0 psf bottom chord live load nonconcurrent with any other live loads.
- * This truss has been designed for a live load of 20.0psf on the bottom chord in all areas where a rectangle 3-6-0 tall by 2-0-0 wide will fit between the bottom chord and any other members, with BCDL = 10.0psf.
- Provide mechanical connection (by others) of truss to bearing plate capable of withstanding 100 lb uplift at joint(s) V except (jt=lb) W=2743, H=3094, S=471, P=231, L=1185.
- This truss is designed in accordance with the 2018 International Building Code section 2306.1 and referenced standard ANSI/TPI



September 12, 2024

Continued on page 2

WARNING - Verify design parameters and READ NOTES ON THIS AND INCLUDED MITEK REFERENCE PAGE MII-7473 rev. 6/30/2020 BEFORE USE.

Design valid for use only with MiTek® connectors. This design is based only upon parameters shown, and is for an individual building component, not a truss system. Before use, the building designer must verify the applicability of design parameters and properly incorporate this design into the overall building design. Bracing indicated is to prevent buckling of individual truss web and/or chord members only. Additional temporary and permanent bracing is always required for stability and to prevent collapse with possible personal injury and property damage. For general guidance regarding the fabrication, storage, delivery, erection and bracing of trusses and truss systems, see

ANSI/TPI1 Quality Criteria, DSB-89 and BCSI Building Component

Safety Information available from Truss Plate Institute, 2670 Crain Highway, Suite 203 Waldorf, MD 20601



240 Stirling Crescent
 Bradford, ON. L3Z 4L5

Job	Truss	Truss Type	Qty	Ply	Buildings A-H	U1530818
N0653A	Y6	GABLE	6	1	Job Reference (optional)	

Alliance Truss (CA), Abbotsford, BC - V2S 7P6,

8.630 s Jul 12 2024 MiTek Industries, Inc. Thu Sep 12 02:48:00 2024 Page 2
 ID:hFyjDMxrTsEK_kgkR0vWWVzFigc-RfC?PsB70Hq3NSgPqnL8w3ulTXbGKWrCDoi7J4zJC?f

NOTES-

14) This truss has been designed for a total drag load of 240 plf. Lumber DOL=(1.33) Plate grip DOL=(1.33) Connect truss to resist drag loads along bottom chord from 0-0-0 to 26-10-0 for 240.0 plf.

 **WARNING - Verify design parameters and READ NOTES ON THIS AND INCLUDED MITEK REFERENCE PAGE MII-7473 rev. 6/30/2020 BEFORE USE.**
 Design valid for use only with MiTek® connectors. This design is based only upon parameters shown, and is for an individual building component, not a truss system. Before use, the building designer must verify the applicability of design parameters and properly incorporate this design into the overall building design. Bracing indicated is to prevent buckling of individual truss web and/or chord members only. Additional temporary and permanent bracing is always required for stability and to prevent collapse with possible personal injury and property damage. For general guidance regarding the fabrication, storage, delivery, erection and bracing of trusses and truss systems, see **ANSI/TPI1 Quality Criteria, DSB-89 and BCSI Building Component Safety Information** available from Truss Plate Institute, 2670 Crain Highway, Suite 203 Waldorf, MD 20601



Job	Truss	Truss Type	Qty	Ply	Buildings A-H	U1530819
N0653A	Y7	MONOPITCH	36	1		

Alliance Truss (CA), Abbotsford, BC - V2S 7P6, 8.630 s Jul 12 2024 MiTek Industries, Inc. Thu Sep 12 02:48:00 2024 Page 1
 ID:hFyjDMxrTsEK_kgkR0vWWVzF1gc-RfC?PsB70Hq3NSgPqnL8w3ulTXbGKWrCDoi7J4zJC?f

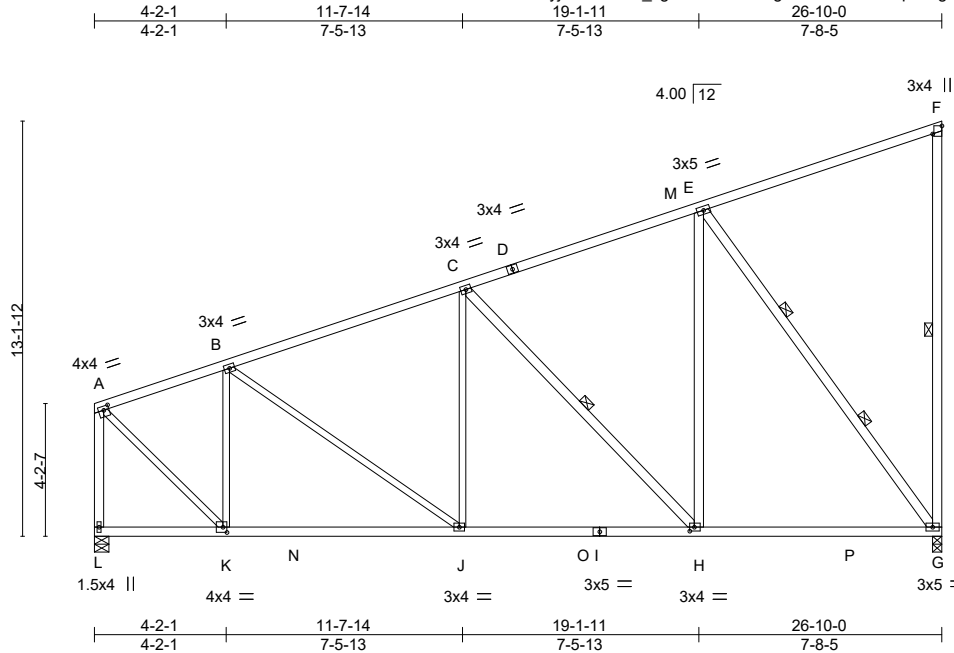

Scale = 1:73.0

Plate Offsets (X,Y)-- [A:0-2-0,0-1-8], [F:Edge,0-3-8], [H:0-1-12,0-1-8], [K:0-1-8,0-2-0]

LOADING (psf)	SPACING-	CSI.	DEFL.	PLATES	GRIP
TCLL 25.0 (Roof Snow=25.0)	2-0-0 Plate Grip DOL 1.15	TC 0.71	in (loc) l/defl L/d	MT20	197/144
TCDL 12.0	Lumber DOL 1.15	BC 0.72	Vert(LL) -0.16 G-H >999 360		
BCLL 0.0 *	Rep Stress Incr YES	WB 0.79	Vert(CT) -0.27 G-H >999 240		
BCDL 10.0	Code IBC2018/TPI2014	Matrix-MS	Horz(CT) 0.04 G n/a n/a	Weight: 141 lb	FT = 20%
			Wind(LL) 0.03 J >999 240		

LUMBER-

TOP CHORD 2x4 SPF 2100F 1.8E *Except*
 A-D: 2x4 SPF No.2
 BOT CHORD 2x4 SPF No.2
 WEBS 2x4 SPF No.2 *Except*
 B-K,B-J,C-J,A-K: 2x3 SPF No.2

BRACING-

TOP CHORD Structural wood sheathing directly applied or 4-0-8 oc purlins, except end verticals.
 BOT CHORD Rigid ceiling directly applied or 10-0-0 oc bracing.
 WEBS 1 Row at midpt F-G, C-H
 2 Rows at 1/3 pts E-G

REACTIONS.

(size) G=0-3-8, L=0-5-8
 Max Horz L=246(LC 7)
 Max Uplift G=-238(LC 10), L=-76(LC 6)
 Max Grav G=1567(LC 3), L=1384(LC 3)

FORCES. (lb) - Max. Comp./Max. Ten. - All forces 250 (lb) or less except when shown.

TOP CHORD A-B=-1040/50, B-C=-1393/71, C-E=-967/37, F-G=-357/78, A-L=-1343/85
 BOT CHORD J-K=-297/973, H-J=-248/1254, G-H=-141/856
 WEBS B-K=-758/118, B-J=0/344, C-H=-610/155, E-H=-28/801, E-G=-1426/237, A-K=-71/1355

NOTES-

- 1) Wind: ASCE 7-16; Vult=115mph (3-second gust) Vasd=91mph; TCDL=4.2psf; BCDL=5.0psf; h=30ft; Ke=1.00; Cat. II; Exp B; Enclosed; MWFRS (envelope) gable end zone; cantilever left exposed; end vertical left exposed; Lumber DOL=1.33 plate grip DOL=1.33
- 2) TCLL: ASCE 7-16; Pf=25.0 psf (Lum DOL=1.15 Plate DOL=1.15); Is=1.0; Rough Cat B; Partially Exp.; Ce=1.0; Cs=1.00; Ct=1.10
- 3) Unbalanced snow loads have been considered for this design.
- 4) This truss has been designed for a 10.0 psf bottom chord live load nonconcurrent with any other live loads.
- 5) * This truss has been designed for a live load of 20.0psf on the bottom chord in all areas where a rectangle 3-6-0 tall by 2-0-0 wide will fit between the bottom chord and any other members, with BCDL = 10.0psf.
- 6) Provide mechanical connection (by others) of truss to bearing plate capable of withstanding 100 lb uplift at joint(s) L except (jt=lb) G=238.
- 7) This truss is designed in accordance with the 2018 International Building Code section 2306.1 and referenced standard ANSI/TPI 1.



September 12, 2024

WARNING - Verify design parameters and READ NOTES ON THIS AND INCLUDED MITEK REFERENCE PAGE MII-7473 rev. 6/30/2020 BEFORE USE.

Design valid for use only with MiTek® connectors. This design is based only upon parameters shown, and is for an individual building component, not a truss system. Before use, the building designer must verify the applicability of design parameters and properly incorporate this design into the overall building design. Bracing indicated is to prevent buckling of individual truss web and/or chord members only. Additional temporary and permanent bracing is always required for stability and to prevent collapse with possible personal injury and property damage. For general guidance regarding the fabrication, storage, delivery, erection and bracing of trusses and truss systems, see **ANSI/TPI1 Quality Criteria, DSB-89 and BCSI Building Component Safety Information** available from Truss Plate Institute, 2670 Crain Highway, Suite 203 Waldorf, MD 20601



240 Stirling Crescent
 Bradford, ON. L3Z 4L5

Job	Truss	Truss Type	Qty	Ply	Buildings A-H	U1530901
N0653A	Y8A	GABLE	6	1		

Alliance Truss (CA), Abbotsford, BC - V2S 7P6, 8.820 s Aug 30 2024 MiTek Industries, Inc. Thu Sep 12 02:48:44 2024 Page 1
 ID:hFyjDMxrTsEK_kgkR0vWWVzFlgc-10RKtpW42cc5caluqtf8X6b_5A0BnRs80a2pfhyeVqX

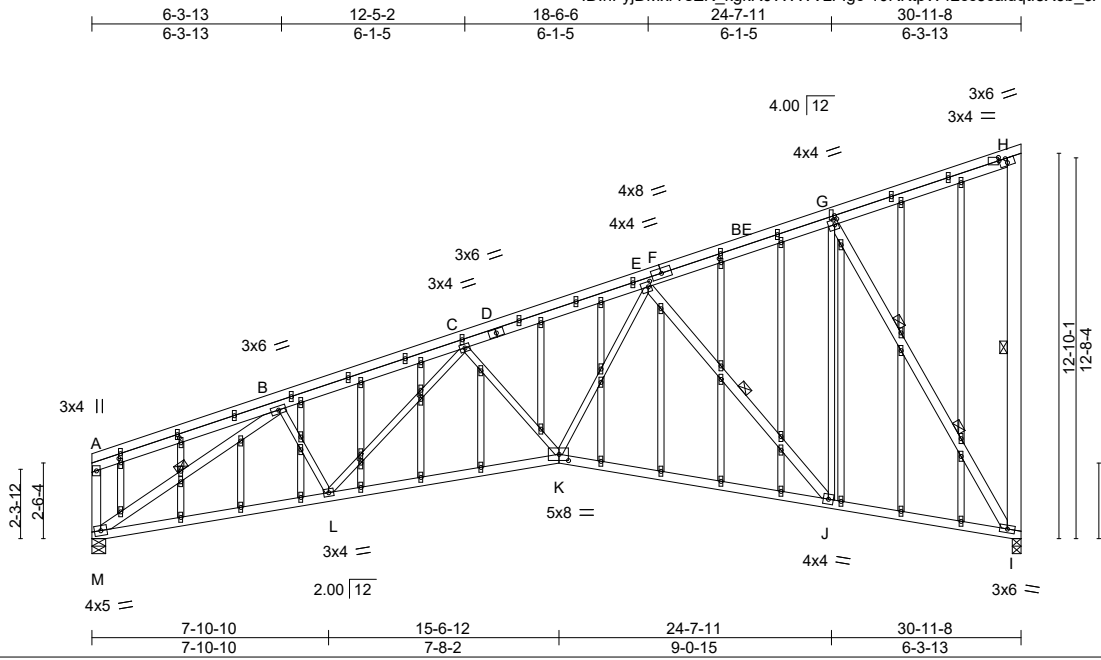

Plate Offsets (X,Y)-- [E:0-1-4,0-2-0], [G:0-1-8,0-2-0], [G:0-1-12,0-0-8], [H:0-2-12,0-0-8], [H:0-3-0,Edge], [K:0-3-12,0-2-8], [AC:0-1-10,0-0-12], [AO:0-1-11,0-0-12], [AR:0-1-11,0-0-12], [BA:0-2-0,0-0-10], [BD:0-1-11,0-0-12]

LOADING (psf)	SPACING-	CSI.	DEFL.	in (loc)	l/defl	L/d	PLATES	GRIP
TCLL 25.0 (Roof Snow=25.0)	2-0-0	TC 0.71	Vert(LL) -0.22	J-K	>999	360	MT20	197/144
TCDL 12.0	Plate Grip DOL 1.15	BC 0.77	Vert(CT) -0.51	J-K	>723	240		
BCLL 0.0 *	Lumber DOL 1.15	WB 0.89	Horz(CT) 0.20	I	n/a	n/a		
BCDL 10.0	Rep Stress Incr YES	Matrix-MS	Wind(LL) 0.10	K-L	>999	240	Weight: 257 lb	FT = 20%
	Code IBC2018/TPI2014							

LUMBER-
 TOP CHORD 2x4 SPF No.2
 BOT CHORD 2x4 SPF No.2
 WEBS 2x3 SPF No.2 *Except*
 H-I: 2x6 SPF No.2, E-J,G-I,A-M,B-M: 2x4 SPF No.2
 OTHERS 2x3 SPF No.2

BRACING-
 TOP CHORD Structural wood sheathing directly applied or 3-1-13 oc purlins, except end verticals.
 BOT CHORD Rigid ceiling directly applied or 9-2-11 oc bracing.
 WEBS 1 Row at midpt H-I, E-J, B-M
 2 Rows at 1/3 pts G-I

REACTIONS. (size) I=0-3-8, M=0-5-8
 Max Horz M=401(LC 7)
 Max Uplift I=-217(LC 10), M=-148(LC 6)
 Max Grav I=1748(LC 16), M=1492(LC 16)

FORCES. (lb) - Max. Comp./Max. Ten. - All forces 250 (lb) or less except when shown.
 TOP CHORD B-C=-2627/313, C-E=-2603/310, E-G=-1041/143, H-I=-301/54
 BOT CHORD L-M=-399/2270, K-L=-358/2655, J-K=-252/1877, I-J=-137/946
 WEBS B-L=0/380, C-L=-282/38, C-K=-347/139, E-K=-133/1270, E-J=-1429/259, G-J=-91/1116, G-I=-1800/238, B-M=-2668/301

- NOTES-**
- 1) Wind: ASCE 7-16; Vult=115mph (3-second gust) Vasd=91mph; TCDL=4.2psf; BCCL=5.0psf; h=30ft; Ke=1.00; Cat. II; Exp B; Enclosed; MWFRS (envelope) gable end zone; cantilever left and right exposed; end vertical left and right exposed; Lumber DOL=1.33 plate grip DOL=1.33
 - 2) Truss designed for wind loads in the plane of the truss only. For studs exposed to wind (normal to the face), see Standard Industry Gable End Details as applicable, or consult qualified building designer as per ANSI/TPI 1.
 - 3) TCLL: ASCE 7-16; Pf=25.0 psf (Lum DOL = 1.15 Plate DOL = 1.15); Is=1.0; Rough Cat B; Partially Exp.; Ce=1.0; Cs=1.00; Ct=1.10
 - 4) Unbalanced snow loads have been considered for this design.
 - 5) All plates are 1.5x4 MT20 unless otherwise indicated.
 - 6) Gable studs spaced at 2-0-0 oc.
 - 7) This truss has been designed for a 10.0 psf bottom chord live load nonconcurrent with any other live loads.
 - 8) * This truss has been designed for a live load of 20.0psf on the bottom chord in all areas where a rectangle 3-6-0 tall by 2-0-0 wide will fit between the bottom chord and any other members.
 - 9) Bearing at joint(s) I, M considers parallel to grain value using ANSI/TPI 1 angle to grain formula. Building designer should verify capacity of bearing surface.
 - 10) Provide mechanical connection (by others) of truss to bearing plate capable of withstanding 217 lb uplift at joint I and 148 lb uplift at joint M.
 - 11) This truss is designed in accordance with the 2018 International Building Code section 2306.1 and referenced standard ANSI/TPI 1.
 - 12) No notches allowed in overhang and 0 from left end and 0 from right end or 12" along rake from scarf, whichever is larger. Minimum 1.5x4 tie plates required at 2-0-0 o.c. maximum between the stacking chords. For edge-wise notching, provide at least one tie plate between each notch.



September 12, 2024

WARNING - Verify design parameters and READ NOTES ON THIS AND INCLUDED MITEK REFERENCE PAGE MII-7473 rev. 6/30/2020 BEFORE USE.
 Design valid for use only with MiTek® connectors. This design is based only upon parameters shown, and is for an individual building component, not a truss system. Before use, the building designer must verify the applicability of design parameters and properly incorporate this design into the overall building design. Bracing indicated is to prevent buckling of individual truss web and/or chord members only. Additional temporary and permanent bracing is always required for stability and to prevent collapse with possible personal injury and property damage. For general guidance regarding the fabrication, storage, delivery, erection and bracing of trusses and truss systems, see **ANSI/TPI1 Quality Criteria, DSB-89 and BCSI Building Component Safety Information** available from Truss Plate Institute, 2670 Crain Highway, Suite 203 Waldorf, MD 20601



Symbols

PLATE LOCATION AND ORIENTATION

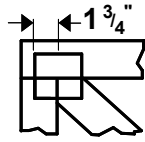

Center plate on joint unless x, y offsets are indicated. Dimensions are in ft-in-sixteenths. Apply plates to both sides of truss and fully embed teeth.

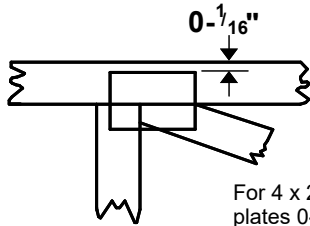

For 4 x 2 orientation, locate plates 0- 1/16" from outside edge of truss.



This symbol indicates the required direction of slots in connector plates.

* Plate location details available in MiTek 20/20 software or upon request.

PLATE SIZE

4 x 4

The first dimension is the plate width measured perpendicular to slots. Second dimension is the length parallel to slots.

LATERAL BRACING LOCATION

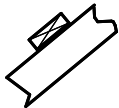

Indicated by symbol shown and/or by text in the bracing section of the output. Use T or I bracing if indicated.

BEARING

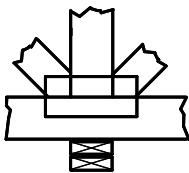

Indicates location where bearings (supports) occur. Icons vary but reaction section indicates joint number where bearings occur. Min size shown is for crushing only.

Industry Standards:

- ANSI/TPI1: National Design Specification for Metal Plate Connected Wood Truss Construction.
- DSB-89: Design Standard for Bracing.
- BCSI: Building Component Safety Information, Guide to Good Practice for Handling, Installing & Bracing of Metal Plate Connected Wood Trusses.

Numbering System

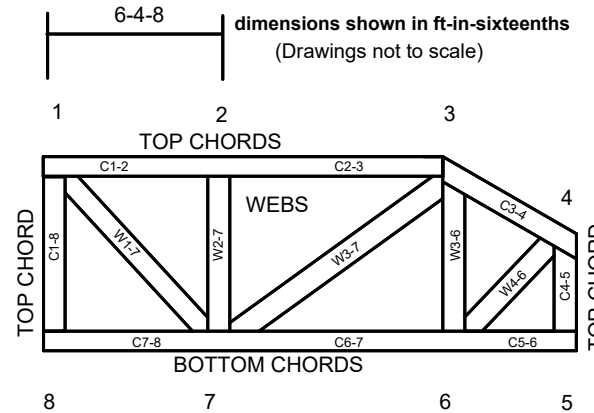

JOINTS ARE GENERALLY NUMBERED/LETTERED CLOCKWISE AROUND THE TRUSS STARTING AT THE JOINT FARTHEST TO THE LEFT.

CHORDS AND WEBS ARE IDENTIFIED BY END JOINT NUMBERS/LETTERS.

PRODUCT CODE APPROVALS

ICC-ES Reports:

ESR-1311, ESR-1352, ESR1988
ER-3907, ESR-2362, ESR-1397, ESR-3282

Trusses are designed for wind loads in the plane of the truss unless otherwise shown.

Lumber design values are in accordance with ANSI/TPI 1 section 6.3 These truss designs rely on lumber values established by others.

© 2012 MiTek® All Rights Reserved



MiTek Engineering Reference Sheet: MII-7473 rev. 6/30/2020

General Safety Notes

Failure to Follow Could Cause Property Damage or Personal Injury

1. Additional stability bracing for truss system, e.g. diagonal or X-bracing, is always required. See BCSI.
2. Truss bracing must be designed by an engineer. For wide truss spacing, individual lateral braces themselves may require bracing, or alternative Tor I bracing should be considered.
3. Never exceed the design loading shown and never stack materials on inadequately braced trusses.
4. Provide copies of this truss design to the building designer, erection supervisor, property owner and all other interested parties.
5. Cut members to bear tightly against each other.
6. Place plates on each face of truss at each joint and embed fully. Knots and wane at joint locations are regulated by ANSI/TPI 1.
7. Design assumes trusses will be suitably protected from the environment in accord with ANSI/TPI 1.
8. Unless otherwise noted, moisture content of lumber shall not exceed 19% at time of fabrication.
9. Unless expressly noted, this design is not applicable for use with fire retardant, preservative treated, or green lumber.
10. Camber is a non-structural consideration and is the responsibility of truss fabricator. General practice is to camber for dead load deflection.
11. Plate type, size, orientation and location dimensions indicated are minimum plating requirements.
12. Lumber used shall be of the species and size, and in all respects, equal to or better than that specified.
13. Top chords must be sheathed or purlins provided at spacing indicated on design.
14. Bottom chords require lateral bracing at 10 ft. spacing, or less, if no ceiling is installed, unless otherwise noted.
15. Connections not shown are the responsibility of others.
16. Do not cut or alter truss member or plate without prior approval of an engineer.
17. Install and load vertically unless indicated otherwise.
18. Use of green or treated lumber may pose unacceptable environmental, health or performance risks. Consult with project engineer before use.
19. Review all portions of this design (front, back, words and pictures) before use. Reviewing pictures alone is not sufficient.
20. Design assumes manufacture in accordance with ANSI/TPI 1 Quality Criteria.
21. The design does not take into account any dynamic or other loads other than those expressly stated.