



(407) 270-6733
 1887 Central Florida Pkwy.
 Orlando- FL. 32837
 www.infinitysignsindustries.com

Project Name: Stewart Title
 Project Owner: Stewart Title
 Scope of Work:
 Scope of work

THE APPROVED PLANS AND ALL DOCUMENTS MUST BE POSTED ON THE JOB FOR ALL INSPECTIONS IN A VISABLE AND READILY ACCESSIBLE LOCATION. FULL SIZED COLOR PLANS ARE REQUIRED TO BE PROVIDED BY THE PERMITTEE ON SITE FOR ALL INSPECTIONS. (MIN. SIZE PLANS TO BE 11" X 17")

Project Address:
 507 31st Ave SW | Puyallup, WA 98373

Permitting jurisdiction:

All drawings are reviewed and approved by

Chad S. Linn, P.E. License No. 57524
 P.O Box 140024 . Orlando, Florida 32814
 Phone: 407 252 6433
 Fax: 407 392 2776
 E. Mail: clinn@linnengineering.com

City of Puyallup
Building APPROVED
 See permit for additional requirements.
 DLeahy
 01/18/2022
 2:28:32 PM



PROJECT SCHEDULE

| Description | QTY | PG |
|-----------------------------------|------------|----------|
| Channel Letters on a Raceway | Two (02) | A.0-A.4 |
| Monument Sign, new aluminum faces | Four (04) | B.0- B.1 |
| White Vinyl Decals | Three (03) | C.0- C.2 |

SHEETS INDEX

| Sheet Title | PG |
|-----------------------------------|-------|
| Site Survey | 2-3 |
| Channel Letters (Option 1) | 4-8 |
| Monument Sign, new aluminum faces | 9-10 |
| Vinyl Decals | 11-13 |

Received Development
 Services January 11,
 2022 CITY OF
 PUYALLUP

Stewart Title

507 31st Ave SW | Puyallup, WA 98373

All drawings and documents appearing hereign are the property of Infinity Signs & Graphix LLC and may not be used, duplicated or disclosed without written consent from Infinity Signs & Graphix LLC. All Rights Reserved.

PLEASE REVIEW THIS PROOF CAREFULLY

We do our best to make sure things are correctly, but is your responsibility to review all spelling and content for accuracy. Infinity Signs & Graphix will not be responsible for any errors in spelling, accurracy, or layout after a proof has been approved.

Colors on finished product may vary slightly from electronic proof.

Location Map

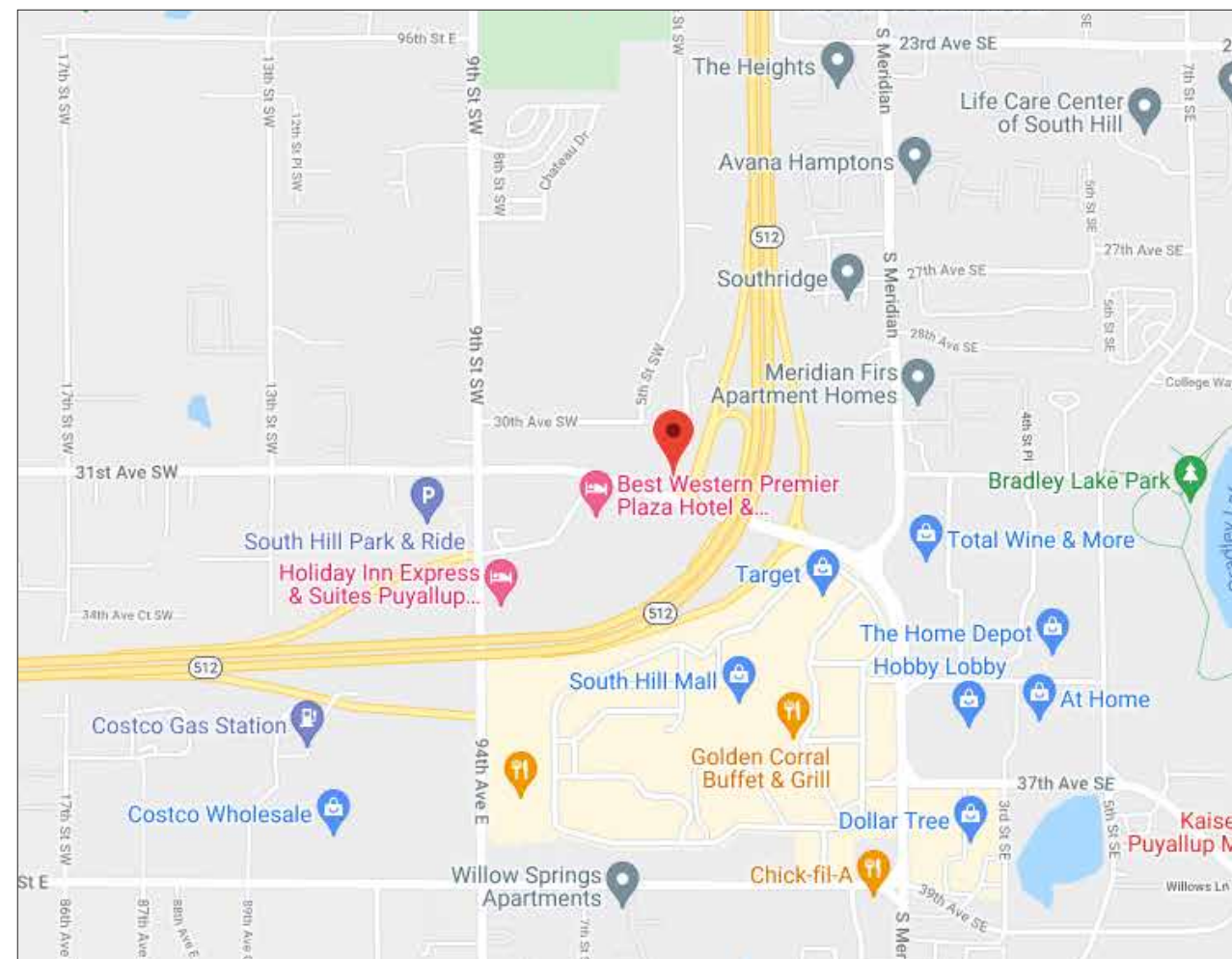

| | | |
|--------------------|----------------------|--|
| Wind Speed | 140 mph | All Wind Loads Meet 7th edition 2020 Florida Building code |
| Mean Height | 60 ft | |
| Wind Code | ASCE 7-10 Exposure C | Risk Category II |
| Wind Pressure (WP) | 48.19 psf | |
| GCP = | 1.40 | Total Pressure = WP*SF 67.47 psf |

Quality Control and UL certification
 All products are subject to quality control inspection prior to leaving our facility.



APPROVED PLAN
 CITY OF PUYALLUP
 PLANNING DIVISION

APPROVED BY: RNBrown

DATE: 02/03/2022

CASE NO.: PRSG2022003

CONDITIONS:

City of Puyallup
 Development & Permitting Services
ISSUED PERMIT

| | |
|-------------|--------------|
| Building | Planning |
| Engineering | Public Works |
| Fire | Traffic |

Project Number

210174

Account Manager

Sal Kalai

Date Started

11/19/2021

Drawing approval date

Processing

Project Manager

Sal Kalai

Designer

Luis Rojas

Drawing approved by

Processing

Number of revisions

Rev 04- 12/10/2021

Site Survey

(407) 270-6733
 1887 Central Florida Pkwy.
 Orlando- FL. 32837
 www.infinitysignsindustries.com

Project Name: Stewart Title
 Project Owner: Stewart Title
 Scope of Work:
 Scope of work

Project Address:
 507 31st Ave SW | Puyallup, WA 98373

Permitting jurisdiction:

All drawings are reviewed and approved by

Chad S. Linn, P.E. License No. 57524
 P.O Box 140024 . Orlando, Florida 32814
 Phone: 407 252 6433
 Fax: 407 392 2776
 E. Mail: clinn@linnengineering.com

Overall cabinet size:
 192.25''(W) x 24''(H)

Panel size: 192''(W) x 23.75''(H)
 V.O.: 189.25''(W) x 21''(H)

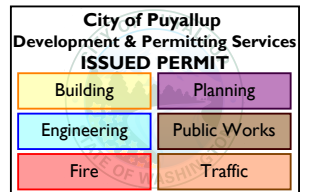

| | |
|-----------------------|--------------------|
| Project Number | 210174 |
| Account Manager | Sal Kalai |
| Date Started | 11/19/2021 |
| Drawing approval date | Processing |
| Project Manager | Sal Kalai |
| Designer | Luis Rojas |
| Drawing approved by | Processing |
| Number of revisions | Rev 04- 12/10/2021 |

Wind Speed 140 mph
 Mean Height 60 ft
 All Wind Loads Meet 7th edition 2020 Florida Building code

Wind Code ASCE 7-10 Exposure C Risk Category II
 Wind Pressure (WP) 48.19 psf
 GCp = 1.40 Total Pressure = WP*SF 67.47 psf

Quality Control and UL certification
 All products are subject to quality control inspection prior to leaving our facility.



Monument Sign - Face Replacement | Site Survey

(407) 270-6733
 1887 Central Florida Pkwy.
 Orlando- FL. 32837
 www.infinitysignsindustries.com

Project Name: Stewart Title
 Project Owner: Stewart Title
 Scope of Work:
 Scope of work

Project Address:
 507 31st Ave SW | Puyallup, WA 98373

Permitting jurisdiction:

All drawings are reviewed and approved by

Chad S. Linn, P.E. License No. 57524
 P.O Box 140024 . Orlando, Florida 32814
 Phone: 407 252 6433
 Fax: 407 392 2776
 E. Mail: clinn@linnengineering.com

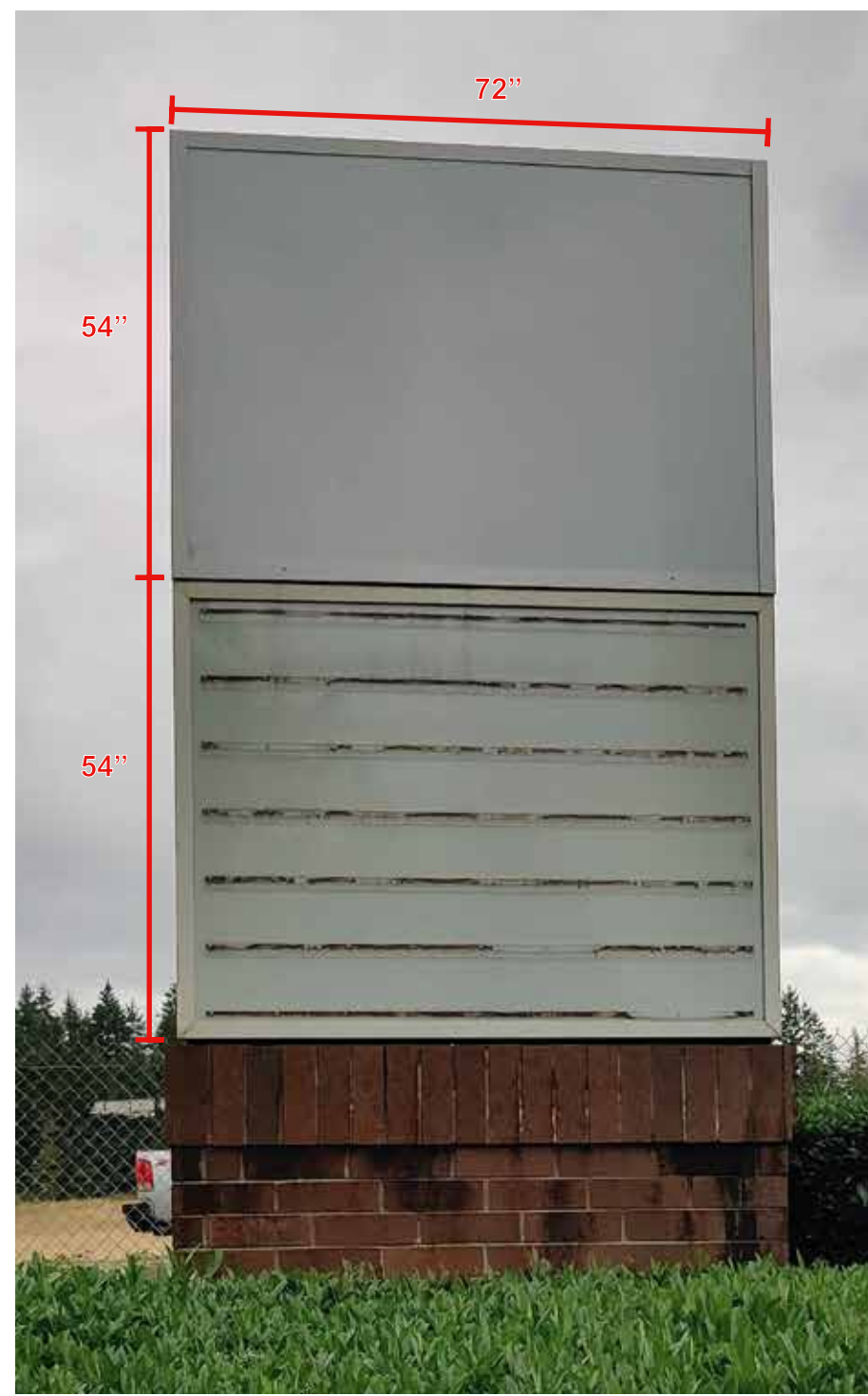

Overall cabinet size(2): 72”(W) x 54”(H)
Panel size: 71.75”(W) x 53.75”(H)
V.O.: 68”(W) x 50”(H)

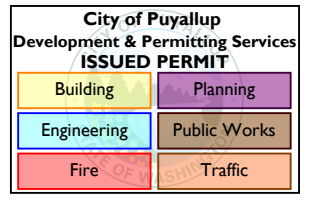

| | |
|-----------------------|--------------------|
| Project Number | 210174 |
| Account Manager | Sal Kalai |
| Date Started | 11/19/2021 |
| Drawing approval date | Processing |
| Project Manager | Sal Kalai |
| Designer | Luis Rojas |
| Drawing approved by | Processing |
| Number of revisions | Rev 04- 12/10/2021 |

Wind Speed 140 mph
 Mean Height 60 ft
 All Wind Loads Meet 7th edition 2020 Florida Building code

Wind Code ASCE 7-10 Exposure C Risk Category II
 Wind Pressure (WP) 48.19 psf
 GCp = 1.40 Total Pressure = WP*SF 67.47 psf

Quality Control and UL certification
 All products are subject to quality control inspection prior to leaving our facility.



Channel Letters on a Raceway | Size & Design

(407) 270-6733
 1887 Central Florida Pkwy.
 Orlando- FL. 32837
 www.infinitysignsindustries.com

Project Name: Stewart Title
 Project Owner: Stewart Title
 Scope of Work:
 Scope of work

Project Address:
 507 31st Ave SW | Puyallup, WA 98373

Permitting jurisdiction:

All drawings are reviewed and approved by

Chad S. Linn, P.E. License No. 57524
 P.O Box 140024 . Orlando, Florida 32814
 Phone: 407 252 6433
 Fax: 407 392 2776
 E. Mail: clinn@linnengineering.com

39.35 SQF each set

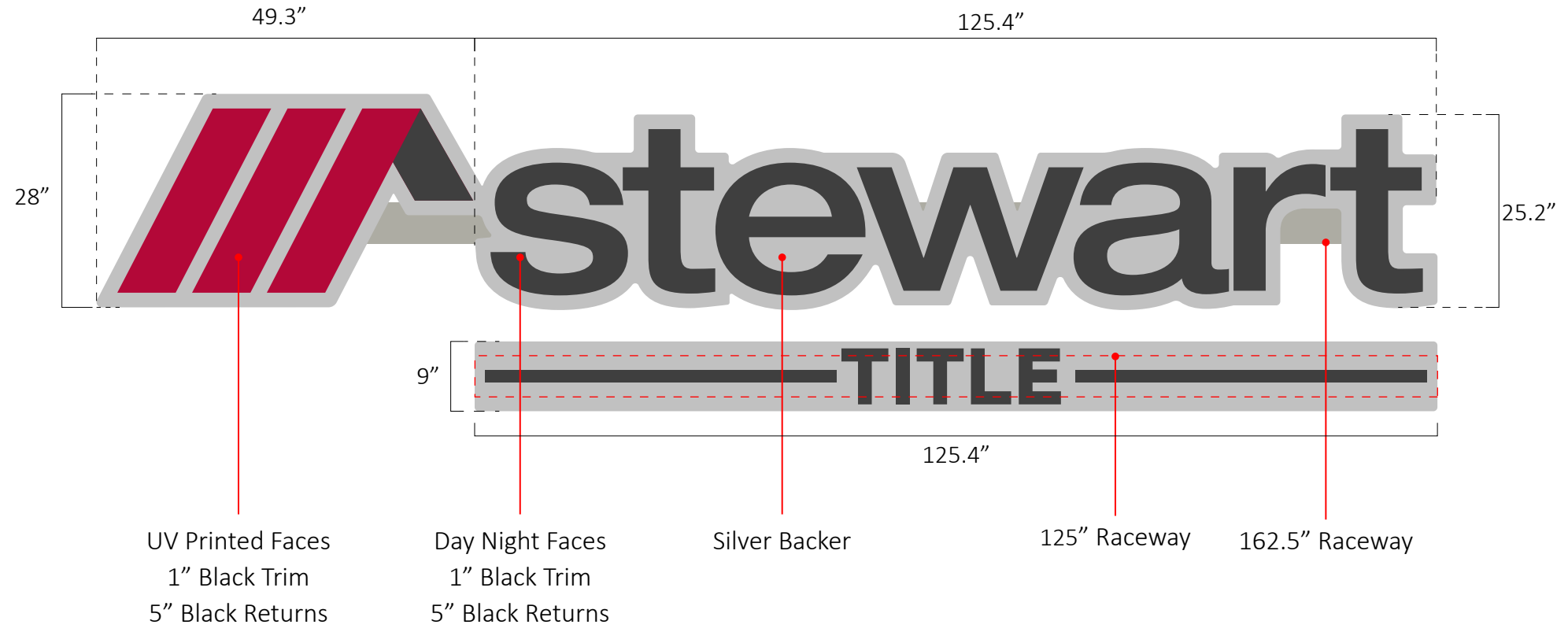
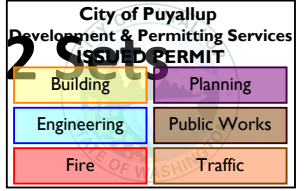

Project Number
210174

Account Manager
Sal Kalai

Date Started
11/19/2021

Drawing approval date
Processing

Project Manager
Sal Kalai

Designer
Luis Rojas

Drawing approved by
Processing

Number of revisions
Rev 04- 12/10/2021

Wind Speed 140 mph
Mean Height 60 ft
All Wind Loads Meet 7th edition 2020 Florida Building code

Wind Code ASCE 7-10 Exposure C Risk Category II
Wind Pressure (WP) 48.19 psf
GCp = 1.40 Total Pressure = WP*SF 67.47 psf

Quality Control and UL certification
All products are subject to quality control inspection prior to leaving our facility.



File#E502940

City of Puyallup
Development & Permitting Services
ISSUED PERMIT

| | |
|-------------|--------------|
| Building | Planning |
| Engineering | Public Works |
| Fire | Traffic |

Channel Letters on a Raceway | Electrical Diagram



(407) 270-6733
1887 Central Florida Pkwy.
Orlando- FL. 32837
www.infinitysignsindustries.com

Project Name: Stewart Title
Project Owner: Stewart Title
Scope of Work:
Scope of work

Project Address:
507 31st Ave SW | Puyallup, WA 98373
Permitting jurisdiction:

All drawings are reviewed and approved by
Chad S. Linn, P.E. License No. 57524
P.O Box 140024 . Orlando, Florida 32814
Phone: 407 252 6433
Fax: 407 392 2776
E. Mail: clinn@linnengineering.com

Hardware

-  1/4"x1 3/4" Concrete Anchors Tapcon Screws
-  5/16 x 1-1/2 Aluminum self tapping hex head screw

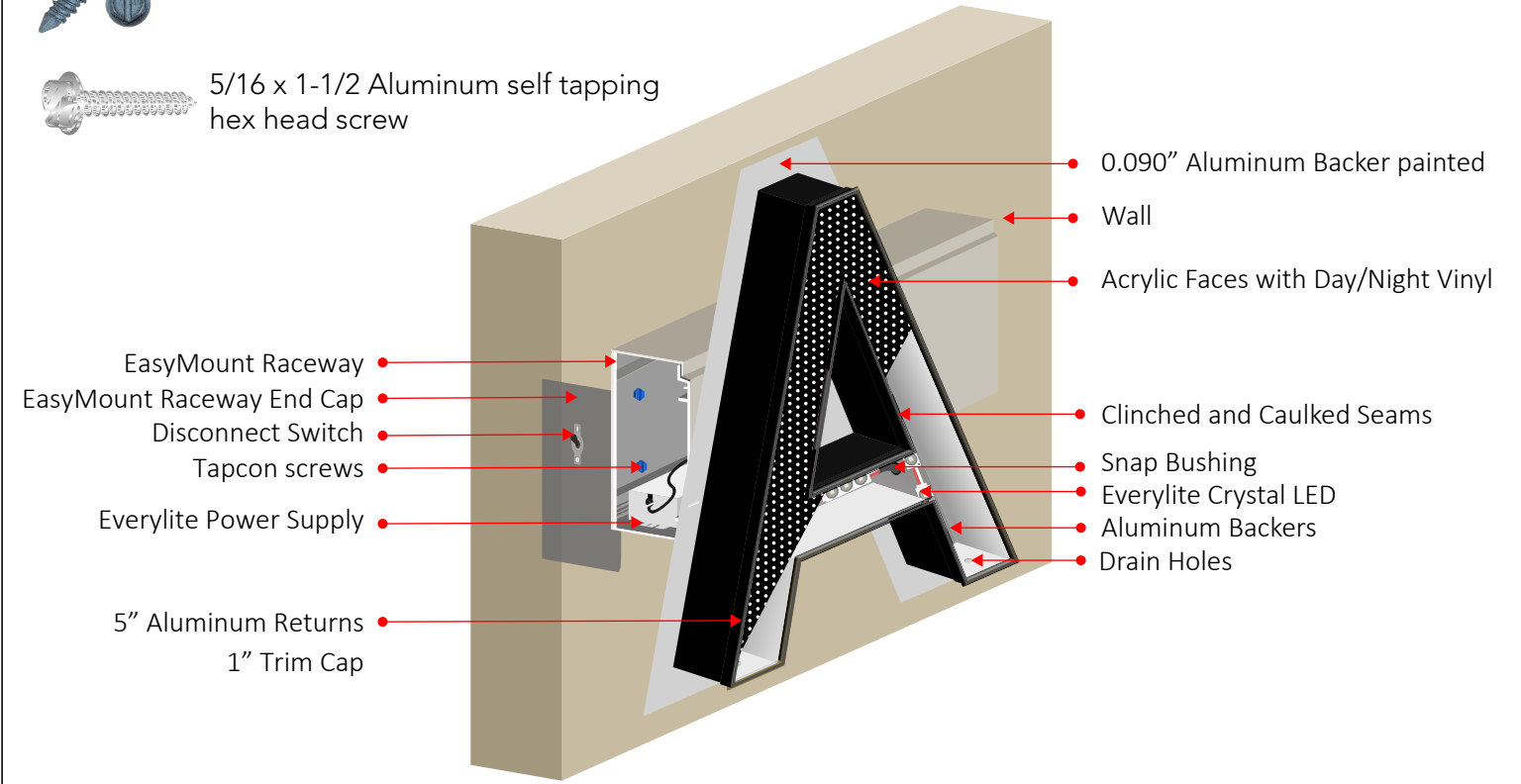

SECTION DETAILS - LETTERS

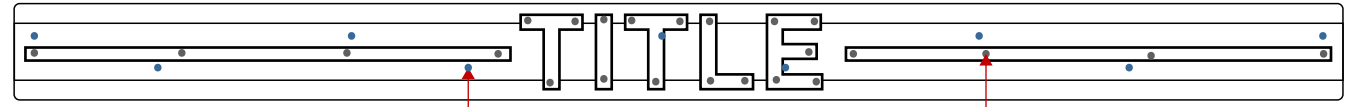
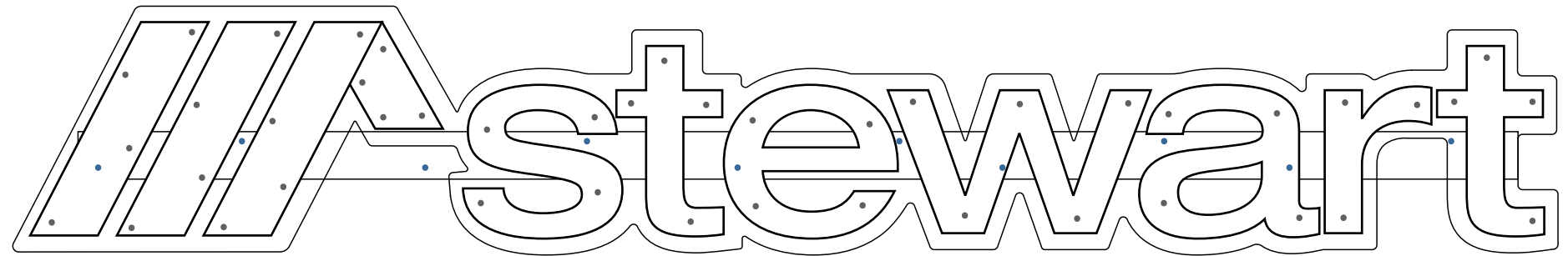
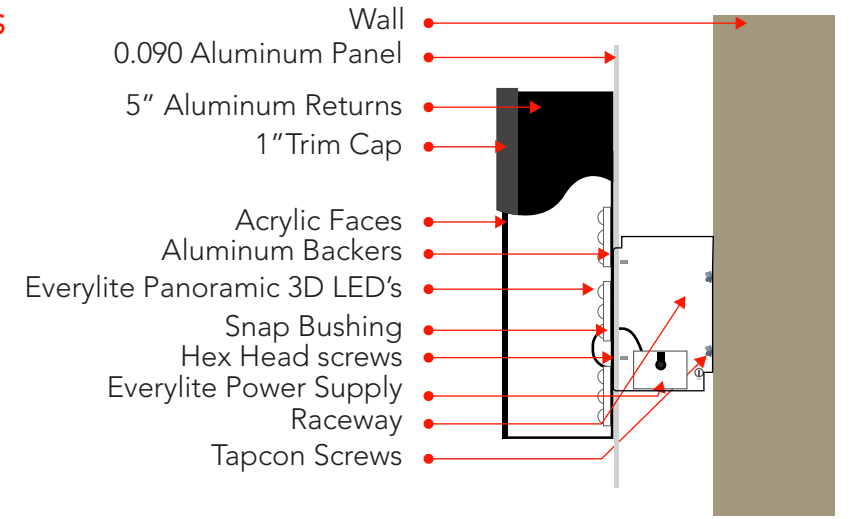

| Material | Color |
|---------------------------------|----------------------------|
| Back: .063 Aluminium | Mill |
| Return: .5" deep .040 Aluminium | Black |
| Face: 1/8" Acrylic | White Standard w/ UV Print |
| Trim cap: 1" Jewlite | Black |
| | |
| | |

Tapcon screws to attach raceways to the wall (every two (02) feet)

Hex head screws to attach letters to the backer and Backer to the raceways (2 to 5 on each letter depending on the letter size)

| | |
|-----------------------|--------------------|
| Project Number | 210174 |
| Account Manager | Sal Kalai |
| Date Started | 11/19/2021 |
| Drawing approval date | Processing |
| Project Manager | Sal Kalai |
| Designer | Luis Rojas |
| Drawing approved by | Processing |
| Number of revisions | Rev 04- 12/10/2021 |

Wind Speed 140 mph
 Mean Height 60 ft
 All Wind Loads Meet 7th edition 2020 Florida Building code

Wind Code ASCE 7-10 Exposure C Risk Category II
 Wind Pressure (WP) 48.19 psf
 GCp = 1.40 Total Pressure = WP*SF 67.47 psf

Quality Control and UL certification
 All products are subject to quality control inspection prior to leaving our facility.



Channel Letters on a Raceway | Attachment

(407) 270-6733
 1887 Central Florida Pkwy.
 Orlando- FL. 32837
 www.infinitysignsindustries.com

Project Name: Stewart Title
 Project Owner: Stewart Title
 Scope of Work:
 Scope of work

Project Address:
 507 31st Ave SW | Puyallup, WA 98373

Permitting jurisdiction:

All drawings are reviewed and approved by

Chad S. Linn, P.E. License No. 57524
 P.O. Box 140024 . Orlando, Florida 32814
 Phone: 407 252 6433
 Fax: 407 392 2776
 E. Mail: clinn@linnengineering.com

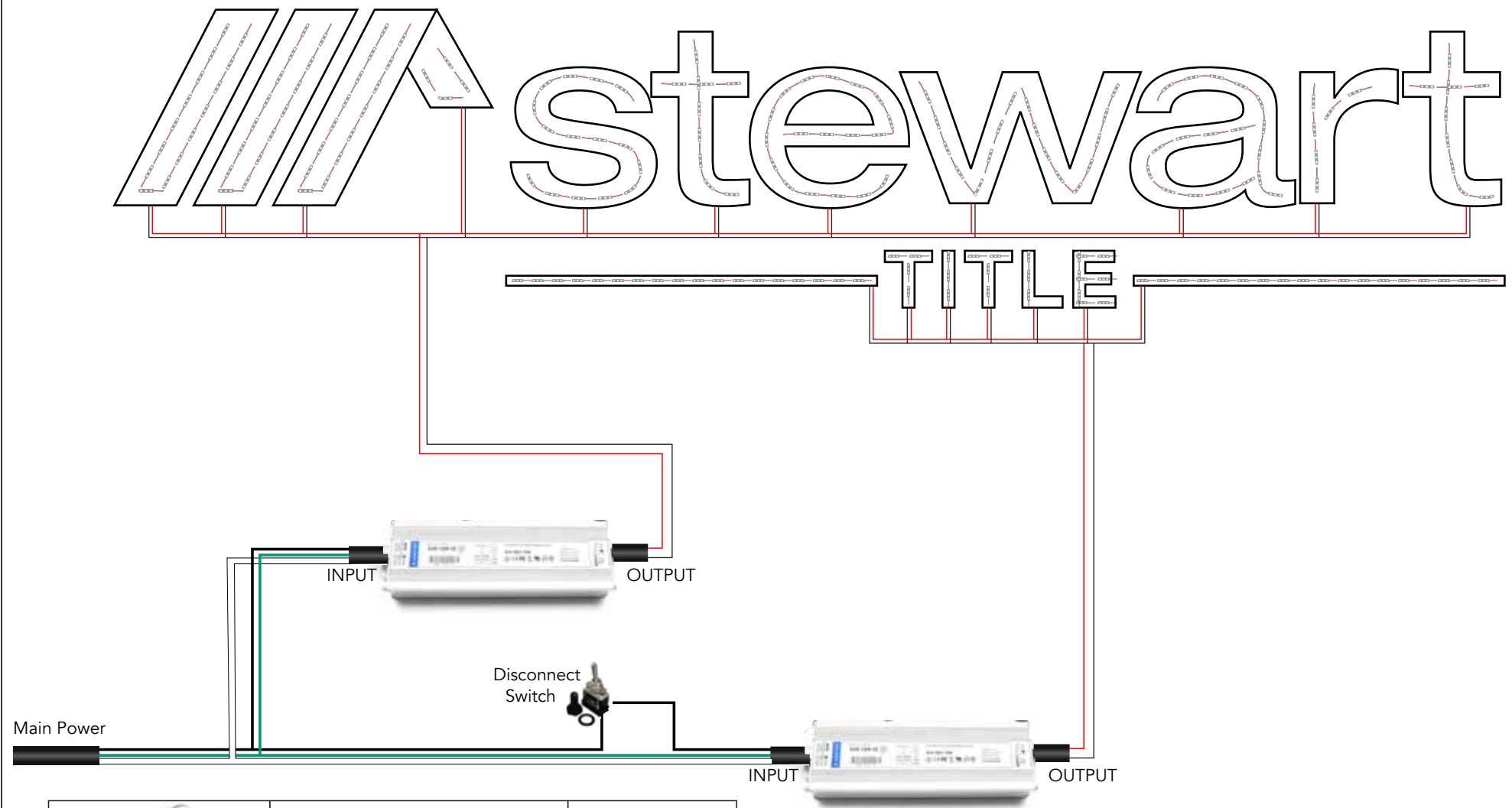
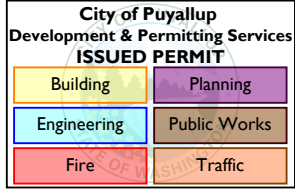

| | | | |
|--|---|---|---|
|  |  | Input: 110V 180 watts 1.5 Amps Output: 12V |  |
| Panoramic 3D Red / white color 9000K module | Everylite Class 2 Power Supply | (x2) | Disconnect Switch |

Notes: Electrical

Panoramic 3D white color 9000K module / Red Color
 Everylite Class 2 Power Supply
 All electrical components are UL Rated.

Wiring Diagram
 120 v

Wiring Diagram
 12 v

| | |
|-----------------------|--------------------|
| Project Number | 210174 |
| Account Manager | Sal Kalai |
| Date Started | 11/19/2021 |
| Drawing approval date | Processing |
| Project Manager | Sal Kalai |
| Designer | Luis Rojas |
| Drawing approved by | Processing |
| Number of revisions | Rev 04- 12/10/2021 |

Channel Letters on a Raceway | 3D Renders

(407) 270-6733
1887 Central Florida Pkwy.
Orlando- FL. 32837
www.infinitysignsindustries.com

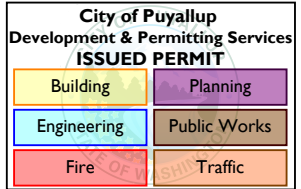

Project Name: Stewart Title
Project Owner: Stewart Title
Scope of Work:
Scope of work

Project Address:
507 31st Ave SW | Puyallup, WA 98373

Permitting jurisdiction:

All drawings are reviewed and approved by

Chad S. Linn, P.E. License No. 57524
P.O Box 140024 . Orlando, Florida 32814
Phone: 407 252 6433
Fax: 407 392 2776
E. Mail: clinn@linnengineering.com



Project Number
210174

Account Manager
Sal Kalai

Date Started
11/19/2021

Drawing approval date
Processing

Project Manager
Sal Kalai

Designer
Luis Rojas

Drawing approved by
Processing

Number of revisions
Rev 04- 12/10/2021

Wind Speed 140 mph
 Mean Height 60 ft
 All Wind Loads Meet 7th edition 2020 Florida Building code

Wind Code ASCE 7-10 Exposure C Risk Category II
 Wind Pressure (WP) 48.19 psf
 GCp = 1.40 Total Pressure = WP*SF 67.47 psf

Quality Control and UL certification
 All products are subject to quality control inspection prior to leaving our facility.



Channel Letters on a Raceway | Mockup

(407) 270-6733
 1887 Central Florida Pkwy.
 Orlando- FL. 32837
 www.infinitysignsindustries.com

| City of Puyallup Development & Permitting Services ISSUED PERMIT | |
|--|--------------|
| Building | Planning |
| Engineering | Public Works |
| Fire | Traffic |

Project Name: Stewart Title
 Project Owner: Stewart Title
 Scope of Work:
 Scope of work

Project Address:
 507 31st Ave SW | Puyallup, WA 98373

Permitting jurisdiction:

All drawings are reviewed and approved by

Chad S. Linn, P.E. License No. 57524
 P.O Box 140024 . Orlando, Florida 32814
 Phone: 407 252 6433
 Fax: 407 392 2776
 E. Mail: clinn@linnengineering.com



Project Number
 210174

Account Manager
 Sal Kalai

Date Started
 11/19/2021

Drawing approval date
 Processing

Project Manager
 Sal Kalai

Designer
 Luis Rojas

Drawing approved by
 Processing

Number of revisions
 Rev 04- 12/10/2021

Wind Speed 140 mph
 Mean Height 60 ft
 All Wind Loads Meet 7th edition 2020 Florida Building code

Wind Code ASCE 7-10 Exposure C Risk Category II
 Wind Pressure (WP) 48.19 psf
 GCp = 1.40 Total Pressure = WP*SF 67.47 psf

Quality Control and UL certification
 All products are subject to quality control inspection prior to leaving our facility.



Monument Sign - Face Replacement | Size and Design

(407) 270-6733
 1887 Central Florida Pkwy.
 Orlando- FL. 32837
 www.infinitysignsindustries.com

Project Name: Stewart Title
 Project Owner: Stewart Title
 Scope of Work:
 Scope of work

Project Address:
 507 31st Ave SW | Puyallup, WA 98373

Permitting jurisdiction:

All drawings are reviewed and approved by

Chad S. Linn, P.E. License No. 57524
 P.O Box 140024 . Orlando, Florida 32814
 Phone: 407 252 6433
 Fax: 407 392 2776
 E. Mail: clinn@linnengineering.com

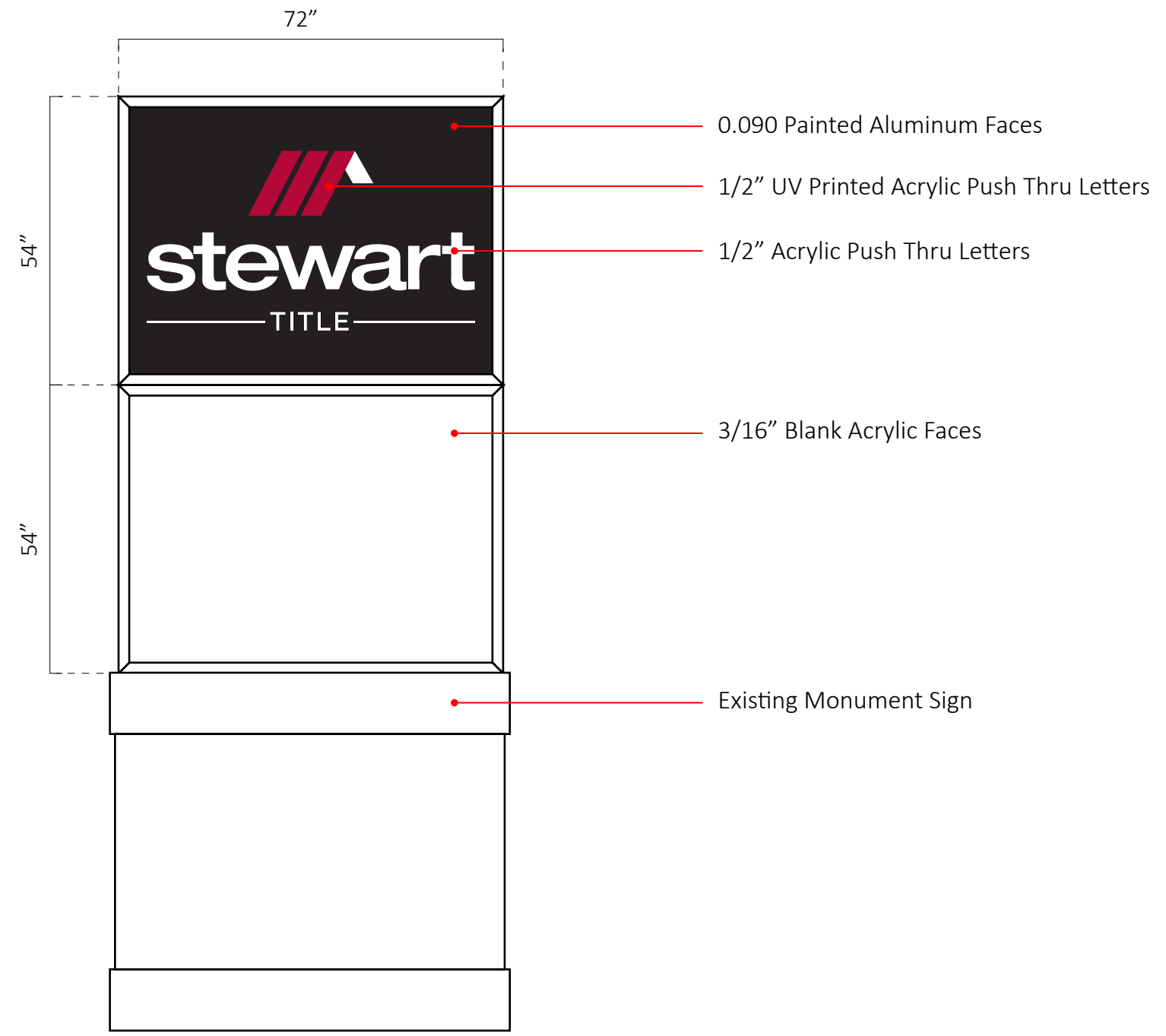
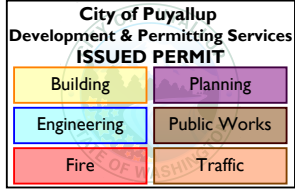

| | |
|-----------------------|--------------------|
| Project Number | 210174 |
| Account Manager | Sal Kalai |
| Date Started | 11/19/2021 |
| Drawing approval date | Processing |
| Project Manager | Sal Kalai |
| Designer | Luis Rojas |
| Drawing approved by | Processing |
| Number of revisions | Rev 04- 12/10/2021 |

Wind Speed 140 mph
 Mean Height 60 ft
 All Wind Loads Meet 7th edition 2020 Florida Building code

Wind Code ASCE 7-10 Exposure C Risk Category II
 Wind Pressure (WP) 48.19 psf
 GCp = 1.40 Total Pressure = WP*SF 67.47 psf

Quality Control and UL certification
 All products are subject to quality control inspection prior to leaving our facility.



File#E502940

City of Puyallup
 Development & Permitting Services
ISSUED PERMIT

| | |
|-------------|--------------|
| Building | Planning |
| Engineering | Public Works |
| Fire | Traffic |

Monument Sign - Face Replacement | 3D Renders

(407) 270-6733
 1887 Central Florida Pkwy.
 Orlando- FL. 32837
 www.infinitysignsindustries.com

Project Name: Stewart Title
 Project Owner: Stewart Title
 Scope of Work:
 Scope of work

Project Address:
 507 31st Ave SW | Puyallup, WA 98373

Permitting jurisdiction:

All drawings are reviewed and approved by

Chad S. Linn, P.E. License No. 57524
 P.O Box 140024 . Orlando, Florida 32814
 Phone: 407 252 6433
 Fax: 407 392 2776
 E. Mail: clinn@linnengineering.com



| | |
|-----------------------|--------------------|
| Project Number | 210174 |
| Account Manager | Sal Kalai |
| Date Started | 11/19/2021 |
| Drawing approval date | Processing |
| Project Manager | Sal Kalai |
| Designer | Luis Rojas |
| Drawing approved by | Processing |
| Number of revisions | Rev 04- 12/10/2021 |

Wind Speed 140 mph
 Mean Height 60 ft
 All Wind Loads Meet 7th edition 2020 Florida Building code

Wind Code ASCE 7-10 Exposure C Risk Category II
 Wind Pressure (WP) 48.19 psf
 GCp = 1.40 Total Pressure = WP*SF 67.47 psf

Quality Control and UL certification
 All products are subject to quality control inspection prior to leaving our facility.



Vinyl Decal | Size and Design Set 1

(407) 270-6733
 1887 Central Florida Pkwy.
 Orlando- FL. 32837
 www.infinitysignsindustries.com

Project Name: Stewart Title
 Project Owner: Stewart Title
 Scope of Work:
 Scope of work

Project Address:
 507 31st Ave SW | Puyallup, WA 98373

Permitting jurisdiction:

All drawings are reviewed and approved by

Chad S. Linn, P.E. License No. 57524
 P.O Box 140024 . Orlando, Florida 32814
 Phone: 407 252 6433
 Fax: 407 392 2776
 E. Mail: clinn@linnengineering.com

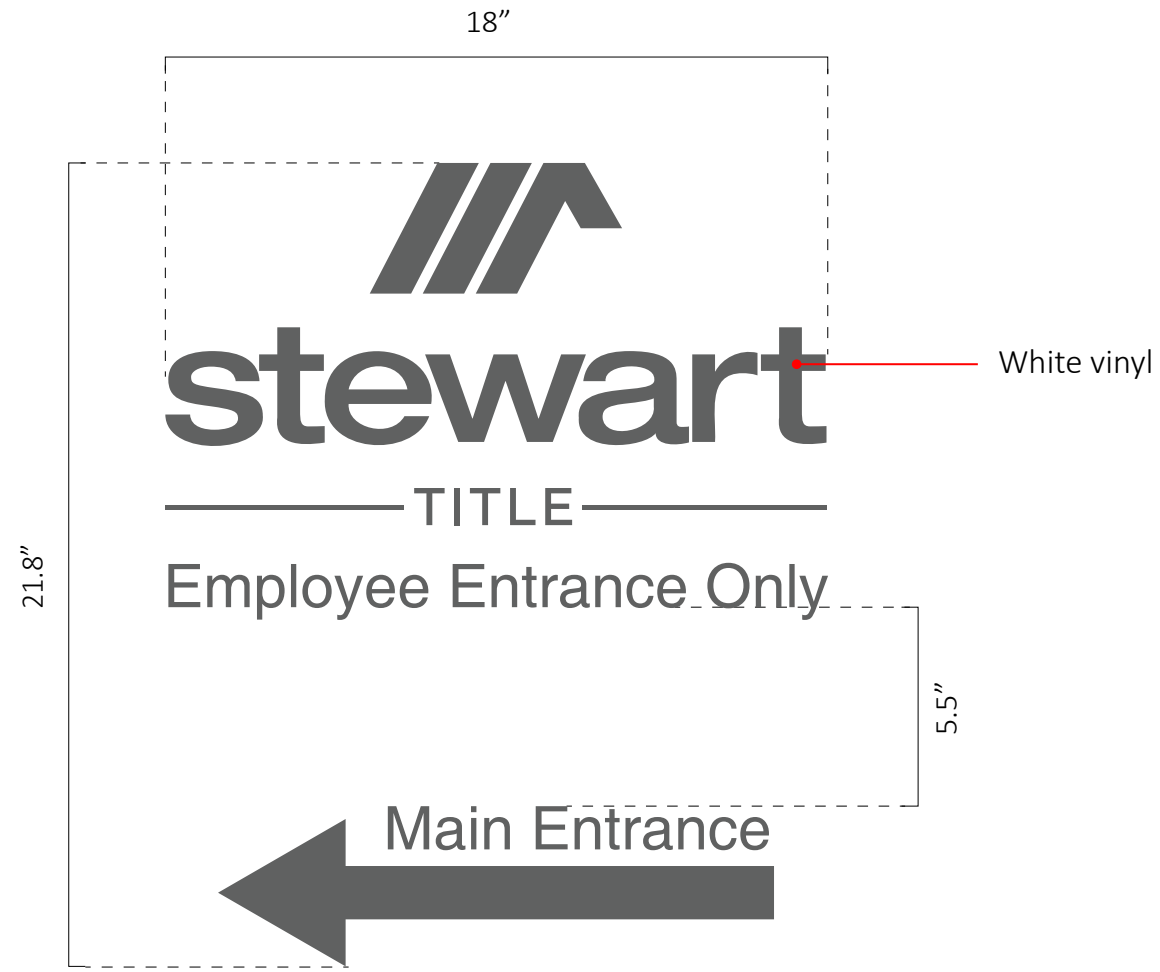
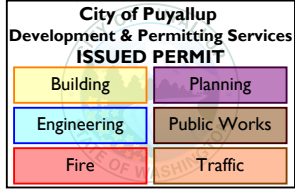

Project Number
 210174

Account Manager
 Sal Kalai

Date Started
 11/19/2021

Drawing approval date
 Processing

Project Manager
 Sal Kalai

Designer
 Luis Rojas

Drawing approved by
 Processing

Number of revisions
 Rev 04- 12/10/2021

Wind Speed 140 mph
 Mean Height 60 ft
 All Wind Loads Meet 7th edition 2020 Florida Building code

Wind Code ASCE 7-10 Exposure C Risk Category II
 Wind Pressure (WP) 48.19 psf
 GCp = 1.40 Total Pressure = WP*SF 67.47 psf

Quality Control and UL certification
 All products are subject to quality control inspection prior to leaving our facility.



Vinyl Decal | Size and Design Set 2

(407) 270-6733
 1887 Central Florida Pkwy.
 Orlando- FL. 32837
 www.infinitysignsindustries.com

Project Name: Stewart Title
 Project Owner: Stewart Title
 Scope of Work:
 Scope of work

Project Address:
 507 31st Ave SW | Puyallup, WA 98373

Permitting jurisdiction:

All drawings are reviewed and approved by

Chad S. Linn, P.E. License No. 57524
 P.O Box 140024 . Orlando, Florida 32814
 Phone: 407 252 6433
 Fax: 407 392 2776
 E. Mail: clinn@linnengineering.com

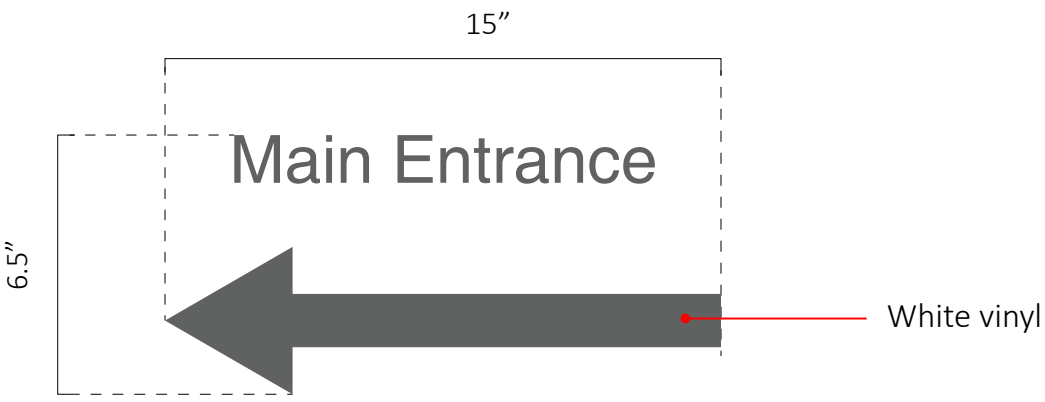
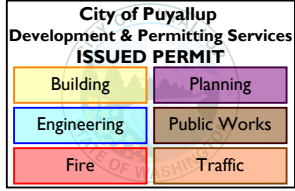

| | |
|-----------------------|--------------------|
| Project Number | 210174 |
| Account Manager | Sal Kalai |
| Date Started | 11/19/2021 |
| Drawing approval date | Processing |
| Project Manager | Sal Kalai |
| Designer | Luis Rojas |
| Drawing approved by | Processing |
| Number of revisions | Rev 04- 12/10/2021 |

Wind Speed 140 mph
 Mean Height 60 ft
 All Wind Loads Meet 7th edition 2020 Florida Building code

Wind Code ASCE 7-10 Exposure C Risk Category II
 Wind Pressure (WP) 48.19 psf
 GCp = 1.40 Total Pressure = WP*SF 67.47 psf

Quality Control and UL certification
 All products are subject to quality control inspection prior to leaving our facility.



Vinyl Decal | Size and Design

Set 3

(407) 270-6733
 1887 Central Florida Pkwy.
 Orlando- FL. 32837
 www.infinitysignsindustries.com

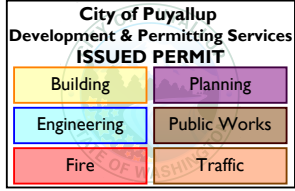

Project Name: Stewart Title
 Project Owner: Stewart Title
 Scope of Work:
 Scope of work

Project Address:
 507 31st Ave SW | Puyallup, WA 98373

Permitting jurisdiction:

All drawings are reviewed and approved by

Chad S. Linn, P.E. License No. 57524
 P.O Box 140024 . Orlando, Florida 32814
 Phone: 407 252 6433
 Fax: 407 392 2776
 E. Mail: clinn@linnengineering.com



| | |
|-----------------------|--------------------|
| Project Number | 210174 |
| Account Manager | Sal Kalai |
| Date Started | 11/19/2021 |
| Drawing approval date | Processing |
| Project Manager | Sal Kalai |
| Designer | Luis Rojas |
| Drawing approved by | Processing |
| Number of revisions | Rev 04- 12/10/2021 |