

**City of Puyallup
Site License Addendum**

Company shall apply to the City for approval of this Site License Addendum by filling out the below form and submitting the form to the City for approval with the applicable Administrative Fee. For each Small Cell Facility, the Company shall fill out a Site License Addendum.

This Site License Addendum (“Addendum”), made this 30th day of November, 2021 (the “Site License Addendum Effective Date”) between the City of Puyallup, hereinafter designated the “City” and New Cingular Wireless PCS, LLC, with its principal offices at 1025 Lenox Park Blvd NE, 3rd Floor, Atlanta, GA 30319 hereinafter designated “Company”:

1. Addendum. This is a Site License Addendum as referenced in that certain Master License Agreement between The City and Company dated August 14th, 2021 ("Agreement"). All of the terms and conditions of the Agreement are incorporated hereby by reference and made a part hereof without the necessity of repeating or attaching the Agreement. In the event of a contradiction, modification or inconsistency between the terms of the Agreement and this Addendum, the terms of this Addendum shall govern. Capitalized terms used in this Addendum shall have the same meaning described for them in the Agreement unless otherwise indicated herein.

2. Project Location. Attachment 1 identifies the physical location of the City Pole on which the Site Equipment shall be attached.

3. Project Description. Attachment 2 identifies the Site Equipment to be installed on the City Poles and shall include the construction details (e.g. electrical and fiber connections, antennas, radios and accessory components). Company shall provide photo simulations of such Site Equipment attached to the City Poles and a load bearing study. The photo simulations shall include photos indicating the existing City Pole without the Site Equipment and with the proposed Site Equipment attached. If there are any accessory components, for example conduit holding backhaul or electrical, such accessory components shall be depicted in the photo simulations. If City Pole re-enforcement or replacement is necessary, include engineering design and specification drawings demonstrating the proposed alteration to the City Pole. All engineering drawings submitted must be completed and stamped by a registered qualified engineer licensed in Washington State.

4. Frequencies. Company is authorized by the FCC to use the following frequencies:

5. Backhaul. Backhaul services shall be provided to the Site Equipment as follows:
 underground fiber aboveground fiber microwave other _____

and from the following entity: _____ TBD; unknown at time of application _____.

6. Usage of City-Owned Conduit. Does the Company request usage of City’s streetlight conduit?
Note, usage will depend on whether the City has additional space in its conduit and will require a separate conduit rental fee.
 Yes No

7. Term. The term of this Addendum shall run concurrently with the Agreement and shall

terminate upon the Agreement termination unless earlier terminated by a party consistent with the Agreement.

8. Commencement Date. Company shall notify the City upon the installation and operation of its Site Equipment on the City Pole.

9. Fees. The Rent and Administrative Fee for the Site Equipment installed pursuant to this Addendum shall be in accordance with Section 6 of the Agreement.

10. Counterparts. This Site License Addendum may be signed in counterparts, each of which shall be deemed an original, but all of which will constitute one and the same document.

11. Authority. Each individual executing this Site License Addendum represents and warrants that such individual is duly authorized to execute and delivery this Site License Addendum on behalf of the party it represents.

12. Carrier. The following third-party wireless carrier's equipment will be located on this City Pole: _____ or same as Company.

13. Acknowledgment. Company acknowledges that (i) this Site License Addendum is only effective upon the signatures of both parties and (ii) Company shall not have the right to install its Site Equipment on the City Poles until it has received Government Approvals and complied with the requirements (including any insurance or bonding requirements) of such Government Approvals.

EXECUTED to be effective as of the Site License Addendum Effective Date.

CITY OF PUYALLUP:

COMPANY

By: _____
Name: _____
Title: _____

By: _____
Name: _____
Title: _____

Exhibits:

Attachment 1 – Physical Location of City Pole

Attachment 2 – Photo Simulations, Description of Site Equipment and Load Bearing Study

Attachment 1
Physical Location of City Pole



INDEX TO SHEETS	
SHEET	TITLE
1	COVER SHEET
2	PUYALLUP GENERAL NOTES
3	GENERAL NOTES CONT.
4	LEGEND & CONTACT INFO
5	RF COMPLIANCE
6	RF COMPLIANCE
7	1A AND BOUNDARY SURVEY
8	PLAN & RESTORATION VIEW
9	TRAFFIC CONTROL PLAN
10	POLE ELEVATIONS
11	POLE ELEVATIONS
12	EQUIPMENT DETAILS & PLUMBING DIAGRAM
13	GROUNDING & SIGNAGE DETAILS
14	STANDARD CONSTRUCTION DETAILS
15	STANDARD CONSTRUCTION DETAILS
16	STANDARD CONSTRUCTION DETAILS
17	STANDARD TRAFFIC CONTROL DETAILS
18	PHOTO SIMULATION

AT&T SITE NAME: 27107-WATCM-050-F
PACE #: MRWOR040047
FA #: 14847400
POLE #: T.B.D.
ADDRESS: 709 2ND ST.NW., PUYALLUP, WA 98371
PROPOSED DAS SMALL CELL INSTALLATION

ENGINEER'S ESTIMATE OF MATERIALS	
QUANTITY	ITEM
1	NEW POLE - WESTERN 35.0' CONCEALMENT METAL POLE
1	NEW LUMINEER
1	NEW POLE FOUNDATION
1	GALTRONICS QUASI-OMNI 12-PORT CANISTER ANTENNA
1	NOKIA B25/B66 AIRSCALE MICRO RRH (AHFIB) W/ PSU-1200W-48-X
1	RAYCAP AC DISCONNECT W/ INTEGRATED SURGE PROTECTION
9	LINEAR FEET OF 1-2" PVC SCHEDULE 40 CONDUIT
1	TYPE 2 FIBER JUNCTION BOX

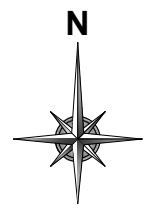

OWNER



DEVELOPER



ENGINEER

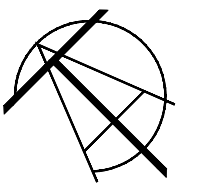

TALMAN CONSULTANTS

CONTRACTOR

LOCATION MAP

PUYALLUP PUBLIC WORKS METAL LIGHT POLE LOCATION FOR NODE EQUIPMENT (EX. LOCATION)

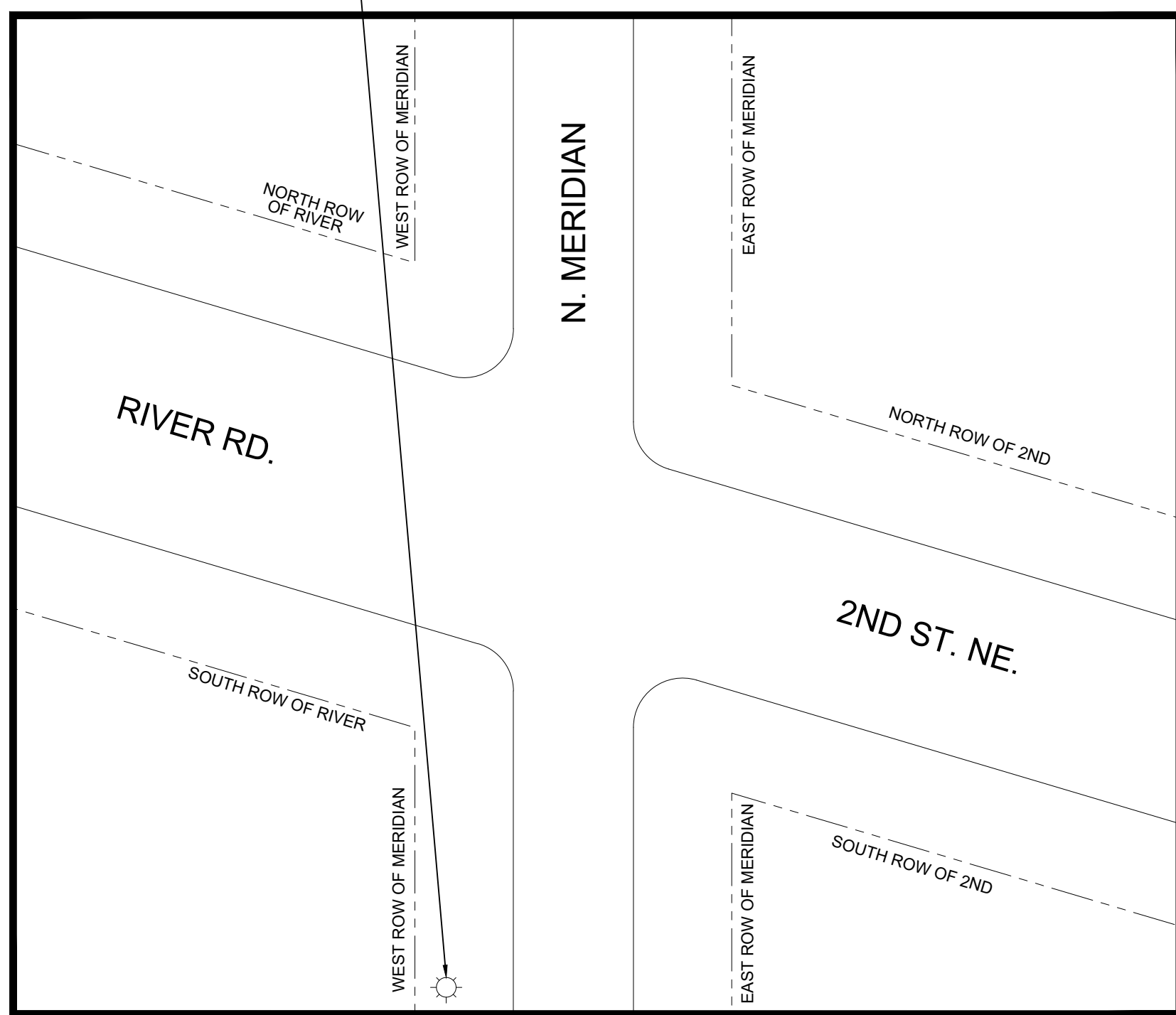

EXISTING POLE ELEVATION - LOOKING NORTHWEST

PUYALLUP PUBLIC WORKS METAL LIGHT POLE TO BE REPLACED



AREA MAP

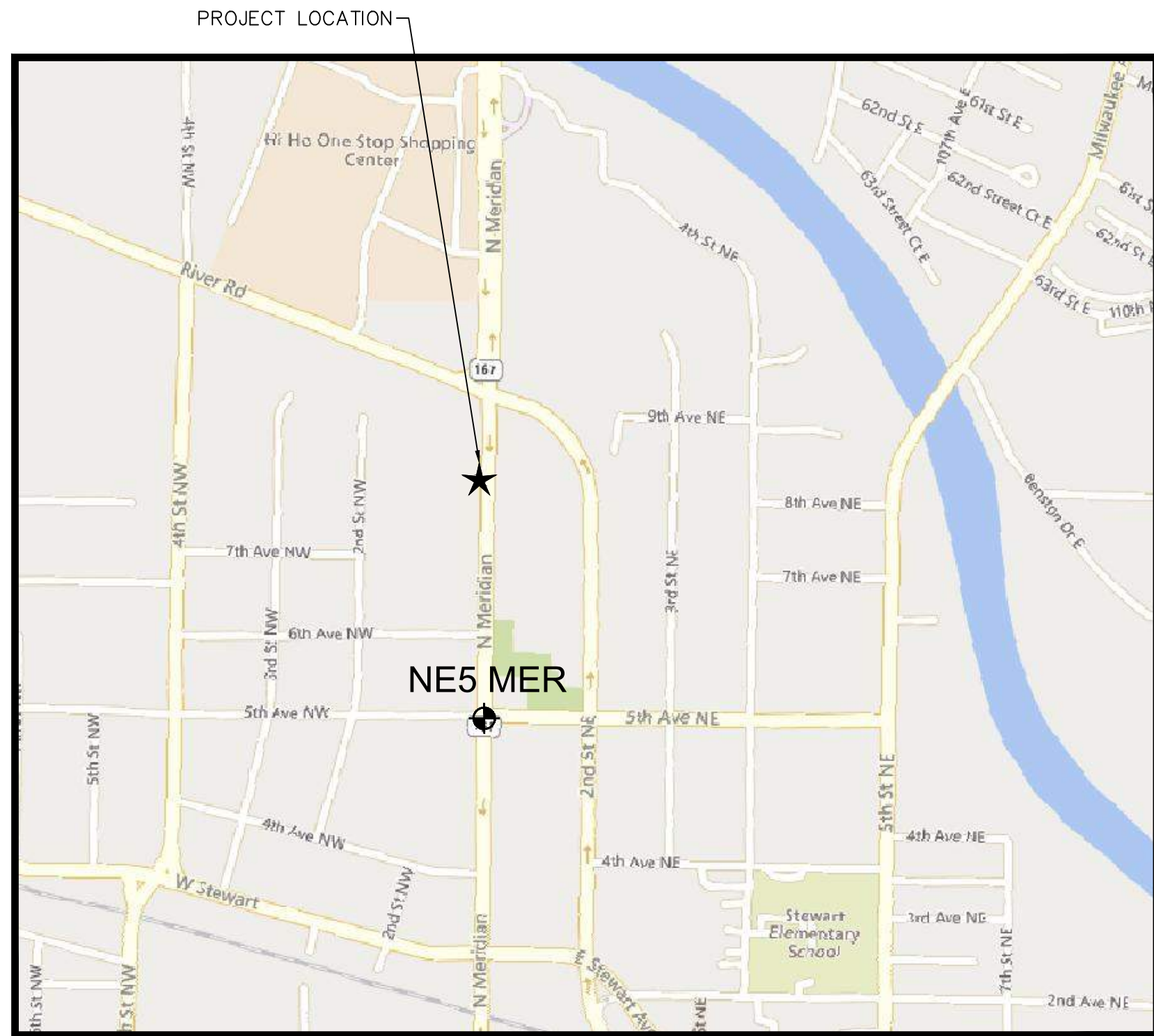

AT&T: MORIAH GOULD
 MG454G@ATT.COM - (971) 832-3579
 MASTEC NETWORK SOLUTIONS: RALETTE CHURCHWELL
 RALETTE.CHURCHWELL@MASTEC.COM - (541) 606-3680

INSTALLATION OF SMALL CELL EQUIPMENT ONTO PROPOSED PUBLIC WORKS METAL LIGHT POLE
 SITE COORDINATES (1A CERTIFICATION) LATITUDE: 47° 11' 50.71" N (47.197419°)
 SITE COORDINATES (1A CERTIFICATION) LONGITUDE: -122° 17' 38.08" W (-122.293911°)
 SITE ELEVATION (1A CERTIFICATION): 43.5' ± 3'

PROJECT DESCRIPTION:
 CITY OF PUYALLUP WORK ORDER REQUEST FOR PROPOSED INSTALLATION OF AT&T SMALL CELL EQUIPMENT AND POWER SERVICE ONTO PROPOSED PUBLIC WORKS METAL STREET LIGHT POLE.

SHEET TITLE
COVER SHEET



NOTE
THE FOLLOWING PLAN SET IS NOT TRANSFERABLE AND IS ONLY CONSIDERED AN OFFICIAL CONSTRUCTION DRAWING WHEN ACCOMPANIED WITH A SIGNED ENGINEERING SEAL.

DATUM
VERTICAL: NAVD 88
HORIZONTAL: NAD 83-91
BENCH MARK: NE5 MER
INTERSECTION: 5TH AVE. NE. & N. MERIDIAN
ELEV. 45.476'

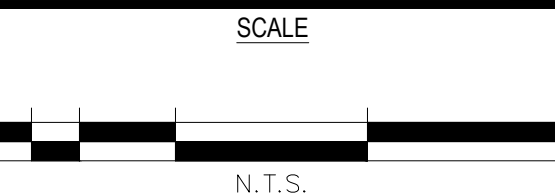

PACE #: MRWOR040047
 SCIP ID #: 27107-50-F
 USID #: 275861
 FA #: 14847400
 POLE TYPE: PUYALLUP PUBLIC WORKS LIGHT POLE
 POLE #: T.B.D.
 LAT: 47.197419° LONG: -122.293911°



UULC:
 UTILITIES UNDERGROUND LOCATION CENTER
 1-800-424-5555 OR 811
 WWW.CALLBEFOREYOU.DIG.ORG/WASHINGTON
 3 WORKING DAYS UTILITY NOTIFICATION PRIOR TO CONSTRUCTION

NO	REVISION	DATE	DP	APPD
7				
6				
5				
4				
3				
2				
1	FOR PERMIT REVIEW	11/30/21	DP	
NO	REVISION			

DATE	BY	DESCRIPTION
04/21/2021	JW	CHECKED
	DP	CREATED
	WA83_SF	COORDINATES

DATE	BY	DESCRIPTION
	KPB	APPROVED
		PROJECT #
		SEGMENT ID

CITY OF PUYALLUP
DEVELOPMENT SERVICES
 JOB TITLE
WATCHM-050-F
709 2ND ST. NW.
DAS SMALL CELL INSTALLATION

DRAWING NO: 1 OF 18

NOTICE: THIS DRAWING AND THE DESIGN SHOWN ARE THE PROPERTY OF TALMAN CONSULTANTS LLC. THE REPRODUCTION, COPYING, OR USE OF THIS DRAWING WITHOUT WRITTEN CONSENT IS PROHIBITED AND ANY INFRINGEMENT WILL BE SUBJECT TO LEGAL ACTION.

DRAWINGS PLOTTED FULL SCALE ON 22X34 SHEETS
DRAWINGS PLOTTED HALF SCALE ON 11X17 SHEETS

Attachment 2
Photo Simulations, Description of Site Equipment & Load Bearing Study

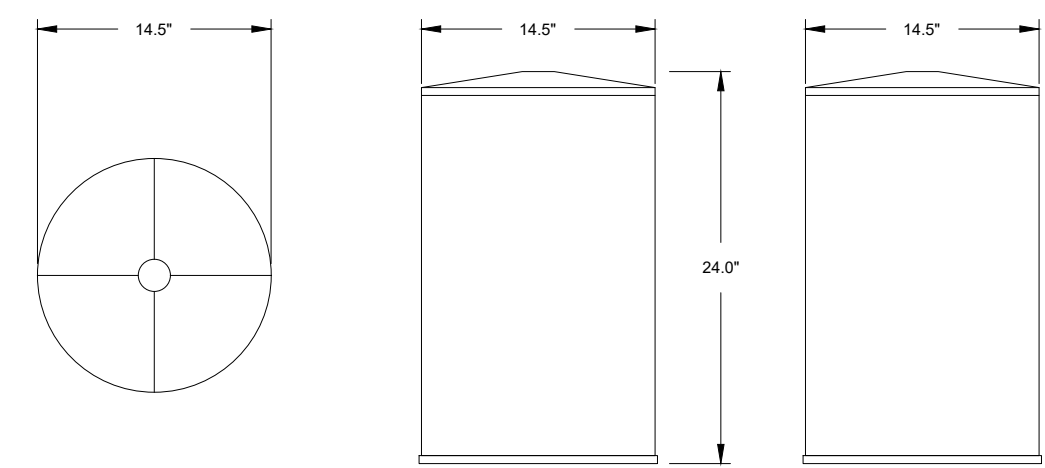

PLAN VIEW FRONT VIEW SIDE VIEW

FREQUENCY RANGE
 LOW BAND 698-896 MHz
 AWS/PCS/WCS BAND #2 1895-2690 MHz
 HIGH BAND #1 3300-4200 MHz
 UNII BAND #2 5150-5925 MHz

**GALTRONICS QUASI-OMNI 12-PORT
 CANISTER ANTENNA**
 MODEL NO. GQ2412-06613

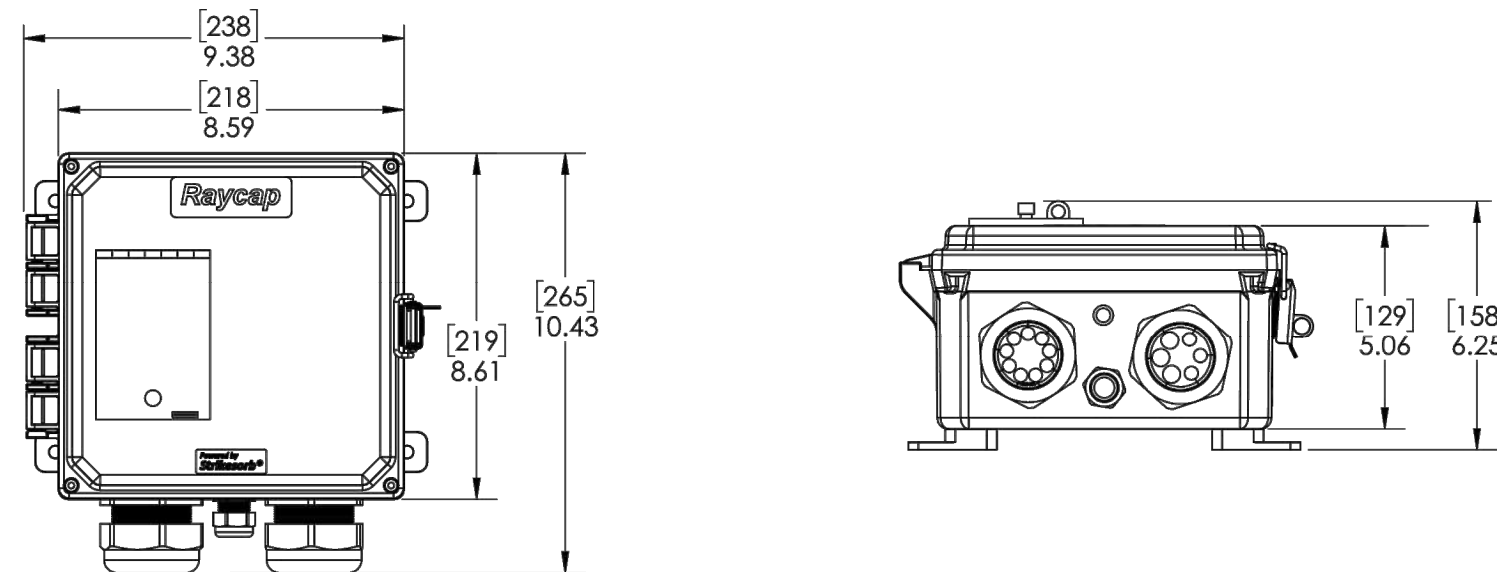

FRONT VIEW PLAN VIEW

RAYCAP AC DISCONNECT BOX
 MODEL NO. RSCAC-1333-P-240-DL

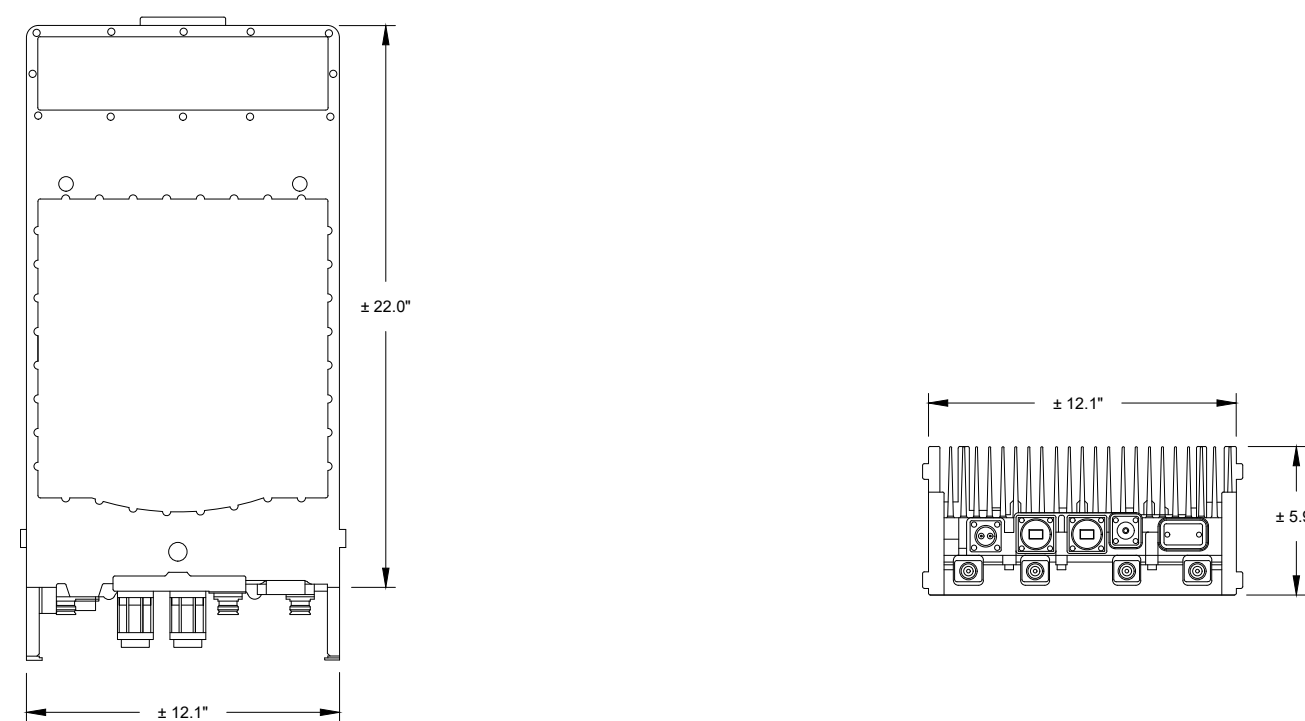

FRONT VIEW BOTTOM VIEW

INTERFACE:
 INPUT POWER:
 2 CPRI PORTS FOR FRONT HAUL (2X9.8 GB/2)
 DC: -36V TO -60V
 AC: 80V TO 276V

NOKIA B25 / B66 AIRSCALE MICRO RRH 4T/4R 320 W (AHFIB)

**Nokia Micro Location
 (using 2 Dual-Band 4T4R Radios)**

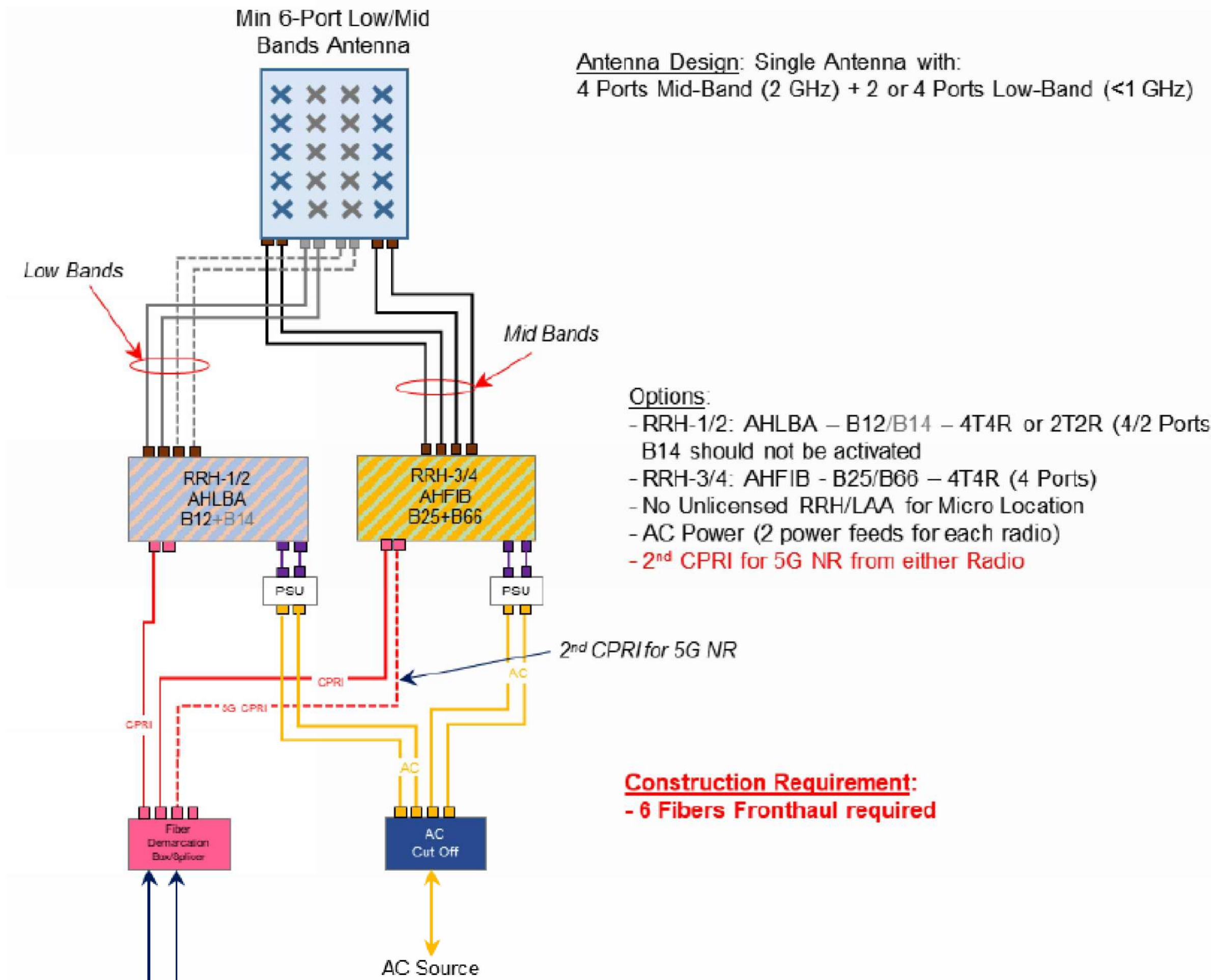

Antenna Design: Single Antenna with:
 4 Ports Mid-Band (2 GHz) + 2 or 4 Ports Low-Band (<1 GHz)

- Options:**
- RRH-1/2: AHLBA - B12/B14 - 4T4R or 2T2R (4/2 Ports)
 B14 should not be activated
 - RRH-3/4: AHFIB - B25/B66 - 4T4R (4 Ports)
 - No Unlicensed RRH/LAA for Micro Location
 - AC Power (2 power feeds for each radio)
 - 2nd CPRI for 5G NR from either Radio

**Construction Requirement:
 - 6 Fibers Fronthaul required**

RF PLUMBING DIAGRAM

OWNER



DEVELOPER



ENGINEER

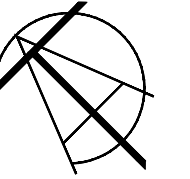

TALMAN
 CONSULTANTS

CONTRACTOR

SHEET TITLE

**EQUIPMENT DETAILS &
 PLUMBING DIAGRAM**



11/30/2021

NOTE
 THE FOLLOWING PLAN SET IS NOT
 TRANSFERABLE AND IS ONLY
 CONSIDERED AN OFFICIAL CONSTRUCTION
 DRAWING WHEN ACCOMPANIED WITH A SIGNED
 ENGINEERING SEAL.

DATUM

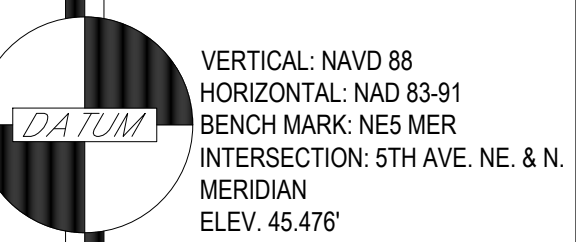

VERTICAL: NAVD 88
 HORIZONTAL: NAD 83-91
 BENCH MARK: NES MER
 INTERSECTION: 5TH AVE. NE. & N.
 MERIDIAN
 ELEV. 45.476'

SCALE



N.T.S.

PACE #: MRWOR040047
 SCIP ID #: 27107-50-F
 USID #: 275861
 FA #: 14847400
 POLE TYPE: PUYALLUP PUBLIC WORKS LIGHT POLE
 POLE #: T.B.D.
 LAT: 47.197419° LONG: -122.293911°



UULC:
 UTILITIES UNDERGROUND LOCATION CENTER
 1-800-424-5555 OR 811
 WWW.CALLBEFOREYOU.DIG.ORG/WASHINGTON
 3 WORKING DAYS UTILITY NOTIFICATION PRIOR TO
 CONSTRUCTION

7					
6					
5					
4					
3					
2					
1					
NO					
	FOR PERMIT REVIEW	11/30/21	DP		
	REVISION	DATE	APPD		

FINAL CONSTRUCTION CHECKED	DATE CREATED	SCALE
	04/21/2021	N.T.S.
CHECKED		APPROVED
JW		KPB
DATE	CREATED	PROJECT #
	DP	MAS-20-4000
FIELD BOOKS	COORDINATES	SEGMENT ID
	WA83_SF	ATT-DASC-522

CITY OF PUYALLUP
DEVELOPMENT SERVICES

JOB TITLE
**WATCM-050-F
 709 2ND ST. NW.
 DAS SMALL CELL INSTALLATION**

DRAWING NO: 12 OF 18



PHOTO SIMULATION
LOOKING NORTHWEST

OWNER



DEVELOPER



ENGINEER



TALMAN
CONSULTANTS

CONTRACTOR

SHEET TITLE

PHOTO SIMULATION

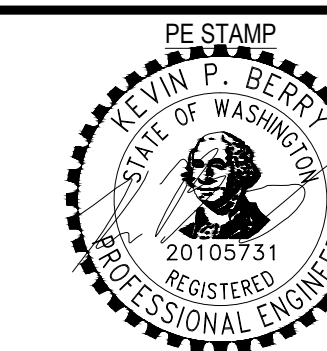

11/30/2021

NOTE
THE FOLLOWING PLAN SET IS NOT
TRANSFERABLE AND IS ONLY
CONSIDERED AN OFFICIAL CONSTRUCTION
DRAWING WHEN ACCOMPANIED WITH A SIGNED
ENGINEERING SEAL.

DATUM

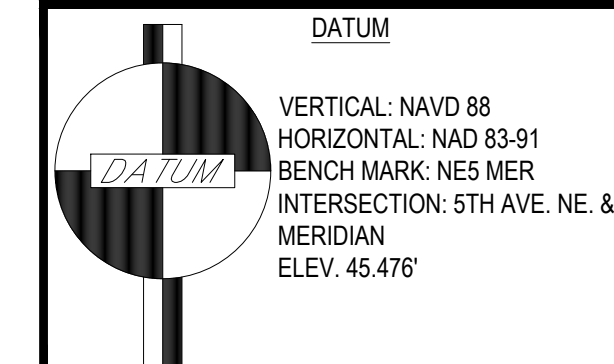

VERTICAL: NAVD 88
HORIZONTAL: NAD 83-91
BENCH MARK: NES MER
INTERSECTION: 5TH AVE. NE. & N.
MERIDIAN
ELEV. 45.476'

SCALE



N.T.S.

PACE #: MRWOR040047
SCIP ID #: 27107-50-F
USID #: 275861
FA #: 14847400
POLE TYPE: PUYALLUP PUBLIC WORKS LIGHT POLE
POLE #: T.B.D.
LAT: 47.197419° LONG: -122.293911°



Know what's below.
Call before you dig.

UULC:
UTILITIES UNDERGROUND LOCATION CENTER
1-800-424-5555 OR 811
WWW.CALLBEFOREYUIDIG.ORG/WASHINGTON
3 WORKING DAYS UTILITY NOTIFICATION PRIOR TO
CONSTRUCTION

7					
6					
5					
4					
3					
2					
1					
NO	FOR PERMIT REVIEW	11/30/21	DP		
	REVISION	DATE	APPD		

	FINAL CONSTRUCTION CHECKED	DATE CREATED 04/21/2021	SCALE N.T.S.
BY	CHECKED JW	APPROVED KPB	
DATE	CREATED DP	PROJECT # MAS-20-4000	
FIELD BOOKS	COORDINATES WA83_SF	SEGMENT ID ATT-DASC-522	

CITY OF PUYALLUP
DEVELOPMENT SERVICES

JOB TITLE
WATCHM-050-F
709 2ND ST. NW.
DAS SMALL CELL INSTALLATION

DRAWING NO: 17 OF 18

NOTICE: THIS DRAWING AND THE DESIGN SHOWN ARE THE PROPERTY OF TALMAN CONSULTANTS LLC. THE REPRODUCTION, COPYING, OR USE OF THIS DRAWING WITHOUT WRITTEN CONSENT IS PROHIBITED AND ANY INFRINGEMENT WILL BE SUBJECT TO LEGAL ACTION.

DRAWINGS PLOTTED FULL SCALE ON 22X34 SHEETS
DRAWINGS PLOTTED HALF SCALE ON 11X17 SHEETS

Exhibit D
Leasehold Excise Tax Exemption

New Cingular Wireless PCS, LLC is centrally assessed by the Washington State Department of Revenue and is therefore statutorily exempt from the Leasehold Excise Tax. Confirmation of this information is available from the Washington State Department of Revenue Miscellaneous Tax Phone Line at (360) 534-1503.

Exhibit E

Insurance Requirements

The Company shall carry and maintain for the duration of this Agreement insurance against claims for injuries to persons or damages to property which may arise from or in connection with the acts or omissions of Company in connection with this Agreement. Such insurance certificates and endorsements evidencing the insurance required below shall be provided to the City upon execution of this Agreement. The cost of such insurance shall be paid by the Company. Insurance shall meet the following limits and shall be maintained for the Term and so long as Company has Site Equipment on any City Poles.

A. No Limitation.

The Company's maintenance of insurance as required by the Agreement shall not be construed to limit the liability of the Company to the coverage provided by such insurance, or otherwise limit the City's recourse to any remedy available at law or in equity.

B. Required Scope of Insurance. The Company shall obtain insurance of the types and coverage described below:

1. Commercial General Liability insurance shall be at least as broad as ISO occurrence form CG 00 01 and shall cover liability arising from premises, operations, independent contractors, products-completed operations, personal injury and advertising injury, and contractual liability coverage. There shall be no exclusion for liability arising from explosion, collapse or underground property damage. The City shall be included as an additional insured under the Company's Commercial General Liability insurance policy with respect to this Agreement using endorsement ISO CG 20 11, Additional Insured – Managers or Lessors of Premises or CG 20 26, or substitute endorsement providing at least as broad coverage.
2. Automobile Liability insurance covering all owned, non-owned, hired and leased vehicles. Coverage shall be at least as broad as Insurance Services Office (ISO) form CA 00 01.
3. Pollution Liability insurance shall be in effect throughout the entire Agreement covering third party claims for bodily injury, property damage or cleanup costs as required by law, where the pollution is caused during and by the Company's operations under this Agreement. The Company may self-insure this risk under the same terms required by this Agreement.
4. Property insurance shall be written on an all risk basis. The Company may self-insure this risk under the same terms required by this Agreement.
5. Workers' Compensation coverage as required by the Industrial Insurance laws of the State of Washington, or the Company must be a qualified self-insurer and provide stop-gap liability coverage under an insured program.
6. Excess or Umbrella Liability insurance shall be excess over and at least as broad in coverage as the Company's Commercial General Liability and Automobile Liability insurance. The City shall be included as an additional insured on the Contractor's Excess or Umbrella Liability insurance policy by endorsement with respect to this Agreement where required on the underlying coverage.

C. Minimum Amounts of Insurance. The Company shall maintain the following insurance limits:

1. Commercial General Liability insurance shall be written with limits of no less than \$5,000,000 each occurrence, \$5,000,000 general aggregate.

2. Automobile Liability insurance with a minimum combined single limit for bodily injury and property damage of \$5,000,000 per accident.

3. Pollution Liability insurance shall be written in an amount of at least \$2,000,000 per loss, with an annual aggregate of at least \$2,000,000.

4. Property insurance shall be written covering the full value of Company's property and improvements with no coinsurance provisions.

5. Excess or Umbrella Liability insurance shall be written with limits of not less than \$10,000,000 per occurrence and annual aggregate. The Excess or Umbrella Liability requirement and limits may be satisfied instead through Company's Commercial General Liability and Automobile Liability insurance, or any combination thereof that achieves the overall required limits.

D. Acceptability of Insurers. Insurance is to be placed with insurers with a current A.M. Best rating of not less than A-: VII.

E. Verification of Coverage. The Company shall annually furnish the City with current original certificates and a copy of the required amendatory endorsements, including but not necessarily limited to the additional insured endorsement, evidencing the insurance requirements of the Agreement, and shall further provided these certificates upon request during the Term of this Agreement. In the event that the City has tendered a claim to Licensee, or its insurer, or its insurer has denied coverage to the City, Licensee (in its Dallas, TX home office) will make available to the City within ten (10) days of the City's written request to Licensee, a copy of actual, authentic and applicable insurance policies for review (but not for copying, faxing or otherwise reproducing any part of any policy or other insurance correspondence), subject to the City first executing a non-disclosure agreement. The policy review is limited to no more than three (3) days during a consecutive six-month period and must be conducted during Licensee's normal business hours while the City's representative is accompanied by a Licensee Risk Management professional. Upon completion of review no copies will be made and all policies will be returned to Licensee's Corporate Risk Management Department.

F. Subcontractors. The Company shall cause each and every Subcontractor to provide insurance coverage that complies with all applicable requirements of the Company-provided insurance as set forth herein, except the Company shall have sole responsibility for determining the limits of coverage required to be obtained by Subcontractors. The Company shall ensure that the City is an additional insured on each and every Subcontractor's Commercial General liability insurance policy using an endorsement as least as broad as ISO CG 2026 or a substitute form providing substantially equivalent coverage.

G. Other Insurance Provisions. Company's Commercial General Liability, Automobile Liability, Excess or Umbrella Liability insurance policy or policies are to contain, or be endorsed to contain, that they shall be primary insurance as respect the City. Any insurance, self-insurance, or self-insured pool coverage maintained by the City shall be excess of the Company's insurance and shall not contribute with it.

H. Notice of Cancellation. Company shall provide the City with at least thirty (30) days written notice of any policy cancellation of any required coverage that is not replaced.

I. Failure to Maintain Insurance. Failure on the part of the Company to maintain the insurance as required shall constitute a material breach of Agreement, upon which the City may, after giving five business days notice to the Company to correct the breach, terminate the Agreement or, at its discretion, procure or renew such insurance and pay any and all premiums in connection therewith, with any sums so expended to be repaid to the City on demand.

J. Company – Self-Insurance. If the Company is self-insured or becomes self-insured during the term of the Agreement, Company or its affiliated parent entity shall comply with the following: (i) provide the City, upon request, a copy of Company’s or its parent company’s most recent audited financial statements, if such financial statements are not otherwise publicly available; (ii) Company or its parent company is responsible for all payments within the self-insured retention; and (iii) Company assumes all defense and indemnity obligations as outlined in the indemnification section of this Agreement.

Exhibit F
Performance Bond

PERFORMANCE AND PAYMENT BOND

CITY OF PUYALLUP

CONTRACT NAME:

JOB NUMBER: _____

KNOW ALL MEN BY THESE PRESENTS that _____,
as Principal, and _____ Company, as
Surety, licensed to do business within Washington State, are held and firmly bound under the City of
Puyallup, State of Washington, in the full sum of _____ Dollars
(\$ _____) lawful money of the United States, for the payment of which well and
truly to be made, we bind ourselves, our heirs, executors and administrators, successors and assigns,
jointly and severally, firmly by these presents.

The conditions of the obligations are such that,

WHEREAS, the Principal has entered into an Agreement in writing with the City of Puyallup
dated _____, 20____, for the **[MLA AND SLA DESCRIPTION - PROJECT
NAME]**, according to the terms, conditions, and covenants specified in the Agreement, which are
hereby referred to and made a part hereof as fully and completely as though set forth in detail herein;
and

WHEREAS, it is understood and a part of the consideration for this obligation that the City of
Puyallup shall have the right to sue on this Bond in its own name to recover for any loss, injury,
damage, or liability whatsoever sustained or incurred by it, by reason of any breach of the Agreement,
or of any provision in this Bond, and for the faithful performance of the Agreement and payment of all
obligations arising thereunder, including but not limited to proper construction, long-term facility
maintenance, rent, timely removal of equipment and restoration, and for the guaranteed payment of
any and all tax liability of any type, kind, nature or description due as a result of this Agreement; and

WHEREAS, suit on this Bond, if brought for breach of performance by Principal as to a
condition hereof (including any condition or performance responsibility incorporated by reference),
may be commenced against both the Principal and Surety as joint and several obligators, with or
without prior notice of such breach of performance by Principal having been given to Surety;

NOW, THEREFORE, if the Principal shall well, truly, and faithfully perform all of the
provisions and fulfill all of the undertakings, covenants, terms, conditions, and agreements of said
Agreement during the period of the original Agreement, and any extension thereof that may be granted
by the City of Puyallup, with or without notice to the Surety, and during the life of any guarantee
required under the Agreement and shall also well and truly perform and fulfill all of the undertakings,
covenants, terms, conditions, and agreements of any and all duly authorized modifications of said
Agreement that may hereafter be made, notice of which modifications to the Surety being hereby
waived.

IT IS FURTHER AGREED that this performance bond shall remain in place until all of
Principal's Site Equipment has been removed by Principal unless otherwise permitted to remain by the
City of Puyallup.

IT IS FURTHER AGREED that in the event any party brings suit to enforce the terms of this
Agreement, the prevailing party shall be entitled to reasonable attorney's fees in addition to other

allowed costs, and suit shall be brought forth in Pierce County, Washington.

IT IS FURTHER DECLARED AND AGREED that nothing of any kind or nature whatsoever that will not discharge the Principal, shall operate as a discharge or release of liability of the Surety, any law, rule of equity, or usage relating to the liability of sureties to the contrary notwithstanding.

SEALED AND DATED THIS _____ day of _____, 20__.

PRINCIPAL:

By: _____
Signature

Print or Type Name

Title: _____

SURETY:

By: _____
Signature

Print or Type Name

Title: _____

Address: _____

Note: If Attorney-in-Fact signs for Surety, a certified copy of the Power of Attorney must be attached.

STATE OF WASHINGTON)
) SS.
COUNTY OF PIERCE)

On this day personally appeared before me _____, to me known to be the individual described in and who executed the within and foregoing instrument and acknowledged to me that he signed the same as his free and voluntary act and deed for the uses and purposes therein mentioned.

GIVEN UNDER MY HAND AND OFFICIAL SEAL this _____ day of _____, 20____.

NOTARY PUBLIC in and for the State of
Washington, residing at _____

STATE OF WASHINGTON)
) SS.
COUNTY OF PIERCE)

On this day personally appeared before me _____, to me known to be the Attorney-in-Fact of the _____ Company, a surety, that executed the within and foregoing instrument, and acknowledged the said corporation for the purposes therein mentioned, and on oath, stated that he was authorized to execute said instrument on behalf of said Surety, and the seal affixed thereto is the corporate seal of said Surety corporation.

NOTARY PUBLIC in and for the State of
Washington, residing at _____

Exhibit G
Contact Information

Site Equipment Manager: Moriah Gould
cRAN Site Acquisition PM – WA
AT&T Mobility PNW
mg454q@att.com
971.832.3579

Secondary Site Equipment Manager: Tyrell Fincher
Area Manager, C&E cRAN, PNW Market
AT&T Mobility PNW
tf408s@att.com
206.387.6347

City Contact: Hans Hunger, P.E. - City Engineer
City of Puyallup
333 South Meridian
Puyallup, WA 98371
Phone 253.435.3640 - cell 253-225-4241
hhunger@PuyallupWA.gov