



## **Building Systems Submittal Package**

**Good Samaritan Hospital  
407 14th Avenue  
Puyallup, WA.  
East Wing**

**AHU Replacement TI  
Fire Alarm System**

**Revision Date: 2/28/2022**

**Johnson Controls Fire Protection  
9520 10th Avenue South, Suite 100  
Seattle, WA 98108  
Phone: 206-291-1400  
Fax: 206-291-1500  
[www.JohnsonControls.com](http://www.JohnsonControls.com)**

**Precision Electric Group  
15301 NE 90th St, Suite 150  
Redmond, WA 98052  
Phone: 425-823-8600  
Contact: Casey Beach**



**This Page Left Blank Intentionally**



## **Table of Contents**

- Section I:           Scheduling/Installation Checklist**
- Section II:          Hardware Warranty**
- Section III:         Manufacturer's Recommendation**
- Section IV:         Testing Procedure for Devices**
- Section V:          Equipment List & Equipment Datasheets**



**This Page Left Blank Intentionally**



## Scheduling

Thank you for working with Johnson Controls on this project. We would like to take this opportunity to introduce you to the project team. **REILLY NELSON** is the Johnson Controls Project Manager assigned to this project to help with generic project information. **SCOTT HAYNES** is the project system specialist to assist with drawings/design questions. **YVONNE THOMPSON** is available for scheduling technicians.

Office: (206) 291-1400

Fax: (206) 291-1500

In an effort to assist you in your installation we require you to arrange a Pre-Construction meeting with one of our Technicians. This meeting will allow your field foreman to ask any questions they may have in regard to the installation of your system. Based on the equipment quantities and current scope of work our Technician will need no less than **30** business days to complete all necessary programming and commissioning from the time the below checklist is complete prior to any AHJ testing. Please make sure this time is allowed for in the General Construction CPM schedule as it cannot be compressed. Change orders, change of scope, etc. may require additional time allotment to field personnel.

## Installation Checklist

Johnson Controls is committed to providing the highest quality service available. As part of this service we want to ensure that the installation results in a trouble-free system. Please review the Checklist below and ensure each item is complete prior to our site visit.

A Technician will be dispatched only after the below checklist items have been completed. If these items are not completed prior to the visit by our technician, you may incur additional charges not covered by our quotation. Please feel free to contact our office if you have any questions.

- Fire Alarm Panel(s) have been mounted and all wiring (power, IDNET, signal, door-holders, etc.) pulled into panel(s).
- All wiring pulled into panel(s) or junction boxes have been permanently marked with wire markers and can easily be identified by a Johnson Controls
- System Power is supplied and on a dedicated circuit (Do Not Energize prior to Technician visit).
- All peripheral devices have been mounted (Smoke Detectors still covered).
- All end-of-line resistors have been installed.
- All alarm initiating circuits (smoke detectors, pull stations, etc.) have been checked for shorts, opens and grounds.
- All alarm notification circuits (speakers, horns, strobes, etc.) have been checked for shorts, opens and grounds.
- All remaining wiring (door-holders, FACP 24VDC, etc.) has been checked.
- Flows, Tamper, and Pressure Switches installed, properly wired and adjusted.
- All devices are properly protected against construction dust and contamination.
- Contact us immediately if there is no digital dialer or system monitoring provisions already in place. The dialer, phone lines and service will be required for system testing.
- There are no missing parts or equipment.



**This Page Left Blank Intentionally**



## Hardware Warranty

- 1) JOHNSON CONTROLS WARRANTY STATEMENT:
  - a) JOHNSON CONTROLS WARRANTS TO THE PURCHASER OF NEW JOHNSON CONTROLS PRODUCT(S) THAT THE PRODUCTS SHALL BE FREE FROM DEFECTS IN WORKMANSHIP AND MATERIAL.
- 2) WARRANTY PERIOD:
  - a) THE WARRANTY PERIOD WILL TERMINATE IMMEDIATELY FOLLOWING THE EARLIEST OCCURRENCE OF EITHER OF THE FOLLOWING:
    - i) 18 MONTHS HAVE ELAPSED FOLLOWING SHIPMENT OF ANY SYSTEM OR SUB-SYSTEM FROM JOHNSON CONTROLS TO THE CUSTOMER, OR
    - ii) 12 MONTHS HAVE ELAPSED FOLLOWING THE FINAL CONNECTION OPERATION AND BENEFICIAL USE OF ALL OR ANY PART OF THE SYSTEM.
    - iii) AS STATED IN THE SPECIFICATIONS AND/OR CONTRACT DRAWINGS
- 3) JOHNSON CONTROLS OBLIGATION UNDER THE TERMS OF THE WARRANTY:
  - a) JOHNSON CONTROLS'S SOLE RESPONSIBILITY SHALL BE TO REPAIR, ADJUST OR REPLACE, AT ITS OPTION, ANY JOHNSON CONTROLS PRODUCT WHICH FAILS DURING THIS PERIOD PROVIDING PURCHASER HAS PROMPTLY REPORTED SUCH FAILURE TO JOHNSON CONTROLS IN WRITING. REPLACEMENT PARTS WILL BE WARRANTED ONLY FOR THE BALANCE OF THE EQUIPMENT WARRANTY. JOHNSON CONTROLS AGREES TO CONTINUE TO HONOR ALL OF THE UNEXPIRED EXPRESSED WARRANTIES SPECIFIED ABOVE ON DEFECTIVE EQUIPMENT AFTER TRANSFER OF THE EQUIPMENT TO PURCHASER'S CUSTOMER, PROVIDED PURCHASER'S CUSTOMER ASSUMES THE PURCHASER'S OBLIGATIONS SPECIFIED BELOW.
  - b) EXCEPT FOR THE EXPRESSED WARRANTIES STATED HEREIN, JOHNSON CONTROLS DISCLAIMS ALL WARRANTIES ON PRODUCTS FURNISHED HEREUNDER, INCLUDING WITHOUT LIMITATION, ALL IMPLIED WARRANTIES OF MERCHANTABILITY AND FITNESS FOR A PARTICULAR PURPOSE, AND THE STATED WARRANTIES ARE IN LIEU OF ALL OBLIGATIONS OR LIABILITIES ON THE PART OF THE JOHNSON CONTROLS ARISING OUT OF OR IN CONNECTION WITH THE PERFORMANCE OF THE PRODUCTS. THE SELLER SHALL NOT BE LIABLE FOR ANY DIRECT, INCIDENTAL OR CONSEQUENTIAL LOSS OR DAMAGE TO THE PRUCHASER OR USER OF THIS EQUIPMENT ARISING OUT OF THE FAILURE OF THE EQUIPMENT TO OPERATE IN EXCESS OF THE PURCHASE PRICE OF SAID EQUIPMENT.
  - c) JOHNSON CONTROLS MAKES NO WARRANTY AND NO WARRANTY SHALL BE DEEMED TO EXIST, THAT PURCHASER HOLDS THE GOODS FREE OF THE CLAIM OF ANY THIRD PERSON BYWAY OF PATENT INFRINGEMENT OR THE LIKE.
- 4) PURCHASER'S OBLIGATIONS UNDER THE TERMS OF THE WARRANTY.
  - a) THIS WARRANTY IS CONTINGENT UPON THE PROPER INSTALLATION AND USE OF THE PRODUCT(S). SUCH WARRANTY SHALL NOT APPLY IF THE PRODUCT FAILURE IS THE RESULT OF ACCIDENT, UNUSUAL PHYSICAL, ELECTRICAL OR ELECTROMECHANICAL STRESS, NEGLIGENCE, MISUSE, USER PROGRAMMING ERRORS, FAILURE OF ELECTRICAL POWER, AIR CONDITIONING OR HUMIDITY CONTROL, CONSTRUCTION DUST, DAMAGING FOREIGN SUBSTANCES, TRANSPORTATION OR CAUSES OTHER THAN MANUFACTURING DEFECT. PURCHASER AGREES TO PROVIDE FULL AND FREE ACCESS TO AUTHORIZED JOHNSON CONTROLS EMPLOYEES.
  - b) WARRANTY SERVICE HOURS
    - i) SERVICES PROVIDED UNDER THIS WARRANTY WILL BE PERFORMED DURING THE HOURS OF 8:00A.M. TO 5:00P.M., MONDAY THROUGH FRIDAY, EXCLUDING LOCALLY OBSERVED JOHNSON CONTROLS HOLIDAYS. OFF HOURS RESPONSE IS AVAILABLE AS AN EXTRA COST SERVICE OPTION.
- 5) WARRANTY EXCLUSIONS:
  - a) LABOR, TRAVEL, AND MILEAGE FOR:
    - i) SERVICE OUTSIDE OF JOHNSON CONTROLS NORMAL BUSINESS HOURS.
    - ii) PROGRAMMING AND/OR LABEL CHANGES.
    - iii) FAILURE DUE TO EXTERNAL CAUSES (LIGHTNING SURGES, CONSTRUCTION DUST, ETC.) OTHER THAN MANUFACTURING DEFECT.
  - b) ELECTRICAL WORK EXTERNAL TO THE EQUIPMENT SUPPLIED BY JOHNSON CONTROLS OR MAINTENANCE OF ACCESSORIES, ALTERATIONS, ATTACHMENTS OR OTHER DEVICES NOT FURNISHED BY JOHNSON CONTROLS.
  - c) BATTERIES.
  - d) COVERAGE OF EQUIPMENT CLASSED AS A WATER FLOW MONITORING/CONTROL DEVICES INSTALLED IN OR ON WATER PIPING.



**This Page Left Blank Intentionally**





## Manufacturer's Recommendation

- 1) CONTRACTOR IS EXPECTED TO PULL AND TERMINATE ALL CONDUCTORS AND INSTALL ALL DEVICES FOR A COMPLETE AND OPERATING SYSTEM.
- 2) WHERE FAN SHUTDOWN, ELEVATOR RECALL OR SPECIAL AUXILIARY FUNCTIONS ARE REQUIRED, CONTRACTOR IS TO VERIFY WIRING REQUIREMENTS WITH THE JOHNSON CONTROLS FACTORY TECHNICIAN ASSIGNED TO THE PROJECT (IN MANY CASES, SPECIAL WIRING WILL NOT BE SHOWN ON THE DRAWINGS).
- 3) WHERE POSSIBLE, THE CONTRACTOR IS TO USE COLOR CODE FOR ALL WIRING.
- 4) SMOKE DETECTORS ARE NOT TO BE MOUNTED WITHIN 3 FEET OF AIR OUTLETS.
- 5) CONTRACTOR MUST NOT INSTALL SMOKE DETECTOR HEADS IN BASES OR DUCT HOUSING UNTIL FINAL CHECKOUT TIME TO ENSURE THAT DIRT OR DUST DOES NOT CONTAMINATE THE UNITS. DIRTY DETECTORS ARE NOT COVERED BY WARRANTY.
- 6) DO NOT POWER-UP SYSTEM UNTIL JOHNSON CONTROLS FACTORY TECHNICIAN IS PRESENT.
- 7) A SEPARATE GROUND (ISOLATION FROM CONDUIT GROUND) MUST BE PULLED TO ALL CABINETS.
- 8) LOADS GREATER THAN 10 AMPS (FOR AUXILIARY FUNCTIONS) ARE NOT ALLOWED IN THE SAME CONDUIT AS FIRE ALARM.
- 9) CONTRACTOR IS TO ENSURE THAT ALL WIRING AND SHIELDS ARE FREE OF SHORTS, GROUNDS AND OPENS.
- 10) UNDERGROUND WIRING MUST MAINTAIN ONE MEGAOHM, 20F RESISTANCE TO GROUND.
- 11) ANY MANUFACTURER'S RECOMMENDATION IN CONFLICT WITH ENGINEERING DRAWINGS OR SPECIFICATIONS SHALL BE BROUGHT TO THE ATTENTION OF THE ENGINEER FOR CLARIFICATION. CONTRACTOR SHALL ADVISE JOHNSON CONTROLS OF ANY CHANGES.
- 12) PROTECTIVE COVERS ON SMOKE DETECTORS ARE NOT TO BE REMOVED UNTIL OWNERS ACCEPTANCE OF THE SYSTEM. (PREVENTS CONTAMINATION OF SMOKE CHAMBER).
- 13) IT IS THE CONTRACTOR'S RESPONSIBILITY TO REQUEST THE STATE OR LOCAL FIRE MARSHAL TO BE ON SITE FOR FINAL ACCEPTANCE AND CHECK OUT IF REQUIRED.
- 14) IT IS THE CONTRACTOR'S RESPONSIBILITY TO INVENTORY ALL EQUIPMENT RECEIVED FROM JOHNSON CONTROLS AGAINST THE CONTRACT DOCUMENTS AND REPORT ANY DISCREPANCIES WITHIN THIRTY (30) DAYS OR JOHNSON CONTROLS WILL ASSUME THE ORDER TO BE ACCURATE AND COMPLETE.
  - a) \*NOTE: IN THE EVENT OF DISCREPANCIES IN THE NUMBER OF DEVICES SUPPLIED, THE FOLLOWING JOHNSON CONTROLS POLICY WILL APPLY:
    - i) TOO FEW DEVICES: IF THE DEVICE IS SHOWN ON THE CONTRACT DOCUMENTS AND HAS NOT BEEN ADDED AS A RESULT OF A POST BID ADDITION OR CHANGE ORDER, JOHNSON CONTROLS WILL SUPPLY THE DEVICE AT NO CHARGE TO THE CONTRACTOR OR END USER PER JOHNSON CONTROLS'S CONTRACT OBLIGATIONS.
    - ii) TOO MANY DEVICES: IF THE DEVICE SHOWN IS EXTRA, DUE TO A POST BID ADDITION OR CHANGE ORDER; IT REMAINS THE PROPERTY OF THE CONTRACTOR OR END USER. IF THE DEVICE IS EXTRA DUE TO AN ERROR IN QUANTITIES SUPPLIED, THE DEVICE MUST BE RETURNED TO JOHNSON CONTROLS. NO CREDIT WILL BE ISSUED FOR THE RETURN OF EXTRA EQUIPMENT ABOVE THE QUANTITIES GIVEN IN THE CONTRACT DOCUMENTS.
- 15) OWNERS PRESENCE FOR FINAL DEMONSTRATION AND ACCEPTANCE.



## Special Instructions - Johnson Controls

- 1) JOHNSON CONTROLS WILL PROVIDE WIRING INSTRUCTIONS FOR INSTALLATION OF JOHNSON CONTROLS EQUIPMENT.
- 2) JOHNSON CONTROLS WILL PROVIDE A FACTORY TRAINED TECHNICIAN TO ASSIST IN TRAINING:
  - a) OPERATION OF THE CONTROL PANEL AND FUNCTIONS
  - b) ALARM TEST OF ALL JOHNSON CONTROLS PERIPHERAL DEVICES (SMOKE DETECTOR, MANUAL PULL STATION, ETC.)
  - c) SUPERVISE TEST OF ALL INITIATING, SIGNALING, AND CONTROL CIRCUITS.
- 3) JOHNSON CONTROLS WILL PROVIDE (1) INSTRUCTION AT FINAL TEST OF THE SYSTEM TO:
  - a) OWNER REPRESENTATIVE
  - b) FIRE INSPECTOR AND ELECTRICAL INSPECTOR
  - c) ARCHITECT AND ENGINEER
- 4) UPON COMPLETION OF FINAL TEST, JOHNSON CONTROLS WILL PROVIDE:
  - a) TEST REPORT
  - b) CERTIFICATION (IF REQUIRED)
  - c) ONE YEAR WARRANTY



## Testing Procedure for Devices

### **GENERAL:**

FOR ALL DEVICES (SUPPLIED BY JOHNSON CONTROLS) VISUALLY VERIFY PROPER LOCATION AND INSTALLATION.

### **SMOKE DETECTOR:**

ACTIVATE THE DEVICE USING A SMOKE GENERATOR AND VERIFY ALARM CONDITION ON PANEL. RESET PANEL AND VERIFY RESET OF SMOKE DETECTOR AND PANEL. TEST FOR ALARM VERIFICATION IF APPROPRIATE.

### **HEAT DETECTOR:**

FIXED TEMPERATURE REPLACEMENT ELEMENT - REMOVE ELEMENT ON HEAT DETECTOR TO INITIATE ALARM AND VERIFY ALARM CONDITION AT PANEL. REINSTALL ELEMENT, RESET SYSTEM, AND VERIFY.

NON-REPLACEABLE ELEMENT - NON-REPLACEABLE ELEMENT HEAT DETECTORS CAN ONLY BE TESTED FOR CONTINUITY.

RATE-OF-RISE DETECTORS - RATE OF RISE DETECTORS ARE TESTED WITH A HEATER OR BLOW DRYER UNTIL THEY INITIATE ALARM, THEN ALLOWED TO COOL. RESET PANEL AND VERIFY.

### **PULL STATIONS:**

ACTIVATE STATION WITH THE T-HANDLE, VERIFY ALARM AND LABEL FOR LOCATION, RESET STATION, RESET PANEL.

### **DUCT DETECTOR:**

(IF PROVIDED BY JOHNSON CONTROLS) WITH AIR HANDLING UNIT TURNED ON, OPEN ONE OF THE TEST PORT HOLES BY REMOVING THE RED COVER ON THE DUCT DETECTOR/SENSOR HOUSING. USING AN EXTENDED NOZZLE ON THE SMOKE DETECTOR AEROSOL TESTER SPRAY A FOUR TO EIGHT SECOND BURST OF AEROSOL THROUGH THE TEST PORT BUT NOT DIRECTLY AT THE DETECTOR/SENSOR HEAD. THE NOZZLE OF THE SMOKE DETECTOR AEROSOL TESTER SHOULD NOT EXTEND BEYOND THE INLET TUBE. AEROSOL IS SPRAYED INTO THE STREAM OF INCOMING AIR AND NOT DIRECTLY INTO DETECTOR/SENSOR. VERIFY ALARM, TEST ALL INDICATORS OR MANUAL TEST SWITCHES, RESET DETECTOR, RESET PANEL, TEST SAMPLE AND REFERENCE TUBE FOR POSITIVE AIR FLOW. (IF NOT PROVIDED BY JOHNSON CONTROLS) VERIFY THAT ZONE CIRCUIT IS PRESENT AT THE DEVICE.

### **AUDIBLES AND VISIBLES:**

ACTIVATE ALARM AND CONFIRM THAT ALL INDICATING APPLIANCES, AUDIBLES AND VISIBLES, ARE OPERATING.

### **DOOR HOLDERS:**

VERIFY THAT DOORS CLOSE ON ALARM.

### **VALVE SUPERVISORY SWITCHES (TAMPER):**

(IF PROVIDED BY JOHNSON CONTROLS) ACTIVATE SWITCH BY MOVING VALVE OFF NORMAL, VERIFY STATUS CHANGE, RESET SWITCH, RESET PANEL. (IF NOT PROVIDED BY JOHNSON CONTROLS) VERIFY THAT ZONE CIRCUIT IS PRESENT AT THE SWITCH.

### **FLOW SWITCHES AND PRESSURE SWITCHES:**

(IF PROVIDED BY JOHNSON CONTROLS) ACTIVATE SWITCH (WITH SPRINKLER CONTRACTOR PRESENT) BY A FLOW OF WATER, VERIFY STATUS CHANGE, RESET SWITCHES, RESET PANEL. (IF NOT PROVIDED BY JOHNSON CONTROLS) VERIFY THAT ZONE CIRCUIT IS PRESENT AND SUPERVISED AT THE SWITCH.

### **FAN/DAMPER CONTROL CIRCUITS:**

VERIFY (WITH HVAC CONTRACTOR PRESENT) THAT THE CONTROL CIRCUIT IS OPERATING, AND THE DEVICES IS BEING CONTROLLED IN ACCORDANCE WITH THE SPECIFIED SEQUENCE OF OPERATION.

### **ELEVATOR CONTROL CIRCUITS:**

VERIFY (WITH ELEVATOR CONTRACTOR PRESENT) THAT THE ELEVATOR IS BEING CONTROLLED IN ACCORDANCE WITH THE SPECIFIED SEQUENCE OF OPERATION.

### **TRAINING:**

JOHNSON CONTROLS SHALL PROVIDE A ONE TRAINING SESSION TO THE CUSTOMER.

### **WARRANTY:**

THE SYSTEM SHALL BE PROVIDED WITH A ONE YEAR HARDWARE WARRANTY.



**This Page Left Blank Intentionally**



## Equipment List & Data Sheets Fire Alarm System

<u>Quantity</u>	<u>Product ID</u>	<u>Product Description</u>
2	4098-9756	DUCT DETECTOR
2	4098-9858	SAMPLING TUBE
2	2098-9806	REMOTE TEST SWITCH

**Equipment List Subject to Change.**



**This Page Left Blank Intentionally**

UL, ULC, CSFM Listed; FM Approved;  
MEA (NYC) Acceptance\*

Addressable Duct Sensor Housings with TrueAlarm  
Photoelectric Sensor; Available with Multiple Relay Control

### Features

**Compact air duct sensor housing with clear cover to monitor for the presence of smoke\*\***

**Includes factory installed TrueAlarm photoelectric smoke sensor and features:**

- Individual sensor information processed by the host control panel to determine sensor status
- Digital transmission of analog sensor values via IDNet or MAPNET II, 2-wire communications
- Programmable sensitivity, consistent accuracy, environmental compensation, status testing, and monitoring of sensor dirt accumulation

#### Model 4098-9755:

- Basic duct sensor housing (no relay output) powered by IDNet/MAPNET II communications

#### Model 4098-9756:

- Duct sensor housing with supervised output for multiple remote relays; requires separate 24 VDC; includes one relay
- Relay output is under panel control
- At the panel, relay output can be activated manually or in response to a separate alarm or other input

#### General features:

- UL listed to Standard 268A
- Clear cover allows visual inspection
- Test ports provide functional smoke testing access with cover in place
- Mounts to rectangular ducts or round ducts; minimum size is 8" (203 mm) square or 18" (457 mm) diameter
- Magnetic test feature for alarm initiation at housing
- Optional weatherproof enclosure is available separately (refer to data sheet S4098-0032)

#### Diagnostic LEDs (on interface board):

- Red Alarm/Trouble LED for sensor status and communications polling display
- Yellow LED for open or shorted trouble indication of supervised relay control (4098-9756 only)

#### Sampling tubes (ordered separately):

- Available in multiple lengths to match duct size
- Installed and serviced with housing in place

#### Remote module options (ordered separately):

- Remote red status/alarm LED (2098-9808)
- Remote test station with LED (2098-9806)
- 4098-9843 remote relays (refer to page 2 for details)

\* These products have been approved by the California State Fire Marshal (CSFM) pursuant to Section 13144.1 of the California Health and Safety Code. See CSFM Listing 3240-0026.241 for allowable values and/or conditions concerning material presented in this document. Accepted for use – City of New York Department of Buildings – MEA35-93E. Additional listings may be applicable; contact your local Simplex product supplier for the latest status. Listings and approvals under Simplex Time Recorder Co. are the property of Tyco Fire Protection Products.

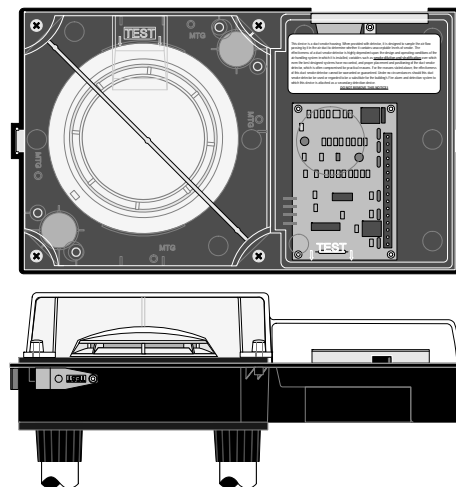

Duct Sensor Housing, Front and Bottom View

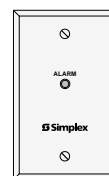

2098-9808

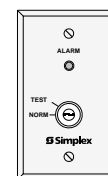

2098-9806

Remote Status/Alarm Indicator and Test Station

### Introduction

**Operation.** Simplex® compact air duct smoke sensor housings provide TrueAlarm operation for the detection of smoke in air conditioning or ventilating ducts. Sampling tubes are installed into the duct allowing air to be directed to the smoke sensor mounted in the housing.

### TrueAlarm Sensor Operation

#### Digital Communication of Analog Sensing.

Analog information from the sensor is digitally communicated to the control panel where it is analyzed. Sensor input is stored and tracked as an average value with an alarm or abnormal condition being determined by comparing the sensor's present value against its average.

**Intelligent Data Evaluation.** Monitoring each photoelectric sensor's average value provides a software filtering process that compensates for environmental factors (dust, dirt, etc.) and component aging, providing an accurate reference for evaluating new activity. The result is a significant reduction in the probability of false or nuisance alarms caused by shifts in sensitivity, either up or down.

\*\* Please note that smoke detection in air ducts is intended to provide notification of the presence of smoke *in the duct*. It is not intended to, and will not, replace smoke detection requirements for open areas or other non-duct applications.

## TrueAlarm Sensor Operation (Continued)

**Control Panel Selection.** Peak activity per sensor is stored to assist in evaluating specific locations. The alarm set point for each sensor is determined at the control panel, selectable as the individual application requires.

**Sensor Status LED.** Each sensor housing's red status LED (located on the electrical interface board) pulses to indicate communications with the panel. If the control panel determines that a sensor is in alarm, or that it is dirty or has some other type of trouble, the details are annunciated at the control panel and that sensor housing's status LED will be turned on steadily. During a system alarm, the control panel will control the LEDs such that an LED indicating a trouble will return to pulsing to help identify any alarmed sensors. (Remote Status/Alarm LEDs track the operation of the sensor housing LED.)

## Photoelectric Sensing

TrueAlarm photoelectric sensors use a stable, pulsed infrared LED light source and a silicon photodiode receiver to provide consistent and accurate low power smoke sensing.

## Duct Sensor Selection Chart

### Duct Smoke Sensor Housing with Photoelectric Sensor\*

Model	Description	Compatibility
4098-9755	Basic Duct Sensor Housing; operating power is supplied by either IDNet or MAPNET II communications (no relay output)	4007ES, 4008, 4010, 4010ES, 4020, 4100, 4100ES, 4100E, and 4120. Also 2120 CDT if configured for MAPNET II, TrueAlarm operation
4098-9756	Duct Sensor Housing with supervised multiple relay output, requires separate 24 VDC fire alarm power and 4081-9008 end-of-line resistor harness; includes one 4098-9843 relay	Same as above except relay operation is not compatible with 2120 CDT; Relay output is for up to 15 total 4098-9843 Relays (additional relays are ordered separately)

### Remote LED Indicator and Test Station, Select One if Required

Model	Description	Compatibility	Mounting
2098-9808	Red LED status indicator on single-gang stainless steel plate	4098-9755 4098-9756	Use single gang box, 3" H x 2" W x 2" D (76 mm x 51 mm x 51 mm)
2098-9806	Test Station with keyswitch and red LED status indicator, on single-gang stainless steel plate; (turning switch to "TEST" initiates alarm for system testing)		

### Epoxy Encapsulated Remote Relay and End-of-Line Resistor

Model	Description	Compatibility	Location
4098-9843	Relay; single Form C (7 A @ 120 VAC); refer to pages 3 and 4 for additional relay information; one included with 4098-9756; wiring is 18 AWG (0.82 mm <sup>2</sup> ) color coded wire leads	4098-9756 only; connect up to 15	Locate relays within 3 ft (1 m) of device being controlled per NFPA 72
4081-9008	End-of-Line Resistor Harness; 10 kΩ, 1/2 W; (ref. 733-894); required to supervise remote relay coil connection	4098-9756	At last relay location

\* Each duct housing includes an internally mounted model 4098-9714 TrueAlarm photoelectric sensor and an exhaust tube. A correctly sized sampling tube (ordered per application) is required, refer to chart below.

## Sampling Tube Selection Chart, Ordered Separately Per Duct Width, Select One

Overall Duct Width	Tube Required	Suggested Cut Length
12" (305 mm)	<b>4098-9854</b>	1/2" (12.7 mm) longer than duct width
13" to 23" (330 mm to 584 mm)	<b>4098-9855</b>	1/2" (12.7 mm) longer than duct width
24" to 46" (610 mm to 1168 mm)	<b>4098-9856</b>	3 in" (76 mm) longer than duct width
46" to 71" (1168 mm to 1803 mm)	<b>4098-9857</b>	3 in" (76 mm) longer than duct width
71" to 95" (1803 mm to 2413 mm)	<b>4098-9858</b>	3 in" (76 mm) longer than duct width

## Photoelectric Sensing (Continued)

Typically duct sensor applications require less sensitive settings (such as 2.5% per foot obscuration) due to the ducts being a relative dirty environment. However, the standard seven levels of TrueAlarm sensor sensitivity are available for each individual sensor, ranging from 0.2% to 3.7% per foot of smoke obscuration. Sensitivity is selected and monitored at the fire alarm control panel.

## Fire Alarm Control Panel Features

- Individual smoke sensitivity selection
- Sensitivity monitoring that satisfies NFPA 72 sensitivity testing requirements
- Peak value logging allows accurate analysis for sensitivity selection
- Automatic, once per minute individual sensor calibration check verifies sensor integrity
- Automatic environmental compensation
- Smoke sensitivity is displayed in percent per foot
- Ability to display and print detailed sensor information in plain English language
- Relays of model 4098-9756 are under panel control for ON, OFF, or override



# Duct Sensor Housing Detail Reference

**NOTE:** Refer to Installation Instructions 574-776 for additional installation detail and maintenance information.

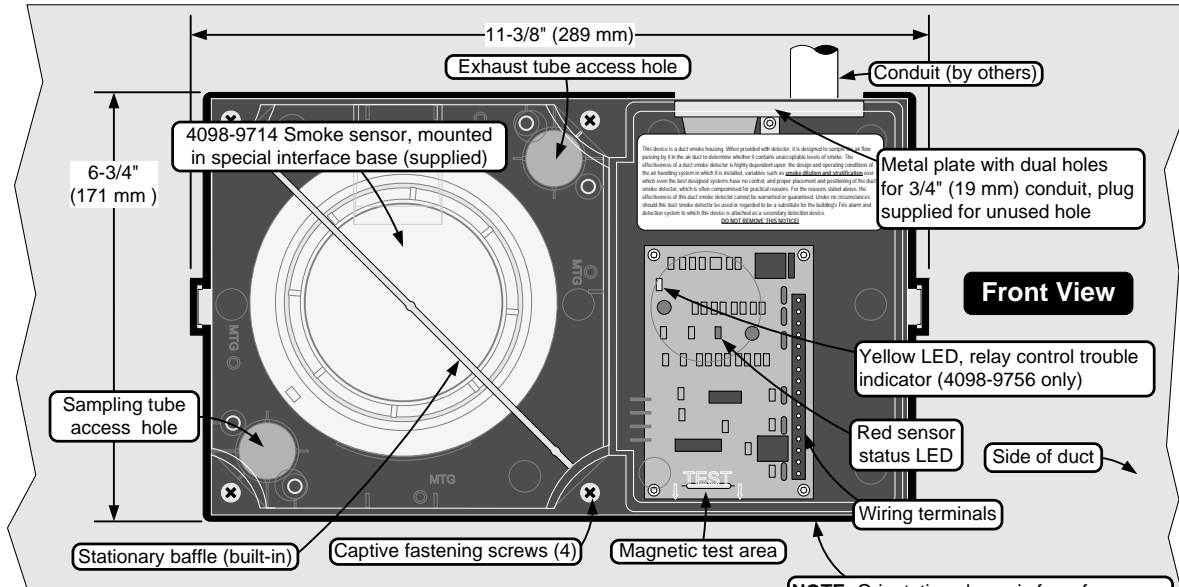

**NOTE:** Orientation shown is for reference only, refer to General Location Notes and End View illustration below for alternate mounting reference.

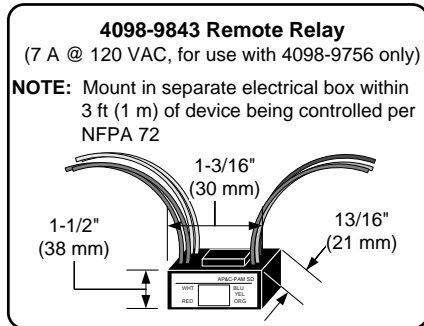
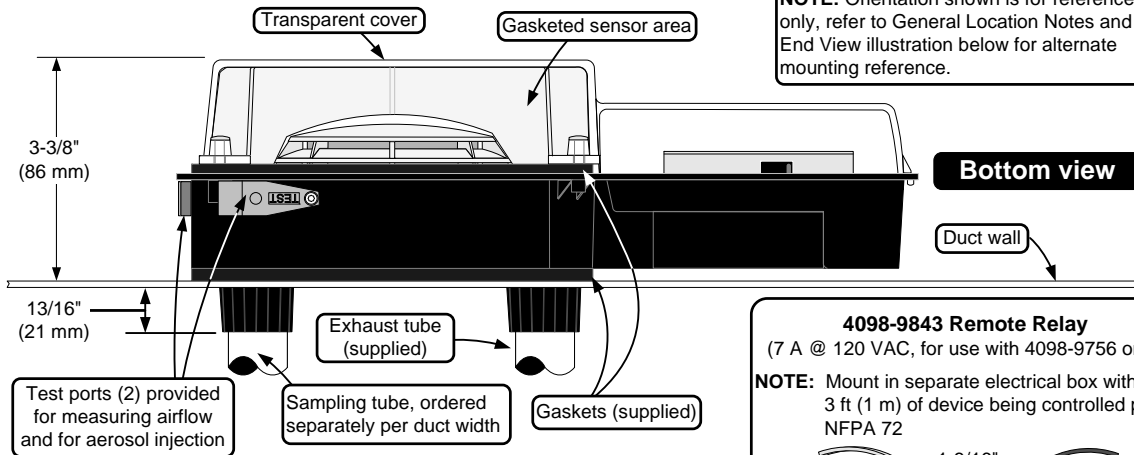

Sampling tube, keyed for proper hole alignment **with holes facing into airflow** (template is provided for proper tube installation). (Housing is shown as position 2 per note 2 below.)

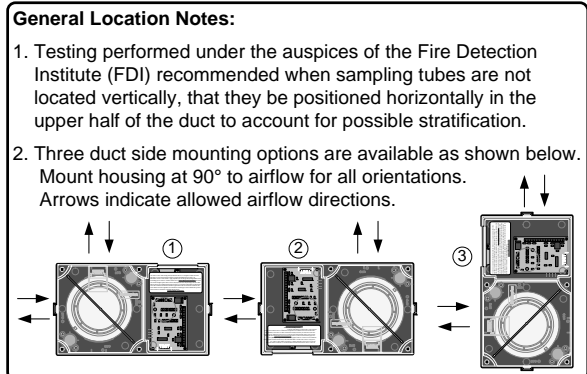
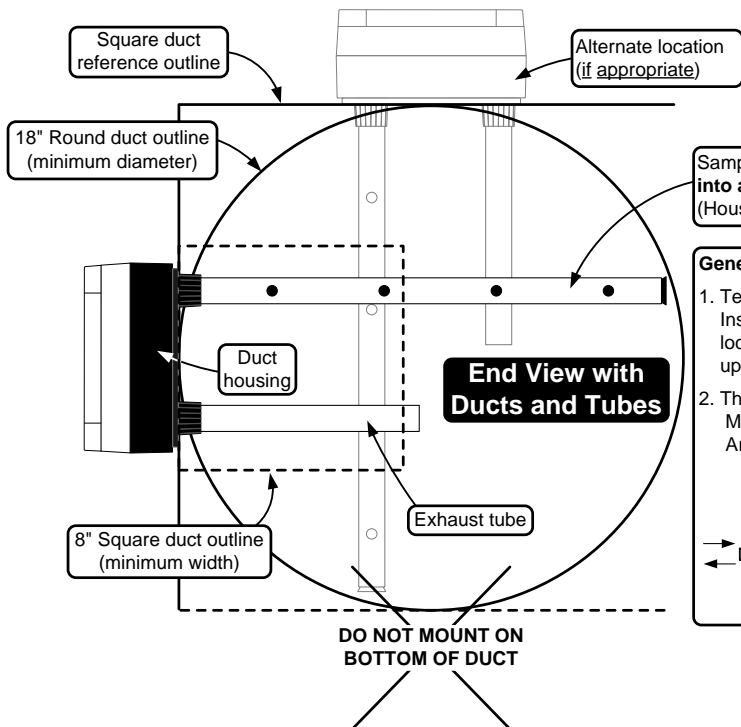

## Duct Sensor Location Reference

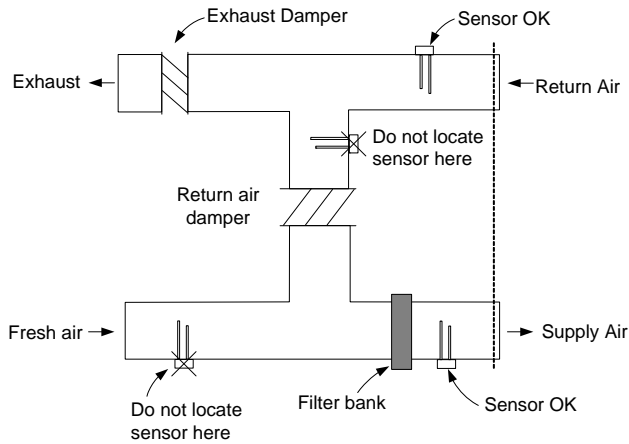

**Additional Information.** Refer to NFPA 90A, *Standard for the Installation of Air Conditioning and Ventilating Systems*; NFPA 72, the *National Fire Alarm and Signaling Code*; and the *NEMA Guide for Proper Use of Smoke Detectors in Duct Applications*, and Installation Instructions 574-776.

## Specifications

### General Mechanical and Environmental

Air Velocity Range (linear ft/min)	300 to 4000 ft/min (91 to 1220 m/min)
Sensor Sensitivity Range	0.2% to 3.7% per foot of obscuration, selectable at host control panel
UL Listed Temperature Range	32° F to 100° F (0° C to 38° C)
Operating Temperature Range	32° F to 122° F (0° C to 50° C)
Storage Temperature Range	0° F to 140° F (-18° C to 60° C)
Humidity Range	10% to 95% RH, non-condensing
Wiring Connections	Terminal blocks, 18 to 12 AWG (0.82 mm <sup>2</sup> to 3.31 mm <sup>2</sup> )
Housing Color and Material	Black ABS base with clear polycarbonate cover
Sampling and Exhaust Tube Material	Black CPVC, custom extrusion; sampling tubes are pre-drilled

### Remote Status/Alarm LED and Test Station with Remote Status/Alarm LED

Remote Alarm LED Current	1.2 mA, no impact to 24 VDC alarm current (2098-9808 or 2098-9806)
Test Station Keyswitch Current	3.3 mA, no impact to 24 VDC alarm current (2098-9806)
Remote Alarm LED and Test Station Distance	250 ft (76 m) maximum

### Addressable Operation

Data Communications	IDNet or MAPNET II communications, auto-select, one address per housing; provides operating power to model 4098-9755
---------------------	--

### Model 4098-9756 with Supervised Multiple Relay Control, Requires Separate Fused 24 VDC from Fire Alarm Power Supply

Input Voltage	18-32 VDC (24 VDC nominal)
Standby Current	3 mA @ 24 VDC
Alarm Current	15 mA @ 24 VDC; add 15 mA for each 4098-9843 relay
Supervised Remote Relay Control Output	For use with 4098-9843 relay only, quantity of 15 maximum; distance of 500 ft (152 m) maximum; requires 4081-9008 (ref. 733-894) 10 k $\Omega$ , 1/2 W end-of-line resistor

### 4098-9843 Relay Output Ratings, Single Form C, use with Model 4098-9756 Only

Coil Current	15 mA @ 24 VDC, up to 15 maximum per relay control output
Relay Contacts	7 A at 0.35 PF @ 28 VDC & 120 VAC; 250 $\mu$ A @ 5 VDC
Location Distance	500 ft (152 m) maximum to relay coils; locate relays within 3 ft (1 m) of device being controlled per NFPA 72

TYCO, SIMPLEX, and the product names listed in this material are marks and/or registered marks. Unauthorized use is strictly prohibited. NFPA 72 and National Fire Alarm and Signaling Code are registered trademarks of the National Fire Protection Association (NFPA).



Tyco Fire Protection Products • Westminister, MA • 01441-0001 • USA

S4098-0030-10 11/2014

[www.simplex-fire.com](http://www.simplex-fire.com)

© 2014 Tyco Fire Protection Products. All rights reserved. All specifications and other information shown were current as of document revision date and are subject to change without notice.

## Duct Sensor Location Considerations:

1. Proper duct smoke detection location must ensure adequate airflow within the duct housing.
2. Duct air velocity rating is 300 to 4000 ft/min (91 to 1220 m/min). Pressure differential between intake and exhaust tubes is required to be between 0.015 to 1.55 inches of water (0.381 to 39.37 mm).
3. Ensure accessibility for test and service.
4. Proper Locations: downstream side of filters to detect fires in the filters; in return ducts, ahead of mixing areas; upstream of air humidifier and cooling coil.
5. Other locations and orientations may be required for proper duct smoke detection depending on duct access, system design, and duct airflow testing. Contact your local Simplex product supplier for assistance.

## Locations to Avoid:

1. Where dampers closed for comfort control would interfere with airflow.
2. Next to outside air inlets (unless the intent is to monitor smoke entry from that area).
3. In return air damper branch ducts and mixing areas where airflow may be restricted.