

NORTHWEST FIRE SYSTEMS



***Saving Lives
Protecting Property***

**22645 83rd Ave. S, Bldg D
Kent, WA 98032**

**Phone: (206)772-7502 Fax: (206)772-7504
License# NORTHFS875MJ**

EQUIPMENT SUBMITTAL

For

ROUND ONE T.I. Buildout

**3500 S. Meridian St.
Puyallup, WA 98373**

NWSF JOB NO. 04970L

Velociti® Series 3 Detectors

Photoelectric Detectors

Description

The Gamewell-FCI, Velociti® Series 3 intelligent photoelectric detectors with integral communication provide point location for alarm communication and selective maintenance. Designed in a modern bright white color, the Velociti Series 3 is aesthetically pleasing for today's contemporary buildings.

The Velociti Series 3 smoke detectors are intelligent addressable detectors with point ID capability that enable each detector address to be set with rotary address switches providing exact device locations. The photoelectric detector continually monitors the detected temperature and reports it to the fire alarm control panel. The modern design and expanded color options support a variety of contemporary aesthetic demands. In addition, each detector is constructed for exceptional installation and maintenance efficiency.

The Gamewell-FCI, ASD-PL3 photoelectric detector's re-designed optical sensing chamber is engineered to sense smoke produced by a wide range of combustion sources in accordance with more stringent code standards. The sensitivity of Velociti series detectors can be programmed using the control panel software to suit the environment. The ASD-PL3R photoelectric detector is also remote test capable that may be used with a DNR (DNRW) duct smoke detector housing. The ASD-PTL3 multi-sensor detector offers either photoelectric detection or thermal detection through dual electronic thermistors at 135°F fixed temperature thermal sensing.

For legacy installations, service detectors are available in the classic ivory color that will operate in both Velociti and CLIP protocol for backwards compatibility. Service models are designated by the -IV part number after the detector model.

Note: Although the E3 Series® and S3 Series panels support both the Velociti® and CLIP™ protocols, the GWF-7075 panel does not support the CLIP protocol. To obtain a complete list of panels that are listed to Velociti Series 3 detectors, refer to the Compatibility Addendum for Gamewell-FCI Manuals, P/N:9000-0427-L8.



Photoelectric Detector

FEATURES & BENEFITS

- Complies with UL® Standard 268 7th Edition
- Contains a built-in functional test switch activated by external magnet
- Provides rotary address switches (01-159)
- Includes dual LEDs for 360° visibility
- Offers expanded color options
- Designed with a new profile to offer modern and improved aesthetics
- Supports a low standby current
- Supplies optional relay, isolator, or sounder bases (standard or low frequency)

Ordering Information

NOTE: "-IV" suffix indicates Ivory color model.

NOTE: "-BL" suffix indicates Black color model.

NOTE: "WH" suffix indicates Bright White color model.

ASD-PL3: Photoelectric smoke detector, bright white, Velociti

ASD-PL3R: Photoelectric smoke detector, remote test capable, for use with DNR(W) duct smoke detectors, bright white, Velociti

ASD-PTL3: Photoelectric smoke detector with thermal sensing, bright white, Velociti

ASD-PL3-IV : Photoelectric smoke detector, ivory, Velociti/CLIP

ASD-PL3R-IV: Photoelectric smoke detector, remote test capable, for use with DNR(W) duct smoke detectors, ivory, Velociti/CLIP

ASD-PTL3-IV : Photoelectric smoke detector with thermal sensing, ivory, Velociti/CLIP

Intelligent Bases

For details on intelligent bases, refer to Data Sheet P/N: 9021-60540.

Note: "IV" suffix indicates Flashscan and CLIP devices. "WH" suffix indicates bright white

B501-WHITE: 4" Flangeless mounting base, bright white

B501-WHITE-BP: 4" Flangeless mounting base bulk pack, bright white

B501-IV: 4" Flangeless mounting base, ivory

B300-6: 6" Flanged mounting base, bright white

B300-6-IV: 6" Flanged mounting base, ivory

B300-6-BP: 6" Flanged mounting base bulk (Pack of 10)

B200SR-WH: Standard sounder base, bright white

B200SR-IV: Standard sounder base, ivory

B200S-WH: Intelligent addressable sounder base, bright white

B200S-IV: Intelligent addressable sounder base, ivory

B200SR-LF-WH: Standard low frequency sounder base, bright white

B200SR-LF-IV: Standard low frequency sounder base, ivory

B200S-LF-WH: Intelligent addressable low frequency sounder base, bright white

B200S-LF-IV: Intelligent addressable low frequency sounder base, ivory

B224RB-WH: Relay base, bright white

B224RB-IV: Relay base, ivory

B224BI-WH: Isolator base, bright white

B224BI-IV: Isolator base, ivory

DNR: Intelligent duct detector housing, non-relay

DNRW: Intelligent duct detector housing, non-relay, watertight

Ordering Information

Accessories

SMB600: Surface Mounting Kit (flanged)

TR300: Accessory Flange Ring for B300 6" Base, bright white

TR300-IV: Accessory Flange Ring for B300 6" Base, ivory

RA100Z: Remote LED annunciator, 3-32 VDC

The annunciator mounts to a U.S. single-gang electrical box. For use with B501 and B300-6.

CK300: Bright White detector kit (Pack of 10)

CK300-IR: White, detector color kit for use with MCS-COF Series Detectors. (Pack of 10)

CK300-IV: Ivory, detector color kit. (Pack of 10)

CK300-IR-IV: Ivory, detector color kit for use with MCS-COF Series detectors. (Pack of 10)

CK300-BL: Black detector kit. (Pack of 10)

CK300-IR-BI: Black, detector color kit for use with MCS-COF Series detectors. (Pack of 10)

M02-04-01: Detector test magnet.

M02-09-00: Test magnet with telescoping handle.

XR2B: Detector removal tool. Allows the installation and/or removal of the detector heads from the bases in high ceiling applications.

XP-4: Extension pole for XR2B. Shipped with three, 5-foot (1.524,m) sections.

Velociti® Series 3 Detectors Technical Specifications

SYSTEMS

Photoelectric Intelligent Detector:

Physical Specifications

Height: 2.0 inches (51 mm) installed in B300-6 base

Diameter:

6.1 inches (15.49 cm) installed in B300-6 base

4 inches (10.16 cm) installed in B501 base

Shipping Weight: 3.4 oz (96.4 g)

Operating Temperature Range:

Photo: 32° F to 122° F (0° C to 50° C)

Photo in Duct Applications: -4° F to 158° F
(-20° C to 70° C)

Photo with Thermal: 32° F to 100° F (0° C to 38° C)

Operating Humidity Range: 10% to 93%
non-condensing

Rate-of-Rise Detection: Responds to greater than
15°F/minute or 135°F (8.3° C/minute or 57°C)

Air Velocity Range: 0 to 4,000 ft/min
(0 to 1219.2 m/min)

Electrical Specifications

Voltage Range: 15 to 32 VDC

Standby Current (@ 24 VDC): 200 UA (one
communication every 5 seconds with green LED
enabled)

Max Alarm Current (max.): 2 mA @ 24 VDC (one
communication every 5 seconds with red LED
enabled)

Max Current (max.): 4.5 mA @ 24 VDC (one
communication every 5 seconds with amber LED
enabled)

Isolator Load Rating: 0.0063

STANDARDS

The Velociti® Series 3 Photoelectric Detectors are designed to comply with the following standard:

UL Standard: UL 268

AGENCY LISTINGS AND APPROVALS

These listings and approvals apply to the modules specified in this document. In some cases, certain modules or applications may not be listed by certain approval agencies, or listing may be in process. Consult factory for latest listing status.

UL: S2332

FM: 3023594

MEA FDNY: COA-219-02-E Vol. VI

CSFM: 7272-1703:0501

ISO 9001 Certification

For a complete listing of all compliance approvals and certifications, please visit:
<http://www.gamewell-fci.com/en-US/documentation/Pages/Listings.aspx>

E3 Series®, Velociti® and Gamewell-FCI® are registered trademarks of Honeywell International Inc.

UL® is a registered trademark of Underwriter's Laboratories Inc.

This document is not intended to be used for installation purposes. We try to keep our product information up-to-date and accurate. We cannot cover all specific applications or anticipate all requirements. All specifications are subject to change without notice.

For more information

Learn more about Gamewell-FCI's Velociti® Series 3 Detectors and other products available by visiting www.Gamewell-FCI.com

Honeywell Gamewell-FCI

12 Clintonville Road
Northford, CT 06472-1610
203.484.7161
www.honeywell.com

9020-0617 | K | 04/2018
©2018 Honeywell International Inc.

Honeywell

Velociti® Series 3 Detectors

Thermal Detectors

Description

The Gamewell-FCI, Velociti® Series 3 intelligent thermal detectors with integral communication provide point location for alarm communication and selective maintenance. Designed in a modern bright white color, the Velociti Series 3 is aesthetically pleasing for today's contemporary buildings.

The Velociti Series 3 heat detectors are intelligent addressable detectors with point ID capability that enable each detector address to be set with rotary address switches providing exact device locations. The thermal detector continually monitors the detected temperature and reports it to the fire alarm control panel. The modern design and expanded color options support a variety of contemporary aesthetic demands. In addition, each detector is constructed for exceptional installation and maintenance efficiency. Velociti Series 3 thermal detectors provide cost-effective, intelligent property protection using the following single thermistor:

- ATD-L3 offers 135°F fixed thermal detection.
- ATD-L3R offers 135°F fixed and rate-of-rise thermal detection.
- ATD-L3H provides fixed high-temperature detection at 190°F.

For legacy installations, service detectors are available in the classic ivory color that will operate in both Velociti and CLIP protocol for backwards compatibility. Service models are designated by the -IV part number that appears after the detector model.

Note: The E3 Series® and S3 Series panels support both the Velociti® and CLIP™ protocols, and the GWF-7075 panel supports only the Velociti® protocol. To obtain a complete list of panels that are listed to Velociti Series 3 detectors, refer to the Compatibility Addendum for Gamewell-FCI Manuals, P/N:9000-0427-L8.



Thermal Detector

FEATURES & BENEFITS

- Complies with UL® 268 7th Edition
- Contains a built-in functional test switch activated by an external magnet
- Provides rotary address switches (01-159)
- Includes dual LEDs used for 360° visibility
- Offers expanded color options
- Designed with a new profile to offer modern and improved aesthetics
- Supports a low standby current
- Supplies optional relay, isolator, or sounder bases (standard or low frequency)

Ordering Information

NOTE: "-IV" suffix indicates Ivory color model.

NOTE: "-BL" suffix indicates Black color model.

NOTE: "WH" suffix indicates Bright White color model.

ATD-L3: Thermal heat detector, 135°F fixed, bright white, Velociti

ATD-L3-IV: Thermal heat detector, 135°F fixed, ivory, Velociti/CLIP

ATD-L3R: Thermal heat detector, 135°F rate of rise, bright white, Velociti

ATD-L3R-IV: Thermal heat detector, 135°F rate of rise, ivory, Velociti/CLIP

ATD-L3H: Thermal heat detector, 190°F high temp, bright white, Velociti

ATD-L3H-IV: Thermal heat detector, 190°F high temp, ivory, Velociti/CLIP

Intelligent Bases

For details on intelligent bases, refer to Data Sheet P/N: 9021-60540.

B501-White: 4" Flangeless mounting base, bright white

B501-White-BP: 4" Flangeless mounting base bulk pack, bright white

B501-IV: 4" Flangeless mounting base, ivory
B501-BL

4" Flangeless mounting base,

B300-6: 6" Flanged mounting base, bright white

B300-6-IV: 6" Flanged mounting base, ivory

B300-6-BP: 6" Flanged mounting base bulk pack

B200SR-WH: Standard sounder base, bright white

B200SR-IV: Standard sounder base, ivory

B200S-WH: Intelligent addressable sounder base, bright white

B200S-IV: Intelligent addressable sounder base, ivory

B200SR-LF-WH: Standard low frequency sounder base, bright white

B200SR-LF-IV: Standard low frequency sounder base, ivory

B200S-LF-WH: Intelligent addressable low frequency sounder base, bright white

B200S-LF-IV: Intelligent addressable low frequency sounder base, ivory

B224RB-WH: Relay base, bright white

B224RB-IV: Relay base, ivory

B224BI-WH: Isolator base, bright white

B224BI-IV: Isolator base, ivory

Ordering Information

Accessories

SMB600: Surface Mounting Kit (flanged)

TR300: Accessory Flange Ring for B300 6" Base, bright white

TR300-IV: Accessory Flange Ring for B300 6" Base, ivory

RA100Z: Remote LED annunciator, 3-32 VDC

The annunciator mounts to a U.S. single-gang electrical box. For use with B501 and B300-6.

CK300: Bright White detector kit (Pack of 10)

CK300-IR: White, detector color kit for use with MCS-COF Series Detectors. (Pack of 10)

CK300-IV: Ivory, detector color kit. (Pack of 10)

CK300-IR-IV: Ivory, detector color kit for use with MCS-COF Series detectors. (Pack of 10)

CK300-BL: Black detector kit (Pack of 10)

CK300-IR-BL: Black, detector color kit for use with MCS-COF Series detectors. (Pack of 10)

M02-04-01: Detector test magnet.

M02-09-00: Test magnet with telescoping handle.

XR2B: Detector removal tool. Allows the installation and/or removal of the detector heads from the bases in high ceiling applications.

XP-4: Extension pole for XR2B. Shipped with three, 5-foot (1.524,m) sections.

Velociti® Series 3 Detectors Technical Specifications

SYSTEMS

Thermal Intelligent Detector

Physical Specifications

Height: 2.0 inches (51 mm) installed in B300-6 base

Diameter:

6.1 inches (15.6 cm) installed in B300-6 base

4 inches (10.2 cm) installed in B501 base

Shipping Weight: 3.4 oz (95 g)

Operating Temperature Range:

Thermal 135° F fixed: -4° F to 100° F
(-20° C to 38° C)

Thermal 135° F rate-of-rise: -4° F to 100° F
(-20° C to 38° C)

Thermal 190° F rate-of-rise: -4° F to 135° F
(-20° C to 57° C)

Operating Humidity Range: 10% to 93% non-condensing

Rate-of-Rise Detection: : Responds to greater than 15°F/minute or 135°F (8.3° C/minute or 57°C)

Electrical Specifications

Voltage Range: : 15 to 32 VDC

Standby Current (@ 24 VDC): 200 uA (one communication every 5 seconds with green LED enabled)

Max Alarm Current (max.): : 2 mA @ 24 VDC (one communication every 5 seconds with red LED enabled)

Max Current (max.): : 4.5 mA @ 24 VDC (one communication every 5 seconds with amber LED enabled)

Isolator Load Rating: : 0.0063

STANDARDS

The Velociti® Series 3 Thermal Detectors are designed to comply with the following standard:

UL Standard: UL 268

AGENCY LISTINGS AND APPROVALS

These listings and approvals apply to the modules specified in this document. In some cases, certain modules or applications may not be listed by certain approval agencies, or listing may be in process. Consult factory for latest listing status.

UL: S2332

FM: 3023594

MEA-FDNY: 219-02-E Vol. VI

CSFM: 7270-1703-0502

ISO 9001 Certification

For a complete listing of all compliance approvals and certifications, please visit: <http://www.gamewell-fci.com/en-US/documentation/Pages/Listings.aspx>

E3 Series®, Velociti® and Gamewell-FCI® are registered trademarks and CLIP™ is a trademark of Honeywell International Inc.

UL® is a registered trademark of Underwriter's Laboratories Inc.

This document is not intended to be used for installation purposes. We try to keep our product information up-to-date and accurate. We cannot cover all specific applications or anticipate all requirements. All specifications are subject to change without notice.

For more information

Learn more about Gamewell-FCI's Velociti® Series 3 Detectors and other products available by visiting www.Gamewell-FCI.com

Honeywell Gamewell-FCI

12 Clintonville Road
Northford, CT 06472-1610
203.484.7161
www.honeywell.com

9020-0620 | G | 04/2018
©2018 Honeywell International Inc.

Honeywell



Indoor Selectable-Output Speaker Strobes and Dual Voltage Evacuation Speakers for Ceiling Applications

System Sensor L-Series selectable-output speaker strobes and dual-voltage evacuation speakers can reduce ground faults and enable faster installation with lower current draw and modern aesthetics.

Features

- Plug-in design and protective cover reduce ground faults
- Universal mounting plate with an onboard shorting spring tests wiring continuity before installation
- No extension ring required
- Field selectable candela settings on ceiling units: 15, 30, 75, 95, 115, 150, and 177
- Automatic selection of 12- or 24-volt operation at 15 and 30 candela
- Rotary switch simplifies field selection of speaker voltage (25 and 70.7 Vrms) and power settings (¼, ½, 1 and 2 watts)
- Speakers offer high fidelity and high volume sound output
- 520 Hz +/- 10% square wave tone capable with compatible FACP
- Compatible with System Sensor synchronization protocol
- Electrical compatibility with existing SpectrAlert and SpectrAlert Advance products
- Tamper-resistant construction
- Updated modern aesthetics

Agency Listings



System Sensor L-Series of speakers and speaker strobes reduce costly ground faults using a plug-in design and universal mounting plate that allow the installer to pre-wire mounting plates, dress the wires, and confirm wiring continuity before plugging in the speakers. In addition, a protective plastic cover prevents nicked wires by covering exposed speaker components.

These devices also enable faster installations by providing instant feedback to ensure that wiring is properly connected, rotary switches to select voltage and power settings, and 7 field-selectable candela settings for both wall and ceiling speaker strobes.

The low total harmonic distortion of the SP speaker offers high fidelity sound output while still offering high volume sound output for use in high ambient noise applications.

L-Series makes installation easy

- Attach a universal mounting plate to a 4 × 4 × 2¹/₈ inch back box . Flush-mount applications do not require an extension ring.
- Connect the notification appliance circuit or speaker wiring to the terminals on the mounting plate.
- Attach the speaker or speaker strobe to the mounting plate by inserting the product tabs into the mounting plate grooves. Hinge the device into position to lock the product pins into the mounting plate terminals. The device will temporarily hold in place with a catch until it is secured with a captured mounting screw.

L-Series Speaker and Speaker Strobe Specifications

Architectural/Engineering Specifications

General

L-Series speaker and speaker strobes shall mount to a 4 × 4 × 2¹/₈-inch back box. A universal mounting plate shall be used for mounting ceiling and wall products. The notification appliance circuit and amplifier wiring shall terminate at the universal mounting plate. Also, L-Series speaker strobes, when used with the Sync•Circuit™ Module accessory, shall be powered from a non-coded notification appliance circuit output and shall operate on a nominal 12 or 24 volts. When used with the Sync•Circuit Module, 12-volt rated notification appliance circuit outputs shall operate between 8.5 and 17.5 volts; 24-volt rated notification appliance circuit outputs shall operate between 16.5 and 33 volts. Indoor L-Series products shall operate between 32°F and 120°F from a regulated DC, or full-wave rectified, unfiltered power supply. Speaker strobes shall have field-selectable candela settings including 15, 30, 75, 95, 115, 150, 177.

Speaker

The speaker shall be a System Sensor L-Series model _____ dual-voltage transformer speaker capable of operating at 25.0 or 70.7 nominal Vrms. It should be listed to UL 1480 and shall be approved for fire protective service. The speaker shall have a frequency range of 400 to 4,000 Hz and shall have an operating temperature between 32°F and 120°F. The speaker shall have power taps and voltage that are selected by rotary switches.

Speaker Strobe combination

The speaker strobe shall be a System Sensor L-Series model _____ listed to UL1480 and UL 1971 and be approved for fire protective signaling systems. The speaker shall be capable of operating at 25.0 or 70.7 nominal Vrms selected via rotary switch, and shall have a frequency range of 400 to 4,000 Hz. The speaker shall have power taps that are selected by rotary switch. The strobe shall comply with the NFPA 72 requirements for visible signaling appliances, flashing at 1 Hz over the strobe's entire operating voltage range. The strobe light shall consist of a xenon flash tube and associated lens/reflector system.

Synchronization Module

The module shall be a System Sensor Sync•Circuit model MDL3 listed to UL 464 and shall be approved for fire protective service. The module shall synchronize SpectrAlert strobes at 1 Hz. The module shall mount to a 4¹¹/₁₆ × 4¹¹/₁₆ × 2¹/₈-inch back box. The module shall also control two Style Y (class B) circuits or one Style Z (class A) circuit. The module shall synchronize multiple zones. Daisy chaining two or more synchronization modules together will synchronize all the zones they control. The module shall not operate on a coded power supply.

Physical Specifications

Operating Temperature	32°F to 120°F (0°C to 49°C)	
Humidity Range	10 to 93% non-condensing	
Dimensions, Ceiling-Mount	Diameter	Depth
SPC Speaker	6.8 in, 173 mm	1.0 in, 25 mm
With Surface Mount Back Box	6.9 in, 176 mm	3.5 in, 89 mm
SPSC Speaker Strobe	6.8 in, 173 mm	2.8 in, 73 mm
With Surface Mount Back Box	6.9 in, 176 mm	5.37 in, 136 mm

*When using 12AWG, 14 AWG, or adding extra wires in the box, a deeper box or extension ring is recommended.

Electrical/Operating Specifications

Nominal Voltage (speakers)	25 Volts or 70.7 Volts (nominal)
Maximum Supervisory Voltage (speakers)	50 VDC
Strobe Flash Rate	1 flash per second
Nominal Voltage (strobes)	Regulated 12 VDC or regulated 24 VDC/FWR ^{1,2}
Operating Voltage Range (includes fire alarm panels with built in sync)	8 to 17.5 V (12 V nominal) or 16 to 33 V (24 V nominal)
Operating Voltage with MDL3 Sync Module	8.5 to 17.5 V (12 V nominal) or 16.5 to 33 V (24 V nominal)
Frequency Range	400 to 4,000 Hz ³
Power	¼, ½, 1, 2 watts

1. Full Wave Rectified (FWR) voltage is a non-regulated, time-varying power source that is used on some power supply and panel outputs.
2. Strobe products will operate at 12 V nominal only for 15 and 30 cd.
3. 520 Hz +/- 10% square wave tone capable with compatible FACP.

UL Current Draw Data

UL Max. Strobe Current Draw (mA RMS)			
	8 to 17.5 Volts	16 to 33 Volts	
Candela	DC	DC	FWR
15	87	41	60
30	153	63	86
75	NA	111	142
95	NA	134	164
115	NA	158	191
150	NA	189	228
177	NA	226	264

Ceiling-Mount Speaker Sound Output		
Setting	UL Reverberant (dBA @ 10 ft)	UL Anechoic (dBA @ 10 ft)
1/4 W	79	79
1/2 W	82	82
1 W	85	85
2 W	88	88

Ceiling-Mount Speaker Strobe Sound Output		
Setting	UL Reverberant (dBA @ 10 ft)	UL Anechoic (dBA @ 10 ft)
1/4 W	77	77
1/2 W	80	80
1 W	83	83
2 W	86	86

L-Series Dimensions

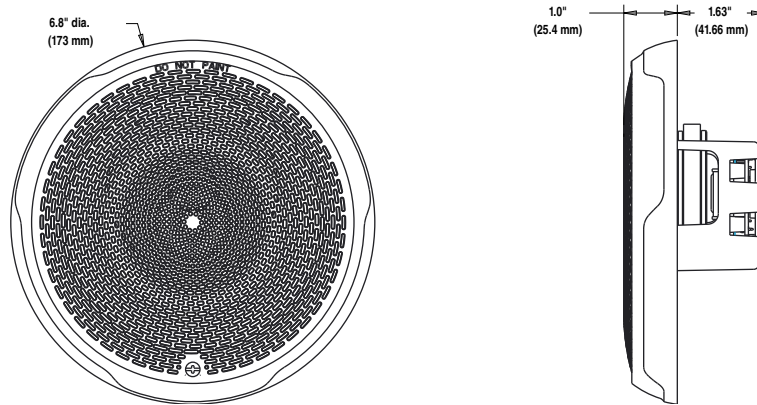

Ceiling Speaker

A0543-00

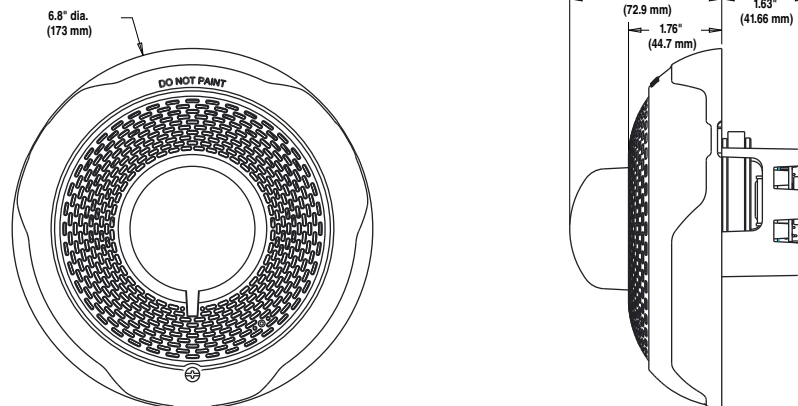

Ceiling Speaker Strobe

A0544-00

Surface Mounting

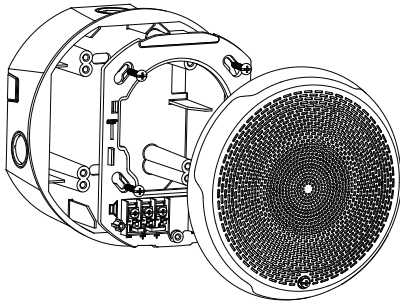

A0504-01

Ceiling Speaker with Surface Mount Back Box

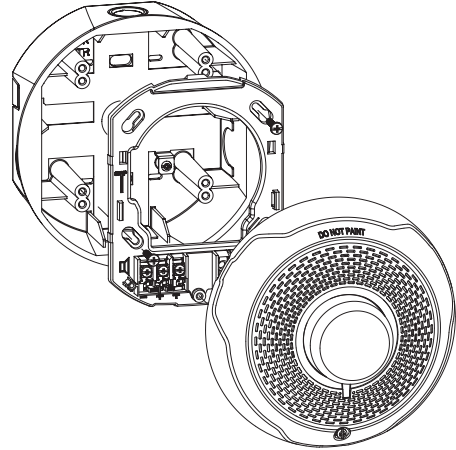

A0520-01

Ceiling Speaker Strobe with Surface Mount Back Box

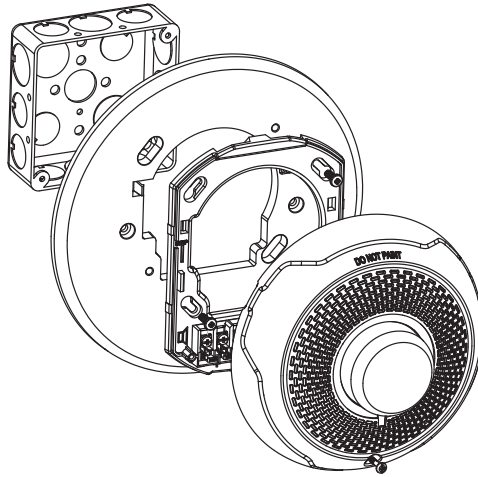

A0542-00

Ceiling Speaker Strobe with Trim Ring and 4" Square Electrical Box

L-Series Ordering Information

Ceiling Mount		
White	Red	Description
SPCWL	SPCRL	Speaker only
SPSCWL	SPSCRL	Speaker Strobe
SPSCWL-P	—	Plain, Speaker Strobe
SPSCWL-SP	—	Fuego, Speaker Strobe
SPSCWL-CLR-ALERT	—	Alert, Speaker Strobe, Clear Lens

Accessories		
White	Red	Description
SBBCWL	SBBCRL	Universal Ceiling Surface Mount Back Box
TRC-2W	TRC-2	Universal Ceiling Trim Ring



3825 Ohio Avenue • St. Charles, IL 60174
 Phone: 800-SENSOR2 • Fax: 630-377-6495
www.systemsensor.com

©2018 System Sensor.
 Product specifications subject to change without notice. Visit systemsensor.com
 for current product information, including the latest version of this data sheet.
 AVDS866-03 • 03/23/2018



Indoor Selectable-Output Strobes and Horn Strobes for Ceiling Applications

System Sensor L-Series audible visible notification products are rich with features guaranteed to cut installation times and maximize profits with lower current draw and modern aesthetics.



Features

- Plug-in design with minimal intrusion into the back box
- Tamper-resistant construction
- Automatic selection of 12- or 24-volt operation at 15 and 30 candela
- Field-selectable candela settings on ceiling units: 15, 30, 75, 95, 115, 150, and 177
- Horn rated at 88+ dBA at 16 volts
- Rotary switch for horn tone and two volume selections
- Universal mounting plate for ceiling units
- Mounting plate shorting spring feature checks wiring continuity before device installation
- Electrically Compatible with legacy SpectrAlert and SpectrAlert Advance devices
- Compatible with MDL3 sync module
- Listed for ceiling mounting only

The System Sensor L-Series offers the most versatile and easy-to-use line of horns, strobes, and horn strobes in the industry with lower current draws and modern aesthetics. With white and red plastic housings, wall and ceiling mounting options, System Sensor L-Series can meet virtually any application requirement.

The entire L-Series product line of ceiling-mount strobes and horn strobes include a variety of features that increase their application versatility while simplifying installation. All devices feature a plug-in design with minimal intrusion into the back box, making installations fast and foolproof while virtually eliminating costly and time-consuming ground faults.

To further simplify installation, the L-Series utilizes a universal mounting plate so installers can mount them to a wide array of back boxes. With an onboard shorting spring, installers can test wiring continuity before the device is installed.

Installers can also easily adapt devices to a suit a wide range of application requirements using field-selectable candela settings, automatic selection of 12- or 24-volt operation, and a rotary switch for horn tones with two volume selections.

Agency Listings



S5512
S4011



FM approved except
for ALERT models
3057383



7125-1653:0504
7135-1653:0503

L-Series Specifications

Architect/Engineer Specifications

General

L-Series ceiling-mount strobes and horn strobes shall mount to a standard 4 × 4 × 1½-inch back box, 4-inch octagon back box, or double-gang back box. Two-wire products shall also mount to a single-gang 2 × 4 × 17/8-inch back box. A universal mounting plate shall be used for mounting ceiling and wall products. The notification appliance circuit wiring shall terminate at the universal mounting plate. Also, L-Series products, when used with the Sync•Circuit™ Module accessory, shall be powered from a non-coded notification appliance circuit output and shall operate on a nominal 12 or 24 volts. When used with the Sync•Circuit Module, 12-volt-rated notification appliance circuit outputs shall operate between 8.5 and 17.5 volts; 24-volt-rated notification appliance circuit outputs shall operate between 16.5 and 33 volts. Indoor L-Series products shall operate between 32 and 120 degrees Fahrenheit from a regulated DC or full-wave rectified unfiltered power supply. Ceiling strobes and horn strobes shall have field-selectable candela settings including 15, 30, 75, 95, 115, 150, and 177.

Strobe

The strobe shall be a System Sensor L-Series Model _____ listed to UL 1971 and shall be approved for fire protective service. The strobe shall be wired as a primary-signaling notification appliance and comply with the Americans with Disabilities Act requirements for visible signaling appliances, flashing at 1 Hz over the strobe's entire operating voltage range. The strobe light shall consist of a xenon flash tube and associated lens/reflector system.

Horn Strobe Combination

The horn strobe shall be a System Sensor L-Series Model _____ listed to UL 1971 and UL 464 and shall be approved for fire protective service. The horn strobe shall be wired as a primary-signaling notification appliance and comply with the Americans with Disabilities Act requirements for visible signaling appliances, flashing at 1 Hz over the strobe's entire operating voltage range. The strobe light shall consist of a xenon flash tube and associated lens/reflector system. The horn shall have two audibility options and an option to switch between a temporal three pattern and a non-temporal (continuous) pattern. These options are set by a multiple position switch. The horn on horn strobe models shall operate on a coded or non-coded power supply.

Synchronization Module

The module shall be a System Sensor Sync•Circuit model MDL3 listed to UL 464 and shall be approved for fire protective service. The module shall synchronize L-Series strobes at 1 Hz and horns at temporal three. Also, while operating the strobes, the module shall silence the horns on horn strobe models over a single pair of wires. The module shall mount to a 4 11/16 × 4 11/16 × 2 1/8-inch back box. The module shall also control two Style Y (class B) circuits or one Style Z (class A) circuit. The module shall synchronize multiple zones. Daisy chaining two or more synchronization modules together will synchronize all the zones they control. The module shall not operate on a coded power supply.

Physical/Electrical Specifications

Standard Operating Temperature	32°F to 120°F (0°C to 49°C)
Humidity Range	10 to 93% non-condensing
Strobe Flash Rate	1 flash per second
Nominal Voltage	Regulated 12 VDC or regulated 24 DC/FWR ¹
Operating Voltage Range²	8 to 17.5 V (12 V nominal) or 16 to 33 V (24 V nominal)
Operating Voltage Range (MDL3)	8.5 to 17.5V (12 V nominal) or 16.5 to 33 V (24V nominal)
Input Terminal Wire Gauge	12 to 18 AWG
Ceiling-Mount Dimensions (including lens)	6.8" diameter × 2.5" high (173 mm diameter × 64 mm high)
Ceiling-Mount Surface Mount Back Box Skirt Dimensions (SBBCRL, SBBCWL)	6.9" diameter × 3.4" high (175 mm diameter × 86 mm high)

Notes:

1. Full Wave Rectified (FWR) voltage is a non-regulated, time-varying power source that is used on some power supply and panel outputs.
2. P, S, PC, and SC products will operate at 12 V nominal only for 15 and 30 cd.

UL Current Draw Data

UL Max. Strobe Current Draw (mA RMS)				
Candela Range	Candela	8–17.5 Volts		16–33 Volts
		DC	DC	FWR
Candela Range	15	87	41	60
	30	153	63	86
	75	N/A	111	142
	95	N/A	134	164
	115	N/A	158	191
	150	N/A	189	228
	177	N/A	226	264

UL Max. Horn Current Draw (mA RMS)				
Sound Pattern	dB	8–17.5 Volts		16–33 Volts
		DC	DC	FWR
Temporal	High	39	44	54
Temporal	Low	28	32	54
Non-Temporal	High	43	47	54
Non-Temporal	Low	29	32	54
3.1 KHz Temporal	High	39	41	54
3.1 KHz Temporal	Low	29	32	54
3.1 KHz Non-Temporal	High	42	43	54
3.1 KHz Non-Temporal	Low	28	29	54
Coded	High	43	47	54
3.1 KHz Coded	High	42	43	54

UL Max. Current Draw (mA RMS), Ceiling Horn Strobe, Candela Range (15–177 cd)										
DC Input	8–17.5 Volts		16–33 Volts							
	15cd	30cd	15cd	30cd	75cd	95cd	115cd	150cd	177cd	
Temporal High	103	167	71	90	143	165	187	217	254	
Temporal Low	96	165	54	71	137	161	185	211	249	
Non-Temporal High	106	173	71	90	141	165	187	230	273	
Non-Temporal Low	95	166	54	71	124	161	170	216	258	
3.1K Temporal High	111	164	69	94	147	163	184	229	257	
3.1K Temporal Low	103	163	54	88	143	155	185	212	252	
3.1K Non-Temporal High	111	172	69	94	144	164	202	229	271	
3.1K Non-Temporal Low	103	169	54	88	131	155	187	217	259	
FWR Input	16–33 Volts									
	15cd	30cd	75cd	95cd	115cd	150cd	177cd			
Temporal High	107	135	179	198	223	254	286			
Temporal Low	78	101	151	172	199	229	262			
Non-Temporal High	107	135	179	198	223	254	286			
Non-Temporal Low	78	101	151	172	199	229	262			
3.1K Temporal High	108	135	179	200	225	255	289			
3.1K Temporal Low	79	101	150	171	196	229	260			
3.1K Non-Temporal High	108	135	179	200	225	255	289			
3.1K Non-Temporal Low	79	101	150	171	196	229	260			

Horn Strobe Tones and Sound Output Data

Horn Strobe Output (dBA)					
Switch Position	Sound Pattern	dB	8–17.5 Volts	16–33 Volts	FWR
			DC	DC	
1	Temporal	High	84	89	89
2	Temporal	Low	75	83	83
3	Non-Temporal	High	85	90	90
4	Non-Temporal	Low	76	84	84
5	3.1 KHz Temporal	High	83	88	88
6	3.1 KHz Temporal	Low	76	82	82
7	3.1 KHz Non-Temporal	High	84	89	89
8	3.1 KHz Non-Temporal	Low	77	83	83

L-Series Dimensions

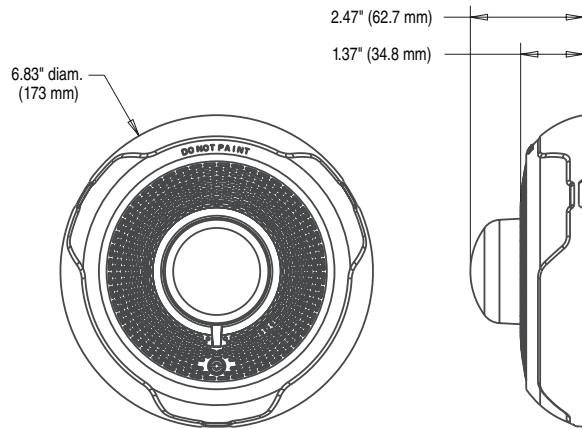

Ceiling-Mount Horn Strobes

A0545-00

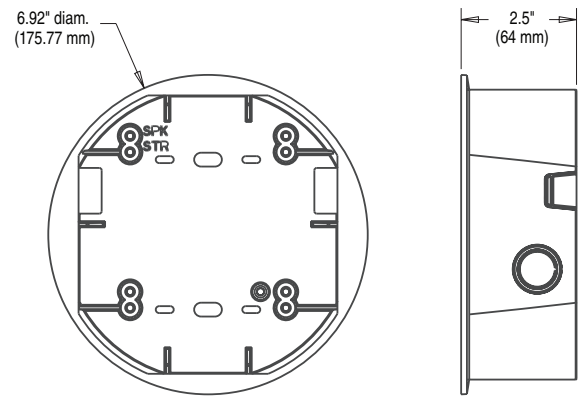

Ceiling Surface Mount Back Box

A0546-00

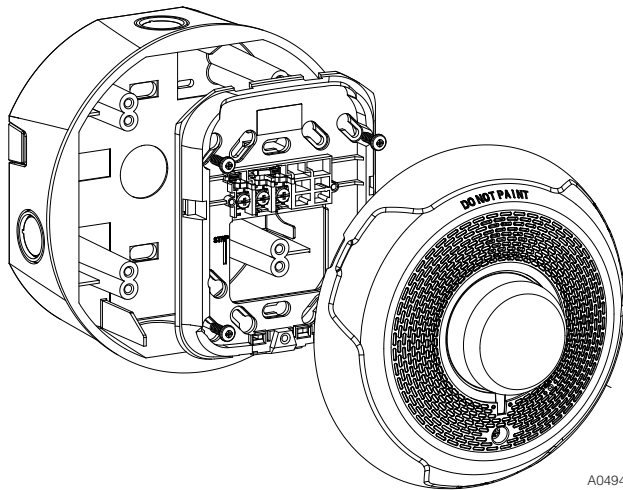

**2-Wire Ceiling Mount Horn Strobes
with Ceiling Surface Mount Back Box**

A0494-01

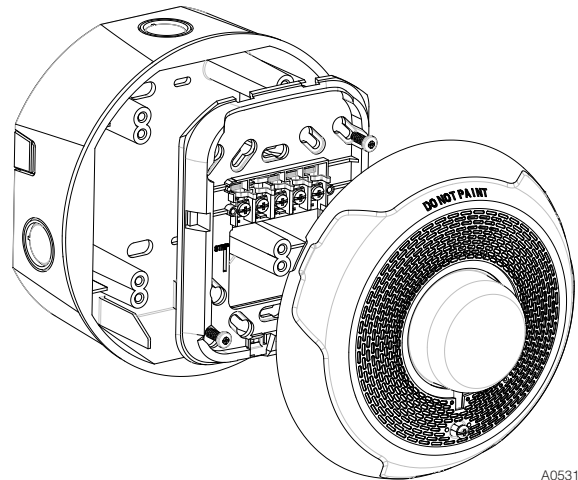

**4-Wire Ceiling Mount Horn Strobes
with Ceiling Surface Mount Back Box**

A0531-01

L-Series Ordering Information

Model	Description
Ceiling Horn Strobes	
PC2RL	2-Wire, Horn Strobe, Red
PC2WL	2-Wire, Horn Strobe, White
PC4RL	4-Wire, Horn Strobe, Red
PC4WL	4-Wire, Horn Strobe, White

Model	Description
Ceiling Strobes	
SCRL	Strobe, Red
SCWL	Strobe, White
SCWL-CLR-ALERT	Strobe, White, ALERT
Accessories	
TRC-2	Universal Ceiling Trim Ring Red
TRC-2W	Universal Ceiling Trim Ring White
SBBCRL	Ceiling Surface Mount Back Box, Red
SBBCWL	Ceiling Surface Mount Back Box, White

For a ceiling-listed horn-only device, see AVDS865 "Indoor Selectable-Output Horns, Strobes, and Horn Strobes for Wall Applications".



3825 Ohio Avenue • St. Charles, IL 60174
Phone: 800-SENSOR2 • Fax: 630-377-6495

©2017 System Sensor.
Product specifications subject to change without notice. Visit systemsensor.com
for current product information, including the latest version of this data sheet.
AVDS868-02 • 12/01/2017



Outdoor, Selectable-Output Speaker Strobes and Dual-Voltage Evacuation Speakers for Wall Applications

SpectrAlert® Advance outdoor, selectable-output speaker strobes and dual-voltage evacuation speakers meet virtually any outdoor application requirement.

Features

- Weatherproof per NEMA 4X, IP56
- Rated from -40°F to 151°F
- Plug-in design reduces ground faults
- Universal mounting plate with onboard shorting spring that tests wiring continuity before devices are installed
- Field-selectable candela settings: 15, 15/75, 30, 75, 95, 110, 115, 135, 150, 177, and 185
- Automatic selection of 12- or 24-volt operation at 15 and 15/75 candela
- Rotary switch for speaker voltage (25 and 70.7 Vrms) and power settings (1/4, 1/2, 1 and 2 watts)
- Compatible with System Sensor synchronization protocol and legacy SpectrAlert products
- Tamper-resistant construction
- Listed for ceiling or wall mounting

Agency Listings



SpectrAlert Advance offers the broadest line of outdoor speakers and speaker strobes in the industry. From metal and plastic outdoor back boxes, to white and red plastic housings, to wall and ceiling mounting options, SpectrAlert Advance can meet virtually any application requirement.

Wall-mount outdoor speakers and speaker strobes can be used indoors or outdoors in wet or dry applications, and can provide reliable operation from -40°F to 151°F. These speakers provide a broad frequency response range, low harmonic distortion and maintain a high sound pressure level at all tap settings to provide accurate and intelligible broadcast of evacuation messages.

Like the entire SpectrAlert Advance line, wall-mount outdoor speakers and speaker strobes include a variety of features that increase application flexibility and simplify installation. First, field-selectable settings, including candela, speaker voltage and power settings, and automatic selection of 12- or 24-volt operation enable installers to easily adapt devices to meet requirements.

Next, these devices use a universal mounting plate with an onboard shorting spring that ensures wiring continuity before devices are installed, so installers can verify proper wiring without mounting the devices and exposing them to potential construction damage. Once the plates are mounted, all SpectrAlert Advance devices utilize a plug-in design with a single captured screw to speed installation and virtually eliminate costly ground faults.

Outdoor devices ship with weatherproof plastic back boxes (metal back boxes are available separately) that accommodate in-and-out wiring for daisy chaining devices. Plastic back boxes feature removable side flanges and improved resistance to saltwater corrosion. Knock-outs located on the back eliminate the need to drill holes for screw-in mounting. Plastic and metal weatherproof back boxes come with 3/4-inch top and bottom conduit entries and 3/4-inch knock-outs at the back. A screw-in NPT plug with an O-ring gasket for a watertight seal is included with each back box.

SpectrAlert® Advance Outdoor Speaker and Speaker Strobe Specifications

Architectural/Engineering Specifications

General

SpectrAlert Advance outdoor speakers and speaker strobes shall mount to a weatherproof back box. A universal mounting plate shall be used for mounting ceiling and wall products. The notification appliance circuit and amplifier wiring shall terminate at the universal mounting plate. Also, SpectrAlert Advance speaker strobes, when used with the Sync•Circuit™ Module accessory, shall be powered from a non-coded notification appliance circuit output and shall operate on a nominal 12 or 24 volts. When used with the Sync•Circuit Module, 12-volt-rated notification appliance circuit outputs shall operate between 8.5 and 17.5 volts; 24-volt-rated notification appliance circuit outputs shall operate between 16.5 and 33 volts. Outdoor SpectrAlert Advance products shall operate between –40°F and 151°F from a regulated DC, or full-wave rectified, unfiltered power supply.

Speaker

Speaker shall be a System Sensor SpectrAlert Advance Model _____ dual-voltage transformer speaker capable of operating at 25.0 or 70.7 nominal Vrms. Speaker shall be listed to Underwriters Laboratories Standard S4048 for outdoor fire protective signaling systems. Speaker shall have a frequency range of 400 to 4,000 Hz and shall have an operating temperature from –40°F to 150.8°F. Speaker shall have power taps and wattage settings that are selected by rotary switches. The speaker must be installed with its weatherproof back box in order to remain outdoor approved per UL listing S4048. The speaker shall be suitable for use in air handling spaces and wet environments.

Speaker Strobe Combination

The speaker strobe shall be a System Sensor Model _____ listed to UL 1638 and UL 1480 and be approved for fire protective signaling systems. Speaker shall be capable of operating at 25.0 or 70.7 nominal Vrms and shall have a frequency range of 400 to 4,000 Hz. Speaker shall have power taps that are selected by rotary switch. The strobe shall consist of a xenon flash tube with associated lens/reflector system and operate on either 12 or 24 volts. The strobe shall also feature selectable candela output, providing options for 15 or 15/75 candela when operating on 12 volts and 15, 15/75, 30, 75, 110, 115, 135, 150, 177 or 185 candela when operating on 24 volts. The strobe shall comply with the Americans with Disabilities Act requirement for visible signaling appliances, flashing at 1 Hz over the strobe's entire operating voltage range. The speaker strobe must be installed with its weatherproof back box in order to remain outdoor approved per UL. The speaker strobe shall be suitable for use in wet environments.

Physical Specifications

Operating Temperature	–40°F to 151°F (–40°C to 66°C)
------------------------------	--------------------------------

Dimensions, Wall-Mount

SPS Speaker Strobe	6.0" L × 5.0" W × 4.7" D (including lens and speaker)
SP Speaker	6.0" L × 5.0" W × 2.9" D

Dimensions, Wall-Mount Weatherproof Back Box	6.5" L × 5.5" H × 2.9" D
---	--------------------------

Electrical/Operating Specifications

Nominal Voltage (speakers)	25 V or 70.7 V (nominal)
-----------------------------------	--------------------------

Maximum Supervisory Voltage (speakers)	50 VDC
---	--------

Strobe Flash Rate	1 flash per second
--------------------------	--------------------

Nominal Voltage (strobes)	Regulated 12 VDC/FWR or regulated 24 DC/FWR
----------------------------------	---

Operating Voltage Range (includes fire alarm panels with built in sync)	8 to 17.5 V (12 V nominal) or 16 to 33 V (24 V nominal)
--	---

Operating Voltage with MDL3 Sync Module	8.5 to 17.5 V (12 V nominal) or 16.5 to 33 V (24 V nominal)
--	---

Frequency Range	400 to 4,000 Hz
------------------------	-----------------

Power	¼, ½, 1, 2 watts
--------------	------------------

UL Current Draw Data

UL Max. Strobe Current Draw (mA RMS)					
	Candela	8 to 17.5 Volts		16 to 33 Volts	
		DC	FWR	DC	FWR
Standard Candela Range	15	123	128	66	71
	15/75	142	148	77	81
	30	NA	NA	94	96
	75	NA	NA	158	153
	95	NA	NA	181	176
	110	NA	NA	202	195
	115	NA	NA	210	205
High Candela Range	135	NA	NA	228	207
	150	NA	NA	246	220
	177	NA	NA	281	251
	185	NA	NA	286	258

Sound Output				
UL Reverberant (dBA @ 10 ft.)	2W	1W	½ W	¼ W
Outdoor Speaker	90	87	84	81
Outdoor Speaker/Strobe	89	86	83	80

Candela Derating

For K series products used at low temperatures, listed candela ratings must be reduced in accordance with this table.

Strobe Output (cd)	
Listed Candela	Candela rating at -40°F
15	Do not use below 32°F
15/75	
30	
75	44
95	70
110	110
115	115
135	135
150	150
177	177
185	185

Dimensions

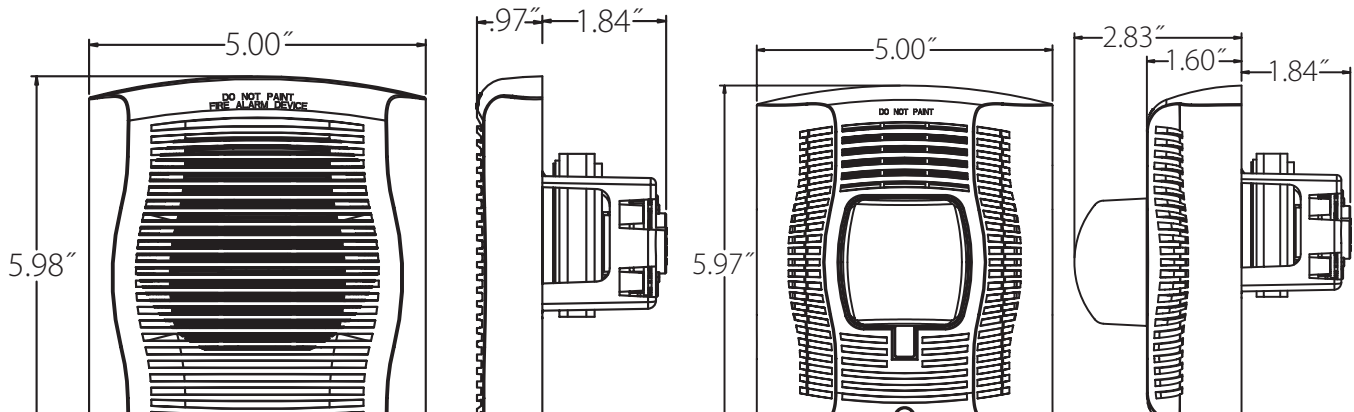

Wall-Mount Outdoor Speaker

Wall-Mount Outdoor Speaker Strobe

Surface Mounting

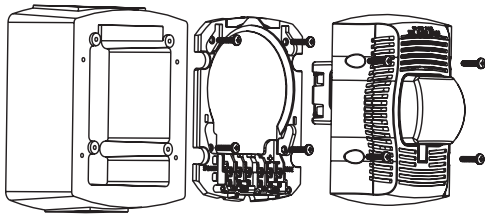

Wall-Mount Speaker Strobe with Plastic Weatherproof Back Box

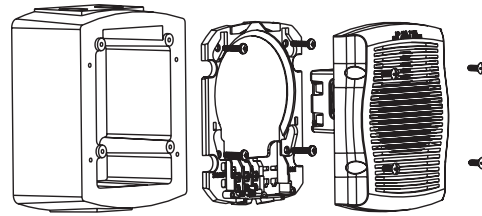

Wall-Mount Speaker with Plastic Weatherproof Back Box

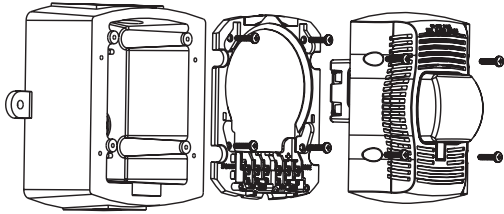

Wall-Mount Speaker Strobe with Metal Weatherproof Back Box

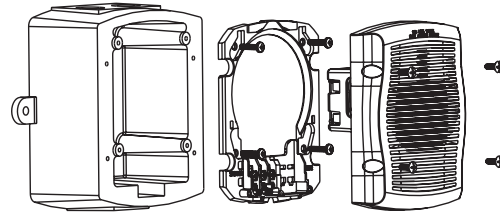

Wall-Mount Speaker with Metal Weatherproof Back Box

Ordering Information for SpectrAlert® Advance Outdoor Speakers and Speaker Strobes

Wall Mount		
White	Red	Description
SPWK	SPRK	Outdoor Speaker (includes plastic weatherproof back box)
SPWK-R	SPRK-R	Outdoor Speaker (does not include plastic weatherproof back box)
SPSWK	SPSRK	Outdoor Speaker Strobe, Standard cd (includes plastic weatherproof back box)
SPSWK-P	SPSRK-P	Plain Outdoor Speaker Strobe, Standard cd (includes plastic weatherproof back box)
SPSWK-R	SPSRK-R	Outdoor Speaker Strobe, Standard cd (does not include weatherproof back box)
SPSWK-CLR-ALERT	—	Outdoor Speaker Strobe, Standard cd, Clear Lens, ALERT Printed (includes plastic weatherproof back box)
—	SPSRHK	Outdoor Speaker Strobe, High cd (135, 150, 177, 185) (includes plastic weatherproof back box)
Accessories		
White	Red	Description
MWBBW	MWBB	Wall, Metal Weatherproof Back Box

Notes:

All -P models have a plain housing (no "FIRE" marking on cover)

"Standard cd" refers to strobes that include 15, 15/75, 30, 75, 95, 110, and 115 candela settings. "High cd" refers to strobes that include 135, 150, 177, and 185 candela settings. **When replacing standard outdoor units, both the device and back box must be replaced.**



3825 Ohio Avenue • St. Charles, IL 60174
Phone: 800-SENSOR2 • Fax: 630-377-6495

©2012 System Sensor.
Product specifications subject to change without notice. Visit systemsensor.com
for current product information, including the latest version of this data sheet.
AVDS11301 • 09/12