

South Hill Business & Technology Center Parking Expansion Project Stormwater Management Report

Prepared for

The Benaroya Co.
3600 136th Place SE, Suite 250
Bellevue, WA 98006



The City will adopt the 2019 Ecology Manual July 1st, 2022. Any projects not vested (Building Permits and Subdivision Applications) and not permitted by the close of business on June 30th, shall incorporate the provisions of the 2019 Ecology Manual. [Storm Report; Pg 1 of 347]

If the current stormwater design complies with the 2019 Ecology Manual, then an acknowledgment letter from the design engineer will suffice for permit issuance. [Storm Report; Pg 1 of 347]

Provide a DRAFT version of the City's Stormwater Facilities Agreement for review. (Note: this is not a condition of permit issuance)[Storm Report; Pg 1 of 347]

Executed and record the City's Stormwater Facilities Agreement prior to permit closeout.[Storm Report; Pg 1 of 347]

Prepared by

Parametrix
1019 39th Avenue SE, Suite 100
Puyallup, WA 98374
T. 253.604.6600 F. 1.855.542.6353
www.parametrix.com

CITATION

Parametrix, 2022. South Hill Business & Technology Center Parking Expansion Project Stormwater Management Report. Prepared by Parametrix, Puyallup, Washington. March 2022.

CERTIFICATION

The technical material and data contained in this document were prepared under the supervision and direction of the undersigned, whose seal, as a professional engineer licensed to practice as such, is affixed below.



Prepared by Zac Garrard, EIT

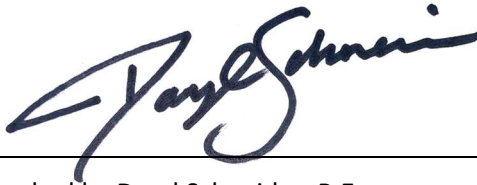

Checked by Daryl Schneider, P.E.

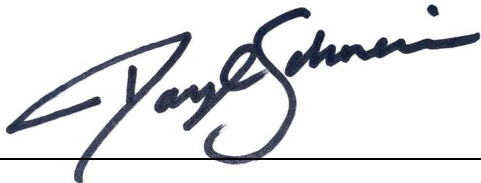

Approved by Daryl Schneider, P.E.



This Page Intentionally Left Blank.

TABLE OF CONTENTS

1. INTRODUCTION	1
2. PROJECT OVERVIEW.....	1
3. EXISTING CONDITIONS	2
3.1 Existing Site Hydrology.....	2
3.1.1 Drainage Basin A (DB - A)	3
3.2 Geotechnical Investigation	4
4. DEVELOPED SITE CONDITIONS.....	4
4.1 Developed Site Hydrology.....	5
4.1.1 Drainage Basin A (DB - A)	5
4.1.2 Drainage Basin B (DB - B)	6
5. OFF-SITE ANALYSIS.....	6
5.1 Resource Review	6
5.2 Downstream Analysis.....	7
6. PERFORMANCE STANDARDS AND GOALS	7
7. BASIC REQUIREMENTS	8
7.1 Requirement #1 Preparation of Stormwater Site Plan	8
7.2 Requirement #2 Construction Stormwater Pollution Prevention Plan (CSWPPP).....	8
7.3 Requirement #3 Source Control of Pollution.....	2
7.4 Requirement #4 Preservation of Natural Drainage Systems and Outfall	2
7.5 Requirement #5 On-Site Stormwater Management.....	4
7.6 Requirement #6 Runoff Treatment.....	4
7.7 Requirement #7 Flow Control.....	5
7.8 Requirement #8 Wetlands Protection	5
7.9 Requirement #9 Operations and Maintenance	6
8. PERMANENT STORMWATER CONTROL PLAN	6
8.1 Methodology.....	6
8.2 Flow Control.....	7
8.3 Runoff Treatment.....	8
8.4 Conveyance System	8

TABLE OF CONTENTS (CONTINUED)

9. OTHER PERMITS.....9

LIST OF TABLES

Table 1 Pre-Development Drainage Basins 4
Table 2 Post-Development Drainage Basins..... 6
Table 3. Operation and Maintenance Plan..... 6
Table 4 Storm Network Analysis..... 9

APPENDICES

30 A. Geotechnical Investigation Report 30
98 B. Grading & Storm Plans 98
115 C. Construction Stormwater Pollution Prevention Plan (CSWPPP) 115
244 D. Western Washington Hydrology Model 2012 Reports 244
337 E. StormShed Conveyance Calculations 337

ACRONYMS AND ABBREVIATIONS

BMPs	best management practices
CFS	cubic feet per second
Ecology	Washington State Department of Ecology
EPSC	erosion prevention and sediment control
hrs	hours
LF	linear feet
LID	low-impact development
NPDES	National Pollutant Discharges Elimination System
NPGIS	Non-Pollution Generating Impervious Surface
NRCS	National Resource Conservation Service
PGIS	pollution generating impervious surfaces
ROW	right-of-way
SF	square feet
SWMMWW	Stormwater Management Manual for Western Washington
SWPPP	Stormwater Pollution Prevention Plan
TMDL	Total Maximum Daily Loads
TSS	total suspended solids
WRIA	Water Resource Inventory Area
WWHM	Western Washington Hydrology Model

1. INTRODUCTION

This report is a stormwater quantity and quality management plan for The Benaroya Company. This report addresses the type of project proposed, the site's existing and developed hydrology, the analysis of off-site drainage as a result of the project completion, the stormwater quantity and quality treatment performance standards, and the stormwater conveyance system analysis and design as required by the Washington State Department of Ecology.

Revise statement to reflect the wetland basin which is tributary to the detention facility. See comments in Section 7.7. [Storm Report; Pg 9 of 347]

2. PROJECT OVERVIEW

The South Hill Business & Technology Center Parking Expansion project proposes to expand their office park parking lot on roughly 10-acres of undeveloped land in Puyallup, WA. The project site is in southeast Puyallup, WA located off SE 39th Avenue east of Bradley Lake and west of Pierce College. The parking expansion will occur on the eastern portion of the existing office park currently in an area that is currently a mixture of gravel maintenance yard area and wooded slopes.

The development includes clearing and grubbing, mass grading earthwork, paving roadway and parking circulation, storm drainage, landscaping, illumination, and pedestrian walkways to serve existing data centers and offices.

The finished site will be approximately 68% impervious with 6.71-acres of paved surfaces and 3.17-acres of pervious landscaping and stormwater management facilities.

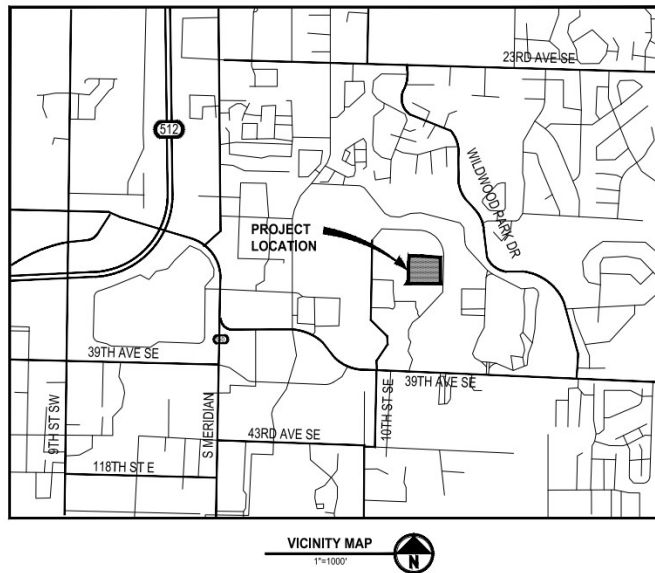

Figure 1 Project Vicinity Map

The Parking Expansion project proposes to construct parking stalls, roughly 6.71-acres of circulation roads, pedestrian walkways, stormwater planters, and site lighting. The site will be mass graded to provide moderate slopes for the parking and roadways, and generally it will follow the existing grades by gradually rising from the existing building along the west to the hillside to the eastern extent of construction limits. The surface parking lot will be split into various drive aisles delineating the rows of

parking stalls with landscape or walkways. Infiltration planters and underground stormwater detention chambers will be used in conjunction with water quality swales to manage all new runoff generated as a result of the project. All runoff generated on-site will be treated to meet water quality standards prior to outfall into infiltration planters or underground detention chambers.

Construction activities of the proposed project will include:

- Clearing and grubbing a wooded hillside
- Demoing a gravel and asphalt maintenance yard
- Grading and mass hauling earth
- Paving parking and accessible stalls, driveways, and circulatory roads
- Pouring sidewalks, curbs, and gutters
- Installing vegetated infiltration galleries, swales, and underground detention chambers

3. EXISTING CONDITIONS

The Parking Expansion project will occur in the east-central portion of the existing business park roughly 9.88-acres in size, which consists of a gravel maintenance yard area adjacent to the eastern building face and extends into an undeveloped wood area in the slopes extending away to the east. The maintenance yard is previously graded and relatively flat with increasing slopes stretching into the wooded area up to match an existing circulation road. The wooded area varies in steepness of slopes, but generally extends to the east with a few areas defined by flatter reliefs and ridges. The wooded area is densely covered in various cedar and fir trees, shrubs, and thickets of blackberry vines. A Class IV wetland is delineated in the south-central portion of the project limits between the existing maintenance yard and rising hillside.

3.1 Existing Site Hydrology

The project site is generally located in southeast Puyallup, WA north of SE 39th Avenue east of Bradley Lake and west of Pierce College. Existing elevations near the project area range from 481' near the edge of the maintenance yard and building face on the west side of the site up to 534' at the top of the wooded hillside on the east side of the site. The existing site is primarily separated into the previously graded maintenance yard and the undeveloped wooded area. The maintenance yard composed of various gravel, asphalt, and concrete hard surfaces gradually slopes away from the eastern building face at slopes $\leq 2.0\%$ with storm drain inlets and structures through the area for runoff generated from these surfaces, which are conveyed through a storm pipe network to the northwest of the site eventually outfalling into Bradley Lake.

The wooded area is densely covered in various types of vegetation. Rainfall over this area does not produce the same concentration of runoff as the developed areas due to abstractions in the hydrologic process as a result of the foliage. Stormwater is managed much closer to the initial source of rainfall by collecting, ponding, and infiltrating into the existing soils. Runoff that does collect sheet flows down the slopes of the wooded area. Most of this runoff is assumed to infiltrate into the subgrade. Other runoff collects at the edge of the maintenance yard.

There is a delineated Class IV wetland, Wetland F, near the south-central end of the project area where groundwater seepage and stormwater runoff seasonally saturate the soils providing conditions for a wetland. A critical areas report has been prepared by others outlining the existing vegetation, hydrologic

functions, and wetland criteria scoring for Wetland F and other wetlands on the property but not within the project vicinity.

Existing drainage patterns encompassing property and construction limits of the site are ultimately one single drainage basin defined amongst two regions-lower developed yard and upper forested hillside as determined by the topographic survey on record. Details of the existing conditions drainage basin can be found in Figure 1.

3.1.1 Drainage Basin A (DB - A)

Drainage Basin A (DB - A) is generally defined by the existing impervious surfaces that drain from east to west and collect along low points between the building's edge and the paved/gravel maintenance yard and extends to top of the hillside that is undeveloped to the central and eastern portion of the project's limits.

The lower region includes the level, gravel maintenance yard between the existing building face and paved maintenance and delivery road. This area slopes gently from the existing building with catch basins and inlets that convey runoff to the northwest into an infiltration pond. Additionally, there is a section of paved maintenance and delivery road extending from the south entrance of the site to a secondary access at the west of the site. The road slopes from the south entrance to the north to the building's external HVAC and generators. Surrounding this access roads are gravel and paved maintenance yards. At the northwestern edge of the basin is a grassy area adjacent to the maintenance yard with a landscaped walking path in the center of the business park. .

The hillside area slopes up gently ($S \leq 5.0\%$) from the maintenance road to a flatter slopes area that is delineated as a Wetland F. The topography steepens to the east with a maximum slope nearing 33% before flattening at the top of the hillside. The central portion of DB - A includes the vegetated area bordering the edge of the paved maintenance yard and extending east to the site's high point at roughly an elevation of 534'. A few ridges extend out in the hillside defining the basin.

Runoff originating from the paved, gravel, and other impervious surfaces travels to the edges or low points in the basin and is collected in trench drains and catch basins. The heavy forest and vegetative cover in the hillside limit the amount of runoff generated from the area and most runoff is assumed to be infiltrated into the existing subgrade. Any runoff surface flows convey into and through Wetland F and other flatter areas of vegetation where it is assumed to infiltrate or evaporate. Approximately, 1.21-acres of the forest hillside contributes towards Wetland F. The combination of surface runoff and groundwater seepage saturate depressions in the wetland area seasonally. Ponding may occur during prolonged periods of saturation, but the wetland does not contain a permanent pool of water.

The existing storm system conveys outside the project limits to an existing infiltration pond constructed within the property of the existing business park. This infiltration pond is assumed to be built for the entire property's development. It is approximately a 9-foot-deep infiltration pond with an estimated storage volume of 6,500 cubic yards based on areas measured from a previously prepared ALTA. The existing pond is fenced for safety, so topographic survey of its volume and infiltration testing were not performed due to accessibility. Furthermore, it is assumed that the overflow structure in the infiltration pond is designed to discharge overflow events into Bradley Lake at flowrates less than or equal to pre-development conditions of the previous development.

Table 1 Pre-Development Drainage Basins

Basin	Basin Characteristics	Basin Area
DB – A	Level gravel area adjacent to the office building. Paved driveway, maintenance yard, and loading dock area. Trench drains and catch basins are intermittently placed at low points. Wooded hillside in the center of the site extending to the north, south, and east limits of the project area.	9.88-acres
Total:		9.88-acres

See Figure 1 showing the pre-development drainage basin for additional details.

3.2 Geotechnical Investigation

A geotechnical investigation identified that the site sits on fill overlying complex layering of recessional outwash/ice contact deposits. The near-surface deposits generally consist of medium dense silty sand with variable gravel content. In some of the test pits cobbles were encountered and in others clean sand and gravel were present.

Groundwater seepage was encountered in some test pits ranging in depths from 6’ to 8.5’ below ground surface. Groundwater levels should be expected to fluctuate seasonally and following significant rain events.

Preliminary infiltration testing occurred at six locations throughout the site. Along the lower portions of the site (PIT 1-20, 2-20, 3-20, 4-20) near the maintenance yards, testing indicated poor to zero infiltration in addition some groundwater seepage. In the wooded hillside (PIT 5-20 and PIT 6-20), infiltration tests yielded feasible infiltration rates for stormwater facilities with long-term infiltration rates ranging from 2.9 -5.7 inches per hour).

Further details are outlined in Appendix A.

4. DEVELOPED SITE CONDITIONS

The Parking Expansion project proposes to construct 6.71-acres of impervious surfaces including parking stalls, circulation roads, pedestrian walkways, stormwater planters, and site lighting. The site will be mass graded to provide moderate slopes for the parking and roadways, and generally it will follow the existing grades by gradually rising to the east to the extent of construction limits. The surface parking lot will be split into various drive aisles delineating the stalls with landscape or walkways breaking up the rows of parking. Infiltration planters and underground stormwater detention chambers will be used in conjunction with bioretention and grassy swales to manage all new runoff generated as a result of the project. All runoff generated on-site will be treated to meet water quality standards prior to outfalling into infiltration planters or underground detention chambers. Runoff will be released from the detention chambers at flowrates equal to or less than pre-development forested conditions to the existing storm system that outfalls into an existing infiltration pond. A portion of the site, approximately 1-acre, will remain undeveloped to preserve the drainage basin and hydrologic conditions sustaining Wetland F.

For additional detail, please see the post developed basin map in Figure 2 as well as the civil plans.

4.1 Developed Site Hydrology

The paved roadways and other hardscapes impervious surfaces will result in a greater quantity and concentration of stormwater runoff. The site will be graded to convey runoff into infiltration planters, swales, and bioretention areas to treat and filter pollutants from the stormwater runoff. Infiltration planters will be constructed in the upper parking area at locations explored by a geotechnical investigation that identified soils with infiltration rates suited for it. The swales aligning the center of the drive aisles in the lower parking area will collect sediment, filter pollutants, and convey treated runoff through underdrains into an underground chamber detention system. Runoff will be released from the detention chambers at flowrates equal to or less than pre-development forested conditions via a control structure at the outlet prior to the existing storm system that discharges into the existing infiltration pond in the northwest corner of the business park property.

By discharging runoff at pre-development forested flowrates into this infiltration pond, the facility is assumed to have adequate capacity for this additional runoff. It is approximately a 9-foot-deep infiltration pond with an estimated storage volume of 6,500 cubic yards based on areas measured from a previously prepared ALTA survey. See Figure 3 for reference. Furthermore, there is an overflow structure in the infiltration pond that discharges overflow events into Bradley Lake.

The contributing drainage area to Wetland F will be remain undeveloped and pervious as much as possible to maintain the existing drainage and hydrologic characteristics of Wetland F. Approximately 1.05-acres of the site will be restricted from construction activities to maintain the forested, hillside upland of Wetland F.

4.1.1 Drainage Basin A (DB - A)

Drainage Basin A composes the entry roads and lower parking area, which slopes up from the face of building at roughly 6%-10% to the elevation of 500' as well as the drive aisles extending into the upper parking area. The undeveloped area contributing to Wetland F and downslope of its depressed area are also included in DB – A as runoff may flow through the wetland and down into a grassy swale aligning the entry road.

Within DB - A, columns of parking aisles shed into bioretention swales in the centers between the rows of parking. Overflow inlets and perforated drainpipes are to be installed at the low points within the swales to collect treated stormwater and convey it into a large underground storm chamber system. The treated runoff will be detained within the storm chambers. Runoff will be released from the detention chambers at flowrates equal to or less than pre-developed forested conditions via a control structure at the outlet prior to discharging into the site's existing storm system. The existing storm system will then convey runoff to an existing infiltration pond.

The existing access road from the south of the property will be improved and include a grassy swale adjacent to the road to collect, convey, and treat runoff. A catch basin overflow will be installed at the low point that connects to the chamber system.

The contributing drainage area to Wetland F will be remain undeveloped and pervious as much as possible to maintain the existing drainage and hydrologic characteristics to maintain Wetland F. 1.05-acres- of the site will be limited to construction activities to maintain the forested, hillside upland of Wetland F. Runoff through the trees and vegetation will either infiltrate into the subgrade or flow into and through Wetland F down the hillside. Runoff flowing past Wetland F will be collected and conveyed in the grassy swale aligning the improved access road.

Due to the grades associated with the project, provide a letter from a licensed geotechnical engineer assessing the potential for lateral flow of the infiltrated runoff and whether any lateral flow will impact the proposed conventional paving and/or existing structures. If there are concerns due to lateral flow of the infiltrated runoff, redesign accordingly. [Storm Report; Pg 14 of 347]

4.1.2 Drainage Basin B (DB - B)

Drainage Basin B is defined by the three tiers of upper parking that will be built into the hillside. The parking aisles will be sloped at 6% to minimize the vertical difference between tiers limiting the need for retaining walls. In the upper portion of the hillside at the edge of proposed construction activities will remain portions of the existing forested hillside. This area will be entirely pervious surfaces from existing stands of trees and proposed landscaping along the catch slopes of the site. The tiers of parking will slope gently down to the north, and a gutter pan along the lower parking stalls will convey runoff to curb cuts that drain into an infiltration planter. The infiltration planters will be installed at locations where infiltration testing indicated high design infiltration rates (2.9 -5.7 inches per hour) in the existing soils. Two planters will be installed in each tier to manage all runoff generated. A water quality soils mix will treat and filter runoff prior to infiltrating into the subgrade. The infiltration planters are sized to infiltrate runoff from their respective contributing areas up to the 50-year event

Table 2 Post-Development Drainage Basins

Basin	Basin Characteristics & Outfall	Basin Area ¹
A	Lower parking area with landscaping, sidewalks, and swales. Runoff will be detained in underground detention chambers.	6.83-acres
B	Upper parking area with landscaping, sidewalks, existing hillside, and infiltration planters. Runoff will infiltrate in infiltration planters.	3.05-acres
Total:		9.88-acres

Details of the post-development drainage basins can be found in Figure 2.

5. OFF-SITE ANALYSIS

The off-site analysis involves a resource review and downstream analysis. The resource review includes research and analysis of reports, maps, and recent studies to identify drainage basins, receiving waters, sensitive areas, and other information pertinent to the project site. Downstream analysis involves the investigation of impacts downstream of the site and the possible need to mitigate such impacts.

5.1 Resource Review

The project is located within the Puyallup-White Watershed (WRIA) with the nearest major drainage catchment being the Puyallup River. It's within the State Highway drainage basin defined by the City of Puyallup drainage basin overview. The project site's existing stormwater is primarily retained on-site on vegetation or from evapotranspiration in the forested hillside, and runoff from the developed maintenance yards collects and discharges off-site after collecting in catch basins at low points. An existing storm drain system conveys runoff to the northwest where it ultimately discharges into an existing infiltration pond adjacent to Bradley Lake. A flow control structure conveys overflow events into Bradley Lake.

The proposed construction activities are outside of a floodplain.

5.2 Downstream Analysis

An analysis was conducted to determine if project construction will create any drainage problems downstream of the project limits.

Portions of the undeveloped wooded hillside of the site (approximately 2.27-acres total) will remain undisturbed as a result of the project. Densely vegetated areas will help retain and slow stormwater flow through these basins, while minimizing the total volume of runoff generated from these areas.

Furthermore, the contributing drainage area to Wetland F will be remain undeveloped and pervious as much as possible to maintain the existing drainage and hydrologic characteristics to maintain Wetland F. A wetlands fluctuation analysis indicates that the limited construction activities in the area will maintain sufficient flowrates to sustain the wetland conditions for Wetland F. See Section 7.8 for further information.

The increased volume and flowrates of stormwater runoff from new impervious surfaces will be managed on-site via underground detention chambers, bioretention swales, and infiltration planters that will treat, infiltrate, and discharge runoff at pre-development forested conditions flow rates into an existing infiltration pond.

The combination of maintaining undeveloped forested areas, protecting wetlands, detaining runoff in storm chambers and infiltration facilities, and discharging stormwater off-site a pre-development forested flowrates will limit impacts on downstream water bodies.

6. PERFORMANCE STANDARDS AND GOALS

Per the SWMMWW, construction activities within Western Washington that disturb 5,000 SF or more of land are required to control erosion and install structures to manage stormwater quality and quantity. The completion of the project will meet or exceed the following requirements to ensure protection of downstream natural resources:

Erosion Control – A Construction Stormwater Pollution Prevention (CSWPP) Plan is required on all land-disturbing activities. The project is subject to erosion and sediment prevention inspection procedures, and approved BMPs must be installed before any construction activity can begin.

Stormwater Quality Treatment – The pollutant reduction requirement for stormwater treatment to treat at least 91-percent of the average annual runoff volume generated by PGIS. Proposed stormwater facilities must be capable of reducing total suspended solids (TSS) by 80 percent, as well as treating pollutants of concern from Washington Department of Ecology-identified total maximum daily loads (TMDLs) of waterbodies surrounding the project site.

Stormwater Flow Control – The goal of flow control is to mitigate to the maximum extent practicable the impacts of increased stormwater runoff volumes and flow rates on streams in western Washington. Practices that infiltrate runoff and/or are vegetated shall be used to the maximum extent practicable. Infiltrating stormwater should occur as close to the impervious surface generating the runoff as feasible. Stormwater management facilities must be sized to retain and/or infiltrate up to the design storm event, and if the stormwater facility is unable to manage the design storm, flow controls must be installed to ensure runoff can be conveyed to an approved off-site discharge at a peak flow rate equivalent to pre-development forested conditions.

Conveyance System Capacity – A conveyance system must be designed to route any stormwater into and away from any stormwater facility. Overflow scenarios shall be considered. The conveyance system must be designed to have sufficient capacity to convey the runoff to an approved discharge point at flow rates equivalent to pre-development forested conditions.

Source Control – To ensure that pollutants generated on-site do not enter the stormwater system and to protect local waterways, source control measures must be in place for certain uses, activities, and materials that require additional stormwater considerations.

7. BASIC REQUIREMENTS

The South Hill Business & Technology Center Parking Expansion Project meets the definition of new development and proposes to add over 5,000 SF impervious surface and land disturbing activity. Per Figure I-2.4.1 from the SWMMWW below in Figure 2, the entire project site is subject to Core Elements 1-9 applicable for all new PGIS and NPGIS constructed upon project completion.

7.1 Requirement #1 Preparation of Stormwater Site Plan

Preparation of this stormwater management plan in accordance with the SWMMWW outlines and satisfies this criterion. The proposed development activities are indicated in the South Hill Business & Technology Center Parking Expansion Project Stormwater Management Report civil design plan set submitted separately. Stormwater elements are outlined within this report in conjunction with the plan set.

7.2 Requirement #2 Construction Stormwater Pollution Prevention Plan (CSWPPP)

These thirteen erosion control requirements below must be evaluated for the project applicability and implemented prior to and during any ground-clearing and construction activities:

1. Mark Clearing Limits
2. Establish Construction Access
3. Control Flow Rates
4. Install Sediment Controls
5. Stabilize Soils
6. Protect Slopes
7. Protect Drain Inlets
8. Stabilize Channels and Outlets
9. Control Pollutants
10. Control Dewatering
11. Maintain BMPs
12. Manage the Project
13. Protect Low Impact Development BMPs (Infiltration BMPs)

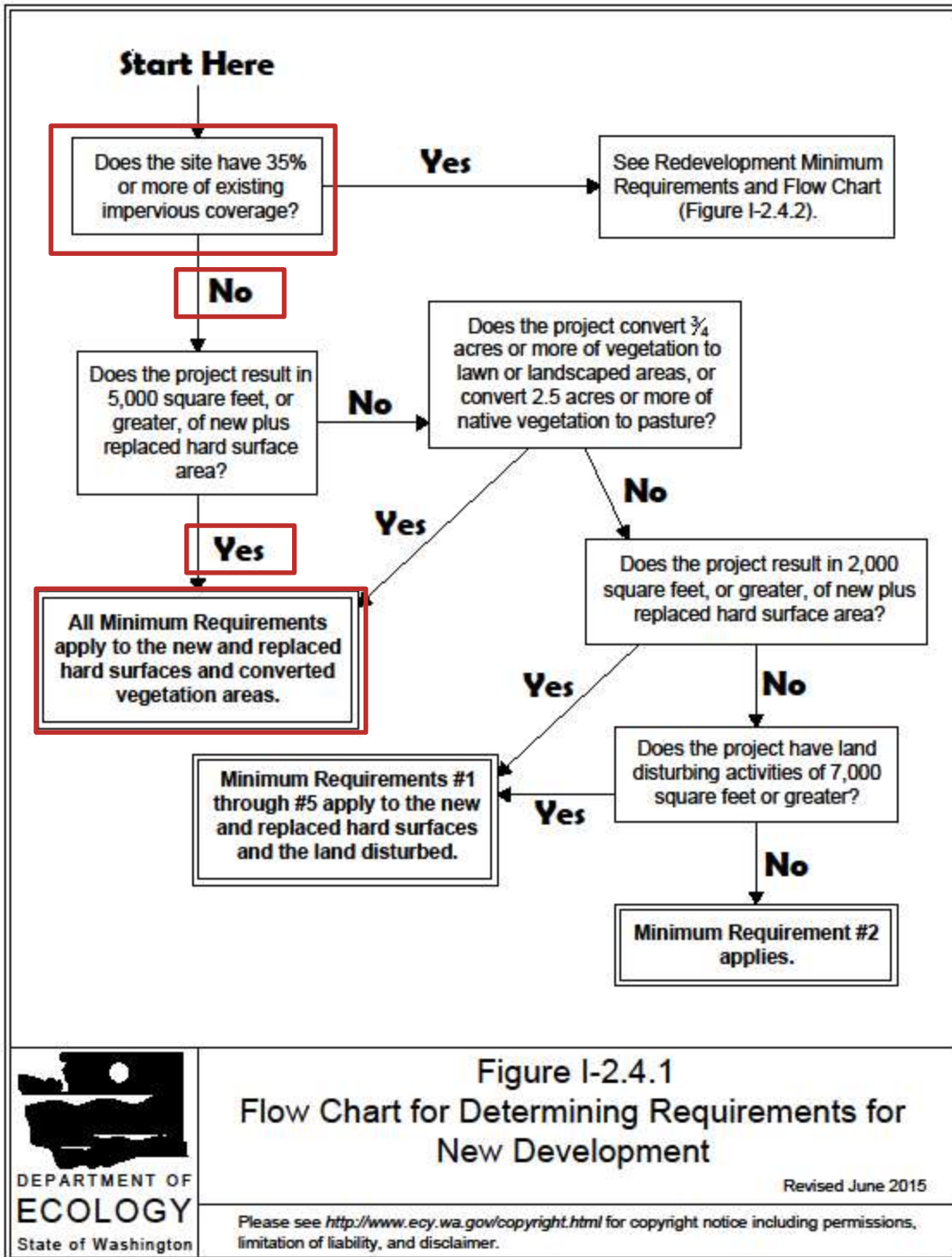

Figure I-2.4.1
Flow Chart for Determining Requirements for New Development



Revised June 2015

Please see <http://www.ecy.wa.gov/copyright.html> for copyright notice including permissions, limitation of liability, and disclaimer.

Figure 2 Flow Chart for Determining Requirements for New Development

A Construction Stormwater Pollution Prevention Plan (CSWPPP) is attached as Appendix C. Appropriate BMPs will be included in the CSWPPP with necessary details to meet the thirteen CSWPPP elements. It is the contractor's responsibility to follow the CSWPPP, utilize the BMPs indicated throughout the duration of the project's completion, and maintain an updated CSWPPP on-site for reference as amendments are incorporated.

7.3 Requirement #3 Source Control of Pollution

The source-control BMPs listed below give a broad overview of measures that will be taken to prevent stormwater from coming into contact with pollutants on-site, both during and after construction activities:

To minimize dust generation during construction, soil will be wetted down with water prior to ground disturbance. All generated waste must be properly disposed of.

Loose aggregate chunks and dust will be swept or shoveled and collected (not hosed down a storm drain) for recycling or proper disposal.

A Spill Prevention Countermeasures and Control (SPCC) Plan is required from the contractor to mitigate any potential spills or leaks from construction materials, machinery, and equipment during construction.

7.4 Requirement #4 Preservation of Natural Drainage Systems and Outfall

Natural drainage patterns and discharges from the project site at the natural location will be maintained to the maximum extent practicable. As previously discussed in Developed Site Hydrology, the finished site grading will slope parking to the east up the hillside and terrace tiers of parking into the existing hillside. The hillside will be graded to more moderate slopes for the drive and parking surfaces, but the hill's general slope from west to east will be maintained.

The contributing drainage area to Wetland F will remain undeveloped and pervious as much as possible to maintain the existing drainage and hydrologic characteristics to maintain Wetland F. 1.05-acres of the contributing area will be limited to construction activities to maintain the forested, hillside upland of Wetland F. Runoff through the trees and vegetation will either infiltrate into the subgrade or flow into and through Wetland F down the hillside. A wetland fluctuation analysis was prepared in WWHM2012 to confirm compliance. Further discussion is outlined below in Section 7.8.

Runoff generated from the new impervious surfaces in the upper parking area will infiltrate on-site via infiltration planters, and runoff on the lower parking area will be detained prior to discharging to an existing infiltration pond outside the project limits. In doing so, natural, and existing drainage systems will be maintained as feasible in coordination with the site development.

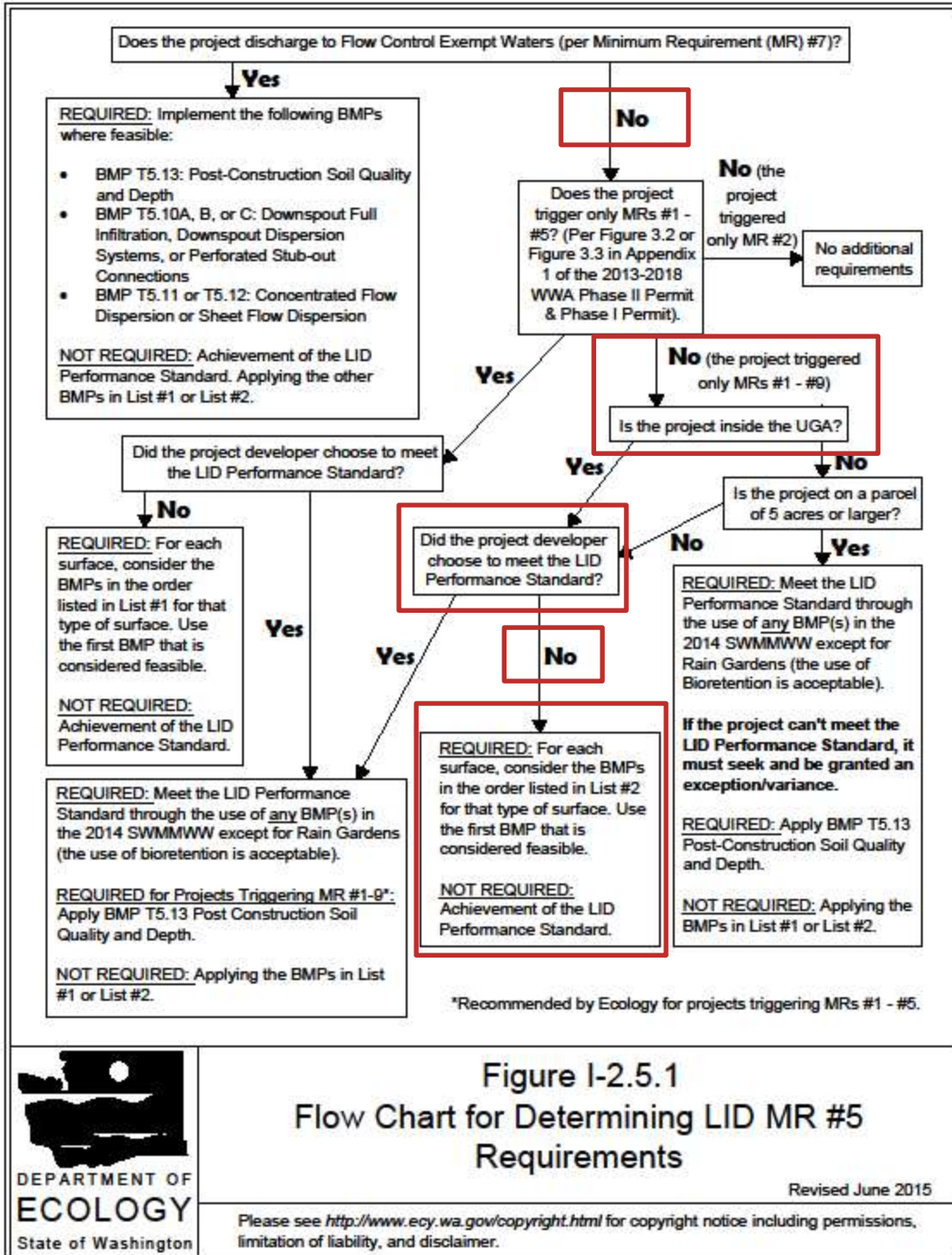

Figure I-2.5.1
Flow Chart for Determining LID MR #5 Requirements



Revised June 2015

Please see <http://www.ecy.wa.gov/copyright.html> for copyright notice including permissions, limitation of liability, and disclaimer.

Figure 3 Flow Chart for Determining LID MR#5 Requirements

7.5 Requirement #5 On-Site Stormwater Management

The South Hill Business & Technology Center Parking Expansion Project shall employ BMPs to infiltrate and detain stormwater runoff on-site to the extent feasible without causing flooding or erosion impacts.

As previously mentioned in Developed Site Hydrology, the site will be graded to convey runoff into infiltration planters, swales, and bioretention areas to treat and filter pollutants from the stormwater runoff. Infiltration planters will be constructed in the upper parking area at locations explored by a geotechnical investigation that identified soils with suitable infiltration rates. The swales aligning the center of the drive aisles in the lower parking area will collect sediment, filter pollutants, and convey treated runoff through underdrains into an underground chamber detention system.

DB - A will shed runoff into bioretention swales to treat stormwater prior to conveying into underground detention chambers where it will be detained. Modelling indicates that DB - A will not meet LID performance standards, and as a result an MR 5 List 2 Analysis is required. See Figure 3 Flow Chart for Determining LID MR#5 Requirements above for the determination. The following BMPs will be employed for the respective surface type:

- Lawn and landscaped area:
 - Post construction soil qualities and depths will be met by retaining the existing duff layer for reuse or soils will be improved to support the establishment of vegetation and proposed plantings.
- Hard surfaces and impervious areas:
 - The centers between columns of drive aisles will be aligned with bioretention swales with a bioretention cell at the low point for water quality treatment prior to flowing into the underground chamber system.

DB - B will grade the tiered parking aisles towards infiltration planters that will filter runoff through water quality soils mix prior to infiltrating into the subgrade. DB - B will infiltrate all run-off and as a result meet LID performance standards.

Enhanced Treatment required (commercial site tributary to freshwater supporting aquatic life).
[Storm Report; Pg 20 of 347]

7.6 Requirement #6 Runoff Treatment

To reduce pollutant loads and concentrations in stormwater runoff BMPs must be implemented to protect water quality so that beneficial uses of receiving waters are maintained. Basic treatment treats at least 91% of the annual runoff generated by PGIS on-site and removes sediment, oils, and metals where applicable to the site. Sediment laden runoff is the primary concern of pollutants on-site.

DB - A will utilize bioretention swales with underdrains to filter runoff through 18" of amended soils prior to conveying into the underground storm chamber system. The amended soil media will collect sediment and pollutants as the stormwater filters through the soils into the underdrains, thus meeting this requirement.

DB - B will utilize the 18" of amended soils prior to infiltrating runoff into the sub grade. By infiltrating 100% of the run-off from this basin, the runoff treatment is met.

See Appendix D for WWHM results indicating treatment credit results.

In the pre-developed condition, there is one threshold discharge area (TDA) and subsequently one Point-of-Compliance (POC). As a result, the post-developed scenario must be addressed holistically as one POC. That is, either the entire proposed area of disturbance complies with the LID Performance Standard or List 2 applies to the whole. It is not appropriate to breakdown a given TDA into smaller portions in an effort to meet MR5 requirements. Since the LID Performance Standard cannot be met for the TDA, List 2 must be evaluated for DB-B, in addition to DB-A, and Permeable Pavement feasibility addressed since it is a higher BMP than the proposed Bioretention BMP under the Other Hard Surfaces category. (See Ecology, Vol. V, Pg 5-20 for infeasibility criteria for permeable pavement related to slope). [Storm Report; Pg 20 of 347]

In the Mitigated scenario, the Wetland Basin is tributary to the storm collection system. Per Ecology, if the Wetland Basin 100yr peak flow is greater than 50% of the project's post-development undetained flow (WWHM 701), then the runoff MUST bypass the storm facility. If less than 50% and the runoff is not bypassed, then the storm facility must be sized to account for the additional offsite inflow/runon. [Storm Report; Pg 21 of 347]

7.7 Requirement #7 Flow Control

See Section 7.5 regarding the reasonability of using Permeable Pavement before Bioretention. [Storm Report; Pg 21 of 347]

Mitigation of increased runoff volumes and flowrates is required to reduce the impacts of development to protect waterbodies' morphology.

In DB – A runoff will be conveyed into an underground chamber system following treatment in a bioretention swale where it will be released through a riser flow control structure to an existing off-site basin. Runoff flows through the bottom of the swale, which slows the flowrate of runoff and deposits larger sediment and pollutants. As it nears the end of the swale, it collects and filters through the amended soils mix into a trench of gravel drainage rock with a perforated underdrain pipe conveying treated runoff into the underground detention chambers. The process of collecting, filtering, and conveying runoff through the swale further reduces flowrates. Lastly, the underground detention chamber system is sized to detain the runoff volumes prior to discharging at forested pre-development flowrate conditions through a riser flow control structure, thus meeting flow control requirements for contributing areas.

See Section 4.1.2 comment regarding lateral flow. [Storm Report; Pg 21 of 347]

In DB - B, the upper parking area will be managed by a series of infiltration planters. A geotechnical investigation indicated existing soils were suited to infiltrate runoff following infiltration testing. The planters are sized to infiltrate all contributing runoff up to the 50-year event. The process of filtering through amended soils and infiltrating runoff into the subgrade meets flow control requirements.

See Appendix D for WWHM results indicating passing duration flows.

7.8 Requirement #8 Wetlands Protection

To ensure that wetlands receive the protection from pollutants, measures shall be taken to ensure safety of the wetland areas. Wetlands are extremely important natural resources that provide multiple functions and values, including ground water recharge, flood control, and stream channel erosion protection. They are easily impacted by development unless careful planning and management are conducted. Wetlands can be severely degraded by stormwater discharges from urban development due to pollutants in the runoff and also due to disruption of the natural hydrologic pattern of the wetland.

The wetland delineated in existing conditions DB - A, Wetland F, is classified as a Class IV Slope wetland with no permanent surface waters but periods of saturation from upland sheet flow and groundwater seeps (see attached condensed wetland report). As a result, the existing drainage basin flows through the wetland and outfalls elsewhere.

The contributing drainage area to Wetland F will ~~be~~ remain undeveloped and pervious as much as possible to maintain the existing drainage and hydrologic characteristics to maintain Wetland F. 1.05-acres of the contributing area will be limited from construction activities to maintain the forested, hillside upland of Wetland F. Runoff through the trees and vegetation will either infiltrate into the subgrade or flow into and through Wetland F down the hillside.

A wetlands fluctuation analysis was prepared and indicates that the proposed construction activities near Wetland F will meet MR 8 requirements.

See the attached WWHM analysis in Appendix D for further details.

7.9 Requirement #9 Operations and Maintenance

All of the proposed stormwater facilities for the project are located on private property and will be the property owner’s responsibility for their operation and maintenance. An Operations & Maintenance (O&M) Manual will be prepared and submitted separately. Common maintenance tasks for the stormwater facilities are listed in Table 3.

Table 3. Operation and Maintenance Plan

Facility	Frequency	Maintenance
Conveyance Systems	Annually and major storm event	<ul style="list-style-type: none"> Use rodding to clear any root invasion. Replace damaged pipes with dents or punctures that impact performances. Remove vegetation that reduces free movement of water through pipes. Flush pipe networks from cleanouts to clear debris.
Catch Basin	Biannually and major storm event	<ul style="list-style-type: none"> Dry sweep the parking lots and access drives at least every 6 months to reduce accumulation of sediments and debris. Clean and dispose of trapped sediments from sump at least every 6 months and after major storms. Dispose of any debris or accumulated sediment properly, according to federal, state, and local jurisdictions.
Energy Dissipators	Annually	<ul style="list-style-type: none"> Replace rock pad or riprap when native soil is visible. Replace rock pad/riprap and backfill if soil erosion exceeds 6 inches.
Water Quality Swale	Biannually	<ul style="list-style-type: none"> Vegetation must cover at least 90% of the facility at maturity. Maintain grass height at 6”-9”. Trim to allow sight lines and foot traffic, also to ensure inlets and outlets freely convey stormwater into/out of the facility. Remove sediment accumulation more than 4-inches deep. Replace mulch annually to a depth 2-3 - inches
Underground Storm Chambers	Biannually and major storm event	<ul style="list-style-type: none"> Remove sediment accumulation more than 4-inches deep within sediment traps. Flush pipe networks from cleanouts to clear debris.

8. PERMANENT STORMWATER CONTROL PLAN

A permanent storm control plan is required because the project proposes over 5,000 SF of land-disturbing activity. Water quality treatment removes pollutants generated from impervious surfaces to prevent downstream pollution from runoff discharging off-site. Flow control facilities are necessary to mitigate potential adverse impacts on downstream properties and waterbodies due to the increase in stormwater runoff caused by increased impervious surfaces.

Details of the stormwater facilities can be found in Appendix B.

8.1 Methodology

The SWMMWW was used as a reference to complete hydrologic analysis and design to select appropriate BMPs for runoff treatment and flow control from the site’s new runoff. Hydrologic analysis of pre- and post-development conditions are based on hydrographs, water quality flowrates, and discharge flowrate comparisons were determined using Western Washington Hydrology Model 2012 (WWHM 2012).

Pre-development forested surface conditions were analyzed by using long-term recorded precipitation data for regional specificity, historic vegetation and land conditions, and continuous simulation hydrology modeling. The contributing impervious areas were compared at equivalent existing forested conditions land use characteristics for vegetation coverage and topographic characteristics.

Pre-development basins were modelled as a combination hydrologic soils type C, forested land, over moderate slopes to steep slopes for the wooded hillside with a small portion accounting for Wetland F as flat, saturated forest. WWHM models times of concentrations (Tc) and rainfall events from historical data.

Please label as subbasins. [Storm Report; Pg 23 of 347]

Post-development surface conditions were analyzed comparing the same precipitation data and continuous simulation hydrology modelling with the new land use basin characteristics following construction completion. Contributing areas were modeled as flat and moderate sloped roads; moderate and steep sloped, type C lawn and forest; and a small portion accounting for saturated forest were used within the two drainage basins.

6.83 per Basin Exhibit, but need to include wetland basin too. [Storm Report; Pg 23 of 347]

DB - A is modelled as the lower parking area as single basin area (6.55-acres) of road surface conveying into the summation surface area of all proposed water quality swales. The swales are modelled for water quality requirements and account for underdrains. The bioretention nodes accounts for precipitation over the facility and is not included in the total basin area a result. Runoff then conveys into the underground storm chamber, which is sized to detain and discharge contributing runoff at forested condition flowrates. A riser flow control structure restricts flowrates prior to through the outlet pipe.

3.05 per Basin Exhibit. [Storm Report; Pg 23 of 347]

DB - B is modelled as the upper parking area as single basin area (2.92-acres) of impervious road surfaces and pervious areas with runoff conveying into the summation surface area of all proposed infiltration planters. The bioretention nodes accounts for precipitation over the facility and is not included in the total basin area a result. An infiltration rate of 2.9-inches per hour is utilized as recommended from geotechnical investigation and infiltration testing.

Stormwater modelling can be found in Appendix D.

8.2 Flow Control

and replaced [Storm Report; Pg 23 of 347]

The purpose of flow control is to mitigate to the maximum extent practicable the impacts of increased stormwater runoff volumes and flow rates on waterbodies as a result of new development. Flow control is applicable to all new PGIS and NPGIS surfaces constructed as a result of the project.

As previously mentioned in the Developed Site Hydrology section, runoff will be infiltrated in the upper parking area in DB - B and detained in underground detention chambers in DB - A. The respective stormwater management facilities were modelled in WWHM and designed to manage contributing stormwater runoff as a result of developed conditions on-site up to the 50-year event as described above.

In DB - A runoff in the lower parking area will shed into bioretention swales and cells prior to discharging into an underground NDS Storm Chamber system. The bioretention swales supplement flow control requirements by extending the time in which runoff discharges from impervious surfaces to the chamber system. As runoff nears the low point of the swale, it collects and filters through the amended soils mix into a trench of gravel drainage rock with a perforated underdrain pipe conveying treated runoff into the underground detention chambers. The chamber system is roughly 447'x 31' (L x W) with 65" of storage depth with approximately 45,000 cubic feet of total volume storage. Additionally, the

underground detention chamber system is sized to detain and discharge runoff up to the 50-year event's runoff volumes. An outlet is provided to discharge runoff at flowrates less than or equal to forested conditions into from significant events into the business park's existing storm system, which outfalls into an infiltration pond adjacent to Bradley Lake.

Runoff from Basin B in the upper parking will flow into one of six infiltration planters that will be 94' x 10' x 3.50' (L x W x D) backfilled with drainage rock and 18" of water quality soils mix including one foot of freeboard. The planters are sized to detain, filter, and infiltrate all contributing runoff.

Stormwater modelling can be found in Appendix D.

8.3 Runoff Treatment

The purpose of runoff treatment is to reduce pollutant loads and concentrations in stormwater runoff using physical, biological, and chemical removal mechanisms to protect water quality so that beneficial uses of receiving waters are maintained. Runoff generated by PGIS are subject to runoff treatment BMPs.

The bioretention and grassy swales as well as the infiltration planters will utilize a combination of amended soils, vegetation, and/or sloped channel bottom to meet water quality requirements. Bioretention combines the processes of filtration, infiltration, adsorption, sedimentation, and absorption of stormwater pollutants that occur as runoff collects in the swale. Runoff that flows into the perforated underdrain or overflow structure will have deposited much of its sediment and debris, and oils and pollutants should leech into the amended soils. This runoff will be treated prior to discharging into the detention chambers.

See Appendix D for WWHM results indicating treatment credit results.

8.4 Conveyance System

The proposed stormwater conveyance system is limited to catch basin outfalls and runs of overflow storm pipe conveying treated runoff to respective stormwater facilities. Surge at structure's is not expected due to the small basin size contributing to the catch basins and pre-treatment in swales or infiltration planters. Pipe sizes and slopes are designed for capacity to convey runoff up to the 25-year peak flowrate and to meet City of Puyallup design standards.

Conveyance calculations were prepared in StormShed to confirm capacity within the proposed conveyance system connection for runoff up to the 25-year event. Table 4 Storm Network Analysis provides the capacity check for the proposed storm conveyance system. The proposed conveyance system will be installed with sufficient capacity to conveyance runoff from the proposed project.

Table 4 Storm Network Analysis

Pipe ID	Area (ac)	Design Q(cfs)	Full Q (cfs)	Flow ratio	Design D(ft)	Depth ratio	Size	Design V(fps)	Full V(fps)
Bio-Swale	0.90	0.7064	----	0.00	0.1821	----	Ditch	1.0936	-----
Underdrain	0.90	0.7064	1.4564	0.485	0.2456	0.4913	6 in	7.3588	7.4176
Pipe 003	0.90	0.7064	3.6488	0.1936	0.2983	0.2983	12 in	3.5926	4.6457
Entry Swale	1.30	0.5483	----	0.00	0.3779	----	Ditch	0.463	-----
Pipe 001	1.30	0.5483	2.7091	0.2024	0.3052	0.3052	12 in	2.7016	3.4493
Pipe 002	1.30	0.5483	5.5368	0.099	0.2124	0.2124	12 in	4.4998	7.0497
Pipe 004	2.20	1.2521	3.6488	0.3431	0.4039	0.4039	12 in	4.2128	4.6457

Further details of the conveyance network can be found in Appendix E.

9. OTHER PERMITS

Permits required or anticipated for this project are listed below.

- National Pollutant Discharge Elimination System (NPDES) General Construction Permit

Figures

PATH: U:\PSO\Projects\Clients\7312-Benaroya\217-7312-004_SHB&TParkingExpansion\02MBS_Stormwater
 PLOTTED BY: GarraWJ DATE: Monday, February 7, 2022 6:01:43 PM
 LAYOUT: Pre

GENERAL NOTES:

1. RUNOFF WILL BE CONVEYED INTO THE BRADLEY LAKE IF CONVEYED OFF-SITE FROM EXISTING INFILTRATION POND.
2. EXISTING CATCH BASINS LOCATED AT LOW POINTS OF THE MAINTENANCE YARD CONVEY RUNOFF TO AN EXISTING INFILTRATION POND NORTHWEST OF THE PROJECT AREA.
3. RUNOFF CONTRIBUTING TO WETLAND F IS WITHIN DRAINAGE BASIN A. PORTIONS OF RUNOFF WILL POND IN WETLAND F WHILE SOME WILL FLOW THROUGH OR OVERFLOW TO LOW POINTS IN DRAINAGE BASIN A.

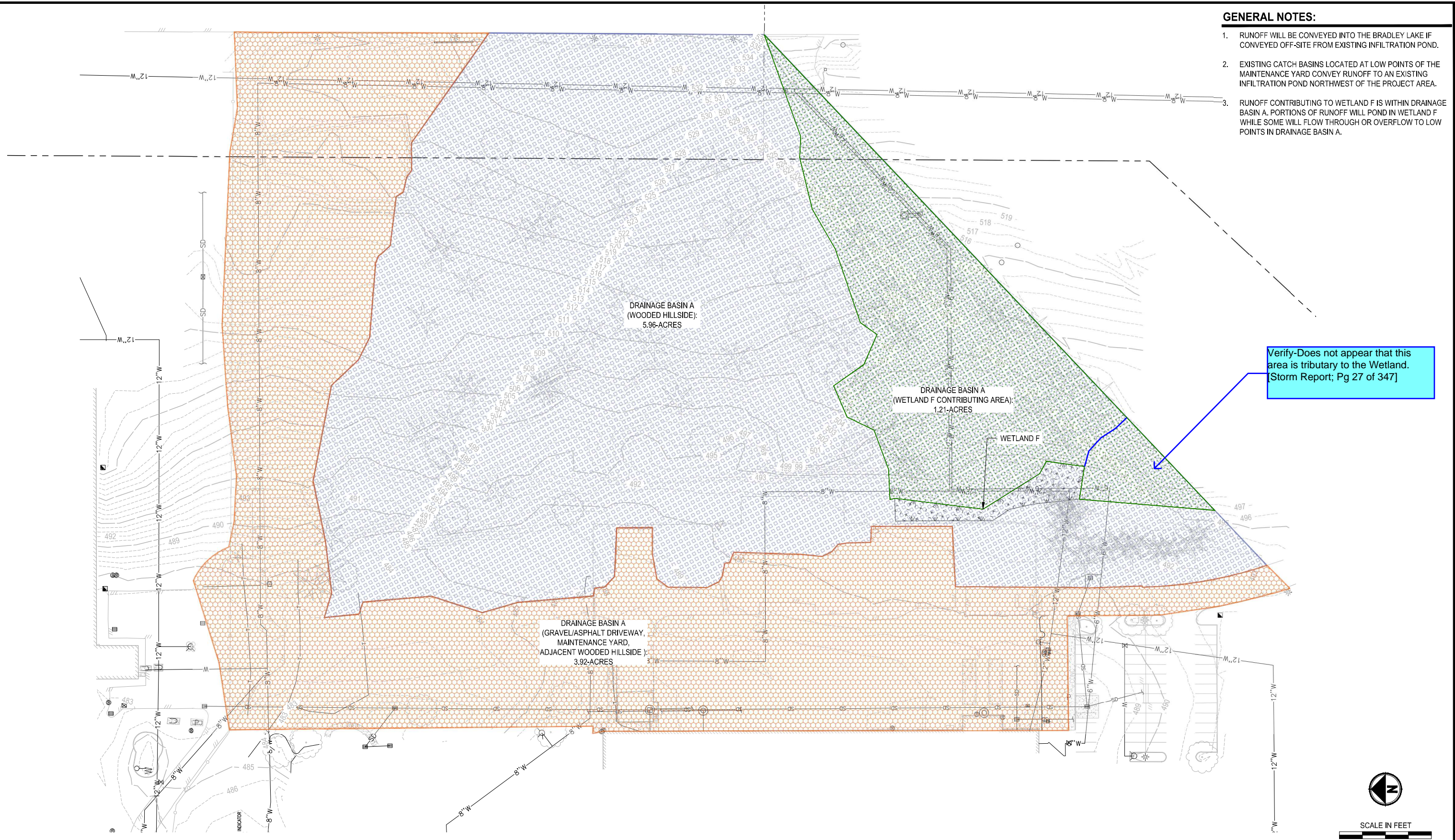

Verify-Does not appear that this area is tributary to the Wetland. (Storm Report; Pg 27 of 347)

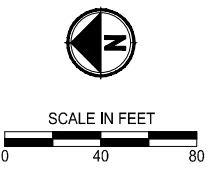

PRELIMINARY

REVISIONS	DATE	BY	DESIGNED

ONE INCH AT FULL SCALE.
 IF NOT, SCALE ACCORDINGLY
 FILE NAME
 JOB No. XX
 DATE FEBRUARY 2022



PROJECT NAME
SOUTH HILL BUSINESS & TECHNOLOGY CENTER PARKING EXPANSION
 PUYALLUP, WA

SHBTC PARKING EXPANSION PRE-DEVELOPMENT DRAINAGE BASIN

DRAWING NO.
 1 OF 2
FIG. 1

PATH: U:\PSO\Projects\Clients\7312-Benaroyo\7312-04_SHB&TCParkingExpansion\02MBS\Stormwater
 LAYOUT: PostDev DB (2)
 PLOTTED BY: Corrowill DATE: Thursday, February 10, 2022 6:31:53 PM

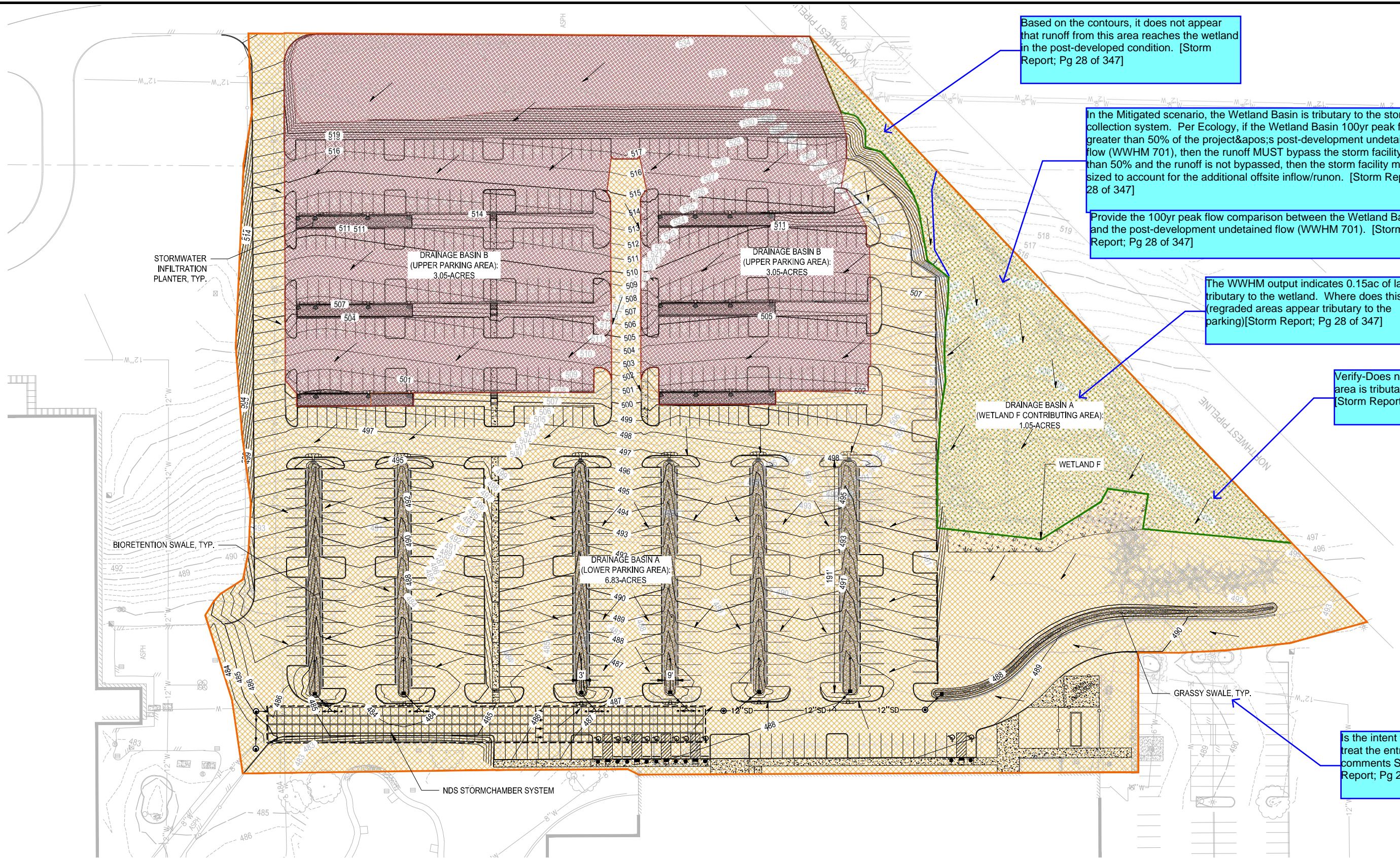

Based on the contours, it does not appear that runoff from this area reaches the wetland in the post-developed condition. [Storm Report; Pg 28 of 347]

In the Mitigated scenario, the Wetland Basin is tributary to the storm collection system. Per Ecology, if the Wetland Basin 100yr peak flow is greater than 50% of the project's post-development undetained flow (WWHM 701), then the runoff MUST bypass the storm facility. If less than 50% and the runoff is not bypassed, then the storm facility must be sized to account for the additional offsite inflow/runon. [Storm Report; Pg 28 of 347]

Provide the 100yr peak flow comparison between the Wetland Basin and the post-development undetained flow (WWHM 701). [Storm Report; Pg 28 of 347]

The WWHM output indicates 0.15ac of lawn tributary to the wetland. Where does this occur? (regarded areas appear tributary to the parking)[Storm Report; Pg 28 of 347]

Verify-Does not appear that this area is tributary to the Wetland. [Storm Report; Pg 28 of 347]

Is the intent to use this swale to treat the entrance road? See comments Sheet SD-03. [Storm Report; Pg 28 of 347]

PRELIMINARY

REVISIONS	DATE	BY	DESIGNED

ONE INCH AT FULL SCALE, IF NOT, SCALE ACCORDINGLY
 FILE NAME
 JOB No. XX
 DATE FEBRUARY 2022

Parametrix
 ENGINEERING · PLANNING · ENVIRONMENTAL SCIENCES

PROJECT NAME
SOUTH HILL BUSINESS & TECHNOLOGY CENTER PARKING EXPANSION
 PUYALLUP, WA

SHBTC PARKING EXPANSION POST-DEVELOPMENT DRAINAGE BASIN

DRAWING NO. 2 OF 2
FIG. 2

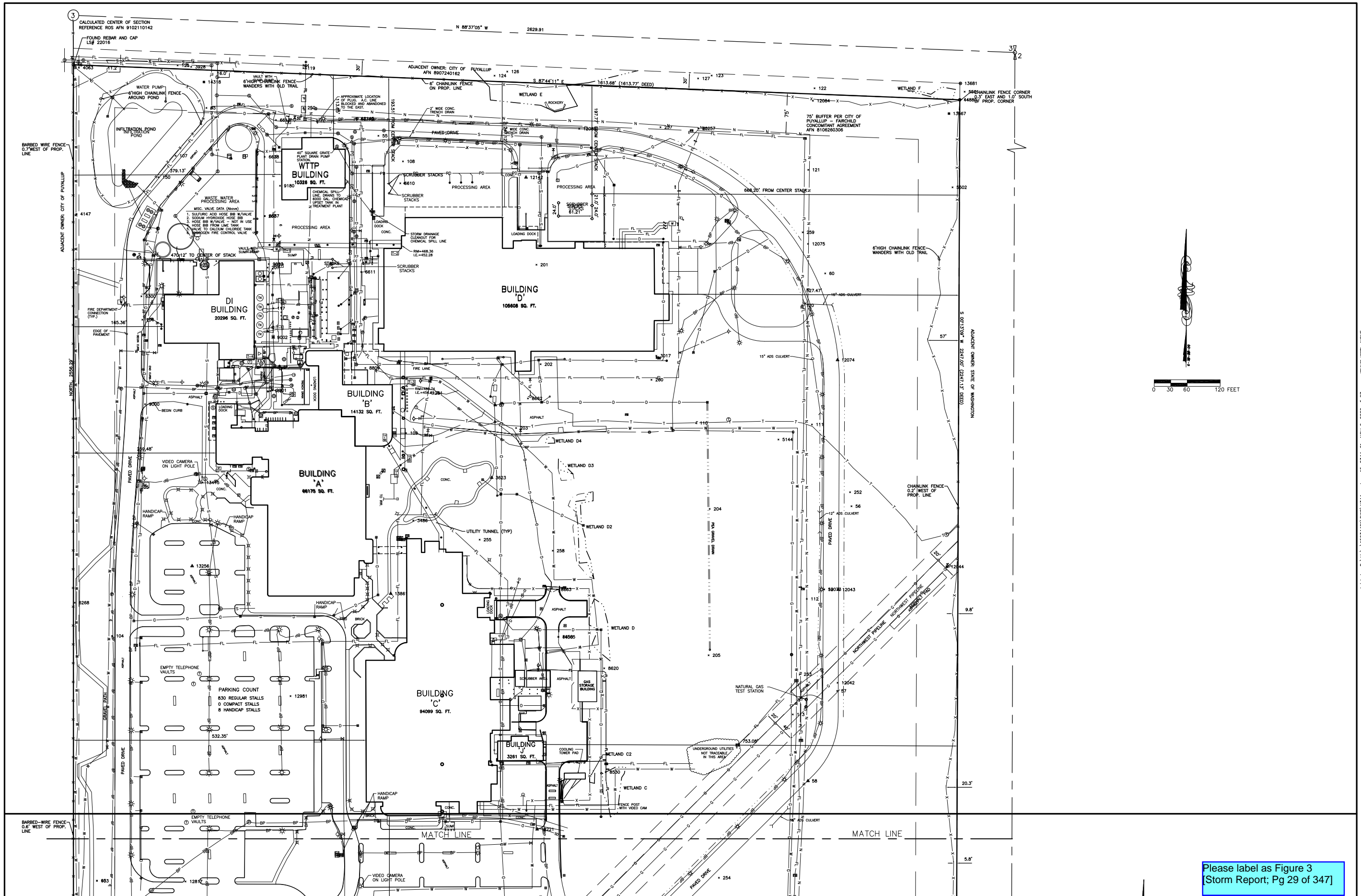

Please label as Figure 3
 Storm Report; Pg 29 of 347

HUITT-ZOLLARS

Land Planning • Civil Engineering • Landscape Architecture • Surveying • Environmental Services
 302 South 9th Street/Suite 104/Tacoma, Wa 98402 • Phone (253)627-9131 • Fax (253)627-4730
 www.huittzollars.com

MICROCHIP TECHNOLOGY INCORPORATED
 CONTACT: SHANNON SKINNER
 PRESTON / GATES / ELLIS LLP.
 701 FIFTH AVENUE, SUITE 5000
 SEATTLE, WA 98104-7078
 (206) 623-7580

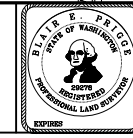

JOB NO. 15-0344-01	REVISIONS:
DATE 06-20-00	7-5-00 PRESTON/GATES/ELLIS
DESIGNED	REVIEW COMMENTS
DRAFTED T.J.N.	
CHECKED BEP	
SCALE 1"=60'	

ALTA/ACSM LAND TITLE SURVEY
 FOR
 MICROCHIP TECHNOLOGY INCORPORATED
 PUYALLUP WA. SITE

DRAWING NO.
 U-2
 SHEET NO.
 4 OF 4

HUITT-ZOLLARS - Plotted by T.J.N.-Tacoma on 06 Nov 2000 - 5:13pm
 attached wfp's NONE
 attached ssm's: \\15034401\SDR\BOUNDARY
 tishale D:\PA\15034401\DWG\344base.dwg 15-0344-01 NOV 6, 2000 5:27 pm

Appendix A

Geotechnical Investigation Report

Geotechnical Engineering Services

East Parking Lot Expansion
South Hill Business and Technology Center
Puyallup, Washington

for

Benaroya Company LLC

February 28, 2022



Geotechnical Engineering Services

East Parking Lot Expansion
South Hill Business and Technology Center
Puyallup, Washington

for

Benaroya Company LLC

February 28, 2022



17425 NE Union Hill Road, Suite 250
Redmond, Washington 98052
425.861.6000

Geotechnical Engineering Services
East Parking Lot Expansion
South Hill Business and Technology Center
Puyallup, Washington

File No. 4565-064-06

February 28, 2022

Prepared for:

Benaroya Company LLC
3600 136th Place SE, Suite 250
Bellevue, Washington 98006

Attention: Mark Johnson

Prepared by:

GeoEngineers, Inc.
17425 NE Union Hill Road, Suite 250
Redmond, Washington 98052
425.861.6000



Bridget A. August, LG, LHG
Hydrogeologist



Debra C. Overbay, PE
Associate

BAA:DCO:nld

Disclaimer: Any electronic form, facsimile or hard copy of the original document (email, text, table, and/or figure), if provided, and any attachments are only a copy of the original document. The original document is stored by GeoEngineers, Inc. and will serve as the official document of record.

Table of Contents

1.0 INTRODUCTION AND PROJECT DESCRIPTION	1
2.0 FIELD EXPLORATIONS AND LABORATORY TESTING	1
2.1. Field Explorations.....	1
2.2. Laboratory Testing	1
3.0 GEOLOGY	1
4.0 SITE CONDITIONS.....	2
4.1. Surface Conditions.....	2
4.2. Subsurface Soil Conditions	2
4.3. Groundwater Conditions.....	3
5.0 CONCLUSIONS AND RECOMMENDATIONS	4
5.1. Summary of Geotechnical Considerations	4
5.2. Earthwork	4
5.2.1. Earthwork Considerations.....	4
5.2.2. Subgrade Preparation	5
5.2.3. Structural Fill Materials.....	5
5.3. Pavement Considerations	7
5.3.1. Subgrade Preparation	7
5.3.2. Pavement Design	7
5.4. Infiltration Considerations	8
5.4.1. Pilot Infiltration Tests	8
5.4.2. Design Infiltration Rates	8
5.5. Drainage Considerations	9
6.0 RECOMMENDED ADDITIONAL GEOTECHNICAL SERVICES.....	9
7.0 LIMITATIONS	10
8.0 REFERENCES	10

LIST OF FIGURES

- Figure 1. Vicinity Map
- Figure 2. Site Plan
- Figure 3. PIT-1-20 Hydrograph
- Figure 4. PIT-1-20 Infiltration Rates
- Figure 5. PIT-2-20 Hydrograph
- Figure 6. PIT-2-20 Infiltration Rates
- Figure 7. PIT-3-20 Hydrograph
- Figure 8. PIT-4-20 Hydrograph
- Figure 9. PIT-4-20 Infiltration Rates
- Figure 10. PIT-5-20 Hydrograph
- Figure 11. PIT-5-20 Infiltration Rates
- Figure 12. PIT-6-20 Hydrograph
- Figure 13. PIT-6-20 Infiltration Rates

APPENDICES

Appendix A. Field Explorations

Figure A-1 – Key to Exploration Logs

Figures A-2 through A-15 – Log of Explorations

Appendix B. Laboratory Testing

Figures B-1 through B-5 – Sieve Analysis Results

Figures B-6 and B-7 – Sieve and Hydrometer Analysis Results

Appendix C. Report Limitations and Guidelines for Use

1.0 INTRODUCTION AND PROJECT DESCRIPTION

This report presents the results of GeoEngineers, Inc.'s (GeoEngineers) geotechnical engineering services for the proposed East Parking Lot project at the South Hill Business and Technology Center in Puyallup, Washington. We previously provided geotechnical engineering services and infiltration testing for the proposed parking lot in 2014. We understand the size of the proposed parking area has increased to include the wooded area to the east, extending roughly 500 square feet.

The project location is shown on the attached Vicinity Map, Figure 1. The purpose of this study was to complete additional infiltration testing for potential low impact development (LID) drainage features, complete explorations to evaluate subsurface conditions in the undeveloped wooded area, and to provide geotechnical recommendations for support of the parking lot expansion. Our geotechnical engineering services were completed in general accordance with the confirming agreement executed on March 30, 2020. We submitted a draft report on February 5, 2021. This final report incorporates a revised site plan.

2.0 FIELD EXPLORATIONS AND LABORATORY TESTING

2.1. Field Explorations

Subsurface soil and groundwater conditions were evaluated by excavating 11 test pits (TP-1-20 through TP-5-20 and PIT-1-20 through PIT-6-20) and advancing three borings (MW-1-20, MW-2-20 and B-3) at the approximate locations shown on the attached Site Plan, Figure 2. The test pits were completed to depths ranging from 7½ to 10 feet below the ground surface (bgs). The borings were advanced to depths between 11.5 and 26.5 feet bgs.

Pilot infiltration tests (PITs) were completed in six of the test pits (PIT-1-20 through PIT-6-20) at a depth of 4 feet. Two of the borings (MW-1-20 and MW-2-20) were completed as monitoring wells. A detailed description of the field exploration and testing program and logs of the explorations are presented in Appendix A, Field Explorations. The results of the PITs are also presented in the main text of this report.

2.2. Laboratory Testing

Soil samples obtained from the explorations were transported to GeoEngineers' Redmond, Washington geotechnical laboratory and evaluated to confirm or modify field classifications, as well as to evaluate engineering and index properties of the soil. Selected samples were tested for the determination of moisture content, grain size distribution, percent fines and organic content. Select soil samples were also sent to an outside laboratory for cation exchange capacity (CEC) analysis. A description of the laboratory testing and the test results are presented in Appendix B, Laboratory Testing.

3.0 GEOLOGY

We reviewed available geologic maps, including the geologic map of the Tacoma quadrangle (Schuster et al. 2015). The project area is located on a glaciated upland west and south of a major glacial trough, now occupied by the Puyallup River.

Surficial soils mapped in the project vicinity generally consist of geologic units deposited during the Vashon stade of the Fraser glaciation and include Vashon Till (Got), Recessional outwash (Qgo) and ice-contact deposits (Qgoi).

Vashon till generally consists of a non-sorted, non-stratified mixture of clay, silt, sand and gravel with larger constituents up to the size of cobbles and boulders. The till is very dense and relatively impermeable but can contain localized zones of interbedded stratified sand and gravel.

Recessional outwash and ice-contact deposits typically consist of stratified outwash sand with some gravel, and some areas of silt and clay. The sediments were deposited by meltwater from the stagnating and receding Vashon glacier and are typically loose to medium dense.

Subsurface soils encountered in our explorations are consistent with the geologic mapping. In general, we encountered a variable thickness of fill overlying recessional outwash/ice contact deposits. Glacial till was encountered at depth in the borings below a depth of approximately 20 to 25 feet bgs.

4.0 SITE CONDITIONS

4.1. Surface Conditions

The South Hill Business and Technology Center is located north of 39th Avenue SE, east of Bradley Lake and west of Pierce College in Puyallup, Washington. College Way borders the site to the north. The East Parking Lot expansion area is located in the east-central portion of the Business and Technology Center campus. The southwest portion of the parking lot expansion area consists of a gravel parking/yard area located adjacent to the existing south building as shown in Figure 2. The existing gravel area is relatively level with existing ground surface elevations ranging from Elevation 486 feet in the west and Elevation 491 feet in the east (elevations in this report refer to the North American Vertical Datum of 1988 [NAVD 88]). The north and east portions of the proposed parking lot expansion area consist of an undeveloped wooded area that slopes upward to the east to approximately Elevation 520 feet. This area contains fir and cedar trees with a dense understory of blackberry vines.

4.2. Subsurface Soil Conditions

Soils encountered in the explorations are generally consistent with the mapped geologic units. Soils encountered in the explorations on the western portion generally consist of fill overlying complex layering of recessional outwash/ice contact deposits. The near-surface deposits generally consist of medium dense silty sand with variable gravel content. Cobbles were observed within the deposits in PIT-3-20 and PIT-6-20. The silty sand was encountered below the infiltration subgrade in the southwestern explorations, which resulted in limited to no infiltration as described in a subsequent section.

Subsurface soils encountered in PIT-5-20 and PIT-6-20 excavated in the eastern undeveloped area contained layers of cleaner sand and gravel that extended to the full depth of the test pits. Moderate to high infiltration rates were obtained in these explorations as discussed in Section 5.4.

The borings were advanced up to a depth of 26.5 feet below the existing ground surface and encountered dense to very dense silty sand with gravel below a depth of 20 to 25 feet (interpreted as glacial till). Shallow monitoring wells were installed in the borings to monitor groundwater conditions.

Vashon till consists of dense to very dense silty sand with gravel, cobbles, and occasional boulders.

4.3. Groundwater Conditions

Groundwater seepage was observed in test pits TP-4-20 and TP-5-20 located in the southeast corner of the site at depths of 6 and 8½ feet, respectively. Groundwater seepage was also observed in PIT-3-20 and PIT-4-20 at depths of 2 and 3¾ feet, respectively, prior to PIT testing. A summary of groundwater observations in all explorations is provided in Table 1. Groundwater levels should be expected to fluctuate seasonally and following significant rain events.

TABLE 1. GROUNDWATER OBSERVATIONS AND MEASUREMENTS

Exploration	Observed Seepage Depth ¹ (During Excavation/Drilling) (feet)	Observed Seepage Depth Following PIT Test ² (feet)	Measured Groundwater Depth (feet), Date
TP-1-20	Not Encountered	-	-
TP-2-20	Not Encountered	-	-
TP-3-20	Not Encountered	-	-
TP-4-20	6	-	-
TP-5-20	8½	-	-
PIT-1-20	Not Encountered	Not Encountered	-
PIT-2-20	Not Encountered	Not Encountered	-
PIT-3-20	2	Not Encountered	-
PIT-4-20	3¾	Not Encountered	-
PIT-5-20	Not Encountered	Not Encountered	-
PIT-6-20	Not Encountered	6	-
MW-1	15	-	15.30, 12/18/20
MW-1			10.61, 5/7/21
MW-2	13	-	8.55, 12/18/20
MW-2			5.61, 5/7/21

Notes:

¹ Groundwater levels observed during excavation/drilling should be considered approximate due to the limited time the exploration is left open.

² Although seepage was not observed following the PIT test, PIT-1-20 through PIT-3-20 had zero infiltration as discussed in Section 5.4.

5.0 CONCLUSIONS AND RECOMMENDATIONS

5.1. Summary of Geotechnical Considerations

We conclude that the planned improvements can be successfully completed from a geotechnical perspective, provided the considerations and recommendations presented in this report are incorporated into the project. A summary of the primary geotechnical considerations is provided below. The summary is presented for introductory purposes only and should be used in conjunction with the complete recommendations presented in this report.

- The surficial silty sand soils contain a high percentage of fines (that portion passing the U.S. No. 200 sieve) and are therefore susceptible to disturbance when wet. Care should be taken to avoid allowing these soils to become saturated and disturbed. We recommend earthwork be completed in the dry season, if practical, to reduce subgrade stabilization measures and import/export quantities.
- Based on our understanding of subsurface conditions at the site and our experience, we recommend a minimum pavement section consisting of 3 inches of asphalt concrete overlying 6 inches of crushed surfacing base course (CSBC) for drive aisles and light-duty service vehicles. A minimum pavement section consisting of 2 inches of asphalt concrete overlying 4 inches of CSBC is appropriate for areas restricted to automobile parking. A granular subbase is also recommended to provide pavement drainage and a stable subgrade for pavement support. Subbase material should consist of a minimum 6-inch thickness of gravel borrow as described in Section 5.3 “Pavement Considerations.” This minimum thickness assumes construction occurs during dry weather and the subgrade can be compacted to at least 95 percent of the maximum dry density (MDD) prior to placement. Additional thickness will be required where loose, wet soils are encountered.
- We anticipate that portions of the on-site soils may be suitable for reuse as fill during dry weather only. Imported structural fill will be necessary during wet weather and when the existing soils are too wet to achieve compaction. We recommend the suitability of the exposed soils be evaluated during construction when they are exposed and a contingency be planned to use imported structural fill. Structural fill recommendations are described in Section 5.2.3. “Structural Fill Materials.”
- We understand that stormwater infiltration drainage features are being considered for the site. We also understand that the infiltration facilities will be designed in accordance with the Washington State Department of Ecology Stormwater Management Manual of Western Washington (SMMWW) (Ecology 2019). Testing results of PITs completed in the southwest portion of the site resulted in no infiltration. Infiltration rates obtained in PITs completed in the undeveloped area range from 0.2 to 5.7 (corrected), with the greatest infiltration at PIT-5-20 and PIT-6-20. Groundwater was measured more than 5.6 feet below the existing ground surface in the monitoring wells installed within the undeveloped area.

These and other geotechnical considerations and recommendations are discussed further in the following sections of this report.

5.2. Earthwork

5.2.1. Earthwork Considerations

We anticipate site development and earthwork activities will include clearing and stripping vegetated areas; demolition of existing hardscaping or site facilities, as needed; site grading; establishing subgrades for drive

aisles and parking areas; installation of utilities; installation of infiltration facilities; and placing and compacting fill and backfill materials. We expect site grading and earthwork can be accomplished with conventional earthmoving equipment. Cobbles were observed in the test pits and boulders are also common in glacial deposits. The contractor should be prepared to handle/remove cobbles and boulders.

Existing surfaces within proposed development areas should be cleared and stripped of all vegetation and organics prior to site development. Minimum stripping depths at the site will likely be on the order of 2 to 10 inches. Greater stripping depths should be anticipated to remove localized root systems of shrubs and trees within the undeveloped area. Voids caused by removal of stumps and/or root systems should be backfilled with compacted structural fill.

Based on our explorations, we anticipate soils exposed after stripping will have a high fines content and thus be susceptible to disturbance when wet. Care should be taken to avoid allowing these soils to become saturated and disturbed. We provide recommendations for subgrade protection in Section 5.2.3.3.

5.2.2. Subgrade Preparation

Prior to placing new fill, subbase or base course materials, larger subgrade areas should be proof-rolled to locate areas of loose, soft or pumping soils. Smaller subgrade areas should be evaluated by probing. Proof-rolling can be completed using a piece of heavy tire-mounted equipment or a loaded dump truck.

Where soft or pumping soils are observed, the subgrade soils should be recompacted or overexcavated and replaced. The depth of overexcavation should be determined by GeoEngineers based on the exposed conditions during construction. It may be possible to limit excavation depths by placing a geotextile for separation or soil stabilization on the subgrade (Washington State Department of Transportation [WSDOT] Standard Specification 9-33.2). We recommend using the specified woven fabric for soil stabilization (Table 3 of 9-33.2). The geotextile should be pulled taut and placed such that there are no folds or wrinkles. Adjacent geotextile panels should be overlapped a minimum of 1.5 feet. The first loose lift of fill placed over the geotextile should be a minimum of 12 inches thick and spread uniformly with a dozer. Equipment should not be routed directly on the geotextile or when there is less than 12 inches of cover. The geotextile will provide additional support by bridging over the soft material, and will help reduce fines contamination into the structural fill. The need for geotextile fabric and overexcavation should be evaluated based on observed conditions and depth of disturbance during construction.

GeoEngineers should monitor subgrade preparation operations to help determine the depth of removal of soft or pumping soils, and to evaluate whether subgrade disturbance or progressive deterioration is occurring. Subgrade disturbance or deterioration could occur if the subgrade is wet and cannot be dried. If the subgrade deteriorates during proof-rolling or compaction, it may become necessary to modify the proof-rolling or compaction criteria or methods.

5.2.3. Structural Fill Materials

Materials placed to support pavement is classified as structural fill for the purpose of this report. Structural fill material quality varies depending upon its use, as described below:

1. As a minimum, structural fill placed beneath pavement and to backfill utility trenches should meet the criteria for common borrow, WSDOT 9-03.14(3). Common borrow will be suitable for use as structural fill during dry weather conditions only and should be conditioned to within 2 percent of its optimum

moisture content. If structural fill is placed during wet weather, the structural fill should consist of gravel borrow, WSDOT 9-03.14(1) with the added restriction that the material passing the U.S. No. 200 sieve should be limited to 5 percent.

2. Structural fill placed as subbase below the CSBC should consist of gravel borrow. Gravel borrow should conform to WSDOT 9-03.14(1) with the added restriction that the material passing the U.S. No. 200 sieve should be limited to 5 percent.
3. Structural fill placed as CSBC should conform to WSDOT 9-03.9(3) with the exception that it contain less than 5 percent passing the U.S. No. 200 sieve.

5.2.3.1. On-site Soils

The soils observed in the explorations generally contain a high percentage of fines (silt and clay) and are moisture-sensitive. Some of the on-site soils may meet the criteria for common borrow and may be suitable for use during dry weather construction only, provided the soil has a moisture content near optimum. Fine-grained soils (silt and clay), or soils with wood or other debris do not meet the criteria for common borrow and should not be used.

5.2.3.2. Fill Placement and Compaction Criteria

Structural fill should be mechanically compacted to a firm and non-yielding condition. Structural fill should be placed in loose lifts not exceeding 1 foot in thickness. Each lift should be conditioned to the proper moisture content and compacted to the specified density before placing subsequent lifts. Structural fill should be compacted to the following criteria:

1. Structural fill beneath new pavement and storm drainage structures should be compacted to 90 percent of the MDD (ASTM International [ASTM] D 1557), except that the upper 2 feet of fill below final subgrade should be compacted to 95 percent of the MDD (ASTM D 1557).
2. Structural fill placed as CSBC below pavements should be compacted to 95 percent of the MDD (ASTM D 1557).

As discussed previously, we recommend that a representative of GeoEngineers be present during proof-rolling and/or probing of the exposed subgrade and pavement subgrade soils, and during placement of structural fill. GeoEngineers will evaluate the adequacy of the subgrade soils and identify areas needing further work, providing remediation recommendations as necessary. GeoEngineers will also perform in-place moisture-density tests of structural fill to evaluate whether the work is being done in accordance with the compaction specifications, and advise on any modifications to procedure that may be appropriate for the prevailing conditions.

5.2.3.3. Weather Considerations

The majority of surficial on-site soils generally contain a high percentage of fines (silt and clay) and are moisture-sensitive. When the moisture content of these soils is more than a few percent above the optimum moisture content, these soils become muddy and unstable, operation of equipment on these soils will be difficult, and it will be difficult or impossible to meet required compaction criteria. Disturbance of near-surface soils should be expected if earthwork is completed during periods of wet weather. The contractor will need to take precautions to protect the subgrade during periods of wet weather.

The wet weather season in western Washington generally begins in October and continues through May; however, periods of wet weather may occur during any month of the year. The optimum earthwork period

for these types of soils is typically June through September. If wet weather earthwork is unavoidable, we recommend the following:

- The ground surface in and around the work area should be sloped so that surface water is directed away from the work area. The ground surface should be graded such that areas of ponded water do not develop. The contractor should take measures to prevent surface water from collecting in excavations and trenches. Measures should be implemented to remove surface water from the work area.
- Erosion control techniques should be implemented to prevent sediment from leaving the site.
- Earthwork activities should not take place during periods of heavy precipitation.
- Slopes with exposed soils should be covered with plastic sheeting.
- The contractor should take necessary measures to prevent on-site soils and soils to be used as fill from becoming wet or unstable. These measures may include the use of plastic sheeting, sumps with pumps, and grading. The site soils should not be left uncompacted and exposed to moisture. Sealing the surficial soils by rolling with a smooth-drum roller prior to periods of precipitation will help reduce the extent that these soils become wet or unstable.
- Construction activities should be scheduled so that the length of time that soils are left exposed to moisture is reduced to the extent practical.

5.3. Pavement Considerations

5.3.1. Subgrade Preparation

Pavement subgrade areas should be prepared as recommended in Section 5.2.2. “Subgrade Preparation.” If construction occurs during the wet season, we estimate up to 18 inches of subbase overlying a geotextile may be required to provide a stabilized subgrade where grading occurs in the undeveloped area. Subbase fill should consist of gravel borrow as previously discussed. The subbase can be reduced to 6 inches if construction occurs during the dry season and the subgrade can be compacted to a minimum of 95 percent of the MDD. Isolated areas of thicker subbase may be required during the dry season where the existing soils are loose or wet and cannot be compacted. The required excavation thickness will depend on the moisture content of the subgrade soils at the time of construction and should be evaluated at that time.

If soft or pumping soils are observed within the prepared subgrade, subgrade soils should be recompacted or overexcavated and replaced. A woven geotextile could also be considered to limit overexcavation. Recommended overexcavation, geotextile and geotextile placement methods are provided in Section 5.2.2 “Subgrade Preparation.”

5.3.2. Pavement Design

We recommend the following pavement design sections based on our understanding of subsurface conditions at the site, discussions with the design team, and our previous experience in the area.

TABLE 2. DESIGN PAVEMENT SECTIONS

Design Section	Asphalt Surfacing Thickness ¹ (inches)	Crushed Surfacing Base Course ² (inches)	Wet Weather Subbase Gravel Borrow ³ (inches)	Dry Weather Subbase Gravel Borrow ³ (inches)
Light-Duty Service Vehicles and Drive Aisles	3	6	12 to 18	6
Automobile Parking	2	4	12 to 18	6

Notes:

¹ Asphalt surfacing should consist of ½-inch HMA in accordance with WSDOT Specifications Sections 5-04 and 9-03.

² CSBC should meet WSDOT Specification 9-03.9(3) with the exception that it contain less than 5 percent passing the U.S. No. 200 sieve.

³ The above pavement recommendations assume subgrade preparation to obtain CBR of approximately 15. If site preparation occurs during the wet season, a thick subbase is recommended for subgrade stabilization (12- to 18-inch layer of gravel borrow overlying a woven geotextile). The subbase can be reduced to 6 inches during dry weather provided the subgrade can be compacted to a minimum of 95 percent of the MDD. Gravel borrow should meet WSDOT Standard Specification 9-03.14(1) with the exception it contain less than 5 percent passing the U.S. No. 200 sieve.

5.4. Infiltration Considerations

We understand that stormwater infiltration drainage features are being considered for the site. Initial saturated hydraulic conductivity (K_{sat}) values were determined for site soils using in-situ PITs, as described below. We understand that infiltration features will be approximately 4 feet below grade.

5.4.1. Pilot Infiltration Tests

Six small-scale PITs were conducted in test pits PIT-1-20 through PIT-6-20 within the footprint of the proposed parking lot expansion area at the locations shown in Figure 2. The PITs were completed in general accordance with the guidelines provided in the SMMWW.

For all six PITs, a graduated yard stick was driven into the floor of each test pit as a visual reference for monitoring water levels during testing. A piezoelectric pressure transducer was secured to the bottom of the yard stick to provide accurate water level records in 5-second intervals throughout the duration of the tests. Full water-level records recorded for each test are plotted on Figures 3, 5, 7, 8, 10, and 12.

Detailed descriptions of the PIT “pre-soak” and testing phases are described in Appendix A. The plots of apparent PIT Infiltration rate for successive stages of each test (Figures 4, 6, 9, 11, and 13) provide a visual confirmation of subgrade saturation as infiltration rates decline to asymptotic steady-state values toward the end of the pre-soaking period when the water depth is maintained between 12 to 14 inches. The measured infiltration rates determined during the testing phase are assumed to approximate the saturated (vertical) hydraulic conductivity of the test pit subgrade.

5.4.2. Design Infiltration Rates

Three correction factors are applied to $K_{sat\ initial}$ to calculate the design saturated hydraulic conductivity ($K_{sat\ design}$) as required by the SMMWW. The correction factors consider the site variability and number of locations tested (CF_v), the testing method (CF_t), and the degree of influent control to prevent siltation and bio buildup (CF_m). CF_t accounts for uncertainties in the testing methods and is equal to 0.5 for small-scale PITs. CF_m accounts for the clogging effect of suspended material in stormwater, which will cause the soil’s

initial infiltration rate to gradually decline. The maintenance schedule calls for removing sediment when the Best Management Practices (BMP) is infiltrating at only 90 percent of its design capacity, so CF_m is equal to 0.9. CF_v can vary between 0.33 to 1.0 based on the variability of the soils on the site. CF_v was set to 0.8 for the three PITs located in the undeveloped area of the site (PIT-4-20 to PIT-6-20 in Table 3 below).

The design saturated hydraulic conductivity is calculated by:

$$K_{sat\ design} = K_{sat\ initial} \times CF_v \times CF_t \times CF_m$$

Additional details of the infiltration testing is included in Appendix A. All correction factors and hydraulic conductivities are shown in Table A-1 and Table 3.

TABLE 3. INFILTRATION RATES FROM PILOT INFILTRATION TESTING

PIT	$K_{sat\ initial}$ (inches per hour)	CF_v^1	CF_t^2	CF_m^3	$K_{sat\ design}$ (inches per hour)
PIT-1-20	0	-	-	-	0
PIT-2-20	0	-	-	-	0
PIT-3-20	NA	-	-	-	NA ⁴
PIT-4-20	0.5	0.8	0.5	0.9	0.2
PIT-5-20	8.0	0.8	0.5	0.9	2.9
PIT-6-20	15.9	0.8	0.5	0.9	5.7

Notes:

- ¹ Site variability and number of locations tested. $CF_v = 0.33$ to 1.0
- ² Test method. $CF_t = 0.5$ for small-scale PITs
- ³ Degree of influent control to prevent siltation and bio-buildup. $CF_m = 0.9$
- ⁴ NA, PIT-3-20 could not be analyzed due to groundwater seepage entering the test pit excavation during testing

5.5. Drainage Considerations

We anticipate shallow groundwater seepage may enter construction excavations depending on the time of year and weather conditions. We anticipate localized dewatering can be adequately handled by pumping from sumps within the bottom of excavations augmented with gravel-lined trenches. The excavation for the sump and the drainage trenches should be backfilled with clean gravel or crushed rock to reduce the amount of sediment in the water pumped from the sump (i.e., to serve as a filter). If seepage is not intercepted and removed from excavations, it will be difficult to place and compact structural fill and may result in destabilized cut slopes.

All paved and landscaped areas should be graded so that surface drainage is directed away from the building to appropriate catch basins.

6.0 RECOMMENDED ADDITIONAL GEOTECHNICAL SERVICES

GeoEngineers should be retained to review the project plans and specifications when complete to confirm that our design recommendations have been implemented as intended. Care must be taken during construction to protect the infiltration surface below the parking areas by avoiding surface compaction from

vehicle traffic or excavation equipment, avoiding flooding of the area, and preventing the run-on and ponding of silt laden stormwater from adjacent areas of the site.

During construction, GeoEngineers should observe stripping and grading, observe installation of subsurface drainage measures, evaluate the suitability of infiltration subgrades and other appurtenant structures, and provide a summary letter of our construction observation services. The purposes of GeoEngineers construction phase services are to confirm the subsurface conditions are consistent with those observed in the explorations and other reasons described in Appendix C, Report Limitations and Guidelines for Use.

7.0 LIMITATIONS

We have prepared this report for the exclusive use of the Benaroya Company LLC and other project team members for the East Parking Lot Expansion project at the South Hill Business and Technology Center in Puyallup, Washington. The data should be provided to prospective contractors for their bidding or estimating purposes, but our report and interpretations should not be construed as a warranty of the subsurface conditions.

Within the limitations of scope, schedule and budget, our services have been executed in accordance with generally accepted practices in the field of geotechnical engineering in this area at the time this report was prepared. No warranty or other conditions, express or implied, should be understood.

Please refer to Appendix C for additional information pertaining to use of this report.

8.0 REFERENCES

American Association of State Highway and Transportation Officials (AASHTO), AASHTO Guide for Design of Pavement Structures, 1993.

ASTM International (ASTM), 2020 Annual Book of ASTM Standards, 2020.

Schuster, J. E., Cabibbo, A. A., Schilter, J. F., Hubert, I. J., 2015, "Geologic Map of the Tacoma 1:100,000-scale Quadrangle, Washington."

Washington State Department of Ecology, "Stormwater Management in Western Washington, Volume V, Runoff Treatment, Flow Control, and LID BMP Library," July 2019.

Washington State Department of Transportation, Standard Specifications for Road, Bridge and Municipal Construction, 2020.

Washington State Department of Transportation, WSDOT Pavement Policy, June 2015.

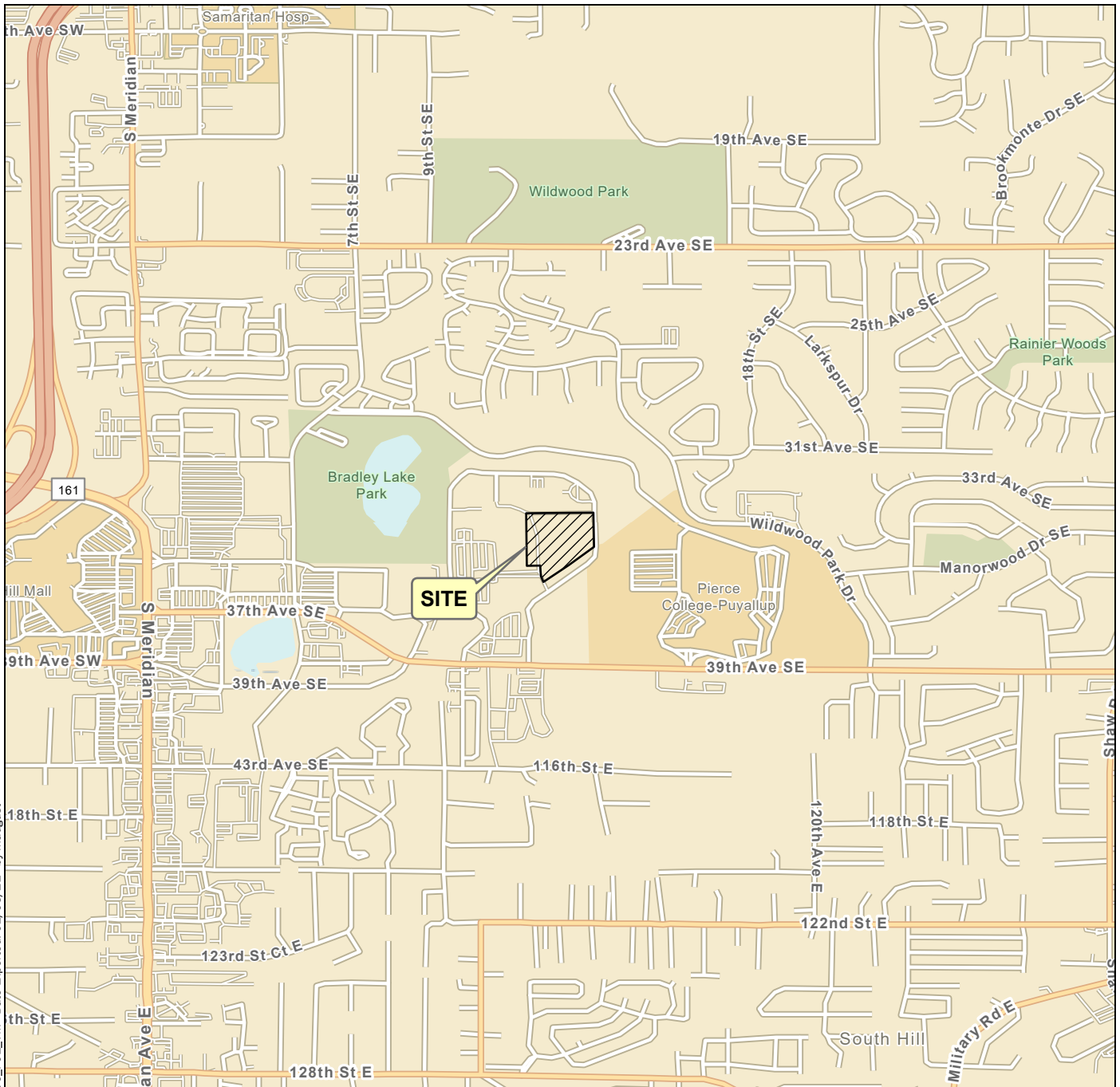

P:\4565064\06_GIS\456506406_Project.aprx 456506406_Project.aprx 456506406_F01_VM Date Exported: 02/05/21 by maugust

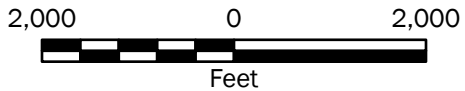
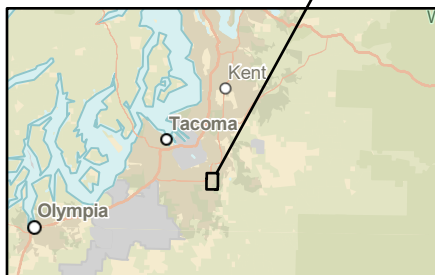

Vicinity Map

**Benaroya Co South Hill Business & Technology Center
Puyallup, Washington**



Figure 1

Notes:

1. The locations of all features shown are approximate.
2. This drawing is for information purposes. It is intended to assist in showing features discussed in an attached document. GeoEngineers, Inc. cannot guarantee the accuracy and content of electronic files. The master file is stored by GeoEngineers, Inc. and will serve as the official record of this communication.

Data Source: ESRI
Projection: NAD 1983 StatePlane Washington South FIPS 4602 Feet

P:\4565064\CAD\06\GeoTech\456506406_F02_Site Plan.dwg TAB:F02 Date Exported: 02/18/22 - 4:38 by syi

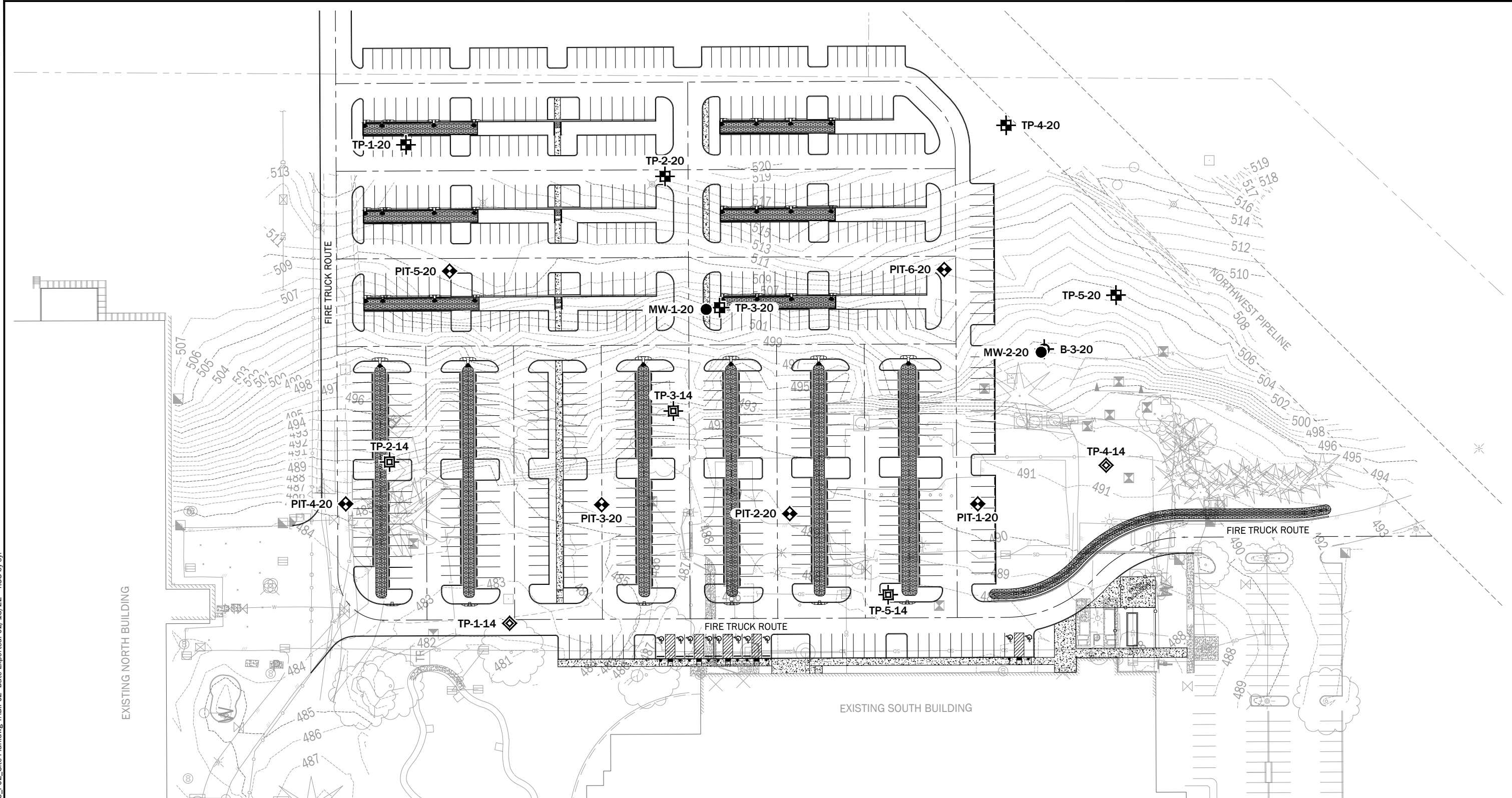

Notes:
 1. The locations of all features shown are approximate.
 2. This drawing is for information purposes. It is intended to assist in showing features discussed in an attached document. GeoEngineers, Inc. cannot guarantee the accuracy and content of electronic files. The master file is stored by GeoEngineers, Inc. and will serve as the official record of this communication.

Data Source: Base CAD file from Parametrix received on 2/16/2022.
 Projection: WA State Plane, South Zone, NAD83, US Foot

- Legend**
- MW-1-20 ● Monitoring Well by GeoEngineers, Inc., 2020
 - B-3-20 ⊕ Boring by GeoEngineers, Inc., 2020
 - TP-1-20 ⊕ Test Pit by GeoEngineers, Inc., 2020
 - PIT-1-20 ◆ Pilot Infiltration Test by GeoEngineers, Inc., 2020
 - TP-2-14 ⊕ Test Pit by GeoEngineers, Inc., 2014
 - TP-1-14 ◆ Pilot Infiltration Test by GeoEngineers, Inc., 2014
 - ▨ Potential Infiltration Facilities

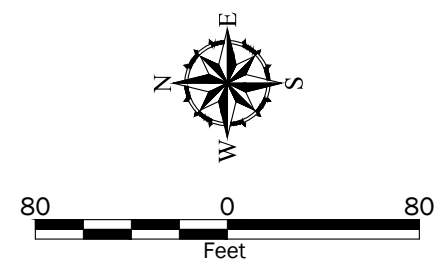

Site Plan	
Benaroya Co South Hill Business & Technology Center Puyallup, Washington	
	Figure 2

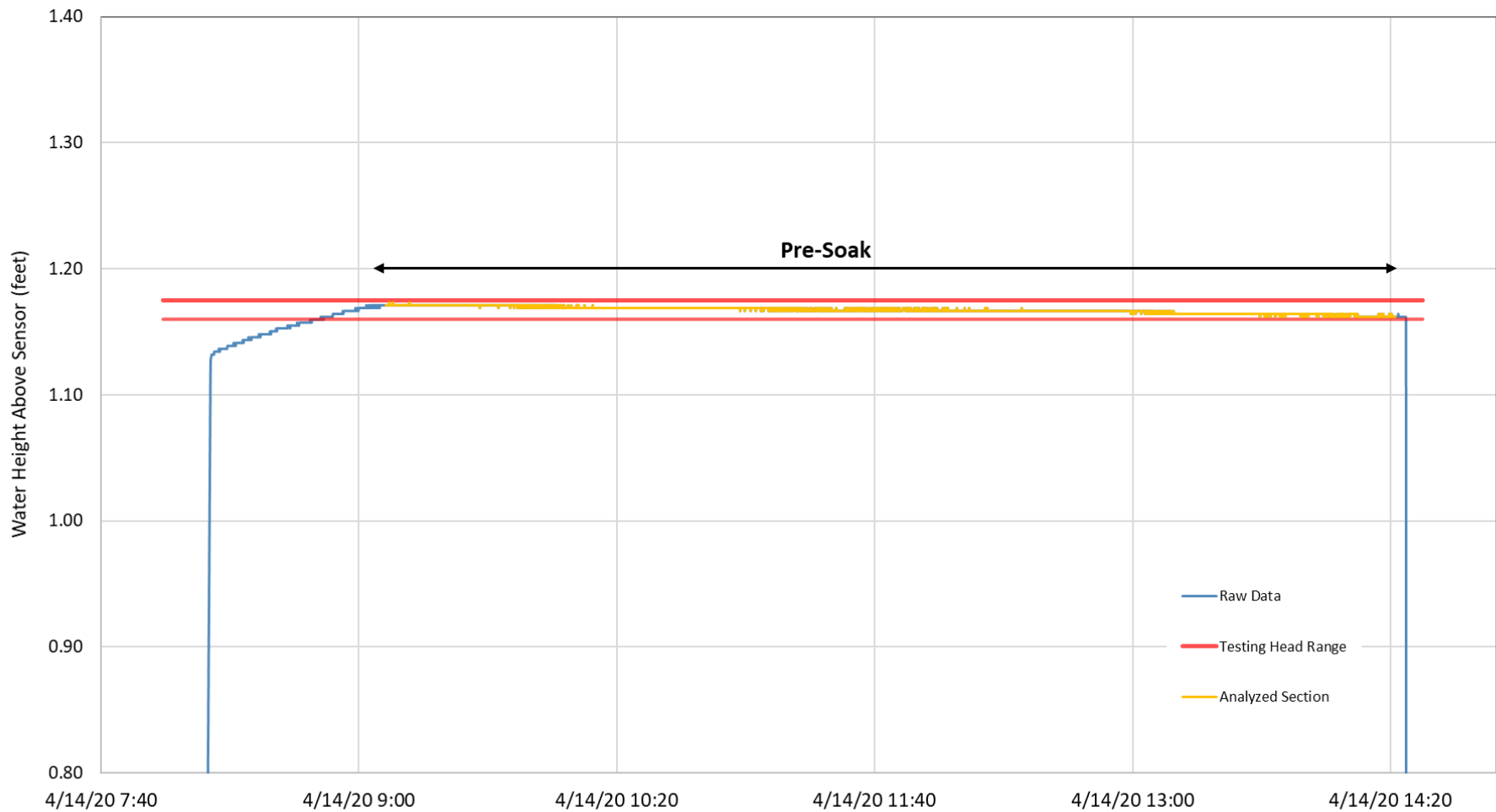

Notes:

1. PIT-1-20 was started on April 14, 2020.
2. PIT-1-20 was aborted due to lack of infiltration on April 14, 2020.
3. The testing phase head range was analyzed during the pre-soak period.

PIT-1-20 Hydrograph

Benaroya Co South Hill Business & Technology Center
Puyallup, Washington



Figure 3

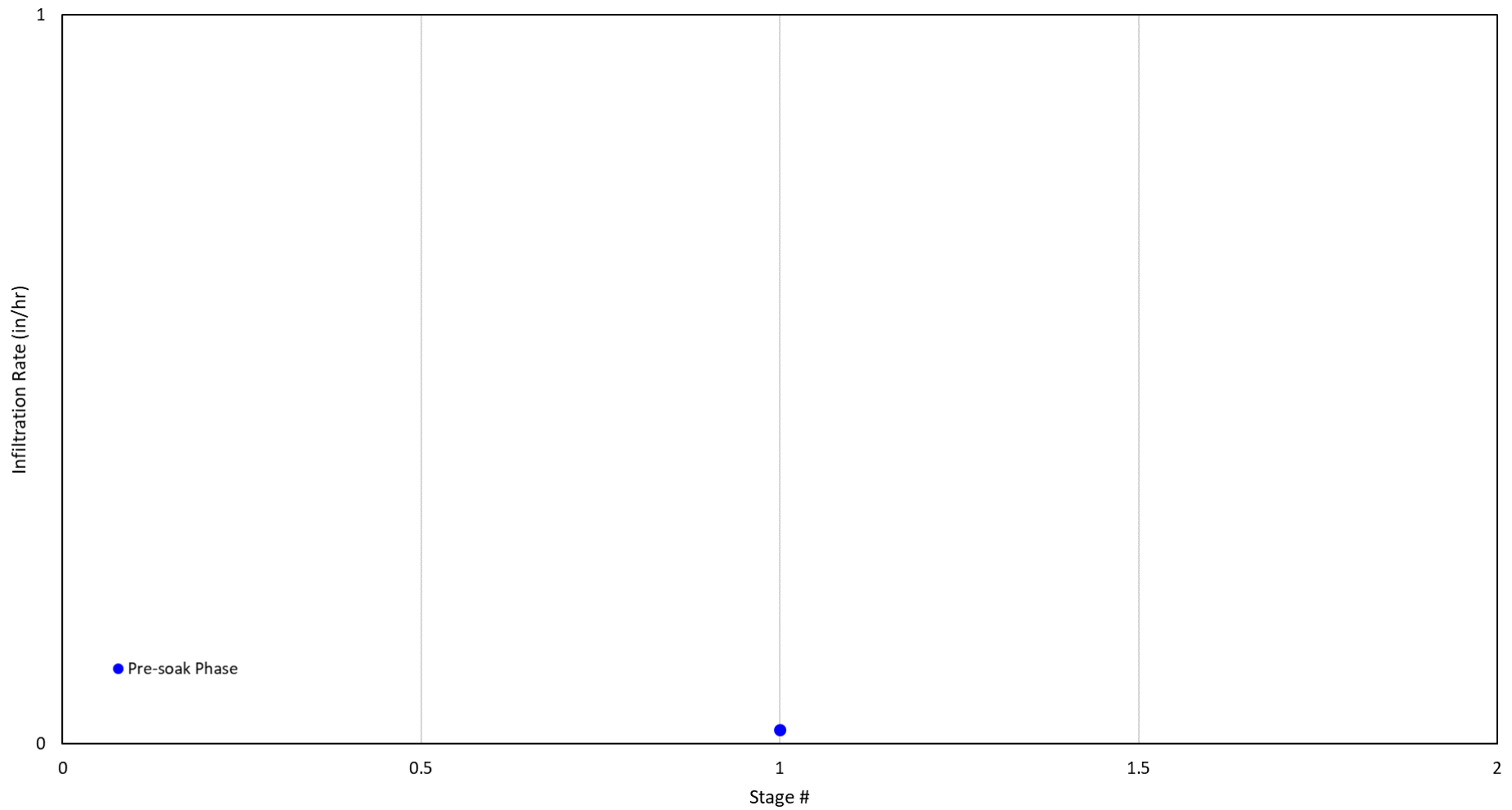

Notes:

1. The pre-soak period is intended to saturate the soil and is not taken to be the long-term infiltration rate.
2. The estimated field measured infiltration rate is 0.02 inches per hour based on the geometric mean of the pre-soak phase.

PIT-1-20 Infiltration Rates

Benaroya Co South Hill Business & Technology Center
Puyallup, Washington



Figure 4

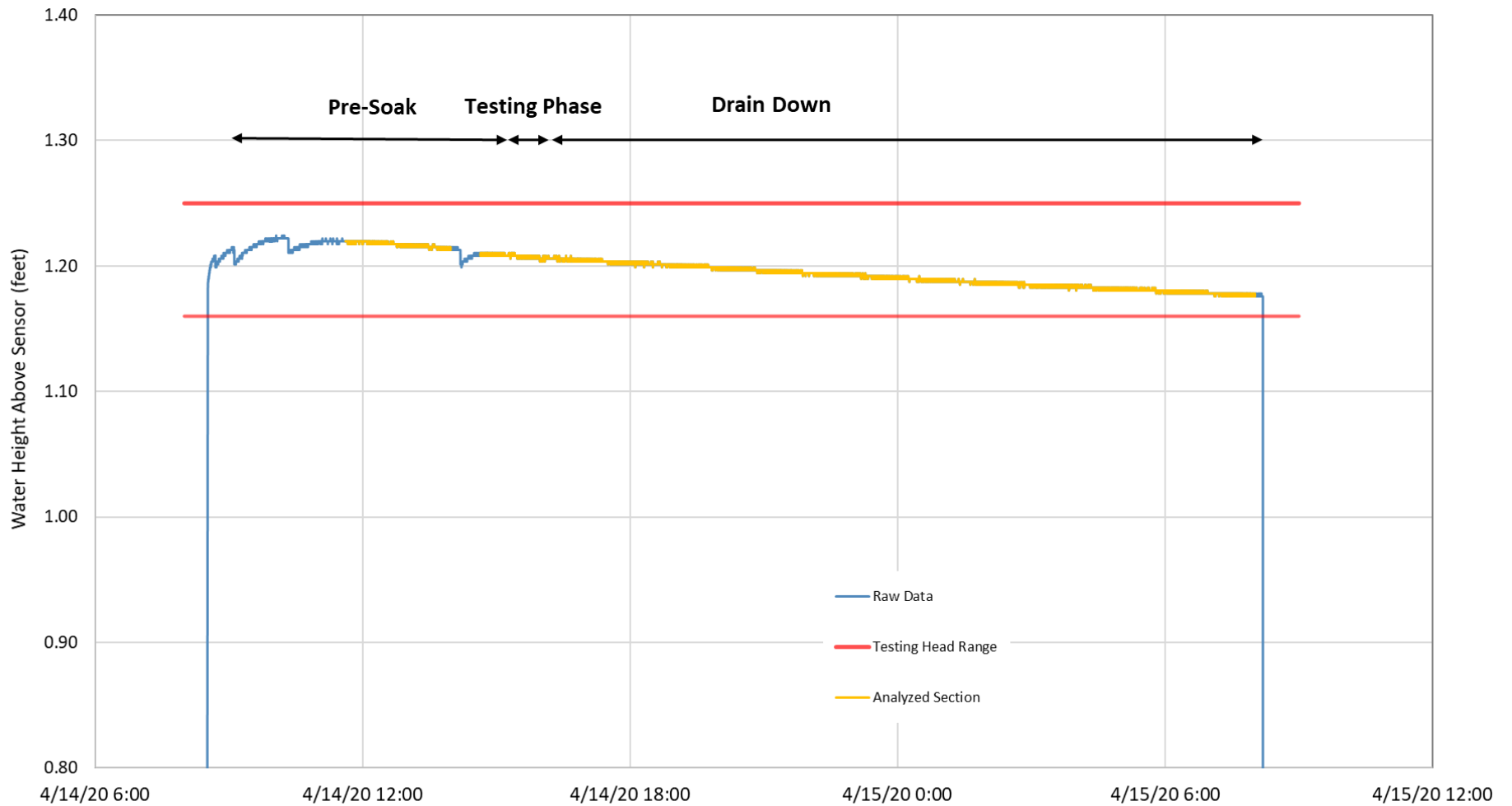

Notes:

1. PIT-2-20 was started on April 14, 2020 and completed on April 15, 2020.
2. After approximately 7 hours the PIT was allowed to drain until the next morning.
3. The testing phase head range was analyzed during the testing period.

PIT-2-20 Hydrograph

Benaroya Co South Hill Business & Technology Center
Puyallup, Washington



Figure 5

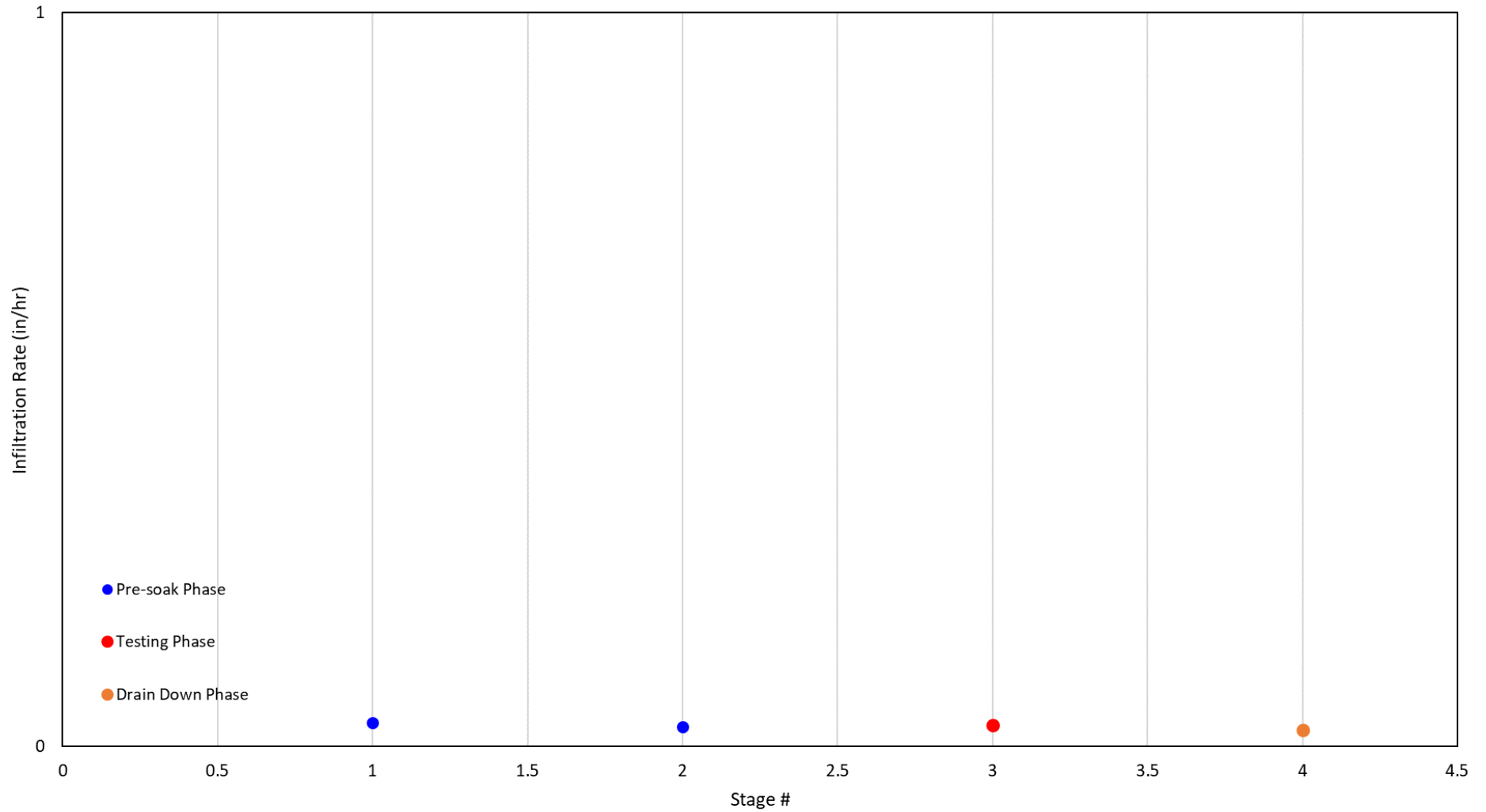

Notes:

1. The pre-soak period is intended to saturate the soil and is not taken to be the long-term infiltration rate.
2. The estimated field measured infiltration rate is 0.03 inches per hour based on the geometric mean of the testing phase.

PIT-2-20 Infiltration Rates

Benaroya Co South Hill Business & Technology Center
Puyallup, Washington



Figure 6

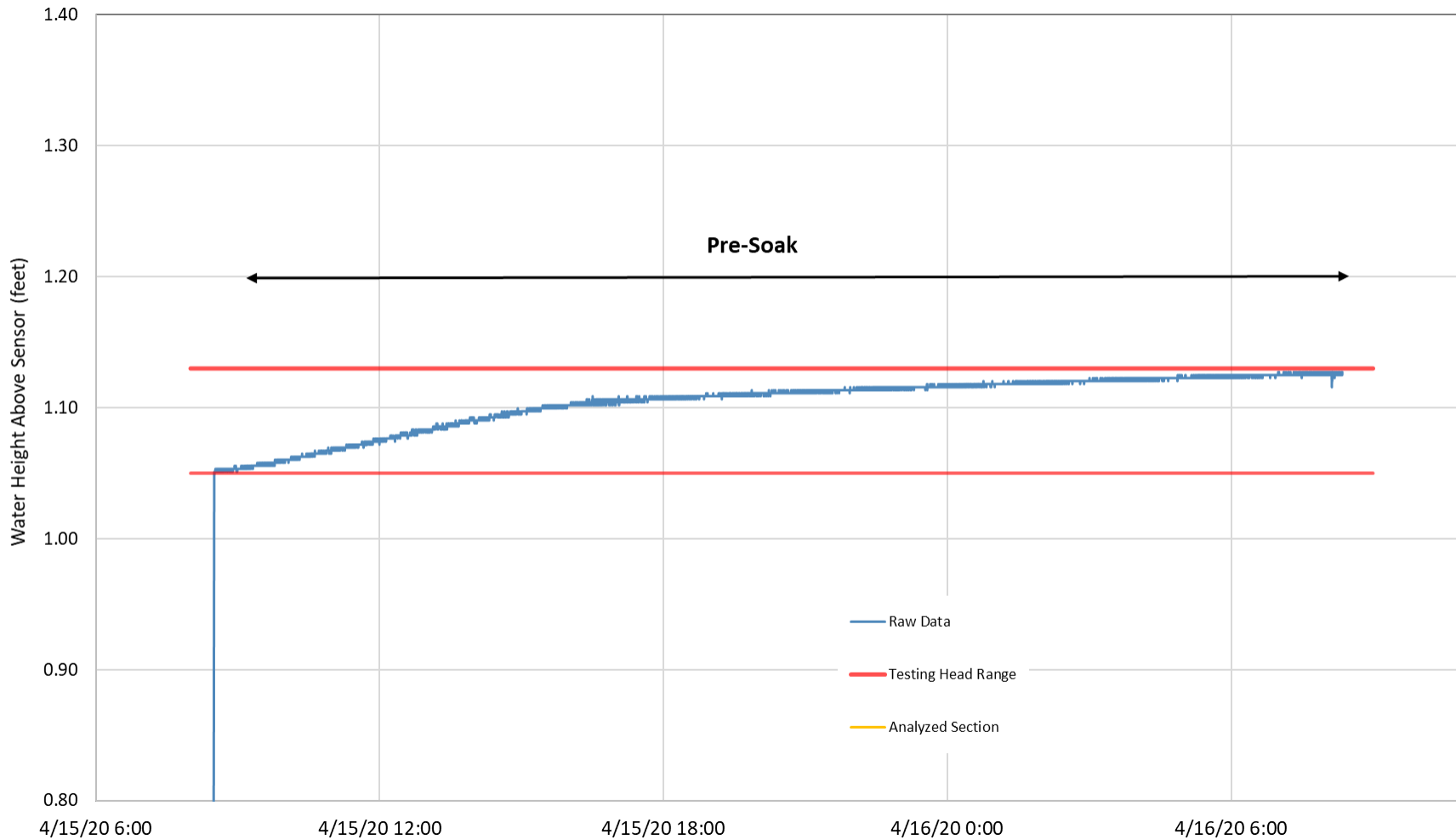

Notes:

1. PIT-3-20 was started on April 15, 2020 and completed on April 16, 2020.
2. After approximately 7 hours the PIT was allowed to drain until the next morning.
3. The water level rose during the duration of the pre-soak, testing and drain down periods, due to high groundwater level near the PIT.

PIT-3-20 Hydrograph

Benaroya Co South Hill Business & Technology Center
Puyallup, Washington



Figure 7

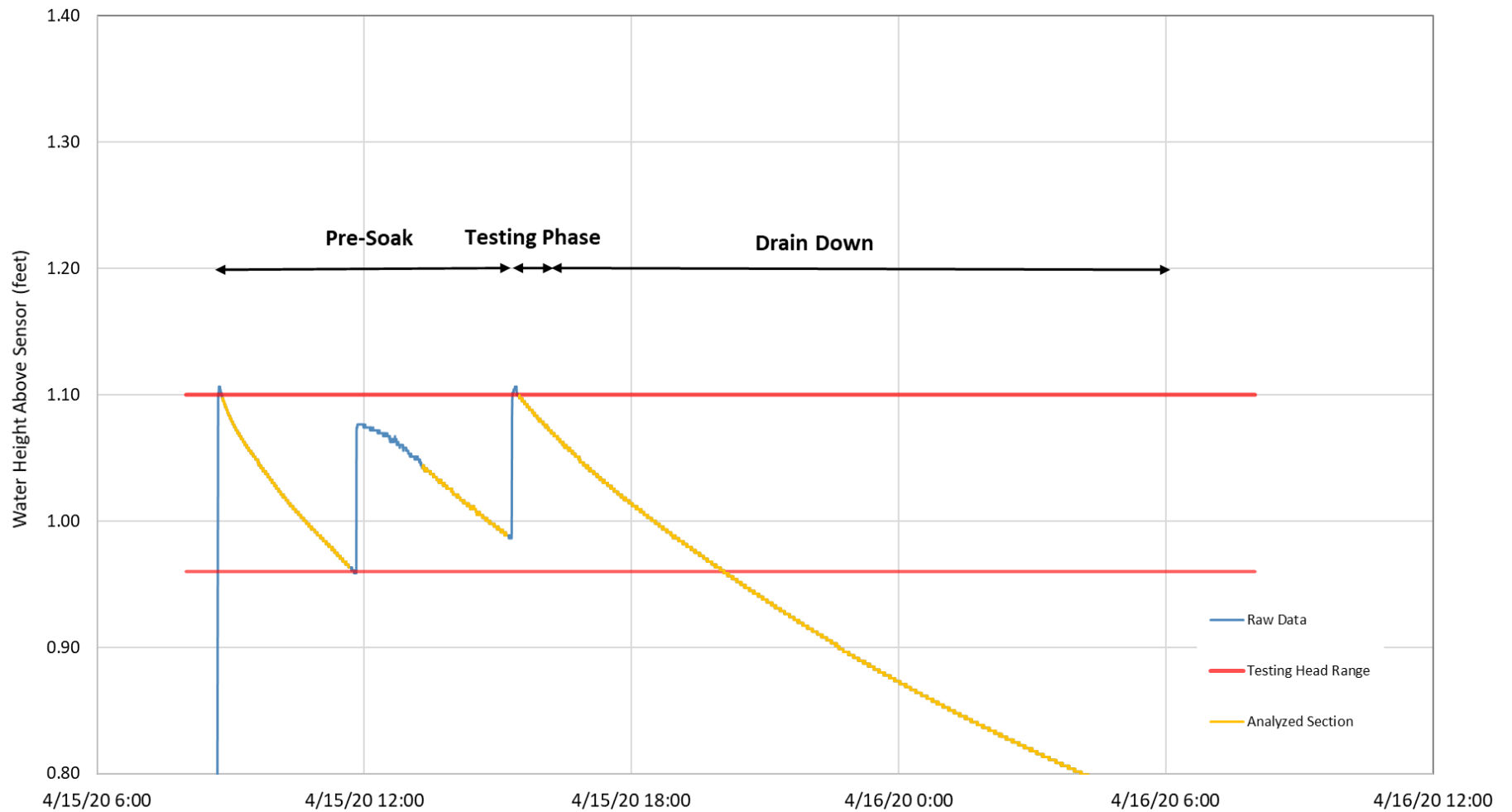

Notes:

1. PIT-4-20 was started on April 15, 2020 and completed on April 16, 2020.
2. After approximately 7 hours the PIT was allowed to drain until the next morning.
3. The testing phase head range was analyzed during the testing period.

PIT-4-20 Hydrograph

Benaroya Co South Hill Business & Technology Center
Puyallup, Washington



Figure 8

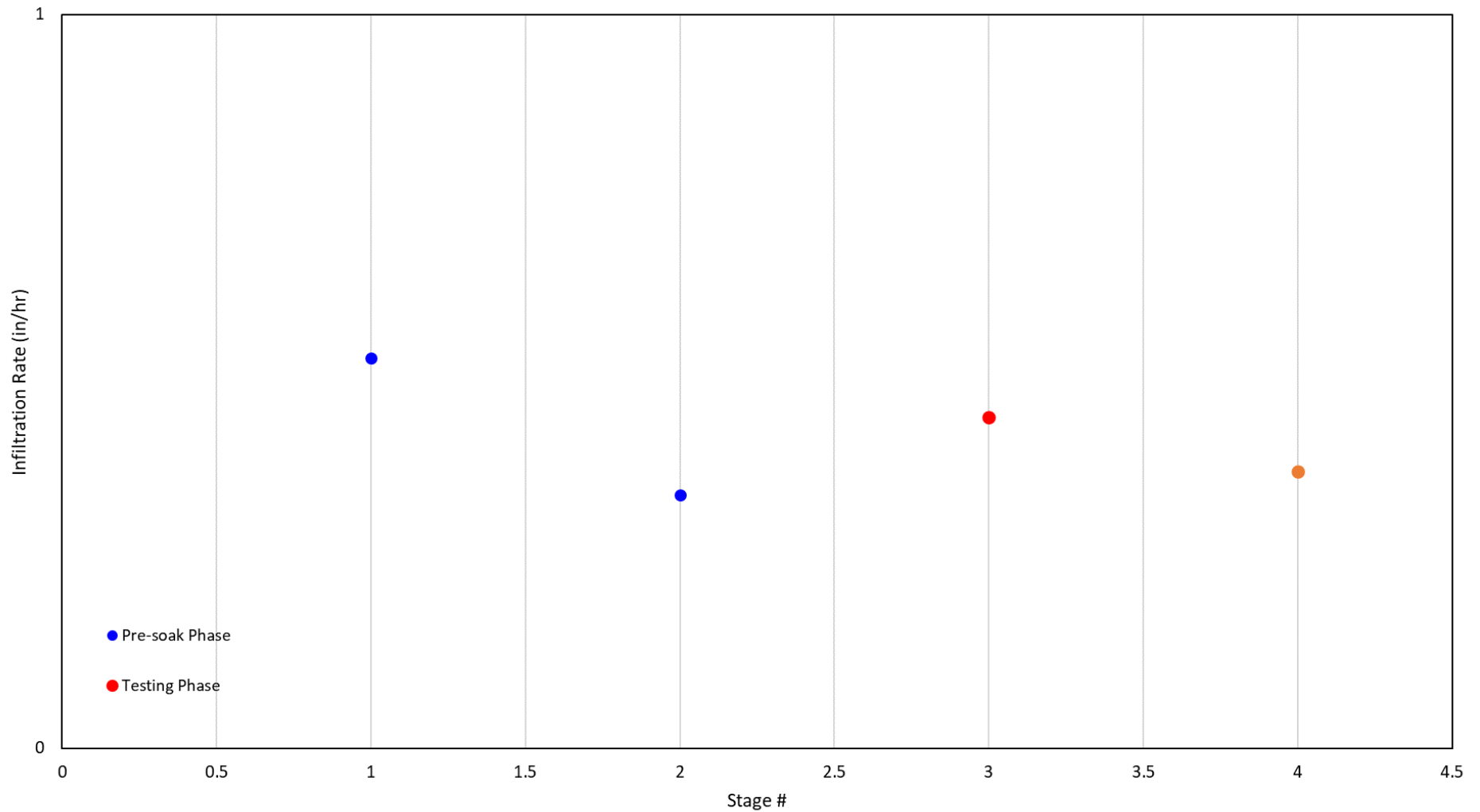

Notes:

1. The pre-soak period is intended to saturate the soil and is not taken to be the long-term infiltration rate.
2. The estimated field measured infiltration rate is 0.45 inches per hour based on the geometric mean of the testing phase.

PIT-4-20 Infiltration Rates

Benaroya Co South Hill Business & Technology Center
Puyallup, Washington



Figure 9

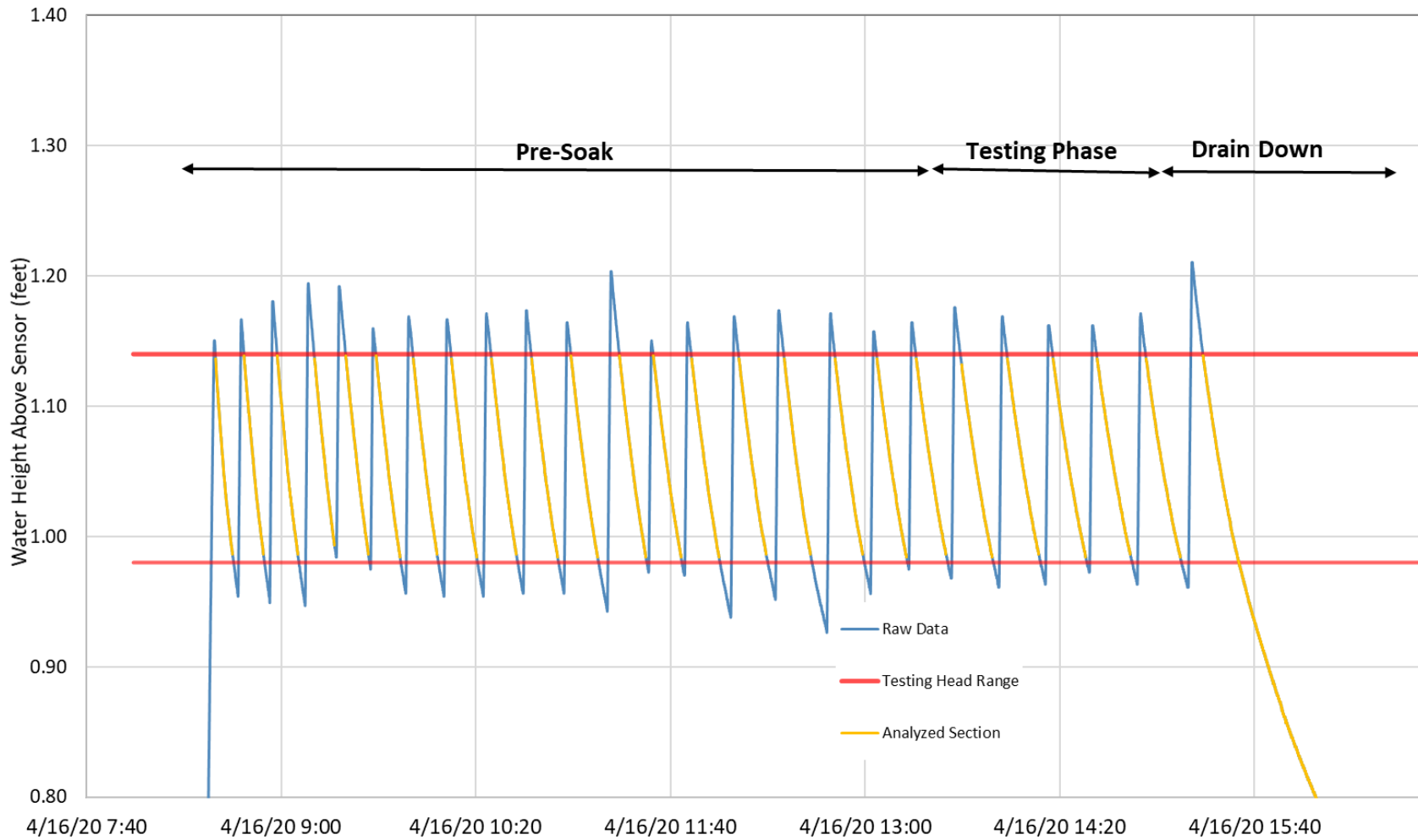

Notes:

1. PIT-5-20 was completed on April 16, 2020.
2. After approximately 7 hours the PIT was allowed to drain completely.
3. The testing phase head range was analyzed during the testing period.

PIT-5-20 Hydrograph

Benaroya Co South Hill Business & Technology Center
Puyallup, Washington



Figure 10

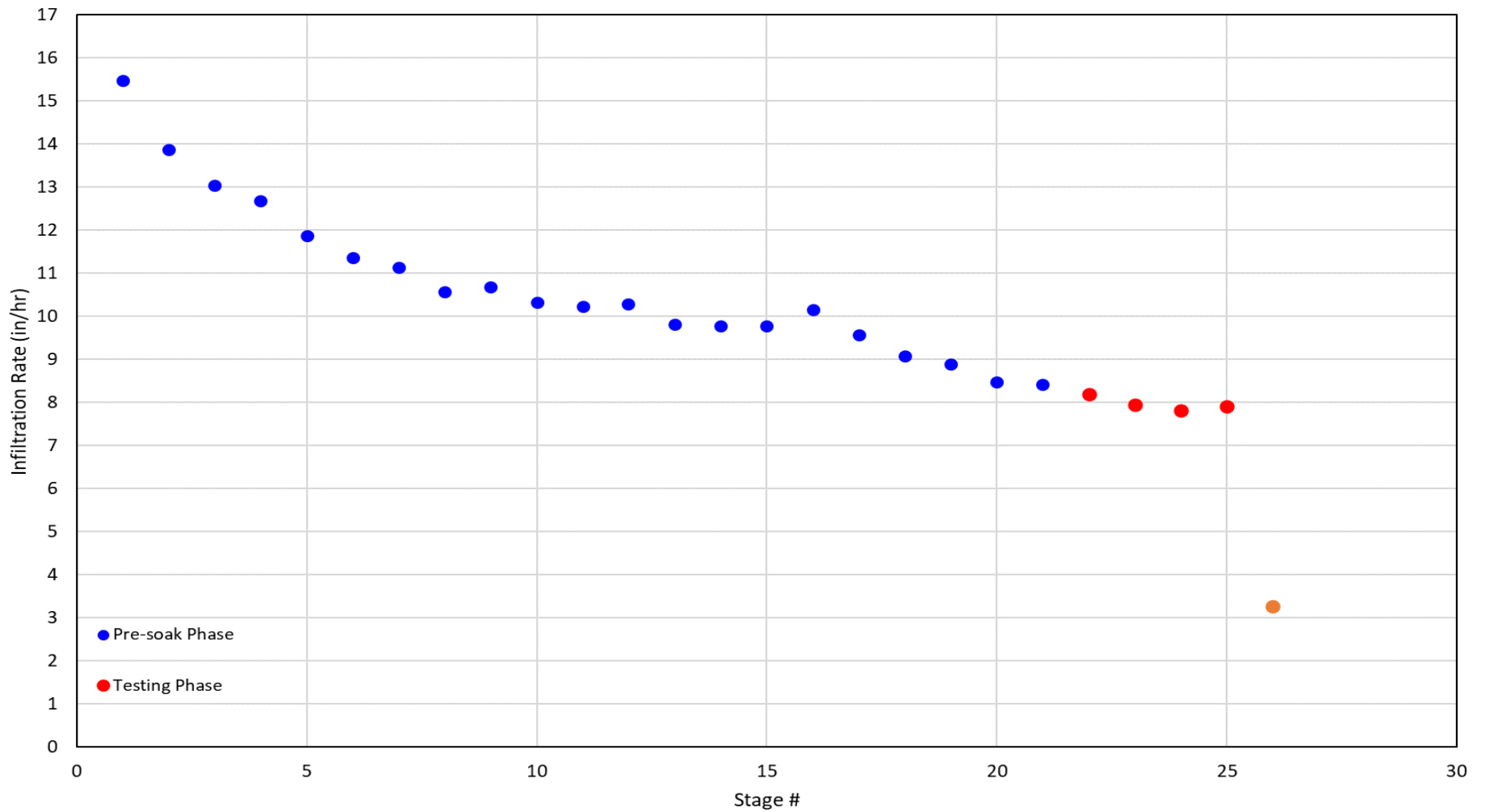

Notes:

1. The pre-soak period is intended to saturate the soil and is not taken to be the long-term infiltration rate.
2. The estimated field measured infiltration rate is 7.97 inches per hour based on the geometric mean of the testing phase.

PIT-5-20 Infiltration Rates

Benaroya Co South Hill Business & Technology Center
Puyallup, Washington



Figure 11

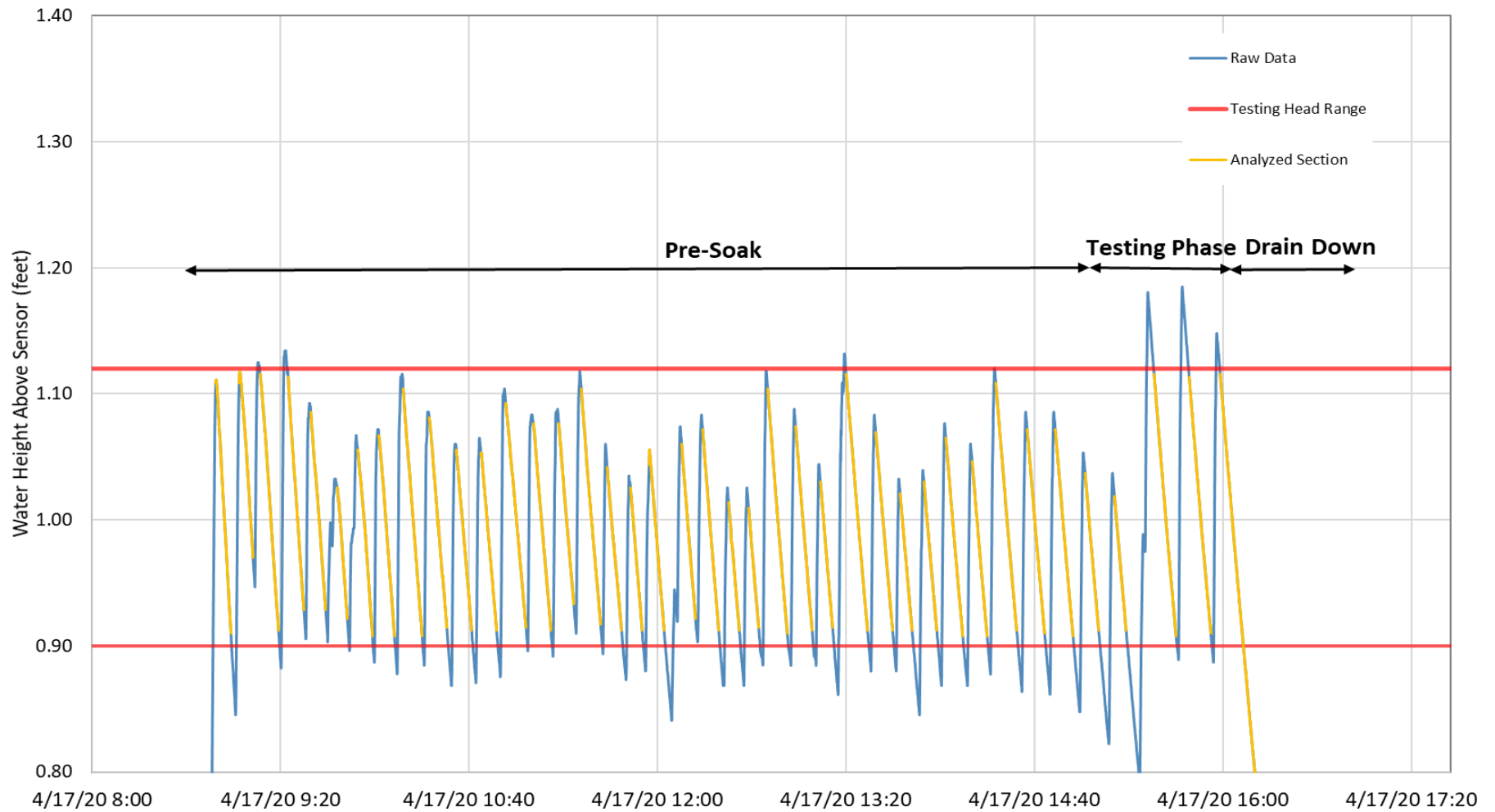

Notes:

1. PIT-6-20 was completed on April 17, 2020.
2. After approximately 7 hours the PIT was allowed to drain completely.
3. The testing phase head range was analyzed during the testing period.

PIT-6-20 Hydrograph

Benaroya Co South Hill Business & Technology Center
Puyallup, Washington



Figure 12

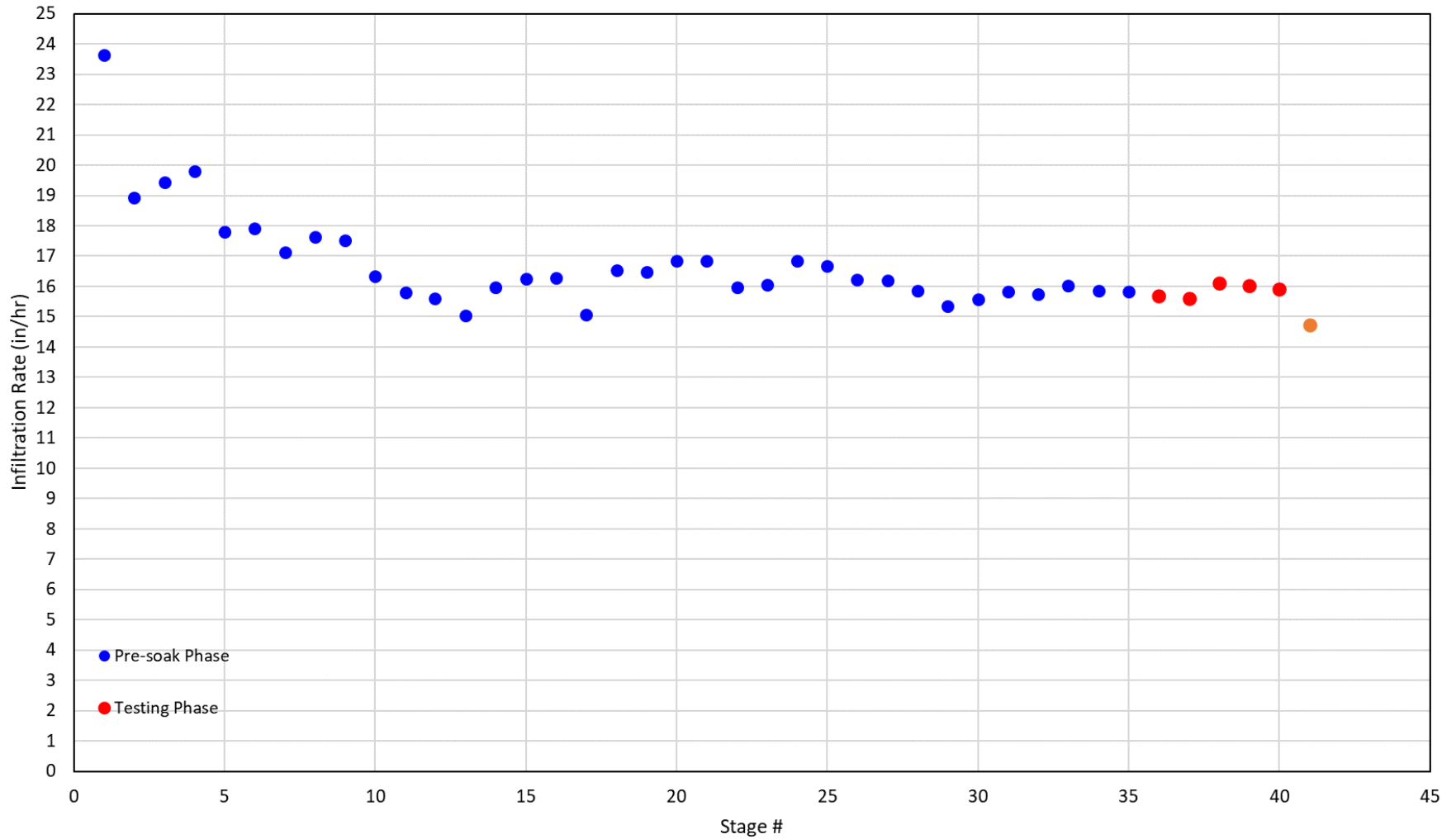

Notes:

1. The pre-soak period is intended to saturate the soil and is not taken to be the long-term infiltration rate.
2. The estimated field measured infiltration rate is 15.86 inches per hour based on the geometric mean of the testing phase.

PIT-6-20 Infiltration Rates

Benaroya Co South Hill Business & Technology Center
Puyallup, Washington



Figure 13

APPENDIX A
Field Explorations

APPENDIX A FIELD EXPLORATIONS

Subsurface soil and groundwater conditions were evaluated by excavating 11 test pits/PITs (TP-1-20 through TP-5-20 and PIT-1-20 through PIT-6-20), and three borings in which two were completed as monitoring wells at the approximate locations shown on Figure 2. The test pits were completed by Kelly's Excavating between April 13 and 17, 2020. The borings/monitoring wells were drilled on July 8, 2020 to monitor groundwater levels during the winter season. In addition, we conducted small-scale pilot infiltration tests (PITs) in test pits PIT-1-20 through PIT-6-20. Locations of the explorations were determined in the field by using a global positioning system (GPS) enabled tablet.

Test Pits

The test pits and PITs were excavated using a Takeuchi TB 138 mini excavator to depths ranging from 7½ to 10 feet below ground surface (bgs). The test pits were continuously observed by a geologist from our firm who examined and classified the soils encountered, obtained representative soil samples and maintained a detailed log of each test pit. Density was estimated from difficulty of digging, difficulty of sample collection using a hand-held trowel and probe rod penetration. In addition, pertinent information including soil sample depths, stratigraphy and groundwater seepage were recorded.

The soils encountered during excavation were visually classified in general accordance with the Unified Soil Classification System (USCS) and ASTM International (ASTM) D 2488 summarized in Figure A-1. The logs of the test pits and PITs are presented in Figures A-2 through A-12. The logs are based on our interpretation of the field and laboratory data and indicate the various soils encountered. They also indicate the approximate depths at which the soils or their characteristics change; although the change may be gradual. If the change occurred between sampling locations, the depth was inferred.

Representative soil samples were obtained from the test pits, logged, sealed in plastic bags and transported to our laboratory. The field classifications were further evaluated in our laboratory.

The test pits were backfilled with the excavated soils and compacted to the extent practical with the bucket of the excavator. The fill was not compacted to the requirements of structural fill.

Monitoring Wells

Hollow-stem auger borings were completed at two locations for the purpose of installing monitoring wells for recording seasonal groundwater fluctuations. The explorations were continuously monitored by geotechnical engineer from our firm who examined and classified the soils encountered, obtained representative soil samples, observed groundwater conditions and prepared a detailed boring log of each exploration. The logs are based on our interpretation of the field and laboratory data and indicate the various types of soils encountered. The logs also indicate the depths at which these soils or their characteristics change, although the change may actually be gradual. If the change occurred between samples, it was interpreted.

Soils encountered in the explorations were visually classified in general accordance with the classification system described above and in Figure A-1. Observations of groundwater conditions were made during

exploration, and these observations represent a short-term condition and may or may not be representative of the long-term groundwater conditions at the site.

Samples from the drilled borings were obtained using a standard penetration test (SPT) sampler driven into the soil with a 140-pound hammer. The number of blows required to drive the sampler the last 12 inches or other indicated distances are recorded on the boring log for the SPT samples. The logs of the borings are presented in Figures A-13 through A-15. The exploration logs are based on our interpretation of the field and laboratory data and indicate the various types of soils encountered. They also indicate the depths at which these soils or their characteristics change; although, the change might actually be gradual.

Observations of groundwater conditions were made during drilling and are included on the boring logs. These observations represent a short-term condition and may or may not be representative of the long-term groundwater conditions at the site. Groundwater conditions observed during drilling should be considered approximate.

Monitoring wells (2-inch-diameter) were installed to allow measurement of groundwater levels following drilling. The wells should be decommissioned by a licensed well driller in accordance with Chapter 173-160 of the Washington Administrative Code (WAC) when they are no longer needed for data collection. Alternatively, the wells could be kept intact for use during project bidding and then be decommissioned under the construction contract.

Pilot Infiltration Testing

Six small-scale PITs were conducted in test pits PIT1-20 through PIT-6-20 within the footprint of the proposed parking lot expansion area. Figure 2 shows the approximate locations of the test pits where the small-scale PITs were performed. The PITs were completed in general accordance with the guidelines provided in the Washington State Department of Ecology Stormwater Management Manual for Western Washington (SMMWW).

Methodology

For all six PITs, a graduated yard stick was driven into the floor of each test pit as a visual reference for monitoring water levels during testing. A piezoelectric pressure transducer was secured to the bottom of the yard stick to provide accurate water level records in 5-second intervals throughout the duration of the tests. Full water-level records recorded for each test are plotted on Figures 3, 5, 7, 8, 10, and 12.

The first phase of a PIT is the “pre-soak” in which the test pit is filled and a water depth of at least 12 inches is maintained for approximately 6 hours. During pre-soak, water is added as necessary to keep the water depth in the test pit between approximately 12 and 14 inches. The pre-soak stage is intended to fully saturate the soil below the test pit. Water must be added more frequently to test pits exhibiting higher rates of infiltration.

The second phase performed was the “testing phase” in which the water depth in the test pit is kept at a depth of 6 to 12 inches, comparable with proposed operational conditions for the planned infiltration facility, for one hour. Infiltration rates are dependent on the water depth in the pit because the hydraulic head of the water column ‘pushes’ water into the ground. For this reason, the testing stage requires a constant, or near-constant water depth. Ideally, water is added to the pit at a rate that would maintain the water depth for a period of one hour with water inflow volume measurements taken every 15 to 30 minutes.

During the testing phase, the water level is allowed to decline over a small, 1- to 2-inch interval. The infiltration rate is calculated by finding the slope of each stage over the same head range, which provides much greater accuracy than attempting to measure inflow volumes.

The third phase performed was the “drain-down” in which the PITs are left undisturbed until the water drains completely. The drain-down period shows how infiltration changes over a continuous range of declining water depths.

The plots of apparent PIT Infiltration rate for successive stages of each test (Figures 4, 6, 9, 11, and 13) provide a visual confirmation of subgrade saturation as infiltration rates decline to asymptotic steady-state values toward the end of the pre-soaking period when the water depth is maintained between 12 to 14 inches. The measured infiltration rates determined during the testing phase are assumed to approximate the saturated (vertical) hydraulic conductivity of the test pit subgrade.

Test Descriptions

Each of the test pits were initially excavated with a backhoe to approximately 4 feet long by 4 feet wide and 4 feet deep with the sidewalls kept as vertical as possible. Water for infiltration was provided by Kelly's Excavating using a 2,400-gallon water truck. PITs were conducted at a depth of 4 feet in each test pit.

- PIT-1-20 was conducted on April 13, 2020. The soil at the initial bottom (test elevation) of PIT-1-20 generally consisted of medium dense, gray-brown silty fine sand with occasional gravel. Groundwater seepage was not observed while excavating. After 6 hours of the pre-soak, the water level had not dropped (no infiltration), and the test was aborted. The transducer was removed, the remaining water was bailed out of the test pit using the bucket of the backhoe. The test pit was over excavated to a depth of 7½ feet. No groundwater seepage was observed after the PIT. The entire transducer record was analyzed and indicated zero infiltration.
- PIT-2-20 was conducted on April 15, 2020. The soil at the initial bottom of the PIT generally consisted of medium dense, gray-brown fine to medium sand with silt and occasional gravel. Groundwater seepage was not observed while excavating. After six hours of the pre-soak, the water level had not dropped (no infiltration) and the test pit was left overnight to drain. On the morning of April 15, 2020, the transducer was removed, the remaining water was bailed out of the test pit using the bucket of the backhoe, and the test pit was over excavated to a depth of 9 feet bgs. No groundwater seepage was observed after the PIT. The entire transducer record was analyzed and indicated zero infiltration.
- PIT-3-20 was excavated on April 14, 2020 and covered with plywood for testing the following day. The soil at the initial bottom of the PIT generally consisted of medium dense, blue-gray silty fine sand. Slight groundwater seepage was observed at a depth of 2 feet bgs while excavating. On the morning of April 15, 2020, prior to starting the PIT, there was approximately 3 inches of standing water in the bottom of the pit. After six hours of the pre-soak, the water level had not dropped (no infiltration) and the test pit was left overnight to drain. On the morning of April 16, 2020, the water level in the pit was higher than the night before, indicating groundwater seepage into the PIT, resulting in a negative infiltration rate. The transducer was removed, the remaining water was bailed out of the test pit using the bucket of the backhoe, and the test pit was overexcavated to a depth of 7½ feet bgs. PIT-3-20 was determined to have an effective infiltration rate of 0 inches per hour.
- PIT-4-20 was excavated on April 14, 2020 and covered with plywood for testing the following day. The soil at the initial bottom of the PIT generally consisted of fine sand with silt. Slight groundwater seepage

was observed at a depth of 3¾ feet bgs while excavating. On the morning of April 15, 2020, prior to starting the PIT, there was approximately 6 inches of standing water in the bottom of the pit. The pre-soak required two refills during approximately 6 hours to maintain a water depth of at least 12 inches. The testing phase had 1 stage that was analyzed (Figure 8). The testing phase head-change stage was calculated to determine a measured infiltration rate ($K_{sat\ initial}$) of 0.5 inches per hour in PIT-4-20 (Figure 9). After approximately 7 hours of testing, the test pit was allowed to drain for an additional hour. After infiltration testing was completed, the test pit was overexcavated to a depth of 10 feet bgs. Groundwater seepage was not observed after the PIT.

- PIT-5-20 was conducted on April 15, 2020. The soil at the initial bottom of the PIT generally consisted of medium dense, tan-brown silty fine sand with gravel. Groundwater seepage was not observed while excavating. The pre-soak required 18 refills during approximately 6 hours to maintain a water depth of at least 12 inches. The testing phase had five stages that were analyzed (Figure 10). The geometric mean of the testing phase head-change stages was calculated to determine a measured infiltration rate ($K_{sat\ initial}$) of 8.0 inches per hour in PIT-5-20 (Figure 11). After approximately 7 hours of testing, the test pit was allowed to drain completely. After infiltration testing was completed, the test pit was over-excavated to a depth of 10 feet bgs. Groundwater seepage was not observed after the PIT.
- PIT-6-20 was conducted on April 17, 2020. The soil at the bottom of the PIT generally consisted of medium dense, brown fine to coarse gravel. Groundwater seepage was not observed while excavating. The pre-soak required 35 refills during approximately 6 hours to maintain a water depth of at least 12 inches. The testing phase had four stages that were analyzed (Figure 12). The geometric mean of the testing phase head-change stages was calculated to determine a measured infiltration rate ($K_{sat\ initial}$) of 15.9 inches per hour in PIT-6-20 (Figure 13). After approximately 7 hours of testing, the test pit was allowed to drain completely. After infiltration the test pit was overexcavated to a depth of 8 feet bgs. Moderate groundwater seepage was observed at 6 feet bgs.

Design Infiltration Rates

Three correction factors are applied to $K_{sat\ initial}$ to calculate the design saturated hydraulic conductivity ($K_{sat\ design}$) as required by the SMMWW. The correction factors consider the site variability and number of locations tested (CF_v), the testing method (CF_t), and the degree of influent control to prevent siltation and bio buildup (CF_m). CF_t accounts for uncertainties in the testing methods and is equal to 0.5 for small-scale PITs. CF_m accounts for the clogging effect of suspended material in stormwater which will cause the soil's initial infiltration rate to gradually decline. The maintenance schedule calls for removing sediment when the BMP is infiltrating at only 90 percent of its design capacity, so CF_m is equal to 0.9. CF_v can vary between 0.33 to 1.0 based on the variability of the soils on the site. CF_v was set to 0.8 for the three PITs located in the undeveloped area of the site (PIT-4-20 to PIT-6-20 in Table A-1 below).

The design saturated hydraulic conductivity is calculated by:

$$K_{sat\ design} = K_{sat\ initial} \times CF_v \times CF_t \times CF_m$$

All correction factors and hydraulic conductivities are shown in Table A-1.

TABLE A-1. INFILTRATION RATES FROM PILOT INFILTRATION TESTING

PIT	K_{sat} initial (inches per hour)	CF_v¹	CF_t²	CF_m³	K_{sat} design (inches per hour)
PIT-1-20	0	-	-	-	0
PIT-2-20	0	-	-	-	0
PIT-3-20	NA	-	-	-	NA ⁴
PIT-4-20	0.5	0.8	0.5	0.9	0.2
PIT-5-20	8.0	0.8	0.5	0.9	2.9
PIT-6-20	15.9	0.8	0.5	0.9	5.7

Notes:

¹ Site variability and number of locations tested. CF_v = 0.33 to 1.0

² Test method. CF_t = 0.5 for small-scale PITs

³ Degree of influent control to prevent siltation and bio-buildup. CF_m = 0.9

⁴ NA, PIT-3-20 could not be analyzed due to groundwater seepage entering the test pit excavation during testing

SOIL CLASSIFICATION CHART

MAJOR DIVISIONS			SYMBOLS		TYPICAL DESCRIPTIONS
			GRAPH	LETTER	
COARSE GRAINED SOILS	GRAVEL AND GRAVELLY SOILS	CLEAN GRAVELS <small>(LITTLE OR NO FINES)</small>		GW	WELL-GRADED GRAVELS, GRAVEL - SAND MIXTURES
		GRAVELS WITH FINES <small>(APPRECIABLE AMOUNT OF FINES)</small>		GP	POORLY-GRADED GRAVELS, GRAVEL - SAND MIXTURES
		GRAVELS WITH FINES <small>(APPRECIABLE AMOUNT OF FINES)</small>		GM	SILTY GRAVELS, GRAVEL - SAND - SILT MIXTURES
	SAND AND SANDY SOILS	CLEAN SANDS <small>(LITTLE OR NO FINES)</small>		SW	WELL-GRADED SANDS, GRAVELLY SANDS
		SANDS WITH FINES <small>(APPRECIABLE AMOUNT OF FINES)</small>		SP	POORLY-GRADED SANDS, GRAVELLY SAND
		SANDS WITH FINES <small>(APPRECIABLE AMOUNT OF FINES)</small>		SM	SILTY SANDS, SAND - SILT MIXTURES
FINE GRAINED SOILS	SILTS AND CLAYS	LIQUID LIMIT LESS THAN 50		ML	INORGANIC SILTS, ROCK FLOUR, CLAYEY SILTS WITH SLIGHT PLASTICITY
		LIQUID LIMIT LESS THAN 50		CL	INORGANIC CLAYS OF LOW TO MEDIUM PLASTICITY, GRAVELLY CLAYS, SANDY CLAYS, SILTY CLAYS, LEAN CLAYS
		LIQUID LIMIT LESS THAN 50		OL	ORGANIC SILTS AND ORGANIC SILTY CLAYS OF LOW PLASTICITY
	SILTS AND CLAYS	LIQUID LIMIT GREATER THAN 50		MH	INORGANIC SILTS, MICACEOUS OR DIATOMACEOUS SILTY SOILS
		LIQUID LIMIT GREATER THAN 50		CH	INORGANIC CLAYS OF HIGH PLASTICITY
		LIQUID LIMIT GREATER THAN 50		OH	ORGANIC CLAYS AND SILTS OF MEDIUM TO HIGH PLASTICITY
HIGHLY ORGANIC SOILS			PT	PEAT, HUMUS, SWAMP SOILS WITH HIGH ORGANIC CONTENTS	

NOTE: Multiple symbols are used to indicate borderline or dual soil classifications

Sampler Symbol Descriptions

	2.4-inch I.D. split barrel
	Standard Penetration Test (SPT)
	Shelby tube
	Piston
	Direct-Push
	Bulk or grab
	Continuous Coring

Blowcount is recorded for driven samplers as the number of blows required to advance sampler 12 inches (or distance noted). See exploration log for hammer weight and drop.

"P" indicates sampler pushed using the weight of the drill rig.

"WOH" indicates sampler pushed using the weight of the hammer.

NOTE: The reader must refer to the discussion in the report text and the logs of explorations for a proper understanding of subsurface conditions. Descriptions on the logs apply only at the specific exploration locations and at the time the explorations were made; they are not warranted to be representative of subsurface conditions at other locations or times.

ADDITIONAL MATERIAL SYMBOLS

SYMBOLS		TYPICAL DESCRIPTIONS
GRAPH	LETTER	
	AC	Asphalt Concrete
	CC	Cement Concrete
	CR	Crushed Rock/Quarry Spalls
	SOD	Sod/Forest Duff
	TS	Topsoil

Groundwater Contact



Measured groundwater level in exploration, well, or piezometer



Measured free product in well or piezometer

Graphic Log Contact

Distinct contact between soil strata

Approximate contact between soil strata

Material Description Contact

Contact between geologic units

Contact between soil of the same geologic unit

Laboratory / Field Tests

%F	Percent fines
%G	Percent gravel
AL	Atterberg limits
CA	Chemical analysis
CP	Laboratory compaction test
CS	Consolidation test
DD	Dry density
DS	Direct shear
HA	Hydrometer analysis
MC	Moisture content
MD	Moisture content and dry density
Mohs	Mohs hardness scale
OC	Organic content
PM	Permeability or hydraulic conductivity
PI	Plasticity index
PL	Point load test
PP	Pocket penetrometer
SA	Sieve analysis
TX	Triaxial compression
UC	Unconfined compression
VS	Vane shear

Sheen Classification

NS	No Visible Sheen
SS	Slight Sheen
MS	Moderate Sheen
HS	Heavy Sheen

Key to Exploration Logs



Figure A-1

Date Excavated	4/15/2020	Total Depth (ft)	10	Logged By	WCW	Excavator	Kelly's Excavating, Inc.	Groundwater not observed
				Checked By	DCO	Equipment	Takeuchi TB 138	Caving not observed
Surface Elevation (ft) Vertical Datum	530 NAVD88		Easting (X) Northing (Y)	1198213 671135		Coordinate System Horizontal Datum	WA State Plane South NAD83 (feet)	

Elevation (feet)	Depth (feet)	SAMPLE		Graphic Log	Group Classification	MATERIAL DESCRIPTION	Moisture Content (%)	Fines Content (%)	REMARKS
		Testing Sample	Sample Name Testing						
529	1		1 MC		Duff SM	1 inch forest duff Tan-brown silty fine to medium sand with occasional gravel (medium dense, moist)	14		
528	2				SP-SM	Tan-brown fine sand with silt (medium dense, moist)			
527	3		2						
526	4								
525	5		g _w				11	8	
524	6								
523	7		4		SP	Gray-brown fine sand (dense, moist)			
522	8								
521	9		5/8"				18	5	
520	10								

Date: 2/5/21 Path: \\GEOENGINEERS.COM\WAN\PROJECTS\4\4565064\GINT\456506406.GPJ DBL\Library\Library\GEOENGINEERS_DF_STD_US_JUNE_2017.GLB\GERB_TESTPIT_IP_GEOTEC_%F

Notes: See Figure A-1 for explanation of symbols.
 The depths on the test pit logs are based on an average of measurements across the test pit and should be considered accurate to 1/2 foot.
 Coordinates Data Source: Horizontal approximated based on Aerial Imagery. Vertical approximated based on Google Earth.

Log of Test Pit TP-1-20



Project: Benaroya Co South Hill Business & Technology Center
 Project Location: Puyallup, Washington
 Project Number: 4565-064-06

Date Excavated	4/13/2020	Total Depth (ft)	10	Logged By	WCW	Excavator	Kelly's Excavating, Inc.	Groundwater not observed
				Checked By	DCO	Equipment	Takeuchi TB 138	Caving not observed
Surface Elevation (ft) Vertical Datum	540 NAVD88		Easting (X) Northing (Y)	1198187 670919		Coordinate System Horizontal Datum	WA State Plane South NAD83 (feet)	

Elevation (feet)	Depth (feet)	SAMPLE		Graphic Log	Group Classification	MATERIAL DESCRIPTION	Moisture Content (%)	Fines Content (%)	REMARKS
		Testing Sample	Sample Name Testing						
539	1		1 MC		Duff	2 inches forest duff	11		
538	2				SM	Brown silty fine sand with occasional gravel and trace organic matter (roots) (loose to medium dense, moist)			
537	3		2		SP-SM	Brown fine to medium sand with silt (loose to medium dense, moist)			
536	4								
535	5		g _w		SM	Tan-brown silty fine to medium sand (medium dense, moist)	16	13	
534	6								
533	7		4						
532	8								
531	9								
530	10		5						

Notes: See Figure A-1 for explanation of symbols.
The depths on the test pit logs are based on an average of measurements across the test pit and should be considered accurate to 1/2 foot.
Coordinates Data Source: Horizontal approximated based on Aerial Imagery. Vertical approximated based on Google Earth.

Log of Test Pit TP-2-20



Project: Benaroya Co South Hill Business & Technology Center
Project Location: Puyallup, Washington
Project Number: 4565-064-06

Figure A-3
Sheet 1 of 1

Date: 2/5/21 Path: \\GEOENGINEERS.COM\WAN\PROJECTS\4565\064\GINT\4565064.GPJ DBL\Library\Library\GEOENGINEERS_DF_STD_US_JUNE_2017.GLB\GER_TESTPIT_IP_GEODEC_%F

Date Excavated	4/13/2020	Total Depth (ft)	10	Logged By	WCW	Excavator	Kelly's Excavating, Inc.	Groundwater not observed
				Checked By	DCO	Equipment	Takeuchi TB 138	Caving not observed
Surface Elevation (ft) Vertical Datum	530 NAVD88		Easting (X) Northing (Y)	1198077 670873		Coordinate System Horizontal Datum	WA State Plane South NAD83 (feet)	

Elevation (feet)	Depth (feet)	SAMPLE		Graphic Log	Group Classification	MATERIAL DESCRIPTION	Moisture Content (%)	Fines Content (%)	REMARKS
		Testing Sample	Sample Name Testing						
					Duff	3 inches forest duff			
529	1		1 MC		SM	Red-brown silty fine to medium sand with occasional gravel and trace organic matter (roots) (loose to medium dense, moist)	16		
528	2								
527	3		2			Becomes brown			
526	4				SM	Gray-brown silty fine to medium sand with gravel (medium dense, moist)			
525	5		g _w				9	13	
524	6								
523	7		4			Grades with less gravel			
522	8								
521	9				SP-SM	Gray-brown fine sand with silt (medium dense, moist)			
520	10		5						

Notes: See Figure A-1 for explanation of symbols.
The depths on the test pit logs are based on an average of measurements across the test pit and should be considered accurate to 1/2 foot.
Coordinates Data Source: Horizontal approximated based on Aerial Imagery. Vertical approximated based on Google Earth.

Log of Test Pit TP-3-20



Project: Benaroya Co South Hill Business & Technology Center
Project Location: Puyallup, Washington
Project Number: 4565-064-06

Figure A-4
Sheet 1 of 1

Date: 2/5/21 Path: \\GEOENGINEERS.COM\WAN\PROJECTS\4565064\GINT\4565064\GINT\4565064\GIB\GERB_TESTPIT_3P_GEOTEC_%F

Date Excavated	4/13/2020	Total Depth (ft)	9.5	Logged By	WCW	Excavator	Kelly's Excavating, Inc.	See "Remarks" section for groundwater observed Caving not observed
Checked By	DCO	Equipment	Takeuchi TB 138					
Surface Elevation (ft) Vertical Datum	530 NAVD88	Easting (X) Northing (Y)	1198229 670635	Coordinate System Horizontal Datum	WA State Plane South NAD83 (feet)			

Elevation (feet)	Depth (feet)	SAMPLE		Graphic Log	Group Classification	MATERIAL DESCRIPTION	Moisture Content (%)	Fines Content (%)	REMARKS
		Testing Sample	Sample Name Testing						
					Duff	3 inches forest duff			
529	1		1 MC		SM	Red-brown silty fine sand with occasional gravel and trace organic matter (roots) (loose to medium dense, moist)	22		
528	2				SM	Red-brown silty fine sand (loose to medium dense, moist)			
527	3		2						
526	4				SM	Brown silty fine sand (medium dense, moist to wet)			
525	5		3						
524	6				SM	Gray silty fine to medium sand with occasional gravel (medium dense, moist)			Slight groundwater seepage observed at 6 feet
523	7		4						
522	8								
521	9		5						

Notes: See Figure A-1 for explanation of symbols.
The depths on the test pit logs are based on an average of measurements across the test pit and should be considered accurate to 1/2 foot.
Coordinates Data Source: Horizontal approximated based on Aerial Imagery. Vertical approximated based on Google Earth.

Log of Test Pit TP-4-20



Project: Benaroya Co South Hill Business & Technology Center
Project Location: Puyallup, Washington
Project Number: 4565-064-06

Date: 2/5/21 Path: \\GEOENGINEERS.COM\WAN\PROJECTS\4565064\GINT\4565064\GINT\4565064\GIB_TESTPIT_4P_GEOTEC_%F

Date Excavated	4/13/2020	Total Depth (ft)	9.5	Logged By	WCW	Excavator	Kelly's Excavating, Inc.	See "Remarks" section for groundwater observed Caving not observed
Checked By	DCO	Equipment	Takeuchi TB 138					
Surface Elevation (ft) Vertical Datum	520 NAVD88	Easting (X) Northing (Y)	1198088 670543	Coordinate System Horizontal Datum	WA State Plane South NAD83 (feet)			

Elevation (feet)	Depth (feet)	SAMPLE		Graphic Log	Group Classification	MATERIAL DESCRIPTION	Moisture Content (%)	Fines Content (%)	REMARKS
		Testing Sample	Sample Name Testing						
519	1		1 MC		Duff	4 inches forest duff			
518	2				SM	Red-brown silty fine sand (loose to medium dense, moist)	10		
517	3		2		SP-SM	Tan fine sand with silt (loose to medium dense, moist)			
516	4				SM	Brown silty fine to coarse sand with gravel (medium dense, moist)	15	36	
515	5		g _w		SM	Brown silty fine to coarse sand with gravel (medium dense, moist)			
514	6				GM	Brown silty fine to coarse gravel with sand (medium dense, moist)	13	33	
513	7		g _w		SM	Brown silty fine to coarse sand (medium dense, moist)			
512	8				SM	Brown silty fine to coarse sand (medium dense, moist)			
511	9		5		SM	Brown silty fine to coarse sand (medium dense, moist)			Slight groundwater seepage observed at approximately 8½ feet

Notes: See Figure A-1 for explanation of symbols.
The depths on the test pit logs are based on an average of measurements across the test pit and should be considered accurate to ½ foot.
Coordinates Data Source: Horizontal approximated based on Aerial Imagery. Vertical approximated based on Google Earth.

Log of Test Pit TP-5-20



Project: Benaroya Co South Hill Business & Technology Center
Project Location: Puyallup, Washington
Project Number: 4565-064-06

Figure A-6
Sheet 1 of 1

Date: 2/5/21 Path: \\GEOENGINEERS.COM\WAN\PROJECTS\4565064\GINT\4565064\GINT\4565064\GIB\GERB_TESTPIT_5P_GEOTEC_5.F

Date Excavated	4/13/2020	Total Depth (ft)	7.5	Logged By	WCW	Excavator	Kelly's Excavating, Inc.	Groundwater not observed
				Checked By	DCO	Equipment	Takeuchi TB 138	Caving not observed
Surface Elevation (ft) Vertical Datum	490 NAVD88	Easting (X) Northing (Y)	1197914 670658	Coordinate System Horizontal Datum	WA State Plane South NAD83 (feet)			

Elevation (feet)	Depth (feet)	SAMPLE		Graphic Log	Group Classification	MATERIAL DESCRIPTION	Moisture Content (%)	Fines Content (%)	REMARKS
		Testing Sample	Sample Name Testing						
439	1		1 MC		SM	Brown silty fine to medium sand (medium dense, moist)	10		
438	2		2		SM	Gray and brown silty fine sand with occasional gravel (medium dense, moist)			
437	3								
436	4		2 w		SM	Gray-brown silty fine sand with gravel (medium dense, moist)	15	44	
435	5		4						
434	6								
433	7		5						

Date: 2/5/21 Path: \\GEOENGINEERS.COM\WAN\PROJECTS\4565064\GINT\4565064\GIB\GERB_TESTPIT_1P_GEOTEC_%F

Notes: See Figure A-1 for explanation of symbols.
The depths on the test pit logs are based on an average of measurements across the test pit and should be considered accurate to 1/2 foot.
Coordinates Data Source: Horizontal approximated based on Aerial Imagery. Vertical approximated based on Google Earth.

Log of Test Pit PIT-1-20



Project: Benaroya Co South Hill Business & Technology Center
Project Location: Puyallup, Washington
Project Number: 4565-064-06

Date Excavated	4/15/2020	Total Depth (ft)	9	Logged By	WCW	Excavator	Kelly's Excavating, Inc.	Groundwater not observed
				Checked By	DCO	Equipment	Takeuchi TB 138	Caving not observed
Surface Elevation (ft) Vertical Datum	490 NAVD88	Easting (X) Northing (Y)	1197906 670815	Coordinate System Horizontal Datum	WA State Plane South NAD83 (feet)			

Elevation (feet)	Depth (feet)	SAMPLE		Graphic Log	Group Classification	MATERIAL DESCRIPTION	Moisture Content (%)	Fines Content (%)	REMARKS
		Testing Sample	Sample Name Testing						
439	1		1 MC		SM	Gray-brown silty fine to coarse sand with gravel (medium dense, moist)	8		
438	2				SP-SM	Gray-brown fine to medium sand with silt and occasional gravel (medium dense, moist)			
437	3		2						
436	4		3						
435	5		5/4		GP-GM	Gray-brown fine to coarse gravel with silt and sand (medium dense, moist)	8	7	
434	6				SM	Gray silty sand (medium dense, moist)			
433	7		6		SM	Gray-brown silty fine to coarse sand with gravel (dense, moist)			
432	8								
431	9		7						

Notes: See Figure A-1 for explanation of symbols.
The depths on the test pit logs are based on an average of measurements across the test pit and should be considered accurate to 1/2 foot.
Coordinates Data Source: Horizontal approximated based on Aerial Imagery. Vertical approximated based on Google Earth.

Log of Test Pit PIT-2-20



Project: Benaroya Co South Hill Business & Technology Center
Project Location: Puyallup, Washington
Project Number: 4565-064-06

Date: 2/5/21 Path: \\GEOENGINEERS.COM\WAN\PROJECTS\4565064\GINT\456506406.GPJ DBL\brary\Library\GEOENGINEERS_DF_STD_US_JUNE_2017.GLB\GER_TESTPIT_IP_GEOTEC.3\F

Date Excavated	4/14/2020	Total Depth (ft)	7.5	Logged By	WCW	Excavator	Kelly's Excavating, Inc.	See "Remarks" section for groundwater observed Caving not observed
Checked By	DCO	Equipment	Takeuchi TB 138					
Surface Elevation (ft) Vertical Datum	490 NAVD88	Easting (X) Northing (Y)	1197913 670972	Coordinate System Horizontal Datum	WA State Plane South NAD83 (feet)			

Elevation (feet)	Depth (feet)	SAMPLE		Graphic Log	Group Classification	MATERIAL DESCRIPTION	Moisture Content (%)	Fines Content (%)	REMARKS
		Testing Sample	Sample Name Testing						
439	1		1 MC		SM	Brown silty fine to coarse sand with gravel and cobbles (medium dense, moist)	15		Light groundwater seepage observed at 2 feet
438	2								
437	3				SM	Blue-gray silty fine sand (medium dense, moist)			
436	4		2						
435	5								
434	6		3 MC		SM	Gray-brown silty fine to medium sand with gravel and cobbles (dense, moist)	14	26	
433	7		4		SM	Blue-gray silty fine sand with occasional gravel (very dense, moist)			

Notes: See Figure A-1 for explanation of symbols.
The depths on the test pit logs are based on an average of measurements across the test pit and should be considered accurate to 1/2 foot.
Coordinates Data Source: Horizontal approximated based on Aerial Imagery. Vertical approximated based on Google Earth.

Log of Test Pit PIT-3-20



Project: Benaroya Co South Hill Business & Technology Center
Project Location: Puyallup, Washington
Project Number: 4565-064-06

Figure A-9
Sheet 1 of 1

Date: 2/5/21 Path: \\GEOENGINEERS.COM\WAN\PROJECTS\4565\064\GINT\4565064.GPJ DBL\brary\Library\GEOENGINEERS_DF_STD_US_JUNE_2017.GLB\GER_TESTPIT_IP_GEODEC_%F

Date Excavated	4/14/2020	Total Depth (ft)	10	Logged By	WCW	Excavator	Kelly's Excavating, Inc.	See "Remarks" section for groundwater observed	
				Checked By	DCO	Equipment	Takeuchi TB 138	See "Remarks" section for caving observed	
Surface Elevation (ft) Vertical Datum	490 NAVD88		Easting (X) Northing (Y)	1197914 671185		Coordinate System Horizontal Datum	WA State Plane South NAD83 (feet)		

Elevation (feet)	Depth (feet)	SAMPLE		Graphic Log	Group Classification	MATERIAL DESCRIPTION	Moisture Content (%)	Fines Content (%)	REMARKS
		Testing Sample	Sample Name Testing						
489	1		1 MC		SM	Red-brown silty fine to coarse sand with gravel, cobbles and trace organic matter (roots) (loose, moist)	9		
488	2				SP-SM	Brown fine sand with silt (loose, wet)	22	11	Slow groundwater seepage observed at 3¾ feet
487	3								
486	4		2 MC		GM	Grades to with gravel, dense	10	28	Minor to moderate caving observed from 6 to 10 feet
485	5								
484	6		3						
483	7				GM	Brown-blue silty fine to coarse gravel with sand (dense, wet)	10	28	
482	8		4						
481	9		5						
480	10		6						

Date: 2/5/21 Path: \\GEOENGINEERS.COM\WAN\PROJECTS\4565064\GINT\4565064.GPJ DBL\Library\Library\GEOENGINEERS_DF_STD_US_JUNE_2017.GLB\GERB_TESTPIT_4P_GEOTEC_%F

Notes: See Figure A-1 for explanation of symbols.
 The depths on the test pit logs are based on an average of measurements across the test pit and should be considered accurate to ½ foot.
 Coordinates Data Source: Horizontal approximated based on Aerial Imagery. Vertical approximated based on Google Earth.

Log of Test Pit PIT-4-20



Project: Benaroya Co South Hill Business & Technology Center
 Project Location: Puyallup, Washington
 Project Number: 4565-064-06

Figure A-10
 Sheet 1 of 1

Date Excavated	4/15/2020	Total Depth (ft)	10	Logged By	WCW	Excavator	Kelly's Excavating, Inc.	Groundwater not observed
				Checked By	DCO	Equipment	Takeuchi TB 138	Caving not observed
Surface Elevation (ft) Vertical Datum	530 NAVD88		Easting (X) Northing (Y)	1198108 671098		Coordinate System Horizontal Datum	WA State Plane South NAD83 (feet)	

Elevation (feet)	Depth (feet)	SAMPLE		Graphic Log	Group Classification	MATERIAL DESCRIPTION	Moisture Content (%)	Fines Content (%)	REMARKS
		Testing Sample	Sample Name Testing						
529	1		1		Duff	2 inches forest duff			
528	2		2		SM	Brown silty fine to medium sand with gravel (loose to medium dense, moist)			
527	3				GP	Brown fine to coarse gravel with sand (medium dense, moist)			
526	4		4		SM	Tan-brown silty fine sand with gravel (medium dense, moist)	17		
525	5		4		SM	Tan-brown silty fine sand with gravel (medium dense, moist)			
524	6				SPSM	Tan fine sand with silt (dense, moist)			
523	7				SPSM	Tan fine sand with silt (dense, moist)			
522	8		5		SPSM	Tan fine sand with silt (dense, moist)	24	8	
521	9				SPSM	Tan fine sand with silt (dense, moist)			
520	10		6		SPSM	Tan fine sand with silt (dense, moist)			

Date: 2/5/21 Path: \\GEOENGINEERS.COM\WAN\PROJECTS\4\4565064\GINT\4565064\GPI DBL\Library\Library\GEOENGINEERS_DF_STD_US_JUNE_2017.GLB\GERB_TESTPIT_5P_GEOTEC_%F

Notes: See Figure A-1 for explanation of symbols.
 The depths on the test pit logs are based on an average of measurements across the test pit and should be considered accurate to 1/2 foot.
 Coordinates Data Source: Horizontal approximated based on Aerial Imagery. Vertical approximated based on Google Earth.

Log of Test Pit PIT-5-20



Project: Benaroya Co South Hill Business & Technology Center
 Project Location: Puyallup, Washington
 Project Number: 4565-064-06

Figure A-11
 Sheet 1 of 1

Date Excavated	4/17/2020	Total Depth (ft)	8	Logged By	WCW	Excavator	Kelly's Excavating, Inc.	See "Remarks" section for groundwater observed
		Checked By	DCO	Equipment	Takeuchi TB 138			See "Remarks" section for caving observed
Surface Elevation (ft) Vertical Datum	550 NAVD88	Easting (X) Northing (Y)	1198109 670686	Coordinate System Horizontal Datum	WA State Plane South NAD83 (feet)			

Elevation (feet)	Depth (feet)	SAMPLE		Graphic Log	Group Classification	MATERIAL DESCRIPTION	Moisture Content (%)	Fines Content (%)	REMARKS
		Testing Sample	Sample Name Testing						
349	1		1 MC		SM	Red-brown silty fine to medium sand with occasional gravel and trace organic matter (loose, moist)	14		
348	2		2		SM	Brown silty fine sand (loose, moist)			
347	3				GP	Brown fine to coarse gravel with sand (medium dense, moist)	5	5	Minor to moderate caving observed from 3 to 8 feet
346	4		2 W						
345	5				GP	Gray and brown fine to coarse gravel with sand and occasional cobbles (medium dense, moist to wet)	6	1	Moderate groundwater seepage observed at 6 feet following PIT saturation
344	6		2 A						
343	7								
342	8		5						

Notes: See Figure A-1 for explanation of symbols.
The depths on the test pit logs are based on an average of measurements across the test pit and should be considered accurate to 1/2 foot.
Coordinates Data Source: Horizontal approximated based on Aerial Imagery. Vertical approximated based on Google Earth.

Log of Test Pit PIT-6-20



Project: Benaroya Co South Hill Business & Technology Center
Project Location: Puyallup, Washington
Project Number: 4565-064-06

Figure A-12
Sheet 1 of 1

Date: 2/5/21 Path: \\GEOENGINEERS.COM\WAN\PROJECTS\4565064\GINT\4565064\GPI\DBL\brary\Library\GEOENGINEERS_DF_STD_US_JUNE_2017.GLB\GER_TESTPIT_AP_GEOTEC_%F

Drilled	Start 7/8/2020	End 7/8/2020	Total Depth (ft)	26.5	Logged By Checked By	CJL DCO	Driller	Advance Drill Technologies	Drilling Method	Hollow-stem Auger
Hammer Data	Autohammer 140 (lbs) / 30 (in) Drop		Drilling Equipment		Diedrich D-50 Turbo (Track-Mounted)		DOE Well I.D.: BMM217 A 2-in well was installed on 7/8/2020 to a depth of 25 ft.			
Surface Elevation (ft) Vertical Datum		505 NAVD88		Top of Casing Elevation (ft)						
Easting (X) Northing (Y)		1198079 670882		Horizontal Datum		WA State Plane South NAD83 (feet)		Groundwater Date Measured	Depth to Water (ft)	Elevation (ft)
								12/18/2020	15.30	489.70
Notes:										

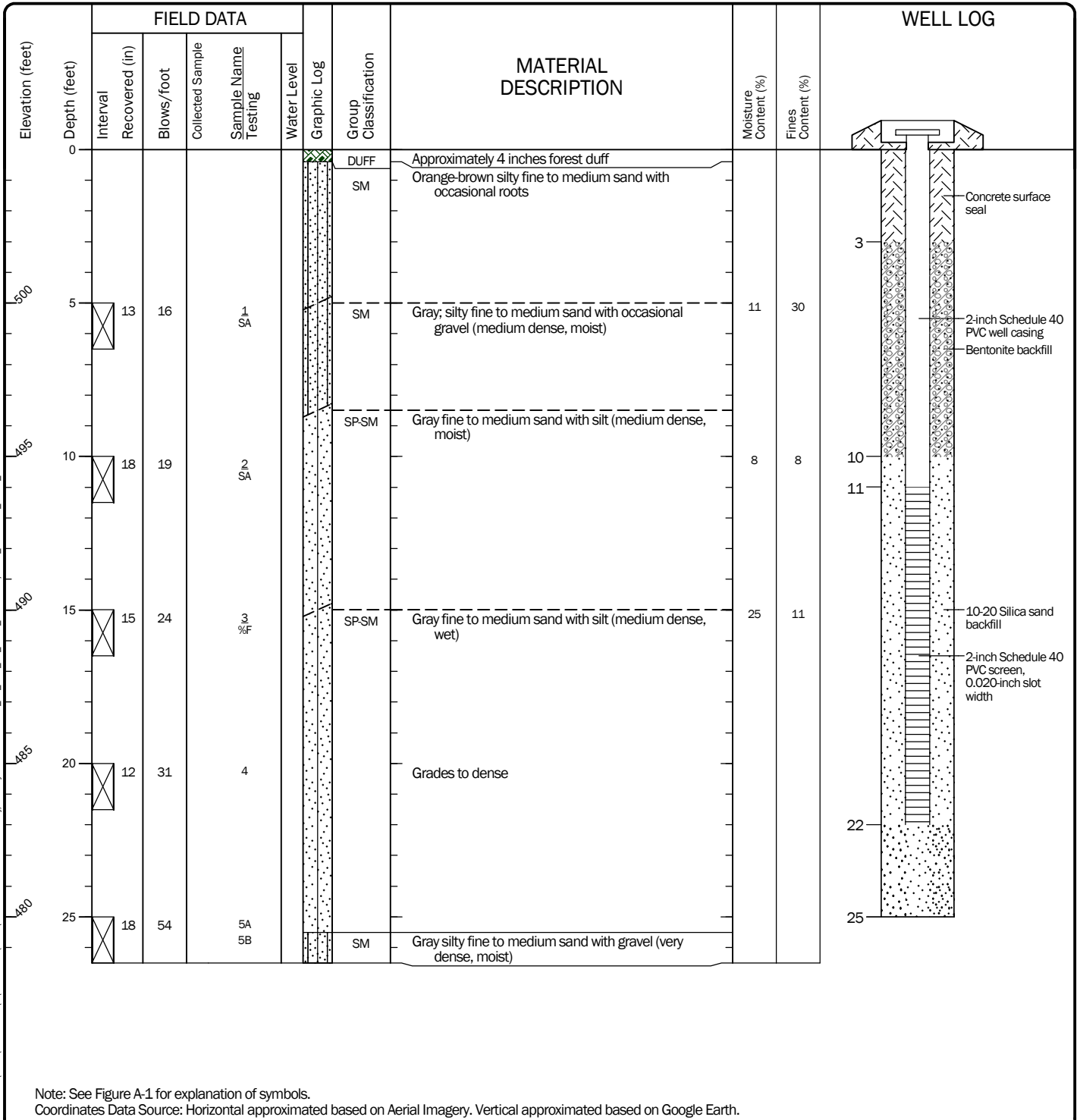

Log of Monitoring Well MW-1-20



Project: Benaroya Co South Hill Business & Technology Center
 Project Location: Puyallup, Washington
 Project Number: 4565-064-06

Date: 2/5/21 Path: \\GEOENGINEERS\COM\WAN\PROJECTS\4565-064\GINT\4565-064-06\GPI\DBL\Library\Library\GEOENGINEERS_DF_STD_US_JUNE_2017_GLB\GERB_GEO TECH_WELL_MF

Drilled	Start 7/8/2020	End 7/8/2020	Total Depth (ft)	11.5	Logged By Checked By	CJL DCO	Driller	Advance Drill Technologies	Drilling Method	Hollow-stem Auger	
Hammer Data	Autohammer 140 (lbs) / 30 (in) Drop				Drilling Equipment	Diedrich D-50 Turbo (Track-Mounted)			DOE Well I.D.: BMM-216 A 2-in well was installed on 7/8/2020 to a depth of 11.5 ft.		
Surface Elevation (ft) Vertical Datum		499 NAVD88			Top of Casing Elevation (ft)						
Easting (X) Northing (Y)		1198044 670603			Horizontal Datum		WA State Plane South NAD83 (feet)		Groundwater Date Measured	Depth to Water (ft) Elevation (ft)	12/18/2020 8.55 490.45
Notes:											

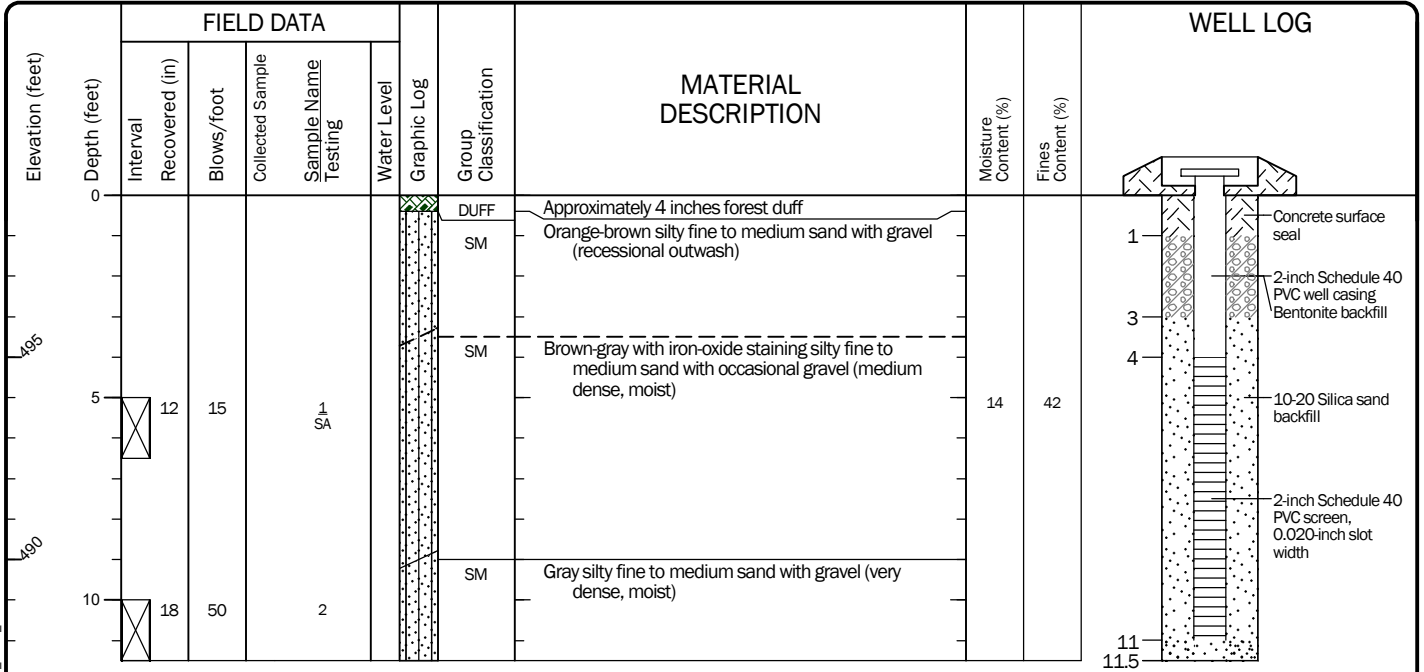

Note: See Figure A-1 for explanation of symbols.
Coordinates Data Source: Horizontal approximated based on Aerial Imagery. Vertical approximated based on Google Earth.

Log of Monitoring Well MW-2-20



Project: Benaroya Co South Hill Business & Technology Center
Project Location: Puyallup, Washington
Project Number: 4565-064-06

Date: 2/5/21 Path: \\GEOENGINEERS\COMMON\PROJECTS\4565-064\GINT\4565064\GPI DBL\Library\Library\GEOENGINEERS_DF_STD_US_JUNE_2017_GLB\GER_GEO TECH_WELL_WF

Drilled	Start 7/8/2020	End 7/8/2020	Total Depth (ft)	25.75	Logged By Checked By	CJL DCO	Driller	Advance Drill Technologies	Drilling Method	Hollow-stem Auger	
Surface Elevation (ft) Vertical Datum	500 NAVD88			Hammer Data	Autohammer 140 (lbs) / 30 (in) Drop			Drilling Equipment	Diedrich D-50 Turbo (Track-Mounted)		
Easting (X) Northing (Y)	1198046 670601			System Datum	WA State Plane South NAD83 (feet)			Groundwater not observed at time of exploration			
Notes:											

Elevation (feet)	FIELD DATA					Graphic Log	Group Classification	MATERIAL DESCRIPTION	Moisture Content (%)	Fines Content (%)	REMARKS
	Depth (feet)	Interval Recovered (in)	Blows/foot	Collected Sample	Sample Name Testing						
0						DUFF	Approximately 4 inches forest duff				Soil description inferred from observation of drilling cuttings
						SM	Orange-brown silty fine to medium sand with gravel (medium dense, moist)				
495	5	12	13		1A 1B	SM	Brown-gray with iron-oxide staining silty fine to medium sand (medium dense, moist) Gray silty fine to medium sand (medium dense, moist)				
490	10	18	48		2	SM	Brown-gray silty fine to medium sand with occasional gravel (dense, moist)				
485	15	18	28		3A 3B	GP SM	Gray fine gravel with sand and trace silt (medium dense, wet) Brown with iron-oxide staining silty fine sand (medium dense, moist)				
480	20	9	50/3"		4	SM	Gray silty fine to coarse sand with gravel (very dense, moist)				Drill chatter at 18 feet Drill chatter at 20 to 25 feet
475	25	6	50/4"		5						

Note: See Figure A-1 for explanation of symbols.
Coordinates Data Source: Horizontal approximated based on Aerial Imagery. Vertical approximated based on Google Earth.

Log of Boring B-3



Project: Benaroya Co South Hill Business & Technology Center
Project Location: Puyallup, Washington
Project Number: 4565-064-06

Figure A-15
Sheet 1 of 1

Date: 2/5/21 Path: \\GEOENGINEERS\COM\W\AN\PROJECTS\4\4565064\GINT\456506406.GPJ DBL\Library\Library\GEOENGINEERS_DF_STD_US_JUNE_2017.GLB\GER6_GEO TECH_STANDARD_%F_NO_GW

APPENDIX B

Laboratory Testing

APPENDIX B LABORATORY TESTING

Soil samples obtained from the explorations were transported to our laboratory and examined to confirm or modify field classifications, as well as to evaluate index properties of the soil samples. Representative samples were selected for laboratory testing consisting of the determination of the moisture content, percent passing the No. 200 sieve and grain size distribution. The tests were performed in general accordance with test methods of the ASTM International (ASTM) or other applicable procedures.

Moisture Content Testing

Moisture content tests were completed in general accordance with ASTM D 2216 for representative samples obtained from the explorations. The results of these tests are presented on the exploration logs in Appendix A at the depths at which the samples were obtained.

Percent Passing U.S. No. 200 Sieve (%F)

Selected samples were “washed” through the No. 200 mesh sieve to estimate the relative percentages of coarse and fine-grained particles in the soil. The percent passing value represents the percentage by weight of the sample finer than the U.S. No. 200 sieve. These tests were conducted to verify field descriptions and to estimate the fines content for analysis purposes. The tests were conducted in accordance with ASTM D 1140, and the results are shown on the exploration logs in Appendix A at the respective sample depths.

Grain Size Distribution

Sieve analyses were performed on selected samples in general accordance with ASTM D 422. The wet sieve analysis method was used to estimate the percentage of soil greater than the U.S. No. 200 mesh sieve. The results of the sieve analyses were plotted, classified in general accordance with the Unified Soil Classification System (USCS), and presented on Figures B-1 through B-5.

It should be noted that the sieve analyses were performed on soils obtained from samplers that have an opening size of 1½ inches so larger sized particles cannot be obtained by the samplers. Therefore, the sieve results do not account for soil particles that are larger than 1½ inches. Soils with larger sized materials are described in this report qualitatively based on visual observations and experience on projects where excavations were made into similar formations.

Organic Content and Cation Exchange

Organic content and cation exchange tests were completed on samples obtained from the explorations with additional grab samples collected at the proposed parking lot locations. The results of the test are provided in Table B-1.

TABLE B-1. RESULTS OF CATION EXCHANGE AND ORGANIC CONTENT

Exploration/Sample Location	Depth (feet)	Cation Exchange (meq/100g)	Organic Content (%)
PIT-5-20	4	6.7	2.0
PIT-6-20	4	3.5	1.2

As noted in Table B-1, cation exchange capacity (CEC) of the two samples range from 3.5 to 6.7, with an average value of 5.1. CEC values should be greater than 5 meq/100g (milliequivalent per gram) to be considered suitable for removing target pollutants. The organic content of the treatment soil should be greater than 1.0 percent. As shown above, the organic content percentage results were 1.2 and 2.0.

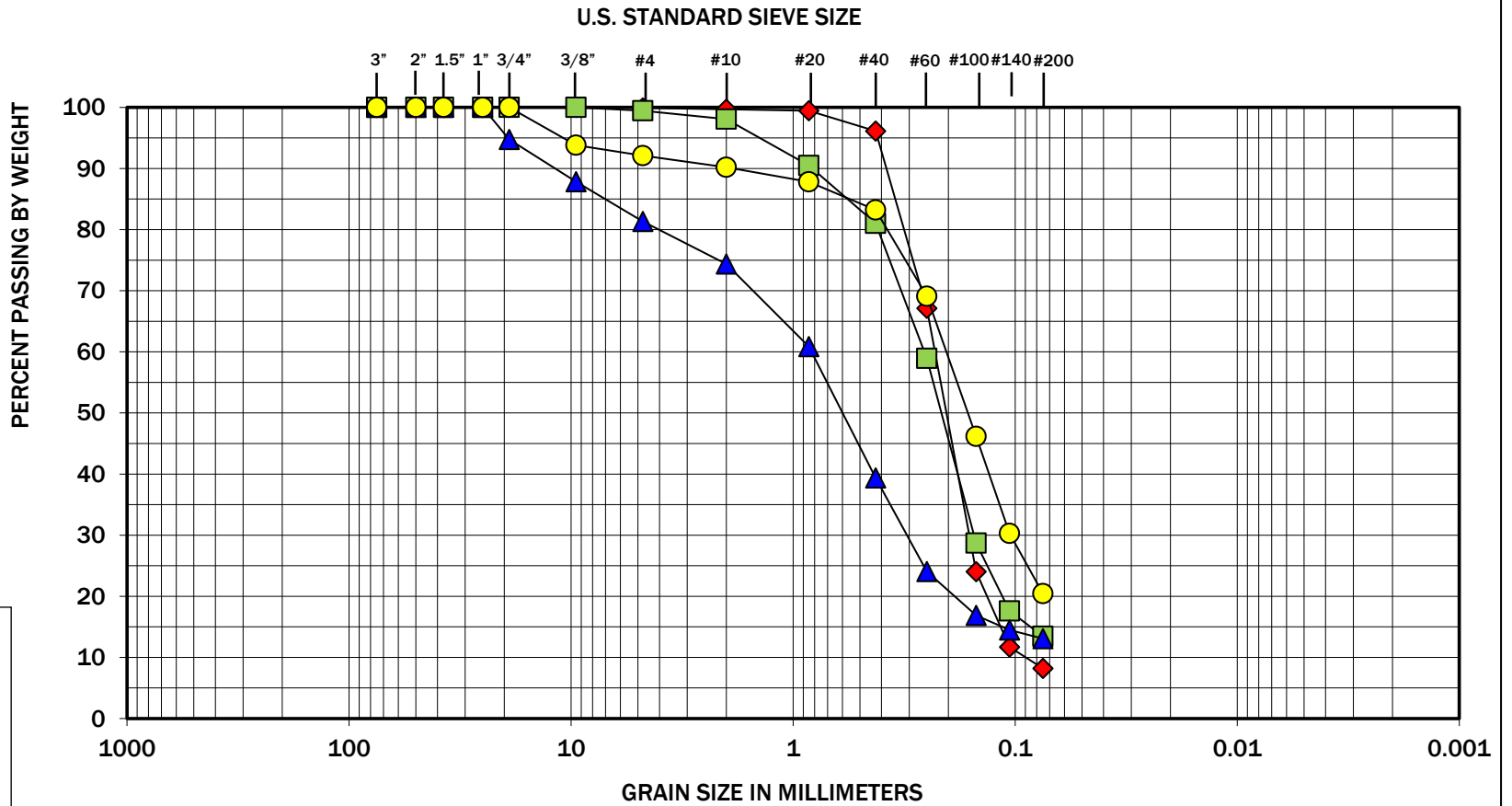

COBBLES	GRAVEL		SAND			SILT OR CLAY
	COARSE	FINE	COARSE	MEDIUM	FINE	

Symbol	Exploration Number	Depth (feet)	Moisture (%)	Soil Description
◆	TP-1-20	5	11	Fine sand with silt (SP-SM)
■	TP-2-20	5	16	Silty fine to medium sand (SM)
▲	TP-3-20	5	9	Silty fine to medium sand with gravel (SM)
●	TP-4-20	5	20	Silty fine sand with occasional gravel (SM)



Note: This report may not be reproduced, except in full, without written approval of GeoEngineers, Inc. Test results are applicable only to the specific sample on which they were performed, and should not be interpreted as representative of any other samples obtained at other times, depths or locations, or generated by separate operations or processes.

The grain size analysis results were obtained in general accordance with ASTM C 136. GeoEngineers 17425 NE Union Hill Road Ste 250, Redmond, WA 98052

Benaroya Co South Hill Business & Technology Center
Puyallup, Washington

Sieve Analysis Results

Figure B-1

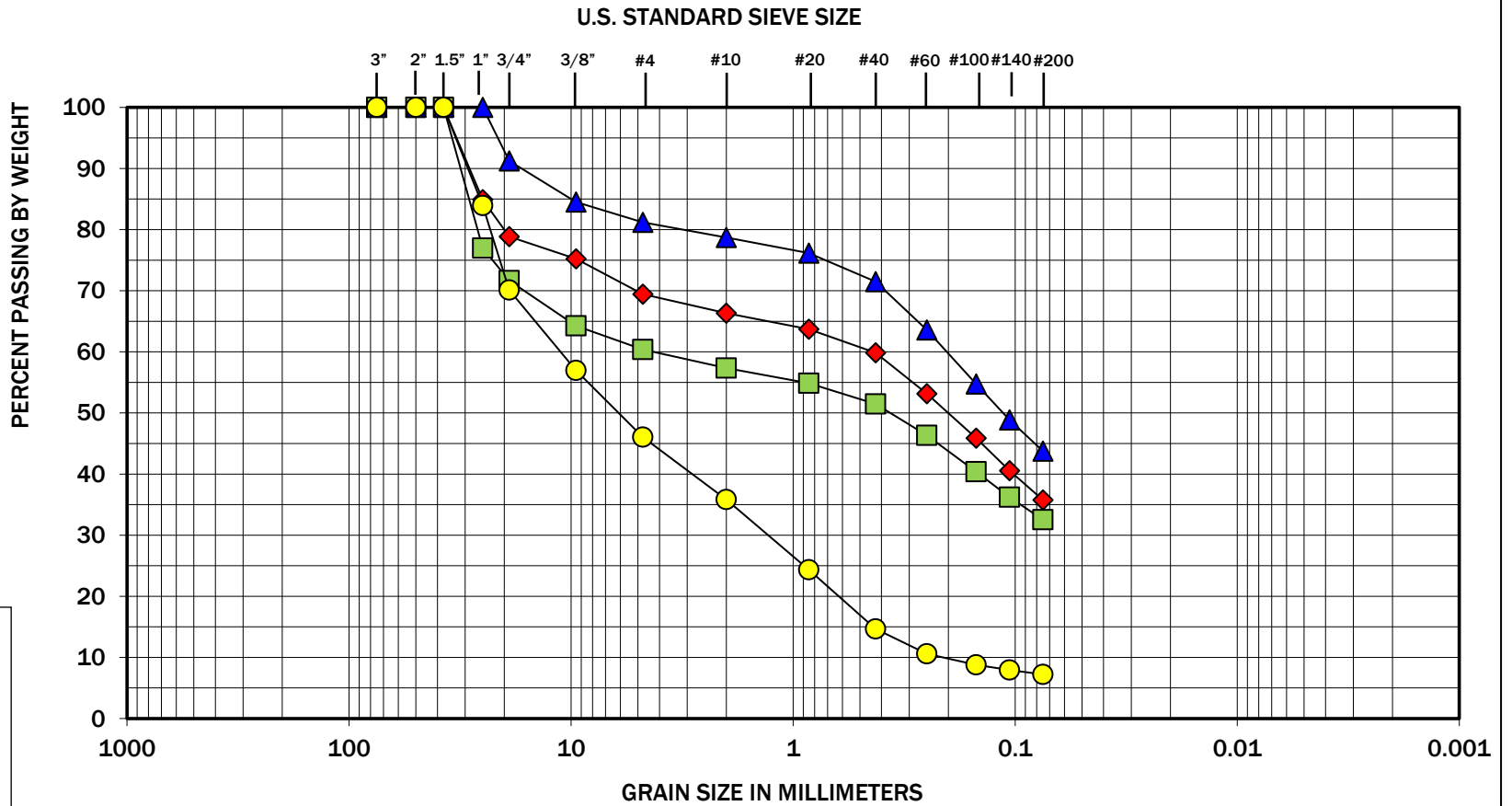

COBBLES	GRAVEL		SAND			SILT OR CLAY
	COARSE	FINE	COARSE	MEDIUM	FINE	

Symbol	Exploration Number	Depth (feet)	Moisture (%)	Soil Description
◆	TP-5-20	5	15	Silty fine sand with gravel (SM)
■	TP-5-20	7	13	Silty fine to coarse gravel with sand (GM)
▲	PIT-1	4	15	Silty fine sand with gravel (SM)
●	PIT-2	5	8	Fine to coarse gravel with silt and sand (GP-GM)



Note: This report may not be reproduced, except in full, without written approval of GeoEngineers, Inc. Test results are applicable only to the specific sample on which they were performed, and should not be interpreted as representative of any other samples obtained at other times, depths or locations, or generated by separate operations or processes.

The grain size analysis results were obtained in general accordance with ASTM C 136. GeoEngineers 17425 NE Union Hill Road Ste 250, Redmond, WA 98052

Benaroya Co South Hill Business & Technology Center
Puyallup, Washington

Sieve Analysis Results

Figure B-2

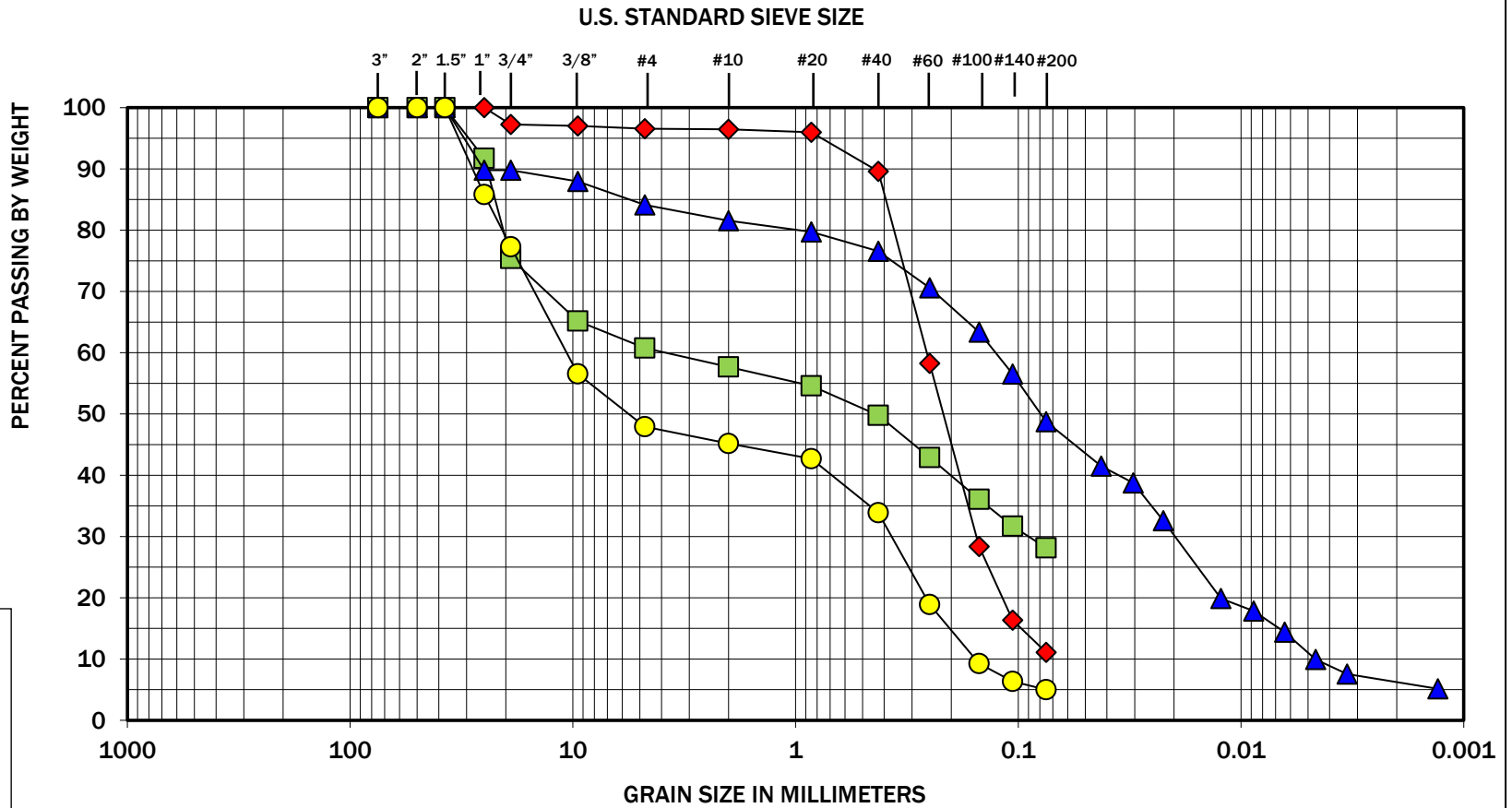

COBBLES	GRAVEL		SAND			SILT OR CLAY
	COARSE	FINE	COARSE	MEDIUM	FINE	

Symbol	Exploration Number	Depth (feet)	Moisture (%)	Soil Description
◆	PIT-4	4	22	Fine sand with silt (SP-SM)
■	PIT-4	8	10	Silty fine to coarse gravel with sand (GM)
▲	PIT-5	4	16	Silty fine sand with gravel (SM)
●	PIT-6	4	5	Fine to coarse gravel with sand (GP)



Note: This report may not be reproduced, except in full, without written approval of GeoEngineers, Inc. Test results are applicable only to the specific sample on which they were performed, and should not be interpreted as representative of any other samples obtained at other times, depths or locations, or generated by separate operations or processes.

The grain size analysis results were obtained in general accordance with ASTM C 136. GeoEngineers 17425 NE Union Hill Road Ste 250, Redmond, WA 98052

GEOENGINEERS

Figure B-3

Benaroya Co South Hill Business & Technology Center
Puyallup, Washington

Sieve Analysis Results

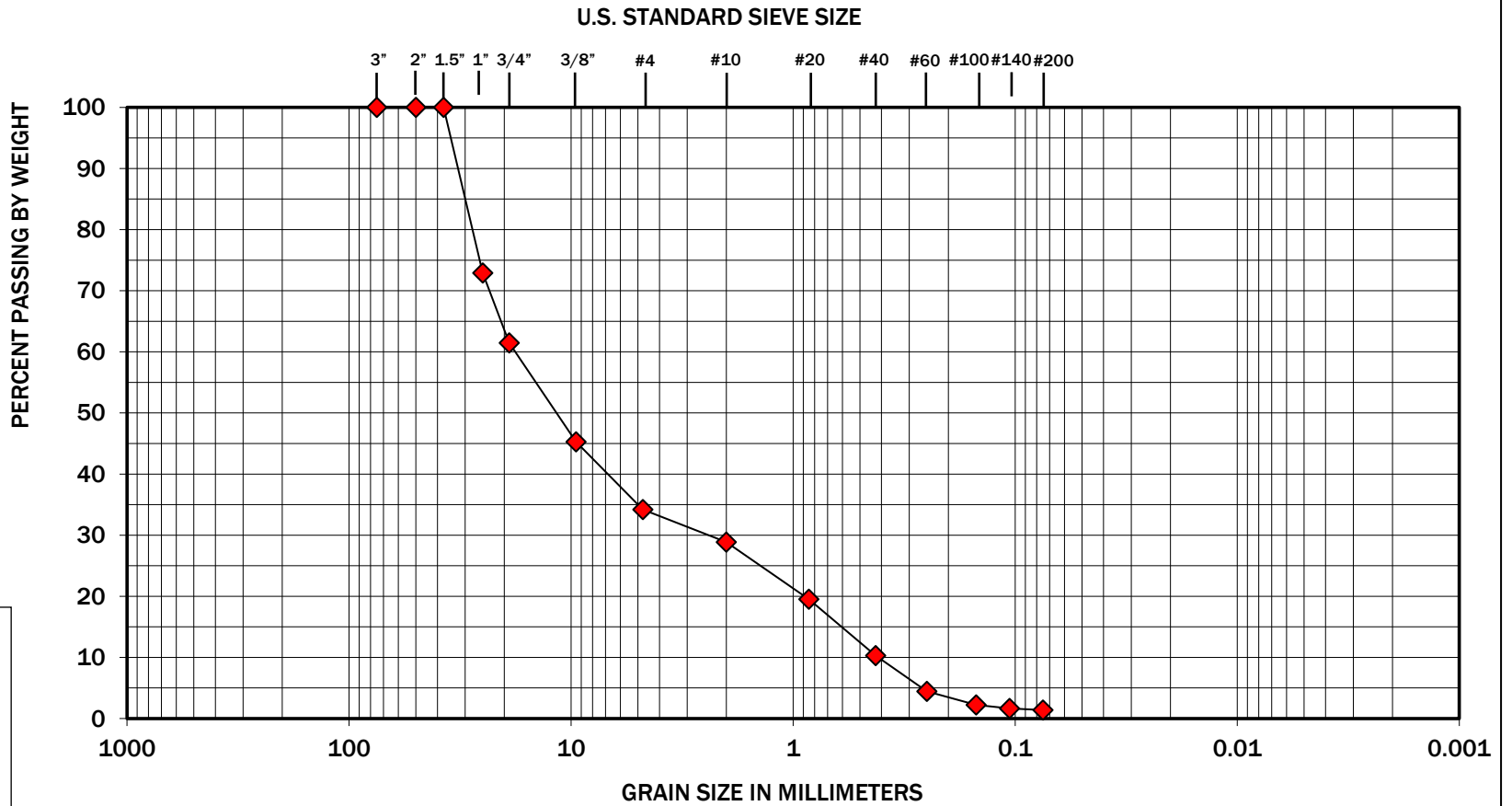

COBBLES	GRAVEL		SAND			SILT OR CLAY
	COARSE	FINE	COARSE	MEDIUM	FINE	

Symbol	Exploration Number	Depth (feet)	Moisture (%)	Soil Description
◆	PIT-6	6	6	Fine to coarse gravel with sand (GP)

Sieve Analysis Results

Benaroya Co South Hill Business & Technology Center
Puyallup, Washington

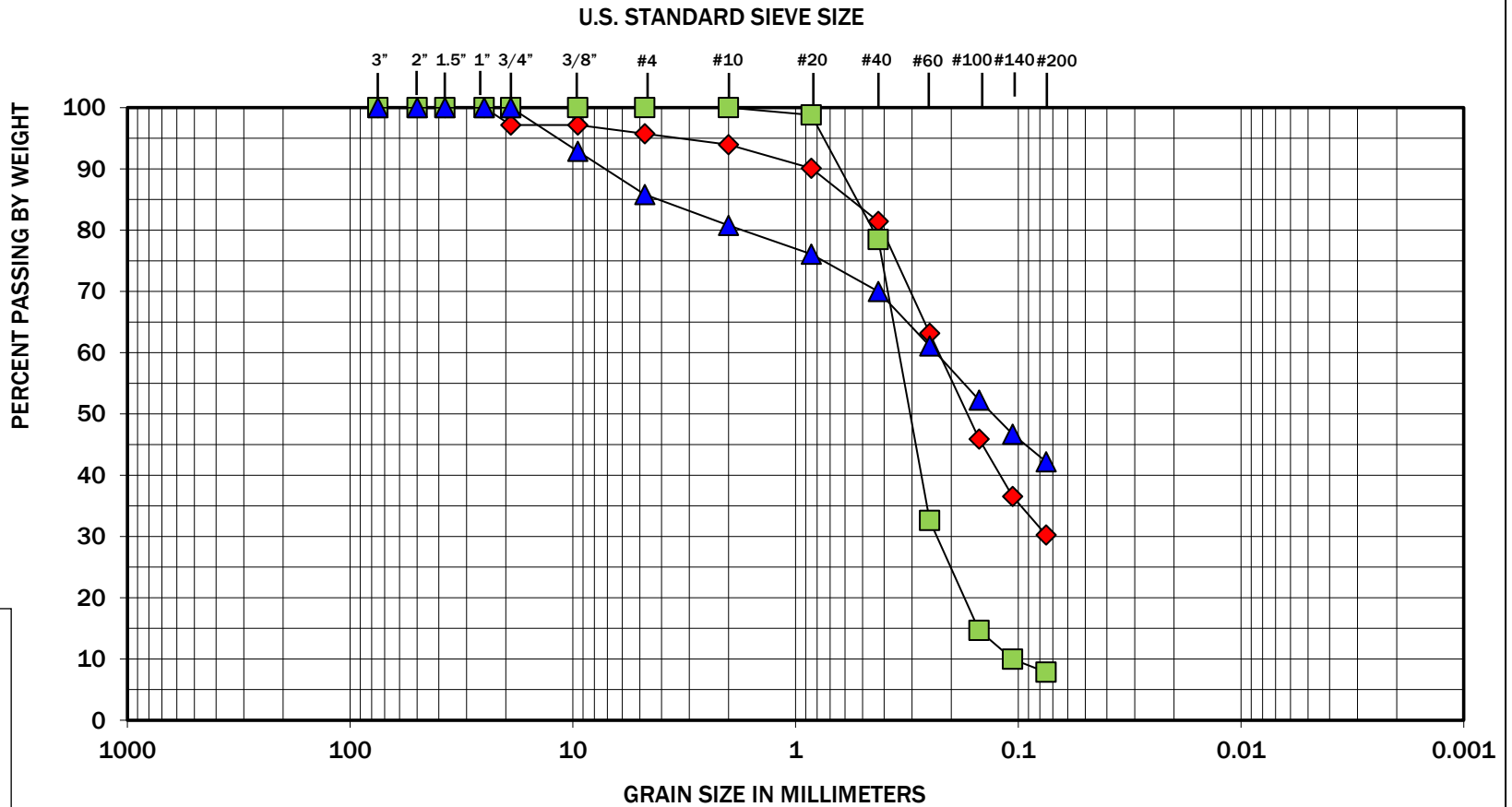

Figure B-4



Note: This report may not be reproduced, except in full, without written approval of GeoEngineers, Inc. Test results are applicable only to the specific sample on which they were performed, and should not be interpreted as representative of any other samples obtained at other times, depths or locations, or generated by separate operations or processes.

The grain size analysis results were obtained in general accordance with ASTM C 136. GeoEngineers 17425 NE Union Hill Road Ste 250, Redmond, WA 98052



COBBLES	GRAVEL		SAND			SILT OR CLAY
	COARSE	FINE	COARSE	MEDIUM	FINE	

Symbol	Exploration Number	Depth (feet)	Moisture (%)	Soil Description
◆	MW-1-20	5	11	Silty fine to medium sand (SM)
■	MW-1-20	10	8	Fine to medium sand with silt (SP-SM)
▲	MW-2-20	5	14	Silty fine to medium sand with occasional gravel (SM)



Note: This report may not be reproduced, except in full, without written approval of GeoEngineers, Inc. Test results are applicable only to the specific sample on which they were performed, and should not be interpreted as representative of any other samples obtained at other times, depths or locations, or generated by separate operations or processes.

The grain size analysis results were obtained in general accordance with ASTM C 136. GeoEngineers 17425 NE Union Hill Road Ste 250, Redmond, WA 98052

GEOENGINEERS
 Benaroya Co South Hill Business & Technology Center
 Puyallup, Washington
Sieve Analysis Results
Figure B-5



FIGURE B-6

SIEVE AND HYDROMETER ANALYSIS RESULTS

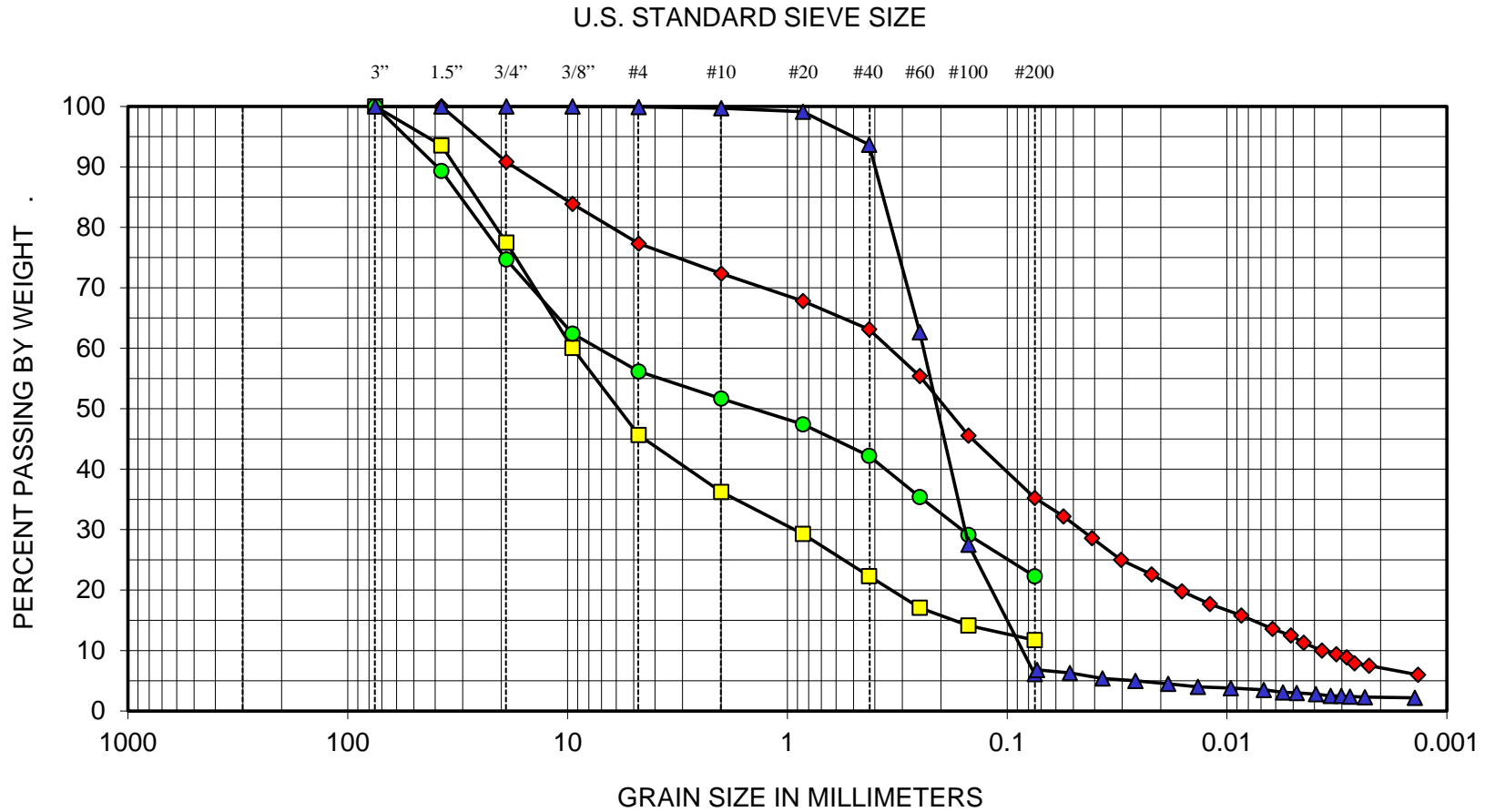

BOULDERS	COBBLES	GRAVEL		SAND			SILT OR CLAY
		COARSE	FINE	COARSE	MEDIUM	FINE	

SYMBOL	EXPLORATION NUMBER	DEPTH (ft)	SOIL CLASSIFICATION
◆	TP-1	3	Silty sand with gravel (SM)
■	TP-2	1	Poorly graded gravel with silt and sand (GP-GM)
●	TP-3	2	Silty gravel with sand (GM)
▲	TP-4	2	Poorly graded sand with silt (SP-SM)



FIGURE B-7

SIEVE AND HYDROMETER ANALYSIS RESULTS

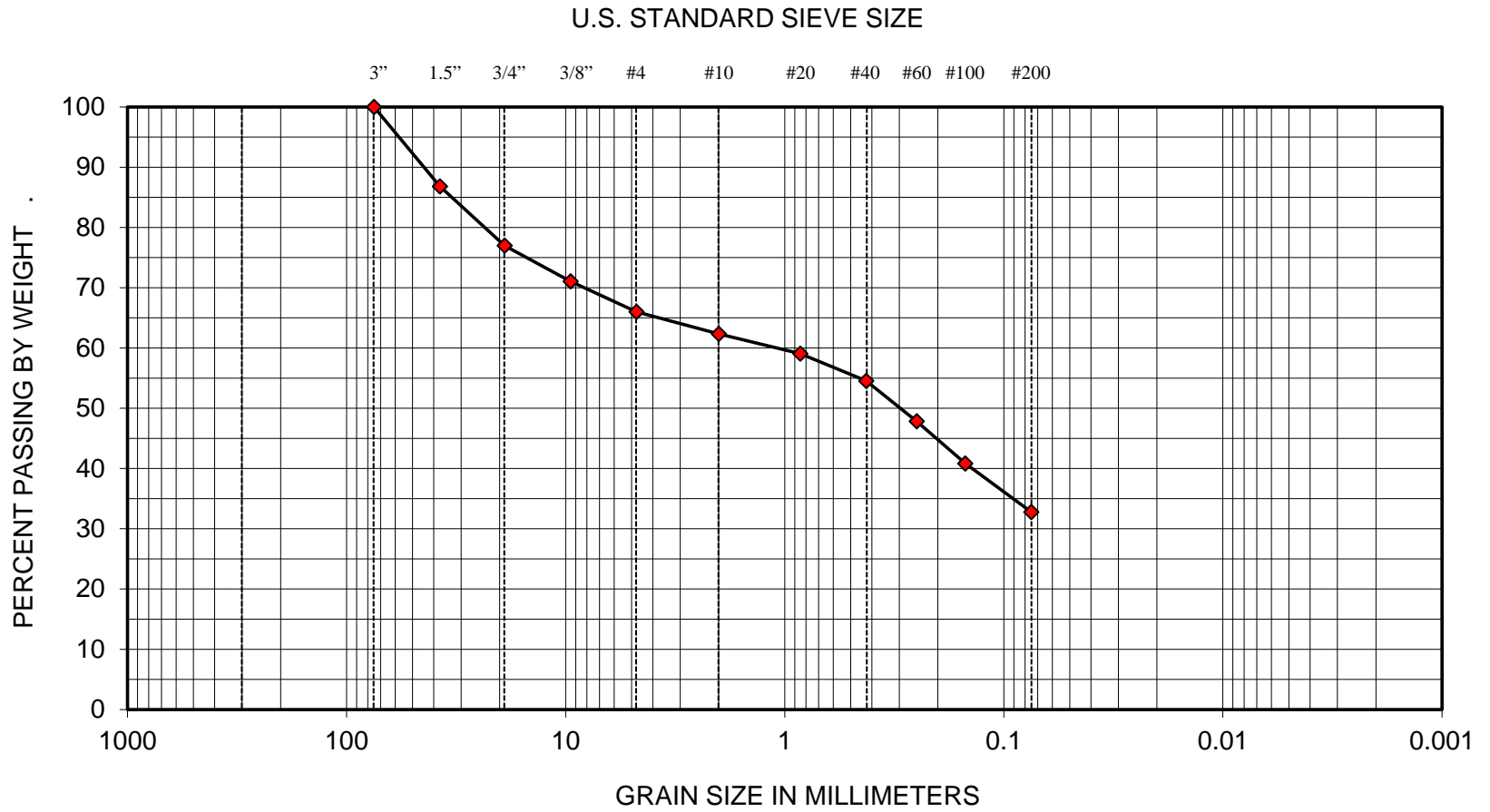

BOULDERS	COBBLES	GRAVEL		SAND			SILT OR CLAY
		COARSE	FINE	COARSE	MEDIUM	FINE	

SYMBOL	EXPLORATION NUMBER	DEPTH (ft)	SOIL CLASSIFICATION
◆	TP-4	6	Silty gravel with sand (GM)

APPENDIX C
Report Guidelines and Limitations for Use

APPENDIX C REPORT LIMITATIONS AND GUIDELINES FOR USE¹

This appendix provides information to help you manage your risks with respect to the use of this report.

Geotechnical Services Are Performed for Specific Purposes, Persons and Projects

This report has been prepared for the exclusive use of the Benaroya Company LLC and other project team members for the East Parking Lot Expansion project at the South Hill Business and Technology Center in Puyallup, Washington. This report is not intended for use by others, and the information contained herein is not applicable to other sites.

GeoEngineers structures our services to meet the specific needs of our clients. For example, a geotechnical or geologic study conducted for a civil engineer or architect may not fulfill the needs of a construction contractor or even another civil engineer or architect that are involved in the same project. Because each geotechnical or geologic study is unique, each geotechnical engineering or geologic report is unique, prepared solely for the specific client and project site. Our report is prepared for the exclusive use of our Client. No other party may rely on the product of our services unless we agree in advance to such reliance in writing. This is to provide our firm with reasonable protection against open-ended liability claims by third parties with whom there would otherwise be no contractual limits to their actions. Within the limitations of scope, schedule and budget, our services have been executed in accordance with our Agreement with the Client and generally accepted geotechnical practices in this area at the time this report was prepared. This report should not be applied for any purpose or project except the one originally contemplated.

A Geotechnical Engineering or Geologic Report Is Based on a Unique Set of Project-Specific Factors

This report has been prepared for the East Parking Lot Expansion project at the South Hill Business and Technology Center in Puyallup, Washington. GeoEngineers considered a number of unique, project-specific factors when establishing the scope of services for this project and report. Unless GeoEngineers specifically indicates otherwise, do not rely on this report if it was:

- Not prepared for you,
- Not prepared for your project,
- Not prepared for the specific site explored, or
- Completed before important project changes were made.

For example, changes that can affect the applicability of this report include those that affect:

- The function of the proposed structure;
- Elevation, configuration, location, orientation or weight of the proposed structure;

¹ Developed based on material provided by ASFE, Professional Firms Practicing in the Geosciences; www.asfe.org .

- Composition of the design team; or
- Project ownership.

If important changes are made after the date of this report, GeoEngineers should be given the opportunity to review our interpretations and recommendations and provide written modifications or confirmation, as appropriate.

Subsurface Conditions Can Change

This geotechnical or geologic report is based on conditions that existed at the time the study was performed. The findings and conclusions of this report may be affected by the passage of time, by manmade events such as construction on or adjacent to the site, or by natural events such as floods, earthquakes, slope instability or groundwater fluctuations. Always contact GeoEngineers before applying a report to determine if it remains applicable.

Most Geotechnical and Geologic Findings Are Professional Opinions

Our interpretations of subsurface conditions are based on field observations from widely spaced sampling locations at the site. Site exploration identifies subsurface conditions only at those points where subsurface tests are conducted or samples are taken. GeoEngineers reviewed field and laboratory data and then applied our professional judgment to render an opinion about subsurface conditions throughout the site. Actual subsurface conditions may differ, sometimes significantly, from those indicated in this report. Our report, conclusions and interpretations should not be construed as a warranty of the subsurface conditions.

Geotechnical Engineering Report Recommendations Are Not Final

Do not over-rely on the preliminary construction recommendations included in this report. These recommendations are not final, because they were developed principally from GeoEngineers' professional judgment and opinion. GeoEngineers' recommendations can be finalized only by observing actual subsurface conditions revealed during construction. GeoEngineers cannot assume responsibility or liability for this report's recommendations if we do not perform construction observation.

Sufficient monitoring, testing and consultation by GeoEngineers should be provided during construction to confirm that the conditions encountered are consistent with those indicated by the explorations, to provide recommendations for design changes should the conditions revealed during the work differ from those anticipated, and to evaluate whether or not earthwork activities are completed in accordance with our recommendations. Retaining GeoEngineers for construction observation for this project is the most effective method of managing the risks associated with unanticipated conditions.

A Geotechnical Engineering or Geologic Report Could Be Subject to Misinterpretation

Misinterpretation of this report by other design team members can result in costly problems. You could lower that risk by having GeoEngineers confer with appropriate members of the design team after submitting the report. Also retain GeoEngineers to review pertinent elements of the design team's plans and specifications. Contractors can also misinterpret a geotechnical engineering or geologic report. Reduce that risk by having GeoEngineers participate in pre-bid and preconstruction conferences, and by providing construction observation.

Do Not Redraw the Exploration Logs

Geotechnical engineers and geologists prepare final boring and testing logs based upon their interpretation of field logs and laboratory data. To prevent errors or omissions, the logs included in a geotechnical engineering or geologic report should never be redrawn for inclusion in architectural or other design drawings. Only photographic or electronic reproduction is acceptable, but recognize that separating logs from the report can elevate risk.

Give Contractors a Complete Report and Guidance

Some owners and design professionals believe they can make contractors liable for unanticipated subsurface conditions by limiting what they provide for bid preparation. To help prevent costly problems, give contractors the complete geotechnical engineering or geologic report, but preface it with a clearly written letter of transmittal. In that letter, advise contractors that the report was not prepared for purposes of bid development and that the report's accuracy is limited; encourage them to confer with GeoEngineers and/or to conduct additional study to obtain the specific types of information they need or prefer. A pre-bid conference can also be valuable. Be sure contractors have sufficient time to perform additional study. Only then might an owner be in a position to give contractors the best information available, while requiring them to at least share the financial responsibilities stemming from unanticipated conditions. Further, a contingency for unanticipated conditions should be included in your project budget and schedule.

Contractors are Responsible for Site Safety on Their Own Construction Projects

Our geotechnical recommendations are not intended to direct the contractor's procedures, methods, schedule or management of the work site. The contractor is solely responsible for job site safety and for managing construction operations to minimize risks to on-site personnel and to adjacent properties.

Read These Provisions Closely

Some clients, design professionals and contractors may not recognize that the geoscience practices (geotechnical engineering or geology) are far less exact than other engineering and natural science disciplines. This lack of understanding can create unrealistic expectations that could lead to disappointments, claims and disputes. GeoEngineers includes these explanatory "limitations" provisions in our reports to help reduce such risks. Please confer with GeoEngineers if you are unclear how these "Report Limitations and Guidelines for Use" apply to your project or site.

Geotechnical, Geologic and Environmental Reports Should Not be Interchanged

The equipment, techniques and personnel used to perform an environmental study differ significantly from those used to perform a geotechnical or geologic study and vice versa. For that reason, a geotechnical engineering or geologic report does not usually relate any environmental findings, conclusions or recommendations; e.g., about the likelihood of encountering underground storage tanks or regulated contaminants. Similarly, environmental reports are not used to address geotechnical or geologic concerns regarding a specific project.

Biological Pollutants

GeoEngineers' Scope of Work specifically excludes the investigation, detection, prevention or assessment of the presence of Biological Pollutants. Accordingly, this report does not include any interpretations, recommendations, findings, or conclusions regarding the detecting, assessing, preventing or abating of

Biological Pollutants and no conclusions or inferences should be drawn regarding Biological Pollutants, as they may relate to this project. The term “Biological Pollutants” includes, but is not limited to, molds, fungi, spores, bacteria, and viruses, and/or any of their byproducts.

If Client desires these specialized services, they should be obtained from a consultant who offers services in this specialized field.

Environmental Regulations Are Always Evolving

Some substances may be present in the vicinity of the subject property in quantities or under conditions that may have led, or may lead, to contamination of the subject property, but are not included in current local, state or federal regulatory definitions of hazardous substances or do not otherwise present current potential liability. GeoEngineers cannot be responsible if the standards for appropriate inquiry, or regulatory definitions of hazardous substances, change or if more stringent environmental standards are developed in the future.

Uncertainty May Remain Even After This Environmental Soil Sampling Is Completed

Performance of environmental soil sampling is intended to reduce uncertainty regarding the potential for contamination in connection with a property, but no environmental sampling can wholly eliminate that uncertainty. Our interpretation of subsurface conditions in this study is based on field observations and chemical analytical data from widely spaced sampling locations. It is always possible that contamination exists in areas that were not explored, sampled or analyzed.

Soil and Groundwater End Use

The cleanup levels referenced in this report are site- and situation-specific. The cleanup levels may not be applicable for other properties or for other on-site uses of the affected soil and/or groundwater. Note that hazardous substances may be present in some of the on-site soil and/or groundwater at detectable concentrations that are less than the referenced cleanup levels. GeoEngineers should be contacted prior to the export of soil or groundwater from the subject property or reuse of the affected soil or groundwater on-site to evaluate the potential for associated environmental liabilities. We are unable to assume responsibility for potential environmental liability arising out of the transfer of soil and/or groundwater from the subject property to another location or its reuse on-site in instances that we did not know or could not control.

Appendix B

Grading & Storm Plans

PATH: u:\P30\Projects\Clients\312-Benaroya\217-7312-004-SHB&TCParkingExpansion\995\en\CAD\DWG PLOTTED BY: patitus DATE: Friday, February 25, 2022 1:06:06 PM LAYOUT: SD-00

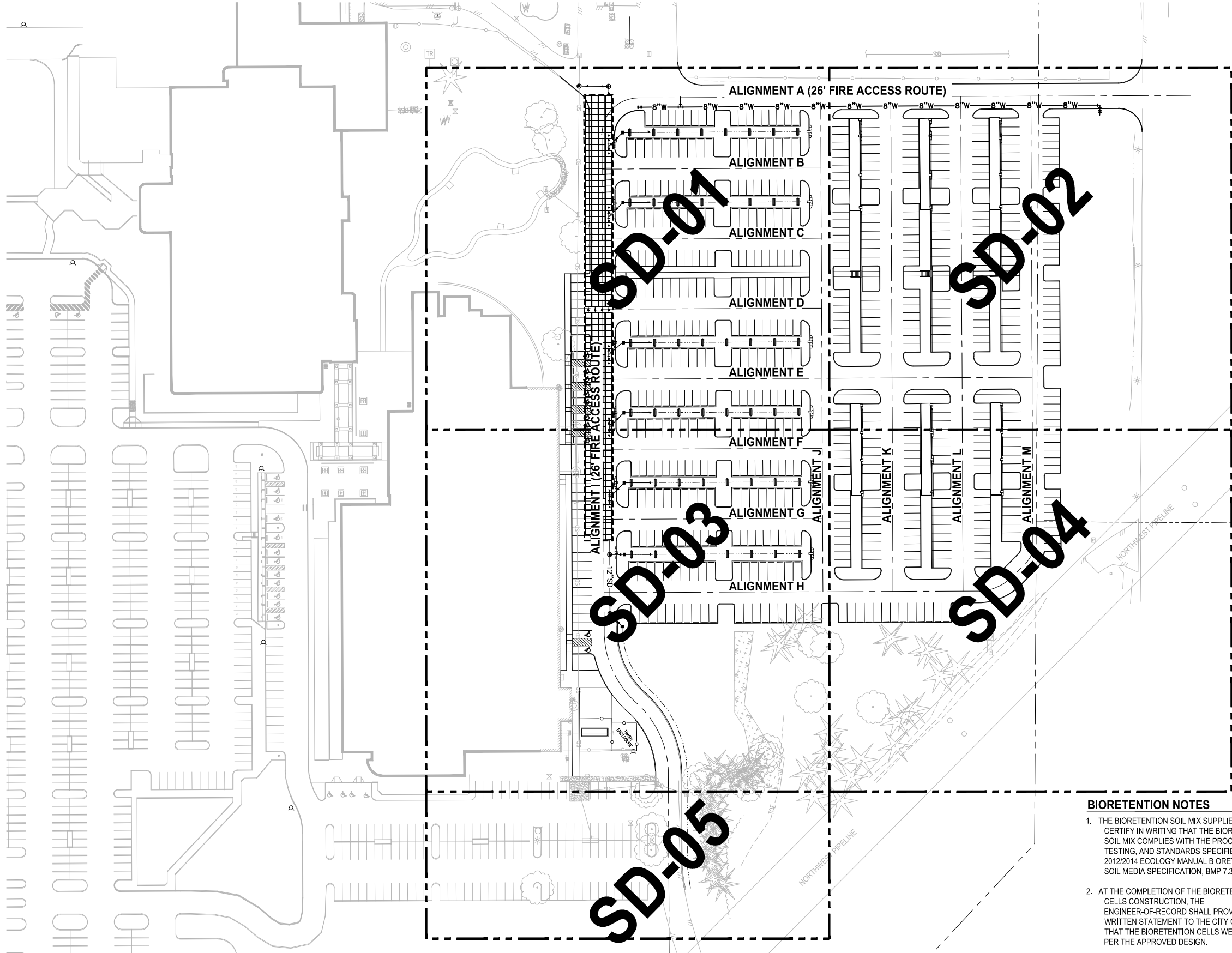

SCALE IN FEET
0 50 100

APPROVED
BY: CITY OF PUYALLUP
ENGINEERING DEPARTMENT
DATE:
NOTE:
This approval is void after 1 year from approval date. The City will not be responsible for errors and/or omissions on these plans.
Field conditions may dictate changes to these plans as determined by the City Engineer.

LEGEND:

- PROPERTY LINE
- ROADWAY CENTERLINE
- DEPRESSED CURB PER WSDOT STD PLAN F-10.12-04
- CURB AND GUTTER PER WSDOT STD PLAN F-10.12-04
- CONCRETE WALL
- ASPHALT SURFACE
- CEMENT CONCRETE SIDEWALK
- BIORETENTION SOIL MEDIA PER SWMM BMP T7.30
- STORM DRAINAGE PIPE (SIZE PER PLAN)
- CATCH BASIN (TYPE PER PLAN)
- STORM SEWER MANHOLE
- COMPACT PARKING STALL 8'x17'
- STANDARD PARKING STALL 9'x20'
- STANDARD PARKING STALL 9'x20' WITH ELECTRIC VEHICLE CHARGING STATION

GENERAL NOTES:

1. CONTRACTOR SHALL FURNISH AND INSTALL ALL MATERIALS AND EQUIPMENT NECESSARY TO COMPLETE THIS WORK.
2. ALL STORM DRAINAGE STRUCTURES CALL OUT TO CENTER OF STRUCTURE.
3. PIPE LENGTHS ARE FOR CALCULATION PURPOSES ONLY. BID QUANTITIES SHALL BE CALCULATED AS REQUIRED.

ROADWAY CONSTRUCTION NOTES:

1. INSTALL CURB AND GUTTER, SEE CITY OF PUYALLUP STANDARD NO. 01.02.09 ON SHEET SD-06.
2. INSTALL TRAFFIC CURB, SEE WSDOT STANDARD PLAN F-10.12-04 ON SHEET SD-06.
3. INSTALL 1' WIDE DEPRESSED CURB, SEE WSDOT STANDARD PLAN F-10.12-04 ON SHEET SD-06.
4. INSTALL WHEEL STOP, SEE WSDOT STANDARD PLAN M-17.10-22 ON SHEET SD-06.
5. INSTALL SIDEWALK, SEE CITY OF PUYALLUP STANDARD NO. 01.02.01 ON SHEET SD-07.
6. INSTALL PARKING STALL PAINT MARKINGS, SEE WSDOT STANDARD PLAN M-17.10-02 ON SHEET SD-06.
7. INSTALL COMPLETE ADA PARKING STALLS CHANNELIZATION AND SIGNS, SEE WSDOT STANDARD PLAN M-17.10-02 ON SHEET SD-06. ALL SLOPES SHALL BE LESS THAN 2% IN ALL DIRECTIONS.
8. INSTALL CEMENT CONCRETE PARALLEL CURB RAMP, SEE WSDOT STANDARD PLAN F-40.12-03 ON SHEET SD-06.
9. CURB AND GUTTER TO CONTINUE BEHIND TRAFFIC CURB OF LANDSCAPE ISLAND.
10. INSTALL ZURN P12-PGR ANTI-SLIP ADA GRATE OR APPROVED EQUIVALENT PER DETAIL ON SD-07.

BIORETENTION NOTES

1. THE BIORETENTION SOIL MIX SUPPLIER SHALL CERTIFY IN WRITING THAT THE BIORETENTION SOIL MIX COMPLIES WITH THE PROCESSES, TESTING, AND STANDARDS SPECIFIED BY THE 2012/2014 ECOLOGY MANUAL BIORETENTION SOIL MEDIA SPECIFICATION, BMP 7.30
2. AT THE COMPLETION OF THE BIORETENTION CELLS CONSTRUCTION, THE ENGINEER-OF-RECORD SHALL PROVIDE A WRITTEN STATEMENT TO THE CITY OF PUYALLUP THAT THE BIORETENTION CELLS WERE BUILT PER THE APPROVED DESIGN.

STORM DRAINAGE CONSTRUCTION NOTES:

1. INSTALL STORM SEWER MANHOLE, SEE CITY OF PUYALLUP STANDARD NO. 02.01.01 ON SHEET SD-07.
2. INSTALL CONCRETE CURB INLET AND CONCRETE SPLASH PAD PER DETAIL 1 ON SD-06.
3. INSTALL CATCH BASIN TYPE 1, SEE CITY OF PUYALLUP STANDARD NO. 02.01.03 ON SHEET SD-07.
4. INSTALL CATCH BASIN TYPE II WITH BIORETENTION OVERFLOW OUTLET STRUCTURE, SEE CITY OF PUYALLUP STANDARD NO. 02.01.04 ON SHEET SD-07 AND NO.02.07.03 ON SD-07.
5. INSTALL STORM DRAIN CLEAN OUT.

NOTE:
SYMBOLS NOT TO SCALE

100% REVIEW SUBMITTAL

REVISIONS	DATE	BY	DESIGNED WZG

ONE INCH AT FULL SCALE.
IF NOT, SCALE ACCORDINGLY.
FILE NAME
04-P30731200C-SD-HS
JOB No.
217-7312-004
DATE
MARCH 2022

Parametrix
ENGINEERING, PLANNING, ENVIRONMENTAL SCIENCES
1019 39TH AVENUE SE, SUITE 100 | PUYALLUP, WA 98374
P 253.604.6600
WWW.PARAMETRIX.COM

PROJECT NAME
SOUTH HILL BUSINESS & TECHNOLOGY CENTER PARKING EXPANSION
PUYALLUP, WA

HARDSCAPE & STORM DRAINAGE PLAN COMPOSITE

DRAWING NO.
19 OF 58
SD-00

APPROVED
 BY: CITY OF PUYALLUP
 ENGINEERING DEPARTMENT
 DATE: _____
 NOTE:
 This approval is void after 1 year from approval date. The City will not be responsible for errors and/or omissions on these plans.
 Field conditions may dictate changes to these plans as determined by the City Engineer.

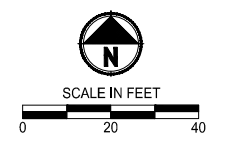

- LEGEND:**
- PROPERTY LINE
 - ROADWAY CENTERLINE
 - DEPRESSED CURB PER WSDOT STD PLAN F-10.12-04
 - CURB AND GUTTER PER WSDOT STD PLAN F-10.12-04
 - CONCRETE WALL
 - ASPHALT SURFACE
 - CEMENT CONCRETE SIDEWALK
 - BIORETENTION SOIL MEDIA PER SWMM BMP T7.30
 - SD --- STORM DRAINAGE PIPE (SIZE PER PLAN)
 - CB --- CATCH BASIN (TYPE PER PLAN)
 - S --- STORM SEWER MANHOLE
 - C --- COMPACT PARKING STALL 8'x17'
 - S --- STANDARD PARKING STALL 9'x20'
 - EV --- STANDARD PARKING STALL 9'x20' WITH ELECTRIC VEHICLE CHARGING STATION

- GENERAL NOTES:**
- CONTRACTOR SHALL FURNISH AND INSTALL ALL MATERIALS AND EQUIPMENT NECESSARY TO COMPLETE THIS WORK.
 - ALL STORM DRAINAGE STRUCTURES CALL OUT TO CENTER OF STRUCTURE.
 - PIPE LENGTHS ARE FOR CALCULATION PURPOSES ONLY. BID QUANTITIES SHALL BE CALCULATED AS REQUIRED.

- ROADWAY CONSTRUCTION NOTES:**
- INSTALL CURB AND GUTTER, SEE CITY OF PUYALLUP STANDARD NO. 01.02.09 ON SHEET SD-06.
 - INSTALL TRAFFIC CURB, SEE WSDOT STANDARD PLAN F-10.12-04 ON SHEET SD-06.
 - INSTALL 1' WIDE DEPRESSED CURB, SEE WSDOT STANDARD PLAN F-10.12-04 ON SHEET SD-06.
 - INSTALL WHEEL STOP, SEE WSDOT STANDARD PLAN M-17.10-22 ON SHEET SD-06.
 - INSTALL SIDEWALK, SEE CITY OF PUYALLUP STANDARD NO. 01.02.01 ON SHEET SD-07.
 - INSTALL PARKING STALL PAINT MARKINGS, SEE WSDOT STANDARD PLAN M-17.10-02 ON SHEET SD-06.
 - INSTALL COMPLETE ADA PARKING STALLS CHANNELIZATION AND SIGNS, SEE WSDOT STANDARD PLAN M-17.10-02 ON SHEET SD-06. ALL SLOPES SHALL BE LESS THAN 2% IN ALL DIRECTIONS.
 - INSTALL CEMENT CONCRETE PARALLEL CURB RAMP, SEE WSDOT STANDARD PLAN F-40.12-03 ON SHEET SD-06.
 - CURB AND GUTTER TO CONTINUE BEHIND TRAFFIC CURB OF LANDSCAPE ISLAND.
 - INSTALL ZURN P12-PGR ANTI-SLIP ADA GRATE OR APPROVED EQUIVALENT PER DETAIL ON SD-07.

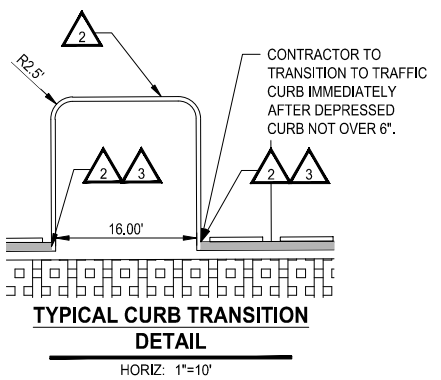

- BIORETENTION NOTES**
- THE BIORETENTION SOIL MIX SUPPLIER SHALL CERTIFY IN WRITING THAT THE BIORETENTION SOIL MIX COMPLIES WITH THE PROCESSES, TESTING, AND STANDARDS SPECIFIED BY THE 2012/2014 ECOLOGY MANUAL BIORETENTION SOIL MEDIA SPECIFICATION, BMP 7.30
 - AT THE COMPLETION OF THE BIORETENTION CELLS CONSTRUCTION, THE ENGINEER-OF-RECORD SHALL PROVIDE A WRITTEN STATEMENT TO THE CITY OF PUYALLUP THAT THE BIORETENTION CELLS WERE BUILT PER THE APPROVED DESIGN.

- STORM DRAINAGE CONSTRUCTION NOTES:**
- INSTALL STORM SEWER MANHOLE, SEE CITY OF PUYALLUP STANDARD NO. 02.01.01 ON SHEET SD-07.
 - INSTALL CONCRETE CURB INLET AND CONCRETE SPLASH PAD PER DETAIL 1 ON SD-06.
 - INSTALL CATCH BASIN TYPE 1, SEE CITY OF PUYALLUP STANDARD NO. 02.01.03 ON SHEET SD-07.
 - INSTALL CATCH BASIN TYPE II WITH BIORETENTION OVERFLOW OUTLET STRUCTURE, SEE CITY OF PUYALLUP STANDARD NO. 02.01.04 ON SHEET SD-07 AND NO.02.07.03 ON SD-07.
 - INSTALL STORM DRAIN CLEAN OUT.

NOTE: SYMBOLS NOT TO SCALE **100% REVIEW SUBMITTAL**

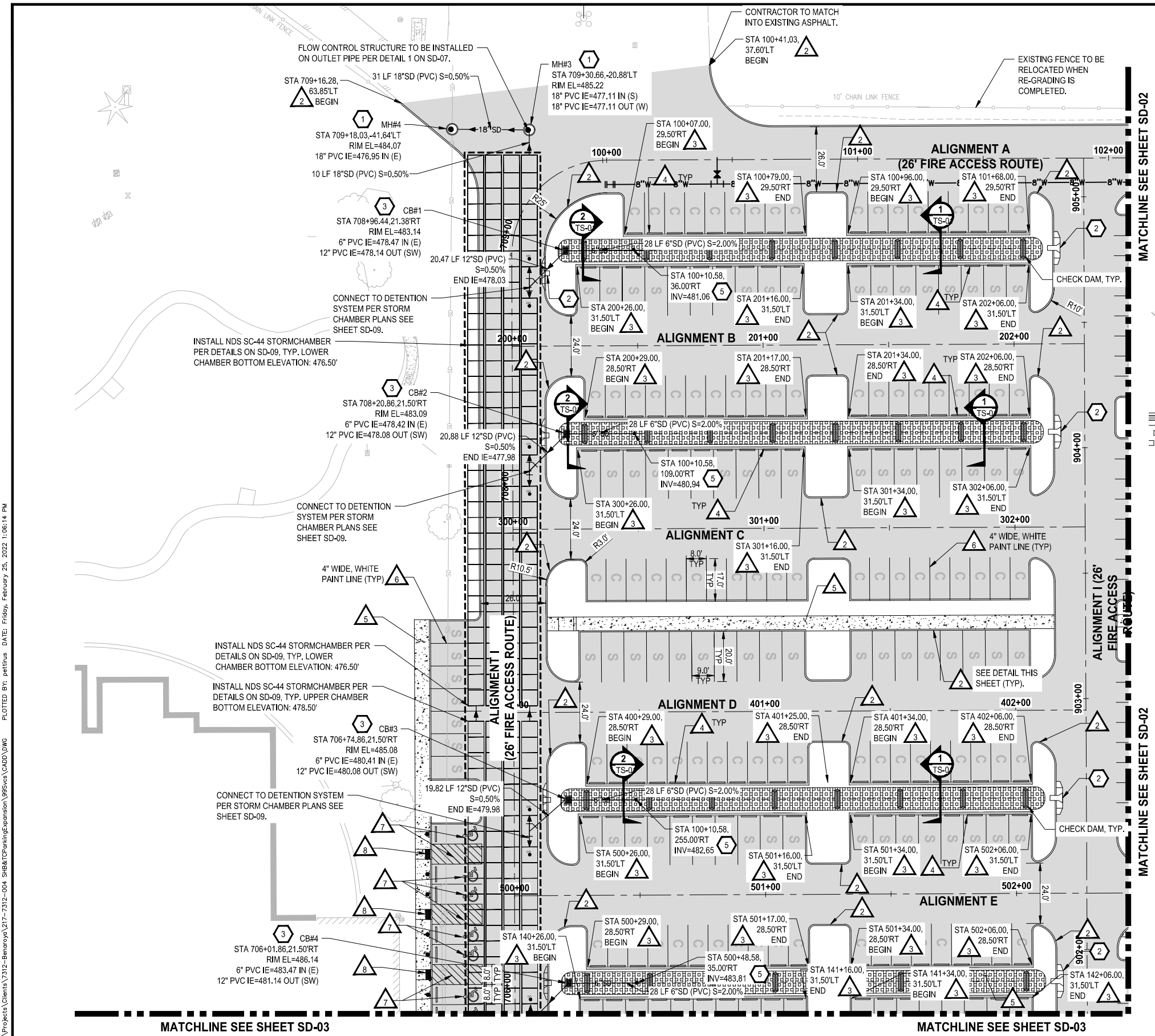

LAYOUT: SD-01
 PATH: U:\VSD\Projects\Clients\217-7312-004_SHB&CParkingExpansion\995\cs\A000\DWG
 PLOTTED BY: patinus DATE: Friday, February 25, 2022 1:06:14 PM

NO.	REVISIONS	DATE	BY	DESIGNED WZG

ONE INCH AT FULL SCALE. IF NOT, SCALE ACCORDINGLY.
 FILE NAME: 04-P50731200C-SD-HS
 JOB NO: 217-7312-004
 DATE: MARCH 2022

Parametrix
 ENGINEERING, PLANNING, ENVIRONMENTAL SCIENCES
 1019 39TH AVENUE SE, SUITE 100 | PUYALLUP, WA 98374
 P 253.604.6600
 WWW.PARAMETRIX.COM

PROJECT NAME
SOUTH HILL BUSINESS & TECHNOLOGY CENTER PARKING EXPANSION
 PUYALLUP, WA

HARDSCAPE & STORM DRAINAGE PLAN

DRAWING NO.
SD-01
 20 OF 58

APPROVED
 BY: CITY OF PUYALLUP
 ENGINEERING DEPARTMENT
 DATE: _____
 NOTE:
 This approval is void after 1 year from approval date. The City will not be responsible for errors and/or omissions on these plans.
 Field conditions may dictate changes to these plans as determined by the City Engineer.

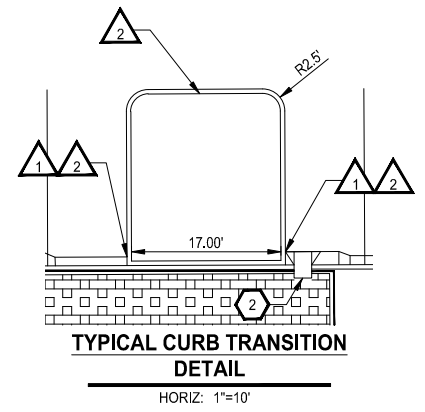
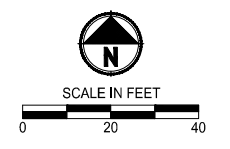

- LEGEND:**
- PROPERTY LINE
 - ROADWAY CENTERLINE
 - DEPRESSED CURB PER WSDOT STD PLAN F-10.12-04
 - CURB AND GUTTER PER WSDOT STD PLAN F-10.12-04
 - CONCRETE WALL
 - ASPHALT SURFACE
 - CEMENT CONCRETE SIDEWALK
 - BIORETENTION SOIL MEDIA PER SWMM BMP T7.30
 - SD --- STORM DRAINAGE PIPE (SIZE PER PLAN)
 - CATCH BASIN (TYPE PER PLAN)
 - STORM SEWER MANHOLE
 - C --- COMPACT PARKING STALL 8'x17'
 - S --- STANDARD PARKING STALL 9'x20'
 - EV --- STANDARD PARKING STALL 9'x20' WITH ELECTRIC VEHICLE CHARGING STATION

- GENERAL NOTES:**
- CONTRACTOR SHALL FURNISH AND INSTALL ALL MATERIALS AND EQUIPMENT NECESSARY TO COMPLETE THIS WORK.
 - ALL STORM DRAINAGE STRUCTURES CALL OUT TO CENTER OF STRUCTURE.
 - PIPE LENGTHS ARE FOR CALCULATION PURPOSES ONLY. BID QUANTITIES SHALL BE CALCULATED AS REQUIRED.

- ROADWAY CONSTRUCTION NOTES:**
- INSTALL CURB AND GUTTER, SEE CITY OF PUYALLUP STANDARD NO. 01.02.09 ON SHEET SD-06.
 - INSTALL TRAFFIC CURB, SEE WSDOT STANDARD PLAN F-10.12-04 ON SHEET SD-06.
 - INSTALL 1' WIDE DEPRESSED CURB, SEE WSDOT STANDARD PLAN F-10.12-04 ON SHEET SD-06.
 - INSTALL WHEEL STOP, SEE WSDOT STANDARD PLAN M-17.10-22 ON SHEET SD-06.
 - INSTALL SIDEWALK, SEE CITY OF PUYALLUP STANDARD NO. 01.02.01 ON SHEET SD-07.
 - INSTALL PARKING STALL PAINT MARKINGS, SEE WSDOT STANDARD PLAN M-17.10-02 ON SHEET SD-06.
 - INSTALL COMPLETE ADA PARKING STALLS CHANNELIZATION AND SIGNS, SEE WSDOT STANDARD PLAN M-17.10-02 ON SHEET SD-06. ALL SLOPES SHALL BE LESS THAN 2% IN ALL DIRECTIONS.
 - INSTALL CEMENT CONCRETE PARALLEL CURB RAMP, SEE WSDOT STANDARD PLAN F-40.12-03 ON SHEET SD-06.
 - CURB AND GUTTER TO CONTINUE BEHIND TRAFFIC CURB OF LANDSCAPE ISLAND.
 - INSTALL ZURN P12-PGR ANTI-SLIP ADA GRATE OR APPROVED EQUIVALENT PER DETAIL ON SD-07.

- BIORETENTION NOTES**
- THE BIORETENTION SOIL MIX SUPPLIER SHALL CERTIFY IN WRITING THAT THE BIORETENTION SOIL MIX COMPLIES WITH THE PROCESSES, TESTING, AND STANDARDS SPECIFIED BY THE 2012/2014 ECOLOGY MANUAL BIORETENTION SOIL MEDIA SPECIFICATION, BMP 7.30
 - AT THE COMPLETION OF THE BIORETENTION CELLS CONSTRUCTION, THE ENGINEER-OF-RECORD SHALL PROVIDE A WRITTEN STATEMENT TO THE CITY OF PUYALLUP THAT THE BIORETENTION CELLS WERE BUILT PER THE APPROVED DESIGN.

- STORM DRAINAGE CONSTRUCTION NOTES:**
- INSTALL STORM SEWER MANHOLE, SEE CITY OF PUYALLUP STANDARD NO. 02.01.01 ON SHEET SD-07.
 - INSTALL CONCRETE CURB INLET AND CONCRETE SPLASH PAD PER DETAIL 1 ON SD-06.
 - INSTALL CATCH BASIN TYPE 1, SEE CITY OF PUYALLUP STANDARD NO. 02.01.03 ON SHEET SD-07.
 - INSTALL CATCH BASIN TYPE II WITH BIORETENTION OVERFLOW OUTLET STRUCTURE, SEE CITY OF PUYALLUP STANDARD NO. 02.01.04 ON SHEET SD-07 AND NO.02.07.03 ON SD-07.
 - INSTALL STORM DRAIN CLEAN OUT.

NOTE: SYMBOLS NOT TO SCALE **100% REVIEW SUBMITTAL**

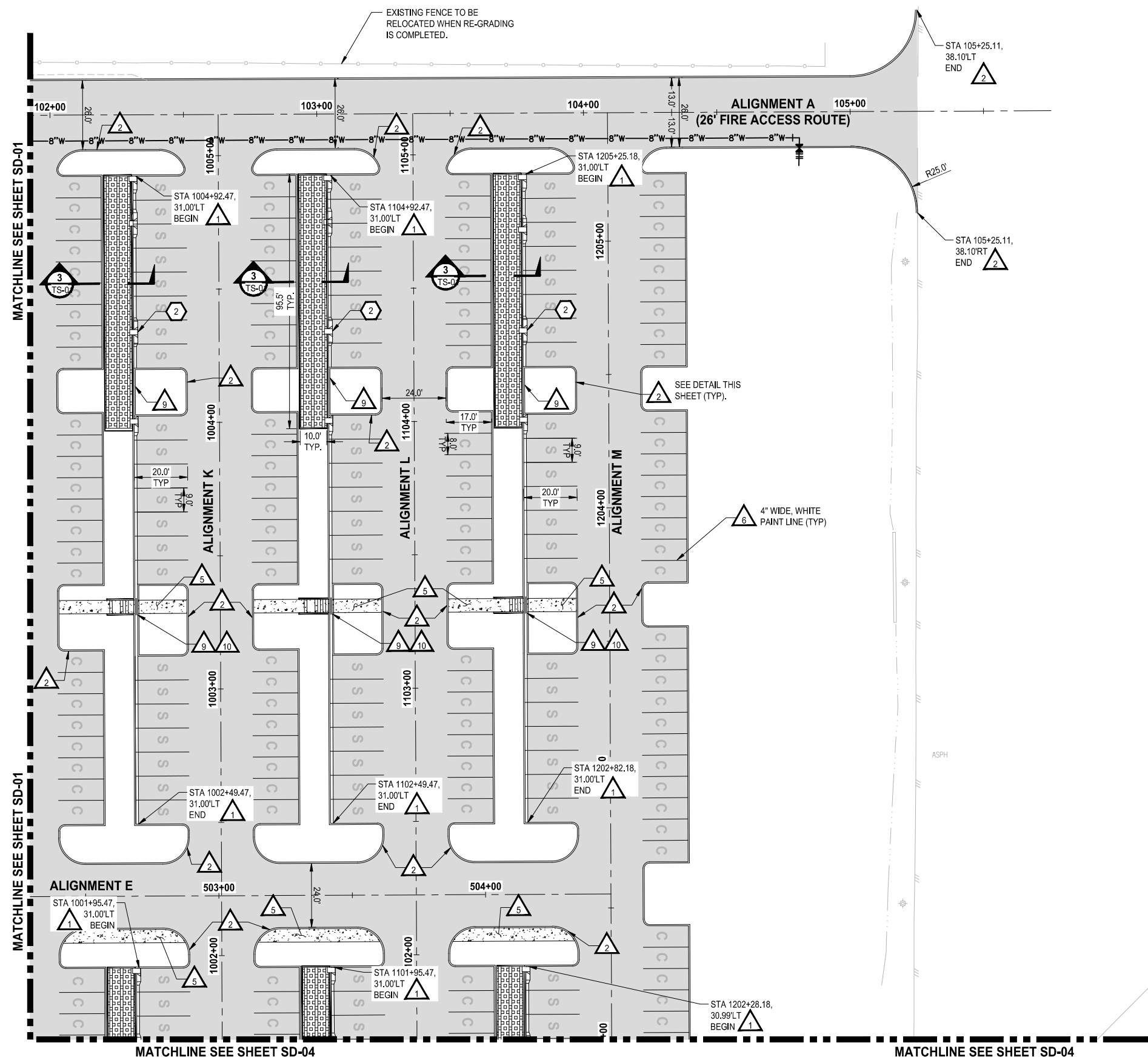

LAYOUT: SD-02
 PATH: u:\P50\Projects\Clients\312-Benaroya\217-7312-004-SHB&TCParkingExpansion\995\ea\c\00\DWG
 PLOTTED BY: patitus DATE: Friday, February 25, 2022 1:06:23 PM

NO.	REVISIONS	DATE	BY	DESIGNED WZG

ONE INCH AT FULL SCALE.
 IF NOT, SCALE ACCORDINGLY
 FILE NAME
 04-P50731200C-SD-HS
 JOB No.
 217-7312-004
 DATE
 MARCH 2022



PROJECT NAME
SOUTH HILL BUSINESS & TECHNOLOGY CENTER PARKING EXPANSION
 PUYALLUP, WA

HARDSCAPE & STORM DRAINAGE PLAN

DRAWING NO.
21 OF 58
SD-02

APPROVED
 BY: CITY OF PUYALLUP
 ENGINEERING DEPARTMENT
 DATE: _____
 NOTE:
 This approval is void after 1 year from approval date. The City will not be responsible for errors and/or omissions on these plans.
 Field conditions may dictate changes to these plans as determined by the City Engineer.

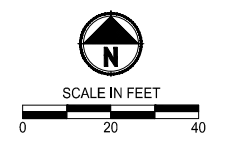

- LEGEND:**
- PROPERTY LINE
 - ROADWAY CENTERLINE
 - DEPRESSED CURB PER WSDOT STD PLAN F-10.12-04
 - CURB AND GUTTER PER WSDOT STD PLAN F-10.12-04
 - CONCRETE WALL
 - ASPHALT SURFACE
 - CEMENT CONCRETE SIDEWALK
 - BIORETENTION SOIL MEDIA PER SWMM BMP T7.30
 - SD --- STORM DRAINAGE PIPE (SIZE PER PLAN)
 - CATCH BASIN (TYPE PER PLAN)
 - STORM SEWER MANHOLE
 - C --- COMPACT PARKING STALL 8'x17'
 - S --- STANDARD PARKING STALL 9'x20'
 - EV --- STANDARD PARKING STALL 9'x20' WITH ELECTRIC VEHICLE CHARGING STATION

- GENERAL NOTES:**
- CONTRACTOR SHALL FURNISH AND INSTALL ALL MATERIALS AND EQUIPMENT NECESSARY TO COMPLETE THIS WORK.
 - ALL STORM DRAINAGE STRUCTURES CALL OUT TO CENTER OF STRUCTURE.
 - PIPE LENGTHS ARE FOR CALCULATION PURPOSES ONLY. BID QUANTITIES SHALL BE CALCULATED AS REQUIRED.

- ROADWAY CONSTRUCTION NOTES:**
- INSTALL CURB AND GUTTER, SEE CITY OF PUYALLUP STANDARD NO. 01.02.09 ON SHEET SD-06.
 - INSTALL TRAFFIC CURB, SEE WSDOT STANDARD PLAN F-10.12-04 ON SHEET SD-06.
 - INSTALL 1' WIDE DEPRESSED CURB, SEE WSDOT STANDARD PLAN F-10.12-04 ON SHEET SD-06.
 - INSTALL WHEEL STOP, SEE WSDOT STANDARD PLAN M-17.10-22 ON SHEET SD-06.
 - INSTALL SIDEWALK, SEE CITY OF PUYALLUP STANDARD NO. 01.02.01 ON SHEET SD-07.
 - INSTALL PARKING STALL PAINT MARKINGS, SEE WSDOT STANDARD PLAN M-17.10-02 ON SHEET SD-06.
 - INSTALL COMPLETE ADA PARKING STALLS CHANNELIZATION AND SIGNS, SEE WSDOT STANDARD PLAN M-17.10-02 ON SHEET SD-06. ALL SLOPES SHALL BE LESS THAN 2% IN ALL DIRECTIONS.
 - INSTALL CEMENT CONCRETE PARALLEL CURB RAMP, SEE WSDOT STANDARD PLAN F-40.12-03 ON SHEET SD-06.
 - CURB AND GUTTER TO CONTINUE BEHIND TRAFFIC CURB OF LANDSCAPE ISLAND.
 - INSTALL ZURN P12-PGR ANTI-SLIP ADA GRATE OR APPROVED EQUIVALENT PER DETAIL ON SD-07.

- STORM DRAINAGE CONSTRUCTION NOTES:**
- INSTALL STORM SEWER MANHOLE, SEE CITY OF PUYALLUP STANDARD NO. 02.01.01 ON SHEET SD-07.
 - INSTALL CONCRETE CURB INLET AND CONCRETE SPLASH PAD PER DETAIL 1 ON SD-06.
 - INSTALL CATCH BASIN TYPE 1, SEE CITY OF PUYALLUP STANDARD NO. 02.01.03 ON SHEET SD-07.
 - INSTALL CATCH BASIN TYPE II WITH BIORETENTION OVERFLOW OUTLET STRUCTURE, SEE CITY OF PUYALLUP STANDARD NO. 02.01.04 ON SHEET SD-07 AND NO.02.07.03 ON SD-07.
 - INSTALL STORM DRAIN CLEAN OUT.

NOTE: SYMBOLS NOT TO SCALE **100% REVIEW SUBMITTAL**

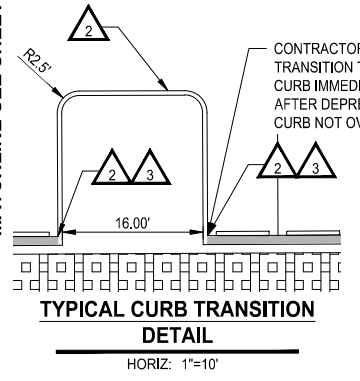

HORIZ: 1"=10'

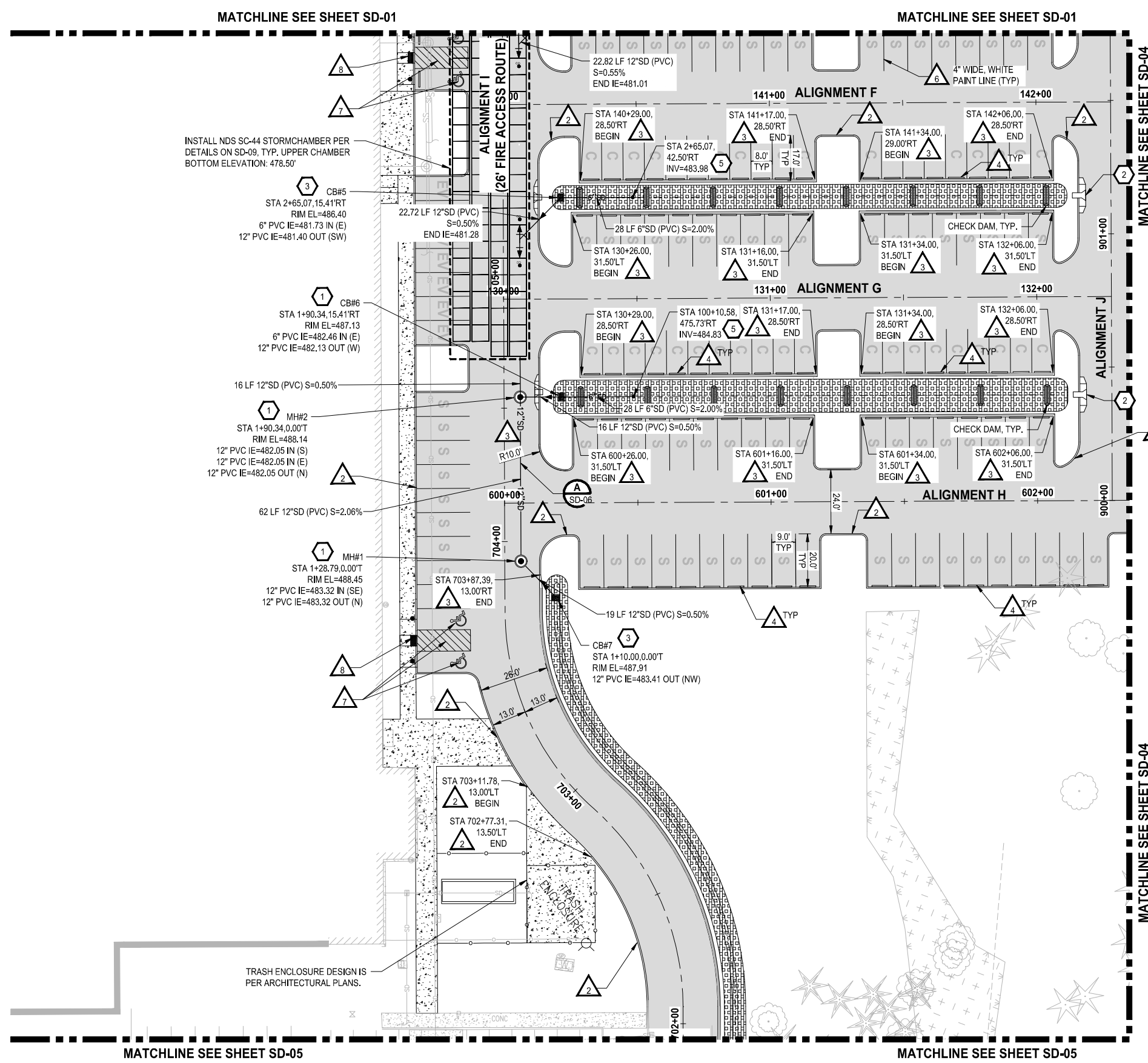

- BIORETENTION NOTES**
- THE BIORETENTION SOIL MIX SUPPLIER SHALL CERTIFY IN WRITING THAT THE BIORETENTION SOIL MIX COMPLIES WITH THE PROCESSES, TESTING, AND STANDARDS SPECIFIED BY THE 2012/2014 ECOLOGY MANUAL BIORETENTION SOIL MEDIA SPECIFICATION, BMP 7.30
 - AT THE COMPLETION OF THE BIORETENTION CELLS CONSTRUCTION, THE ENGINEER-OF-RECORD SHALL PROVIDE A WRITTEN STATEMENT TO THE CITY OF PUYALLUP THAT THE BIORETENTION CELLS WERE BUILT PER THE APPROVED DESIGN.

LAYOUT: SD-03
 PATH: U:\P50\Projects\Clients\312-Benaroya\217-7312-004-SHB&TCParkingExpansion\995\rev\A\00\DWG
 PLOTTED BY: patitus DATE: Friday, February 25, 2022 1:06:31 PM

NO.	REVISIONS	DATE	BY	DESIGNED WZG

ONE INCH AT FULL SCALE. IF NOT, SCALE ACCORDINGLY.
 FILE NAME: 04-P50731200C-SD-HS
 JOB No: 217-7312-004
 DATE: MARCH 2022

Parametrix
 ENGINEERING, PLANNING, ENVIRONMENTAL SCIENCES
 1019 39TH AVENUE SE, SUITE 100 | PUYALLUP, WA 98374
 P 253.604.6600
 WWW.PARAMETRIX.COM

PROJECT NAME
SOUTH HILL BUSINESS & TECHNOLOGY CENTER PARKING EXPANSION
 PUYALLUP, WA

HARDSCAPE & STORM DRAINAGE PLAN

DRAWING NO.
SD-03
 22 OF 58

APPROVED

BY: CITY OF PUYALLUP
ENGINEERING DEPARTMENT

DATE:

NOTE:
This approval is void after 1 year from approval date. The City will not be responsible for errors and/or omissions on these plans.

Field conditions may dictate changes to these plans as determined by the City Engineer.

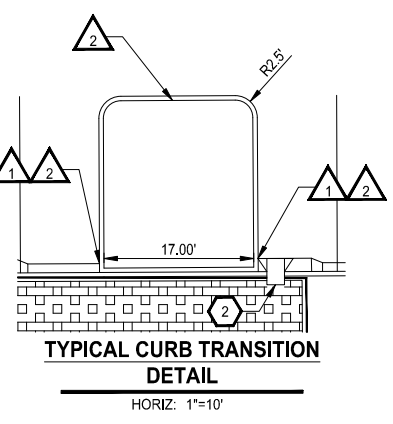
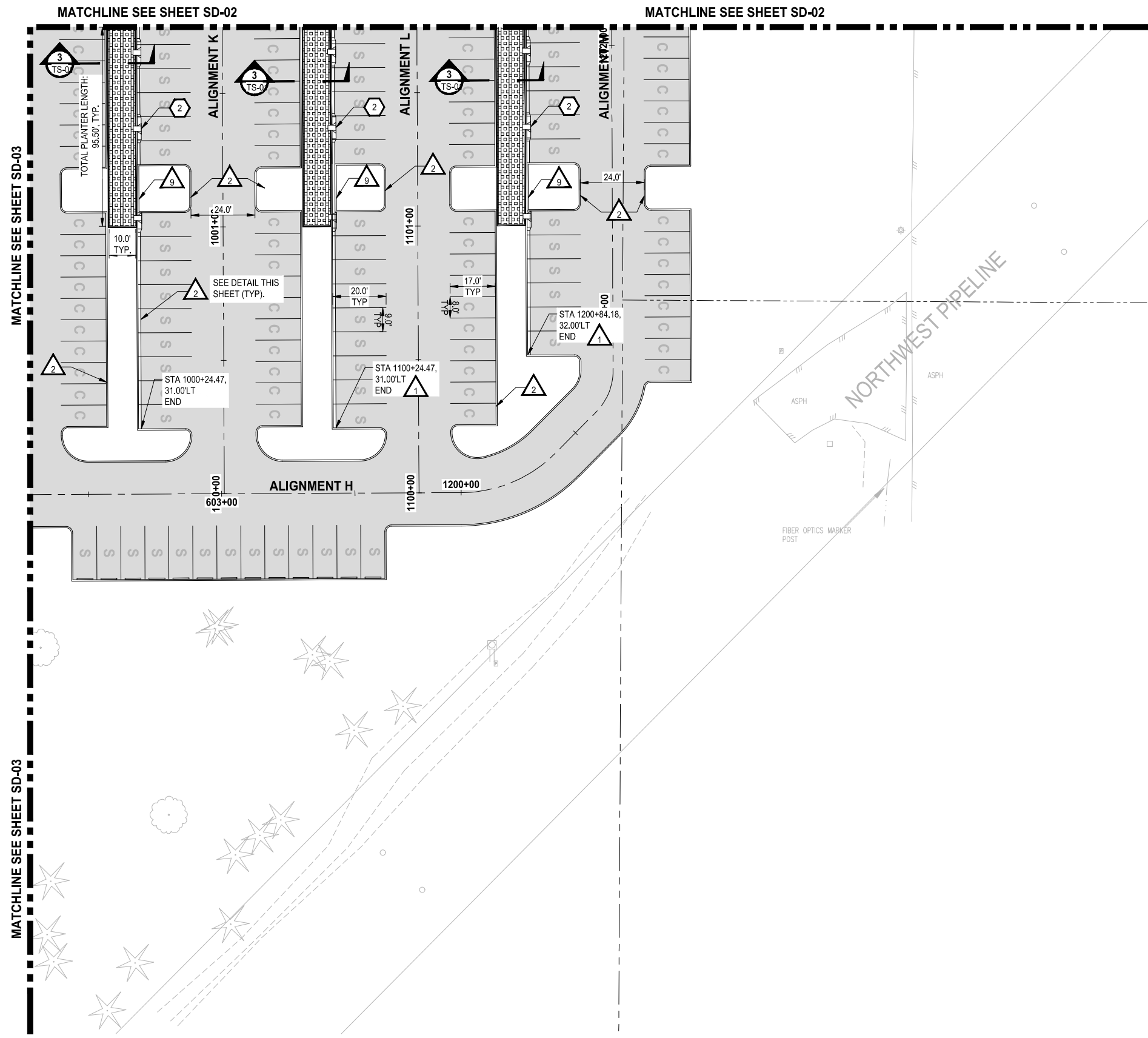
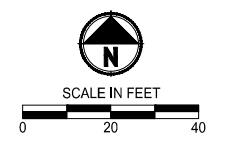

LEGEND:

- PROPERTY LINE
- ROADWAY CENTERLINE
- DEPRESSED CURB PER WSDOT STD PLAN F-10.12-04
- CURB AND GUTTER PER WSDOT STD PLAN F-10.12-04
- CONCRETE WALL
- ASPHALT SURFACE
- CEMENT CONCRETE SIDEWALK
- BIORETENTION SOIL MEDIA PER SWMM BMP T7.30
- STORM DRAINAGE PIPE (SIZE PER PLAN)
- CATCH BASIN (TYPE PER PLAN)
- STORM SEWER MANHOLE
- COMPACT PARKING STALL 8'x17'
- STANDARD PARKING STALL 9'x20'
- STANDARD PARKING STALL 9'x20' WITH ELECTRIC VEHICLE CHARGING STATION

- GENERAL NOTES:**
- CONTRACTOR SHALL FURNISH AND INSTALL ALL MATERIALS AND EQUIPMENT NECESSARY TO COMPLETE THIS WORK.
 - ALL STORM DRAINAGE STRUCTURES CALL OUT TO CENTER OF STRUCTURE.
 - PIPE LENGTHS ARE FOR CALCULATION PURPOSES ONLY. BID QUANTITIES SHALL BE CALCULATED AS REQUIRED.

- ROADWAY CONSTRUCTION NOTES:**
- 1. INSTALL CURB AND GUTTER, SEE CITY OF PUYALLUP STANDARD NO. 01.02.09 ON SHEET SD-06.
 - 2. INSTALL TRAFFIC CURB, SEE WSDOT STANDARD PLAN F-10.12-04 ON SHEET SD-06.
 - 3. INSTALL 1' WIDE DEPRESSED CURB, SEE WSDOT STANDARD PLAN F-10.12-04 ON SHEET SD-06.
 - 4. INSTALL WHEEL STOP, SEE WSDOT STANDARD PLAN M-17.10-22 ON SHEET SD-06.
 - 5. INSTALL SIDEWALK, SEE CITY OF PUYALLUP STANDARD NO. 01.02.01 ON SHEET SD-07.
 - 6. INSTALL PARKING STALL PAINT MARKINGS, SEE WSDOT STANDARD PLAN M-17.10-02 ON SHEET SD-06.
 - 7. INSTALL COMPLETE ADA PARKING STALLS CHANNELIZATION AND SIGNS, SEE WSDOT STANDARD PLAN M-17.10-02 ON SHEET SD-06. ALL SLOPES SHALL BE LESS THAN 2% IN ALL DIRECTIONS.
 - 8. INSTALL CEMENT CONCRETE PARALLEL CURB RAMP, SEE WSDOT STANDARD PLAN F-40.12-03 ON SHEET SD-06.
 - 9. CURB AND GUTTER TO CONTINUE BEHIND TRAFFIC CURB OF LANDSCAPE ISLAND.
 - 10. INSTALL ZURN P12-PGR ANTI-SLIP ADA GRATE OR APPROVED EQUIVALENT PER DETAIL ON SD-07.

- BIORETENTION NOTES**
- THE BIORETENTION SOIL MIX SUPPLIER SHALL CERTIFY IN WRITING THAT THE BIORETENTION SOIL MIX COMPLIES WITH THE PROCESSES, TESTING, AND STANDARDS SPECIFIED BY THE 2012/2014 ECOLOGY MANUAL BIORETENTION SOIL MEDIA SPECIFICATION, BMP 7.30
 - AT THE COMPLETION OF THE BIORETENTION CELLS CONSTRUCTION, THE ENGINEER-OF-RECORD SHALL PROVIDE A WRITTEN STATEMENT TO THE CITY OF PUYALLUP THAT THE BIORETENTION CELLS WERE BUILT PER THE APPROVED DESIGN.

- STORM DRAINAGE CONSTRUCTION NOTES:**
- 1. INSTALL STORM SEWER MANHOLE, SEE CITY OF PUYALLUP STANDARD NO. 02.01.01 ON SHEET SD-07.
 - 2. INSTALL CONCRETE CURB INLET AND CONCRETE SPLASH PAD PER DETAIL 1 ON SD-06.
 - 3. INSTALL CATCH BASIN TYPE 1, SEE CITY OF PUYALLUP STANDARD NO. 02.01.03 ON SHEET SD-07.
 - 4. INSTALL CATCH BASIN TYPE II WITH BIORETENTION OVERFLOW OUTLET STRUCTURE, SEE CITY OF PUYALLUP STANDARD NO. 02.01.04 ON SHEET SD-07 AND NO.02.07.03 ON SD-07.
 - 5. INSTALL STORM DRAIN CLEAN OUT.

NOTE: SYMBOLS NOT TO SCALE

100% REVIEW SUBMITTAL

LAYOUT: SD-04 PATH: u:\p50\Projects\Clients\312-Beneroy\312-7312-004-SHB&TCParkingExpansion\995\see\CAD\DWG PLOTTED BY: petrus DATE: Friday, February 25, 2022 1:06:38 PM

NO.	REVISIONS	DATE	BY	DESIGNED	WZG

ONE INCH AT FULL SCALE. IF NOT, SCALE ACCORDINGLY.

FILE NAME: 04-P50731200C-SD-HS
 JOB No: 217-7312-004
 DATE: MARCH 2022



PROJECT NAME
SOUTH HILL BUSINESS & TECHNOLOGY CENTER PARKING EXPANSION
PUYALLUP, WA

HARDSCAPE & STORM DRAINAGE PLAN

DRAWING NO. 23 OF 58
SD-04

LAYOUT: SD-05
 PATH: u:\p50\Projects\Clients\312-Benaroya\217-7312-004-SHB&TCParkingExpansion\995\ex\CAD\DWG
 PLOTTED BY: patitus DATE: Friday, February 25, 2022 1:06:47 PM

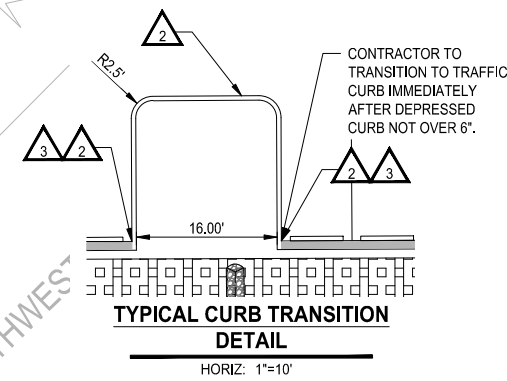
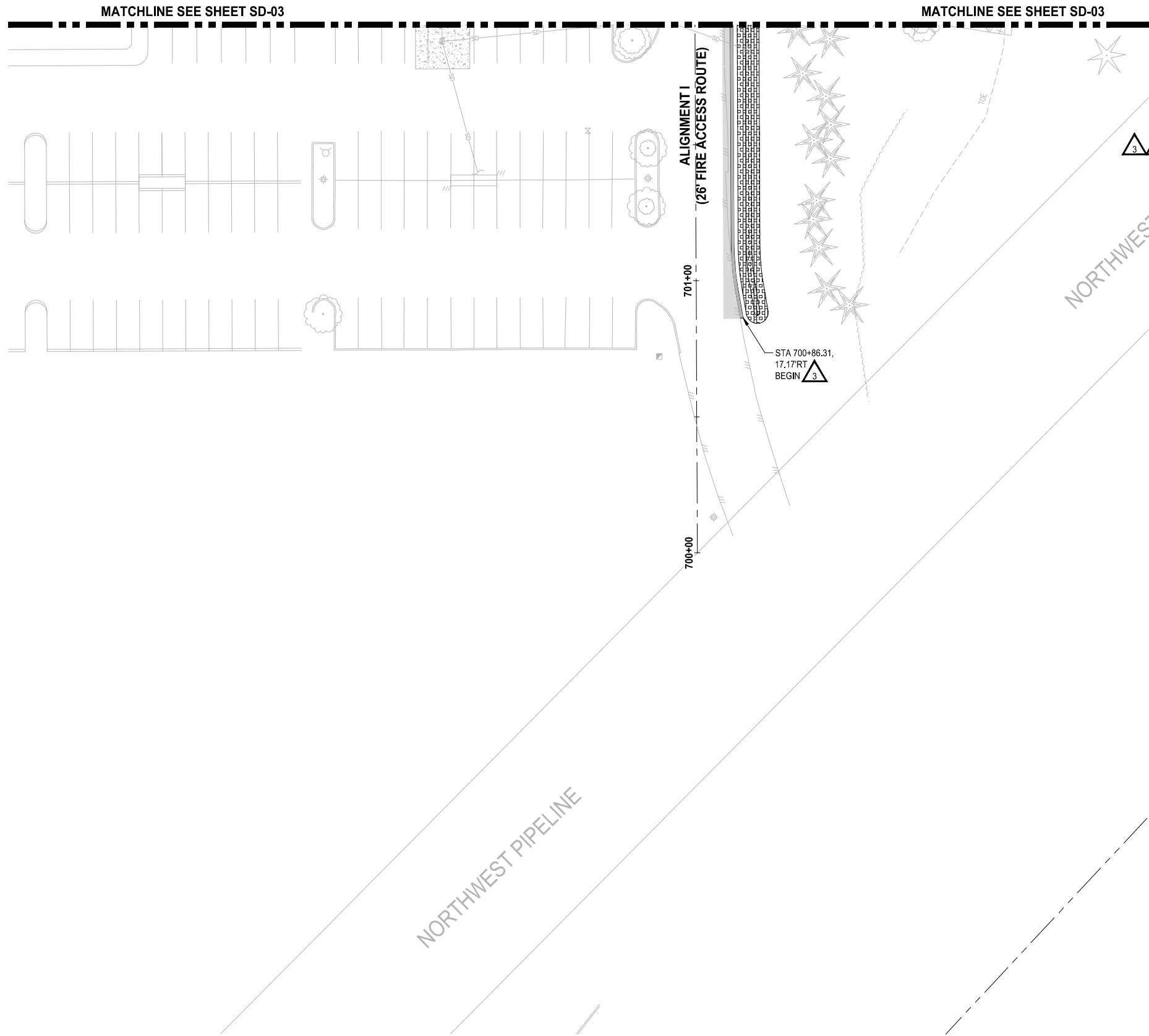

SCALE IN FEET
 0 20 40

APPROVED
 BY: CITY OF PUYALLUP
 ENGINEERING DEPARTMENT
 DATE: _____
 NOTE:
 This approval is void after 1 year from approval date. The City will not be responsible for errors and/or omissions on these plans.
 Field conditions may dictate changes to these plans as determined by the City Engineer.

- LEGEND:**
- PROPERTY LINE
 - ROADWAY CENTERLINE
 - DEPRESSED CURB PER WSDOT STD PLAN F-10.12-04
 - CURB AND GUTTER PER WSDOT STD PLAN F-10.12-04
 - CONCRETE WALL
 - ASPHALT SURFACE
 - CEMENT CONCRETE SIDEWALK
 - BIORETENTION SOIL MEDIA PER SWMM BMP T7.30
 - SD --- STORM DRAINAGE PIPE (SIZE PER PLAN)
 - --- CATCH BASIN (TYPE PER PLAN)
 - --- STORM SEWER MANHOLE
 - C | --- COMPACT PARKING STALL 8'x17'
 - S | --- STANDARD PARKING STALL 9'x20'
 - EV | --- STANDARD PARKING STALL 9'x20' WITH ELECTRIC VEHICLE CHARGING STATION

- GENERAL NOTES:**
- CONTRACTOR SHALL FURNISH AND INSTALL ALL MATERIALS AND EQUIPMENT NECESSARY TO COMPLETE THIS WORK.
 - ALL STORM DRAINAGE STRUCTURES CALL OUT TO CENTER OF STRUCTURE.
 - PIPE LENGTHS ARE FOR CALCULATION PURPOSES ONLY. BID QUANTITIES SHALL BE CALCULATED AS REQUIRED.

- ROADWAY CONSTRUCTION NOTES:**
- INSTALL CURB AND GUTTER, SEE CITY OF PUYALLUP STANDARD NO. 01.02.09 ON SHEET SD-06.
 - INSTALL TRAFFIC CURB, SEE WSDOT STANDARD PLAN F-10.12-04 ON SHEET SD-06.
 - INSTALL 1' WIDE DEPRESSED CURB, SEE WSDOT STANDARD PLAN F-10.12-04 ON SHEET SD-06.
 - INSTALL WHEEL STOP, SEE WSDOT STANDARD PLAN M-17.10-22 ON SHEET SD-06.
 - INSTALL SIDEWALK, SEE CITY OF PUYALLUP STANDARD NO. 01.02.01 ON SHEET SD-07.
 - INSTALL PARKING STALL PAINT MARKINGS, SEE WSDOT STANDARD PLAN M-17.10-02 ON SHEET SD-06.
 - INSTALL COMPLETE ADA PARKING STALLS CHANNELIZATION AND SIGNS, SEE WSDOT STANDARD PLAN M-17.10-02 ON SHEET SD-06. ALL SLOPES SHALL BE LESS THAN 2% IN ALL DIRECTIONS.
 - INSTALL CEMENT CONCRETE PARALLEL CURB RAMP, SEE WSDOT STANDARD PLAN F-40.12-03 ON SHEET SD-06.
 - CURB AND GUTTER TO CONTINUE BEHIND TRAFFIC CURB OF LANDSCAPE ISLAND.
 - INSTALL ZURN P12-PGR ANTI-SLIP ADA GRATE OR APPROVED EQUIVALENT PER DETAIL ON SD-07.

- BIORETENTION NOTES**
- THE BIORETENTION SOIL MIX SUPPLIER SHALL CERTIFY IN WRITING THAT THE BIORETENTION SOIL MIX COMPLIES WITH THE PROCESSES, TESTING, AND STANDARDS SPECIFIED BY THE 2012/2014 ECOLOGY MANUAL BIORETENTION SOIL MEDIA SPECIFICATION, BMP 7.30
 - AT THE COMPLETION OF THE BIORETENTION CELLS CONSTRUCTION, THE ENGINEER-OF-RECORD SHALL PROVIDE A WRITTEN STATEMENT TO THE CITY OF PUYALLUP THAT THE BIORETENTION CELLS WERE BUILT PER THE APPROVED DESIGN.

- STORM DRAINAGE CONSTRUCTION NOTES:**
- INSTALL STORM SEWER MANHOLE, SEE CITY OF PUYALLUP STANDARD NO. 02.01.01 ON SHEET SD-07.
 - INSTALL CONCRETE CURB INLET AND CONCRETE SPLASH PAD PER DETAIL 1 ON SD-06.
 - INSTALL CATCH BASIN TYPE 1, SEE CITY OF PUYALLUP STANDARD NO. 02.01.03 ON SHEET SD-07.
 - INSTALL CATCH BASIN TYPE II WITH BIORETENTION OVERFLOW OUTLET STRUCTURE, SEE CITY OF PUYALLUP STANDARD NO. 02.01.04 ON SHEET SD-07 AND NO.02.07.03 ON SD-07.
 - INSTALL STORM DRAIN CLEAN OUT.

NOTE: SYMBOLS NOT TO SCALE **100% REVIEW SUBMITTAL**

NO.	REVISIONS	DATE	BY	DESIGNED WZG

ONE INCH AT FULL SCALE.
 IF NOT, SCALE ACCORDINGLY
 FILE NAME
 04-P50731200C-SD-HS
 JOB No.
 217-7312-004
 DATE
 MARCH 2022

Parametrix
 ENGINEERING . PLANNING . ENVIRONMENTAL SCIENCES
 1019 39TH AVENUE SE, SUITE 100 | PUYALLUP, WA 98374
 P 253.604.6600
 WWW.PARAMETRIX.COM

PROJECT NAME
SOUTH HILL BUSINESS & TECHNOLOGY CENTER PARKING EXPANSION
 PUYALLUP, WA

HARDSCAPE & STORM DRAINAGE PLAN

DRAWING NO.
 24 OF 58
SD-05

APPROVED
 BY _____
 CITY OF PUYALLUP
 ENGINEERING DEPARTMENT
 DATE _____
 NOTE:
 This approval is void after
 1 year from approval date.
 The City will not be responsible
 for errors and/or omissions on
 these plans.
 Field conditions may dictate
 changes to these plans as
 determined by the City
 Engineer.

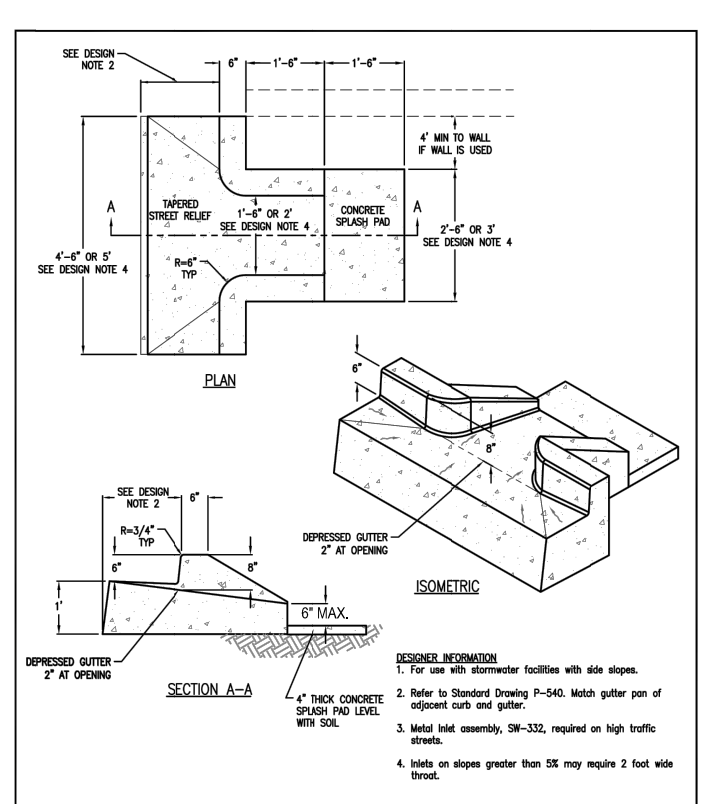
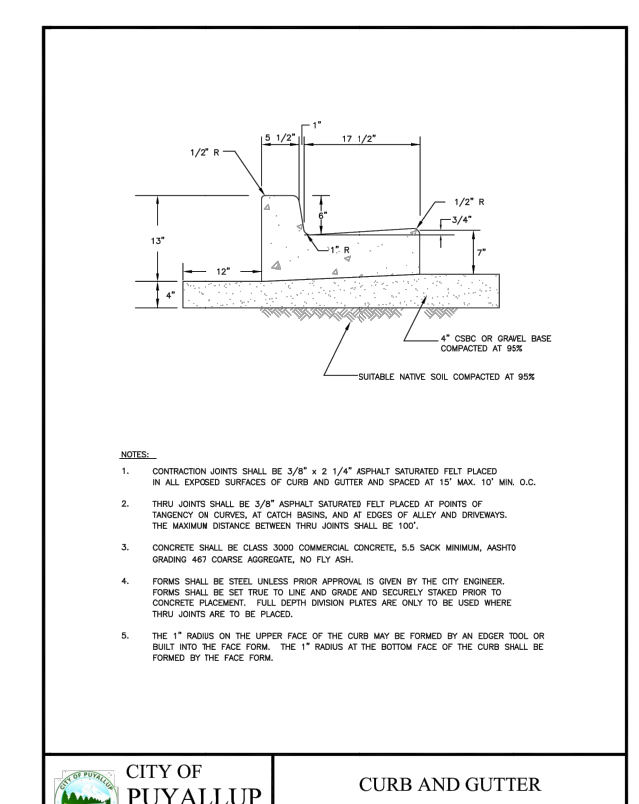
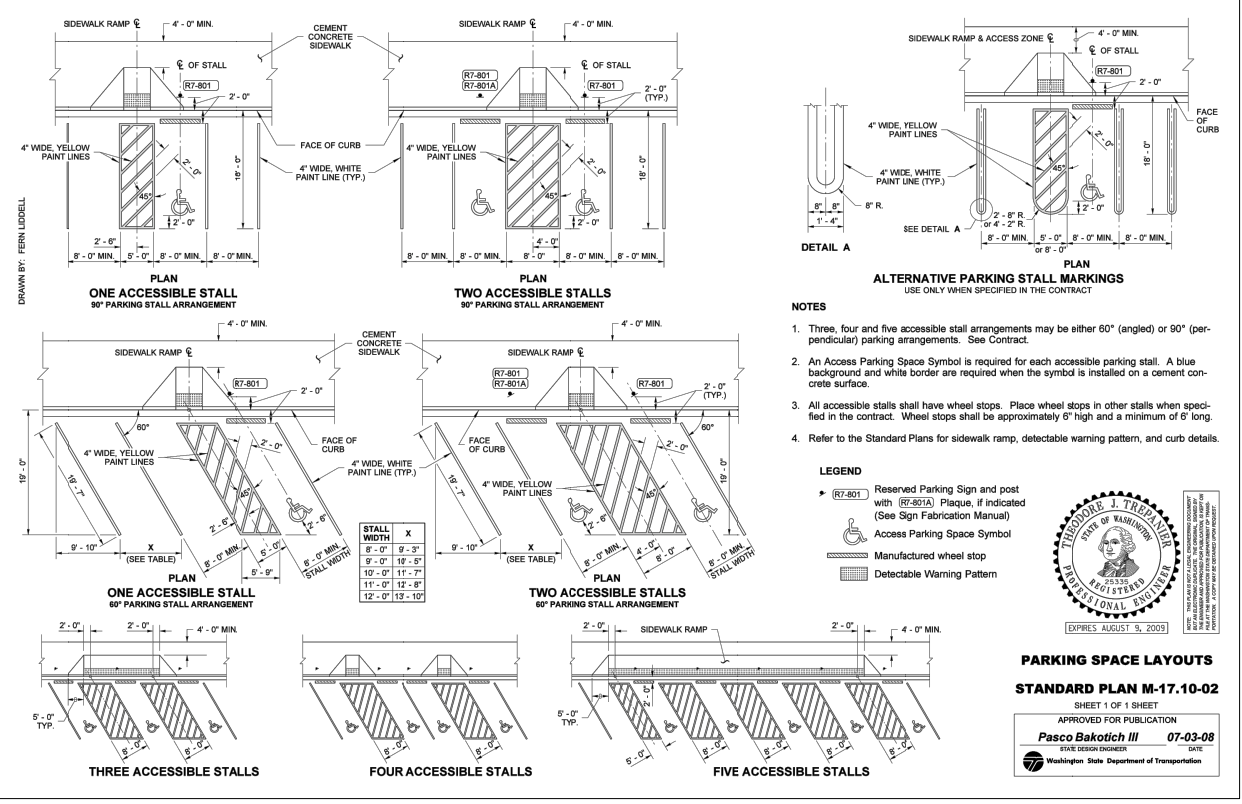
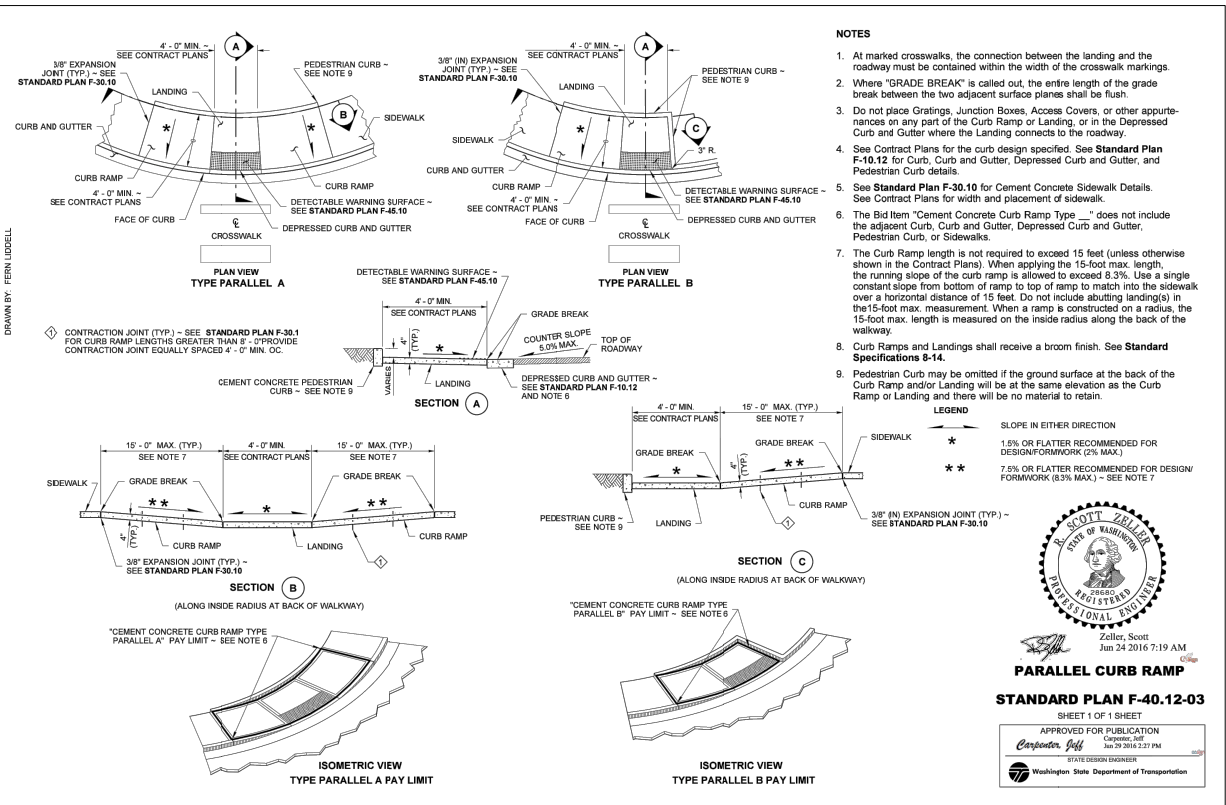
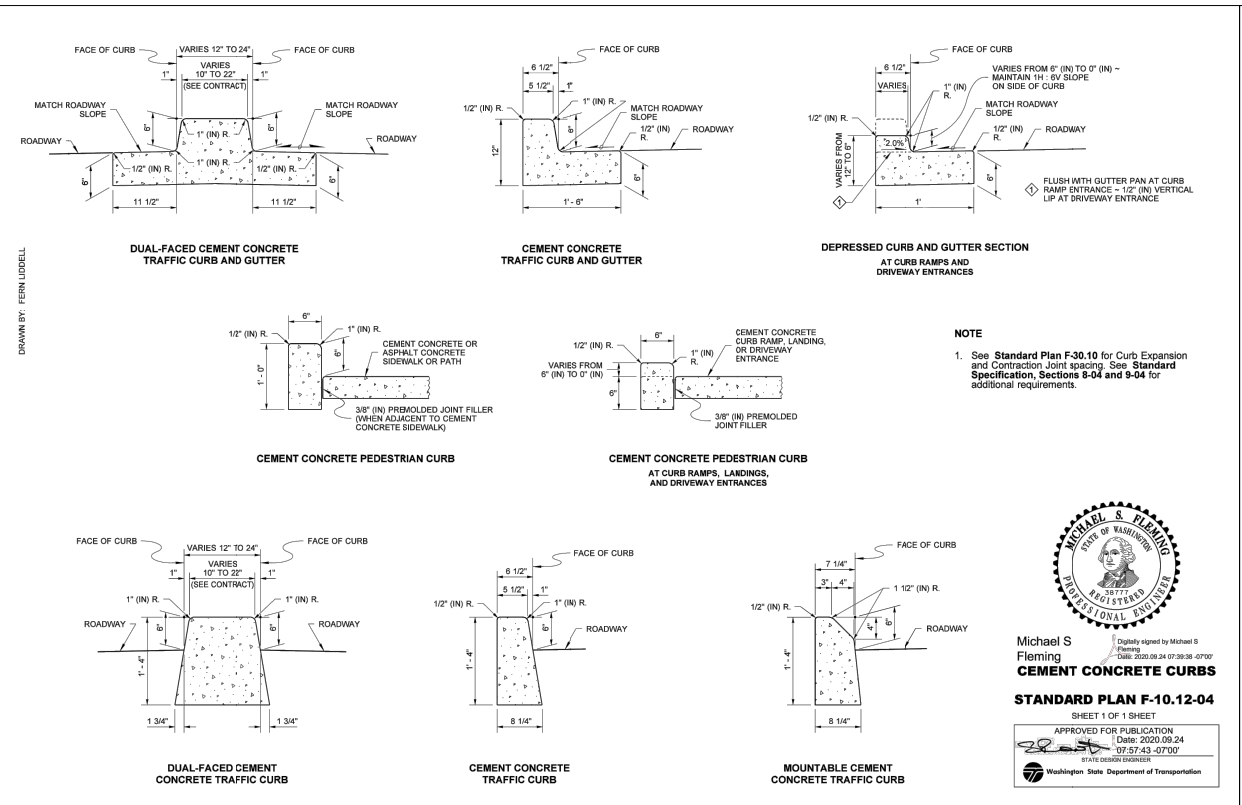

NOTE:
 SYMBOLS NOT TO SCALE

100% REVIEW SUBMITTAL

LAYOUT: 5D-06 PATH: u:\P50\Projects\Clients\312-Benaroya\217-7312-004-SHB&TCParkingExpansion\95\eca\CAD\DWG PLOTTED BY: peltius DATE: Friday, February 25, 2022 1:06:52 PM

REVISIONS	DATE	BY	DESIGNED WZG

ONE INCH AT FULL SCALE, IF NOT, SCALE ACCORDINGLY
 FILE NAME: 04-P50731200C-SD-HS
 CHECKED: DCS
 APPROVED: DCS
 DATE: MARCH 2022

Parametrix
 ENGINEERING, PLANNING, ENVIRONMENTAL SCIENCES
 1019 39TH AVENUE SE, SUITE 100 | PUYALLUP, WA 98374
 P 253.604.6600
 WWW.PARAMETRIX.COM

PROJECT NAME
SOUTH HILL BUSINESS & TECHNOLOGY CENTER PARKING EXPANSION
 PUYALLUP, WA

HARDSCAPE STANDARD DETAILS
SD-06

DRAWING NO.
 25 OF 58

STORM SEWER MANHOLE

NOTES:

- THE CONSTRUCTION AND INSTALLATION OF STORM SEWER MANHOLES SHALL CONFORM TO THE REQUIREMENTS OF WSDOT SPEC. SECTION 7-05 AND ASTM C 478.
- THE FACE OF NEAT LINE CUTS IN EXISTING ASPHALT PAVEMENT SHALL BE TACK COATED AND THE TOP OF THE JOINT SHALL BE SEALED WITH A HOT PAVING GRADE ASPHALT.
- PRECAST RISER SECTION OR PRECAST BASE WITH INTEGRAL RISER SHALL BE FURNISHED WITH CUTOUTS OR KNOCKOUTS WITH A MINIMUM WALL THICKNESS OF 2" THE SIZE OF THE KNOCKOUT SHALL BE EQUAL TO THE PIPE OUTER DIAMETER PLUS THE MANHOLE WALL THICKNESS. THE MAXIMUM HOLE SIZE IS 36" FOR A 48" MANHOLE, 42" FOR A 54" MANHOLE, 60" FOR A 72" MANHOLE, AND 84" FOR A 96" MANHOLE.
- A FLEXIBLE GASKETED JOINT SHALL BE INSTALLED WITHIN 12" OF EACH CONNECTION TO A MANHOLE. THE CONNECTION OF CONCRETE OR DUCTILE IRON PIPE TO A MANHOLE SHALL BE CEMENT MORTARED. DUCTILE IRON PIPE SHALL BE SEALED WITH MASTIC AT THE CONNECTION POINT PRIOR TO BEING MORTARED. THE CONNECTION OF PVC PIPE TO A MANHOLE SHALL UTILIZE A MANHOLE COUPLING (SAND COLLAR) WITH A RUBBER GASKET.
- THE MANHOLE COVER SHALL BE MARKED WITH "STORM" OR "DRAIN" IN 2 INCH RAISED LETTERS. MANHOLE RING AND COVER SHALL CONFORM TO CITY STANDARD DETAIL NO. 06.01.03.
- MANHOLE STEP AND LADDER SHALL CONFORM TO CITY STANDARD DETAILS NO. 06.01.04 AND 06.01.05.

CITY OF PUYALLUP DEVELOPMENT ENGINEERING and PUBLIC WORKS DEPARTMENTS	STORM SEWER MANHOLE		
DESIGNED BY: LINDA LARSON	CHECKED BY: LINDA LARSON	APPROVED BY: COLLEEN BARBER	DATE: 02.01.01

BIORETENTION OVERFLOW OUTLET STRUCTURE

NOTES:

- FRAME AND GRATE SHALL BE LOCKING AND GRATE SHALL BE BOLTED TO FRAME. FRAME SHALL CONFORM TO WSDOT STANDARD PLAN B-30.10-01.
- OVERFLOW STRUCTURE SHALL BE LOCATED WITHIN 10 FEET OF ROAD EDGE FOR MAINTENANCE ACCESS, UNLESS APPROVED OTHERWISE. OVERFLOW STRUCTURE MAY BE LOCATED IN SIDE SLOPES.
- FRAME AND GRATE TO CONFORM TO WSDOT STANDARD SPECIFICATIONS 9-05.15(2).
- PLANT SPACING WITHIN FACILITY TO ALLOW MAINTENANCE ACCESS TO STRUCTURE.

CITY OF PUYALLUP OFFICE THE CITY ENGINEER	BIORETENTION OVERFLOW OUTLET STRUCTURE		
DESIGNED BY: LINDA LARSON	CHECKED BY: LINDA LARSON	APPROVED BY: COLLEEN BARBER	DATE: 02.07.03

SIDEWALK WITHOUT PLANTING STRIP

NOTES:

- CONTRACTION JOINTS SHALL BE 3/8" x 1 1/2" ASPHALT SATURATED FELT PLACED AT 15' O.C.
- THRU JOINTS SHALL BE 3/8" x 4" ASPHALT SATURATED FELT PLACED AT DRIVEWAYS, ALLEY RETURNS AND WHEELCHAIR RAMPS AND RAMP.
- V-GROOVEMARKS SHALL BE 1/8" DEEP AND 1/4" WIDE PLACED AT 5' O.C. FOR 5' SIDEWALKS AND 7.5' O.C. FOR 8' SIDEWALKS.
- ALL JOINTS SHALL BE CLEAN AND EDGED TO A 1/4" RADIUS. JOINTS SHALL BE FLUSH WITH THE FINISHED SURFACE.
- ALL UTILITY POLES AND STREET SIGN POSTS IN SIDEWALK AREA NOT REQUIRED TO BE RELOCATED SHALL HAVE A SQUARE SECTION OF CONCRETE SURROUNDED BY 3/8" EXPANSION JOINT MATERIAL AROUND THE POLE. THE JOINT SHALL BE NO CLOSER THAN 6" TO ANY SIDE OF THE POLE.
- FORMS SHALL BE EITHER WOOD OR STEEL AND SHALL MEET ALL REQUIREMENTS OF THESE SPECIFICATIONS.
- CONCRETE SHALL BE CLASS 3000 COMMERCIAL CONCRETE, 5.5 SACK MINIMUM, ASHTO GRADING 487 COARSE AGGREGATE, NO FLY ASH.
- SIDEWALK MINIMUM UNOBSTRUCTED CLEAR WIDTH SHALL BE 4', EXCLUSIVE OF THE WIDTH OF THE CURB.
- GRATINGS, ACCESS COVERS, JUNCTION BOXES, CABLE VAULTS, PULL BOXES AND OTHER APERTURES WITHIN THE SIDEWALK (RIGHT-OF-WAY) MUST HAVE SLIP RESISTANT SURFACE AND MATCH THE GRADE OF THE SIDEWALK.
- CURB RAMPS SHALL BE CONSTRUCTED AT INTERSECTIONS USING A DESIGN PREPARED BY A LICENSED PROFESSIONAL ENGINEER. WHEN A RAMP DESIGN FAILS TO MEET ALL APPLICABLE DESIGN STANDARDS, THE ENGINEER SHALL DOCUMENT WHY THE PROPOSED RAMP ACHIEVES DESIGN STANDARDS TO THE MAXIMUM EXTENT FEASIBLE.

CITY OF PUYALLUP DEVELOPMENT ENGINEERING and PUBLIC WORKS DEPARTMENTS	SIDEWALK WITHOUT PLANTING STRIP		
DESIGNED BY: LINDA LARSON	CHECKED BY: LINDA LARSON	APPROVED BY: COLLEEN BARBER	DATE: 01.02.01

P12-PGR

12 [305] Wide Galvanized Steel Raised Perforated Anti-Slip ADA Grate

PGR - Raised Perforated

Material:	Galvanized Steel
DIN Rating:	Class A
Weight:	7.0 lbs/ft [10 kg/m]
Open Area:	14.9 in ² /ft [315 cm ² /m]
ANSI Rating:	Light-Duty
ADA:	Yes
H-20:	No
FAA:	No

PGR GRATE ENGINEERING SPECIFICATION: The Zurn P12-PGR Galvanized Steel Raised Perforated Grate, is 11-3/8" [289mm] wide X 24" [610mm] long, weighing 7 lbs per linear foot [10kg/m]. The grate has an open area of 14.9 in² per linear foot [315cm²/m], DIN Rating of A, ANSI Rating of Light-Duty, and ADA Compliant. Galvanized steel conforms to ASTM A36. Galvanized Sheet conforms to ASTM Specification A653, Galvanized Coating designation G60, minimum spangle.

Zurn Industries, LLC | Light Commercial Plumbing Products
1801 Pittsburgh Avenue, Erie, PA U.S.A. 16502 • Ph. 855-663-9876, Fax 814-454-7859
In Canada | Zurn Industries Limited
2544 Napa Drive, Mississauga, Ontario L4V 1L2 • Ph. 905-405-8272, Fax 905-405-1292
www.zurn.com

Rev. AA
Date: 01/11/16
C.N. No. 133793
Form # FT649

Sheet 31 of 46

APPROVED

BY: _____
CITY OF PUYALLUP
ENGINEERING DEPARTMENT

DATE: _____

NOTE:
This approval is void after 1 year from approval date. The City will not be responsible for errors and/or omissions on these plans.
Field conditions may dictate changes to these plans as determined by the City Engineer.

CATCH BASIN FRAME AND GRATE/VANED GRATE

NOTES:

- MATERIAL SHALL CONFORM TO SECTION 9-05.15 "METAL CASTINGS" OF THE "STANDARD SPECIFICATIONS FOR ROAD, BRIDGE, AND MUNICIPAL CONSTRUCTION" PUBLISHED BY THE STATE DEPARTMENT OF TRANSPORTATION AND AMERICAN PUBLIC WORKS ASSOCIATION, WASHINGTON STATE CHAPTER.
- THE NAME OF THE MANUFACTURE AND DIRECTION OF FLOW SHALL BE EMBOSSED ON THE TOP SURFACE OF EACH GRATE. LETTERING TO BE RECESSED 1/16".
- THE MATERIAL USED FOR THE GRATE SHALL BE DESIGNATED BY EMBASSING EITHER DI (FOR DUCTILE IRON) OR CS (FOR CAST STEEL) NEAR THE NAME OF THE MANUFACTURER.
- DIMENSIONS SHALL HAVE A +/- 1/16" TOLERANCE, EXCEPT AS NOTED.
- EDGES SHALL HAVE 1/8" RADIUS.
- WELDING IS NOT PERMITTED.
- AS AN ALTERNATE, 8 PADS 1 1/2" X 3/4" X 1/8", INTEGRALLY CAST WITH THE GRATE, MAY BE USED.

CITY OF PUYALLUP DEVELOPMENT ENGINEERING and PUBLIC WORKS DEPARTMENTS	CATCH BASIN FRAME AND GRATE/VANED GRATE		
DESIGNED BY: LINDA LARSON	CHECKED BY: LINDA LARSON	APPROVED BY: COLLEEN BARBER	DATE: 02.01.05

FLOW CONTROL MANHOLE WITH CONE SECTION

CITY OF PUYALLUP DEVELOPMENT ENGINEERING and PUBLIC WORKS DEPARTMENTS	FLOW CONTROL MANHOLE WITH CONE SECTION		
DESIGNED BY: LINDA LARSON	CHECKED BY: LINDA LARSON	APPROVED BY: COLLEEN BARBER	DATE: 02.01.06

FLOW CONTROL STRUCTURE DETAIL

NO SCALE

CITY OF PUYALLUP DEVELOPMENT ENGINEERING and PUBLIC WORKS DEPARTMENTS	FLOW CONTROL STRUCTURE DETAIL		
DESIGNED BY: LINDA LARSON	CHECKED BY: LINDA LARSON	APPROVED BY: COLLEEN BARBER	DATE: 02.01.06

REVISIONS	DATE	BY	DESIGNED WZG

ONE INCH AT FULL SCALE. IF NOT, SCALE ACCORDINGLY.

FILE NAME: 04-P50731200C-SD-HS
JOB No: 217-7312-004
DATE: MARCH 2022

Parametrix
ENGINEERING, PLANNING, ENVIRONMENTAL SCIENCES

1019 39TH AVENUE SE, SUITE 100 | PUYALLUP, WA 98374
P 253.604.6600
WWW.PARAMETRIX.COM

PROJECT NAME
SOUTH HILL BUSINESS & TECHNOLOGY CENTER PARKING EXPANSION
PUYALLUP, WA

STORM DRAINAGE STANDARD DETAILS

DRAWING NO.
26 OF 58
SD-07

NOTE:
SYMBOLS NOT TO SCALE

100% REVIEW SUBMITTAL

LAYOUT: SB-07 PATH: U:\P507\Projects\Clients\217-7312-004-SHB&TCParkingExpansion\95\sec\CAD\DWG PLOTTED BY: peltius DATE: Friday, February 25, 2022 1:06:58 PM

LAYOUT: 5D-08
 PATH: u:\P50\Projects\Clients\312-Benaroya\217-7312-004-SHB&TCParkingExpansion\995\cadd\dwg
 PLOTTED BY: peltius DATE: Friday, February 25, 2022 1:07:04 PM

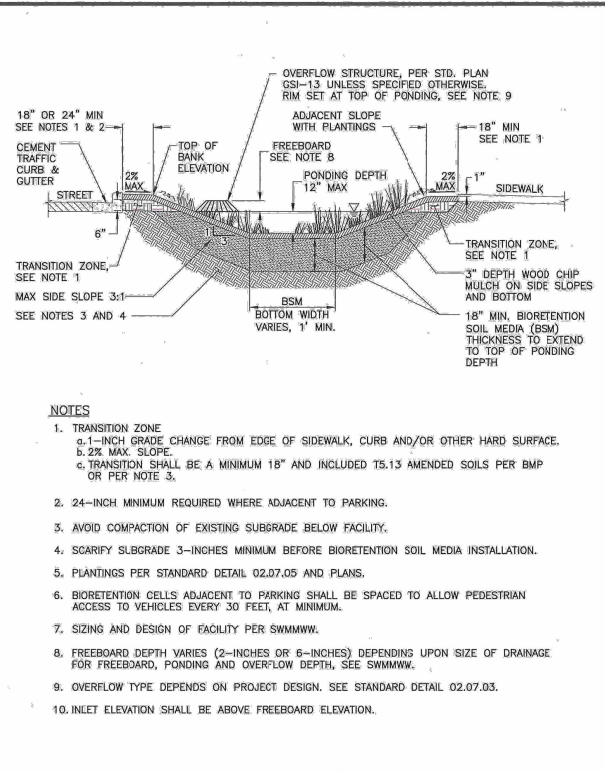
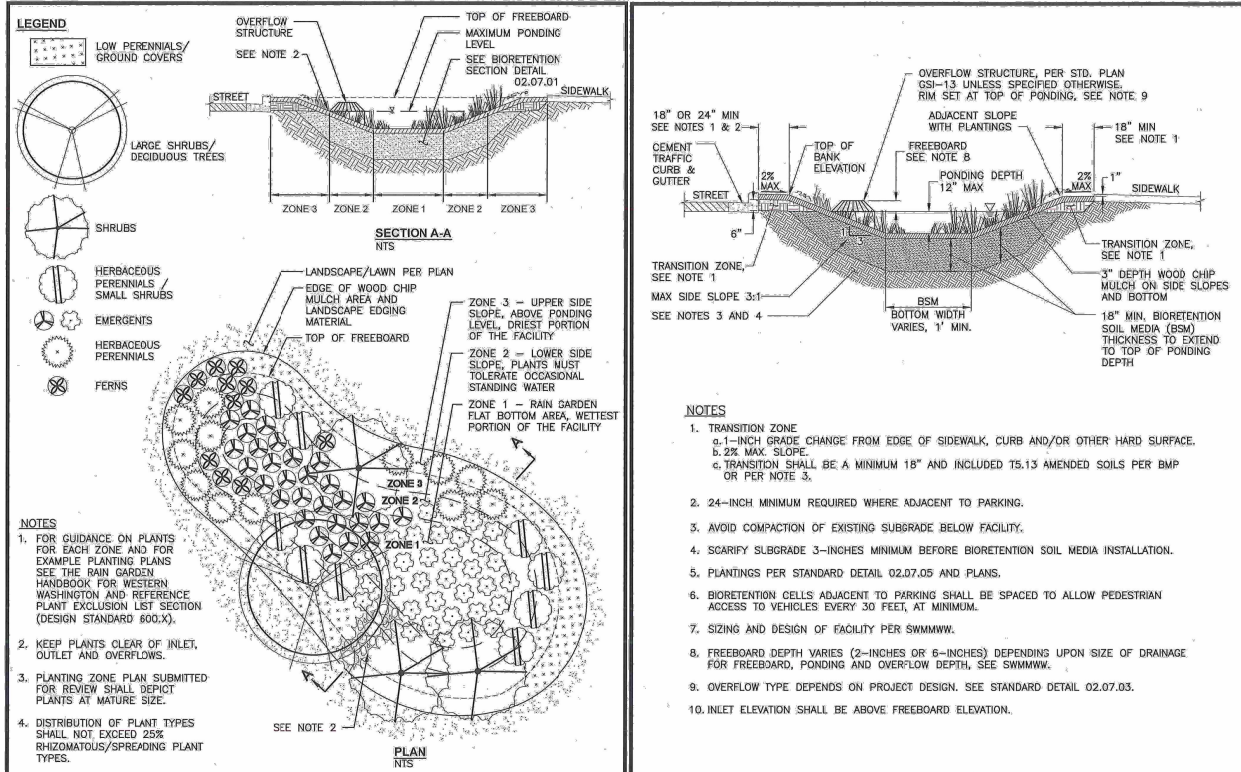

CITY OF PUYALLUP OFFICE OF THE CITY ENGINEER		BIORETENTION PLANTING ZONES		CITY OF PUYALLUP OFFICE OF THE CITY ENGINEER		BIORETENTION SECTION	
DESIGNED BY	CHECKED BY	DATE APPROVED	DATE APPROVED	DATE APPROVED	DATE APPROVED	DATE APPROVED	DATE APPROVED
WZG	RLP	02.07.05	02.07.05	02.07.05	02.07.05	02.07.05	02.07.05

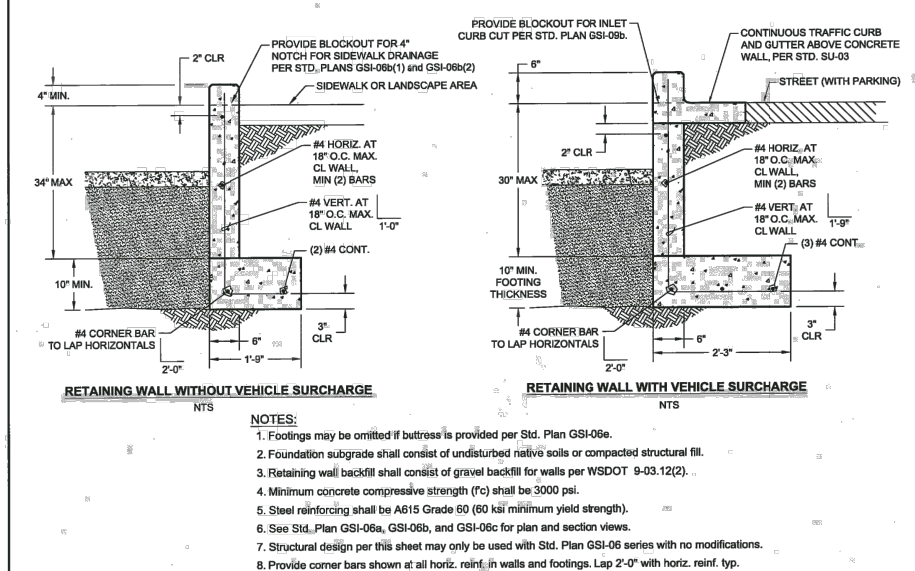

APPROVED FOR PUBLICATION

DATE: 3/1/22

WALLED BIORETENTION WALLS AND STRUCTURAL FOOTING

STANDARD PLAN NO. GSI-06d

GENERAL NOTE

- WALLS OVER 48-INCHES FROM BOTTOM OF FOOTING TO SEPARATE WALL REQUIRE SEPARATE BUILDING PERMIT.

APPROVED

BY: CITY OF PUYALLUP
ENGINEERING DEPARTMENT

DATE: _____

NOTE:
This approval is void after 1 year from approval date. The City will not be responsible for errors and/or omissions on these plans.
Field conditions may dictate changes to these plans as determined by the City Engineer.

REVISIONS	DATE	BY	DESIGNED WZG

ONE INCH AT FULL SCALE. IF NOT, SCALE ACCORDINGLY.

FILE NAME: 04-P50731200C-SD-HS
 JOB NO: 217-7312-004
 DATE: MARCH 2022

Parametrix
ENGINEERING, PLANNING, ENVIRONMENTAL SCIENCES

1019 39TH AVENUE SE, SUITE 100 | PUYALLUP, WA 98374
 P 253.604.6600
 WWW.PARAMETRIX.COM

PROJECT NAME

SOUTH HILL BUSINESS & TECHNOLOGY CENTER PARKING EXPANSION

PUYALLUP, WA

STORM DRAINAGE STANDARD DETAILS

DRAWING NO. 27 OF 58

SD-08

NOTE: SYMBOLS NOT TO SCALE

100% REVIEW SUBMITTAL

LAYOUT: 5B-09
 PATH: u:\P50\Projects\Clients\312-Benaroya\312-Benaroya\312-004-SHB&TDParkingExpansion\995\sc4105\SC4105.DWG
 PLOTTED BY: patitus DATE: Friday, February 25, 2022 1:07:10 PM

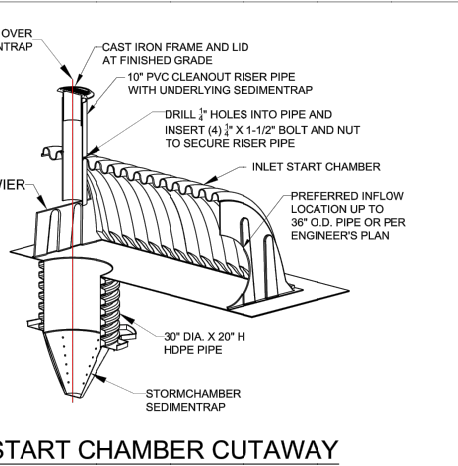
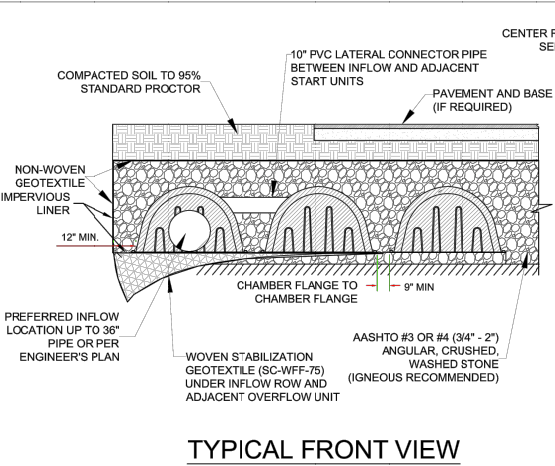
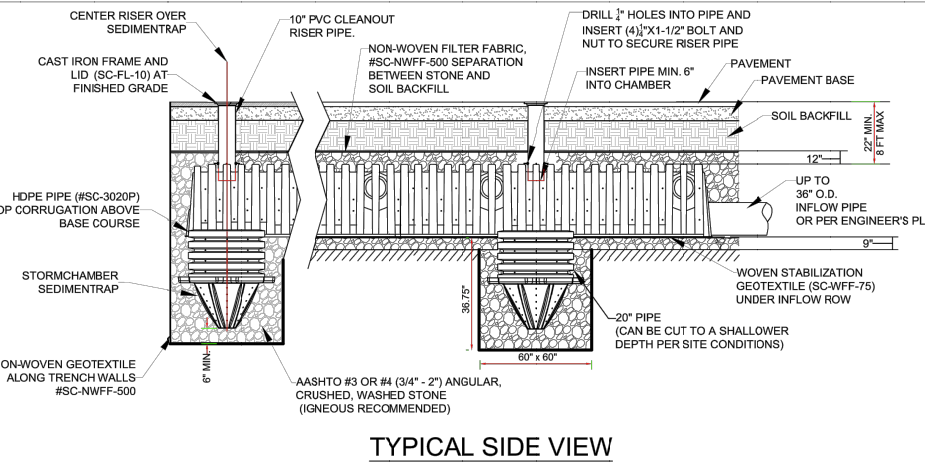
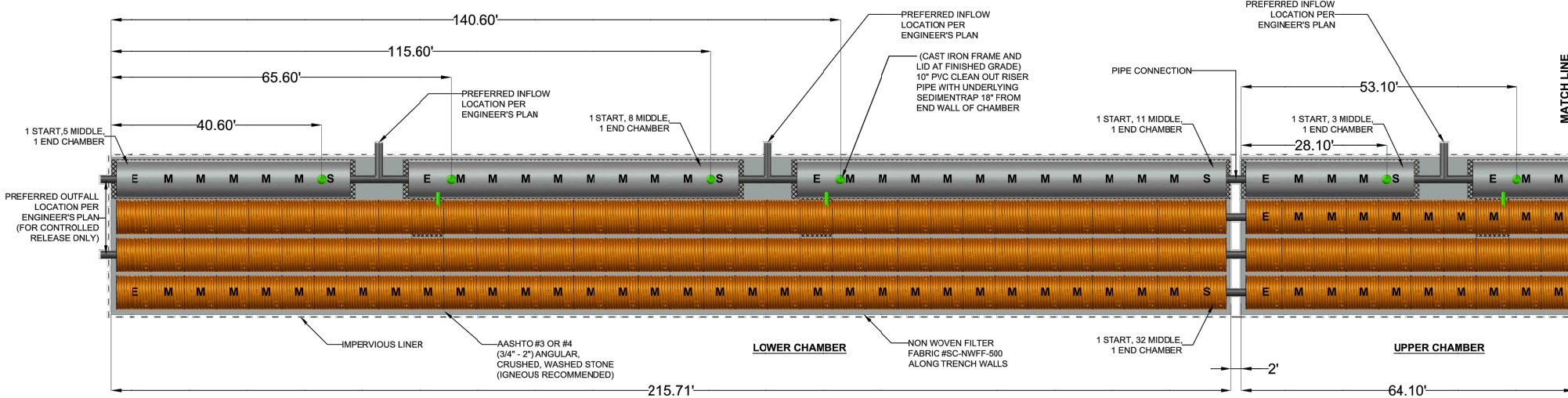
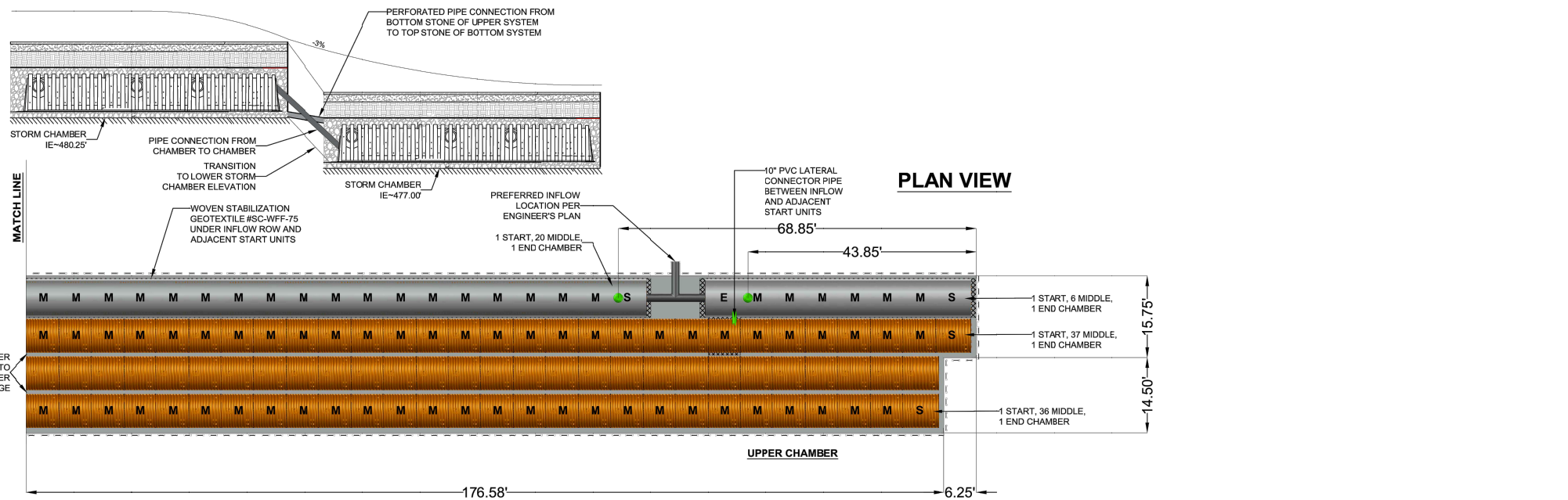

SC-44105 DIMENSIONS

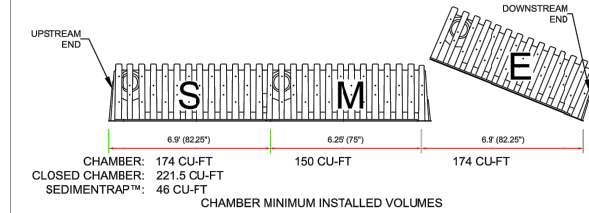
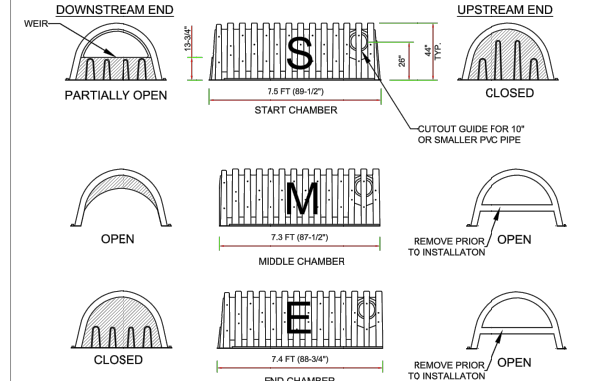
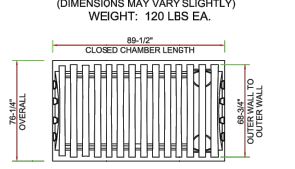

- NOTES:**
- START CHAMBERS (CLOSED AT THE SIDE PORTAL END) ARE PLACED AT THE INFLOW END OF THE ROWS.
 - BEGIN PLACEMENTS WITH START CHAMBERS AND END ROWS WITH END CHAMBERS.
 - PLACE FIRST RIB OF THE NEXT CHAMBER IN THE ROW OVER THE LAST RIB OF THE PREVIOUS CHAMBER.

MATERIAL LIST

DESCRIPTION	STOCK CODE	QTY	UNITS
CHAMBERS AND ACCESSORIES:			
START CHAMBER	SC-44105-S-O	12	EACH
MIDDLE CHAMBER	SC-44105-M-O	258	EACH
END CHAMBER	SC-44105-E-O	12	EACH
CLOSED CHAMBER	SC-44105-C-O	N/A	EACH
SEDIMENTRAP™	SC-ST	8	EACH
NON-WOVEN GEOTEXTILE	SC-NWFF-500	17	SQ FT
WOVEN STABILIZATION GEOTEXTILE	SC-WFF-75	6	SQ FT
30" X 20" HDPE PIPE FOR SEDIMENTRAP™	SC-3020P	8	EACH
10" CAST IRON FRAME AND LID	SC-FL-10	8	EACH
MATERIALS BY OTHERS:			
10" DIAMETER RISER PIPE	OTHERS	8	EACH
10" DIAMETER LATERAL PIPE	OTHERS	4	EACH
IN-PLACE EXCAVATION (NO BULKING FACTOR)	OTHERS	2694.26	CU YD
STONE BACKFILL	OTHERS	1736.62	CU YD
1/4" X 1-1/2" NUT AND BOLT	OTHERS	32	EACH
3" SCREWS	OTHERS	32	EACH
IMPERVIOUS LINER	OTHERS	2655.15	SQ YD

APPROVED

BY: _____
 CITY OF PUYALLUP
 ENGINEERING DEPARTMENT

DATE: _____

NOTE:
 This approval is void after 1 year from approval date. The City will not be responsible for errors and/or omissions on these plans.
 Field conditions may dictate changes to these plans as determined by the City Engineer.

PROJECT NAME : PUYALLUP, WA OFFICE PARK
 PROJECT LOCATION : PUYALLUP, WA

PROJECT # 1362
 DATE: 3/17/2021
 REVISION: 2/16/2022
 DRAWN BY: ARH



SC-44105 STORMCHAMBER LAYOUT

MEETS OR EXCEEDS ASTM F2922 AND ASTM F2787

NOTE: SYMBOLS NOT TO SCALE

100% REVIEW SUBMITTAL

REVISIONS	DATE	BY	DESIGNED WZG

ONE INCH AT FULL SCALE. IF NOT, SCALE ACCORDINGLY.

FILE NAME: 04-P50731200C-SD-HS
 JOB NO: 217-7312-004
 DATE: MARCH 2022

Parametrix
 ENGINEERING, PLANNING, ENVIRONMENTAL SCIENCES

1019 39TH AVENUE SE, SUITE 100 | PUYALLUP, WA 98374
 P 253.604.6600
 WWW.PARAMETRIX.COM

PROJECT NAME
SOUTH HILL BUSINESS & TECHNOLOGY CENTER PARKING EXPANSION
 PUYALLUP, WA

STORM DRAINAGE STANDARD DETAILS

DRAWING NO.
 28 OF 58
SD-09

PATH: u:\p50\Projects\Clients\312-Benaroya\217-7312-004-SHB&TCParkingExpansion\95\sea\cadd\dwg PLOTTED BY: patitus DATE: Friday, February 25, 2022 1:08:08 PM LAYOUT: GR-00

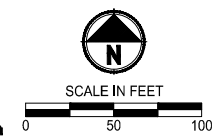
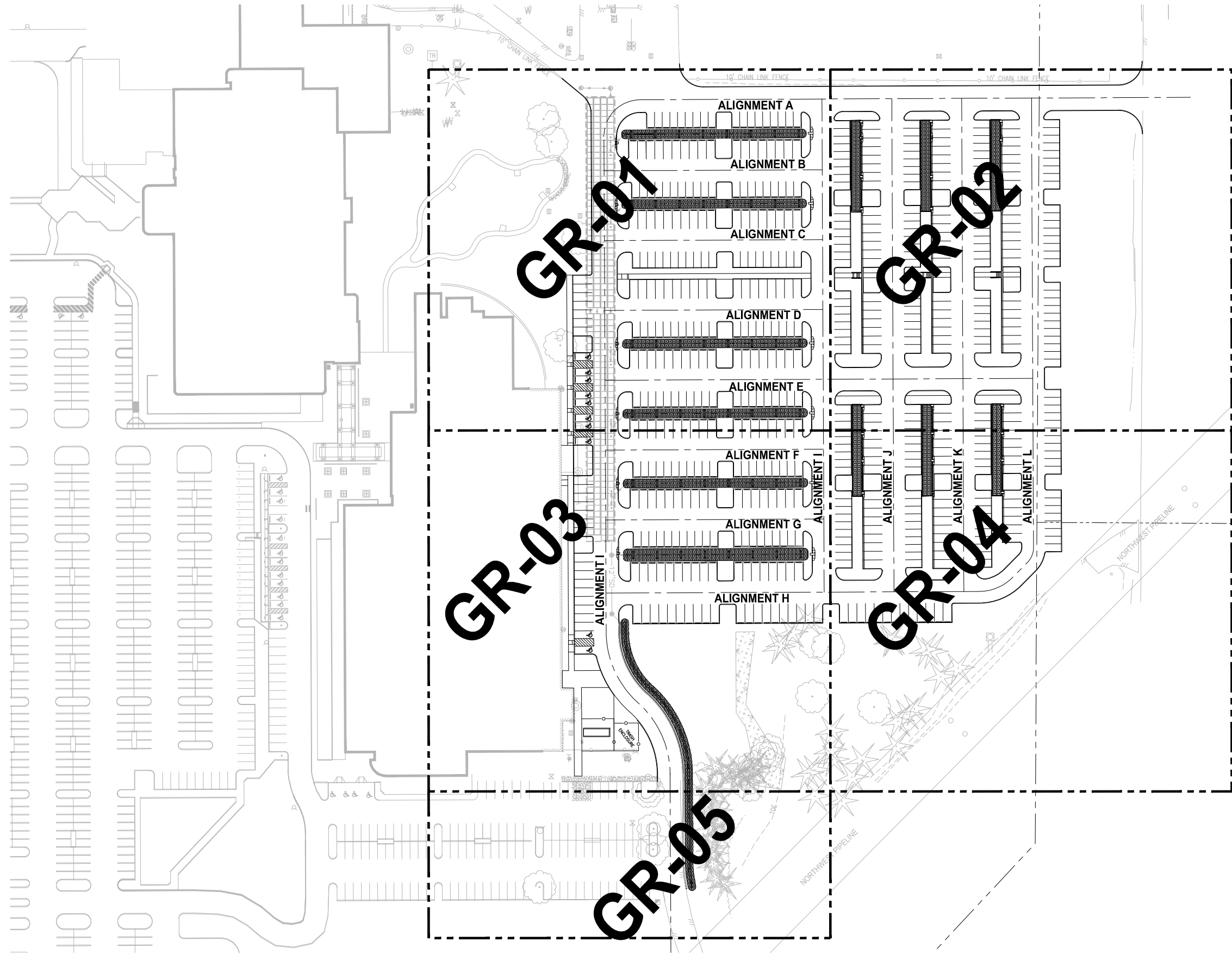

APPROVED
 BY: CITY OF PUYALLUP
 ENGINEERING DEPARTMENT
 DATE: _____
 NOTE:
 This approval is void after 1 year from approval date. The City will not be responsible for errors and/or omissions on these plans.
 Field conditions may dictate changes to these plans as determined by the City Engineer.

- LEGEND:**
- EXISTING MAJOR CONTOUR LINE
 - - - EXISTING MINOR CONTOUR LINE
 - PROPOSED MINOR CONTOUR LINE
 - - - PROPOSED MINOR CONTOUR LINE
 - ROADWAY CENTERLINE
 - - - PROPERTY BOUNDARY
 - - - - - CUT LIMITS
 - - - - - FILL LIMITS

- GENERAL NOTE:**
1. CONTRACTOR SHALL FURNISH AND INSTALL ALL MATERIALS AND EQUIPMENT NECESSARY TO COMPLETE THIS WORK.
 2. CONTRACTOR TO VERIFY ALL EXISTING ELEVATIONS AND GRADES.
 3. TYPICAL ROAD SECTIONS ARE SHOWN ON SHEET TS-01.
 4. GRADING POINT TABLES ARE SHOWN ON SHEETS GR-15 THROUGH GR-19.
 5. INFILTRATION PLANTER WALL HEIGHTS IDENTIFIES DIMENSION FROM BOTTOM OF FOOTING TO TOP OF WALL.

- CONSTRUCTION NOTE:**
- 1 SEE SHEET GR-15 FOR STAIR GRADING DETAILS.
 - 2 CONSTRUCT STAIRS AND HAND RAIL PER DETAIL ON SHEET GR-15.

NOTE: SYMBOLS NOT TO SCALE **100% REVIEW SUBMITTAL**

REVISIONS	DATE	BY	DESIGNED WZG

**ONE INCH AT FULL SCALE.
 IF NOT, SCALE ACCORDINGLY.**
 FILE NAME
 05-P50731200C-GR
 JOB No.
 217-7312-004
 DATE
 MARCH 2022

Parametrix
 ENGINEERING . PLANNING . ENVIRONMENTAL SCIENCES
 1019 39TH AVENUE SE, SUITE 100 | PUYALLUP, WA 98374
 P 253.604.6600
 WWW.PARAMETRIX.COM

PROJECT NAME
**SOUTH HILL BUSINESS &
 TECHNOLOGY CENTER
 PARKING EXPANSION**
 PUYALLUP, WA

**GRADING PLAN
 COMPOSITE**

DRAWING NO.
 29 OF 58
GR-00

APPROVED
 BY: CITY OF PUYALLUP
 ENGINEERING DEPARTMENT
 DATE: _____
 NOTE:
 This approval is void after 1 year from approval date. The City will not be responsible for errors and/or omissions on these plans.
 Field conditions may dictate changes to these plans as determined by the City Engineer.

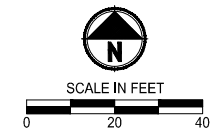

- LEGEND:**
- EXISTING MAJOR CONTOUR LINE
 - - - EXISTING MINOR CONTOUR LINE
 - PROPOSED MINOR CONTOUR LINE
 - PROPOSED MINOR CONTOUR LINE
 - ROADWAY CENTERLINE
 - PROPERTY BOUNDARY
 - - - - - CUT LIMITS
 - - - - - FILL LIMITS

- GENERAL NOTE:**
1. CONTRACTOR SHALL FURNISH AND INSTALL ALL MATERIALS AND EQUIPMENT NECESSARY TO COMPLETE THIS WORK.
 2. CONTRACTOR TO VERIFY ALL EXISTING ELEVATIONS AND GRADES.
 3. TYPICAL ROAD SECTIONS ARE SHOWN ON SHEET TS-01.
 4. GRADING POINT TABLES ARE SHOWN ON SHEETS GR-15 THROUGH GR-19.
 5. INFILTRATION PLANTER WALL HEIGHTS IDENTIFIES DIMENSION FROM BOTTOM OF FOOTING TO TOP OF WALL.

- CONSTRUCTION NOTE:**
- ① SEE SHEET GR-15 FOR STAIR GRADING DETAILS.
 - ② CONSTRUCT STAIRS AND HAND RAIL PER DETAIL ON SHEET GR-15.

NOTE: SYMBOLS NOT TO SCALE **100% REVIEW SUBMITTAL**

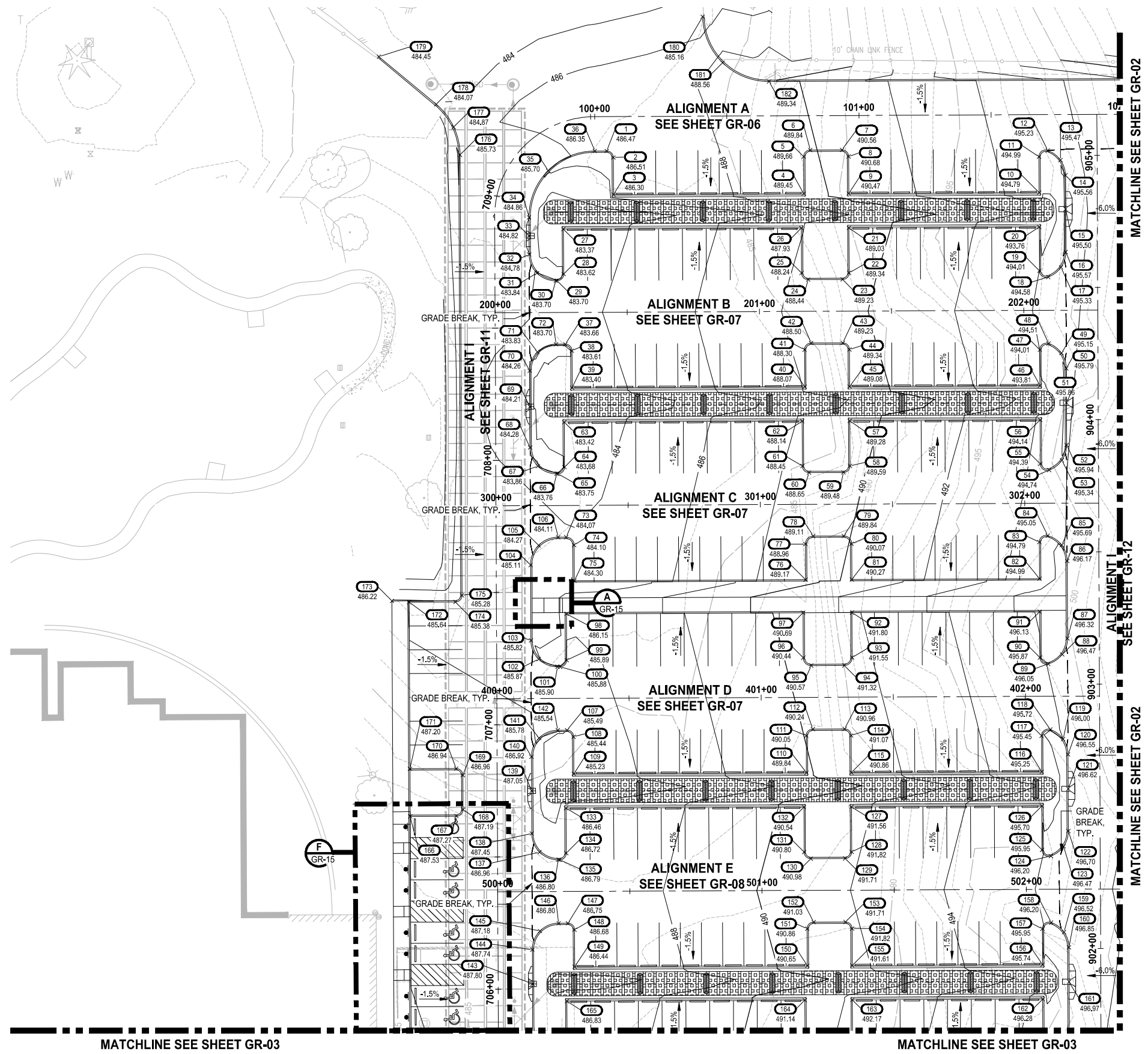

LAYOUT: GR-01
 PATH: u:\P50\Projects\Clients\7312-Berneyo\217-7312-004-SHB&CParkingExpansion\995\cadd\DWG
 PLOTTED BY: petrus DATE: Friday, February 25, 2022 1:08:14 PM

REVISIONS	DATE	BY	DESIGNED WZG

ONE INCH AT FULL SCALE.
 IF NOT, SCALE ACCORDINGLY
 FILE NAME
 OS-P50731200C-GR
 JOB No.
 217-7312-004
 DATE
 MARCH 2022

Parametrix
 ENGINEERING · PLANNING · ENVIRONMENTAL SCIENCES

1019 39TH AVENUE SE, SUITE 100 | PUYALLUP, WA 98374
 P 253.604.6600
 WWW.PARAMETRIX.COM

PROJECT NAME
SOUTH HILL BUSINESS & TECHNOLOGY CENTER PARKING EXPANSION
 PUYALLUP, WA

GRADING PLAN

DRAWING NO.
 30 OF 58
GR-01

LAYOUT: GR-02
PATH: u:\p50\Projects\Clients\312-Benaroya\217-7312-004-SHB&TCParkingExpansion\95\area\1\0\0\DWG
PLOTTED BY: patrix DATE: Friday, February 25, 2022 1:08:25 PM

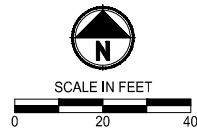

APPROVED
BY: CITY OF PUYALLUP
ENGINEERING DEPARTMENT
DATE: _____
NOTE:
This approval is void after 1 year from approval date. The City will not be responsible for errors and/or omissions on these plans.
Field conditions may dictate changes to these plans as determined by the City Engineer.

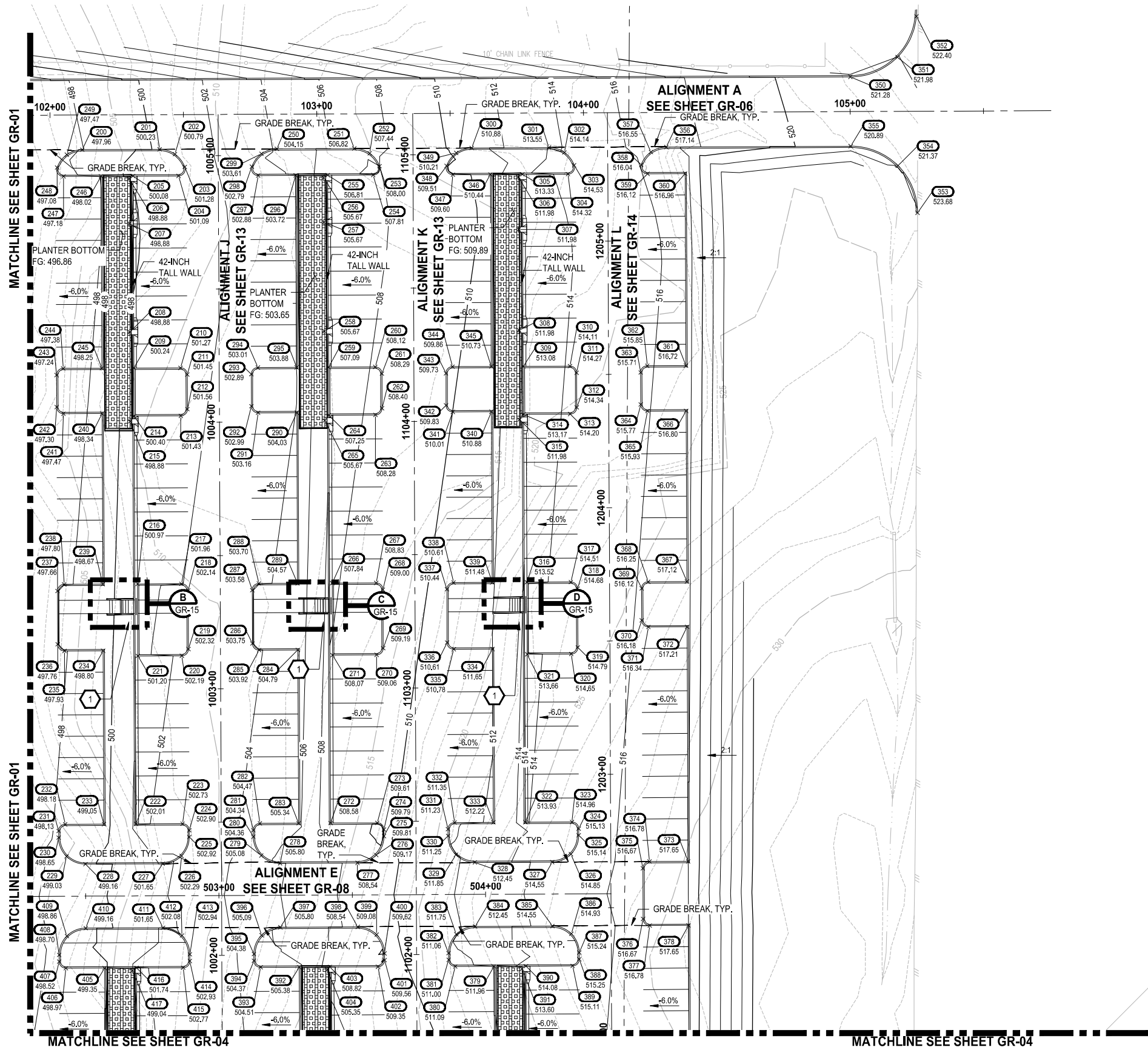

- LEGEND:**
- EXISTING MAJOR CONTOUR LINE
 - EXISTING MINOR CONTOUR LINE
 - PROPOSED MINOR CONTOUR LINE
 - PROPOSED MAJOR CONTOUR LINE
 - ROADWAY CENTERLINE
 - PROPERTY BOUNDARY
 - CUT LIMITS
 - FILL LIMITS

- GENERAL NOTE:**
- CONTRACTOR SHALL FURNISH AND INSTALL ALL MATERIALS AND EQUIPMENT NECESSARY TO COMPLETE THIS WORK.
 - CONTRACTOR TO VERIFY ALL EXISTING ELEVATIONS AND GRADES.
 - TYPICAL ROAD SECTIONS ARE SHOWN ON SHEET TS-01.
 - GRADING POINT TABLES ARE SHOWN ON SHEETS GR-15 THROUGH GR-19.
 - INFILTRATION PLANTER WALL HEIGHTS IDENTIFIES DIMENSION FROM BOTTOM OF FOOTING TO TOP OF WALL.

- CONSTRUCTION NOTE:**
- 1 SEE SHEET GR-15 FOR STAIR GRADING DETAILS.
 - 2 CONSTRUCT STAIRS AND HAND RAIL PER DETAIL ON SHEET GR-15.

NOTE:
SYMBOLS NOT TO SCALE

100% REVIEW SUBMITTAL

NO.	REVISIONS	DATE	BY	DESIGNED WZG

ONE INCH AT FULL SCALE.
IF NOT, SCALE ACCORDINGLY
FILE NAME: 05-P50731200C-GR
JOB No: 217-7312-004
DATE: MARCH 2022

Parametrix
ENGINEERING, PLANNING, ENVIRONMENTAL SCIENCES
1019 39TH AVENUE SE, SUITE 100 | PUYALLUP, WA 98374
P 253.604.6600
WWW.PARAMETRIX.COM

PROJECT NAME
SOUTH HILL BUSINESS & TECHNOLOGY CENTER PARKING EXPANSION
PUYALLUP, WA

GRADING PLAN

DRAWING NO.
31 OF 58
GR-02

MATCHLINE SEE SHEET GR-01

MATCHLINE SEE SHEET GR-01

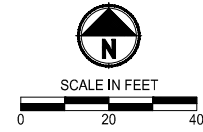

APPROVED

BY: _____
CITY OF PUYALLUP
ENGINEERING DEPARTMENT

DATE: _____

NOTE:
This approval is void after
1 year from approval date.
The City will not be responsible
for errors and/or omissions on
these plans.
Field conditions may dictate
changes to these plans as
determined by the City
Engineer.

- LEGEND:**
- EXISTING MAJOR CONTOUR LINE
 - EXISTING MINOR CONTOUR LINE
 - PROPOSED MINOR CONTOUR LINE
 - PROPOSED MINOR CONTOUR LINE
 - ROADWAY CENTERLINE
 - PROPERTY BOUNDARY
 - CUT LIMITS
 - FILL LIMITS

- GENERAL NOTE:**
1. CONTRACTOR SHALL FURNISH AND INSTALL ALL MATERIALS AND EQUIPMENT NECESSARY TO COMPLETE THIS WORK.
 2. CONTRACTOR TO VERIFY ALL EXISTING ELEVATIONS AND GRADES.
 3. TYPICAL ROAD SECTIONS ARE SHOWN ON SHEET TS-01.
 4. GRADING POINT TABLES ARE SHOWN ON SHEETS GR-15 THROUGH GR-19.
 5. INFILTRATION PLANTER WALL HEIGHTS IDENTIFIES DIMENSION FROM BOTTOM OF FOOTING TO TOP OF WALL.

- CONSTRUCTION NOTE:**
- 1 SEE SHEET GR-15 FOR STAIR GRADING DETAILS.
 - 2 CONSTRUCT STAIRS AND HAND RAIL PER DETAIL ON SHEET GR-15.

NOTE: SYMBOLS NOT TO SCALE

100% REVIEW SUBMITTAL

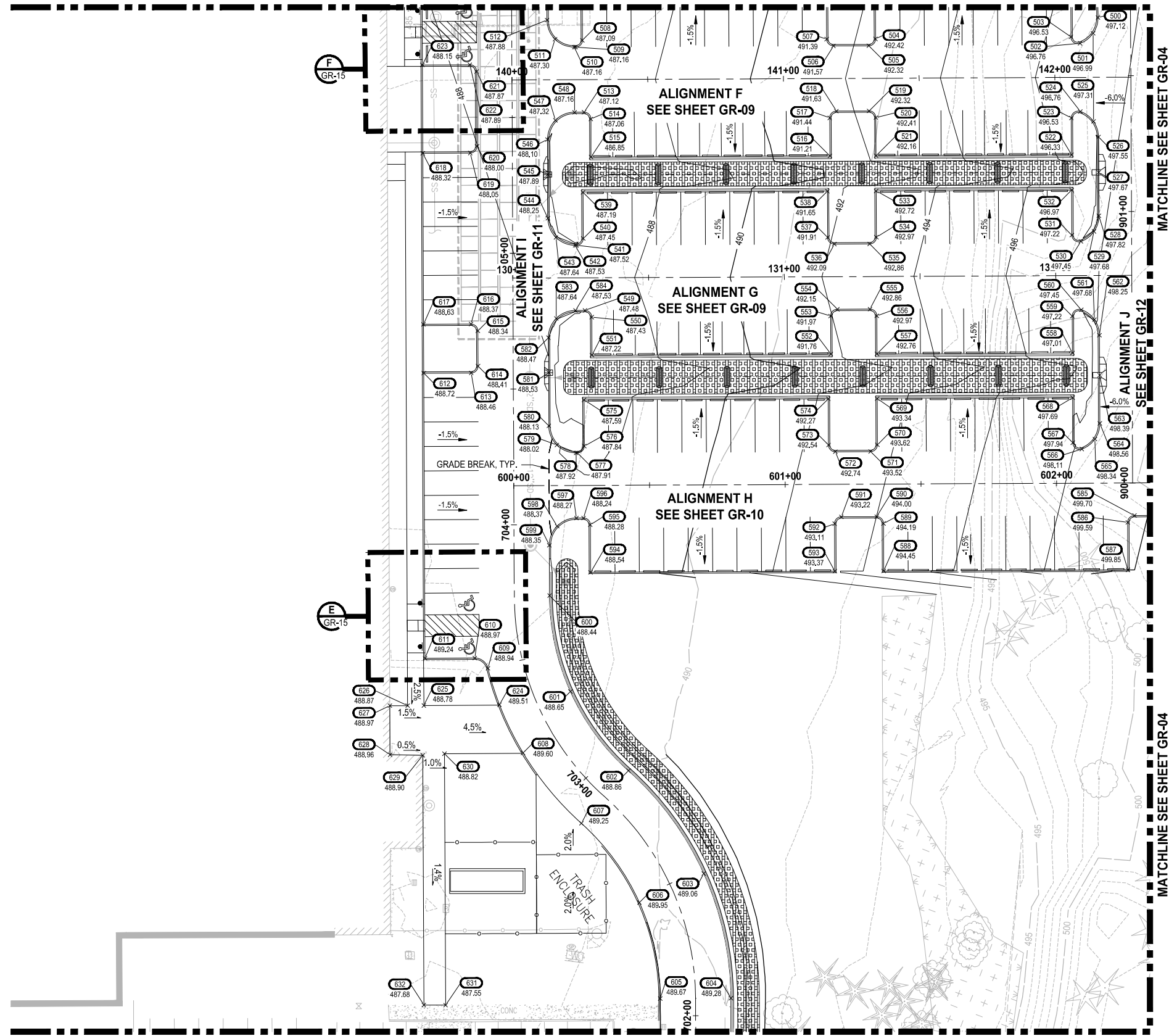

MATCHLINE SEE SHEET GR-05

MATCHLINE SEE SHEET GR-05

LAYOUT: GR-03
 PATH: u:\p50\Projects\Clients\312-Benaroya\217-7312-004-SHB&TCParkingExpansion\995\ea\cadd\dwg
 PLOTTED BY: pattius DATE: Friday, February 25, 2022 1:08:28 PM

REVISIONS	DATE	BY	DESIGNED WZG

**ONE INCH AT FULL SCALE.
IF NOT, SCALE ACCORDINGLY**

FILE NAME
05-P50731200C-GR

JOB No.
217-7312-004

DATE
MARCH 2022

Parametrix
ENGINEERING, PLANNING, ENVIRONMENTAL SCIENCES

1019 39TH AVENUE SE, SUITE 100 | PUYALLUP, WA 98374
P 253.604.6600
WWW.PARAMETRIX.COM

PROJECT NAME
SOUTH HILL BUSINESS & TECHNOLOGY CENTER PARKING EXPANSION
PUYALLUP, WA

GRADING PLAN

DRAWING NO.
32 OF 58
GR-03

LAYOUT: GR-04 PATH: u:\p50\Projects\Clients\312-Benaroya\217-7312-004-SHB&TCParkingExpansion\995\ea\cadd\dwg PLOTTED BY: pattius DATE: Friday, February 25, 2022 1:08:35 PM

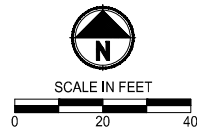
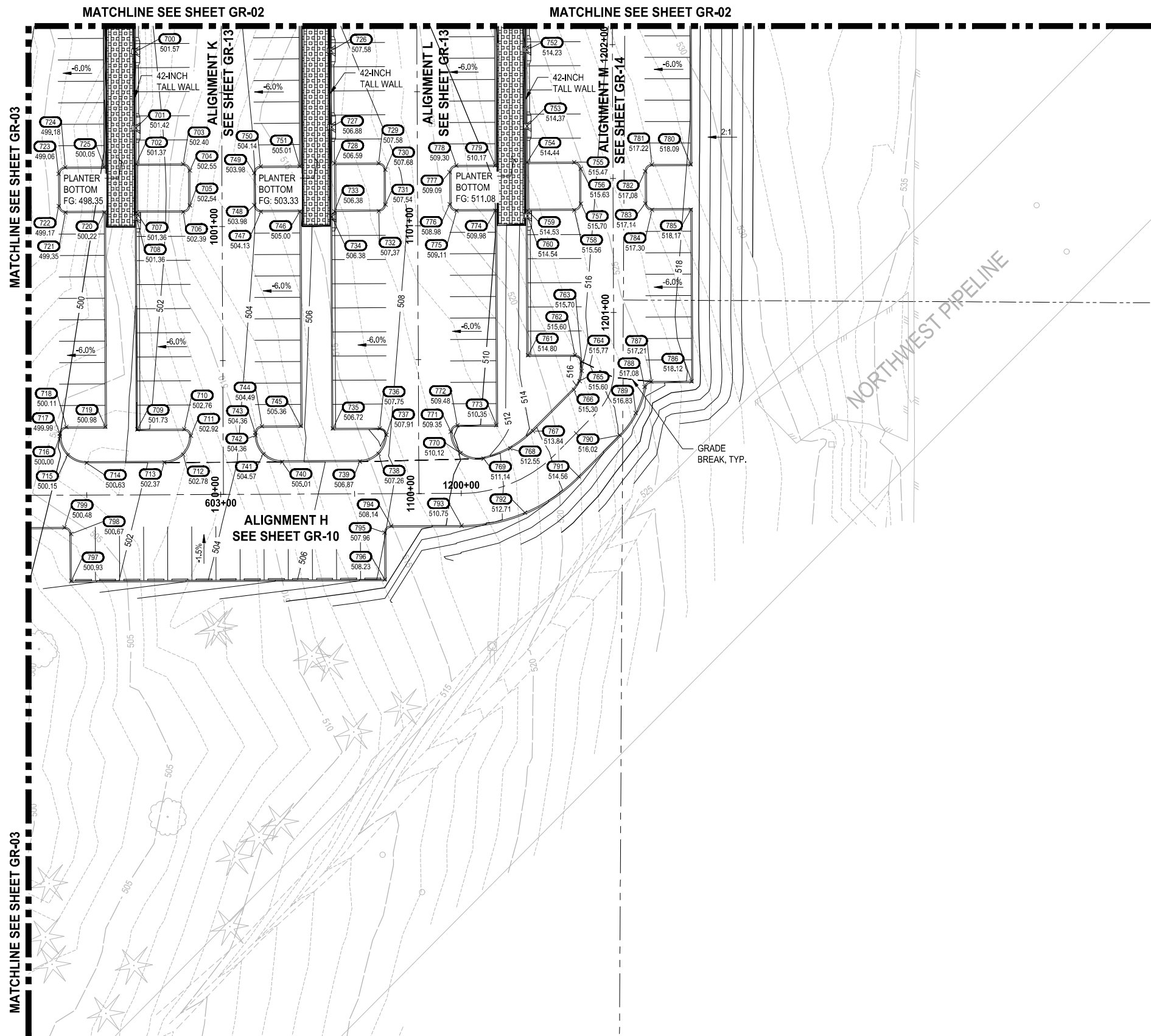

APPROVED
 BY: CITY OF PUYALLUP
 ENGINEERING DEPARTMENT
 DATE: _____
 NOTE:
 This approval is void after 1 year from approval date. The City will not be responsible for errors and/or omissions on these plans.
 Field conditions may dictate changes to these plans as determined by the City Engineer.

- LEGEND:**
- EXISTING MAJOR CONTOUR LINE
 - EXISTING MINOR CONTOUR LINE
 - PROPOSED MINOR CONTOUR LINE
 - PROPOSED MINOR CONTOUR LINE
 - ROADWAY CENTERLINE
 - PROPERTY BOUNDARY
 - CUT LIMITS
 - FILL LIMITS

- GENERAL NOTE:**
1. CONTRACTOR SHALL FURNISH AND INSTALL ALL MATERIALS AND EQUIPMENT NECESSARY TO COMPLETE THIS WORK.
 2. CONTRACTOR TO VERIFY ALL EXISTING ELEVATIONS AND GRADES.
 3. TYPICAL ROAD SECTIONS ARE SHOWN ON SHEET TS-01.
 4. GRADING POINT TABLES ARE SHOWN ON SHEETS GR-15 THROUGH GR-19.
 5. INFILTRATION PLANTER WALL HEIGHTS IDENTIFIES DIMENSION FROM BOTTOM OF FOOTING TO TOP OF WALL.

- CONSTRUCTION NOTE:**
- 1 SEE SHEET GR-15 FOR STAIR GRADING DETAILS.
 - 2 CONSTRUCT STAIRS AND HAND RAIL PER DETAIL ON SHEET GR-15.

NOTE:
 SYMBOLS NOT TO SCALE

100% REVIEW SUBMITTAL

REVISIONS	DATE	BY	DESIGNED WZG

ONE INCH AT FULL SCALE.
 IF NOT, SCALE ACCORDINGLY
 FILE NAME: 05-P50731200C-GR
 JOB No: 217-7312-004
 DATE: MARCH 2022

Parametrix
 ENGINEERING, PLANNING, ENVIRONMENTAL SCIENCES
 1019 39TH AVENUE SE, SUITE 100 | PUYALLUP, WA 98374
 P 253.604.6600
 WWW.PARAMETRIX.COM

PROJECT NAME
SOUTH HILL BUSINESS & TECHNOLOGY CENTER PARKING EXPANSION
 PUYALLUP, WA

GRADING PLAN

DRAWING NO.
 33 OF 58
GR-04

PATH: u:\p50\Projects\Clients\312-Beneroya\217-7312-004-SHB&TCParkingExpansion\995\ea\c\add\dwg PLOTTED BY: pattius DATE: Friday, February 25, 2022 1:08:38 PM LAYOUT: GR-05

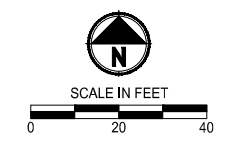
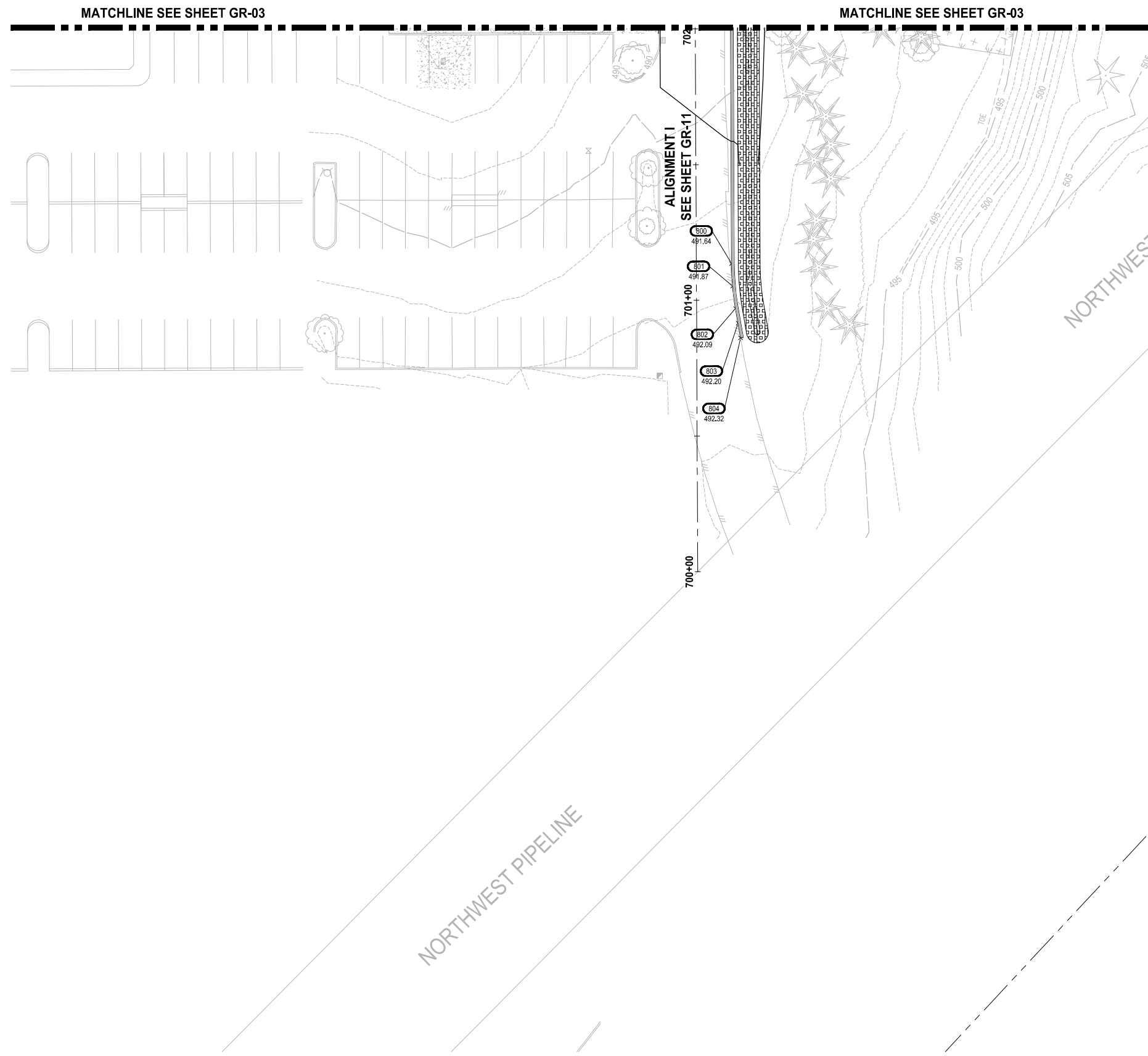

APPROVED
 BY: CITY OF PUYALLUP
 ENGINEERING DEPARTMENT
 DATE: _____
 NOTE:
 This approval is void after 1 year from approval date. The City will not be responsible for errors and/or omissions on these plans.
 Field conditions may dictate changes to these plans as determined by the City Engineer.

- LEGEND:**
- EXISTING MAJOR CONTOUR LINE
 - - - EXISTING MINOR CONTOUR LINE
 - PROPOSED MINOR CONTOUR LINE
 - - - PROPOSED MINOR CONTOUR LINE
 - ROADWAY CENTERLINE
 - - - PROPERTY BOUNDARY
 - - - - - CUT LIMITS
 - - - - - FILL LIMITS

- GENERAL NOTE:**
1. CONTRACTOR SHALL FURNISH AND INSTALL ALL MATERIALS AND EQUIPMENT NECESSARY TO COMPLETE THIS WORK.
 2. CONTRACTOR TO VERIFY ALL EXISTING ELEVATIONS AND GRADES.
 3. TYPICAL ROAD SECTIONS ARE SHOWN ON SHEET TS-01.
 4. GRADING POINT TABLES ARE SHOWN ON SHEETS GR-15 THROUGH GR-19.
 5. INFILTRATION PLANTER WALL HEIGHTS IDENTIFIES DIMENSION FROM BOTTOM OF FOOTING TO TOP OF WALL.

- CONSTRUCTION NOTE:**
- ① SEE SHEET GR-15 FOR STAIR GRADING DETAILS.
 - ② CONSTRUCT STAIRS AND HAND RAIL PER DETAIL ON SHEET GR-15.

NOTE:
 SYMBOLS NOT TO SCALE

100% REVIEW SUBMITTAL

REVISIONS	DATE	BY	DESIGNED WZG
			DRAWN RLP
			CHECKED DMS
			APPROVED DMS

ONE INCH AT FULL SCALE.
 IF NOT, SCALE ACCORDINGLY
 FILE NAME
 05-P50731200C-GR
 JOB No.
 217-7312-004
 DATE
 MARCH 2022

Parametrix
 ENGINEERING · PLANNING · ENVIRONMENTAL SCIENCES
 1019 39TH AVENUE SE, SUITE 100 | PUYALLUP, WA 98374
 P 253.604.6600
 WWW.PARAMETRIX.COM

PROJECT NAME
SOUTH HILL BUSINESS & TECHNOLOGY CENTER PARKING EXPANSION
 PUYALLUP, WA

GRADING PLAN

DRAWING NO.
 34 OF 58
GR-05

Appendix C

Construction Stormwater Pollution Prevention Plan (CSWPPP)

South Hill Business & Technology Center Parking Expansion Project Construction Stormwater Pollution Prevention Plan (CSWPPP)

Prepared for

The Benaroya Company
3600 136th Place SE, Suite 250
Bellevue, WA 98006



Prepared by

Parametrix
1019 39th Avenue SE, Suite 100
Puyallup, WA 98374
T. 253.604.6600 F. 1.855.542.6353
www.parametrix.com

CITATION

Parametrix, 2022. South Hill Business & Technology Center Parking Expansion Project Construction Stormwater Pollution Prevention Plan (CSWPPP). Prepared by Parametrix, Puyallup, Washington. March 2022

CONTACT INFORMATION/RESPONSIBLE PARTIES

Construction Stormwater General Permit (CSWGP) Permittee/Owner:

The Benaroya Company
3600 136th Place SE, Suite 250
Bellevue, WA 98006

Certified Erosion and Sediment Control Lead (CESCL):

TBD
Phone:

SWPPP prepared by:

Zac Garrard, EIT
Parametrix, Inc.
(503)-416-6850
zgarrard@parametrix.com

CSWPPP preparation date:

March 2, 2022

Project Construction Date

Construction Activity	Date of Completion
Project Start	Spring/Summer 2022
Install Erosion and Sediment Control BMPs	Spring/Summer 2022
Clearing and Demolition Begin	Spring/Summer 2022
Final Stabilization	Fall 2022
Remove Erosion and Sediment Control BMPs	Fall 2022
Project End	Fall 2022

CERTIFICATION

The technical material and data contained in this document were prepared under the supervision and direction of the undersigned, whose seal, as a professional engineer licensed to practice as such, is affixed below.



Prepared by Zac Garrard, EIT

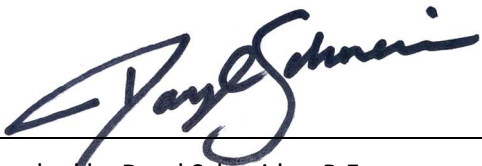

Checked by Daryl Schneider, P.E.



Approved by Daryl Schneider P.E.



This Page Intentionally Left Blank.

TABLE OF CONTENTS

1. PROJECT DESCRIPTION	1
1.1 Location.....	1
1.2 Project Overview.....	1
2. EXISTING SITE CONDITIONS.....	2
2.1 Existing Topography and Vegetation	2
2.2 Existing Drainage System	2
2.3 Adjacent Areas	3
3. CRITICAL AREAS	3
4. EROSION PROBLEM AREAS.....	3
5. CONSTRUCTION STORMWATER POLLUTION PREVENTION ELEMENTS.....	3
5.1 Objective of the Stormwater Pollution Prevention Plan	3
5.2 Summary of Elements.....	4
5.3 Element #1: Preserve Vegetation/Mark Clearing Limits.....	4
5.4 Element #2: Establish Construction Access	5
5.5 Element #3: Control Flow Rates.....	5
5.6 Element #4: Install Sediment Controls.....	6
5.7 Element #5: Stabilize Soils.....	7
5.8 Element #6: Protect Slopes.....	8
5.9 Element #7: Protect Drain Inlets.....	8
5.10 Element #8: Stabilize Channels and Outlets	9
5.11 Element #9: Control Pollutants.....	9
5.12 Element #10: Control Dewatering	10
5.13 Element #11: Maintain BMPs.....	10
5.14 Element #12: Manage the Project	10
5.14.1 Phasing of Construction.....	10
5.14.2 Seasonal Work Limitations	11
5.14.3 Inspection and Monitoring	11
5.14.4 Maintenance of the SWPPP.....	11
5.15 Element #13: Protect Low-Impact Development (LID) BMPs.....	12

TABLE OF CONTENTS (CONTINUED)

6. ESTIMATED CONSTRUCTION SCHEDULE	12
7. REPORTING AND RECORD KEEPING	13
7.1 Record Keeping	13
7.1.1 Site Logbook	13
7.1.2 Records Retention.....	13
7.1.3 Updating the SWPPP	13
7.2 Reporting.....	14
7.2.1 Discharge Monitoring Reports	14
7.2.2 Notification of Noncompliance	14
8. SITE PLAN	15

LIST OF FIGURES

Figure 1 Project Vicinity Map	1
-------------------------------------	---

APPENDICES

A Erosion and Sediment Control BMPs	
-------------------------------------	--

ACRONYMS AND ABBREVIATIONS

AC	Acres
BMPs	best management practices
CESCL: TBD	Certified Erosion and Sediment Control Lead
CSWGP	Construction Stormwater General Permit
CSWPPP	Construction Stormwater Pollution Prevention Plan
CWA	Clean Water Act
CY	Cubic Yards
DDECM	Drainage Design and Erosion Control Manual
DMR	Discharge Monitoring Report
Ecology	Washington State Department of Ecology
EPA	United States Environmental Protection Agency
GULD	General Use Level Designation
LID	low-impact development
NPDES	National Pollutant Discharge Elimination System
pH	Power of Hydrogen
SPCC	Spill Prevention, Control, and Countermeasures
SF	Square Feet
su	Standard Units
SWMMWW	2019 Stormwater Management Manual for Western Washington
TMDL	total maximum daily load
TESC	Temporary Erosion and Sediment Control
WAC	Washington Administrative Code
WSDOT	Washington Department of Transportation
WWHM	Western Washington Hydrology Model

1. PROJECT DESCRIPTION

1.1 Location

The South Hill Business & Technology Center Parking Expansion project proposes to expand their office park parking lot on roughly 10-acres undeveloped land in Puyallup, WA. The project site is generally located in southeast Puyallup, WA north of SE 39th Avenue east of Bradley Lake and west of Pierce College. The parking expansion will occur on the eastern portion of the existing office park currently a mixture of gravel maintenance yard area and wooded slopes.

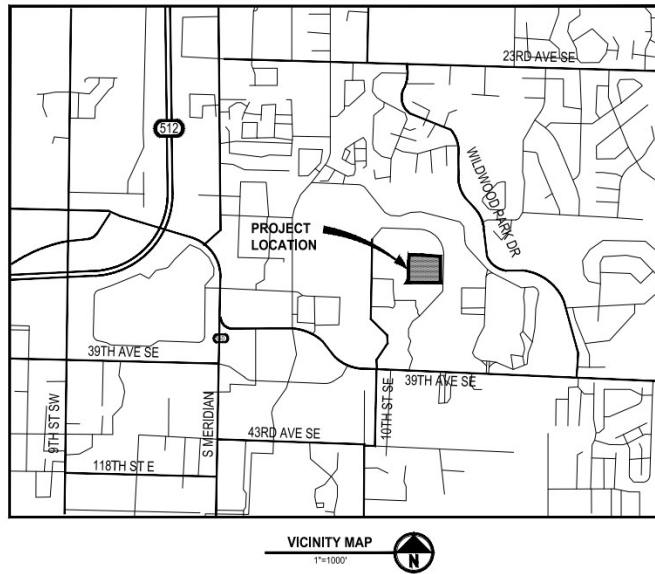

Figure 1 Project Vicinity Map

The proposed construction location and boundaries can be found in the Civil Plans.

1.2 Project Overview

The Parking Expansion project proposes to construct parking stalls, roughly 6.71-acres of circulation roads, pedestrian walkways, stormwater planters, and site lighting. The site will be mass graded to provide moderate slopes for the parking and roadways, and generally it will follow the existing grades by gradually rising to the east to the extent of construction limits. The surface parking lot will be split into various drive aisles delineating the stalls with landscape or walkways breaking up the rows of parking. Underground stormwater detention chambers will be used in conjunction with water quality swales to manage all new runoff generated as a result of the project. All runoff generated on-site will be treated to meet water quality standards prior to discharge into infiltration galleries or underground detention chambers.

Construction activities of the proposed project will include:

- Clearing and grubbing a wooded hillside
- Demoing a gravel and asphalt maintenance yard
- Grading and mass hauling earth

- Paving parking and accessible stalls, driveways, and circulatory roads
- Pouring sidewalks, curbs, and gutters
- Installing vegetated infiltration galleries, swales, and underground detention chambers

The wooded hillside will be cleared, grubbed, and mass graded to moderate slopes shallower than the existing slopes. Existing vegetation outside of the proposed construction activities will remain as is including a delineated wetland area. The Contractor shall manage, dispose, and reuse/recycle all waste and debris from construction activities to an approved facility.

Upon completion of the excavation and grading work, all areas where topsoil has been disturbed will be stabilized by an appropriate construction BMP. The Contractor will blend and grade the backfill soils into the surrounding grade to ensure no ponding and to provide positive drainage away from roadway subgrade and building foundations.

The finished site will be approximately 70% impervious with 5.5-acres of paved surfaces and 2.75-acres of pervious landscaping and stormwater management facilities.

Total disturbed acreage: 8.30 – acres

Total site area: 9.88 – acres

Earthwork Quantities:

Cut: 34,932 CY

Fill: 4,282 CY

Net: 30,650 CY (Export)

2. EXISTING SITE CONDITIONS

2.1 Existing Topography and Vegetation

The Parking Expansion project will occur in the east-central portion of the existing business park roughly 9.88-acres in size, which consists of a gravel maintenance yard area adjacent to the eastern building face and extends into an undeveloped wood area in the slopes extending away to the east. The maintenance yard is previously graded and relatively flat with increasing slopes stretching into the wooded area up to match an existing circulation road. The wooded area varies in steepness of slopes, but generally extends to the east with a few areas defined by flatter reliefs and ridges. The wooded area is densely covered in various cedar and fir trees, shrubs, and thickets of blackberry vines.

The topography of the site varies with slopes from 0% to 33%.

A geotechnical investigation identified that the site sits on fill overlying complex layering of recessional outwash/ice contact deposits. The near-surface deposits generally consist of medium dense silty sand with variable gravel content. In some of the test pits cobbles were encountered and in others clean sand and gravel were present.

2.2 Existing Drainage System

The maintenance yard composed of various gravel, asphalt, and concrete hard surfaces gradually slopes away from the eastern building face at slopes $\leq 2.0\%$ with storm drain inlets and structures through the

area for runoff generated from these surfaces, which are conveyed through a storm pipe network to the northwest of the site eventually outfalling into Bradley Lake.

The wooded area is densely covered in various types of vegetation. Rainfall over this area does not produce the same concentration of runoff as the developed areas due to abstractions in the hydrologic process as a result of the foliage. Stormwater is managed much closer to the initial source of rainfall by collecting, ponding, and infiltrating into the existing soils. Rainfall over this area does not produce the same concentration of runoff as the developed areas due to abstractions in the hydrologic process as a result of the foliage. Stormwater is managed much closer to the initial source of rainfall by collecting, ponding, and infiltrating into the existing soils. Runoff that does collect and sheet flow down the slopes of the wooded area is collected in a delineated wetland near the south-central end of the project area where it ponds. Other runoff collects at the edge of the maintenance yard.

2.3 Adjacent Areas

The project site is surrounded by an existing office park that is already developed. Two separate office buildings border the site to the north and west, and the park's circulation road borders on the south and east.

3. CRITICAL AREAS

A wetland area was delineated and reported during the initial survey. There are no proposed construction activities within the wetland or wetland buffer to minimize the impacts to the wetland. Proposed runoff will disperse through a vegetated buffer prior to interacting with the wetlands. The contributing runoff is limited, and the preserved drainage path to the wetlands should limit any hydromodifications to the area.

During the construction process, the wetland area will be protected from construction stormwater pollutants by BMPs installed around the area including but not limited to silt fences and straw wattles.

4. EROSION PROBLEM AREAS

There are no specific areas identified as erosion prone or higher susceptibility. Surrounding tree cover reduces wind gusts and rainfall minimizes dust and airborne particles. Existing slopes that angle away from the existing maintenance yard up to 3:1 (H:V), which should be observed as existing vegetation is removed. The primary anticipated erosion is sediment laden runoff as uncovered areas of the site encounter rainfall. Precautions and observations of exposed surface will be critical to minimize erosion and prevent/reduce stormwater pollution.

5. CONSTRUCTION STORMWATER POLLUTION PREVENTION ELEMENTS

5.1 Objective of the Stormwater Pollution Prevention Plan

The purpose of a Construction Stormwater Pollution Prevention Plan (SWPPP) is to describe the potential for erosion, sediment, and pollution problems on a construction project. The SWPPP also

explains and illustrates the measures to be taken on the construction site to control these problems. This SWPPP is prepared according to the guidance of the 2019 Stormwater Management Manual for Western Washington – Washington State Department of Ecology (DOE). The DOE manual describes thirteen necessary elements of construction stormwater pollution prevention. These thirteen elements include: preserving vegetation/mark clearing limits, establish construction access, control flow rates, install sediment controls, stabilize soils, protect slopes, protect drain inlets, stabilize channels and outlets, control pollutants, control de-watering, maintain Best Management Practices (BMPs), manage the project, and protect low-impact development BMPs. These elements have been addressed as follows.

5.2 Summary of Elements

The BMPs listed in this report, or their equivalent, are required. Any revisions by the contractor to the BMPs listed in the SWPPP shall be approved by the Engineer. Therefore, if the contractor does not require a BMP or needs to modify a BMP, the contractor shall document the reasons and update the SWPPP to match what is being implemented in the field. A copy of the BMPs can be found in Appendix A.

5.3 Element #1: Preserve Vegetation/Mark Clearing Limits

The clearing limits shall be marked prior to any clearing to restrict clearing to the approved limits. A high visibility fence shall be installed to delineate the extents of construction activities in accordance with BMP 103. No clearing or grubbing will begin until the limits have been delineated. The Contractor shall use best judgement selecting of the type of fencing (high orange fencing, chain-link with placards, or high visible silt fence) to be utilized.

The native topsoil, natural vegetation, and existing trees shall be retained in an undisturbed state to the maximum extent practicable in accordance with BMP C101. Limiting site disturbance is the single most effective method for reducing erosion. If it is not practicable to retain the native topsoil in place, it should be stockpiled on-site, covered to prevent erosion, and replaced immediately upon completion of the ground disturbing activities. The Contractor shall determine if construction is not possible due to presence of vegetation/tree, and shall clear, grub, and dispose of accordingly.

Installation Schedule: Spring 2022

Inspection and Maintenance Plan:

- If the fencing or clearing limits are observed to be damaged or visibility is reduced, it shall be repaired and/or replaced immediately and visibility restored.
- Fence or clearly mark areas around trees that are to be saved at least to the extents of the dripline.
- If tree roots are exposed or injured, prune cleanly with an appropriate pruning saw or loppers directly above the damaged roots and re-cover with native soils.

Responsible Staff:

- Project CESCL

5.4 Element #2: Establish Construction Access

A stabilized construction access is required to reduce the amount of sediment transported onto paved roads outside the project site. The TESC Plan will utilize existing gravel and paved driveways for preliminary site clearing and earthwork activities. The entrance will be stabilized and improved with quarry spalls, as necessary. Eventually, the Contractor will construct an entrance at the location of the permanent entrance. This stabilized construction entrance shall be constructed with a quarry spall pad in accordance with the requirements of BMP C105.

If sediment is tracked off-site, public roads shall be cleaned thoroughly at the end of each day, or more frequently during wet weather. Sediment shall be removed from roads by shoveling or pickup sweeping and shall be transported to a controlled sediment disposal area. Street washing will be allowed only after sediment is removed. Should tracking of sediments off-site continue to occur, wheel washes may be needed in accordance with BMP C106.

Installation Schedule: Spring 2022

Inspection and Maintenance Plan:

- If sediment or quarry spalls are observed being tracked onto pavement, then alternative measures to keep the street free of sediment shall be used. This may include replacement/cleaning of existing quarry spalls, street sweeping, an increase in the dimensions of the entrance, or the installation of a wheel wash.
- If a wheel wash is installed, the wheel wash should start out the day with fresh water, and the wash water should be changed a minimum once per day. The Contractor shall determine the frequency of changing the wash water.
- Inspect stabilized areas regularly, especially after large storm events. Crushed rock, gravel base, etc. shall be added as required to maintain a stable driving surface and to stabilize areas that have eroded.

Following temporary use, these areas shall be restored to pre-construction conditions or improved to limit.

Responsible Staff:

- Project CESCL

5.5 Element #3: Control Flow Rates

Stormwater runoff shall be observed during storm events to ensure flow rates are not increased to cause erosion to off-site locations. Straw wattles may be placed along slopes to reduce runoff velocity and distribute flow from channelized paths. Wattles may be intermittently spaced depending on slope steepness in accordance with BMP C225. Additionally, sediment traps will be constructed in accordance with BMP C240 as part of preliminary underground storm chamber excavation to collect sediment laden runoff. The sediment trap is effective at removing medium silt sized debris and must utilize additional BMPs to effectively remove sediment from the runoff. Additionally, at discharge locations from the sediment trap, outlet protection must be installed to prevent scouring to minimize downstream erosion from concentrated stormwater flows.

The proposed sediment trap is designed to manage flowrates from construction stormwater runoff. Inflow flowrates were determined by the post development 2-year event from WWHM modeling per Ecology design specifications. Post development flowrates ($Q_{2\text{-Year}}$) of 2.62 cfs require as a sediment to

be constructed with a minimum surface area of 5,450 SF at the invert elevation of the overflow weirs. Six separate weir outlets will be constructed to distribute any discharges from the sediment trap, and these discharges will outfall across existing vegetated areas. The contractor will stabilize any areas where exposed soils occur at outlet locations.

Installation Schedule: Spring/Summer 2022

Inspection and Maintenance Plan:

- Wattles may require maintenance to ensure they are in contact with the soil and thoroughly entrenched, especially following significant rainfall events.
- Inspect slopes after rainfall events and repair any areas where wattles are not tightly abutted or water has scoured beneath the wattles.
- If a temporary sediment pond is utilized, the sediment collected shall be removed from the pond when it reaches 1-foot in depth.
- Any damage to the temporary sediment trap embankments or slopes shall be repaired.

Responsible Staff:

- Project CESCL

5.6 Element #4: Install Sediment Controls

To minimize the discharge of pollutants offsite, erosion and sediment controls will be installed along site perimeter. Stormwater runoff from disturbed areas shall be routed through an appropriate sediment removal BMP per the Contractor's best judgement prior to runoff discharging off-site. Sediment laden runoff with high concentration shall be routed through a sediment pond prior to discharging offsite. Where feasible, direct stormwater to vegetated areas to increase sediment removal and maximize stormwater infiltration.

Runoff from fully stabilized areas may be discharged without a sediment removal BMP but must ensure downstream waterways are protected from erosion due to increases in the volume, velocity, and peak flow rate of stormwater from the project site. Silt fence barriers shall be constructed in accordance with BMP C233.

In addition to silt fencing, the following BMPs may be implemented where appropriate:

- BMP C230 – Straw Bale Barrier
- BMP C231 – Brusher Barrier
- BMP C232 – Gravel Filter Berm
- BMP C234 – Vegetated Strip
- BMP C235 – Straw Wattles
- BMP C240 – Sediment Trap
- BMP C241 – Temporary Sediment Pond
- BMP C 251 – Construction Stormwater Filtration

Installation Schedule: Spring/Summer 2022

Inspection and Maintenance Plan:

- Repair any damage immediately.
- Intercept and convey all evident concentrated flows uphill of the silt fence to a sediment pond.

- Remove sediment deposits when the deposit reaches approximately one-third of the height of the silt fence or install a second silt fence.
- Replace filter fabric that has deteriorated due to ultraviolet breakdown.

Responsible Staff:

- Project CESCL

5.7 Element #5: Stabilize Soils

All exposed and unworked soils shall be stabilized by application of effective BMPs, which protect the soil from the erosive forces of raindrop impact, flowing water, and from wind erosion. Clearing and grubbing schedule phasing shall be planned to reduce the amount of soil exposed during construction activity.

From October 1 through April 30, no soils shall remain exposed and un-worked for more than 2 days. From May 1 to September 30, no soils shall remain exposed and un-worked for more than 7 days. This condition applies to all soils on-site, whether at final grade or not. Soils to be stabilized at the end of shifts prior to holidays or weekends based on weather forecasts per Contractor's best judgement.

In areas where the soils will remain un-worked for more than 30 days or have reached final grade, seeding and mulching shall be used in accordance with BMPs C120 and C121. If the soil stockpile slope is 2H:1V or greater with at least 10 feet of vertical relief, nets, or blankets shall be used according to BMP C122. Sod shall be used in accordance with BMP C124 for disturbed areas that require immediate vegetative cover. Dust control shall be used as needed to prevent wind transport of dust from disturbed soil surfaces and in accordance with BMP C140. Contractor to utilize available non-potable water from on-site sources or provide water tanker in order to spray down disturbed soils to minimize dust produced from construction activities.

In addition, the following BMPs may be used to stabilize soils where appropriate:

- BMP C123 – Plastic Covering
- BMP C125 – Topsoiling
- BMP C130 – Surface Roughening
- BMP C131 – Gradient Terraces

Installation Schedule: Summer/Fall 2022

Inspection and Maintenance Plan:

- Reseed any seeded areas that fail to establish at least 80 percent cover. If reseeding is ineffective, use an alternative method such as sodding, mulching, or nets/blankets to stabilize soils.
- Reseed and protect by mulch any areas that experience erosion after achieving adequate cover.
- Supply seeded areas with adequate moisture, but do not water to the extent that runoff is generated.
- If the grass is unhealthy, the cause shall be determined and appropriate action taken to reestablish a healthy groundcover. If it is impossible to establish a healthy groundcover due to frequent saturation, instability, or some other cause, the sod shall be removed, the area seeded with an appropriate mix, and protected with a net or blanket.
- Respray areas as needed to keep dust to a minimum.

Responsible Staff:

- Project CESCL

5.8 Element #6: Protect Slopes

Slopes on disturbed areas will be stabilized as indicated in Element #5 as soon as feasible in the construction sequence. . Stabilizing these slopes will be critical in reducing erosion concerns and ensuring long-term stabilization of the slope. Applicable practices include, but are not limited to, reducing continuous length of slope with terracing and diversion, roughening slope surfaces, reducing slope surfaces.

Off-site stormwater shall be managed separately from stormwater generated on-site by diverting off-site run-on away from disturbed slopes with interceptor dikes or swales. Check dams will be placed at regular intervals if channels are constructed. A combination of BMPs is the most effective method to ensure protecting slopes with disturbed slopes. The following BMPs may be implemented where appropriate:

- BMP C200 – Interceptor Dike and Swale
- BMP C205 – Subsurface Drains
- BMP C206 – Level Spreader
- BMP C207 – Check Dams

Installation Schedule: Summer/Fall 2022

Inspection and Maintenance Plan:

- BMPs to be inspected after every runoff event to ensure that they are functioning correctly.

Responsible Staff:

- Project CESCL

5.9 Element #7: Protect Drain Inlets

All storm drain inlets made operable during construction, as well as all existing structures within the project limits, shall be marked and protected so that stormwater runoff shall not enter the conveyance system without first being filtered or treated to remove sediment. Install catch basin sock filters or approved equal as shown on the TESC Plans and in accordance with BMP C220 or WSDOT standard I-40.20-00.

Contractor to prevent sediment and street wash water to enter storm drains without prior and adequate treatment.

Installation Schedule: Summer/Fall 2022

Inspection and Maintenance Plan:

- Inlets to be inspected weekly at a minimum and daily during storm events.
- Inlet protection devices shall be cleaned and removed and replaced when sediment has filled one-third of the available storage (unless a different standard is specified by the product manufacturer).
- Do not wash sediment into storm drains while cleaning.

Responsible Staff:

- Project CESCL

5.10 Element #8: Stabilize Channels and Outlets

There are no observed channels or outlets in the existing site.

If the Contractor determines in the field that it is appropriate to construct temporary drainage swales to convey runoff to approved stormwater control facilities, the temporary drainage swales will provide stabilization, including armoring material, adequate to prevent erosion of outlets, slopes, and downstream reaches. The Contractor to contact Design Engineer for appropriate dimensions of conveyance channels if utilized.

Installation Schedule: Summer/Fall 2022

Inspection and Maintenance Plan:

- Inspect and repair as needed.
- Replace and increase riprap pad as discharge velocities are observed.
- Install check dams if concentrated flow rates are observed during and after a runoff event.

Responsible Staff:

- Project CESCL

5.11 Element #9: Control Pollutants

All pollutants, including waste materials and demolition debris, that occur on-site during construction shall be handled and disposed of in a manner that does not cause contamination of stormwater. Maintenance and repair of heavy equipment and vehicles involving oil changes, hydraulic system drain down, solvent, and de-greasing cleaning operations, fuel tank drain down and removal, and other activities which may result in discharge or spillage of pollutants to the ground or into stormwater runoff must be conducted using spill prevention measures, such as drip pans. Emergency repairs may be performed on-site using temporary plastic placed beneath, and if raining, over the vehicle. Application of agricultural chemicals, including fertilizers and pesticides, shall be conducted in a manner and at application rates that will not result in loss of chemical to stormwater runoff. Manufacturers' recommendations shall be followed for application rates and procedures. If a wheel wash is utilized, wastewater shall be treated by an on-site treatment system that prevents discharge to surface waters, sanitary sewers, or wetland areas. It may be combined with wastewater from concrete washout areas if properly disposed of at an off-site location or treatment facility.

Source control BMPs that will apply to this project include:

- A Spill Prevention Control and Countermeasures Plan (prepared by Contractor)
- Construction Stormwater Filtration
- Concrete Washout Area
- Street Sweeping (as needed during construction by Contractor)

Installation Schedule: Summer/Fall 2022

Inspection and Maintenance Plan:

- Contaminated surfaces shall be cleaned immediately following any discharge or spill incident.
- Source control BMPs shall be utilized to prevent the likelihood of pollutants being introduced on-site.

Responsible Staff:

- Project CESCL

5.12 Element #10: Control Dewatering

Groundwater was observed seeping into test pits at approximately 6-8.5-feet below ground surface attributed to seasonal groundwater.

It is not anticipated that dewatering will be required for this project. However, if dewatering is required, dewatering water is to be treated similar to on-site stormwater runoff. It must be conveyed through appropriate BMPs prior to off-site discharge. Refer to geotechnical recommendations for dewatering practices.

Installation Schedule: Summer/Fall 2022

Inspection and Maintenance Plan:

- Observe the turbidity of the dewatering water to determine the appropriate BMP and discharge location.

Responsible Staff:

- Project CESCL

5.13 Element #11: Maintain BMPs

All temporary and permanent erosion and sediment control BMPs shall be maintained and repaired as needed to ensure continued performance of their intended function. All maintenance and repair shall be in accordance with BMPs.

Sediment control BMPs shall be inspected weekly or after a runoff-producing storm event during the dry season and daily during the wet season.

All temporary erosion and sediment control BMPs shall be removed within 30 days after final site stabilization is achieved, or after the temporary BMPs are no longer needed. Trapped sediment shall be removed or stabilized on-site. Disturbed soil areas resulting from removal of BMPs or vegetation shall be permanently stabilized.

Installation Schedule: Summer/Fall 2022

Inspection and Maintenance Plan:

- Inspect BMPs at regular intervals, especially following large storm events.

Responsible Staff:

- Project CESCL

5.14 Element #12: Manage the Project

5.14.1 Phasing of Construction

The project shall be phased where feasible in order to prevent, to the maximum extent practicable, the transport of sediment from the site during construction. Revegetation of exposed areas and maintenance of that vegetation shall be an integral part of the clearing activities for each phase.

5.14.2 Seasonal Work Limitations

From October 1 through April 30, clearing, grading, and other soil disturbing activities shall only be permitted if silt-laden runoff will be prevented from leaving the construction site.

The following activities are exempt from the seasonal clearing and grading limitations:

- Routine maintenance and necessary repair of erosion and sediment control BMPs.
- Routine maintenance of public facilities or existing utility structures that do not expose the soil or result in the removal of the vegetative cover to the soil; and
- Activities where there is 100 percent infiltration of surface water runoff within the site in approved and installed erosion and sediment control facilities.

5.14.3 Inspection and Monitoring

All BMPs shall be inspected, maintained, and repaired as needed to ensure continued performance of their intended function.

Sampling and analysis of the stormwater discharges from the construction site may be necessary to ensure compliance with standards.

Whenever inspection and/or monitoring reveals that the BMPs identified in the construction SWPPP are inadequate, due to the actual discharge of or potential to discharge a significant amount of any pollutant, the construction SWPPP shall be modified, as appropriate, in a timely manner.

Site inspections shall be conducted the identified CESCL. The CESCL must be on-site or on-call at all times during the duration of construction activities. The CESCL must examine stormwater visually for the presence of suspended sediment, turbidity, discoloration, and oil sheen, and it is upon the CESCL's evaluation of the effectiveness of BMPs to determine if it is necessary to install, maintain, or repair BMPs to improve quality of stormwater discharges.

The CESCL must inspect all areas disturbed by construction activities, all BMPs, and all stormwater discharge points at least once every calendar week and within 24 hours of any discharge from the site. The CESCL may reduce this inspection frequency for temporary stabilized or inactive sites to once every calendar month through the duration of construction activities.

5.14.4 Maintenance of the SWPPP

The construction SWPPP shall be retained on-site or within reasonable access to the site. The construction SWPPP shall be modified by the Contractor and/or Engineer whenever there is a significant change in the design, construction, operation, or maintenance of any BMP.

The following BMPs may be implemented where appropriate:

- BMP C150 – Materials on Hand
- BMP C160 - Certified Erosion and Sediment Control Lead (CESCL)
- BMP C162 - Scheduling

Installation Schedule: Spring/Summer 2022

Inspection and Maintenance Plan:

- Inlets to be inspected weekly at a minimum and daily during storm events.

- Inlet protection devices shall be cleaned and removed and replaced when sediment has filled one-third of the available storage (unless a different standard is specified by the product manufacturer).
- Do not wash sediment into storm drains while cleaning.

Responsible Staff:

- CESCL: TBD

5.15 Element #13: Protect Low-Impact Development (LID) BMPs

To the maximum extent practical the team must control erosion and avoid introducing sediment to the infiltration planters and permanently stabilized bioorientation swale areas.

The project will not allow muddy construction equipment or sediment-laden runoff on the base material or pavement. All heavy equipment will be kept off existing soils under LID facilities.

The project will clean any infiltration area fouled with sediments or no longer passing an initial infiltration test.

Installation Schedule: Spring/Summer 2022

Inspection and Maintenance Plan:

- Inlets to be inspected weekly at a minimum and daily during storm events.
- Inlet protection devices shall be cleaned and removed and replaced when sediment has filled one-third of the available storage (unless a different standard is specified by the product manufacturer).
- Do not wash sediment into storm drains while cleaning.

Responsible Staff:

- CESCL: TBD

6. ESTIMATED CONSTRUCTION SCHEDULE

Construction Activity	Date of Completion
Project Start	Spring/Summer 2022
Install Erosion and Sediment Control BMPs	Spring/Summer 2022
Clearing and Demolition Begin	Spring/Summer 2022
Final Stabilization	Fall 2022
Remove Erosion and Sediment Control BMPs	Fall 2022
Project End	Fall 2022

7. REPORTING AND RECORD KEEPING

7.1 Record Keeping

7.1.1 Site Logbook

A site logbook will be maintained for all on-site construction activities and will include:

- A record of the implementation of the SWPPP and other permit requirements
- Site Inspections
- Sample Logs

7.1.2 Records Retention

Records will be retained during the life of the project and for a minimum of 3 years following the termination of permit coverage in accordance with Special Condition S5.C of the CSWGP.

Permit documentation to be retained on-site:

- CSWGP
- Permit Coverage Letter
- SWPPP
- Site Logbook

Permit documentation will be provided within 14 days of receipt of a written request from Ecology. A copy of the SWPPP or access to the SWPPP will be provided to the public when requested in writing accordance with Special Condition S5.G.2.b of the CSWGP.

7.1.3 Updating the SWPPP

The SWPPP will be modified if:

- Found ineffective in eliminating or significantly minimizing pollutants in stormwater discharges from the site.
- There is a change in design, construction, operation, or maintenance at the construction site that has, or could have, a significant effect on the discharge of pollutants to waters of the State.

The SWPPP will be modified within 7 days if inspections or investigations determine additional or modified BMPs are necessary for compliance. An updated timeline for BMP implementation will be prepared.

7.2 Reporting

7.2.1 Discharge Monitoring Reports

Discharge Monitoring Reports (DMRs) will be submitted to Ecology monthly. If there was no discharge during a given monitoring period the DMR will be submitted as required, reporting “No Discharge”. The DMR due date is fifteen (15) days following the end of each calendar month.

DMRs will be reported online through Ecology’s WQWebDMR System.

7.2.2 Notification of Noncompliance

If any of the terms and conditions of the permit is not met, and the resulting noncompliance may cause a threat to human health or the environment, the following actions will be taken:

1. Ecology will be notified within 24-hours of the failure to comply by calling the applicable Regional office ERTS phone number (Regional office numbers listed below).
2. Immediate action will be taken to prevent the discharge/pollution or otherwise stop or correct the noncompliance. If applicable, sampling and analysis of any noncompliance will be repeated immediately and the results submitted to Ecology within five (5) days of becoming aware of the violation.
3. A detailed written report describing the noncompliance will be submitted to Ecology within five (5) days, unless requested earlier by Ecology.

Anytime turbidity sampling indicates turbidity is 250 NTUs or greater, or water transparency is 6 cm or less, the Ecology Regional office will be notified by phone within 24 hours of analysis as required by Special Condition S5.A of the CSWGP.

- Central Region at (509) 575-2490 for Benton, Chelan, Douglas, Kittitas, Klickitat, Okanogan, or Yakima County
- Eastern Region at (509) 329-3400 for Adams, Asotin, Columbia, Ferry, Franklin, Garfield, Grant, Lincoln, Pend Oreille, Spokane, Stevens, Walla Walla, or Whitman County
- Northwest Region at (425) 649-7000 for Island, King, Kitsap, San Juan, Skagit, Snohomish, or Whatcom County
- Southwest Region at (360) 407-6300 for Clallam, Clark, Cowlitz, Grays Harbor, Jefferson, Lewis, Mason, Pacific, Pierce, Skamania, Thurston, or Wahkiakum

Include the following information:

1. Your name and / Phone number
2. Permit number
3. City / County of project
4. Sample results
5. Date / Time of call
6. Date / Time of sample
7. Project name

In accordance with Special Condition S4.D.5.b of the CSWGP, the Ecology Regional office will be notified if chemical treatment other than CO₂ sparging is planned for adjustment of high pH water.

8. SITE PLAN

Refer to the Civil Plans and the Contractor's TESC plans submitted for this project for site location, project boundary, stormwater discharge, and erosion control plan.

Erosion and Sediment Control BMPs

4.1 Source Control BMPs

BMP C101: Preserving Natural Vegetation

Purpose

The purpose of preserving natural vegetation is to reduce erosion wherever practicable. Limiting site disturbance is the single most effective method for reducing erosion. For example, conifers can hold up to about 50 percent of all rain that falls during a storm. Up to 20-30 percent of this rain may never reach the ground but is taken up by the tree or evaporates. Another benefit is that the rain held in the tree can be released slowly to the ground after the storm.

Conditions of Use

- Natural vegetation should be preserved on steep slopes, near perennial and intermittent watercourses or swales, and on building sites in wooded areas.
- As required by local governments.

Design and Installation Specifications

Natural vegetation can be preserved in natural clumps or as individual trees, shrubs and vines.

The preservation of individual plants is more difficult because heavy equipment is generally used to remove unwanted vegetation. The points to remember when attempting to save individual plants are:

- Is the plant worth saving? Consider the location, species, size, age, vigor, and the work involved. Local governments may also have ordinances to save natural vegetation and trees.
- Fence or clearly mark areas around trees that are to be saved. It is preferable to keep ground disturbance away from the trees at least as far out as the dripline.

Plants need protection from three kinds of injuries:

- *Construction Equipment* - This injury can be above or below the ground level. Damage results from scarring, cutting of roots, and compaction of the soil. Placing a fenced buffer zone around plants to be saved prior to construction can prevent construction equipment injuries.
- *Grade Changes* - Changing the natural ground level will alter grades, which affects the plant's ability to obtain the necessary air, water, and minerals. Minor fills usually do not cause problems although sensitivity between species does vary and should be checked. Trees can tolerate fill of 6 inches or less. For shrubs and other plants, the fill should be less.

When there are major changes in grade, it may become necessary to supply air to the roots of plants. This can be done by placing a layer of gravel and a tile system over the roots before the fill is made. A tile

system protects a tree from a raised grade. The tile system should be laid out on the original grade leading from a dry well around the tree trunk. The system should then be covered with small stones to allow air to circulate over the root area.

Lowering the natural ground level can seriously damage trees and shrubs. The highest percentage of the plant roots are in the upper 12 inches of the soil and cuts of only 2-3 inches can cause serious injury. To protect the roots it may be necessary to terrace the immediate area around the plants to be saved. If roots are exposed, construction of retaining walls may be needed to keep the soil in place. Plants can also be preserved by leaving them on an undisturbed, gently sloping mound. To increase the chances for survival, it is best to limit grade changes and other soil disturbances to areas outside the dripline of the plant.

- *Excavations* - Protect trees and other plants when excavating for drainfields, power, water, and sewer lines. Where possible, the trenches should be routed around trees and large shrubs. When this is not possible, it is best to tunnel under them. This can be done with hand tools or with power augers. If it is not possible to route the trench around plants to be saved, then the following should be observed:

Cut as few roots as possible. When you have to cut, cut clean. Paint cut root ends with a wood dressing like asphalt base paint.

Backfill the trench as soon as possible.

Tunnel beneath root systems as close to the center of the main trunk to preserve most of the important feeder roots.

Some problems that can be encountered with a few specific trees are:

- Maple, Dogwood, Red alder, Western hemlock, Western red cedar, and Douglas fir do not readily adjust to changes in environment and special care should be taken to protect these trees.
- The windthrow hazard of Pacific silver fir and madronna is high, while that of Western hemlock is moderate. The danger of windthrow increases where dense stands have been thinned. Other species (unless they are on shallow, wet soils less than 20 inches deep) have a low windthrow hazard.
- Cottonwoods, maples, and willows have water-seeking roots. These can cause trouble in sewer lines and infiltration fields. On the other hand, they thrive in high moisture conditions that other trees would not.
- Thinning operations in pure or mixed stands of Grand fir, Pacific silver fir, Noble fir, Sitka spruce, Western red cedar, Western hemlock,

Pacific dogwood, and Red alder can cause serious disease problems. Disease can become established through damaged limbs, trunks, roots, and freshly cut stumps. Diseased and weakened trees are also susceptible to insect attack.

***Maintenance
Standards***

- Inspect flagged and/or fenced areas regularly to make sure flagging or fencing has not been removed or damaged. If the flagging or fencing has been damaged or visibility reduced, it shall be repaired or replaced immediately and visibility restored.
- If tree roots have been exposed or injured, “prune” cleanly with an appropriate pruning saw or loppers directly above the damaged roots and recover with native soils. Treatment of sap flowing trees (fir, hemlock, pine, soft maples) is not advised as sap forms a natural healing barrier.

BMP C103: High Visibility Plastic or Metal Fence

Purpose Fencing is intended to: (1) restrict clearing to approved limits; (2) prevent disturbance of sensitive areas, their buffers, and other areas required to be left undisturbed; (3) limit construction traffic to designated construction entrances or roads; and, (4) protect areas where marking with survey tape may not provide adequate protection.

Conditions of Use To establish clearing limits, plastic or metal fence may be used:

- At the boundary of sensitive areas, their buffers, and other areas required to be left uncleared.
- As necessary to control vehicle access to and on the site.

***Design and
Installation
Specifications***

- High visibility plastic fence shall be composed of a high-density polyethylene material and shall be at least four feet in height. Posts for the fencing shall be steel or wood and placed every 6 feet on center (maximum) or as needed to ensure rigidity. The fencing shall be fastened to the post every six inches with a polyethylene tie. On long continuous lengths of fencing, a tension wire or rope shall be used as a top stringer to prevent sagging between posts. The fence color shall be high visibility orange. The fence tensile strength shall be 360 lbs./ft. using the ASTM D4595 testing method.
- Metal fences shall be designed and installed according to the manufacturer's specifications.
- Metal fences shall be at least 3 feet high and must be highly visible.
- Fences shall not be wired or stapled to trees.

***Maintenance
Standards***

- If the fence has been damaged or visibility reduced, it shall be repaired or replaced immediately and visibility restored.

BMP C105: Stabilized Construction Entrance

Purpose Construction entrances are stabilized to reduce the amount of sediment transported onto paved roads by vehicles or equipment by constructing a stabilized pad of quarry spalls at entrances to construction sites.

Conditions of Use Construction entrances shall be stabilized wherever traffic will be leaving a construction site and traveling on paved roads or other paved areas within 1,000 feet of the site.

On large commercial, highway, and road projects, the designer should include enough extra materials in the contract to allow for additional stabilized entrances not shown in the initial Construction SWPPP. It is difficult to determine exactly where access to these projects will take place; additional materials will enable the contractor to install them where needed.

Design and Installation Specifications

- See Figure 4.2 for details. Note: the 100' minimum length of the entrance shall be reduced to the maximum practicable size when the size or configuration of the site does not allow the full length (100').
- A separation geotextile shall be placed under the spalls to prevent fine sediment from pumping up into the rock pad. The geotextile shall meet the following standards:

Grab Tensile Strength (ASTM D4751)	200 psi min.
Grab Tensile Elongation (ASTM D4632)	30% max.
Mullen Burst Strength (ASTM D3786-80a)	400 psi min.
AOS (ASTM D4751)	20-45 (U.S. standard sieve size)

- Consider early installation of the first lift of asphalt in areas that will paved; this can be used as a stabilized entrance. Also consider the installation of excess concrete as a stabilized entrance. During large concrete pours, excess concrete is often available for this purpose.
- Hog fuel (wood-based mulch) may be substituted for or combined with quarry spalls in areas that will not be used for permanent roads. Hog fuel is generally less effective at stabilizing construction entrances and should be used only at sites where the amount of traffic is very limited. Hog fuel is not recommended for entrance stabilization in urban areas. The effectiveness of hog fuel is highly variable and it generally requires more maintenance than quarry spalls. The inspector may at any time require the use of quarry spalls if the hog fuel is not preventing sediment from being tracked onto pavement or if the hog fuel is being carried onto pavement. Hog fuel is prohibited in permanent roadbeds because organics in the subgrade soils cause degradation of the subgrade support over time.
- Fencing (see BMPs C103 and C104) shall be installed as necessary to restrict traffic to the construction entrance.

Maintenance Standards

- Whenever possible, the entrance shall be constructed on a firm, compacted subgrade. This can substantially increase the effectiveness of the pad and reduce the need for maintenance.
- Quarry spalls (or hog fuel) shall be added if the pad is no longer in accordance with the specifications.
- If the entrance is not preventing sediment from being tracked onto pavement, then alternative measures to keep the streets free of sediment shall be used. This may include street sweeping, an increase in the dimensions of the entrance, or the installation of a wheel wash.
- Any sediment that is tracked onto pavement shall be removed by shoveling or street sweeping. The sediment collected by sweeping shall be removed or stabilized on site. The pavement shall not be cleaned by washing down the street, except when sweeping is ineffective and there is a threat to public safety. If it is necessary to wash the streets, the construction of a small sump shall be considered. The sediment would then be washed into the sump where it can be controlled.
- Any quarry spalls that are loosened from the pad, which end up on the roadway shall be removed immediately.
- If vehicles are entering or exiting the site at points other than the construction entrance(s), fencing (see BMPs C103 and C104) shall be installed to control traffic.
- Upon project completion and site stabilization, all construction accesses intended as permanent access for maintenance shall be permanently stabilized.

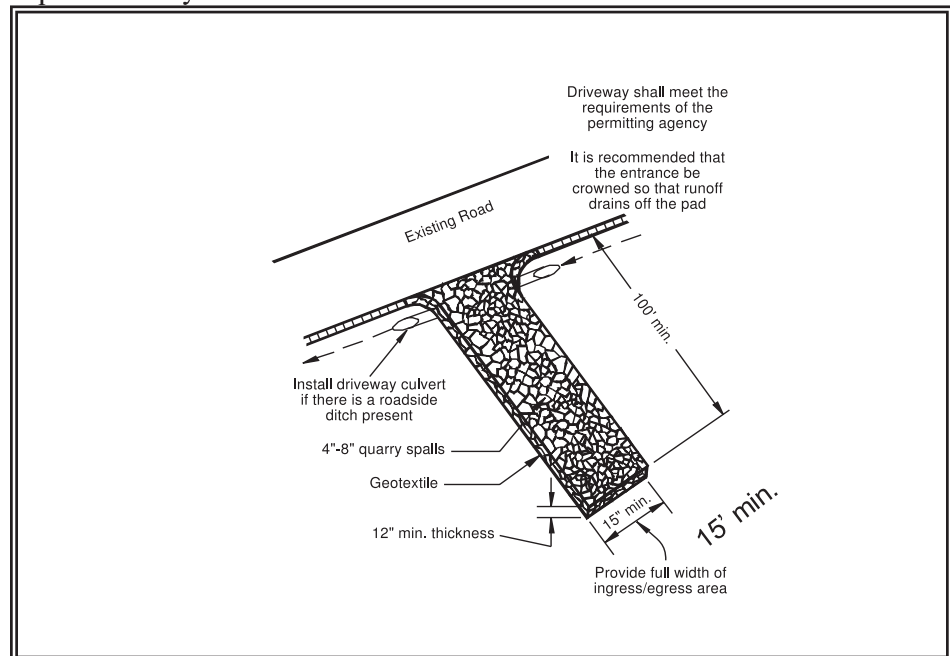

Figure 4.2 – Stabilized Construction Entrance

BMP C106: Wheel Wash

Purpose

Wheel washes reduce the amount of sediment transported onto paved roads by motor vehicles.

Conditions of Use

When a stabilized construction entrance (see BMP C105) is not preventing sediment from being tracked onto pavement.

- Wheel washing is generally an effective BMP when installed with careful attention to topography. For example, a wheel wash can be detrimental if installed at the top of a slope abutting a right-of-way where the water from the dripping truck can run unimpeded into the street.
- Pressure washing combined with an adequately sized and surfaced pad with direct drainage to a large 10-foot x 10-foot sump can be very effective.

Design and Installation Specifications

Suggested details are shown in Figure 4.3. The Local Permitting Authority may allow other designs. A minimum of 6 inches of asphalt treated base (ATB) over crushed base material or 8 inches over a good subgrade is recommended to pave the wheel wash.

Use a low clearance truck to test the wheel wash before paving. Either a belly dump or lowboy will work well to test clearance.

Keep the water level from 12 to 14 inches deep to avoid damage to truck hubs and filling the truck tongues with water.

Midpoint spray nozzles are only needed in extremely muddy conditions.

Wheel wash systems should be designed with a small grade change, 6 to 12 inches for a 10-foot-wide pond, to allow sediment to flow to the low side of pond to help prevent re-suspension of sediment. A drainpipe with a 2- to 3-foot riser should be installed on the low side of the pond to allow for easy cleaning and refilling. Polymers may be used to promote coagulation and flocculation in a closed-loop system. Polyacrylamide (PAM) added to the wheel wash water at a rate of 0.25 - 0.5 pounds per 1,000 gallons of water increases effectiveness and reduces cleanup time. If PAM is already being used for dust or erosion control and is being applied by a water truck, the same truck can be used to change the wash water.

Maintenance Standards

The wheel wash should start out the day with fresh water.

The wash water should be changed a minimum of once per day. On large earthwork jobs where more than 10-20 trucks per hour are expected, the wash water will need to be changed more often.

Wheel wash or tire bath wastewater shall be discharged to a separate on-site treatment system, such as closed-loop recirculation or land application, or to the sanitary sewer with proper local sewer district approval.

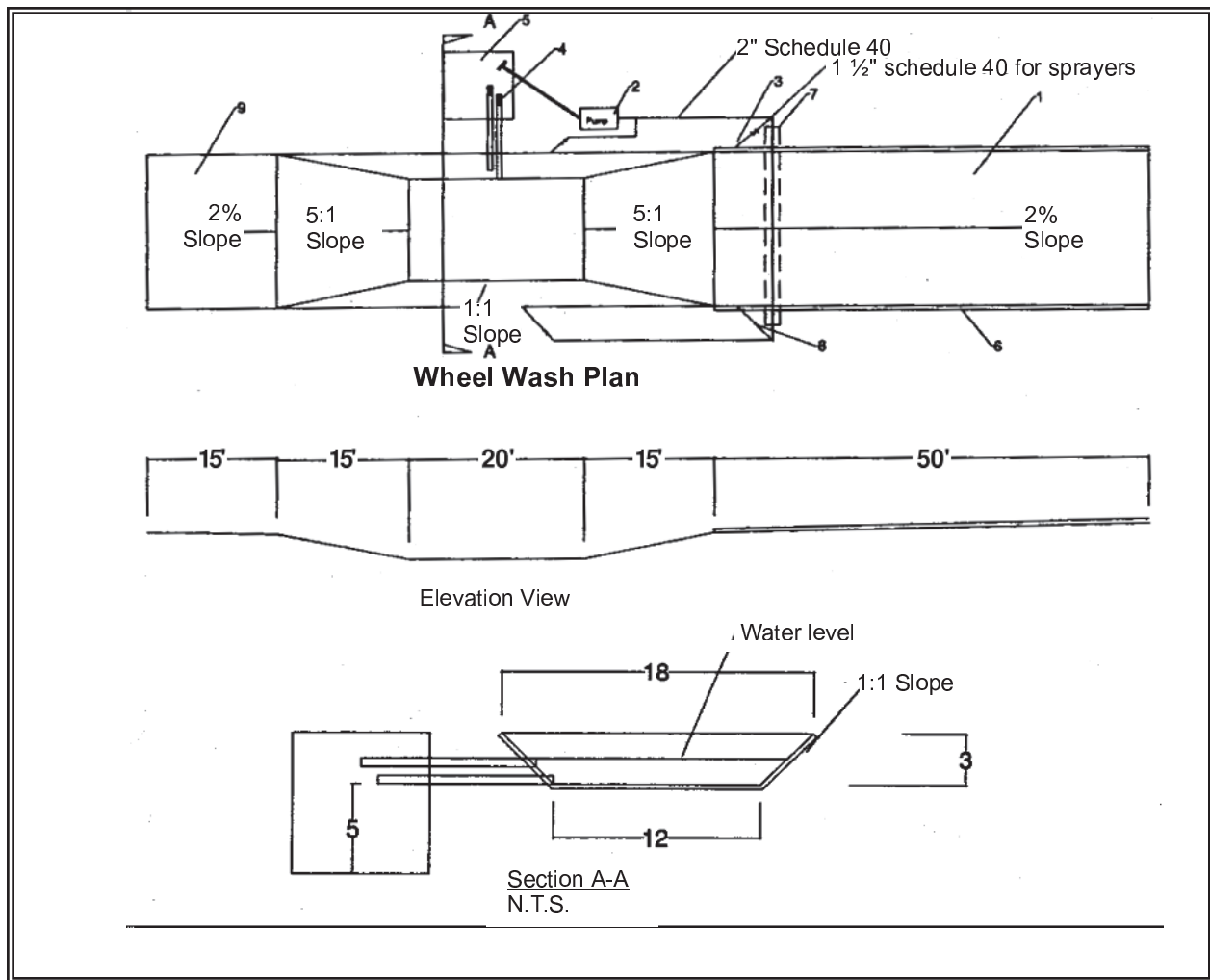

Figure 4.3 Wheel Wash

Notes:

1. Asphalt construction entrance 6 in. asphalt treated base (ATB).
2. 3-inch trash pump with floats on the suction hose.
3. Midpoint spray nozzles, if needed.
4. 6-inch sewer pipe with butterfly valves. Bottom one is a drain. Locate top pipe's invert 1 foot above bottom of wheel wash.
5. 8 foot x 8 foot sump with 5 feet of catch. Build so can be cleaned with trackhoe.
6. Asphalt curb on the low road side to direct water back to pond.
7. 6-inch sleeve under road.
8. Ball valves.
9. 15 foot. ATB apron to protect ground from splashing water.

BMP C107: Construction Road/Parking Area Stabilization

<i>Purpose</i>	Stabilizing subdivision roads, parking areas, and other onsite vehicle transportation routes immediately after grading reduces erosion caused by construction traffic or runoff.
<i>Conditions of Use</i>	<ul style="list-style-type: none">• Roads or parking areas shall be stabilized wherever they are constructed, whether permanent or temporary, for use by construction traffic.• Fencing (see BMPs C103 and C104) shall be installed, if necessary, to limit the access of vehicles to only those roads and parking areas that are stabilized.
<i>Design and Installation Specifications</i>	<ul style="list-style-type: none">• On areas that will receive asphalt as part of the project, install the first lift as soon as possible.• A 6-inch depth of 2- to 4-inch crushed rock, gravel base, or crushed surfacing base course shall be applied immediately after grading or utility installation. A 4-inch course of asphalt treated base (ATB) may also be used, or the road/parking area may be paved. It may also be possible to use cement or calcium chloride for soil stabilization. If cement or cement kiln dust is used for roadbase stabilization, pH monitoring and BMPs are necessary to evaluate and minimize the effects on stormwater. If the area will not be used for permanent roads, parking areas, or structures, a 6-inch depth of hog fuel may also be used, but this is likely to require more maintenance. Whenever possible, construction roads and parking areas shall be placed on a firm, compacted subgrade.• Temporary road gradients shall not exceed 15 percent. Roadways shall be carefully graded to drain. Drainage ditches shall be provided on each side of the roadway in the case of a crowned section, or on one side in the case of a super-elevated section. Drainage ditches shall be directed to a sediment control BMP.• Rather than relying on ditches, it may also be possible to grade the road so that runoff sheet-flows into a heavily vegetated area with a well-developed topsoil. Landscaped areas are not adequate. If this area has at least 50 feet of vegetation, then it is generally preferable to use the vegetation to treat runoff, rather than a sediment pond or trap. The 50 feet shall not include wetlands. If runoff is allowed to sheetflow through adjacent vegetated areas, it is vital to design the roadways and parking areas so that no concentrated runoff is created.• Storm drain inlets shall be protected to prevent sediment-laden water entering the storm drain system (see BMP C220).
<i>Maintenance Standards</i>	<ul style="list-style-type: none">• Inspect stabilized areas regularly, especially after large storm events.• Crushed rock, gravel base, hog fuel, etc. shall be added as required to maintain a stable driving surface and to stabilize any areas that have eroded.• Following construction, these areas shall be restored to pre-construction condition or better to prevent future erosion.

BMP C120: Temporary and Permanent Seeding

Purpose

Seeding is intended to reduce erosion by stabilizing exposed soils. A well-established vegetative cover is one of the most effective methods of reducing erosion.

Conditions of Use

- Seeding may be used throughout the project on disturbed areas that have reached final grade or that will remain unworked for more than 30 days.
- Channels that will be vegetated should be installed before major earthwork and hydroseeded with a Bonded Fiber Matrix. The vegetation should be well established (i.e., 75 percent cover) before water is allowed to flow in the ditch. With channels that will have high flows, erosion control blankets should be installed over the hydroseed. If vegetation cannot be established from seed before water is allowed in the ditch, sod should be installed in the bottom of the ditch over hydromulch and blankets.
- Retention/detention ponds should be seeded as required.
- Mulch is required at all times because it protects seeds from heat, moisture loss, and transport due to runoff.
- All disturbed areas shall be reviewed in late August to early September and all seeding should be completed by the end of September. Otherwise, vegetation will not establish itself enough to provide more than average protection.
- At final site stabilization, all disturbed areas not otherwise vegetated or stabilized shall be seeded and mulched. Final stabilization means the completion of all soil disturbing activities at the site and the establishment of a permanent vegetative cover, or equivalent permanent stabilization measures (such as pavement, riprap, gabions or geotextiles) which will prevent erosion.
- Seeding should be done during those seasons most conducive to growth and will vary with the climate conditions of the region. Local experience should be used to determine the appropriate seeding periods.
- The optimum seeding windows for western Washington are April 1 through June 30 and September 1 through October 1. Seeding that occurs between July 1 and August 30 will require irrigation until 75 percent grass cover is established. Seeding that occurs between October 1 and March 30 will require a mulch or plastic cover until 75 percent grass cover is established.
- To prevent seed from being washed away, confirm that all required surface water control measures have been installed.

Design and Installation Specifications

- The seedbed should be firm and rough. All soil should be roughened no matter what the slope. If compaction is required for engineering purposes, slopes must be track walked before seeding. Backblading or smoothing of slopes greater than 4:1 is not allowed if they are to be seeded.
- New and more effective restoration-based landscape practices rely on deeper incorporation than that provided by a simple single-pass rototilling treatment. Wherever practical the subgrade should be initially ripped to improve long-term permeability, infiltration, and water inflow qualities. At a minimum, permanent areas shall use soil amendments to achieve organic matter and permeability performance defined in engineered soil/landscape systems. For systems that are deeper than 8 inches the rototilling process should be done in multiple lifts, or the prepared soil system shall be prepared properly and then placed to achieve the specified depth.
- Organic matter is the most appropriate form of “fertilizer” because it provides nutrients (including nitrogen, phosphorus, and potassium) in the least water-soluble form. A natural system typically releases 2-10 percent of its nutrients annually. Chemical fertilizers have since been formulated to simulate what organic matter does naturally.
- In general, 10-4-6 N-P-K (nitrogen-phosphorus-potassium) fertilizer can be used at a rate of 90 pounds per acre. Slow-release fertilizers should always be used because they are more efficient and have fewer environmental impacts. It is recommended that areas being seeded for final landscaping conduct soil tests to determine the exact type and quantity of fertilizer needed. This will prevent the over-application of fertilizer. Fertilizer should not be added to the hydromulch machine and agitated more than 20 minutes before it is to be used. If agitated too much, the slow-release coating is destroyed.
- There are numerous products available on the market that take the place of chemical fertilizers. These include several with seaweed extracts that are beneficial to soil microbes and organisms. If 100 percent cottonseed meal is used as the mulch in hydroseed, chemical fertilizer may not be necessary. Cottonseed meal is a good source of long-term, slow-release, available nitrogen.
- Hydroseed applications shall include a minimum of 1,500 pounds per acre of mulch with 3 percent tackifier. Mulch may be made up of 100 percent: cottonseed meal; fibers made of wood, recycled cellulose, hemp, and kenaf; compost; or blends of these. Tackifier shall be plant-based, such as guar or alpha plantago, or chemical-based such as polyacrylamide or polymers. Any mulch or tackifier product used shall be installed per manufacturer’s instructions. Generally, mulches come in 40-50 pound bags. Seed and fertilizer are added at time of application.

- Mulch is always required for seeding. Mulch can be applied on top of the seed or simultaneously by hydroseeding.
- On steep slopes, Bonded Fiber Matrix (BFM) or Mechanically Bonded Fiber Matrix (MBFM) products should be used. BFM/MBFM products are applied at a minimum rate of 3,000 pounds per acre of mulch with approximately 10 percent tackifier. Application is made so that a minimum of 95 percent soil coverage is achieved. Numerous products are available commercially and should be installed per manufacturer's instructions. Most products require 24-36 hours to cure before a rainfall and cannot be installed on wet or saturated soils. Generally, these products come in 40-50 pound bags and include all necessary ingredients except for seed and fertilizer.

BFMs and MBFMs have some advantages over blankets:

- No surface preparation required;
- Can be installed via helicopter in remote areas;
- On slopes steeper than 2.5:1, blanket installers may need to be roped and harnessed for safety;
- They are at least \$1,000 per acre cheaper installed.

In most cases, the shear strength of blankets is not a factor when used on slopes, only when used in channels. BFMs and MBFMs are good alternatives to blankets in most situations where vegetation establishment is the goal.

- When installing seed via hydroseeding operations, only about 1/3 of the seed actually ends up in contact with the soil surface. This reduces the ability to establish a good stand of grass quickly. One way to overcome this is to increase seed quantities by up to 50 percent.
- Vegetation establishment can also be enhanced by dividing the hydromulch operation into two phases:
 1. Phase 1- Install all seed and fertilizer with 25-30 percent mulch and tackifier onto soil in the first lift;
 2. Phase 2- Install the rest of the mulch and tackifier over the first lift.

An alternative is to install the mulch, seed, fertilizer, and tackifier in one lift. Then, spread or blow straw over the top of the hydromulch at a rate of about 800-1000 pounds per acre. Hold straw in place with a standard tackifier. Both of these approaches will increase cost moderately but will greatly improve and enhance vegetative establishment. The increased cost may be offset by the reduced need for:

1. Irrigation
2. Reapplication of mulch
3. Repair of failed slope surfaces

This technique works with standard hydromulch (1,500 pounds per acre minimum) and BFM/MBFMs (3,000 pounds per acre minimum).

- Areas to be permanently landscaped shall provide a healthy topsoil that reduces the need for fertilizers, improves overall topsoil quality, provides for better vegetal health and vitality, improves hydrologic characteristics, and reduces the need for irrigation. This can be accomplished in a number of ways:

Recent research has shown that the best method to improve till soils is to amend these soils with compost. The optimum mixture is approximately two parts soil to one part compost. This equates to 4 inches of compost mixed to a depth of 12 inches in till soils. Increasing the concentration of compost beyond this level can have negative effects on vegetal health, while decreasing the concentrations can reduce the benefits of amended soils. Please note: The compost should meet specifications for Grade A quality compost in Ecology Publication 94-038.

Other soils, such as gravel or cobble outwash soils, may require different approaches. Organics and fines easily migrate through the loose structure of these soils. Therefore, the importation of at least 6 inches of quality topsoil, underlain by some type of filter fabric to prevent the migration of fines, may be more appropriate for these soils.

Areas that already have good topsoil, such as undisturbed areas, do not require soil amendments.

- Areas that will be seeded only and not landscaped may need compost or meal-based mulch included in the hydroseed in order to establish vegetation. Native topsoil should be re-installed on the disturbed soil surface before application.
- Seed that is installed as a temporary measure may be installed by hand if it will be covered by straw, mulch, or topsoil. Seed that is installed as a permanent measure may be installed by hand on small areas (usually less than 1 acre) that will be covered with mulch, topsoil, or erosion blankets. The seed mixes listed below include recommended mixes for both temporary and permanent seeding. These mixes, with the exception of the wetland mix, shall be applied at a rate of 120 pounds per acre. This rate can be reduced if soil amendments or slow-release fertilizers are used. Local suppliers or the local conservation district should be consulted for their recommendations because the appropriate mix depends on a variety of factors, including location, exposure, soil type, slope, and expected foot traffic. Alternative seed mixes approved by the local authority may be used.

Table 4.1 represents the standard mix for those areas where just a temporary vegetative cover is required.

Table 4.1 Temporary Erosion Control Seed Mix			
	% Weight	% Purity	% Germination
Chewings or annual blue grass <i>Festuca rubra var. commutata</i> or <i>Poa anna</i>	40	98	90
Perennial rye - <i>Lolium perenne</i>	50	98	90
Redtop or colonial bentgrass <i>Agrostis alba</i> or <i>Agrostis tenuis</i>	5	92	85
White dutch clover <i>Trifolium repens</i>	5	98	90

Table 4.2 provides just one recommended possibility for landscaping seed.

Table 4.2 Landscaping Seed Mix			
	% Weight	% Purity	% Germination
Perennial rye blend <i>Lolium perenne</i>	70	98	90
Chewings and red fescue blend <i>Festuca rubra var. commutata</i> or <i>Festuca rubra</i>	30	98	90

This turf seed mix in Table 4.3 is for dry situations where there is no need for much water. The advantage is that this mix requires very little maintenance.

Table 4.3 Low-Growing Turf Seed Mix			
	% Weight	% Purity	% Germination
Dwarf tall fescue (several varieties) <i>Festuca arundinacea var.</i>	45	98	90
Dwarf perennial rye (Barclay) <i>Lolium perenne var. barclay</i>	30	98	90
Red fescue <i>Festuca rubra</i>	20	98	90
Colonial bentgrass <i>Agrostis tenuis</i>	5	98	90

Table 4.4 presents a mix recommended for bioswales and other intermittently wet areas.

Table 4.4 Bioswale Seed Mix*			
	% Weight	% Purity	% Germination
Tall or meadow fescue <i>Festuca arundinacea</i> or <i>Festuca elatior</i>	75-80	98	90
Seaside/Creeping bentgrass <i>Agrostis palustris</i>	10-15	92	85
Redtop bentgrass <i>Agrostis alba</i> or <i>Agrostis gigantea</i>	5-10	90	80

* Modified Briargreen, Inc. Hydroseeding Guide Wetlands Seed Mix

The seed mix shown in Table 4.5 is a recommended low-growing, relatively non-invasive seed mix appropriate for very wet areas that are not regulated wetlands. Other mixes may be appropriate, depending on the soil type and hydrology of the area. Recent research suggests that bentgrass (agrostis sp.) should be emphasized in wet-area seed mixes. Apply this mixture at a rate of 60 pounds per acre.

Table 4.5 Wet Area Seed Mix*			
	% Weight	% Purity	% Germination
Tall or meadow fescue <i>Festuca arundinacea</i> or <i>Festuca elatior</i>	60-70	98	90
Seaside/Creeping bentgrass <i>Agrostis palustris</i>	10-15	98	85
Meadow foxtail <i>Alepcurus pratensis</i>	10-15	90	80
Alsike clover <i>Trifolium hybridum</i>	1-6	98	90
Redtop bentgrass <i>Agrostis alba</i>	1-6	92	85

* Modified Briargreen, Inc. Hydroseeding Guide Wetlands Seed Mix

The meadow seed mix in Table 4.6 is recommended for areas that will be maintained infrequently or not at all and where colonization by native plants is desirable. Likely applications include rural road and utility right-of-way. Seeding should take place in September or very early October in order to obtain adequate establishment prior to the winter months. The appropriateness of clover in the mix may need to be considered, as this can be a fairly invasive species. If the soil is amended, the addition of clover may not be necessary.

Table 4.6 Meadow Seed Mix			
	% Weight	% Purity	% Germination
Redtop or Oregon bentgrass <i>Agrostis alba</i> or <i>Agrostis oregonensis</i>	20	92	85
Red fescue <i>Festuca rubra</i>	70	98	90
White dutch clover <i>Trifolium repens</i>	10	98	90

Maintenance Standards

- Any seeded areas that fail to establish at least 80 percent cover (100 percent cover for areas that receive sheet or concentrated flows) shall be reseeded. If reseeding is ineffective, an alternate method, such as sodding, mulching, or nets/blankets, shall be used. If winter weather prevents adequate grass growth, this time limit may be relaxed at the discretion of the local authority when sensitive areas would otherwise be protected.

- After adequate cover is achieved, any areas that experience erosion shall be reseeded and protected by mulch. If the erosion problem is drainage related, the problem shall be fixed and the eroded area reseeded and protected by mulch.
- Seeded areas shall be supplied with adequate moisture, but not watered to the extent that it causes runoff.

BMP C121: Mulching

Purpose

Mulching soils provides immediate temporary protection from erosion. Mulch also enhances plant establishment by conserving moisture, holding fertilizer, seed, and topsoil in place, and moderating soil temperatures. There is an enormous variety of mulches that can be used. This section discusses only the most common types of mulch.

Conditions of Use

As a temporary cover measure, mulch should be used:

- For less than 30 days on disturbed areas that require cover.
- At all times for seeded areas, especially during the wet season and during the hot summer months.
- During the wet season on slopes steeper than 3H:1V with more than 10 feet of vertical relief.

Mulch may be applied at any time of the year and must be refreshed periodically.

- For seeded areas mulch may be made up of 100 percent: cottonseed meal; fibers made of wood, recycled cellulose, hemp, kenaf; compost; or blends of these. Tackifier shall be plant-based, such as guar or alpha plantago, or chemical-based such as polyacrylamide or polymers. Any mulch or tackifier product used shall be installed per manufacturer's instructions. Generally, mulches come in 40-50 pound bags. Seed and fertilizer are added at time of application.

Design and Installation Specifications

For mulch materials, application rates, and specifications, see [Table II-4.1.8 Mulch Standards and Guidelines](#). Always use a 2-inch minimum mulch thickness; increase the thickness until the ground is 95% covered (i.e. not visible under the mulch layer). Note: Thickness may be increased for disturbed areas in or near sensitive areas or other areas highly susceptible to erosion.

Where the option of "Compost" is selected, it should be a coarse compost that meets the following size gradations when tested in accordance with the U.S. Composting Council "Test Methods for the Examination of Compost and Composting" (TMECC) Test Method 02.02-B.

Coarse Compost

Minimum Percent passing 3" sieve openings 100%

Minimum Percent passing 1" sieve openings 90%

Minimum Percent passing ¾" sieve openings 70%

Minimum Percent passing ¼" sieve openings 40%

Mulch used within the ordinary high-water mark of surface waters should be selected to minimize potential flotation of organic matter. Composted organic materials have higher specific gravities (densities) than straw, wood, or chipped material. Consult Hydraulic Permit Authority (HPA) for mulch mixes if applicable.

Maintenance Standards

- The thickness of the cover must be maintained.
- Any areas that experience erosion shall be remulched and/or protected with a net or blanket. If the erosion problem is drainage related, then the problem shall be fixed and the eroded area remulched.

Table II-4.1.8 Mulch Standards and Guidelines

Mulch Material	Quality Standards	Application Rates	Remarks
Straw	Air-dried; free from undesirable seed and coarse material.	2"-3" thick; 5 bales per 1,000 sf or 2-3 tons per acre	Cost-effective protection when applied with adequate thickness. Hand-application generally requires greater thickness than blown straw. The thickness of straw may be reduced by half when used in conjunction with seeding. In windy areas straw must be held in place by crimping, using a tackifier, or covering with netting. Blown straw always has to be held in place with a tackifier as even light winds will blow it away. Straw, however, has several deficiencies that should be considered when selecting mulch materials. It often introduces and/or encourages the propagation of weed species and it has no significant long-term benefits. It should also not be used within the ordinary high-water elevation of surface waters (due to flotation).
Hydromulch	No growth inhibiting factors.	Approx. 25-30 lbs per 1,000 sf or 1,500 - 2,000 lbs per acre	Shall be applied with hydromulcher. Shall not be used without seed and tackifier unless the application rate is at least doubled. Fibers longer than about ¾ - 1 inch clog hydromulch equipment. Fibers should be kept to less than ¾ inch.

Mulch Material	Quality Standards	Application Rates	Remarks
Compost	No visible water or dust during handling. Must be produced per WAC 173-350, Solid Waste Handling Standards, but may have up to 35% biosolids.	2" thick min.; approx. 100 tons per acre (approx. 800 lbs per yard)	More effective control can be obtained by increasing thickness to 3". Excellent mulch for protecting final grades until landscaping because it can be directly seeded or tilled into soil as an amendment. Compost used for mulch has a coarser size gradation than compost used for BMP C125: Topsoiling / Composting or BMP T5.13: Post-Construction Soil Quality and Depth . It is more stable and practical to use in wet areas and during rainy weather conditions. Do not use near wetlands or near phosphorous impaired water bodies.
Chipped Site Vegetation	Average size shall be several inches. Gradations from fines to 6 inches in length for texture, variation, and interlocking properties.	2" thick min.;	This is a cost-effective way to dispose of debris from clearing and grubbing, and it eliminates the problems associated with burning. Generally, it should not be used on slopes above approx. 10% because of its tendency to be transported by runoff. It is not recommended within 200 feet of surface waters. If seeding is expected shortly after mulch, the decomposition of the chipped vegetation may tie up nutrients important to grass establishment.
Wood-based Mulch or Wood Straw	No visible water or dust during handling. Must be purchased from a supplier with a Solid Waste Handling Permit or one exempt from solid waste regulations.	2" thick min.; approx. 100 tons per acre (approx. 800 lbs. per cubic yard)	This material is often called "hog or hogged fuel". □ The use of mulch ultimately improves the organic matter in the soil. Special caution is advised regarding the source and composition of wood-based mulches. Its preparation typically does not provide any weed seed control, so evidence of residual vegetation in its composition or known inclusion of weed plants or seeds should be monitored and prevented (or minimized).
Wood Strand Mulch	A blend of loose, long, thin wood pieces derived from native conifer or deciduous trees with high length-to-width ratio.	2" thick min.	Cost-effective protection when applied with adequate thickness. A minimum of 95-percent of the wood strand shall have lengths between 2 and 10-inches, with a width and thickness between 1/16 and 3/8-inches. The mulch shall not contain resin, tannin, or other compounds in quantities that would be detrimental to plant life. Sawdust or wood shavings shall not be used as mulch. (WSDOT specification (9-14.4(4)))

BMP C122: Nets and Blankets

Purpose

Erosion control nets and blankets are intended to prevent erosion and hold seed and mulch in place on steep slopes and in channels so that vegetation can become well established. In addition, some nets and blankets can be used to permanently reinforce turf to protect drainage ways during high flows. Nets (commonly called matting) are strands of material woven into an open, but high-tensile strength net (for example, coconut fiber matting). Blankets are strands of material that are not tightly woven, but instead form a layer of interlocking fibers, typically held together by a biodegradable or photodegradable netting (for example, excelsior or straw blankets). They generally have lower tensile strength than nets, but cover the ground more completely. Coir (coconut fiber) fabric comes as both nets and blankets.

Conditions of Use

Erosion control nets and blankets should be used:

- To aid permanent vegetated stabilization of slopes 2H:1V or greater and with more than 10 feet of vertical relief.
- For drainage ditches and swales (highly recommended). The application of appropriate netting or blanket to drainage ditches and swales can protect bare soil from channelized runoff while vegetation is established. Nets and blankets also can capture a great deal of sediment due to their open, porous structure. Nets and blankets can be used to permanently stabilize channels and may provide a cost-effective, environmentally preferable alternative to riprap. 100 percent synthetic blankets manufactured for use in ditches may be easily reused as temporary ditch liners.

Disadvantages of blankets include:

- Surface preparation required.
- On slopes steeper than 2.5H:1V, blanket installers may need to be roped and harnessed for safety.
- They cost at least \$4,000-6,000 per acre installed.

Advantages of blankets include:

- Installation without mobilizing special equipment.
- Installation by anyone with minimal training
- Installation in stages or phases as the project progresses.

- Installers can hand place seed and fertilizer as they progress down the slope.
- Installation in any weather.
- There are numerous types of blankets that can be designed with various parameters in mind. Those parameters include: fiber blend, mesh strength, longevity, biodegradability, cost, and availability.

Design and Installation Specifications

- See [Figure II-4.1.3 Channel Installation](#) and [Figure II-4.1.4 Slope Installation](#) for typical orientation and installation of blankets used in channels and as slope protection. Note: these are typical only; all blankets must be installed per manufacturer's installation instructions.
- Installation is critical to the effectiveness of these products. If good ground contact is not achieved, runoff can concentrate under the product, resulting in significant erosion.
- Installation of Blankets on Slopes:
 1. Complete final grade and track walk up and down the slope.
 2. Install hydromulch with seed and fertilizer.
 3. Dig a small trench, approximately 12 inches wide by 6 inches deep along the top of the slope.
 4. Install the leading edge of the blanket into the small trench and staple approximately every 18 inches. NOTE: Staples are metal, "U"-shaped, and a minimum of 6 inches long. Longer staples are used in sandy soils. Biodegradable stakes are also available.
 5. Roll the blanket slowly down the slope as installer walks backwards. NOTE: The blanket rests against the installer's legs. Staples are installed as the blanket is unrolled. It is critical that the proper staple pattern is used for the blanket being installed. The blanket is not to be allowed to roll down the slope on its own as this stretches the blanket making it impossible to maintain soil contact. In addition, no one is allowed to walk on the blanket after it is in place.
 6. If the blanket is not long enough to cover the entire slope length, the trailing edge of the upper blanket should overlap the leading edge of the lower blanket and be stapled. On steeper slopes, this overlap should be installed in a small trench, stapled, and covered with soil.

- With the variety of products available, it is impossible to cover all the details of appropriate use and installation. Therefore, it is critical that the design engineer consult the manufacturer's information and that a site visit takes place in order to ensure that the product specified is appropriate. Information is also available at the following web sites:

1. WSDOT (Section 3.2.4):

<http://www.wsdot.wa.gov/NR/rdonlyres/3B41E087-FA86-4717-932D-D7A8556CCD57/0/ErosionTrainingManual.pdf>

2. Texas Transportation Institute:

http://www.txdot.gov/business/doing_business/product_evaluation/erosion_control.htm

- Use jute matting in conjunction with mulch ([BMP C121: Mulching](#)). Excelsior, woven straw blankets and coir (coconut fiber) blankets may be installed without mulch. There are many other types of erosion control nets and blankets on the market that may be appropriate in certain circumstances.
- In general, most nets (e.g., jute matting) require mulch in order to prevent erosion because they have a fairly open structure. Blankets typically do not require mulch because they usually provide complete protection of the surface.
- Extremely steep, unstable, wet, or rocky slopes are often appropriate candidates for use of synthetic blankets, as are riverbanks, beaches and other high-energy environments. If synthetic blankets are used, the soil should be hydromulched first.
- 100-percent biodegradable blankets are available for use in sensitive areas. These organic blankets are usually held together with a paper or fiber mesh and stitching which may last up to a year.
- Most netting used with blankets is photodegradable, meaning they break down under sunlight (not UV stabilized). However, this process can take months or years even under bright sun. Once vegetation is established, sunlight does not reach the mesh. It is not uncommon to find non-degraded netting still in place several years after installation. This can be a problem if maintenance requires the use of mowers or ditch cleaning equipment. In addition, birds and small animals can become trapped in the netting.

Maintenance Standards

- Maintain good contact with the ground. Erosion must not occur beneath the net or blanket.

- Repair and staple any areas of the net or blanket that are damaged or not in close contact with the ground.
- Fix and protect eroded areas if erosion occurs due to poorly controlled drainage.

Figure II-4.1.3 Channel Installation



[2014 Figure II-4.1.3 pdf download](#)

Figure II-4.1.4 Slope Installation



[2014 Figure II-4.1.4 pdf download](#)

Washington State Department of Ecology

[2012 Stormwater Management Manual for Western Washington, as Amended in December 2014. \(The 2014 SWMMWW\)](#)

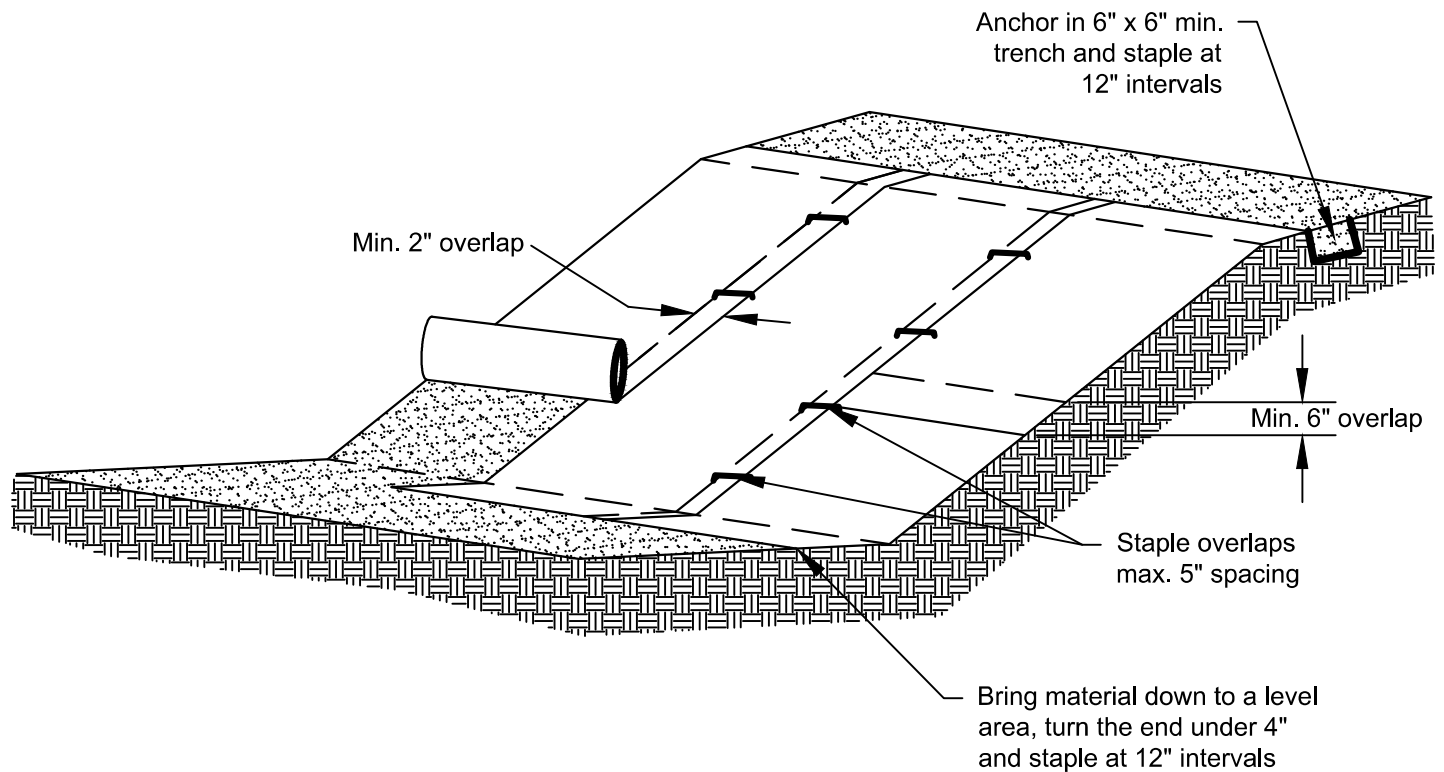

Notes:

1. Slope surface shall be smooth before placement for proper soil contact.
2. Stapling pattern as per manufacturer's recommendations.
3. Do not stretch blankets/mattings tight - allow the rolls to mold to any irregularities.
4. For slopes less than 3H:1V, rolls may be placed in horizontal strips.
5. If there is a berm at the top of the slope, anchor upslope of the berm.
6. Lime, fertilize, and seed before installation. Planting of shrubs, trees, etc. should occur after installation.

NOT TO SCALE

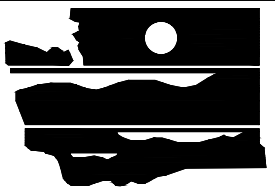

DEPARTMENT OF
ECOLOGY
State of Washington

Figure II-4.1.4 Slope Installation

Revised June 2015

Please see <http://www.ecy.wa.gov/copyright.html> for copyright notice including permissions, limitation of liability, and disclaimer.

BMP C123: Plastic Covering

Purpose Plastic covering provides immediate, short-term erosion protection to slopes and disturbed areas.

- Conditions of Use*
- Plastic covering may be used on disturbed areas that require cover measures for less than 30 days, except as stated below.
 - Plastic is particularly useful for protecting cut and fill slopes and stockpiles. Note: The relatively rapid breakdown of most polyethylene sheeting makes it unsuitable for long-term (greater than six months) applications.
 - Clear plastic sheeting can be used over newly-seeded areas to create a greenhouse effect and encourage grass growth if the hydroseed was installed too late in the season to establish 75 percent grass cover, or if the wet season started earlier than normal. Clear plastic should not be used for this purpose during the summer months because the resulting high temperatures can kill the grass.
 - Due to rapid runoff caused by plastic sheeting, this method shall not be used upslope of areas that might be adversely impacted by concentrated runoff. Such areas include steep and/or unstable slopes.
 - While plastic is inexpensive to purchase, the added cost of installation, maintenance, removal, and disposal make this an expensive material, up to \$1.50-2.00 per square yard.
 - Whenever plastic is used to protect slopes, water collection measures must be installed at the base of the slope. These measures include plastic-covered berms, channels, and pipes used to convey clean rainwater away from bare soil and disturbed areas. At no time is clean runoff from a plastic covered slope to be mixed with dirty runoff from a project.
 - Other uses for plastic include:
 1. Temporary ditch liner;
 2. Pond liner in temporary sediment pond;
 3. Liner for bermed temporary fuel storage area if plastic is not reactive to the type of fuel being stored;
 4. Emergency slope protection during heavy rains; and,
 5. Temporary drainpipe (“elephant trunk”) used to direct water.

***Design and
Installation
Specifications***

- Plastic slope cover must be installed as follows:
 1. Run plastic up and down slope, not across slope;
 2. Plastic may be installed perpendicular to a slope if the slope length is less than 10 feet;
 3. Minimum of 8-inch overlap at seams;
 4. On long or wide slopes, or slopes subject to wind, all seams should be taped;
 5. Place plastic into a small (12-inch wide by 6-inch deep) slot trench at the top of the slope and backfill with soil to keep water from flowing underneath;
 6. Place sand filled burlap or geotextile bags every 3 to 6 feet along seams and pound a wooden stake through each to hold them in place;
 7. Inspect plastic for rips, tears, and open seams regularly and repair immediately. This prevents high velocity runoff from contacting bare soil which causes extreme erosion;
 8. Sandbags may be lowered into place tied to ropes. However, all sandbags must be staked in place.
- Plastic sheeting shall have a minimum thickness of 0.06 millimeters.
- If erosion at the toe of a slope is likely, a gravel berm, riprap, or other suitable protection shall be installed at the toe of the slope in order to reduce the velocity of runoff.

***Maintenance
Standards***

- Torn sheets must be replaced and open seams repaired.
- If the plastic begins to deteriorate due to ultraviolet radiation, it must be completely removed and replaced.
- When the plastic is no longer needed, it shall be completely removed.
- Dispose of old tires appropriately.

BMP C125: Topsoiling / Composting

Purpose

Topsoiling and composting provide a suitable growth medium for final site stabilization with vegetation. While not a permanent cover practice in itself, topsoiling and composting are an integral component of providing permanent cover in those areas where there is an unsuitable soil surface for plant growth. Use this BMP in conjunction with other BMPs such as seeding, mulching, or sodding. Note that this BMP is functionally the same as [BMP T5.13: Post-Construction Soil Quality and Depth](#) which is required for all disturbed areas that will be developed as lawn or landscaped areas at the completed project site.

Native soils and disturbed soils that have been organically amended not only retain much more stormwater, but they also serve as effective biofilters for urban pollutants and, by supporting more vigorous plant growth, reduce the water, fertilizer and pesticides needed to support installed landscapes. Topsoil does not include any subsoils but only the material from the top several inches including organic debris.

Conditions of Use

- Permanent landscaped areas shall contain healthy topsoil that reduces the need for fertilizers, improves overall topsoil quality, provides for better vegetal health and vitality, improves hydrologic characteristics, and reduces the need for irrigation.
- Leave native soils and the duff layer undisturbed to the maximum extent practicable. Stripping of existing, properly functioning soil system and vegetation for the purpose of topsoiling during construction is not acceptable. Preserve existing soil systems in undisturbed and uncompacted conditions if functioning properly.
- Areas that already have good topsoil, such as undisturbed areas, do not require soil amendments.
- Restore, to the maximum extent practical, native soils disturbed during clearing and grading to a condition equal to or better than the original site condition's moisture-holding capacity. Use on-site native topsoil, incorporate amendments into on-site soil, or import blended topsoil to meet this requirement.
- Topsoiling is a required procedure when establishing vegetation on shallow soils, and soils of critically low pH (high acid) levels.
- Beware of where the topsoil comes from, and what vegetation was on site before disturbance, invasive plant seeds may be included and could cause problems for establishing native plants, landscaped areas, or grasses.

- Topsoil from the site will contain mycorrhizal bacteria that are necessary for healthy root growth and nutrient transfer. These native mycorrhiza are acclimated to the site and will provide optimum conditions for establishing grasses. Use commercially available mycorrhiza products when using off-site topsoil.

Design and Installation Specifications

Meet the following requirements for disturbed areas that will be developed as lawn or landscaped areas at the completed project site:

- Maximize the depth of the topsoil wherever possible to provide the maximum possible infiltration capacity and beneficial growth medium. Topsoil shall have:
 - A minimum depth of 8-inches. Scarify subsoils below the topsoil layer at least 4-inches with some incorporation of the upper material to avoid stratified layers, where feasible. Ripping or re-structuring the subgrade may also provide additional benefits regarding the overall infiltration and interflow dynamics of the soil system.
 - A minimum organic content of 10% dry weight in planting beds, and 5% organic matter content in turf areas. Incorporate organic amendments to a minimum 8-inch depth except where tree roots or other natural features limit the depth of incorporation.
 - A pH between 6.0 and 8.0 or matching the pH of the undisturbed soil.
 - If blended topsoil is imported, then fines should be limited to 25 percent passing through a 200 sieve.
 - Mulch planting beds with 2 inches of organic material
- Accomplish the required organic content, depth, and pH by returning native topsoil to the site, importing topsoil of sufficient organic content, and/or incorporating organic amendments. When using the option of incorporating amendments to meet the organic content requirement, use compost that meets the compost specification for Bioretention (See [BMP T7.30: Bioretention Cells, Swales, and Planter Boxes](#)), with the exception that the compost may have up to 35% biosolids or manure.
- Sections three through seven of the document entitled, *Guidelines and Resources for Implementing Soil Quality and Depth BMP T5.13 in WDOE Stormwater Management Manual for Western Washington*, provides useful guidance for implementing whichever option is chosen. It includes guidance for pre-approved default strategies and guidance for custom strategies. Check with your local jurisdiction concerning its acceptance of this guidance. It is available through the

organization, Soils for Salmon. As of this printing the document may be found at:

http://www.soilsforsalmon.org/pdf/Soil_BMP_Manual.pdf.

- The final composition and construction of the soil system will result in a natural selection or favoring of certain plant species over time. For example, incorporation of topsoil may favor grasses, while layering with mildly acidic, high-carbon amendments may favor more woody vegetation.
- Allow sufficient time in scheduling for topsoil spreading prior to seeding, sodding, or planting.
- Take care when applying top soil to subsoils with contrasting textures. Sandy topsoil over clayey subsoil is a particularly poor combination, as water creeps along the junction between the soil layers and causes the topsoil to slough. If topsoil and subsoil are not properly bonded, water will not infiltrate the soil profile evenly and it will be difficult to establish vegetation. The best method to prevent a lack of bonding is to actually work the topsoil into the layer below for a depth of at least 6 inches.
- Field exploration of the site shall be made to determine if there is surface soil of sufficient quantity and quality to justify stripping. Topsoil shall be friable and loamy (loam, sandy loam, silt loam, sandy clay loam, and clay loam). Avoid areas of natural ground water recharge.
- Stripping shall be confined to the immediate construction area. A 4-inch to 6-inch stripping depth is common, but depth may vary depending on the particular soil. All surface runoff control structures shall be in place prior to stripping.
- Do not place topsoil while in a frozen or muddy condition, when the subgrade is excessively wet, or when conditions exist that may otherwise be detrimental to proper grading or proposed sodding or seeding.
- In any areas requiring grading remove and stockpile the duff layer and topsoil on site in a designated, controlled area, not adjacent to public resources and critical areas. Stockpiled topsoil is to be reapplied to other portions of the site where feasible.
- Locate the topsoil stockpile so that it meets specifications and does not interfere with work on the site. It may be possible to locate more than one pile in proximity to areas where topsoil will be used.

Stockpiling of topsoil shall occur in the following manner:

- Side slopes of the stockpile shall not exceed 2H:1V.
- Between October 1 and April 30:

- An interceptor dike with gravel outlet and silt fence shall surround all topsoil.
- Within 2 days complete erosion control seeding, or covering stockpiles with clear plastic, or other mulching materials.
- Between May 1 and September 30:
 - An interceptor dike with gravel outlet and silt fence shall surround all topsoil if the stockpile will remain in place for a longer period of time than active construction grading.
 - Within 7 days complete erosion control seeding, or covering stockpiles with clear plastic, or other mulching materials.
- When native topsoil is to be stockpiled and reused the following should apply to ensure that the mycorrhizal bacterial, earthworms, and other beneficial organisms will not be destroyed:
 1. Re-install topsoil within 4 to 6 weeks.
 2. Do not allow the saturation of topsoil with water.
 3. Do not use plastic covering.

Maintenance Standards

- Inspect stockpiles regularly, especially after large storm events. Stabilize any areas that have eroded.
- Establish soil quality and depth toward the end of construction and once established, protect from compaction, such as from large machinery use, and from erosion.
- Plant and mulch soil after installation.
- Leave plant debris or its equivalent on the soil surface to replenish organic matter.
- Reduce and adjust, where possible, the use of irrigation, fertilizers, herbicides and pesticides, rather than continuing to implement formerly established practices.

BMP C130: Surface Roughening

Purpose

Surface roughening aids in the establishment of vegetative cover, reduces runoff velocity, increases infiltration, and provides for sediment trapping through the provision of a rough soil surface. Horizontal depressions are created by operating a tiller or other suitable equipment on the contour or by leaving slopes in a roughened condition by not fine grading them.

Use this BMP in conjunction with other BMPs such as seeding, mulching, or sodding.

Conditions for Use

- All slopes steeper than 3H:1V and greater than 5 vertical feet require surface roughening to a depth of 2 to 4 inches prior to seeding..
- Areas that will not be stabilized immediately may be roughened to reduce runoff velocity until seeding takes place.
- Slopes with a stable rock face do not require roughening.
- Slopes where mowing is planned should not be excessively roughened.

Design and Installation Specifications

There are different methods for achieving a roughened soil surface on a slope, and the selection of an appropriate method depends upon the type of slope. Roughening methods include stair-step grading, grooving, contour furrows, and tracking. See [Figure II-4.1.5 Surface Roughening by Tracking and Contour Furrows](#) for tracking and contour furrows. Factors to be considered in choosing a method are slope steepness, mowing requirements, and whether the slope is formed by cutting or filling.

- Disturbed areas that will not require mowing may be stair-step graded, grooved, or left rough after filling.
- Stair-step grading is particularly appropriate in soils containing large amounts of soft rock. Each "step" catches material that sloughs from above, and provides a level site where vegetation can become established. Stairs should be wide enough to work with standard earth moving equipment. Stair steps must be on contour or gullies will form on the slope.
- Areas that will be mowed (these areas should have slopes less steep than 3H:1V) may have small furrows left by disking, harrowing, raking, or seed-planting machinery operated on the contour.

- Graded areas with slopes steeper than 3H:1V but less than 2H:1V should be roughened before seeding. This can be accomplished in a variety of ways, including "track walking," or driving a crawler tractor up and down the slope, leaving a pattern of cleat imprints parallel to slope contours.
- Tracking is done by operating equipment up and down the slope to leave horizontal depressions in the soil.

Maintenance Standards

- Areas that are graded in this manner should be seeded as quickly as possible.
- Regular inspections should be made of the area. If rills appear, they should be re-graded and re-seeded immediately.

Figure II-4.1.5 Surface Roughening by Tracking and Contour Furrows



[2014 Figure II-4.1.5 pdf download](#)

Washington State Department of Ecology

[2012 Stormwater Management Manual for Western Washington, as Amended in December 2014 \(The 2014 SWMMWW\)](#)

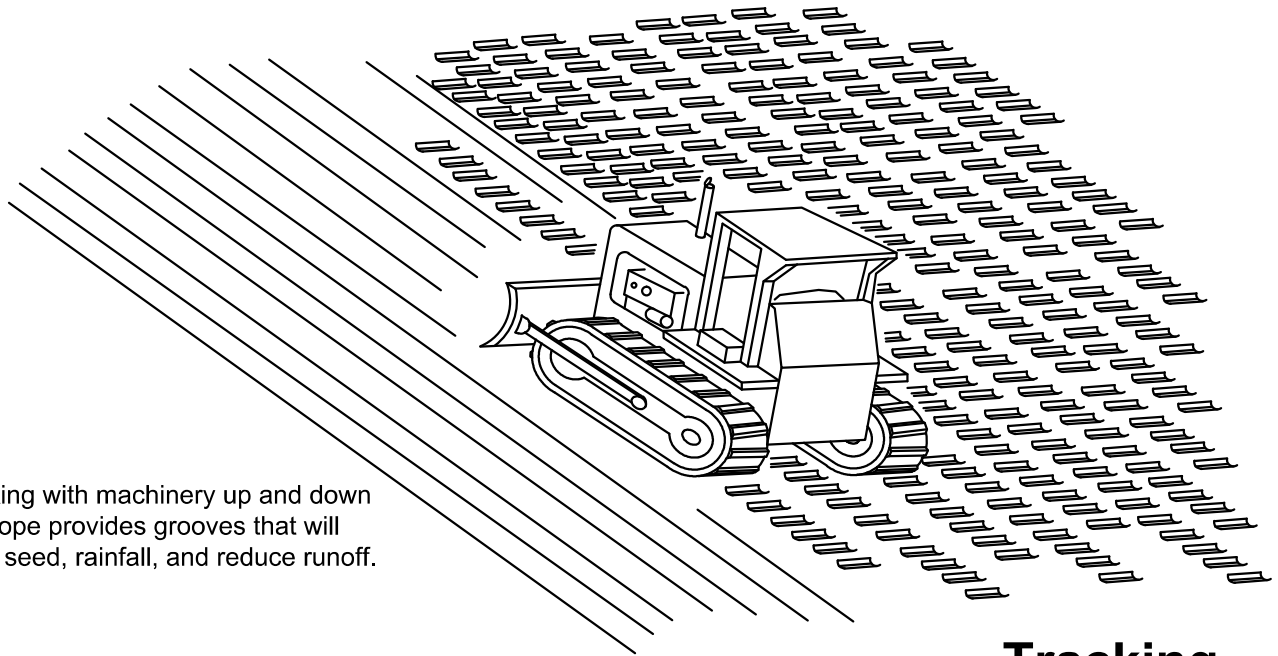

Tracking with machinery up and down the slope provides grooves that will catch seed, rainfall, and reduce runoff.

Tracking

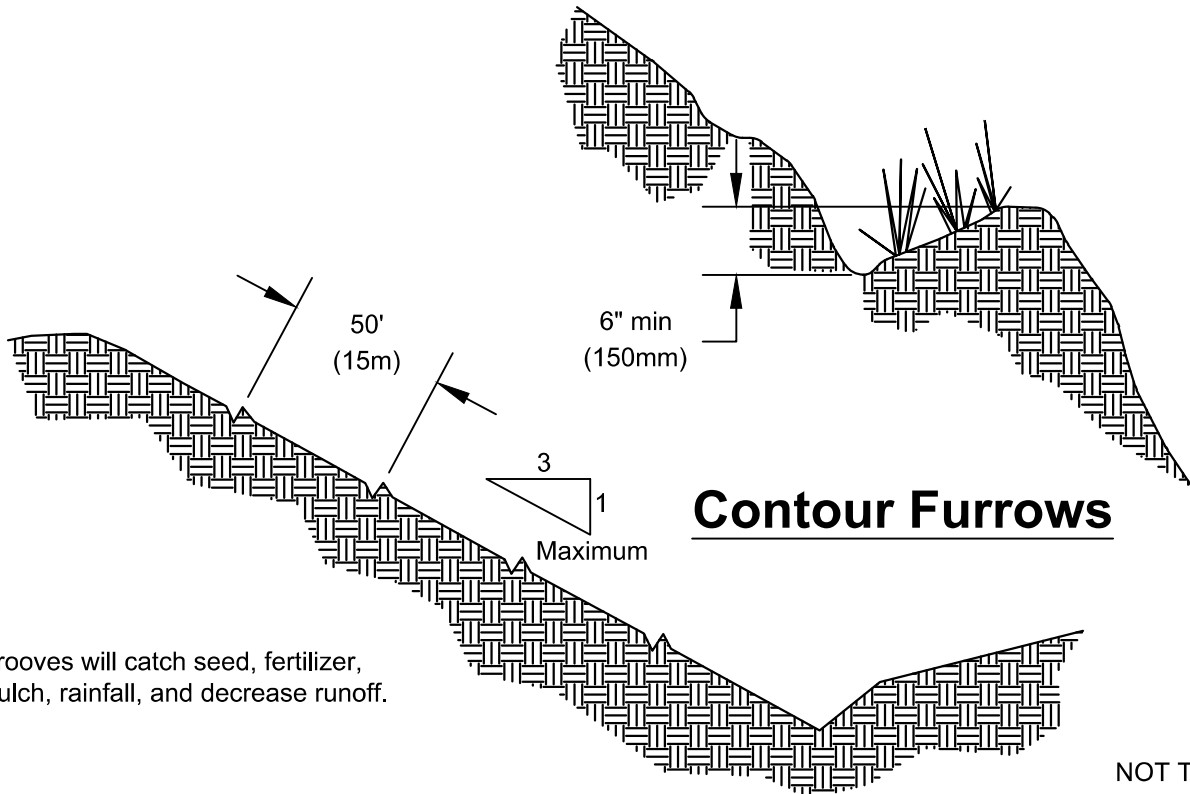

Grooves will catch seed, fertilizer, mulch, rainfall, and decrease runoff.

Contour Furrows

NOT TO SCALE



DEPARTMENT OF
ECOLOGY
State of Washington

Figure II-4.1.5 Surface Roughening by Tracking and Contour Furrows

Revised June 2015

Please see <http://www.ecy.wa.gov/copyright.html> for copyright notice including permissions, limitation of liability, and disclaimer.

BMP C131: Gradient Terraces

Purpose

Gradient terraces reduce erosion damage by intercepting surface runoff and conducting it to a stable outlet at a non-erosive velocity.

Conditions of Use

- Gradient terraces normally are limited to denuded land having a water erosion problem. They should not be constructed on deep sands or on soils that are too stony, steep, or shallow to permit practical and economical installation and maintenance. Gradient terraces may be used only where suitable outlets are or will be made available. See [Figure II-4.1.6 Gradient Terraces](#) for gradient terraces.

Design and Installation Specifications

- The maximum vertical spacing of gradient terraces should be determined by the following method:

$$VI = (0.8)s + y$$

Where:

VI = vertical interval in feet

s = land rise per 100 feet, expressed in feet

y = a soil and cover variable with values from 1.0 to 4.0

Values of “y” are influenced by soil erodibility and cover practices. The lower values are applicable to erosive soils where little to no residue is left on the surface. The higher value is applicable only to erosion-resistant soils where a large amount of residue (1½ tons of straw/acre equivalent) is on the surface.

- The minimum constructed cross-section should meet the design dimensions.
- The top of the constructed ridge should not be lower at any point than the design elevation plus the specified overfill for settlement. The opening at the outlet end of the terrace should have a cross section equal to that specified for the terrace channel.
- Channel grades may be either uniform or variable with a maximum grade of 0.6 feet per 100 feet length (0.6%). For short distances, terrace grades may be increased to improve alignment. The

channel velocity should not exceed that which is nonerosive for the soil type.

- All gradient terraces should have adequate outlets. Such an outlet may be a grassed waterway, vegetated area, or tile outlet. In all cases the outlet must convey runoff from the terrace or terrace system to a point where the outflow will not cause damage. Vegetative cover should be used in the outlet channel.
- The design elevation of the water surface of the terrace should not be lower than the design elevation of the water surface in the outlet at their junction, when both are operating at design flow.
- Vertical spacing determined by the above methods may be increased as much as 0.5 feet or 10 percent, whichever is greater, to provide better alignment or location, to avoid obstacles, to adjust for equipment size, or to reach a satisfactory outlet. The drainage area above the terrace should not exceed the area that would be drained by a terrace with normal spacing.
- The terrace should have enough capacity to handle the peak runoff expected from a 2-year, 24-hour design storm without overtopping.
- The terrace cross-section should be proportioned to fit the land slope. The ridge height should include a reasonable settlement factor. The ridge should have a minimum top width of 3 feet at the design height. The minimum cross-sectional area of the terrace channel should be 8 square feet for land slopes of 5 percent or less, 7 square feet for slopes from 5 to 8 percent, and 6 square feet for slopes steeper than 8 percent. The terrace can be constructed wide enough to be maintained using a small vehicle.

Maintenance Standards

- Maintenance should be performed as needed. Terraces should be inspected regularly; at least once a year, and after large storm events.

Figure II-4.1.6 Gradient Terraces



[2014 Figure II-4.1.6 pdf download](#)

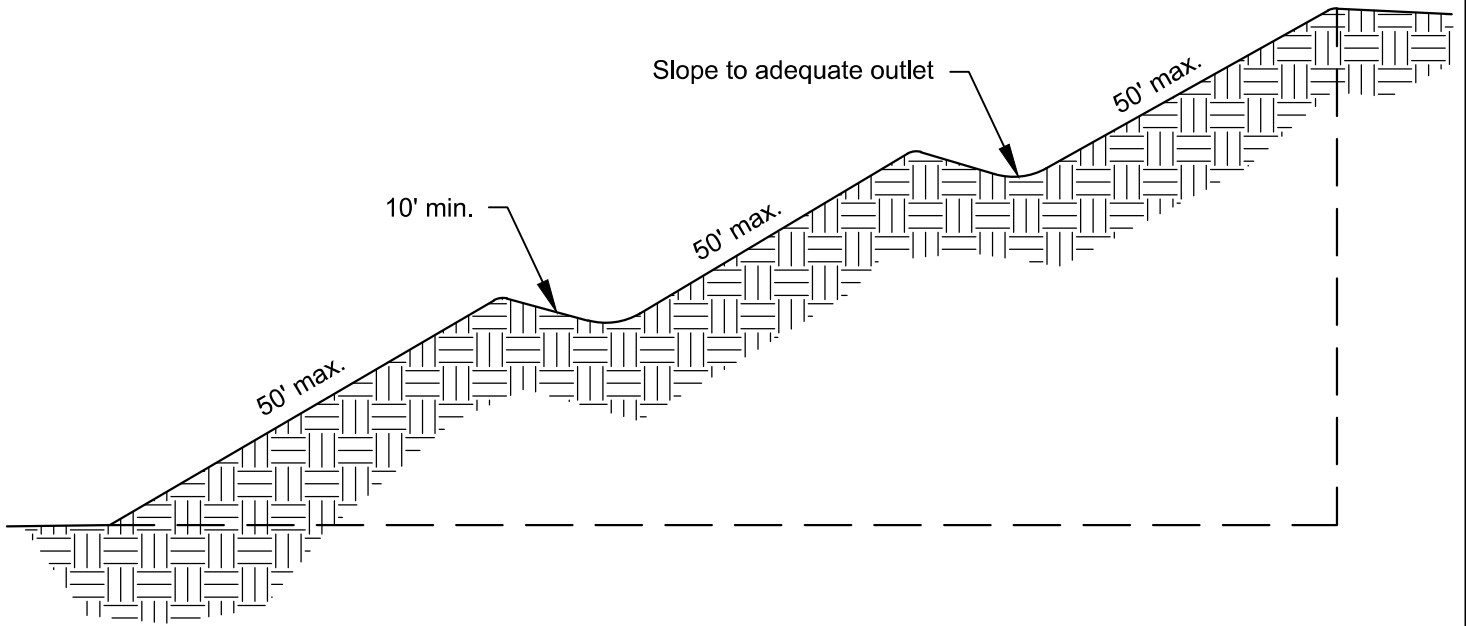

NOT TO SCALE



Figure II-4.1.6
Gradient Terraces

Revised June 2015

Please see <http://www.ecy.wa.gov/copyright.html> for copyright notice including permissions, limitation of liability, and disclaimer.

BMP C140: Dust Control

Purpose

Dust control prevents wind transport of dust from disturbed soil surfaces onto roadways, drainage ways, and surface waters.

Conditions of Use

- In areas (including roadways) subject to surface and air movement of dust where on-site and off-site impacts to roadways, drainage ways, or surface waters are likely.

Design and Installation Specifications

- Vegetate or mulch areas that will not receive vehicle traffic. In areas where planting, mulching, or paving is impractical, apply gravel or landscaping rock.
- Limit dust generation by clearing only those areas where immediate activity will take place, leaving the remaining area(s) in the original condition, if stable. Maintain the original ground cover as long as practical.
- Construct natural or artificial windbreaks or windscreens. These may be designed as enclosures for small dust sources.
- Sprinkle the site with water until surface is wet. Repeat as needed. To prevent carryout of mud onto street, refer to Stabilized Construction Entrance (BMP C105).
- Irrigation water can be used for dust control. Irrigation systems should be installed as a first step on sites where dust control is a concern.
- Spray exposed soil areas with a dust palliative, following the manufacturer's instructions and cautions regarding handling and application. Used oil is prohibited from use as a dust suppressant. Local governments may approve other dust palliatives such as calcium chloride or PAM.
- PAM (BMP C126) added to water at a rate of 0.5 lbs. per 1,000 gallons of water per acre and applied from a water truck is more effective than water alone. This is due to the increased infiltration of water into the soil and reduced evaporation. In addition, small soil particles are bonded together and are not as easily transported by wind. Adding PAM may actually reduce the quantity of water needed for dust control, especially in eastern Washington. Since the wholesale cost of PAM is about \$ 4.00 per pound, this is an extremely cost-effective dust control method.

Techniques that can be used for unpaved roads and lots include:

- Lower speed limits. High vehicle speed increases the amount of dust stirred up from unpaved roads and lots.
- Upgrade the road surface strength by improving particle size, shape, and mineral types that make up the surface and base materials.

- Add surface gravel to reduce the source of dust emission. Limit the amount of fine particles (those smaller than .075 mm) to 10 to 20 percent.
- Use geotextile fabrics to increase the strength of new roads or roads undergoing reconstruction.
- Encourage the use of alternate, paved routes, if available.
- Restrict use by tracked vehicles and heavy trucks to prevent damage to road surface and base.
- Apply chemical dust suppressants using the admix method, blending the product with the top few inches of surface material. Suppressants may also be applied as surface treatments.
- Pave unpaved permanent roads and other trafficked areas.
- Use vacuum street sweepers.
- Remove mud and other dirt promptly so it does not dry and then turn into dust.
- Limit dust-causing work on windy days.
- Contact your local Air Pollution Control Authority for guidance and training on other dust control measures. Compliance with the local Air Pollution Control Authority constitutes compliance with this BMP.

Maintenance Standards

Respray area as necessary to keep dust to a minimum.

BMP C154: Concrete Washout Area

Purpose

Prevent or reduce the discharge of pollutants from concrete waste to stormwater by conducting washout off-site, or performing on-site washout in a designated area.

Conditions of Use

Concrete washout areas are implemented on construction projects where:

- Concrete is used as a construction material
- It is not possible to dispose of all concrete wastewater and washout off-site (ready mix plant, etc.).
- Concrete truck drums are washed on-site.

Note that auxiliary concrete truck components (e.g. chutes and hoses) and small concrete handling equipment (e.g. hand tools, screeds, shovels, rakes, floats, trowels, and wheelbarrows) may be washed into formed areas awaiting concrete pour.

At no time shall concrete be washed off into the footprint of an area where an infiltration feature will be installed.

Design and Installation Specifications

Implementation

- Perform washout of concrete truck drums at an approved off-site location or in designated concrete washout areas only.
- Do not wash out concrete onto non-formed areas, or into storm drains, open ditches, streets, or streams.
- Wash equipment difficult to move, such as concrete paving machines, in areas that do not directly drain to natural or constructed stormwater conveyance or potential infiltration areas.
- Do not allow excess concrete to be dumped on-site, except in designated concrete washout areas as allowed above.
- Concrete washout areas may be prefabricated concrete washout containers, or self-installed structures (above-grade or below-grade).
- Prefabricated containers are most resistant to damage and protect against spills and leaks. Companies may offer delivery service and provide regular maintenance and disposal of solid and liquid waste.

- If self-installed concrete washout areas are used, below-grade structures are preferred over above-grade structures because they are less prone to spills and leaks.
- Self-installed above-grade structures should only be used if excavation is not practical.
- Concrete washout areas shall be constructed and maintained in sufficient quantity and size to contain all liquid and concrete waste generated by washout operations.

Education

- Discuss the concrete management techniques described in this BMP with the ready-mix concrete supplier before any deliveries are made.
- Educate employees and subcontractors on the concrete waste management techniques described in this BMP.
- Arrange for the contractor's superintendent or Certified Erosion and Sediment Control Lead (CESCL) to oversee and enforce concrete waste management procedures.
- A sign should be installed adjacent to each concrete washout area to inform concrete equipment operators to utilize the proper facilities.

Contracts

Incorporate requirements for concrete waste management into concrete supplier and subcontractor agreements.

Location and Placement

- Locate concrete washout areas at least 50 feet from sensitive areas such as storm drains, open ditches, water bodies, or wetlands.
- Allow convenient access to the concrete washout area for concrete trucks, preferably near the area where the concrete is being poured.
- If trucks need to leave a paved area to access the concrete washout area, prevent track-out with a pad of rock or quarry spalls (see [BMP C105: Stabilized Construction Access](#)). These areas should be far enough away from other construction traffic to reduce the likelihood of accidental damage and spills.
- The number of concrete washout areas you install should depend on the expected demand for storage capacity.
- On large sites with extensive concrete work, concrete washout areas should be placed in multiple locations for ease of use by concrete truck drivers.

Concrete Truck Washout Procedures

- Washout of concrete truck drums shall be performed in designated concrete washout areas only.

- Concrete washout from concrete pumper bins can be washed into concrete pumper trucks and discharged into designated concrete washout areas or properly disposed of off-site.

Concrete Washout Area Installation

- Concrete washout areas should be constructed as shown in the figures below, with a recommended minimum length and minimum width of 10 ft, but with sufficient quantity and volume to contain all liquid and concrete waste generated by washout operations.
- Plastic lining material should be a minimum of 10 mil polyethylene sheeting and should be free of holes, tears, or other defects that compromise the impermeability of the material.
- Lath and flagging should be commercial type.
- Liner seams shall be installed in accordance with manufacturers' recommendations.
- Soil base shall be prepared free of rocks or other debris that may cause tears or holes in the plastic lining material.

Maintenance Standards

Inspection and Maintenance

- Inspect and verify that concrete washout areas are in place prior to the commencement of concrete work.
- Once concrete wastes are washed into the designated washout area and allowed to harden, the concrete should be broken up, removed, and disposed of per applicable solid waste regulations. Dispose of hardened concrete on a regular basis.
- During periods of concrete work, inspect the concrete washout areas daily to verify continued performance.
 - Check overall condition and performance.
 - Check remaining capacity (% full).
 - If using self-installed concrete washout areas, verify plastic liners are intact and sidewalls are not damaged.
 - If using prefabricated containers, check for leaks.
- Maintain the concrete washout areas to provide adequate holding capacity with a minimum freeboard of 12 inches.
- Concrete washout areas must be cleaned, or new concrete washout areas must be constructed and ready for use once the concrete washout area is 75% full.
- If the concrete washout area is nearing capacity, vacuum and dispose of the waste material in an approved manner.

- Do not discharge liquid or slurry to waterways, storm drains or directly onto ground.
 - Do not discharge to the sanitary sewer without local approval.
 - Place a secure, non-collapsing, non-water collecting cover over the concrete washout area prior to predicted wet weather to prevent accumulation and overflow of precipitation.
 - Remove and dispose of hardened concrete and return the structure to a functional condition. Concrete may be reused on-site or hauled away for disposal or recycling.
- When you remove materials from a self-installed concrete washout area, build a new structure; or, if the previous structure is still intact, inspect for signs of weakening or damage, and make any necessary repairs. Re-line the structure with new plastic after each cleaning.

Removal of Concrete Washout Areas

- When concrete washout areas are no longer required for the work, the hardened concrete, slurries and liquids shall be removed and properly disposed of.
- Materials used to construct concrete washout areas shall be removed from the site of the work and disposed of or recycled.
- Holes, depressions or other ground disturbance caused by the removal of the concrete washout areas shall be backfilled, repaired, and stabilized to prevent erosion.

Figure II-3.7: Concrete Washout Area with Wood Planks

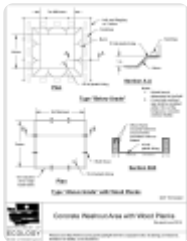

[pdf download](#)

Figure II-3.8: Concrete Washout Area with Straw Bales

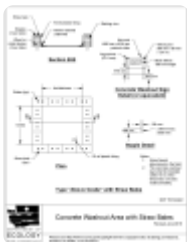

[pdf download](#)

Figure II-3.9: Prefabricated Concrete Washout Container w/Ramp



[pdf download](#)

Washington State Department of Ecology

2019 Stormwater Management Manual for Western Washington (2019 SWMMWW)

Publication No.19-10-021

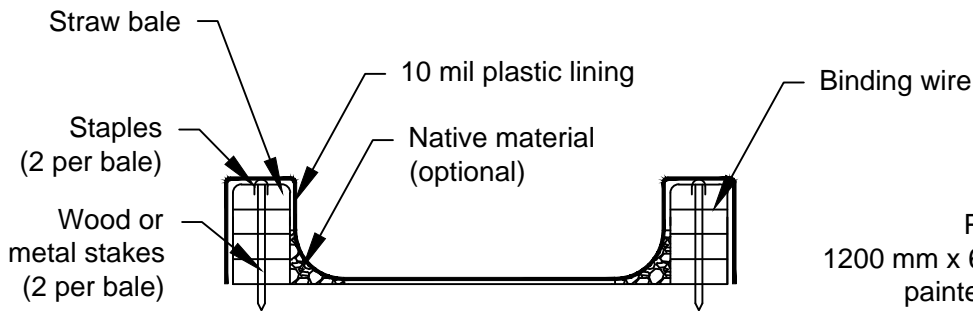

Section B-B

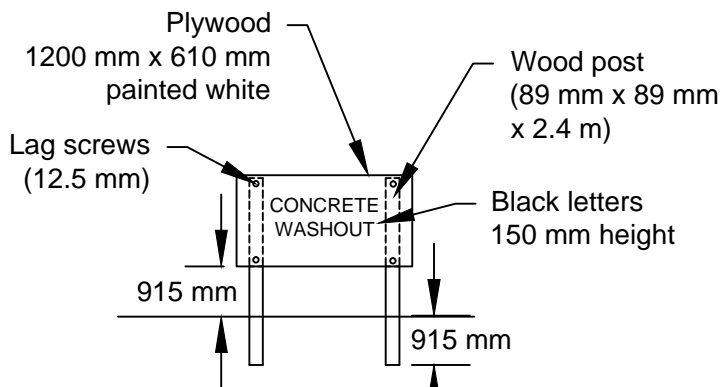

Concrete Washout Sign Detail (or equivalent)

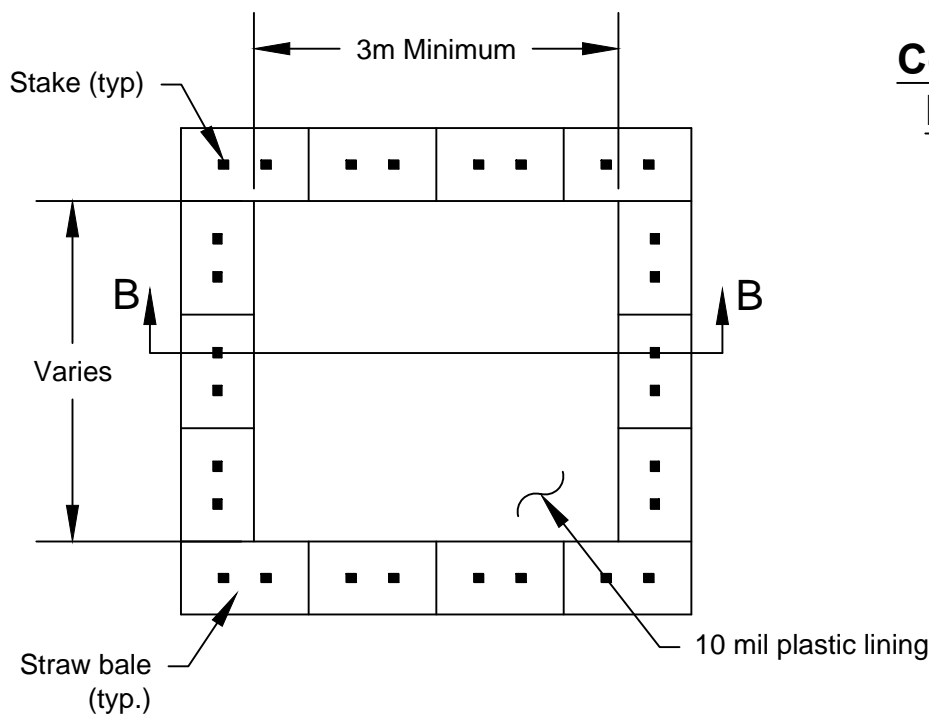

Plan

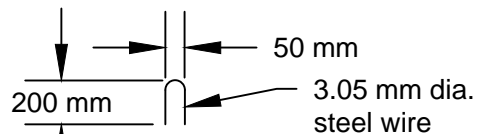

Staple Detail

Notes:

1. Actual layout determined in the field.
2. The concrete washout sign shall be installed within 10 m of the temporary concrete washout facility.

Type "Above Grade" with Straw Bales

NOT TO SCALE



DEPARTMENT OF
ECOLOGY
State of Washington

Concrete Washout Area with Straw Bales

Revised June 2016

Please see <http://www.ecy.wa.gov/copyright.html> for copyright notice including permissions, limitation of liability, and disclaimer.

BMP C160: Certified Erosion and Sediment Control Lead

Purpose

The project proponent designates at least one person as the responsible representative in charge of erosion and sediment control (ESC), and water quality protection. The designated person shall be responsible for ensuring compliance with all local, state, and federal erosion and sediment control and water quality requirements. Construction sites one acre or larger that discharge to waters of the State must designate a Certified Erosion and Sediment Control Lead (CESCL) as the responsible representative.

Conditions of Use

A CESCL shall be made available on projects one acre or larger that discharge stormwater to surface waters of the state. Sites less than one acre may have a person without CESCL certification conduct inspections.

The CESCL shall:

- Have a current certificate proving attendance in an erosion and sediment control training course that meets the minimum ESC training and certification requirements established by Ecology.

Ecology has provided the minimum requirements for CESCL course training, as well as a list of ESC training and certification providers at:

<https://ecology.wa.gov/Regulations-Permits/Permits-certifications/Certified-erosion-sediment-control>

OR

- Be a Certified Professional in Erosion and Sediment Control (CPESC). For additional information go to:

<http://www.envirocertintl.org/cpesc/>

Specifications

- CESCL certification shall remain valid for three years.
- The CESCL shall have authority to act on behalf of the contractor or project proponent and shall be available, or on-call, 24 hours per day throughout the period of construction.
- The Construction SWPPP shall include the name, telephone number, fax number, and address of the designated CESCL. See [II-2 Construction Stormwater Pollution Prevention Plans \(Construction SWPPPs\)](#).
- A CESCL may provide inspection and compliance services for multiple construction projects in the same geographic region, but must be on site whenever earthwork activities are occurring that could generate

release of turbid water.

- Duties and responsibilities of the CESCL shall include, but are not limited to the following:
 - Maintaining a permit file on site at all times which includes the Construction SWPPP and any associated permits and plans.
 - Directing BMP installation, inspection, maintenance, modification, and removal.
 - Updating all project drawings and the Construction SWPPP with changes made.
 - Completing any sampling requirements including reporting results using electronic Discharge Monitoring Reports (WebDMR).
 - Facilitate, participate in, and take corrective actions resulting from inspections performed by outside agencies or the owner.
 - Keeping daily logs, and inspection reports. Inspection reports should include:
 - Inspection date/time.
 - Weather information; general conditions during inspection and approximate amount of precipitation since the last inspection.
 - Visual monitoring results, including a description of discharged stormwater. The presence of suspended sediment, turbid water, discoloration, and oil sheen shall be noted, as applicable.
 - Any water quality monitoring performed during inspection.
 - General comments and notes, including a brief description of any BMP repairs, maintenance or installations made as a result of the inspection.
 - A summary or list of all BMPs implemented, including observations of all erosion/sediment control structures or practices. The following shall be noted:
 1. Locations of BMPs inspected.
 2. Locations of BMPs that need maintenance.
 3. Locations of BMPs that failed to operate as designed or intended.
 4. Locations of where additional or different BMPs are required.

Washington State Department of Ecology

2019 Stormwater Management Manual for Western Washington (2019 SWMMWW)

Publication No.19-10-021

BMP C200: Interceptor Dike and Swale

Purpose

Provide a ridge of compacted soil, or a ridge with an upslope swale, at the top or base of a disturbed slope or along the perimeter of a disturbed construction area to convey stormwater. Use the dike and/or swale to intercept the runoff from unprotected areas and direct it to areas where erosion can be controlled. This can prevent storm runoff from entering the work area or sediment-laden runoff from leaving the construction site.

Conditions of Use

Where the runoff from an exposed site or disturbed slope must be conveyed to an erosion control facility which can safely convey the stormwater.

- Locate upslope of a construction site to prevent runoff from entering disturbed area.
- When placed horizontally across a disturbed slope, it reduces the amount and velocity of runoff flowing down the slope.
- Locate downslope to collect runoff from a disturbed area and direct water to a sediment basin.

Design and Installation Specifications

- Dike and/or swale and channel must be stabilized with temporary or permanent vegetation or other channel protection during construction.
- Channel requires a positive grade for drainage; steeper grades require channel protection and check dams.
- Review construction for areas where overtopping may occur.
- Can be used at top of new fill before vegetation is established.
- May be used as a permanent diversion channel to carry the runoff.
- Sub-basin tributary area should be one acre or less.
- Design capacity for the peak volumetric flow rate calculated using a 10-minute time step from a 10-year, 24-hour storm, assuming a Type 1A rainfall distribution, for temporary facilities. Alternatively, use 1.6 times the 10-year, 1-hour flow indicated by an approved continuous runoff model. For

facilities that will also serve on a permanent basis, consult the local government's drainage requirements.

Interceptor dikes shall meet the following criteria:

- Top Width: 2 feet minimum.
- Height: 1.5 feet minimum on berm.
- Side Slope: 2H:1V or flatter.
- Grade: Depends on topography, however, dike system minimum is 0.5%, and maximum is 1%.
- Compaction: Minimum of 90 percent ASTM D698 standard proctor.
- Horizontal Spacing of Interceptor Dikes:

Average Slope	Slope Percent	Flowpath Length
20H:1V or less	3-5%	300 feet
(10 to 20)H:1V	5-10%	200 feet
(4 to 10)H:1V	10-25%	100 feet
(2 to 4)H:1V	25-50%	50 feet

- Stabilization: depends on velocity and reach
- Slopes <5%: Seed and mulch applied within 5 days of dike construction (see [BMP C121: Mulching](#)).
- Slopes 5 - 40%: Dependent on runoff velocities and dike materials. Stabilization should be done immediately using either sod or riprap or other measures to avoid erosion.
- The upslope side of the dike shall provide positive drainage to the dike outlet. No erosion shall occur at the outlet. Provide energy dissipation measures as necessary. Sediment-laden runoff must be released through a sediment trapping facility.
- Minimize construction traffic over temporary dikes. Use temporary cross culverts for channel crossing.

Interceptor swales shall meet the following criteria:

- Bottom Width: 2 feet minimum; the cross-section bottom shall be level.
- Depth: 1-foot minimum.
- Side Slope: 2H:1V or flatter.
- Grade: Maximum 5 percent, with positive drainage to a suitable outlet (such as a sediment pond).
- Stabilization: Seed as per [BMP C120: Temporary and Permanent Seeding](#), or [BMP C202: Channel Lining](#), 12 inches thick riprap pressed into the bank and extending at least 8 inches vertical from the bottom.

Inspect diversion dikes and interceptor swales once a week and after every rainfall. Immediately remove sediment from the flow area.

Damage caused by construction traffic or other activity must be repaired before the end of each working day.

Check outlets and make timely repairs as needed to avoid gully formation. When the area below the temporary diversion dike is permanently stabilized, remove the dike and fill and stabilize the channel to blend with the natural surface.

Washington State Department of Ecology

[2012 Stormwater Management Manual for Western Washington, as Amended in December 2014 \(The 2014 SWMMWW\)](#)

BMP C202: Riprap Channel Lining

Purpose

To protect channels by providing a channel liner using riprap.

Conditions of Use

Use this BMP when natural soils or vegetated stabilized soils in a channel are not adequate to prevent channel erosion.

Use this BMP when a permanent ditch or pipe system is to be installed and a temporary measure is needed.

An alternative to riprap channel lining is [BMP C122: Nets and Blankets](#).

The Federal Highway Administration recommends not using geotextile liners whenever the slope exceeds 10 percent or the shear stress exceeds 8 lbs/ft².

Design and Installation Specifications

- Since riprap is typically used where erosion potential is high, construction must be sequenced so that the riprap is put in place with the minimum possible delay.
- Disturb areas awaiting riprap only when final preparation and placement of the riprap can follow immediately behind the initial disturbance. Where riprap is used for outlet protection, the riprap should be placed before or in conjunction with the construction of the pipe or channel so that it is in place when the pipe or channel begins to operate.
- The designer, after determining the riprap size that will be stable under the flow conditions, shall consider that size to be a minimum size and then, based on riprap gradations actually available in the area, select the size or sizes that equal or exceed the minimum size. The possibility of drainage structure damage by others shall be considered in selecting a riprap size, especially if there is nearby water or a gully in which to toss the stones.
- Stone for riprap shall consist of field stone or quarry stone of approximately rectangular shape. The stone shall be hard and angular and of such quality that it will not disintegrate on exposure to water or weathering and it shall be suitable in all respects for the purpose intended. See Section 9-13 of WSDOT's *Standard Specifications for Road, Bridge, and Municipal Construction* ([WSDOT, 2016](#)).
- A lining of engineering filter fabric (geotextile) shall be placed between the riprap and the underlying soil surface to prevent soil movement into or through the riprap. The geotextile should be keyed in at the top of the bank.

- Filter fabric shall not be used on slopes greater than 1.5H:1V as slippage may occur. It should be used in conjunction with a layer of coarse aggregate (granular filter blanket) when the riprap to be placed is 12 inches and larger.

Maintenance Standards

Replace riprap as needed.

Washington State Department of Ecology

2019 Stormwater Management Manual for Western Washington (2019 SWMMWW)

Publication No.19-10-021

BMP C204: Pipe Slope Drains

Purpose

The purpose of pipe slope drains is to prevent gullies, channel erosion, and saturation of slide-prone soils by using a pipe to convey stormwater away from or over bare soil.

Conditions of Use

Pipe slope drains should be used when a temporary or permanent stormwater conveyance is needed to move water down a steep slope to avoid erosion.

Pipe slope drains should be used at bridge ends to collect runoff and convey it to the base of the fill slopes along the bridge approaches. Another use on road projects is to collect runoff from pavement in a pipe slope drain and convey it away from side slopes.

Temporary installations of pipe slope drains can be useful because there is generally a time lag between having the first lift of asphalt installed and the curbs, gutters, and permanent drainage installed. Used in conjunction with sand bags, or other temporary diversion devices, these will prevent massive amounts of sediment from leaving a project.

Pipe slope drains can serve the following purposes:

- Connection to new catch basins and temporarily use until permanent piping is installed.
- Drainage of water collected from aquifers exposed on cut slopes and conveyance of water to the base of the slope.
- Collection of clean runoff from plastic sheeting and routing the runoff away from exposed soil.
- Installation in conjunction with silt fence to drain collected water to a controlled area.
- Diversion of small seasonal streams away from construction. They have been used successfully on culvert replacement and extension jobs. Large flex pipe can be used on larger streams during culvert removal, repair, or replacement.
- Connection to existing downspouts and roof drains and diversion of water away from work areas during building renovation, demolition, and construction projects.

There are several commercially available collectors that attach to the pipe inlet and help prevent erosion at the inlet.

Design and Installation Specifications

See [Figure II-3.13: Pipe Slope Drain](#).

Size the pipe to convey the projected flow. The capacity for temporary drains shall be sufficient to handle flows calculated by one of the following methods:

- Single Event Hydrograph Method: The peak volumetric flow rate calculated using a 10-minute time step from a Type 1A, 10-year, 24-hour frequency storm for the worst-case land cover condition.

OR

- Continuous Simulation Method: The 10-year peak flow rate, as determined by an approved continuous runoff model with a 15-minute time step for the worst-case land cover condition.

Worst-case land cover conditions (i.e., producing the most runoff) should be used for analysis (in most cases, this would be the land cover conditions just prior to final landscaping).

Consult local drainage requirements for sizing permanent pipe slope drains.

- Use care in clearing vegetated slopes for installation.
- Re-establish cover immediately on areas disturbed by installation.
- Use temporary drains on new cut or fill slopes.
- Use [BMP C200: Interceptor Dike and Swale](#) to collect water at the top of the slope.
- Ensure that the entrance area is stable and large enough to direct flow into the pipe.
- Piping of water through the berm at the entrance area is a common failure mode.
- The entrance shall consist of a standard flared end section for culverts 12 inches and larger with a minimum 6-inch metal toe plate to prevent runoff from undercutting the pipe inlet. The slope of the entrance shall be at least 3 percent. Sand bags may also be used at pipe entrances as a temporary measure.
- The soil around and under the pipe and entrance section shall be thoroughly compacted to prevent undercutting.
- The flared inlet section shall be securely connected to the slope drain and have watertight connecting bands.
- Slope drain sections shall be securely fastened together, fused or have gasketed watertight fittings, and shall be securely anchored into the soil.
- Thrust blocks should be installed anytime 90 degree bends are utilized. Depending on size of pipe and flow, these can be constructed with sand bags, straw bales staked in place, “t” posts and wire, or ecology blocks.
- Pipe needs to be secured along its full length to prevent movement. This can be done with steel “t” posts and wire. Install a post on each side of the pipe and wire the pipe to them. This should be done every 10-20 feet of pipe length or so, depending on the size of the pipe and quantity of water to divert.

- [BMP C200: Interceptor Dike and Swale](#) shall be used to direct runoff into a pipe slope drain. The height of the dike shall be at least 1 foot higher at all points than the top of the inlet pipe.
- The area below the outlet must be stabilized. See [BMP C209: Outlet Protection](#).
- If the pipe slope drain is conveying sediment-laden water, direct all flows into a sediment trapping facility.
- Materials specifications for any permanent piped system shall be set by the local government.

Maintenance Standards

Check inlet and outlet points regularly, especially after storms.

- The inlet should be free of undercutting, and no water should be going around the point of entry. If there are problems, the headwall should be reinforced with compacted earth or sand bags.
- The outlet point should be free of erosion and installed with appropriate outlet protection.

For permanent installations, inspect the pipe periodically for vandalism and physical distress such as slides and wind-throw. Clean the pipe and outlet structure at the completion of construction.

Normally the pipe slope is so steep that clogging is not a problem with smooth wall pipe, however, debris may become lodged in the pipe.

Figure II-3.13: Pipe Slope Drain

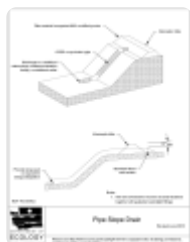

[pdf download](#)

Washington State Department of Ecology

2019 Stormwater Management Manual for Western Washington (2019 SWMMWW)

Publication No.19-10-021

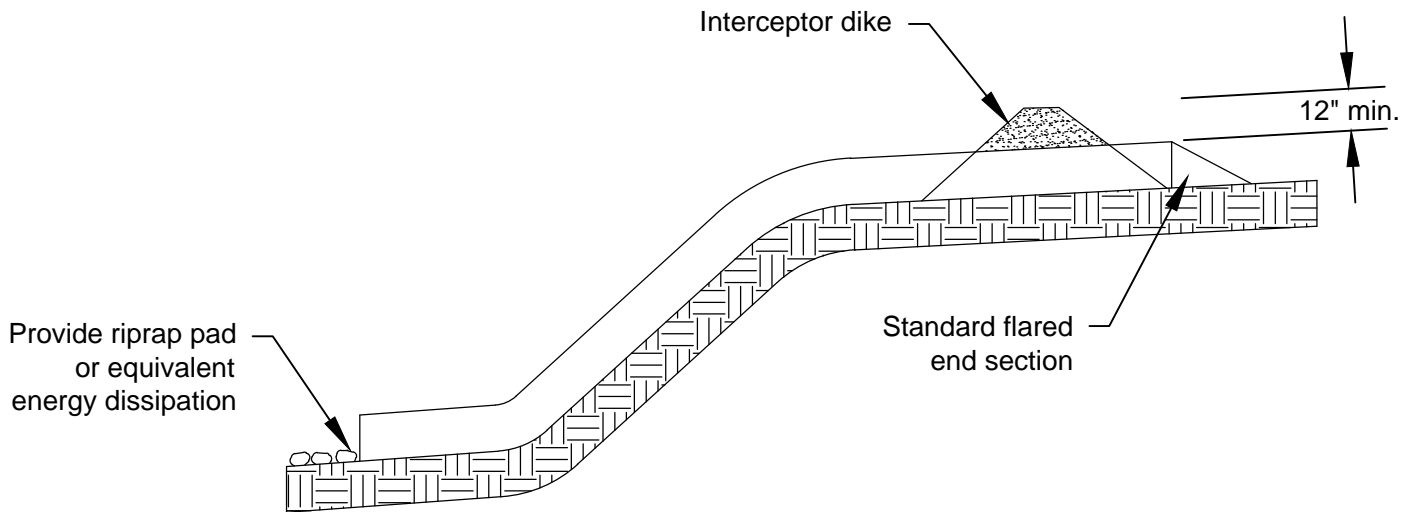
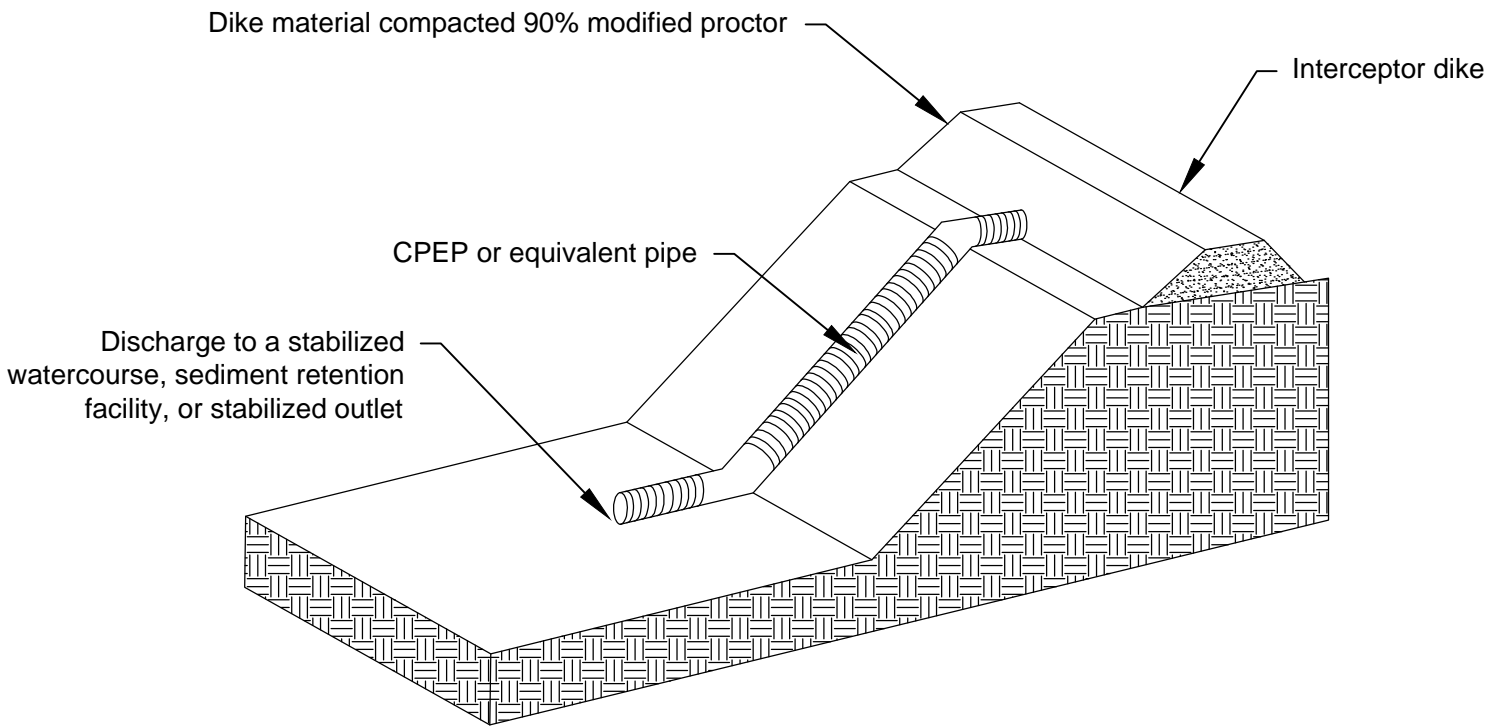

Notes:

1. Inlet and all sections must be securely fastened together with gasketed watertight fittings

NOT TO SCALE



Pipe Slope Drain

Revised June 2016

Please see <http://www.ecy.wa.gov/copyright.html> for copyright notice including permissions, limitation of liability, and disclaimer.

BMP C205: Subsurface Drains

Purpose

To intercept, collect, and convey ground water to a satisfactory outlet, using a perforated pipe or conduit below the ground surface. Subsurface drains are also known as “french drains.” The perforated pipe provides a dewatering mechanism to drain excessively wet soils, provide a stable base for construction, improve stability of structures with shallow foundations, or to reduce hydrostatic pressure to improve slope stability.

Conditions of Use

Use when excessive water must be removed from the soil. The soil permeability, depth to water table and impervious layers are all factors which may govern the use of subsurface drains.

Design and Installation Specifications

Relief drains are used either to lower the water table in large, relatively flat areas, improve the growth of vegetation, or to remove surface water.

Relief drains are installed along a slope and drain in the direction of the slope.

They can be installed in a grid pattern, a herringbone pattern, or a random pattern.

- **Interceptor drains** are used to remove excess ground water from a slope, stabilize steep slopes, and lower the water table immediately below a slope to prevent the soil from becoming saturated.

Interceptor drains are installed perpendicular to a slope and drain to the side of the slope.

They usually consist of a single pipe or series of single pipes instead of a patterned layout.

- **Depth and spacing of interceptor drains** - The depth of an interceptor drain is determined primarily by the depth to which the water table is to be lowered or the depth to a confining layer. For practical reasons, the maximum depth is usually limited to 6 feet, with a minimum cover of 2 feet to protect the conduit.
- The soil should have depth and sufficient permeability to permit installation of an effective drainage system at a depth of 2 to 6 feet.
- An adequate outlet for the drainage system must be available either by gravity or by pumping.

- The quantity and quality of discharge needs to be accounted for in the receiving stream (additional detention may be required).
- This standard does not apply to subsurface drains for building foundations or deep excavations.
- The capacity of an interceptor drain is determined by calculating the maximum rate of ground water flow to be intercepted. Therefore, it is good practice to make complete subsurface investigations, including hydraulic conductivity of the soil, before designing a subsurface drainage system.
- **Size of drain** - Size subsurface drains to carry the required capacity without pressure flow. Minimum diameter for a subsurface drain is 4 inches.
- The minimum velocity required to prevent silting is 1.4 ft./sec. The line shall be graded to achieve this velocity at a minimum. The maximum allowable velocity using a sand-gravel filter or envelope is 9 ft/sec.
- Filter material and fabric shall be used around all drains for proper bedding and filtration of fine materials. Envelopes and filters should surround the drain to a minimum of 3-inch thickness.
- The outlet of the subsurface drain shall empty into a sediment pond through a catch basin. If free of sediment, it can then empty into a receiving channel, swale, or stable vegetated area adequately protected from erosion and undermining.
- The trench shall be constructed on a continuous grade with no reverse grades or low spots.
- Soft or yielding soils under the drain shall be stabilized with gravel or other suitable material.
- Backfilling shall be done immediately after placement of the pipe. No sections of pipe shall remain uncovered overnight or during a rainstorm. Backfill material shall be placed in the trench in such a manner that the drain pipe is not displaced or damaged.
- Do not install permanent drains near trees to avoid the tree roots that tend to clog the line. Use solid pipe with watertight connections where it is necessary to pass a subsurface drainage system through a stand of trees.
- **Outlet** - Ensure that the outlet of a drain empties into a channel or other watercourse above the normal water level.
- Secure an animal guard to the outlet end of the pipe to keep out rodents.
- Use outlet pipe of corrugated metal, cast iron, or heavy-duty plastic without perforations and at least 10 feet long. Do not use an envelope or filter material around the outlet pipe, and bury at

least two-thirds of the pipe length.

- When outlet velocities exceed those allowable for the receiving stream, outlet protection must be provided.

Maintenance Standards

Subsurface drains shall be checked periodically to ensure that they are free-flowing and not clogged with sediment or roots.

- The outlet shall be kept clean and free of debris.
- Surface inlets shall be kept open and free of sediment and other debris.
- Trees located too close to a subsurface drain often clog the system with their roots. If a drain becomes clogged, relocate the drain or remove the trees as a last resort. Drain placement should be planned to minimize this problem.
- Where drains are crossed by heavy vehicles, the line shall be checked to ensure that it is not crushed.

Washington State Department of Ecology

[2012 Stormwater Management Manual for Western Washington, as Amended in December 2014 \(The 2014 SWMMWW\)](#)

BMP C207: Check Dams

Purpose

Construction of small dams across a swale or ditch reduces the velocity of concentrated flow and dissipates energy at the check dam.

Conditions of Use

Where temporary channels or permanent channels are not yet vegetated, channel lining is infeasible, and/or velocity checks are required.

- Check dams may not be placed in streams unless approved by the State Department of Fish and Wildlife. Check dams may not be placed in wetlands without approval from a permitting agency.
- Do not place check dams below the expected backwater from any salmonid bearing water between October 1 and May 31 to ensure that there is no loss of high flow refuge habitat for overwintering juvenile salmonids and emergent salmonid fry.
- Construct rock check dams from appropriately sized rock. The rock used must be large enough to stay in place given the expected design flow through the channel. The rock must be placed by hand or by mechanical means (no dumping of rock to form dam) to achieve complete coverage of the ditch or swale and to ensure that the center of the dam is lower than the edges.
- Check dams may also be constructed of either rock or pea-gravel filled bags. Numerous new products are also available for this purpose. They tend to be re-usable, quick and easy to install, effective, and cost efficient.
- Place check dams perpendicular to the flow of water.
- The dam should form a triangle when viewed from the side. This prevents undercutting as water flows over the face of the dam rather than falling directly onto the ditch bottom.
- Before installing check dams impound and bypass upstream water flow away from the work area. Options for bypassing include pumps, siphons, or temporary channels.
- Check dams in association with sumps work more effectively at slowing flow and retaining sediment than just a check dam alone. A deep sump should be provided immediately upstream of the check dam.

- In some cases, if carefully located and designed, check dams can remain as permanent installations with very minor regrading. They may be left as either spillways, in which case accumulated sediment would be graded and seeded, or as check dams to prevent further sediment from leaving the site.
- The maximum spacing between the dams shall be such that the toe of the upstream dam is at the same elevation as the top of the downstream dam.
- Keep the maximum height at 2 feet at the center of the dam.
- Keep the center of the check dam at least 12 inches lower than the outer edges at natural ground elevation.
- Keep the side slopes of the check dam at 2H:1V or flatter.
- Key the stone into the ditch banks and extend it beyond the abutments a minimum of 18 inches to avoid washouts from overflow around the dam.
- Use filter fabric foundation under a rock or sand bag check dam. If a blanket ditch liner is used, filter fabric is not necessary. A piece of organic or synthetic blanket cut to fit will also work for this purpose.
- In the case of grass-lined ditches and swales, all check dams and accumulated sediment shall be removed when the grass has matured sufficiently to protect the ditch or swale - unless the slope of the swale is greater than 4 percent. The area beneath the check dams shall be seeded and mulched immediately after dam removal.
- Ensure that channel appurtenances, such as culvert entrances below check dams, are not subject to damage or blockage from displaced stones. [Figure II-4.2.7 Rock Check Dam](#) depicts a typical rock check dam.

Maintenance Standards

Check dams shall be monitored for performance and sediment accumulation during and after each runoff producing rainfall. Sediment shall be removed when it reaches one half the sump depth.

- Anticipate submergence and deposition above the check dam and erosion from high flows around the edges of the dam.
- If significant erosion occurs between dams, install a protective riprap liner in that portion of the channel.

Approved as Equivalent

Ecology has approved products as able to meet the requirements of [BMP C207: Check Dams](#). The products did not pass through the Technology Assessment Protocol – Ecology (TAPE) process. Local jurisdictions may choose not to accept this product approved as equivalent, or may require additional testing prior to consideration for local use. The products are available for review on Ecology's website at <http://www.ecy.wa.gov/programs/wq/stormwater/newtech/equivalent.html>

Figure II-4.2.7 Rock Check Dam

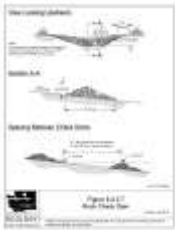

[2014 Figure II-4.2.7 pdf download](#)

Washington State Department of Ecology

[2012 Stormwater Management Manual for Western Washington, as Amended in December 2014. \(The 2014 SWMMWW\)](#)

View Looking Upstream

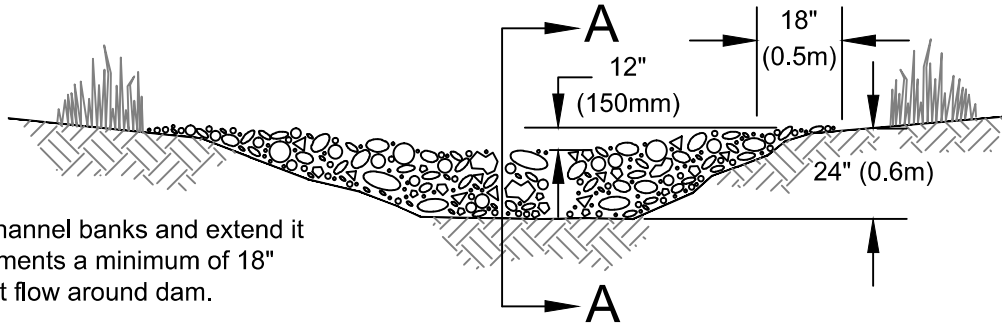

Note:
Key stone into channel banks and extend it
beyond the abutments a minimum of 18"
(0.5m) to prevent flow around dam.

Section A-A

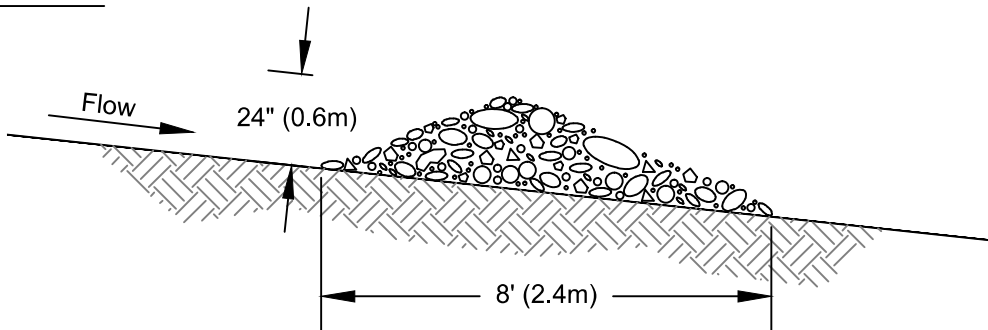

Spacing Between Check Dams

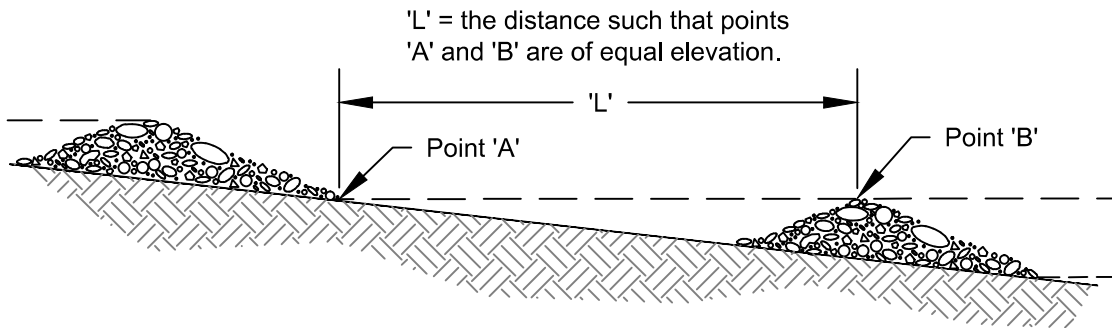

NOT TO SCALE



DEPARTMENT OF
ECOLOGY
State of Washington

Figure II-4.2.7 Rock Check Dam

Revised July 2015

Please see <http://www.ecy.wa.gov/copyright.html> for copyright notice including permissions, limitation of liability, and disclaimer.

BMP C209: Outlet Protection

Purpose

Outlet protection prevents scour at conveyance outlets and minimizes the potential for downstream erosion by reducing the velocity of concentrated stormwater flows.

Conditions of Use

Use outlet protection at the outlets of all ponds, pipes, ditches, or other conveyances that discharge to a natural or manmade drainage feature such as a stream, wetland, lake, or ditch.

Design and Installation Specifications

- The receiving channel at the outlet of a pipe shall be protected from erosion by lining a minimum of 6 feet downstream and extending up the channel sides a minimum of 1-foot above the maximum tailwater elevation, or 1-foot above the crown, whichever is higher. For pipes larger than 18 inches in diameter, the outlet protection lining of the channel shall be four times the diameter of the outlet pipe.
- Standard wingwalls, tapered outlets, and paved channels should also be considered when appropriate for permanent culvert outlet protection ([WSDOT, 2015](#)).
- [BMP C122: Nets and Blankets](#) or [BMP C202: Riprap Channel Lining](#) provide suitable options for lining materials.
- With low flows, [BMP C201: Grass-Lined Channels](#) can be an effective alternative for lining material.
- The following guidelines shall be used for outlet protection with riprap:
 - If the discharge velocity at the outlet is less than 5 fps, use 2-inch to 8-inch riprap. Minimum thickness is 1-foot.
 - For 5 to 10 fps discharge velocity at the outlet, use 24-inch to 48-inch riprap. Minimum thickness is 2 feet.
 - For outlets at the base of steep slope pipes (pipe slope greater than 10 percent), use an engineered energy dissipator.
 - Filter fabric or erosion control blankets should always be used under riprap to prevent scour and channel erosion. See [BMP C122: Nets and Blankets](#).
- Bank stabilization, bioengineering, and habitat features may be required for disturbed areas. This work may require a Hydraulic Project Approval (HPA) from the Washington State Department of Fish and Wildlife. See

Maintenance Standards

- Inspect and repair as needed.
- Add rock as needed to maintain the intended function.
- Clean energy dissipator if sediment builds up.

Washington State Department of Ecology

2019 Stormwater Management Manual for Western Washington (2019 SWMMWW)

Publication No.19-10-021

BMP C220: Storm Drain Inlet Protection

Purpose To prevent coarse sediment from entering drainage systems prior to permanent stabilization of the disturbed area.

Conditions of Use Where storm drain inlets are to be made operational before permanent stabilization of the disturbed drainage area. Protection should be provided for all storm drain inlets downslope and within 500 feet of a disturbed or construction area, unless the runoff that enters the catch basin will be conveyed to a sediment pond or trap. Inlet protection may be used anywhere to protect the drainage system. It is likely that the drainage system will still require cleaning.

Table 4.9 lists several options for inlet protection. All of the methods for storm drain inlet protection are prone to plugging and require a high frequency of maintenance. Drainage areas should be limited to 1 acre or less. Emergency overflows may be required where stormwater ponding would cause a hazard. If an emergency overflow is provided, additional end-of-pipe treatment may be required.

Table 4.9 Storm Drain Inlet Protection			
Type of Inlet Protection	Emergency Overflow	Applicable for Paved/ Earthen Surfaces	Conditions of Use
Drop Inlet Protection			
Excavated drop inlet protection	Yes, temporary flooding will occur	Earthen	Applicable for heavy flows. Easy to maintain. Large area Requirement: 30' X 30'/acre
Block and gravel drop inlet protection	Yes	Paved or Earthen	Applicable for heavy concentrated flows. Will not pond.
Gravel and wire drop inlet protection	No		Applicable for heavy concentrated flows. Will pond. Can withstand traffic.
Catch basin filters	Yes	Paved or Earthen	Frequent maintenance required.
Curb Inlet Protection			
Curb inlet protection with a wooden weir	Small capacity overflow	Paved	Used for sturdy, more compact installation.
Block and gravel curb inlet protection	Yes	Paved	Sturdy, but limited filtration.
Culvert Inlet Protection			
Culvert inlet sediment trap			18 month expected life.

***Design and
Installation
Specifications***

Excavated Drop Inlet Protection - An excavated impoundment around the storm drain. Sediment settles out of the stormwater prior to entering the storm drain.

- Depth 1-2 ft as measured from the crest of the inlet structure.
- Side Slopes of excavation no steeper than 2:1.
- Minimum volume of excavation 35 cubic yards.
- Shape basin to fit site with longest dimension oriented toward the longest inflow area.
- Install provisions for draining to prevent standing water problems.
- Clear the area of all debris.
- Grade the approach to the inlet uniformly.
- Drill weep holes into the side of the inlet.
- Protect weep holes with screen wire and washed aggregate.
- Seal weep holes when removing structure and stabilizing area.
- It may be necessary to build a temporary dike to the down slope side of the structure to prevent bypass flow.

Block and Gravel Filter - A barrier formed around the storm drain inlet with standard concrete blocks and gravel. See Figure 4.14.

- Height 1 to 2 feet above inlet.
- Recess the first row 2 inches into the ground for stability.
- Support subsequent courses by placing a 2x4 through the block opening.
- Do not use mortar.
- Lay some blocks in the bottom row on their side for dewatering the pool.
- Place hardware cloth or comparable wire mesh with ½-inch openings over all block openings.
- Place gravel just below the top of blocks on slopes of 2:1 or flatter.
- An alternative design is a gravel donut.
- Inlet slope of 3:1.
- Outlet slope of 2:1.
- 1-foot wide level stone area between the structure and the inlet.
- Inlet slope stones 3 inches in diameter or larger.
- Outlet slope use gravel ½- to ¾-inch at a minimum thickness of 1-foot.

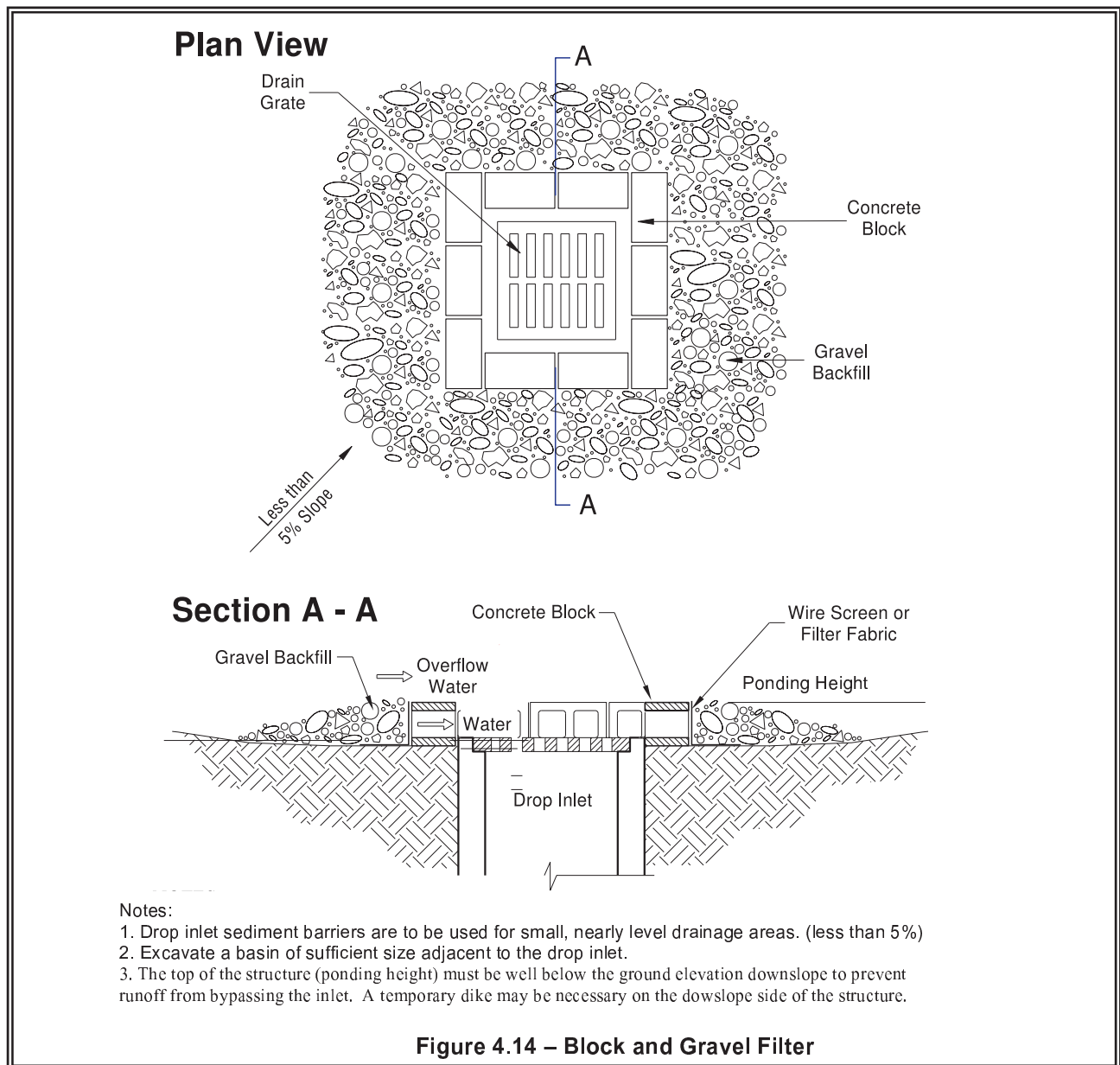

Figure 4.14 – Block and Gravel Filter

Gravel and Wire Mesh Filter - A gravel barrier placed over the top of the inlet. This structure does not provide an overflow.

- Hardware cloth or comparable wire mesh with ½-inch openings.
- Coarse aggregate.
- Height 1-foot or more, 18 inches wider than inlet on all sides.
- Place wire mesh over the drop inlet so that the wire extends a minimum of 1-foot beyond each side of the inlet structure.
- If more than one strip of mesh is necessary, overlap the strips.
- Place coarse aggregate over the wire mesh.
- The depth of the gravel should be at least 12 inches over the entire inlet opening and extend at least 18 inches on all sides.

Catchbasin Filters - Inserts should be designed by the manufacturer for use at construction sites. The limited sediment storage capacity increases the amount of inspection and maintenance required, which may be daily for heavy sediment loads. The maintenance requirements can be reduced by combining a catchbasin filter with another type of inlet protection. This type of inlet protection provides flow bypass without overflow and therefore may be a better method for inlets located along active rights-of-way.

- 5 cubic feet of storage.
- Dewatering provisions.
- High-flow bypass that will not clog under normal use at a construction site.
- The catchbasin filter is inserted in the catchbasin just below the grating.

Curb Inlet Protection with Wooden Weir – Barrier formed around a curb inlet with a wooden frame and gravel.

- Wire mesh with ½-inch openings.
- Extra strength filter cloth.
- Construct a frame.
- Attach the wire and filter fabric to the frame.
- Pile coarse washed aggregate against wire/fabric.
- Place weight on frame anchors.

Block and Gravel Curb Inlet Protection – Barrier formed around an inlet with concrete blocks and gravel. See Figure 4.14.

- Wire mesh with ½-inch openings.
- Place two concrete blocks on their sides abutting the curb at either side of the inlet opening. These are spacer blocks.
- Place a 2x4 stud through the outer holes of each spacer block to align the front blocks.
- Place blocks on their sides across the front of the inlet and abutting the spacer blocks.
- Place wire mesh over the outside vertical face.
- Pile coarse aggregate against the wire to the top of the barrier.

Curb and Gutter Sediment Barrier – Sandbag or rock berm (riprap and aggregate) 3 feet high and 3 feet wide in a horseshoe shape. See Figure 4.16.

- Construct a horseshoe shaped berm, faced with coarse aggregate if using riprap, 3 feet high and 3 feet wide, at least 2 feet from the inlet.
- Construct a horseshoe shaped sedimentation trap on the outside of the berm sized to sediment trap standards for protecting a culvert inlet.

***Maintenance
Standards***

- Catch basin filters should be inspected frequently, especially after storm events. If the insert becomes clogged, it should be cleaned or replaced.
- For systems using stone filters: If the stone filter becomes clogged with sediment, the stones must be pulled away from the inlet and cleaned or replaced. Since cleaning of gravel at a construction site may be difficult, an alternative approach would be to use the clogged stone as fill and put fresh stone around the inlet.
- Do not wash sediment into storm drains while cleaning. Spread all excavated material evenly over the surrounding land area or stockpile and stabilize as appropriate.

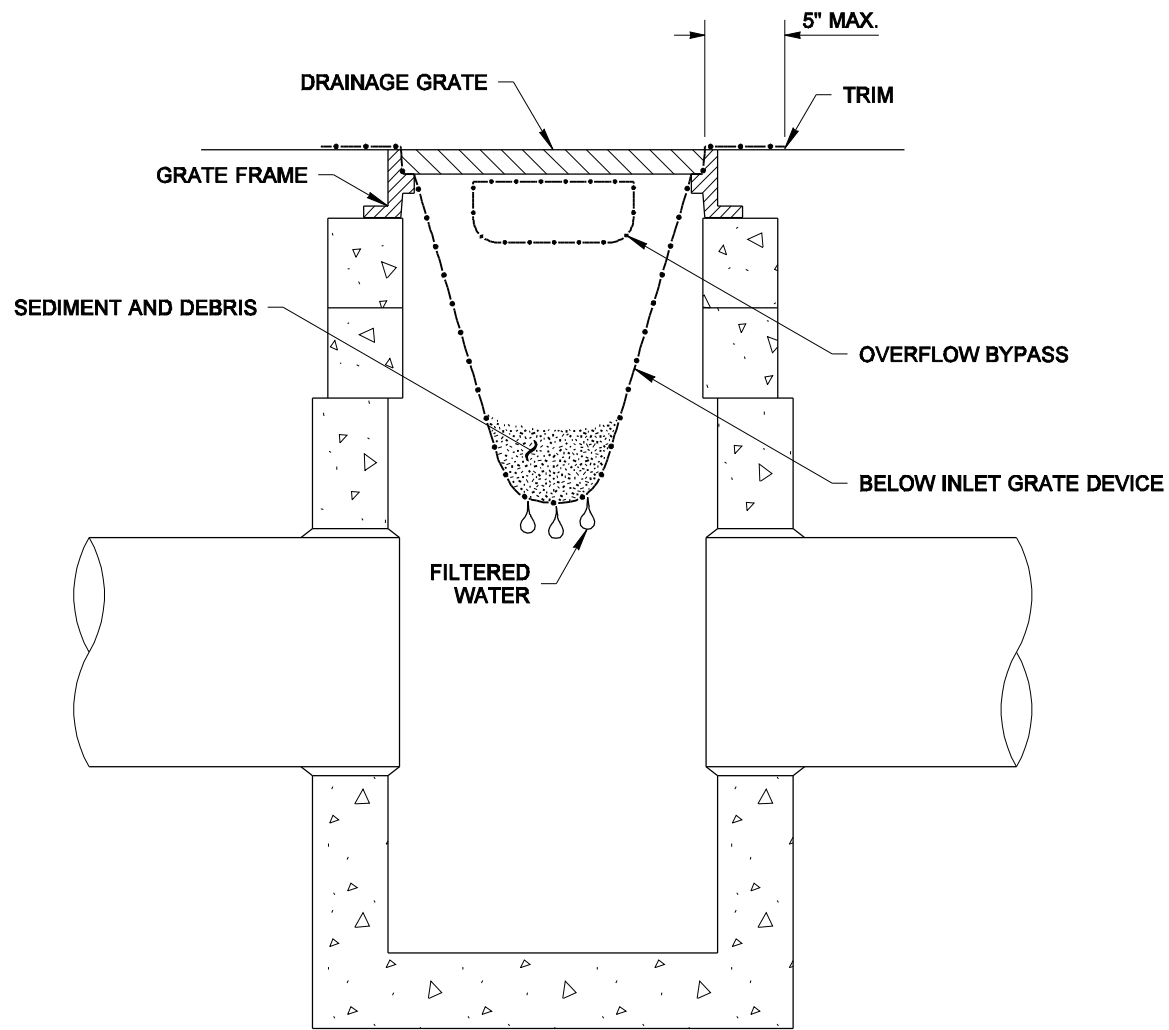

SECTION VIEW
NOT TO SCALE

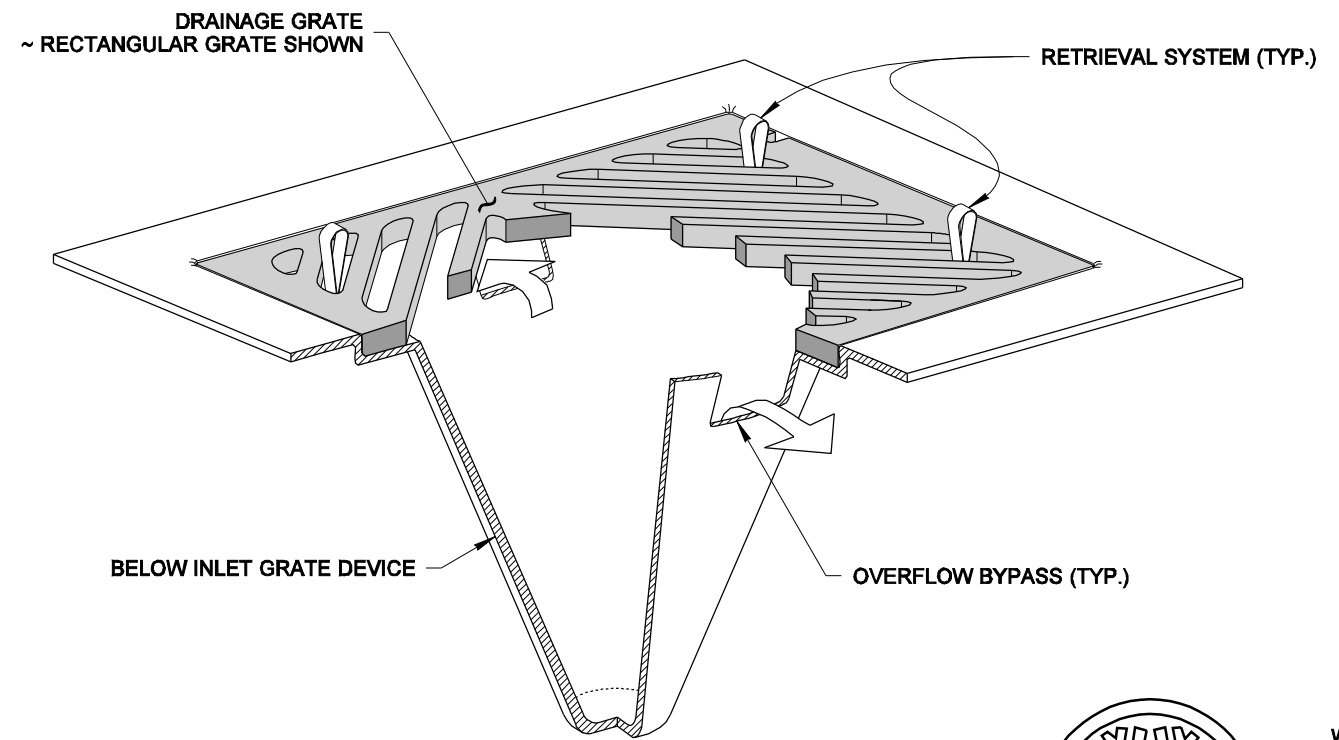

ISOMETRIC VIEW

NOTES

1. Size the Below Inlet Grate Device (BIGD) for the storm water structure it will service.
2. The BIGD shall have a built-in high-flow relief system (overflow bypass).
3. The retrieval system must allow removal of the BIGD without spilling the collected material.
4. Perform maintenance in accordance with Standard Specification 8-01.3(15).

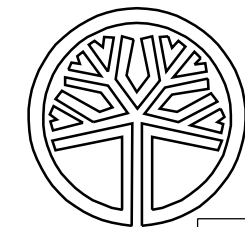

STATE OF WASHINGTON
REGISTERED
LANDSCAPE ARCHITECT

MARK W. MAURER
CERTIFICATE NO. 000598

NOTE: THIS PLAN IS NOT A LEGAL ENGINEERING DOCUMENT BUT AN ELECTRONIC DUPLICATE. THE ORIGINAL, SIGNED BY THE ENGINEER AND APPROVED FOR PUBLICATION, IS KEPT ON FILE AT THE WASHINGTON STATE DEPARTMENT OF TRANSPORTATION. A COPY MAY BE OBTAINED UPON REQUEST.

**STORM DRAIN
INLET PROTECTION
STANDARD PLAN I-40.20-00**

SHEET 1 OF 1 SHEET

APPROVED FOR PUBLICATION

Pasco Bakotich III **09-20-07**
STATE DESIGN ENGINEER DATE



BMP C231: Brush Barrier

Purpose

The purpose of brush barriers is to reduce the transport of coarse sediment from a construction site by providing a temporary physical barrier to sediment and reducing the runoff velocities of overland flow.

Conditions of Use

- Brush barriers may be used downslope of all disturbed areas of less than one-quarter acre.
- Brush barriers are not intended to treat concentrated flows, nor are they intended to treat substantial amounts of overland flow. Any concentrated flows must be conveyed through the drainage system to a sediment pond. The only circumstance in which overland flow can be treated solely by a brush barrier, rather than by a sediment pond, is when the area draining to the barrier is small.
- Brush barriers should only be installed on contours.

Design and Installation Specifications

- Height 2 feet (minimum) to 5 feet (maximum).
- Width 5 feet at base (minimum) to 15 feet (maximum).
- Filter fabric (geotextile) may be anchored over the brush berm to enhance the filtration ability of the barrier. Ten-ounce burlap is an adequate alternative to filter fabric.
- Chipped site vegetation, composted mulch, or wood-based mulch (hog fuel) can be used to construct brush barriers.
- A 100 percent biodegradable installation can be constructed using 10-ounce burlap held in place by wooden stakes. [Figure II-4.2.11 Brush Barrier](#) depicts a typical brush barrier.

Maintenance Standards

- There shall be no signs of erosion or concentrated runoff under or around the barrier. If concentrated flows are bypassing the barrier, it must be expanded or augmented by toed-in filter fabric.
- The dimensions of the barrier must be maintained.

Figure II-4.2.11 Brush Barrier



[2014 Figure II-4.2.11 pdf download](#)

Washington State Department of Ecology

[2012 Stormwater Management Manual for Western Washington, as Amended in December 2014. \(The 2014 SWMMWW\)](#)

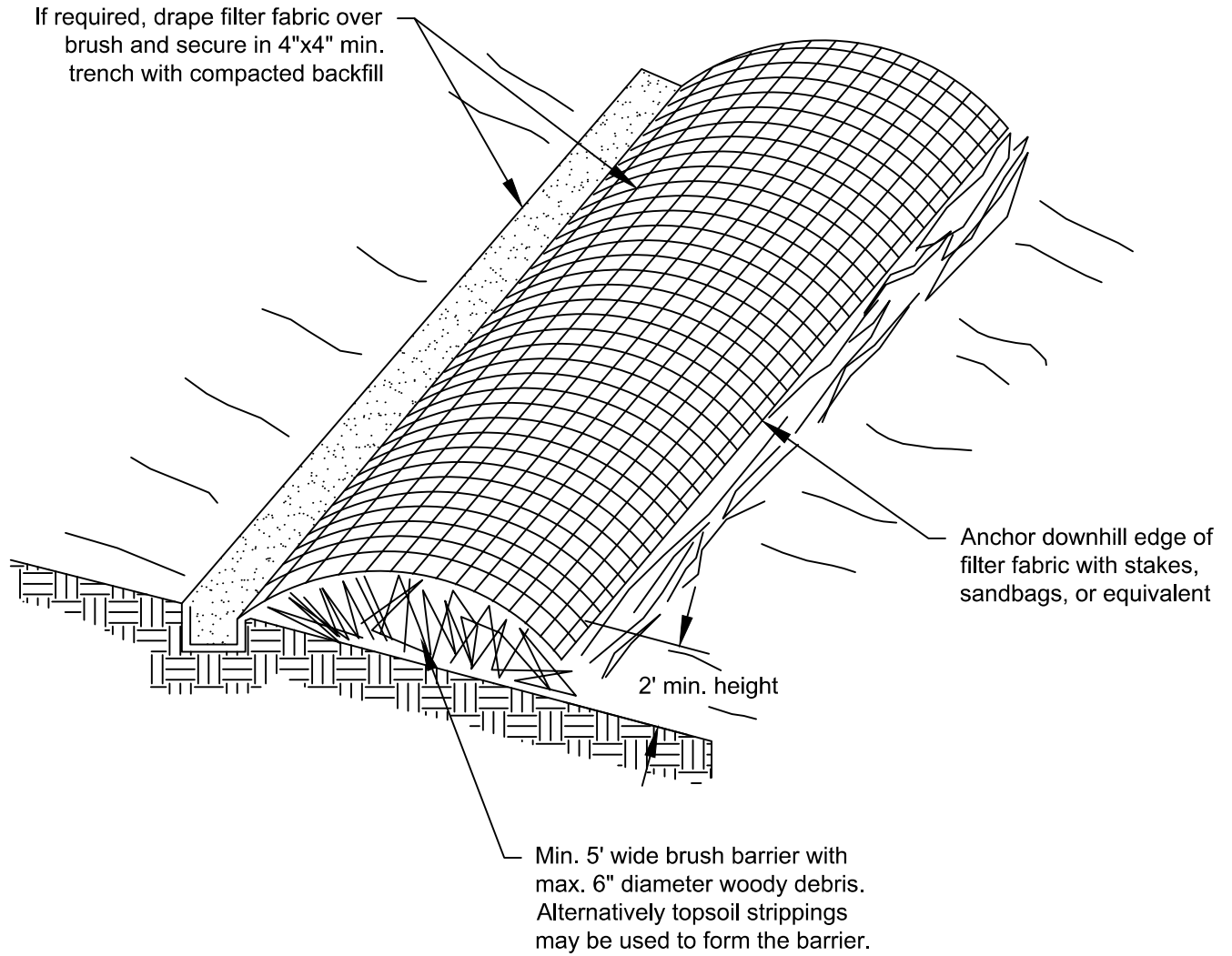

NOT TO SCALE

Figure II-4.2.11
Brush Barrier

Revised September 2015

BMP C232: Gravel Filter Berm

Purpose

A gravel filter berm is constructed on rights-of-way or traffic areas within a construction site to retain sediment by using a filter berm of gravel or crushed rock.

Conditions of Use

Where a temporary measure is needed to retain sediment from rights-of-way or in traffic areas on construction sites.

Design and Installation Specifications

- Berm material shall be $\frac{3}{4}$ to 3 inches in size, washed well-grade gravel or crushed rock with less than 5 percent fines.
- Spacing of berms:
 - Every 300 feet on slopes less than 5 percent
 - Every 200 feet on slopes between 5 percent and 10 percent
 - Every 100 feet on slopes greater than 10 percent
- Berm dimensions:
 - 1 foot high with 3H:1V side slopes
 - 8 linear feet per 1 cfs runoff based on the 10-year, 24-hour design storm

Maintenance Standards

- Regular inspection is required. Sediment shall be removed and filter material replaced as needed.

Washington State Department of Ecology

[2012 Stormwater Management Manual for Western Washington, as Amended in December 2014 \(The 2014 SWMMWW\)](#)

BMP C233: Silt Fence

Purpose

Use of a silt fence reduces the transport of coarse sediment from a construction site by providing a temporary physical barrier to sediment and reducing the runoff velocities of overland flow. See Figure 4.19 for details on silt fence construction.

Conditions of Use

Silt fence may be used downslope of all disturbed areas.

- Silt fence is not intended to treat concentrated flows, nor is it intended to treat substantial amounts of overland flow. Any concentrated flows must be conveyed through the drainage system to a sediment pond. The only circumstance in which overland flow can be treated solely by a silt fence, rather than by a sediment pond, is when the area draining to the fence is one acre or less and flow rates are less than 0.5 cfs.
- Silt fences should not be constructed in streams or used in V-shaped ditches. They are not an adequate method of silt control for anything deeper than sheet or overland flow.

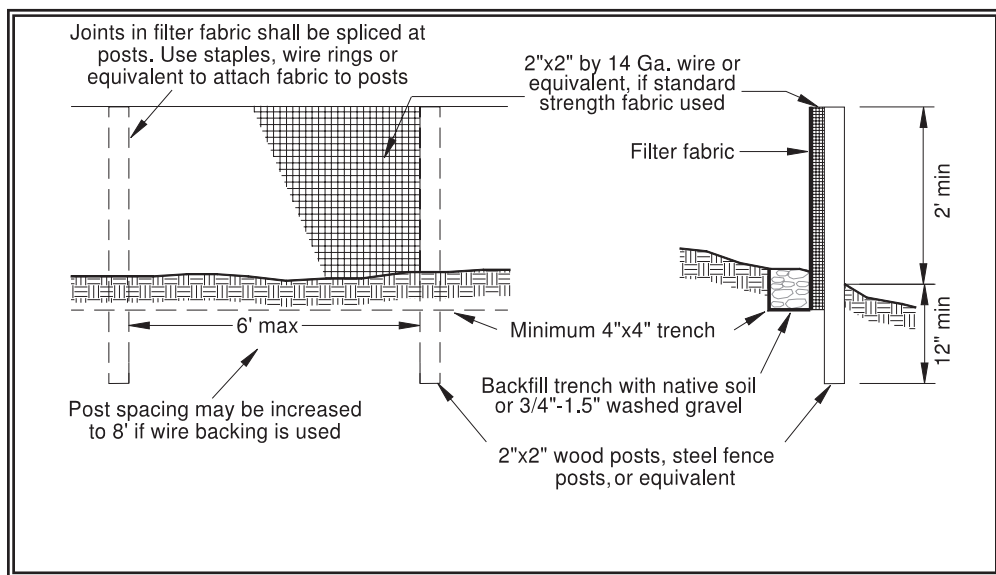

Figure 4.19 – Silt Fence

Design and Installation Specifications

- Drainage area of 1 acre or less or in combination with sediment basin in a larger site.
- Maximum slope steepness (normal (perpendicular) to fence line) 1:1.
- Maximum sheet or overland flow path length to the fence of 100 feet.
- No flows greater than 0.5 cfs.
- The geotextile used shall meet the following standards. All geotextile properties listed below are minimum average roll values (i.e., the test result for any sampled roll in a lot shall meet or exceed the values shown in Table 4.10):

Polymeric Mesh AOS (ASTM D4751)	0.60 mm maximum for slit film wovens (#30 sieve). 0.30 mm maximum for all other geotextile types (#50 sieve). 0.15 mm minimum for all fabric types (#100 sieve).
Water Permittivity (ASTM D4491)	0.02 sec ⁻¹ minimum
Grab Tensile Strength (ASTM D4632)	180 lbs. Minimum for extra strength fabric. 100 lbs minimum for standard strength fabric.
Grab Tensile Strength (ASTM D4632)	30% maximum
Ultraviolet Resistance (ASTM D4355)	70% minimum

- Standard strength fabrics shall be supported with wire mesh, chicken wire, 2-inch x 2-inch wire, safety fence, or jute mesh to increase the strength of the fabric. Silt fence materials are available that have synthetic mesh backing attached.
- Filter fabric material shall contain ultraviolet ray inhibitors and stabilizers to provide a minimum of six months of expected usable construction life at a temperature range of 0°F. to 120°F.
- 100 percent biodegradable silt fence is available that is strong, long lasting, and can be left in place after the project is completed, if permitted by local regulations.
- Standard Notes for construction plans and specifications follow. Refer to Figure 4.19 for standard silt fence details.

The contractor shall install and maintain temporary silt fences at the locations shown in the Plans. The silt fences shall be constructed in the areas of clearing, grading, or drainage prior to starting those activities. A silt fence shall not be considered temporary if the silt fence must function beyond the life of the contract. The silt fence shall prevent soil carried by runoff water from going beneath, through, or over the top of the silt fence, but shall allow the water to pass through the fence.

The minimum height of the top of silt fence shall be 2 feet and the maximum height shall be 2½ feet above the original ground surface.

The geotextile shall be sewn together at the point of manufacture, or at an approved location as determined by the Engineer, to form geotextile lengths as required. All sewn seams shall be located at a support post. Alternatively, two sections of silt fence can be overlapped, provided the Contractor can demonstrate, to the satisfaction of the Engineer, that the overlap is long enough and that the adjacent fence sections are close enough together to prevent silt laden water from escaping through the fence at the overlap.

The geotextile shall be attached on the up-slope side of the posts and support system with staples, wire, or in accordance with the manufacturer's recommendations. The geotextile shall be attached to the posts in a manner that reduces the potential for geotextile tearing at the staples, wire, or other connection device. Silt fence back-up support for the geotextile in the form of a wire or plastic mesh is dependent on the properties of the geotextile selected for use. If wire or plastic back-up mesh is used, the mesh shall be fastened securely to the up-slope of the posts with the geotextile being up-slope of the mesh back-up support.

The geotextile at the bottom of the fence shall be buried in a trench to a minimum depth of 4 inches below the ground surface. The trench shall be backfilled and the soil tamped in place over the buried portion of the geotextile, such that no flow can pass beneath the fence and scouring can not occur. When wire or polymeric back-up support mesh is used, the wire or polymeric mesh shall extend into the trench a minimum of 3 inches.

The fence posts shall be placed or driven a minimum of 18 inches. A minimum depth of 12 inches is allowed if topsoil or other soft subgrade soil is not present and a minimum depth of 18 inches cannot be reached. Fence post depths shall be increased by 6 inches if the fence is located on slopes of 3:1 or steeper and the slope is perpendicular to the fence. If required post depths cannot be obtained, the posts shall be adequately secured by bracing or guying to prevent overturning of the fence due to sediment loading.

Silt fences shall be located on contour as much as possible, except at the ends of the fence, where the fence shall be turned uphill such that the silt fence captures the runoff water and prevents water from flowing around the end of the fence.

If the fence must cross contours, with the exception of the ends of the fence, gravel check dams placed perpendicular to the back of the fence shall be used to minimize concentrated flow and erosion along the back of the fence. The gravel check dams shall be approximately 1-foot deep at the back of the fence. It shall be continued perpendicular to the fence at the same elevation until the top of the check dam intercepts the ground surface behind the fence. The gravel check dams shall consist of crushed surfacing base course, gravel backfill for walls, or shoulder ballast. The gravel check dams shall be located every 10 feet along the fence where the fence must cross contours. The slope of the fence line where contours must be crossed shall not be steeper than 3:1.

Wood, steel or equivalent posts shall be used. Wood posts shall have minimum dimensions of 2 inches by 2 inches by 3 feet minimum length, and shall be free of defects such as knots, splits, or gouges.

Steel posts shall consist of either size No. 6 rebar or larger, ASTM A 120 steel pipe with a minimum diameter of 1-inch, U, T, L, or C shape steel posts with a minimum weight of 1.35 lbs./ft. or other steel posts having equivalent strength and bending resistance to the post sizes listed. The spacing of the support posts shall be a maximum of 6 feet.

Fence back-up support, if used, shall consist of steel wire with a maximum mesh spacing of 2 inches, or a prefabricated polymeric mesh. The strength of the wire or polymeric mesh shall be equivalent to or greater than 180 lbs. grab tensile strength. The polymeric mesh must be as resistant to ultraviolet radiation as the geotextile it supports.

- Silt fence installation using the slicing method specification details follow. Refer to Figure 4.20 for slicing method details.

The base of both end posts must be at least 2 to 4 inches above the top of the silt fence fabric on the middle posts for ditch checks to drain properly. Use a hand level or string level, if necessary, to mark base points before installation.

Install posts 3 to 4 feet apart in critical retention areas and 6 to 7 feet apart in standard applications.

Install posts 24 inches deep on the downstream side of the silt fence, and as close as possible to the fabric, enabling posts to support the fabric from upstream water pressure.

Install posts with the nipples facing away from the silt fence fabric.

Attach the fabric to each post with three ties, all spaced within the top 8 inches of the fabric. Attach each tie diagonally 45 degrees through the fabric, with each puncture at least 1 inch vertically apart. In addition, each tie should be positioned to hang on a post nipple when tightening to prevent sagging.

Wrap approximately 6 inches of fabric around the end posts and secure with 3 ties.

No more than 24 inches of a 36-inch fabric is allowed above ground level.

The rope lock system must be used in all ditch check applications.

The installation should be checked and corrected for any deviation before compaction. Use a flat-bladed shovel to tuck fabric deeper into the ground if necessary.

Compaction is vitally important for effective results. Compact the soil immediately next to the silt fence fabric with the front wheel of the tractor, skid steer, or roller exerting at least 60 pounds per square inch. Compact the upstream side first and then each side twice for a total of four trips.

Maintenance Standards

- Any damage shall be repaired immediately.
- If concentrated flows are evident uphill of the fence, they must be intercepted and conveyed to a sediment pond.
- It is important to check the uphill side of the fence for signs of the fence clogging and acting as a barrier to flow and then causing channelization of flows parallel to the fence. If this occurs, replace the fence or remove the trapped sediment.
- Sediment deposits shall either be removed when the deposit reaches approximately one-third the height of the silt fence, or a second silt fence shall be installed.
- If the filter fabric (geotextile) has deteriorated due to ultraviolet breakdown, it shall be replaced.

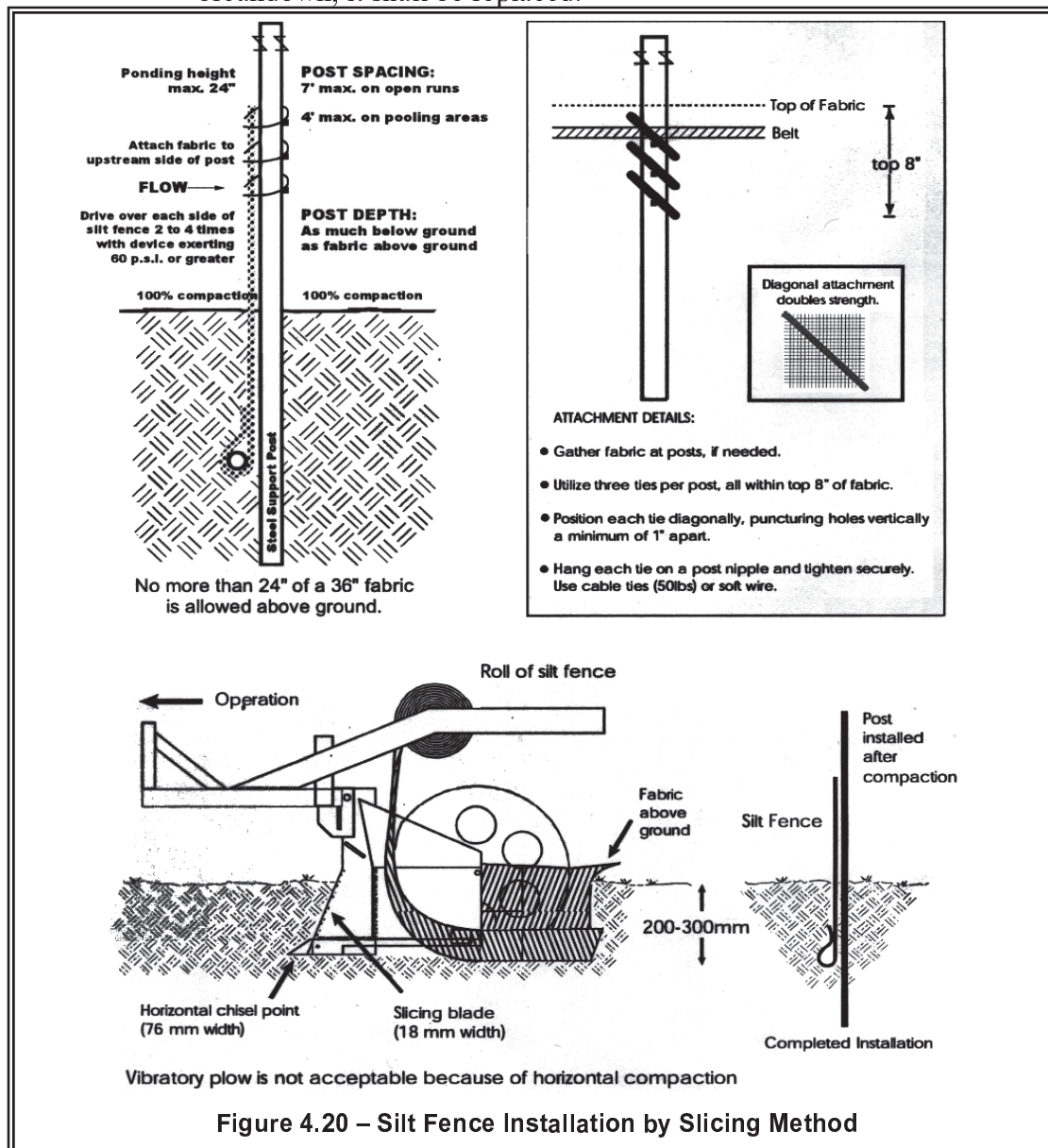

BMP C234: Vegetated Strip

Purpose

Vegetated strips reduce the transport of coarse sediment from a construction site by providing a temporary physical barrier to sediment and reducing the runoff velocities of overland flow.

Conditions of Use

- Vegetated strips may be used downslope of all disturbed areas.
- Vegetated strips are not intended to treat concentrated flows, nor are they intended to treat substantial amounts of overland flow. Any concentrated flows must be conveyed through the drainage system to a sediment pond. The only circumstance in which overland flow can be treated solely by a strip, rather than by a sediment pond, is when the following criteria are met (see [Table II-4.2.4 Contributing Drainage Area for Vegetated Strips](#)):

Table II-4.2.4 Contributing Drainage Area for Vegetated Strips

Average Contributing Area Slope	Average Contributing Area Percent Slope	Max Contributing area Flowpath Length
1.5H : 1V or flatter	67% or flatter	100 feet
2H : 1V or flatter	50% or flatter	115 feet
4H : 1V or flatter	25% or flatter	150 feet
6H : 1V or flatter	16.7% or flatter	200 feet
10H : 1V or flatter	10% or flatter	250 feet

Design and Installation Specifications

- The vegetated strip shall consist of a minimum of a 25-foot flowpath length continuous strip of dense vegetation with topsoil. Grass-covered, landscaped areas are generally not adequate because the volume of sediment overwhelms the grass. Ideally, vegetated strips shall consist of undisturbed native growth with a well-developed soil that allows for infiltration of runoff.
- The slope within the strip shall not exceed 4H:1V.
- The uphill boundary of the vegetated strip shall be delineated with clearing limits.

Maintenance Standards

- Any areas damaged by erosion or construction activity shall be seeded immediately and protected by mulch.

- If more than 5 feet of the original vegetated strip width has had vegetation removed or is being eroded, sod must be installed.
- If there are indications that concentrated flows are traveling across the buffer, surface water controls must be installed to reduce the flows entering the buffer, or additional perimeter protection must be installed.

Washington State Department of Ecology

[2012 Stormwater Management Manual for Western Washington, as Amended in December 2014 \(The 2014 SWMMWW\)](#)

BMP C235: Wattles

Purpose

Wattles are temporary erosion and sediment control barriers consisting of straw, compost, or other material that is wrapped in biodegradable tubular plastic or similar encasing material. They reduce the velocity and can spread the flow of rill and sheet runoff, and can capture and retain sediment. Wattles are typically 8 to 10 inches in diameter and 25 to 30 feet in length. Wattles are placed in shallow trenches and staked along the contour of disturbed or newly constructed slopes. See [Figure II-4.2.14 Wattles](#) for typical construction details. WSDOT Standard Plan I-30.30-00 also provides information on Wattles (<http://www.wsdot.wa.gov/Design/Standards/Plans.htm#SectionI>)

Conditions of Use

- Use wattles:
 - In disturbed areas that require immediate erosion protection.
 - On exposed soils during the period of short construction delays, or over winter months.
 - On slopes requiring stabilization until permanent vegetation can be established.
- The material used dictates the effectiveness period of the wattle. Generally, Wattles are typically effective for one to two seasons.
- Prevent rilling beneath wattles by properly entrenching and abutting wattles together to prevent water from passing between them.

Design Criteria

- Install wattles perpendicular to the flow direction and parallel to the slope contour.
- Narrow trenches should be dug across the slope on contour to a depth of 3- to 5-inches on clay soils and soils with gradual slopes. On loose soils, steep slopes, and areas with high rainfall, the trenches should be dug to a depth of 5- to 7- inches, or 1/2 to 2/3 of the thickness of the wattle.
- Start building trenches and installing wattles from the base of the slope and work up. Spread excavated material evenly along the uphill slope and compacted using hand tamping or other methods.
- Construct trenches at intervals of 10- to 25-feet depending on the steepness of the slope, soil type, and rainfall. The steeper the slope the closer together the trenches.

- Install the wattles snugly into the trenches and abut tightly end to end. Do not overlap the ends.
- Install stakes at each end of the wattle, and at 4-foot centers along entire length of wattle.
- If required, install pilot holes for the stakes using a straight bar to drive holes through the wattle and into the soil.
- Wooden stakes should be approximately 3/4 x 3/4 x 24 inches min. Willow cuttings or 3/8-inch rebar can also be used for stakes.
- Stakes should be driven through the middle of the wattle, leaving 2 to 3 inches of the stake protruding above the wattle.

Maintenance Standards

- Wattles may require maintenance to ensure they are in contact with soil and thoroughly entrenched, especially after significant rainfall on steep sandy soils.

Figure II-4.2.14 Wattles



[2014 Figure II-4.2.14 pdf download](#)

- Inspect the slope after significant storms and repair any areas where wattles are not tightly abutted or water has scoured beneath the wattles.

Approved as Equivalent

Ecology has approved products as able to meet the requirements of [BMP C235: Wattles](#). The products did not pass through the Technology Assessment Protocol – Ecology (TAPE) process. Local jurisdictions may choose not to accept this product approved as equivalent, or may require additional testing prior to consideration for local use. The products are available for review on Ecology’s website at <http://www.ecy.wa.gov/programs/wq/stormwater/newtech/equivalent.html>

Washington State Department of Ecology

[2012 Stormwater Management Manual for Western Washington, as Amended in December 2014 \(The 2014 SWMMWW\)](#)

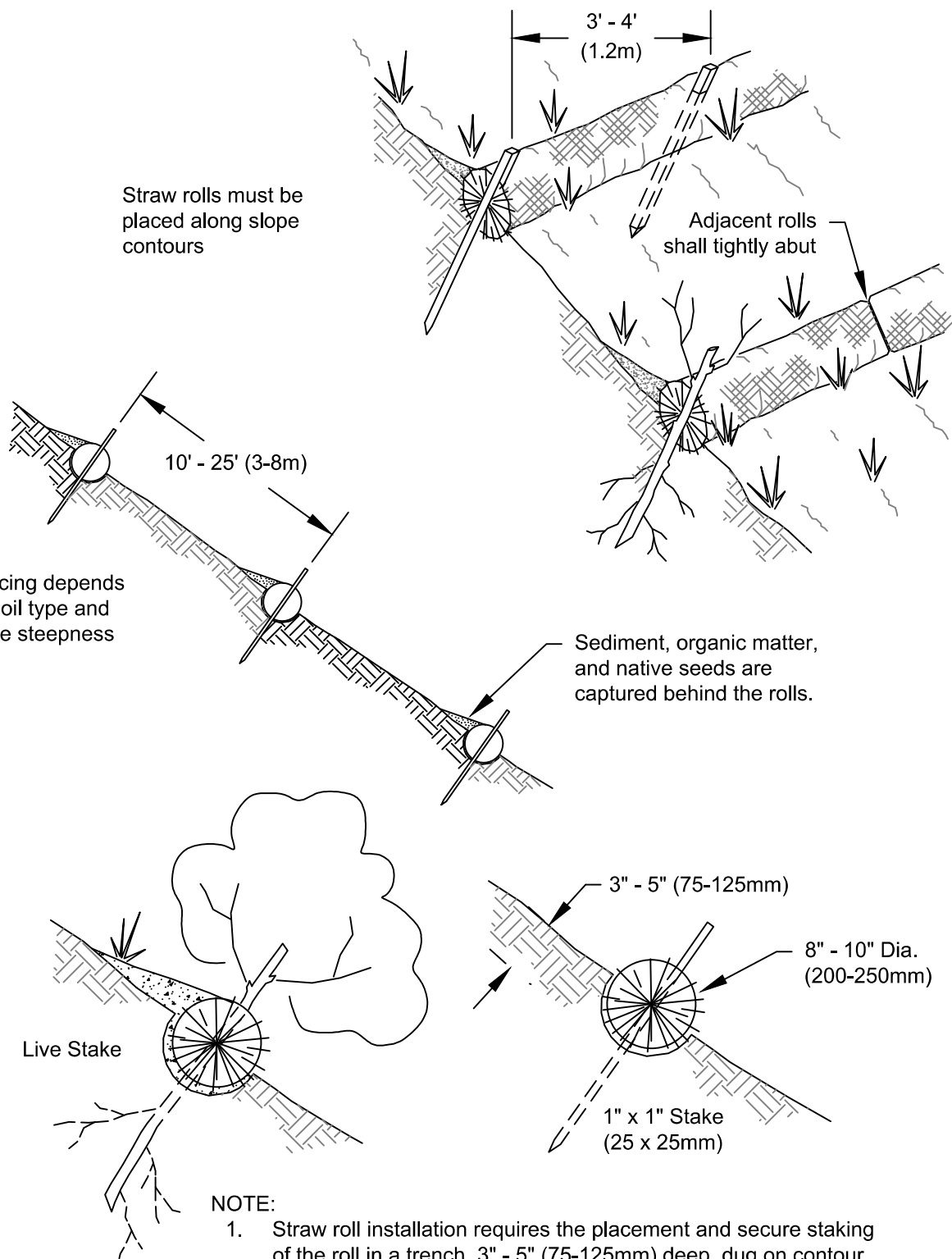

NOT TO SCALE



DEPARTMENT OF
ECOLOGY
State of Washington

Figure II-4.2.14 Wattles

Revised November 2015

Please see <http://www.ecy.wa.gov/copyright.html> for copyright notice including permissions, limitation of liability, and disclaimer.

BMP C236: Vegetative Filtration

Purpose

Vegetative filtration as a BMP is used in conjunction with detention storage in the form of portable tanks or [BMP C241: Sediment Pond \(Temporary\)](#), [BMP C206: Level Spreader](#), and a pumping system with surface intake. Vegetative filtration improves turbidity levels of stormwater discharges by filtering runoff through existing vegetation where undisturbed forest floor duff layer or established lawn with thatch layer are present. Vegetative filtration can also be used to infiltrate dewatering waste from foundations, vaults, and trenches as long as runoff does not occur.

Conditions of Use

- For every five acres of disturbed soil use one acre of grass field, farm pasture, or wooded area. Reduce or increase this area depending on project size, ground water table height, and other site conditions.
- Wetlands shall not be used for vegetative filtration.
- Do not use this BMP in areas with a high ground water table, or in areas that will have a high seasonal ground water table during the use of this BMP.
- This BMP may be less effective on soils that prevent the infiltration of the water, such as hard till.
- Using other effective source control measures throughout a construction site will prevent the generation of additional highly turbid water and may reduce the time period or area need for this BMP.
- Stop distributing water into the vegetated filtration area if standing water or erosion results.
- On large projects that phase the clearing of the site, areas retained with native vegetation may be used as a temporary vegetative filtration area.

Design Criteria

- Find land adjacent to the project site that has a vegetated field, preferably a farm field, or wooded area.
- If the site does not contain enough vegetated field area consider obtaining permission from adjacent landowners (especially for farm fields).
- Install a pump and downstream distribution manifold depending on the project size. Generally, the main distribution line should reach 100 to 200-feet long (large projects, or projects on tight soil, will require systems that reach several thousand feet long with numerous branch lines off of the main distribution line).
- The manifold should have several valves, allowing for control over the distribution area in the field.

- Install several branches of 4-inch diameter schedule 20 polyvinyl chloride (PVC), swaged-fit common septic tight-lined sewer line, or 6-inch diameter fire hose, which can convey the turbid water out to various sections of the field. See [Figure II-3.25: Manifold and Branches in a Wooded, Vegetated Spray Field](#).
- Determine the branch length based on the field area geography and number of branches. Typically, branches stretch from 200-feet to several thousand feet. Lay the branches on contour with the slope.
- On uneven ground, sprinklers perform well. Space sprinkler heads so that spray patterns do not overlap.
- On relatively even surfaces, a level spreader using 4-inch perforated pipe may be used as an alternative option to the sprinkler head setup. Install drain pipe at the highest point on the field and at various lower elevations to ensure full coverage of the filtration area. Place the pipe with the holes up to allow for gentle weeping evenly out all holes. Leveling the pipe by staking and using sandbags may be required.
- To prevent over saturating of the vegetative filtration area, rotate the use of branches or spray heads. Repeat as needed based on monitoring the spray field.

Table II-3.13: Flowpath Guidelines for Vegetative Filtration

Average Slope	Average Area % Slope	Estimated Flowpath Length (ft)
1.5H:1V	67%	250
2H:1V	50%	200
4H:1V	25%	150
6H:1V	16.7%	115
10H:1V	10%	100

Figure II-3.25: Manifold and Branches in a Wooded, Vegetated Spray Field



[pdf download](#)

Maintenance Standards

- Monitor the spray field on a daily basis to ensure that over saturation of any portion of the field doesn't occur at any time. The presence of standing puddles of water or creation of concentrated flows visually signify that over saturation of the field has occurred.

- Monitor the vegetated spray field all the way down to the nearest surface water, or farthest spray area, to ensure that the water has not caused overland or concentrated flows, and has not created erosion around the spray nozzle(s).
- Do not exceed water quality standards for turbidity.
- Ecology recommends that a separate inspection log be developed, maintained and kept with the existing site logbook to aid the operator conducting inspections. This separate “Field Filtration Logbook” can also aid in demonstrating compliance with permit conditions.
- Inspect the spray nozzles daily, at a minimum, for leaks and plugging from sediment particles.
- If erosion, concentrated flows, or over saturation of the field occurs, rotate the use of branches or spray heads or move the branches to a new field location.
- Check all branches and the manifold for unintended leaks.

Washington State Department of Ecology

2019 Stormwater Management Manual for Western Washington (2019 SWMMWW)

Publication No.19-10-021

BMP C240: Sediment Trap

Purpose

A sediment trap is a small temporary ponding area with a gravel outlet used to collect and store sediment from sites cleared and/or graded during construction. Sediment traps, along with other perimeter controls, shall be installed before any land disturbance takes place in the drainage area.

Conditions of Use

Prior to leaving a construction site, stormwater runoff must pass through a sediment pond or trap or other appropriate sediment removal best management practice. Non-engineered sediment traps may be used on-site prior to an engineered sediment trap or sediment pond to provide additional sediment removal capacity.

It is intended for use on sites where the tributary drainage area is less than 3 acres, with no unusual drainage features, and a projected build-out time of six months or less. The sediment trap is a temporary measure (with a design life of approximately 6 months) and shall be maintained until the site area is permanently protected against erosion by vegetation and/or structures.

Sediment traps and ponds are only effective in removing sediment down to about the medium silt size fraction. Runoff with sediment of finer grades (fine silt and clay) will pass through untreated, emphasizing the need to control erosion to the maximum extent first.

Whenever possible, sediment-laden water shall be discharged into onsite, relatively level, vegetated areas (see BMP C234 – Vegetated Strip). This is the only way to effectively remove fine particles from runoff unless chemical treatment or filtration is used. This can be particularly useful after initial treatment in a sediment trap or pond. The areas of release must be evaluated on a site-by-site basis in order to determine appropriate locations for and methods of releasing runoff. Vegetated wetlands shall not be used for this purpose. Frequently, it may be possible to pump water from the collection point at the downhill end of the site to an upslope vegetated area. Pumping shall only augment the treatment system, not replace it, because of the possibility of pump failure or runoff volume in excess of pump capacity.

All projects that are constructing permanent facilities for runoff quantity control should use the rough-graded or final-graded permanent facilities for traps and ponds. This includes combined facilities and infiltration facilities. When permanent facilities are used as temporary sedimentation facilities, the surface area requirement of a sediment trap or pond must be met. If the surface area requirements are larger than the surface area of the permanent facility, then the trap or pond shall be enlarged to comply with the surface area requirement. The permanent pond shall also be divided into two cells as required for sediment ponds.

Either a permanent control structure or the temporary control structure (described in BMP C241, Temporary Sediment Pond) can be used. If a permanent control structure is used, it may be advisable to partially restrict the lower orifice with gravel to increase residence time while still allowing dewatering of the pond. A shut-off valve may be added to the control structure to allow complete retention of stormwater in emergency situations. In this case, an emergency overflow weir must be added.

A skimmer may be used for the sediment trap outlet if approved by the Local Permitting Authority.

***Design and
Installation
Specifications***

- See Figures 4.22 and 4.23 for details.
- If permanent runoff control facilities are part of the project, they should be used for sediment retention.
- To determine the sediment trap geometry, first calculate the design surface area (SA) of the trap, measured at the invert of the weir. Use the following equation:

$$SA = FS(Q_2/V_s)$$

where

Q_2 = Design inflow based on the peak discharge from the developed 2-year runoff event from the contributing drainage area as computed in the hydrologic analysis. The 10-year peak flow shall be used if the project size, expected timing and duration of construction, or downstream conditions warrant a higher level of protection. If no hydrologic analysis is required, the Rational Method may be used.

V_s = The settling velocity of the soil particle of interest. The 0.02 mm (medium silt) particle with an assumed density of 2.65 g/cm³ has been selected as the particle of interest and has a settling velocity (V_s) of 0.00096 ft/sec.

FS = A safety factor of 2 to account for non-ideal settling.

Therefore, the equation for computing surface area becomes:

$$SA = 2 \times Q_2 / 0.00096 \text{ or}$$

2080 square feet per cfs of inflow

Note: Even if permanent facilities are used, they must still have a surface area that is at least as large as that derived from the above formula. If they do not, the pond must be enlarged.

- To aid in determining sediment depth, all sediment traps shall have a staff gauge with a prominent mark 1-foot above the bottom of the trap.

- Sediment traps may not be feasible on utility projects due to the limited work space or the short-term nature of the work. Portable tanks may be used in place of sediment traps for utility projects.

Maintenance Standards

- Sediment shall be removed from the trap when it reaches 1-foot in depth.
- Any damage to the pond embankments or slopes shall be repaired.

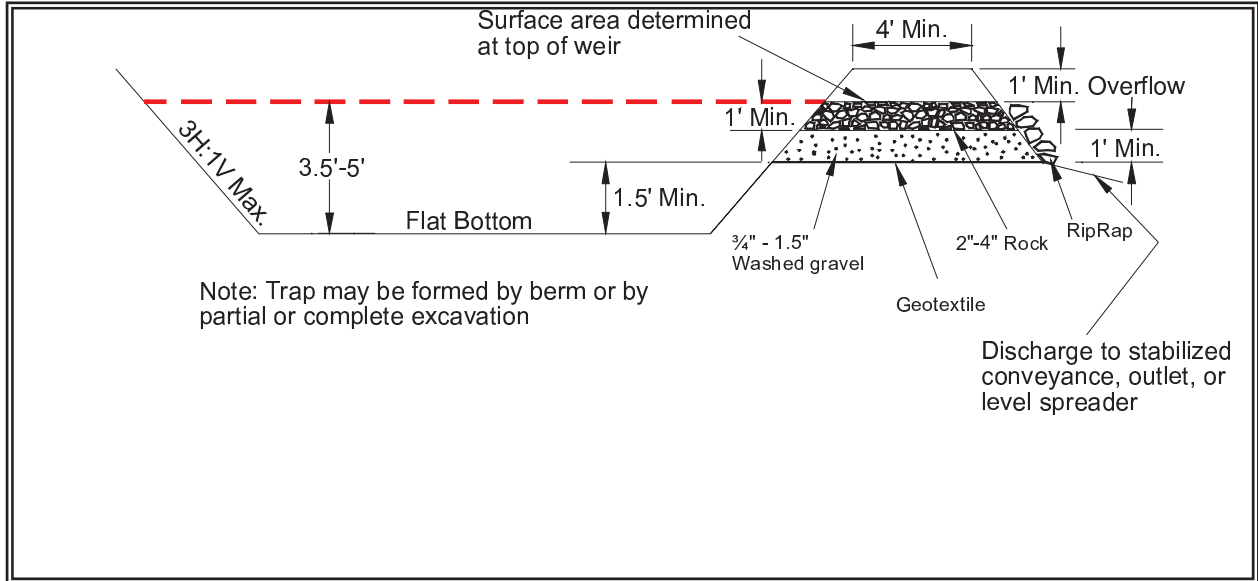

Figure 4.22 Cross Section of Sediment Trap

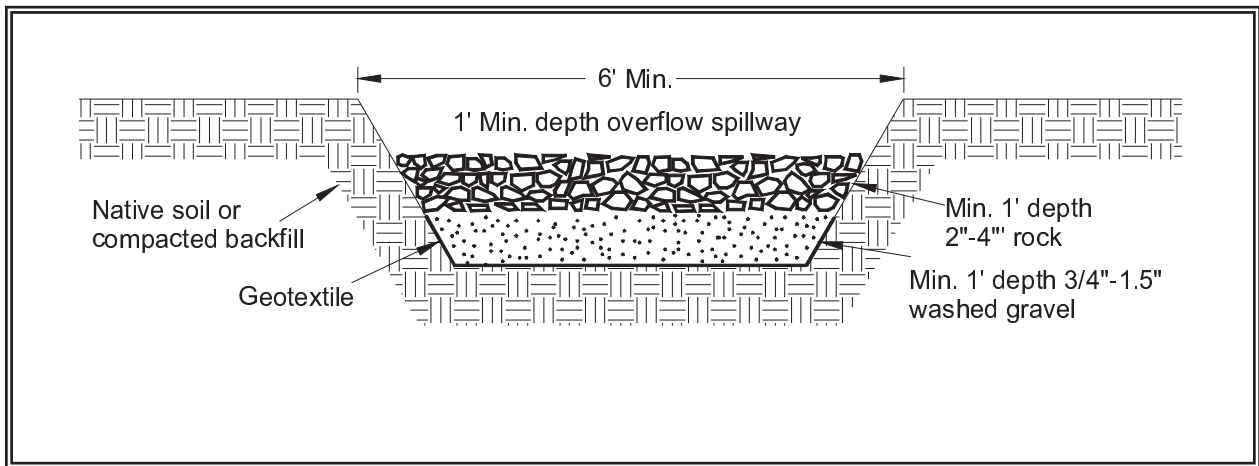

Figure 4.23 Sediment Trap Outlet

BMP C241: Temporary Sediment Pond

Purpose

Sediment ponds remove sediment from runoff originating from disturbed areas of the site. Sediment ponds are typically designed to remove sediment no smaller than medium silt (0.02 mm). Consequently, they usually reduce turbidity only slightly.

Conditions of Use

Prior to leaving a construction site, stormwater runoff must pass through a sediment pond or other appropriate sediment removal best management practice.

A sediment pond shall be used where the contributing drainage area is 3 acres or more. Ponds must be used in conjunction with erosion control practices to reduce the amount of sediment flowing into the basin.

Design and Installation Specifications

- Sediment basins must be installed only on sites where failure of the structure would not result in loss of life, damage to homes or buildings, or interruption of use or service of public roads or utilities. Also, sediment traps and ponds are attractive to children and can be very dangerous. Compliance with local ordinances regarding health and safety must be addressed. If fencing of the pond is required, the type of fence and its location shall be shown on the ESC plan.
- Structures having a maximum storage capacity at the top of the dam of 10 acre-ft (435,600 ft³) or more are subject to the Washington Dam Safety Regulations (Chapter 173-175 WAC).
- See Figure 4.24, Figure 4.25, and Figure 4.26 for details.
- If permanent runoff control facilities are part of the project, they should be used for sediment retention. The surface area requirements of the sediment basin must be met. This may require enlarging the permanent basin to comply with the surface area requirements. If a permanent control structure is used, it may be advisable to partially restrict the lower orifice with gravel to increase residence time while still allowing dewatering of the basin.
- Use of infiltration facilities for sedimentation basins during construction tends to clog the soils and reduce their capacity to infiltrate. If infiltration facilities are to be used, the sides and bottom of the facility must only be rough excavated to a minimum of 2 feet above final grade. Final grading of the infiltration facility shall occur only when all contributing drainage areas are fully stabilized. The infiltration pretreatment facility should be fully constructed and used with the sedimentation basin to help prevent clogging.
- Determining Pond Geometry
Obtain the discharge from the hydrologic calculations of the peak flow for the 2-year runoff event (Q_2). The 10-year peak flow shall be used if the project size, expected timing and duration of construction, or downstream conditions warrant a higher level of protection. If no hydrologic analysis is required, the Rational Method may be used.

Determine the required surface area at the top of the riser pipe with the equation:

$$SA = \frac{2 \times Q_2}{0.00096} \quad \text{or} \\ 2080 \text{ square feet per cfs of inflow}$$

See BMP C240 for more information on the derivation of the surface area calculation.

The basic geometry of the pond can now be determined using the following design criteria:

- Required surface area SA (from Step 2 above) at top of riser.
- Minimum 3.5-foot depth from top of riser to bottom of pond.
- Maximum 3:1 interior side slopes and maximum 2:1 exterior slopes. The interior slopes can be increased to a maximum of 2:1 if fencing is provided at or above the maximum water surface.
- One foot of freeboard between the top of the riser and the crest of the emergency spillway.
- Flat bottom.
- Minimum 1-foot deep spillway.
- Length-to-width ratio between 3:1 and 6:1.
- Sizing of Discharge Mechanisms.

The outlet for the basin consists of a combination of principal and emergency spillways. These outlets must pass the peak runoff expected from the contributing drainage area for a 100-year storm. If, due to site conditions and basin geometry, a separate emergency spillway is not feasible, the principal spillway must pass the entire peak runoff expected from the 100-year storm. However, an attempt to provide a separate emergency spillway should always be made. The runoff calculations should be based on the site conditions during construction. The flow through the dewatering orifice cannot be utilized when calculating the 100-year storm elevation because of its potential to become clogged; therefore, available spillway storage must begin at the principal spillway riser crest.

The principal spillway designed by the procedures contained in this standard will result in some reduction in the peak rate of runoff. However, the riser outlet design will not adequately control the basin discharge to the predevelopment discharge limitations as stated in Minimum Requirement #7: Flow Control. However, if the basin for a permanent stormwater detention pond is used for a temporary sedimentation basin, the control structure for the permanent pond can be used to maintain predevelopment discharge limitations. The size of the basin, the expected life of the construction project, the anticipated downstream effects and the anticipated weather conditions during construction, should be considered to determine the need of additional discharge control. See Figure 4.28 for riser inflow curves.

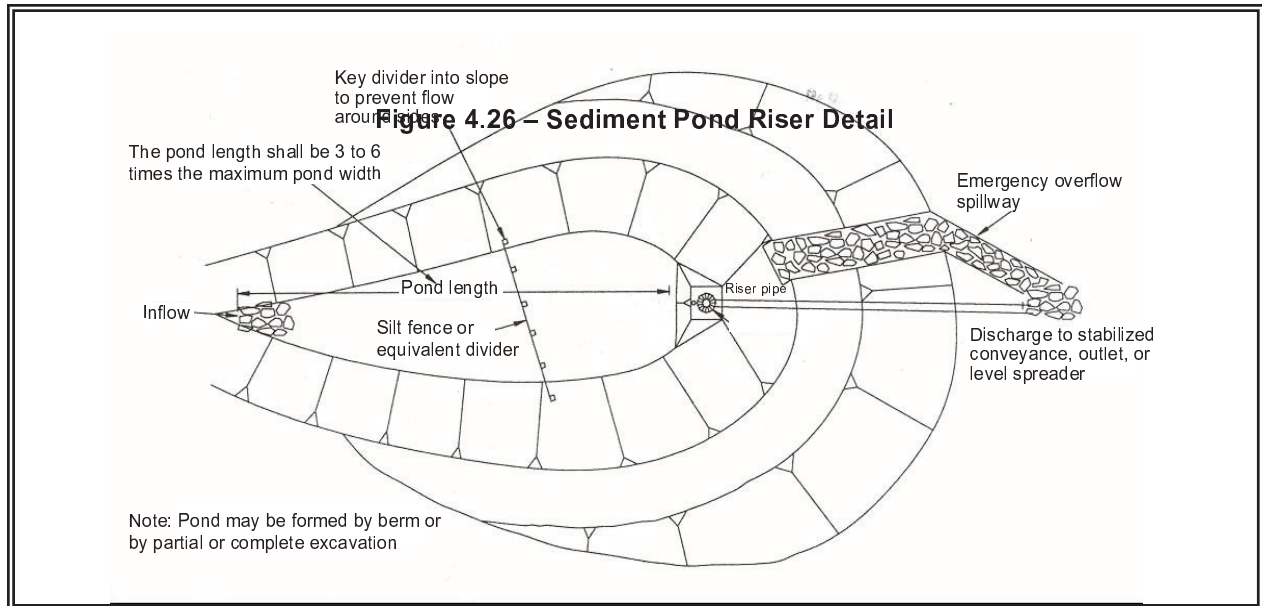

Figure 4.24 – Sediment Pond Plan View

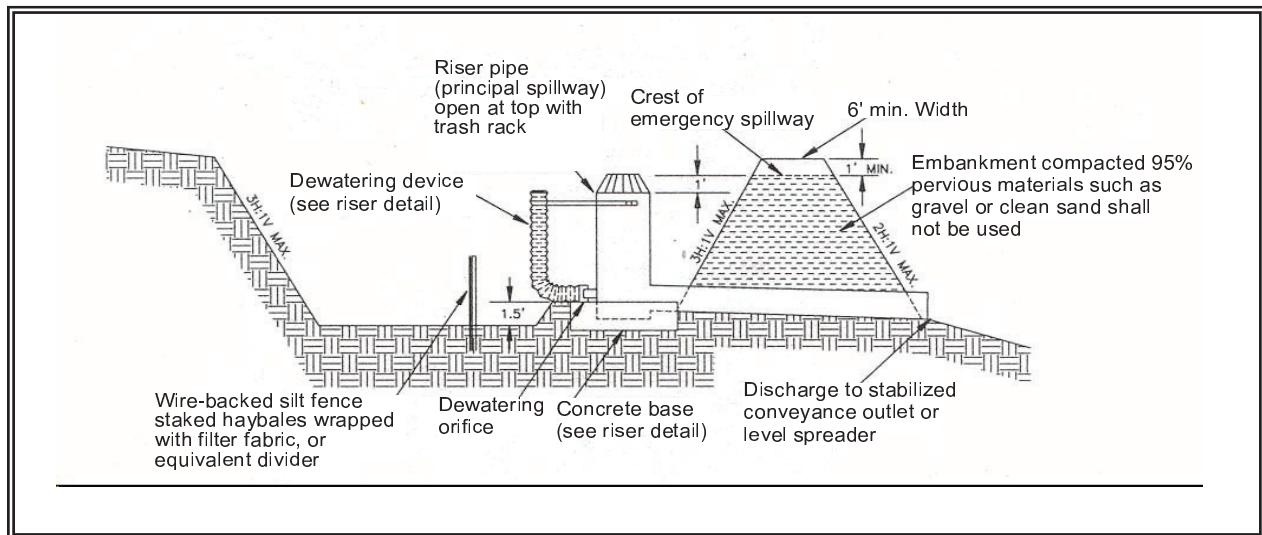

Figure 4.25 – Sediment Pond Cross Section

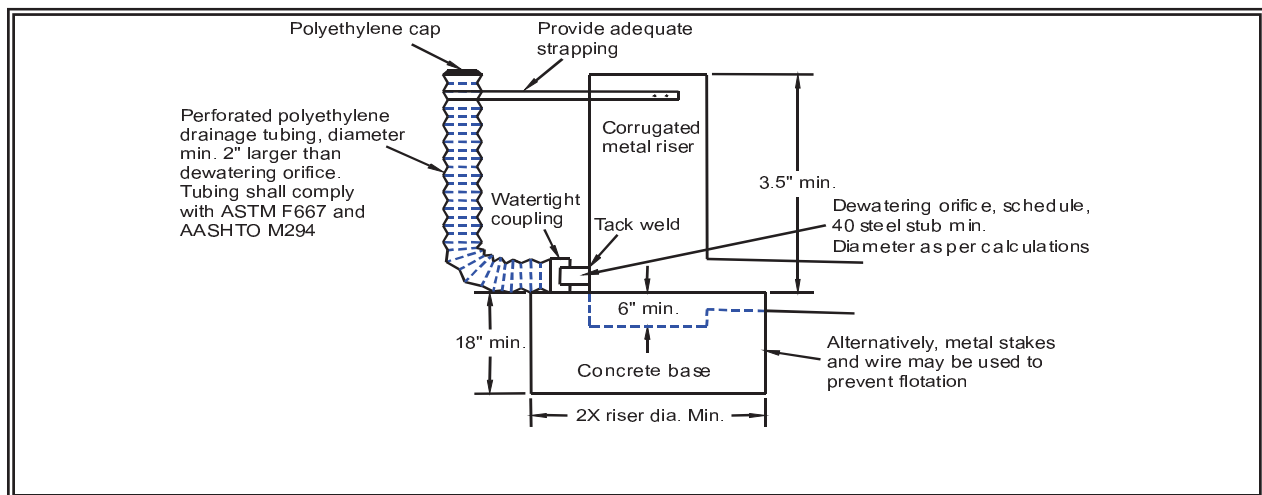

Figure 4.26 – Sediment Pond Riser Detail

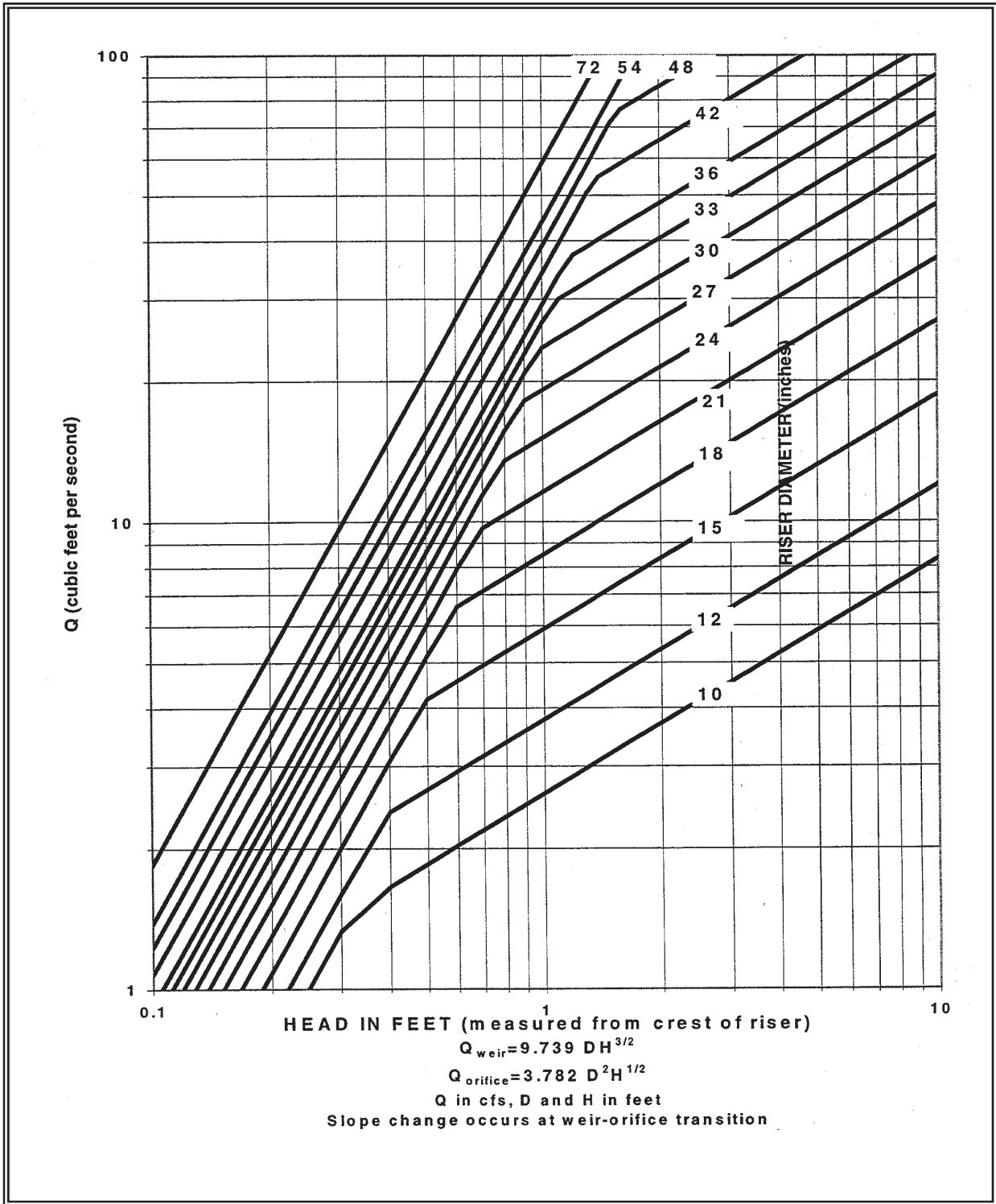

Figure 4.27 – Riser Inflow Curves

Principal Spillway: Determine the required diameter for the principal spillway (riser pipe). The diameter shall be the minimum necessary to pass the pre-developed 10-year peak flow (Q_{10}). Use Figure 4.28 to determine this diameter ($h = 1$ -foot). *Note: A permanent control structure may be used instead of a temporary riser.*

Emergency Overflow Spillway: Determine the required size and design of the emergency overflow spillway for the developed 100-year peak flow using the method contained in Volume III.

Dewatering Orifice: Determine the size of the dewatering orifice(s) (minimum 1-inch diameter) using a modified version of the discharge equation for a vertical orifice and a basic equation for the area of a circular orifice. Determine the required area of the orifice with the following equation:

$$A_o = \frac{A_s (2h)^{0.5}}{0.6 \times 3600 T g^{0.5}}$$

where A_o = orifice area (square feet)
 A_s = pond surface area (square feet)
 h = head of water above orifice (height of riser in feet)
 T = dewatering time (24 hours)
 g = acceleration of gravity (32.2 feet/second²)

Convert the required surface area to the required diameter D of the orifice:

$$D = 24 \times \sqrt{\frac{A_o}{\pi}} = 13.54 \times \sqrt{A_o}$$

The vertical, perforated tubing connected to the dewatering orifice must be at least 2 inches larger in diameter than the orifice to improve flow characteristics. The size and number of perforations in the tubing should be large enough so that the tubing does not restrict flow. The orifice should control the flow rate.

- **Additional Design Specifications**

The **pond shall be divided** into two roughly equal volume cells by a permeable divider that will reduce turbulence while allowing movement of water between cells. The divider shall be at least one-half the height of the riser and a minimum of one foot below the top of the riser. Wire-backed, 2- to 3-foot high, extra strength filter fabric supported by treated 4"x4"s can be used as a divider. Alternatively, staked straw bales wrapped with filter fabric (geotextile) may be used. If the pond is more than 6 feet deep, a different mechanism must be proposed. A riprap embankment is one acceptable method of separation for deeper ponds. Other designs that satisfy the intent of

this provision are allowed as long as the divider is permeable, structurally sound, and designed to prevent erosion under or around the barrier.

To aid in determining sediment depth, **one-foot intervals** shall be prominently marked on the riser.

If an **embankment** of more than 6 feet is proposed, the pond must comply with the criteria contained in Volume III regarding dam safety for detention BMPs.

- The most common structural failure of sedimentation basins is caused by piping. Piping refers to two phenomena: (1) water seeping through fine-grained soil, eroding the soil grain by grain and forming pipes or tunnels; and, (2) water under pressure flowing upward through a granular soil with a head of sufficient magnitude to cause soil grains to lose contact and capability for support.

The most critical construction sequences to prevent piping will be:

1. Tight connections between riser and barrel and other pipe connections.
2. Adequate anchoring of riser.
3. Proper soil compaction of the embankment and riser footing.
4. Proper construction of anti-seep devices.

Maintenance Standards

- Sediment shall be removed from the pond when it reaches 1-foot in depth.
- Any damage to the pond embankments or slopes shall be repaired.

BMP C251: Construction Stormwater Filtration

Purpose

Filtration removes sediment from runoff originating from disturbed areas of the site.

Background Information:

Filtration with sand media has been used for over a century to treat water and wastewater. The use of sand filtration for treatment of stormwater has developed recently, generally to treat runoff from streets, parking lots, and residential areas. The application of filtration to construction stormwater treatment is currently under development.

Conditions of Use

Traditional BMPs used to control soil erosion and sediment loss from sites under development may not be adequate to ensure compliance with the water quality standard for turbidity in the receiving water. Filtration may be used in conjunction with gravity settling to remove sediment as small as fine silt (0.5 μm). The reduction in turbidity will be dependent on the particle size distribution of the sediment in the stormwater. In some circumstances, sedimentation and filtration may achieve compliance with the water quality standard for turbidity.

The use of construction stormwater filtration does not require approval from Ecology as long as treatment chemicals are not used. Filtration in conjunction with polymer treatment requires testing under the Chemical Technology Assessment Protocol – Ecology (CTAPE) before it can be initiated. Approval from the appropriate regional Ecology office must be obtained at each site where polymers use is proposed prior to use. For more guidance on stormwater chemical treatment see [BMP C250: Construction Stormwater Chemical Treatment](#).

Design and Installation Specifications

Two types of filtration systems may be applied to construction stormwater treatment: rapid and slow. Rapid sand filters are the typical system used for water and wastewater treatment. They can achieve relatively high hydraulic flow rates, on the order of 2 to 20 gpm/sf, because they have automatic backwash systems to remove accumulated solids. In contrast, slow sand filters have very low hydraulic rates, on the order of 0.02 gpm/sf, because they do not have backwash systems. Slow sand filtration has generally been used to treat stormwater. Slow sand filtration is mechanically simple in comparison to rapid sand filtration but requires a much larger filter area.

Filtration Equipment. Sand media filters are available with automatic backwashing features that can filter to 50 μm particle size. Screen or bag filters can filter down to 5 μm . Fiber wound filters can remove

particles down to 0.5 µm. Filters should be sequenced from the largest to the smallest pore opening. Sediment removal efficiency will be related to particle size distribution in the stormwater.

Treatment Process Description. Stormwater is collected at interception point(s) on the site and is diverted to an untreated stormwater sediment pond or tank for removal of large sediment and storage of the stormwater before it is treated by the filtration system. The untreated stormwater is pumped from the trap, pond, or tank through the filtration system in a rapid sand filtration system. Slow sand filtration systems are designed as flow through systems using gravity.

Maintenance Standards

Rapid sand filters typically have automatic backwash systems that are triggered by a pre-set pressure drop across the filter. If the backwash water volume is not large or substantially more turbid than the untreated stormwater stored in the holding pond or tank, backwash return to the untreated stormwater pond or tank may be appropriate. However, other means of treatment and disposal may be necessary.

- Screen, bag, and fiber filters must be cleaned and/or replaced when they become clogged.
- Sediment shall be removed from the storage and/or treatment ponds as necessary. Typically, sediment removal is required once or twice during a wet season and at the decommissioning of the ponds.

Sizing Criteria for Flow-Through Treatment Systems for Flow Control Exempt Water Bodies:

When sizing storage ponds or tanks for flow-through systems for flow control exempt water bodies the treatment system capacity should be a factor. The untreated stormwater storage pond or tank should be sized to hold 1.5 times the runoff volume of the 10-year, 24-hour storm event minus the treatment system flowrate for an 8-hour period. For a chitosan-enhanced sand filtration system, the treatment system flowrate should be sized using a hydraulic loading rate between 6-8 gpm/ft². Other hydraulic loading rates may be more appropriate for other systems. Bypass should be provided around the chemical treatment system to accommodate extreme storms. Runoff volume shall be calculated using the methods presented in [Chapter III-2 - Hydrologic Analysis](#). Worst-case conditions (i.e., producing the most runoff) should be used for analyses (most likely conditions present prior to final landscaping).

Sizing Criteria for Flow Control Water Bodies:

Sites that must implement flow control for the developed site condition must also control stormwater release rates during construction. Construction site stormwater discharges shall not exceed the discharge durations of the pre-developed condition for the range of pre-developed discharge rates from 1/2 of the 2-year flow through the 10-year flow as predicted by an approved continuous runoff model.

The pre-developed condition to be matched shall be the land cover condition immediately prior to the development project. This restriction on release rates can affect the size of the storage pond, the filtration system, and the flow rate through the filter system.

The following is how WWHM can be used to determine the release rates from the filtration systems:

1. Determine the pre-developed flow durations to be matched by entering the land use area under the “Pre-developed” scenario in WWHM. The default flow range is from $\frac{1}{2}$ of the 2-year flow through the 10-year flow.
2. Enter the post developed land use area in the “Developed Unmitigated” scenario in WWHM.
3. Copy the land use information from the “Developed Unmitigated” to “Developed Mitigated” scenario.
4. There are two possible ways to model stormwater filtration systems:
 - a. The stormwater filtration system uses an untreated stormwater storage pond/tank and the discharge from this pond/tank is pumped to one or more filters. In-line filtration chemicals would be added to the flow right after the pond/tank and before the filter(s). Because the discharge is pumped, WWHM can’t generate a stage/storage /discharge (SSD) table for this system. This system is modeled the same way as described in [BMP C250: Construction Stormwater Chemical Treatment](#) and is as follows:

While in the “Developed Mitigated” scenario, add a pond element under the basin element containing the post-developed land use areas. This pond element represents information on the available untreated stormwater storage and discharge from the filtration system. In cases where the discharge from the filtration system is controlled by a pump, a stage/storage/discharge (SSD) table representing the pond must be generated outside WWHM and imported into WWHM. WWHM can route the runoff from the post-developed condition through this SSD table (the pond) and determine compliance with the flow duration standard. This would be an iterative design procedure where if the initial SSD table proved to be out of compliance, the designer would have to modify the SSD table outside WWHM and re-import in WWHM and route the runoff through it again. The iteration will continue until a pond that enables compliance with the flow duration standard is designed.

Notes on SSD table characteristics:

- The pump discharge rate would likely be initially set at just below $\frac{1}{2}$ if the 2-year flow from the pre-developed condition. As runoff coming into the untreated stormwater storage pond increases and the available untreated stormwater storage volume gets used up, it would be necessary to increase the pump discharge rate above $\frac{1}{2}$ of the 2-year. The increase(s) above $\frac{1}{2}$ of the 2-year must be such that they provide some relief to the untreated stormwater storage needs but at the same time they will not cause violations of the flow duration standard at the higher flows. The final design SSD table will identify the appropriate pumping rates and the corresponding stage and storages.
 - When building such a flow control system, the design must ensure that any automatic adjustments to the pumping rates will be as a result of changes to the available storage in accordance with the final design SSD table.
- b. The stormwater filtration system uses a storage pond/tank and the discharge from this pond/tank gravity flows to the filter. This is usually a slow sand filter system and it is possible to model it in WWHM as a Filter element or as a combination of Pond and Filter element placed in series. The stage/storage/discharge table(s) may then be generated within WWHM as follows:
- i. While in the “Developed Mitigated” scenario, add a Filter element under the basin element containing the post-developed land use areas. The length and width of this filter element would have to be the same as the bottom length and width of the upstream untreated stormwater storage pond/tank.
 - ii. In cases where the length and width of the filter is not the same as those for the bottom of the upstream untreated stormwater storage tank/pond, the treatment system may be modeled as a Pond element followed by a Filter element. By having these two elements, WWHM would then generate a SSD table for the storage pond which then gravity flows to the Filter element. The Filter element downstream of the untreated stormwater storage pond would have a storage component through the media, and an overflow component for when the filtration capacity is exceeded.

WWHM can route the runoff from the post-developed condition through the treatment systems in 4b and determine compliance with the flow duration standard. This would be an iterative design procedure where if the initial sizing estimates for the treatment system proved to be inadequate, the designer would

have to modify the system and route the runoff through it again. The iteration would continue until compliance with the flow duration standard is achieved.

5. It should be noted that the above procedures would be used to meet the flow control requirements. The filtration system must be able to meet the runoff treatment requirements. It is likely that the discharge flow rate of $\frac{1}{2}$ of the 2-year or more may exceed the treatment capacity of the system. If that is the case, the untreated stormwater discharge rate(s) (i.e., influent to the treatment system) must be reduced to allow proper treatment. Any reduction in the flows would likely result in the need for a larger untreated stormwater storage volume.

If system design does not allow you to discharge at the slower rates as described above and if the site has a retention or detention pond that will serve the planned development, the discharge from the treatment system may be directed to the permanent retention/detention pond to comply with the flow control requirements. In this case, the untreated stormwater storage pond and treatment system will be sized according to the sizing criteria for flow-through treatment systems for flow control exempt waterbodies described earlier except all discharges (water passing through the treatment system and stormwater bypassing the treatment system) will be directed into the permanent retention/detention pond. If site constraints make locating the untreated stormwater storage pond difficult, the permanent retention/detention pond may be divided to serve as the untreated stormwater discharge pond and the post-treatment flow control pond. A berm or barrier must be used in this case so the untreated water does not mix with the treated water. Both untreated stormwater storage requirements, and adequate post-treatment flow control must be achieved. The post-treatment flow control pond's revised dimensions must be entered into the WWHM and the WWHM must be run to confirm compliance with the flow control requirement.

Washington State Department of Ecology

[2012 Stormwater Management Manual for Western Washington, as Amended in December 2014. \(The 2014 SWMMWW\)](#)

Appendix D

Western Washington Hydrology Model 2012 Reports

WWHM2012

PROJECT REPORT

SOUTH BUSINESS & TECHNOLOGY CENTER PARKING EXPANSION PROJECT

In the Mitigated scenario, the Wetland Basin is tributary to the storm collection system. Per Ecology, if the Wetland Basin 100yr peak flow is greater than 50% of the project's post-development undetained flow (WWHM 701), then the runoff MUST bypass the storm facility. If less than 50% and the runoff is not bypassed, then the storm facility must be sized to account for the additional offsite inflow/runon. If not bypassed, include the groundwater component that was used for the wetland analysis in the modeling of the detention facility. [Storm Report; Pg 245 of 347]

Provide the 100yr peak flow comparison between the Wetland Basin and the post-development undetained flow (WWHM 701). [Storm Report; Pg 245 of 347]

General Model Information

Project Name: SHBTC Parking
Site Name:
Site Address:
City: Puyallup
Report Date: 2/11/2022
Gage:
Data Start: 10/01/1901
Data End: 09/30/2059
Timestep: 15 Minute
Precip Scale: 0.000 (adjusted)
Version Date: 2018/10/10
Version: 4.2.16

Provide Gage Information [Storm Report; Pg 246 of 347]

Clarify-why is the precipitation scale adjusted? This is a default setting in WWHM. [Storm Report; Pg 246 of 347]

POC Thresholds

Low Flow Threshold for POC1: 50 Percent of the 2 Year
High Flow Threshold for POC1: 50 Year

Landuse Basin Data

Predeveloped Land Use

SHBTC DB - EG

Bypass:	No
GroundWater:	No
Pervious Land Use	acre
C, Forest, Mod	4.78
C, Forest, Steep	5
SAT, Forest, Flat	0.1
Pervious Total	9.88
Impervious Land Use	acre
Impervious Total	0
Basin Total	9.88

Element Flows To:
Surface Interflow Groundwater

In the Mitigated scenario, the Wetland Basin is tributary to the storm collection system. Per Ecology, if the Wetland Basin 100yr peak flow is greater than 50% of the project's post-development undetained flow (WWHM 701), then the runoff MUST bypass the storm facility. If less than 50% and the runoff is not bypassed, then the storm facility must be sized to account for the additional offsite inflow/runon. If not bypassed, include the groundwater component that was used for the wetland analysis in the modeling of the detention facility.[Storm Report; Pg 247 of 347]

Mitigated Land Use

Upper Parking -FG

Bypass: No

GroundWater: No

Pervious Land Use acre

C, Forest, Mod 0.89

C, Lawn, Mod 0.16

Pervious Total 1.05

Impervious Land Use acre

ROADS MOD 1.87

0.13-ACRES OF INFILTRATION PLANTER

Impervious Total ~~1.87~~

PRECIPITATION IS APPLIED TO THE BIORETENTION NODE

2.00 - ACRES

Basin Total ~~2.92~~

3.05 - ACRES

Element Flows To:

Surface Interflow

Groundwater

Surface TION PLANTER

Lower Parking DB FG

Bypass: No

GroundWater: No

Pervious Land Use	acre
C, Lawn, Flat	0.6
C, Lawn, Steep	0.41
C, Forest, Mod	0.7
SAT, Forest, Flat	0.1
C, Forest, Steep	0.52

Pervious Total 2.33

Impervious Land Use	acre
ROADS FLAT	0.63
ROADS MOD	3.8

0.07-ACRES OF BIORETENTION SWALE

PRECIPITATION IS APPLIED TO THE BIORETENTION NODE

Impervious Total ~~4.43~~
4.50 - ACRES

Basin Total ~~6.76~~
6.83 - ACRES

Element Flows To:
Surface
Surface Bio-swale

Interflow

Groundwater

Routing Elements
Predeveloped Routing

Mitigated Routing

INFILTRATION PLANTER

Bottom Length: 550.00 ft.
 Bottom Width: 10.00 ft.
 Material thickness of first layer: 1.5
 Material type for first layer: SMMWW 12 in/hr
 Material thickness of second layer: 0.5
 Material type for second layer: GRAVEL
 Material thickness of third layer: 0
 Material type for third layer: GRAVEL
 Infiltration On
 Infiltration rate: 2.9
 Infiltration safety factor: 1
 Total Volume Infiltrated (ac-ft.): 793.423
 Total Volume Through Riser (ac-ft.): 0.038
 Total Volume Through Facility (ac-ft.): 793.461
 Percent Infiltrated: 100
 Total Precip Applied to Facility: 55.856
 Total Evap From Facility: 30.615
 Underdrain not used
 Discharge Structure
 Riser Height: 1 ft.
 Riser Diameter: 8 in.
 Element Flows To:
 Outlet 1 Outlet 2

TOTAL PLANTER LENGTH

Confirm-shouldn't mulch layer be included in the WWHM model. [Storm Report; Pg 251 of 347]

Bioretention Hydraulic Table

Stage(feet)	Area(ac.)	Volume(ac-ft.)	Discharge(cfs)	Infilt(cfs)
500.00	0.1263	0.0000	0.0000	0.0000
500.04	0.1263	0.0022	0.0000	0.0000
500.08	0.1263	0.0044	0.0000	0.0000
500.12	0.1263	0.0067	0.0000	0.0000
500.15	0.1263	0.0089	0.0012	0.0012
500.19	0.1263	0.0111	0.0030	0.0030
500.23	0.1263	0.0133	0.0058	0.0058
500.27	0.1263	0.0155	0.0098	0.0098
500.31	0.1263	0.0178	0.0151	0.0151
500.35	0.1263	0.0200	0.0219	0.0219
500.38	0.1263	0.0222	0.0303	0.0303
500.42	0.1263	0.0244	0.0404	0.0404
500.46	0.1263	0.0266	0.0523	0.0523
500.50	0.1263	0.0289	0.0661	0.0661
500.54	0.1263	0.0311	0.0819	0.0819
500.58	0.1263	0.0333	0.0998	0.0998
500.62	0.1263	0.0355	0.1198	0.1198
500.65	0.1263	0.0378	0.1421	0.1421
500.69	0.1263	0.0400	0.1668	0.1668
500.73	0.1263	0.0422	0.1938	0.1938
500.77	0.1263	0.0444	0.2234	0.2234
500.81	0.1263	0.0466	0.2554	0.2554
500.85	0.1263	0.0489	0.2901	0.2901
500.88	0.1263	0.0511	0.3275	0.3275
500.92	0.1263	0.0533	0.3677	0.3677
500.96	0.1263	0.0555	0.3692	0.3692

501.00	0.1263	0.0577	0.3692	0.3692
501.04	0.1263	0.0600	0.3692	0.3692
501.08	0.1263	0.0622	0.3692	0.3692
501.12	0.1263	0.0644	0.3692	0.3692
501.15	0.1263	0.0666	0.3692	0.3692
501.19	0.1263	0.0688	0.3692	0.3692
501.23	0.1263	0.0711	0.3692	0.3692
501.27	0.1263	0.0733	0.3692	0.3692
501.31	0.1263	0.0755	0.3692	0.3692
501.35	0.1263	0.0777	0.3692	0.3692
501.38	0.1263	0.0799	0.3692	0.3692
501.42	0.1263	0.0822	0.3692	0.3692
501.46	0.1263	0.0844	0.3692	0.3692
501.50	0.1263	0.0864	0.3692	0.3692
501.54	0.1263	0.0884	0.3692	0.3692
501.58	0.1263	0.0904	0.3692	0.3692
501.62	0.1263	0.0925	0.3692	0.3692
501.65	0.1263	0.0945	0.3692	0.3692
501.69	0.1263	0.0965	0.3692	0.3692
501.73	0.1263	0.0985	0.3692	0.3692
501.77	0.1263	0.1005	0.3692	0.3692
501.81	0.1263	0.1025	0.3692	0.3692
501.85	0.1263	0.1045	0.3692	0.3692
501.88	0.1263	0.1066	0.3692	0.3692
501.92	0.1263	0.1086	0.3692	0.3692
501.96	0.1263	0.1106	0.3692	0.3692
502.00	0.1263	0.1126	0.3692	0.3692

Bioretention Hydraulic Table

Stage(feet)	Area(ac.)	Volume(ac-ft.)	Discharge(cfs)	To Amended(cfs)	Infiltr(cfs)
2.0000	0.1263	0.1126	0.0000	1.5278	0.0000
2.0385	0.1263	0.1175	0.0000	1.5278	0.0000
2.0769	0.1263	0.1223	0.0000	1.6061	0.0000
2.1154	0.1263	0.1272	0.0000	1.6453	0.0000
2.1538	0.1263	0.1320	0.0000	1.6845	0.0000
2.1923	0.1263	0.1369	0.0000	1.7236	0.0000
2.2308	0.1263	0.1417	0.0000	1.7628	0.0000
2.2692	0.1263	0.1466	0.0000	1.8020	0.0000
2.3077	0.1263	0.1515	0.0000	1.8412	0.0000
2.3462	0.1263	0.1563	0.0000	1.8803	0.0000
2.3846	0.1263	0.1612	0.0000	1.9195	0.0000
2.4231	0.1263	0.1660	0.0000	1.9587	0.0000
2.4615	0.1263	0.1709	0.0000	1.9979	0.0000
2.5000	0.1263	0.1757	0.0000	2.0370	0.0000
2.5385	0.1263	0.1806	0.0000	2.0762	0.0000
2.5769	0.1263	0.1854	0.0000	2.1154	0.0000
2.6154	0.1263	0.1903	0.0000	2.1546	0.0000
2.6538	0.1263	0.1952	0.0000	2.1937	0.0000
2.6923	0.1263	0.2000	0.0000	2.2329	0.0000
2.7308	0.1263	0.2049	0.0000	2.2721	0.0000
2.7692	0.1263	0.2097	0.0000	2.3113	0.0000
2.8077	0.1263	0.2146	0.0000	2.3504	0.0000
2.8462	0.1263	0.2194	0.0000	2.3896	0.0000
2.8846	0.1263	0.2243	0.0000	2.4288	0.0000
2.9231	0.1263	0.2292	0.0000	2.4680	0.0000
2.9615	0.1263	0.2340	0.0000	2.5071	0.0000
3.0000	0.1263	0.2389	0.0000	2.5463	0.0000
3.0385	0.1263	0.2437	0.0000	2.5855	0.0000

3.0769	0.1263	0.2486	0.0000	2.6246	0.0000
3.1154	0.1263	0.2534	0.0000	2.6638	0.0000
3.1538	0.1263	0.2583	0.0000	2.7030	0.0000
3.1923	0.1263	0.2631	0.0000	2.7422	0.0000
3.2308	0.1263	0.2680	0.0000	2.7813	0.0000
3.2692	0.1263	0.2729	0.0000	2.8205	0.0000
3.3077	0.1263	0.2777	0.0000	2.8597	0.0000
3.3462	0.1263	0.2826	0.0000	2.8989	0.0000
3.3846	0.1263	0.2874	0.0000	2.9380	0.0000
3.4231	0.1263	0.2923	0.0000	2.9772	0.0000
3.4615	0.1263	0.2971	0.0000	3.0164	0.0000
3.5000	0.1263	0.3020	0.0000	3.0556	0.0000
3.5000	0.1263	0.3020	0.0000	3.0556	0.0000

Surface TION PLANTER

Element Flows To:

Outlet 1

Outlet 2

INFILTRATION PLANTER

Bio-swale

Bottom Length: 190.00 ft.
 Bottom Width: 18.00 ft.
 Material thickness of first layer: 1.5
 Material type for first layer: SMMWW 12 in/hr
 Material thickness of second layer: 1
 Material type for second layer: GRAVEL
 Material thickness of third layer: 0
 Material type for third layer: GRAVEL
 Underdrain used
 Underdrain Diameter (feet): 0.5
 Orifice Diameter (in.): 5.9
 Offset (in.): 0.25
 Flow Through Underdrain (ac-ft.): 1840.713
 Total Outflow (ac-ft.): 1841.607
 Percent Through Underdrain: 99.95
 Discharge Structure
 Riser Height: 1 ft.
 Riser Diameter: 12 in.
 Element Flows To:
 Outlet 1 Outlet 2
 StormTech 2

Verify-Section 2/TS-01 indicates 18 inches of gravel. [Storm Report; Pg 255 of 347]

MODELLED AS SINGLE BIORETENTION SWALE

THERE WILL BE SIX (6) SEPARATE BIORETENTION SWALES 190' X 3' WITH UNDERDRAINS FOR WQ TREATMENT IN DRIVE AISLES THROUGHOUT THE BASIN

What about the entrance road grassy swale? See comments Sheet SD-03. [Storm Report; Pg 255 of 347]

Confirm-0.5 offset per 2/TS-01 [Storm Report; Pg 255 of 347]

Bioretention Hydraulic Table

Stage(feet)	Area(ac.)	Volume(ac-ft.)	Discharge(cfs)	Infilt(cfs)
0.0000	0.1553	0.0000	0.0000	0.0000
0.0440	0.1540	0.0008	0.0000	0.0000
0.0879	0.1526	0.0016	0.0000	0.0000
0.1319	0.1512	0.0024	0.0003	0.0000
0.1758	0.1497	0.0033	0.0010	0.0000
0.2198	0.1483	0.0041	0.0025	0.0000
0.2637	0.1469	0.0050	0.0049	0.0000
0.3077	0.1455	0.0058	0.0083	0.0000
0.3516	0.1441	0.0067	0.0130	0.0000
0.3956	0.1426	0.0076	0.0188	0.0000
0.4396	0.1412	0.0085	0.0261	0.0000
0.4835	0.1398	0.0095	0.0348	0.0000
0.5275	0.1384	0.0104	0.0451	0.0000
0.5714	0.1370	0.0113	0.0571	0.0000
0.6154	0.1356	0.0123	0.0708	0.0000
0.6593	0.1342	0.0133	0.0863	0.0000
0.7033	0.1328	0.0143	0.1037	0.0000
0.7473	0.1314	0.0153	0.1106	0.0000
0.7912	0.1301	0.0163	0.1444	0.0000
0.8352	0.1287	0.0173	0.1559	0.0000
0.8791	0.1273	0.0184	0.1804	0.0000
0.9231	0.1259	0.0194	0.1820	0.0000
0.9670	0.1245	0.0205	0.2318	0.0000
1.0110	0.1232	0.0216	0.2514	0.0000
1.0549	0.1218	0.0227	0.2674	0.0000
1.0989	0.1204	0.0238	0.2725	0.0000
1.1429	0.1191	0.0249	0.3076	0.0000
1.1868	0.1177	0.0260	0.3389	0.0000
1.2308	0.1164	0.0272	0.3676	0.0000
1.2747	0.1150	0.0283	0.3940	0.0000
1.3187	0.1137	0.0295	0.4166	0.0000

1.3626	0.1123	0.0307	0.4188	0.0000
1.4066	0.1110	0.0319	0.4421	0.0000
1.4505	0.1097	0.0331	0.4643	0.0000
1.4945	0.1083	0.0344	0.4854	0.0000
1.5385	0.1070	0.0355	0.5056	0.0000
1.5824	0.1057	0.0366	0.5250	0.0000
1.6264	0.1043	0.0378	0.5437	0.0000
1.6703	0.1030	0.0389	0.5618	0.0000
1.7143	0.1017	0.0401	0.5793	0.0000
1.7582	0.1004	0.0413	0.5962	0.0000
1.8022	0.0991	0.0425	0.6128	0.0000
1.8462	0.0978	0.0437	0.6288	0.0000
1.8901	0.0965	0.0450	0.6445	0.0000
1.9341	0.0952	0.0462	0.6598	0.0000
1.9780	0.0939	0.0475	0.6747	0.0000
2.0220	0.0926	0.0487	0.6893	0.0000
2.0659	0.0913	0.0500	0.7037	0.0000
2.1099	0.0900	0.0513	0.7177	0.0000
2.1538	0.0887	0.0526	0.7416	0.0000
2.1978	0.0874	0.0539	0.7681	0.0000
2.2418	0.0861	0.0553	0.7937	0.0000
2.2857	0.0848	0.0566	0.8186	0.0000
2.3297	0.0836	0.0580	0.8428	0.0000
2.3736	0.0823	0.0594	0.8665	0.0000
2.4176	0.0810	0.0607	0.8898	0.0000
2.4615	0.0798	0.0621	0.9135	0.0000
2.5000	0.0785	0.0634	0.9439	0.0000

Bioretention Hydraulic Table

Stage(feet)	Area(ac.)	Volume(ac-ft.)	Discharge(cfs)	To Amended(cfs)	Infiltr(cfs)
2.5000	0.1553	0.0634	0.0000	0.9500	0.0000
2.5440	0.1567	0.0702	0.0000	0.9500	0.0000
2.5879	0.1582	0.0772	0.0000	1.0057	0.0000
2.6319	0.1596	0.0841	0.0000	1.0335	0.0000
2.6758	0.1611	0.0912	0.0000	1.0614	0.0000
2.7198	0.1625	0.0983	0.0000	1.0892	0.0000
2.7637	0.1640	0.1055	0.0000	1.1170	0.0000
2.8077	0.1655	0.1127	0.0000	1.1449	0.0000
2.8516	0.1669	0.1200	0.0000	1.1727	0.0000
2.8956	0.1684	0.1274	0.0000	1.2006	0.0000
2.9396	0.1699	0.1348	0.0000	1.2284	0.0000
2.9835	0.1713	0.1423	0.0000	1.2562	0.0000
3.0275	0.1728	0.1499	0.0000	1.2841	0.0000
3.0714	0.1743	0.1575	0.0000	1.3119	0.0000
3.1154	0.1758	0.1652	0.0000	1.3397	0.0000
3.1593	0.1773	0.1730	0.0000	1.3676	0.0000
3.2033	0.1788	0.1808	0.0000	1.3954	0.0000
3.2473	0.1803	0.1887	0.0000	1.4233	0.0000
3.2912	0.1818	0.1967	0.0000	1.4511	0.0000
3.3352	0.1833	0.2047	0.0000	1.4789	0.0000
3.3791	0.1848	0.2128	0.0000	1.5068	0.0000
3.4231	0.1863	0.2209	0.0000	1.5346	0.0000
3.4670	0.1878	0.2291	0.0000	1.5625	0.0000
3.5110	0.1893	0.2374	0.0122	1.5903	0.0000
3.5549	0.1908	0.2458	0.1365	1.6181	0.0000
3.5989	0.1923	0.2542	0.3281	1.6460	0.0000
3.6429	0.1938	0.2627	0.5635	1.6738	0.0000
3.6868	0.1954	0.2712	0.8261	1.7016	0.0000

3.7308	0.1969	0.2799	1.0991	1.7295	0.0000
3.7747	0.1984	0.2886	1.3657	1.7573	0.0000
3.8187	0.2000	0.2973	1.6096	1.7852	0.0000
3.8626	0.2015	0.3061	1.8176	1.8130	0.0000
3.9066	0.2030	0.3150	1.9818	1.8408	0.0000
3.9505	0.2046	0.3240	2.1028	1.8687	0.0000
3.9945	0.2061	0.3330	2.1930	1.8965	0.0000
4.0000	0.2063	0.3341	2.3112	1.9000	0.0000

Surface Bio-swale

Element Flows To:

Outlet 1

StormTech 2

Outlet 2

Bio-swale

StormTech 2

Chamber Model: 3500
 Dimensions
 Max Row Length: 575
 Number of Chambers: 256
 Number of Endcaps: 8
 Top Stone Depth: 12
 Bottom Stone Depth: 12
 Discharge Structure
 Riser Height: 4.4 ft.
 Riser Diameter: 18 in.
 Orifice 1 Diameter: 1.85 in. Elevation:0 ft.
 Orifice 2 Diameter: 2.5 in. Elevation:2.25 ft.
 Orifice 3 Diameter: 2 in. Elevation:2.75 ft.
 Element Flows To:
 Outlet 1 Outlet 2

NDS 44" STORMCHAMBER WILL BE THE SPECIFIED PRODUCT. VERY SIMILAR PRODUCT TO STORMTECH 3500 CHAMBER

VOLUME OF SYSTEM DETERMINED BY NUMBER OF CHAMBERS REQUIRED

StormTech Hydraulic Table

Stage(feet)	Area(ac.)	Volume(ac-ft.)	Discharge(cfs)	Infilt(cfs)
3.0000	3.379	0.000	0.000	0.000
3.0889	3.379	0.300	0.027	0.000
3.1778	3.379	0.600	0.039	0.000
3.2667	3.379	0.901	0.048	0.000
3.3556	3.379	1.201	0.055	0.000
3.4444	3.379	1.501	0.061	0.000
3.5333	3.379	1.802	0.067	0.000
3.6222	3.379	2.102	0.073	0.000
3.7111	3.379	2.403	0.078	0.000
3.8000	3.379	2.703	0.083	0.000
3.8889	3.379	3.003	0.087	0.000
3.9778	3.379	3.304	0.091	0.000
4.0667	3.379	3.604	0.095	0.000
4.1556	3.379	3.904	0.099	0.000
4.2444	3.379	4.205	0.103	0.000
4.3333	3.379	4.505	0.107	0.000
4.4222	3.379	4.806	0.110	0.000
4.5111	3.379	5.106	0.114	0.000
4.6000	3.379	5.406	0.117	0.000
4.6889	3.379	5.707	0.120	0.000
4.7778	3.379	6.007	0.123	0.000
4.8667	3.379	6.307	0.126	0.000
4.9556	3.379	6.608	0.129	0.000
5.0444	3.379	6.908	0.132	0.000
5.1333	3.379	7.209	0.135	0.000
5.2222	3.379	7.509	0.138	0.000
5.3111	3.379	7.809	0.183	0.000
5.4000	3.379	8.110	0.209	0.000
5.4889	3.379	8.410	0.229	0.000
5.5778	3.379	8.710	0.246	0.000
5.6667	3.379	9.011	0.261	0.000
5.7556	3.379	9.311	0.282	0.000
5.8444	3.379	9.612	0.320	0.000
5.9333	3.379	9.912	0.345	0.000
6.0222	3.379	10.21	0.367	0.000
6.1111	3.379	10.51	0.386	0.000

6.2000	3.379	10.81	0.404	0.000
6.2889	3.379	11.11	0.421	0.000
6.3778	3.379	11.41	0.436	0.000
6.4667	3.379	11.71	0.451	0.000
6.5556	3.379	12.01	0.466	0.000
6.6444	3.379	12.31	0.480	0.000
6.7333	3.379	12.61	0.493	0.000
6.8222	3.379	12.91	0.506	0.000
6.9111	3.379	13.21	0.519	0.000
7.0000	3.379	13.51	0.531	0.000
7.0889	3.379	13.81	0.543	0.000
7.1778	3.379	14.11	0.555	0.000
7.2667	3.379	14.41	0.566	0.000
7.3556	3.379	14.71	0.577	0.000
7.4444	3.379	15.01	0.737	0.000
7.5333	3.379	15.31	1.370	0.000
7.6222	3.379	15.62	2.246	0.000
7.7111	3.379	15.92	3.247	0.000
7.8000	3.379	16.22	4.261	0.000
7.8889	3.379	16.52	5.177	0.000
7.9778	3.379	16.82	5.905	0.000
8.0667	3.379	17.12	6.413	0.000
8.1556	3.379	17.42	6.828	0.000
8.2444	3.379	17.72	7.189	0.000
8.3333	3.379	18.02	7.533	0.000
8.4222	3.379	18.32	7.860	0.000
8.5111	3.379	18.62	8.174	0.000
8.6000	3.379	18.92	8.476	0.000
8.6889	3.379	19.22	8.767	0.000
8.7778	3.379	19.52	9.048	0.000
8.8667	3.379	19.82	9.321	0.000
8.9556	3.379	20.12	9.586	0.000
9.0444	3.379	20.42	9.843	0.000
9.1333	3.379	20.72	10.09	0.000
9.2222	3.379	21.02	10.33	0.000
9.3111	3.379	21.32	10.57	0.000
9.4000	3.379	21.62	10.81	0.000
9.4889	3.379	21.92	11.03	0.000
9.5778	3.379	22.22	11.26	0.000
9.6667	3.379	22.52	11.48	0.000
9.7556	3.379	22.82	11.69	0.000
9.8444	3.379	23.12	11.90	0.000
9.9333	3.379	23.42	12.11	0.000
10.022	3.379	23.73	12.31	0.000
10.111	3.379	24.03	12.51	0.000
10.200	3.379	24.33	12.71	0.000
10.289	3.379	24.63	12.90	0.000
10.378	3.379	24.93	13.09	0.000
10.467	3.379	25.23	13.28	0.000
10.556	3.379	25.53	13.47	0.000
10.644	3.379	25.83	13.65	0.000
10.733	3.379	26.13	13.83	0.000
10.822	3.379	26.43	14.01	0.000
10.911	3.379	26.73	14.19	0.000
11.000	3.379	27.03	14.36	0.000
11.089	3.379	27.33	14.53	0.000
11.178	0.000	0.000	14.70	0.000

Analysis Results

POC 1

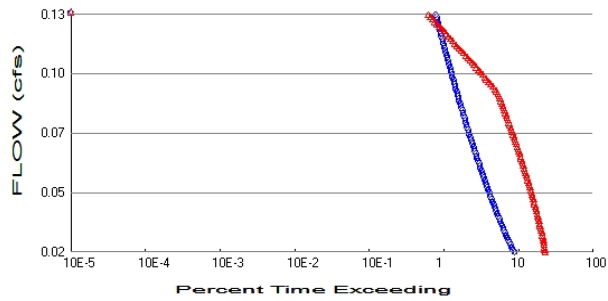
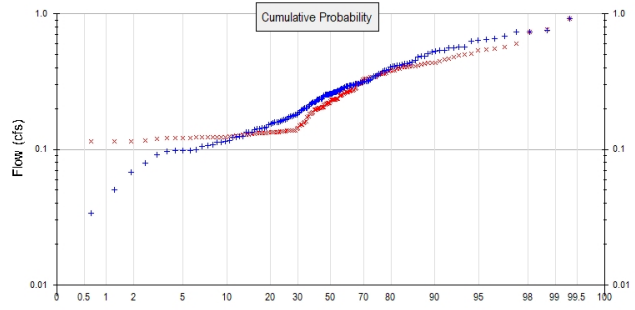
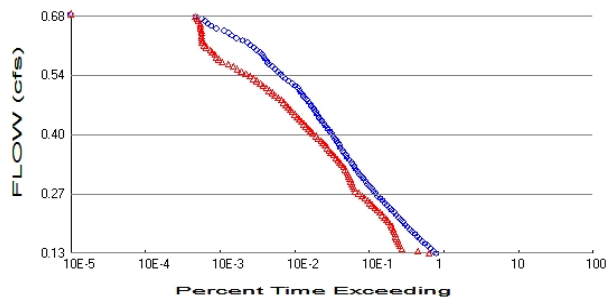

+ Predeveloped x Mitigated

Predeveloped Landuse Totals for POC #1

Total Pervious Area: 9.88
Total Impervious Area: 0

Mitigated Landuse Totals for POC #1

Total Pervious Area: 3.38
Total Impervious Area: 6.3

Flow Frequency Method: Log Pearson Type III 17B

Flow Frequency Return Periods for Predeveloped. POC #1

Return Period	Flow(cfs)
2 year	0.256836
5 year	0.404014
10 year	0.495998
25 year	0.60346
50 year	0.676874
100 year	0.744802

Flow Frequency Return Periods for Mitigated. POC #1

Return Period	Flow(cfs)
2 year	0.222795
5 year	0.346003
10 year	0.441908
25 year	0.580119
50 year	0.695949
100 year	0.823244

Annual Peaks

Annual Peaks for Predeveloped and Mitigated. POC #1

Year	Predeveloped	Mitigated
1902	0.202	0.262
1903	0.158	0.130
1904	0.320	0.186
1905	0.134	0.319
1906	0.068	0.123
1907	0.417	0.404
1908	0.297	0.159
1909	0.302	0.341
1910	0.426	0.376
1911	0.259	0.220
1912	0.916	0.354
1913	0.378	0.330
1914	0.098	0.130
1915	0.165	0.162
1916	0.248	0.219
1917	0.100	0.123
1918	0.254	0.252
1919	0.193	0.215
1920	0.263	0.143
1921	0.293	0.206
1922	0.303	0.343
1923	0.233	0.285
1924	0.115	0.133
1925	0.146	0.134
1926	0.257	0.182
1927	0.172	0.153
1928	0.201	0.133
1929	0.439	0.343
1930	0.266	0.134
1931	0.256	0.201
1932	0.219	0.200
1933	0.196	0.264
1934	0.539	0.413
1935	0.263	0.184
1936	0.209	0.135
1937	0.385	0.364
1938	0.222	0.236
1939	0.021	0.131
1940	0.236	0.227
1941	0.122	0.122
1942	0.350	0.446
1943	0.184	0.135
1944	0.418	0.535
1945	0.292	0.261
1946	0.176	0.125
1947	0.112	0.233
1948	0.565	0.492
1949	0.484	0.541
1950	0.153	0.129
1951	0.158	0.125
1952	0.754	0.765
1953	0.652	0.601
1954	0.253	0.138
1955	0.201	0.134
1956	0.091	0.114
1957	0.314	0.277

1958	0.650	0.502
1959	0.403	0.404
1960	0.117	0.138
1961	0.435	0.421
1962	0.244	0.265
1963	0.114	0.134
1964	0.124	0.173
1965	0.484	0.431
1966	0.144	0.199
1967	0.215	0.127
1968	0.224	0.339
1969	0.226	0.187
1970	0.335	0.332
1971	0.526	0.435
1972	0.344	0.250
1973	0.413	0.436
1974	0.255	0.360
1975	0.562	0.464
1976	0.279	0.232
1977	0.098	0.126
1978	0.506	0.409
1979	0.134	0.119
1980	0.260	0.195
1981	0.264	0.205
1982	0.105	0.128
1983	0.424	0.364
1984	0.236	0.175
1985	0.274	0.268
1986	0.255	0.232
1987	0.479	0.477
1988	0.325	0.204
1989	0.280	0.235
1990	0.308	0.305
1991	0.258	0.264
1992	0.361	0.232
1993	0.345	0.271
1994	0.534	0.458
1995	0.108	0.122
1996	0.530	0.410
1997	0.231	0.132
1998	0.290	0.250
1999	0.050	0.114
2000	0.179	0.156
2001	0.124	0.122
2002	0.383	0.139
2003	0.305	0.359
2004	0.306	0.232
2005	0.558	0.136
2006	0.164	0.124
2007	0.158	0.279
2008	0.268	0.196
2009	0.181	0.134
2010	0.167	0.392
2011	0.134	0.121
2012	0.273	0.382
2013	0.155	0.137
2014	0.107	0.115
2015	0.247	0.212

2016	0.097	0.122
2017	0.409	0.553
2018	0.688	0.507
2019	0.736	0.916
2020	0.235	0.129
2021	0.361	0.303
2022	0.145	0.134
2023	0.297	0.236
2024	0.734	0.218
2025	0.272	0.233
2026	0.425	0.395
2027	0.156	0.196
2028	0.141	0.121
2029	0.297	0.201
2030	0.567	0.429
2031	0.181	0.131
2032	0.097	0.108
2033	0.160	0.122
2034	0.176	0.326
2035	0.624	0.568
2036	0.317	0.249
2037	0.079	0.138
2038	0.313	0.405
2039	0.034	0.115
2040	0.141	0.139
2041	0.199	0.153
2042	0.641	0.734
2043	0.289	0.384
2044	0.380	0.381
2045	0.255	0.142
2046	0.287	0.272
2047	0.224	0.136
2048	0.306	0.256
2049	0.282	0.272
2050	0.217	0.150
2051	0.324	0.413
2052	0.168	0.332
2053	0.295	0.358
2054	0.318	0.303
2055	0.139	0.120
2056	0.122	0.216
2057	0.188	0.220
2058	0.232	0.203
2059	0.455	0.332

Ranked Annual Peaks

Ranked Annual Peaks for Predeveloped and Mitigated. POC #1

Rank	Predeveloped	Mitigated
1	0.9160	0.9161
2	0.7540	0.7647
3	0.7361	0.7339
4	0.7336	0.6008
5	0.6878	0.5684
6	0.6524	0.5526
7	0.6501	0.5413
8	0.6412	0.5348
9	0.6243	0.5073
10	0.5666	0.5018

11	0.5653	0.4916
12	0.5622	0.4768
13	0.5576	0.4635
14	0.5386	0.4584
15	0.5337	0.4460
16	0.5300	0.4364
17	0.5257	0.4345
18	0.5056	0.4314
19	0.4843	0.4293
20	0.4841	0.4209
21	0.4791	0.4134
22	0.4549	0.4125
23	0.4387	0.4103
24	0.4348	0.4091
25	0.4255	0.4049
26	0.4254	0.4038
27	0.4236	0.4037
28	0.4176	0.3945
29	0.4171	0.3924
30	0.4133	0.3836
31	0.4092	0.3822
32	0.4029	0.3808
33	0.3853	0.3755
34	0.3834	0.3640
35	0.3804	0.3636
36	0.3785	0.3601
37	0.3613	0.3591
38	0.3608	0.3580
39	0.3498	0.3536
40	0.3450	0.3432
41	0.3444	0.3432
42	0.3350	0.3409
43	0.3254	0.3390
44	0.3235	0.3325
45	0.3200	0.3321
46	0.3181	0.3316
47	0.3165	0.3302
48	0.3140	0.3257
49	0.3126	0.3190
50	0.3084	0.3053
51	0.3064	0.3033
52	0.3060	0.3032
53	0.3045	0.2851
54	0.3034	0.2794
55	0.3018	0.2766
56	0.2971	0.2725
57	0.2970	0.2718
58	0.2967	0.2708
59	0.2954	0.2680
60	0.2928	0.2646
61	0.2924	0.2644
62	0.2902	0.2640
63	0.2894	0.2620
64	0.2873	0.2614
65	0.2820	0.2562
66	0.2805	0.2521
67	0.2788	0.2497
68	0.2741	0.2497

69	0.2727	0.2487
70	0.2717	0.2359
71	0.2680	0.2357
72	0.2656	0.2355
73	0.2639	0.2330
74	0.2631	0.2325
75	0.2629	0.2324
76	0.2602	0.2324
77	0.2586	0.2322
78	0.2583	0.2319
79	0.2569	0.2269
80	0.2560	0.2201
81	0.2549	0.2196
82	0.2549	0.2185
83	0.2545	0.2176
84	0.2542	0.2159
85	0.2529	0.2151
86	0.2481	0.2125
87	0.2470	0.2058
88	0.2443	0.2053
89	0.2365	0.2039
90	0.2358	0.2033
91	0.2352	0.2008
92	0.2331	0.2006
93	0.2323	0.1998
94	0.2313	0.1986
95	0.2261	0.1963
96	0.2238	0.1962
97	0.2238	0.1952
98	0.2222	0.1873
99	0.2187	0.1863
100	0.2169	0.1837
101	0.2147	0.1816
102	0.2087	0.1753
103	0.2019	0.1732
104	0.2015	0.1620
105	0.2007	0.1589
106	0.1988	0.1558
107	0.1963	0.1527
108	0.1929	0.1525
109	0.1882	0.1498
110	0.1845	0.1433
111	0.1814	0.1422
112	0.1808	0.1387
113	0.1790	0.1385
114	0.1764	0.1384
115	0.1761	0.1381
116	0.1720	0.1376
117	0.1682	0.1370
118	0.1668	0.1362
119	0.1653	0.1358
120	0.1643	0.1354
121	0.1600	0.1352
122	0.1582	0.1344
123	0.1580	0.1342
124	0.1578	0.1341
125	0.1562	0.1341
126	0.1548	0.1339

127	0.1526	0.1337
128	0.1459	0.1326
129	0.1445	0.1325
130	0.1436	0.1325
131	0.1411	0.1313
132	0.1409	0.1313
133	0.1394	0.1305
134	0.1345	0.1301
135	0.1341	0.1290
136	0.1339	0.1285
137	0.1243	0.1284
138	0.1240	0.1272
139	0.1224	0.1258
140	0.1223	0.1254
141	0.1169	0.1250
142	0.1152	0.1236
143	0.1135	0.1226
144	0.1122	0.1225
145	0.1079	0.1224
146	0.1072	0.1224
147	0.1047	0.1224
148	0.1000	0.1221
149	0.0979	0.1216
150	0.0978	0.1211
151	0.0973	0.1211
152	0.0971	0.1205
153	0.0910	0.1192
154	0.0788	0.1154
155	0.0678	0.1148
156	0.0501	0.1143
157	0.0339	0.1142
158	0.0213	0.1075

LID Duration Flows

The Development **Failed** :duration increase for more than 0% of the flows.

Flow(cfs)	Predev	Mit	Percentage	Pass/Fail
0.0205	485642	1255933	258	Fail
0.0216	468025	1242636	265	Fail
0.0227	451017	1230448	272	Fail
0.0238	435061	1218260	280	Fail
0.0249	419881	1206626	287	Fail
0.0260	405533	1195546	294	Fail
0.0271	391960	1181696	301	Fail
0.0282	379217	1159535	305	Fail
0.0293	366808	1137929	310	Fail
0.0304	355007	1116323	314	Fail
0.0314	343872	1096379	318	Fail
0.0325	333069	1076434	323	Fail
0.0336	322653	1057598	327	Fail
0.0347	312792	1039316	332	Fail
0.0358	303374	1021588	336	Fail
0.0369	294288	1004414	341	Fail
0.0380	285867	987239	345	Fail
0.0391	277668	967295	348	Fail
0.0402	269857	947905	351	Fail
0.0412	262211	929069	354	Fail
0.0423	254843	910787	357	Fail
0.0434	247696	893058	360	Fail
0.0445	240882	875884	363	Fail
0.0456	234345	859264	366	Fail
0.0467	228029	842090	369	Fail
0.0478	221990	824362	371	Fail
0.0489	216173	806633	373	Fail
0.0500	210578	789459	374	Fail
0.0511	205149	772839	376	Fail
0.0521	199775	756773	378	Fail
0.0532	194622	740707	380	Fail
0.0543	189581	724640	382	Fail
0.0554	184761	707466	382	Fail
0.0565	179997	691400	384	Fail
0.0576	175398	675888	385	Fail
0.0587	170966	660376	386	Fail
0.0598	166756	645971	387	Fail
0.0609	162656	631013	387	Fail
0.0620	158612	616055	388	Fail
0.0630	154679	601651	388	Fail
0.0641	150911	587247	389	Fail
0.0652	147310	573951	389	Fail
0.0663	143820	560100	389	Fail
0.0674	140330	546195	389	Fail
0.0685	137061	532566	388	Fail
0.0696	133793	519436	388	Fail
0.0707	130635	506860	387	Fail
0.0718	127588	494174	387	Fail
0.0728	124651	481487	386	Fail
0.0739	121771	469299	385	Fail
0.0750	118945	457443	384	Fail
0.0761	116286	445864	383	Fail
0.0772	113682	433953	381	Fail

0.0783	111134	422319	380	Fail
0.0794	108641	411294	378	Fail
0.0805	106258	400547	376	Fail
0.0816	103932	389744	374	Fail
0.0827	101660	379384	373	Fail
0.0837	99389	369190	371	Fail
0.0848	97117	359218	369	Fail
0.0859	95012	349523	367	Fail
0.0870	92962	339938	365	Fail
0.0881	91023	330686	363	Fail
0.0892	89084	321767	361	Fail
0.0903	87145	312681	358	Fail
0.0914	85317	304039	356	Fail
0.0925	83544	295673	353	Fail
0.0936	81771	282045	344	Fail
0.0946	80165	265258	330	Fail
0.0957	78503	249524	317	Fail
0.0968	76841	234289	304	Fail
0.0979	75234	219996	292	Fail
0.0990	73683	206478	280	Fail
0.1001	72298	194899	269	Fail
0.1012	70802	183099	258	Fail
0.1023	69362	171742	247	Fail
0.1034	67866	161271	237	Fail
0.1044	66481	150801	226	Fail
0.1055	65096	141272	217	Fail
0.1066	63766	132241	207	Fail
0.1077	62437	123599	197	Fail
0.1088	61162	115289	188	Fail
0.1099	60054	108197	180	Fail
0.1110	58835	100829	171	Fail
0.1121	57672	94236	163	Fail
0.1132	56509	88087	155	Fail
0.1143	55351	82270	148	Fail
0.1153	54282	76841	141	Fail
0.1164	53229	71965	135	Fail
0.1175	52193	67201	128	Fail
0.1186	51201	62935	122	Fail
0.1197	50199	58669	116	Fail
0.1208	49329	55201	111	Fail
0.1219	48354	51528	106	Fail
0.1230	47428	48132	101	Fail
0.1241	46514	44952	96	Pass
0.1251	45667	41983	91	Pass
0.1262	44814	39041	87	Pass
0.1273	43938	36454	82	Pass
0.1284	43157	33988	78	Pass

The development has an increase in flow durations from 1/2 Predeveloped 2 year flow to the 2 year flow or more than a 10% increase from the 2 year to the 50 year flow.

The development has an increase in flow durations for more than 50% of the flows for the range of the duration analysis.

Duration Flows

The Facility PASSED

Flow(cfs)	Predev	Mit	Percentage	Pass/Fail
0.1284	43440	34858	80	Pass
0.1340	40082	24626	61	Pass
0.1395	36465	15091	41	Pass
0.1450	33301	14160	42	Pass
0.1506	30880	13773	44	Pass
0.1561	28360	13296	46	Pass
0.1617	26382	12914	48	Pass
0.1672	24210	12521	51	Pass
0.1727	22487	12221	54	Pass
0.1783	20698	11811	57	Pass
0.1838	19351	11523	59	Pass
0.1894	17928	11147	62	Pass
0.1949	16858	10703	63	Pass
0.2004	15590	10016	64	Pass
0.2060	14665	9474	64	Pass
0.2115	13640	8853	64	Pass
0.2171	12676	8205	64	Pass
0.2226	11917	7673	64	Pass
0.2281	10975	7091	64	Pass
0.2337	10299	6620	64	Pass
0.2392	9529	6055	63	Pass
0.2448	8914	5662	63	Pass
0.2503	8260	5207	63	Pass
0.2558	7756	4842	62	Pass
0.2614	7169	4422	61	Pass
0.2669	6731	4032	59	Pass
0.2725	6288	3632	57	Pass
0.2780	5944	3465	58	Pass
0.2835	5546	3336	60	Pass
0.2891	5180	3242	62	Pass
0.2946	4914	3153	64	Pass
0.3002	4621	3041	65	Pass
0.3057	4355	2954	67	Pass
0.3112	4065	2859	70	Pass
0.3168	3867	2773	71	Pass
0.3223	3667	2640	71	Pass
0.3279	3506	2514	71	Pass
0.3334	3324	2347	70	Pass
0.3389	3179	2234	70	Pass
0.3445	2995	2096	69	Pass
0.3500	2800	1960	70	Pass
0.3556	2683	1838	68	Pass
0.3611	2524	1690	66	Pass
0.3666	2427	1600	65	Pass
0.3722	2295	1507	65	Pass
0.3777	2210	1420	64	Pass
0.3833	2104	1328	63	Pass
0.3888	2022	1248	61	Pass
0.3943	1922	1137	59	Pass
0.3999	1820	1070	58	Pass
0.4054	1717	967	56	Pass
0.4110	1634	905	55	Pass
0.4165	1532	853	55	Pass

0.4220	1446	793	54	Pass
0.4276	1370	739	53	Pass
0.4331	1278	682	53	Pass
0.4387	1217	637	52	Pass
0.4442	1156	598	51	Pass
0.4497	1109	551	49	Pass
0.4553	1055	512	48	Pass
0.4608	1012	481	47	Pass
0.4664	957	449	46	Pass
0.4719	909	425	46	Pass
0.4774	855	394	46	Pass
0.4830	801	366	45	Pass
0.4885	756	330	43	Pass
0.4941	714	300	42	Pass
0.4996	683	279	40	Pass
0.5051	644	253	39	Pass
0.5107	608	230	37	Pass
0.5162	561	209	37	Pass
0.5218	516	192	37	Pass
0.5273	458	171	37	Pass
0.5328	416	157	37	Pass
0.5384	381	139	36	Pass
0.5439	356	123	34	Pass
0.5495	327	107	32	Pass
0.5550	302	94	31	Pass
0.5605	273	83	30	Pass
0.5661	249	71	28	Pass
0.5716	237	59	24	Pass
0.5772	222	53	23	Pass
0.5827	214	49	22	Pass
0.5882	200	47	23	Pass
0.5938	187	43	22	Pass
0.5993	170	41	24	Pass
0.6049	157	36	22	Pass
0.6104	141	34	24	Pass
0.6159	130	32	24	Pass
0.6215	111	32	28	Pass
0.6270	91	31	34	Pass
0.6326	80	31	38	Pass
0.6381	71	31	43	Pass
0.6436	63	31	49	Pass
0.6492	49	30	61	Pass
0.6547	42	30	71	Pass
0.6603	38	30	78	Pass
0.6658	35	28	80	Pass
0.6713	31	27	87	Pass
0.6769	26	26	100	Pass

Water Quality

Water Quality BMP Flow and Volume for POC #1

On-line facility volume: 0.4396 acre-feet

On-line facility target flow: 0.3093 cfs.

Adjusted for 15 min: 0.3093 cfs.

Off-line facility target flow: 0.1697 cfs.

Adjusted for 15 min: 0.1697 cfs.

LID Report

LID Technique	Used for Treatment ?	Total Volume Needs Treatment (ac-ft)	Volume Through Facility (ac-ft)	Infiltration Volume (ac-ft)	Cumulative Volume Infiltration Credit	Percent Volume Infiltrated	Water Quality	Percent Water Quality Treated	Comment
TION PLANTER POC	<input checked="" type="checkbox"/>	722.05	793.46	793.42	<input checked="" type="checkbox"/>	100.00	793.42	100.00	Treat. Credit
StormTech 2 POC	<input type="checkbox"/>	1675.99			<input type="checkbox"/>	0.00			
Bio-swale	<input checked="" type="checkbox"/>	1675.86	1841.61	0.00	<input type="checkbox"/>	0.00	1840.71	99.95	Treat. Credit
Total Volume Infiltrated		4073.90	2635.07	793.42		17.72	2634.13	2634 / 2635 = 100%	Treat. Credit = 100%
Compliance with LID Standard 8% of 2-yr to 50% of 2-yr									Duration Analysis Result = Failed

Model Default Modifications

Total of 0 changes have been made.

PERLND Changes

No PERLND changes have been made.

IMPLND Changes

No IMPLND changes have been made.

Appendix
Predeveloped Schematic



SHBTC DB -
EG
9.88ac

See Comment Pg 245 regarding Wetland
bypass.[Storm Report; Pg 276 of 347]

Mitigated Schematic

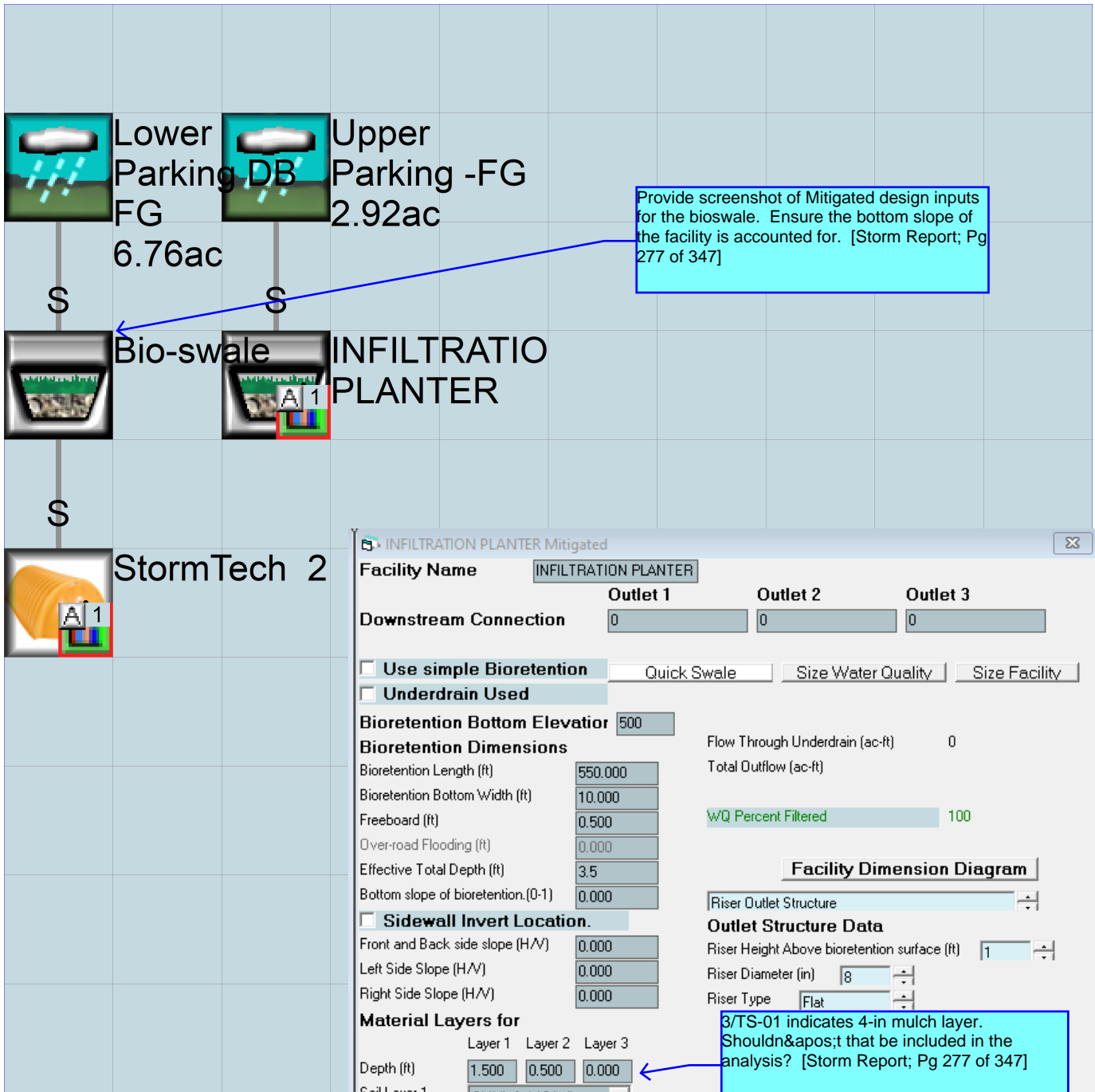

INFILTRATION PLANTER Mitigated

Facility Name: INFILTRATION PLANTER

Outlet 1: 0, Outlet 2: 0, Outlet 3: 0

Downstream Connection: 0, 0, 0

Use simple Bioretention Quick Swale Size Water Quality Size Facility

Underdrain Used

Bioretention Bottom Elevation: 500

Flow Through Underdrain (ac-ft): 0

Total Outflow (ac-ft): 0

Bioretention Dimensions:

- Bioretention Length (ft): 550.000
- Bioretention Bottom Width (ft): 10.000
- Freeboard (ft): 0.500
- Over-road Flooding (ft): 0.000
- Effective Total Depth (ft): 3.5
- Bottom slope of bioretention.(0-1): 0.000

WQ Percent Filtered: 100

Sidewall Invert Location.

Front and Back side slope (H/V): 0.000

Left Side Slope (H/V): 0.000

Right Side Slope (H/V): 0.000

Facility Dimension Diagram

Riser Outlet Structure: [dropdown]

Outlet Structure Data:

- Riser Height Above bioretention surface (ft): 1
- Riser Diameter (in): 8
- Riser Type: Flat

3/TS-01 indicates 4-in mulch layer. Shouldn't that be included in the analysis? [Storm Report; Pg 277 of 347]

Material Layers for:

	Layer 1	Layer 2	Layer 3
Depth (ft)	1.500	0.500	0.000
Soil Layer 1	SMMWw 12 in/hr		
Soil Layer 2	GRAVEL		
Soil Layer 3	GRAVEL		

Edit Soil Types

KSat Safety Factor: None 2 4

Orifice Diameter Height

Number	Diameter (in)	Height (ft)
1	0	0
2	0	0
3	0	0

Bioretention Volume at Riser Head (ac-ft): .302

Show Bioretention: Open Table

Native Infiltration: Yes

Total Volume Infiltrated (ac-ft): 793.423

Measured Infiltration Rate (in/hr): 2.9

Total Volume Through Riser (ac-ft): 0.038

Reduction Factor (infiltr*factor): 1

Total Volume Through Facility(ac-ft): 793.461

Use Wetted Surface Area (sidewalls): NO

Percent Infiltrated: 100

Total Inflow ac-ft: 824.07

Precipitation on Facility (acre-ft): 55.856

Evaporation from Facility (acre-ft): 30.615

Predeveloped UCI File

RUN

GLOBAL
WWM4 model simulation
START 1901 10 01 END 2059 09 30
RUN INTERP OUTPUT LEVEL 3 0
RESUME 0 RUN 1 UNIT SYSTEM 1
END GLOBAL

FILES
<File> <Un#> <-----File Name----->***
<-ID-> ***
WDM 26 SHBTC Parking.wdm
MESSU 25 PreSHBTC Parking.MES
27 PreSHBTC Parking.L61
28 PreSHBTC Parking.L62
30 POCSHBTC Parking1.dat
END FILES

OPN SEQUENCE
INGRP INDELT 00:15
PERLND 11
PERLND 12
PERLND 19
COPY 501
DISPLY 1
END INGRP

END OPN SEQUENCE

DISPLY

DISPLY-INF01

#	-	#	Title	TRAN	PIVL	DIG1	FIL1	PYR	DIG2	FIL2	YRND
1			SHBTC DB - EG	MAX				1	2	30	9

END DISPLY-INF01

END DISPLY

COPY

TIMESERIES

#	-	#	NPT	NMN	***
1			1	1	
501			1	1	

END TIMESERIES

END COPY

GENER

OPCODE

#	#	OPCD	***

END OPCODE

PARM

#	#	K	***

END PARM

END GENER

PERLND

GEN-INFO

<PLS >	<-----Name----->	NBLKS	Unit-systems		Printer		***
#	-	#	User	t-series	Engl	Metr	***
				in	out		***

11			C, Forest, Mod	1	1	1	1	27	0
12			C, Forest, Steep	1	1	1	1	27	0
19			SAT, Forest, Flat	1	1	1	1	27	0

END GEN-INFO

*** Section PWATER***

ACTIVITY

<PLS >	***** Active Sections *****													***	
#	-	#	ATMP	SNOW	PWAT	SED	PST	PWG	PQAL	MSTL	PEST	NITR	PHOS	TRAC	***
11			0	0	1	0	0	0	0	0	0	0	0	0	
12			0	0	1	0	0	0	0	0	0	0	0	0	
19			0	0	1	0	0	0	0	0	0	0	0	0	

END ACTIVITY

```

PRINT-INFO
<PLS > ***** Print-flags ***** PIVL  PYR
# - # ATMP SNOW PWAT  SED  PST  PWG  PQAL MSTL PEST NITR PHOS TRAC  *****
11   0   0   4   0   0   0   0   0   0   0   0   0   0   1   9
12   0   0   4   0   0   0   0   0   0   0   0   0   0   1   9
19   0   0   4   0   0   0   0   0   0   0   0   0   0   1   9
END PRINT-INFO

```

```

PWAT-PARM1
<PLS > PWATER variable monthly parameter value flags ***
# - # CSNO RTOP UZFG  VCS  VUZ  VNN VIFW VIRC  VLE INFC  HWT ***
11   0   0   0   0   0   0   0   0   0   0   0
12   0   0   0   0   0   0   0   0   0   0   0
19   0   0   0   0   0   0   0   0   0   0   0
END PWAT-PARM1

```

```

PWAT-PARM2
<PLS > PWATER input info: Part 2 *****
# - # ***FOREST  LZSN  INFILT  LRSUR  SLSUR  KVARY  AGWRC
11   0   4.5  0.08  400  0.1  0.5  0.996
12   0   4.5  0.08  400  0.15  0.5  0.996
19   0   4    2    100  0.001  0.5  0.996
END PWAT-PARM2

```

```

PWAT-PARM3
<PLS > PWATER input info: Part 3 *****
# - # ***PETMAX  PETMIN  INFEXP  INFILD  DEEPFR  BASETP  AGWETP
11   0   0    2    2    0    0    0
12   0   0    2    2    0    0    0
19   0   0   10   2    0    0    0.7
END PWAT-PARM3

```

```

PWAT-PARM4
<PLS > PWATER input info: Part 4 *****
# - # CEPSC  UZSN  NSUR  INTFW  IRC  LZETP ***
11   0.2  0.5  0.35  6    0.5  0.7
12   0.2  0.3  0.35  6    0.3  0.7
19   0.2  3    0.5  1    0.7  0.8
END PWAT-PARM4

```

```

PWAT-STATE1
<PLS > *** Initial conditions at start of simulation
ran from 1990 to end of 1992 (pat 1-11-95) RUN 21 ***
# - # *** CEPS  SURS  UZS  IFWS  LZS  AGWS  GWVS
11   0   0    0    0    2.5  1    0
12   0   0    0    0    2.5  1    0
19   0   0    0    0    4.2  1    0
END PWAT-STATE1

```

END PERLND

IMPLND

```

GEN-INFO
<PLS ><-----Name-----> Unit-systems Printer ***
# - # User t-series Engl Metr ***
in out ***
END GEN-INFO
*** Section IWATER***

```

```

ACTIVITY
<PLS > ***** Active Sections *****
# - # ATMP SNOW IWAT  SLD  IWG IQAL  ***
END ACTIVITY

```

```

PRINT-INFO
<ILS > ***** Print-flags ***** PIVL  PYR
# - # ATMP SNOW IWAT  SLD  IWG IQAL  *****
END PRINT-INFO

```

```

IWAT-PARM1
<PLS > IWATER variable monthly parameter value flags ***

```

```

# - # CSNO RTOP VRS VNN RTLI      ***
END IWAT-PARM1

IWAT-PARM2
  <PLS >      IWATER input info: Part 2      ***
# - # *** LSUR      SLSUR      NSUR      RETSC
END IWAT-PARM2

IWAT-PARM3
  <PLS >      IWATER input info: Part 3      ***
# - # ***PETMAX      PETMIN
END IWAT-PARM3

IWAT-STATE1
  <PLS > *** Initial conditions at start of simulation
# - # *** RETS      SURS
END IWAT-STATE1

END IMPLND

SCHEMATIC
<-Source->          <--Area-->          <-Target->      MBLK      ***
<Name> #            <-factor->          <Name> #      Tbl#      ***
SHBTC DB - EG***
PERLND 11           4.78          COPY    501     12
PERLND 11           4.78          COPY    501     13
PERLND 12           5            COPY    501     12
PERLND 12           5            COPY    501     13
PERLND 19           0.1          COPY    501     12
PERLND 19           0.1          COPY    501     13

*****Routing*****
END SCHEMATIC

NETWORK
<-Volume-> <-Grp> <-Member-><--Mult-->Tran <-Target vols> <-Grp> <-Member->  ***
<Name> # <Name> # #<-factor->strg <Name> # # <Name> # #  ***
COPY 501 OUTPUT MEAN 1 1 48.4 DISPLY 1 INPUT TIMSER 1

<-Volume-> <-Grp> <-Member-><--Mult-->Tran <-Target vols> <-Grp> <-Member->  ***
<Name> # <Name> # #<-factor->strg <Name> # # <Name> # #  ***
END NETWORK

RCHRES
GEN-INFO
RCHRES      Name      Nexits      Unit Systems      Printer      ***
# - #<-----><----> User T-series  Engl Metr LKFG      ***
              in out      ***

END GEN-INFO
*** Section RCHRES***

ACTIVITY
  <PLS > ***** Active Sections *****
# - # HYFG ADFG CNFG HTFG SDFG GQFG OXFG NUFG PKFG PHFG ***
END ACTIVITY

PRINT-INFO
  <PLS > ***** Print-flags ***** PIVL  PYR
# - # HYDR ADCA CONS HEAT SED  GQL  OXRX NUTR PLNK PHCB PIVL  PYR *****
END PRINT-INFO

HYDR-PARM1
  RCHRES  Flags for each HYDR Section      ***
# - #    VC A1 A2 A3  ODFVFG for each *** ODGTFG for each  FUNCT for each
          FG FG FG FG  possible exit *** possible exit  possible exit
          * * * * * * * * * * * * * * * * * * * * * * * *
END HYDR-PARM1

```



```

HYDR-PARM2
# - # FTABNO LEN DELTH STCOR KS DB50 ***
<-----><-----><-----><-----><-----><-----><-----> ***
END HYDR-PARM2
HYDR-INIT
RCHRES Initial conditions for each HYDR section ***
# - # *** VOL Initial value of COLIND Initial value of OUTDGT
*** ac-ft for each possible exit for each possible exit
<-----><-----> <-----><-----><-----><-----> *** <-----><-----><-----><-----><----->
END HYDR-INIT
END RCHRES

SPEC-ACTIONS
END SPEC-ACTIONS
FTABLES
END FTABLES

EXT SOURCES
<-Volume-> <Member> SsysSgap<--Mult-->Tran <-Target vols> <-Grp> <-Member-> ***
<Name> # <Name> # tem strg<-factor->strg <Name> # # <Name> # # ***
WDM 2 PREC ENGL 1 PERLND 1 999 EXTNL PREC
WDM 2 PREC ENGL 1 IMPLND 1 999 EXTNL PREC
WDM 1 EVAP ENGL 1 PERLND 1 999 EXTNL PETINP
WDM 1 EVAP ENGL 1 IMPLND 1 999 EXTNL PETINP

END EXT SOURCES

EXT TARGETS
<-Volume-> <-Grp> <-Member-><--Mult-->Tran <-Volume-> <Member> Tsys Tgap Amd ***
<Name> # <Name> # #<-factor->strg <Name> # <Name> tem strg strg***
COPY 501 OUTPUT MEAN 1 1 48.4 WDM 501 FLOW ENGL REPL
END EXT TARGETS

MASS-LINK
<Volume> <-Grp> <-Member-><--Mult--> <Target> <-Grp> <-Member->***
<Name> <Name> # #<-factor-> <Name> <Name> # #***
MASS-LINK 12
PERLND PWATER SURO 0.083333 COPY INPUT MEAN
END MASS-LINK 12

MASS-LINK 13
PERLND PWATER IFWO 0.083333 COPY INPUT MEAN
END MASS-LINK 13

END MASS-LINK

END RUN

```

Mitigated UCI File

RUN

GLOBAL

```
WVHM4 model simulation
START      1901 10 01      END      2059 09 30
RUN INTERP OUTPUT LEVEL   3      0
RESUME     0 RUN         1
UNIT SYSTEM                1
END GLOBAL
```

FILES

```
<File> <Un#> <-----File Name----->***
<-ID->                                     ***
WDM      26      SHBTC Parking.wdm
MESSU    25      MitSHBTC Parking.MES
          27      MitSHBTC Parking.L61
          28      MitSHBTC Parking.L62
          30      POCSHBTC Parking1.dat
```

END FILES

OPN SEQUENCE

INGRP INDELT 00:15

```
PERLND 11
PERLND 17
IMPLND 2
PERLND 16
PERLND 18
PERLND 19
PERLND 12
IMPLND 1
GENER 2
RCHRES 1
RCHRES 2
GENER 4
RCHRES 3
RCHRES 4
RCHRES 5
COPY 1
COPY 501
DISPLY 1
```

END INGRP

END OPN SEQUENCE

DISPLY

DISPLY-INFO1

```
# - #<-----Title----->***TRAN PIVL DIG1 FIL1 PYR DIG2 FIL2 YRND
1 Surface TION PLANTER MAX 1 2 30 9
```

END DISPLY-INFO1

END DISPLY

COPY

TIMESERIES

```
# - # NPT NMN ***
1 1 1
501 1 1
```

END TIMESERIES

END COPY

GENER

OPCODE

```
# # OPCODE ***
2 24
4 24
```

END OPCODE

PARM

```
# # K ***
2 0.
4 0.
```

END PARM

END GENER

PERLND

GEN-INFO

```

<PLS ><-----Name----->NBLKS      Unit-systems      Printer ***
# - #      User      t-series      Engl Metr ***
              in      out      ***
11      C, Forest, Mod      1      1      1      1      27      0
17      C, Lawn, Mod      1      1      1      1      27      0
16      C, Lawn, Flat      1      1      1      1      27      0
18      C, Lawn, Steep      1      1      1      1      27      0
19      SAT, Forest, Flat      1      1      1      1      27      0
12      C, Forest, Steep      1      1      1      1      27      0

```

END GEN-INFO

*** Section PWATER***

ACTIVITY

```

<PLS > ***** Active Sections *****
# - # ATMP SNOW PWAT SED PST PWG PQAL MSTL PEST NITR PHOS TRAC ***
11      0      0      1      0      0      0      0      0      0      0      0      0      0
17      0      0      1      0      0      0      0      0      0      0      0      0      0
16      0      0      1      0      0      0      0      0      0      0      0      0      0
18      0      0      1      0      0      0      0      0      0      0      0      0      0
19      0      0      1      0      0      0      0      0      0      0      0      0      0
12      0      0      1      0      0      0      0      0      0      0      0      0      0

```

END ACTIVITY

PRINT-INFO

```

<PLS > ***** Print-flags ***** PIVL PYR
# - # ATMP SNOW PWAT SED PST PWG PQAL MSTL PEST NITR PHOS TRAC *****
11      0      0      4      0      0      0      0      0      0      0      0      0      0      1      9
17      0      0      4      0      0      0      0      0      0      0      0      0      0      1      9
16      0      0      4      0      0      0      0      0      0      0      0      0      0      1      9
18      0      0      4      0      0      0      0      0      0      0      0      0      0      1      9
19      0      0      4      0      0      0      0      0      0      0      0      0      0      1      9
12      0      0      4      0      0      0      0      0      0      0      0      0      0      1      9

```

END PRINT-INFO

PWAT-PARM1

```

<PLS > PWATER variable monthly parameter value flags ***
# - # CSNO RTOP UZFG VCS VUZ VNM VIFW VIRC VLE INFC HWT ***
11      0      0      0      0      0      0      0      0      0      0      0      0
17      0      0      0      0      0      0      0      0      0      0      0      0
16      0      0      0      0      0      0      0      0      0      0      0      0
18      0      0      0      0      0      0      0      0      0      0      0      0
19      0      0      0      0      0      0      0      0      0      0      0      0
12      0      0      0      0      0      0      0      0      0      0      0      0

```

END PWAT-PARM1

PWAT-PARM2

```

<PLS > PWATER input info: Part 2 *****
# - # ***FOREST LZSN INFILT LSUR SLSUR KVARY AGWRC
11      0      4.5      0.08      400      0.1      0.5      0.996
17      0      4.5      0.03      400      0.1      0.5      0.996
16      0      4.5      0.03      400      0.05      0.5      0.996
18      0      4.5      0.03      400      0.15      0.5      0.996
19      0      4      2      100      0.001      0.5      0.996
12      0      4.5      0.08      400      0.15      0.5      0.996

```

END PWAT-PARM2

PWAT-PARM3

```

<PLS > PWATER input info: Part 3 *****
# - # ***PETMAX PETMIN INFEXP INFILD DEEPFR BASETP AGWETP
11      0      0      2      2      0      0      0
17      0      0      2      2      0      0      0
16      0      0      2      2      0      0      0
18      0      0      2      2      0      0      0
19      0      0      10      2      0      0      0.7
12      0      0      2      2      0      0      0

```

END PWAT-PARM3

PWAT-PARM4

```

<PLS > PWATER input info: Part 4 *****
# - # CEPSC UZSN NSUR INTFW IRC LZETP ***
11      0.2      0.5      0.35      6      0.5      0.7

```

17	0.1	0.25	0.25	6	0.5	0.25
16	0.1	0.25	0.25	6	0.5	0.25
18	0.1	0.15	0.25	6	0.3	0.25
19	0.2	3	0.5	1	0.7	0.8
12	0.2	0.3	0.35	6	0.3	0.7

END PWAT-PARM4

PWAT-STATE1

```
<PLS > *** Initial conditions at start of simulation
          ran from 1990 to end of 1992 (pat 1-11-95) RUN 21 ***
# - # *** CEPS      SURS      UZS      IFWS      LZS      AGWS      GWVS
11  - 0      0      0      0      2.5      1      0
17  - 0      0      0      0      2.5      1      0
16  - 0      0      0      0      2.5      1      0
18  - 0      0      0      0      2.5      1      0
19  - 0      0      0      0      4.2      1      0
12  - 0      0      0      0      2.5      1      0
```

END PWAT-STATE1

END PERLND

IMPLND

GEN-INFO

```
<PLS ><-----Name-----> Unit-systems Printer ***
# - # User t-series Engl Metr ***
              in out ***
2      ROADS/MOD      1  1  1  27  0
1      ROADS/FLAT    1  1  1  27  0
```

END GEN-INFO

*** Section IWATER***

ACTIVITY

```
<PLS > ***** Active Sections *****
# - # ATMP SNOW IWAT  SLD  IWG IQAL  ***
2      0  0  1  0  0  0
1      0  0  1  0  0  0
```

END ACTIVITY

PRINT-INFO

```
<ILS > ***** Print-flags ***** PIVL  PYR
# - # ATMP SNOW IWAT  SLD  IWG IQAL  *****
2      0  0  4  0  0  0  1  9
1      0  0  4  0  0  0  1  9
```

END PRINT-INFO

IWAT-PARM1

```
<PLS > IWATER variable monthly parameter value flags ***
# - # CSNO RTOP  VRS  VNM RTLI  ***
2      0  0  0  0  0
1      0  0  0  0  0
```

END IWAT-PARM1

IWAT-PARM2

```
<PLS > IWATER input info: Part 2 ***
# - # *** LSUR      SLSUR      NSUR      RETSC
2      400      0.05      0.1      0.08
1      400      0.01      0.1      0.1
```

END IWAT-PARM2

IWAT-PARM3

```
<PLS > IWATER input info: Part 3 ***
# - # ***PETMAX  PETMIN
2      0      0
1      0      0
```

END IWAT-PARM3

IWAT-STATE1

```
<PLS > *** Initial conditions at start of simulation
# - # *** RETS      SURS
2      0      0
```

1 0 0
END IWAT-STATE1

END IMPLND

SCHEMATIC

<-Source-> <Name> #	<--Area--> <-factor-->	<-Target-> <Name> #	MBLK Tbl#	*** ***
Upper Parking -FG***				
PERLND 11	0.89	RCHRES 1	2	
PERLND 17	0.16	RCHRES 1	2	
IMPLND 2	1.87	RCHRES 1	5	
Lower Parking DB FG***				
PERLND 16	0.6	RCHRES 3	2	
PERLND 18	0.41	RCHRES 3	2	
PERLND 11	0.7	RCHRES 3	2	
PERLND 19	0.1	RCHRES 3	2	
PERLND 12	0.52	RCHRES 3	2	
IMPLND 1	0.63	RCHRES 3	5	
IMPLND 2	3.8	RCHRES 3	5	

*****Routing*****

PERLND 11	0.89	COPY 1	12	
PERLND 17	0.16	COPY 1	12	
IMPLND 2	1.87	COPY 1	15	
RCHRES 1	1	RCHRES 2	8	
RCHRES 4	1	RCHRES 5	6	
RCHRES 4		COPY 1	16	
RCHRES 3	1	RCHRES 5	7	
RCHRES 3		COPY 1	17	
RCHRES 3	1	RCHRES 4	8	
RCHRES 2	1	COPY 501	17	
RCHRES 1	1	COPY 501	17	
RCHRES 5	1	COPY 501	16	

END SCHEMATIC

NETWORK

<-Volume-> <Name> #	<-Grp> <Name> #	<-Member-> <Name> #	<--Mult--> <-factor--> #	Tran strg	<-Target <Name> #	vols #	<-Grp> <Name> #	<-Member-> <Name> #	*** ***
COPY 501	OUTPUT	MEAN	1 1	48.4	DISPLY	1	INPUT	TIMSER 1	
GENER 2	OUTPUT	TIMSER		.0011111	RCHRES	1	EXTNL	OUTDGT 1	
GENER 4	OUTPUT	TIMSER		.0011111	RCHRES	3	EXTNL	OUTDGT 1	

<-Volume-> <Name> #	<-Grp> <Name> #	<-Member-> <Name> #	<--Mult--> <-factor--> #	Tran strg	<-Target <Name> #	vols #	<-Grp> <Name> #	<-Member-> <Name> #	*** ***
------------------------	--------------------	------------------------	-----------------------------	--------------	----------------------	-----------	--------------------	------------------------	------------

END NETWORK

RCHRES

GEN-INFO

RCHRES #	Name	Nexits	Unit	Systems	Printer	***	
#	-	#	<----->	<---->	User T-series	Engl Metr LKFG	***
					in out		***
1	Surface TION	PLA-010	3	1	1 1	28 0 1	
2	INFILTRATION	PLA-009	2	1	1 1	28 0 1	
3	Surface Bio-swale	013	3	1	1 1	28 0 1	
4	Bio-swale		1	1	1 1	28 0 1	
5	StormTech	2	1	1	1 1	28 0 1	

END GEN-INFO

*** Section RCHRES***

ACTIVITY

<PLS >	***** Active Sections *****										
# - #	HYFG	ADFG	CNFG	HTFG	SDFG	GQFG	OXFG	NUFG	PKFG	PHFG	***
1	1	0	0	0	0	0	0	0	0	0	
2	1	0	0	0	0	0	0	0	0	0	
3	1	0	0	0	0	0	0	0	0	0	
4	1	0	0	0	0	0	0	0	0	0	
5	1	0	0	0	0	0	0	0	0	0	

END ACTIVITY

PRINT-INFO

<PLS > ***** Print-flags ***** PIVL PYR *****															
#	-	#	HYDR	ADCA	CONS	HEAT	SED	GQL	OXRX	NUTR	PLNK	PHCB	PIVL	PYR	*****
1		4	0	0	0	0	0	0	0	0	0	0	1	9	
2		4	0	0	0	0	0	0	0	0	0	0	1	9	
3		4	0	0	0	0	0	0	0	0	0	0	1	9	
4		4	0	0	0	0	0	0	0	0	0	0	1	9	
5		4	0	0	0	0	0	0	0	0	0	0	1	9	

END PRINT-INFO

HYDR-PARM1

RCHRES Flags for each HYDR Section *****																				
#	-	#	VC	A1	A2	A3	ODFVFG for each possible exit *****				ODGTFG for each possible exit *****				FUNCT for each possible exit *****					
			FG	FG	FG	FG	*	*	*	*	*	*	*	*	*	*	*	*	*	
1		0	1	0	0	4	5	6	0	0	0	1	0	0	0	2	1	2	2	2
2		0	1	0	0	4	5	0	0	0	0	0	0	0	0	2	2	2	2	2
3		0	1	0	0	4	5	6	0	0	0	1	0	0	0	2	1	2	2	2
4		0	1	0	0	4	0	0	0	0	0	0	0	0	0	2	2	2	2	2
5		0	1	0	0	4	0	0	0	0	0	0	0	0	0	2	2	2	2	2

END HYDR-PARM1

HYDR-PARM2

#	-	#	FTABNO	LEN	DELTH	STCOR	KS	DB50	*****
1		1	0.01	0.0	500.0	0.0	0.0	0.0	*****
2		2	0.1	0.0	500.0	0.5	0.0	0.0	*****
3		3	0.01	0.0	0.0	0.0	0.0	0.0	*****
4		4	0.04	0.0	0.0	0.5	0.0	0.0	*****
5		5	0.11	0.0	3.0	0.5	0.0	0.0	*****

END HYDR-PARM2

HYDR-INIT

RCHRES Initial conditions for each HYDR section *****													
#	-	#	VOL	Initial value of COLIND for each possible exit *****					Initial value of OUTDGT for each possible exit *****				
			ac-ft										
1		0	4.0	5.0	6.0	0.0	0.0	0.0	0.0	0.0	0.0	0.0	0.0
2		0	4.0	5.0	0.0	0.0	0.0	0.0	0.0	0.0	0.0	0.0	0.0
3		0	4.0	5.0	6.0	0.0	0.0	0.0	0.0	0.0	0.0	0.0	0.0
4		0	4.0	0.0	0.0	0.0	0.0	0.0	0.0	0.0	0.0	0.0	0.0
5		0	4.0	0.0	0.0	0.0	0.0	0.0	0.0	0.0	0.0	0.0	0.0

END HYDR-INIT

END RCHRES

SPEC-ACTIONS

*** User-Defined Variable Quantity Lines ***																
***	addr															
***	<----->															
***	kwd	varnam	optyp	opn	vari	s1	s2	s3	tp	multiply	lc	ls	ac	as	agfn	***
<****>	<----->	<----->	<->	<----->	<->	<->	<->	<->	<->	<----->	<->	<->	<->	<->	<->	***
UVQUAN	vol2	RCHRES	2	VOL					4							
UVQUAN	v2m2	GLOBAL		WORKSP	1				3							
UVQUAN	vpo2	GLOBAL		WORKSP	2				3							
UVQUAN	v2d2	GENER	2	K	1				3							
***	User-Defined Variable Quantity Lines															
***	addr															
***	<----->															
***	kwd	varnam	optyp	opn	vari	s1	s2	s3	tp	multiply	lc	ls	ac	as	agfn	***
<****>	<----->	<----->	<->	<----->	<->	<->	<->	<->	<->	<----->	<->	<->	<->	<->	<->	***
UVQUAN	vol4	RCHRES	4	VOL					4							
UVQUAN	v2m4	GLOBAL		WORKSP	3				3							
UVQUAN	vpo4	GLOBAL		WORKSP	4				3							
UVQUAN	v2d4	GENER	4	K	1				3							
***	User-Defined Target Variable Names															
***	addr or															
***	<----->															
***	kwd	varnam	ct	vari	s1	s2	s3	frac	oper	vari	s1	s2	s3	frac	oper	***
<****>	<----->	<->	<----->	<->	<->	<->	<->	<----->	<->	<----->	<->	<->	<->	<----->	<->	***

```

UVNAME v2m2 1 WORKSP 1 1.0 QUAN
UVNAME vpo2 1 WORKSP 2 1.0 QUAN
UVNAME v2d2 1 K 1 1.0 QUAN
*** User-Defined Target Variable Names
*** addr or addr or
*** <-----> <----->
*** kwd varnam ct vari s1 s2 s3 frac oper vari s1 s2 s3 frac oper
<****> <-----<-> <-----<-><-> <-----<-> <-----<-> <-----<->
UVNAME v2m4 1 WORKSP 3 1.0 QUAN
UVNAME vpo4 1 WORKSP 4 1.0 QUAN
UVNAME v2d4 1 K 1 1.0 QUAN
*** opt foplop dcdts yr mo dy hr mn d t vnam s1 s2 s3 ac quantity tc ts rp
<****><-><-><-><-><-> <> <> <> <><><> <-----<-><-><-><-> <> <-><->
GENER 2 v2m2 = 2750.71
*** Compute remaining available pore space
GENER 2 vpo2 = v2m2
GENER 2 vpo2 -= vol2
*** Check to see if VPORA goes negative; if so set VPORA = 0.0
IF (vpo2 < 0.0) THEN
GENER 2 vpo2 = 0.0
END IF
*** Infiltration volume
GENER 2 v2d2 = vpo2
*** opt foplop dcdts yr mo dy hr mn d t vnam s1 s2 s3 ac quantity tc ts rp
<****><-><-><-><-><-> <> <> <> <><><> <-----<-><-><-><-> <> <-><->
GENER 4 v2m4 = 3610.2
*** Compute remaining available pore space
GENER 4 vpo4 = v2m4
GENER 4 vpo4 -= vol4
*** Check to see if VPORA goes negative; if so set VPORA = 0.0
IF (vpo4 < 0.0) THEN
GENER 4 vpo4 = 0.0
END IF
*** Infiltration volume
GENER 4 v2d4 = vpo4
END SPEC-ACTIONS
FTABLES
FTABLE 2
53 5
Depth Area Volume Outflow1 Outflow2 Velocity Travel Time***
(ft) (acres) (acre-ft) (cfs) (cfs) (ft/sec) (Minutes)***
0.000000 0.126263 0.000000 0.000000 0.000000
0.038462 0.126263 0.002221 0.000000 0.000000
0.076923 0.126263 0.004442 0.000000 0.000000
0.115385 0.126263 0.006662 0.000000 0.000000
0.153846 0.126263 0.008883 0.000000 0.001242
0.192308 0.126263 0.011104 0.000000 0.002990
0.230769 0.126263 0.013325 0.000000 0.005775
0.269231 0.126263 0.015545 0.000000 0.009761
0.307692 0.126263 0.017766 0.000000 0.015091
0.346154 0.126263 0.019987 0.000000 0.021893
0.384615 0.126263 0.022208 0.000000 0.030287
0.423077 0.126263 0.024428 0.000000 0.040382
0.461538 0.126263 0.026649 0.000000 0.052283
0.500000 0.126263 0.028870 0.000000 0.066088
0.538462 0.126263 0.031091 0.000000 0.081888
0.576923 0.126263 0.033311 0.000000 0.099774
0.615385 0.126263 0.035532 0.000000 0.119830
0.653846 0.126263 0.037753 0.000000 0.142138
0.692308 0.126263 0.039974 0.000000 0.166778
0.730769 0.126263 0.042195 0.000000 0.193825
0.769231 0.126263 0.044415 0.000000 0.223354
0.807692 0.126263 0.046636 0.000000 0.255436
0.846154 0.126263 0.048857 0.000000 0.290142
0.884615 0.126263 0.051078 0.000000 0.327540
0.923077 0.126263 0.053298 0.000000 0.367694
0.961538 0.126263 0.055519 0.000000 0.369213
1.000000 0.126263 0.057740 0.000000 0.369213
1.038462 0.126263 0.059961 0.000000 0.369213
1.076923 0.126263 0.062181 0.000000 0.369213

```

1.115385	0.126263	0.064402	0.000000	0.369213
1.153846	0.126263	0.066623	0.000000	0.369213
1.192308	0.126263	0.068844	0.000000	0.369213
1.230769	0.126263	0.071064	0.000000	0.369213
1.269231	0.126263	0.073285	0.000000	0.369213
1.307692	0.126263	0.075506	0.000000	0.369213
1.346154	0.126263	0.077727	0.000000	0.369213
1.384615	0.126263	0.079948	0.000000	0.369213
1.423077	0.126263	0.082168	0.000000	0.369213
1.461538	0.126263	0.084389	0.000000	0.369213
1.500000	0.126263	0.086404	0.000000	0.369213
1.538462	0.126263	0.088420	0.000000	0.369213
1.576923	0.126263	0.090435	0.000000	0.369213
1.615385	0.126263	0.092450	0.000000	0.369213
1.653846	0.126263	0.094466	0.000000	0.369213
1.692308	0.126263	0.096481	0.000000	0.369213
1.730769	0.126263	0.098497	0.000000	0.369213
1.769231	0.126263	0.100512	0.000000	0.369213
1.807692	0.126263	0.102527	0.000000	0.369213
1.846154	0.126263	0.104543	0.000000	0.369213
1.884615	0.126263	0.106558	0.000000	0.369213
1.923077	0.126263	0.108573	0.000000	0.369213
1.961538	0.126263	0.110589	0.000000	0.369213
2.000000	0.126263	0.120232	0.000000	0.369213

END FTABLE 2
 FTABLE 1

Time*** (Minutes)***	Depth (ft)	Area (acres)	Volume (acre-ft)	Outflow1 (cfs)	Outflow2 (cfs)	outflow 3 (cfs)	Velocity (ft/sec)	Travel
0.000000	0.126263	0.000000	0.000000	0.000000	0.000000	0.000000		
0.038462	0.126263	0.004856	0.000000	0.000000	1.527779	0.000000		
0.076923	0.126263	0.009713	0.000000	0.000000	1.606127	0.000000		
0.115385	0.126263	0.014569	0.000000	0.000000	1.645300	0.000000		
0.153846	0.126263	0.019425	0.000000	0.000000	1.684474	0.000000		
0.192308	0.126263	0.024281	0.000000	0.000000	1.723648	0.000000		
0.230769	0.126263	0.029138	0.000000	0.000000	1.762822	0.000000		
0.269231	0.126263	0.033994	0.000000	0.000000	1.801996	0.000000		
0.307692	0.126263	0.038850	0.000000	0.000000	1.841170	0.000000		
0.346154	0.126263	0.043706	0.000000	0.000000	1.880343	0.000000		
0.384615	0.126263	0.048563	0.000000	0.000000	1.919517	0.000000		
0.423077	0.126263	0.053419	0.000000	0.000000	1.958691	0.000000		
0.461538	0.126263	0.058275	0.000000	0.000000	1.997865	0.000000		
0.500000	0.126263	0.063131	0.000000	0.000000	2.037039	0.000000		
0.538462	0.126263	0.067988	0.000000	0.000000	2.076212	0.000000		
0.576923	0.126263	0.072844	0.000000	0.000000	2.115386	0.000000		
0.615385	0.126263	0.077700	0.000000	0.000000	2.154560	0.000000		
0.653846	0.126263	0.082556	0.000000	0.000000	2.193734	0.000000		
0.692308	0.126263	0.087413	0.000000	0.000000	2.232908	0.000000		
0.730769	0.126263	0.092269	0.000000	0.000000	2.272082	0.000000		
0.769231	0.126263	0.097125	0.000000	0.000000	2.311255	0.000000		
0.807692	0.126263	0.101981	0.000000	0.000000	2.350429	0.000000		
0.846154	0.126263	0.106838	0.000000	0.000000	2.389603	0.000000		
0.884615	0.126263	0.111694	0.000000	0.000000	2.428777	0.000000		
0.923077	0.126263	0.116550	0.000000	0.000000	2.467951	0.000000		
0.961538	0.126263	0.121406	0.000000	0.000000	2.507125	0.000000		
1.000000	0.126263	0.126263	0.000000	0.000000	2.546298	0.000000		
1.038462	0.126263	0.131119	0.053269	2.585472	0.000000			
1.076923	0.126263	0.135975	0.149573	2.624646	0.000000			
1.115385	0.126263	0.140831	0.269306	2.663820	0.000000			
1.153846	0.126263	0.145688	0.398865	2.702994	0.000000			
1.192308	0.126263	0.150544	0.524396	2.742167	0.000000			
1.230769	0.126263	0.155400	0.633045	2.781341	0.000000			
1.269231	0.126263	0.160256	0.715919	2.820515	0.000000			
1.307692	0.126263	0.165113	0.772013	2.859689	0.000000			
1.346154	0.126263	0.169969	0.823591	2.898863	0.000000			
1.384615	0.126263	0.174825	0.868141	2.938037	0.000000			
1.423077	0.126263	0.179681	0.910514	2.977210	0.000000			
1.461538	0.126263	0.184538	0.951001	3.016384	0.000000			

1.500000 0.126263 0.189394 0.989833 3.055558 0.000000
 1.500000 0.126263 0.189394 1.027198 3.055558 0.000000

END FTABLE 1
 FTABLE 4

58	4	Depth (ft)	Area (acres)	Volume (acre-ft)	Outflow1 (cfs)	Velocity (ft/sec)	Travel Time*** (Minutes)***
		0.000000	0.155303	0.000000	0.000000		
		0.043956	0.154043	0.000795	0.000000		
		0.087912	0.152607	0.001604	0.000000		
		0.131868	0.151173	0.002424	0.000263		
		0.175824	0.149743	0.003258	0.001024		
		0.219780	0.148316	0.004104	0.002516		
		0.263736	0.146892	0.004964	0.004910		
		0.307692	0.145472	0.005836	0.008347		
		0.351648	0.144054	0.006721	0.012950		
		0.395604	0.142640	0.007618	0.018833		
		0.439560	0.141229	0.008529	0.026098		
		0.483516	0.139821	0.009453	0.034840		
		0.527473	0.138417	0.010390	0.045150		
		0.571429	0.137015	0.011340	0.057113		
		0.615385	0.135617	0.012302	0.070808		
		0.659341	0.134222	0.013278	0.086315		
		0.703297	0.132830	0.014268	0.103705		
		0.747253	0.131441	0.015270	0.110647		
		0.791209	0.130056	0.016285	0.144421		
		0.835165	0.128673	0.017314	0.155886		
		0.879121	0.127294	0.018356	0.180416		
		0.923077	0.125918	0.019411	0.181976		
		0.967033	0.124546	0.020480	0.231848		
		1.010989	0.123176	0.021562	0.251436		
		1.054945	0.121810	0.022657	0.267363		
		1.098901	0.120447	0.023766	0.272458		
		1.142857	0.119087	0.024889	0.307573		
		1.186813	0.117730	0.026024	0.338946		
		1.230769	0.116376	0.027174	0.367563		
		1.274725	0.115026	0.028337	0.394042		
		1.318681	0.113679	0.029513	0.416646		
		1.362637	0.112335	0.030703	0.418801		
		1.406593	0.110994	0.031907	0.442138		
		1.450549	0.109656	0.033124	0.464273		
		1.494505	0.108322	0.034355	0.485376		
		1.538462	0.106991	0.035485	0.505579		
		1.582418	0.105663	0.036627	0.524990		
		1.626374	0.104338	0.037782	0.543695		
		1.670330	0.103016	0.038949	0.561768		
		1.714286	0.101698	0.040129	0.579269		
		1.758242	0.100383	0.041322	0.596250		
		1.802198	0.099071	0.042527	0.612755		
		1.846154	0.097762	0.043745	0.628824		
		1.890110	0.096456	0.044975	0.644489		
		1.934066	0.095154	0.046219	0.659782		
		1.978022	0.093854	0.047475	0.674727		
		2.021978	0.092558	0.048744	0.689348		
		2.065934	0.091266	0.050025	0.703668		
		2.109890	0.089976	0.051320	0.717704		
		2.153846	0.088689	0.052627	0.741637		
		2.197802	0.087406	0.053948	0.768097		
		2.241758	0.086126	0.055281	0.793709		
		2.285714	0.084849	0.056627	0.818572		
		2.329670	0.083575	0.057987	0.842781		
		2.373626	0.082305	0.059359	0.866450		
		2.417582	0.081037	0.060744	0.889769		
		2.461538	0.079773	0.062143	0.913487		
		2.500000	0.078512	0.082879	0.943875		

END FTABLE 4
 FTABLE 3

36	6	Depth	Area	Volume	Outflow1	Outflow2	outflow 3	Velocity	Travel Time***
----	---	-------	------	--------	----------	----------	-----------	----------	----------------

(Minutes)***	(ft)	(acres)	(acre-ft)	(cfs)	(cfs)	(cfs)	(ft/sec)
0.000000	0.078512	0.000000	0.000000	0.000000	0.000000	0.000000	
0.043956	0.156746	0.006858	0.000000	0.000000	0.950001	0.000000	
0.087912	0.158191	0.013780	0.000000	0.000000	1.005678	0.000000	
0.131868	0.159640	0.020765	0.000000	0.000000	1.033517	0.000000	
0.175824	0.161093	0.027814	0.000000	0.000000	1.061356	0.000000	
0.219780	0.162548	0.034927	0.000000	0.000000	1.089195	0.000000	
0.263736	0.164006	0.042104	0.000000	0.000000	1.117034	0.000000	
0.307692	0.165468	0.049345	0.000000	0.000000	1.144873	0.000000	
0.351648	0.166933	0.056651	0.000000	0.000000	1.172712	0.000000	
0.395604	0.168401	0.064021	0.000000	0.000000	1.200550	0.000000	
0.439560	0.169873	0.071456	0.000000	0.000000	1.228389	0.000000	
0.483516	0.171347	0.078955	0.000000	0.000000	1.256228	0.000000	
0.527473	0.172825	0.086519	0.000000	0.000000	1.284067	0.000000	
0.571429	0.174306	0.094148	0.000000	0.000000	1.311906	0.000000	
0.615385	0.175790	0.101843	0.000000	0.000000	1.339745	0.000000	
0.659341	0.177277	0.109602	0.000000	0.000000	1.367584	0.000000	
0.703297	0.178768	0.117428	0.000000	0.000000	1.395422	0.000000	
0.747253	0.180261	0.125318	0.000000	0.000000	1.423261	0.000000	
0.791209	0.181758	0.133275	0.000000	0.000000	1.451100	0.000000	
0.835165	0.183258	0.141297	0.000000	0.000000	1.478939	0.000000	
0.879121	0.184761	0.149386	0.000000	0.000000	1.506778	0.000000	
0.923077	0.186268	0.157540	0.000000	0.000000	1.534617	0.000000	
0.967033	0.187778	0.165761	0.000000	0.000000	1.562455	0.000000	
1.010989	0.189290	0.174048	0.012228	0.012228	1.590294	0.000000	
1.054945	0.190806	0.182402	0.136453	0.136453	1.618133	0.000000	
1.098901	0.192326	0.190822	0.328096	0.328096	1.645972	0.000000	
1.142857	0.193848	0.199310	0.563536	0.563536	1.673811	0.000000	
1.186813	0.195374	0.207864	0.826090	0.826090	1.701650	0.000000	
1.230769	0.196902	0.216485	1.099144	1.099144	1.729489	0.000000	
1.274725	0.198434	0.225174	1.365707	1.365707	1.757327	0.000000	
1.318681	0.199970	0.233930	1.609623	1.609623	1.785166	0.000000	
1.362637	0.201508	0.242754	1.817597	1.817597	1.813005	0.000000	
1.406593	0.203050	0.251645	1.981777	1.981777	1.840844	0.000000	
1.450549	0.204594	0.260604	2.102770	2.102770	1.868683	0.000000	
1.494505	0.206142	0.269632	2.193018	2.193018	1.896522	0.000000	
1.500000	0.206336	0.270765	2.311197	2.311197	1.900002	0.000000	

END FTABLE 3

FTABLE 5

69 4

Depth (ft)	Area (acres)	Volume (acre-ft)	Outflow (cfs)	Velocity (ft/sec)	Travel Time*** (Minutes)***
0.000000	0.304940	0.000000	0.000000		
0.083333	0.304940	0.010164	0.026811		
0.166667	0.304940	0.020328	0.037916		
0.250000	0.304940	0.030493	0.046438		
0.333333	0.304940	0.040658	0.053622		
0.416667	0.304940	0.050822	0.059951		
0.500000	0.304940	0.060987	0.065673		
0.583333	0.304940	0.071151	0.070935		
0.666667	0.304940	0.081315	0.075833		
0.750000	0.304940	0.091480	0.080433		
0.833333	0.304940	0.101644	0.084784		
0.916667	0.304940	0.111809	0.088922		
1.000000	0.304940	0.121973	0.092876		
1.083333	0.304940	0.144566	0.096668		
1.166667	0.304940	0.167054	0.100317		
1.250000	0.304940	0.189472	0.103838		
1.333333	0.304940	0.211817	0.107244		
1.416667	0.304940	0.234080	0.110544		
1.500000	0.304940	0.256263	0.113749		
1.583333	0.304940	0.278368	0.116866		
1.666667	0.304940	0.300379	0.119902		
1.750000	0.304940	0.322300	0.122863		
1.833333	0.304940	0.344121	0.125754		
1.916667	0.304940	0.365841	0.128581		
2.000000	0.304940	0.387451	0.131346		
2.083333	0.304940	0.408950	0.134055		
2.166667	0.304940	0.430328	0.136709		

2.250000	0.304940	0.451581	0.139314
2.333333	0.304940	0.472705	0.190831
2.416667	0.304940	0.493683	0.213622
2.500000	0.304940	0.514517	0.231652
2.583333	0.304940	0.535199	0.247198
2.666667	0.304940	0.555718	0.261145
2.750000	0.304940	0.576064	0.273946
2.833333	0.304940	0.596230	0.317206
2.916667	0.304940	0.616207	0.341412
3.000000	0.304940	0.635983	0.362021
3.083333	0.304940	0.655547	0.380582
3.166667	0.304940	0.674895	0.397725
3.250000	0.304940	0.694011	0.413794
3.333333	0.304940	0.712881	0.429002
3.416667	0.304940	0.731479	0.443496
3.500000	0.304940	0.749809	0.457383
3.583333	0.304940	0.767847	0.470744
3.666667	0.304940	0.785567	0.483640
3.750000	0.304940	0.802946	0.496123
3.833333	0.304940	0.819968	0.508235
3.916667	0.304940	0.836602	0.520010
4.000000	0.304940	0.852806	0.531477
4.083333	0.304940	0.868528	0.542662
4.166667	0.304940	0.883724	0.553586
4.250000	0.304940	0.898308	0.564269
4.333333	0.304940	0.912107	0.574726
4.416667	0.304940	0.924703	0.619232
4.500000	0.304940	0.936296	1.097199
4.583333	0.304940	0.947502	1.841192
4.666667	0.304940	0.958353	2.738396
4.750000	0.304940	0.968730	3.696772
4.833333	0.304940	0.978997	4.622288
4.916667	0.304940	0.989160	5.428016
5.000000	0.304940	0.999326	6.052976
5.083333	0.304940	1.009490	6.486821
5.166667	0.304940	1.019655	6.874559
5.250000	0.304940	1.029819	7.211782
5.333333	0.304940	1.039983	7.533140
5.416667	0.304940	1.050148	7.840707
5.500000	0.304940	1.060312	8.136137
5.583333	0.304940	1.070477	8.420781
5.666667	0.304940	1.080641	8.695751

END FTABLE 5

END FTABLES

EXT SOURCES

<-Volume->	<Member>	SsysSgap<--Mult-->	Tran	<-Target vols>	<-Grp>	<-Member->	***			
<Name>	#	<Name>	#	tem	strg<-factor->	strg	<Name>	#	#	***
WDM	2	PREC	ENGL	1		PERLND	1	999	EXTNL	PREC
WDM	2	PREC	ENGL	1		IMPLND	1	999	EXTNL	PREC
WDM	1	EVAP	ENGL	1		PERLND	1	999	EXTNL	PETINP
WDM	1	EVAP	ENGL	1		IMPLND	1	999	EXTNL	PETINP
WDM	2	PREC	ENGL	1		RCHRES	1		EXTNL	PREC
WDM	2	PREC	ENGL	1		RCHRES	3		EXTNL	PREC
WDM	1	EVAP	ENGL	0.5		RCHRES	1		EXTNL	POTEV
WDM	1	EVAP	ENGL	1		RCHRES	2		EXTNL	POTEV
WDM	1	EVAP	ENGL	0.5		RCHRES	3		EXTNL	POTEV
WDM	1	EVAP	ENGL	1		RCHRES	4		EXTNL	POTEV

END EXT SOURCES

EXT TARGETS

<-Volume->	<-Grp>	<-Member->	<--Mult-->	Tran	<-Volume->	<Member>	Tsys	Tgap	Amd	***	
<Name>	#	<Name>	#	#<-factor->	strg	<Name>	#	<Name>	tem	strg	strg***
RCHRES	2	HYDR	RO	1	1	1	WDM	1002	FLOW	ENGL	REPL
RCHRES	2	HYDR	O	1	1	1	WDM	1003	FLOW	ENGL	REPL
RCHRES	2	HYDR	O	2	1	1	WDM	1004	FLOW	ENGL	REPL
RCHRES	2	HYDR	STAGE	1	1	1	WDM	1005	STAG	ENGL	REPL
RCHRES	1	HYDR	STAGE	1	1	1	WDM	1006	STAG	ENGL	REPL
RCHRES	1	HYDR	O	1	1	1	WDM	1007	FLOW	ENGL	REPL

```

COPY      1 OUTPUT MEAN   1 1      48.4      WDM      701 FLOW      ENGL      REPL
COPY     501 OUTPUT MEAN   1 1      48.4      WDM      801 FLOW      ENGL      REPL
RCHRES    5 HYDR   RO     1 1        1      WDM     1000 FLOW      ENGL      REPL
RCHRES    5 HYDR   STAGE  1 1        1      WDM     1001 STAG      ENGL      REPL
END EXT TARGETS

```

MASS-LINK

```

<Volume>  <-Grp> <-Member-><--Mult--> <Target> <-Grp> <-Member->***
<Name>    <Name> # #<-factor--> <Name> <Name> # #***
  MASS-LINK      2
PERLND    PWATER SURO      0.083333  RCHRES    INFLOW IVOL
  END MASS-LINK      2

  MASS-LINK      5
IMPLND    IWATER SURO      0.083333  RCHRES    INFLOW IVOL
  END MASS-LINK      5

  MASS-LINK      6
RCHRES    ROFLOW          RCHRES    INFLOW
  END MASS-LINK      6

  MASS-LINK      7
RCHRES    OFLOW  OVOL    1      RCHRES    INFLOW IVOL
  END MASS-LINK      7

  MASS-LINK      8
RCHRES    OFLOW  OVOL    2      RCHRES    INFLOW IVOL
  END MASS-LINK      8

  MASS-LINK     12
PERLND    PWATER SURO      0.083333  COPY      INPUT  MEAN
  END MASS-LINK     12

  MASS-LINK     15
IMPLND    IWATER SURO      0.083333  COPY      INPUT  MEAN
  END MASS-LINK     15

  MASS-LINK     16
RCHRES    ROFLOW          COPY      INPUT  MEAN
  END MASS-LINK     16

  MASS-LINK     17
RCHRES    OFLOW  OVOL    1      COPY      INPUT  MEAN
  END MASS-LINK     17

```

END MASS-LINK

END RUN

Predeveloped HSPF Message File

Mitigated HSPF Message File

Disclaimer

Legal Notice

This program and accompanying documentation are provided 'as-is' without warranty of any kind. The entire risk regarding the performance and results of this program is assumed by End User. Clear Creek Solutions Inc. and the governmental licensee or sublicensees disclaim all warranties, either expressed or implied, including but not limited to implied warranties of program and accompanying documentation. In no event shall Clear Creek Solutions Inc. be liable for any damages whatsoever (including without limitation to damages for loss of business profits, loss of business information, business interruption, and the like) arising out of the use of, or inability to use this program even if Clear Creek Solutions Inc. or their authorized representatives have been advised of the possibility of such damages. Software Copyright © by : Clear Creek Solutions, Inc. 2005-2022; All Rights Reserved.

Clear Creek Solutions, Inc.
6200 Capitol Blvd. Ste F
Olympia, WA. 98501
Toll Free 1(866)943-0304
Local (360)943-0304

www.clearcreeksolutions.com

WWHM2012
PROJECT REPORT

WETLAND F
MR 8: WETLANDS PROTECTION ANALYSIS

General Model Information

Project Name: SHBTC-Wetland Analysis

Site Name:

Site Address:

City: Puyallup

Report Date: 2/10/2022

Gage:

Data Start: 10/01/1901

Data End: 09/30/2059

Timestep: 15 Minute

Precip Scale: 1.000

Version Date: 2018/10/10

Version: 4.2.16

Provide Gage Information [Storm Report; Pg 297 of 347]



POC Thresholds

Low Flow Threshold for POC1: 50 Percent of the 2 Year

High Flow Threshold for POC1: 50 Year

Landuse Basin Data

Predeveloped Land Use

DB - A EG - Wetland

Bypass:	No
GroundWater:	No
Pervious Land Use	acre
C, Forest, Mod	0.66
C, Forest, Steep	0.55
Pervious Total	1.21
Impervious Land Use	acre
Impervious Total	0
Basin Total	1.21

Element Flows To:
Surface Interflow Groundwater

Mitigated Land Use

DB - A -FG Wetland

Bypass: No

GroundWater: No

Pervious Land Use acre
C, Lawn, Mod 0.15
C, Forest, Steep 0.45
C, Forest, Mod 0.45

Pervious Total 1.05

Impervious Land Use acre

Impervious Total 0

Basin Total 1.05

Based on the Basin Map, Figure 2, it is unclear what changed in the post-developed condition that implies 0.15ac of lawn tributary to the wetland. Show on the Basin Map where this applies for Wetland F (see Basin Map Comments also) [Storm Report; Pg 299 of 347]

Element Flows To:
Surface Interflow Groundwater

Routing Elements
Predeveloped Routing

Mitigated Routing

Analysis Results

POC 1

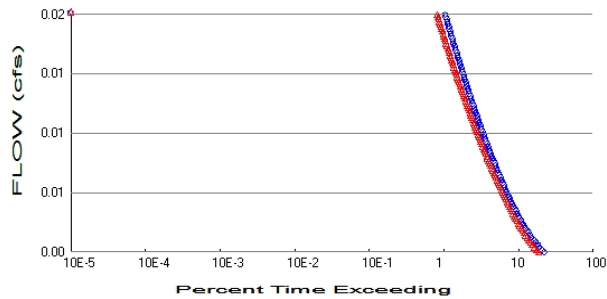
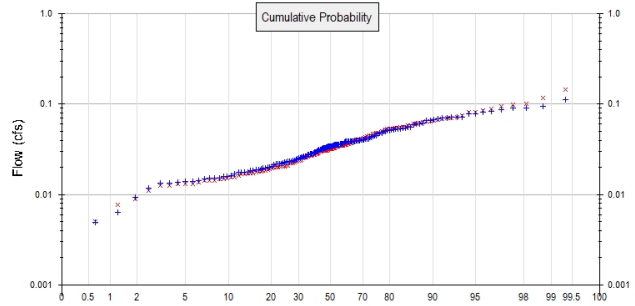
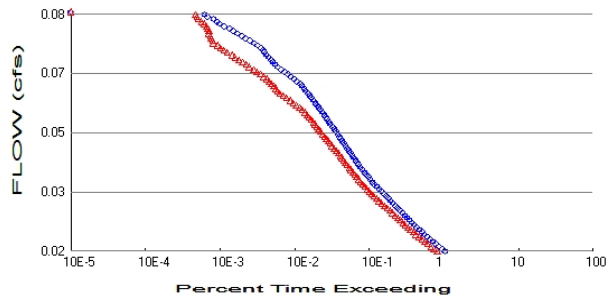

+ Predeveloped x Mitigated

Predeveloped Landuse Totals for POC #1

Total Pervious Area: 1.21
 Total Impervious Area: 0

Mitigated Landuse Totals for POC #1

Total Pervious Area: 1.05
 Total Impervious Area: 0

Flow Frequency Method: Log Pearson Type III 17B

Flow Frequency Return Periods for Predeveloped. POC #1

Return Period	Flow(cfs)
2 year	0.033889
5 year	0.051962
10 year	0.063058
25 year	0.075875
50 year	0.084556
100 year	0.09254

Flow Frequency Return Periods for Mitigated. POC #1

Return Period	Flow(cfs)
2 year	0.032369
5 year	0.05192
10 year	0.065403
25 year	0.08267
50 year	0.095564
100 year	0.108412

Annual Peaks

Annual Peaks for Predeveloped and Mitigated. POC #1

Year	Predeveloped	Mitigated
1902	0.026	0.023
1903	0.022	0.020
1904	0.040	0.061
1905	0.018	0.017
1906	0.009	0.009
1907	0.052	0.047
1908	0.039	0.034
1909	0.039	0.034
1910	0.053	0.054
1911	0.034	0.031
1912	0.113	0.143
1913	0.051	0.045
1914	0.014	0.045
1915	0.022	0.020
1916	0.034	0.030
1917	0.014	0.013
1918	0.036	0.032
1919	0.026	0.024
1920	0.034	0.031
1921	0.040	0.035
1922	0.040	0.043
1923	0.033	0.029
1924	0.016	0.015
1925	0.020	0.018
1926	0.034	0.033
1927	0.023	0.021
1928	0.028	0.026
1929	0.056	0.055
1930	0.036	0.032
1931	0.033	0.030
1932	0.028	0.026
1933	0.025	0.026
1934	0.070	0.068
1935	0.035	0.031
1936	0.029	0.026
1937	0.048	0.054
1938	0.029	0.027
1939	0.003	0.004
1940	0.030	0.027
1941	0.018	0.016
1942	0.044	0.041
1943	0.024	0.022
1944	0.051	0.062
1945	0.039	0.035
1946	0.023	0.028
1947	0.015	0.014
1948	0.071	0.063
1949	0.060	0.055
1950	0.020	0.019
1951	0.023	0.021
1952	0.094	0.099
1953	0.082	0.088
1954	0.033	0.030
1955	0.026	0.024
1956	0.013	0.013
1957	0.041	0.037

1958	0.083	0.081
1959	0.053	0.056
1960	0.017	0.015
1961	0.055	0.057
1962	0.032	0.029
1963	0.016	0.015
1964	0.018	0.041
1965	0.062	0.056
1966	0.019	0.018
1967	0.028	0.035
1968	0.028	0.027
1969	0.030	0.027
1970	0.044	0.041
1971	0.067	0.058
1972	0.045	0.070
1973	0.053	0.053
1974	0.034	0.041
1975	0.072	0.082
1976	0.038	0.050
1977	0.014	0.013
1978	0.066	0.065
1979	0.019	0.017
1980	0.035	0.033
1981	0.035	0.032
1982	0.015	0.014
1983	0.054	0.048
1984	0.030	0.028
1985	0.036	0.044
1986	0.034	0.031
1987	0.061	0.065
1988	0.042	0.036
1989	0.037	0.033
1990	0.040	0.036
1991	0.034	0.031
1992	0.048	0.042
1993	0.045	0.040
1994	0.068	0.060
1995	0.015	0.014
1996	0.069	0.068
1997	0.031	0.028
1998	0.036	0.040
1999	0.006	0.008
2000	0.024	0.022
2001	0.016	0.015
2002	0.050	0.072
2003	0.039	0.036
2004	0.040	0.038
2005	0.071	0.094
2006	0.023	0.020
2007	0.021	0.019
2008	0.036	0.032
2009	0.025	0.023
2010	0.022	0.020
2011	0.019	0.017
2012	0.033	0.032
2013	0.020	0.018
2014	0.015	0.014
2015	0.031	0.053

2016	0.013	0.013
2017	0.052	0.048
2018	0.088	0.086
2019	0.090	0.101
2020	0.031	0.037
2021	0.047	0.042
2022	0.020	0.018
2023	0.039	0.035
2024	0.091	0.118
2025	0.036	0.032
2026	0.055	0.050
2027	0.022	0.020
2028	0.019	0.018
2029	0.040	0.035
2030	0.072	0.065
2031	0.025	0.022
2032	0.014	0.013
2033	0.022	0.020
2034	0.023	0.020
2035	0.078	0.070
2036	0.042	0.039
2037	0.012	0.011
2038	0.039	0.048
2039	0.005	0.005
2040	0.018	0.017
2041	0.026	0.024
2042	0.079	0.076
2043	0.038	0.035
2044	0.050	0.044
2045	0.035	0.031
2046	0.038	0.034
2047	0.031	0.028
2048	0.039	0.035
2049	0.036	0.034
2050	0.027	0.025
2051	0.039	0.047
2052	0.023	0.020
2053	0.039	0.035
2054	0.043	0.052
2055	0.018	0.017
2056	0.018	0.016
2057	0.026	0.024
2058	0.033	0.030
2059	0.059	0.054

Ranked Annual Peaks

Ranked Annual Peaks for Predeveloped and Mitigated. POC #1

Rank	Predeveloped	Mitigated
1	0.1134	0.1434
2	0.0939	0.1177
3	0.0906	0.1011
4	0.0904	0.0986
5	0.0875	0.0937
6	0.0835	0.0883
7	0.0816	0.0855
8	0.0788	0.0818
9	0.0781	0.0809
10	0.0719	0.0756

11	0.0716	0.0721
12	0.0711	0.0703
13	0.0707	0.0698
14	0.0697	0.0682
15	0.0691	0.0681
16	0.0679	0.0653
17	0.0666	0.0650
18	0.0660	0.0645
19	0.0618	0.0626
20	0.0607	0.0617
21	0.0602	0.0607
22	0.0591	0.0603
23	0.0562	0.0584
24	0.0554	0.0575
25	0.0550	0.0559
26	0.0544	0.0556
27	0.0533	0.0554
28	0.0533	0.0549
29	0.0528	0.0542
30	0.0521	0.0538
31	0.0520	0.0535
32	0.0509	0.0533
33	0.0508	0.0532
34	0.0499	0.0525
35	0.0499	0.0500
36	0.0484	0.0496
37	0.0484	0.0484
38	0.0469	0.0484
39	0.0449	0.0475
40	0.0445	0.0474
41	0.0443	0.0469
42	0.0435	0.0453
43	0.0432	0.0446
44	0.0416	0.0442
45	0.0415	0.0438
46	0.0414	0.0428
47	0.0404	0.0420
48	0.0401	0.0417
49	0.0400	0.0414
50	0.0398	0.0407
51	0.0396	0.0406
52	0.0395	0.0406
53	0.0395	0.0402
54	0.0392	0.0398
55	0.0391	0.0391
56	0.0389	0.0384
57	0.0388	0.0370
58	0.0387	0.0368
59	0.0387	0.0365
60	0.0386	0.0365
61	0.0386	0.0356
62	0.0384	0.0354
63	0.0378	0.0353
64	0.0377	0.0352
65	0.0366	0.0352
66	0.0364	0.0351
67	0.0363	0.0351
68	0.0361	0.0350

69	0.0357	0.0348
70	0.0356	0.0344
71	0.0356	0.0341
72	0.0355	0.0338
73	0.0354	0.0338
74	0.0352	0.0330
75	0.0352	0.0330
76	0.0349	0.0330
77	0.0342	0.0323
78	0.0342	0.0322
79	0.0341	0.0322
80	0.0339	0.0320
81	0.0338	0.0317
82	0.0338	0.0316
83	0.0337	0.0310
84	0.0331	0.0310
85	0.0330	0.0309
86	0.0328	0.0308
87	0.0327	0.0308
88	0.0326	0.0307
89	0.0318	0.0305
90	0.0314	0.0300
91	0.0312	0.0298
92	0.0310	0.0297
93	0.0307	0.0290
94	0.0300	0.0288
95	0.0298	0.0283
96	0.0295	0.0281
97	0.0293	0.0276
98	0.0289	0.0275
99	0.0282	0.0274
100	0.0281	0.0273
101	0.0281	0.0272
102	0.0275	0.0268
103	0.0273	0.0261
104	0.0263	0.0261
105	0.0262	0.0258
106	0.0261	0.0258
107	0.0261	0.0251
108	0.0260	0.0241
109	0.0254	0.0237
110	0.0253	0.0237
111	0.0249	0.0236
112	0.0243	0.0231
113	0.0239	0.0229
114	0.0235	0.0225
115	0.0234	0.0224
116	0.0233	0.0224
117	0.0231	0.0210
118	0.0228	0.0208
119	0.0227	0.0205
120	0.0221	0.0203
121	0.0219	0.0203
122	0.0219	0.0203
123	0.0218	0.0202
124	0.0216	0.0201
125	0.0215	0.0200
126	0.0203	0.0198

127	0.0201	0.0193
128	0.0198	0.0187
129	0.0195	0.0185
130	0.0194	0.0183
131	0.0191	0.0181
132	0.0189	0.0179
133	0.0189	0.0178
134	0.0183	0.0173
135	0.0182	0.0172
136	0.0177	0.0172
137	0.0177	0.0170
138	0.0175	0.0168
139	0.0175	0.0163
140	0.0168	0.0156
141	0.0161	0.0155
142	0.0160	0.0152
143	0.0159	0.0150
144	0.0153	0.0150
145	0.0153	0.0142
146	0.0152	0.0141
147	0.0149	0.0141
148	0.0144	0.0137
149	0.0141	0.0132
150	0.0140	0.0130
151	0.0137	0.0130
152	0.0134	0.0126
153	0.0133	0.0125
154	0.0118	0.0110
155	0.0094	0.0089
156	0.0064	0.0076
157	0.0049	0.0051
158	0.0033	0.0042

LID Duration Flows

The Facility PASSED

Flow(cfs)	Predev	Mit	Percentage	Pass/Fail
0.0027	1228232	1028790	83	Pass
0.0029	1146239	961755	83	Pass
0.0030	1070894	903030	84	Pass
0.0031	1002752	850400	84	Pass
0.0033	942365	802755	85	Pass
0.0034	888072	761205	85	Pass
0.0036	839320	723532	86	Pass
0.0037	794999	689184	86	Pass
0.0039	754557	657606	87	Pass
0.0040	717992	628797	87	Pass
0.0041	685306	601651	87	Pass
0.0043	655390	575613	87	Pass
0.0044	627689	551680	87	Pass
0.0046	601097	529021	88	Pass
0.0047	576721	507968	88	Pass
0.0049	553619	488190	88	Pass
0.0050	531680	469077	88	Pass
0.0052	511459	451127	88	Pass
0.0053	492235	433953	88	Pass
0.0054	474119	418053	88	Pass
0.0056	456889	402818	88	Pass
0.0057	440601	388303	88	Pass
0.0059	425255	374453	88	Pass
0.0060	410796	361434	87	Pass
0.0062	397001	348969	87	Pass
0.0063	383816	336836	87	Pass
0.0064	371073	325313	87	Pass
0.0066	359107	314454	87	Pass
0.0067	347639	303983	87	Pass
0.0069	336614	294067	87	Pass
0.0070	326144	284593	87	Pass
0.0072	316171	275452	87	Pass
0.0073	306532	266643	86	Pass
0.0075	297169	258278	86	Pass
0.0076	288250	250245	86	Pass
0.0077	279718	242544	86	Pass
0.0079	271629	235231	86	Pass
0.0080	263652	228084	86	Pass
0.0082	256006	220993	86	Pass
0.0083	248693	214123	86	Pass
0.0085	241658	207697	85	Pass
0.0086	234899	201381	85	Pass
0.0087	228306	195343	85	Pass
0.0089	221824	189636	85	Pass
0.0090	215675	183986	85	Pass
0.0092	209747	178667	85	Pass
0.0093	203930	173515	85	Pass
0.0095	198223	168584	85	Pass
0.0096	192850	163709	84	Pass
0.0098	187587	159111	84	Pass
0.0099	182601	154623	84	Pass
0.0100	177836	150357	84	Pass
0.0102	173349	146368	84	Pass

0.0103	168640	142158	84	Pass
0.0105	164374	138391	84	Pass
0.0106	160219	134679	84	Pass
0.0108	155953	130912	83	Pass
0.0109	152130	127366	83	Pass
0.0110	148474	124097	83	Pass
0.0112	144651	120663	83	Pass
0.0113	141050	117505	83	Pass
0.0115	137394	114402	83	Pass
0.0116	134125	111466	83	Pass
0.0118	130856	108585	82	Pass
0.0119	127532	105704	82	Pass
0.0121	124541	103045	82	Pass
0.0122	121383	100275	82	Pass
0.0123	118613	97782	82	Pass
0.0125	115843	95345	82	Pass
0.0126	112962	92796	82	Pass
0.0128	110413	90469	81	Pass
0.0129	107865	88253	81	Pass
0.0131	105150	85926	81	Pass
0.0132	102824	83877	81	Pass
0.0134	100275	81661	81	Pass
0.0135	98004	79722	81	Pass
0.0136	95843	77838	81	Pass
0.0138	93572	75954	81	Pass
0.0139	91466	74126	81	Pass
0.0141	89472	72409	80	Pass
0.0142	87367	70580	80	Pass
0.0144	85428	68863	80	Pass
0.0145	83378	67146	80	Pass
0.0146	81605	65594	80	Pass
0.0148	79888	64099	80	Pass
0.0149	78060	62547	80	Pass
0.0151	76397	61052	79	Pass
0.0152	74735	59666	79	Pass
0.0154	73018	58171	79	Pass
0.0155	71467	56786	79	Pass
0.0157	69860	55378	79	Pass
0.0158	68309	54126	79	Pass
0.0159	66869	52908	79	Pass
0.0161	65373	51644	78	Pass
0.0162	64043	50487	78	Pass
0.0164	62769	49373	78	Pass
0.0165	61384	48193	78	Pass
0.0167	60165	47135	78	Pass
0.0168	58835	45994	78	Pass
0.0169	57672	45013	78	Pass

Duration Flows

The Facility PASSED

Flow(cfs)	Predev	Mit	Percentage	Pass/Fail
0.0169	57672	45013	78	Pass
0.0176	52221	40598	77	Pass
0.0183	47301	36825	77	Pass
0.0190	43074	33479	77	Pass
0.0197	39384	30548	77	Pass
0.0204	36105	27927	77	Pass
0.0210	33107	25506	77	Pass
0.0217	30481	23324	76	Pass
0.0224	28072	21473	76	Pass
0.0231	25855	19684	76	Pass
0.0238	23883	18133	75	Pass
0.0245	22121	16759	75	Pass
0.0251	20476	15529	75	Pass
0.0258	18997	14332	75	Pass
0.0265	17734	13268	74	Pass
0.0272	16559	12194	73	Pass
0.0279	15357	11263	73	Pass
0.0286	14299	10393	72	Pass
0.0292	13335	9595	71	Pass
0.0299	12432	8809	70	Pass
0.0306	11590	8088	69	Pass
0.0313	10775	7457	69	Pass
0.0320	10039	6875	68	Pass
0.0327	9318	6366	68	Pass
0.0333	8637	5933	68	Pass
0.0340	8016	5539	69	Pass
0.0347	7451	5158	69	Pass
0.0354	6958	4833	69	Pass
0.0361	6471	4508	69	Pass
0.0367	6044	4212	69	Pass
0.0374	5690	3982	69	Pass
0.0381	5350	3764	70	Pass
0.0388	5049	3544	70	Pass
0.0395	4769	3353	70	Pass
0.0402	4452	3164	71	Pass
0.0408	4191	2964	70	Pass
0.0415	3978	2790	70	Pass
0.0422	3794	2627	69	Pass
0.0429	3606	2498	69	Pass
0.0436	3417	2357	68	Pass
0.0443	3257	2244	68	Pass
0.0449	3078	2130	69	Pass
0.0456	2930	1988	67	Pass
0.0463	2780	1866	67	Pass
0.0470	2637	1748	66	Pass
0.0477	2511	1646	65	Pass
0.0484	2400	1557	64	Pass
0.0490	2281	1478	64	Pass
0.0497	2172	1393	64	Pass
0.0504	2080	1305	62	Pass
0.0511	1979	1230	62	Pass
0.0518	1875	1161	61	Pass
0.0525	1784	1094	61	Pass

0.0531	1681	1037	61	Pass
0.0538	1591	987	62	Pass
0.0545	1504	922	61	Pass
0.0552	1436	863	60	Pass
0.0559	1376	814	59	Pass
0.0566	1297	762	58	Pass
0.0572	1228	700	57	Pass
0.0579	1156	641	55	Pass
0.0586	1098	581	52	Pass
0.0593	1039	530	51	Pass
0.0600	984	483	49	Pass
0.0607	929	432	46	Pass
0.0613	879	388	44	Pass
0.0620	835	349	41	Pass
0.0627	787	325	41	Pass
0.0634	737	307	41	Pass
0.0641	692	290	41	Pass
0.0648	649	269	41	Pass
0.0654	593	251	42	Pass
0.0661	542	233	42	Pass
0.0668	489	213	43	Pass
0.0675	444	193	43	Pass
0.0682	402	172	42	Pass
0.0688	367	156	42	Pass
0.0695	325	136	41	Pass
0.0702	302	124	41	Pass
0.0709	280	111	39	Pass
0.0716	264	99	37	Pass
0.0723	249	88	35	Pass
0.0729	233	80	34	Pass
0.0736	219	69	31	Pass
0.0743	210	62	29	Pass
0.0750	194	56	28	Pass
0.0757	176	52	29	Pass
0.0764	158	45	28	Pass
0.0770	139	44	31	Pass
0.0777	120	42	35	Pass
0.0784	108	41	37	Pass
0.0791	95	39	41	Pass
0.0798	82	39	47	Pass
0.0805	74	38	51	Pass
0.0811	62	36	58	Pass
0.0818	55	34	61	Pass
0.0825	50	31	62	Pass
0.0832	45	28	62	Pass
0.0839	37	27	72	Pass
0.0846	34	26	76	Pass

Water Quality

Water Quality BMP Flow and Volume for POC #1

On-line facility volume: 0.4396 acre-feet

On-line facility target flow: 0.3093 cfs.

Adjusted for 15 min: 0.3093 cfs.

Off-line facility target flow: 0.1697 cfs.

Adjusted for 15 min: 0.1697 cfs.

Wetland Input Volumes

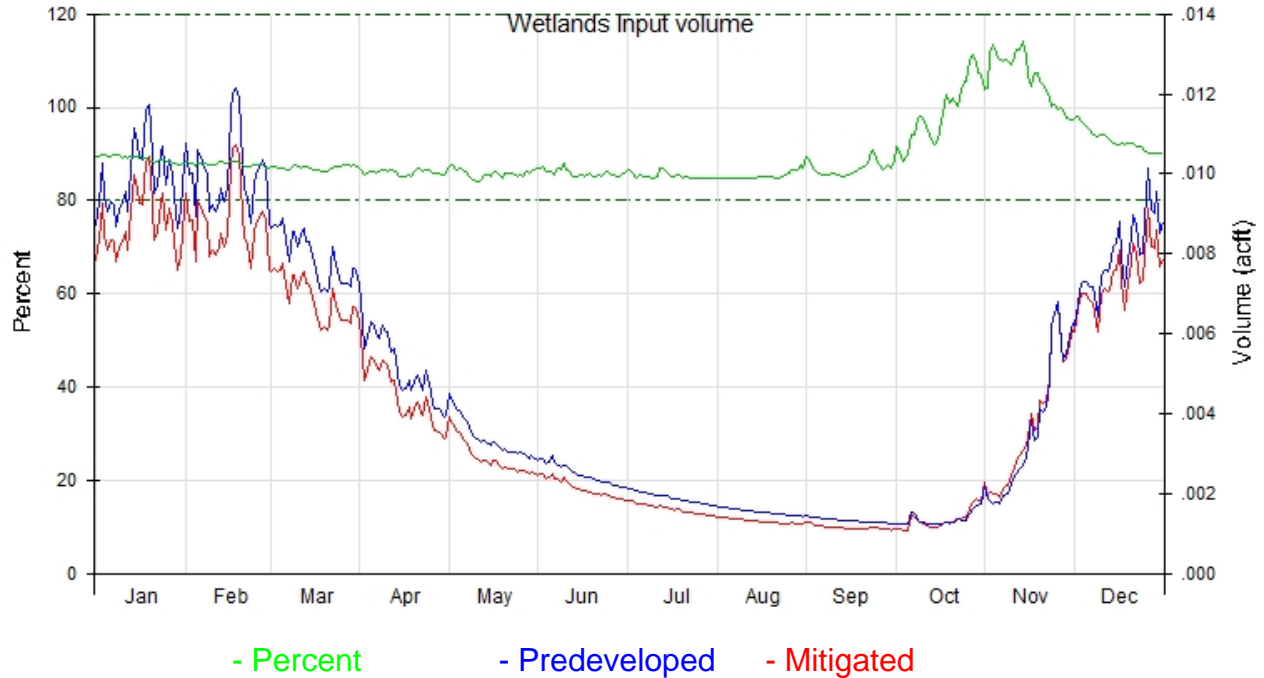

Wetlands Input Volume for POC 1
 Average Annual Volume (acft)
 Series 1: 501 POC 1 Predeveloped flow
 Series 2: 801 POC 1 Mitigated flow

Month	Series 1	Series 2	Percent	Pass/Fail
Jan	0.3050	0.2716	89.0	Pass
Feb	0.2850	0.2505	87.9	Pass
Mar	0.2466	0.2146	87.1	Pass
Apr	0.1570	0.1352	86.1	Pass
May	0.1055	0.0905	85.8	Pass
Jun	0.0754	0.0649	86.0	Pass
Jul	0.0593	0.0506	85.3	Pass
Aug	0.0481	0.0410	85.3	Pass
Sep	0.0402	0.0349	86.9	Pass
Oct	0.0420	0.0415	98.9	Pass
Nov	0.1054	0.1101	104.4	Pass
Dec	0.2443	0.2269	92.9	Pass

Day	Predevel	Mitigated	Percent	Pass/Fail
Jan1	0.0087	0.0078	89.6	Pass
2	0.0093	0.0084	89.5	Pass
3	0.0103	0.0092	89.9	Pass
4	0.0095	0.0085	89.7	Pass
5	0.0091	0.0081	89.4	Pass
6	0.0093	0.0083	89.4	Pass
7	0.0092	0.0083	89.8	Pass
8	0.0087	0.0078	89.7	Pass
9	0.0091	0.0082	89.8	Pass
10	0.0093	0.0083	89.2	Pass
11	0.0096	0.0085	89.3	Pass
12	0.0091	0.0081	89.3	Pass
13	0.0101	0.0091	89.6	Pass
14	0.0111	0.0100	89.6	Pass

15	0.0108	0.0096	89.3	Pass
16	0.0104	0.0093	89.3	Pass
17	0.0103	0.0092	89.2	Pass
18	0.0116	0.0103	89.0	Pass
19	0.0117	0.0104	88.8	Pass
20	0.0112	0.0100	88.6	Pass
21	0.0095	0.0084	88.0	Pass
22	0.0097	0.0086	88.4	Pass
23	0.0105	0.0093	88.8	Pass
24	0.0107	0.0095	88.8	Pass
25	0.0097	0.0086	88.5	Pass
26	0.0104	0.0091	88.3	Pass
27	0.0100	0.0088	88.2	Pass
28	0.0094	0.0083	88.0	Pass
29	0.0086	0.0076	87.7	Pass
30	0.0091	0.0080	87.7	Pass
31	0.0103	0.0091	88.1	Pass
Feb1	0.0108	0.0095	88.2	Pass
2	0.0100	0.0088	88.1	Pass
3	0.0100	0.0088	87.9	Pass
4	0.0089	0.0078	87.3	Pass
5	0.0106	0.0093	87.9	Pass
6	0.0104	0.0092	87.9	Pass
7	0.0102	0.0089	87.9	Pass
8	0.0100	0.0088	87.8	Pass
9	0.0091	0.0079	87.6	Pass
10	0.0092	0.0081	87.6	Pass
11	0.0091	0.0080	87.8	Pass
12	0.0093	0.0082	88.3	Pass
13	0.0096	0.0085	88.2	Pass
14	0.0093	0.0082	88.0	Pass
15	0.0097	0.0085	87.9	Pass
16	0.0115	0.0102	88.2	Pass
17	0.0120	0.0106	88.5	Pass
18	0.0122	0.0107	88.4	Pass
19	0.0119	0.0105	88.1	Pass
20	0.0103	0.0090	87.7	Pass
21	0.0096	0.0084	87.4	Pass
22	0.0094	0.0082	87.4	Pass
23	0.0088	0.0077	87.3	Pass
24	0.0097	0.0085	87.5	Pass
25	0.0100	0.0088	87.7	Pass
26	0.0102	0.0089	87.7	Pass
27	0.0103	0.0091	87.5	Pass
28	0.0102	0.0088	86.9	Pass
29	0.0088	0.0076	87.1	Pass
Mar1	0.0086	0.0075	87.3	Pass
2	0.0087	0.0076	87.5	Pass
3	0.0087	0.0076	87.1	Pass
4	0.0087	0.0076	87.1	Pass
5	0.0089	0.0077	87.0	Pass
6	0.0083	0.0072	86.7	Pass
7	0.0078	0.0068	86.7	Pass
8	0.0086	0.0075	87.4	Pass
9	0.0085	0.0075	87.7	Pass
10	0.0082	0.0071	87.2	Pass
11	0.0085	0.0074	87.0	Pass
12	0.0087	0.0076	87.3	Pass

13	0.0083	0.0073	87.2	Pass
14	0.0083	0.0072	87.0	Pass
15	0.0080	0.0069	86.7	Pass
16	0.0076	0.0066	86.5	Pass
17	0.0074	0.0064	86.5	Pass
18	0.0071	0.0061	86.2	Pass
19	0.0072	0.0062	86.3	Pass
20	0.0071	0.0061	86.3	Pass
21	0.0072	0.0062	86.4	Pass
22	0.0082	0.0071	86.9	Pass
23	0.0077	0.0067	87.4	Pass
24	0.0074	0.0065	87.4	Pass
25	0.0073	0.0063	87.3	Pass
26	0.0073	0.0064	87.5	Pass
27	0.0072	0.0063	87.5	Pass
28	0.0072	0.0063	87.4	Pass
29	0.0076	0.0067	87.5	Pass
30	0.0076	0.0066	87.3	Pass
31	0.0073	0.0063	87.0	Pass
Apr1	0.0063	0.0054	86.3	Pass
2	0.0056	0.0048	85.7	Pass
3	0.0059	0.0051	85.8	Pass
4	0.0063	0.0054	86.1	Pass
5	0.0062	0.0054	86.2	Pass
6	0.0060	0.0052	86.0	Pass
7	0.0059	0.0051	86.3	Pass
8	0.0062	0.0054	86.6	Pass
9	0.0061	0.0052	86.5	Pass
10	0.0060	0.0052	86.4	Pass
11	0.0055	0.0048	86.4	Pass
12	0.0056	0.0049	86.4	Pass
13	0.0051	0.0043	85.7	Pass
14	0.0047	0.0040	85.2	Pass
15	0.0046	0.0039	85.3	Pass
16	0.0046	0.0040	85.3	Pass
17	0.0049	0.0042	85.7	Pass
18	0.0046	0.0039	85.3	Pass
19	0.0048	0.0041	86.3	Pass
20	0.0050	0.0043	87.0	Pass
21	0.0047	0.0041	86.4	Pass
22	0.0046	0.0040	86.2	Pass
23	0.0051	0.0044	86.7	Pass
24	0.0048	0.0041	86.8	Pass
25	0.0043	0.0037	85.9	Pass
26	0.0042	0.0036	85.9	Pass
27	0.0041	0.0036	86.0	Pass
28	0.0041	0.0035	85.7	Pass
29	0.0039	0.0034	85.4	Pass
30	0.0040	0.0034	85.7	Pass
May1	0.0045	0.0039	87.2	Pass
2	0.0043	0.0038	87.7	Pass
3	0.0042	0.0036	86.6	Pass
4	0.0041	0.0035	86.5	Pass
5	0.0040	0.0035	87.1	Pass
6	0.0039	0.0034	86.4	Pass
7	0.0038	0.0032	85.8	Pass
8	0.0037	0.0031	85.2	Pass
9	0.0035	0.0029	84.5	Pass

10	0.0034	0.0029	84.3	Pass
11	0.0033	0.0028	84.2	Pass
12	0.0033	0.0028	84.5	Pass
13	0.0033	0.0028	85.6	Pass
14	0.0033	0.0028	85.4	Pass
15	0.0032	0.0027	85.1	Pass
16	0.0033	0.0028	86.0	Pass
17	0.0033	0.0028	86.4	Pass
18	0.0032	0.0027	85.5	Pass
19	0.0031	0.0026	84.9	Pass
20	0.0031	0.0027	85.8	Pass
21	0.0031	0.0026	85.8	Pass
22	0.0030	0.0026	85.8	Pass
23	0.0031	0.0026	85.4	Pass
24	0.0030	0.0026	85.3	Pass
25	0.0030	0.0026	85.5	Pass
26	0.0030	0.0026	85.2	Pass
27	0.0030	0.0025	86.2	Pass
28	0.0029	0.0025	86.0	Pass
29	0.0030	0.0026	86.4	Pass
30	0.0029	0.0025	86.6	Pass
31	0.0028	0.0025	86.8	Pass
Jun1	0.0029	0.0025	86.9	Pass
2	0.0029	0.0025	87.2	Pass
3	0.0028	0.0024	86.2	Pass
4	0.0028	0.0024	86.3	Pass
5	0.0029	0.0025	85.9	Pass
6	0.0028	0.0024	85.6	Pass
7	0.0027	0.0024	87.0	Pass
8	0.0027	0.0023	86.8	Pass
9	0.0027	0.0024	88.1	Pass
10	0.0027	0.0023	86.7	Pass
11	0.0026	0.0023	86.2	Pass
12	0.0025	0.0022	85.2	Pass
13	0.0025	0.0021	85.1	Pass
14	0.0025	0.0021	85.2	Pass
15	0.0025	0.0021	85.5	Pass
16	0.0024	0.0021	85.3	Pass
17	0.0024	0.0021	85.4	Pass
18	0.0024	0.0021	85.8	Pass
19	0.0024	0.0020	85.1	Pass
20	0.0023	0.0020	85.1	Pass
21	0.0023	0.0020	85.7	Pass
22	0.0023	0.0020	85.1	Pass
23	0.0023	0.0020	85.9	Pass
24	0.0023	0.0020	86.2	Pass
25	0.0023	0.0019	85.6	Pass
26	0.0022	0.0019	85.4	Pass
27	0.0022	0.0019	85.3	Pass
28	0.0022	0.0019	85.2	Pass
29	0.0022	0.0019	86.1	Pass
30	0.0022	0.0018	86.0	Pass
Jul1	0.0021	0.0018	86.8	Pass
2	0.0021	0.0018	86.1	Pass
3	0.0021	0.0018	85.4	Pass
4	0.0021	0.0018	85.0	Pass
5	0.0021	0.0018	85.5	Pass
6	0.0020	0.0017	85.3	Pass

7	0.0020	0.0017	85.3	Pass
8	0.0020	0.0017	85.2	Pass
9	0.0020	0.0017	84.9	Pass
10	0.0020	0.0017	84.7	Pass
11	0.0020	0.0017	85.1	Pass
12	0.0020	0.0017	87.1	Pass
13	0.0019	0.0017	86.8	Pass
14	0.0019	0.0017	86.3	Pass
15	0.0019	0.0016	85.6	Pass
16	0.0019	0.0016	85.2	Pass
17	0.0019	0.0016	85.3	Pass
18	0.0019	0.0016	85.6	Pass
19	0.0019	0.0016	85.1	Pass
20	0.0018	0.0016	84.9	Pass
21	0.0018	0.0015	85.1	Pass
22	0.0018	0.0015	84.9	Pass
23	0.0018	0.0015	84.7	Pass
24	0.0018	0.0015	84.7	Pass
25	0.0018	0.0015	84.7	Pass
26	0.0018	0.0015	84.7	Pass
27	0.0017	0.0015	84.7	Pass
28	0.0017	0.0015	84.7	Pass
29	0.0017	0.0015	84.7	Pass
30	0.0017	0.0014	84.6	Pass
31	0.0017	0.0014	84.7	Pass
Aug1	0.0017	0.0014	84.7	Pass
2	0.0017	0.0014	84.7	Pass
3	0.0017	0.0014	84.9	Pass
4	0.0017	0.0014	84.8	Pass
5	0.0016	0.0014	84.9	Pass
6	0.0016	0.0014	84.9	Pass
7	0.0016	0.0014	84.8	Pass
8	0.0016	0.0014	84.8	Pass
9	0.0016	0.0014	84.7	Pass
10	0.0016	0.0014	84.9	Pass
11	0.0016	0.0013	84.9	Pass
12	0.0016	0.0013	84.8	Pass
13	0.0016	0.0013	84.8	Pass
14	0.0016	0.0013	84.9	Pass
15	0.0015	0.0013	85.0	Pass
16	0.0015	0.0013	85.0	Pass
17	0.0015	0.0013	85.2	Pass
18	0.0015	0.0013	85.2	Pass
19	0.0015	0.0013	85.0	Pass
20	0.0015	0.0013	85.0	Pass
21	0.0015	0.0013	84.9	Pass
22	0.0015	0.0013	85.0	Pass
23	0.0015	0.0013	85.3	Pass
24	0.0015	0.0013	85.7	Pass
25	0.0015	0.0013	86.0	Pass
26	0.0015	0.0013	86.7	Pass
27	0.0015	0.0013	86.4	Pass
28	0.0014	0.0013	86.8	Pass
29	0.0014	0.0013	87.5	Pass
30	0.0014	0.0012	87.1	Pass
31	0.0014	0.0013	89.5	Pass
Sep1	0.0014	0.0013	88.7	Pass
2	0.0014	0.0012	87.4	Pass

3	0.0014	0.0012	86.7	Pass
4	0.0014	0.0012	86.0	Pass
5	0.0014	0.0012	85.7	Pass
6	0.0014	0.0012	85.4	Pass
7	0.0014	0.0012	85.5	Pass
8	0.0014	0.0012	85.7	Pass
9	0.0014	0.0012	85.7	Pass
10	0.0014	0.0012	85.6	Pass
11	0.0014	0.0012	85.4	Pass
12	0.0013	0.0012	85.3	Pass
13	0.0013	0.0011	85.3	Pass
14	0.0013	0.0011	85.4	Pass
15	0.0013	0.0011	85.4	Pass
16	0.0013	0.0011	85.7	Pass
17	0.0013	0.0011	86.4	Pass
18	0.0013	0.0011	87.0	Pass
19	0.0013	0.0011	86.8	Pass
20	0.0013	0.0011	87.3	Pass
21	0.0013	0.0011	88.0	Pass
22	0.0013	0.0012	90.5	Pass
23	0.0013	0.0012	91.0	Pass
24	0.0013	0.0011	89.3	Pass
25	0.0013	0.0011	87.6	Pass
26	0.0013	0.0011	86.8	Pass
27	0.0013	0.0011	87.1	Pass
28	0.0013	0.0011	87.7	Pass
29	0.0013	0.0011	87.1	Pass
30	0.0013	0.0011	88.5	Pass
Oct1	0.0013	0.0011	91.5	Pass
2	0.0012	0.0011	90.6	Pass
3	0.0012	0.0011	88.6	Pass
4	0.0012	0.0011	89.4	Pass
5	0.0012	0.0011	89.7	Pass
6	0.0016	0.0015	94.1	Pass
7	0.0015	0.0014	94.1	Pass
8	0.0014	0.0013	97.7	Pass
9	0.0013	0.0013	98.1	Pass
10	0.0013	0.0012	97.6	Pass
11	0.0013	0.0012	96.0	Pass
12	0.0012	0.0012	94.3	Pass
13	0.0012	0.0011	92.9	Pass
14	0.0012	0.0011	91.9	Pass
15	0.0012	0.0012	93.2	Pass
16	0.0013	0.0012	96.9	Pass
17	0.0013	0.0012	98.4	Pass
18	0.0013	0.0013	102.7	Pass
19	0.0013	0.0013	100.8	Pass
20	0.0013	0.0013	102.0	Pass
21	0.0013	0.0013	101.4	Pass
22	0.0014	0.0014	100.2	Pass
23	0.0013	0.0014	103.8	Pass
24	0.0013	0.0014	105.6	Pass
25	0.0013	0.0014	105.5	Pass
26	0.0015	0.0016	109.9	Pass
27	0.0016	0.0018	111.4	Pass
28	0.0017	0.0019	109.9	Pass
29	0.0017	0.0018	107.2	Pass
30	0.0017	0.0019	107.1	Pass

31	0.0022	0.0023	103.7	Pass
Nov1	0.0019	0.0020	104.2	Pass
2	0.0018	0.0020	111.8	Pass
3	0.0017	0.0020	113.3	Pass
4	0.0018	0.0020	111.6	Pass
5	0.0017	0.0019	110.1	Pass
6	0.0019	0.0021	109.9	Pass
7	0.0020	0.0022	110.2	Pass
8	0.0020	0.0022	110.0	Pass
9	0.0023	0.0025	109.2	Pass
10	0.0024	0.0027	111.0	Pass
11	0.0025	0.0028	112.6	Pass
12	0.0026	0.0030	112.2	Pass
13	0.0027	0.0031	114.3	Pass
14	0.0029	0.0032	111.3	Pass
15	0.0032	0.0034	106.8	Pass
16	0.0038	0.0040	104.6	Pass
17	0.0033	0.0036	107.3	Pass
18	0.0034	0.0037	107.4	Pass
19	0.0041	0.0044	105.6	Pass
20	0.0041	0.0043	105.0	Pass
21	0.0042	0.0043	103.8	Pass
22	0.0048	0.0049	101.9	Pass
23	0.0062	0.0062	100.1	Pass
24	0.0065	0.0065	100.4	Pass
25	0.0068	0.0068	99.6	Pass
26	0.0058	0.0057	99.8	Pass
27	0.0053	0.0053	99.5	Pass
28	0.0055	0.0054	97.7	Pass
29	0.0059	0.0058	97.4	Pass
30	0.0063	0.0061	97.4	Pass
Dec1	0.0062	0.0061	97.5	Pass
2	0.0068	0.0066	97.9	Pass
3	0.0073	0.0070	96.9	Pass
4	0.0073	0.0070	96.2	Pass
5	0.0073	0.0070	95.8	Pass
6	0.0072	0.0068	95.2	Pass
7	0.0072	0.0068	94.1	Pass
8	0.0067	0.0063	93.7	Pass
9	0.0064	0.0060	93.9	Pass
10	0.0074	0.0070	94.2	Pass
11	0.0076	0.0071	94.0	Pass
12	0.0076	0.0071	93.4	Pass
13	0.0076	0.0071	92.9	Pass
14	0.0082	0.0076	92.3	Pass
15	0.0082	0.0076	91.9	Pass
16	0.0088	0.0081	92.0	Pass
17	0.0079	0.0073	92.5	Pass
18	0.0072	0.0066	92.1	Pass
19	0.0079	0.0072	92.3	Pass
20	0.0084	0.0078	92.5	Pass
21	0.0090	0.0083	92.3	Pass
22	0.0087	0.0080	91.8	Pass
23	0.0080	0.0073	91.5	Pass
24	0.0080	0.0073	91.2	Pass
25	0.0088	0.0080	90.5	Pass
26	0.0102	0.0092	90.2	Pass
27	0.0091	0.0082	90.1	Pass

28	0.0090	0.0081	90.2	Pass
29	0.0095	0.0086	90.3	Pass
30	0.0085	0.0077	90.0	Pass
31	0.0088	0.0079	89.7	Pass

LID Report

LID Technique	Used for Treatment ?	Total Volume Needs Treatment (ac-ft)	Volume Through Facility (ac-ft)	Infiltration Volume (ac-ft)	Cumulative Volume Infiltration Credit	Percent Volume Infiltrated	Water Quality	Percent Water Quality Treated	Comment
Total Volume Infiltrated		0.00	0.00	0.00		0.00	0.00	0%	No Treat. Credit
Compliance with LID Standard 8% of 2-yr to 50% of 2-yr									Duration Analysis Result = Passed

Model Default Modifications

Total of 0 changes have been made.

PERLND Changes

No PERLND changes have been made.

IMPLND Changes

No IMPLND changes have been made.

Appendix
Predeveloped Schematic



DB - A EG -
Wetland
1.21ac

Mitigated Schematic



DB - A -FG
Wetland
1.05ac

Predeveloped UCI File

RUN

GLOBAL

WVHM4 model simulation
START 1901 10 01 END 2059 09 30
RUN INTERP OUTPUT LEVEL 3 0
RESUME 0 RUN 1 UNIT SYSTEM 1
END GLOBAL

FILES

<File> <Un#> <-----File Name----->***
<-ID-> ***
WDM 26 SHBTC-Wetland Analysis.wdm
MESSU 25 PreSHBTC-Wetland Analysis.MES
27 PreSHBTC-Wetland Analysis.L61
28 PreSHBTC-Wetland Analysis.L62
30 POCSHBTC-Wetland Analysis1.dat

END FILES

OPN SEQUENCE

INGRP INDELT 00:15
PERLND 11
PERLND 12
COPY 501
DISPLY 1

END INGRP

END OPN SEQUENCE

DISPLY

DISPLY-INFO1

- #<-----Title----->***TRAN PIVL DIG1 FIL1 PYR DIG2 FIL2 YRND
1 DB - A EG - Wetland MAX 1 2 30 9

END DISPLY-INFO1

END DISPLY

COPY

TIMESERIES

- # NPT NMN ***
1 1 1
501 1 1

END TIMESERIES

END COPY

GENER

OPCODE

OPCD ***

END OPCODE

PARM

K ***

END PARM

END GENER

PERLND

GEN-INFO

<PLS ><-----Name----->NBLKS Unit-systems Printer ***
- # User t-series Engl Metr ***
in out ***

11 C, Forest, Mod 1 1 1 1 27 0
12 C, Forest, Steep 1 1 1 1 27 0

END GEN-INFO

*** Section PWATER***

ACTIVITY

<PLS > ***** Active Sections *****
- # ATMP SNOW PWAT SED PST PWG PQAL MSTL PEST NITR PHOS TRAC ***
11 0 0 1 0 0 0 0 0 0 0 0 0
12 0 0 1 0 0 0 0 0 0 0 0 0

END ACTIVITY

PRINT-INFO

<PLS > ***** Print-flags ***** PIVL PYR
- # ATMP SNOW PWAT SED PST PWG PQAL MSTL PEST NITR PHOS TRAC *****

```

11      0  0  4  0  0  0  0  0  0  0  0  0  1  9
12      0  0  4  0  0  0  0  0  0  0  0  0  1  9
END PRINT-INFO

```

```

PWAT-PARM1
<PLS > PWATER variable monthly parameter value flags ***
# - # CSNO RTOP UZFG VCS VUZ VNN VIFW VIRC VLE INFC HWT ***
11      0  0  0  0  0  0  0  0  0  0  0  0
12      0  0  0  0  0  0  0  0  0  0  0  0
END PWAT-PARM1

```

```

PWAT-PARM2
<PLS > PWATER input info: Part 2 ***
# - # ***FOREST LZSN INFILT LRSUR SLSUR KVARY AGWRC
11      0  4.5 0.08 400 0.1 0.5 0.996
12      0  4.5 0.08 400 0.15 0.5 0.996
END PWAT-PARM2

```

```

PWAT-PARM3
<PLS > PWATER input info: Part 3 ***
# - # ***PETMAX PETMIN INFEXP INFILD DEEPFR BASETP AGWETP
11      0  0  2  2  0  0  0
12      0  0  2  2  0  0  0
END PWAT-PARM3

```

```

PWAT-PARM4
<PLS > PWATER input info: Part 4 ***
# - # CEPSC UZSN NSUR INTFW IRC LZETP ***
11      0.2 0.5 0.35 6 0.5 0.7
12      0.2 0.3 0.35 6 0.3 0.7
END PWAT-PARM4

```

```

PWAT-STATE1
<PLS > *** Initial conditions at start of simulation
ran from 1990 to end of 1992 (pat 1-11-95) RUN 21 ***
# - # *** CEPS SURS UZS IFWS LZS AGWS GWVS
11      0  0  0  0  2.5 1 0
12      0  0  0  0  2.5 1 0
END PWAT-STATE1

```

END PERLND

IMPLND

```

GEN-INFO
<PLS ><-----Name-----> Unit-systems Printer ***
# - # User t-series Engl Metr ***
in out ***
END GEN-INFO
*** Section IWATER***

```

```

ACTIVITY
<PLS > ***** Active Sections *****
# - # ATMP SNOW IWAT SLD IWG IQAL ***
END ACTIVITY

```

```

PRINT-INFO
<ILS > ***** Print-flags ***** PIVL PYR
# - # ATMP SNOW IWAT SLD IWG IQAL *****
END PRINT-INFO

```

```

IWAT-PARM1
<PLS > IWATER variable monthly parameter value flags ***
# - # CSNO RTOP VRS VNN RTLI ***
END IWAT-PARM1

```

```

IWAT-PARM2
<PLS > IWATER input info: Part 2 ***
# - # *** LRSUR SLSUR NSUR RETSC
END IWAT-PARM2

```

IWAT-PARM3

<PLS > IWATER input info: Part 3 ***
- # ***PETMAX PETMIN
END IWAT-PARM3

IWAT-STATE1
<PLS > *** Initial conditions at start of simulation
- # *** RETS SURS
END IWAT-STATE1

END IMPLND

SCHEMATIC
<-Source-> <--Area--> <-Target-> MBLK ***
<Name> # <-factor-> <Name> # Tbl# ***
DB - A EG - Wetland***
PERLND 11 0.66 COPY 501 12
PERLND 11 0.66 COPY 501 13
PERLND 11 0.66 COPY 501 14
PERLND 12 0.55 COPY 501 12
PERLND 12 0.55 COPY 501 13
PERLND 12 0.55 COPY 501 14

*****Routing*****
END SCHEMATIC

NETWORK
<-Volume-> <-Grp> <-Member-><--Mult-->Tran <-Target vols> <-Grp> <-Member-> ***
<Name> # <Name> # #<-factor->strg <Name> # # <Name> # # ***
COPY 501 OUTPUT MEAN 1 1 48.4 DISPLY 1 INPUT TIMSER 1

<-Volume-> <-Grp> <-Member-><--Mult-->Tran <-Target vols> <-Grp> <-Member-> ***
<Name> # <Name> # #<-factor->strg <Name> # # <Name> # # ***
END NETWORK

RCHRES
GEN-INFO
RCHRES Name Nexits Unit Systems Printer ***
- #<-----><----> User T-series Engl Metr LKFG ***
in out ***
END GEN-INFO
*** Section RCHRES***

ACTIVITY
<PLS > ***** Active Sections *****
- # HYFG ADFG CNFG HTFG SDFG GQFG OXFG NUGF PKFG PHFG ***
END ACTIVITY

PRINT-INFO
<PLS > ***** Print-flags ***** PIVL PYR
- # HYDR ADCA CONS HEAT SED GQL OXRX NUTR PLNK PHCB PIVL PYR *****
END PRINT-INFO

HYDR-PARM1
RCHRES Flags for each HYDR Section ***
- # VC A1 A2 A3 ODFVFG for each *** ODGTFG for each FUNCT for each
FG FG FG FG possible exit *** possible exit possible exit
* *
END HYDR-PARM1

HYDR-PARM2
- # FTABNO LEN DELTH STCOR KS DB50 ***
<-----><-----><-----><-----><-----><-----><-----> ***
END HYDR-PARM2

HYDR-INIT
RCHRES Initial conditions for each HYDR section ***
- # *** VOL Initial value of COLIND Initial value of OUTDGT
*** ac-ft for each possible exit for each possible exit
<-----><-----> <---><---><---><---><---> *** <---><---><---><---><--->

END HYDR-INIT
END RCHRES

SPEC-ACTIONS
END SPEC-ACTIONS
FTABLES
END FTABLES

EXT SOURCES
<-Volume-> <Member> SsysSgap<--Mult-->Tran <-Target vols> <-Grp> <-Member-> ***
<Name> # <Name> # tem strg<-factor->strg <Name> # # <Name> # # ***
WDM 2 PREC ENGL 1 PERLND 1 999 EXTNL PREC
WDM 2 PREC ENGL 1 IMPLND 1 999 EXTNL PREC
WDM 1 EVAP ENGL 1 PERLND 1 999 EXTNL PETINP
WDM 1 EVAP ENGL 1 IMPLND 1 999 EXTNL PETINP

END EXT SOURCES

EXT TARGETS
<-Volume-> <-Grp> <-Member-><--Mult-->Tran <-Volume-> <Member> Tsys Tgap Amd ***
<Name> # <Name> # #<-factor->strg <Name> # <Name> tem strg strg***
COPY 501 OUTPUT MEAN 1 1 48.4 WDM 501 FLOW ENGL REPL
END EXT TARGETS

MASS-LINK
<Volume> <-Grp> <-Member-><--Mult--> <Target> <-Grp> <-Member->***
<Name> <Name> # #<-factor-> <Name> <Name> # #***
MASS-LINK 12
PERLND PWATER SURO 0.083333 COPY INPUT MEAN
END MASS-LINK 12

MASS-LINK 13
PERLND PWATER IFWO 0.083333 COPY INPUT MEAN
END MASS-LINK 13

MASS-LINK 14
PERLND PWATER AGWO 0.083333 COPY INPUT MEAN
END MASS-LINK 14

END MASS-LINK

END RUN

Mitigated UCI File

RUN

GLOBAL

WVHM4 model simulation
START 1901 10 01 END 2059 09 30
RUN INTERP OUTPUT LEVEL 3 0
RESUME 0 RUN 1 UNIT SYSTEM 1
END GLOBAL

FILES

<File>	<Un#>	<-----File Name----->	***
<-ID->			***
WDM	26	SHBTC-Wetland Analysis.wdm	
MESSU	25	MitSHBTC-Wetland Analysis.MES	
	27	MitSHBTC-Wetland Analysis.L61	
	28	MitSHBTC-Wetland Analysis.L62	
	30	POCSHBTC-Wetland Analysis1.dat	

END FILES

OPN SEQUENCE

INGRP INDELT 00:15

PERLND 17
PERLND 12
PERLND 11
COPY 501
DISPLY 1

END INGRP

END OPN SEQUENCE

DISPLY

DISPLY-INF01

#	-	#	<-----Title----->	***	TRAN	PIVL	DIG1	FIL1	PYR	DIG2	FIL2	YRND
1			DB - A -FG Wetland		MAX				1	2	30	9

END DISPLY-INF01

END DISPLY

COPY

TIMESERIES

#	-	#	NPT	NMN	***
1			1	1	
501			1	1	

END TIMESERIES

END COPY

GENER

OPCODE

OPCD ***

END OPCODE

PARM

K ***

END PARM

END GENER

PERLND

GEN-INFO

<PLS >	<-----Name----->	NBLKS	Unit-systems	Printer	***	
#	-	#	User	t-series	Engl Metr	***
			in	out		***

17	C, Lawn, Mod	1	1	1	1	27	0
12	C, Forest, Steep	1	1	1	1	27	0
11	C, Forest, Mod	1	1	1	1	27	0

END GEN-INFO

*** Section PWATER***

ACTIVITY

<PLS > ***** Active Sections *****

#	-	#	ATMP	SNOW	PWAT	SED	PST	PWG	PQAL	MSTL	PEST	NITR	PHOS	TRAC	***
17			0	0	1	0	0	0	0	0	0	0	0	0	
12			0	0	1	0	0	0	0	0	0	0	0	0	
11			0	0	1	0	0	0	0	0	0	0	0	0	

END ACTIVITY

```

PRINT-INFO
<PLS > ***** Print-flags ***** PIVL  PYR
# - # ATMP SNOW PWAT  SED  PST  PWG  PQAL MSTL PEST NITR PHOS TRAC  *****
17      0    0    4    0    0    0    0    0    0    0    0    0    0    1    9
12      0    0    4    0    0    0    0    0    0    0    0    0    0    1    9
11      0    0    4    0    0    0    0    0    0    0    0    0    0    1    9
END PRINT-INFO

```

```

PWAT-PARM1
<PLS > PWATER variable monthly parameter value flags ***
# - # CSNO RTOP UZFG  VCS  VUZ  VNN VIFW VIRC  VLE INFC  HWT ***
17      0    0    0    0    0    0    0    0    0    0    0
12      0    0    0    0    0    0    0    0    0    0    0
11      0    0    0    0    0    0    0    0    0    0    0
END PWAT-PARM1

```

```

PWAT-PARM2
<PLS > PWATER input info: Part 2 *****
# - # ***FOREST  LZSN  INFILT  LRSUR  SLSUR  KVARY  AGWRC
17      0          4.5    0.03    400    0.1    0.5    0.996
12      0          4.5    0.08    400    0.15   0.5    0.996
11      0          4.5    0.08    400    0.1    0.5    0.996
END PWAT-PARM2

```

```

PWAT-PARM3
<PLS > PWATER input info: Part 3 *****
# - # ***PETMAX  PETMIN  INFEXP  INFILD  DEEPFR  BASETP  AGWETP
17      0          0          2          2          0          0          0
12      0          0          2          2          0          0          0
11      0          0          2          2          0          0          0
END PWAT-PARM3

```

```

PWAT-PARM4
<PLS > PWATER input info: Part 4 *****
# - # CEPSC  UZSN  NSUR  INTFW  IRC  LZETP ***
17      0.1    0.25  0.25    6      0.5    0.25
12      0.2    0.3    0.35    6      0.3    0.7
11      0.2    0.5    0.35    6      0.5    0.7
END PWAT-PARM4

```

```

PWAT-STATE1
<PLS > *** Initial conditions at start of simulation
ran from 1990 to end of 1992 (pat 1-11-95) RUN 21 ***
# - # *** CEPS  SURS  UZS  IFWS  LZS  AGWS  GWVS
17      0          0          0          0      2.5    1          0
12      0          0          0          0      2.5    1          0
11      0          0          0          0      2.5    1          0
END PWAT-STATE1

```

END PERLND

IMPLND

```

GEN-INFO
<PLS ><-----Name----->  Unit-systems  Printer ***
# - #                          User t-series Engl Metr ***
                              in out      ***
END GEN-INFO
*** Section IWATER***

```

```

ACTIVITY
<PLS > ***** Active Sections *****
# - # ATMP SNOW IWAT  SLD  IWG IQAL  ***
END ACTIVITY

```

```

PRINT-INFO
<ILS > ***** Print-flags ***** PIVL  PYR
# - # ATMP SNOW IWAT  SLD  IWG IQAL  *****
END PRINT-INFO

```

```

IWAT-PARM1
<PLS > IWATER variable monthly parameter value flags ***

```

```

# - # CSNO RTOP VRS VNN RTLI ***
END IWAT-PARM1

IWAT-PARM2
<PLS > IWATER input info: Part 2 ***
# - # *** LSUR SLSUR NSUR RETSC
END IWAT-PARM2

IWAT-PARM3
<PLS > IWATER input info: Part 3 ***
# - # ***PETMAX PETMIN
END IWAT-PARM3

IWAT-STATE1
<PLS > *** Initial conditions at start of simulation
# - # *** RETS SURS
END IWAT-STATE1

END IMPLND

SCHEMATIC
<-Source-> <--Area--> <-Target-> MBLK ***
<Name> # <-factor-> <Name> # Tbl# ***
DB - A -FG Wetland***
PERLND 17 0.15 COPY 501 12
PERLND 17 0.15 COPY 501 13
PERLND 17 0.15 COPY 501 14
PERLND 12 0.45 COPY 501 12
PERLND 12 0.45 COPY 501 13
PERLND 12 0.45 COPY 501 14
PERLND 11 0.45 COPY 501 12
PERLND 11 0.45 COPY 501 13
PERLND 11 0.45 COPY 501 14

*****Routing*****
END SCHEMATIC

NETWORK
<-Volume-> <-Grp> <-Member-><--Mult-->Tran <-Target vols> <-Grp> <-Member-> ***
<Name> # <Name> # #<-factor->strg <Name> # # <Name> # # ***
COPY 501 OUTPUT MEAN 1 1 48.4 DISPLY 1 INPUT TIMSER 1

<-Volume-> <-Grp> <-Member-><--Mult-->Tran <-Target vols> <-Grp> <-Member-> ***
<Name> # <Name> # #<-factor->strg <Name> # # <Name> # # ***
END NETWORK

RCHRES
GEN-INFO
RCHRES Name Nexits Unit Systems Printer ***
# - #<-----><----> User T-series Engl Metr LKFG ***
in out ***

END GEN-INFO
*** Section RCHRES***

ACTIVITY
<PLS > ***** Active Sections *****
# - # HYFG ADFG CNFG HTFG SDFG GQFG OXFG NUFQ PKFG PHFG ***
END ACTIVITY

PRINT-INFO
<PLS > ***** Print-flags ***** PIVL PYR
# - # HYDR ADCA CONS HEAT SED GQL OXRX NUTR PLNK PHCB PIVL PYR *****
END PRINT-INFO

HYDR-PARM1
RCHRES Flags for each HYDR Section ***
# - # VC A1 A2 A3 ODFVFG for each *** ODGTFG for each FUNCT for each
FG FG FG FG possible exit *** possible exit possible exit

```

Predeveloped HSPF Message File

Mitigated HSPF Message File

Disclaimer

Legal Notice

This program and accompanying documentation are provided 'as-is' without warranty of any kind. The entire risk regarding the performance and results of this program is assumed by End User. Clear Creek Solutions Inc. and the governmental licensee or sublicensees disclaim all warranties, either expressed or implied, including but not limited to implied warranties of program and accompanying documentation. In no event shall Clear Creek Solutions Inc. be liable for any damages whatsoever (including without limitation to damages for loss of business profits, loss of business information, business interruption, and the like) arising out of the use of, or inability to use this program even if Clear Creek Solutions Inc. or their authorized representatives have been advised of the possibility of such damages. Software Copyright © by : Clear Creek Solutions, Inc. 2005-2022; All Rights Reserved.

Clear Creek Solutions, Inc.
6200 Capitol Blvd. Ste F
Olympia, WA. 98501
Toll Free 1(866)943-0304
Local (360)943-0304

www.clearcreeksolutions.com

Appendix E

StormShed Conveyance Calculations

Provide underdrain sizing calcs (length and perforations) for Alignment H considering tributary area to bioswale and Ecology requirement to drain the BSM within 48 hours.
[Storm Report; Pg 337 of 347]

Engr Clarify-CB1 thru CB3 will be under backwater influence during large storm events (top of riser at EL 481.51). Is there a concern for localized flooding due to the backwater condition?
[Storm Report; Pg 337 of 347]

StormShed Conveyance Calculations: SHBTC Parking Expansion

Layout Report: Storm Network

Event	Precip (in)
other	1.20
2 yr 24 hr	2.00
10 year	3.00
25 year	3.50
100 year	4.10

Reach Records

Record Id: Bio-Swale

Section Shape:	Ditch		
Uniform Flow Method:	Manning's	Coefficient:	0.009
Routing Method:	Travel Time Shift	Contributing Hyd	
DnNode	CB #6	UpNode	Top of Align H
Length	185.00 ft	Slope	5.81%
Bottom Width	3.00 ft	Top of Bank	11.00 ft
SS1	3.00v:1h	SS2	3.00v:1h
Up Invert	497.00 ft	Dn Invert	486.25 ft

Record Id: Entry Swale

Section Shape:	Ditch		
Uniform Flow Method:	Manning's	Coefficient:	0.11
Routing Method:	Travel Time Shift	Contributing Hyd	
DnNode	CB #7	UpNode	Entry Swale
Length	300.00 ft	Slope	0.67%
Bottom Width	2.00 ft	Top of Bank	9.50 ft
SS1	3.00v:1h	SS2	3.00v:1h
Up Invert	489.50 ft	Dn Invert	487.50 ft

Record Id: Pipe 001

Section Shape:	Circular		
Uniform Flow Method:	Manning's	Coefficient:	0.012
Routing Method:	Travel Time Shift	Contributing Hyd	
DnNode	MH #1	UpNode	CB #7
Material	unspecified	Size	12 in Diam
Ent Losses	Groove End w/Headwall		
Length	19.00 ft	Slope	0.49%
Up Invert	483.412 ft	Dn Invert	483.318 ft
Conduit Constraints			
Min Vel	Max Vel	Min Slope	Max Slope
2.00 ft/s	15.00 ft/s	0.50%	2.00%
Drop across MH	0.00 ft	Ex/Infil Rate	0.00 in/hr

Record Id: Pipe 002

Section Shape:	Circular		
Uniform Flow Method:	Manning's	Coefficient:	0.012
Routing Method:	Travel Time Shift	Contributing Hyd	
DnNode	MH #2	UpNode	MH #1
Material	unspecified	Size	12 in Diam
Ent Losses	Groove End w/Headwall		
Length	62.00 ft	Slope	2.05%
Up Invert	483.318 ft	Dn Invert	482.049 ft
Conduit Constraints			
Min Vel	Max Vel	Min Slope	Max Slope
2.00 ft/s	15.00 ft/s	0.50%	2.00%
Drop across MH	0.00 ft	Ex/Infil Rate	0.00 in/hr

Record Id: Pipe 003

Section Shape:	Circular		
Uniform Flow Method:	Manning's	Coefficient:	0.009
Routing Method:	Travel Time Shift	Contributing Hyd	
DnNode	MH #2	UpNode	CB #6
Material	Closed Conduits, Concrete Pipe	Size	12 in Diam
Ent Losses	Groove End w/Headwall		
Length	15.50 ft	Slope	0.50%
Up Invert	482.126 ft	Dn Invert	482.049 ft
Conduit Constraints			
Min Vel	Max Vel	Min Slope	Max Slope
2.00 ft/s	15.00 ft/s	0.50%	2.00%
		Min Cover	3.00 ft
Drop across MH	0.00 ft	Ex/Infil Rate	0.00 in/hr

Record Id: Pipe 004

Section Shape:	Circular		
Uniform Flow Method:	Manning's	Coefficient:	0.009
Routing Method:	Travel Time Shift	Contributing Hyd	
DnNode	Stormchamber	UpNode	MH #2
Material	Closed Conduits, Concrete Pipe	Size	12 in Diam
Ent Losses	Groove End w/Headwall		
Length	15.50 ft	Slope	0.50%
Up Invert	482.049 ft	Dn Invert	481.972 ft
Conduit Constraints			
Min Vel	Max Vel	Min Slope	Max Slope
2.00 ft/s	15.00 ft/s	0.50%	2.00%
		Min Cover	3.00 ft
Drop across MH	0.00 ft	Ex/Infil Rate	0.00 in/hr

Record Id: Underdrain

Section Shape:	Circular		
Uniform Flow Method:	Manning's	Coefficient:	0.012
Routing Method:	Travel Time Shift	Contributing Hyd	
DnNode	CB #6	UpNode	Bottom of Swale
Material	Closed Conduits, Thermoplastic Pipe, Solid wall polyvinyl chloride (PVC)	Size	6 in Diam
Ent Losses	Groove End w/Headwall		
Length	27.00 ft	Slope	5.71%
Up Invert	484.00 ft	Dn Invert	482.459 ft
Conduit Constraints			
Min Vel	Max Vel	Min Slope	Max Slope
2.00 ft/s	15.00 ft/s	0.50%	2.00%
			Min Cover
			3.00 ft
Drop across MH	0.00 ft	Ex/Infil Rate	0.00 in/hr

Node Records

Record Id: CB #6

Descrip:	Prototype Record	Increment	0.10 ft
Start El.	482.126 ft	Max El.	487.126 ft
Void Ratio	100.00		
Condition	Existing	Structure Type	CB-TYPE 1-48
		Channelization	No Special Shape
Catch	0.00 ft	Bottom Area	12.5664 sf
MH/CB Type Node			

Record Id: CB #7

Descrip:	Prototype Record	Increment	0.10 ft
Start El.	483.412 ft	Max El.	487.90 ft
Void Ratio	100.00		
Condition	Proposed	Structure Type	CB-TYPE 1
		Channelization	No Special Shape
Catch	0.00 ft	Bottom Area	3.97 sf
MH/CB Type Node			

Record Id: Entry Swale

Descrip:	Prototype Record	Increment	0.10 ft
Start El.	490.00 ft	Max El.	492.00 ft
Void Ratio	100.00		
Dummy Type Node			

Record Id: MH #1

Descrip:	Prototype Record	Increment	0.10 ft
Start El.	483.318 ft	Max El.	488.45 ft
Void Ratio	100.00		
Condition	Proposed	Structure Type	MH-TYPE 1-48
		Channelization	No Special Shape
Catch	0.00 ft	Bottom Area	12.5664 sf
MH/CB Type Node			

Record Id: MH #2

Descrip:	Prototype Record	Increment	0.10 ft
Start El.	482.049 ft	Max El.	488.143 ft
Void Ratio	100.00		
Condition	Existing	Structure Type	CB-TYPE 1-48
		Channelization	No Special Shape
Catch	0.00 ft	Bottom Area	12.5664 sf
MH/CB Type Node			

Record Id: Stormchamber

Descrip:	NDS Stormchamber	Increment	0.10 ft
Start El.	100.00 ft	Max El.	108.00 ft
Void Ratio	100.00		
Dummy Type Node			

Record Id: Top of Align H

Descrip:	Prototype Record	Increment	0.10 ft
Start El.	498.00 ft	Max El.	500.00 ft
Void Ratio	100.00		
Dummy Type Node			

Record Id: Bottom of Swale

Descrip:	Prototype Record	Increment	0.10 ft
Start El.	486.20 ft	Max El.	490.00 ft
Void Ratio	100.00		
Dummy Type Node			

Contributing Drainage Areas

Record Id: Align, H contributing area

Design Method	SCS	Rainfall type	TYPE1a.rac
Hyd Intv	10.00 min	Peaking Factor	484.00
Storm Duration	24.00 hrs	Abstraction Coeff	0.20
Pervious Area	0.05 ac	DCIA	0.85 ac
Pervious CN	86.00	DC CN	98.00
Pervious TC	5.00 min	DC TC	5.00 min

Pervious CN Calc		
Description	SubArea	Sub cn
Golf crse/cemeteries/landscaping (>75% grass)	0.05 ac	86.00
Pervious Compositd CN (AMC 2)		86.00

Pervious TC Calc						
Type	Description	Length	Slope	Coeff	Misc	TT
Shallow	Short grass, pasture and lawns (n=0.030)	195.00 ft	6.0%	0.03		1.24 min
Pervious TC						1.24 min

DCI - CN Calc		
Description	SubArea	Sub cn
Paved curbs and storm sewers	0.85 ac	98.00
DC Compositd CN (AMC 2)		98.00

DCI - TC Calc						
Type	Description	Length	Slope	Coeff	Misc	TT
Sheet	Smooth Surfaces. 0.011	75.00 ft	6.0%	0.011	0.00 in	0.7846 min
Shallow	Short grass, pasture and lawns (n=0.030)	195.00 ft	6.0%	0.03		1.24 min
Pervious TC						2.0245 min

Record Id: Entry Road

Design Method	SCS	Rainfall type	TYPE1a.rac
Hyd Intv	10.00 min	Peaking Factor	484.00
Storm Duration	24.00 hrs	Abstraction Coeff	0.20
Pervious Area	1.10 ac	DCIA	0.20 ac
Pervious CN	81.23	DC CN	98.00
Pervious TC	20.0675 min	DC TC	5.00 min

Pervious CN Calc		
Description	SubArea	Sub cn
Golf crse/cemeteries/landscaping (>75% grass)	0.05 ac	86.00
Wood/forest land (yound 2nd growth/brush)	1.05 ac	81.00
Pervious Composited CN (AMC 2)		81.2273

Pervious TC Calc						
Type	Description	Length	Slope	Coeff	Misc	TT
Shallow	Short grass, pasture and lawns (n=0.030)	195.00 ft	6.0%	0.03		1.24 min
Sheet	Woods or forest with light underbrush. 0.40	200.00 ft	20.0%	0.4	2.00 in	18.8276 min
Pervious TC						20.0675 min

DCI - CN Calc		
Description	SubArea	Sub cn
Paved curbs and storm sewers	0.20 ac	98.00
DC Composited CN (AMC 2)		98.00

DCI - TC Calc						
Type	Description	Length	Slope	Coeff	Misc	TT
Sheet	Smooth Surfaces. 0.011	30.00 ft	2.0%	0.011	2.00 in	0.585 min
Shallow	Short grass, pasture and lawns (n=0.030)	195.00 ft	6.0%	0.03		1.24 min
Pervious TC						1.8249 min

ROUTEHYD [] THRU [Entry Road Storm System] USING [25 year] AND [TYPE1a.rac] NOTZERO RELATIVE SCS/SBUH

Gravity Analysis using 24 hr duration storm

Reach ID	Area (ac)	Flow (cfs)	Full Q (cfs)	Full ratio	nDepth (ft)	Depth ratio	Size	nVel (ft/s)	fVel (ft/s)	CBasin / Hyd
Bio-Swale	0.90	0.7064	----	0.00	0.1821	----	Ditch	1.0936	-----	Align, H contributing area
Underdrain	0.90	0.7064	1.4564	0.485	0.2456	0.4913	6 in Diam	7.3588	7.4176	
Pipe 003	0.90	0.7064	3.6488	0.1936	0.2983	0.2983	12 in Diam	3.5926	4.6457	
Entry Swale	1.30	0.5483	----	0.00	0.3779	----	Ditch	0.463	-----	Entry Road
Pipe 001	1.30	0.5483	2.7091	0.2024	0.3052	0.3052	12 in Diam	2.7016	3.4493	
Pipe 002	1.30	0.5483	5.5368	0.099	0.2124	0.2124	12 in Diam	4.4998	7.0497	
Pipe 004	2.20	1.2521	3.6488	0.3431	0.4039	0.4039	12 in Diam	4.2128	4.6457	

HGL Analysis

From Node	To Node	HG El (ft)	App (ft)	Bend (ft)	Junct Loss (ft)	Adjusted HG El (ft)	Max El (ft)
							482.4443
MH #2	Stormchamber	482.7213	-----	0.5646	0.0932	483.3791	488.1430
No approach losses at node Bottom of Swale because inverts and/or crowns are offset.							
CB #6	MH #2	483.3971	0.2010	0.2753	-----	483.4714	487.1260
Bottom of Swale	CB #6	484.7679	--na--	--na--	--na--	484.7679	490.0000
Top of Align H	Bottom of Swale	497.1152	--na--	--na--	--na--	497.1152	500.0000
MH #1	MH #2	483.7301	-----	0.0602	-----	483.7903	488.4500
CB #7	MH #1	483.9274	-----	-----	-----	483.9274	487.9000
Entry Swale	CB #7	489.6250	--na--	--na--	--na--	489.6250	492.0000

Conduit Notes

Reach	HW Depth (ft)	HW/D ratio	Q (cfs)	TW Depth (ft)	Dc (ft)	Dn (ft)	Comment
Pipe 004	0.6723	0.6723	1.25	0.4723	0.4723	0.4039	SuperCrit flow, Inlet end controls
Pipe 003	1.3486	1.3486	0.71	1.3306	0.3505	0.2983	Outlet Control
Underdrain	0.7679	1.5358	0.71	1.0124	0.4236	0.2456	SuperCrit flow, Inlet end controls
Bio-Swale	0.1152	na	0.7064	0.1821	0.1152	0.1821	Direct Step Backwater Calc
Pipe 002	0.4121	0.4121	0.55	1.3301	0.3075	0.2124	SuperCrit flow, Inlet end controls
Pipe 001	0.5154	0.5154	0.55	0.4723	0.3075	0.3052	Outlet Control M1 Backwater

