

1 BOWLING PIN ANCHORAGE DETAIL
SCALE: 1/2" = 1'-0"

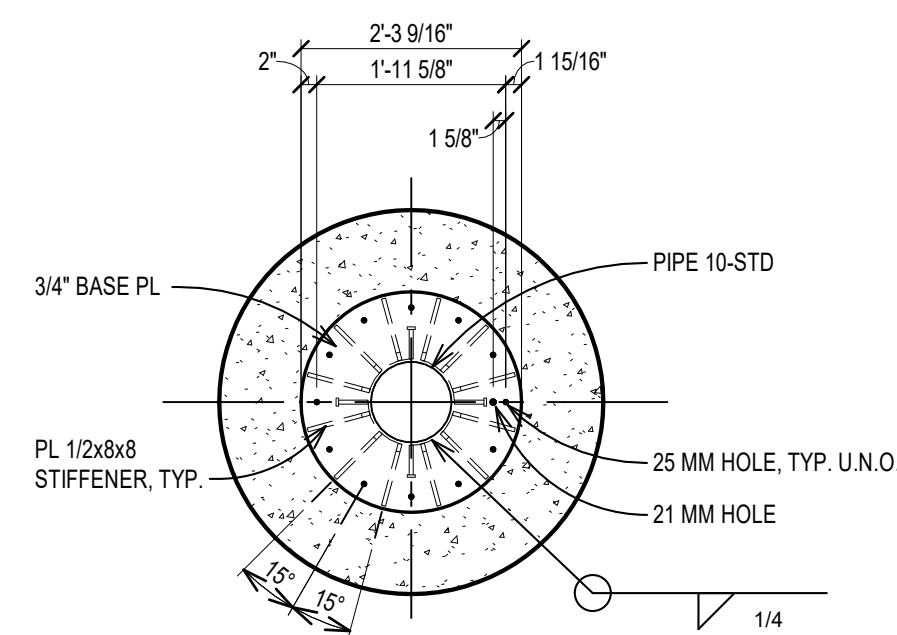

2 BOWLING PIN SECTION
SCALE: 1/2" = 1'-0"

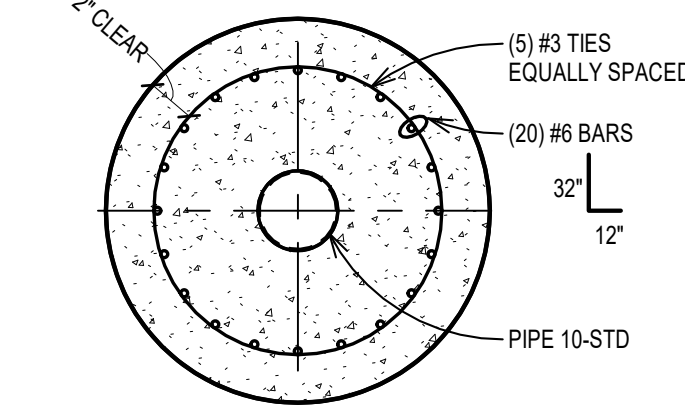

3 BOWLING PIN SECTION
SCALE: 1/2" = 1'-0"

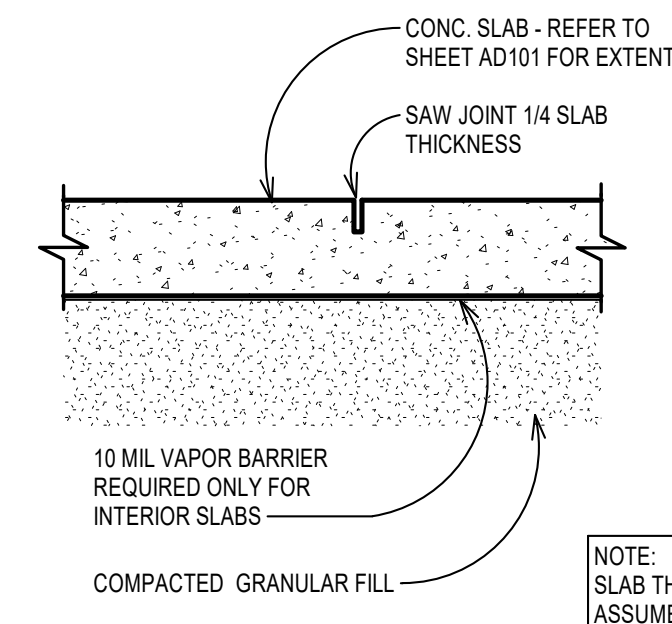

4 CONTROL JOINT
SCALE: 1" = 1'-0"

NOTE: SLAB THICKNESS & REINFORCING TO MATCH EXISTING. ASSUMED 4" EXISTING SLAB THICKNESS

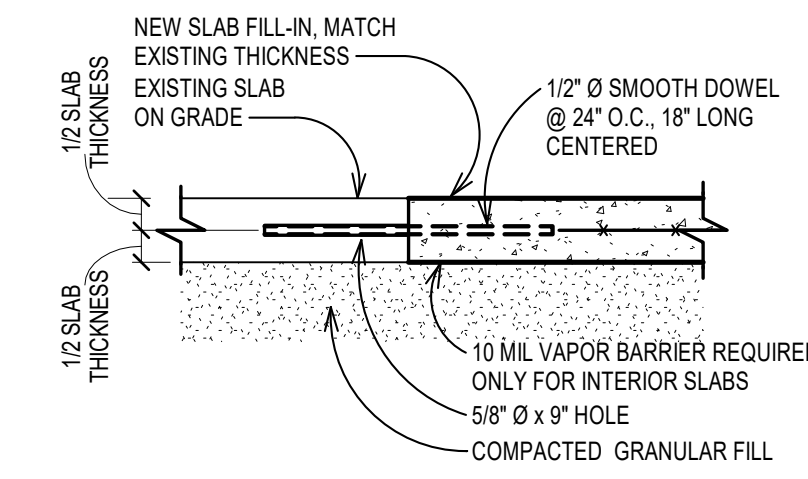

5 SLAB REPAIR DETAIL
SCALE: 1" = 1'-0"

City of Puyallup
Development & Permitting Services
ISSUED PERMIT

Building	Planning
Engineering	Public Works
Fire	Traffic

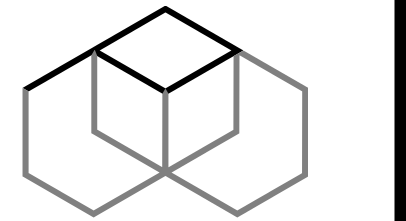

PARADIGM DESIGN
ARCHITECTS | ENGINEERS
415 Leonard Street NW, Suite 200
Grand Rapids, MI 49504
(616) 795-5656
Grand Rapids | Phoenix | Traverse City
www.paradigm-ae.com

FIRM # 603-475-922
EXP. 2/28/2024

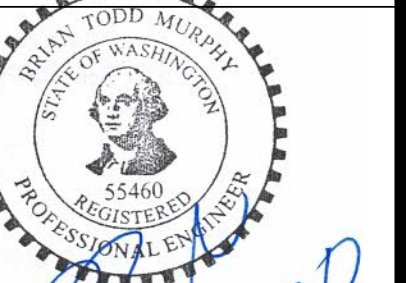

12-10-20

PROJECT

ROUND 1 BOWLING AND AMUSEMENT

SOUTH HILL MALL

TENANT IMPROVEMENT

3500 S. MERIDIEN
PUYALLUP, WA 98373

TENANT

ROUND 1 ENTERTAINMENT

3070 SATURN ST.
STE. 200
BREA, CA 92821

CONSULTANT

STATICS ENGINEERING, PLLC

RELEASE DATE

DATE	DESCRIPTION
12-15-20	PERMITS
7-20-21	BIDS
8-16-21	REVISED FOR PERMITS

PERMITS

BIDS

REVISED FOR PERMITS

PROJECT

1905082GR

SHEET

STRUCTURAL FOUNDATION DETAILS

S-501