

Per Puyallup Municipal Code 17.42.035, Applications shall expire by limitation if no permit or approval is issued within 180 days after the city determines that the application is complete, unless the city determines that a project proponent has pursued issuance of a permit or approval in good faith.

Submittal Date: ____/____/____ Civil Permit No: ____-____-____ Related Case No: ____-____

*Applicant must include this completed form with the initial application submittal.
Submit all documents electronically to: permitcenter@puyallupwa.gov*

Acceptance Criteria Checklist

Applicant		Documents	City Received	
Yes	No		Yes	No
<input type="checkbox"/>		Plan Sheets – electronic submittal only	<input type="checkbox"/>	
<input type="checkbox"/>		Cover Sheet	<input type="checkbox"/>	
<input type="checkbox"/>		Notes and Details	<input type="checkbox"/>	
<input type="checkbox"/>		Existing Conditions	<input type="checkbox"/>	
<input type="checkbox"/>		Erosion and Sediment Control	<input type="checkbox"/>	
<input type="checkbox"/>		Grading	<input type="checkbox"/>	
<input type="checkbox"/>	<input type="checkbox"/>	Road Plan and Profile	<input type="checkbox"/>	
<input type="checkbox"/>		Utility Plans (water, sanitary and storm)	<input type="checkbox"/>	
<input type="checkbox"/>	<input type="checkbox"/>	Street Lighting	<input type="checkbox"/>	
<input type="checkbox"/>	<input type="checkbox"/>	Channelization (i.e. signalization)	<input type="checkbox"/>	
<input type="checkbox"/>	<input type="checkbox"/>	Other: _____	<input type="checkbox"/>	
<input type="checkbox"/>	<input type="checkbox"/>	Landscape Plan	<input type="checkbox"/>	
Technical Information Report (TIR) electronic				
<input type="checkbox"/>	<input type="checkbox"/>	Stormwater Site Plan Report	<input type="checkbox"/>	
<input type="checkbox"/>	<input type="checkbox"/>	Critical Areas Report (If applicable)	<input type="checkbox"/>	
<input type="checkbox"/>	<input type="checkbox"/>	Other: _____	<input type="checkbox"/>	
Water Purveyor				
<input type="checkbox"/>	Fruitland Mutual Water Company			
<input type="checkbox"/>	Tacoma Water			
<input type="checkbox"/>	Valley Water System			
Checked in by : _____				
Date: _____				

Civil Construction Permit Application

OWNER	
Name: _____	Address: _____
Contact No: _____	City: _____
Email: _____	State, Zip: _____
APPLICANT	
Name: _____	Address: _____
Contact No: _____	City: _____
Email: _____	State, Zip: _____
ENGINEER / ARCHITECT	
Name: _____	Address: _____
Contact No: _____	City: _____
Email: _____	State, Zip: _____
CONTRACTOR	
Name: _____	Address: _____
Contact No: _____	City: _____
Email: _____	State, Zip: _____

Site Information

Project Name: _____	P - _____
Site Address: _____	Parcel No: _____
_____	Zoning: _____

Site Information

Project Type:
<input type="checkbox"/> Comercial/ Medical/ Multi- Family
<input type="checkbox"/> Improvements associated with the Building Permit
<input type="checkbox"/> Residential; Single Family/ Duplex
<input type="checkbox"/> Residential Short Plat
<input type="checkbox"/> Residential Subdivision
<input type="checkbox"/> Frontage Improvements
<input type="checkbox"/> Other
Short Plat:
<input type="checkbox"/> Short Plat is recorded
<input type="checkbox"/> Short Plat is not recorded

Review Fees

Plan review and record drawing review fee:	
<input type="checkbox"/> Comercial/ Multi- Family/ Major Plat/Short Plat	\$670.00
<input type="checkbox"/> Off-site, water/ sewer/ storm main extension/ grease interceptor/ oil separator	\$560.00
Plan review plus \$200 record drawing review fee:	
<input type="checkbox"/> Clearing only	\$70.00
<input type="checkbox"/> 0-50 cubic yards	\$130.00
<input type="checkbox"/> 51-100 cubic yards	\$240.00
<input type="checkbox"/> 101-1,000 cubic yards	\$510.00
<input type="checkbox"/> 1,000-10,000 cubic yards	\$760.00
<input type="checkbox"/> 10,001-100,000 cubic yards	\$1,000.00
<input type="checkbox"/> +100,000 cubic yards	\$1,240.00

CERTIFICATION:

I certify that I have read this application and declare that the info contained herein is correct and complete.

Signature of Applicant: _____ Date: _____

4/2021 Print Name: _____



Temp fencing

Gravel fill

Silt fencing

Parking Entrance

50'

100'

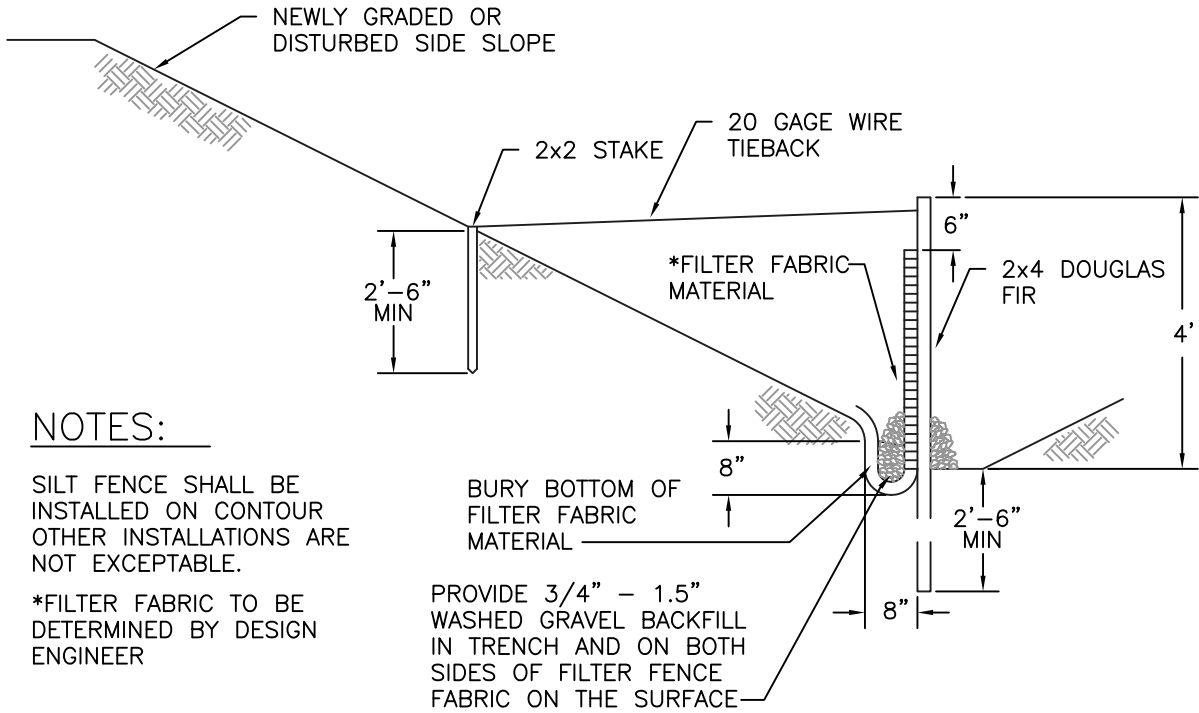

NOTES:

SILT FENCE SHALL BE INSTALLED ON CONTOUR OTHER INSTALLATIONS ARE NOT EXCEPTABLE.
 *FILTER FABRIC TO BE DETERMINED BY DESIGN ENGINEER

PROVIDE 3/4" - 1.5" WASHED GRAVEL BACKFILL IN TRENCH AND ON BOTH SIDES OF FILTER FENCE FABRIC ON THE SURFACE

TYPICAL CROSS SECTION

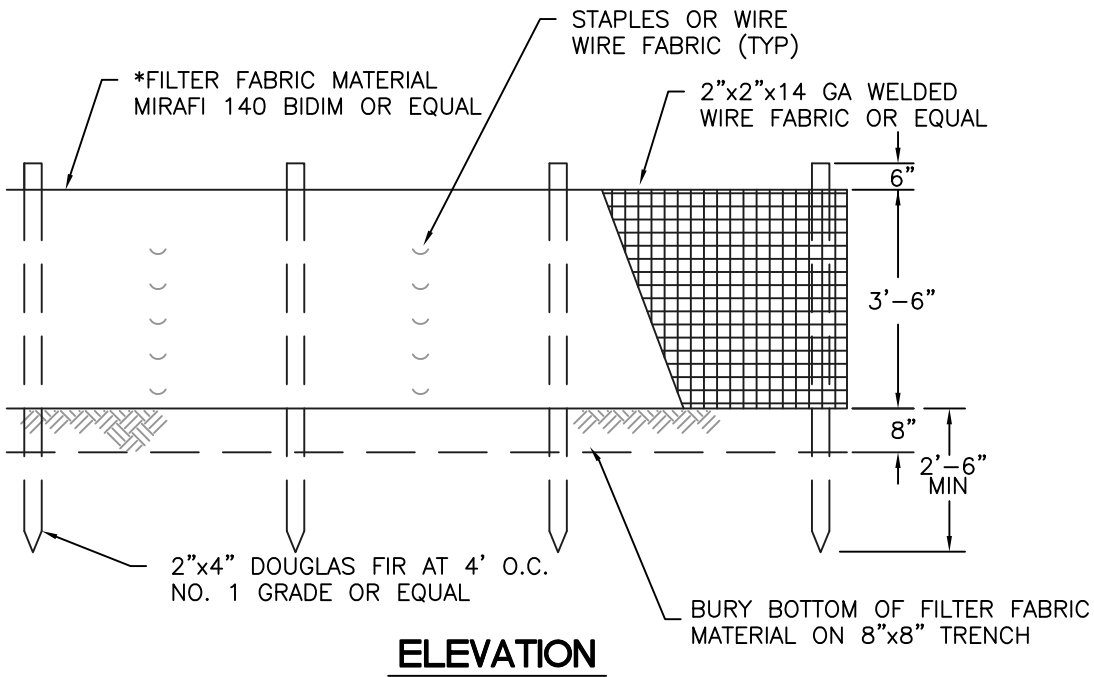

ELEVATION



CITY OF PUYALLUP

DEVELOPMENT ENGINEERING and PUBLIC WORKS DEPARTMENTS

SILTATION FENCE

<small>DRAWN BY</small> LINDA LANSING	<small>CHECKED BY</small> LINDA LIAN	<small>APPROVED BY</small> COLLEEN HARRIS	<small>REVISED BY</small> XXXX	<small>CITY STANDARD</small> 02.03.02
<small>FILE NAME</small> F:\DWG\COMMON\STDS\CITY\2009\02_SD\02.03.02	<small>DATE APPROVED</small> 09/01/1992	<small>DATE REVISED</small> 06/01/2003	<small>SCALE</small> NTS	

NOTE:

1. GEOTEXTILE MIRAFI 500 X OR APPROVED EQUAL SHALL BE PLACED UNDER THE ENTIRETY OF THE TEMPORARY ENTRANCE.
2. ADDITIONAL ROCK SHALL BE ADDED PERIODICALLY TO MAINTAIN PROPER FUNCTION OF THE PAD.
3. IF THE PAD DOES NOT ADEQUATELY REMOVE THE MUD FROM THE VEHICLE'S WHEELS, THE WHEELS SHALL BE HOSED OFF BEFORE THE VEHICLE ENTERS A PAVED STREET. THE WASHING SHALL BE DONE ON AN AREA COVERED WITH CRUSHED ROCK AND WASH WATER SHALL DRAIN TO A SEDIMENT RETENTION FACILITY OR THROUGH A SILT FENCE.

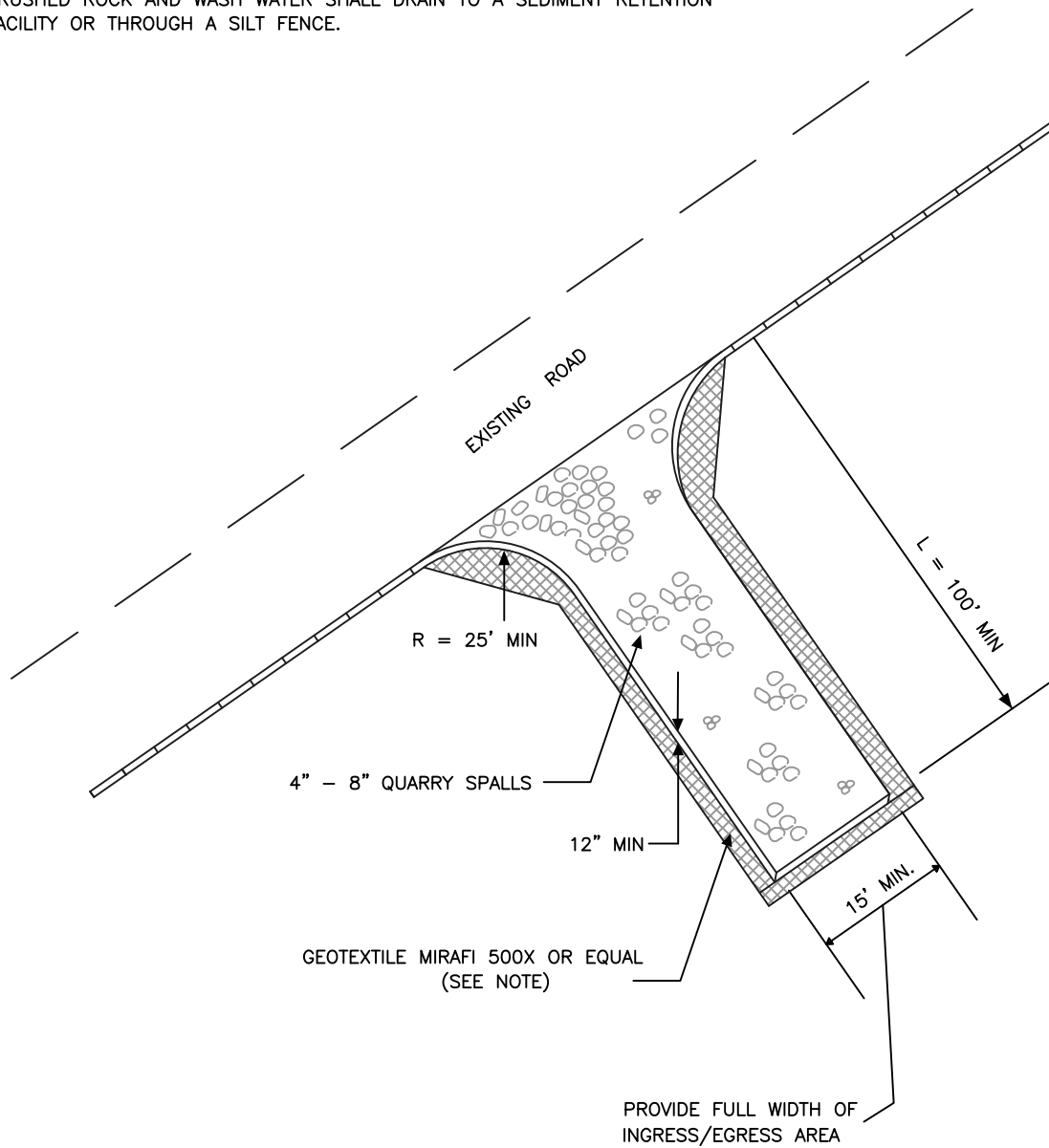

CITY OF PUYALLUP

DEVELOPMENT ENGINEERING and
PUBLIC WORKS DEPARTMENTS

TEMPORARY CONSTRUCTION ENTRANCE

DRAWN BY
JIM ERWIN-SVOBODA

CHECKED BY
LINDA LIAN

APPROVED BY
COLLEEN HARRIS

REVISED BY
XXXX

*CITY
STANDARD*

FILE NAME
F:\DWG\COMMON\STDS\CITY\2009\05_GRD\05.01\05.01.01

DATE APPROVED
07/01/2009

DATE REVISED
XX/XX/XX

SCALE
1:40

05.01.01