

SK-PHOTO-W SERIES

Addressable Photoelectric Smoke Detectors

The Silent Knight® SK-PHOTO-W Series feature a modern design and expanded color options support a variety of contemporary aesthetic demands. In addition, each detector is constructed for exceptional installation and maintenance efficiency.



The SK-PHOTO-W Series intelligent plug-in smoke detectors are designed for both performance and aesthetics, and are direct replacements for the SK-PHOTO Series detectors. A new modern, sleek, contemporary design and enhanced optical sensing chamber is engineered to sense smoke produced by a wide range of combustion sources in accordance with more stringent code standards. The SK-PHOTO-W Series detector sensitivity can be programmed in the control panel software. Sensitivity is continuously monitored and reported to the panel. Point ID capability allows each detector's address to be set with rotary, decimal address switches, providing exact detector location for selective maintenance when chamber contamination reaches an unacceptable level. Dual electronic thermistors add 135°F (57°C) fixed temperature thermal sensing on the SK-PHOTO-T-W. The SK-PHOTO-R-W is a remote test capable detector for use with DNR Series duct detector housings.

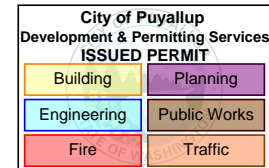

FEATURES AND BENEFITS

- Designed to meet UL 1268 7th Edition
- Sleek and stylish contemporary design
- Stable communication technique with noise immunity
- Addressable by device
- Rotary, decimal addressing (Refer to the Silent Knight panel manuals for device capacity)
- Two-wire SLC connection
- LEDs blink every time the unit is polled
- 360°-field viewing angle of the visual alarm indicators (two bi-color LEDs); LEDs blink green in Normal condition and turn on steady red in Alarm
- Integral communications and built-in device-type identification
- Remote test feature from the panel
- Built-in functional test switch activated by external magnet
- Walk test with address display (an address of 121 will blink the detector LED 12-(pause)-1)
- Low standby current
- Built-in tamper-resistant feature
- Designed for direct-surface or electrical-box mounting
- Sealed against back pressure
- Plugs into separate base for ease of installation and maintenance
- Expanded color options
- SEMS screws for wiring of the separate base
- Optional remote, single-gang LED accessory
- Optional sounder, relay, and isolator bases

INSTALLATION

The SK-PHOTO-W Series plug-in intelligent thermal detectors use a separate base to simplify installation, service, and maintenance. Installation instructions are shipped with each detector.

Mount base (all base types) on an electrical backbox which is at least 1.5" (3.81 cm) deep. For a chart of compatible junction boxes, see SK-61045.

Note: Because of the inherent supervision provided by the SLC loop, end-of-line resistors are not required. Wiring "T-taps" or branches are permitted for Style 4 (Class "B") wiring.

Note: When using relay or sounder bases, consult the SK-ISO installation sheet I56-3627 for device limitations between isolator modules and isolator bases.

OPERATION

Each SK-PHOTO-W Series detector uses one of the panel's addresses (total limit is panel dependent) on the Signaling Line Circuit (SLC). It responds to regular polls from the control panel and reports its type and the status. If it receives a test command from the panel (or a local magnet test), it stimulates its electronics and reports an alarm. It blinks its LEDs when polled and turns the LEDs on when commanded by the panel. The SK-PHOTO-W Series offers features and performance that represent the latest in smoke detector technology.

PRODUCT LINE INFORMATION

Note: "-IV" suffix indicates ivory color.

SK-PHOTO-W: White, low-profile photoelectric sensor

SK-PHOTO-T-W: White, same as SK-PHOTO-W but includes a built-in 135°F (57°C) fixed-temperature thermal device

SK-PHOTO-R-W: White, low-profile intelligent photoelectric sensor, remote test capable, for use with DNR/DNRW

B300-6: White, standard flanged low-profile mounting base

B300-6-BP: Bulk pack of B300-6, package contains 10

B300-6-IV: Ivory, standard flanged low-profile mounting base

B501-WHITE: White, standard European flangeless mounting base

B501-BL: Black, standard European flangeless mounting base

B501-IV: Ivory, standard European flangeless mounting base

B501-WHITE-BP: Bulk pack of B501-WHITE, contains 10

B200S-WH: White, Intelligent, programmable sounder base

B200S-IV: Ivory, Intelligent, programmable sounder base

B200SR-WH: White, Intelligent sounder base for retrofit applications

B200SR-IV: Ivory, Intelligent sounder base for retrofit applications

B200S-LF-WH: White, Low Frequency Intelligent, programmable sounder base

B200S-LF-IV: Ivory, Low Frequency Intelligent, programmable sounder base

B200SR-LF-WH: White, Low Frequency Intelligent sounder base for retrofit applications

B200SR-LF-IV: Ivory, Low Frequency Intelligent sounder base for retrofit applications

B224RB-WH: White, plug-in System Sensor® relay base

B224RB-IV: Ivory, plug-in System Sensor relay base

B224BI-WH: White, plug-in System Sensor isolator detector base

B224BI-IV: Ivory, plug-in System Sensor isolator detector base

ACCESSORIES

TR300: White, replacement flange for B210LP or B300-6 bases

TR300-IV: Ivory, replacement flange for B210LP or B300-6 bases

RA100Z(A): Remote 3 – 32 VDC LED annunciator, mounts to a U.S. single-gang electrical box, for use with B501 and B300-6 bases only

M02-04-00: Test magnet

M02-09-00: Test magnet with telescoping handle

CK300: White, detector color kit, pack of 10

CK300-IV: Ivory, detector color kit, pack of 10

CK300-BL: Black, detector color kit, pack of 10

SK-PHOTO-W SERIES TECHNICAL SPECIFICATIONS

PHYSICAL/ENVIRONMENTAL

Sensitivity:

- UL Applications: 0.5% to 4.0% per foot obscuration.
- ULC Applications: 0.5% to 3.5% per foot obscuration

Size: 2.0" (5.3 cm) high; base determines diameter

- **B300-6:** 6.1" (15.6 cm) diameter
- **B501:** 4" (10.2 cm) diameter

For a complete list of detector bases, see SK-61045.

Shipping weight: 3.4 oz. (95 g)

Operating temperature range:

- SK-PHOTO-W: 32°F to 122°F (0°C to 50°C)
- SK-PHOTO-T-W: 32°F to 100°F (0°C to 38°C)
- SK-PHOTO-R-W installed in a DNR/DNRW: -4°F to 158°F (-20°C to 70°C)

UL/ULC Listed Velocity Range: 0-4000 ft/min. (1219.2 m/min.), suitable for installation in ducts

Relative humidity: 10% – 93% non-condensing

Thermal ratings: fixed-temperature set point 135°F (57°C), rate-of-rise detection 15°F (8.3°C) per minute, high temperature heat 190°F (88°C)

ELECTRICAL SPECIFICATIONS

Voltage range: 15 - 32 volts DC peak

Standby current (max. avg.): 200µA @ 24 VDC (one communication every 5 seconds with LED enabled)

Max current: 4.5 mA @ 24 VDC ("ON")

DETECTOR SPACING AND APPLICATIONS

Silent Knight recommends spacing detectors in compliance with NFPA 72. In low airflow applications with smooth ceiling, space detectors 30 feet (9.1m). For specific information regarding detector spacing, placement, and special applications refer to NFPA 72. A *System Smoke Detector Application Guide*, document A05-1003, is available at www.systemsensor.com.

AGENCY LISTINGS AND APPROVALS

These listings and approvals apply to the modules specified in this document. In some cases, certain modules or applications may not be listed by certain approval agencies, or listing may be in process. *Consult factory for latest listing status.*

- **UL Listed:** S6173
- **FM Approved**
- **CSFM:** 7272-0559:0512

Silent Knight® and System Sensor® are registered trademarks of Honeywell International, Inc.

This document is not intended to be used for installation purposes. We try to keep our product information up-to-date and accurate. We cannot cover all specific applications or anticipate all requirements. All specifications are subject to change without notice.

Country of origin: Mexico



5600 Series Mechanical Heat Detectors

System Sensor's 5600 series mechanical heat detectors offer a low-cost means for property protection against fire, and for non-life-safety installations where smoke detectors are inappropriate.



Features

- Multiple configurations for installations:
 - Single- and dual-circuit models
 - Fixed temp and combination fixed- temp/rate-of-rise 135°F or 194°F ratings.
- Plain housing for residential installations (Model 5601P)
- Easy-to-use terminal screws
- A broad range of back box mounting options:
 - Single gang
 - 3.5" and 4" Octagonal
 - 4" square with square to round plaster ring
- Reversible mounting bracket

Multiple configurations. The 5600 series offers a full-line of configurations to accommodate a broad range of applications. Both single- and dual-circuit models are available for low- and high-temperature ratings with either fixed temperature or combination fixed temperature/rate-of-rise (ROR) activation. The ROR element of the fixed/ROR models is restorable to accommodate field-testing.

Installation flexibility. To satisfy a variety of installation needs, the 5600 series easily mounts to single-gang and octagonal back boxes. And these models accommodate four-square back boxes, when used with a square to round plaster ring. The reversible mounting bracket permits both flush- and surface-mount back box installations.

Visual identification. The 5600 series provides clear markings on the exterior of the unit to ensure that the proper detector is being used. Alphanumeric characters identify the activation method, as well as the temperature rating, in Fahrenheit and Celsius degrees. Fixed temperature models are identified FX, while combination fixed/rate-of-rise units are marked FX/ROR. The 5600 series also provides a post-activation indicator in the form of a collector. When the detector is activated, the collector drops from the unit, making it easy to identify the unit in alarm.

Agency Listings



Specifications

Architectural/Engineering Specifications

Mechanical heat detector shall be a System Sensor 5600 series model number _____, listed to Underwriters Laboratories UL 521 for Heat Detectors for Fire Protective Signaling Systems. The detector shall be either a single-circuit or a dual-circuit type, normally open. The detector shall be rated for activation at either 135°F (57°C) or 194°F (90°C), and shall activate by means of a fixed temperature thermal sensor, or a combination fixed temperature/rate-of-rise thermal sensor. The rate-of-rise element shall be activated by a rapid rise in temperature, approximately 15°F (8.3°C) per minute. The detector shall include a reversible mounting bracket for mounting to 3½-inch and 4-inch octagonal, single gang, and 4-inch square back boxes with a square to round plaster ring. Wiring connections shall be made by means of SEMS screws that shall accommodate 14–22AWG wire. The detector shall contain alphanumeric markings on the exterior of the housing to identify its temperature rating and activation method. The rate-of-rise element of combination fixed temperature/rate-of-rise models shall be restorable, to allow for field-testing. The detectors shall include an external collector that shall drop upon activation to identify the unit in alarm.

Physical/Operating Specifications

Maximum Installation Temperature	5601P, 5603, 5621, and 5623: 100°F (38°C) 5602, 5604, 5622, and 5624: 150°F (65.6°C)
Operating Humidity Range	5 to 95% RH non-condensing
Dimensions with mounting bracket	Diameter: 4.57 inches (11.6cm) Height: 1.69 inches (4.3cm)
Alarm Temperature	5601P, 5603, 5621, and 5623: 135°F (57°C) 5602, 5604, 5622, and 5624: 194°F (90°C)
Weight	6 oz. (170 grams)
Rate-of-Rise Threshold	15°F (8.3°C) rise per minute (models 5601P, 5602, 5621, and 5622 only)
Mounting	3½-inch octagonal back box 4-inch octagonal back box Single gang back box 4-inch square back box with a square to round plaster ring

Electrical Specifications

Operating Voltage / Contact Ratings	6–125VAC / 3A 6–28VDC / 1A 125VDC / 0.3A 250VDC / 0.1A
Input Terminals	14–22 AWG

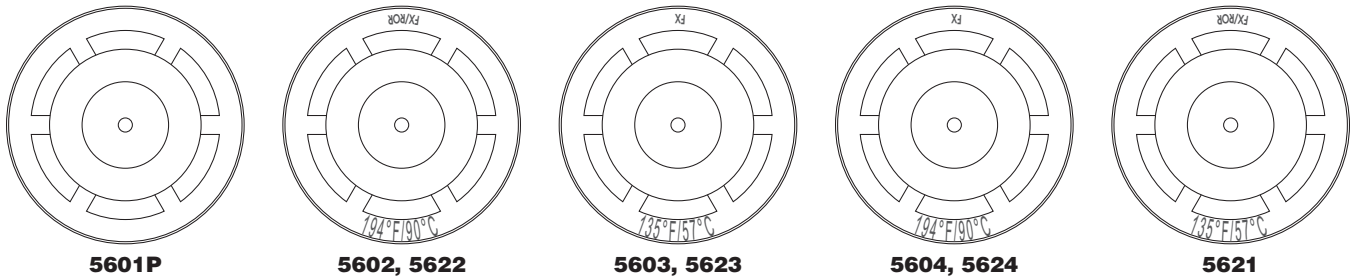

Ordering Information

Model	Circuit	Identification Method on Exterior	Temperature Rating	Activation	UL Protected Spacing – 10 Foot Ceiling*
5601P	Single	None	135°F (57°C)	Fixed Temperature / Rate-of-Rise	50 feet × 50 feet (15.24m × 15.2m)
5602	Single	Lettering	194°F (90°C)	Fixed Temperature / Rate-of-Rise	50 feet × 50 feet (15.24m × 15.2m)
5603	Single	Lettering	135°F (57°C)	Fixed Temperature	25 feet × 25 feet (7.62m × 7.62m)
5604	Single	Lettering	194°F (90°C)	Fixed Temperature	25 feet × 25 feet (7.62m × 7.62m)
5621	Dual	Lettering	135°F (57°C)	Fixed Temperature / Rate-of-Rise	50 feet × 50 feet (15.24m × 15.2m)
5622	Dual	Lettering	194°F (90°C)	Fixed Temperature / Rate-of-Rise	50 feet × 50 feet (15.24m × 15.2m)
5623	Dual	Lettering	135°F (57°C)	Fixed Temperature	25 feet × 25 feet (7.62m × 7.62m)
5624	Dual	Lettering	194°F (90°C)	Fixed Temperature	25 feet × 25 feet (7.62m × 7.62m)

*NOTE: Refer to NFPA72 guidelines for spacing reductions when ceiling heights exceed 10 feet.



3825 Ohio Avenue • St. Charles, IL 60174
Phone: 800-SENSOR2 • Fax: 630-377-6495
www.systemsensor.com

©2013 System Sensor.
Product specifications subject to change without notice. Visit systemsensor.com for current product information, including the latest version of this data sheet.
SPDS30001 • 7/13



Indoor Selectable-Output Strobes and Horn Strobes for Ceiling Applications

System Sensor L-Series audible visible notification products are rich with features guaranteed to cut installation times and maximize profits with lower current draw and modern aesthetics.



Features

- Plug-in design with minimal intrusion into the back box
- Tamper-resistant construction
- Automatic selection of 12- or 24-volt operation at 15 and 30 candela
- Field-selectable candela settings on ceiling units: 15, 30, 75, 95, 115, 150, and 177
- Horn rated at 88+ dBA at 16 volts
- Rotary switch for horn tone and two volume selections
- Universal mounting plate for ceiling units
- Mounting plate shorting spring feature checks wiring continuity before device installation
- Electrically Compatible with legacy SpectrAlert and SpectrAlert Advance devices
- Compatible with MDL3 sync module
- Listed for ceiling mounting only

The System Sensor L-Series offers the most versatile and easy-to-use line of horns, strobes, and horn strobes in the industry with lower current draws and modern aesthetics. With white and red plastic housings, wall and ceiling mounting options, System Sensor L-Series can meet virtually any application requirement.

The entire L-Series product line of ceiling-mount strobes and horn strobes include a variety of features that increase their application versatility while simplifying installation. All devices feature a plug-in design with minimal intrusion into the back box, making installations fast and foolproof while virtually eliminating costly and time-consuming ground faults.

To further simplify installation, the L-Series utilizes a universal mounting plate so installers can mount them to a wide array of back boxes. With an onboard shorting spring, installers can test wiring continuity before the device is installed.

Installers can also easily adapt devices to a suit a wide range of application requirements using field-selectable candela settings, automatic selection of 12- or 24-volt operation, and a rotary switch for horn tones with two volume selections.

Agency Listings



S5512
S4011



FM approved except
for ALERT models
3057383



7125-1653:0504
7135-1653:0503

L-Series Specifications

Architect/Engineer Specifications

General

L-Series ceiling-mount strobes and horn strobes shall mount to a standard 4 × 4 × 1½-inch back box, 4-inch octagon back box, or double-gang back box. Two-wire products shall also mount to a single-gang 2 × 4 × 17/8-inch back box. A universal mounting plate shall be used for mounting ceiling and wall products. The notification appliance circuit wiring shall terminate at the universal mounting plate. Also, L-Series products, when used with the Sync•Circuit™ Module accessory, shall be powered from a non-coded notification appliance circuit output and shall operate on a nominal 12 or 24 volts. When used with the Sync•Circuit Module, 12-volt-rated notification appliance circuit outputs shall operate between 8.5 and 17.5 volts; 24-volt-rated notification appliance circuit outputs shall operate between 16.5 and 33 volts. Indoor L-Series products shall operate between 32 and 120 degrees Fahrenheit from a regulated DC or full-wave rectified unfiltered power supply. Ceiling strobes and horn strobes shall have field-selectable candela settings including 15, 30, 75, 95, 115, 150, and 177.

Strobe

The strobe shall be a System Sensor L-Series Model _____ listed to UL 1971 and shall be approved for fire protective service. The strobe shall be wired as a primary-signaling notification appliance and comply with the Americans with Disabilities Act requirements for visible signaling appliances, flashing at 1 Hz over the strobe's entire operating voltage range. The strobe light shall consist of a xenon flash tube and associated lens/reflector system.

Horn Strobe Combination

The horn strobe shall be a System Sensor L-Series Model _____ listed to UL 1971 and UL 464 and shall be approved for fire protective service. The horn strobe shall be wired as a primary-signaling notification appliance and comply with the Americans with Disabilities Act requirements for visible signaling appliances, flashing at 1 Hz over the strobe's entire operating voltage range. The strobe light shall consist of a xenon flash tube and associated lens/reflector system. The horn shall have two audibility options and an option to switch between a temporal three pattern and a non-temporal (continuous) pattern. These options are set by a multiple position switch. The horn on horn strobe models shall operate on a coded or non-coded power supply.

Synchronization Module

The module shall be a System Sensor Sync•Circuit model MDL3 listed to UL 464 and shall be approved for fire protective service. The module shall synchronize L-Series strobes at 1 Hz and horns at temporal three. Also, while operating the strobes, the module shall silence the horns on horn strobe models over a single pair of wires. The module shall mount to a 4 11/16 × 4 11/16 × 2 1/8-inch back box. The module shall also control two Style Y (class B) circuits or one Style Z (class A) circuit. The module shall synchronize multiple zones. Daisy chaining two or more synchronization modules together will synchronize all the zones they control. The module shall not operate on a coded power supply.

Physical/Electrical Specifications

Standard Operating Temperature	32°F to 120°F (0°C to 49°C)
Humidity Range	10 to 93% non-condensing
Strobe Flash Rate	1 flash per second
Nominal Voltage	Regulated 12 VDC or regulated 24 DC/FWR ¹
Operating Voltage Range²	8 to 17.5 V (12 V nominal) or 16 to 33 V (24 V nominal)
Operating Voltage Range (MDL3)	8.5 to 17.5V (12 V nominal) or 16.5 to 33 V (24V nominal)
Input Terminal Wire Gauge	12 to 18 AWG
Ceiling-Mount Dimensions (including lens)	6.8" diameter × 2.5" high (173 mm diameter × 64 mm high)
Ceiling-Mount Surface Mount Back Box Skirt Dimensions (SBBCRL, SBBCWL)	6.9" diameter × 3.4" high (175 mm diameter × 86 mm high)

Notes:

1. Full Wave Rectified (FWR) voltage is a non-regulated, time-varying power source that is used on some power supply and panel outputs.
2. P, S, PC, and SC products will operate at 12 V nominal only for 15 and 30 cd.

UL Current Draw Data

UL Max. Strobe Current Draw (mA RMS)				
Candela Range	Candela	8–17.5 Volts		16–33 Volts
		DC	DC	FWR
Candela Range	15	87	41	60
	30	153	63	86
	75	N/A	111	142
	95	N/A	134	164
	115	N/A	158	191
	150	N/A	189	228
	177	N/A	226	264

UL Max. Horn Current Draw (mA RMS)				
Sound Pattern	dB	8–17.5 Volts		16–33 Volts
		DC	DC	FWR
Temporal	High	39	44	54
Temporal	Low	28	32	54
Non-Temporal	High	43	47	54
Non-Temporal	Low	29	32	54
3.1 KHz Temporal	High	39	41	54
3.1 KHz Temporal	Low	29	32	54
3.1 KHz Non-Temporal	High	42	43	54
3.1 KHz Non-Temporal	Low	28	29	54
Coded	High	43	47	54
3.1 KHz Coded	High	42	43	54

UL Max. Current Draw (mA RMS), Ceiling Horn Strobe, Candela Range (15–177 cd)										
DC Input	8–17.5 Volts		16–33 Volts							
	15cd	30cd	15cd	30cd	75cd	95cd	115cd	150cd	177cd	
Temporal High	103	167	71	90	143	165	187	217	254	
Temporal Low	96	165	54	71	137	161	185	211	249	
Non-Temporal High	106	173	71	90	141	165	187	230	273	
Non-Temporal Low	95	166	54	71	124	161	170	216	258	
3.1K Temporal High	111	164	69	94	147	163	184	229	257	
3.1K Temporal Low	103	163	54	88	143	155	185	212	252	
3.1K Non-Temporal High	111	172	69	94	144	164	202	229	271	
3.1K Non-Temporal Low	103	169	54	88	131	155	187	217	259	
FWR Input	16–33 Volts									
	15cd	30cd	75cd	95cd	115cd	150cd	177cd			
Temporal High	107	135	179	198	223	254	286			
Temporal Low	78	101	151	172	199	229	262			
Non-Temporal High	107	135	179	198	223	254	286			
Non-Temporal Low	78	101	151	172	199	229	262			
3.1K Temporal High	108	135	179	200	225	255	289			
3.1K Temporal Low	79	101	150	171	196	229	260			
3.1K Non-Temporal High	108	135	179	200	225	255	289			
3.1K Non-Temporal Low	79	101	150	171	196	229	260			

Horn Strobe Tones and Sound Output Data

Horn Strobe Output (dBA)					
Switch Position	Sound Pattern	dB	8–17.5 Volts	16–33 Volts	FWR
			DC	DC	
1	Temporal	High	84	89	89
2	Temporal	Low	75	83	83
3	Non-Temporal	High	85	90	90
4	Non-Temporal	Low	76	84	84
5	3.1 KHz Temporal	High	83	88	88
6	3.1 KHz Temporal	Low	76	82	82
7	3.1 KHz Non-Temporal	High	84	89	89
8	3.1 KHz Non-Temporal	Low	77	83	83

L-Series Dimensions

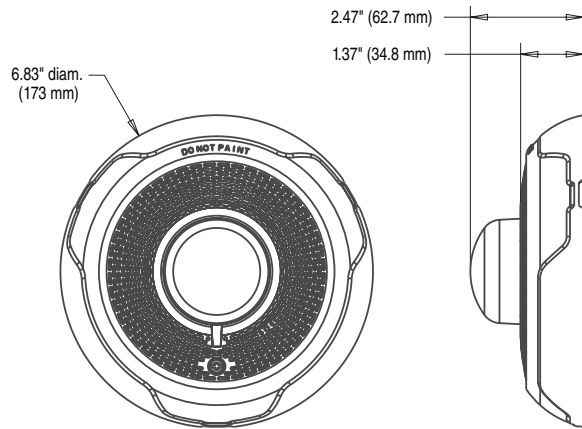

Ceiling-Mount Horn Strobes

A0545-00

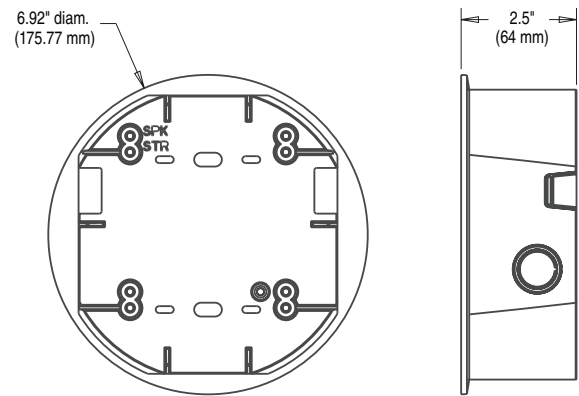

Ceiling Surface Mount Back Box

A0546-00

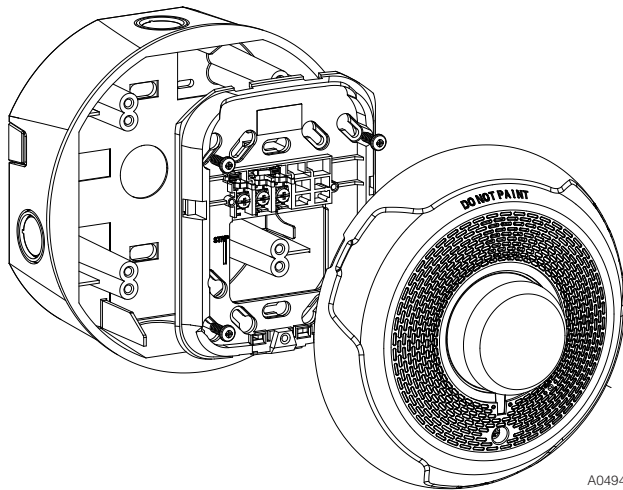

**2-Wire Ceiling Mount Horn Strobes
with Ceiling Surface Mount Back Box**

A0494-01

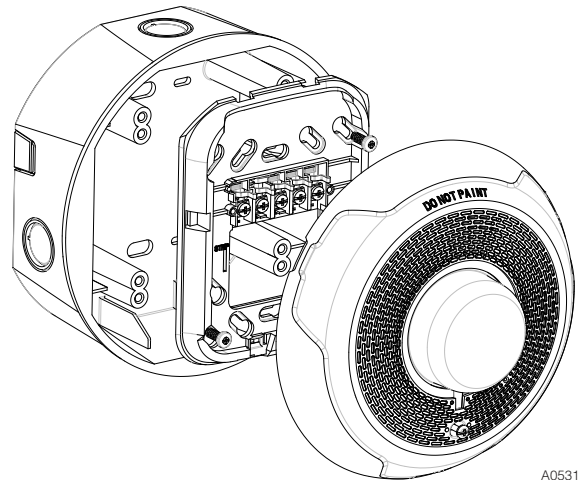

**4-Wire Ceiling Mount Horn Strobes
with Ceiling Surface Mount Back Box**

A0531-01

L-Series Ordering Information

Model	Description
Ceiling Horn Strobes	
PC2RL	2-Wire, Horn Strobe, Red
PC2WL	2-Wire, Horn Strobe, White
PC4RL	4-Wire, Horn Strobe, Red
PC4WL	4-Wire, Horn Strobe, White

Model	Description
Ceiling Strobes	
SCRL	Strobe, Red
SCWL	Strobe, White
SCWL-CLR-ALERT	Strobe, White, ALERT
Accessories	
TRC-2	Universal Ceiling Trim Ring Red
TRC-2W	Universal Ceiling Trim Ring White
SBBCRL	Ceiling Surface Mount Back Box, Red
SBBCWL	Ceiling Surface Mount Back Box, White

For a ceiling-listed horn-only device, see AVDS865 "Indoor Selectable-Output Horns, Strobes, and Horn Strobes for Wall Applications".



3825 Ohio Avenue • St. Charles, IL 60174
Phone: 800-SENSOR2 • Fax: 630-377-6495

©2017 System Sensor.
Product specifications subject to change without notice. Visit systemsensor.com
for current product information, including the latest version of this data sheet.
AVDS868-02 • 12/01/2017



Indoor Selectable-Output Horns, Strobes, and Horn Strobes for Wall Applications

System Sensor L-Series audible visible notification products are rich with features guaranteed to cut installation times and maximize profits with lower current draw and modern aesthetics.

Features

- Updated Modern Aesthetics
- Small profile devices for Horns and Horn Strobes
- Plug-in design with minimal intrusion into the back box
- Tamper-resistant construction
- Automatic selection of 12- or 24-volt operation at 15 and 30 candela
- Field-selectable candela settings on wall units: 15, 30, 75, 95, 110, 135, and 185
- Horn rated at 88+ dBA at 16 volts
- Rotary switch for horn tone and two volume selections
- Mounting plate for all standard and all compact wall units
- Mounting plate shorting spring checks wiring continuity before device installation
- Electrically Compatible with legacy SpectrAlert and SpectAlert Advance devices
- Compatible with MDL3 sync module
- Listed for wall mounting only

Agency Listings



The System Sensor L-Series offers the most versatile and easy-to-use line of horns, strobes, and horn strobes in the industry with lower current draws and modern aesthetics. With white and red plastic housings, standard and compact devices, and plain, FIRE, and FUEGO-printed devices, System Sensor L-Series can meet virtually any application requirement.

The L-Series line of wall-mount horns, strobes, and horn strobes include a variety of features that increase their application versatility while simplifying installation. All devices feature plug-in designs with minimal intrusion into the back box, making installations fast and foolproof while virtually eliminating costly and time-consuming ground faults.

To further simplify installation and protect devices from construction damage, the L-Series utilizes a universal mounting plate for all models with an onboard shorting spring, so installers can test wiring continuity before the device is installed.

Installers can also easily adapt devices to a suit a wide range of application requirements using field-selectable candela settings, automatic selection of 12- or 24-volt operation, and a rotary switch for horn tones with two volume selections.

L-Series Specifications

Architect/Engineer Specifications

General

L-Series standard horns, strobes, and horn strobes shall mount to a standard 2 x 4 x 1 7/8-inch back box, 4 x 4 x 1 1/2-inch back box, 4-inch octagon back box, or double-gang back box. L-Series compact products shall mount to a single-gang 2 x 4 x 1 7/8-inch back box. A universal mounting plate shall be used for mounting ceiling and wall products for all standard models and a separate universal mounting plate shall be used for mounting wall compact models. The notification appliance circuit wiring shall terminate at the universal mounting plate. Also, L-Series products, when used with the Sync•Circuit™ Module accessory, shall be powered from a non-coded notification appliance circuit output and shall operate on a nominal 12 or 24 volts. When used with the Sync•Circuit Module, 12-volt-rated notification appliance circuit outputs shall operate between 8.5 and 17.5 volts; 24-volt-rated notification appliance circuit outputs shall operate between 16.5 and 33 volts. Indoor L-Series products shall operate between 32 and 120 degrees Fahrenheit from a regulated DC or full-wave rectified unfiltered power supply. Strobes and horn strobes shall have field-selectable candela settings including 15, 30, 75, 95, 110, 135, and 185.

Strobe

The strobe shall be a System Sensor L-Series Model _____ listed to UL 1971 and shall be approved for fire protective service. The strobe shall be wired as a primary-signaling notification appliance and comply with the Americans with Disabilities Act requirements for visible signaling appliances, flashing at 1 Hz over the strobe's entire operating voltage range. The strobe light shall consist of a xenon flash tube and associated lens/reflector system.

Horn Strobe Combination

The horn strobe shall be a System Sensor L-Series Model _____ listed to UL 1971 and UL 464 and shall be approved for fire protective service. The horn strobe shall be wired as a primary-signaling notification appliance and comply with the Americans with Disabilities Act requirements for visible signaling appliances, flashing at 1 Hz over the strobe's entire operating voltage range. The strobe light shall consist of a xenon flash tube and associated lens/reflector system. The horn shall have two audibility options and an option to switch between a temporal three pattern and a non-temporal (continuous) pattern. These options are set by a multiple position switch. The horn on horn strobe models shall operate on a coded or non-coded power supply.

Synchronization Module

The module shall be a System Sensor Sync•Circuit model MDL3 listed to UL 464 and shall be approved for fire protective service. The module shall synchronize SpectraAlert strobes at 1 Hz and horns at temporal three. Also, while operating the strobes, the module shall silence the horns on horn strobe models over a single pair of wires. The module shall mount to a 4 1/16 x 4 1/16 x 2 1/8-inch back box. The module shall also control two Style Y (class B) circuits or one Style Z (class A) circuit. The module shall synchronize multiple zones. Daisy chaining two or more synchronization modules together will synchronize all the zones they control. The module shall not operate on a coded power supply.

Physical/Electrical Specifications

Standard Operating Temperature	32°F to 120°F (0°C to 49°C)
Humidity Range	10 to 93% non-condensing
Strobe Flash Rate	1 flash per second
Nominal Voltage	Regulated 12 DC or regulated 24 DC/FWR ^{1,2}
Operating Voltage Range	8 to 17.5 V (12 V nominal) or 16 to 33 V (24 V nominal)
Operating Voltage Range MDL3 Sync Module	8.5 to 17.5 V (12 V nominal) or 16.5 to 33 V (24 V nominal)
Input Terminal Wire Gauge	12 to 18 AWG
Wall-Mount Dimensions (including lens)	5.6" L x 4.7" W x 1.91" D (143 mm L x 119 mm W x 49 mm D)
Compact Wall-Mount Dimensions (including lens)	5.26" L x 3.46" W x 1.91" D (133 mm L x 88 mm W x 49 mm D)
Horn Dimensions	5.6" L x 4.7" W x 1.25" D (143 mm L x 119 mm W x 32 mm D)
Compact Horn Dimensions	5.25" L x 3.45" W x 1.25" D (133mm L x 88mm W x 32mm D)

1. Full Wave Rectified (FWR) voltage is a non-regulated, time-varying power source that is used on some power supply and panel outputs.

2. Strobe products will operate at 12 V nominal only for 15 cd and 30 cd.

UL Current Draw Data

UL Max. Strobe Current Draw (mA RMS)				
Candela Range	Candela	8-17.5 Volts		
		DC	16-33 Volts DC	FWR
Candela Range	15	88	43	60
	30	143	63	83
	75	N/A	107	136
	95	N/A	121	155
	110	N/A	148	179
	135	N/A	172	209
	185	N/A	222	257

UL Max. Horn Current Draw (mA RMS)				
Sound Pattern	dB	8-17.5 Volts		
		DC	16-33 Volts DC	FWR
Temporal	High	39	44	54
Temporal	Low	28	32	54
Non-Temporal	High	43	47	54
Non-Temporal	Low	29	32	54
3.1 KHz Temporal	High	39	41	54
3.1 KHz Temporal	Low	29	32	54
3.1 KHz Non-Temporal	High	42	43	54
3.1 KHz Non-Temporal	Low	28	29	54
Coded	High	43	47	54
3.1 KHz Coded	High	42	43	54

UL Max. Current Draw (mA RMS), 2-Wire Horn Strobe, Candela Range (15-115 cd)										
DC Input	8-17.5 Volts		16-33 Volts							
	15cd	30cd	15cd	30cd	75cd	95cd	110cd	135cd	185cd	
Temporal High	98	158	54	74	121	142	162	196	245	
Temporal Low	93	154	44	65	111	133	157	184	235	
Non-Temporal High	106	166	73	94	139	160	182	211	262	
Non-Temporal Low	93	156	51	71	119	139	162	190	239	
3.1K Temporal High	93	156	53	73	119	140	164	190	242	
3.1K Temporal Low	91	154	45	66	112	133	160	185	235	
3.1K Non-Temporal High	99	162	69	90	135	157	175	208	261	
3.1K Non-Temporal Low	93	156	52	72	119	138	162	192	242	
FWR Input	16-33 Volts									
	15cd	30cd	75cd	95cd	110cd	135cd	185cd			
Temporal High	83	107	156	177	198	234	287			
Temporal Low	68	91	145	165	185	223	271			
Non-Temporal High	111	135	185	207	230	264	316			
Non-Temporal Low	79	104	157	175	197	235	283			
3.1K Temporal High	81	105	155	177	196	234	284			
3.1K Temporal Low	68	90	145	166	186	222	276			
3.1K Non-Temporal High	104	131	177	204	230	264	326			
3.1K Non-Temporal Low	77	102	156	177	199	234	291			

Horn Tones and Sound Output Data

Horn and Horn Strobe Output (dBA)					
Switch Position	Sound Pattern	dB	8-17.5 Volts		16-33 Volts
			DC	DC	FWR
1	Temporal	High	84	89	89
2	Temporal	Low	75	83	83
3	Non-Temporal	High	85	90	90
4	Non-Temporal	Low	76	84	84
5	3.1 KHz Temporal	High	83	88	88
6	3.1 KHz Temporal	Low	76	82	82
7	3.1 KHz Non-Temporal	High	84	89	89
8	3.1 KHz Non-Temporal	Low	77	83	83
9*	Coded	High	85	90	90
10*	3.1 KHz Coded	High	84	89	89

* Settings 9 and 10 are not available on the 2-wire horn strobes.

L-Series Dimensions

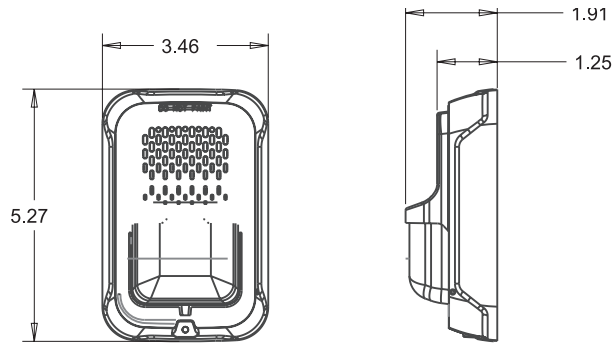

Compact Strobe / Horn Strobe

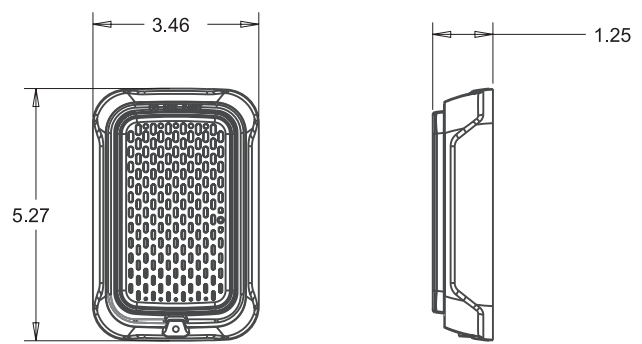

Compact Horn

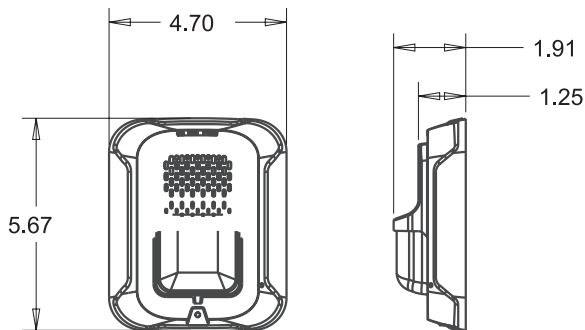

Strobe / Horn Strobe

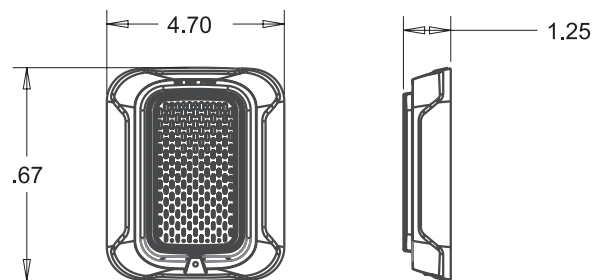

Horn

L-Series Ordering Information

Model	Description
Wall Horn Strobes	
P2RL	2-Wire, Horn Strobe, Red
P2WL	2-Wire, Horn Strobe, White
P2GRL	2-Wire, Compact Horn Strobe, Red
P2GWL	2-Wire, Compact Horn Strobe, White
P2RL-P	2-Wire, Horn Strobe, Red, Plain
P2WL-P	2-Wire, Horn Strobe, White, Plain
P2RL-SP	2-Wire, Horn Strobe, Red, FUEGO
P2WL-SP	2-Wire, Horn Strobe, White, FUEGO
Wall Strobes	
SRL	Strobe, Red
SWL	Strobe, White
SGRL	Compact Strobe, Red
SGWL	Compact Strobe, White
SRL-P	Strobe, Red, Plain
SWL-P	Strobe, White, Plain
SRL-SP	Strobe, Red, FUEGO
SWL-CLR-ALERT	Strobe, White, ALERT

Model	Description
Horns	
HRL	Horn, Red
HWL	Horn, White
HGRL	Compact Horn, Red
HGWL	Compact Horn, White
Accessories	
TR-2	Universal Wall Trim Ring Red
TR-2W	Universal Wall Trim Ring White
SBBRL	Wall Surface Mount Back Box, Red
SBBWL	Wall Surface Mount Back Box, White
SBBGRL	Compact Wall Surface Mount Back Box, Red
SBBGWL	Compact Wall Surface Mount Back Box, White

Notes:

- All -P models have a plain housing (no "FIRE" marking on cover)
- All -SP models have "FUEGO" marking on cover
- All -ALERT models have "ALERT" marking on cover



3825 Ohio Avenue • St. Charles, IL 60174
 Phone: 800-SENSOR2 • Fax: 630-377-6495
www.systemsensor.com

©2017 System Sensor.
 Product specifications subject to change without notice. Visit systemsensor.com
 for current product information, including the latest version of this data sheet.
 AVDS86503 • 03/17