

PRMH20221388



Operation & Installation Manual

THE APPROVED CONSTRUCTION PLANS, DOCUMENTS AND ALL ENGINEERING MUST BE POSTED ON THE JOB AT ALL INSPECTIONS IN A VISIBLE AND READILY ACCESSIBLE LOCATION.

MODEL RSC Remote REFRIGERATED SHOWCASE

FULL SIZED LEDGIBLE COLOR PLANS ARE REQUIRED TO BE PROVIDED BY THE PERMITEE ON SITE FOR INSPECTION

City of Puyallup Development & Permitting Services ISSUED PERMIT	
Building	Planning
Engineering	Public Works
Fire	Traffic





The RSC refrigerated display showcase units have been safety and performance-test approved by Intertek, a safety regulatory testing agency. In the course of new installations or periodic inspections, reference to agency approvals may be required. The regulatory agency file number is listed below and at the bottom of the Specification table on page 5.

ETL File #4007858



Intertek



Intertek



CONTENTS

DIMENSIONS RSC 6	4
SPECIFICATIONS RSC 6	5
DIMENSIONS RSC 4	6
SPECIFICATIONS RSC 4	7
DIMENSIONS RSC 3	8
SPECIFICATIONS RSC 3	9
SAFETY PRECAUTIONS	10
UNPACKING	11
INITIAL SET-UP	12 – 17
Cabinet Set-up.....	12 – 17
ELECTRICAL INSTALLATION	18 - 19
Wiring Diagram.....	19
REFRIGERATION INSTALLATION	20 – 21
VALANCE INSTALLATION	21 – 22
START-UP & OPERATING INFORMATION	23 – 24
Start-up Information and Performance Evaluation.....	23
Operating Guidelines.....	23
Controller Operation and Error Codes.....	24
GENERAL MAINTENANCE	25 – 29
Cleaning the Honeycomb.....	25 – 26
Cleaning the Filter.....	27 – 28
Cleaning the Bottom of the Inner Box & the Drain.....	28
Cleaning the Cabinet.....	29
STORING THE CABINET	29
TROUBLESHOOTING	29 – 30
SERVICE PARTS	31

DIMENSIONS RSC 6

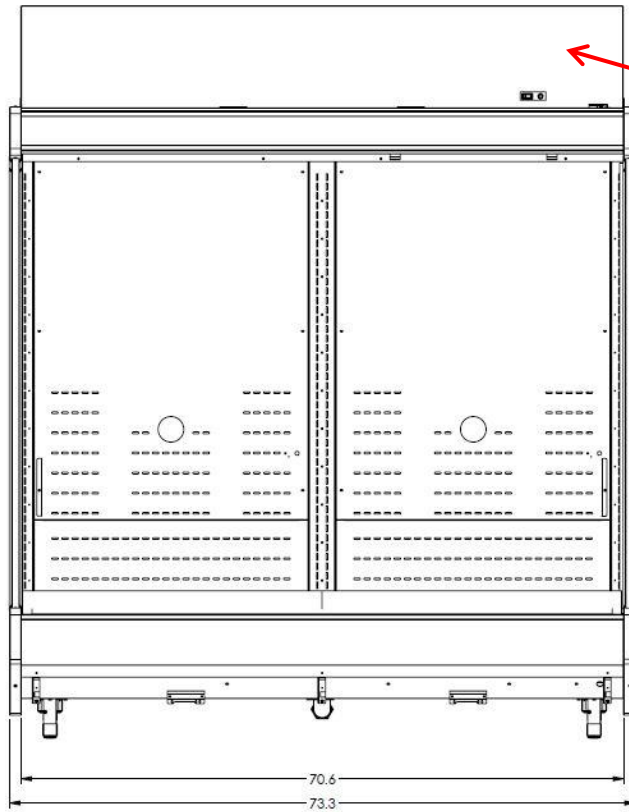

Top Valence Cover adds 16.0" to overall height

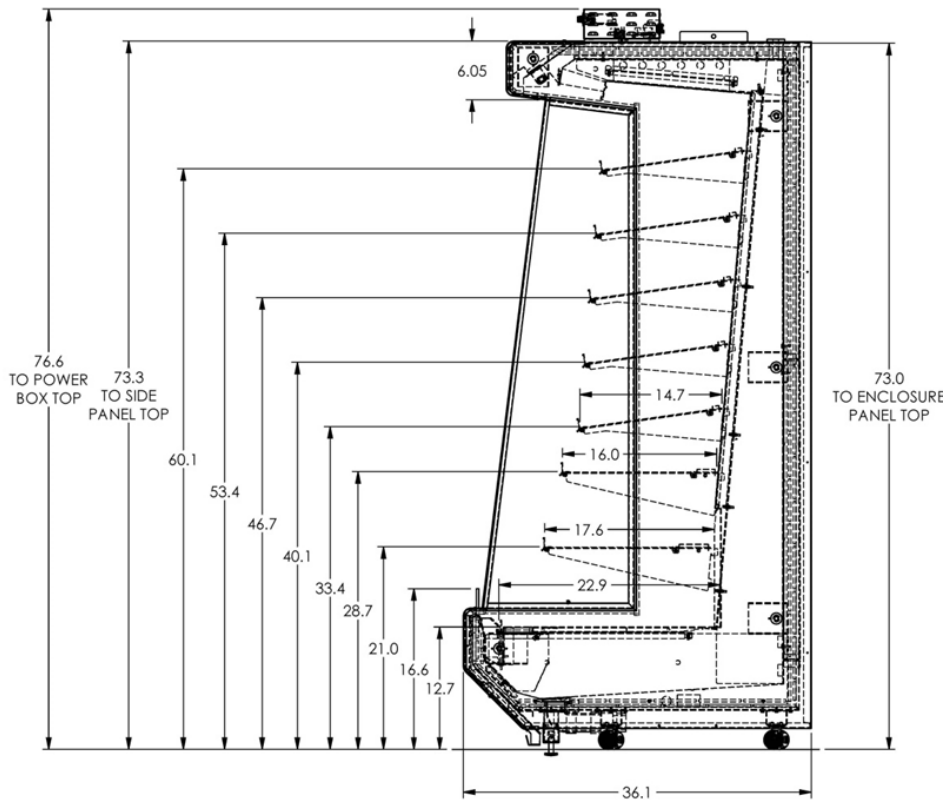



SPECIFICATIONS RSC 6

Model		RSC6 (RAC)
Product Temperature		Maintain product temperature at or below 41°F
Environmental Conditions		NSF/ANSI 7 Type II Standard, maximum indoor 80°F, relative humidity 54%
External Dimensions	Width	73.5"
	Depth	36.1"
	Height	75.6" (91.6" with Valence)
Structure	Outer / Inner Box	Powder coated steel / zinc coated steel
	Insulation	Rigid insulating foam
Color		Internal: Black, External: Black (<i>Optional: White/White available</i>)
Shelves		14 shelves (7 per side), adjustable powder coated steel frame, glass inserts standard (<i>Optional: metal inserts</i>)
Electrical Parts 115/60/1 (3 Amp)	Fan Motor	ECM high efficiency
	Lighting	LED
	Solenoid Valve	Hermetic direct acting solenoid valve for refrigeration (24V DC)
Pipe Size of Connection Point	Liquid Line	3/8" OD
	Suction Line	5/8" OD
Refrigerant		R404A standard (<i>Optional: R410A</i>)
Evaporator		Fin tube type
Expansion Valve		External equalized automatic thermal expansion valve
Controller		Digital programmable controller with Modbus communication protocol
Casters		(4) 2" Casters
Drain Pipe Dimensions		1.5" NPT Male Connector
Thermometer		Product simulation thermometer
Internal Volume		41.46 ft ³
Weight		598 lb.
Noise		Less than 65 dB at 4 ft.
Agency Approvals		ETL File #4007858 Conforms to ANSI/UL 471, NSF Conforms to ANSI Std 7 Type II

NOTE: The manufacturer reserves the right to make product improvements and change specifications without notice



DIMENSIONS RSC 4

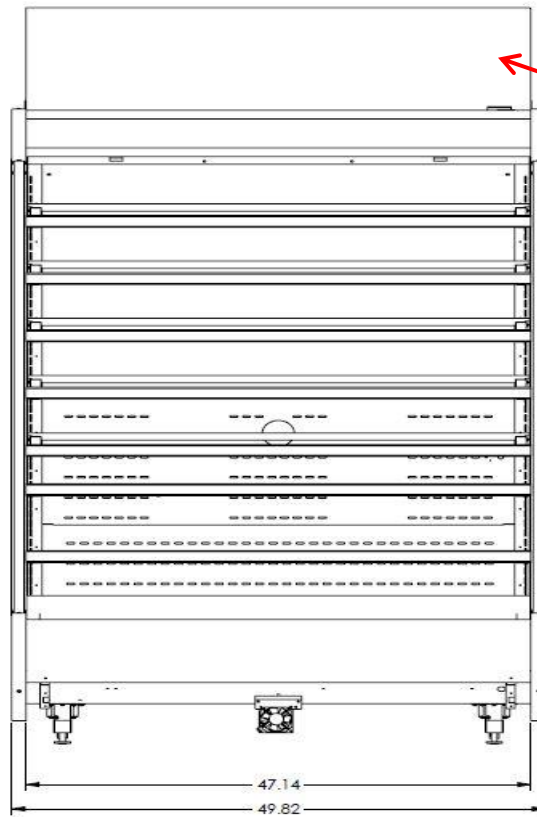

Top Valence Cover adds 16.0" to overall height

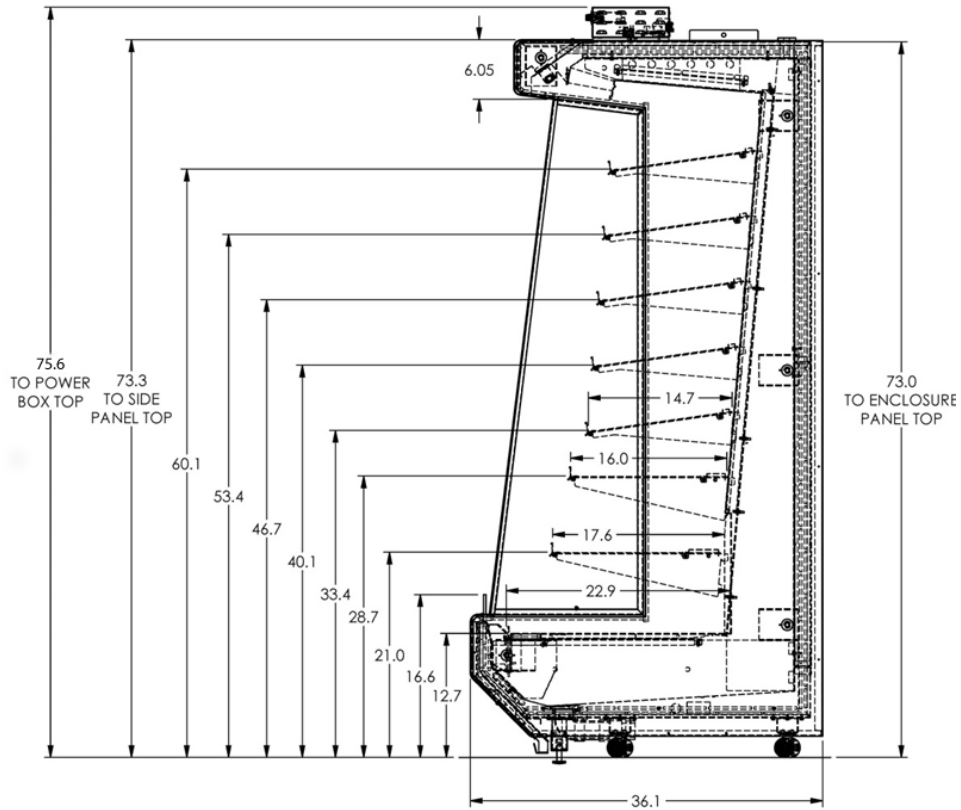



SPECIFICATIONS RSC 4

Model		RSC4 (RAC)
Product Temperature		Maintain product temperature at or below 41°F
Environmental Conditions		NSF/ANSI 7 Type II Standard, maximum indoor 80°F, relative humidity 54%
External Dimensions	Width	49.9"
	Depth	36.1"
	Height	75.6" (91.6" with Valence)
Structure	Outer / Inner Box	Powder coated steel / zinc coated steel
	Insulation	Rigid insulating foam
Color		Internal: Black, External: Black (<i>Optional: White/White available</i>)
Shelves		7 shelves, adjustable powder coated steel frame, glass inserts standard (<i>Optional: metal inserts</i>)
Electrical Parts 115/60/1 (3 Amp)	Fan Motor	ECM high efficiency
	Lighting	LED
	Solenoid Valve	Hermetic direct acting solenoid valve for refrigeration (24V DC)
Pipe Size of Connection Point	Liquid Line	3/8" OD
	Suction Line	5/8" OD
Refrigerant		R404A standard (<i>Optional: R410A</i>)
Evaporator		Fin tube type
Expansion Valve		External equalized automatic thermal expansion valve
Controller		Digital programmable controller with Modbus communication protocol
Casters		(4) 2" Casters
Drain Pipe Dimensions		1.5" NPT Male Connector
Thermometer		Product simulation thermometer
Internal Volume		27.75 ft ³
Weight		405 lb.
Noise		Less than 65 dB at 4 ft.
Agency Approvals		ETL File #4007858 Conforms to ANSI/UL 471, NSF Conforms to ANSI Std 7 Type II

NOTE: The manufacturer reserves the right to make product improvements and change specifications without notice

DIMENSIONS RSC 3

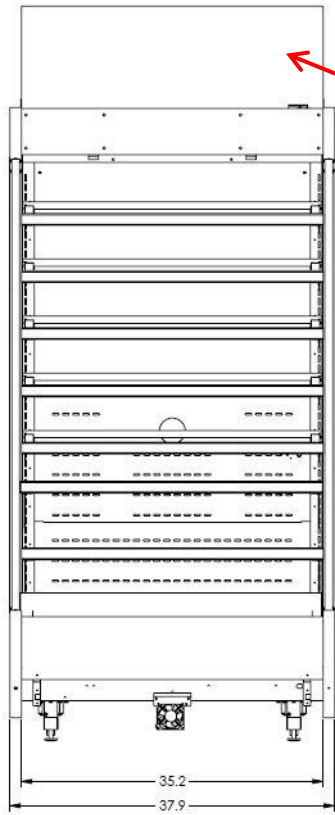

Top Valence Cover adds 16.0" to overall height

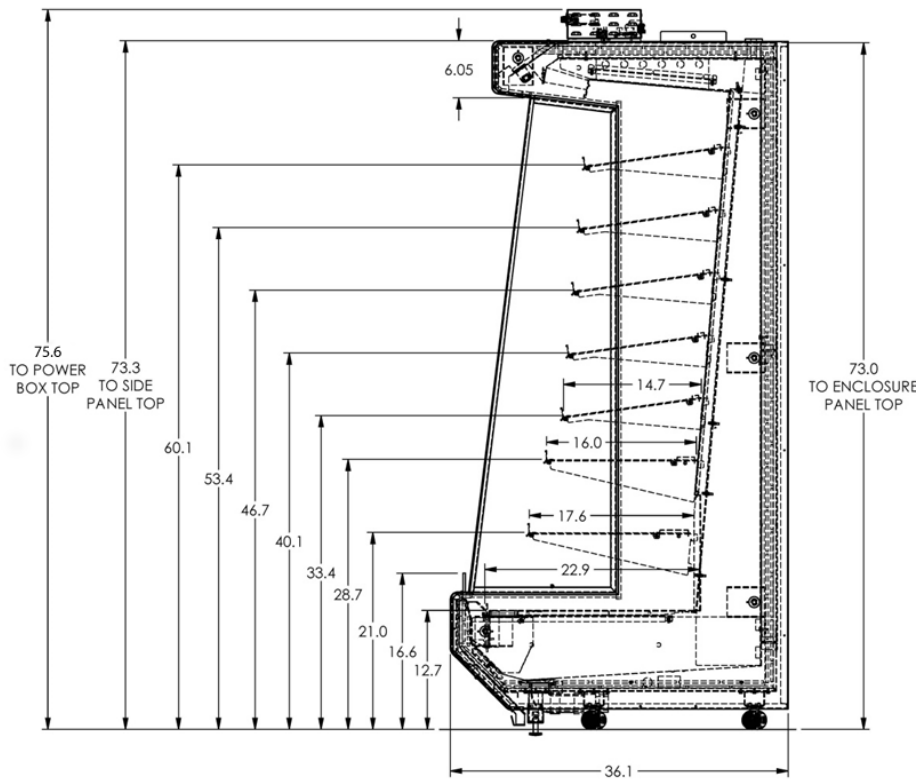



SPECIFICATIONS RSC 3

Model		RSC3 (RAC)
Product Temperature		Maintain product temperature at or below 41°F
Environmental Conditions		NSF/ANSI 7 Type II Standard, maximum indoor 80°F, relative humidity 54%
External Dimensions	Width	37.9"
	Depth	36.1"
	Height	75.6" (91.6" with Valence)
Structure	Outer / Inner Box	Powder coated steel / zinc coated steel
	Insulation	Rigid insulating foam
Color		Internal: Black, External: Black (<i>Optional: White/White available</i>)
Shelves		7 shelves, adjustable powder coated steel frame, glass inserts standard (<i>Optional: metal inserts</i>)
Electrical Parts 115/60/1 (3 Amp)	Fan Motor	ECM high efficiency
	Lighting	LED
	Solenoid Valve	Hermetic direct acting solenoid valve for refrigeration (24V DC)
Pipe Size of Connection Point	Liquid Line	3/8" OD
	Suction Line	5/8" OD
Refrigerant		R404A standard (<i>Optional: R410A</i>)
Evaporator		Fin tube type
Expansion Valve		External equalized automatic thermal expansion valve
Controller		Digital programmable controller with Modbus communication protocol
Casters		(4) 2" Casters
Drain Pipe Dimensions		1.5" NPT Male Connector
Thermometer		Product simulation thermometer
Internal Volume		20.73 ft ³
Weight		368 lb.
Noise		Less than 65 dB at 4 ft.
Agency Approvals		ETL File #4007858 Conforms to ANSI/UL 471, NSF Conforms to ANSI Std 7 Type II

NOTE: The manufacturer reserves the right to make product improvements and change specifications without notice



SAFETY PRECAUTIONS

- Electrical service installation should only be performed by qualified, licensed Electricians.
- Mechanical service should only be performed by qualified, licensed Service Technicians.
- Use adequate equipment when moving the Refrigerated Showcase (RSC).
- Test for proper grounding to reduce the risk of electrical shock and fire.
- High voltage is present in the RSC. Disconnect power before servicing.
- Use only fully trained service technicians for power-on servicing.
- Use only authorized replacement parts.
- Be aware of inherent dangers in rocking or tipping the RSC.
- Lines are pressurized with nitrogen. Use caution when opening lines.
- Use refrigeration lines with adequate wall thickness to handle refrigeration pressures.
- Replacement fuse must have identical ratings as the fuse being replaced.
- If glass cracks or breaks, discard food items, and thoroughly remove all glass fragments.
- Do not place objects on top of the RSC that can fall or spill.
- The RSC is designed for indoor use only, in a controlled environment that typically does not exceed 80°F (27°C). Check system airflow as described in this document to ensure food is maintained at required temperatures.

UNPACKING

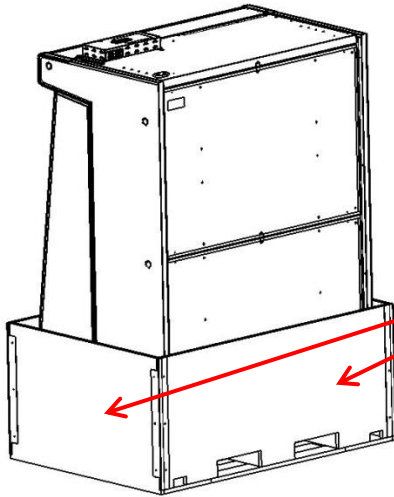

- 1) Remove the crating materials from the unit (shipping straps, corner brackets, wood panels & cardboard corner posts)

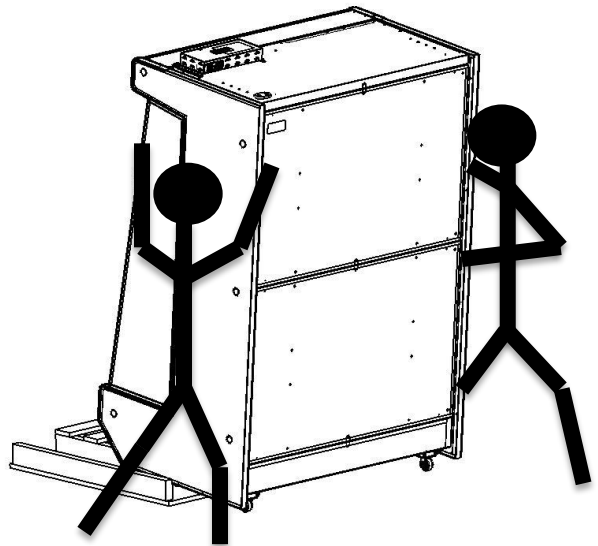
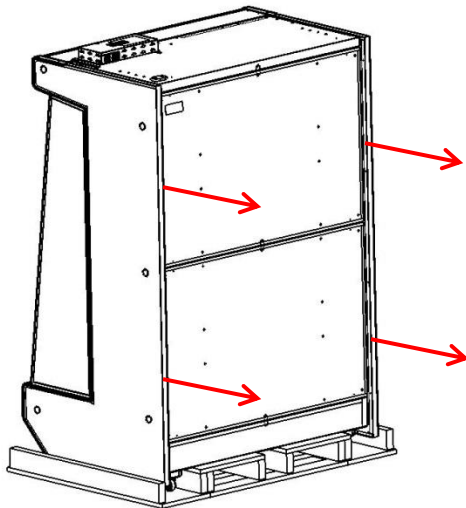

- 2) Slide the unit **REARWARDS** off pallet onto dolly(s) or loading mules. Note: **DO NOT** use the unit casters to move the unit anywhere other than in its final installation location.



INITIAL SET-UP

The Model RSC Remote Refrigerated Showcase, when properly installed and maintained, is designed to provide years of trouble-free operation. This Operation & Installation Manual contains information necessary for proper installation, maintenance and cleaning of the unit.

If connecting 2 or more RSC units together, refer to separate RSC connection instructions provided with these units.

It is the responsibility of the installer to ensure the unit is installed and working properly. The following instructions provide step-by-step set-up, piping, condensate drain connections, wiring, start-up, performance and maintenance guidelines.

For Parts or Technical Service, please call: 1-800-344-7216 or FAX: 1-800-541-5684 or email: customerservice@vendoco.com

Additional reference manuals can be obtained at www.vendoco.com

CABINET SET-UP

- Step 1: Choose a location for your new refrigerated display case. Avoid placing the cabinet near equipment that releases heat. Avoid direct sunlight. To protect all electrical parts, do not place the cabinet where it will be subjected to rain, splashed liquid, or excessive humidity.
- Step 2: Check the airflow around the cabinet, since strong airflow may displace the cooled air in the Showcase. Place the cabinet where the airflow speed is less than 60 ft/min. Also, avoid areas subject to strong winds (see figures 1-7).

AIR CONDITIONING DUCT (CEILING TYPE)

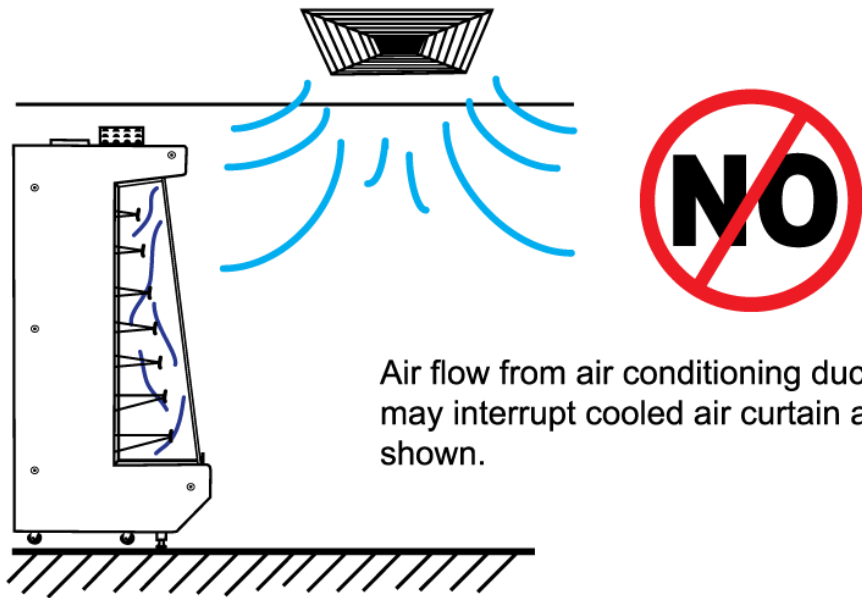

Air flow from air conditioning duct may interrupt cooled air curtain as shown.

FIGURE 1

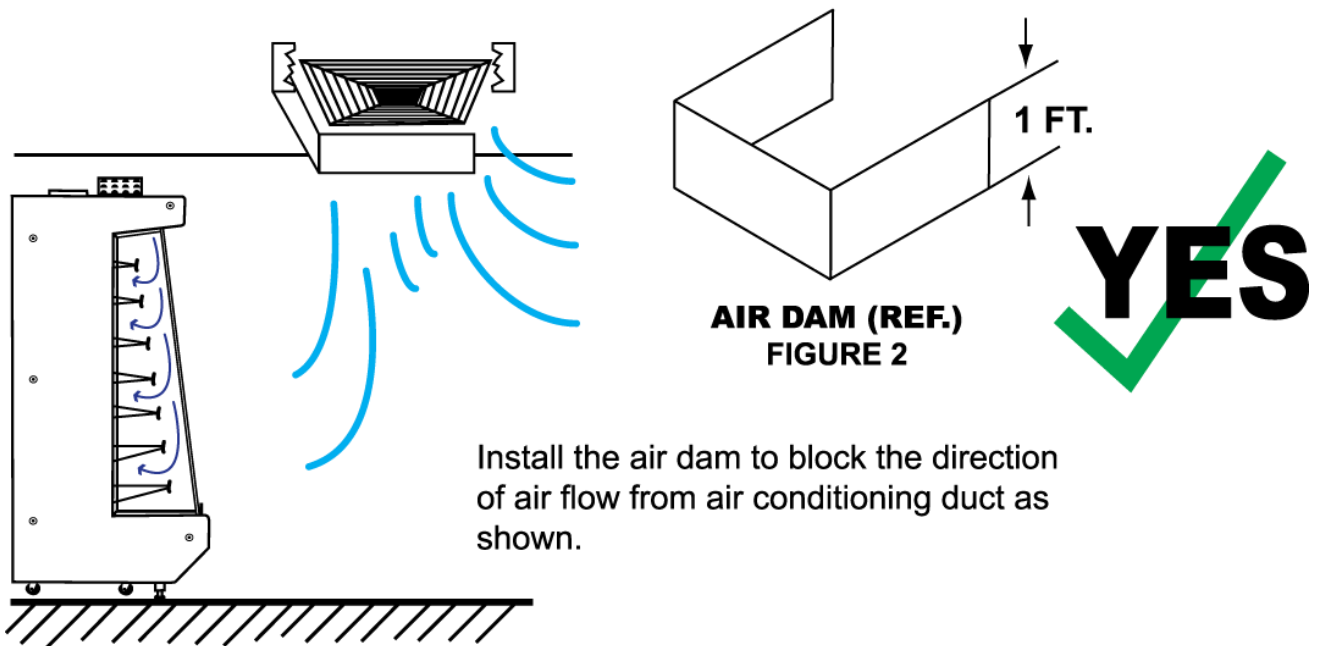

**AIR DAM (REF.)
FIGURE 2**

Install the air dam to block the direction of air flow from air conditioning duct as shown.

FIGURE 3

AIR CONDITIONING DUCT (WALL TYPE)

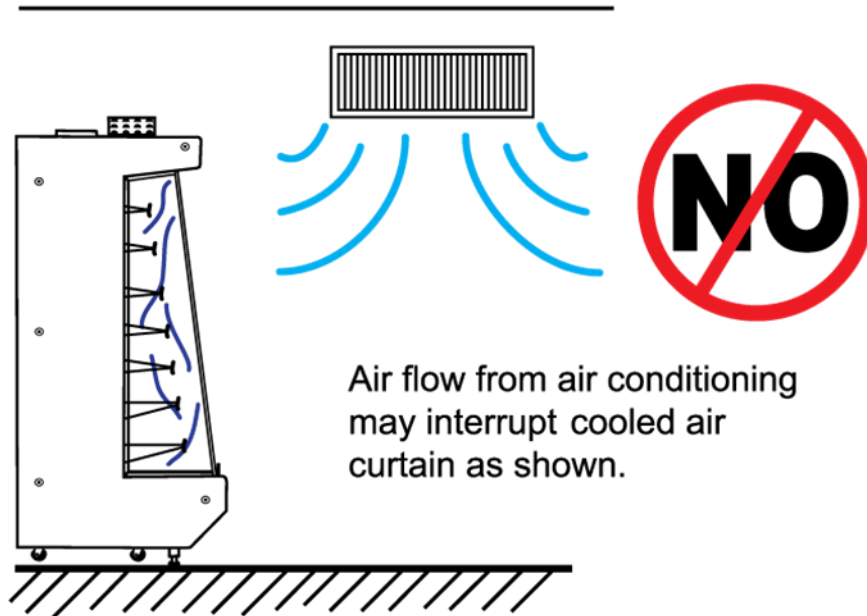

FIGURE 4

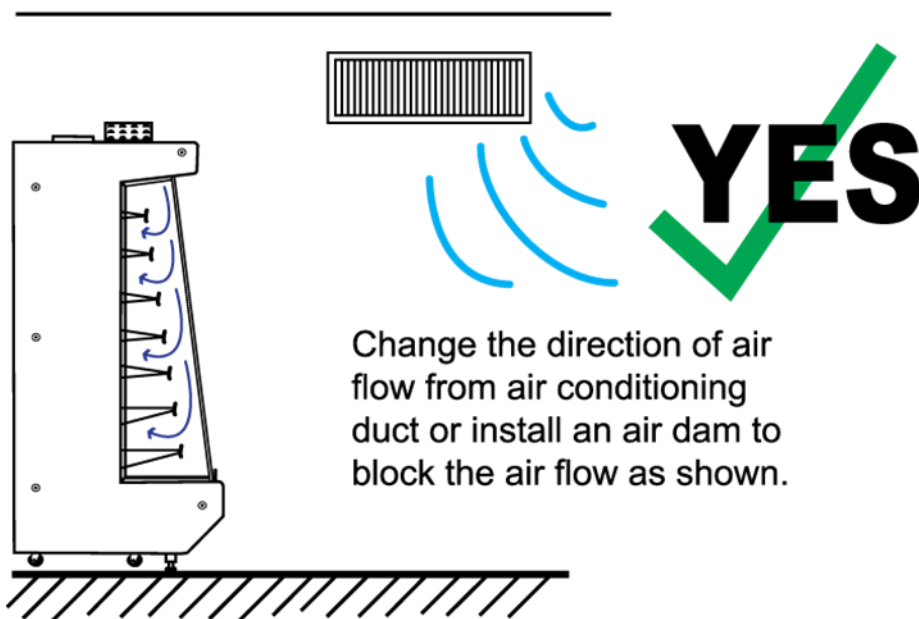

FIGURE 5

TO CHECK AIR CURTAIN

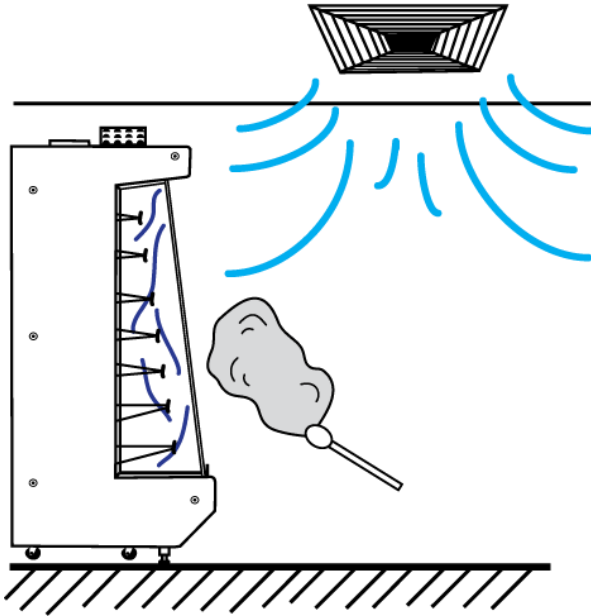

FIGURE 6

Hold smoke stick 1 foot from front opening of showcase as shown.

If smoke travels upward, then the air curtain is present.

If smoke travels into showcase the air curtain is not functioning correctly.

Another indication of a non-functional air curtain is the presence of condensation on the inside back surface of the showcase unit as shown.

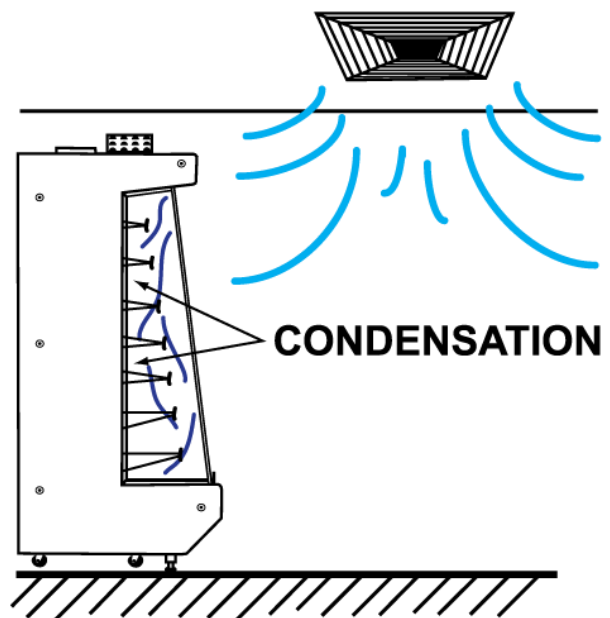
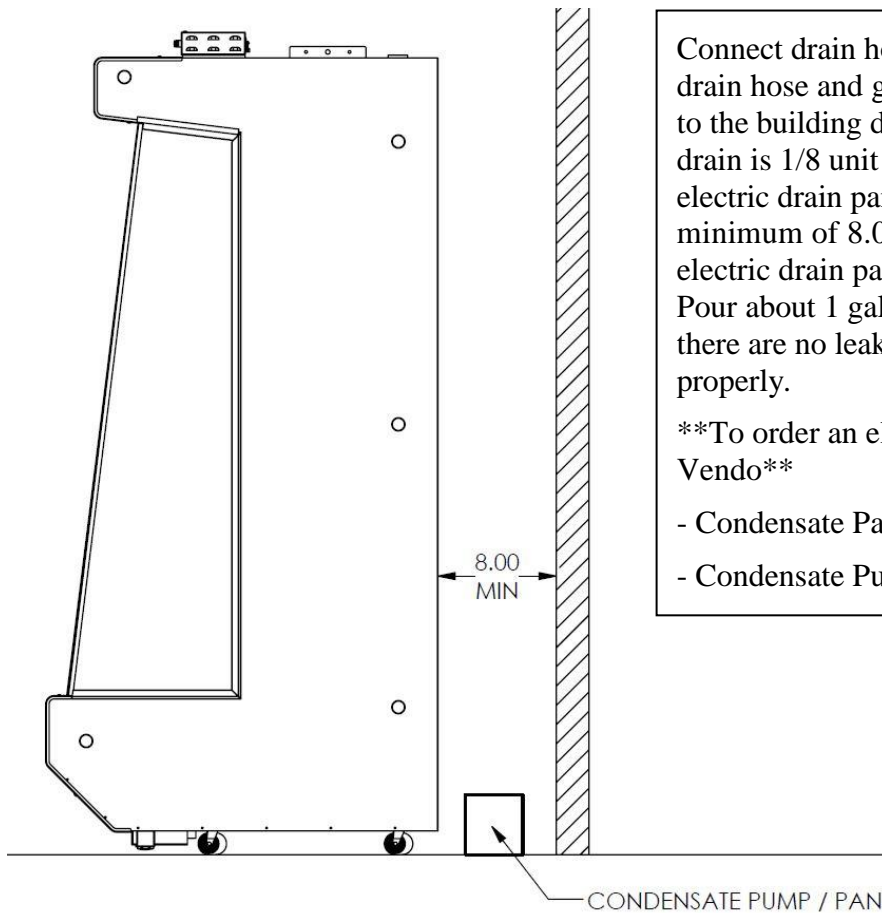

FIGURE 7



Connect drain hose to the RSC unit using the included drain hose and gasket (pictured below). Attach the hose to the building drain system. The required pitch of the drain is 1/8 unit vertical in 12 unit horizontal. If using an electric drain pan or pump, the RSC unit must be a minimum of 8.0 inches away from the wall. Connect electric drain pan or to a separate 115V power supply. Pour about 1 gallon of water into the RSC drain to verify there are no leaks, and the drain system / sump / pan work properly.

****To order an electric sump or drain pan contact Sanden Vendo****

- Condensate Pan, Evapoway (SVA Number 1241338)
- Condensate Pump (SVA Number 1231359)

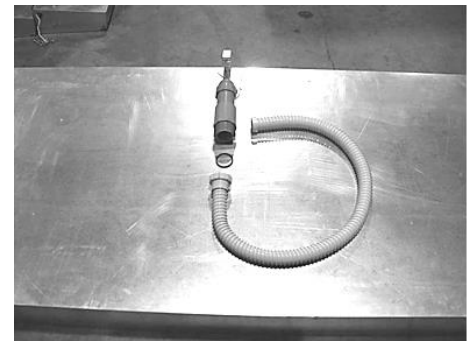

Install the Leveling Legs by sliding the leg into the pre-installed Holding Bracket. Begin installation by hand, and finish with a soft mallet. Insure unit is level by lowering and adjusting Leveling Leg Bolts. Insure the RSC does not roll and push down Thread Cover.

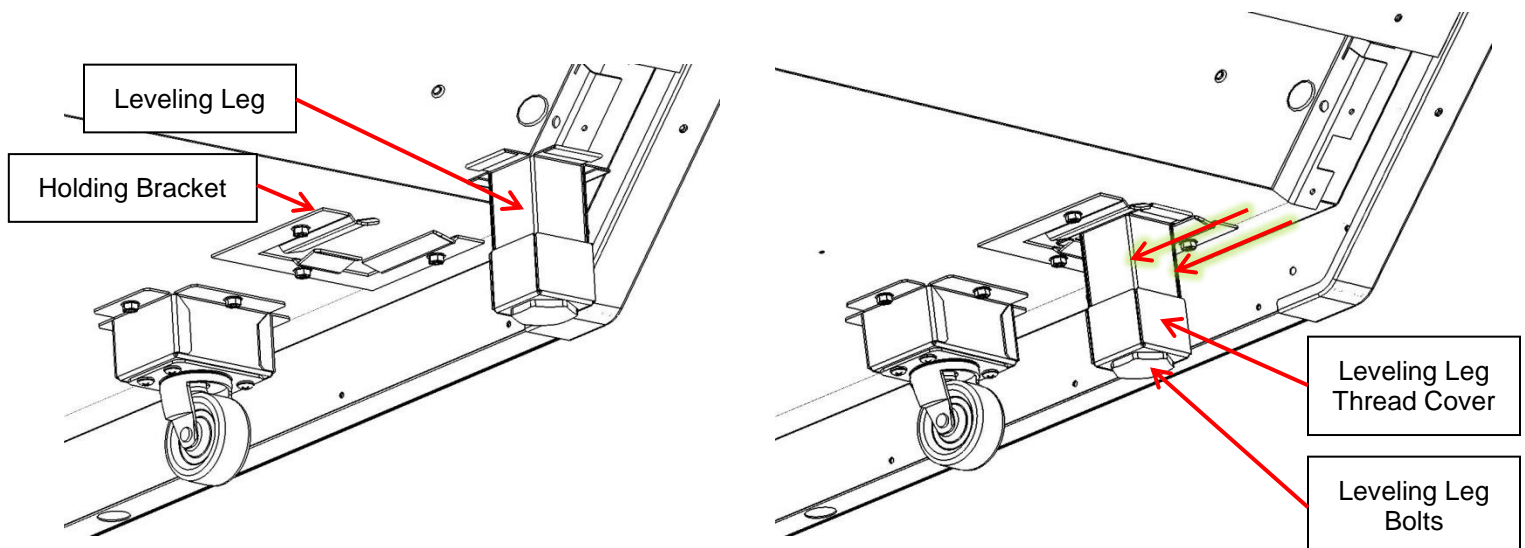

Install condensate fans (one each side for RSC 6 model, or one in the center for the RSC 3 & RSC 4 models) using two V802087 screws provided and connect power cable to harness (not shown). (NOT USED ON UNITS PRODUCED AFTER 9-5-17)

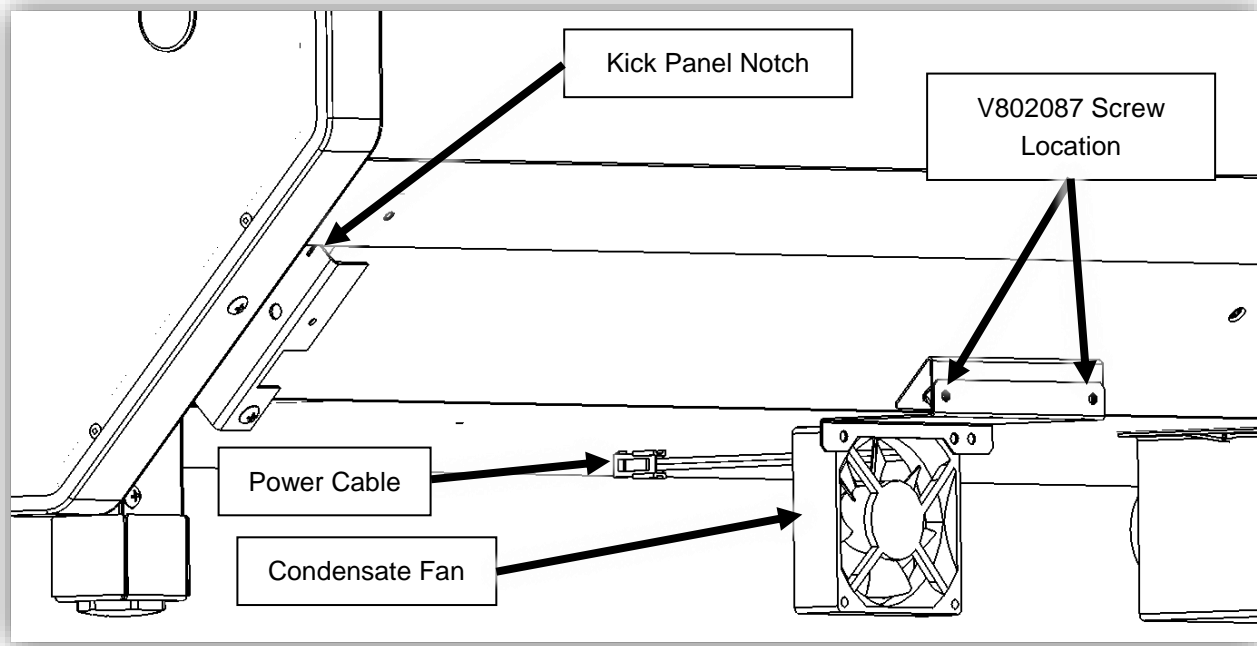

Install lower kick panel and engage upper lip in notches.

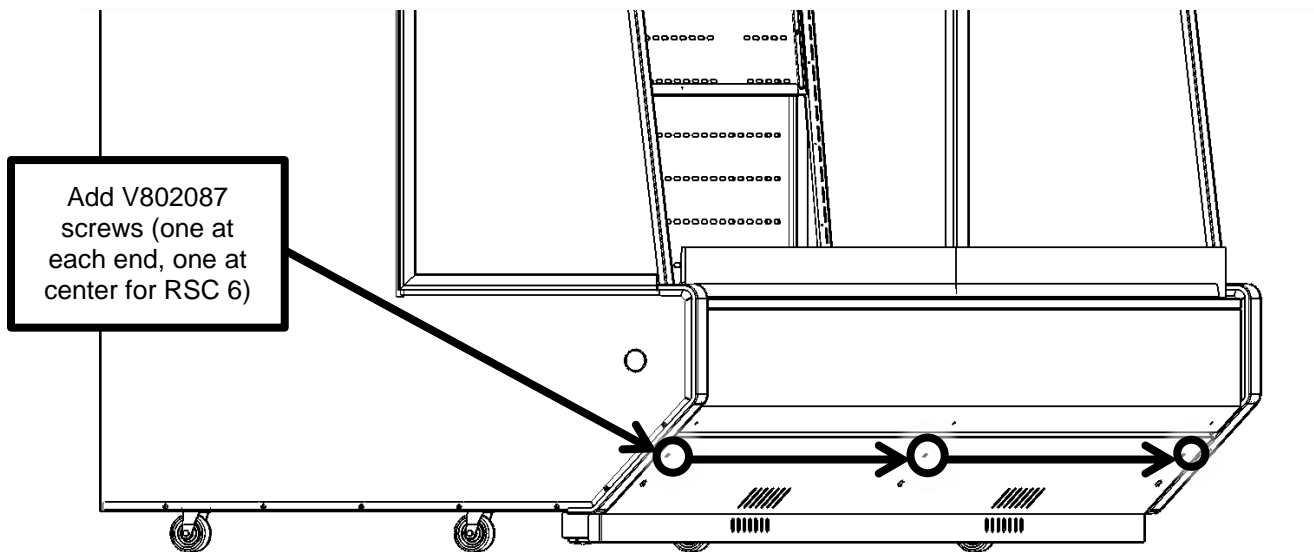

ELECTRICAL INSTALLATION

Have a qualified electrician remove the electrical box cover and connect electrical service (115 VAC, 3 amp 1 phase, copper conductors only) through one of the strain reliefs to the line, neutral and ground connections on the terminal block according to the labels stamped in the metal.

Remove cover from power control box by removing top screw.

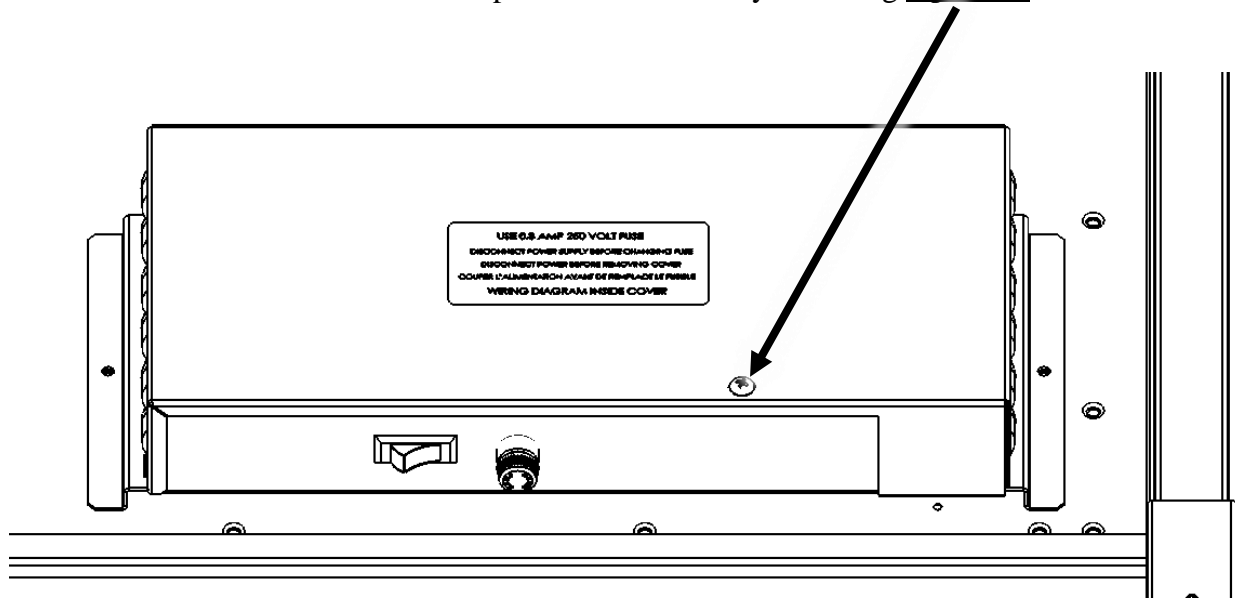

Secure the power cable in the strain relief. Reinstall the electrical box cover.

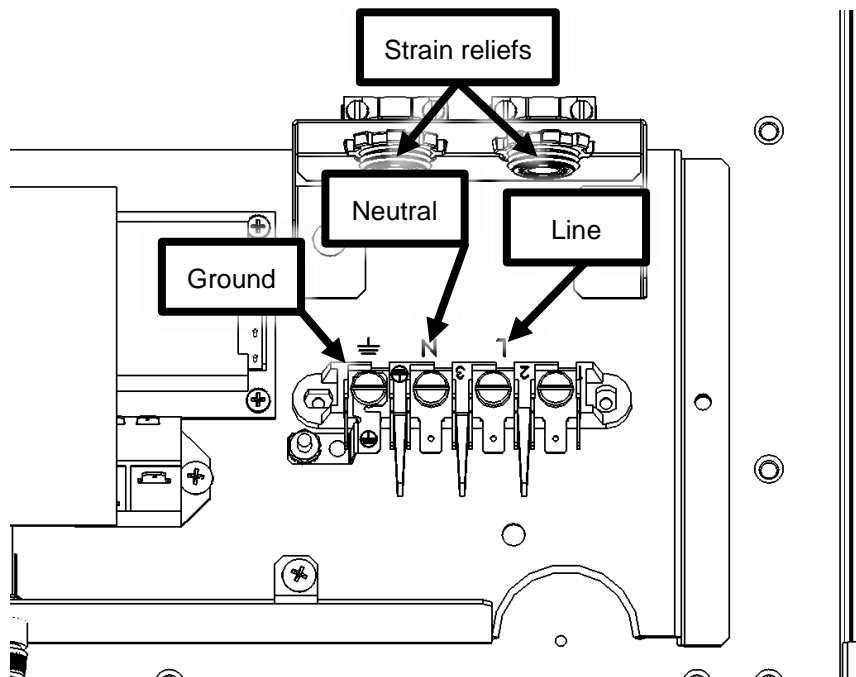

Wiring Diagram RSC Remote

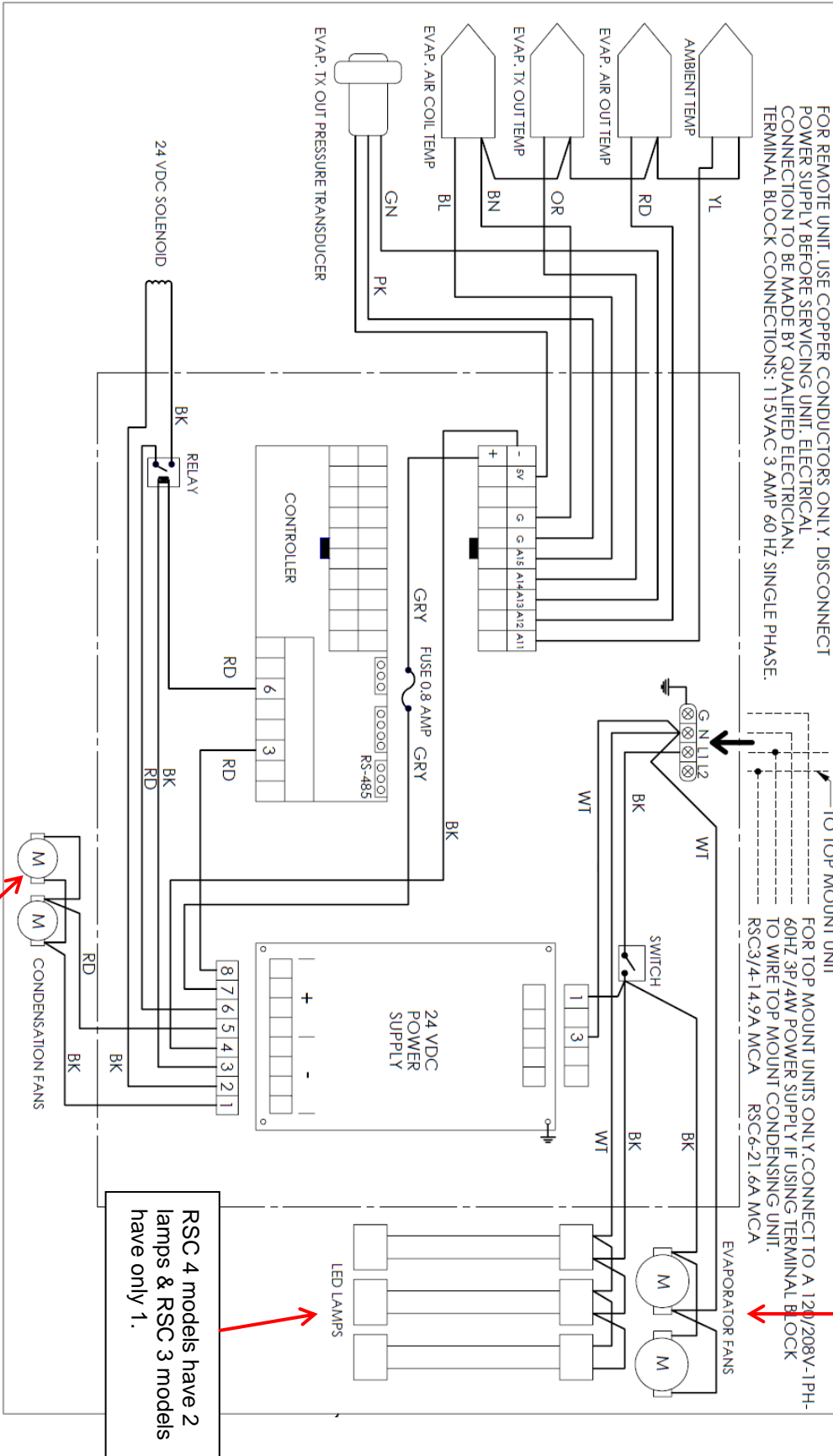

RSC 3 and RSC 4 Models only have one condensation fan.

RSC 4 models have 2 lamps & RSC 3 models have only 1.

RSC 3 and RSC 4 Models only have one evaporator fan.

REFRIGERATION INSTALLATION

After the RSC unit is in its final location and leveled, have a qualified refrigeration technician connect the condensing unit to the RSC's refrigeration connection lines.

- 1) Utilizing proper refrigeration practices connect the refrigerant lineset to the RSC stub outs using long radius fittings. Trim the line set length so as to keep from creating oil traps in the lines.

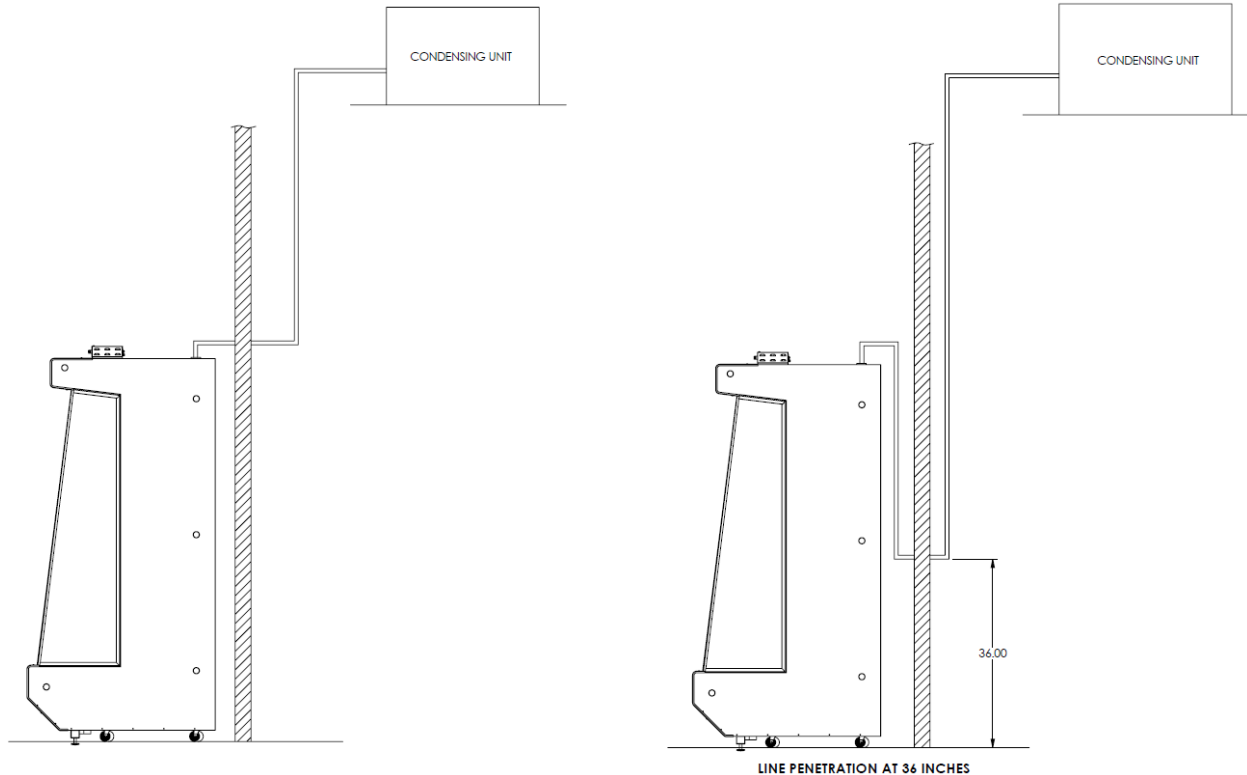

- 2) Connect lineset to the remote mounted condensing unit.
- 3) Turn on power to the RSC to open liquid line solenoid, ALL brazing should be done under a low pressure nitrogen purge.
- 4) After brazing, pressurize system with nitrogen and check brazed joints for leaks.
- 5) After leak checking, release the nitrogen and evacuate the system to 400 microns or below. Verify the system holds this vacuum before weighing in the refrigerant charge.
- 6) Break vacuum with liquid refrigerant through the HIGH side access port at the condensing unit.
- 7) Turn power on to the condensing unit and continue charging through the LOW side port using a metering device such as a "Quik Charge" or Uniweld's "Vapor Vue". Stop charging when sight glass clears and check for required superheat of 10-12 degrees F.
- 8) Weigh in an additional two (2) pounds of refrigerant to insure proper sub cooling.

- Evaporator superheat 10 to 12°F. System operates with a controller set point and solenoid valve (pump down). Condensing unit must have low pressure switch.

- 6 ft model: 11,800 BTU/hr, evaporating temp: 15°F @ 80°F dry bulb, 68°F wet bulb

- 3 & 4 ft models: 6,800 BTU/hr evaporating temp: 15°F @ 80°F dry bulb, 68°F wet bulb



- Turn on the condensing unit and the RSC. Insure the lights and fans operate. The control system is factory preset and does not need adjustment. Allow the RSC to run for 1 hour and check the temperature on the high quality dial thermometer to insure the case is below 41°F.
- Air curtain disturbance must be checked, (see figures 1-9).

VALENCE INSTALLATION INSTRUCTIONS

Parts List

Quantity	Part Number	Description
1	Black: 1240129 (RSC3) or 1240137 (RSC4) Or 1240145 (RSC6) or White: 1240196 (RSC3) or 1240218 (RSC4) Or 1240226 (RSC6)	Valance, Front
1	Black: 1240188 or White: 1240242	Valance, Right
1	Black: 1240153 or White: 1240234	Valance, Left
7	V802087	Screw

Step 1
Remove
screws

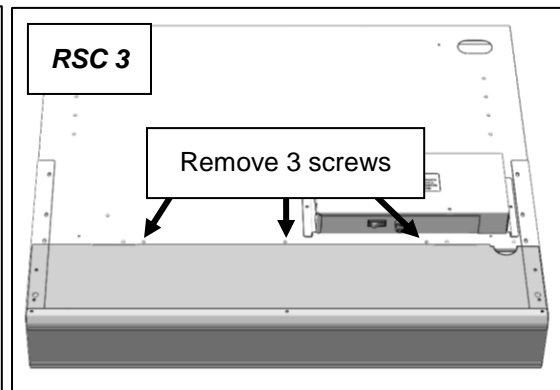
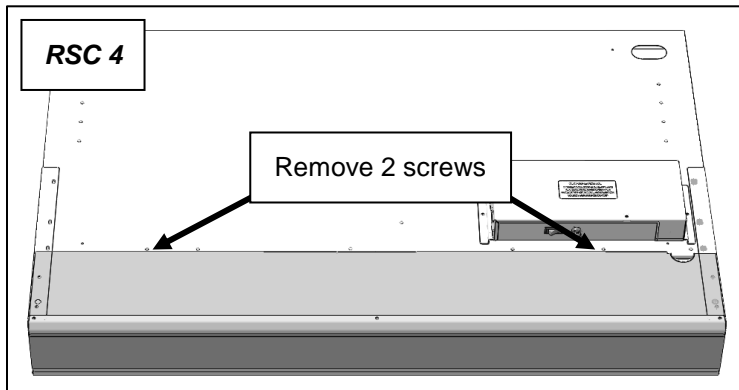
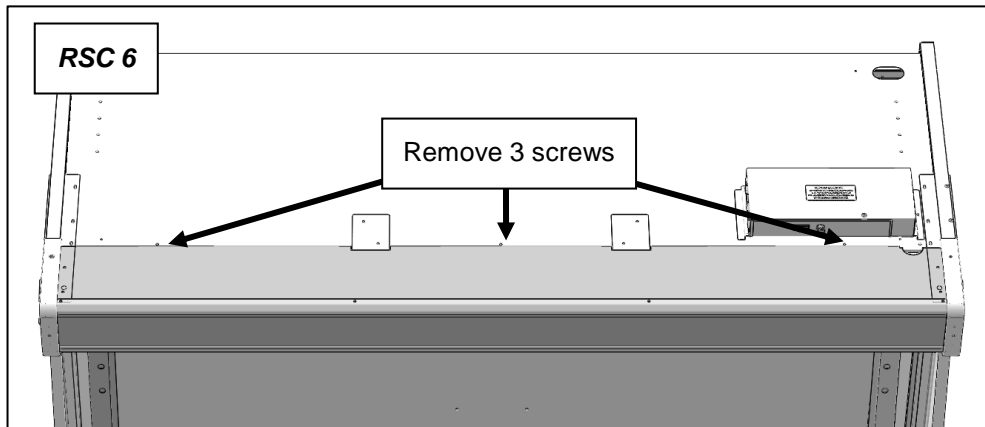

Step 2
Install side valances

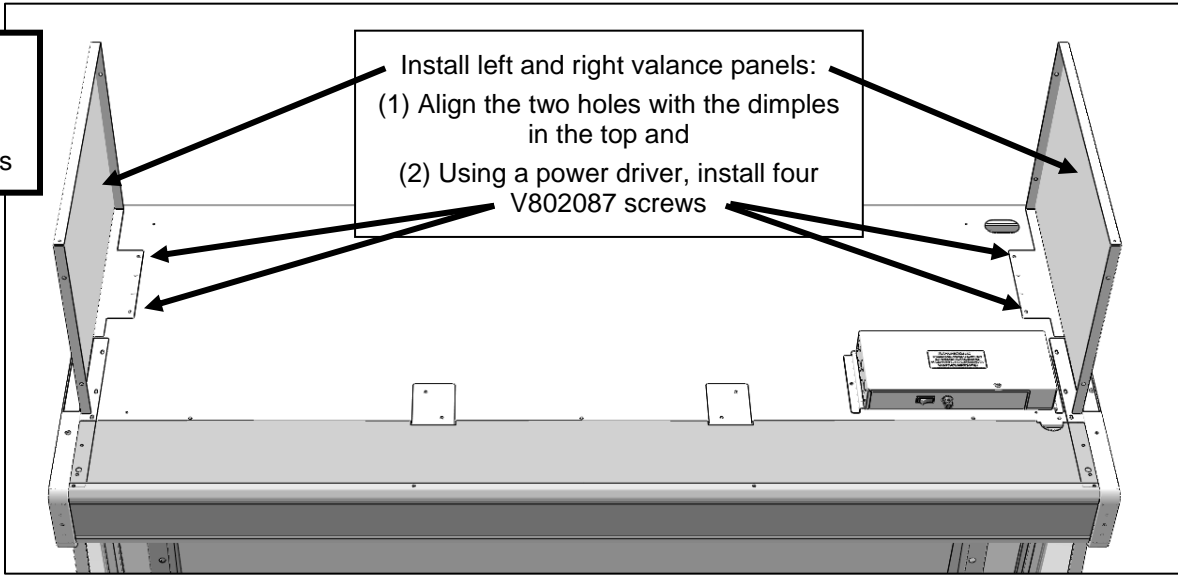

Step 3
Install front valance

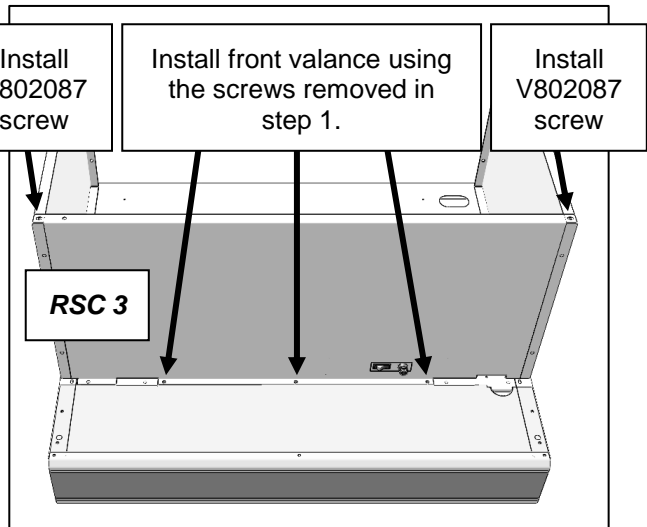
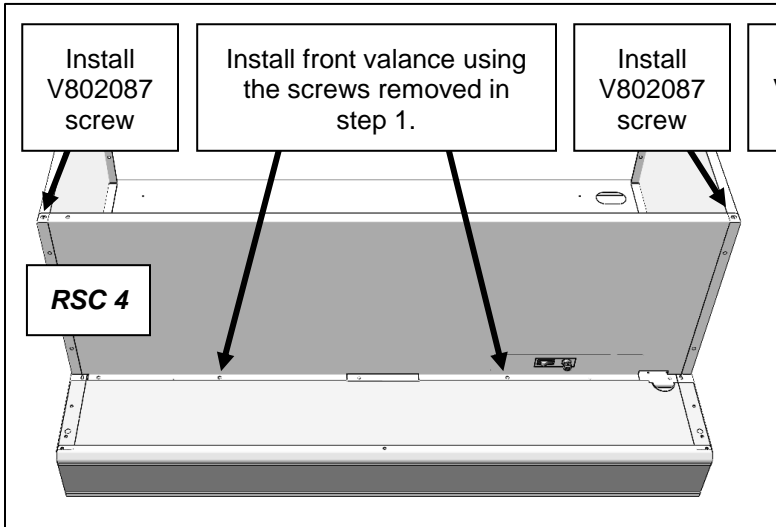
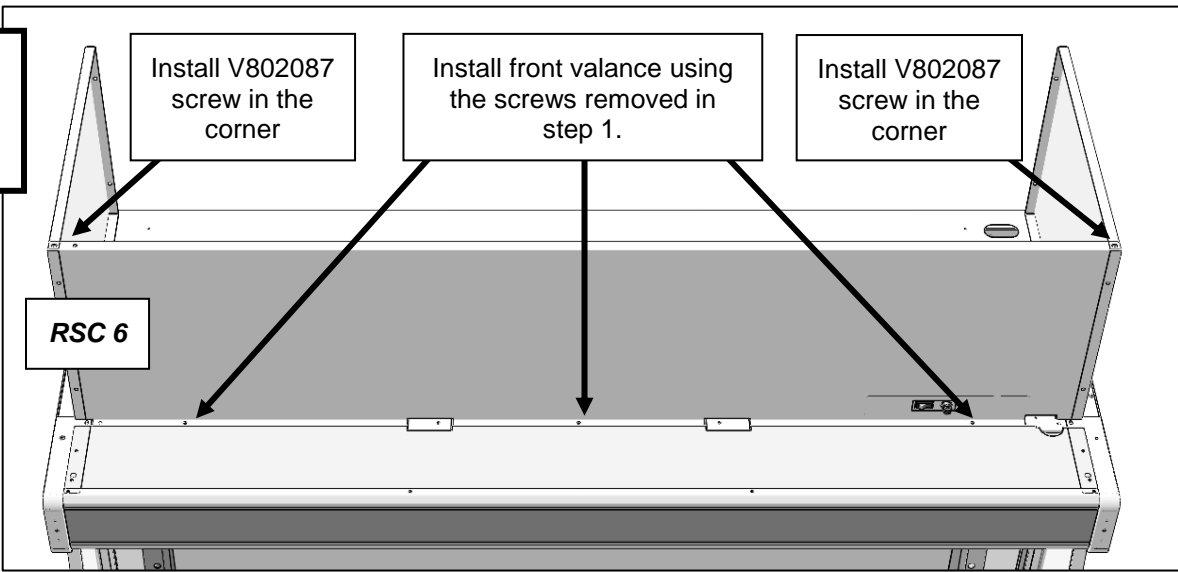

START-UP & OPERATING INFORMATION

START-UP INFORMATION AND PERFORMANCE EVALUATION

- Step 1: Turn on power switch located on the front of the power control box. Start up the condensing unit per manufacturers guidelines. Check to ensure evaporator fans are operational, and the LED lighting is on.
- Step 2: While the condensing unit and evaporator fans are running, verify that there is a flow of cold air from the honeycomb, located at the top of the cabinet.
- Step 3: Observing the controller display, monitor the cabinet temperature, and verify that unit cools to 40°F within 20-30 minutes.
- Step 5: Verify that all access-cover panels have been replaced, and the cabinet is ready to be loaded by store personnel.

OPERATING GUIDELINES

1. For best results, pre-cool all products before stocking the display case.
2. Stock products only after the cabinet has cooled.
3. When loading the cabinet, do not place merchandise over the grill located in the front of the lower deck plate as this will disrupt the air curtain. (Reference Below)
4. Allow at least 1" between the upper surface of the displayed product and the shelf directly above it, and 1" from the rear wall. (Reference Below)

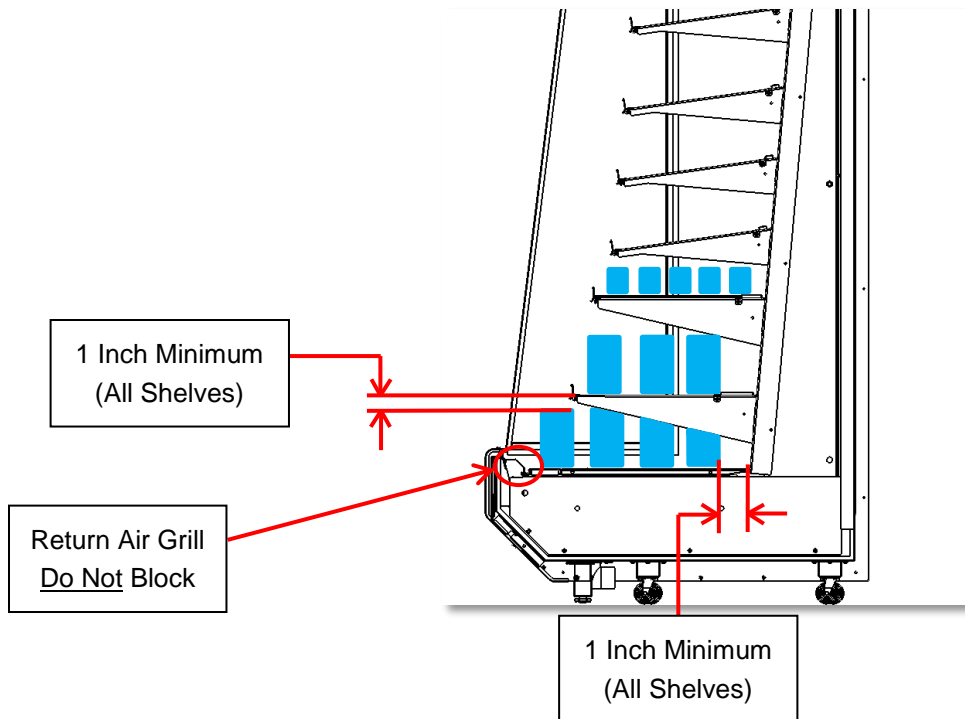

5. For proper temperature sensing, do not put product against the temperature sensor on the back wall.
6. Do not remove the glass side panels during operation.



CONTROLLER OPERATION AND ERROR CODES

RSC controller button functions:

- F1** - Scroll Up
- F2** - Return / Esc
- F3** - Scroll Down
- F4** - Enter / Set



To Enter Reading Mode: Press F4 – The Display will read “Ai” – use buttons to navigate

Level 1	Err #	Description
tEnP		Display Ambient Temperature
COIL		Display Coil Temperature
EU0P		Display Evaporator Outlet Pressure Sensor
EU0t		Display Evaporator Outlet Temp
EUA0		Display Air Out Temperature
SuHt		SuperHeat = EU0P - COIL
AL		Alarm - if present, will override the message on the display
	Err 1	Ambient Temperature is disconnected or faulty
	Err 5	Coil Temperature is disconnected or faulty
	Err 3	Pressure Transducer is faulty or not connected
	Err 4	Evaporator outlet temperature is disconnected or faulty
	Err 2	Air Out Temperature is disconnected or faulty

To Check the Firmware Version: Press F2 and hold for 5 seconds – The version will show.

GENERAL MAINTENANCE

CLEANING THE HONEYCOMB

In order to maintain peak operating performance, remove the honeycomb (as shown below) and rinse it with clean water to remove dust. Under normal conditions, inspect and clean every 90 days.



Step 1: Remove honeycomb filter once every 90 days from upper section behind lights.

Step 2: To remove the filter pull down the tab located in the back of the filter.

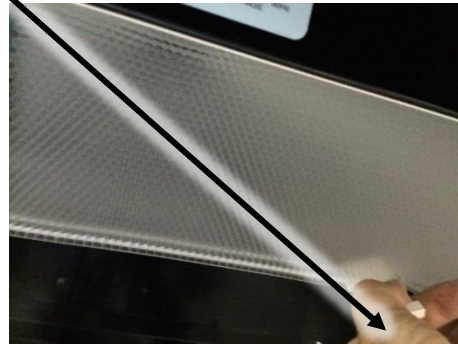

Step 3: Wash the honeycomb with water only to remove dust and dirt. Shake the water from the filter and wipe off with a paper towel. Recommended sinks for cleaning- Mop sink as a primary recommendation, wash bay in 3-comp sink secondary option- must clean and sanitize sink before and after use.

Note: The honeycomb does not need to be completely dry before it is placed



Step 5: Replace the honeycombs by pushing in the front tabs first and pushing up on the back side.



Note: Depending on the model of the RSC there may be multiple honeycombs.

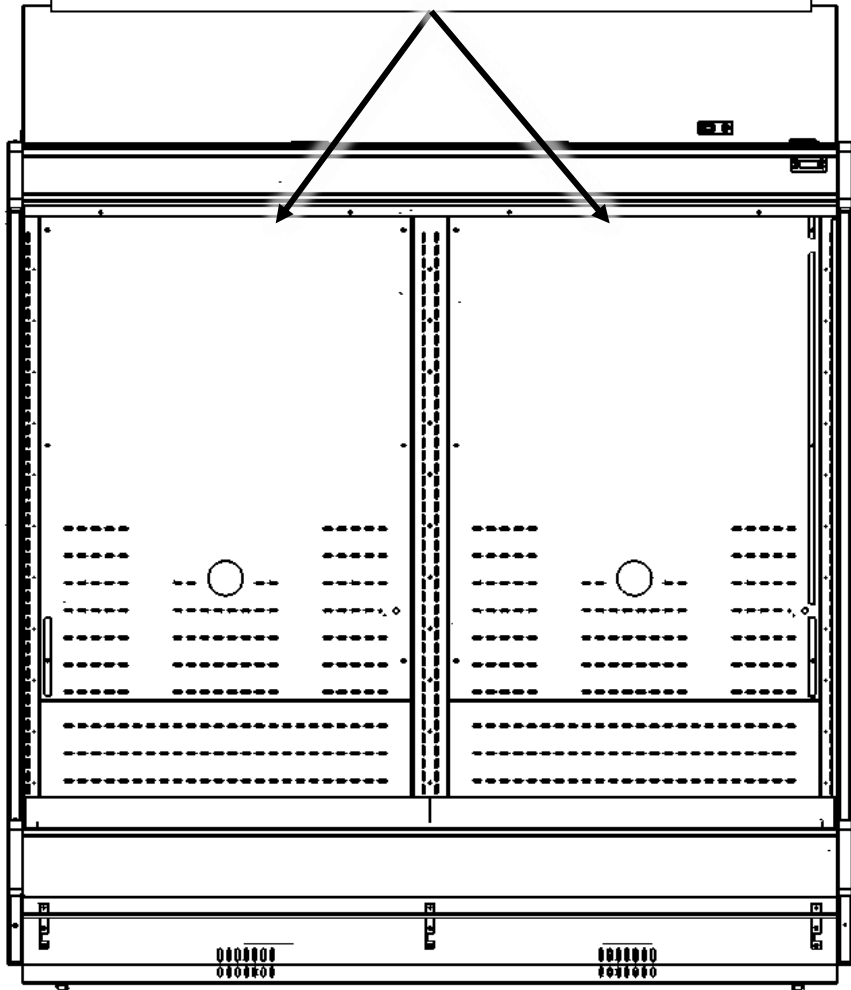

CLEANING THE FILTER

In order to maintain peak operating performance, remove the filter (as shown below) and rinse it with clean water to remove dust. Under normal conditions, inspect and clean every 90 days.



Step 1: Remove filter once every 90 days from upper section behind lights.

Step 2: Wash the filter with water only to remove dust and dirt. Shake the water from the filter and wipe off with a paper towel. Recommended sinks for cleaning- Mop sink as a primary recommendation, wash bay in 3-comp sink secondary option- must clean and sanitize sink before and after use.

Note: The filter does not need to be completely dry before it is placed back in the RSC Showcase.



Step 4: Replace the filters by dropping filter into the brackets by the front grill.

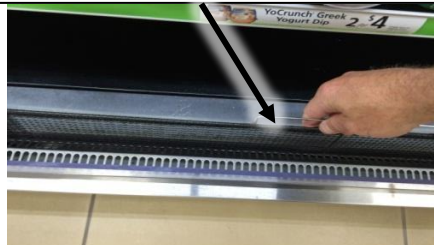

Note: Depending on the model of the RSC there may be multiple filters.

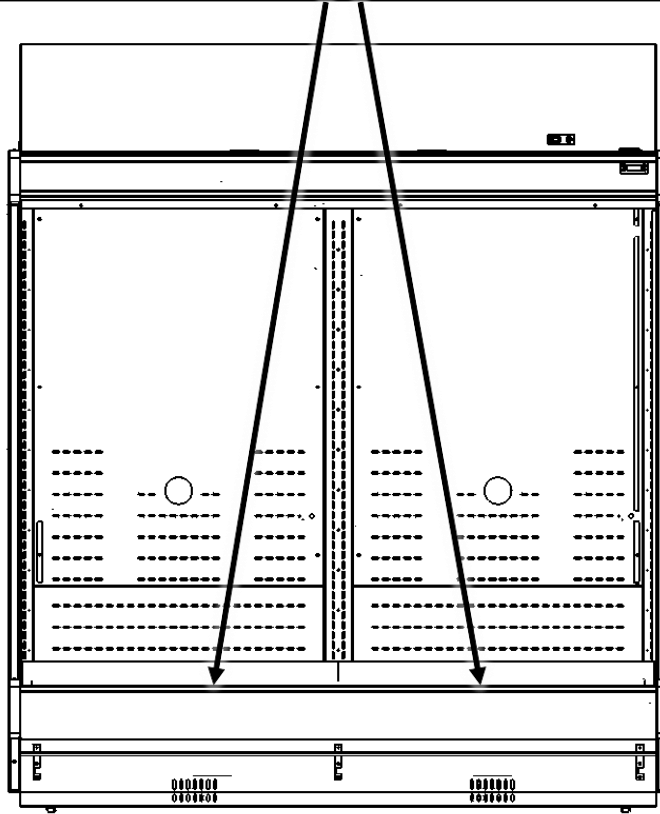

CLEANING THE BOTTOM OF THE INNER BOX & DRAIN

Lift the fan duct, as shown below, and clean the bottom of the inner box with a mild detergent and a soft, damp cloth. Check the drain hole for proper water flow and remove any blockage. Rinse with clean water.

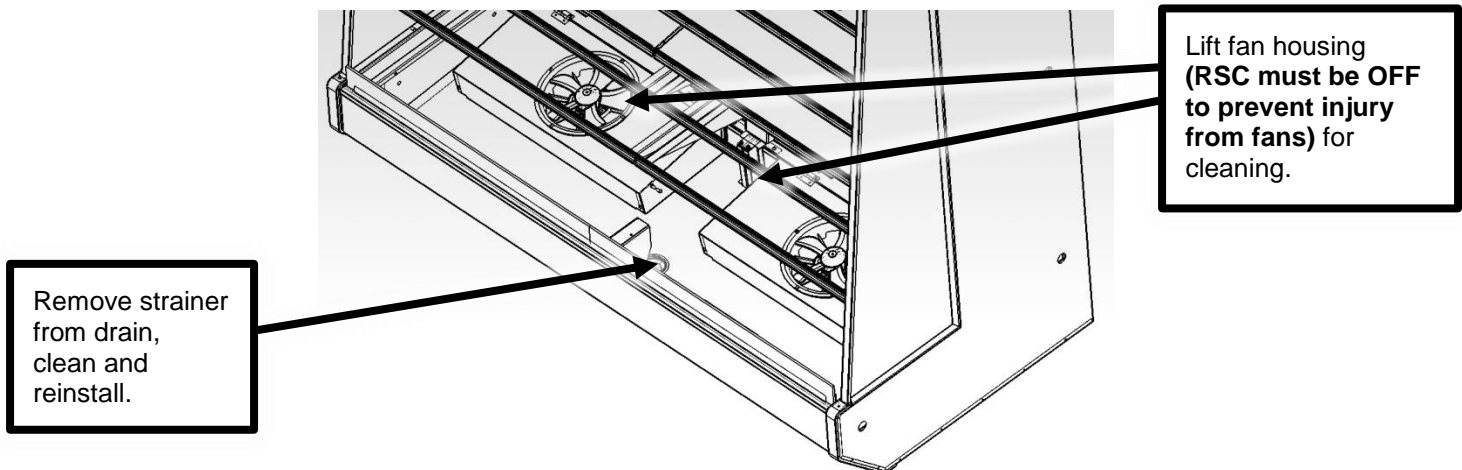



For units with the condensing unit mounted on top, inspect the condenser fins at least once every three months. Brush out or vacuum any dirt or lint that has accumulated in the fins.

CLEANING THE CABINET

To clean the cabinet and shelves, use a mild detergent and a soft, damp cloth. Rinse with clean water. Do not use paint thinner, laundry detergent, harsh chemicals, or abrasive pads or cleaners.

STORING THE CABINET

Step 1: Disconnect the unit from its power source.

Step 2: Wipe the interior of the RSC with a damp cloth.

Step 3: Cap off refrigeration connection lines.

Step 4: Unit must be stored indoors in a clean, dry place. Do not choose a location where the unit will be exposed to direct sunlight, high temperature, or high humidity.

TROUBLESHOOTING

Before calling your Service Technician, please make these simple checks:

If the unit is not operating:

1. Is there a main-power failure?
2. Is there a blown fuse?
3. Has the refrigeration unit cycled off, because it is at the designated operating temperature?

If the LED light is off:

1. Is the LED tube properly connected to the power source?

If the cabinet temperature is too warm:

1. Is the controller set-point set correctly?
2. Is the cabinet located in direct sunlight?
3. Is the cabinet located in a strong air-flow path?
4. Is the distance between the upper surface of the displayed merchandise and the shelf directly above it at least 1”?
5. Is the air temperature around the cabinet above 80°F?

REFER TO THE ENVIRONMENTAL CONSIDERATIONS, ON PAGES 8 AND 9, THAT WILL AFFECT COOLING PERFORMANCE.

Item	Description	Controller Alarm Display or Symptom	Part #	Action
1	Ambient Temp. Sensor	Err 1 / Err 6	1256245	Sensor disconnected or out of range. Check sensor wire continuity to controller, or replace sensor
2	Evaporator Air Coil Temp. Sensor	Err 5 / Err 7	1256245	
3	Evaporator Outlet Pressure Sensor	Err 3	1220143	
4	Evaporator TX Outlet Temp. Sensor	Err 4	1256245	
5	Evaporator Air Out Temp. Sensor	Err 2	1256245	
6	Evaporator Fan Blade	Excessive noise from fan, blade wobble	1220804	Replace fan blade
7	Evaporator Fan Motor	Fan not turning, RSC not cooling	1262025	Check 115 VAC is getting to motor; replace motor
8	Controller	RSC not cooling	1243039-1.07	Turn off power to RSC and turn back on; confirm remote refrigeration unit is working properly; replace controller
9	Condensation Fans	Moisture accumulating on bottom of RSC	1218646	If fan isn't turning, check fan is getting 24 VDC; replace fan
10	Solenoid Valve	RSC not cooling	1220789	Confirm 24 VDC is getting to solenoid; replace solenoid

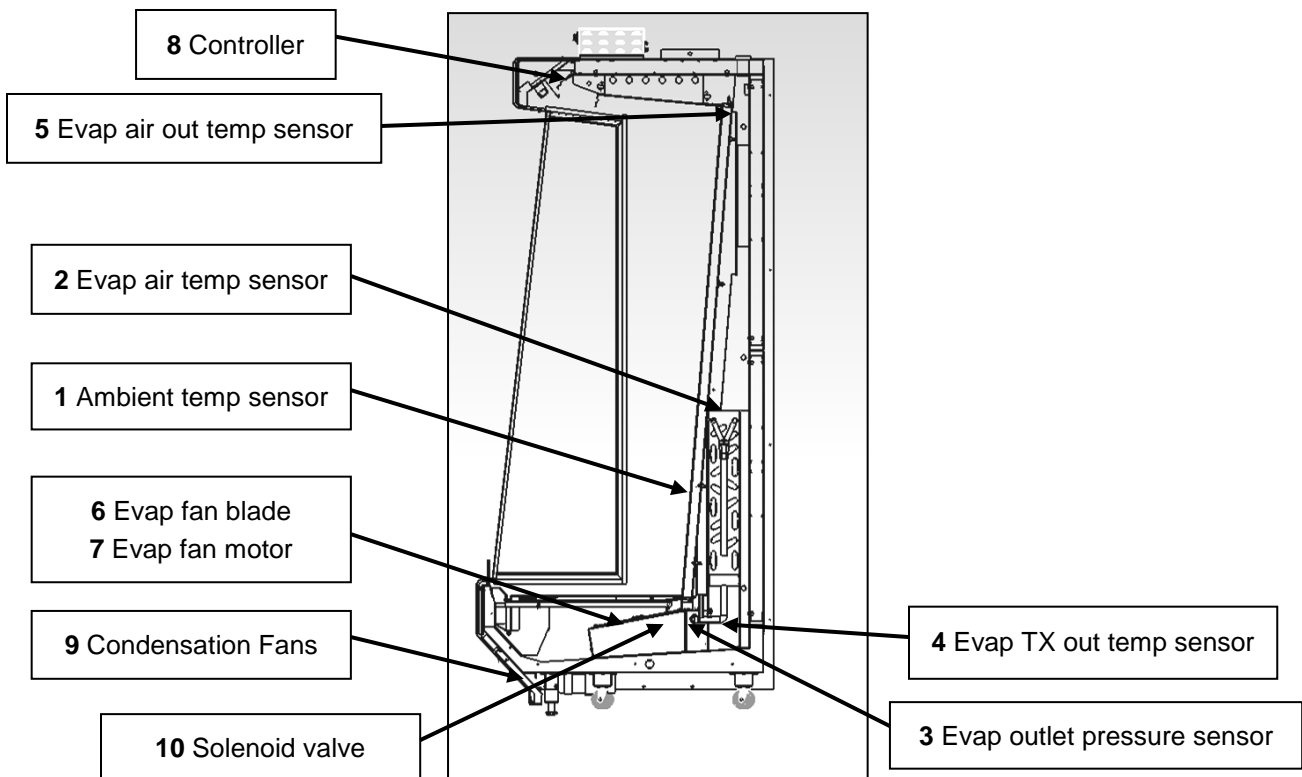

SERVICE PARTS

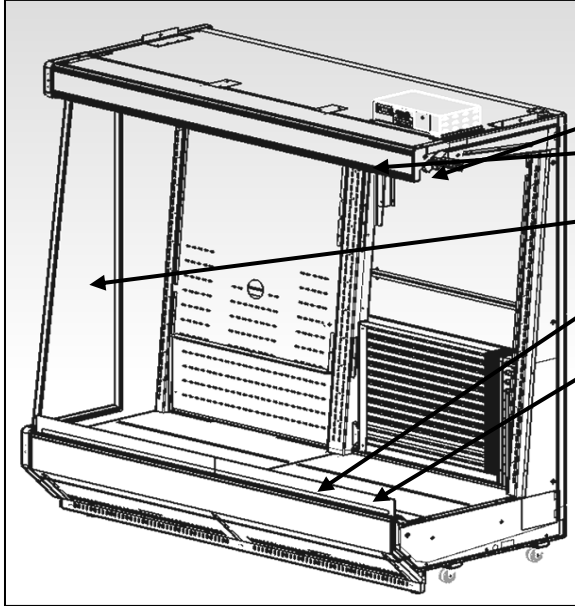

- Other Replacement Items:**
- 1217228-2 LED, 2ft, 115VAC
 - 1239465-1 Honeycomb (RSC 6 & RSC 3)
 - 1239465 Honeycomb (RSC 4)
 - 1212704 Side Glass
 - 1213962 Lint Filter
 - 1215798 Air Dam (RSC 6 & RSC 3)
 - 1215798-1 Air Dam (RSC 4)
 - 1214585 Shelf Glass (7 pcs)
(not shown)
 - 1214594 Drain Strainer
(not shown)
 - 1216042 Controller
(not shown)

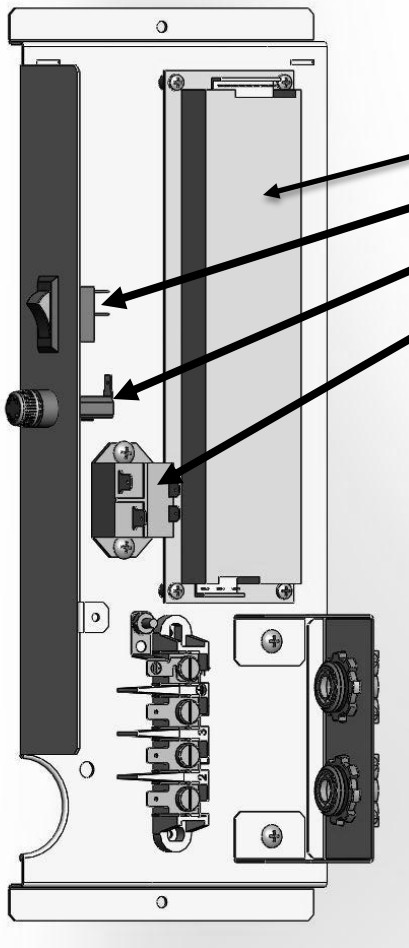

- Power box components:**
- 1221374 Power Supply, 24VDC
 - 1187843 Rocker Switch
 - 1128474 Fuse Holder & 1053864 Fuse, 0.8A / 250V
 - 1124284 Relay
- Cables (not shown)**
- 1252542 - Harness Low Voltage RSC
 - 1220368 - Harness High Voltage RSC
 - 1220377 - Harness Ground RSC