



## **Stormwater Site Plan**

*PREPARED FOR:*

Larson Automotive Group  
1409 Alexander Avenue East  
Fife, WA 98424-1109

*PROJECT:*

Larson River Road Storage  
8424 River Road  
Puyallup, WA 98371  
2160102.10

*PREPARED BY:*

Dan Osier, PE  
Project Engineer

Michael Hager, PE  
Project Engineer

*REVIEWED BY:*

Todd C. Sawin, PE, DBIA, LEED AP  
Principal

*DATE:*

May 2016  
Revised June 2021  
Revised June 2022

## **Stormwater Site Plan**

*PREPARED FOR:*

Larson Automotive Group  
1409 Alexander Avenue East  
Fife, WA 98424-1109

*PROJECT:*

Larson River Road Storage  
8424 River Road  
Puyallup, WA 98371  
2160102.10

*PREPARED BY:*

Dan Osier, PE  
Project Engineer

Michael Hager, PE  
Project Engineer

*REVIEWED BY:*

Todd C. Sawin, PE, DBIA, LEED AP  
Principal

*DATE:*

May 2016  
Revised June 2021  
Revised June 2022



**09/26/2022**

I hereby state that this [Stormwater Site Plan](#) for the [Larson River Road Storage](#) project has been prepared by me or under my supervision, and meets the standard of care and expertise that is usual and customary in this community for professional engineers. I understand that [the City of Puyallup](#) does not and will not assume liability for the sufficiency, suitability, or performance of drainage facilities prepared by me.

# Table of Contents

---

Section	Page
<b>1.0 Project Overview</b> .....	<b>1</b>
1.1 Purpose and Scope .....	1
1.2 Existing Conditions Summary .....	1
1.2.1 Existing Site Features .....	1
1.2.2 Soils.....	1
1.3 Proposed Conditions Summary .....	2
<b>2.0 Offsite Analysis Report</b> .....	<b>2</b>
2.1 Upstream Analysis.....	2
2.2 Downstream Analysis .....	2
<b>3.0 Permanent Stormwater Control Plan</b> .....	<b>3</b>
<b>4.0 Summary of Minimum Requirements</b> .....	<b>3</b>
4.1 MR 1 – Preparation of Stormwater Site Plans .....	3
4.2 MR 2 - Construction Stormwater Pollution Prevention .....	3
4.3 MR 3 – Source Control of Pollution .....	3
4.4 MR 4 – Preservation of Natural Drainage Systems and Outfalls .....	4
4.5 MR 5 – Onsite Stormwater Control .....	4
4.6 MR 6 – Runoff Treatment .....	4
4.7 MR 7 – Flow Control.....	4
4.8 MR 8 – Wetland Protection .....	5
4.9 MR 9 – Operation and Maintenance.....	5
<b>5.0 Construction Stormwater Pollution Prevention Plan</b> .....	<b>5</b>
<b>6.0 Special Reports and Studies</b> .....	<b>5</b>
<b>7.0 Other Permits</b> .....	<b>5</b>
<b>8.0 Operations and Maintenance Manual</b> .....	<b>5</b>
<b>9.0 Conclusion</b> .....	<b>5</b>

# Appendices

---

## Appendix A

### Exhibits

- A-1 ..... Vicinity Map
- A-2 ..... Existing Conditions Map
- A-3 ..... NRCS Soil Survey
- A-4 ..... Developed Conditions Map
- A-5 ..... Flow Chart for Determining Requirements for Redevelopment
- A-6 ..... FEMA Flood Map

## Appendix B

- Geotechnical Engineering Report – South Sound Geotechnical Consulting

## Appendix C

### Maintenance Report

- Attachment A: Maintenance Checklist
- Attachment B: Source Control BMPs

## Appendix D

### Drainage Calculations

- Water Quality
- Conveyance

## Appendix E

- Construction Stormwater Pollution Prevention Plan (CSWPPP)



## 1.0 Project Overview

### 1.1 Purpose and Scope

This Stormwater Site Plan accompanies the site development plans for the Larson River Road Storage project, located on Tax Parcels 0420204047, 0420204059, 0420204267, 0420204282, 0420204069, 0420204063, 0420208027, 0420208030, 0420208039, 0420208040, 0420213006, and 0420213038. The site is bordered by River Road to the north, a commercial business to the northwest, multi-family housing on the northern half of the western border, land on the southern half of the western border, single-family housing south of the project site, and to the east, 15<sup>th</sup> Street NW with commercial businesses. The twelve project parcels combine to be approximately 7.47 acres, and almost the entire area is to be disturbed. Refer to Appendix A, Figure A-1 for a Vicinity Map.

This Stormwater Site Plan is for storm drainage approval. This report describes the design and analysis of the basic treatment and storm conveyance facilities proposed as part of the site improvements. This report will demonstrate that the stormwater design for this project will meet the requirements of the 2012 Department of Ecology (DOE) *Stormwater Management Manual for Western Washington (SMMWW)*, as adopted by the City of Puyallup.

### 1.2 Existing Conditions Summary

#### 1.2.1 Existing Site Features

The existing area is approximately 7.47 acres and is currently developed and undeveloped land cover. Two parcels are in use as a parking lot, these total 1.93 acres. One parcel is undeveloped, grass cover (0.93 acres). Four lots are residential house lots (0.80 acres) with approximately 45% impervious coverage (these lots are to be developed with storm conveyance and fire hydrant infrastructure, they will not be paved due to zoning). And the other 5 lots are the commercial businesses fronting River Road and 15<sup>th</sup> (3.81 acres) with approximately 95% impervious coverage.

There is a slight depression on the undeveloped land in the middle, southern part of the project. The lots used as parking are to the west of this depression and sheet flow towards the depression. There is a conveyance system at the southern property line along these parcels that also collects runoff in several catch basins. The undeveloped and parking lot parcels have existing stormwater conveyance system, but it is in poor condition and the ultimate discharge location of this area is not known, it appears that stormwater likely ponds until it infiltrates onsite. A topographic survey of the project site area was prepared by AHBL that shows existing site conditions and elevations. See Appendix A, Exhibit A-2 for the Existing Conditions Map.

#### 1.2.2 Soils

The Natural Resources Conservation Service (NRCS) classifies the onsite soils as entirely Puyallup fine sandy loam – 31A. Appendix A, Exhibit A-4 provides the NRCS soil map. Puyallup fine sandy loam soils are classified as hydrologic soil Series C, which typically have low erosion and moderate infiltration potential. It should also be noted that the site was previously used for fueling and fuel tanks were recently removed from the site. While these tanks have been removed and further contamination is not anticipated the recommendation as part of the cleanup permit was to cap the site and avoid infiltrating stormwater to ensure any undetected pollutants are not dispersed into the grou

In addition to the NRCS information, South Sound Geotechnical Consulting prepared a geotechnical report for the site. On March 30, 2016, four test pits and two infiltration test holes

were completed. Based on the results of the infiltration testing, long-term infiltration rates were estimated to be 0.08 to 0.11 inch per hour. Due to the presence of these unfavorable soil conditions and high groundwater (encountered between 4.5 and 5.5 feet below existing grade), infiltration is not a suitable discharge option.

See Appendix B for the Geotechnical Engineering Report.

### **1.3 Proposed Conditions Summary**

The proposed improvements include demolition of existing residential houses and driveways. The commercial buildings will all be kept. Storm Conveyance, grading, paving and striping construction will build a large parking for vehicle storage area. This paved area shall be collected in a new collection system. The system will drain to the southeast of the site into a water quality storm cartridge structure prior to discharging east to the existing storm trunk line located below 15<sup>th</sup> Street NW. Since this existing trunk line discharges directly to the Puyallup River, no flow control is required per Appendix I-E of Volume I of the *SMMWW*.

There are four residential lots within the project area. Construction in these lots will include storm conveyance and fire hydrant infrastructure, but will not be included in the paved parking lot due to zoning usage.

See Appendix A, Exhibit A-4, for the Developed Conditions Map.

## **2.0 Offsite Analysis Report**

### **2.1 Upstream Analysis**

There is no proposed upstream basin. The project parcels are bordered by River Road to the north and 15<sup>th</sup> Street NW to the East. Both of these roads have their own collection system draining away from the project. The bordering commercial and residential areas have their own stormwater management systems and do not discharge onto the project site. Per the topographic survey performed on the existing site, along with field observations, the remaining parcels that border the proposed storage lot do not discharge any significant amount of stormwater onto the project site.

### **2.2 Downstream Analysis**

The commercial properties have onsite storm collection and conveyance systems. There were two storm sump pump stations identified in the northwest parking lot. These systems pumping north to the adjacent city system in River Road. The River Road system has a CB located on the east side of the northwest driveway entrance (STCB#1173), this CB has an 18" CMP culvert that drains north under River Road to an outlet above the Puyallup River.

The eastern parking lot drains south towards likely entering onsite depressions, the onsite storm system to the south, or connecting to the city system in 15<sup>th</sup> Street. The residential properties drain south to an existing onsite system that is in poor condition. This system draining east to the city system in 15<sup>th</sup> Street.

The undeveloped parcels and the parcels being used for parking has an existing storm drainage system in poor condition. It is unknown where the site currently discharges its stormwater. No as-built information has been found on the two project parcels, though it appears that stormwater currently ponds until it infiltrates onsite. It appears that the majority of stormwater conveyance facilities within adjacent public rights-of-way discharge north to the Puyallup River. Projects that discharge surface water runoff indirectly to the Puyallup River, through a municipal storm sewer

system, are exempt from enhanced treatment and flow control requirements per Appendices I-C and I-E of the *SMMWW*. Refer to Sections 4.6 and 4.7 for information on the proposed water quality and flow control plans.

### **3.0 Permanent Stormwater Control Plan**

This project is a new development project that includes more than 5,000 square feet of impervious surfaces; therefore, all Minimum Requirements (MR) apply to this project. Refer to Appendix A, Exhibit A-5, for the Flow Chart for Determining Requirements for Redevelopment.

The existing stormwater facilities found onsite are to be removed and will not be utilized as part of the permanent stormwater control plan. A new system is proposed to collect all stormwater generated on the project site. These catch basins shall convey runoff south to a Biopod 8x24 Water Quality Structure for enhanced water quality treatment. From this proposed manhole, runoff shall be conveyed east toward 15<sup>th</sup> Street NW, where an existing 60-inch stormwater trunk line runs north, past River Road, and discharges into the Puyallup River. As discussed above in Section 2.2, due to this indirect discharge of stormwater into the Puyallup River through a municipal storm sewer system, no flow control or enhanced treatment is required for the project site, and Enhanced Treatment (as defined by the *SMMWW*) is proposed. Refer to Sections 4.6 and 4.7 for more information on the proposed water quality and flow control plans.

Refer to the Developed Conditions Map (Appendix A, Exhibit A-4) for the areas used to size the proposed water quality facility, and Appendix D for the WWHM modeling used to size the proposed StormFilter system.

## **4.0 Summary of Minimum Requirements**

### **4.1 MR 1 – Preparation of Stormwater Site Plans**

This report and the project plans represent the Stormwater Site Plan for this project and satisfy MR 1.

### **4.2 MR 2 - Construction Stormwater Pollution Prevention**

A Construction Stormwater Pollution Prevention Plan (CSWPPP) has been prepared to satisfy MR 2 and is included as Appendix E of this report.

### **4.3 MR 3 – Source Control of Pollution**

The proposed project is required to provide source control of pollution. Following are proposed measures to be implemented as part of the civil plans.

- All discharges to the city storm system require City of Puyallup approval.
- All pollutants, including waste materials and demolition debris created onsite during construction, shall be handled and disposed of in a manner that does not cause contamination of surface water.
- Cover, containment, and protection from vandalism shall be provided for all chemicals, liquid products, petroleum products, and non-inert wastes present on the site (see Chapter 173-304 WAC for the definition of inert waste).

- Maintenance and repair of heavy equipment and vehicles that may result in discharge or spillage of pollutants to the ground or into surface water runoff must be conducted using spill prevention measures such as drip pans.
- Concrete Handling (BMP C151) and Sawcutting and Surfacing Pollution (BMP C152) shall be used to prevent or treat contamination of surface water runoff by pH modifying sources.

The CSWPPP provides details on the control of pollution during construction.

#### **4.4 MR 4 – Preservation of Natural Drainage Systems and Outfalls**

The existing discharge location of the project parcels is unknown due to the poor condition of the existing stormwater facilities, though it has been assumed that runoff discharges to the Puyallup River. This assumed discharge location shall be maintained under developed conditions. Under proposed conditions, treated runoff is discharged east toward 15<sup>th</sup> Street NW, where it enters the existing public drainage system. This existing, public stormwater line is a 60-inch trunk line that discharges north directly to the Puyallup River.

#### **4.5 MR 5 – Onsite Stormwater Control**

Onsite stormwater management Best Management Practices (BMPs) are not practical for the site due to native site soils, which have low infiltration rates, and groundwater at 4.5-5.5', per the attached geotechnical report. Infiltration Basin or Trench are infeasible due to required 5' separation from seasonal high-water mark. Previous fuel tanks being located on the site were removed but the recommendation as part of the cleanup permit was to cap the site following the tank removal. This recommendation would not allow infiltration of stormwater.

Existing trees and vegetation will be retained along the southern boundary of the site. Refer to the landscaping plans for additional information.

A Biopod 8x24 Water Quality Structure is proposed for stormwater treatment. Refer to MR 6 for more information on the proposed runoff treatment facilities. Refer to MR 7 for a narrative describing how the project site is exempt from flow control requirements.

#### **4.6 MR 6 – Runoff Treatment**

Over 5,000 square feet of pollution-generating impervious surface (PGIS) will be added as part of these improvements; therefore, water quality treatment shall be provided. Enhanced water quality treatment is required for this site because it discharges stormwater through the existing 60-inch municipal storm sewer system underneath 15<sup>th</sup> Street NW, to the Puyallup River. Per Appendix I-C of the *SMMWW* (III-A in *2019 SWMMWW*), the Puyallup River is a Basic Treatment Receiving Water at the location of the project site, below the Carbon River.

#### **4.7 MR 7 – Flow Control**

The proposed stormwater system shall discharge runoff east to an existing 60-inch municipal storm sewer trunk line that runs under 15<sup>th</sup> Street NW and discharges north to the Puyallup River. Per Appendix I-E of the *SMMWW*, flow control is not required for runoff discharged, directly or indirectly, at least 0.5 mile downstream of the confluence with Kellog Creek. The project site is significantly downstream of this confluence, and therefore flow control is not required for the project site.

#### **4.8 MR 8 – Wetland Protection**

No wetlands will be affected by the proposed development. Developed runoff is discharged through a closed conveyance system to an existing municipal piped storm sewer system that runs north and discharges to the Puyallup River.

#### **4.9 MR 9 – Operation and Maintenance**

See Appendix C for a copy of the Operations and Maintenance Manual. This manual shall be readily available for inspection by the City of Puyallup. The maintenance and operations shall be the responsibility of the owner of the Larson River Road Storage project.

#### **5.0 Construction Stormwater Pollution Prevention Plan**

A Temporary Erosion Control Plan is included with the plan set, and a CSWPPP for the project is included as Appendix E of this report.

#### **6.0 Special Reports and Studies**

A geotechnical report was prepared by South Sound Geotechnical Consulting, dated May 5, 2016. Refer to Appendix B.

The project site is not within a 100-year flood plain, as seen in Appendix A, Exhibit A-6.

#### **7.0 Other Permits**

A State Environmental Policy Act (SEPA) Checklist has been completed for this project. A grading permit is required for this project by the City of Puyallup. Coverage under DOE's Construction Stormwater General Permit must be obtained.

#### **8.0 Operations and Maintenance Manual**

Refer to Appendix C for the Maintenance Standards for the proposed drainage facilities and the Maintenance Checklist for the finished project site.

#### **9.0 Conclusion**

Based on our understanding and the attached documentation, we believe the proposed improvements conform to City of Puyallup and Washington State Department of Ecology standards. We conclude that this project, as proposed, will not have adverse impacts to the site or the downstream drainage system.

This analysis is based on data and records either supplied to or obtained by AHBL. These documents are referenced within the text of the analysis. The analysis has been prepared using procedures and practices within the standard accepted practices of the industry.

AHBL, Inc.

Michael Hager, PE  
Project Engineer

MCH/DJO/lsk

May 2016  
Revised June 2021  
Revised June 2022

Q:\2016\2160102\10\_CIVNON\_CAD\REPORTS\SSP 20210319\20210319 Rpt (SSP) 2160102.10.docx

# Appendix A

---

## Exhibits

- A-1 .....Vicinity Map
- A-2 .....Existing Conditions Map
- A-3 .....NRCS Soil Survey
- A-4 .....Developed Conditions Map
- A-5 .....Flow Chart for Determining Requirements for Redevelopment
- A-6 .....FEMA Flood Map

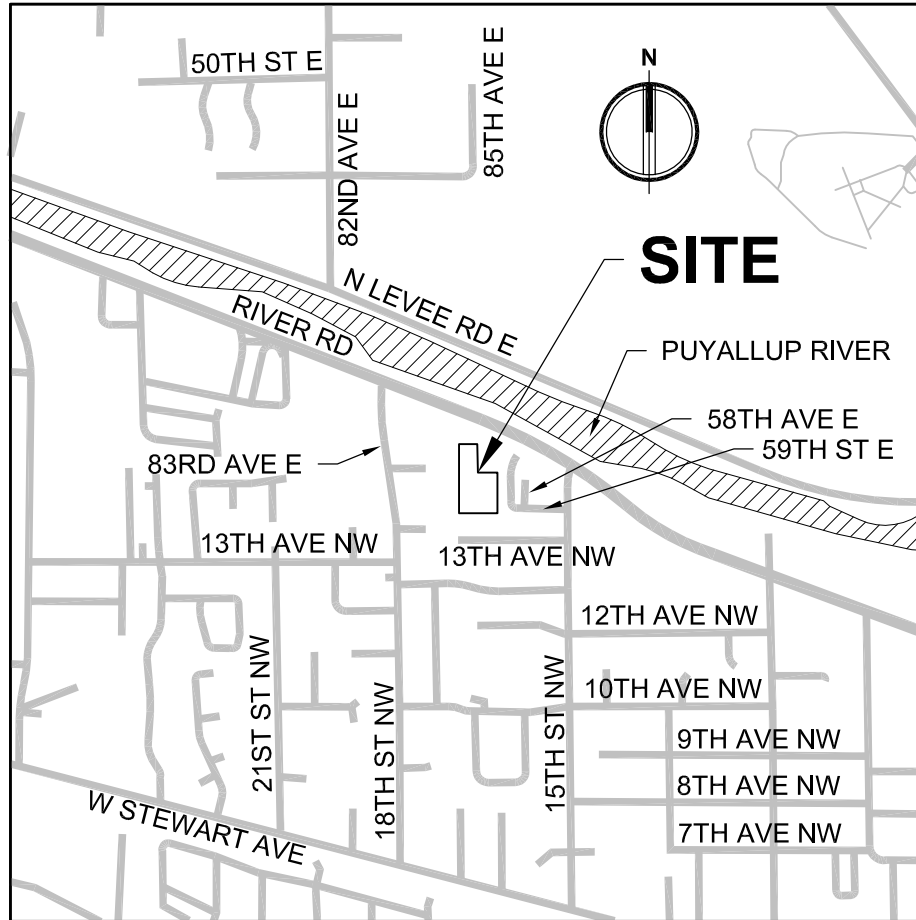

## VICINITY MAP

SCALE: 1" = 1/4 MILE (1320')



TACOMA-SEATTLE  
 2215 North 30th Street, Suite 300, Tacoma, WA 98403 253.383.2422 TEL.  
 316 Occidental Avenue South, Suite 320, Seattle, WA 98104 206.267.2425 TEL.

Civil Engineers  
 Structural Engineers  
 Landscape Architects  
 Community Planners  
 Land Surveyors  
 Neighbors

LARSON RIVER ROAD STORATE  
 2160102.10

**VICINITY MAP**  
**05/06/2016**

**A-1**



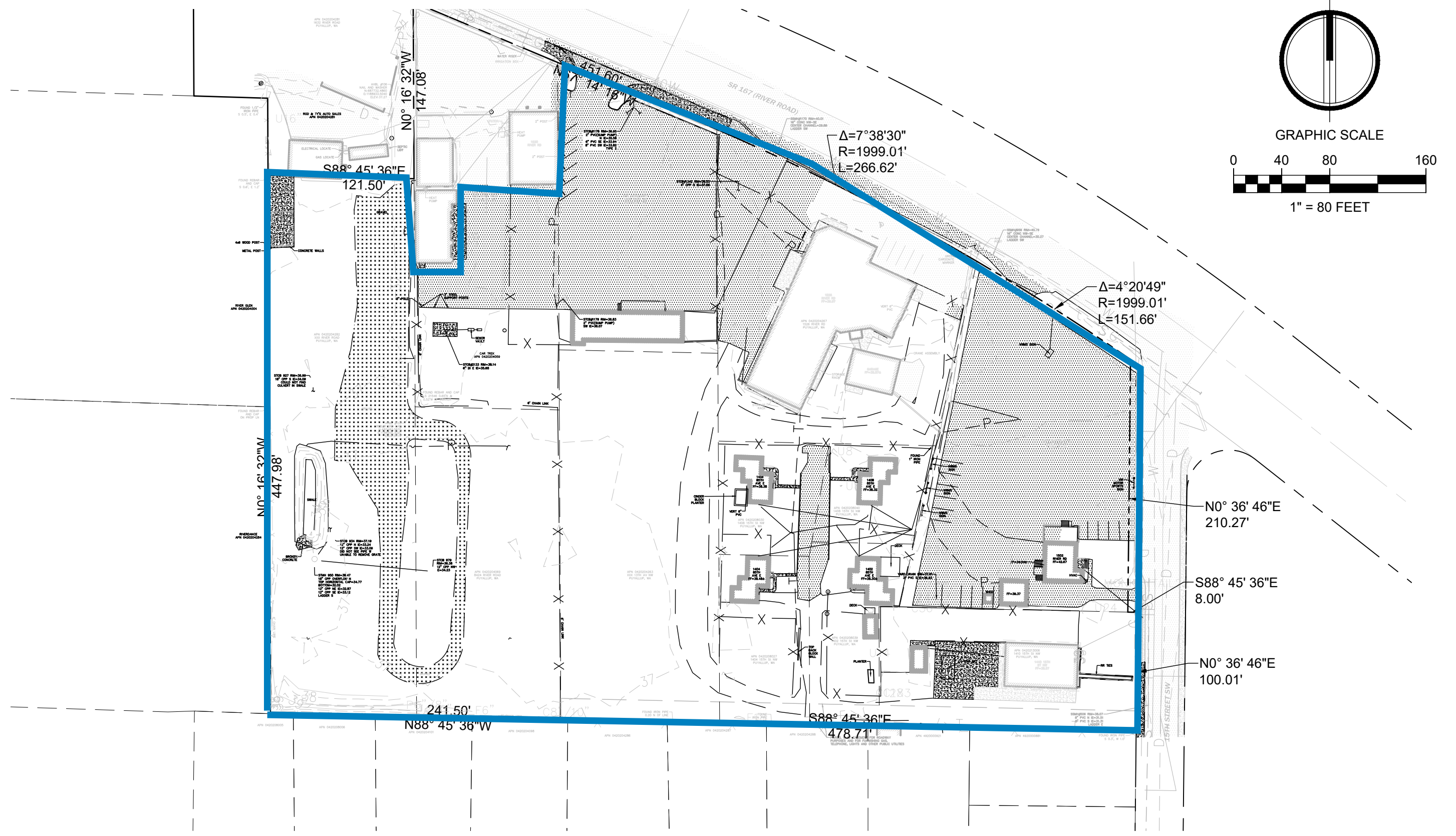
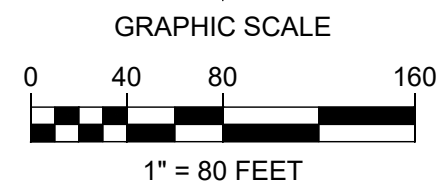
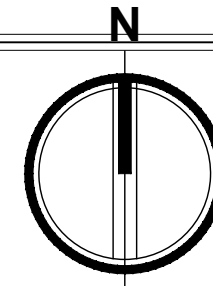

TACOMA • SEATTLE  
2215 North 30th Street, Suite 300, Tacoma, WA 98403 253.383.2422 TEL  
316 Occidental Avenue South, Suite 320, Seattle, WA 98104 206.267.2425 TEL

Civil Engineers  
Structural Engineers  
Landscape Architects  
Community Planners  
Land Surveyors  
Neighbors

LARSON RIVER ROAD STORAGE  
2160102.10  
**EXISTING CONDITIONS MAP**

**A-2**



Soil Map—Pierce County Area, Washington

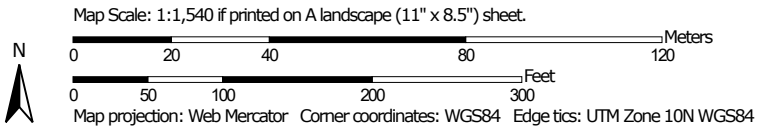

## MAP LEGEND

### Area of Interest (AOI)

 Area of Interest (AOI)

### Soils

 Soil Map Unit Polygons

 Soil Map Unit Lines

 Soil Map Unit Points

### Special Point Features



Blowout



Borrow Pit



Clay Spot



Closed Depression



Gravel Pit



Gravelly Spot



Landfill



Lava Flow



Marsh or swamp



Mine or Quarry



Miscellaneous Water



Perennial Water



Rock Outcrop



Saline Spot



Sandy Spot



Severely Eroded Spot



Sinkhole



Slide or Slip



Sodic Spot



Spoil Area



Stony Spot



Very Stony Spot



Wet Spot



Other



Special Line Features

### Water Features



Streams and Canals

### Transportation



Rails



Interstate Highways



US Routes



Major Roads



Local Roads

### Background



Aerial Photography

## MAP INFORMATION

The soil surveys that comprise your AOI were mapped at 1:24,000.

**Warning:** Soil Map may not be valid at this scale.

Enlargement of maps beyond the scale of mapping can cause misunderstanding of the detail of mapping and accuracy of soil line placement. The maps do not show the small areas of contrasting soils that could have been shown at a more detailed scale.

Please rely on the bar scale on each map sheet for map measurements.

Source of Map: Natural Resources Conservation Service  
 Web Soil Survey URL:  
 Coordinate System: Web Mercator (EPSG:3857)

Maps from the Web Soil Survey are based on the Web Mercator projection, which preserves direction and shape but distorts distance and area. A projection that preserves area, such as the Albers equal-area conic projection, should be used if more accurate calculations of distance or area are required.

This product is generated from the USDA-NRCS certified data as of the version date(s) listed below.

Soil Survey Area: Pierce County Area, Washington  
 Survey Area Data: Version 16, Jun 4, 2020

Soil map units are labeled (as space allows) for map scales 1:50,000 or larger.

Date(s) aerial images were photographed: Jul 29, 2018—Jul 22, 2019

The orthophoto or other base map on which the soil lines were compiled and digitized probably differs from the background imagery displayed on these maps. As a result, some minor shifting of map unit boundaries may be evident.

## Map Unit Legend

Map Unit Symbol	Map Unit Name	Acres in AOI	Percent of AOI
31A	Puyallup fine sandy loam	7.6	100.0%
<b>Totals for Area of Interest</b>		<b>7.6</b>	<b>100.0%</b>



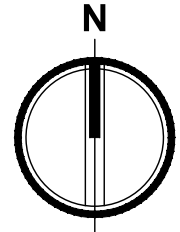

GRAPHIC SCALE

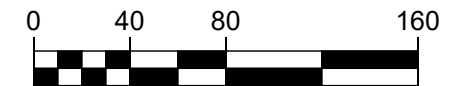

1" = 80 FEET

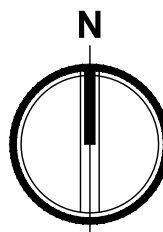

**AHBL**  
 TACOMA · SEATTLE  
 2215 North 30th Street, Suite 300, Tacoma, WA 98403 253.383.2422 TEL  
 316 Occidental Avenue South, Suite 320, Seattle, WA 98104 206.267.2425 TEL

*Civil Engineers  
 Structural Engineers  
 Landscape Architects  
 Community Planners  
 Land Surveyors  
 Neighbors*

LARSON RIVER ROAD STORAGE  
 2160102.10  
**DEVELOPED CONDITIONS**

**A-4**

**Figure I-3.2: Flow Chart for Determining Requirements for Redevelopment**

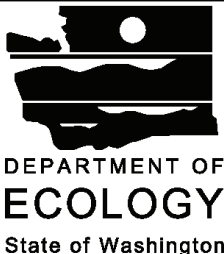
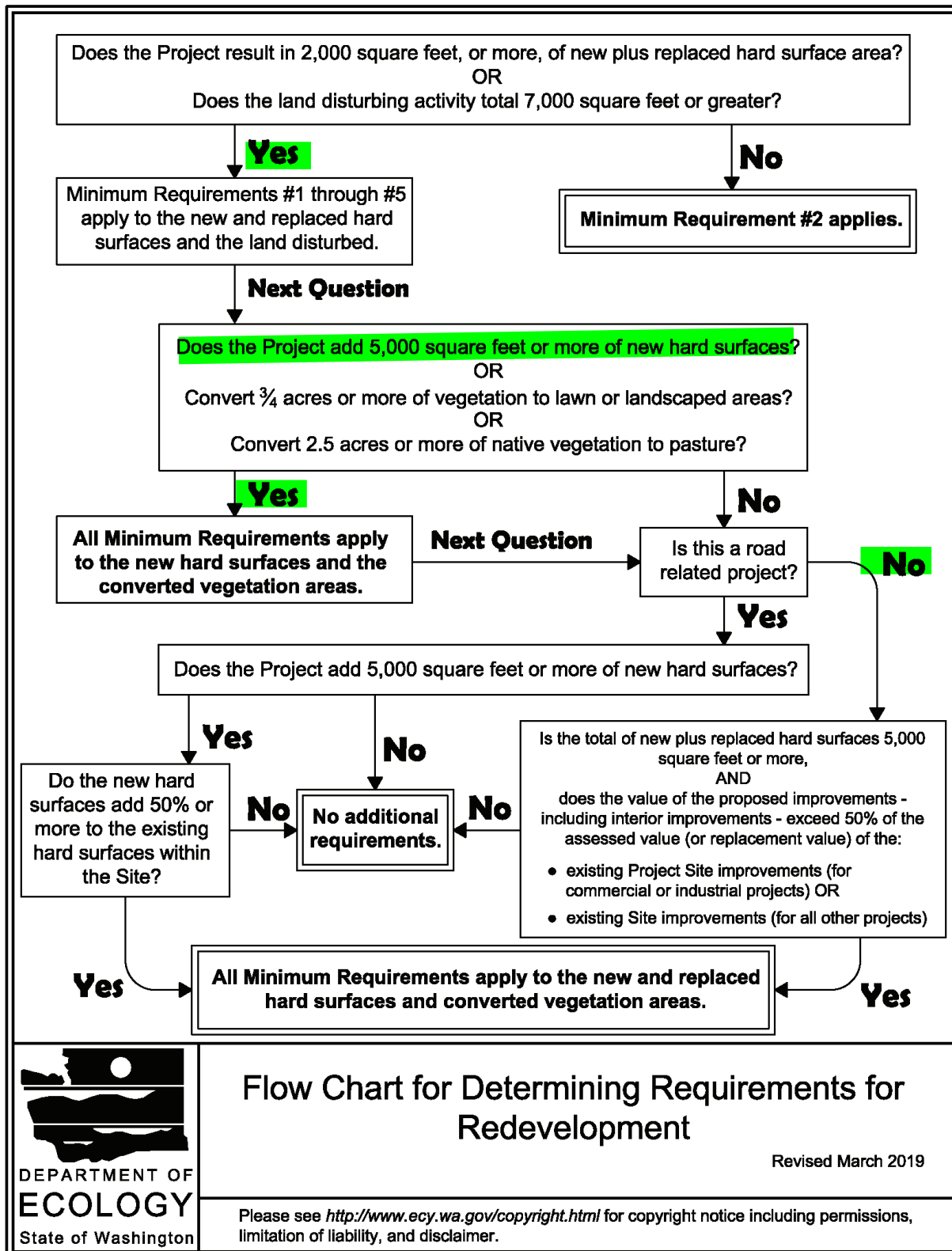

**Flow Chart for Determining Requirements for Redevelopment**

Revised March 2019

Please see <http://www.ecy.wa.gov/copyright.html> for copyright notice including permissions, limitation of liability, and disclaimer.

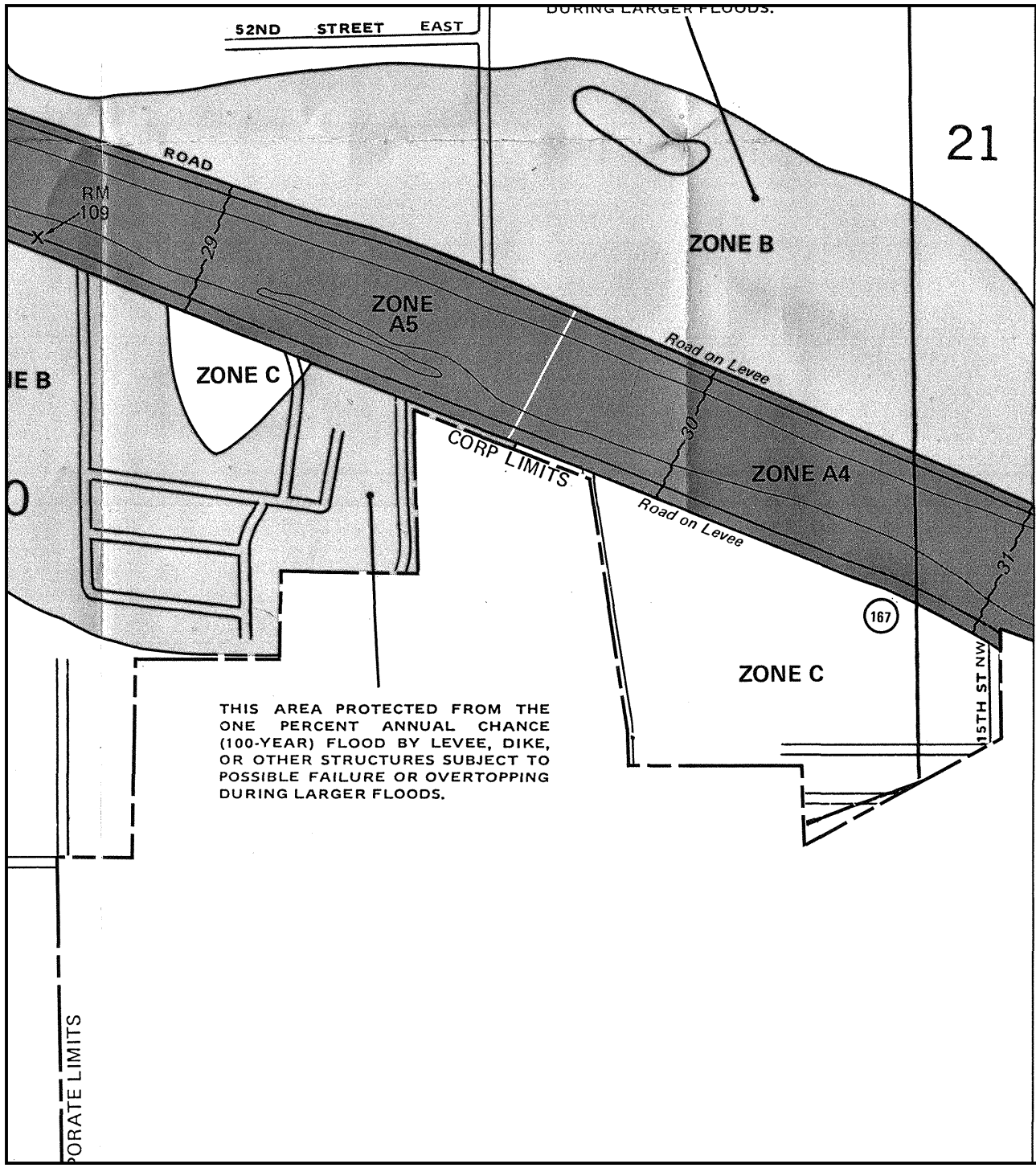

APPROXIMATE SCALE

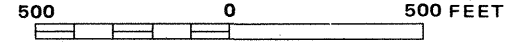

NATIONAL FLOOD INSURANCE PROGRAM

**FIRM**  
FLOOD INSURANCE RATE MAP

**PIERCE COUNTY,  
WASHINGTON**  
(UNINCORPORATED AREAS)

PANEL 329 OF 1375  
(SEE MAP INDEX FOR PANELS NOT PRINTED)

COMMUNITY-PANEL NUMBER  
530138 0329 C

EFFECTIVE DATE:  
AUGUST 19, 1987



Federal Emergency Management Agency

This is an official copy of a portion of the above referenced flood map. It was extracted using F-MIT On-Line. This map does not reflect changes or amendments which may have been made subsequent to the date on the title block. For the latest product information about National Flood Insurance Program flood maps check the FEMA Flood Map Store at [www.msc.fema.gov](http://www.msc.fema.gov)

# ***Appendix B***

---

- Geotechnical Engineering Report – South Sound Geotechnical Consulting



## **South Sound Geotechnical Consulting**

May 5, 2016

AHBL  
2215 North 30<sup>th</sup> Street, Suite 200  
Tacoma, Washington 98403-3350

Attention: Mr. Lucas Johnson, P.E.

Subject: Geotechnical Engineering Report  
Larson River Road Storage  
Puyallup, Washington  
SSGC Project No. 16025

Mr. Johnson,

South Sound Geotechnical Consulting (SSGC) has completed a geotechnical assessment for planned improvements to the Larson vehicle storage site on River Road in Puyallup, Washington. Our services have been completed in general conformance with our proposal (P16014) dated March 10, 2016 and authorized per AHBL subconsultant agreement dated March 22, 2016. Our scope of services included excavation of four test pits on the site, two infiltration test holes, engineering analyses, and preparation of this report.

### **PROJECT INFORMATION**

The car storage lot is located on the south side of the 1600 block of River Road. Plans include paving the site with conventional HMA asphalt concrete. Stormwater control will include infiltration facilities, if feasible.

### **SITE CONDITIONS**

The site is undeveloped and mostly covered with grass and isolated gravel areas. An existing pond several feet deep is in the center-western portion of the site with a manhole near the southern end of the pond. Overall, the site is generally level with an estimated elevation change of less than 2 feet, with the exception of the pond. Several catch basins are present in the yard area.

### **SUBSURFACE CONDITIONS**

Subsurface conditions were characterized by completing four (4) test pits and two (2) infiltration test holes on March 30, 2016. Approximate location of the test sites are shown on Figure 1, Exploration Plan. A summary description of observed subgrade conditions is provided below.

### **Soil Conditions**

Topsoil was below the surface in test pits TP-1 through TP-3 and extended to depths between about 6 to 8 inches. Loose crushed gravel fill was at the surface in test pit TP-4 and extended to a depth of about 1 foot. Fill consisting of silty sand to sand with silt and gravel was observed in the infiltration test holes and extended to depths between 1 and 2 feet. An approximate 6 inch topsoil layer was below the fill in infiltration test IT-1.

Native silty fine sand was below the topsoil (or fill) in the test pits. This soil was in a loose condition and extended to depths ranging from 1 to 3 feet below the surface. Medium stiff silt with fine sand and clay was observed below the silty sand and continued to the bottom of the test pits at depths between 5.5 to 6.5 feet below the surface. Similar native soils were observed in the infiltration test holes.

### **Groundwater Conditions**

Groundwater or seepage was observed at depths of about 4.5 to 5.5 feet in the test pits at the time of excavation. It should be anticipated that groundwater levels will fluctuate due to seasonal precipitation and on- and off-site drainage patterns.

### **Geologic Setting**

The USDA Soil Conservation Service Soil Map of Pierce County, Washington (1977) shows soils in this part of ~~Eatonville~~ mapped as Puyallup fine sandy loam. This soil reportedly formed in sandy mixed alluvium on natural levees. Native soils in the test holes appear to generally conform to the mapped soil type.

Puyallup



## **GEOTECHNICAL DESIGN CONSIDERATIONS**

Paving of the storage area is considered feasible based on observed soil conditions in the test pits completed. Conventional HMA pavements are suitable over properly prepared subgrades and gravel bases. However, infiltration test results and a relatively high groundwater table suggest infiltration for stormwater control is not feasible at this site.

Recommendations presented in the following sections should be considered general and may require modifications when earthwork and grading occur. They are based upon the subsurface conditions observed in the test pits and our understanding that finish site grades will be similar to existing grades. It should be noted that subsurface conditions across the site may vary from those depicted on the exploration logs and can change with time. Therefore, proper site preparation will depend upon the weather and soil conditions encountered at the time of construction. We recommend that SSGC review final plans and further assess subgrade and slope conditions at the time of construction, as warranted.

## **General Site Preparation**

Site grading and earthwork should include procedures to control surface water runoff. Earthwork without adequate drainage control measures may negatively impact site soils, resulting in increased export of impacted soil and import of fill materials, thereby potentially increasing the cost of the earthwork and subgrade preparation phases of the project.

Site grading should include removal (stripping) of existing fill and topsoil. We anticipate stripping depths to range from about 6 inches to 2 feet based on observed soils in the excavations, but should average less than 1 foot. Pavements subgrades should consist of native firm soils.

## **General Subgrade Preparation**

Following stripping we recommend that exposed subgrades are proofrolled using a large roller, loaded dump truck, or other equipment to assess subgrade conditions. Proofrolling efforts should result in the upper 1 foot of subgrade soils achieving a compaction level of at least 95 percent of the maximum dry density (MDD) per the ASTM D1557 test method. Wet, loose, or soft subgrades that cannot achieve this compaction level should be removed and replaced with structural fill. A representative of SSGC should be present to assess subgrade conditions during proofrolling.

## **Grading and Drainage**

Positive drainage should be provided during construction and maintained throughout the life of the development. Allowing surface water into road subgrades or utility trenches should be prevented.

## **Structural Fill Materials**

The suitability of soil for use as structural fill will depend on the gradation and moisture content of the soil when it is placed. Soils with higher fines content (soil fraction passing the U.S. No. 200 sieve) will become sensitive with higher moisture content. It is often difficult to achieve adequate compaction if soil moisture is outside of optimum condition for soils that contain more than about 5 percent fines.

Site Soils: Site soils will be very difficult to use as structural fill as the amount of fines (silt and clay) observed will make them moisture sensitive. They potentially could be used if allowed to dry to within optimal moisture content. Optimum moisture is considered within about +/- 2 percent of the moisture content required to achieve the maximum density per the ASTM D-1557 test method. If moisture content is higher or lower than optimum, soils would need to be dried or wetted prior to placement as structural fill.

Import Fill Materials: We recommend import structural fill placed during dry weather consist of material which meets the specifications for *Gravel Borrow* as described in Section 9-03.14(1) of the 2014 Washington State Department of Transportation (WSDOT) Specifications for Road,

Bridge, and Municipal Construction (Publication M 41-10). Gravel Borrow should be protected from disturbance if exposed to wet conditions after placement.

During wet weather, or for backfill on wet subgrades, import soil suitable for compaction in wetter conditions should be provided. Imported fill for use in wet conditions should generally conform to specifications for *Select Borrow* as described in Section 9-03.14(2), or *Crushed Surfacing* per Section 9-03.9(3) of the 2014 WSDOT M-41 manual, with the modification that a maximum of 5 percent by weight shall pass the U.S. No. 200 sieve for these soil types.

It should be noted that structural fill placement and compaction is weather-dependent. Delays due to inclement weather are common, even when using select granular fill. We recommend site grading and earthwork be scheduled for the drier months of the year.

### Structural Fill Placement

We recommend structural fill is placed in lifts not exceeding about 10 to 12 inches in loose measure. It may be necessary to adjust lift thickness based on site and fill conditions during placement and compaction. Structural fill should be compacted to attain the recommended levels presented in Table 1, Compaction Criteria.

**Table 1. Compaction Criteria**

Fill Application	Compaction Criteria*
Footing areas (below structures and retaining walls)	95 %
Upper 2 feet in pavement areas, slabs and sidewalks, and utility trenches	95 %
Below 2 feet in pavement areas, slabs and sidewalks, and utility trenches	92 %
Utility trenches or general fill in non-paved or -building areas	90 %

\*Per the ASTM D 1557 test method.

Trench backfill within about 2 feet of utility lines should not be over-compacted to reduce the risk of damage to the line. In some instances the top of the utility line may be within 2 feet of the surface. Backfill in these circumstances should be compacted to a firm and unyielding condition.

We recommend fill procedures include maintaining grades that promote drainage and do not allow ponding of water within the fill area. The contractor should protect compacted fill subgrades from disturbance during wet weather. In the event of rain during structural fill placement, the exposed fill surface should be allowed to dry prior to placement of additional fill. Alternatively, the wet soil can be removed. We recommend consideration be given to protecting haul routes and other high traffic areas with free-draining granular fill material (i.e. sand and gravel containing less than 5 percent fines) or

quarry spalls to reduce the potential for disturbance to the subgrade during inclement weather. Structural fill should not consist of frozen material.

### **Earthwork Procedures**

Conventional earthmoving equipment should be suitable for earthwork at this site. Earthwork may be difficult during periods of wet weather or if elevated soil moisture is present as the native fine grained soils will be easily disturbed. Excavated site soils may not be suitable as structural fill depending on the soil moisture content and weather conditions at the time of earthwork. If soils are stockpiled and wet weather is anticipated, the stockpile should be protected with securely anchored plastic sheeting. If stockpiled soils become unusable, it may become necessary to import clean, granular soils to complete wet weather site work.

Wet or disturbed subgrade soils should be over-excavated to expose firm, non-yielding, non-organic soils and backfilled with compacted structural fill. We recommend the earthwork portion of this project be completed during extended periods of dry weather. If earthwork is completed during the wet season (typically late October through May) it may be necessary to take extra measures to protect subgrade soils.

If earthwork takes place during freezing conditions, we recommend the exposed subgrade be allowed to thaw and be re-compacted prior to placing subsequent lifts of structural fill. Alternatively, the frozen soil can be removed to unfrozen soil and replaced with structural fill.

The contractor is responsible for designing and constructing stable, temporary excavations (including utility trenches) as required to maintain stability of both the excavation sides and bottom. Excavations should be sloped or shored in the interest of safety following local and federal regulations, including current OSHA excavation and trench safety standards. Temporary excavation cuts should be sloped at inclinations of 1.5H:1V (Horizontal:Vertical) or flatter, unless the contractor can demonstrate the safety of steeper inclinations. Deeper excavations that extend into the lower wet soils may require shoring to limit caving and loss of ground.

A qualified geotechnical engineer and material testing firm should be retained during the construction phase of the project to observe earthwork operations and to perform necessary tests and observations during subgrade preparation, placement and compaction of structural fill, and backfilling of excavations.

### **Pavements**

We understand concrete asphalt (HMA) pavements will be used. Subgrades for pavement areas should be prepared as described in the site and subgrade preparation, and structural fill sections of this report. Subgrade soils below pavements should be compacted to at least 95 percent of the maximum dry density (ASTM D 1557) within at least one foot of the base of the section. Subgrades below pavement sections should also be graded or crowned to promote drainage and not allow for ponding of water beneath the section. If drainage is not provided and ponding occurs, the subgrade soils could become saturated, lose

strength, and result in premature distress to the pavement. In addition, the pavement surfacing should also be graded to promote drainage and reduce the potential for ponding of water on the pavement surface.

Pavement section design has been prepared and is based on AASHTO design guidelines and the following assumed design parameters:

- 15-year life span;
- Estimated design life Equivalent Single Axle Loads (18 kips) of 50,000;
- Estimated subgrade CBR of 3;
- Terminal serviceability of 2.0; and,
- Level of reliability 85 percent.

Minimum recommended pavement sections for conventional pavement areas include:

**Table 2. Minimum Pavement Section**

Traffic Area	Minimum Recommended Pavement Section Thickness (inches)			
	Asphalt Concrete Surface <sup>1</sup>	Aggregate Base Course <sup>2</sup>	Subbase Aggregate <sup>3</sup>	Total
Access and General Parking	3	6	6	15

<sup>1</sup> 1/2 -inch nominal aggregate hot-mix asphalt (HMA) per WSDOT 9-03.8(1)

<sup>2</sup> Crushed Surfacing Base Course per WSDOT 9-03.9(3)

<sup>3</sup> Gravel Borrow per WSDOT 9-03.14(1) or Crushed Surfacing Base Course WSDOT 9-03.9(3)

The above recommended pavement section should be considered a minimum. Added life expectancy could be improved by providing a geotextile separation fabric (such as Mirafi 140N) between the prepared subgrade and subbase aggregate fill, or providing a thicker granular fill (subbase or base course) section. The purpose of the separation fabric is to maintain segregation of materials and limit the potential of the coarser fill from migrating into the softer native subgrade which can reduce the structural integrity of the granular fill section. Final pavement sections should conform to applicable City of Puyallup (or Pierce County) pavement standards. The estimated CBR value may not be suitable depending on actual subgrades encountered during construction which could affect the pavement sections.

**Pavement Maintenance**

The performance and lifespan of pavements can be significantly impacted by future maintenance. The above pavement sections represent minimum recommended thicknesses and, as such, periodic maintenance should be completed. Proper maintenance will slow the rate of pavement deterioration, and will improve pavement performance and life. Preventive maintenance consists of both localized maintenance (crack and joint sealing and patching) and global maintenance (surface

sealing). Added maintenance measures should be anticipated over the lifetime of the pavement section if any existing fill or topsoil is left in-place beneath pavement sections.

**Infiltration Characteristics**

Two (2) infiltration tests were performed in the proposed storm tract in the southern portion of the site. Tests were completed in general conformance with procedures outlined in the US EPA falling head procedure per the 2012 Pierce County Stormwater Management and Site Development Manual. The approximate locations of the tests are presented on Figure 1, Site Plan. Results of the infiltration tests are presented in Table 2.

**Table 2. Infiltration Test Results**

Infiltration Test No.	Depth of Test from surface (feet)	Uncorrected (Field) Infiltration Rate (in/hr)	Estimated Long-Term Infiltration Rate (in/hr)	Correction Factors* (Ft/Fg/Fp)
IT-1	3.5	0.51	0.11	(0.5/0.65/0.7)
IT-2	3.75	0.375	0.08	(0.5/0.65/0.7)

\*Correction Factors from the 2012 Pierce County Stormwater Management and Site Development Manual.

Results of the tests show native site soils have very low infiltration potential. Additionally, the groundwater table was within 1 to 2 feet of the bottom of the infiltration test sites. As such, it is not considered feasible to utilize infiltration facilities at this site.

**REPORT CONDITIONS**

This report has been prepared for the exclusive use of Larson Automotive Group and AHBL for specific application to the project discussed and has been prepared in accordance with generally accepted geotechnical engineering practices in the area. No warranties, either express or implied, are intended or made. The analysis and recommendations presented in this report are based on observed soil conditions and test results at the indicated locations, and from other geologic information discussed. This report does not reflect variations that may occur across the site, or due to the modifying effects of construction or weather. The nature and extent of such variations may not become evident until during or after construction. If variations appear, we should be immediately notified so that further evaluation and supplemental recommendations can be provided.

The scope of services for this project does not include any environmental or biological assessment of the site including identification or prevention of pollutants, hazardous materials, or conditions. Other studies should be completed if the owner is concerned about the potential for contamination or pollution.

Geotechnical Engineering Report  
Larson River Road Storage  
Puyallup, Washington  
SSGC Project No. 16025  
May 5, 2016

SSGC

We appreciate the opportunity to work with you on this project. Please contact us if additional information is required or we can be of further assistance.

Respectfully,

South Sound Geotechnical Consulting



Timothy H. Roberts, P.E., R.G.  
Member/Geotechnical Engineer

Attachments: Figure 1 – Exploration Plan  
Appendix A – Field Exploration Procedures  
Unified Soil Classification System





**Legend**

**TP - 1**

 **Approximate Test Pit Location**

**IT - 1**

 **Approximate Infiltration Test**

Base map from Google Maps.

Scale: NTS

*South Sound* Geotechnical Consulting

P.O. Box 39500  
Lakewood, WA 98496  
(253) 973-0515

**Figure 1 – Exploration Plan**

**Larson River Road Storage  
Puyallup, WA**

SSGC Project #16025

Test Pit TP-1

Depth (feet)

Material Description

0 – 0.67

**Topsoil:** Sandy SILT with organics: Loose, moist, dark brown.

0.67 – 3

Silty fine SAND: Medium dense, moist, brown. (Sample S-1 @ 2.5 feet)

3 – 6.5

SILT with fine sand and clay: Medium stiff, moist, gray with orange mottling. (Sample S-2 @ 3.5 feet)

Test pit completed at approximately 6.5 feet on 3/30/16.  
Groundwater observed at about 4.5 feet at time of excavation.  
No caving observed at time of excavation.  
Approximate surface elevation: 37 feet

Test Pit TP-2

Depth (feet)

Material Description

0 – 0.5

**Topsoil:** Sandy SILT with organics: Loose, moist, dark brown.

0.5 – 1

Silty fine SAND: Medium dense, moist, brown.

1 - 6

SILT with fine sand and clay: Medium stiff, moist, gray with orange mottling.

Test pit completed at approximately 6.5 feet on 3/30/16.  
Groundwater observed at about 4.5 feet at time of excavation.  
No caving observed at time of excavation.  
Approximate surface elevation: 37 feet

Test Pit TP-3

Depth (feet)

Material Description

0 – 0.67

**Topsoil:** Sandy SILT with organics: Loose, moist, dark brown.

0.67 – 2

Silty fine SAND: Medium dense, moist, orange/gray.

2 - 6

SILT with fine sand and clay: Medium stiff, moist, mottled brown/gray. Fine sand seam between 4 and 5 feet. Grades wet at 4 feet.

Test pit completed at approximately 6 feet on 3/30/16.  
Groundwater observed at about 5 feet at time of excavation.  
No caving observed at time of excavation.  
Approximate surface elevation: 37 feet

Test Pit TP-4

Depth (feet)

Material Description

0 – 1

**Fill:** Sandy GRAVEL: Loose, moist, gray.

1 – 2

Silty fine SAND: Medium dense, moist, orange/gray.

2 – 5.5

SILT with fine sand and clay: Medium stiff, moist, mottled brown/gray. Fine sand seam between 4.5 and 5 feet. Grades wet at 4.5 feet.

Test pit completed at approximately 5.5 feet on 3/30/16.  
Groundwater observed at about 4.5 feet at time of excavation.  
No caving observed at time of excavation.  
Approximate surface elevation: 37 feet

## Appendix A

### Field Exploration Procedures

### **Field Exploration Procedures**

Our field exploration for this project included four (4) test pits and two (2) infiltration test holes completed on March 30, 2016. The approximate locations of the explorations are shown on Figure 1, Exploration Plan. The exploration locations were determined by pacing from site features. Ground surface elevations referenced on the logs were inferred from a site plan figure prepared by AHBL. The locations and elevations should be considered accurate only to the degree implied by the means and methods used.

An excavating contractor subcontracted to SSGC excavated the test pits and infiltration test holes. Soil samples were collected and stored in moisture tight containers for further assessment. Explorations were backfilled with excavated soils and tamped when completed. Please note that backfill in the explorations will likely settle with time. Backfill material in the test pits located in pavement or building areas should be re-excavated and recompact, or replaced with structural fill.

The following logs indicate the observed lithology of soils and other materials observed in the explorations at the time of excavation. Where a soil contact was observed to be gradational, our log indicates the average contact depth. Our logs also indicate the approximate depth to groundwater (where observed at the time of excavation), along with sample numbers and approximate sample depths. Soil descriptions on the logs are based on the Unified Soil Classification System.

# UNIFIED SOIL CLASSIFICATION SYSTEM

## Criteria for Assigning Group Symbols and Group Names Using Laboratory Tests<sup>A</sup>

				Soil Classification		
				Group Symbol	Group Name <sup>B</sup>	
Coarse Grained Soils More than 50% retained on No. 200 sieve	Gravels More than 50% of coarse fraction retained on No. 4 sieve	Clean Gravels Less than 5% fines <sup>C</sup>	$Cu \geq 4$ and $1 \leq Cc \leq 3^E$	GW	Well-graded gravel <sup>F</sup>	
			$Cu < 4$ and/or $1 > Cc > 3^E$	GP	Poorly graded gravel <sup>F</sup>	
	Sands 50% or more of coarse fraction passes No. 4 sieve	Gravels with Fines More than 12% fines <sup>C</sup>	Clean Sands Less than 5% fines <sup>D</sup>	Fines classify as ML or MH Fines classify as CL or CH	GM	Silty gravel <sup>F,G,H</sup>
			Sands with Fines More than 12% fines <sup>D</sup>	$Cu \geq 6$ and $1 \leq Cc \leq 3^E$ $Cu < 6$ and/or $1 > Cc > 3^E$	GC	Clayey gravel <sup>F,G,H</sup>
			Clean Sands Less than 5% fines <sup>D</sup>	$Cu \geq 6$ and $1 \leq Cc \leq 3^E$ $Cu < 6$ and/or $1 > Cc > 3^E$	SW	Well-graded sand <sup>I</sup>
			Sands with Fines More than 12% fines <sup>D</sup>	Fines classify as ML or MH Fines Classify as CL or CH	SP	Poorly graded sand <sup>I</sup>
Fine-Grained Soils 50% or more passes the No. 200 sieve	Sils and Clays Liquid limit less than 50	inorganic	$PI > 7$ and plots on or above "A" line <sup>J</sup> $PI < 4$ or plots below "A" line <sup>J</sup>	CL	Lean clay <sup>K,L,M</sup>	
		organic	Liquid limit - oven dried < 0.75 Liquid limit - not dried	ML	Silt <sup>K,L,M</sup>	
	Sils and Clays Liquid limit 50 or more	inorganic	$PI$ plots on or above "A" line $PI$ plots below "A" line	CH	Fat clay <sup>K,L,M</sup>	
		organic	Liquid limit - oven dried < 0.75 Liquid limit - not dried	OH	Organic clay <sup>K,L,M,P</sup> Organic silt <sup>K,L,M,Q</sup>	
		inorganic	$PI$ plots on or above "A" line $PI$ plots below "A" line	MH	Elastic Silt <sup>K,L,M</sup>	
		organic	Liquid limit - oven dried < 0.75 Liquid limit - not dried	OH	Organic clay <sup>K,L,M,P</sup> Organic silt <sup>K,L,M,Q</sup>	
Highly organic soils	Primarily organic matter, dark in color, and organic odor			PT	Peat	

<sup>A</sup>Based on the material passing the 3-in. (75-mm) sieve

<sup>B</sup>If field sample contained cobbles or boulders, or both, add "with cobbles or boulders, or both" to group name.

<sup>C</sup>Gravels with 5 to 12% fines require dual symbols: GW-GM well-graded gravel with silt, GW-GC well-graded gravel with clay, GP-GM poorly graded gravel with silt, GP-GC poorly graded gravel with clay.

<sup>D</sup>Sands with 5 to 12% fines require dual symbols: SW-SM well-graded sand with silt, SW-SC well-graded sand with clay, SP-SM poorly graded sand with silt, SP-SC poorly graded sand with clay

$$^E Cu = D_{60}/D_{10} \quad Cc = \frac{(D_{30})^2}{D_{10} \times D_{60}}$$

<sup>F</sup>If soil contains  $\geq 15\%$  sand, add "with sand" to group name.

<sup>G</sup>If fines classify as CL-ML, use dual symbol GC-GM, or SC-SM.

<sup>H</sup>If fines are organic, add "with organic fines" to group name.

<sup>I</sup>If soil contains  $\geq 15\%$  gravel, add "with gravel" to group name.

<sup>J</sup>If Atterberg limits plot in shaded area, soil is a CL-ML, silty clay.

<sup>K</sup>If soil contains 15 to 29% plus No. 200, add "with sand" or "with gravel," whichever is predominant.

<sup>L</sup>If soil contains  $\geq 30\%$  plus No. 200 predominantly sand, add "sandy" to group name.

<sup>M</sup>If soil contains  $\geq 30\%$  plus No. 200, predominantly gravel, add "gravelly" to group name.

<sup>N</sup> $PI \geq 4$  and plots on or above "A" line.

<sup>O</sup> $PI < 4$  or plots below "A" line.

<sup>P</sup> $PI$  plots on or above "A" line.

<sup>Q</sup> $PI$  plots below "A" line.

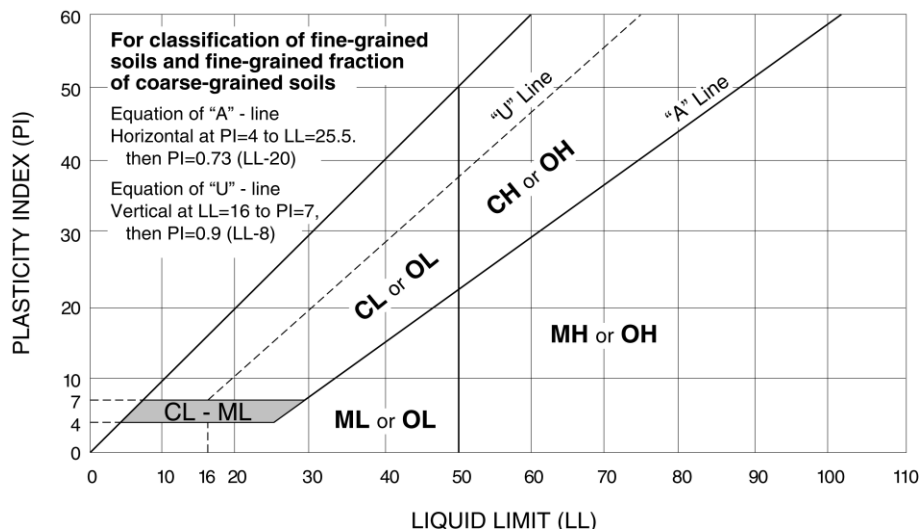

# ***Appendix C***

---

## **Maintenance Report**

- Attachment A: Maintenance Checklist
- Attachment B: Source Control BMPs

#### **4.6 Maintenance Standards for Drainage Facilities**

The facility-specific maintenance standards contained in this section are intended to be conditions for determining if maintenance actions are required as identified through inspection. They are not intended to be measures of the facility's required condition at all times between inspections. In other words, exceedence of these conditions at any time between inspections and/or maintenance does not automatically constitute a violation of these standards. However, based upon inspection observations, the inspection and maintenance schedules shall be adjusted to minimize the length of time that a facility is in a condition that requires a maintenance action.

**Table 4.5 – Maintenance Standards**



## No. 5 – Catch Basins

Maintenance Component	Defect	Conditions When Maintenance is Needed	Results Expected When Maintenance is performed
General	Trash & Debris	Trash or debris which is located immediately in front of the catch basin opening or is blocking inletting capacity of the basin by more than 10%.	No Trash or debris located immediately in front of catch basin or on grate opening.
		Trash or debris (in the basin) that exceeds 60 percent of the sump depth as measured from the bottom of basin to invert of the lowest pipe into or out of the basin, but in no case less than a minimum of six inches clearance from the debris surface to the invert of the lowest pipe.	No trash or debris in the catch basin.
		Trash or debris in any inlet or outlet pipe blocking more than 1/3 of its height.	Inlet and outlet pipes free of trash or debris.
		Dead animals or vegetation that could generate odors that could cause complaints or dangerous gases (e.g., methane).	No dead animals or vegetation present within the catch basin.
	Sediment	Sediment (in the basin) that exceeds 60 percent of the sump depth as measured from the bottom of basin to invert of the lowest pipe into or out of the basin, but in no case less than a minimum of 6 inches clearance from the sediment surface to the invert of the lowest pipe.	No sediment in the catch basin
	Structure Damage to Frame and/or Top Slab	Top slab has holes larger than 2 square inches or cracks wider than 1/4 inch  (Intent is to make sure no material is running into basin).	Top slab is free of holes and cracks.
		Frame not sitting flush on top slab, i.e., separation of more than 3/4 inch of the frame from the top slab. Frame not securely attached	Frame is sitting flush on the riser rings or top slab and firmly attached.
	Fractures or Cracks in Basin Walls/ Bottom	Maintenance person judges that structure is unsound.	Basin replaced or repaired to design standards.
		Grout fillet has separated or cracked wider than 1/2 inch and longer than 1 foot at the joint of any inlet/outlet pipe or any evidence of soil particles entering catch basin through cracks.	Pipe is regouted and secure at basin wall.
	Settlement/ Misalignment	If failure of basin has created a safety, function, or design problem.	Basin replaced or repaired to design standards.
	Vegetation	Vegetation growing across and blocking more than 10% of the basin opening.	No vegetation blocking opening to basin.
		Vegetation growing in inlet/outlet pipe joints that is more than six inches tall and less than six inches apart.	No vegetation or root growth present.

## No. 5 – Catch Basins

Maintenance Component	Defect	Conditions When Maintenance is Needed	Results Expected When Maintenance is performed
	Contamination and Pollution	See "Detention Ponds" (No. 1).	No pollution present.
Catch Basin Cover	Cover Not in Place	Cover is missing or only partially in place. Any open catch basin requires maintenance.	Catch basin cover is closed
	Locking Mechanism Not Working	Mechanism cannot be opened by one maintenance person with proper tools. Bolts into frame have less than 1/2 inch of thread.	Mechanism opens with proper tools.
	Cover Difficult to Remove	One maintenance person cannot remove lid after applying normal lifting pressure.  (Intent is keep cover from sealing off access to maintenance.)	Cover can be removed by one maintenance person.
Ladder	Ladder Rungs Unsafe	Ladder is unsafe due to missing rungs, not securely attached to basin wall, misalignment, rust, cracks, or sharp edges.	Ladder meets design standards and allows maintenance person safe access.
Metal Grates (If Applicable)	Grate opening Unsafe	Grate with opening wider than 7/8 inch.	Grate opening meets design standards.
	Trash and Debris	Trash and debris that is blocking more than 20% of grate surface inletting capacity.	Grate free of trash and debris.
	Damaged or Missing.	Grate missing or broken member(s) of the grate.	Grate is in place and meets design standards.

## No. 6 – Debris Barriers (e.g., Trash Racks)

Maintenance Components	Defect	Condition When Maintenance is Needed	Results Expected When Maintenance is Performed
General	Trash and Debris	Trash or debris that is plugging more than 20% of the openings in the barrier.	Barrier cleared to design flow capacity.
Metal	Damaged/ Missing Bars.	Bars are bent out of shape more than 3 inches.	Bars in place with no bends more than 3/4 inch.
		Bars are missing or entire barrier missing.	Bars in place according to design.
		Bars are loose and rust is causing 50% deterioration to any part of barrier.	Barrier replaced or repaired to design standards.
	Inlet/Outlet Pipe	Debris barrier missing or not attached to pipe	Barrier firmly attached to pipe

## No. 15 – Stormfilter™ (leaf compost filter)

Maintenance Component	Defect	Condition When Maintenance is Needed	Results Expected When Maintenance is Performed
Below Ground Vault	Sediment Accumulation on Media.	Sediment depth exceeds 0.25-inches.	No sediment deposits which would impede permeability of the compost media.
	Sediment Accumulation in Vault	Sediment depth exceeds 6-inches in first chamber.	No sediment deposits in vault bottom of first chamber.
	Trash/Debris Accumulation	Trash and debris accumulated on compost filter bed.	Trash and debris removed from the compost filter bed.
	Sediment in Drain Pipes/Clean-Outs	When drain pipes, clean-outs, become full with sediment and/or debris.	Sediment and debris removed.
	Damaged Pipes	Any part of the pipes that are crushed or damaged due to corrosion and/or settlement.	Pipe repaired and/or replaced.
	Access Cover Damaged/Not Working	Cover cannot be opened; one person cannot open the cover using normal lifting pressure, corrosion/deformation of cover.	Cover repaired to proper working specifications or replaced.
	Vault Structure Includes Cracks in Wall, Bottom, Frame and/or Top Slab	Cracks wider than 1/2-inch or evidence of soil particles entering the structure through the cracks, or maintenance/inspection personnel determine that the vault is not structurally sound.	Vault replaced or repairs made so that vault meets design specifications and is structurally sound.
		Cracks wider than 1/2-inch at the joint of any inlet/outlet pipe or evidence of soil particles entering through the cracks.	Vault repaired so that no cracks exist wider than 1/4-inch at the joint of the inlet/outlet pipe.
	Baffles	Baffles corroding, cracking warping, and/or showing signs of failure as determined by maintenance/inspection person.	Baffles repaired or replaced to specifications.
Access Ladder Damaged	Ladder is corroded or deteriorated, not functioning properly, not securely attached to structure wall, missing rungs, cracks, and misaligned.	Ladder replaced or repaired and meets specifications, and is safe to use as determined by inspection personnel.	
Below Ground Cartridge Type	Compost Media	Drawdown of water through the media takes longer than 1 hour, and/or overflow occurs frequently.	Media cartridges replaced.
	Short Circuiting	Flows do not properly enter filter cartridges.	Filter cartridges replaced.

## No. 18 – Catchbasin Inserts

Maintenance Component	Defect	Conditions When Maintenance is Needed	Results Expected When Maintenance is Performed
General	Sediment Accumulation	When sediment forms a cap over the insert media of the insert and/or unit.	No sediment cap on the insert media and its unit.
	Trash and Debris Accumulation	Trash and debris accumulates on insert unit creating a blockage/restriction.	Trash and debris removed from insert unit. Runoff freely flows into catch basin.
	Media Insert Not Removing Oil	Effluent water from media insert has a visible sheen.	Effluent water from media insert is free of oils and has no visible sheen.
	Media Insert Water Saturated	Catch basin insert is saturated with water and no longer has the capacity to absorb.	Remove and replace media insert
	Media Insert-Oil Saturated	Media oil saturated due to petroleum spill that drains into catch basin.	Remove and replace media insert.
	Media Insert Use Beyond Normal Product Life	Media has been used beyond the typical average life of media insert product.	Remove and replace media at regular intervals, depending on insert product.

**BMPs for Dust Control at Disturbed Land Areas and Unpaved Roadways and Parking Lots**

**Description of Pollutant Sources:** Dust can cause air and water pollution problems particularly at demolition sites and in arid areas where reduced rainfall exposes soil particles to transport by air.

**Pollutant Control Approach:** Minimize dust generation and apply environmentally friendly and government approved dust suppressant chemicals, if necessary.

**Applicable Operational BMPs:**

- Sprinkle or wet down soil or dust with water as long as it does not result in a wastewater discharge.
- Use only local and/or state government approved dust suppressant chemicals such as those listed in Ecology Publication #96-433, “Techniques for Dust Prevention and Suppression.”
- Avoid excessive and repeated applications of dust suppressant chemicals. Time the application of dust suppressants to avoid or minimize their wash-off by rainfall or human activity such as irrigation.
- Apply stormwater containment to prevent the conveyance of stormwater TSS into storm drains or receiving waters.
- The use of motor oil for dust control is prohibited. Care should be taken when using lignin derivatives and other high BOD chemicals in excavations or areas easily accessible to surface water or ground water.
- Consult with the Ecology Regional Office in your area on discharge permit requirements if the dust suppression process results in a wastewater discharge to the ground, ground water, storm drain, or surface water.

**Recommended Additional Operational BMPs for Roadways and Other Trafficked Areas:**

- Consider limiting use of off-road recreational vehicles on dust generating land.
- Consider paving unpaved permanent roads and other trafficked areas at municipal, commercial, and industrial areas.
- Consider paving or stabilizing shoulders of paved roads with gravel, vegetation, or local government approved chemicals.
- Encourage use of alternate paved routes, if available.
- Vacuum or wet sweep fine dirt and skid control materials from paved roads soon after winter weather ends or when needed.
- Consider using traction sand that is pre-washed to reduce dust emissions.

**Additional Recommended Operational BMPs for Dust Generating Areas:**

- Prepare a dust control plan. Helpful references include: Control of Open Fugitive Dust Sources (EPA-450/3-88-088), and Fugitive Dust Background Document and Technical Information Document for Best Available Control Measures (EPA-450/2-92-004)
- Limit exposure of soil (dust source) as much as feasible.
- Stabilize dust-generating soil by growing and maintaining vegetation, mulching, topsoiling, and/or applying stone, sand, or gravel.
- Apply windbreaks in the soil such as trees, board fences, tarp curtains, bales of hay, etc.
- Cover dust-generating piles with wind-impervious fabric, or equivalent material.

## **BMPs for Landscaping and Lawn/Vegetation Management**

**Description of Pollutant Sources:** Landscaping can include grading, soil transfer, vegetation removal, pesticide and fertilizer applications, and watering. Stormwater contaminants include toxic organic compounds, heavy metals, oils, total suspended solids, coliform bacteria, fertilizers, and pesticides.

Lawn and vegetation management can include control of objectionable weeds, insects, mold, bacteria and other pests with chemical pesticides and is conducted commercially at commercial, industrial, and residential sites. Examples include weed control on golf course lawns, access roads, and utility corridors and during landscaping; sap stain and insect control on lumber and logs; rooftop moss removal; killing nuisance rodents; fungicide application to patio decks, and residential lawn/plant care. Toxic pesticides such as pentachlorophenol, carbamates, and organometallics can be released to the environment by leaching and dripping from treated parts, container leaks, product misuse, and outside storage of pesticide contaminated materials and equipment. Poor management of the vegetation and poor application of pesticides or fertilizers can cause appreciable stormwater contamination.

**Pollutant Control Approach:** Control of fertilizer and pesticide applications, soil erosion, and site debris to prevent contamination of stormwater.

Develop and implement an Integrated Pest Management Plan (IPM) and use pesticides only as a last resort. If pesticides/herbicides are used they must be carefully applied in accordance with label instructions on U.S. Environmental Protection Agency (EPA) registered materials. Maintain appropriate vegetation, with proper fertilizer application where practicable, to control erosion and the discharge of stormwater pollutants. Where practicable grow plant species appropriate for the site, or adjust the soil properties of the subject site to grow desired plant species.

### **Applicable Operational BMPs for Landscaping:**

- Install engineered soil/landscape systems to improve the infiltration and regulation of stormwater in landscaped areas.
- Do not dispose of collected vegetation into waterways or storm drainage systems.

### **Recommended Additional Operational BMPs for Landscaping:**

- Conduct mulch-mowing whenever practicable
- Dispose of grass clippings, leaves, sticks, or other collected vegetation, by composting, if feasible.

- Use mulch or other erosion control measures when soils are exposed for more than one week during the dry season or two days during the rainy season.
- If oil or other chemicals are handled, store and maintain appropriate oil and chemical spill cleanup materials in readily accessible locations. Ensure that employees are familiar with proper spill cleanup procedures.
- Till fertilizers into the soil rather than dumping or broadcasting onto the surface. Determine the proper fertilizer application for the types of soil and vegetation encountered.
- Till a topsoil mix or composted organic material into the soil to create a well-mixed transition layer that encourages deeper root systems and drought-resistant plants.
- Use manual and/or mechanical methods of vegetation removal rather than applying herbicides, where practical.

**Applicable Operational BMPs for the Use of Pesticides:**

- Develop and implement an IPM (See section on IPM at end of BMP) and use pesticides only as a last resort.
- Implement a pesticide-use plan and include at a minimum: a list of selected pesticides and their specific uses; brands, formulations, application methods and quantities to be used; equipment use and maintenance procedures; safety, storage, and disposal methods; and monitoring, record keeping, and public notice procedures. All procedures shall conform to the requirements of Chapter 17.21 RCW and Chapter 16-228 WAC (Appendix IV-D R.7).
- Choose the least toxic pesticide available that is capable of reducing the infestation to acceptable levels. The pesticide should readily degrade in the environment and/or have properties that strongly bind it to the soil. Any pest control used should be conducted at the life stage when the pest is most vulnerable. For example, if it is necessary to use a Bacillus thuringiensis application to control tent caterpillars, it must be applied before the caterpillars cocoon or it will be ineffective. Any method used should be site-specific and not used wholesale over a wide area.
- Apply the pesticide according to label directions. Under no conditions shall pesticides be applied in quantities that exceed manufacturer's instructions.
- Mix the pesticides and clean the application equipment in an area where accidental spills will not enter surface or ground waters, and will not contaminate the soil.



- Store pesticides in enclosed areas or in covered impervious containment. Ensure that pesticide contaminated stormwater or spills/leaks of pesticides are not discharged to storm drains. Do not hose down the paved areas to a storm drain or conveyance ditch. Store and maintain appropriate spill cleanup materials in a location known to all near the storage area.
- Clean up any spilled pesticides and ensure that the pesticide contaminated waste materials are kept in designated covered and contained areas.
- The pesticide application equipment must be capable of immediate shutoff in the event of an emergency.
- Do not spray pesticides within 100 feet of open waters including wetlands, ponds, and streams, sloughs and any drainage ditch or channel that leads to open water except when approved by Ecology or the local jurisdiction. All sensitive areas including wells, creeks and wetlands must be flagged prior to spraying.
- As required by the local government or by Ecology, complete public posting of the area to be sprayed prior to the application.
- Spray applications should only be conducted during weather conditions as specified in the label direction and applicable local and state regulations. Do not apply during rain or immediately before expected rain.

**Recommended Additional Operational BMPs for the use of pesticides:**

- Consider alternatives to the use of pesticides such as covering or harvesting weeds, substitute vegetative growth, and manual weed control/moss removal.
- Consider the use of soil amendments, such as compost, that are known to control some common diseases in plants, such as Pythium root rot, ashy stem blight, and parasitic nematodes. The following are three possible mechanisms for disease control by compost addition (USEPA Publication 530-F-9-044):
  1. Successful competition for nutrients by antibiotic production;
  2. Successful predation against pathogens by beneficial microorganism; and
  3. Activation of disease-resistant genes in plants by composts.

*Installing an amended soil/landscape system can preserve both the plant system and the soil system more effectively. This type of approach provides a soil/landscape system with adequate depth, permeability, and organic matter to sustain itself and continue working as an effective stormwater infiltration system and a sustainable nutrient cycle.*

- Once a pesticide is applied, its effectiveness should be evaluated for possible improvement. Records should be kept showing the applicability and inapplicability of the pesticides considered.
- An annual evaluation procedure should be developed including a review of the effectiveness of pesticide applications, impact on buffers and sensitive areas (including potable wells), public concerns, and recent toxicological information on pesticides used/proposed for use. If individual or public potable wells are located in the proximity of commercial pesticide applications contact the regional Ecology hydrogeologist to determine if additional pesticide application control measures are necessary.
- Rinseate from equipment cleaning and/or triple-rinsing of pesticide containers should be used as product or recycled into product.
- The application equipment used should be capable of immediate shutoff in the event of an emergency.

*For more information, contact the WSU Extension Home-Assist Program, (253) 445-4556, or Bio-Integral Resource Center (BIRC), P.O. Box 7414, Berkeley, CA.94707, or the Washington Department of Ecology to obtain "Hazardous Waste Pesticides" (Publication #89-41); and/or EPA to obtain a publication entitled "Suspended, Canceled and Restricted Pesticides" which lists all restricted pesticides and the specific uses that are allowed. Valuable information from these sources may also be available on the internet.*

#### **Applicable Operational BMPs for Vegetation Management:**

- Use at least an eight-inch "topsoil" layer with at least 8 percent organic matter to provide a sufficient vegetation-growing medium. Amending existing landscapes and turf systems by increasing the percent organic matter and depth of topsoil can substantially improve the permeability of the soil, the disease and drought resistance of the vegetation, and reduce fertilizer demand. This reduces the demand for fertilizers, herbicides, and pesticides. Organic matter is the least water-soluble form of nutrients that can be added to the soil. Composted organic matter generally releases only between 2 and 10 percent of its total nitrogen annually, and this release corresponds closely to the plant growth cycle. If natural plant debris and mulch are returned to the soil, this system can continue recycling nutrients indefinitely.
- Select the appropriate turfgrass mixture for your climate and soil type. Certain tall fescues and rye grasses resist insect attack because the symbiotic endophytic fungi found naturally in their tissues repel or kill common leaf and stem-eating lawn insects. They do not, however, repel root-feeding lawn pests such as Crane Fly larvae, and are toxic to ruminants such as cattle and sheep. The fungus causes no known

adverse effects to the host plant or to humans. Endophytic grasses are commercially available and can be used in areas such as parks or golf courses where grazing does not occur. The local Cooperative Extension office can offer advice on which types of grass are best suited to the area and soil type.

- Use the following seeding and planting BMPs, or equivalent BMPs to obtain information on grass mixtures, temporary and permanent seeding procedures, maintenance of a recently planted area, and fertilizer application rates: Temporary Seeding, Mulching and Matting, Clear Plastic Covering, Permanent Seeding and Planting, and Sodding as described in Volume II).
- Selection of desired plant species can be made by adjusting the soil properties of the subject site. For example, a constructed wetland can be designed to resist the invasion of reed canary grass by layering specific strata of organic matters (e.g., compost forest product residuals) and creating a mildly acidic pH and carbon-rich soil medium. Consult a soil restoration specialist for site-specific conditions.
- Aerate lawns regularly in areas of heavy use where the soil tends to become compacted. Aeration should be conducted while the grasses in the lawn are growing most vigorously. Remove layers of thatch greater than ¾-inch deep.
- Mowing is a stress-creating activity for turfgrass. When grass is mowed too short its productivity is decreased and there is less growth of roots and rhizomes. The turf becomes less tolerant of environmental stresses, more disease prone and more reliant on outside means such as pesticides, fertilizers and irrigation to remain healthy. Set the mowing height at the highest acceptable level and mow at times and intervals designed to minimize stress on the turf. Generally mowing only 1/3 of the grass blade height will prevent stressing the turf.

***Irrigation:***

- The depth from which a plant normally extracts water depends on the rooting depth of the plant. Appropriately irrigated lawn grasses normally root in the top 6 to 12 inches of soil; lawns irrigated on a daily basis often root only in the top 1 inch of soil. Improper irrigation can encourage pest problems, leach nutrients, and make a lawn completely dependent on artificial watering. The amount of water applied depends on the normal rooting depth of the turfgrass species used, the available water holding capacity of the soil, and the efficiency of the irrigation system. Consult with the local water utility, Conservation District, or Cooperative Extension office to help determine optimum irrigation practices.

### ***Fertilizer Management:***

- Turfgrass is most responsive to nitrogen fertilization, followed by potassium and phosphorus. Fertilization needs vary by site depending on plant, soil and climatic conditions. Evaluation of soil nutrient levels through regular testing ensures the best possible efficiency and economy of fertilization. For details on soils testing, contact the local Conservation District or Cooperative Extension Service.
- Fertilizers should be applied in amounts appropriate for the target vegetation and at the time of year that minimizes losses to surface and ground waters. Do not fertilize during a drought or when the soil is dry. Alternatively, do not apply fertilizers within three days prior to predicted rainfall. The longer the period between fertilizer application and either rainfall or irrigation, the less fertilizer runoff occurs.
- Use slow release fertilizers such as methylene urea, IDBU, or resin coated fertilizers when appropriate, generally in the spring. Use of slow release fertilizers is especially important in areas with sandy or gravelly soils.
- Time the fertilizer application to periods of maximum plant uptake. Generally fall and spring applications are recommended, although WSU turf specialists recommend four fertilizer applications per year.
- Properly trained persons should apply all fertilizers. At commercial and industrial facilities fertilizers should not be applied to grass swales, filter strips, or buffer areas that drain to sensitive water bodies unless approved by the local jurisdiction.

### ***Integrated Pest Management***

An IPM program might consist of the following steps:

Step 1: Correctly identify problem pests and understand their life cycle

Step 2: Establish tolerance thresholds for pests.

Step 3: Monitor to detect and prevent pest problems.

Step 4: Modify the maintenance program to promote healthy plants and discourage pests.

Step 5: Use cultural, physical, mechanical, or biological controls first if pests exceed the tolerance thresholds.

Step 6: Evaluate and record the effectiveness of the control and modify maintenance practices to support lawn or landscape recovery and prevent recurrence.

For an elaboration of these steps refer to Appendix IV-F.

## **BMPs for Maintenance and Repair of Vehicles and Equipment**

**Description of Pollutant Sources:** Pollutant sources include parts/vehicle cleaning, spills/leaks of fuel and other liquids, replacement of liquids, outdoor storage of batteries/liquids/parts, and vehicle parking.

**Pollutant Control Approach:** Control of leaks and spills of fluids using good housekeeping and cover and containment BMPs.

### **Applicable Operational BMPs:**

- Inspect for leaks all incoming vehicles, parts, and equipment stored temporarily outside.
- Use drip pans or containers under parts or vehicles that drip or that are likely to drip liquids, such as during dismantling of liquid containing parts or removal or transfer of liquids.
- Remove batteries and liquids from vehicles and equipment in designated areas designed to prevent stormwater contamination. Store cracked batteries in a covered non-leaking secondary containment system.
- Empty oil and fuel filters before disposal. Provide for proper disposal of waste oil and fuel.
- Do not pour/convey washwater, liquid waste, or other pollutant into storm drains or to surface water. Check with the local sanitary sewer authority for approval to convey to a sanitary sewer.
- Do not connect maintenance and repair shop floor drains to storm drains or to surface water. To allow for snowmelt during the winter a drainage trench with a sump for particulate collection can be installed and used only for draining the snowmelt and not for discharging any vehicular or shop pollutants.

### **Applicable Structural Source Control BMPs:**

- Conduct all maintenance and repair of vehicles and equipment in a building, or other covered impervious containment area that is sloped to prevent run-on of uncontaminated stormwater and runoff of contaminated stormwater.
- The maintenance of refrigeration engines in refrigerated trailers may be conducted in the parking area with due caution to avoid the release of engine or refrigeration fluids to storm drains or surface water.
- Park large mobile equipment, such as log stackers, in a designated contained area.

**For additional applicable BMPs** refer to the following BMPs: Fueling at Dedicated Stations; Washing and Steam Cleaning Vehicle/Equipment/Building Structures; Loading and Unloading Areas for Liquid or Solid Material; Storage of Liquids in Permanent Above-Ground Tanks; Storage of Liquid, Food Waste, or Dangerous Waste Containers;

Storage or Transfer (Outside) of Solid Raw Materials, By-Products, or Finished Products; Spills of Oil and Hazardous Substances; Illicit Connections to Storm Drains; and other BMPs provided in this chapter.

*Note that a treatment BMP is applicable for contaminated stormwater.*

**Applicable Treatment BMPs:** Contaminated stormwater runoff from vehicle staging and maintenance areas must be conveyed to a sanitary sewer, if allowed by the local sewer authority, or to an API or CP oil and water separator followed by a basic treatment BMP (See Volume V), applicable filter, or other equivalent oil treatment system.

**Recommended Additional Operational BMPs:**

- Consider storing damaged vehicles inside a building or other covered containment, until all liquids are removed. Remove liquids from vehicles retired for scrap.
- Clean parts with aqueous detergent based solutions or non-chlorinated solvents such as kerosene or high flash mineral spirits, and/or use wire brushing or sand blasting whenever practicable. Avoid using toxic liquid cleaners such as methylene chloride, 1,1,1-trichloroethane, trichloroethylene or similar chlorinated solvents. Choose cleaning agents that can be recycled.
- Inspect all BMPs regularly, particularly after a significant storm. Identify and correct deficiencies to ensure that the BMPs are functioning as intended.
- Avoid hosing down work areas. Use dry methods for cleaning leaked fluids.
- Recycle greases, used oil, oil filters, antifreeze, cleaning solutions, automotive batteries, hydraulic fluids, transmission fluids, and engine oils (see Appendix IV-C).
- Do not mix dissimilar or incompatible waste liquids stored for recycling.

## **BMPs for Maintenance of Stormwater Drainage and Treatment Systems**

**Description of Pollutant Sources:** Facilities include roadside catch basins on arterials and within residential areas, conveyance systems, detention facilities such as ponds and vaults, oil and water separators, biofilters, settling basins, infiltration systems, and all other types of stormwater treatment systems presented in Volume V. Roadside catch basins can remove from 5 to 15 percent of the pollutants present in stormwater. When catch basins are about 60 percent full of sediment, they cease removing sediments. Oil and grease, hydrocarbons, debris, heavy metals, sediments and contaminated water are found in catch basins, oil and water separators, settling basins, etc.

**Pollutant Control Approach:** Provide maintenance and cleaning of debris, sediments, and oil from stormwater collection, conveyance, and treatment systems to obtain proper operation.

### **Applicable Operational BMPs:**

Maintain stormwater treatment facilities according to the O & M procedures presented in Section 4.6 of Volume V in addition to the following BMPs:

- Inspect and clean treatment BMPs, conveyance systems, and catch basins as needed, and determine whether improvements in O & M are needed.
- Promptly repair any deterioration threatening the structural integrity of the facilities. These include replacement of clean-out gates, catch basin lids, and rock in emergency spillways.
- Ensure that storm sewer capacities are not exceeded and that heavy sediment discharges to the sewer system are prevented.
- Regularly remove debris and sludge from BMPs used for peak-rate control, treatment, etc. and discharge to a sanitary sewer if approved by the sewer authority, or truck to a local or state government approved disposal site.
- Clean catch basins when the depth of deposits reaches 60 percent of the sump depth as measured from the bottom of basin to the invert of the lowest pipe into or out of the basin. However, in no case should there be less than six inches clearance from the debris surface to the invert of the lowest pipe. Some catch basins (for example, WSDOT Type 1L basins) may have as little as 12 inches sediment storage below the invert. These catch basins will need more frequent inspection and cleaning to prevent scouring. Where these catch basins are part of a stormwater collection and treatment system, the system owner/operator may choose to concentrate maintenance efforts on downstream control devices as part of a systems approach.

- Clean woody debris in a catch basin as frequently as needed to ensure proper operation of the catchbasin.
- Post warning signs; “Dump No Waste - Drains to Ground Water,” “Streams,” “Lakes,” or emboss on or adjacent to all storm drain inlets *where practical*.
- Disposal of sediments and liquids from the catch basins must comply with “Recommendations for Management of Street Wastes” described in Appendix IV-G of this volume.

**Additional Applicable BMPs:** Select additional applicable BMPs from this chapter depending on the pollutant sources and activities conducted at the facility. Those BMPs include:

- BMPs for Soil Erosion and Sediment Control at Industrial Sites
- BMPs for Storage of Liquid, Food Waste, or Dangerous Waste Containers
- BMPs for Spills of Oil and Hazardous Substances
- BMPs for Illicit Connections to Storm Drains
- BMPs for Urban Streets.



## **BMPs for Mobile Fueling of Vehicles and Heavy Equipment**

**Description of Pollutant Sources:** Mobile fueling, also known as fleet fueling, wet fueling, or wet hosing, is the practice of filling fuel tanks of vehicles by tank trucks that are driven to the yards or sites where the vehicles to be fueled are located. Mobile fueling is only conducted using diesel fuel, as mobile fueling of gasoline is prohibited. Diesel fuel is considered as a Class II Combustible Liquid, whereas gasoline is considered as a Flammable Liquid.

Historically mobile fueling has been conducted for off-road vehicles that are operated for extended periods of time in remote areas. This includes construction sites, logging operations, and farms. Mobile fueling of on-road vehicles is also conducted commercially in the State of Washington.

**Pollutant Control Approach:** Proper training of the fueling operator, and the use of spill/drip control and reliable fuel transfer equipment with backup shutoff valving are typically needed.

### **Applicable Operational BMPs:**

Organizations and individuals conducting mobile fueling operations must implement the following BMPs. The operating procedures for the driver/operator should be simple, clear, effective and their implementation verified by the organization that will potentially be liable for environmental and third party damage.

- Ensure that all mobile fueling operations are approved by the local fire department and comply with local and Washington State fire codes.
- In fueling locations that are in close proximity to sensitive aquifers, designated wetlands, wetland buffers, or other waters of the State, approval by local jurisdictions is necessary to ensure compliance with additional local requirements.
- Ensure the compliance with all 49 CFR 178 requirements for DOT 406 cargo tanker. Documentation from a Department of Transportation (DOT) Registered Inspector shall be proof of compliance.
- Ensure the presence and the constant observation/monitoring of the driver/operator at the fuel transfer location at all times during fuel transfer and ensure that the following procedures are implemented at the fuel transfer locations:
  - Locating the point of fueling at least 25 feet from the nearest storm drain or inside an impervious containment with a volumetric holding capacity equal to or greater than 110 percent of the fueling tank volume, or covering the storm drain to ensure no inflow of spilled or leaked fuel. Storm drains that convey the inflow to a spill control separator approved by the local jurisdiction and the

*Note that some local fire departments may have restrictions on mobile fueling practices.*

fire department need not be covered. Potential spill/leak conveyance surfaces must be impervious and in good repair.

- Placement of a drip pan, or an absorbent pad under each fueling location prior to and during all dispensing operations. The pan (must be liquid tight) and the absorbent pad must have a capacity of 5 gallons. Spills retained in the drip pan or the pad need not be reported.
- The handling and operation of fuel transfer hoses and nozzle, drip pan(s), and absorbent pads as needed to prevent spills/leaks of fuel from reaching the ground, storm drains, and receiving waters.
- Not extending the fueling hoses across a traffic lane without fluorescent traffic cones, or equivalent devices, conspicuously placed so that all traffic is blocked from crossing the fuel hose.
- Removing the fill nozzle and cessation of filling when the automatic shut-off valve engages. Do not allow automatic shutoff fueling nozzles to be locked in the open position.
- Not “topping off” the fuel receiving equipment
- Provide the driver/operator of the fueling vehicle with:
  - Adequate flashlights or other mobile lighting to view fill openings with poor accessibility. Consult with local fire department for additional lighting requirements.
  - Two-way communication with his/her home base.
- Train the driver/operator annually in spill prevention and cleanup measures and emergency procedures. Make all employees aware of the significant liability associated with fuel spills.
- The fueling operating procedures should be properly signed and dated by the responsible manager, distributed to the operators, retained in the organization files, and made available in the event an authorized government agency requests a review.
- Ensure that the local fire department (911) and the appropriate regional office of the Department of Ecology are immediately notified in the event of any spill entering the surface or ground waters. Establish a “call down list” to ensure the rapid and proper notification of management and government officials should any significant amount of product be lost off-site. Keep the list in a protected but readily accessible location in the mobile fueling truck. The “call down list” should also pre-identify spill response contractors available in the area to ensure the rapid removal of significant product spillage into the environment.

- Maintain a minimum of the following spill clean-up materials in all fueling vehicles, that are readily available for use:
  - Non-water absorbents capable of absorbing 15 gallons of diesel fuel;
  - A storm drain plug or cover kit;
  - A non-water absorbent containment boom of a minimum 10 feet in length with a 12-gallon absorbent capacity;
  - A non-metallic shovel; and,
  - Two, five-gallon buckets with lids.
- Use automatic shutoff nozzles for dispensing the fuel. Replace automatic shut-off nozzles as recommended by the manufacturer.
- Maintain and replace equipment on fueling vehicles, particularly hoses and nozzles, at established intervals to prevent failures.

**Applicable Structural Source Control BMPs:** Include the following fuel transfer site components:

- Automatic fuel transfer shut-off nozzles; and,
- An adequate lighting system at the filling point.

## **BMPs for Parking and Storage of Vehicles and Equipment**

**Description of Pollutant Sources:** Public and commercial parking lots such as retail store, fleet vehicle (including rent-a-car lots and car dealerships), equipment sale and rental parking lots, and parking lot driveways, can be sources of toxic hydrocarbons and other organic compounds, oils and greases, metals, and suspended solids caused by the parked vehicles.

**Pollutant Control Approach:** If the parking lot is a **high-use site** as defined below, provide appropriate oil removal equipment for the contaminated stormwater runoff.

### **Applicable Operational BMPs:**

- If washing of a parking lot is conducted, discharge the washwater to a sanitary sewer, if allowed by the local sewer authority, or other approved wastewater treatment system, or collect it for off-site disposal.
- Do not hose down the area to a storm drain or to a receiving water. Sweep parking lots, storage areas, and driveways, regularly to collect dirt, waste, and debris.

**Applicable Treatment BMPs:** An oil removal system such as an API or CP oil and water separator, catch basin filter, or equivalent BMP, approved by the local jurisdiction, is applicable for parking lots meeting the threshold vehicle traffic intensity level of a *high-use site*.

### **Vehicle High-Use Sites**

Establishments subject to a vehicle high-use intensity have been determined to be significant sources of oil contamination of stormwater. Examples of potential high use areas include customer parking lots at fast food stores, grocery stores, taverns, restaurants, large shopping malls, discount warehouse stores, quick-lube shops, and banks. If the PGIS for a high-use site exceeds 5,000 square feet in a threshold discharge area, and oil control BMP from the Oil Control Menu is necessary. A high-use site at a commercial or industrial establishment has one of the following characteristics: (Gaus/King County, 1994)

- Is subject to an expected average daily vehicle traffic (ADT) count equal to or greater than 100 vehicles per 1,000 square feet of gross building area: or
- Is subject to storage of a fleet of 25 or more diesel vehicles that are over 10 tons gross weight (trucks, buses, trains, heavy equipment, etc.).

# ***Appendix D***

---

## **Drainage Calculations**

D-1 .....Water Quality

D-2 .....Conveyance

**WWHM2012**  
**PROJECT REPORT**

**D1**

## General Model Information

Project Name: 20210319 - WQ (7\_437ac 80p imp)  
Site Name:  
Site Address:  
City:  
Report Date: 3/19/2021  
Gage: 40 IN EAST  
Data Start: 10/01/1901  
Data End: 09/30/2059  
Timestep: 15 Minute  
Precip Scale: 1.000  
Version Date: 2019/09/13  
Version: 4.2.17

## POC Thresholds

---

Low Flow Threshold for POC1:	50 Percent of the 2 Year
High Flow Threshold for POC1:	50 Year

---

D1

## Landuse Basin Data

### Predeveloped Land Use

Ex about 60%imp

Bypass:	No
GroundWater:	No
Pervious Land Use C, Lawn, Flat	acre 2.935
Pervious Total	2.935
Impervious Land Use PARKING FLAT	acre 4.402
Impervious Total	4.402
Basin Total	7.337

Element Flows To:		
Surface	Interflow	Groundwater

D1



*Mitigated Land Use*

**Basin 1**

Bypass:	No
GroundWater:	No
Pervious Land Use C, Lawn, Flat	acre 1.387
Pervious Total	1.387
Impervious Land Use PARKING FLAT	acre 5.95
Impervious Total	5.95
Basin Total	7.337

Element Flows To:		
Surface	Interflow	Groundwater

**D1**

# Analysis Results

## POC 1

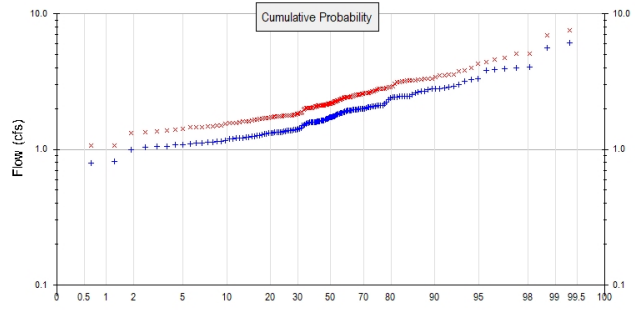
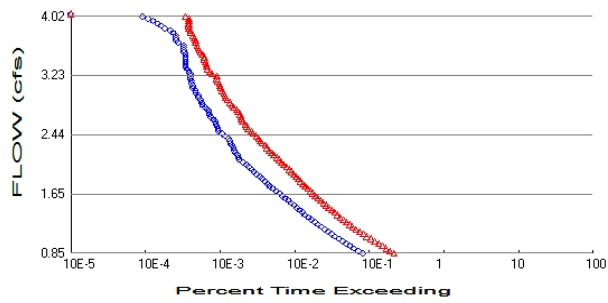

+ Predeveloped    x Mitigated

### Predeveloped Landuse Totals for POC #1

Total Pervious Area: 2.935  
 Total Impervious Area: 4.402

### Mitigated Landuse Totals for POC #1

Total Pervious Area: 1.387  
 Total Impervious Area: 5.95

Flow Frequency Method: Log Pearson Type III 17B

### Flow Frequency Return Periods for Predeveloped. POC #1

Return Period	Flow(cfs)
2 year	1.709898
5 year	2.350912
10 year	2.825503
25 year	3.484782
50 year	4.020894
100 year	4.597023

### Flow Frequency Return Periods for Mitigated. POC #1

Return Period	Flow(cfs)
2 year	2.196103
5 year	2.96862
10 year	3.533137
25 year	4.309126
50 year	4.934306
100 year	5.601221

## Annual Peaks

### Annual Peaks for Predeveloped and Mitigated. POC #1

Year	Predeveloped	Mitigated
1902	1.876	2.529
1903	2.091	2.807
1904	2.877	3.415
1905	1.107	1.447
1906	1.206	1.618
1907	1.845	2.251
1908	1.403	1.799
1909	1.595	2.151
1910	1.767	2.107
1911	1.924	2.414



1912	3.916	4.292
1913	1.242	1.665
1914	6.103	7.505
1915	1.142	1.475
1916	2.000	2.688
1917	0.788	1.064
1918	1.582	2.136
1919	1.079	1.382
1920	1.498	1.852
1921	1.256	1.572
1922	2.096	2.523
1923	1.377	1.716
1924	2.322	3.115
1925	1.038	1.341
1926	1.866	2.520
1927	1.610	2.163
1928	1.231	1.575
1929	2.536	3.180
1930	2.454	3.254
1931	1.234	1.590
1932	1.331	1.710
1933	1.320	1.680
1934	2.430	2.887
1935	1.079	1.456
1936	1.588	2.033
1937	1.966	2.589
1938	1.123	1.479
1939	1.345	1.799
1940	2.453	3.255
1941	2.626	3.533
1942	2.059	2.519
1943	1.887	2.424
1944	2.902	3.581
1945	1.994	2.608
1946	1.715	2.115
1947	1.190	1.573
1948	1.684	2.182
1949	2.470	3.310
1950	1.347	1.820
1951	2.082	2.813
1952	3.165	3.542
1953	2.810	3.228
1954	1.380	1.773
1955	1.208	1.627
1956	1.113	1.504
1957	1.346	1.755
1958	1.898	2.289
1959	1.927	2.300
1960	1.330	1.760
1961	4.020	5.043
1962	1.628	2.120
1963	1.144	1.545
1964	3.844	4.711
1965	1.816	2.209
1966	1.318	1.714
1967	2.068	2.513
1968	1.588	2.045
1969	1.444	1.846

D1

1970	1.731	2.126
1971	1.748	2.106
1972	5.614	6.888
1973	2.803	3.770
1974	2.242	2.849
1975	2.770	3.147
1976	2.690	3.231
1977	0.999	1.316
1978	2.041	2.383
1979	1.971	2.475
1980	2.003	2.419
1981	1.685	2.205
1982	1.360	1.774
1983	1.985	2.467
1984	1.960	2.445
1985	2.392	2.861
1986	1.102	1.394
1987	1.841	2.419
1988	1.132	1.449
1989	1.046	1.407
1990	1.415	1.786
1991	2.161	2.709
1992	1.845	2.493
1993	2.050	2.764
1994	1.656	2.008
1995	1.161	1.506
1996	1.682	2.081
1997	1.412	1.817
1998	1.814	2.232
1999	1.809	2.429
2000	1.609	2.063
2001	1.218	1.646
2002	2.813	3.238
2003	1.369	1.752
2004	1.994	2.611
2005	3.872	5.083
2006	1.725	2.314
2007	2.093	2.665
2008	1.641	2.155
2009	1.199	1.618
2010	1.623	2.118
2011	1.597	2.159
2012	1.616	2.084
2013	1.630	2.017
2014	1.389	1.877
2015	2.851	3.339
2016	1.501	2.027
2017	2.421	3.174
2018	1.737	2.032
2019	2.614	3.039
2020	1.950	2.401
2021	1.578	1.987
2022	2.474	3.239
2023	2.983	4.005
2024	3.983	4.569
2025	1.550	2.095
2026	1.764	2.371
2027	1.930	2.585

D1

2028	0.740	0.999
2029	1.358	1.709
2030	2.664	3.529
2031	0.812	1.062
2032	1.296	1.744
2033	1.631	2.204
2034	1.238	1.673
2035	1.897	2.274
2036	1.286	1.732
2037	1.717	2.320
2038	1.952	2.346
2039	3.270	4.405
2040	1.378	1.774
2041	1.751	2.253
2042	2.012	2.567
2043	2.094	2.818
2044	1.525	1.971
2045	1.262	1.610
2046	1.399	1.787
2047	1.580	2.135
2048	1.302	1.755
2049	1.934	2.604
2050	1.600	2.022
2051	2.434	2.925
2052	1.560	2.108
2053	1.328	1.783
2054	3.315	3.839
2055	1.573	2.045
2056	2.098	2.813
2057	1.053	1.367
2058	1.944	2.627
2059	2.455	3.315

### Ranked Annual Peaks

Ranked Annual Peaks for Predeveloped and Mitigated. POC #1

Rank	Predeveloped	Mitigated
1	6.1029	7.5051
2	5.6142	6.8879
3	4.0195	5.0829
4	3.9825	5.0431
5	3.9159	4.7113
6	3.8721	4.5689
7	3.8439	4.4046
8	3.3155	4.2917
9	3.2697	4.0046
10	3.1649	3.8393
11	2.9834	3.7698
12	2.9023	3.5814
13	2.8772	3.5418
14	2.8506	3.5334
15	2.8127	3.5286
16	2.8099	3.4154
17	2.8029	3.3386
18	2.7701	3.3147
19	2.6896	3.3097
20	2.6644	3.2553
21	2.6260	3.2539
22	2.6135	3.2390



23	2.5359	3.2376
24	2.4738	3.2310
25	2.4697	3.2282
26	2.4554	3.1796
27	2.4543	3.1738
28	2.4528	3.1472
29	2.4336	3.1148
30	2.4305	3.0385
31	2.4206	2.9254
32	2.3917	2.8867
33	2.3225	2.8614
34	2.2419	2.8494
35	2.1611	2.8176
36	2.0976	2.8132
37	2.0964	2.8129
38	2.0943	2.8068
39	2.0932	2.7636
40	2.0911	2.7090
41	2.0821	2.6882
42	2.0676	2.6655
43	2.0592	2.6268
44	2.0505	2.6115
45	2.0408	2.6083
46	2.0124	2.6037
47	2.0028	2.5894
48	2.0004	2.5851
49	1.9944	2.5669
50	1.9937	2.5291
51	1.9846	2.5228
52	1.9713	2.5205
53	1.9663	2.5192
54	1.9602	2.5133
55	1.9519	2.4929
56	1.9497	2.4749
57	1.9442	2.4672
58	1.9336	2.4446
59	1.9304	2.4288
60	1.9265	2.4235
61	1.9236	2.4194
62	1.8977	2.4190
63	1.8968	2.4136
64	1.8868	2.4010
65	1.8764	2.3829
66	1.8664	2.3710
67	1.8452	2.3458
68	1.8445	2.3196
69	1.8415	2.3145
70	1.8159	2.3001
71	1.8144	2.2889
72	1.8094	2.2744
73	1.7670	2.2527
74	1.7642	2.2508
75	1.7507	2.2316
76	1.7479	2.2086
77	1.7369	2.2050
78	1.7310	2.2036
79	1.7255	2.1816
80	1.7170	2.1628

D1

81	1.7151	2.1587
82	1.6848	2.1553
83	1.6835	2.1507
84	1.6818	2.1356
85	1.6559	2.1352
86	1.6409	2.1261
87	1.6306	2.1201
88	1.6302	2.1179
89	1.6282	2.1154
90	1.6235	2.1083
91	1.6155	2.1070
92	1.6104	2.1065
93	1.6094	2.0952
94	1.5998	2.0839
95	1.5974	2.0813
96	1.5945	2.0634
97	1.5883	2.0454
98	1.5879	2.0451
99	1.5824	2.0326
100	1.5802	2.0321
101	1.5779	2.0275
102	1.5732	2.0219
103	1.5602	2.0167
104	1.5505	2.0077
105	1.5250	1.9873
106	1.5007	1.9710
107	1.4982	1.8767
108	1.4438	1.8520
109	1.4147	1.8457
110	1.4120	1.8198
111	1.4029	1.8174
112	1.3990	1.7994
113	1.3889	1.7990
114	1.3798	1.7873
115	1.3782	1.7863
116	1.3773	1.7830
117	1.3686	1.7736
118	1.3604	1.7736
119	1.3580	1.7734
120	1.3469	1.7595
121	1.3460	1.7554
122	1.3448	1.7553
123	1.3311	1.7521
124	1.3300	1.7438
125	1.3276	1.7323
126	1.3197	1.7159
127	1.3181	1.7142
128	1.3017	1.7095
129	1.2956	1.7094
130	1.2864	1.6802
131	1.2617	1.6730
132	1.2563	1.6653
133	1.2422	1.6464
134	1.2383	1.6271
135	1.2339	1.6182
136	1.2309	1.6179
137	1.2183	1.6100
138	1.2083	1.5901

D1

139	1.2059	1.5746
140	1.1986	1.5729
141	1.1897	1.5718
142	1.1610	1.5445
143	1.1441	1.5059
144	1.1419	1.5037
145	1.1324	1.4793
146	1.1232	1.4754
147	1.1128	1.4561
148	1.1073	1.4486
149	1.1024	1.4474
150	1.0794	1.4069
151	1.0789	1.3939
152	1.0529	1.3823
153	1.0463	1.3669
154	1.0383	1.3408
155	0.9988	1.3161
156	0.8119	1.0640
157	0.7878	1.0619
158	0.7403	0.9987

D1



## Duration Flows

Flow(cfs)	Predev	Mit	Percentage	Pass/Fail
0.8549	4572	11872	259	Fail
0.8869	3946	10476	265	Fail
0.9189	3475	9324	268	Fail
0.9509	3061	8260	269	Fail
0.9829	2705	7352	271	Fail
1.0148	2408	6532	271	Fail
1.0468	2154	5778	268	Fail
1.0788	1926	5139	266	Fail
1.1108	1711	4585	267	Fail
1.1428	1540	4109	266	Fail
1.1747	1397	3665	262	Fail
1.2067	1265	3317	262	Fail
1.2387	1128	3019	267	Fail
1.2707	1018	2718	266	Fail
1.3027	919	2481	269	Fail
1.3346	844	2261	267	Fail
1.3666	749	2063	275	Fail
1.3986	701	1902	271	Fail
1.4306	645	1734	268	Fail
1.4626	593	1582	266	Fail
1.4945	547	1451	265	Fail
1.5265	497	1339	269	Fail
1.5585	455	1230	270	Fail
1.5905	413	1125	272	Fail
1.6225	376	1048	278	Fail
1.6544	349	966	276	Fail
1.6864	312	902	289	Fail
1.7184	282	826	292	Fail
1.7504	253	765	302	Fail
1.7823	239	712	297	Fail
1.8143	221	661	299	Fail
1.8463	203	611	300	Fail
1.8783	187	571	305	Fail
1.9103	172	537	312	Fail
1.9422	157	498	317	Fail
1.9742	147	465	316	Fail
2.0062	133	430	323	Fail
2.0382	126	392	311	Fail
2.0702	112	366	326	Fail
2.1021	100	341	341	Fail
2.1341	97	317	326	Fail
2.1661	95	291	306	Fail
2.1981	89	272	305	Fail
2.2301	85	251	295	Fail
2.2620	84	235	279	Fail
2.2940	80	223	278	Fail
2.3260	76	201	264	Fail
2.3580	74	190	256	Fail
2.3900	71	181	254	Fail
2.4219	64	169	264	Fail
2.4539	58	153	263	Fail
2.4859	53	146	275	Fail
2.5179	52	132	253	Fail
2.5498	50	126	252	Fail

D1

2.5818	48	120	250	Fail
2.6138	47	109	231	Fail
2.6458	45	107	237	Fail
2.6778	41	105	256	Fail
2.7097	40	103	257	Fail
2.7417	39	96	246	Fail
2.7737	37	92	248	Fail
2.8057	35	84	240	Fail
2.8377	32	79	246	Fail
2.8696	31	75	241	Fail
2.9016	30	69	230	Fail
2.9336	28	65	232	Fail
2.9656	28	64	228	Fail
2.9976	26	62	238	Fail
3.0295	26	59	226	Fail
3.0615	24	56	233	Fail
3.0935	24	55	229	Fail
3.1255	23	54	234	Fail
3.1575	23	52	226	Fail
3.1894	22	50	227	Fail
3.2214	22	50	227	Fail
3.2534	22	43	195	Fail
3.2854	21	40	190	Fail
3.3174	20	37	185	Fail
3.3493	19	36	189	Fail
3.3813	19	36	189	Fail
3.4133	19	35	184	Fail
3.4453	19	34	178	Fail
3.4772	19	34	178	Fail
3.5092	19	32	168	Fail
3.5412	18	30	166	Fail
3.5732	18	29	161	Fail
3.6052	18	28	155	Fail
3.6371	18	27	150	Fail
3.6691	15	26	173	Fail
3.7011	14	26	185	Fail
3.7331	14	25	178	Fail
3.7651	14	24	171	Fail
3.7970	13	22	169	Fail
3.8290	12	22	183	Fail
3.8610	10	21	209	Fail
3.8930	9	21	233	Fail
3.9250	8	21	262	Fail
3.9569	7	21	300	Fail
3.9889	6	21	350	Fail
4.0209	5	19	380	Fail

The development has an increase in flow durations from 1/2 Predeveloped 2 year flow to the 2 year flow or more than a 10% increase from the 2 year to the 50 year flow.

The development has an increase in flow durations for more than 50% of the flows for the range of the duration analysis.



## Water Quality

Water Quality BMP Flow and Volume for POC #1

On-line facility volume: 0.6852 acre-feet

On-line facility target flow: 0.8956 cfs.

Adjusted for 15 min: 0.8956 cfs.

Off-line facility target flow: 0.5178 cfs.

Adjusted for 15 min: 0.5178 cfs.

D1

# LID Report

LID Technique	Used for Treatment ?	Total Volume Needs Treatment (ac-ft)	Volume Through Facility (ac-ft)	Infiltration Volume (ac-ft)	Cumulative Volume Infiltration Credit	Percent Volume Infiltrated	Water Quality	Percent Water Quality Treated	Comment
Total Volume Infiltrated		0.00	0.00	0.00		0.00	0.00	0%	No Treat. Credit
Compliance with LID Standard 8% of 2-yr to 50% of 2-yr									Duration Analysis Result = Failed

D1

## *Model Default Modifications*

Total of 0 changes have been made.

### *PERLND Changes*

No PERLND changes have been made.

### *IMPLND Changes*

No IMPLND changes have been made.

**D1**

*Appendix*  
*Predeveloped Schematic*



Ex about  
60%imp  
7.34ac

**D1**

Mitigated Schematic

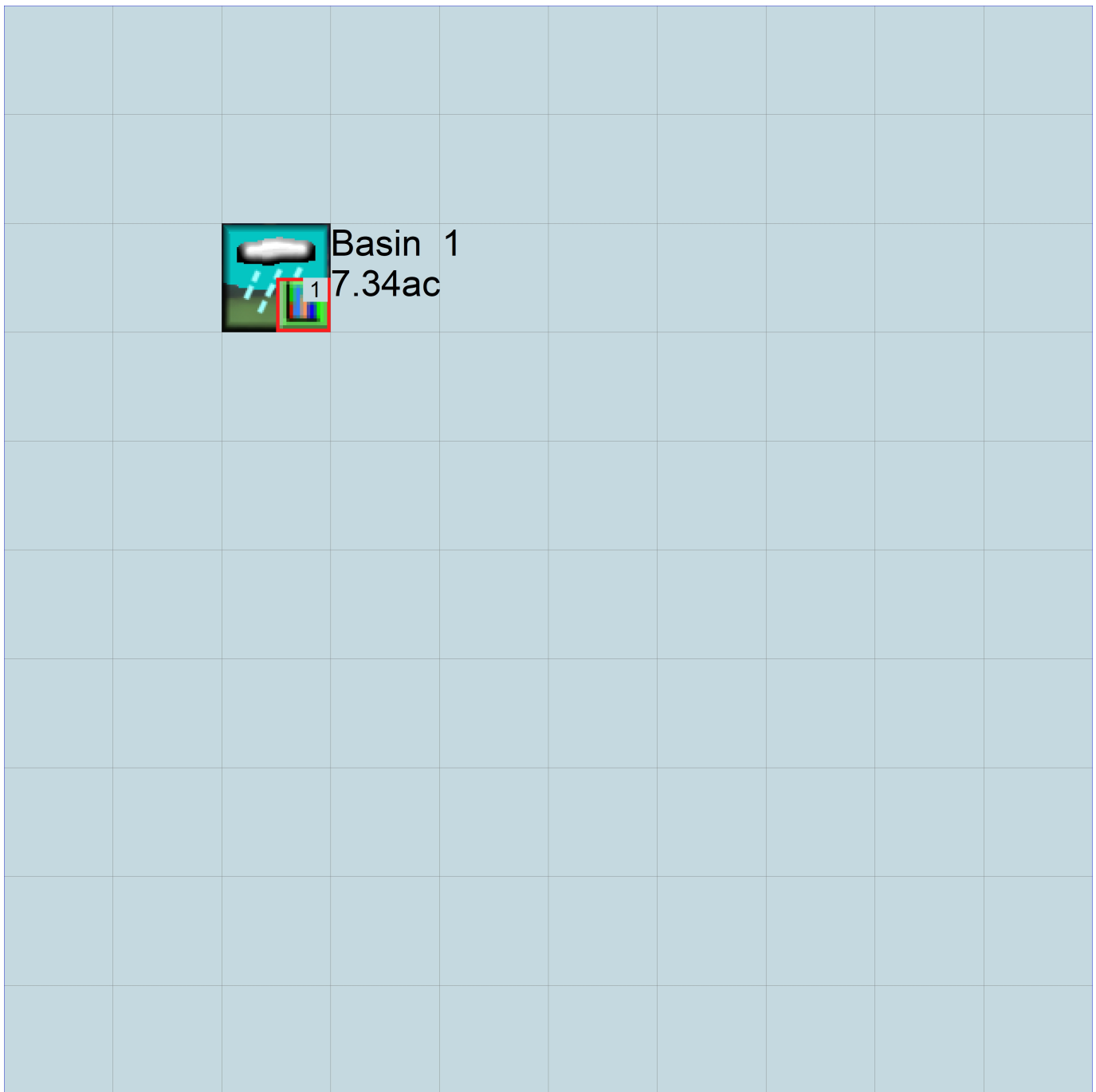

D1

## *Disclaimer*

### *Legal Notice*

This program and accompanying documentation are provided 'as-is' without warranty of any kind. The entire risk regarding the performance and results of this program is assumed by End User. Clear Creek Solutions Inc. and the governmental licensee or sublicensees disclaim all warranties, either expressed or implied, including but not limited to implied warranties of program and accompanying documentation. In no event shall Clear Creek Solutions Inc. be liable for any damages whatsoever (including without limitation to damages for loss of business profits, loss of business information, business interruption, and the like) arising out of the use of, or inability to use this program even if Clear Creek Solutions Inc. or their authorized representatives have been advised of the possibility of such damages. Software Copyright © by : Clear Creek Solutions, Inc. 2005-2021; All Rights Reserved.

Clear Creek Solutions, Inc.  
6200 Capitol Blvd. Ste F  
Olympia, WA. 98501  
Toll Free 1(866)943-0304  
Local (360)943-0304

[www.clearcreeksolutions.com](http://www.clearcreeksolutions.com)

D1



## Project Description

File Name ..... 20210616 - LRR Conveyance Calculation Model Upd.SPF  
 Description ..... Q:\2016\2160102\10\_CIV\CAD\EXHIBITS\Storm Report\_2160102-Conveyance Basins.dwg

## Project Options

Flow Units ..... CFS  
 Elevation Type ..... Elevation  
 Hydrology Method ..... Santa Barbara UH  
 Time of Concentration (TOC) Method ..... SCS TR-55  
 Link Routing Method ..... Hydrodynamic  
 Enable Overflow Ponding at Nodes ..... YES  
 Skip Steady State Analysis Time Periods ..... YES

## Analysis Options

Start Analysis On ..... Jun 16, 2021 00:00:00  
 End Analysis On ..... Jun 17, 2021 00:00:00  
 Start Reporting On ..... Jun 16, 2021 00:00:00  
 Antecedent Dry Days ..... 0 days  
 Runoff (Dry Weather) Time Step ..... 0 01:00:00 days hh:mm:ss  
 Runoff (Wet Weather) Time Step ..... 0 00:05:00 days hh:mm:ss  
 Reporting Time Step ..... 0 00:05:00 days hh:mm:ss  
 Routing Time Step ..... 30 seconds

## Number of Elements

	Qty
Rain Gages .....	1
Subbasins.....	27
Nodes.....	23
<i>Junctions</i> .....	22
<i>Outfalls</i> .....	1
<i>Flow Diversions</i> .....	0
<i>Inlets</i> .....	0
<i>Storage Nodes</i> .....	0
Links.....	22
<i>Channels</i> .....	0
<i>Pipes</i> .....	22
<i>Pumps</i> .....	0
<i>Orifices</i> .....	0
<i>Weirs</i> .....	0
<i>Outlets</i> .....	0
Pollutants .....	0
Land Uses .....	0

## Rainfall Details

SN	Rain Gage ID	Data Source	Data Source ID	Rainfall Type	Rain Units	State	County	Return Period (years)	Rainfall Depth (inches)	Rainfall Distribution
1	Rain Gage-02	Time Series	TS-02	Cumulative	inches	Washington	Pierce	25	3.45	SCS Type IA 24-hr



## Subbasin Summary

SN Subbasin ID	Area (ac)	Impervious Area (%)	Impervious Area Curve Number	Pervious Area Curve Number	Total Rainfall (in)	Total Runoff (in)	Total Runoff Volume (ac-in)	Peak Runoff (cfs)	Time of Concentration (days hh:mm:ss)
1 {Site 1}.EX BLDG AND PAVE N	0.16	100.00	98.00	76.00	3.44	3.21	0.52	0.13	0 00:05:00
2 {Site 1}.EX BLDG AND PAVEMENT NW	0.32	98.00	98.00	76.00	3.44	3.17	1.01	0.25	0 00:05:00
3 {Site 1}.EX BLDG N	0.23	100.00	98.00	76.00	3.44	3.21	0.73	0.18	0 00:05:00
4 {Site 1}.EX BLDG NW	0.05	100.00	98.00	76.00	3.44	3.21	0.17	0.04	0 00:05:00
5 {Site 1}.EX BLDG SE	0.06	100.00	98.00	76.00	3.44	3.21	0.19	0.05	0 00:05:00
6 {Site 1}.EX PAVE N	0.14	100.00	98.00	76.00	3.44	3.21	0.44	0.11	0 00:05:00
7 {Site 1}.FR1	0.04	92.00	98.00	76.00	3.44	3.06	0.12	0.03	0 00:05:00
8 {Site 1}.FR2	0.26	97.00	98.00	76.00	3.44	3.15	0.83	0.21	0 00:05:00
9 {Site 1}.L1	0.34	97.00	98.00	76.00	3.44	3.15	1.06	0.27	0 00:05:00
10 {Site 1}.L2	0.34	96.00	98.00	76.00	3.44	3.13	1.05	0.26	0 00:05:00
11 {Site 1}.L3	0.34	96.00	98.00	76.00	3.44	3.13	1.06	0.27	0 00:05:00
12 {Site 1}.L4	0.34	96.00	98.00	76.00	3.44	3.13	1.07	0.27	0 00:05:00
13 {Site 1}.L5	0.45	96.00	98.00	76.00	3.44	3.13	1.42	0.36	0 00:05:00
14 {Site 1}.L6	0.21	95.00	98.00	76.00	3.44	3.11	0.65	0.16	0 00:05:00
15 {Site 1}.L7	0.26	95.00	98.00	76.00	3.44	3.11	0.82	0.21	0 00:05:00
16 {Site 1}.M1	0.34	100.00	98.00	76.00	3.44	3.21	1.10	0.28	0 00:05:00
17 {Site 1}.M3	0.34	100.00	98.00	76.00	3.44	3.21	1.10	0.28	0 00:05:00
18 {Site 1}.M4	0.34	98.00	98.00	76.00	3.44	3.17	1.07	0.27	0 00:05:00
19 {Site 1}.M5	0.17	93.00	98.00	76.00	3.44	3.08	0.52	0.13	0 00:05:00
20 {Site 1}.M6	0.26	95.00	98.00	76.00	3.44	3.11	0.81	0.20	0 00:05:00
21 {Site 1}.M7	0.43	97.00	98.00	76.00	3.44	3.15	1.35	0.34	0 00:05:00
22 {Site 1}.MR1	0.19	98.00	98.00	76.00	3.44	3.17	0.61	0.15	0 00:05:00
23 {Site 1}.MR2	0.28	98.00	98.00	76.00	3.44	3.17	0.88	0.22	0 00:05:00
24 {Site 1}.MR3	0.27	98.00	98.00	76.00	3.44	3.17	0.86	0.22	0 00:05:00
25 {Site 1}.MR4	0.45	98.00	98.00	76.00	3.44	3.17	1.42	0.36	0 00:05:00
26 {Site 1}.MR5	0.05	98.00	98.00	76.00	3.44	3.17	0.16	0.04	0 00:05:00
27 M2	0.28	100.00	98.00	76.00	3.44	3.21	0.90	0.23	0 00:05:00

## Node Summary

SN Element ID	Element Type	Invert Elevation	Ground/Rim (Max) Elevation	Initial Water Elevation	Surcharge Elevation	Ponded Area	Peak Inflow	Max HGL Elevation Attained	Max Surcharge Depth Attained	Min Freeboard Attained	Time of Peak Flooding Occurrence	Total Flooded Volume	Total Time Flooded
		(ft)	(ft)	(ft)	(ft)	(ft²)	(cfs)	(ft)	(ft)	(ft)	(days hh:mm)	(ac-in)	(min)
1 CB 1	Junction	25.17	38.25	25.17	38.25	0.00	5.47	26.52	0.00	11.73	0 00:00	0.00	0.00
2 CB 11	Junction	32.36	36.89	32.36	36.89	0.00	1.23	33.04	0.00	3.86	0 00:00	0.00	0.00
3 CB 12	Junction	32.68	37.33	32.68	37.33	0.00	0.96	33.26	0.00	4.07	0 00:00	0.00	0.00
4 CB 13	Junction	33.00	37.27	33.00	37.27	0.00	0.65	33.39	0.00	3.88	0 00:00	0.00	0.00
5 CB 14	Junction	33.39	36.44	33.39	36.44	0.00	0.34	33.66	0.00	2.78	0 00:00	0.00	0.00
6 CB 15	Junction	31.83	35.86	31.83	35.86	0.00	2.08	32.77	0.00	3.09	0 00:00	0.00	0.00
7 CB 16	Junction	33.33	36.38	33.33	36.38	0.00	0.27	33.60	0.00	2.78	0 00:00	0.00	0.00
8 CB 17	Junction	32.15	35.72	32.15	35.72	0.00	1.55	32.93	0.00	2.79	0 00:00	0.00	0.00
9 CB 18	Junction	32.47	35.72	32.47	35.72	0.00	1.29	33.17	0.00	2.55	0 00:00	0.00	0.00
10 CB 19	Junction	32.79	35.88	32.79	35.88	0.00	1.09	33.39	0.00	2.49	0 00:00	0.00	0.00
11 CB 2	Junction	28.58	38.40	28.58	38.40	0.00	5.44	29.94	0.00	8.46	0 00:00	0.00	0.00
12 CB 20	Junction	33.44	36.48	33.44	36.48	0.00	0.21	33.69	0.00	2.80	0 00:00	0.00	0.00
13 CB 21	Junction	34.00	37.05	34.00	37.05	0.00	0.46	34.32	0.00	2.73	0 00:00	0.00	0.00
14 CB 3	Junction	29.17	37.23	29.17	37.23	0.00	5.19	30.49	0.00	6.74	0 00:00	0.00	0.00
15 CB 4	Junction	34.20	37.25	34.20	37.25	0.00	0.15	34.40	0.00	2.85	0 00:00	0.00	0.00
16 CB 5	Junction	34.33	37.38	34.33	37.38	0.00	0.74	34.94	0.00	2.44	0 00:00	0.00	0.00
17 CB 6	Junction	34.76	37.81	34.76	37.81	0.00	0.53	35.26	0.00	2.55	0 00:00	0.00	0.00
18 CB 7	Junction	36.78	39.88	36.78	39.88	0.00	0.04	36.92	0.00	2.96	0 00:00	0.00	0.00
19 CB 8	Junction	30.20	35.84	30.20	35.84	0.00	4.08	31.34	0.00	4.50	0 00:00	0.00	0.00
20 CB 9	Junction	33.12	36.17	33.12	36.17	0.00	0.28	33.40	0.00	2.77	0 00:00	0.00	0.00
21 CB_10	Junction	32.04	36.20	32.04	36.20	0.00	1.51	32.80	0.00	3.40	0 00:00	0.00	0.00
22 CONNECT TO EX CB2	Junction	35.21	35.73	35.21	35.73	0.00	0.25	35.48	0.00	0.40	0 00:00	0.00	0.00
23 Out-1P - (25)	Outfall	24.40					5.48	24.95					



## Link Summary

SN	Element ID	Element Type	From (Inlet) Node	To (Outlet) Node	Length (ft)	Inlet Invert Elevation (ft)	Outlet Invert Elevation (ft)	Average Slope (%)	Diameter or Height (in)	Manning's Roughness	Peak Flow (cfs)	Design Flow Capacity (cfs)	Peak Flow/Design Flow Ratio	Peak Flow Velocity (ft/sec)	Peak Flow Depth (ft)	Peak Flow Depth/Total Depth Ratio	Total Time Reported (min)	Reported Condition
1	.5	Pipe	CB 11	CB_10	64.00	32.36	32.04	0.5000	12.000	0.0120	1.23	2.73	0.45	2.14	0.72	0.72	0.00	Calculated
2	P - (10)	Pipe	CB 2	CB 1	71.30	28.58	28.22	0.5000	18.000	0.0120	5.44	8.05	0.68	3.82	1.13	0.75	0.00	Calculated
3	P - (11)	Pipe	CB 16	CB 15	64.00	33.33	31.33	3.1300	8.000	0.0120	0.27	2.00	0.13	1.01	0.47	0.70	0.00	Calculated
4	P - (12)	Pipe	CB 17	CB 15	64.02	32.15	31.83	0.5000	12.000	0.0120	1.55	2.73	0.57	2.15	0.86	0.86	0.00	Calculated
5	P - (13)	Pipe	CB 9	CB 8	64.00	33.12	30.53	4.0500	8.000	0.0120	0.28	2.63	0.11	2.16	0.47	0.71	0.00	Calculated
6	P - (14)	Pipe	CB 8	CB_10	64.00	30.20	32.04	-2.8700	12.000	0.0120	1.51	6.54	0.23	2.06	0.88	0.88	0.00	Calculated
7	P - (15)	Pipe	CB 14	CB 13	77.23	33.39	33.00	0.5000	12.000	0.0120	0.34	2.73	0.12	1.54	0.33	0.33	0.00	Calculated
8	P - (16)	Pipe	CB 13	CB 12	64.68	33.00	32.68	0.5000	12.000	0.0120	0.65	2.71	0.24	1.86	0.48	0.48	0.00	Calculated
9	P - (17)	Pipe	CB 12	CB 11	64.00	32.68	32.36	0.5000	12.000	0.0120	0.96	2.73	0.35	2.05	0.63	0.63	0.00	Calculated
10	P - (19)	Pipe	CB 7	CB 6	55.02	36.78	34.76	3.6700	8.000	0.0120	0.04	2.51	0.02	0.38	0.32	0.48	0.00	Calculated
11	P - (20)	Pipe	CB 6	CB 5	66.44	34.76	33.79	1.4600	8.000	0.0120	0.53	1.58	0.33	1.83	0.55	0.83	0.00	Calculated
12	P - (21)	Pipe	CONNECT TO EX CB2	CB 21	64.31	35.21	34.33	1.3600	8.000	0.0120	0.25	1.53	0.17	2.44	0.23	0.34	0.00	Calculated
13	P - (25)	Pipe	CB 1	Out-1P - (25)	26.74	25.17	24.40	2.8800	18.000	0.0120	5.48	19.31	0.28	4.66	0.95	0.63	0.00	Calculated
14	P - (26)	Pipe	CB 4	CB 3	70.08	34.20	30.00	5.9900	8.000	0.0120	0.15	3.21	0.05	2.41	0.34	0.51	0.00	Calculated
15	P - (27)	Pipe	CB 21	CB 19	97.22	34.00	32.79	1.2400	12.000	0.0120	0.46	4.30	0.11	1.51	0.46	0.46	0.00	Calculated
16	P - (3)	Pipe	CB 20	CB 19	108.58	33.44	32.79	0.6000	12.000	0.0120	0.27	2.99	0.09	0.88	0.42	0.42	0.00	Calculated
17	P - (4)	Pipe	CB 19	CB 18	63.74	32.79	32.47	0.5000	12.000	0.0120	1.02	2.72	0.37	2.12	0.65	0.65	0.00	Calculated
18	P - (5)	Pipe	CB 18	CB 17	64.25	32.47	32.15	0.5000	12.000	0.0120	1.28	2.73	0.47	2.12	0.74	0.74	0.00	Calculated
19	P - (6)	Pipe	CB 15	CB 8	225.00	31.83	30.20	0.7200	12.000	0.0120	2.07	3.28	0.63	2.66	0.97	0.97	0.00	Calculated
20	P - (7)	Pipe	CB 8	CB 3	206.99	30.20	29.17	0.5000	18.000	0.0120	4.08	8.03	0.51	2.63	1.23	0.82	0.00	Calculated
21	P - (8)	Pipe	CB 5	CB 3	63.11	33.79	30.00	6.0100	8.000	0.0120	0.74	3.43	0.22	3.33	0.55	0.82	0.00	Calculated
22	P - (9)	Pipe	CB 3	CB 2	118.56	29.17	28.58	0.5000	18.000	0.0120	5.19	8.03	0.65	3.12	1.34	0.89	0.00	Calculated

D2

# Subbasin Hydrology

## Subbasin : {Site 1}.EX BLDG AND PAVE N

### Input Data

Area (ac) ..... 0.16  
 Impervious Area (%) ..... 100.00  
 Impervious Area Curve Number ..... 98.00  
 Pervious Area Curve Number ..... 76.00  
 Rain Gage ID ..... Rain Gage-02

### Composite Curve Number

Soil/Surface Description	Area (acres)	Soil Group	Curve Number
Composite Area & Weighted CN	0.16		98

### Time of Concentration

TOC Method : SCS TR-55

Sheet Flow Equation :

$$T_c = (0.007 * ((n * L_f)^{0.8})) / ((P^{0.5}) * (S_f^{0.4}))$$

Where :

Tc = Time of Concentration (hr)  
 n = Manning's roughness  
 Lf = Flow Length (ft)  
 P = 2 yr, 24 hr Rainfall (inches)  
 Sf = Slope (ft/ft)

Shallow Concentrated Flow Equation :

V = 16.1345 \* (Sf^0.5) (unpaved surface)  
 V = 20.3282 \* (Sf^0.5) (paved surface)  
 V = 15.0 \* (Sf^0.5) (grassed waterway surface)  
 V = 10.0 \* (Sf^0.5) (nearly bare & untilled surface)  
 V = 9.0 \* (Sf^0.5) (cultivated straight rows surface)  
 V = 7.0 \* (Sf^0.5) (short grass pasture surface)  
 V = 5.0 \* (Sf^0.5) (woodland surface)  
 V = 2.5 \* (Sf^0.5) (forest w/heavy litter surface)  
 Tc = (Lf / V) / (3600 sec/hr)

Where:

Tc = Time of Concentration (hr)  
 Lf = Flow Length (ft)  
 V = Velocity (ft/sec)  
 Sf = Slope (ft/ft)

Channel Flow Equation :

V = (1.49 \* (R^(2/3)) \* (Sf^0.5)) / n  
 R = Aq / Wp  
 Tc = (Lf / V) / (3600 sec/hr)

Where :

Tc = Time of Concentration (hr)  
 Lf = Flow Length (ft)  
 R = Hydraulic Radius (ft)  
 Aq = Flow Area (ft<sup>2</sup>)  
 Wp = Wetted Perimeter (ft)  
 V = Velocity (ft/sec)  
 Sf = Slope (ft/ft)  
 n = Manning's roughness

User-Defined TOC override (minutes): 5.00

### Subbasin Runoff Results

Total Rainfall (in) ..... 3.44  
 Total Runoff (in) ..... 3.21  
 Peak Runoff (cfs) ..... 0.13  
 Weighted Curve Number ..... 98.00  
 Time of Concentration (days hh:mm:ss) ..... 0 00:05:00



## Junction Input

SN Element ID	Invert Elevation (ft)	Ground/Rim (Max) Elevation (ft)	Ground/Rim (Max) Offset (ft)	Initial Water Elevation (ft)	Initial Water Depth (ft)	Surcharge Elevation (ft)	Surcharge Depth (ft)	Ponded Area (ft²)	Minimum Pipe Cover (in)
1 CB 1	25.17	38.25	13.08	25.17	0.00	38.25	0.00	0.00	102.35
2 CB 11	32.36	36.89	4.53	32.36	0.00	36.89	0.00	0.00	42.40
3 CB 12	32.68	37.33	4.65	32.68	0.00	37.33	0.00	0.00	43.78
4 CB 13	33.00	37.27	4.27	33.00	0.00	37.27	0.00	0.00	39.15
5 CB 14	33.39	36.44	3.05	33.39	0.00	36.44	0.00	0.00	24.60
6 CB 15	31.83	35.86	4.03	31.83	0.00	35.86	0.00	0.00	36.36
7 CB 16	33.33	36.38	3.05	33.33	0.00	36.38	0.00	0.00	28.64
8 CB 17	32.15	35.72	3.57	32.15	0.00	35.72	0.00	0.00	30.85
9 CB 18	32.47	35.72	3.25	32.47	0.00	35.72	0.00	0.00	26.99
10 CB 19	32.79	35.88	3.09	32.79	0.00	35.88	0.00	0.00	25.08
11 CB 2	28.58	38.40	9.82	28.58	0.00	38.40	0.00	0.00	99.84
12 CB 20	33.44	36.48	3.04	33.44	0.00	36.48	0.00	0.00	24.53
13 CB 21	34.00	37.05	3.05	34.00	0.00	37.05	0.00	0.00	24.55
14 CB 3	29.17	37.23	8.06	29.17	0.00	37.23	0.00	0.00	78.75
15 CB 4	34.20	37.25	3.05	34.20	0.00	37.25	0.00	0.00	28.60
16 CB 5	34.33	37.38	3.05	34.33	0.00	37.38	0.00	0.00	35.05
17 CB 6	34.76	37.81	3.05	34.76	0.00	37.81	0.00	0.00	28.64
18 CB 7	36.78	39.88	3.10	36.78	0.00	39.88	0.00	0.00	29.16
19 CB 8	30.20	35.84	5.64	30.20	0.00	35.84	0.00	0.00	49.68
20 CB 9	33.12	36.17	3.05	33.12	0.00	36.17	0.00	0.00	28.62
21 CB_10	32.04	36.20	4.16	32.04	0.00	36.20	0.00	0.00	37.92
22 CONNECT TO EX CB2	35.21	35.73	0.52	35.21	0.00	35.73	0.00	0.00	0.00

## Junction Results

SN Element ID	Peak Inflow	Peak Lateral Inflow	Max HGL Elevation Attained	Max HGL Depth Attained	Max Surcharge Depth Attained	Min Freeboard Attained	Average HGL Elevation Attained	Average HGL Depth Attained	Time of Max HGL Occurrence	Time of Peak Flooding Occurrence	Total Flooded Volume	Total Time Flooded
	(cfs)	(cfs)	(ft)	(ft)	(ft)	(ft)	(ft)	(ft)	(days hh:mm)	(days hh:mm)	(ac-in)	(min)
1 CB 1	5.47	0.03	26.52	1.35	0.00	11.73	25.68	0.51	0 07:55	0 00:00	0.00	0.00
2 CB 11	1.23	0.27	33.04	0.68	0.00	3.86	32.64	0.28	0 07:55	0 00:00	0.00	0.00
3 CB 12	0.96	0.31	33.26	0.58	0.00	4.07	32.93	0.25	0 07:55	0 00:00	0.00	0.00
4 CB 13	0.65	0.31	33.39	0.39	0.00	3.88	33.22	0.22	0 07:54	0 00:00	0.00	0.00
5 CB 14	0.34	0.34	33.66	0.27	0.00	2.78	33.55	0.16	0 07:54	0 00:00	0.00	0.00
6 CB 15	2.08	0.26	32.77	0.94	0.00	3.09	32.18	0.35	0 07:54	0 00:00	0.00	0.00
7 CB 16	0.27	0.27	33.60	0.27	0.00	2.78	33.48	0.15	0 07:54	0 00:00	0.00	0.00
8 CB 17	1.55	0.27	32.93	0.78	0.00	2.79	32.45	0.30	0 07:56	0 00:00	0.00	0.00
9 CB 18	1.29	0.27	33.17	0.70	0.00	2.55	32.75	0.28	0 07:56	0 00:00	0.00	0.00
10 CB 19	1.09	0.36	33.39	0.60	0.00	2.49	33.05	0.26	0 07:55	0 00:00	0.00	0.00
11 CB 2	5.44	0.26	29.94	1.36	0.00	8.46	29.09	0.51	0 07:57	0 00:00	0.00	0.00
12 CB 20	0.21	0.21	33.69	0.25	0.00	2.80	33.57	0.13	0 07:54	0 00:00	0.00	0.00
13 CB 21	0.46	0.21	34.32	0.32	0.00	2.73	34.18	0.18	0 07:55	0 00:00	0.00	0.00
14 CB 3	5.19	0.22	30.49	1.32	0.00	6.74	29.67	0.50	0 07:57	0 00:00	0.00	0.00
15 CB 4	0.15	0.15	34.40	0.20	0.00	2.85	34.31	0.11	0 07:54	0 00:00	0.00	0.00
16 CB 5	0.74	0.22	34.94	0.61	0.00	2.44	34.55	0.22	0 07:55	0 00:00	0.00	0.00
17 CB 6	0.53	0.49	35.26	0.50	0.00	2.55	34.96	0.20	0 07:54	0 00:00	0.00	0.00
18 CB 7	0.04	0.04	36.92	0.14	0.00	2.96	36.84	0.06	0 07:55	0 00:00	0.00	0.00
19 CB 8	4.08	0.23	31.34	1.14	0.00	4.50	30.65	0.45	0 07:56	0 00:00	0.00	0.00
20 CB 9	0.28	0.28	33.40	0.28	0.00	2.77	33.27	0.15	0 07:54	0 00:00	0.00	0.00
21 CB_10	1.51	0.28	32.80	0.76	0.00	3.40	32.34	0.30	0 07:55	0 00:00	0.00	0.00
22 CONNECT TO EX CB2	0.25	0.25	35.48	0.27	0.00	0.40	35.36	0.15	0 07:54	0 00:00	0.00	0.00

D2

## Pipe Input

SN	Element ID	Length (ft)	Inlet Invert Elevation (ft)	Inlet Invert Offset (ft)	Outlet Invert Elevation (ft)	Outlet Invert Offset (ft)	Total Drop (ft)	Average Pipe Slope (%)	Pipe Shape	Pipe Diameter or Height (in)	Pipe Width (in)	Manning's Roughness	Entrance Losses	Exit/Bend Losses	Additional Losses	Initial Flap Flow Gate (cfs)	No. of Barrels
1	.5	64.00	32.36	0.00	32.04	0.00	0.32	0.5000	CIRCULAR	12.000	12.000	0.0120	0.5000	0.5000	0.0000	0.00 No	1
2	P - (10)	71.30	28.58	0.00	28.22	3.05	0.36	0.5000	CIRCULAR	18.000	18.000	0.0120	0.5000	0.5000	0.0000	0.00 No	1
3	P - (11)	64.00	33.33	0.00	31.33	-0.50	2.00	3.1300	CIRCULAR	8.040	8.040	0.0120	0.5000	0.5000	0.0000	0.00 No	1
4	P - (12)	64.02	32.15	0.00	31.83	0.00	0.32	0.5000	CIRCULAR	12.000	12.000	0.0120	0.5000	0.5000	0.0000	0.00 No	1
5	P - (13)	64.00	33.12	0.00	30.53	0.33	2.59	4.0500	CIRCULAR	8.040	8.040	0.0120	0.5000	0.5000	0.0000	0.00 No	1
6	P - (14)	64.00	30.20	0.00	32.04	0.00	-1.84	-2.8700	CIRCULAR	12.000	12.000	0.0120	0.5000	0.5000	0.0000	0.00 No	1
7	P - (15)	77.23	33.39	0.00	33.00	0.00	0.39	0.5000	CIRCULAR	12.000	12.000	0.0120	0.5000	0.5000	0.0000	0.00 No	1
8	P - (16)	64.68	33.00	0.00	32.68	0.00	0.32	0.5000	CIRCULAR	12.000	12.000	0.0120	0.5000	0.5000	0.0000	0.00 No	1
9	P - (17)	64.00	32.68	0.00	32.36	0.00	0.32	0.5000	CIRCULAR	12.000	12.000	0.0120	0.5000	0.5000	0.0000	0.00 No	1
10	P - (19)	55.02	36.78	0.00	34.76	0.00	2.02	3.6700	CIRCULAR	8.040	8.040	0.0120	0.5000	0.5000	0.0000	0.00 No	1
11	P - (20)	66.44	34.76	0.00	33.79	-0.54	0.97	1.4600	CIRCULAR	8.040	8.040	0.0120	0.5000	0.5000	0.0000	0.00 No	1
12	P - (21)	64.31	35.21	0.00	34.33	0.34	0.88	1.3600	CIRCULAR	8.040	8.040	0.0120	0.5000	0.5000	0.0000	0.00 No	1
13	P - (25)	26.74	25.17	0.00	24.40	0.00	0.77	2.8800	CIRCULAR	18.000	18.000	0.0120	0.5000	0.5000	0.0000	0.00 No	1
14	P - (26)	70.08	34.20	0.00	30.00	0.83	4.20	5.9900	CIRCULAR	8.040	8.040	0.0120	0.5000	0.5000	0.0000	0.00 No	1
15	P - (27)	97.22	34.00	0.00	32.79	0.00	1.21	1.2400	CIRCULAR	12.000	12.000	0.0120	0.5000	0.5000	0.0000	0.00 No	1
16	P - (3)	108.58	33.44	0.00	32.79	0.00	0.65	0.6000	CIRCULAR	12.000	12.000	0.0120	0.5000	0.5000	0.0000	0.00 No	1
17	P - (4)	63.74	32.79	0.00	32.47	0.00	0.32	0.5000	CIRCULAR	12.000	12.000	0.0120	0.5000	0.5000	0.0000	0.00 No	1
18	P - (5)	64.25	32.47	0.00	32.15	0.00	0.32	0.5000	CIRCULAR	12.000	12.000	0.0120	0.5000	0.5000	0.0000	0.00 No	1
19	P - (6)	225.00	31.83	0.00	30.20	0.00	1.63	0.7200	CIRCULAR	12.000	12.000	0.0120	0.5000	0.5000	0.0000	0.00 No	1
20	P - (7)	206.99	30.20	0.00	29.17	0.00	1.03	0.5000	CIRCULAR	18.000	18.000	0.0120	0.5000	0.5000	0.0000	0.00 No	1
21	P - (8)	63.11	33.79	-0.54	30.00	0.83	3.79	6.0100	CIRCULAR	8.040	8.040	0.0120	0.5000	0.5000	0.0000	0.00 No	1
22	P - (9)	118.56	29.17	0.00	28.58	0.00	0.59	0.5000	CIRCULAR	18.000	18.000	0.0120	0.5000	0.5000	0.0000	0.00 No	1





## Pipe Results

SN Element ID	Peak Flow (cfs)	Time of Peak Flow Occurrence (days hh:mm)	Design Flow Capacity (cfs)	Peak Flow/Design Flow Ratio	Peak Flow Velocity (ft/sec)	Travel Time (min)	Peak Flow Depth (ft)	Peak Flow Depth/Total Depth Ratio	Total Time Surcharged (min)	Froude Number	Reported Condition
1 .5	1.23	0 07:55	2.73	0.45	2.14	0.50	0.72	0.72	0.00		Calculated
2 P - (10)	5.44	0 07:57	8.05	0.68	3.82	0.31	1.13	0.75	0.00		Calculated
3 P - (11)	0.27	0 07:54	2.00	0.13	1.01	1.06	0.47	0.70	0.00		Calculated
4 P - (12)	1.55	0 07:56	2.73	0.57	2.15	0.50	0.86	0.86	0.00		Calculated
5 P - (13)	0.28	0 07:54	2.63	0.11	2.16	0.49	0.47	0.71	0.00		Calculated
6 P - (14)	1.51	0 07:55	6.54	0.23	2.06	0.52	0.88	0.88	0.00		Calculated
7 P - (15)	0.34	0 07:54	2.73	0.12	1.54	0.84	0.33	0.33	0.00		Calculated
8 P - (16)	0.65	0 07:55	2.71	0.24	1.86	0.58	0.48	0.48	0.00		Calculated
9 P - (17)	0.96	0 07:55	2.73	0.35	2.05	0.52	0.63	0.63	0.00		Calculated
10 P - (19)	0.04	0 07:55	2.51	0.02	0.38	2.41	0.32	0.48	0.00		Calculated
11 P - (20)	0.53	0 07:54	1.05	0.50	1.83	0.61	0.55	0.83	0.00		Calculated
12 P - (21)	0.25	0 07:54	1.53	0.17	2.44	0.44	0.23	0.34	0.00		Calculated
13 P - (25)	5.48	0 07:55	19.31	0.28	4.66	0.10	0.95	0.63	0.00		Calculated
14 P - (26)	0.15	0 07:54	3.21	0.05	2.41	0.48	0.34	0.51	0.00		Calculated
15 P - (27)	0.46	0 07:55	4.30	0.11	1.51	1.07	0.46	0.46	0.00		Calculated
16 P - (3)	0.27	0 07:52	2.99	0.09	0.88	2.06	0.42	0.42	0.00		Calculated
17 P - (4)	1.02	0 07:56	2.72	0.37	2.12	0.50	0.65	0.65	0.00		Calculated
18 P - (5)	1.28	0 07:56	2.73	0.47	2.12	0.51	0.74	0.74	0.00		Calculated
19 P - (6)	2.07	0 07:54	3.28	0.63	2.66	1.41	0.97	0.97	0.00		Calculated
20 P - (7)	4.08	0 07:56	8.03	0.51	2.63	1.31	1.23	0.82	0.00		Calculated
21 P - (8)	0.74	0 07:55	3.43	0.22	3.33	0.32	0.55	0.82	0.00		Calculated
22 P - (9)	5.19	0 07:57	8.03	0.65	3.12	0.63	1.34	0.89	0.00		Calculated



# ***Appendix E***

---

- Construction Stormwater Pollution Prevention Plan (CSWPPP)



## **Construction Stormwater Pollution Prevention Plan**

*PREPARED FOR:*

Larson Automotive Group  
1409 Alexander Avenue East  
Fife, WA 98424-1109

*PROJECT:*

Larson River Road Storage  
8424 River Road  
Puyallup, WA 98371  
2160102.10

*PREPARED BY:*

Dan Osier, PE  
Project Engineer

*REVIEWED BY:*

Todd C. Sawin, PE, DBIA, LEED AP  
Principal

*DATE:*

May 2016

## **Construction Stormwater Pollution Prevention Plan**

*PREPARED FOR:*

Larson Automotive Group  
1409 Alexander Avenue East  
Fife, WA 98424-1109

*PROJECT:*

Larson River Road Storage  
8424 River Road  
Puyallup, WA 98371  
2160102.10

*PREPARED BY:*

Dan Osier, PE  
Project Engineer

*REVIEWED BY:*

Todd C. Sawin, PE, DBIA, LEED AP  
Principal

*DATE:*

May 2016



I hereby state that this [Construction Stormwater Pollution Prevention Plan](#) for the [Larson River Road Storage](#) project has been prepared by me or under my supervision, and meets the standard of care and expertise that is usual and customary in this community for professional engineers. I understand that [the City of Puyallup](#) does not and will not assume liability for the sufficiency, suitability, or performance of drainage facilities prepared by me.

**Table of Contents**

---

<b>Section</b>	<b>Page</b>
<b>1.0 Introduction .....</b>	<b>1</b>
<b>2.0 Project Description .....</b>	<b>2</b>
<b>3.0 Existing Site Conditions.....</b>	<b>2</b>
<b>4.0 Adjacent Areas and Drainage .....</b>	<b>2</b>
<b>5.0 Critical Areas .....</b>	<b>2</b>
<b>6.0 Soils.....</b>	<b>2</b>
<b>7.0 Potential Erosion Problems .....</b>	<b>2</b>
<b>8.0 Construction Stormwater Pollution Prevention Elements.....</b>	<b>3</b>
8.1 Mark Clearing Limits .....	3
8.2 Establish Construction Access.....	3
8.3 Control Flow Rates.....	3
8.4 Install Sediment Controls .....	3
8.5 Stabilize Soils.....	3
8.6 Protect Slopes.....	3
8.7 Protect Drain Inlets.....	4
8.8 Stabilize Channels and Outlets.....	4
8.9 Control Pollutants.....	4
8.9.1 Required BMPs .....	5
8.10 Control Dewatering .....	5
8.11 Maintain BMPs.....	6
8.12 Manage the Project.....	6
<b>9.0 Construction Sequence and Phasing .....</b>	<b>7</b>
9.1 Construction Sequence.....	7
9.2 Construction Phasing.....	7
<b>10.0 Construction Schedule.....</b>	<b>7</b>
<b>11.0 Financial/Ownership Responsibilities .....</b>	<b>8</b>
<b>12.0 Certified Erosion and Sediment Control Lead (CESCL) .....</b>	<b>8</b>



# Exhibits

---

## Exhibit 1

- A-1..... Vicinity Map
- A-2..... Existing Conditions Map
- A-3..... FEMA Flood Map
- A-4..... TESC Plan
- A-5..... TESC Notes and Details

## Exhibit 2

### Inspection Logs

## Exhibit 3

### Best Management Practices (BMPs)

- BMP C105..... Stabilized Construction Entrance
- BMP C120..... Temporary and Permanent Seeding
- BMP C121..... Mulching
- BMP C123..... Plastic Covering
- BMP C140..... Dust Control
- BMP C151..... Concrete Handling
- BMP C152..... Sawcutting and Surface Pollution Prevention
- BMP C160..... Certified Erosion and Sediment Control Lead
- BMP C220..... Storm Drain Inlet Protection
- BMP C233..... Silt Fence

## 1.0 Introduction

In 1972, Congress passed the Federal Water Pollution Control Act (FWPCA), also known as the Clean Water Act (CWA), to restore and maintain the quality of the nation's waterways. The ultimate goal was to make sure that rivers and streams were fishable, swimmable, and drinkable. In 1987, the Water Quality Act (WQA) added provisions to the CWA that allowed the Environmental Protection Agency to govern stormwater discharges from construction sites. The National Pollutant Discharge Elimination System (NPDES) General Permit includes provisions for development of a Stormwater Pollution Prevention Plan (SWPPP) to maximize the potential benefits of pollution prevention and sediment and erosion control measures at construction sites.

The proposed project will disturb more than 1 acre of area, and therefore is required to obtain an NPDES General Permit for Stormwater Associated with Construction Activities.

The 2005 Department of Ecology (DOE) *Stormwater Management Manual for Western Washington (SMMWW)* requires a Construction SWPPP for projects that add or replace more than 2,000 square feet of impervious surfaces. The proposed project will exceed this threshold; therefore, a Construction SWPPP is required.

Development, implementation, and maintenance of the Construction SWPPP will provide the selected General Contractor with the framework for reducing soil erosion and minimizing pollutants in stormwater during construction of the proposed project. The Construction SWPPP will:

- Define the characteristics of the site and the type of construction that will occur.
- Describe the practices that will be implemented to control erosion and the release of pollutants in stormwater.
- Create an implementation schedule to ensure that the practices described in this Construction SWPPP are in fact implemented, and to evaluate the plan's effectiveness in reducing erosion, sediment, and pollutant levels in stormwater discharged from the site.
- Describe the final stabilization/termination design to minimize erosion and prevent stormwater impacts after construction is complete.

This Construction SWPPP:

- Identifies the SWPPP Coordinator with a description of this person's duties.
- Identifies the Stormwater Pollution Prevention Team (SWPP Team) that will assist in implementation of the Construction SWPPP during construction.
- Describes the existing site conditions, including existing land use for the site, the soil types at the site, as well as the location of surface waters that are located on or next to the site.
- Identifies the body or bodies of water that will receive runoff from the construction site, including the ultimate body of water that receives the stormwater.
- Identifies the drainage areas and potential stormwater contaminants.
- Describes the stormwater management controls and various Best Management Practices (BMPs) necessary to reduce erosion, sediment, and pollutants in stormwater discharge.
- Describes the facility monitoring plan and how controls will be coordinated with construction activities.
- Describes the implementation schedule and provisions for amendment of the plan.

## **2.0 Project Description**

The Larson River Road Storage project proposes to develop an approximately 1.96-acre site located on Tax Parcels 0420204282 and 0420204069 in the city of Puyallup, Washington. The site is located within the NE Quarter of the SE Quarter of the NE Quarter of Section 20, Township 20N, Range 4E, of the Willamette Meridian (see Exhibit A-1 for the Vicinity Map).

The developed site includes paved vehicle storage areas and utilities. Perimeter landscape will be provided, as required by the City of Puyallup. This paved area shall discharge to one of three proposed catch basins located at the storage lot's proposed low points. Runoff collected in these three catch basins shall be treated using a Contech 72-inch StormFilter manhole with seven 18-inch cartridges prior to discharging east to the existing storm trunk line located below 15<sup>th</sup> Street NW, which discharges into the Puyallup River.

The proposal will follow the stormwater management design criteria outlined in the DOE 2005 *SMMWW*. Control methods during construction include working during the dry season, minimizing the amount of area that is disturbed at any given time, installing a stabilized construction entrance, placing inlet protection at catch basins, and utilizing silt fence at the perimeter of the site, if necessary.

## **3.0 Existing Site Conditions**

The existing area is approximately 1.96 acres and is currently unpaved, with both gravel and grass cover. The site discharges to an existing depression on the eastern side of the site through sheet flow and conveyance through several catch basins. Due to the poor condition of the existing stormwater facilities, it is unknown where the ultimate discharge location of the project site is. However, it appears that stormwater likely ponds until it infiltrates onsite. A topographic survey of the project site area was prepared by AHBL and shows existing site conditions and elevations. See Exhibit 1, A-2 for the Existing Conditions Map.

## **4.0 Adjacent Areas and Drainage**

The site is bordered by developed businesses to the north and northeast, multi-family housing on the northern half of the western border, undeveloped land on the southern half of the western border, single-family housing south of the project site, and undeveloped land to the east.

## **5.0 Critical Areas**

There are no known critical areas on or near the project site. The Puyallup River is approximately 320 feet from the northeast corner of the site.

## **6.0 Soils**

Soil conditions for the site are classified as predominantly Puyallup fine sandy loam by the Natural Resources Conservation Service (NRCS).

## **7.0 Potential Erosion Problems**

There are no known erosion problems at or near the site.



## **8.0 Construction Stormwater Pollution Prevention Elements**

The purpose of this section is to describe how each of the 12 Construction Stormwater Pollution Prevention elements has been addressed and to identify the type and location of BMPs used to satisfy the required element. If an element is not applicable to the project, a reason is provided.

### **8.1 Mark Clearing Limits**

Prior to beginning land-disturbing activities, clearing limits will be marked with high visibility plastic or metal fence (BMP C103). Native vegetation located within the required buffers surrounding the private site shall be protected where practical.

### **8.2 Establish Construction Access**

A stabilized construction entrance (BMP C105) is proposed from River Road through Tax Parcel 0420204281, entering the project site through the northwest corner. If sediment is transported onto the road surface, the road shall be cleaned each day by shoveling or sweeping prior to washing. Sediment removal by washing alone will not be allowed. If sediment is tracked from the site, the City of Puyallup may require stabilization of internal roads and car storage areas to contain the sediment or require the installation of a wheel wash basin.

### **8.3 Control Flow Rates**

The minimal runoff from the construction site will be contained onsite using the proposed methods shown on the Temporary Erosion and Sedimentation Control (TESC) Plan (see Exhibit 1, A-4).

### **8.4 Install Sediment Controls**

As part of the initial construction activities, BMPs will be installed to trap sediment onsite. The identified BMPs include Silt Fencing (BMP C233) and use of Inlet Protection (BMP C220) for existing catch basins and proposed catch basins within the project area and in adjacent streets that may receive runoff.

### **8.5 Stabilize Soils**

Exposed areas and soil stockpiles must be stabilized according to the following schedule:

1. From April 1 to October 31, all disturbed areas at final grade and all exposed areas that are scheduled to remain unworked for more than 30 days shall be stabilized within 10 days.
2. From November 1 to March 31, all exposed soils at final grade shall be stabilized immediately using permanent or temporary measures. Exposed soils with an area greater than 5,000 square feet that are scheduled to remain unworked for more than 24 hours, and exposed areas of less than 5,000 square feet that will remain unworked for more than 7 days shall be stabilized immediately.

All disturbed areas that are not planned to be constructed on within 90 days from time of clearing and grading shall be revegetated with the native vegetation.

### **8.6 Protect Slopes**

The existing site has already been developed and is relatively flat. Soil stabilization BMPs shown in Section 8.5 will be adequate to protect exposed slopes.

## 8.7 Protect Drain Inlets

Storm drain inlets shall be protected so that surface water runoff does not enter the conveyance system without first being filtered. Inlets shall be inspected weekly, at a minimum, and daily during storm events. Storm Drain Inlet Protection (BMP C220) will be provided.

## 8.8 Stabilize Channels and Outlets

Proposed outlets will be connected to existing stormwater facilities.

## 8.9 Control Pollutants

All waste materials will be collected and stored in a securely closed metal dumpster. All trash and construction debris from the site will be deposited in the dumpster. The dumpster will be emptied a minimum of once per week, and the trash will be hauled to the local landfill. No construction materials will be buried onsite. All personnel will be instructed regarding the correct procedure for waste disposal. All sanitary waste will be collected from the portable units a minimum of three times per week. Good housekeeping and spill control practices will be followed during construction to minimize stormwater contamination from petroleum products, fertilizers, and concrete.

Table 1 below lists several pollutants that are commonly found on construction sites that have the potential to contaminate storm runoff. These pollutants will be present, mainly in areas of building and pavement construction. The Contractor and the SWPPP/TESC Coordinator will be responsible for identifying areas where these pollutants are being used and monitor runoff coming from these areas. Pollutant sources will be covered with plastic if contaminated runoff is observed from these areas. If contaminated runoff is found in the sediment trap or soils, the Erosion Control Specialist will direct the Contractor to remove the polluted water/soil and dispose of it in an approved area offsite.

**Table 1 – Potential Construction Site Stormwater Pollutants**

Trade Name Material	Chemical/Physical Description <sup>(1)</sup>	Stormwater Pollutants <sup>(1)</sup>
Pesticides (insecticides, fungicides, herbicide, rodenticides)	Various colored to colorless liquid, powder, pellets, or grains	Chlorinated hydrocarbons, organophosphates, carbamates, arsenic
Fertilizer	Liquid or solid grains	Nitrogen, phosphorous
Plaster	White granules or powder	Calcium sulphate, calcium carbonate, sulfuric acid
Cleaning solvents	Colorless, blue, or yellow-green liquid	Perchloroethylene, methylene chloride, trichloroethylene, petroleum distillates
Asphalt	Black solid	Oil, petroleum distillates
Concrete	White solid	Limestone, sand
Glue, adhesives	White or yellow liquid	Polymers, epoxies
Paints	Various colored liquid	Metal oxides, Stoddard solvent, talc, calcium carbonate, arsenic
Curing compounds	Creamy white liquid	Naphtha
Wastewater from construction equipment washing	Water	Soil, oil & grease, solids
Wood preservatives	Clear amber or dark brown liquid	Stoddard solvent, petroleum distillates, arsenic, copper, chromium
Hydraulic oil/fluids	Brown oily petroleum hydrocarbon	Mineral oil
Gasoline	Colorless, pale brown or pink petroleum hydrocarbon	Benzene, ethyl benzene, toluene, xylene, MTBE

Trade Name Material	Chemical/Physical Description <sup>(1)</sup>	Stormwater Pollutants <sup>(1)</sup>
Diesel fuel	Clear, blue-green to yellow liquid	Petroleum distillate, oil & grease, naphthalene, xylenes
Kerosene	Pale yellow liquid petroleum hydrocarbon	Coal oil, petroleum distillates
Antifreeze/coolant	Clear green/yellow liquid	Ethylene glycol, propylene glycol, heavy metals (copper, lead, zinc)
Erosion	Solid Particles	Soil, Sediment

<sup>(1)</sup> Data obtained from MSDS when available

### 8.9.1 Required BMPs

The following BMPs or equivalent measures are required of all businesses and agencies during concrete pouring and asphalt application at temporary sites:

- Employees must be educated on the pollution hazards of concrete and asphalt application and cutting.
- Loose aggregate chunks and dust must be swept or shoveled and collected (not hosed down a storm drain) for recycling or proper disposal at the end of each work day, especially at work sites such as streets, driveways, parking lots, sidewalks, curbs, and gutters where rain can readily pick up the loose material and carry it to the nearest stormwater conveyance. Small amounts of excess concrete, grout, and mortar can be disposed of in the trash.
- Storm drain covers or similarly effective containment devices must be placed over all nearby drains at the beginning of each day. Shovel or vacuum slurry and remove from the site. All accumulated runoff and solids must be collected and properly disposed at the end of each workday, or more often if necessary.
- Exposed aggregate washing, where the top layer of unhardened concrete is hosed or scraped off to leave a rough finish, must be done with a mechanism for containment and collection of the discarded concrete slurry (such as the storm drain covers mentioned above). The easiest way to contain the washwater will be to direct the washings to a hole in the ground where the water can percolate into the ground and the solids later covered with soil.
- If directed to a drain, a catch basin filter insert must be used to remove the solids. This is especially useful if the activity must proceed on rainy days.
- Cleaning of concrete application and mixing equipment or concrete vehicles on the work site must be done in a designated area where the rinse water is controlled. The rinse water must either be collected for proper disposal or put into a hole in the ground where the water can percolate away and the solids later covered with soil or recovered and disposed or recycled.

The use of any treatment BMP must not result in the violation of groundwater, surface water, or drinking water quality standards.

### 8.10 Control Dewatering

If groundwater is encountered during construction, dewatering control measures shall be used to prevent untreated discharge of sediment-laden water. Measures may include vehicle transport offsite for legal disposal in a manner that does not pollute surface waters, or use of a sedimentation bag with outfall to a ditch or swale for small volumes of localized dewatering.

### **8.11 Maintain BMPs**

Temporary and permanent erosion and sediment control BMPs shall be maintained and repaired as needed to assure performance of their intended functions.

Sediment control BMPs such as silt fencing and drain inlet protection shall be inspected weekly or after a runoff-producing event. Temporary erosion and sediment control BMPs will be removed within 30 days after final site stabilization is achieved. The following inspection and maintenance practices will be used to maintain erosion and sediment controls:

- Built-up sediment will be removed from silt fencing when it has reached one-third the height of the fence.
- Silt fences will be inspected for depth of sediment, tears in the fabric, attachment to the fence posts, and to determine that fence posts are firmly in the ground. Accumulated sediment will be removed from behind the fence.
- Temporary and permanent seeding will be inspected for bare spots, washouts, and healthy growth.
- The Contractor Certified Erosion and Sedimentation Control Lead (CESCL) will provide erosion control inspection services and stormwater disposal monitoring through construction. The City Inspector will be notified of daily construction activities and scheduled meetings between the Erosion Control Inspector and the Contractor.

The maintenance inspection report will be made after each inspection. Copies of the report forms to be completed by the SWPPP Coordinator are attached as Exhibit 2 of this Construction SWPPP. Completed forms will be provided to the City Inspector and will also be maintained onsite during the entire construction project. If construction activities or design modifications are made to the site plan that could impact stormwater, or if AHBL determines that the measures are not adequate to prevent erosion and the discharge of sediment from the site (based on turbidity measurements), this Construction SWPPP will be amended appropriately. The amended Construction SWPPP will have a description of the new activities that contribute to the increased pollutant loading and the planned source control activities.

### **8.12 Manage the Project**

The following practices will be required during construction to properly manage activities:

- Comply with seasonal work limitations.
- Inspect, maintain, and repair BMPs.
- Identify a Certified Erosion and Sediment Control Lead (CESCL).
- Maintain the Construction SWPPP onsite at all times, including narrative and plans.

## **9.0 Construction Sequence and Phasing**

### **9.1 Construction Sequence**

The construction sequence is described below:

1. Arrange and attend a pre-construction meeting with the City of Puyallup.
2. Stake/flag clearing and construction limits.
3. Construct all temporary erosion control BMPs according to the TESC plan. Install inlet sediment protection in existing catch basins.
4. Install construction entrance.
5. Demolish existing site features indicated for removal.
6. Maintain erosion control measures in accordance with City of Puyallup standards and manufacturer recommendations.
7. Rough grade and fill site. All grading shall be done in conformance with the grading plan.
8. Construct storm system and install inlet sediment protection to new basins.
9. Install all remaining site utilities and associated infrastructure.
10. Apply erosion control mulch and seeding, straw mulch or equal, to areas that will not be brought to final grade or permanently vegetated within 7 days of exposure during the dry season, and 2 days of exposure during the wet season (October 1 – April 30).
11. Relocate erosion control measures or install new measures so that, as the site conditions change, the erosion and sediment control is always in accordance with the City of Puyallup Construction SWPPP minimum requirements.
12. Final grade site and install final surface treatments. Ensure that surface water is positively directed toward proposed storm collection facilities.
13. Remove remaining temporary erosion control items once site has been stabilized and upon approval of the City of Puyallup.

### **9.2 Construction Phasing**

Work under this permit will be constructed in a single phase.

## **10.0 Construction Schedule**

Construction is scheduled to begin in summer of 2016 and is expected to be completed in fall of 2016. The majority of earth moving activities will be scheduled during the dry season. During construction, measures will be taken to prevent the transportation of sediment from the site to receiving waters. These measures include the use of:

- Stabilized Construction Entrance (BMP C105)
- Temporary and Permanent Seeding (BMP C120)
- Mulching (BMP C121)

- Plastic Covering (BMP C123)
- Dust Control (BMP C140)
- Storm Drain Inlet Protection (BMP C220)
- Silt Fence (BMP C233)

## 11.0 Financial/Ownership Responsibilities

The contractor is responsible for obtaining performance and maintenance bonds in accordance with City of Puyallup requirements.

## 12.0 Certified Erosion and Sediment Control Lead (CESCL)

The General Contractor shall be required to provide a CESCL prior to construction. Once this individual is identified, the City Inspector will be notified.

The Contractor will designate their CESCL here:

Name: \_\_\_\_\_

Address: \_\_\_\_\_

Phone: \_\_\_\_\_

Fax Number: \_\_\_\_\_

The CESCL is required to meet DOE certification requirements. The City Inspector will be provided with CESCL information.

The duties of the CESCL include:

- Implement the Construction SWPPP/TESC plan with the aid of the SWPP Team.
- Oversee maintenance practices identified as BMPs in the Construction SWPPP.
- Conduct or provide for inspection and monitoring activities.
- Sample stormwater for turbidity using a turbidity meter.
- Identify other potential pollutant sources and make sure they are added to the plan.
- Identify any deficiencies in the Construction SWPPP and make sure they are corrected.
- Ensure that any changes in construction plans are addressed in the Construction SWPPP.

To aid in the implementation of the Construction SWPPP, the members of the SWPP Team include the following: General Contractor, CESCL, City of Puyallup Inspector, City of Puyallup, the geotechnical engineering consultant, and AHBL.

The General Contractor will ensure that all housekeeping and monitoring procedures are implemented, while the CESCL will ensure the integrity of the structural BMPs. The SWPP Team will observe construction and erosion control practices and recommend revisions or additions to the Construction SWPPP and drawings.

This analysis is based on data and records either supplied to or obtained by AHBL, Inc. These documents are referenced within the text of the analysis. The analysis has been prepared utilizing procedures and practices within the standard accepted practices of the industry. We conclude that this project, as proposed, will not create any new problems within the existing downstream drainage system. This project will not noticeably aggravate any existing downstream problems due to either water quality or quantity.

AHBL, Inc.



Dan Osier, PE  
Project Engineer

DJO/lsk

May 2016

Q:\2016\2160102\WORDPROC\Reports\20160518 Rpt (CSWPPP) 2160102.10.docx

# Exhibit 1

---

- A-1.....Vicinity Map
- A-2.....Existing Conditions Map
- A-3.....FEMA Flood Map
- A-4.....TESC Plan
- A-5.....TESC Notes and Details





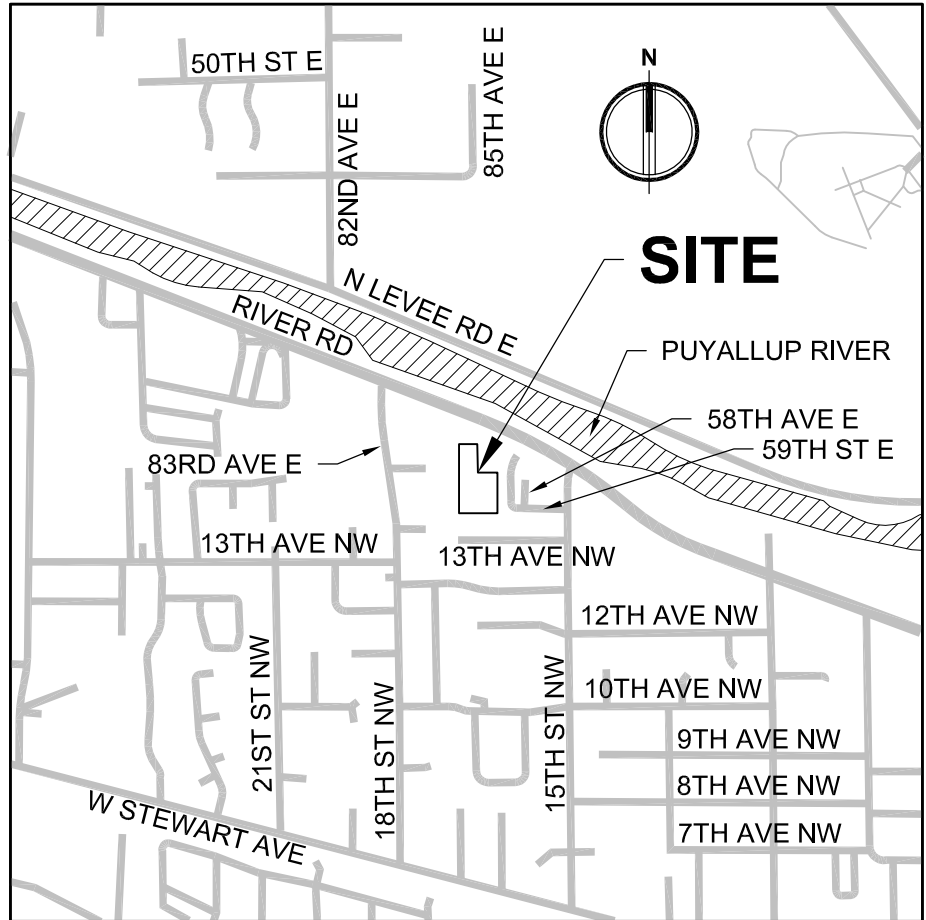

## VICINITY MAP

SCALE: 1" = 1/4 MILE (1320')



TACOMA-SEATTLE  
 2215 North 30th Street, Suite 300, Tacoma, WA 98403 253.383.2422 TEL.  
 316 Occidental Avenue South, Suite 320, Seattle, WA 98104 206.267.2425 TEL.

*Civil Engineers  
 Structural Engineers  
 Landscape Architects  
 Community Planners  
 Land Surveyors  
 Neighbors*

LARSON RIVER ROAD STORATE  
 2160102.10

**VICINITY MAP**  
**05/06/2016**

**A-1**

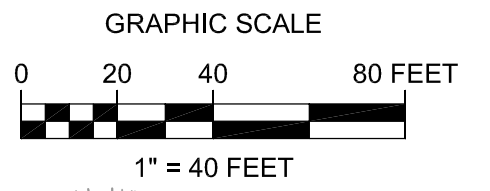
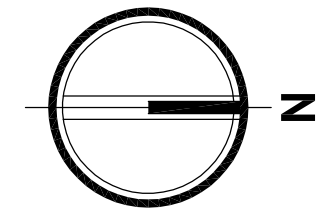

RIVERDANCE  
APN 0420204284

RIVER GLEN  
APN 0420204004

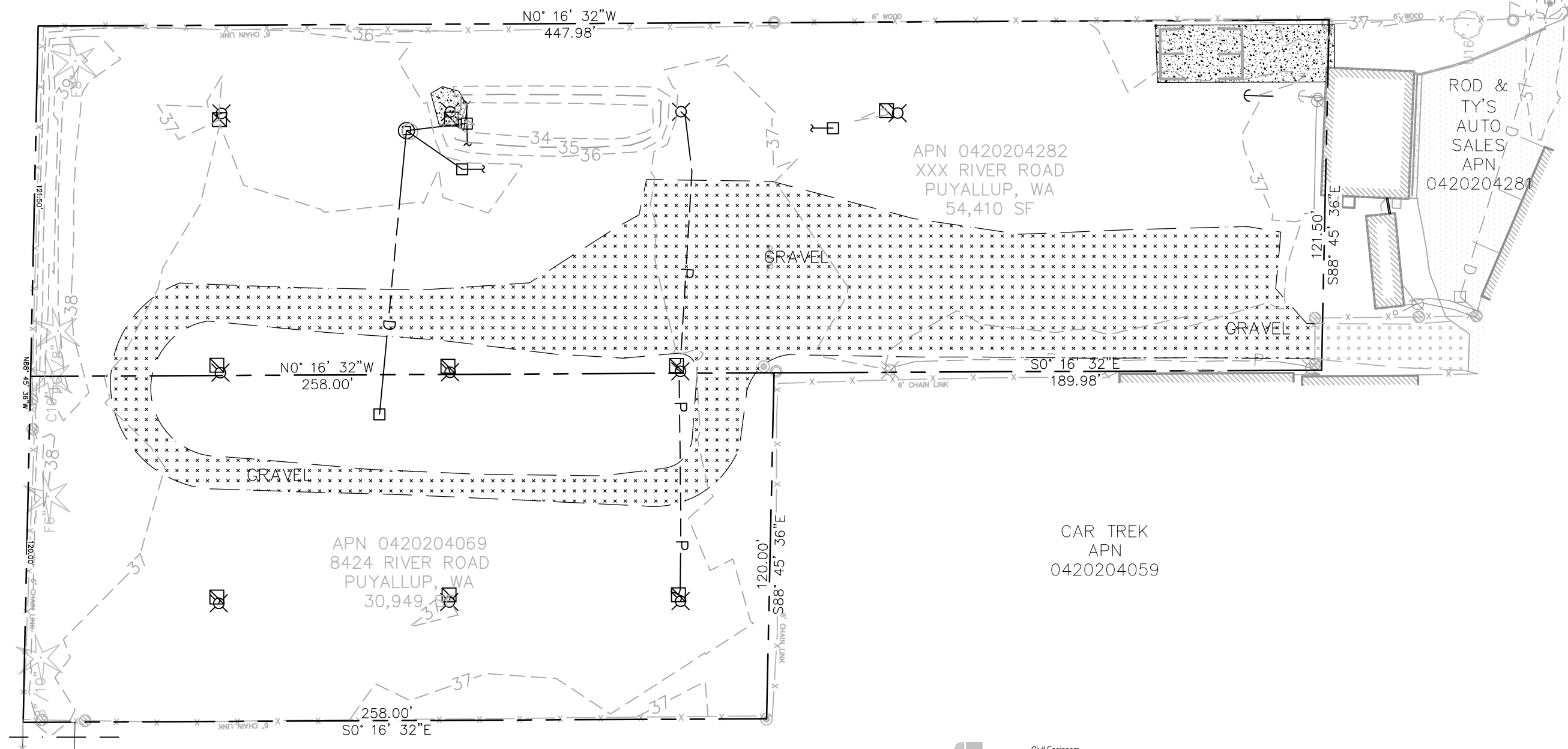

APN 0420204282  
XXX RIVER ROAD  
PUYALLUP, WA  
54,410 SF

APN 0420204069  
8424 RIVER ROAD  
PUYALLUP, WA  
30,949 SF

CAR TREK  
APN  
0420204059



TACOMA · SEATTLE  
2215 North 30th Street, Suite 300, Tacoma, WA 98403 253.383.2422 TEL  
316 Occidental Avenue South, Suite 320, Seattle, WA 98104 206.267.2425 TEL

Civil Engineers  
Structural Engineers  
Landscape Architects  
Community Planners  
Land Surveyors  
Neighbors

LARSON RIVER ROAD STORAGE  
2160102.10  
**EXISTING CONDITIONS MAP**  
**05/13/2016**

**A-2**

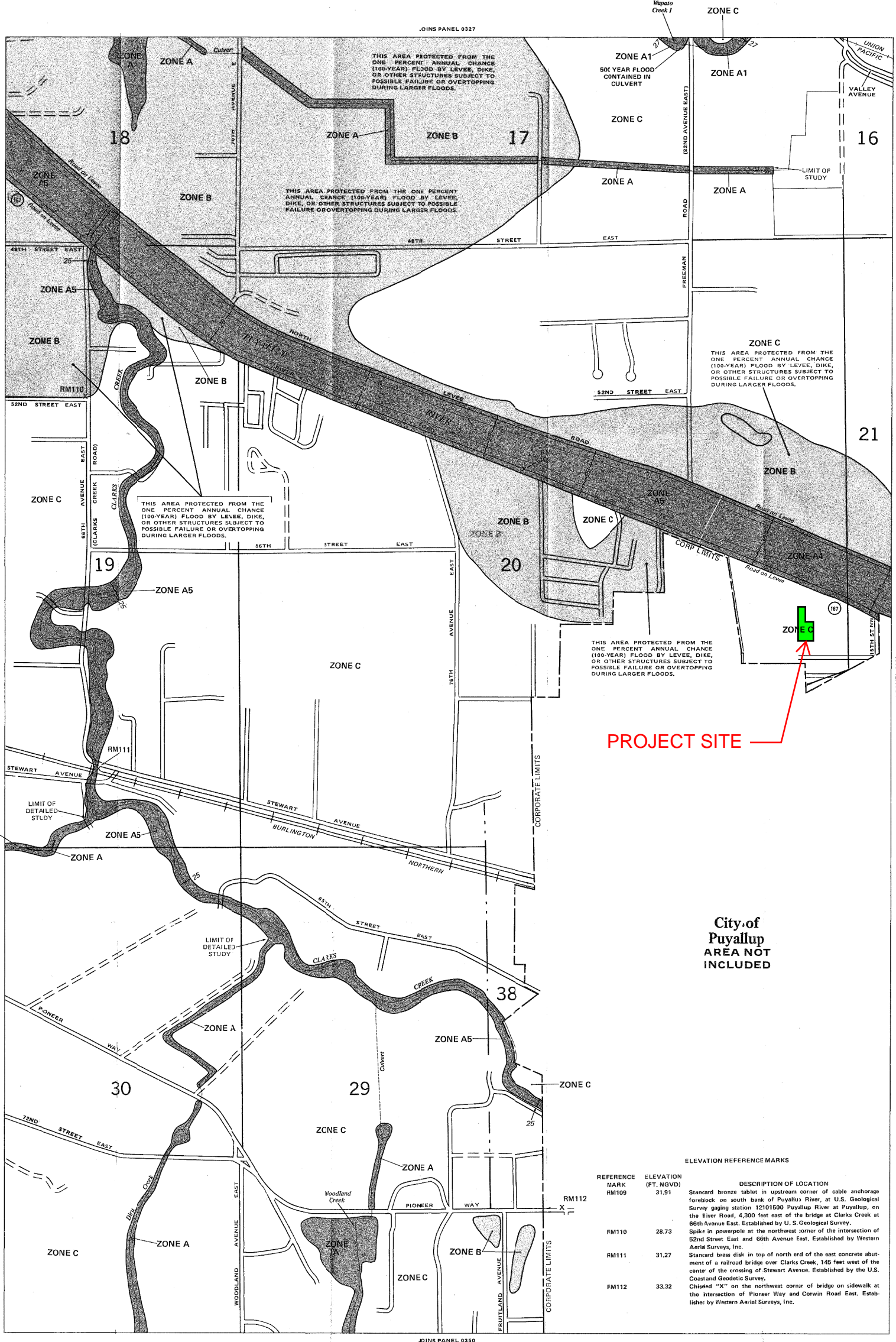

**KEY TO MAP**

500-Year Flood Boundary ———

100-Year Flood Boundary ———

Zone Designations

100-Year Flood Boundary ———

500-Year Flood Boundary ———

Base Flood Elevation Line With Elevation In Feet\*\* ——— 513

Base Flood Elevation In Feet Where Uniform Within Zone\*\* (EL 987)

Elevation Reference Mark RM7x

Zone E Boundary ———

River Mile ——— M1.5

\*\*Referenced to the National Geodetic Vertical Datum of 1929

**EXPLANATION OF ZONE DESIGNATIONS**

ZONE	EXPLANATION
A	Areas of 100-year flood; base flood elevations and flood hazard factors not determined.
A0	Areas of 100-year shallow flooding where depths are between one (1) and three (3) feet; average depths of inundation are shown, but no flood hazard factors are determined.
AH	Areas of 100-year shallow flooding where depths are between one (1) and three (3) feet; base flood elevations are shown, but no flood hazard factors are determined.
A1-A30	Areas of 100-year flood; base flood elevations and flood hazard factors determined.
A99	Areas of 100-year flood to be protected by flood protection system under construction; base flood elevations and flood hazard factors not determined.
B	Areas between limits of the 100-year flood and 500-year flood; or certain areas subject to 100-year flooding with average depths less than one (1) foot or where the contributing drainage area is less than one square mile; or areas protected by levees from the base flood. (Medium shading)
C	Areas of minimal flooding. (No shading)
D	Areas of undetermined, but possible, flood hazards.
V	Areas of 100-year coastal flood with velocity (wave action); base flood elevations and flood hazard factors not determined.
V1-V30	Areas of 100-year coastal flood with velocity (wave action); base flood elevations and flood hazard factors determined.

**NOTES TO USER**

Certain areas not in the special flood hazard areas (zones A and V) may be protected by flood control structures.

This map is for use in administering the National Flood Insurance Program; it does not necessarily identify all areas subject to flooding, particularly from local drainage sources of small size, or all planimetric features outside special flood hazard areas.

Coastal base flood elevations apply only landward of the shoreline shown on this map.

For adjoining map panels, see separately printed Index To Map Panels.

INITIAL IDENTIFICATION: OCTOBER 26, 1977

FLOOD HAZARD BOUNDARY MAP REVISIONS: APRIL 15, 1980

FLOOD INSURANCE RATE MAP EFFECTIVE: AUGUST 19, 1987

Refer to the FLOOD INSURANCE RATE MAP EFFECTIVE date shown on this map to determine when actuarial rates apply to structures in the zones where elevations or depths have been established.

To determine if flood insurance is available in this community, contact your insurance agent, or call the National Flood Insurance Program, at (800) 638-6620.

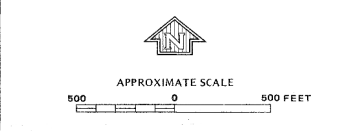

**ELEVATION REFERENCE MARKS**

REFERENCE MARK	ELEVATION (FT. NGVD)	DESCRIPTION OF LOCATION
RM109	31.91	Standard bronze tablet in upstream corner of cable anchorage forelock on south bank of Puyallup River, at U.S. Geological Survey gaging station 12101500 Puyallup River at Puyallup, on the River Road, 4,300 feet east of the bridge at Clark's Creek at 68th Avenue East. Established by U.S. Geological Survey.
FM110	28.73	Spikes in powerpole at the northwest corner of the intersection of 52nd Street East and 68th Avenue East. Established by Western Aerial Surveys, Inc.
RM111	31.27	Standard brass disk in top of north end of the east concrete abutment of a railroad bridge over Clark's Creek, 145 feet west of the center of the crossing of Stewart Avenue. Established by the U.S. Coast and Geodetic Survey.
FM112	33.32	Chisled "X" on the northwest corner of bridge on sidewalk at the intersection of Pioneer Way and Corwin Road East. Established by Western Aerial Surveys, Inc.

NOTE: MAP AREA SHOWN ON THIS PANEL IS LOCATED WITHIN TOWNSHIP 20 NORTH, RANGE 4 EAST

**NATIONAL FLOOD INSURANCE PROGRAM**

**FIRM FLOOD INSURANCE RATE MAP**

**PIERCE COUNTY, WASHINGTON (UNINCORPORATED AREAS)**

**PANEL 329 OF 1375 (SEE MAP INDEX FOR PANELS NOT PRINTED)**

**COMMUNITY-PANEL NUMBER 530138 0329 C**

**EFFECTIVE DATE: AUGUST 19, 1987**

Federal Emergency Management Agency



# LARSON RIVER ROAD STORAGE

A PORTION OF THE NE 1/4 OF THE SE 1/4 OF SEC. 20, TWN. 20 N., RGE. 04 E. W.M.  
CITY OF PUYALLUP, PIERCE COUNTY, WASHINGTON.

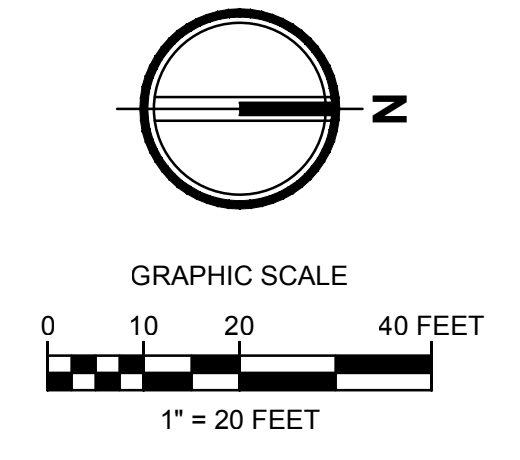

2215 North 30th Street, Suite 300, Tacoma, WA 98403  
253.383.2422 TEL 253.383.2572 FAX www.ahbl.com WEB

Project Title:  
**LARSON RIVER ROAD STORAGE**

Client:  
**LARSON AUTOMOTIVE GROUP**  
1409 ALEXANDER AVENUE EAST  
FIFE, WA 98424-1109  
JOSH LARSON

Job No.  
2160102.10

Issue Set & Date:  
**PERMIT CHECK SET**

05.13.2016



NOTICE  
ALTERATION OF THIS DOCUMENT SHALL INVALIDATE THE PROFESSIONAL SEAL AND REGISTERED PROFESSIONAL STATUS OF THE ENGINEER. THIS DOCUMENT IS FOR THE USE ONLY FOR THE PROJECT DESCRIBED IN THE TITLE BLOCK AND IS NOT TO BE USED FOR OTHER PROJECTS, OR ADDITION TO THAT PROJECT OR FOR ANY OTHER PROJECT.

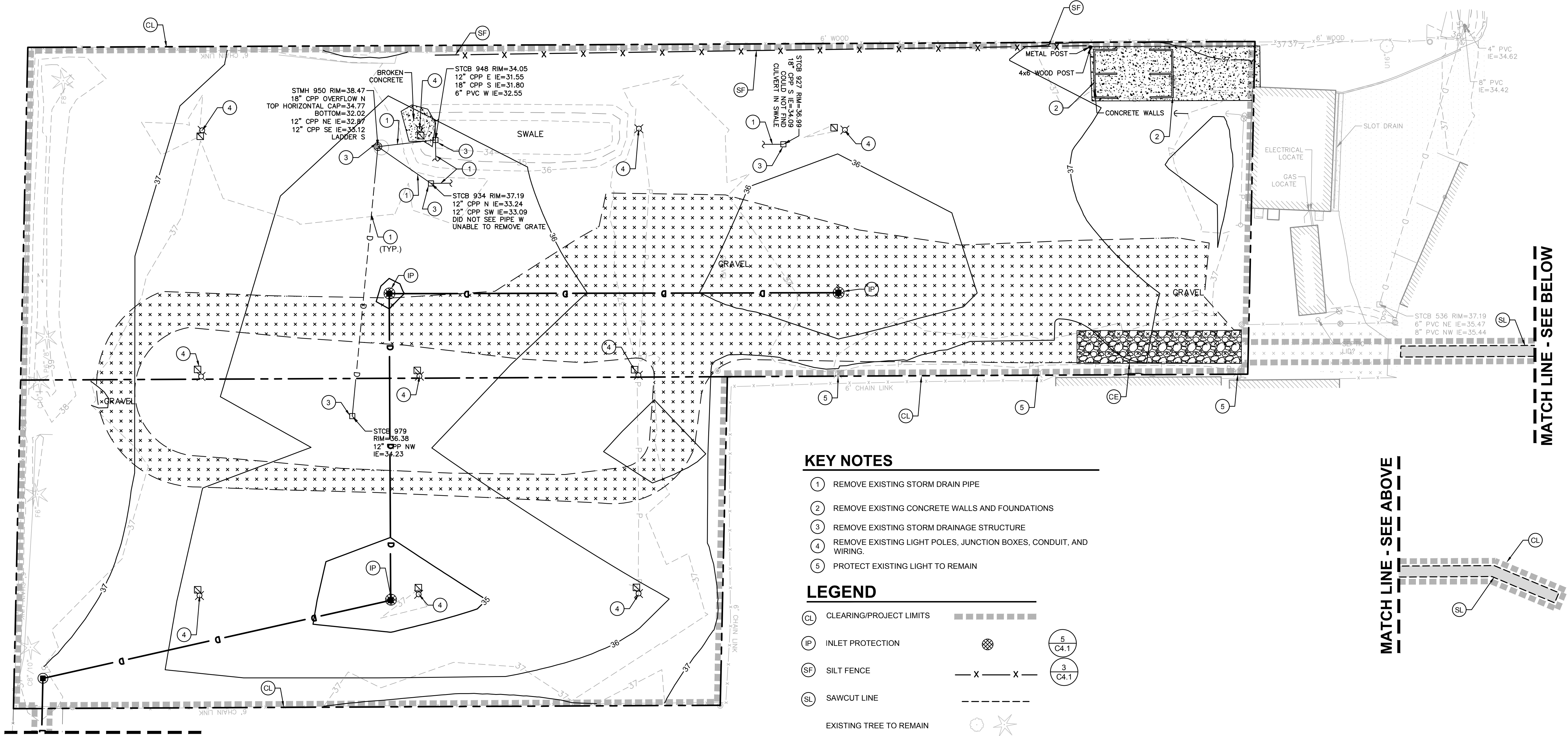

### KEY NOTES

- 1 REMOVE EXISTING STORM DRAIN PIPE
- 2 REMOVE EXISTING CONCRETE WALLS AND FOUNDATIONS
- 3 REMOVE EXISTING STORM DRAINAGE STRUCTURE
- 4 REMOVE EXISTING LIGHT POLES, JUNCTION BOXES, CONDUIT, AND WIRING.
- 5 PROTECT EXISTING LIGHT TO REMAIN

### LEGEND

- CL CLEARING/PROJECT LIMITS
- IP INLET PROTECTION
- SF SILT FENCE
- SL SAWCUT LINE
- EXISTING TREE TO REMAIN
- REMOVE EXISTING ASPHALT
- REMOVE EXISTING CONCRETE
- CE CONSTRUCTION ENTRANCE

MATCH LINE - SEE BELOW

MATCH LINE - SEE ABOVE

MATCH LINE - SEE ABOVE

MATCH LINE - SEE BELOW

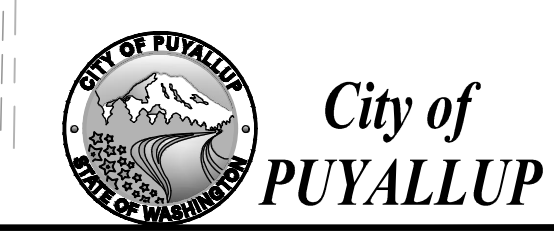
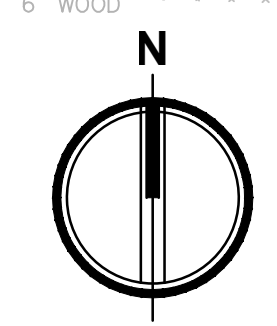
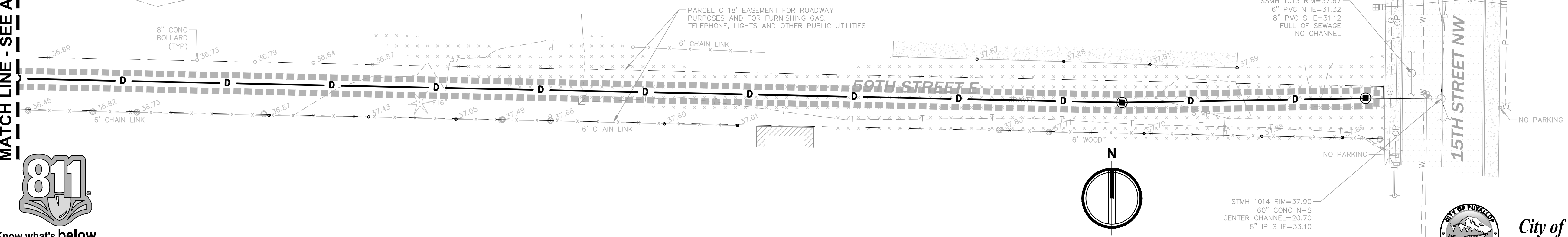

**APPROVED**  
BY: CITY OF PUYALLUP ENGINEERING SERVICES  
DATE:  
NOTE: THIS APPROVAL IS VOID AFTER 1 YEAR FROM APPROVAL DATE. THE CITY WILL NOT BE RESPONSIBLE FOR ERRORS AND/OR OMISSIONS ON THESE PLANS. FIELD CONDITIONS MAY DICTATE CHANGES TO THESE PLANS AS DETERMINED BY THE ENGINEERING SERVICES MANAGER.

Revisions:

Sheet Title:  
**TESC AND DEMOLITION PLAN**

Designed by: Drawn by: Checked by:  
DJO TDS TCS

Sheet No.  
**C1.1**  
2 of 10 Sheets



# LARSON RIVER ROAD STORAGE

## A PORTION OF THE NE 1/4 OF THE SE 1/4 OF SEC. 20, TWN. 20 N., RGE. 04 E. W.M.

### CITY OF PUYALLUP, PIERCE COUNTY, WASHINGTON.

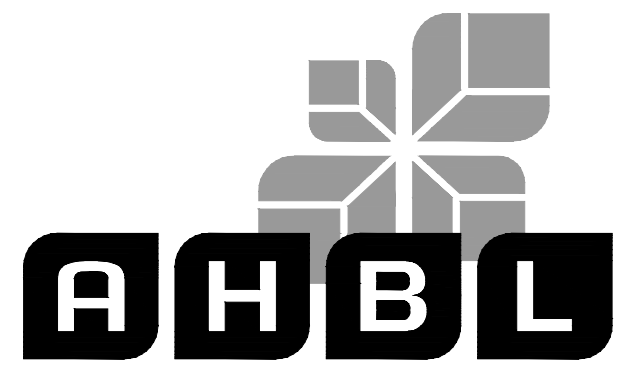

TACOMA · SEATTLE · SPOKANE · TRI-CITIES

2215 North 30th Street, Suite 300, Tacoma, WA 98403  
253.383.2422 TEL 253.383.2572 FAX www.ahbl.com WEB

Project Title:  
**LARSON RIVER ROAD STORAGE**

Client:  
**LARSON AUTOMOTIVE GROUP**

1409 ALEXANDER AVENUE EAST  
FIFE, WA 98424-1109  
JOSH LARSON

Job No.  
2160102.10

Issue Set & Date:  
**PERMIT CHECK SET**

05.13.2016

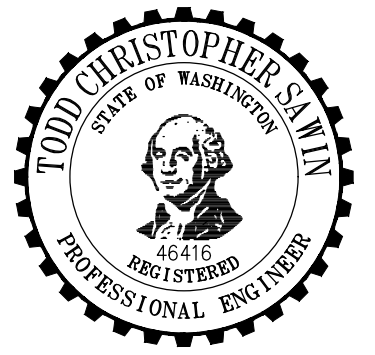

NOTICE  
ALTERATION OF THIS DOCUMENT SHALL INVALIDATE THE PROFESSIONAL SEAL AND SIGNATURE. FALSIFICATION OF THIS DOCUMENT DOES NOT CONSTITUTE FRAUD. THE CONTRACTOR SHALL BE RESPONSIBLE FOR OBTAINING THE NECESSARY PERMITS FOR THE PROJECT AND SHALL BE RESPONSIBLE FOR THE OBTAINMENT OF ANY NECESSARY PERMITS FOR THE PROJECT AND SHALL BE RESPONSIBLE FOR THE OBTAINMENT OF ANY NECESSARY PERMITS FOR THE PROJECT.

Revisions:

Sheet Title:  
**NOTES AND DETAILS**

Designed by: DJO Drawn by: TDS Checked by: TCS

Sheet No.

**C4.1**  
6 of 10 Sheets

**NOTE:**

- GEOTEXTILE MIRAFI 500 X OR APPROVED EQUAL SHALL BE PLACED UNDER THE ENTIRETY OF THE TEMPORARY ENTRANCE.
- ADDITIONAL ROCK SHALL BE ADDED PERIODICALLY TO MAINTAIN PROPER FUNCTION OF THE PAD.
- IF THE PAD DOES NOT ADEQUATELY REMOVE THE MUD FROM THE VEHICLE'S WHEELS, THE WHEELS SHALL BE HOSED OFF BEFORE THE VEHICLE ENTERS A PAVED STREET. THE WASHING SHALL BE DONE ON AN AREA COVERED WITH CRUSHED ROCK AND WASH WATER SHALL DRAIN TO A SEDIMENT RETENTION FACILITY OR THROUGH A SILT FENCE.

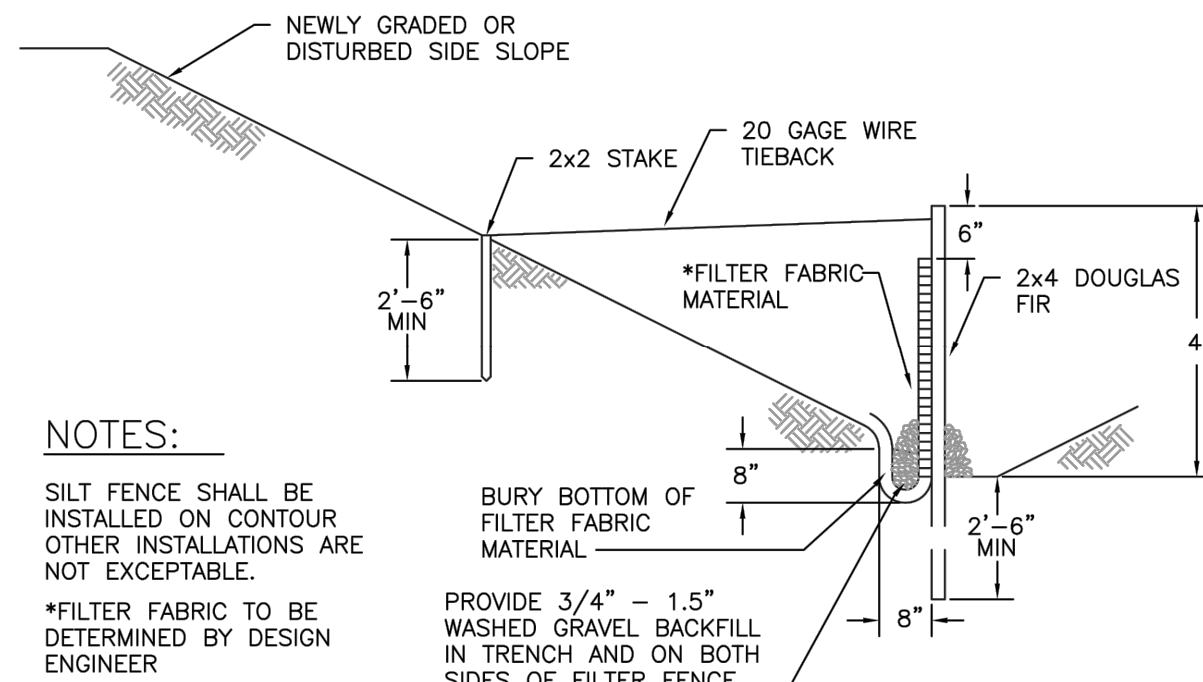
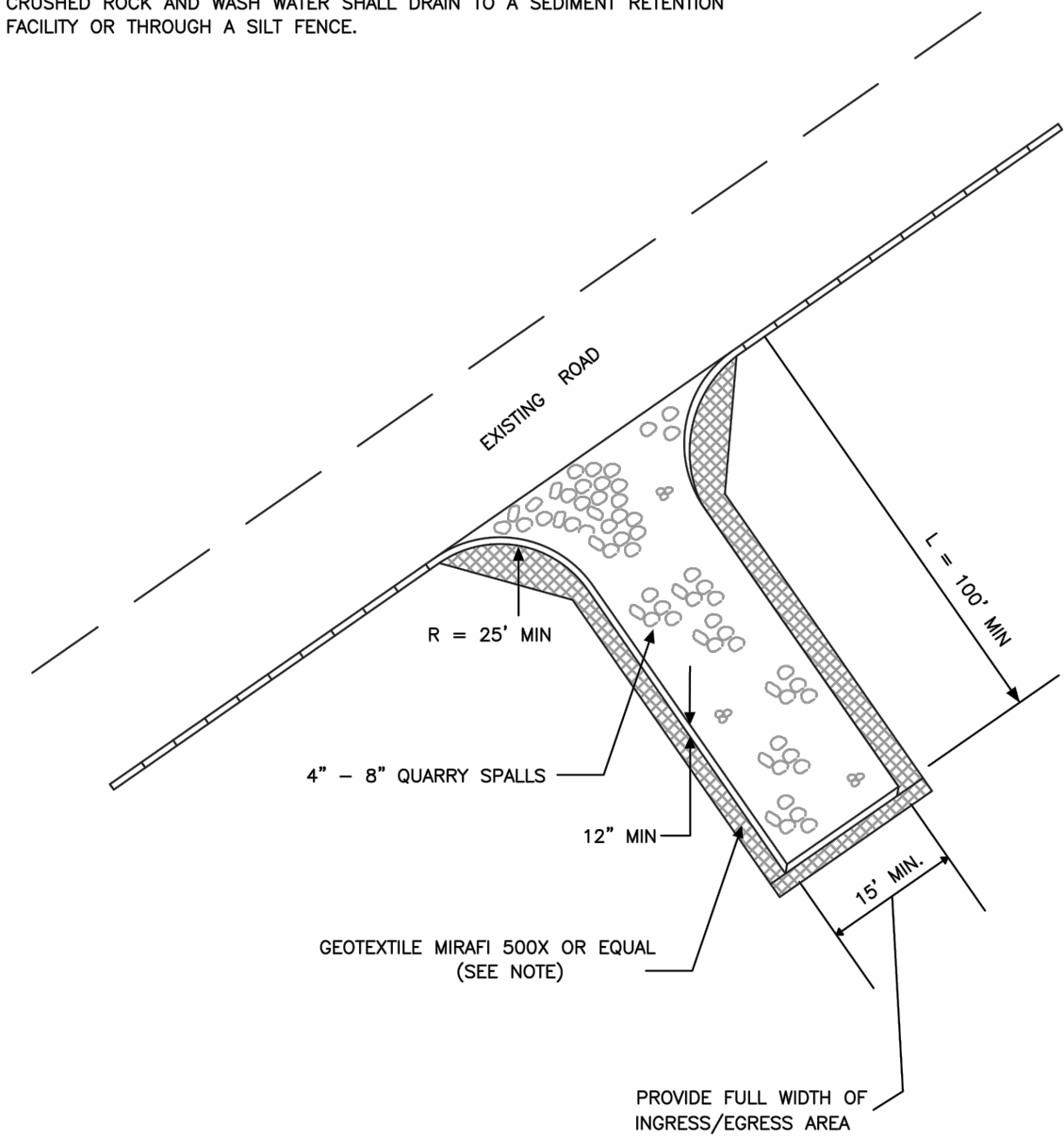

**NOTES:**

- SILT FENCE SHALL BE INSTALLED ON CONTOUR. OTHER INSTALLATIONS ARE NOT EXCEPTABLE.
- \*FILTER FABRIC TO BE DETERMINED BY DESIGN ENGINEER
- PROVIDE 3/4" - 1.5" WASHED GRAVEL BACKFILL IN TRENCH AND ON BOTH SIDES OF FILTER FENCE FABRIC ON THE SURFACE.
- BURY BOTTOM OF FILTER FABRIC MATERIAL
- STAPLES OR WIRE WIRE FABRIC (TYP)
- 2"x2"x14 GA WELDED WIRE FABRIC OR EQUAL
- 2"x4" DOUGLAS FIR AT 4' O.C. NO. 1 GRADE OR EQUAL
- BURY BOTTOM OF FILTER FABRIC MATERIAL ON 8"x8" TRENCH

**TYPICAL CROSS SECTION**

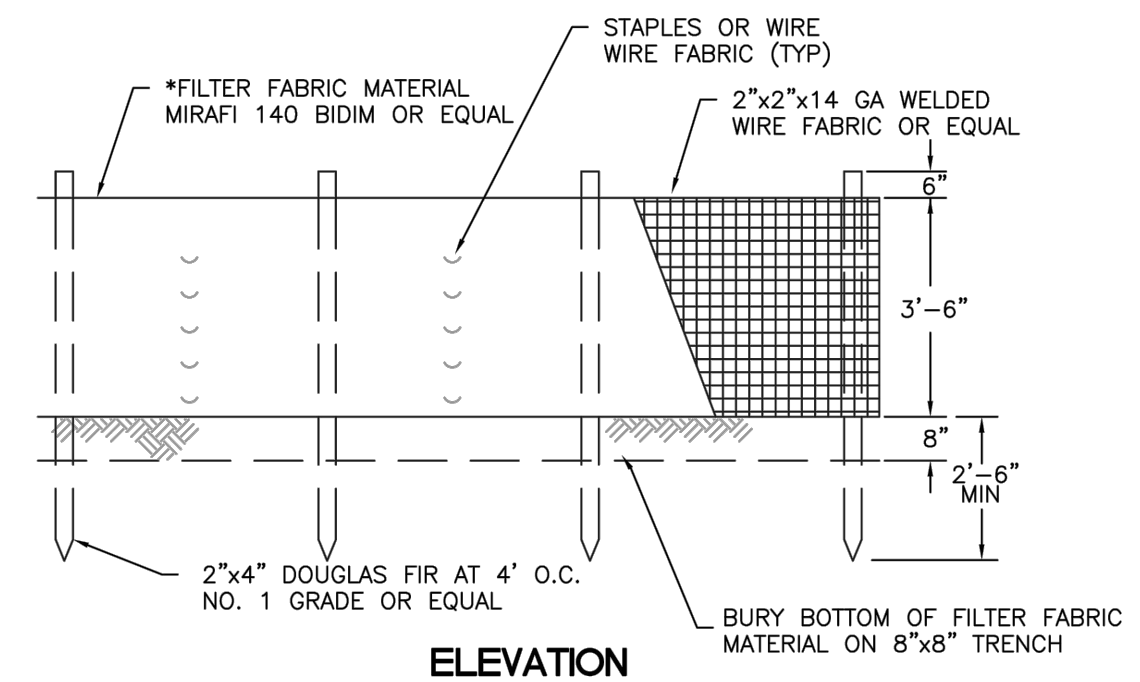

**ELEVATION**

**BLOCK AND GRAVEL FILTER**

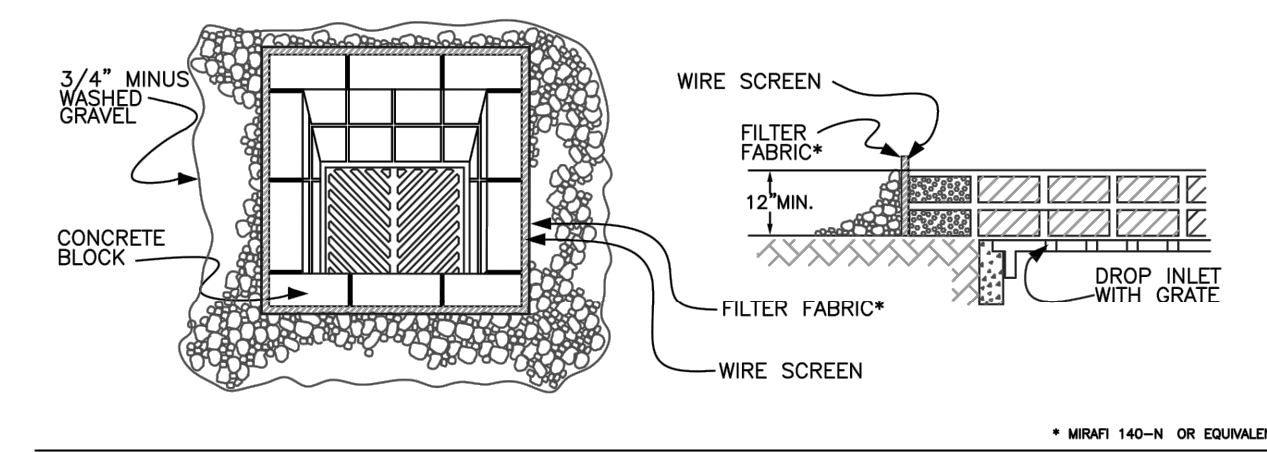

**FILTER FABRIC FENCE**

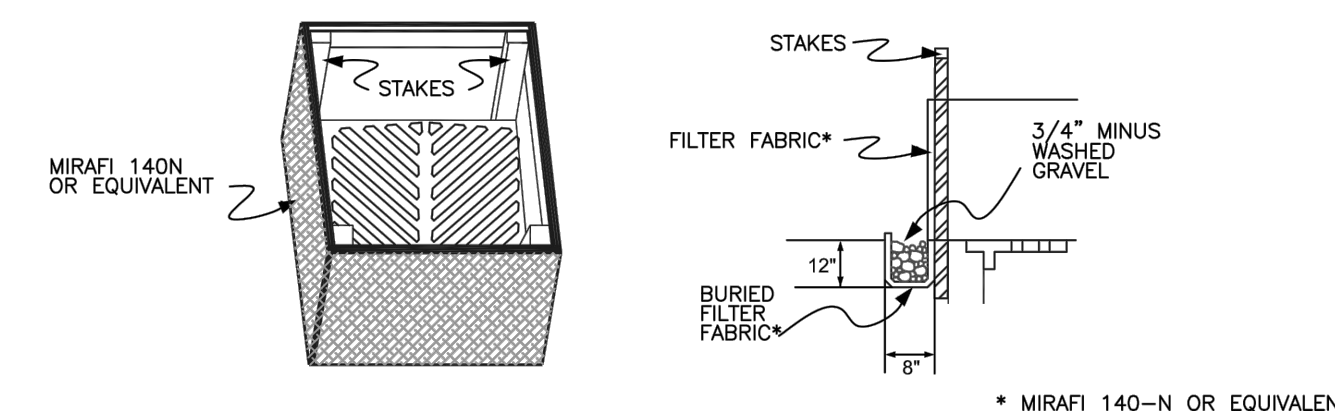

**STRAW BALE BARRIER**

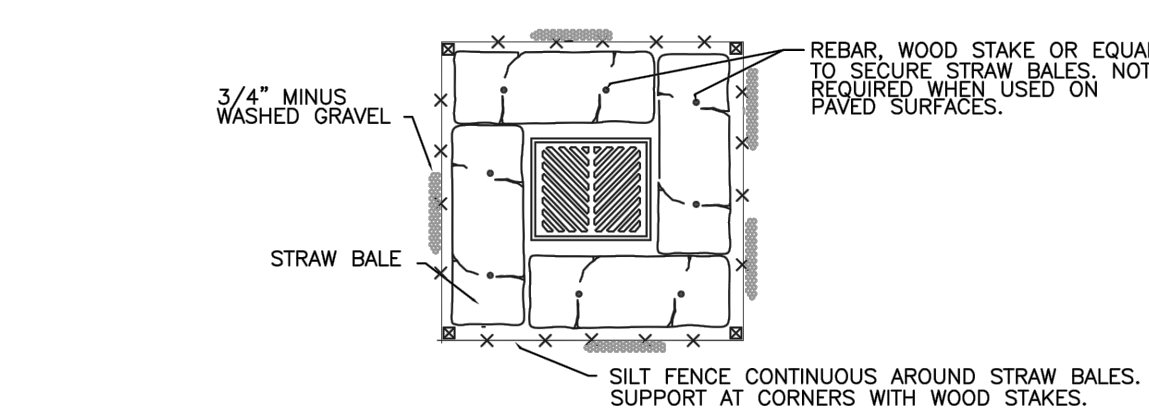

**CONDITIONS WHERE PRACTICE APPLIES**

- BLOCK AND GRAVEL FILTER - APPLICABLE FOR AREAS GREATER THAN 5% SLOPE.
- FILTER FABRIC FENCE - APPLICABLE WHERE THE INLET DRAINS A RELATIVELY SMALL (ONE ACRE OR LESS) AND FLAT AREA (LESS THAN 5% SLOPE).
- STRAW BALE BARRIER - APPLICABLE WHERE INLET DRAINS A RELATIVELY FLAT DISTURBED AREA ( LESS THAN 5% SLOPE) IN WHICH SHEET FLOW (NOT EXCEEDING 0.5 FT/SEC.) OCCURS. BARRIERS OF THIS TYPE SHOULD NOT BE PLACED AROUND INLETS RECEIVING CONCENTRATED FLOWS SUCH AS THOSE ALONG MAJOR STREETS AND HIGHWAYS.

**1. BLOCK AND GRAVEL FILTER - INSTALLATION PROCEDURE**

- PLACE WIRE MESH OVER THE DROP INLET SO THAT THE WIRE EXTENDS A MINIMUM OF ONE FOOT BEYOND EACH SIDE OF THE INLET STRUCTURE. USE WIRE SCREEN WITH 1/2-INCH OPENINGS. IF MORE THAN ONE STRIP OF MESH IS NECESSARY, OVERLAP THE STRIPS. PLACE FILTER FABRIC OVER WIRE MESH.
- PLACE CONCRETE BLOCKS LENGTHWISE ON THEIR SIDES IN A SINGLE ROW AROUND THE PERIMETER OF THE INLET. SO THAT THE OPEN ENDS FACE OUTWARD, NOT UPWARD. THE ENDS OF ADJACENT BLOCKS SHOULD ABUT. THE HEIGHT OF THE BARRIER CAN BE VARIED, DEPENDING ON DESIGN NEEDS, BY STACKING COMBINATIONS OF BLOCKS THAT ARE 4-INCH, 8-INCH AND 12-INCH WIDE. THE ROW OF BLOCKS SHOULD BE AT LEAST 12-INCHES BUT NO GREATER THAN 24-INCHES HIGH.
- PLACE WIRE SCREEN OVER THE OVERSIDE VERTICAL FACE (OPEN END) OF THE CONCRETE BLOCKS TO PREVENT STONES FROM BEING WASHED THROUGH THE BLOCKS. USE WIRE SCREEN WITH 1/2-INCH OPENINGS.
- PILE STONES AGAINST THE WIRE MESH TO THE TOP OF THE BLOCKS. USE 3/4" MINUS WASHED GRAVEL.

**2. FILTER FABRIC FENCE - INSTALLATION PROCEDURE**

- PLACE 2-INCH BY 2-INCH WOODEN STAKES AROUND THE PERIMETER OF THE INLET A MAXIMUM OF 3 FEET APART AND DRIVE THEM AT LEAST 8-INCHES INTO THE GROUND. THE STAKES MUST BE AT LEAST 3 FEET LONG.
- EXCAVATE A TRENCH APPROXIMATELY 8-INCHES WIDE AND 12-INCHES DEEP AROUND THE OUTSIDE PERIMETER OF THE STAKES.
- STAPLE THE FILTER FABRIC TO THE WOODEN STAKES SO THAT 32-INCHES OF THE FABRIC EXTENDS AND CAN BE FORMED INTO THE TRENCH, AND USE HEAVY-DUTY WIRE STAPLES AT LEAST 1/2-INCHES LONG.
- BACKFILL THE TRENCH WITH 3/4-INCH MINUS WASHED GRAVEL ALL THE WAY AROUND.

**3. STRAW BALE BARRIER - INSTALLATION PROCEDURE**

- EXCAVATE A 4-INCH DEEP TRENCH AROUND THE INLET. MAKE THE TRENCH AS WIDE AS A STRAW BALE.
- ORIENT STRAW BALES WITH THE BINDINGS AROUND THE SIDES OF THE BALES RATHER THAN OVER AND UNDER THE BALES.
- PLACE BALES LENGTHWISE AROUND THE INLET AND PRESS THE ENDS OF ADJACENT BALES SECURELY IN PLACE.
- DRIVE TWO 2-INCH BY 2-INCH STAKES THROUGH EACH BALE TO ANCHOR THE BALE SECURELY IN PLACE.
- BACKFILL THE EXCAVATED SOIL AND COMPACT IT AGAINST THE BALE.
- WEDGE LOOSE STRAW BETWEEN BALES TO PREVENT WATER FROM FLOWING BETWEEN BALES.

\* MIRAFI 140-N OR EQUIVALENT

**CITY OF PUYALLUP**  
TEMPORARY CONSTRUCTION ENTRANCE  
DEVELOPMENT ENGINEERING and PUBLIC WORKS DEPARTMENTS  
CHECKED BY: LINDA LIAN  
APPROVED BY: COLLEEN HARRIS  
DATE APPROVED: 05/01/16  
SCALE: AS SHOWN  
05.01.01

**CITY OF PUYALLUP**  
SILTATION FENCE  
DEVELOPMENT ENGINEERING and PUBLIC WORKS DEPARTMENTS  
CHECKED BY: LINDA LIAN  
APPROVED BY: COLLEEN HARRIS  
DATE APPROVED: 04/20/16  
SCALE: AS SHOWN  
02.03.02

**CITY OF PUYALLUP**  
STORM DRAIN BARRIERS  
DEVELOPMENT ENGINEERING and PUBLIC WORKS DEPARTMENTS  
CHECKED BY: LINDA LIAN  
APPROVED BY: COLLEEN HARRIS  
DATE APPROVED: 04/20/16  
SCALE: AS SHOWN  
02.03.05

**CITY OF PUYALLUP**  
STORM DRAIN BARRIERS NOTES  
DEVELOPMENT ENGINEERING and PUBLIC WORKS DEPARTMENTS  
CHECKED BY: LINDA LIAN  
APPROVED BY: COLLEEN HARRIS  
DATE APPROVED: 04/20/16  
SCALE: AS SHOWN  
02.03.06

**1 CONSTRUCTION ENTRANCE**  
NOT TO SCALE

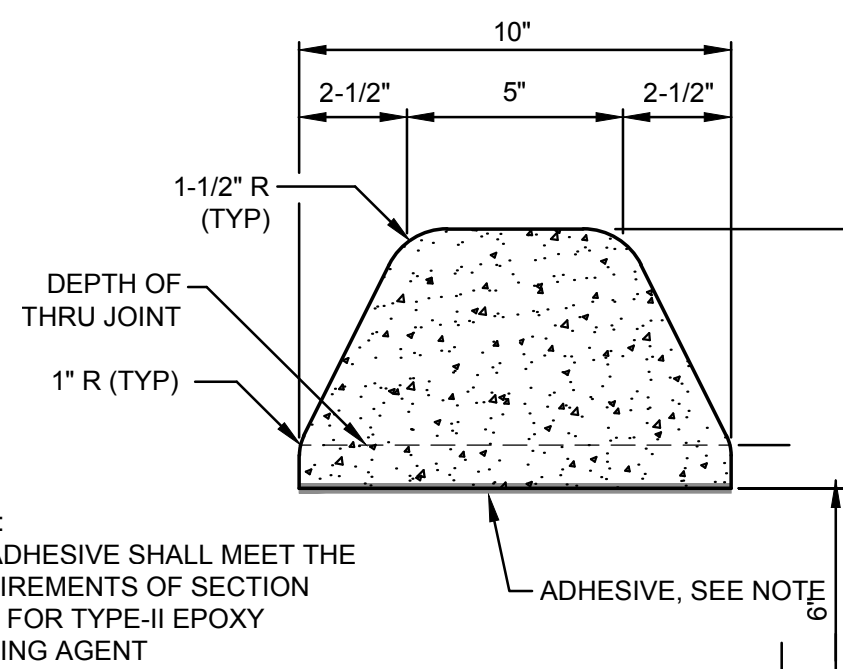

**2 EXTRUDED CURB**  
NOT TO SCALE

**3 SILT FENCE**  
NOT TO SCALE

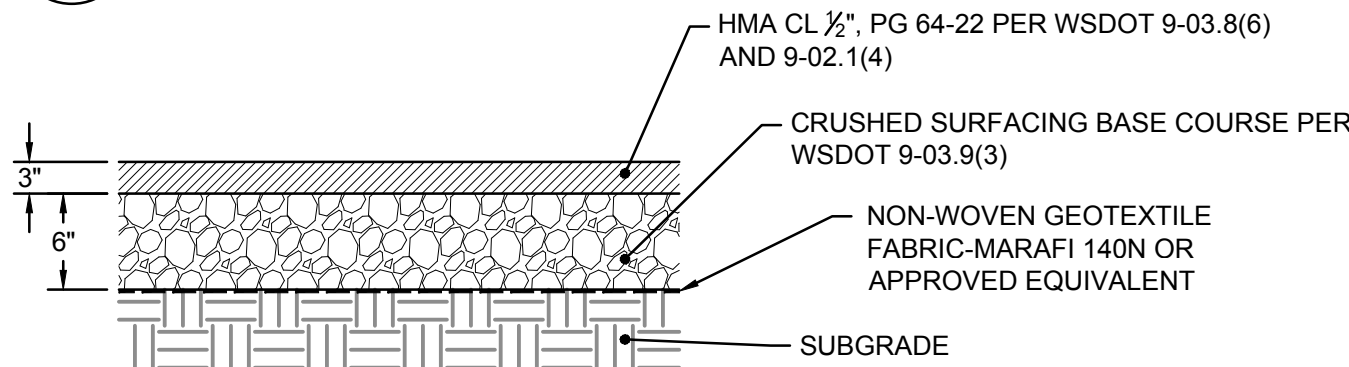

- NOTES:**
- DEPTHS INDICATED ARE COMPACTED THICKNESSES.
  - HMA SHALL BE COMPACTED TO A TARGET AVERAGE DENSITY OF 92% BASED ON THE RICE THEORETICAL MAXIMUM DENSITY PER ASTM D-2041. INDIVIDUAL LOCATIONS SHALL BE COMPACTED NOT LESS THAN 90% NOR MORE THAN 96%.
  - ALL ASPHALT BASE MATERIAL SHALL BE COMPACTED TO A MINIMUM DENSITY OF 95% BASED ON THE MODIFIED PROCTOR MAXIMUM DRY DENSITY PER ASTM D-1557.
  - SUBGRADE SHALL BE COMPACTED TO A FIRM AND UNYIELDING CONDITION PRIOR TO PLACEMENT OF ANY PAVEMENT LAYERS. ANY LOCALIZED ZONES OF SOFT, ORGANIC-RICH, OR DEBRIS-LADEN SOILS SHOULD BE OVEREXCAVATED AND REPLACED WITH STRUCTURAL FILL MATERIAL.

**4 ASPHALT PAVEMENT**  
NOT TO SCALE

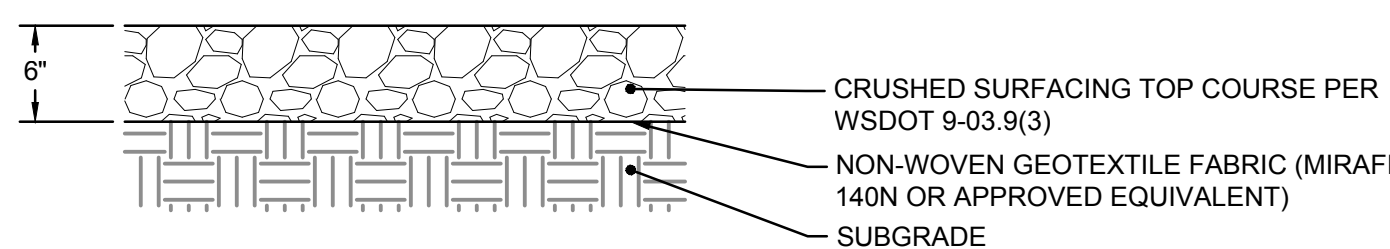

- NOTES:**
- DEPTHS INDICATED ARE COMPACTED THICKNESSES.
  - CRUSHED SURFACING TOP COURSE AND SUBGRADE SHALL BE COMPACTED TO A MINIMUM DENSITY OF 95% BASED ON THE MODIFIED PROCTOR MAXIMUM DRY DENSITY PER ASTM D-1557. IF COMPACTION REQUIREMENT IS NOT MET, EXCAVATE AND REPLACE WITH 6" GRAVEL BASE PER WSDOT 4-02. GRAVEL BASE SHALL BE INCREASED AS REQUIRED TO ACHIEVE A FIRM AND UNYIELDING SUBGRADE.

**5 GRAVEL SURFACING**  
NOT TO SCALE

**6 INLET PROTECTION**  
NOT TO SCALE

**DEMOLITION NOTES**

- DEMOLITION: IT IS THE INTENT UNDER THE WORK OF THIS CONTRACT TO INCLUDE, BUT NOT LIMITED TO, THE DEMOLITION OF ALL EXISTING BUILDINGS, PAVING, UTILITIES, BOLLARDS, GATES AND OTHER EXISTING SITE IMPROVEMENTS INCLUDING THE UNDERGROUND COMPONENTS AS CLARIFIED BY THIS DRAWING. IT IS THE CONTRACTOR'S RESPONSIBILITY TO FULLY REVIEW THE SITE CONDITIONS AND TO CORRELATE THESE OBSERVATIONS WITH THE PROJECT WORK AND INCLUDE ALL NECESSARY DEMOLITION, WHETHER SHOWN OR NOT, AND INCLUDE ALL SUCH COSTS IN THE SCOPE OF WORK.
- CLEARING: IT IS THE INTENT UNDER THE WORK OF THIS CONTRACT TO CONDUCT ALL CLEARING NECESSARY TO BE ABLE TO COMPLETE ALL THE WORK OF THIS PROJECT.
- CONTRACTOR SHALL LEGALLY DISPOSE ALL DEMOLISHED AND REMOVED MATERIALS OFF THE OWNER'S PROPERTY UNLESS INDICATED OTHERWISE.
- IT IS THE RESPONSIBILITY OF THE CONTRACTOR TO COMPLETELY COORDINATE UTILITY DEMOLITION WITH NEW CONSTRUCTION. CONTRACTOR SHALL ENSURE THAT ADEQUATE FIRE PROTECTION IN ACCORDANCE WITH THE FIRE MARSHALL'S REQUIREMENTS IS PROVIDED FOR THE NEW AND EXISTING BUILDINGS.
- DEMOLITION WORK MAY OCCUR OUTSIDE OF PROJECT LIMIT.

**CITY OF PUYALLUP CONSTRUCTION NOTES**

- ALL LIMITS OF CLEARING AND AREAS OF VEGETATION PRESERVATION AS PRESCRIBED ON THE PLANS SHALL BE CLEARLY FLAGGED IN THE FIELD AND OBSERVED DURING CONSTRUCTION.
- ALL REQUIRED SEDIMENTATION AND EROSION CONTROL FACILITIES MUST BE CONSTRUCTED AND IN OPERATION PRIOR TO ANY LAND CLEARING AND/OR OTHER CONSTRUCTION TO ENSURE THAT SEDIMENT LADEN WATER DOES NOT ENTER THE NATURAL DRAINAGE SYSTEM. THE CONTRACTOR SHALL SCHEDULE AN INSPECTION OF THE EROSION CONTROL FACILITIES PRIOR TO ANY LAND CLEARING AND/OR CONSTRUCTION. ALL EROSION AND SEDIMENT FACILITIES SHALL BE MAINTAINED IN A SATISFACTORY CONDITION AS DETERMINED BY THE CITY. UNTIL SUCH TIME THAT CLEARING AND/OR CONSTRUCTION IS COMPLETED AND THE POTENTIAL FOR ON-SITE EROSION HAS PASSED, THE IMPLEMENTATION, MAINTENANCE, REPLACEMENT, AND ADDITIONS TO THE EROSION AND SEDIMENTATION CONTROL SYSTEMS SHALL BE THE RESPONSIBILITY OF THE PERMITEE.
- THE EROSION AND SEDIMENTATION CONTROL SYSTEM FACILITIES DEPICTED ON THESE PLANS ARE INTENDED TO BE MINIMUM REQUIREMENTS TO MEET ANTICIPATED SITE CONDITIONS. AS CONSTRUCTION PROGRESSES AND UNEXPECTED OR SEASONAL CONDITIONS DICTATE, FACILITIES WILL BE NECESSARY TO ENSURE COMPLETE SILTATION CONTROL ON THE SITE. DURING THE COURSE OF CONSTRUCTION, IT SHALL BE THE OBLIGATION AND RESPONSIBILITY OF THE PERMITEE TO ADDRESS AND NEW CONDITIONS THAT MAY BE CREATED BY HIS ACTIVITIES AND TO PROVIDE ADDITIONAL FACILITIES, OVER AND ABOVE THE MINIMUM REQUIREMENTS, AS MAY BE NEEDED TO PROTECT ADJACENT PROPERTIES, SENSITIVE AREAS, NATURAL WATER COURSES, AND/OR STORM DRAINAGE SYSTEMS.
- APPROVAL OF THESE PLANS IS FOR GRADING TEMPORARY DRAINAGE, EROSION, AND SEDIMENTATION CONTROL ONLY. IT DOES NOT CONSTITUTE AND APPROVAL OF PERMANENT STORM DRAINAGE DESIGN, SIZE, OR LOCATION OF PIPES, RESTRICTORS, CHANNELS, OR RETENTION FACILITIES.
- ANY DISTURBED AREA WHICH HAS BEEN STRIPPED OF VEGETATION AND WHERE NO FURTHER WORKS IS ANTICIPATED FOR A PERIOD OF 30 DAYS OR MORE, MUST BE IMMEDIATELY STABILIZED WITH MULCHING, GRASS PLANTING, OR OTHER APPROVED EROSION CONTROL TREATMENT APPLICABLE TO THE TIME OF YEAR IN QUESTION. GRASS SEEDING ALONE WILL BE ACCEPTABLE ONLY DURING THE MONTHS OF APRIL THROUGH SEPTEMBER INCLUSIVE. SEEDING MAY PROCEED OUTSIDE THE SPECIFIED TIME PERIOD WHENEVER IT IS IN THE INTEREST OF THE PERMITEE BUT MUST BE AUGMENTED WITH MULCHING, NETTING, OR OTHER TREATMENT APPROVED BY THE CITY.
- IN CASE EROSION OR SEDIMENTATION OCCUR TO ADJACENT PROPERTIES, ALL CONSTRUCTION WORK WITHIN THE DEVELOPMENT THAT WILL FURTHER AGGRAVATE THE SITUATION MUST CEASE, AND THE OWNER/CONTRACTOR WILL IMMEDIATELY COMMENCE RESTORATION METHODS. RESTORATION ACTIVITY WILL CONTINUE UNTIL SUCH TIME AS THE AFFECTED PROPERTY OWNER IS SATISFIED.
- NO TEMPORARY OR PERMANENT STOCKPILING OF MATERIALS OR EQUIPMENT SHALL OCCUR WITHIN CRITICAL AREAS OR ASSOCIATED BUFFERS, OR THE CRITICAL ROOT ZONE FOR VEGETATION PROPOSED FOR RETENTION.

**APPROVED**

BY: CITY OF PUYALLUP  
ENGINEERING SERVICES

DATE:

NOTE: THIS APPROVAL IS VOID AFTER 1 YEAR FROM APPROVAL DATE. THE CITY WILL NOT BE RESPONSIBLE FOR ERRORS AND/OR OMISSIONS ON THESE PLANS. FIELD CONDITIONS MAY DICTATE CHANGES TO THESE PLANS AS DETERMINED BY THE ENGINEERING SERVICES MANAGER.

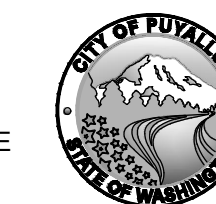

City of  
**PUYALLUP**



Know what's below.  
Call before you dig.



# ***Exhibit 2***

---

## **Inspection Logs**

**Larson River Road Storage**  
**Stormwater Pollution Prevention Plan**  
**Inspection and Maintenance Report Form**

To be completed every 7 days and within 24 hours of a rainfall event of 0.5 inches or more

Inspector: \_\_\_\_\_ Date: \_\_\_\_\_  
 Inspector's Qualifications: \_\_\_\_\_

Days since last rainfall: \_\_\_\_\_ Amount of last rainfall: \_\_\_\_\_ inches

**Stabilization Measures**

Drainage Area	Date Since Last Disturbance	Date of Next Disturbance	Stabilized (yes/No)	Stabilized With	Condition

Stabilization required: \_\_\_\_\_

To be performed by: \_\_\_\_\_ On or before: \_\_\_\_\_

**Larson River Road Storage**  
**Stormwater Pollution Prevention Plan**  
**Inspection and Maintenance Report Form**

Site Entrance:

Date:

**Temporary Construction Entrance**

Drainage Area Perimeter	Does Rock Pad Adequately Remove Mud from Vehicle Wheels?	Is Rock Pad Clogged with Mud?	Have Quarry Spalls Been Moved to the Roadway?

Maintenance required for temporary construction entrances:

To be performed by: \_\_\_\_\_ On or before: \_\_\_\_\_



**Larson River Road Storage**  
**Stormwater Pollution Prevention Plan**  
**Inspection and Maintenance Report Form**

Perimeter Structural Controls:

Date:

**Silt Fence**

Drainage Area Perimeter	Has Silt Reached 1/3 of Fence Height?	Is Fence Properly Secured?	Is There Evidence of Washout or Overtopping?

Maintenance required for silt fence and straw bales:

To be performed by: \_\_\_\_\_ On or before: \_\_\_\_\_

**Larson River Road Storage**  
**Stormwater Pollution Prevention Plan**  
**Inspection and Maintenance Report Form**

Inlet Protection:

Date:

**Storm Drain Barriers**

Inlet	Has Silt Reached 1/3 of Barrier Height?	Is Barrier Properly Secured?	Is There Evidence of Washout or Overtopping?

Maintenance required for storm drain barriers:

To be performed by: \_\_\_\_\_ On or before: \_\_\_\_\_

**Larson River Road Storage**  
**Stormwater Pollution Prevention Plan**  
**Inspection and Maintenance Report Form**

Changes required to the pollution prevention plan:

Reasons for changes:

I certify under penalty of law that this document and all attachments were prepared under my direction or supervision in accordance with a system designed to assure that qualified personnel properly gathered and evaluated the information submitted. Based on my inquiry of the person or persons who manage the system, or those persons directly responsible for gathering the information, the information submitted is, to the best of my knowledge and belief, true, accurate, and complete. I am aware that there are significant penalties for submitting false information, including the possibility of fine and imprisonment for knowing violations.

Signature: \_\_\_\_\_ Date: \_\_\_\_\_

# Exhibit 3

---

## Best Management Practices (BMPs)

- BMP C105..... Stabilized Construction Entrance
- BMP C120..... Temporary and Permanent Seeding
- BMP C121..... Mulching
- BMP C123..... Plastic Covering
- BMP C140..... Dust Control
- BMP C151..... Concrete Handling
- BMP C152..... Sawcutting and Surface Pollution Prevention
- BMP C160..... Certified Erosion and Sediment Control Lead
- BMP C220..... Storm Drain Inlet Protection
- BMP C233..... Silt Fence



## **BMP C105: Stabilized Construction Entrance**

**Purpose** Construction entrances are stabilized to reduce the amount of sediment transported onto paved roads by vehicles or equipment by constructing a stabilized pad of quarry spalls at entrances to construction sites.

**Conditions of Use** Construction entrances shall be stabilized wherever traffic will be leaving a construction site and traveling on paved roads or other paved areas within 1,000 feet of the site.

On large commercial, highway, and road projects, the designer should include enough extra materials in the contract to allow for additional stabilized entrances not shown in the initial Construction SWPPP. It is difficult to determine exactly where access to these projects will take place; additional materials will enable the contractor to install them where needed.

### **Design and Installation Specifications**

- See Figure 4.2 for details. Note: the 100' minimum length of the entrance shall be reduced to the maximum practicable size when the size or configuration of the site does not allow the full length (100').
- A separation geotextile shall be placed under the spalls to prevent fine sediment from pumping up into the rock pad. The geotextile shall meet the following standards:

Grab Tensile Strength (ASTM D4751)	200 psi min.
Grab Tensile Elongation (ASTM D4632)	30% max.
Mullen Burst Strength (ASTM D3786-80a)	400 psi min.
AOS (ASTM D4751)	20-45 (U.S. standard sieve size)

- Consider early installation of the first lift of asphalt in areas that will paved; this can be used as a stabilized entrance. Also consider the installation of excess concrete as a stabilized entrance. During large concrete pours, excess concrete is often available for this purpose.
- Hog fuel (wood-based mulch) may be substituted for or combined with quarry spalls in areas that will not be used for permanent roads. Hog fuel is generally less effective at stabilizing construction entrances and should be used only at sites where the amount of traffic is very limited. Hog fuel is not recommended for entrance stabilization in urban areas. The effectiveness of hog fuel is highly variable and it generally requires more maintenance than quarry spalls. The inspector may at any time require the use of quarry spalls if the hog fuel is not preventing sediment from being tracked onto pavement or if the hog fuel is being carried onto pavement. Hog fuel is prohibited in permanent roadbeds because organics in the subgrade soils cause degradation of the subgrade support over time.
- Fencing (see BMPs C103 and C104) shall be installed as necessary to restrict traffic to the construction entrance.

**Maintenance Standards**

- Whenever possible, the entrance shall be constructed on a firm, compacted subgrade. This can substantially increase the effectiveness of the pad and reduce the need for maintenance.
- Quarry spalls (or hog fuel) shall be added if the pad is no longer in accordance with the specifications.
- If the entrance is not preventing sediment from being tracked onto pavement, then alternative measures to keep the streets free of sediment shall be used. This may include street sweeping, an increase in the dimensions of the entrance, or the installation of a wheel wash.
- Any sediment that is tracked onto pavement shall be removed by shoveling or street sweeping. The sediment collected by sweeping shall be removed or stabilized on site. The pavement shall not be cleaned by washing down the street, except when sweeping is ineffective and there is a threat to public safety. If it is necessary to wash the streets, the construction of a small sump shall be considered. The sediment would then be washed into the sump where it can be controlled.
- Any quarry spalls that are loosened from the pad, which end up on the roadway shall be removed immediately.
- If vehicles are entering or exiting the site at points other than the construction entrance(s), fencing (see BMPs C103 and C104) shall be installed to control traffic.
- Upon project completion and site stabilization, all construction accesses intended as permanent access for maintenance shall be permanently stabilized.

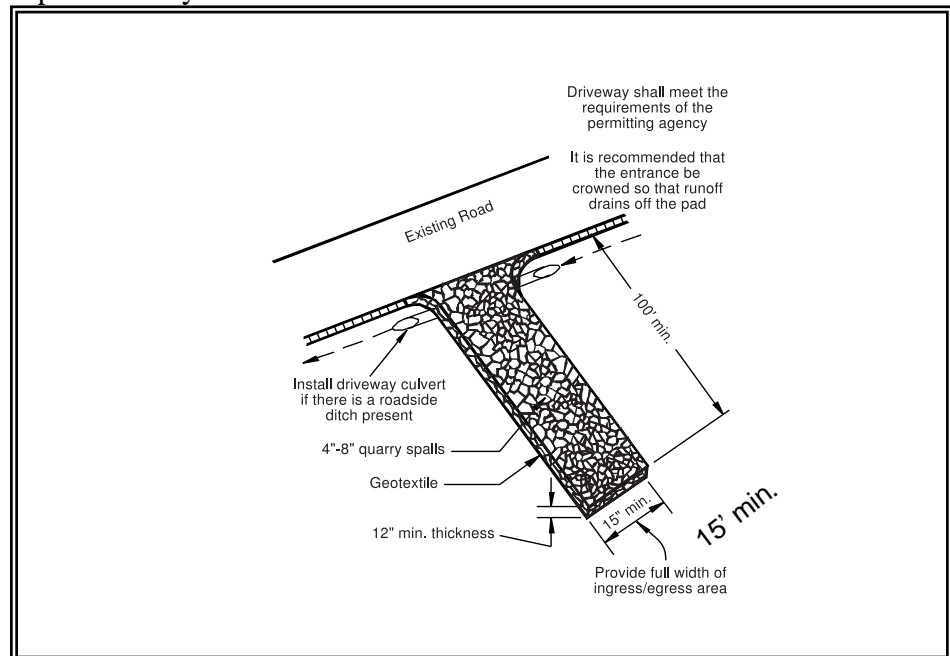

**Figure 4.2 – Stabilized Construction Entrance**

## **BMP C120: Temporary and Permanent Seeding**

### ***Purpose***

Seeding is intended to reduce erosion by stabilizing exposed soils. A well-established vegetative cover is one of the most effective methods of reducing erosion.

### ***Conditions of Use***

- Seeding may be used throughout the project on disturbed areas that have reached final grade or that will remain unworked for more than 30 days.
- Channels that will be vegetated should be installed before major earthwork and hydroseeded with a Bonded Fiber Matrix. The vegetation should be well established (i.e., 75 percent cover) before water is allowed to flow in the ditch. With channels that will have high flows, erosion control blankets should be installed over the hydroseed. If vegetation cannot be established from seed before water is allowed in the ditch, sod should be installed in the bottom of the ditch over hydromulch and blankets.
- Retention/detention ponds should be seeded as required.
- Mulch is required at all times because it protects seeds from heat, moisture loss, and transport due to runoff.
- All disturbed areas shall be reviewed in late August to early September and all seeding should be completed by the end of September. Otherwise, vegetation will not establish itself enough to provide more than average protection.
- At final site stabilization, all disturbed areas not otherwise vegetated or stabilized shall be seeded and mulched. Final stabilization means the completion of all soil disturbing activities at the site and the establishment of a permanent vegetative cover, or equivalent permanent stabilization measures (such as pavement, riprap, gabions or geotextiles) which will prevent erosion.

### ***Design and Installation Specifications***

- Seeding should be done during those seasons most conducive to growth and will vary with the climate conditions of the region. Local experience should be used to determine the appropriate seeding periods.
- The optimum seeding windows for western Washington are April 1 through June 30 and September 1 through October 1. Seeding that occurs between July 1 and August 30 will require irrigation until 75 percent grass cover is established. Seeding that occurs between October 1 and March 30 will require a mulch or plastic cover until 75 percent grass cover is established.
- To prevent seed from being washed away, confirm that all required surface water control measures have been installed.

- The seedbed should be firm and rough. All soil should be roughened no matter what the slope. If compaction is required for engineering purposes, slopes must be track walked before seeding. Backblading or smoothing of slopes greater than 4:1 is not allowed if they are to be seeded.
- New and more effective restoration-based landscape practices rely on deeper incorporation than that provided by a simple single-pass rototilling treatment. Wherever practical the subgrade should be initially ripped to improve long-term permeability, infiltration, and water inflow qualities. At a minimum, permanent areas shall use soil amendments to achieve organic matter and permeability performance defined in engineered soil/landscape systems. For systems that are deeper than 8 inches the rototilling process should be done in multiple lifts, or the prepared soil system shall be prepared properly and then placed to achieve the specified depth.
- Organic matter is the most appropriate form of “fertilizer” because it provides nutrients (including nitrogen, phosphorus, and potassium) in the least water-soluble form. A natural system typically releases 2-10 percent of its nutrients annually. Chemical fertilizers have since been formulated to simulate what organic matter does naturally.
- In general, 10-4-6 N-P-K (nitrogen-phosphorus-potassium) fertilizer can be used at a rate of 90 pounds per acre. Slow-release fertilizers should always be used because they are more efficient and have fewer environmental impacts. It is recommended that areas being seeded for final landscaping conduct soil tests to determine the exact type and quantity of fertilizer needed. This will prevent the over-application of fertilizer. Fertilizer should not be added to the hydromulch machine and agitated more than 20 minutes before it is to be used. If agitated too much, the slow-release coating is destroyed.
- There are numerous products available on the market that take the place of chemical fertilizers. These include several with seaweed extracts that are beneficial to soil microbes and organisms. If 100 percent cottonseed meal is used as the mulch in hydroseed, chemical fertilizer may not be necessary. Cottonseed meal is a good source of long-term, slow-release, available nitrogen.
- Hydroseed applications shall include a minimum of 1,500 pounds per acre of mulch with 3 percent tackifier. Mulch may be made up of 100 percent: cottonseed meal; fibers made of wood, recycled cellulose, hemp, and kenaf; compost; or blends of these. Tackifier shall be plant-based, such as guar or alpha plantago, or chemical-based such as polyacrylamide or polymers. Any mulch or tackifier product used shall be installed per manufacturer’s instructions. Generally, mulches come in 40-50 pound bags. Seed and fertilizer are added at time of application.



- Mulch is always required for seeding. Mulch can be applied on top of the seed or simultaneously by hydroseeding.
- On steep slopes, Bonded Fiber Matrix (BFM) or Mechanically Bonded Fiber Matrix (MBFM) products should be used. BFM/MBFM products are applied at a minimum rate of 3,000 pounds per acre of mulch with approximately 10 percent tackifier. Application is made so that a minimum of 95 percent soil coverage is achieved. Numerous products are available commercially and should be installed per manufacturer's instructions. Most products require 24-36 hours to cure before a rainfall and cannot be installed on wet or saturated soils. Generally, these products come in 40-50 pound bags and include all necessary ingredients except for seed and fertilizer.

BFMs and MBFMs have some advantages over blankets:

- No surface preparation required;
- Can be installed via helicopter in remote areas;
- On slopes steeper than 2.5:1, blanket installers may need to be roped and harnessed for safety;
- They are at least \$1,000 per acre cheaper installed.

In most cases, the shear strength of blankets is not a factor when used on slopes, only when used in channels. BFMs and MBFMs are good alternatives to blankets in most situations where vegetation establishment is the goal.

- When installing seed via hydroseeding operations, only about 1/3 of the seed actually ends up in contact with the soil surface. This reduces the ability to establish a good stand of grass quickly. One way to overcome this is to increase seed quantities by up to 50 percent.
- Vegetation establishment can also be enhanced by dividing the hydromulch operation into two phases:
  1. Phase 1- Install all seed and fertilizer with 25-30 percent mulch and tackifier onto soil in the first lift;
  2. Phase 2- Install the rest of the mulch and tackifier over the first lift.

An alternative is to install the mulch, seed, fertilizer, and tackifier in one lift. Then, spread or blow straw over the top of the hydromulch at a rate of about 800-1000 pounds per acre. Hold straw in place with a standard tackifier. Both of these approaches will increase cost moderately but will greatly improve and enhance vegetative establishment. The increased cost may be offset by the reduced need for:

1. Irrigation
2. Reapplication of mulch
3. Repair of failed slope surfaces

This technique works with standard hydromulch (1,500 pounds per acre minimum) and BFM/MBFMs (3,000 pounds per acre minimum).

- Areas to be permanently landscaped shall provide a healthy topsoil that reduces the need for fertilizers, improves overall topsoil quality, provides for better vegetal health and vitality, improves hydrologic characteristics, and reduces the need for irrigation. This can be accomplished in a number of ways:

Recent research has shown that the best method to improve till soils is to amend these soils with compost. The optimum mixture is approximately two parts soil to one part compost. This equates to 4 inches of compost mixed to a depth of 12 inches in till soils. Increasing the concentration of compost beyond this level can have negative effects on vegetal health, while decreasing the concentrations can reduce the benefits of amended soils. Please note: The compost should meet specifications for Grade A quality compost in Ecology Publication 94-038.

Other soils, such as gravel or cobble outwash soils, may require different approaches. Organics and fines easily migrate through the loose structure of these soils. Therefore, the importation of at least 6 inches of quality topsoil, underlain by some type of filter fabric to prevent the migration of fines, may be more appropriate for these soils.

Areas that already have good topsoil, such as undisturbed areas, do not require soil amendments.

- Areas that will be seeded only and not landscaped may need compost or meal-based mulch included in the hydroseed in order to establish vegetation. Native topsoil should be re-installed on the disturbed soil surface before application.
- Seed that is installed as a temporary measure may be installed by hand if it will be covered by straw, mulch, or topsoil. Seed that is installed as a permanent measure may be installed by hand on small areas (usually less than 1 acre) that will be covered with mulch, topsoil, or erosion blankets. The seed mixes listed below include recommended mixes for both temporary and permanent seeding. These mixes, with the exception of the wetland mix, shall be applied at a rate of 120 pounds per acre. This rate can be reduced if soil amendments or slow-release fertilizers are used. Local suppliers or the local conservation district should be consulted for their recommendations because the appropriate mix depends on a variety of factors, including location, exposure, soil type, slope, and expected foot traffic. Alternative seed mixes approved by the local authority may be used.

Table 4.1 represents the standard mix for those areas where just a temporary vegetative cover is required.

<b>Table 4.1 Temporary Erosion Control Seed Mix</b>			
	<b>% Weight</b>	<b>% Purity</b>	<b>% Germination</b>
Chewings or annual blue grass <i>Festuca rubra var. commutata</i> or <i>Poa anna</i>	40	98	90
Perennial rye - <i>Lolium perenne</i>	50	98	90
Redtop or colonial bentgrass <i>Agrostis alba</i> or <i>Agrostis tenuis</i>	5	92	85
White dutch clover <i>Trifolium repens</i>	5	98	90

Table 4.2 provides just one recommended possibility for landscaping seed.

<b>Table 4.2 Landscaping Seed Mix</b>			
	<b>% Weight</b>	<b>% Purity</b>	<b>% Germination</b>
Perennial rye blend <i>Lolium perenne</i>	70	98	90
Chewings and red fescue blend <i>Festuca rubra var. commutata</i> or <i>Festuca rubra</i>	30	98	90

This turf seed mix in Table 4.3 is for dry situations where there is no need for much water. The advantage is that this mix requires very little maintenance.

<b>Table 4.3 Low-Growing Turf Seed Mix</b>			
	<b>% Weight</b>	<b>% Purity</b>	<b>% Germination</b>
Dwarf tall fescue (several varieties) <i>Festuca arundinacea var.</i>	45	98	90
Dwarf perennial rye (Barclay) <i>Lolium perenne var. barclay</i>	30	98	90
Red fescue <i>Festuca rubra</i>	20	98	90
Colonial bentgrass <i>Agrostis tenuis</i>	5	98	90

Table 4.4 presents a mix recommended for bioswales and other intermittently wet areas.

<b>Table 4.4 Bioswale Seed Mix*</b>			
	<b>% Weight</b>	<b>% Purity</b>	<b>% Germination</b>
Tall or meadow fescue <i>Festuca arundinacea</i> or <i>Festuca elatior</i>	75-80	98	90
Seaside/Creeping bentgrass <i>Agrostis palustris</i>	10-15	92	85
Redtop bentgrass <i>Agrostis alba</i> or <i>Agrostis gigantea</i>	5-10	90	80

\* Modified Briargreen, Inc. Hydroseeding Guide Wetlands Seed Mix

The seed mix shown in Table 4.5 is a recommended low-growing, relatively non-invasive seed mix appropriate for very wet areas that are not regulated wetlands. Other mixes may be appropriate, depending on the soil type and hydrology of the area. Recent research suggests that bentgrass (*agrostis* sp.) should be emphasized in wet-area seed mixes. Apply this mixture at a rate of 60 pounds per acre.

<b>Table 4.5 Wet Area Seed Mix*</b>			
	<b>% Weight</b>	<b>% Purity</b>	<b>% Germination</b>
Tall or meadow fescue <i>Festuca arundinacea</i> or <i>Festuca elatior</i>	60-70	98	90
Seaside/Creeping bentgrass <i>Agrostis palustris</i>	10-15	98	85
Meadow foxtail <i>Alepcurus pratensis</i>	10-15	90	80
Alsike clover <i>Trifolium hybridum</i>	1-6	98	90
Redtop bentgrass <i>Agrostis alba</i>	1-6	92	85

\* Modified Briargreen, Inc. Hydroseeding Guide Wetlands Seed Mix

The meadow seed mix in Table 4.6 is recommended for areas that will be maintained infrequently or not at all and where colonization by native plants is desirable. Likely applications include rural road and utility right-of-way. Seeding should take place in September or very early October in order to obtain adequate establishment prior to the winter months. The appropriateness of clover in the mix may need to be considered, as this can be a fairly invasive species. If the soil is amended, the addition of clover may not be necessary.

<b>Table 4.6 Meadow Seed Mix</b>			
	<b>% Weight</b>	<b>% Purity</b>	<b>% Germination</b>
Redtop or Oregon bentgrass <i>Agrostis alba</i> or <i>Agrostis oregonensis</i>	20	92	85
Red fescue <i>Festuca rubra</i>	70	98	90
White dutch clover <i>Trifolium repens</i>	10	98	90

**Maintenance Standards**

- Any seeded areas that fail to establish at least 80 percent cover (100 percent cover for areas that receive sheet or concentrated flows) shall be reseeded. If reseeding is ineffective, an alternate method, such as sodding, mulching, or nets/blankets, shall be used. If winter weather prevents adequate grass growth, this time limit may be relaxed at the discretion of the local authority when sensitive areas would otherwise be protected.

- After adequate cover is achieved, any areas that experience erosion shall be reseeded and protected by mulch. If the erosion problem is drainage related, the problem shall be fixed and the eroded area reseeded and protected by mulch.
- Seeded areas shall be supplied with adequate moisture, but not watered to the extent that it causes runoff.

## **BMP C121: Mulching**

### ***Purpose***

The purpose of mulching soils is to provide immediate temporary protection from erosion. Mulch also enhances plant establishment by conserving moisture, holding fertilizer, seed, and topsoil in place, and moderating soil temperatures. There is an enormous variety of mulches that can be used. Only the most common types are discussed in this section.

### ***Conditions of Use***

As a temporary cover measure, mulch should be used:

- On disturbed areas that require cover measures for less than 30 days.
- As a cover for seed during the wet season and during the hot summer months.
- During the wet season on slopes steeper than 3H:1V with more than 10 feet of vertical relief.
- Mulch may be applied at any time of the year and must be refreshed periodically.

### ***Design and Installation Specifications***

For mulch materials, application rates, and specifications, see Table 4.7. Note: Thicknesses may be increased for disturbed areas in or near sensitive areas or other areas highly susceptible to erosion.

Mulch used within the ordinary high-water mark of surface waters should be selected to minimize potential flotation of organic matter. Composted organic materials have higher specific gravities (densities) than straw, wood, or chipped material.

### ***Maintenance Standards***

- The thickness of the cover must be maintained.
- Any areas that experience erosion shall be remulched and/or protected with a net or blanket. If the erosion problem is drainage related, then the problem shall be fixed and the eroded area remulched.

**Table 4.7  
Mulch Standards and Guidelines**

<b>Mulch Material</b>	<b>Quality Standards</b>	<b>Application Rates</b>	<b>Remarks</b>
Straw	Air-dried; free from undesirable seed and coarse material.	2"-3" thick; 5 bales per 1000 sf or 2-3 tons per acre	Cost-effective protection when applied with adequate thickness. Hand-application generally requires greater thickness than blown straw. The thickness of straw may be reduced by half when used in conjunction with seeding. In windy areas straw must be held in place by crimping, using a tackifier, or covering with netting. Blown straw always has to be held in place with a tackifier as even light winds will blow it away. Straw, however, has several deficiencies that should be considered when selecting mulch materials. It often introduces and/or encourages the propagation of weed species and it has no significant long-term benefits. Straw should be used only if mulches with long-term benefits are unavailable locally. It should also not be used within the ordinary high-water elevation of surface waters (due to flotation).
Hydromulch	No growth inhibiting factors.	Approx. 25-30 lbs per 1000 sf or 1500 - 2000 lbs per acre	Shall be applied with hydromulcher. Shall not be used without seed and tackifier unless the application rate is at least doubled. Fibers longer than about ¾-1 inch clog hydromulch equipment. Fibers should be kept to less than ¾ inch.
Composted Mulch and Compost	No visible water or dust during handling. Must be purchased from supplier with Solid Waste Handling Permit (unless exempt).	2" thick min.; approx. 100 tons per acre (approx. 800 lbs per yard)	More effective control can be obtained by increasing thickness to 3". Excellent mulch for protecting final grades until landscaping because it can be directly seeded or tilled into soil as an amendment. Composted mulch has a coarser size gradation than compost. It is more stable and practical to use in wet areas and during rainy weather conditions.
Chipped Site Vegetation	Average size shall be several inches. Gradations from fines to 6 inches in length for texture, variation, and interlocking properties.	2" minimum thickness	This is a cost-effective way to dispose of debris from clearing and grubbing, and it eliminates the problems associated with burning. Generally, it should not be used on slopes above approx. 10% because of its tendency to be transported by runoff. It is not recommended within 200 feet of surface waters. If seeding is expected shortly after mulch, the decomposition of the chipped vegetation may tie up nutrients important to grass establishment.
Wood-based Mulch	No visible water or dust during handling. Must be purchased from a supplier with a Solid Waste Handling Permit or one exempt from solid waste regulations.	2" thick; approx. 100 tons per acre (approx. 800 lbs. per cubic yard)	This material is often called "hog or hogged fuel." It is usable as a material for Stabilized Construction Entrances (BMP C105) and as a mulch. The use of mulch ultimately improves the organic matter in the soil. Special caution is advised regarding the source and composition of wood-based mulches. Its preparation typically does not provide any weed seed control, so evidence of residual vegetation in its composition or known inclusion of weed plants or seeds should be monitored and prevented (or minimized).

## **BMP C123: Plastic Covering**

### ***Purpose***

Plastic covering provides immediate, short-term erosion protection to slopes and disturbed areas.

### ***Conditions of Use***

- Plastic covering may be used on disturbed areas that require cover measures for less than 30 days, except as stated below.
- Plastic is particularly useful for protecting cut and fill slopes and stockpiles. Note: The relatively rapid breakdown of most polyethylene sheeting makes it unsuitable for long-term (greater than six months) applications.
- Clear plastic sheeting can be used over newly-seeded areas to create a greenhouse effect and encourage grass growth if the hydroseed was installed too late in the season to establish 75 percent grass cover, or if the wet season started earlier than normal. Clear plastic should not be used for this purpose during the summer months because the resulting high temperatures can kill the grass.
- Due to rapid runoff caused by plastic sheeting, this method shall not be used upslope of areas that might be adversely impacted by concentrated runoff. Such areas include steep and/or unstable slopes.
- While plastic is inexpensive to purchase, the added cost of installation, maintenance, removal, and disposal make this an expensive material, up to \$1.50-2.00 per square yard.
- Whenever plastic is used to protect slopes, water collection measures must be installed at the base of the slope. These measures include plastic-covered berms, channels, and pipes used to convey clean rainwater away from bare soil and disturbed areas. At no time is clean runoff from a plastic covered slope to be mixed with dirty runoff from a project.
- Other uses for plastic include:
  1. Temporary ditch liner;
  2. Pond liner in temporary sediment pond;
  3. Liner for bermed temporary fuel storage area if plastic is not reactive to the type of fuel being stored;
  4. Emergency slope protection during heavy rains; and,
  5. Temporary drainpipe (“elephant trunk”) used to direct water.



***Design and  
Installation  
Specifications***

- Plastic slope cover must be installed as follows:
  1. Run plastic up and down slope, not across slope;
  2. Plastic may be installed perpendicular to a slope if the slope length is less than 10 feet;
  3. Minimum of 8-inch overlap at seams;
  4. On long or wide slopes, or slopes subject to wind, all seams should be taped;
  5. Place plastic into a small (12-inch wide by 6-inch deep) slot trench at the top of the slope and backfill with soil to keep water from flowing underneath;
  6. Place sand filled burlap or geotextile bags every 3 to 6 feet along seams and pound a wooden stake through each to hold them in place;
  7. Inspect plastic for rips, tears, and open seams regularly and repair immediately. This prevents high velocity runoff from contacting bare soil which causes extreme erosion;
  8. Sandbags may be lowered into place tied to ropes. However, all sandbags must be staked in place.
- Plastic sheeting shall have a minimum thickness of 0.06 millimeters.
- If erosion at the toe of a slope is likely, a gravel berm, riprap, or other suitable protection shall be installed at the toe of the slope in order to reduce the velocity of runoff.

***Maintenance  
Standards***

- Torn sheets must be replaced and open seams repaired.
- If the plastic begins to deteriorate due to ultraviolet radiation, it must be completely removed and replaced.
- When the plastic is no longer needed, it shall be completely removed.
- Dispose of old tires appropriately.

## **BMP C140: Dust Control**

- Purpose*** Dust control prevents wind transport of dust from disturbed soil surfaces onto roadways, drainage ways, and surface waters.
- Conditions of Use***
- In areas (including roadways) subject to surface and air movement of dust where on-site and off-site impacts to roadways, drainage ways, or surface waters are likely.
- Design and Installation Specifications***
- Vegetate or mulch areas that will not receive vehicle traffic. In areas where planting, mulching, or paving is impractical, apply gravel or landscaping rock.
  - Limit dust generation by clearing only those areas where immediate activity will take place, leaving the remaining area(s) in the original condition, if stable. Maintain the original ground cover as long as practical.
  - Construct natural or artificial windbreaks or windscreens. These may be designed as enclosures for small dust sources.
  - Sprinkle the site with water until surface is wet. Repeat as needed. To prevent carryout of mud onto street, refer to Stabilized Construction Entrance (BMP C105).
  - Irrigation water can be used for dust control. Irrigation systems should be installed as a first step on sites where dust control is a concern.
  - Spray exposed soil areas with a dust palliative, following the manufacturer's instructions and cautions regarding handling and application. Used oil is prohibited from use as a dust suppressant. Local governments may approve other dust palliatives such as calcium chloride or PAM.
  - PAM (BMP C126) added to water at a rate of 0.5 lbs. per 1,000 gallons of water per acre and applied from a water truck is more effective than water alone. This is due to the increased infiltration of water into the soil and reduced evaporation. In addition, small soil particles are bonded together and are not as easily transported by wind. Adding PAM may actually reduce the quantity of water needed for dust control, especially in eastern Washington. Since the wholesale cost of PAM is about \$ 4.00 per pound, this is an extremely cost-effective dust control method.
- Techniques that can be used for unpaved roads and lots include:
- Lower speed limits. High vehicle speed increases the amount of dust stirred up from unpaved roads and lots.
  - Upgrade the road surface strength by improving particle size, shape, and mineral types that make up the surface and base materials.

- Add surface gravel to reduce the source of dust emission. Limit the amount of fine particles (those smaller than .075 mm) to 10 to 20 percent.
- Use geotextile fabrics to increase the strength of new roads or roads undergoing reconstruction.
- Encourage the use of alternate, paved routes, if available.
- Restrict use by tracked vehicles and heavy trucks to prevent damage to road surface and base.
- Apply chemical dust suppressants using the admix method, blending the product with the top few inches of surface material. Suppressants may also be applied as surface treatments.
- Pave unpaved permanent roads and other trafficked areas.
- Use vacuum street sweepers.
- Remove mud and other dirt promptly so it does not dry and then turn into dust.
- Limit dust-causing work on windy days.
- Contact your local Air Pollution Control Authority for guidance and training on other dust control measures. Compliance with the local Air Pollution Control Authority constitutes compliance with this BMP.

***Maintenance  
Standards***

Respray area as necessary to keep dust to a minimum.

## **BMP C151: Concrete Handling**

***Purpose*** Concrete work can generate process water and slurry that contain fine particles and high pH, both of which can violate water quality standards in the receiving water. This BMP is intended to minimize and eliminate concrete process water and slurry from entering waters of the state.

***Conditions of Use*** Any time concrete is used, these management practices shall be utilized. Concrete construction projects include, but are not limited to, the following:

- Curbs
- Sidewalks
- Roads
- Bridges
- Foundations
- Floors
- Runways
- Concrete truck chutes, pumps, and internals shall be washed out only into formed areas awaiting installation of concrete or asphalt.
- Unused concrete remaining in the truck and pump shall be returned to the originating batch plant for recycling.
- Hand tools including, but not limited to, screeds, shovels, rakes, floats, and trowels shall be washed off only into formed areas awaiting installation of concrete or asphalt.
- Equipment that cannot be easily moved, such as concrete pavers, shall only be washed in areas that do not directly drain to natural or constructed stormwater conveyances.
- Washdown from areas such as concrete aggregate driveways shall not drain directly to natural or constructed stormwater conveyances.
- When no formed areas are available, washwater and leftover product shall be contained in a lined container. Contained concrete shall be disposed of in a manner that does not violate groundwater or surface water quality standards.

***Maintenance Standards*** Containers shall be checked for holes in the liner daily during concrete pours and repaired the same day.

## **BMP C152: Sawcutting and Surfacing Pollution Prevention**

<i><b>Purpose</b></i>	Sawcutting and surfacing operations generate slurry and process water that contains fine particles and high pH (concrete cutting), both of which can violate the water quality standards in the receiving water. This BMP is intended to minimize and eliminate process water and slurry from entering waters of the State.
<i><b>Conditions of Use</b></i>	Anytime sawcutting or surfacing operations take place, these management practices shall be utilized. Sawcutting and surfacing operations include, but are not limited to, the following: <ul style="list-style-type: none"><li>• Sawing</li><li>• Coring</li><li>• Grinding</li><li>• Roughening</li><li>• Hydro-demolition</li><li>• Bridge and road surfacing</li></ul>
<i><b>Design and Installation Specifications</b></i>	<ul style="list-style-type: none"><li>• Slurry and cuttings shall be vacuumed during cutting and surfacing operations.</li><li>• Slurry and cuttings shall not remain on permanent concrete or asphalt pavement overnight.</li><li>• Slurry and cuttings shall not drain to any natural or constructed drainage conveyance.</li><li>• Collected slurry and cuttings shall be disposed of in a manner that does not violate groundwater or surface water quality standards.</li><li>• Process water that is generated during hydro-demolition, surface roughening or similar operations shall not drain to any natural or constructed drainage conveyance and shall be disposed of in a manner that does not violate groundwater or surface water quality standards.</li><li>• Cleaning waste material and demolition debris shall be handled and disposed of in a manner that does not cause contamination of water. If the area is swept with a pick-up sweeper, the material must be hauled out of the area to an appropriate disposal site.</li></ul>
<i><b>Maintenance Standards</b></i>	Continually monitor operations to determine whether slurry, cuttings, or process water could enter waters of the state. If inspections show that a violation of water quality standards could occur, stop operations and immediately implement preventive measures such as berms, barriers, secondary containment, and vacuum trucks.

## **BMP C160: Certified Erosion and Sediment Control Lead**

**Purpose** The project proponent designates at least one person as the responsible representative in charge of erosion and sediment control (ESC), and water quality protection. The designated person shall be the Certified Erosion and Sediment Control Lead (CESCL) who is responsible for ensuring compliance with all local, state, and federal erosion and sediment control and water quality requirements.

**Conditions of Use** A CESCL shall be made available on projects one acre or larger that discharge stormwater to surface waters of the state

- The CESCL shall:
  - Have a current certificate proving attendance in an erosion and sediment control training course that meets the minimum ESC training and certification requirements established by Ecology (see details below).

Ecology will maintain a list of ESC training and certification providers at: [www.ecy.wa.gov/programs/wq/stormwater](http://www.ecy.wa.gov/programs/wq/stormwater).

### **OR**

- Be a Certified Professional in Erosion and Sediment Control (CPESC); for additional information go to: [www.cpesc.net](http://www.cpesc.net)

### **Specifications**

- Certification shall remain valid for three years.
- The CESCL shall have authority to act on behalf of the contractor or developer and shall be available, on call, 24 hours per day throughout the period of construction.
- The Construction SWPPP shall include the name, telephone number, fax number, and address of the designated CESCL.
- A CESCL may provide inspection and compliance services for multiple construction projects in the same geographic region.

Duties and responsibilities of the CESCL shall include, but are not limited to the following:

- Maintaining permit file on site at all times which includes the SWPPP and any associated permits and plans.
- Directing BMP installation, inspection, maintenance, modification, and removal.
- Updating all project drawings and the Construction SWPPP with changes made.

- Keeping daily logs, and inspection reports. Inspection reports should include:
  - Inspection date/time.
  - Weather information; general conditions during inspection and approximate amount of precipitation since the last inspection.
  - A summary or list of all BMPs implemented, including observations of all erosion/sediment control structures or practices. The following shall be noted:
    - 1) Locations of BMPs inspected,
    - 2) Locations of BMPs that need maintenance,
    - 3) Locations of BMPs that failed to operate as designed or intended, and
    - 4) Locations of where additional or different BMPs are required.
  - Visual monitoring results, including a description of discharged stormwater. The presence of suspended sediment, turbid water, discoloration, and oil sheen shall be noted, as applicable.
  - Any water quality monitoring performed during inspection.
  - General comments and notes, including a brief description of any BMP repairs, maintenance or installations made as a result of the inspection.
- Facilitate, participate in, and take corrective actions resulting from inspections performed by outside agencies or the owner.

## Minimum Requirements for ESC Training and Certification Courses

### General Requirements

1. The course shall teach the construction stormwater pollution prevention guidance provided in the most recent version of:
  - a. The Washington State Dept. of Ecology Stormwater Management Manual for Western Washington,
  - b. Other equivalent stormwater management manuals approved by Ecology.
2. Upon completion of course, each attendee shall receive documentation of certification, including, at a minimum, a wallet-sized card that certifies completion of the course. Certification shall remain valid for three years. Recertification may be obtained by completing the 8-hour refresher course or by taking the initial 16-hour training course again.
3. The initial certification course shall be a minimum of 16 hours (with a reasonable time allowance for lunch, breaks, and travel to and from field) and include a field element and test.
  - a. The field element must familiarize students with the proper installation, maintenance and inspection of common erosion and sediment control BMPs including, but not limited to, blankets, check dams, silt fence, straw mulch, plastic, and seeding.
  - b. The test shall be open book and a passing score is not required for certification. Upon completion of the test, the correct answers shall be provided and discussed.
4. The refresher course shall be a minimum of 8 hours and include a test.
  - a. The refresher course shall include:
    - i. Applicable updates to the Stormwater Management Manual that is used to teach the course, including new or updated BMPs; and
    - ii. Applicable changes to the NPDES General Permit for Construction Activities.
  - b. The refresher course test shall be open book and a passing score is not required for certification. Upon completion of the test, the correct answers shall be provided and discussed.
  - c. The refresher course may be taught using an alternative format (e.g. internet, CD ROM, etc.) if the module is approved by Ecology.

### Required Course Elements

1. Erosion and Sedimentation Impacts
  - a. Examples/Case studies



2. Erosion and Sedimentation Processes
  - a. Definitions
  - b. Types of erosion
  - c. Sedimentation
    - i. Basic settling concepts
    - ii. Problems with clays/turbidity
3. Factors Influencing Erosion Potential
  - a. Soil
  - b. Vegetation
  - c. Topography
  - d. Climate
4. Regulatory Requirements
  - a. NPDES - Construction Stormwater General Permit
  - b. Local requirements and permits
  - c. Other regulatory requirements
5. Stormwater Pollution Prevention Plan (SWPPP)
  - a. SWPPP is a living document – should be revised as necessary
  - b. 12 Elements of a SWPPP; discuss suggested BMPs (with examples)
    1. Mark Clearing Limits
    2. Establish Construction Access
    3. Control Flow Rates
    4. Install Sediment Controls
    5. Stabilize Soils
    6. Protect Slopes
    7. Protect Drain Inlets
    8. Stabilize Channels and Outlets
    9. Control Pollutants
    10. Control De-watering
    11. Maintain BMPs
    12. Manage the Project
6. Monitoring/Reporting/Recordkeeping
  - a. Site inspections/visual monitoring
    - i. Disturbed areas
    - ii. BMPs
    - iii. Stormwater discharge points
  - b. Water quality sampling/analysis
    - i. Turbidity
    - ii. pH
  - c. Monitoring frequency
    - i. Set by NPDES permit
    - ii. Inactive sites - reduced frequency

- d. Adaptive Management
  - i. When monitoring indicates problem, take appropriate action (e.g. install/maintain BMPs)
  - ii. Document the corrective action(s) in SWPPP
- e. Reporting
  - i. Inspection reports/checklists
  - ii. Discharge Monitoring Reports (DMR)
  - iii. Non-compliance notification

### **Instructor Qualifications**

1. Instructors must be qualified to effectively teach the required course elements.
2. At a minimum, instructors must have:
  - a. Current certification as a Certified Professional in Erosion and Sediment Control (CPESC), or
  - b. Completed a training program for teaching the required course elements, or
  - c. The academic credentials and instructional experience necessary for teaching the required course elements.
3. Instructors must demonstrate competent instructional skills and knowledge of the applicable subject matter.

## BMP C220: Storm Drain Inlet Protection

**Purpose** To prevent coarse sediment from entering drainage systems prior to permanent stabilization of the disturbed area.

**Conditions of Use** Where storm drain inlets are to be made operational before permanent stabilization of the disturbed drainage area. Protection should be provided for all storm drain inlets downslope and within 500 feet of a disturbed or construction area, unless the runoff that enters the catch basin will be conveyed to a sediment pond or trap. Inlet protection may be used anywhere to protect the drainage system. It is likely that the drainage system will still require cleaning.

Table 4.9 lists several options for inlet protection. All of the methods for storm drain inlet protection are prone to plugging and require a high frequency of maintenance. Drainage areas should be limited to 1 acre or less. Emergency overflows may be required where stormwater ponding would cause a hazard. If an emergency overflow is provided, additional end-of-pipe treatment may be required.

<b>Table 4.9 Storm Drain Inlet Protection</b>			
<b>Type of Inlet Protection</b>	<b>Emergency Overflow</b>	<b>Applicable for Paved/ Earthen Surfaces</b>	<b>Conditions of Use</b>
<b>Drop Inlet Protection</b>			
Excavated drop inlet protection	Yes, temporary flooding will occur	Earthen	Applicable for heavy flows. Easy to maintain. Large area Requirement: 30' X 30'/acre
Block and gravel drop inlet protection	Yes	Paved or Earthen	Applicable for heavy concentrated flows. Will not pond.
Gravel and wire drop inlet protection	No		Applicable for heavy concentrated flows. Will pond. Can withstand traffic.
Catch basin filters	Yes	Paved or Earthen	Frequent maintenance required.
<b>Curb Inlet Protection</b>			
Curb inlet protection with a wooden weir	Small capacity overflow	Paved	Used for sturdy, more compact installation.
Block and gravel curb inlet protection	Yes	Paved	Sturdy, but limited filtration.
<b>Culvert Inlet Protection</b>			
Culvert inlet sediment trap			18 month expected life.

***Design and  
Installation  
Specifications***

*Excavated Drop Inlet Protection* - An excavated impoundment around the storm drain. Sediment settles out of the stormwater prior to entering the storm drain.

- Depth 1-2 ft as measured from the crest of the inlet structure.
- Side Slopes of excavation no steeper than 2:1.
- Minimum volume of excavation 35 cubic yards.
- Shape basin to fit site with longest dimension oriented toward the longest inflow area.
- Install provisions for draining to prevent standing water problems.
- Clear the area of all debris.
- Grade the approach to the inlet uniformly.
- Drill weep holes into the side of the inlet.
- Protect weep holes with screen wire and washed aggregate.
- Seal weep holes when removing structure and stabilizing area.
- It may be necessary to build a temporary dike to the down slope side of the structure to prevent bypass flow.

*Block and Gravel Filter* - A barrier formed around the storm drain inlet with standard concrete blocks and gravel. See Figure 4.14.

- Height 1 to 2 feet above inlet.
- Recess the first row 2 inches into the ground for stability.
- Support subsequent courses by placing a 2x4 through the block opening.
- Do not use mortar.
- Lay some blocks in the bottom row on their side for dewatering the pool.
- Place hardware cloth or comparable wire mesh with ½-inch openings over all block openings.
- Place gravel just below the top of blocks on slopes of 2:1 or flatter.
- An alternative design is a gravel donut.
- Inlet slope of 3:1.
- Outlet slope of 2:1.
- 1-foot wide level stone area between the structure and the inlet.
- Inlet slope stones 3 inches in diameter or larger.
- Outlet slope use gravel ½- to ¾-inch at a minimum thickness of 1-foot.

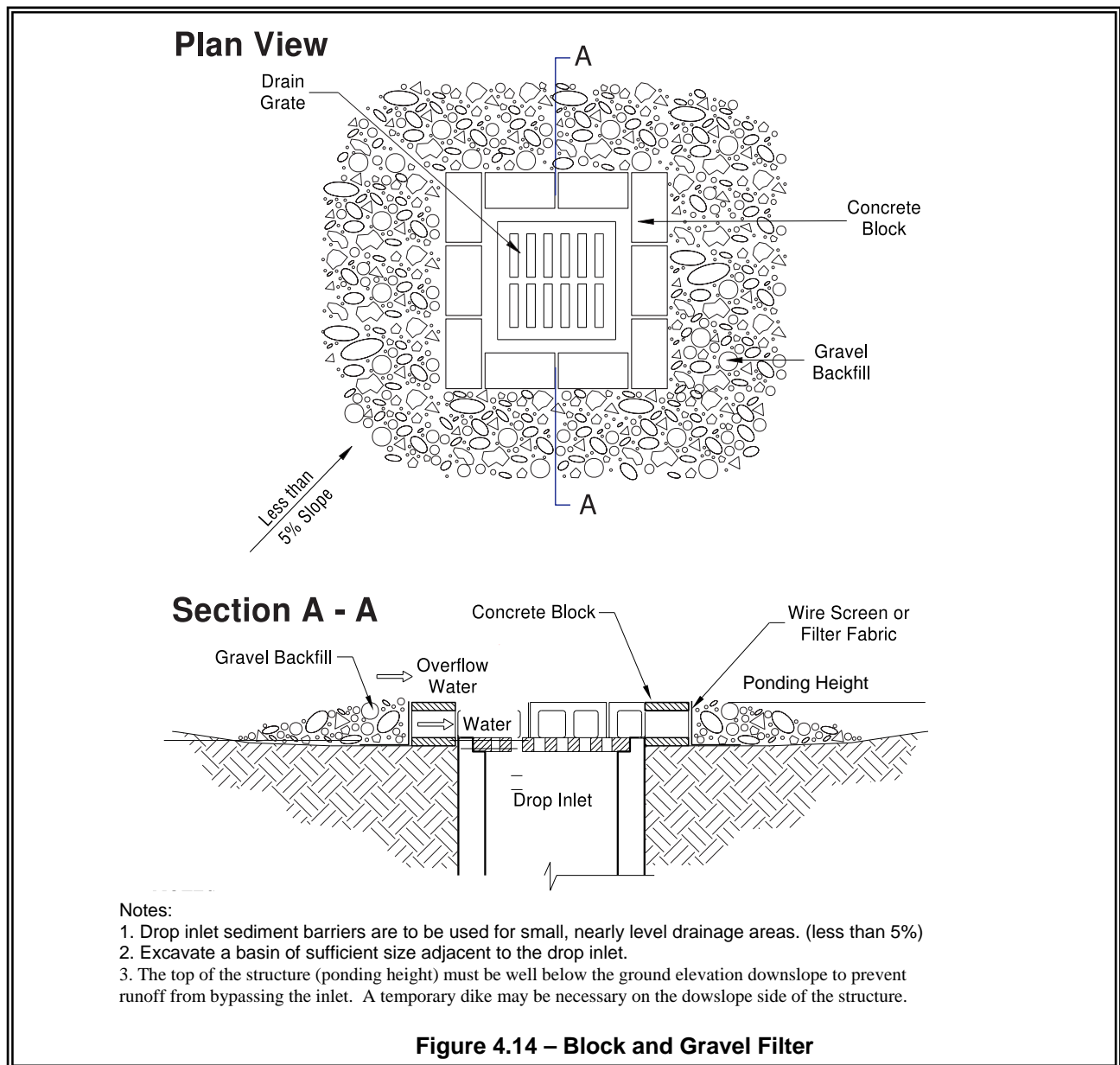

**Figure 4.14 – Block and Gravel Filter**

*Gravel and Wire Mesh Filter* - A gravel barrier placed over the top of the inlet. This structure does not provide an overflow.

- Hardware cloth or comparable wire mesh with ½-inch openings.
- Coarse aggregate.
- Height 1-foot or more, 18 inches wider than inlet on all sides.
- Place wire mesh over the drop inlet so that the wire extends a minimum of 1-foot beyond each side of the inlet structure.
- If more than one strip of mesh is necessary, overlap the strips.
- Place coarse aggregate over the wire mesh.
- The depth of the gravel should be at least 12 inches over the entire inlet opening and extend at least 18 inches on all sides.

*Catchbasin Filters* - Inserts should be designed by the manufacturer for use at construction sites. The limited sediment storage capacity increases the amount of inspection and maintenance required, which may be daily for heavy sediment loads. The maintenance requirements can be reduced by combining a catchbasin filter with another type of inlet protection. This type of inlet protection provides flow bypass without overflow and therefore may be a better method for inlets located along active rights-of-way.

- 5 cubic feet of storage.
- Dewatering provisions.
- High-flow bypass that will not clog under normal use at a construction site.
- The catchbasin filter is inserted in the catchbasin just below the grating.

*Curb Inlet Protection with Wooden Weir* – Barrier formed around a curb inlet with a wooden frame and gravel.

- Wire mesh with ½-inch openings.
- Extra strength filter cloth.
- Construct a frame.
- Attach the wire and filter fabric to the frame.
- Pile coarse washed aggregate against wire/fabric.
- Place weight on frame anchors.

*Block and Gravel Curb Inlet Protection* – Barrier formed around an inlet with concrete blocks and gravel. See Figure 4.14.

- Wire mesh with ½-inch openings.
- Place two concrete blocks on their sides abutting the curb at either side of the inlet opening. These are spacer blocks.
- Place a 2x4 stud through the outer holes of each spacer block to align the front blocks.
- Place blocks on their sides across the front of the inlet and abutting the spacer blocks.
- Place wire mesh over the outside vertical face.
- Pile coarse aggregate against the wire to the top of the barrier.

*Curb and Gutter Sediment Barrier* – Sandbag or rock berm (riprap and aggregate) 3 feet high and 3 feet wide in a horseshoe shape. See Figure 4.16.

- Construct a horseshoe shaped berm, faced with coarse aggregate if using riprap, 3 feet high and 3 feet wide, at least 2 feet from the inlet.
- Construct a horseshoe shaped sedimentation trap on the outside of the berm sized to sediment trap standards for protecting a culvert inlet.

***Maintenance  
Standards***

- Catch basin filters should be inspected frequently, especially after storm events. If the insert becomes clogged, it should be cleaned or replaced.
- For systems using stone filters: If the stone filter becomes clogged with sediment, the stones must be pulled away from the inlet and cleaned or replaced. Since cleaning of gravel at a construction site may be difficult, an alternative approach would be to use the clogged stone as fill and put fresh stone around the inlet.
- Do not wash sediment into storm drains while cleaning. Spread all excavated material evenly over the surrounding land area or stockpile and stabilize as appropriate.

## Plan View

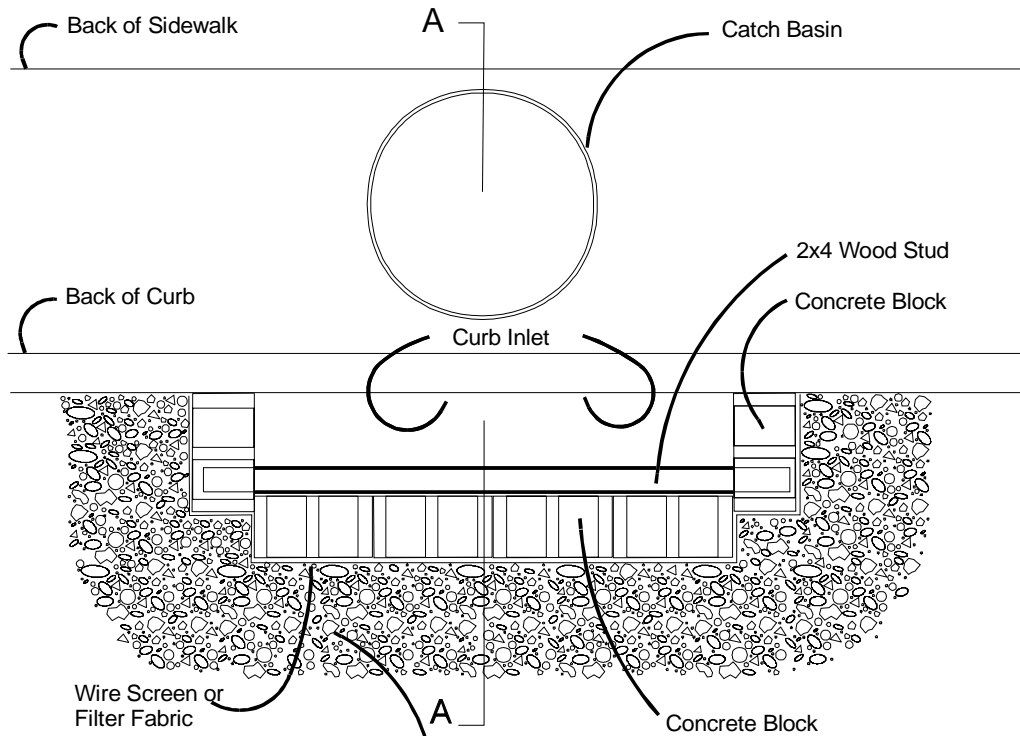

## Section A - A

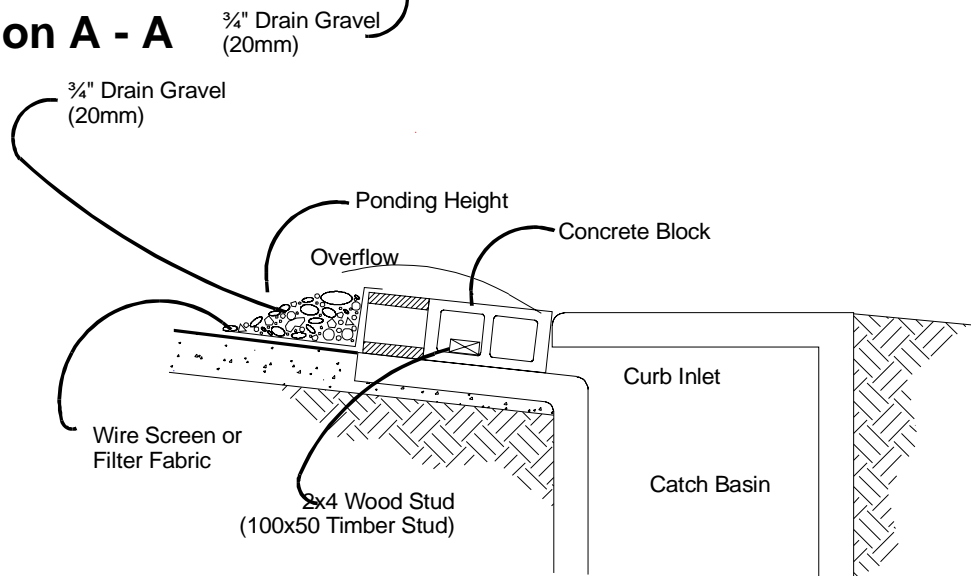

### NOTES:

1. Use block and gravel type sediment barrier when curb inlet is located in gently sloping street segment, where water can pond and allow sediment to separate from runoff.
2. Barrier shall allow for overflow from severe storm event.
3. Inspect barriers and remove sediment after each storm event. Sediment and gravel must be removed from the traveled way immediately.

**Figure 4.15 – Block and Gravel Curb Inlet Protection**



## Plan View

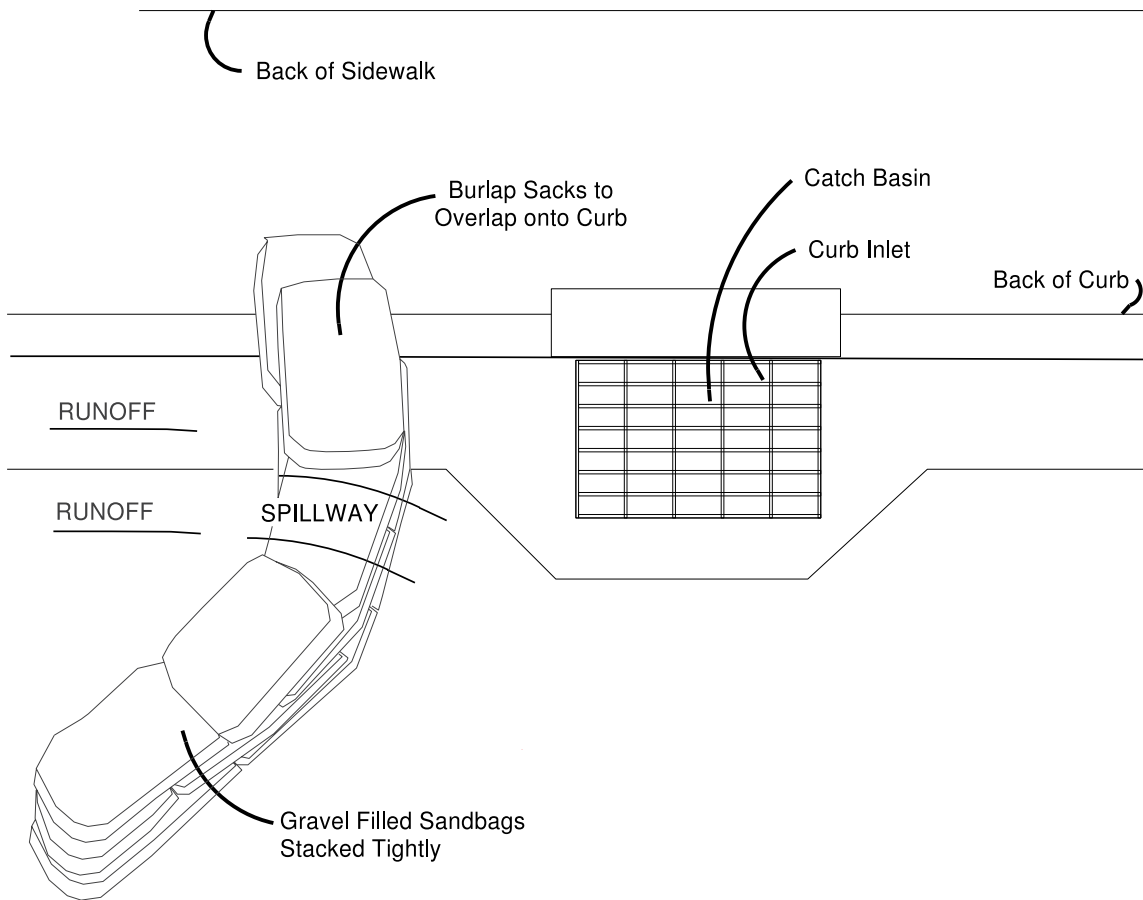

### NOTES:

1. Place curb type sediment barriers on gently sloping street segments, where water can pond and allow sediment to separate from runoff.
2. Sandbags of either burlap or woven 'geotextile' fabric, are filled with gravel, layered and packed tightly.
3. Leave a one sandbag gap in the top row to provide a spillway for overflow.
4. Inspect barriers and remove sediment after each storm event. Sediment and gravel must be removed from the traveled way immediately.

**Figure 4.16 – Curb and Gutter Barrier**

## BMP C233: Silt Fence

### *Purpose*

Use of a silt fence reduces the transport of coarse sediment from a construction site by providing a temporary physical barrier to sediment and reducing the runoff velocities of overland flow. See Figure 4.19 for details on silt fence construction.

### **Conditions of Use**

Silt fence may be used downslope of all disturbed areas.

- Silt fence is not intended to treat concentrated flows, nor is it intended to treat substantial amounts of overland flow. Any concentrated flows must be conveyed through the drainage system to a sediment pond. The only circumstance in which overland flow can be treated solely by a silt fence, rather than by a sediment pond, is when the area draining to the fence is one acre or less and flow rates are less than 0.5 cfs.
- Silt fences should not be constructed in streams or used in V-shaped ditches. They are not an adequate method of silt control for anything deeper than sheet or overland flow.

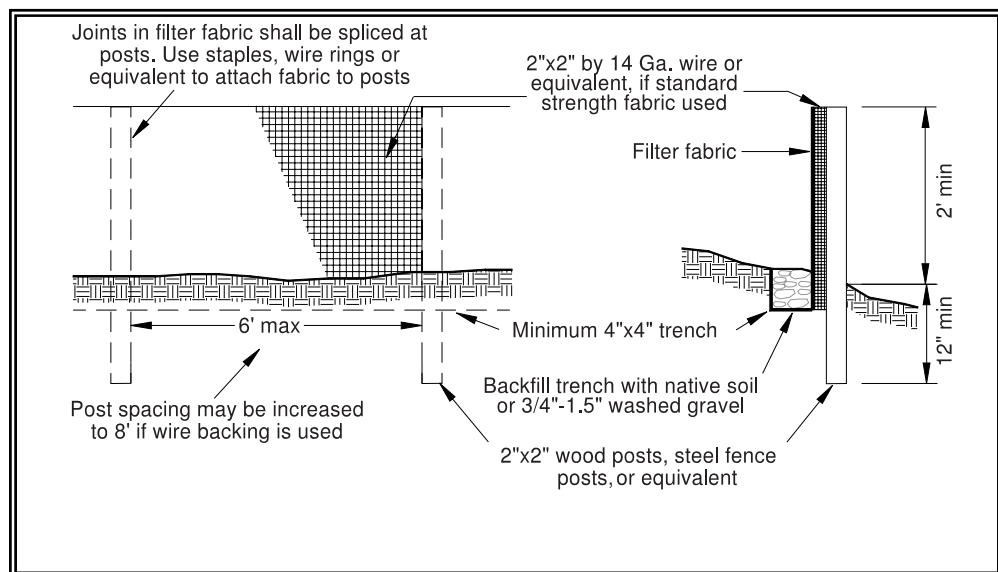

**Figure 4.19 – Silt Fence**

### *Design and Installation Specifications*

- Drainage area of 1 acre or less or in combination with sediment basin in a larger site.
- Maximum slope steepness (normal (perpendicular) to fence line) 1:1.
- Maximum sheet or overland flow path length to the fence of 100 feet.
- No flows greater than 0.5 cfs.
- The geotextile used shall meet the following standards. All geotextile properties listed below are minimum average roll values (i.e., the test result for any sampled roll in a lot shall meet or exceed the values shown in Table 4.10):

Polymeric Mesh AOS (ASTM D4751)	0.60 mm maximum for slit film wovens (#30 sieve). 0.30 mm maximum for all other geotextile types (#50 sieve). 0.15 mm minimum for all fabric types (#100 sieve).
Water Permittivity (ASTM D4491)	0.02 sec <sup>-1</sup> minimum
Grab Tensile Strength (ASTM D4632)	180 lbs. Minimum for extra strength fabric. 100 lbs minimum for standard strength fabric.
Grab Tensile Strength (ASTM D4632)	30% maximum
Ultraviolet Resistance (ASTM D4355)	70% minimum

- Standard strength fabrics shall be supported with wire mesh, chicken wire, 2-inch x 2-inch wire, safety fence, or jute mesh to increase the strength of the fabric. Silt fence materials are available that have synthetic mesh backing attached.
- Filter fabric material shall contain ultraviolet ray inhibitors and stabilizers to provide a minimum of six months of expected usable construction life at a temperature range of 0°F. to 120°F.
- 100 percent biodegradable silt fence is available that is strong, long lasting, and can be left in place after the project is completed, if permitted by local regulations.
- Standard Notes for construction plans and specifications follow. Refer to Figure 4.19 for standard silt fence details.

The contractor shall install and maintain temporary silt fences at the locations shown in the Plans. The silt fences shall be constructed in the areas of clearing, grading, or drainage prior to starting those activities. A silt fence shall not be considered temporary if the silt fence must function beyond the life of the contract. The silt fence shall prevent soil carried by runoff water from going beneath, through, or over the top of the silt fence, but shall allow the water to pass through the fence.

The minimum height of the top of silt fence shall be 2 feet and the maximum height shall be 2½ feet above the original ground surface.

The geotextile shall be sewn together at the point of manufacture, or at an approved location as determined by the Engineer, to form geotextile lengths as required. All sewn seams shall be located at a support post. Alternatively, two sections of silt fence can be overlapped, provided the Contractor can demonstrate, to the satisfaction of the Engineer, that the overlap is long enough and that the adjacent fence sections are close enough together to prevent silt laden water from escaping through the fence at the overlap.

The geotextile shall be attached on the up-slope side of the posts and support system with staples, wire, or in accordance with the manufacturer's recommendations. The geotextile shall be attached to the posts in a manner that reduces the potential for geotextile tearing at the staples, wire, or other connection device. Silt fence back-up support for the geotextile in the form of a wire or plastic mesh is dependent on the properties of the geotextile selected for use. If wire or plastic back-up mesh is used, the mesh shall be fastened securely to the up-slope of the posts with the geotextile being up-slope of the mesh back-up support.

The geotextile at the bottom of the fence shall be buried in a trench to a minimum depth of 4 inches below the ground surface. The trench shall be backfilled and the soil tamped in place over the buried portion of the geotextile, such that no flow can pass beneath the fence and scouring can not occur. When wire or polymeric back-up support mesh is used, the wire or polymeric mesh shall extend into the trench a minimum of 3 inches.

The fence posts shall be placed or driven a minimum of 18 inches. A minimum depth of 12 inches is allowed if topsoil or other soft subgrade soil is not present and a minimum depth of 18 inches cannot be reached. Fence post depths shall be increased by 6 inches if the fence is located on slopes of 3:1 or steeper and the slope is perpendicular to the fence. If required post depths cannot be obtained, the posts shall be adequately secured by bracing or guying to prevent overturning of the fence due to sediment loading.

Silt fences shall be located on contour as much as possible, except at the ends of the fence, where the fence shall be turned uphill such that the silt fence captures the runoff water and prevents water from flowing around the end of the fence.

If the fence must cross contours, with the exception of the ends of the fence, gravel check dams placed perpendicular to the back of the fence shall be used to minimize concentrated flow and erosion along the back of the fence. The gravel check dams shall be approximately 1-foot deep at the back of the fence. It shall be continued perpendicular to the fence at the same elevation until the top of the check dam intercepts the ground surface behind the fence. The gravel check dams shall consist of crushed surfacing base course, gravel backfill for walls, or shoulder ballast. The gravel check dams shall be located every 10 feet along the fence where the fence must cross contours. The slope of the fence line where contours must be crossed shall not be steeper than 3:1.

Wood, steel or equivalent posts shall be used. Wood posts shall have minimum dimensions of 2 inches by 2 inches by 3 feet minimum length, and shall be free of defects such as knots, splits, or gouges.

Steel posts shall consist of either size No. 6 rebar or larger, ASTM A 120 steel pipe with a minimum diameter of 1-inch, U, T, L, or C shape steel posts with a minimum weight of 1.35 lbs./ft. or other steel posts having equivalent strength and bending resistance to the post sizes listed. The spacing of the support posts shall be a maximum of 6 feet.

Fence back-up support, if used, shall consist of steel wire with a maximum mesh spacing of 2 inches, or a prefabricated polymeric mesh. The strength of the wire or polymeric mesh shall be equivalent to or greater than 180 lbs. grab tensile strength. The polymeric mesh must be as resistant to ultraviolet radiation as the geotextile it supports.

- Silt fence installation using the slicing method specification details follow. Refer to Figure 4.20 for slicing method details.

The base of both end posts must be at least 2 to 4 inches above the top of the silt fence fabric on the middle posts for ditch checks to drain properly. Use a hand level or string level, if necessary, to mark base points before installation.

Install posts 3 to 4 feet apart in critical retention areas and 6 to 7 feet apart in standard applications.

Install posts 24 inches deep on the downstream side of the silt fence, and as close as possible to the fabric, enabling posts to support the fabric from upstream water pressure.

Install posts with the nipples facing away from the silt fence fabric.

Attach the fabric to each post with three ties, all spaced within the top 8 inches of the fabric. Attach each tie diagonally 45 degrees through the fabric, with each puncture at least 1 inch vertically apart. In addition, each tie should be positioned to hang on a post nipple when tightening to prevent sagging.

Wrap approximately 6 inches of fabric around the end posts and secure with 3 ties.

No more than 24 inches of a 36-inch fabric is allowed above ground level.

The rope lock system must be used in all ditch check applications.

The installation should be checked and corrected for any deviation before compaction. Use a flat-bladed shovel to tuck fabric deeper into the ground if necessary.

Compaction is vitally important for effective results. Compact the soil immediately next to the silt fence fabric with the front wheel of the tractor, skid steer, or roller exerting at least 60 pounds per square inch. Compact the upstream side first and then each side twice for a total of four trips.

**Maintenance Standards**

- Any damage shall be repaired immediately.
- If concentrated flows are evident uphill of the fence, they must be intercepted and conveyed to a sediment pond.
- It is important to check the uphill side of the fence for signs of the fence clogging and acting as a barrier to flow and then causing channelization of flows parallel to the fence. If this occurs, replace the fence or remove the trapped sediment.
- Sediment deposits shall either be removed when the deposit reaches approximately one-third the height of the silt fence, or a second silt fence shall be installed.
- If the filter fabric (geotextile) has deteriorated due to ultraviolet breakdown, it shall be replaced.

