



FULL SIZED LEDGIBLE **COLOR** PLANS ARE REQUIRED TO BE PROVIDED BY THE PERMITTEE ON SITE FOR ALL INSPECTIONS (MIN. PLAN SIZE 24" X 36")



**FOUNDATION ONLY PERMIT**

**Structural Calculations**

PREPARED FOR:

Red Dot Corporation  
Puyallup Corporate Center  
East Main Avenue at Linden Lane

PROJECT:

Red Dot Corporation  
Bridge Crane Evaluation  
2220760.20

PREPARED BY:

Andrew McEachern, P.E., S.E.  
Principal

DATE:

October 2022

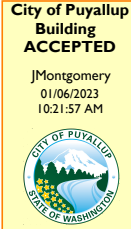

Before final approval, a Final letter of acceptance and approval is required from the W.A.B. Special Inspector for Re-bar, Concrete, Welding and epoxy of Anchors and Bolting. Per Table 1705.3 of the 2018 IBC. SUBMIT REPORTS TO CITY OF PUYALLUP.

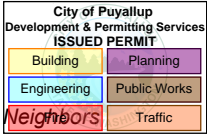



# Structural Calculations For Red Dot Corporation Bridge Crane Evaluation

Project # 2220760.20

Project Principal

Andrew D. McEachern, P.E., S.E.

## Design Criteria

### Design Codes and Standards

Codes and Standards: Structural design and construction shall be in accordance with the applicable sections of the following codes and standards as adopted and amended by the local building authority: International Building Code, 2018 Edition.

### Structural Design Criteria:

#### Live Load Criteria:

Roof (Min Blanket Snow):	25 psf
Slab on Grade:	350 psf

#### Wind Load Criteria:

Basic Wind Speed:	97 mph
Risk Category:	II
Wind Exposure:	B
Topographic Factor:	1.0

#### Seismic Criteria:

Risk Category:	II
Seismic Importance Factor:	1.0
S <sub>s</sub> = 1.258	S <sub>1</sub> = 0.433
S <sub>ds</sub> = 1.006	S <sub>d1</sub> = N/A
Site Class:	D
Seismic Design Category:	D

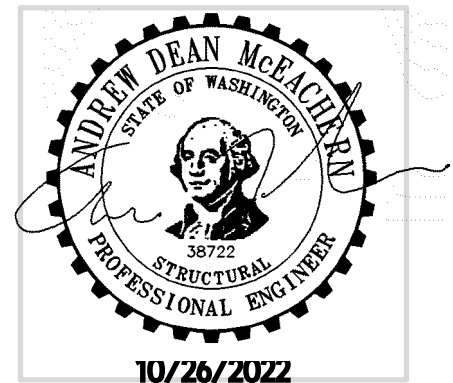

#### Soil Criteria:

Based on Geotechnical Engineering Report by: Terra Associates Inc, dated September 2019.

Soil Bearing Capacity: 2,500 psf when sitting on 2 feet of structural fill on the previously preloaded side. Allow 33% increase for loads from wind or seismic origin.

## Project Description

The scope of work for this project involves a site specific structural evaluation of a previous bridge crane design that will be adapted to a different project site. The bridge crane will be located within an existing building.

It is the intention of the structural design to satisfy the force levels of the IBC 2018.

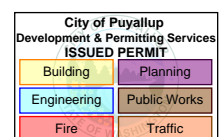

**GENERAL NOTES:**

- FIELD VERIFY ALL DIMENSIONS SHOWN W/ BRIDGE CRANE MFR
- MIN CONCRETE STRENGTH (f'c) 4,000 psi
- VERIFY ANCHORAGE REQUIREMENTS W/ CRANE MFR
- VERIFY SUBGRADE REQUIREMENTS AND SURFACE PREPARATION WITH GEOTECH AND EQUIPMENT MFR.
- PROVIDE GEOPIERS OR EQUIVALENT BELOW FDN PER GEOTECH IF NECESSARY TO MEET SLAB DEFLECTION REQUIREMENTS.

PRCTI20221709

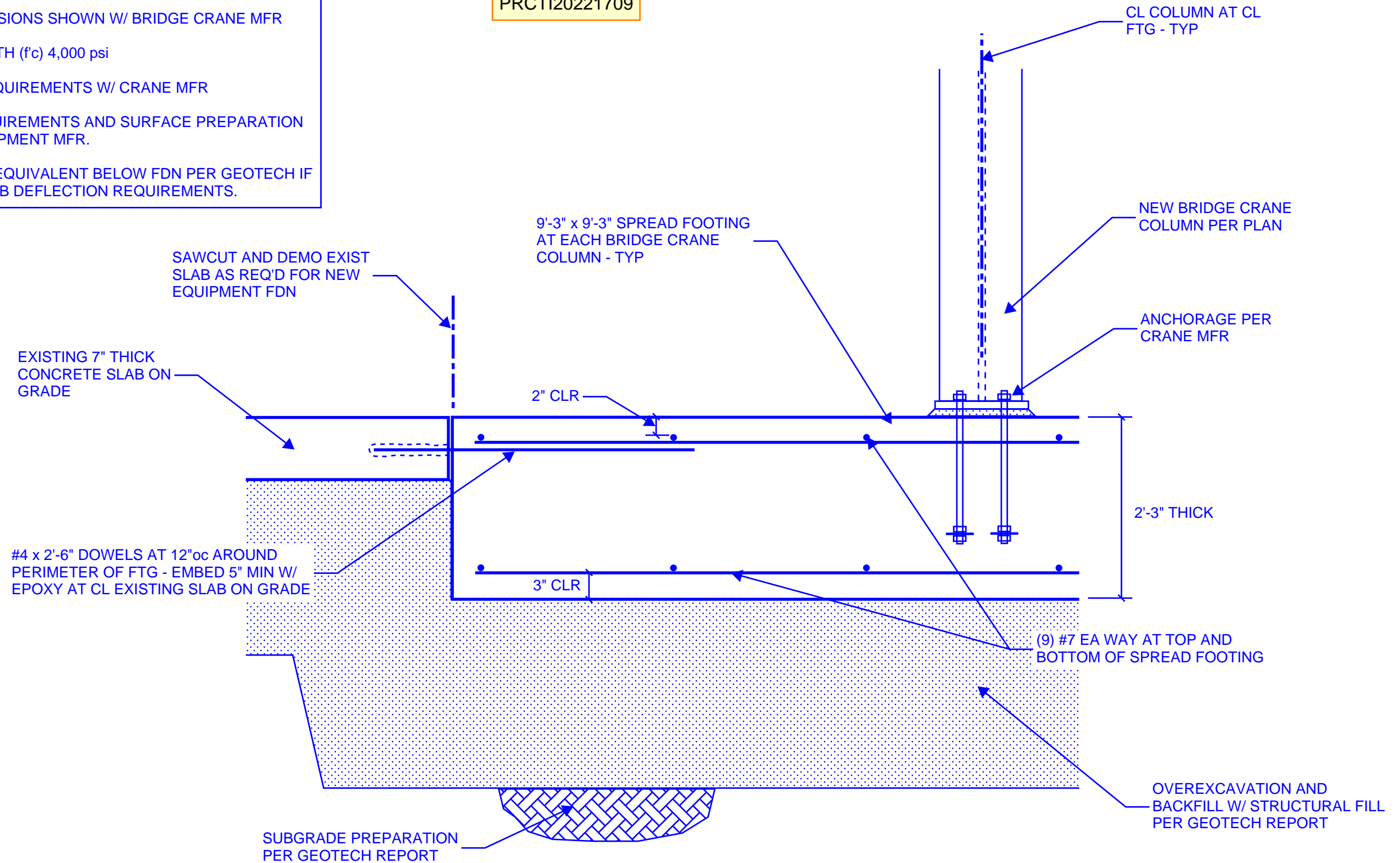

2215 North 30th Street  
Suite 300  
Tacoma, WA 98403  
253.383.2422 TEL  
253.383.2572 FAX

**RED DOT CORPORATION EQUIPMENT FOUNDATIONS**

**BRIDGE CRANE FOUNDATIONS**

DRAWN BY: ADM

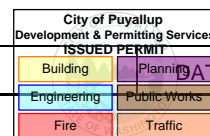

DATE: 10/26/2022

SEE SHEET SHEET 2 FOR ENGINEER OF RECORD SEAL FOR ENCLOSED PLANS.

JOB NO.: 2220760.20

**SSK-A**

THE APPROVED CONSTRUCTION PLANS, DOCUMENTS AND ALL ENGINEERING MUST BE POSTED ON THE JOB AT ALL INSPECTIONS IN A VISIBLE AND READILY ACCESSIBLE LOCATION.

FULL SIZED LEDGIBLE COLOR PLANS ARE REQUIRED TO BE PROVIDED BY THE PERMITEE ON SITE FOR INSPECTION

CLIENT



**PANATTONI**  
DEVELOPMENT  
1821 DOCK ST SUITE 100  
TACOMA, WA 98402

PROJECT

**PUYALLUP CORPORATE CENTER**

EAST MAIN AVENUE AT LINDEN LANE  
PUYALLUP, WASHINGTON

Description:	No:	Date:
PERMIT SUBMITTAL		04/03/2020
PRICING SET	△	07/21/2020
PERMIT RESUBMITTAL		08/24/2020



TACOMA • SEATTLE • SPOKANE • TRI-CITIES

2215 North 30th Street, Suite 300 Tacoma, WA 98403  
253.383.2422 TEL 253.383.2572 FAX www.ahbl.com WEB

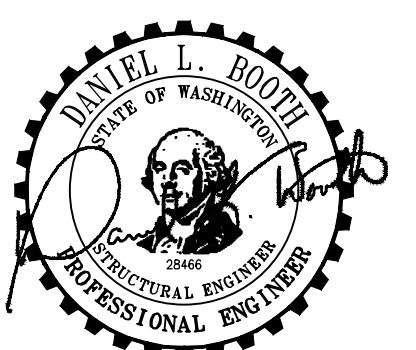

CITY STAMP

NOTICE: ATTENTION OF THE PERMITEE: THIS DOCUMENT IS THE PROPERTY OF NELSON WORLDWIDE AND IS LOANED TO YOU FOR YOUR PROJECT ONLY. IT IS NOT TO BE REPRODUCED OR TRANSMITTED IN ANY FORM OR BY ANY MEANS, ELECTRONIC OR MECHANICAL, INCLUDING PHOTOCOPYING, RECORDING, OR BY ANY INFORMATION STORAGE AND RETRIEVAL SYSTEM. WITHOUT THE WRITTEN PERMISSION OF NELSON WORLDWIDE, THIS DOCUMENT IS NOT TO BE USED FOR ANY OTHER PROJECT.

STRUCTURAL NOTES

Proj. No: 2190390.20 Reviewed By: LAH/CLR

1. STRUCTURAL NOTES

1.1. ANY DISCREPANCY FOUND AMONG THE DRAWINGS, SPECIFICATIONS, THESE NOTES, AND THE SITE CONDITIONS SHALL BE REPORTED TO THE ARCHITECT AND THE STRUCTURAL ENGINEER, WHO SHALL CORRECT SUCH DISCREPANCY IN WRITING. ANY WORK DONE BY THE CONTRACTOR AFTER DISCOVERY OF SUCH DISCREPANCY SHALL BE DONE AT THE CONTRACTOR'S RISK. THE CONTRACTOR SHALL VERIFY AND COORDINATE THE DIMENSIONS AMONG ALL DRAWINGS PRIOR TO PROCEEDING WITH ANY WORK OR FABRICATION. THE CONTRACTOR IS RESPONSIBLE FOR ALL ERECTION BRACING, FORMWORK AND TEMPORARY CONSTRUCTION SHORING.

1.1.1. THE CONTRACTOR SHALL NOT SCALE THE ARCHITECTURAL AND STRUCTURAL DRAWINGS FOR LOCATIONS OF ELEMENTS NOTED ABOVE.

1.1.2. ELECTRONIC COPIES OF THE STRUCTURAL DRAWINGS (PDFS, CAD DRAWINGS OR BIM MODELS) MAY BE PROVIDED TO THE CONTRACTOR FOR THEIR USE. THESE FILES MAY BE PROVIDED AT THE REQUEST OF THE CONTRACTOR FOR THEIR CONVENIENCE ONLY. THE CONTRACTOR AGREES THAT THESE FILES SHALL NOT SUPERSEDE INFORMATION SHOWN ON THE ORIGINAL BID/CONSTRUCTION DOCUMENTS. THE CONTRACTOR AGREES TO HOLD THE STRUCTURAL ENGINEER HARMLESS FOR ANY ERRORS OR DISCREPANCIES CONTAINED WITHIN THESE ELECTRONIC FILES.

1.2. CODES

1.2.1. ALL METHODS, MATERIALS AND WORKMANSHIP SHALL CONFORM TO THE 2015 INTERNATIONAL BUILDING CODE (IBC) AS AMENDED AND ADOPTED BY THE LOCAL BUILDING AUTHORITY.

1.2.2. ALL REFERENCES TO OTHER CODES, STANDARDS AND SPECIFICATIONS, (ACI, ASTM, ETC.), SHALL BE FOR THE EDITION CURRENTLY REFERENCED BY IBC AS AMENDED AND ADOPTED BY THE LOCAL BUILDING AUTHORITY.

1.3. DESIGN CRITERIA

1.3.1. UNIFORM LOADS:

LOCATION	LIVE LOAD	DEAD LOAD
ROOF	25 PSF (SNOW*)	ACTUAL
SLAB ON GRADE (STRUCTURAL)	7' SLAB = 350PSF	ACTUAL
* THIS IS NOT A GROUND SNOW LOAD		

1.3.2. CONCENTRATED LOADS: ALL MANUFACTURERS OF PRE-ENGINEERED COMPONENTS OR SYSTEMS SHALL LOCATE, COORDINATE, VERIFY WEIGHTS, ETC., OF MECHANICAL UNITS OR OTHER CONCENTRATED LOADS AND DESIGN THEIR SYSTEM FOR THESE LOADS.

1.3.3. WIND LOADS (PER IBC SECTION 1609 AND ASCE 7 CHAPTERS 26 THRU 30):

ULTIMATE DESIGN WIND SPEED (V <sub>u</sub> ):	110 MPH
RISK CATEGORY	II
WIND EXPOSURE:	B
APPLICABLE INTERNAL PRESSURE COEFFICIENT:	+/-0.18
TOPOGRAPHIC FACTOR (K <sub>t</sub> ):	1.0 (FLAT)

COMPONENTS AND CLADDING: ULTIMATE DESIGN WIND PRESSURES TO BE USED FOR THE DESIGN OF EXTERIOR COMPONENT AND CLADDING MATERIALS IS AS FOLLOWS:

ZONE:1	+/- 23 PSF (10 SQ FT)
ZONE:2	+/- 39 PSF (10 SQ FT)
ZONE:3	+/- 59 PSF (10 SQ FT)
ZONE:4	+/- 23 PSF (10 SQ FT)
ZONE:5	+/- 28 PSF (10 SQ FT)

1.3.4. SEISMIC LOADS (PER IBC SECTION 1613 AND ASCE 7 CHAPTERS 11 THRU 13):

RISK CATEGORY:	II
SEISMIC IMPORTANCE FACTOR (I <sub>s</sub> ):	1.0
S <sub>s</sub> :	1.257
S <sub>1</sub> :	0.433
SITE CLASS:	D
S <sub>wp</sub> :	0.838
S <sub>ps</sub> :	0.452
SEISMIC DESIGN CATEGORY:	D
SEISMIC RESPONSE COEFFICIENT (C <sub>s</sub> ):	0.168
ANALYSIS PROCEDURE USED:	EQUIVALENT LATERAL FORCE PROCEDURE

SEISMIC FORCE-RESISTING SYSTEM	RESPONSE MODIFICATION COEFFICIENT, R	OVERSTRENGTH FACTOR, Ω <sub>o</sub>
1. SPECIAL REINFORCED CONCRETE SHEAR WALLS	5	2

NOTE: TABULATED OVERSTRENGTH FACTOR HAS BEEN REDUCED IN ACCORDANCE WITH ASCE 7 TABLE 12.2.1 FOOTNOTE G FOR STRUCTURES WITH FLEXIBLE DIAPHRAGMS.

1.4. STATEMENT OF SPECIAL INSPECTIONS

SEE STATEMENT OF SPECIAL INSPECTION AND TESTING SHEET 50.2.

1.5. SHOP DRAWINGS

1.5.1. SUBMIT SHOP DRAWINGS TO THE ARCHITECT/ENGINEER FOR THE FOLLOWING:

- A. CONCRETE MIX DESIGN SUBMITTALS
- B. REINFORCING STEEL
- C. STRUCTURAL AND MISCELLANEOUS STEEL INCLUDING WELD INSERTS AND ANCHORS
- D. PRE-ENGINEERED STEEL JOISTS AND JOIST GIRDERS \*
- E. TILT UP WALLS
- F. PRE-ENGINEERED STEEL STAIRS & CANOPIES \*

\* DEFERRED SUBMITTALS: PRE-ENGINEERED ITEMS SHALL BE SUBMITTED TO THE BUILDING OFFICIAL AFTER REVIEW BY THE ENGINEER OF RECORD AS A DEFERRED SUBMITTAL.

1.5.2. SHOP DRAWING REVIEW NOTES

- A. ENGINEER OF RECORD SHALL REVIEW SHOP DRAWINGS FOR GENERAL CONFORMANCE WITH THE PROJECT CONSTRUCTION DOCUMENTS (PLANS AND SPECIFICATIONS).
- B. ENGINEER OF RECORD REVIEW OF SHOP DRAWINGS SHALL NOT RELIEVE THE GENERAL CONTRACTOR OF THEIR RESPONSIBILITY FOR REVIEW OF THE SHOP DRAWINGS FOR COMPLIANCE WITH THE PROJECT REQUIREMENTS.
- C. APPROVAL OF THE SHOP DRAWINGS BY THE ENGINEER OF RECORD SHALL NOT BE CONSIDERED AS A GUARANTEE BY THE ENGINEER THAT THE SHOP DRAWINGS COMPLY WITH ALL PROJECT REQUIREMENTS.
- D. CONCURRENT SHOP DRAWING REVIEW SHALL ONLY BE PERMITTED IF APPROVED BY THE ARCHITECT/ENGINEER OF RECORD PRIOR TO THE START OF SHOP DRAWING REVIEW.

1.6. MISCELLANEOUS

- 1.6.1. VERIFY ALL DIMENSIONS AND CONDITIONS IN THE FIELD.
- 1.6.2. VERIFY SIZE AND LOCATION OF ALL OPENINGS IN THE FLOORS, ROOF AND WALLS WITH ARCHITECTURAL, MECHANICAL AND ELECTRICAL DRAWINGS.
- 1.6.3. CONSTRUCTION DETAILS NOT SPECIFICALLY SHOWN ON THE DRAWINGS SHALL FOLLOW SIMILAR DETAILS OF SECTIONS OF THIS PROJECT AS APPROVED BY THE ARCHITECT/ENGINEER.
- 1.6.4. SEE ARCHITECTURAL, MECHANICAL AND ELECTRICAL DRAWINGS FOR DIMENSIONS AND LOCATIONS OF OPENINGS NOT DIMENSIONED OR SHOWN ON STRUCTURAL PLANS.
- 1.6.5. SEE ARCHITECTURAL, MECHANICAL AND ELECTRICAL DRAWINGS FOR LOCATIONS AND WEIGHTS OF ALL MECHANICAL AND ELECTRICAL EQUIPMENT INCLUDING HOUSEKEEPING PADS.
- 1.6.6. FOR PIPES, CONDUITS, DUCTS AND MECHANICAL EQUIPMENT SUPPORTED OR BRACED FROM STRUCTURE: CONFORM TO SHEET METAL AND AIR CONDITIONING CONTRACTORS NATIONAL ASSOCIATION, INC., PUBLICATION "APPENDIX E: SEISMIC RESTRAINT MANUAL GUIDELINES FOR MECHANICAL SYSTEMS", ALL BRACING AND SUPPORTS SHALL BE DESIGNED FOR SEISMIC HAZARD LEVEL (SHL) B. SPRINKLER LINE ATTACHMENTS SHALL CONFORM TO NFPA PAMPHLET 13.
- 1.6.7. THE STRUCTURE HAS BEEN DESIGNED TO RESIST CODE REQUIRED VERTICAL AND LATERAL FORCES AFTER THE CONSTRUCTION OF ALL STRUCTURAL ELEMENTS HAS BEEN COMPLETED. STABILITY OF THE STRUCTURE PRIOR TO COMPLETION IS THE SOLE RESPONSIBILITY OF THE GENERAL CONTRACTOR. THIS RESPONSIBILITY INCLUDES BUT IS NOT LIMITED TO JOB SITE SAFETY, ERECTION MEANS, METHODS, AND SEQUENCES, TEMPORARY SHORING, FORMWORK, AND BRACING; USE OF EQUIPMENT AND CONSTRUCTION PROCEDURES. WHERE SHORING IS REQUIRED, A SHORING PLAN, STAMPED BY A LICENSED PROFESSIONAL STRUCTURAL ENGINEER SHALL BE SUBMITTED TO THE ENGINEER FOR APPROVAL.

2. SITE PREPARATION/SOIL REMEDIATION

2.1. SOIL DATA

ALLOWABLE SOIL PRESSURE 2500 PSF WHEN SITTING ON 2' OF STRUCTURAL FILL AND PRELOADED SITE. ALLOW 33-10% INCREASE FOR LOADS FROM WIND OR SEISMIC ORIGIN. SEE GEOTECHNICAL ENGINEERING REPORT BY TERRA ASSOCIATES INC DATED SEPTEMBER 2019. SEE GEOTECH REPORT FOR ALL SUBGRADE PREPARATION REQUIREMENTS AS WELL AS CAPILLARY BREAK AND VAPOR BARRIER RECOMMENDATIONS.

2.2. EXCAVATION

EXCAVATE TO DEPTH SHOWN AND TO FIRM UNDISTURBED MATERIAL. OVER-EXCAVATIONS SHALL BE BACKFILLED WITH LEAN CONCRETE (f'<sub>c</sub>=5000-12000 PSI) OR STRUCTURAL FILL AT THE CONTRACTOR'S EXPENSE. EXERCISE EXTREME CARE DURING EXCAVATION TO AVOID DAMAGE TO BURIED LINES, TANKS, AND OTHER CONCEALED ITEMS. UPON DISCOVERY, DO NOT PROCEED WITH WORK UNTIL RECEIVING WRITTEN INSTRUCTIONS FROM THE ARCHITECT. A COMPETENT REPRESENTATIVE OF THE OWNER SHALL INSPECT ALL FOOTING EXCAVATIONS FOR SUITABILITY OF BEARING SURFACES PRIOR TO PLACEMENT OF REINFORCING STEEL. PROVIDE DRAINAGE AS NECESSARY TO AVOID WATER-SOFTENED SUBGRADE.

2.3. FILL, BACKFILL AND COMPACTION

BACKFILL AGAINST WALLS SHALL NOT BE PLACED UNTIL AFTER THE REMOVAL OF ALL MATERIAL SUBJECT TO ROT OR CORROSION. ALL FILL PLACED AGAINST RETAINING WALLS OR BASEMENT WALLS SHALL BE FREE DRAINING GRANULAR MATERIAL. STRUCTURAL FILL OTHER THAN PEA GRAVEL SHALL BE GRANULAR PLACED IN 6-INCH LIFTS AND COMPACTED TO AT LEAST 95% OF ITS MAXIMUM DRY DENSITY AS DETERMINED BY ASTM D-1557 (MOD PROCTOR). PEA GRAVEL FILL SHALL HAVE A MAXIMUM PARTICLE SIZE OF 3/8" DIAMETER.

3. STRUCTURAL CONCRETE

3.1. GENERAL

ALL CONCRETE SHALL BE HARD ROCK CONCRETE MEETING THE REQUIREMENTS OF ACI-301, "SPECIFICATIONS FOR STRUCTURAL CONCRETE FOR BUILDINGS." PROPORTIONING OF INGREDIENTS FOR EACH CONCRETE MIX SHALL BE BY METHOD 2 OR THE ALTERNATE PROCEDURE GIVEN IN ACI-301. PLACE CONCRETE PER ACI-304 AND CONFORM TO ACI-604 (306) FOR WINTER CONCRETING AND ACI-605 (305) FOR HOT WEATHER CONCRETING. USE INTERIOR MECHANICAL VIBRATORS WITH 7,000 RPM MINIMUM FREQUENCY. DO NOT OVER-VIBRATE. CONCRETE SHALL BE PLACED MONOLITHICALLY BETWEEN CONSTRUCTION OR CONTROL JOINTS. PROTECT ALL CONCRETE FROM PREMATURE DRYING, EXCESSIVE HOT OR COLD TEMPERATURE FOR SEVEN DAYS AFTER PLACING.

3.2. STRENGTH

TWENTY-EIGHT DAY COMPRESSIVE STRENGTHS SHALL BE AS FOLLOWS:

SLABS ON GRADE	4000 PSI
FOOTINGS	3000 PSI
VERTICALLY FORMED WALLS	4000 PSI
TILT UP WALL PANELS	4000 PSI

3.3. MATERIALS

3.3.1. CEMENT: ASTM C150, TYPE I OR TYPE II. ENGINEER'S APPROVAL IS NEEDED FOR USE OF TYPE III CEMENT.

3.3.2. COARSE AND FINE AGGREGATE: ASTM C33.

3.3.3. WATER SHALL BE CLEAN AND POTABLE.

3.3.4. FLYASH: ASTM C618 CLASS C OR CLASS F

3.3.5. GROUND GRANULATED BLAST FURNACE SLAG (GGBSF): SHALL NOT BE PERMITTED.

3.4. ADMIXTURES

- 3.4.1. WATER REDUCING ADMIXTURE: ASTM C494. ADMIXTURES SHALL BE USED IN EXACT ACCORDANCE WITH MANUFACTURER'S INSTRUCTIONS.
  - 3.4.2. WATER REDUCING ADMIXTURES SHALL BE USED AT ALL HEAVILY CONGESTED AREAS (I.E. CONCRETE WALLS WITH REINFORCING SPACING OF 4" OR LESS)
  - 3.4.3. CONCRETE USING ADMIXTURES TO PRODUCE FLOWABLE CONCRETE MAY BE USED SUBJECT TO ENGINEER'S APPROVAL.
  - 3.4.4. AIR ENTRAINMENT: ASTM C260 AND ASTM C494 ENTRAIN 5% PLUS/MINUS 1.5% BY VOLUME IN ALL CONCRETE EXPOSED TO WEATHER.
  - 3.4.5. NO OTHER ADMIXTURES PERMITTED UNLESS APPROVED BY THE ENGINEER.
- 3.5. FORMWORK AND SHORING
- 3.5.1. FOLLOW RECOMMENDED PRACTICE FOR CONCRETE FORMWORK (ACI-307).
  - 3.5.2. ALL SHORING SHALL BE THE RESPONSIBILITY OF THE CONTRACTOR. FORMWORK SUPPORTS SHALL BE DESIGNED TO PROVIDE FINISHED CONCRETE SURFACES AT ALL FACES LEVEL, PLUMB AND TRUE TO THE DIMENSIONS AND ELEVATIONS SHOWN. TOLERANCES AND VARIATIONS SHALL BE AS SPECIFIED. A SHORING PLAN, STAMPED BY A LICENSED PROFESSIONAL ENGINEER SHALL BE SUBMITTED TO THE ENGINEER FOR APPROVAL.
- 3.6. REINFORCING STEEL:
- 3.6.1. DETAIL FABRICATE, AND PLACE PER ACI-315 AND ACI-318. SUPPORT REINFORCEMENT WITH APPROVED CHAIRS, SPACERS, OR TIES.
  - 3.6.2. DEFORMED BAR REINFORCEMENT: ASTM A615 GR 60
  - 3.6.3. WELDABLE DEFORMED BAR REINFORCEMENT: ASTM A706 GR 60 WHERE NOTED ON STRUCTURAL DRAWINGS
  - 3.6.4. WELDED WIRE FABRIC: ASTM A-185 & ASTM A-82 Fy=65 KSI
  - 3.6.5. DEFORMED BAR ANCHORS: ASTM A-496
  - 3.6.6. EXCEPT AS NOTED SPECIFICALLY ON THE DRAWINGS, ALL CONCRETE REINFORCEMENT SHALL BE LAP-SPLICED AS FOLLOWS:
    - #6 AND SMALLER 48 X BAR DIAMETER
    - NO MORE THAN 50% HORIZONTAL OR VERTICAL BARS SHALL BE SPLICED AT ONE LOCATION
  - 3.6.7. EXCEPT AS NOTED SPECIFICALLY ON THE DRAWINGS, PROVIDE CORNER BARS TO MATCH QUANTITY AND DIAMETER OF HORIZONTAL REINFORCEMENT AND LAP WITH HORIZONTAL REINFORCEMENT AS FOLLOWS:
    - #6 AND SMALLER 48 X BAR DIAMETER
    - THESE CORNER BARS SHALL BE PLACED AT ALL CORNERS AND INTERSECTIONS IN CONCRETE FOOTINGS AND WALLS.
  - 3.6.8. LAP WELDED WIRE FABRIC 12" OR ONE SPACING PLUS 2", WHICHEVER IS MORE.

EXPANSION ANCHORS IN CONCRETE	CODE REPORT
HILTI KWIK BOLT TZ	ICC ESR-1917
SIMPSON STRONG-BOLT 2	ICC ESR-3037
DEWALT/POWERS POWER-STUD+ SD2	ICC ESR-2502

BOTTOM OF FOOTINGS	3"
FORMED EARTH FACE	2"
WALLS, WEATHER FACE	1-1/2"
WALLS, INSIDE FACE	1"

3.7. CONCRETE COVER ON REINFORCING SHALL BE AS FOLLOWS (UNLESS SHOWN OTHERWISE):

7" SLAB ON GRADE	20'-0" O.C. MAX
------------------	-----------------

3.8. CONSTRUCTION AND CONTROL JOINTS

3.8.1. UNLESS NOTED OTHERWISE, LOCATION OF THE CONSTRUCTION OR CONTROL JOINTS IN SLAB ON GRADE SHALL NOT EXCEED THE DISTANCES NOTED BELOW. JOINTS SHALL BE LOCATED ON COLUMN GRIDS OR UNDER PERMANENT PARTITIONS TO THE GREATEST EXTENT POSSIBLE. ADDITIONAL JOINTS SHALL BE REQUIRED AT REINTRACT CORNERS AND CORNERS OF SLAB PENETRATIONS OR PENETRATIONS. SEE ARCHITECTURAL DRAWINGS FOR JOINT LAYOUT AT EXPOSED CONCRETE CONDITIONS. PROVIDE JOINT SEALANT PER SPECIFICATIONS - INSTALL PER MANUFACTURER RECOMMENDATIONS.

ADHESIVE ANCHORS IN CONCRETE	CODE REPORT
HILTI HIT HY-200 SAFE SET	ICC ESR-3187
SIMPSON AT-XP *	IAPMO ER-263
DEWALT/POWERS PURE 110+	ICC ESR-3298

\* SIMPSON SET-XP MAY BE USED WHERE BASE MATERIAL TEMPERATURE IS ABOVE 50 DEGREES FAHRENHEIT OR FOR EMBEDMENT GREATER THAN 12-INCHES FOR LONGER GEL TIME. SEE ICC ESR-2508 (CONC) AND IAPMO ER-265 (MASONRY).

F. POWDER ACTUATED FASTENERS: PDFS OR PAFS SHALL BE A MINIMUM 0.157" DIA KNURLED SHANK FASTENER AS NOTED IN THE FOLLOWING TABLE, UNLESS NOTED OTHERWISE. FASTENERS DRIVEN INTO STEEL SHALL BE DRIVEN SO THAT THE POINT OF THE FASTENER COMPLETELY PENETRATES THE STEEL BASE MATERIAL AT TOPPING SLABS, PT SLABS OR SLABS WITH RADIANT HEAT TUBES EMBEDDED WITHIN THE SLAB, LIMIT THE PDF PENETRATION TO 3/4" MAXIMUM AND COORDINATE WITH TENDON/TUBE PLACEMENT AND COVER.

POWDER ACTUATED FASTENERS	CODE REPORT
HILTI X-J	ICC ESR-2269
SIMPSON PDPA	ICC ESR-2138
DEWALT/POWERS CSI PIN	ICC ESR-2024

5.2.5. METAL PROTECTION: ALL STEEL EXPOSED TO WEATHER, MOISTURE, SOIL, OR AS NOTED SHALL BE GALVANIZED PER ASTM A-123 OR A153 AS APPLICABLE. ALL OTHER STEEL SURFACES SHALL BE SHOP PRIMED AFTER FABRICATION.

REPAIR ALL DAMAGED AREAS OF GALVANIZED PARTS SUCH AS FIELD WELDS, ETC. APPLY REPAIR COATING THICKNESS GREATER THAN OR EQUAL TO ORIGINAL ZINC COATING THICKNESS.

5.2.6. STEEL COLUMNS: ALL VERTICAL LOAD CARRYING MEMBERS HAVE BEEN NOTED AS "COLUMNS" ON THE STRUCTURAL DRAWINGS. THIS NOTATION DOES NOT IDENTIFY THESE MEMBERS AS "POSTS" OR "COLUMNS" AS DEFINED BY THE LATEST OSHA RULES REGARDING COLUMN ANCHORAGE REQUIREMENTS (OSHA 29 CFR PARTS 1926.751 AND 1926.755). THE GENERAL CONTRACTOR, STEEL DETAILER, AND STEEL ERECTOR SHALL BE RESPONSIBLE TO DETERMINE THE CORRECT OSHA DESIGNATION OF EACH MEMBER REGARDLESS OF THE NOTATION SHOWN ON THE STRUCTURAL DRAWINGS.

5.2.7. PRE-ENGINEERED STEEL STAIRS AND CANOPIES: THE MANUFACTURER SHALL SUBMIT SHOP DRAWINGS AND CALCULATIONS SEALED BY A PROFESSIONAL ENGINEER LICENSED IN THE STATE OF THE PROJECT.

5. METALS

5.1. STRUCTURAL STEEL GENERAL REQUIREMENTS

5.1.1. ALL DETAILING, FABRICATION, AND ERECTION SHALL CONFORM TO AISC 360-10 "SPECIFICATION FOR STRUCTURAL STEEL BUILDINGS", AISC 341-10 "SEISMIC PROVISIONS FOR STRUCTURAL STEEL BUILDINGS" AND AISC 303-10 "CODE OF STANDARD PRACTICE FOR STEEL BUILDINGS AND BRIDGES" EXCEPT AS AMENDED BY THESE STRUCTURAL NOTES.

5.2. STRUCTURAL STEEL

5.2.1. STEEL W SHAPES SHALL BE ASTM A992 F<sub>y</sub>=50 KSI. OTHER SHAPES AND PLATES SHALL BE ASTM A36 F<sub>y</sub>=36 KSI.

5.2.2. RECTANGULAR HOLLOW STEEL SECTIONS (HSS) OR TUBE STEEL SECTIONS (TS) SHALL BE ASTM A500, GRADE B, F<sub>y</sub>=46 KSI (F<sub>y</sub>=42 KSI FOR ROUND SECTIONS)

5.2.3. BOLTS

- A. MACHINE BOLTS NOT SPECIFIED AS HIGH STRENGTH SHALL BE ASTM A-307 GRADE A.
- B. HIGH STRENGTH BOLTS SHALL BE ASTM F3125 GRADE A325 OR GRADE A490 AS INDICATED ON STRUCTURAL DRAWINGS. ALL BOLTS SHALL BE CONSIDERED BEARING TYPE WITH THREADS INCLUDED IN SHEAR PLANE (CONNECTION TYPE N) UNLESS NOTED OTHERWISE. ALL HIGH STRENGTH BOLTED CONNECTIONS SHALL BE INSTALLED WITH NUTS CONFORMING TO ASTM A563 AND HARDENED WASHERS CONFORMING TO ASTM F436.
- C. ALL HIGH STRENGTH BOLTS SHALL BE INSTALLED PER THE SPECIFICATION FOR STRUCTURAL JOINTS USING HIGH-STRENGTH BOLTS (LATEST EDITION) BY THE RESEARCH COUNCIL ON STRUCTURAL CONNECTIONS (WWW.BOLTCOUNCIL.ORG).

5.2.4. STEEL ANCHORAGE ELEMENTS:

- A. THREADED RODS SHALL BE ALL-THREAD, (F<sub>y</sub>=36 KSI) U.N.O.
- B. WELDED HEADED STUDS, "NELSON STUDS" SHALL BE BY NELSON STUD WELDING, INC. OR APPROVED EQUIVALENT COMPLYING WITH ASTM A108. STUDS SHALL HAVE A MINIMUM F<sub>y</sub> OF 65 KSI.
- C. ANCHOR RODS: ANCHOR RODS SHALL BE ASTM F 1554, F<sub>y</sub>=36 KSI.
- D. EXPANSION ANCHORS SHALL BE CARBON STEEL AS NOTED IN THE FOLLOWING TABLE. ANCHORS IN CONCRETE SHALL HAVE BEEN TESTED IN ACCORDANCE WITH ACI 308.2 AND/OR ICC-ES E-1293 FOR CRACKED CONCRETE AND SEISMIC APPLICATIONS. ANCHORS SHALL HAVE A CURRENT CODE REPORT THAT COMPLIES WITH THE CURRENT EDITION OF THE IBC AND SHALL BE RATED FOR USE IN THE SEISMIC DESIGN CATEGORY NOTED IN THE DESIGN CRITERIA SECTION OF THESE NOTES.

EXPANSION ANCHORS IN CONCRETE	CODE REPORT
HILTI KWIK BOLT TZ	ICC ESR-1917
SIMPSON STRONG-BOLT 2	ICC ESR-3037
DEWALT/POWERS POWER-STUD+ SD2	ICC ESR-2502

E. ADHESIVE ANCHORS SHALL BE THREADED ANCHOR RODS OR REBAR DOWELS USING AN INJECTABLE ADHESIVE AS NOTED IN THE FOLLOWING TABLE. ANCHORS IN CONCRETE SHALL HAVE BEEN TESTED IN ACCORDANCE WITH ACI 308.2 AND/OR ICC-ES AC-308 FOR CRACKED CONCRETE AND SEISMIC APPLICATIONS. ANCHORS SHALL HAVE A CURRENT CODE REPORT THAT COMPLIES WITH THE CURRENT EDITION OF THE IBC AND SHALL BE RATED FOR USE IN THE SEISMIC DESIGN CATEGORY NOTED IN THE DESIGN CRITERIA SECTION OF THESE NOTES.

ADHESIVE ANCHORS IN CONCRETE	CODE REPORT
HILTI HIT HY-200 SAFE SET	ICC ESR-3187
SIMPSON AT-XP *	IAPMO ER-263
DEWALT/POWERS PURE 110+	ICC ESR-3298

F. POWDER ACTUATED FASTENERS: PDFS OR PAFS SHALL BE A MINIMUM 0.157" DIA KNURLED SHANK FASTENER AS NOTED IN THE FOLLOWING TABLE, UNLESS NOTED OTHERWISE. FASTENERS DRIVEN INTO STEEL SHALL BE DRIVEN SO THAT THE POINT OF THE FASTENER COMPLETELY PENETRATES THE STEEL BASE MATERIAL AT TOPPING SLABS, PT SLABS OR SLABS WITH RADIANT HEAT TUBES EMBEDDED WITHIN THE SLAB, LIMIT THE PDF PENETRATION TO 3/4" MAXIMUM AND COORDINATE WITH TENDON/TUBE PLACEMENT AND COVER.

POWDER ACTUATED FASTENERS	CODE REPORT
HILTI X-J	ICC ESR-2269
SIMPSON PDPA	ICC ESR-2138
DEWALT/POWERS CSI PIN	ICC ESR-2024

6. CARPENTRY

DIMENSION LUMBER SHALL BE #2 SAWN LUMBER BEAMS, HEADERS AND COLUMNS SHALL BE DFR2 OR AS SHOWN ON THE DRAWINGS. ALL 2" NOMINAL LUMBER SHALL BE KILN DRIED (KD). EACH PIECE OF LUMBER SHALL BEAR STAMP OF WEST COAST LUMBER INSPECTION BUREAU (WCLIB) AND/OR WESTERN WOOD PRODUCTS ASSOCIATION (WWPA) SHOWING GRADE MARK.

6.1. PRESSURE-PRESERVATIVE TREATMENT IN ACCORDANCE WITH AMERICAN WOOD PROTECTION ASSOCIATION (AWPA) STANDARD U1, LATEST EDITION TO THE USE CATEGORY AS FOLLOWS:

6.1.1. TREAT ALL WOOD IN CONTACT WITH CONCRETE, MORTAR, GROUT, MASONRY AND WITHIN 12" OF EARTH TO THE REQUIREMENTS OF USE CATEGORY UC2 (INTERIOR/DAMP).

6.2. CARPENTRY HARDWARE

6.2.1. MACHINE BOLTS SHALL BE ASTM A-307.

6.2.2. PROVIDE MALLEABLE IRON WASHERS (MIW) OR HEAVY PLATE CUT WASHERS WHERE BOLT HEADS, NUTS OR LAG SCREWS BEAR ON WOOD.

6.2.3. NAILS SHALL BE COMMON, AMERICAN OR CANADIAN MANUFACTURER ONLY WITH MIN. DIAMETERS AS FOLLOWS:

NAIL SIZE	MINIMUM NAIL SHANK DIAMETER	MINIMUM NAIL LENGTH
8d	0.131"	2 1/2"
10d	0.148"	3"
12d	0.148"	3 1/4"
16d SINKER	0.148"	3 1/4"
16d	0.162"	3 1/2"
20d	0.192"	4"

6.2.4. STEEL COLUMNS: ALL VERTICAL LOAD CARRYING MEMBERS HAVE BEEN NOTED AS "COLUMNS" ON THE STRUCTURAL DRAWINGS. THIS NOTATION DOES NOT IDENTIFY THESE MEMBERS AS "POSTS" OR "COLUMNS" AS DEFINED BY THE LATEST OSHA RULES REGARDING COLUMN ANCHORAGE REQUIREMENTS (OSHA 29 CFR PARTS 1926.751 AND 1926.755). THE GENERAL CONTRACTOR, STEEL DETAILER, AND STEEL ERECTOR SHALL BE RESPONSIBLE TO DETERMINE THE CORRECT OSHA DESIGNATION OF EACH MEMBER REGARDLESS OF THE NOTATION SHOWN ON THE STRUCTURAL DRAWINGS.

6.2.5. PRE-ENGINEERED STEEL STAIRS AND CANOPIES: THE MANUFACTURER SHALL SUBMIT SHOP DRAWINGS AND CALCULATIONS SEALED BY A PROFESSIONAL ENGINEER LICENSED IN THE STATE OF THE PROJECT.

**FOUNDATION NOTES:**

- SEE SHEET S0.1 AND S0.2 FOR GENERAL NOTES. SEE SHEET S0.4 FOR TYPICAL DETAILS. SEE SHEET S0.3 FOR TESTING AND INSPECTION NOTES.
- SEE GEOTECHNICAL ENGINEERING REPORT FOR ALL FOUNDATION AND SLAB SUPPORT REQUIREMENTS. THIS INCLUDES ALL EXCAVATION, FILL AND FILL PLACEMENT REQUIREMENTS.
- SEE ARCHITECTURAL/MECHANICAL DRAWINGS FOR DRAINS, SLOPES, AND OTHER FLOOR DEPRESSIONS NOT SHOWN.
- SEE ARCHITECTURAL DRAWINGS FOR DIMENSIONS, ELEVATIONS, AND WALLS NOT SHOWN.
- VERIFY ALL WINDOW AND DOOR WIDTH AND HEIGHTS WITH ARCHITECTURAL DRAWINGS.
- SEE ARCHITECTURAL DRAWINGS FOR STUD SIZE, SPACING, AND CALLOUTS AT NON-STRUCTURAL WALLS.
- FOR TYPICAL CONNECTION OF NON-LOAD BEARING WALLS TO SLAB, USE POWER ACTUATED FASTENERS AT 16" O.C.
- PANEL DIMENSIONS SHOWN ARE TO CENTERLINE OF PANEL JOINT. SEE ARCHITECTURAL DRAWINGS FOR ADDITIONAL PANEL DIMENSIONS.
- ELEVATIONS OF PANELS ARE SHOWN STARTING ON SHEET S5.1 THROUGH S5.6.
- UNLESS NOTED OTHERWISE, TILT-UP PANEL ELEVATIONS SHOW PANELS VIEWED FROM INSIDE OF BUILDING LOOKING TOWARDS BUILDING EXTERIOR.
- POUR STRIP CONTROL JOINTS, LOCATE AT PANEL JOINTS AND MIDWAY BETWEEN AT TURNS IN POUR STRIP. ADD JOINTS FROM MAIN SLAB TO OUTSIDE WALL.
- SEE 1/S3.2 FOR TRASH ENCLOSURE. SEE ARCHITECTURAL SITE PLAN FOR LOCATION.

**LEGEND:**

- # TILT-UP CONCRETE WALL. FOR REINFORCING REQUIREMENTS AND JOINT LOCATIONS, SEE TILT-UP CONCRETE PANEL ELEVATIONS ON SHEETS S5.1 THRU S5.6.
- PANEL JOINT BETWEEN TILT-UP CONCRETE WALL PANELS.

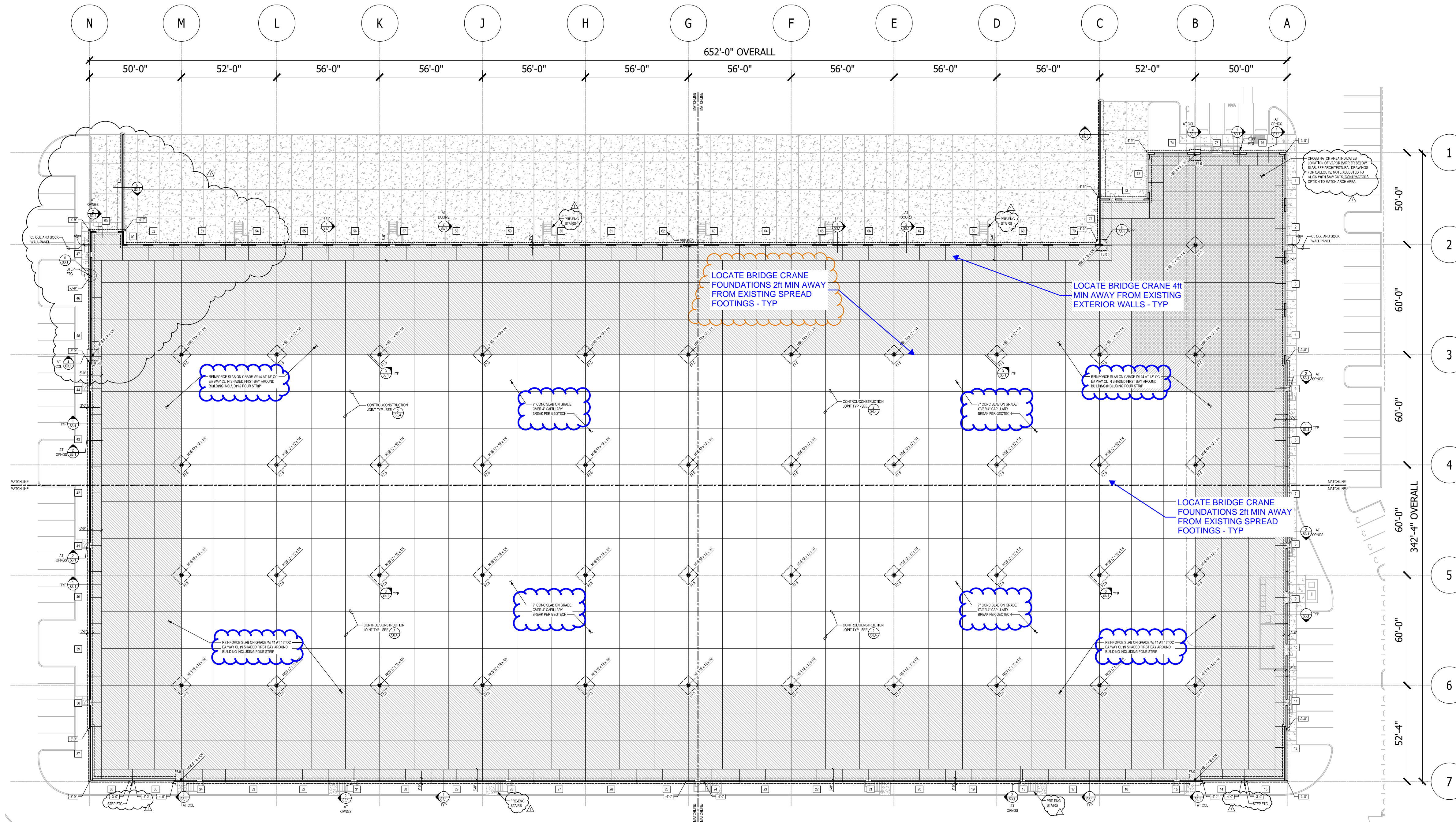

**OVERALL FOUNDATION PLAN**

NTS



FOOTING SCHEDULE			
MARK	SIZE	REINFORCING	REMARKS
F6.0	6'-0" x 6'-0" x 1'-2"	(7) #5 EACH WAY AT BOTTOM OF FOOTING	
F7.5	7'-6" x 7'-6" x 1'-4"	(7) #6 EACH WAY AT BOTTOM OF FOOTING	

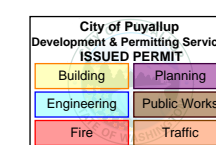

**FOOTINGS SCHEDULE NOTES:**

- TOP OF FOOTING ELEVATION = -1'-0" UNLESS NOTED OTHERWISE ON PLAN.
- FOOTING DESIGN BASED ON 2500 PSF ALLOWABLE SOIL BEARING PRESSURE.
- EQUALLY SPACE REINFORCING IN EACH DIRECTION.
- PROVIDE 3" CLEAR TO REINFORCING AT BOTTOM OF FOOTING.

PRCTI20221709

SEE SHEET SHEET 2 FOR ENGINEER OF RECORD SEAL FOR ENCLOSED PLANS.

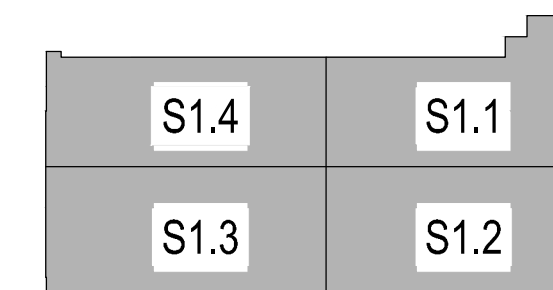

KEY PLAN



**PANATTONI**  
DEVELOPMENT  
1821 DOCK ST SUITE 100  
TACOMA, WA 98402

PUYALLUP CORPORATE CENTER

EAST MAIN AVENUE AT LINDEN LANE  
PUYALLUP, WASHINGTON

Description:	No:	Date:
PERMIT SUBMITTAL		04/03/2020
PRICING SET		07/21/2020
PERMIT RESUBMITTAL		08/24/2020



TACOMA • SEATTLE • SPOKANE • TRI-CITIES  
2215 North 30th Street, Suite 300 Tacoma, WA 98403  
253.383.2422 TEL 253.383.2572 FAX www.ahbl.com WEB

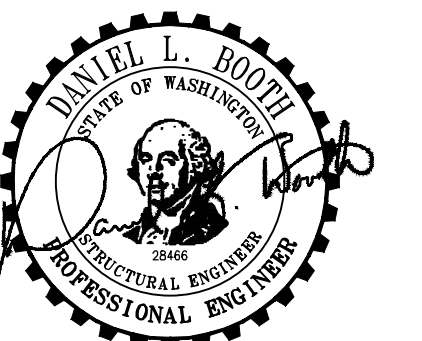

NOTICE:  
ATTENTION OF THE DOCUMENT SHALL BE ADVISED THAT THE PROFESSIONAL SEAL AND SIGNATURE OF THE ENGINEER OF RECORD DOES NOT WARRANT FROM THE ENGINEER'S LIABILITY FOR THE PROJECT. THE ENGINEER'S LIABILITY FOR THE PROJECT IS LIMITED TO THE PROJECT FOR WHICH HE OR SHE IS REGISTERED AND LICENSED TO PROVIDE PROFESSIONAL ENGINEERING SERVICES.

**OVERALL FOUNDATION PLAN**

Proj. No: 2190390.20 Reviewed By: LAH/CLR

**S1.0**

**CUSTOMER: KONECRANES-**  
**SITE ADDRESS: RED DOT 495 ANDOVER PARK E, SEATTLE, WA 98188**  
**SCOPE OF WORK: 10 TON BRIDGE CRANE RUNWAY EXTENSION**  
**GENERAL NOTES:**

- GENERAL
  - ALL BUILDING MATERIALS AND CONSTRUCTION SHALL CONFORM TO THE IBC 2015, CURRENT WA BUILDING CODES INCLUDING ALL CURRENT AMENDMENTS AND OTHER LOCAL CODES AND SAFETY LAWS CURRENTLY IN FORCE.
- MATERIALS
  - STRUCTURAL STEEL SHALL CONFORM TO THE FOLLOWING ASTM SPECIFICATIONS UNLESS NOTED OTHERWISE
 

CHANNELS, FLAT BAR AND ANGLES	A-36	<b>THE APPROVED CONSTRUCTION PLANS, DOCUMENTS AND ALL ENGINEERING MUST BE POSTED ON THE JOB AT ALL INSPECTIONS IN A VISIBLE AND READILY ACCESSIBLE LOCATION.</b>  <b>FULL SIZED LEDGIBLE COLOR PLANS ARE REQUIRED TO BE PROVIDED BY THE PERMITEE ON SITE FOR INSPECTION</b>
WIDE FLANGE SHAPES	A992 (Fy=50 ksi)	
S BEAMS	A-36	
PLATES	A-36	
BOLTS	A325	
NUTS	A563	
FLAT WASHERS	ASTM F 435	
ANCHOR BOLTS	F1554-Grade 36 & GRADE 55	
TUBING ASTM	A-500	
- EPOXY
  - HILTI HIT-HY 200
  - HILTI RE-500 SD (ICC-ESR 2322)
- GROUT
  - HILTI CB-G MG GROUT OR SIMILAR NON SHRINK GROUT
- ALL CONCRETE SHALL BE NORMAL WEIGHT CONCRETE WITH MINIMUM STRENGTH OF  $f_c=4000$  PSI AT 28 DAYS. SPECIAL INSPECTION IS REQUIRED AS PER SECTION 1704 & 1705 IBC 2015
 

CEMENT SHALL BE TYPE I OR TYPE II CONFORMING TO ASTM C-150
- REINFORCING STEEL
  - ALL REINFORCING DEFORMED BARS NO 5 AND LARGER SHALL CONFORM TO ASTM A615, GRADE 60 AND NO. 4 AND SMALLER SHALL CONFORM TO ASTM A615 GRADE 40
  - MINIMUM CONCRETE COVER BETWEEN REINFORCING BARS AND FACE OF CONCRETE SHALL BE AS FOLLOWS:
 

CONCRETE CAST AGAINST EARTH	3"
FORMED CONCRETE SURFACE EXPOSED TO WEATHER OR EARTH	2"
  - REINFORCING BARS SHALL LAP 30 DIAMETERS MINIMUM AT SPLICE INLESS OTHERWISE SHOWN
- ANCHOR ROD NUT INSTALLATION. ANCHOR ROD NUTS SHALL BE SNUG TIGHT. SEE 14-10 AISC ANCHOR ROD NUT INSTALLATION
- SUBGRADE AND SUBBASE
  - COMPACT TOP 6" OF EXPOSED NATURAL GRADE AND ALL REQUIRED FILL TO 90% MAXIMUM DENSITY
  - ALL EXISTING NONCOMPACTED FILL SOILS AND DISTURBED NATURAL SOILS ARE TO BE EXCAVATED AND PROPERLY COMPACT
  - A FOUNDATION INVESTIGATION REPORT IS REQUIRED FOR ORGANIC CLAY. ALLOWABLE SOIL BEARING PRESSURE IS ASSUMED TO BE 1500PSF. ASSUMED ALLOWABLE SOIL BEARING PRESSURE MUST BE VERIFIED BY A QUALIFIED SOILS ENGINEER OR APPROVED BY THE BUILDING OFFICIAL. IF SOILS ARE FOUND TO BE OTHER THAN AS ASSUMED, NOTIFY RAMSEY MACHINE SERVICES OF POSSIBLE FOUNDATION REDESIGN.
 

2,500 PSF PER AS-BUILT / RECORD DRAWINGS
- FIELD WELDING SHALL BE DONE BY A CERTIFIED WELDER USING LOW HYDROGEN ELECTRODES. WELDING ELECTRODES SHALL BE TYPE E70XX
- ALL BOLTED CONNECTIONS SHALL BE SNUG TIGHT SEE SECTION 8.1 RESEARCH COUNCIL ON STRUCTURAL CONNECTIONS
- CRANE RUNWAYS TO BE LOAD TESTED AT 125% OF RATED CAPACITY

INDEX	
	NOTES
S1	PLAN VIEW
S2	PLAN VIEW
S3	SECTION ELEVATION
S4	END ELEVATION
SD1	DETAILS
SD2	DETAILS
SD3	DETAILS

LOADS / SECTION 1603.1.5 SPECIAL LOADS	
SEISMIC IMPORTANCE FACTOR	I
SEISMIC DESIGN CATEGORY	D
BASIC SEISMIC FORCE RESISTING SYSTEM	LONGITUDINAL FORCES RESISTED BY KNEE BRACES LATERAL DIRECTION INVERTED PENDULUM
	DESIGN BASE SHEAR
LONGITUDINAL DIRECTION	7.17K
LATERAL DIRECTION	2.03K
SEISMIC MODIFICATION COEFFICIENT	LONGITUDINAL DIRECTION R=1 LATERAL DIRECTION R=2
ANALYSIS PROCEDURE	EQUIVALENT LATERAL FORCE ANALYSIS (ASD)
SEISMIC RISK CATEGORY	II 1.006
SITE CLASS D	$S_{ds} = .967$ $S_{d1} = .541$
SOIL BEARING	1500 PSF (SEE NOTE ABOVE) 2,500 PSF PER AS-BUILT / RECORD DRAWINGS
DESIGN BASE SHEAR	LATERALLY=3.959 LONGITUDINALLY=7.039

7/27/2016 Design Maps Summary Report  
**USGS Design Maps Summary Report**  
 User-Specified Input  
 Report Title Red Dot  
 Wed July 27, 2016 23:46:05 UTC  
 Building Code Reference Document 2012/2015 International Building Code (which utilizes USGS hazard data available in 2008)  
 Site Coordinates 47.44617°N, 122.27164°W  
 Site Soil Classification Site Class D - "Stiff Soil"  
 Risk Category I/II/III

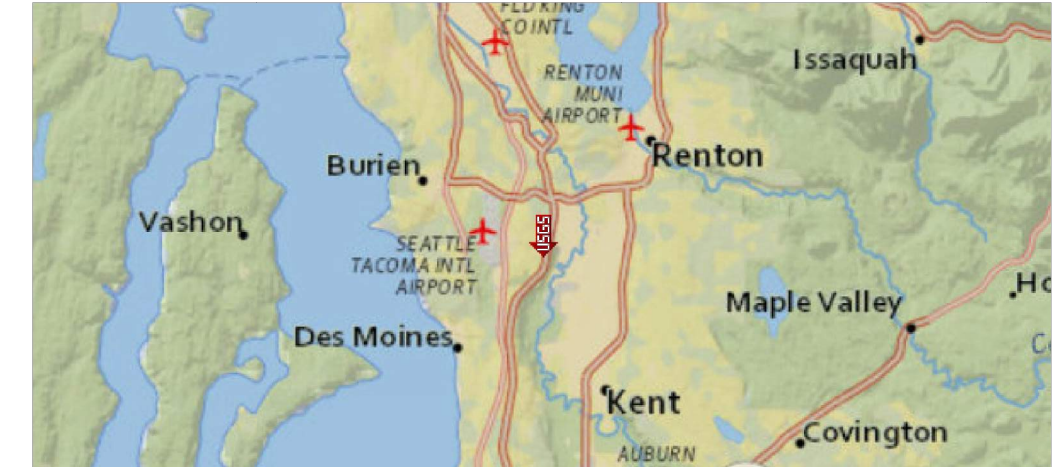

**USGS-Provided Output**  
 $S_s = 1.450$  g  $S_{MS} = 1.450$  g  $S_{DS} = 0.967$  g  
 $S_1 = 0.541$  g  $S_{M1} = 0.811$  g  $S_{D1} = 0.541$  g

For information on how the  $S_s$  and  $S_1$  values above have been calculated from probabilistic (risk-targeted) and deterministic ground motions in the direction of maximum horizontal response, please return to the application and select the "2009 NEHRP" building code reference document.

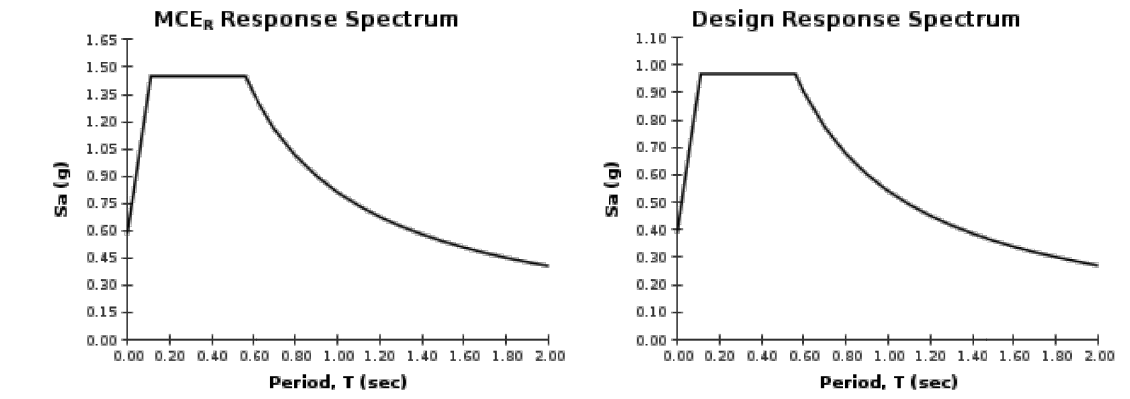

Although this information is a product of the U.S. Geological Survey, we provide no warranty, expressed or implied, as to the accuracy of the data contained therein. This tool is not a substitute for technical subject-matter knowledge.

<http://ehp1-earthquake.cr.usgs.gov/designmaps/us/summary.php?template=minimal&latitude=47.44616665744004&longitude=-122.27163884468315&siteclass=...> 1/1

**SPECIAL INSPECTIONS (IF APPLICABLE)**

MATERIALS	PERIODIC INSPECTION	CONTINUOUS INSPECTION	REFERENCE
FIELD WELDING	Fillet Welds < 5/16"	xx ALL OTHER WELDS	
HIGH STRENGTH BOLTS	XX		
INSPECT CONCRETE PLACEMENT FOR PROPER APPLICATION TECHNIQUES		XX	1908.6, 1908.7, 1908.8
REINFORCEMENT AND VERIFYING PLACEMENT	XX		1908.4
VERIFY MAINTENANCE OF SPECIFIED CURING TEMPERATURE AND TECHNIQUES		XX	1908.9
INSPECT FORMWORK	XX		ACI 318
VERIFY USE OF DESIGN MIX	XX		ACI 318 CHAPTER 19
PRIOR TO PLACEMENT FABRICATE SPECIMENS FOR STRENGTH TEST. PERFORM SLUMP AND AIR TEST AND DETERMINE TEMPERATURE OF CONCRETE		XX	1908.10

LOADS / SECTION 1603.1.8 SPECIAL LOADS	
MAX WHEEL LOADS (STATIC)	= 12.387K
MAX WHEEL LOADS (W/ IMPACT)	= 13.46K
VERTICAL IMPACT FACTOR	=10%
LATERAL LOADS	= 1.07K
LONGITUDINAL LOADS	= 2.69K
BRIDGE CRANE WGT.	=6.611 K
TROLLEY WGT.	= 1.47K

TABLE 1.4.1-1

ITEM	FIGURE	OVERALL TOLERANCE	MAXIMUM RATE OF CHANGE
CRANE SPAN (L) MEASURED AT CRANE WHEEL CONTACT SURFACE		$L \leq 50'$ $A = 3/8"$ $L > 50' \leq 100'$ $A = 1/4"$ $L > 100'$ $A = 3/16"$	1/4" IN 20'-0"
STRAIGHTNESS (B)		$B = 3/8"$	1/4" IN 20'-0"
ELEVATION (C)		$C = 3/8"$	1/4" IN 20'-0"
TOP RUNNING TRANSVERSE RAIL TO RAIL ELEVATION (D)		$L \leq 50'$ $D = \pm 3/16"$ $L > 50' \leq 100'$ $D = \pm 1/4"$ $L > 100'$ $D = \pm 3/8"$	N/A
TRANSVERSE GIRDER TO GIRDER ELEVATION UNDER RUNNING (D)			

DESIGNED: K.L. RAMSEY	NO.	DATE
DRAWN:		
CHECKED:		
DATE: 3-26-19		

DRAWINGS PREPARED FOR: **KONECRANES - RED DOT SEATTLE, WA**  
 DRAWINGS PREPARED BY: **RAMSEY MACHINE SERVICES, INC.**  
 22845 SAVI RANCH PARKWAY, YORBA LINDA, CA 92887 CSLB 828496-LA FABRICATOR #2040



PROJECT: 8662  
 SHEET  
**1**

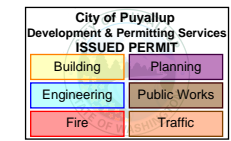

SEE SHEET SHEET 2 FOR ENGINEER OF  
RECORD SEAL FOR ENCLOSED PLANS.

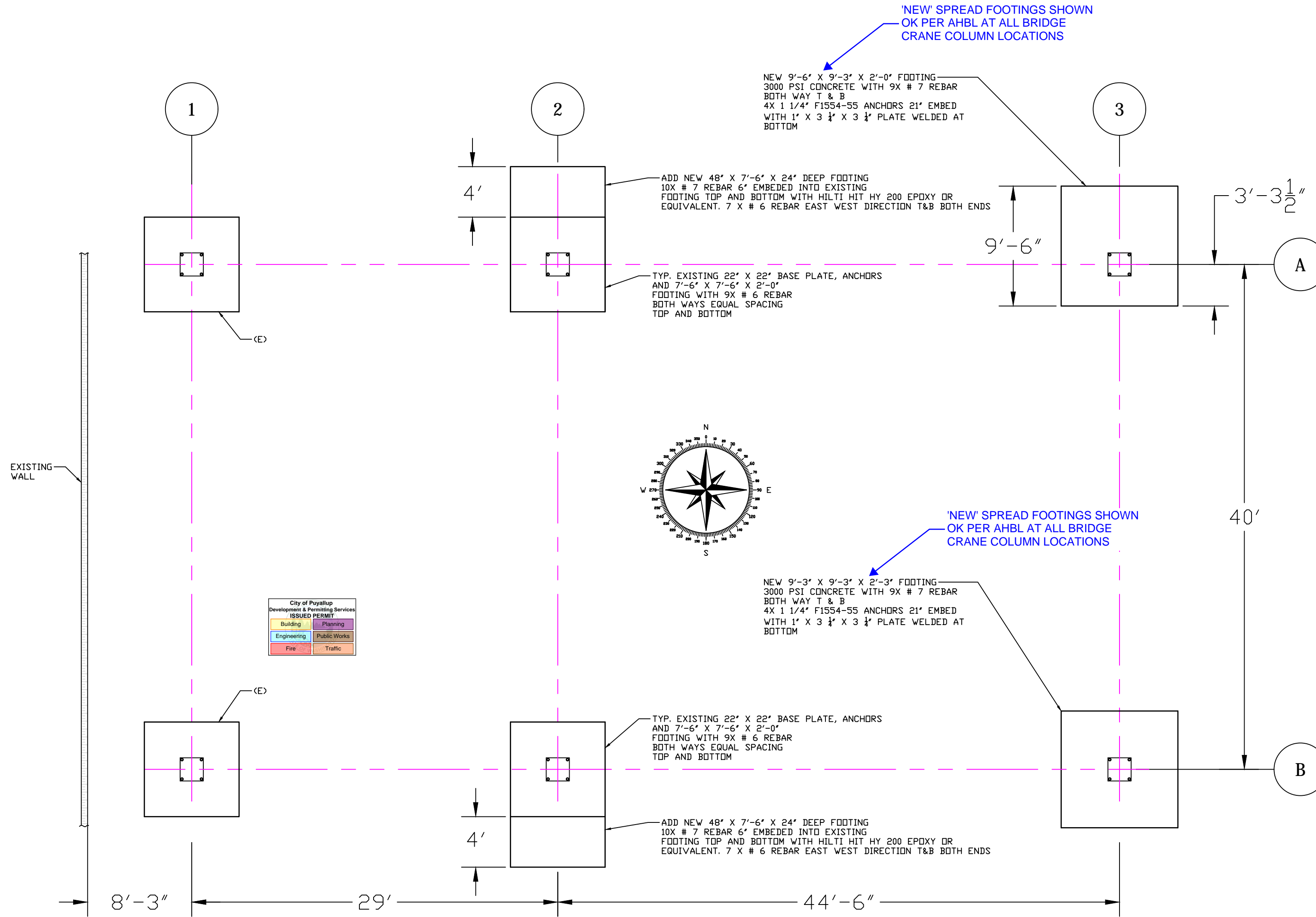

1 PLAN VIEW

SCALE 1:1

10 TON BRIDGE CRANE RUNWAY			
DESIGNED BY	K.L. RAMSEY	NO.	DATE
DRAWN BY			
CHECKED BY			
DATE	3-26-19		

DESIGNED BY	K.L. RAMSEY
DRAWN BY	
CHECKED BY	
DATE	3-26-19

DRAWINGS PREPARED FOR: **KONECRANES - RED DOT**  
SEATTLE, WA

DRAWINGS PREPARED BY: **RAMSEY MACHINE SERVICES, INC.**  
22845 SAVI RANCH, YORBA LINDA, CA 92887 CSLB 828496 LA FABRICATOR 2040



PROJECT: 8662

SHEET  
**S1**

SEE SHEET SHEET 2 FOR ENGINEER OF  
RECORD SEAL FOR ENCLOSED PLANS.

City of Puyallup Development & Permitting Services ISSUED PERMIT	
Building	Planning
Engineering	Public Works
Fire	Traffic

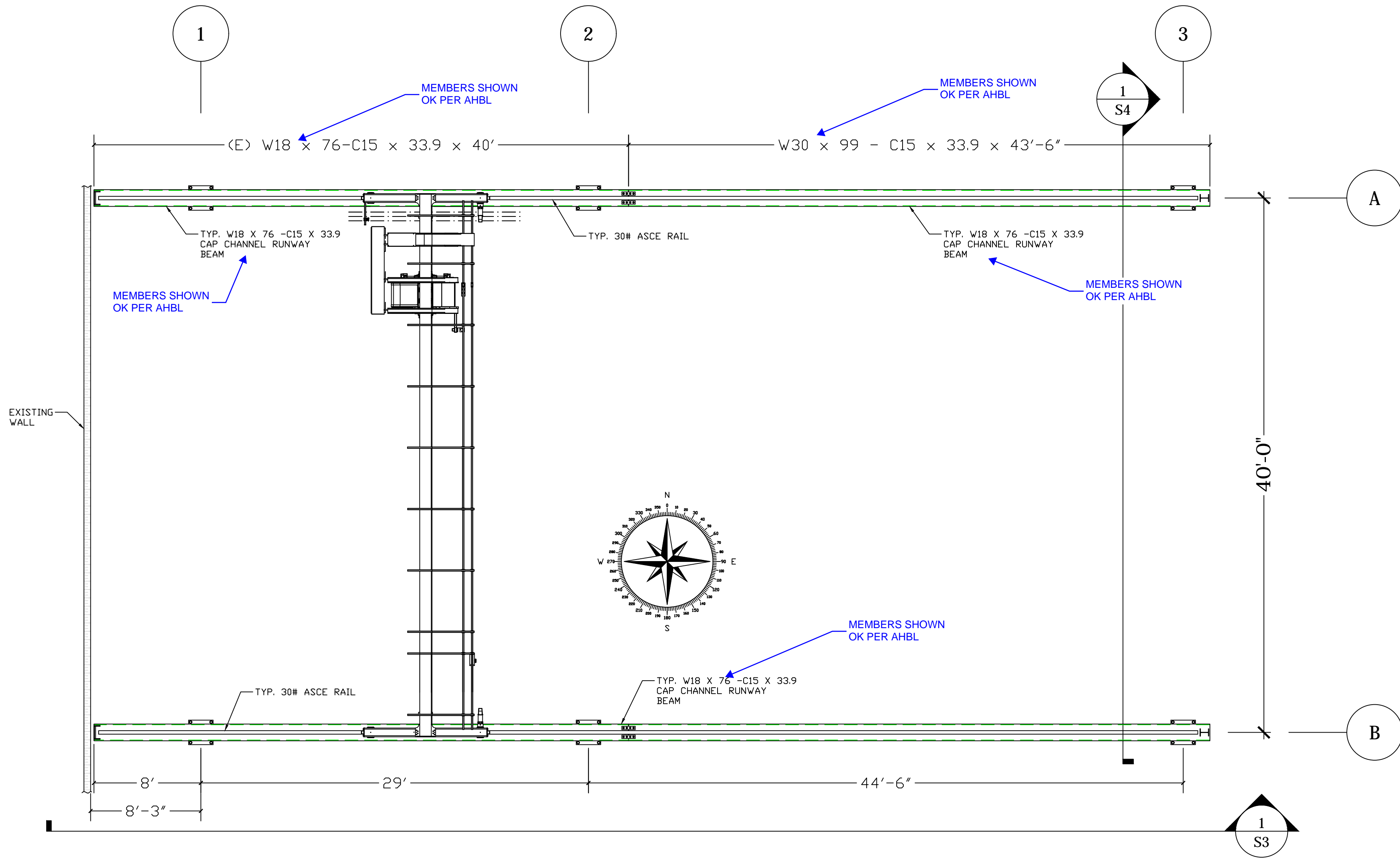

# 1 PLAN VIEW FRAMING

SCALE 1:1

<b>10 TON BRIDGE CRANE RUNWAY</b>	
DESIGNED: K.L. RAMSEY	NO.
DRAWN:	DATE
CHECKED:	3-26-19
DATE:	
DRAWINGS PREPARED FOR: <b>KONECRANES - RED DOT</b> SEATTLE, WA	
DRAWINGS PREPARED BY: <b>RAMSEY MACHINE SERVICES, INC.</b> 22845 SAVI RANCH, YORBA LINDA, CA 92887 CSLB 828496 LA FABRICATOR 2040	
PROJECT: 8662	
SHEET	
<b>S2</b>	



SEE SHEET SHEET 2 FOR ENGINEER OF  
RECORD SEAL FOR ENCLOSED PLANS.

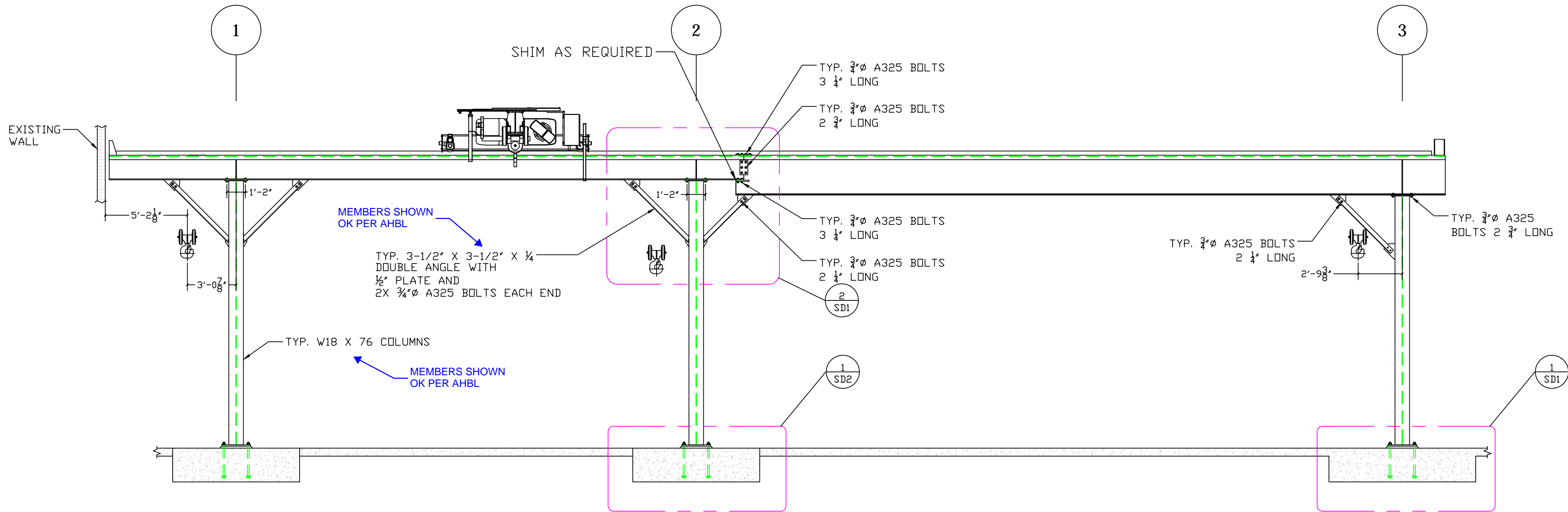
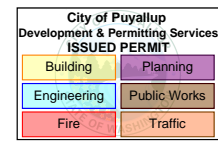

1 SECTION ELEVATION

SCALE 1:1

BOLTS				
QTY	DIAMETER	LENGTH	GRADE	
24	0'-0 3/4"	0'-3 1/4"	A-325	
20	0'-0 3/4"	0'-2 3/4"	A-325	
16	0'-0 3/4"	0'-2 1/4"	A-325	

10 TON BRIDGE CRANE RUNWAY			
DESIGNED: K.L. RAMSEY			
DRAWN:			
CHECKED:			
DATE: 3-26-19			
		NO.	DATE

DRAWINGS PREPARED FOR: **KONECRANES - RED DOT**  
SEATTLE, WA

DRAWINGS PREPARED BY: **RAMSEY MACHINE SERVICES, INC.**  
22845 SAVI RANCH, YORBA LINDA, CA 92887 CSLB 828496 LA FABRICATOR 2040



SHEET  
**S3**

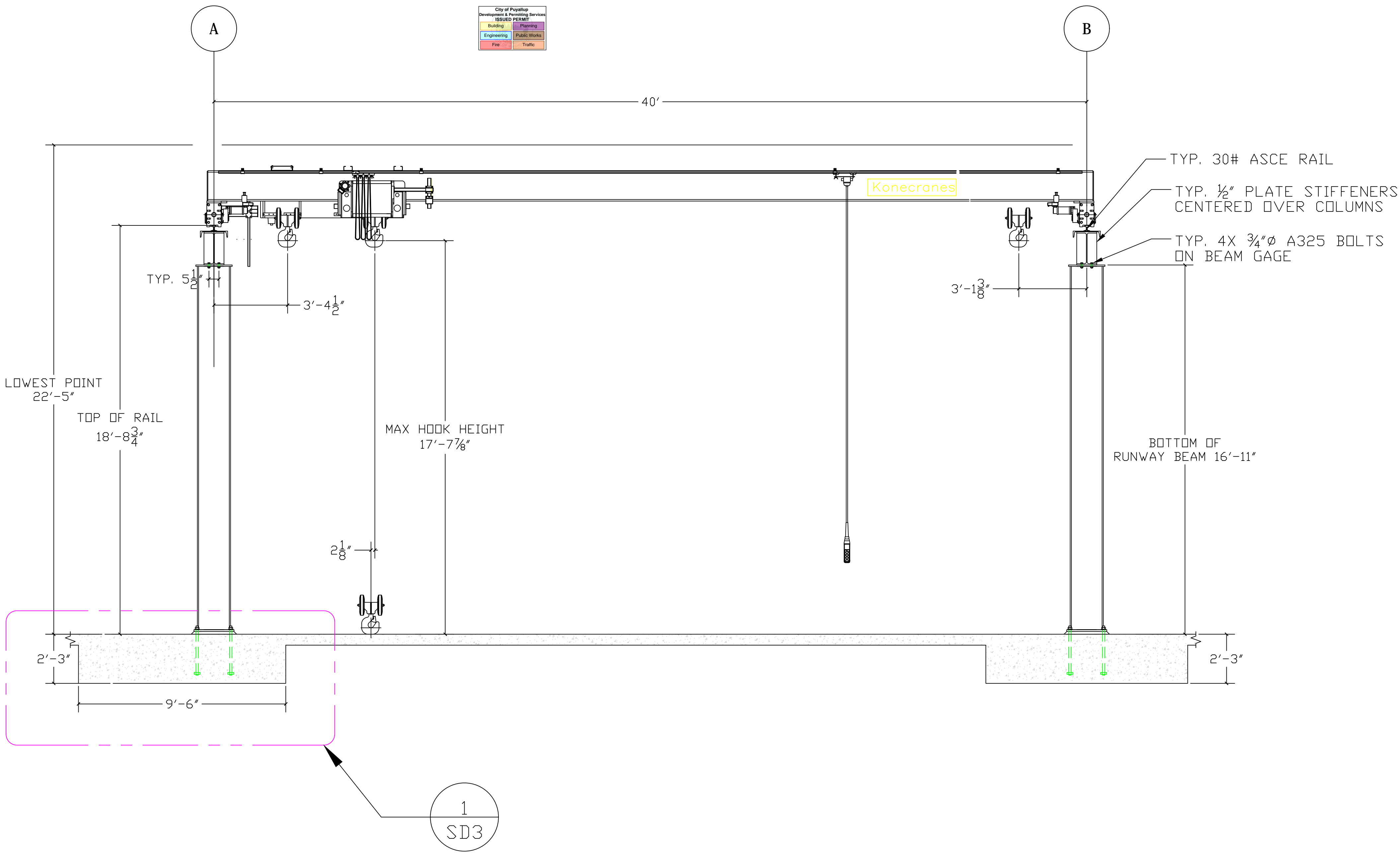

1 SECTION ELEVATION

SCALE 1:1

DESIGNED: K.L. RAMSEY	NO.	DATE
DRAWN:		
CHECKED:		
DATE: 3-26-19		
DRAWINGS PREPARED FOR: KONECRANES - RED DOT SEATTLE, WA		
DRAWINGS PREPARED BY: RAMSEY MACHINE SERVICES, INC. 22845 SAVI RANCH, YORBA LINDA, CA 92887 CSLB 828496 LA FABRICATOR 2040		
PROJECT: 8662		
SHEET		
S4		

SEE SHEET SHEET 2 FOR ENGINEER OF  
RECORD SEAL FOR ENCLOSED PLANS.

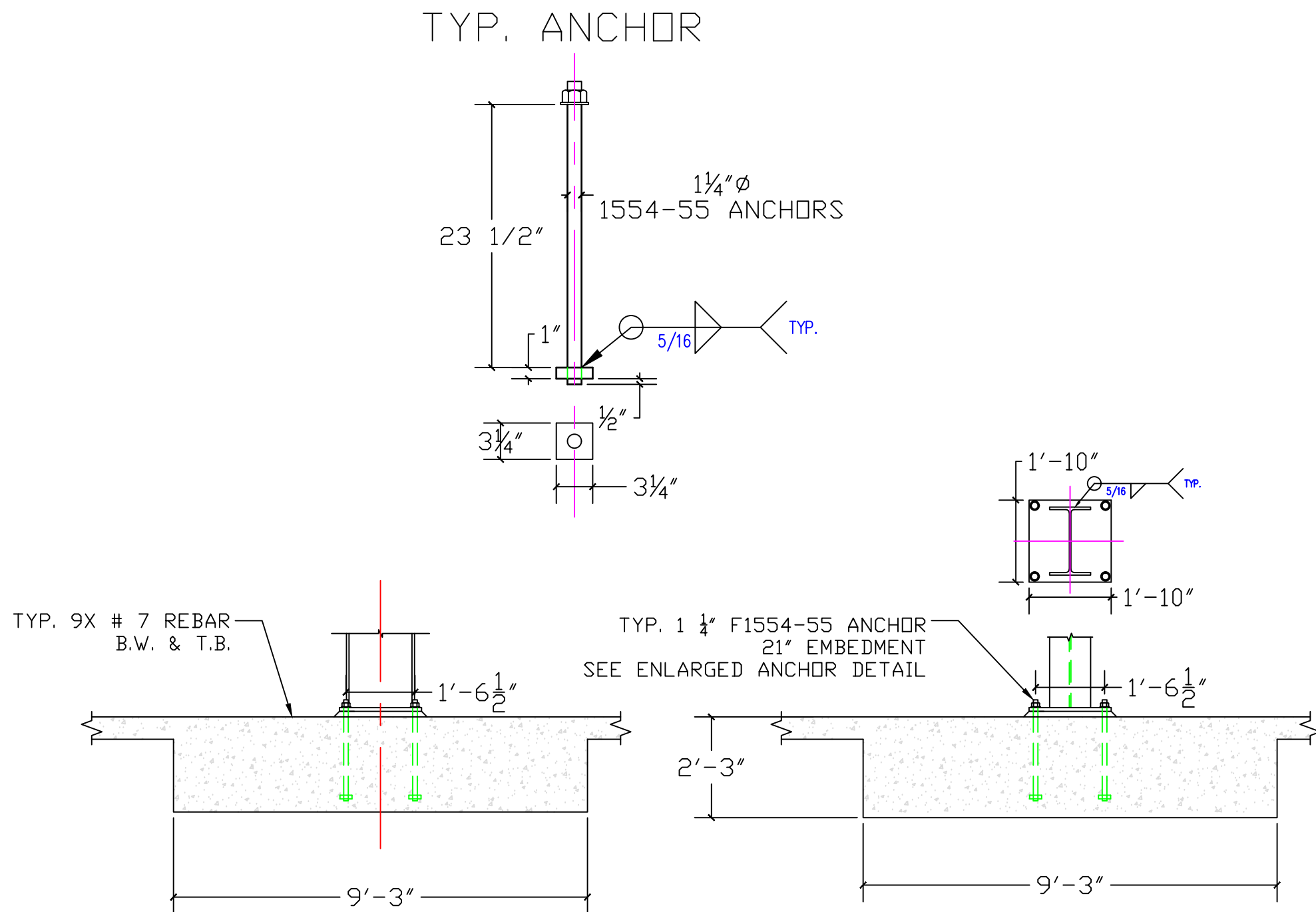
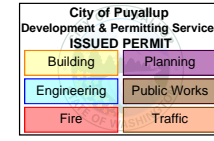

1 FOOTING DETAIL GRID LINE 3

SCALE 1:1

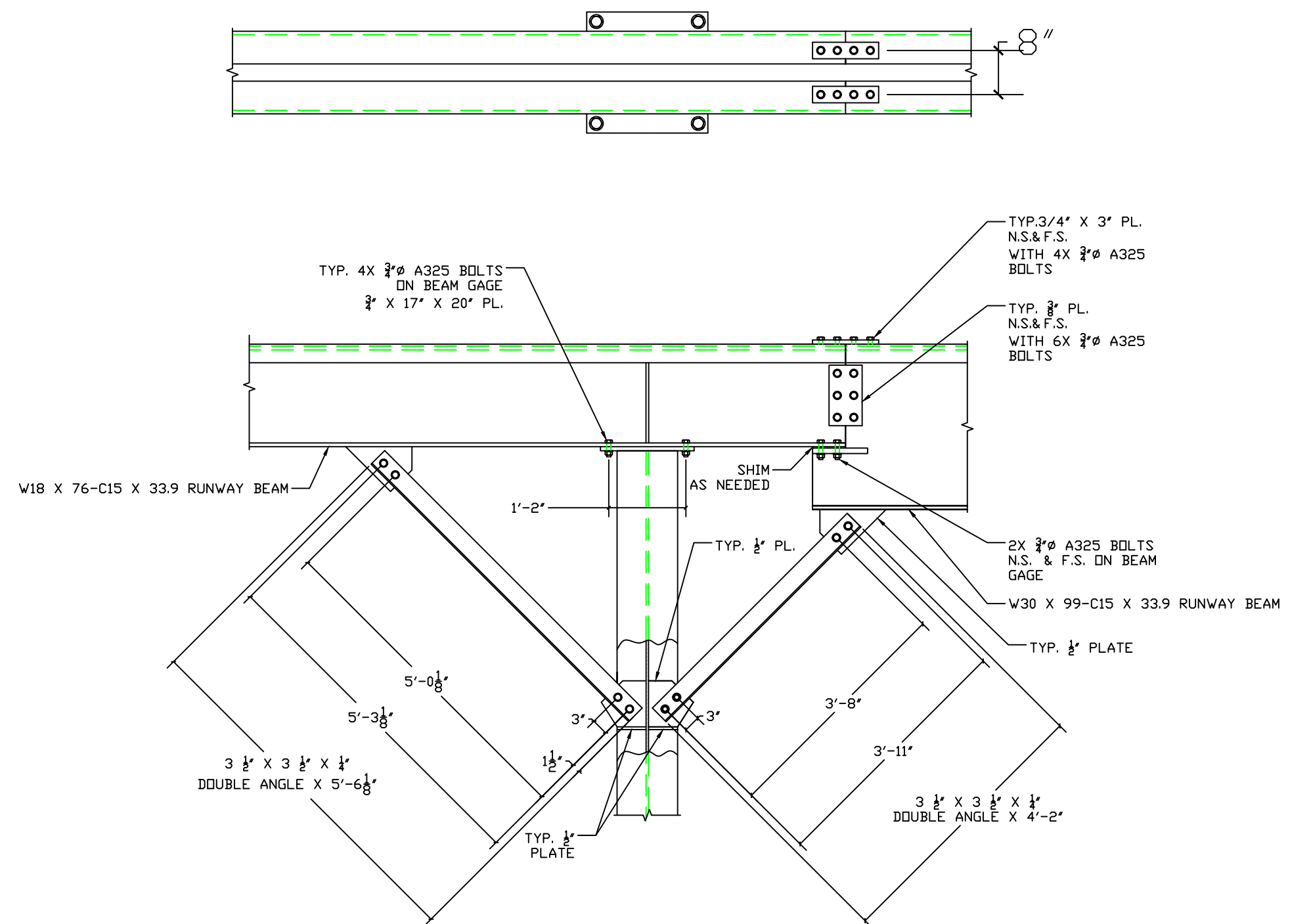

2 CONNECTION / SPLICE DETAIL

SCALE 1:1

DESIGNED: K.L. RAMSEY	NO.	DATE
DRAWN:	NO.	DATE
CHECKED:	NO.	DATE
DATE: 3-26-19	NO.	DATE

DRAWINGS PREPARED FOR: **KONECRANES - RED DOT**  
SEATTLE, WA

DRAWINGS PREPARED BY: **RAMSEY MACHINE SERVICES, INC.**  
22845 SAVI RANCH, YORBA LINDA, CA 92887 CSLB 828496 LA FABRICATOR 2040



PROJECT: 8662

SHEET  
**SD1**

SEE SHEET SHEET 2 FOR ENGINEER OF  
RECORD SEAL FOR ENCLOSED PLANS.

City of Puyallup Development & Permitting Services ISSUED PERMIT	
Building	Planning
Engineering	Public Works
Fire	Traffic

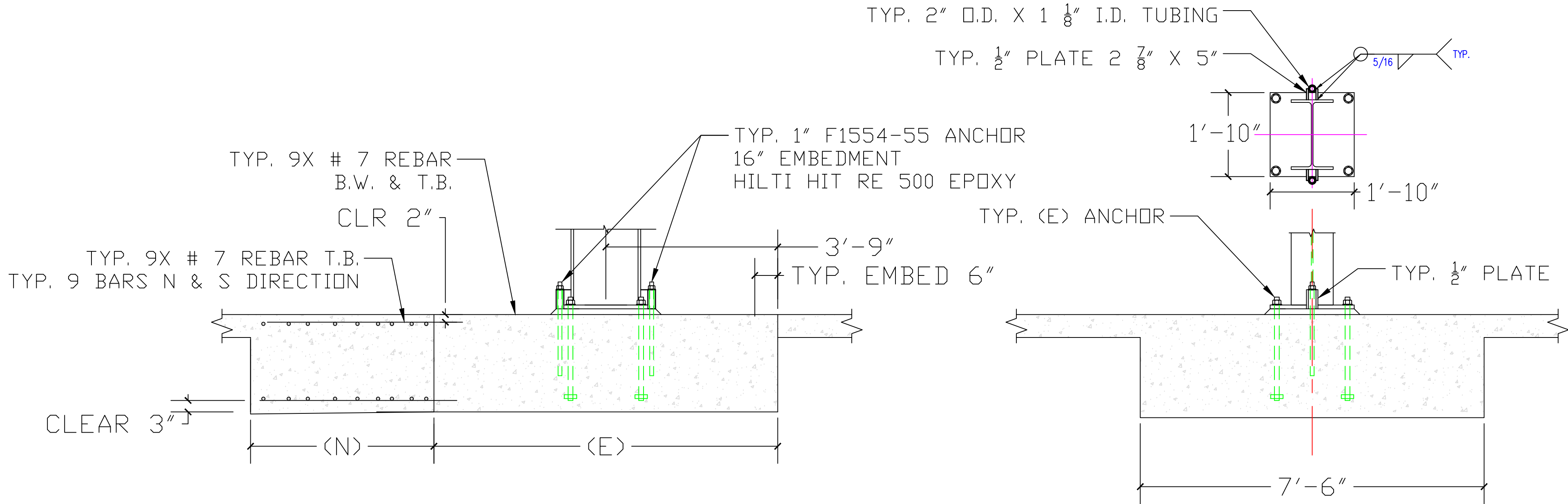

**1** FOOTING DETAIL GRID LINE 2

SCALE 1:1

10 TON BRIDGE CRANE RUNWAY			
DESIGNED: K.L. RAMSEY	NO.	DATE	
DRAWN:			
CHECKED:			
DATE: 3-26-19			

DRAWINGS PREPARED FOR: KONECRANES - RED DOT SEATTLE, WA	
DRAWINGS PREPARED BY: RAMSEY MACHINE SERVICES, INC. 22845 SAVI RANCH, YORBA LINDA, CA 92887 CSLB 828496 LA FABRICATOR 2040	

DRAWINGS PREPARED FOR: KONECRANES - RED DOT SEATTLE, WA	
DRAWINGS PREPARED BY: RAMSEY MACHINE SERVICES, INC. 22845 SAVI RANCH, YORBA LINDA, CA 92887 CSLB 828496 LA FABRICATOR 2040	



PROJECT: 8662
SHEET
<b>SD2</b>

SEE SHEET SHEET 2 FOR ENGINEER OF  
RECORD SEAL FOR ENCLOSED PLANS.

### TYP. ANCHOR

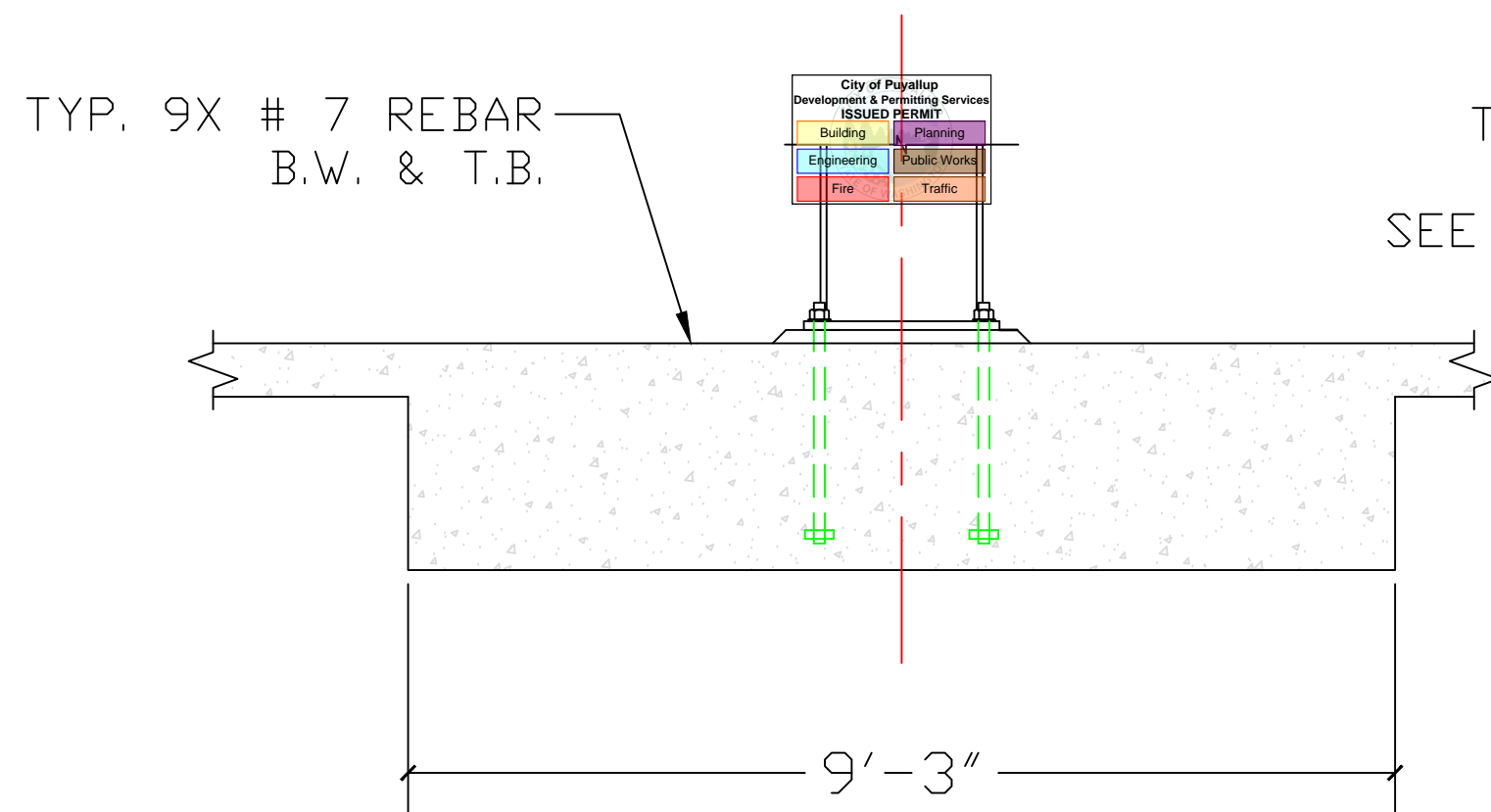
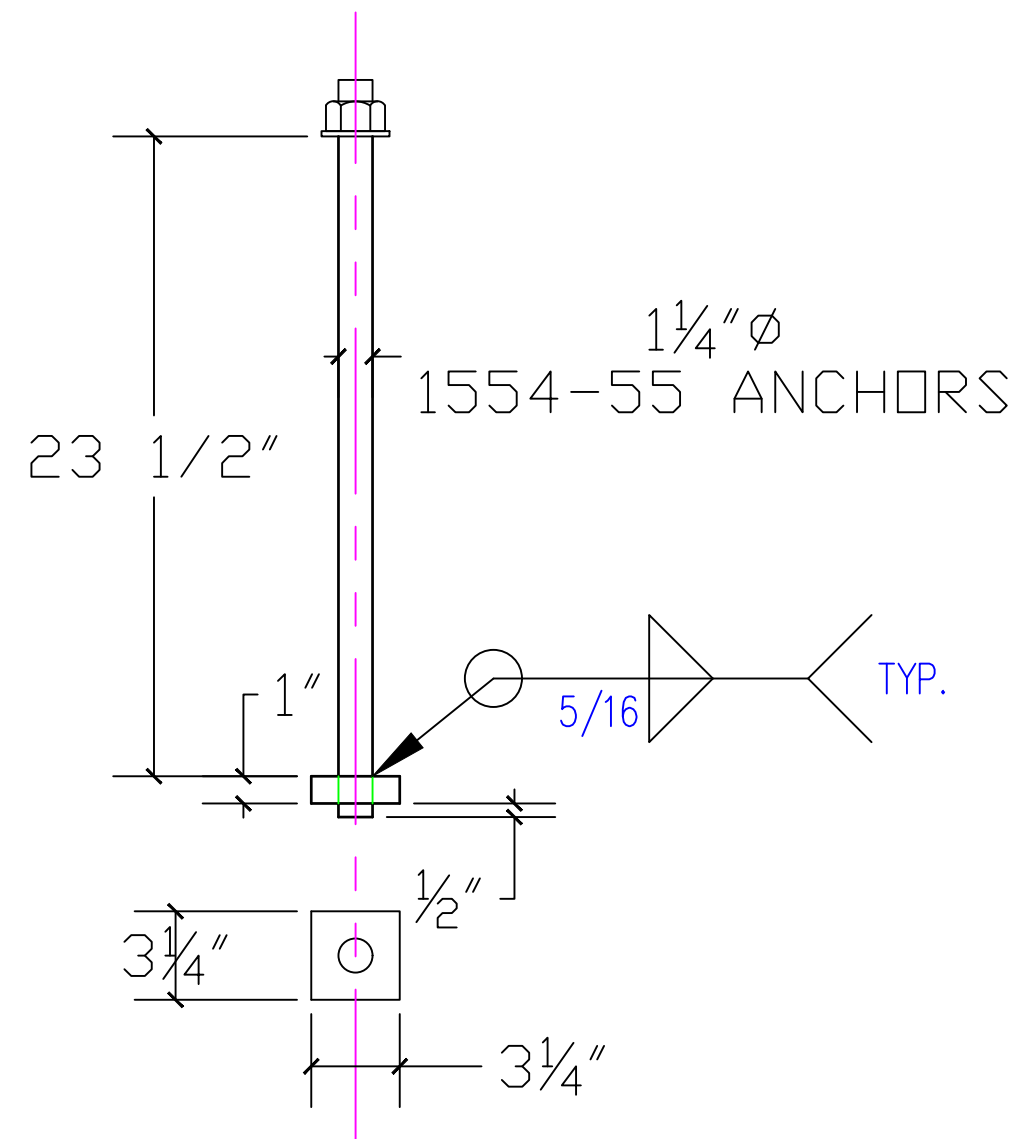

TYP. 1 1/4" F1554-55 ANCHOR  
21" EMBEDMENT  
SEE ENLARGED ANCHOR DETAIL

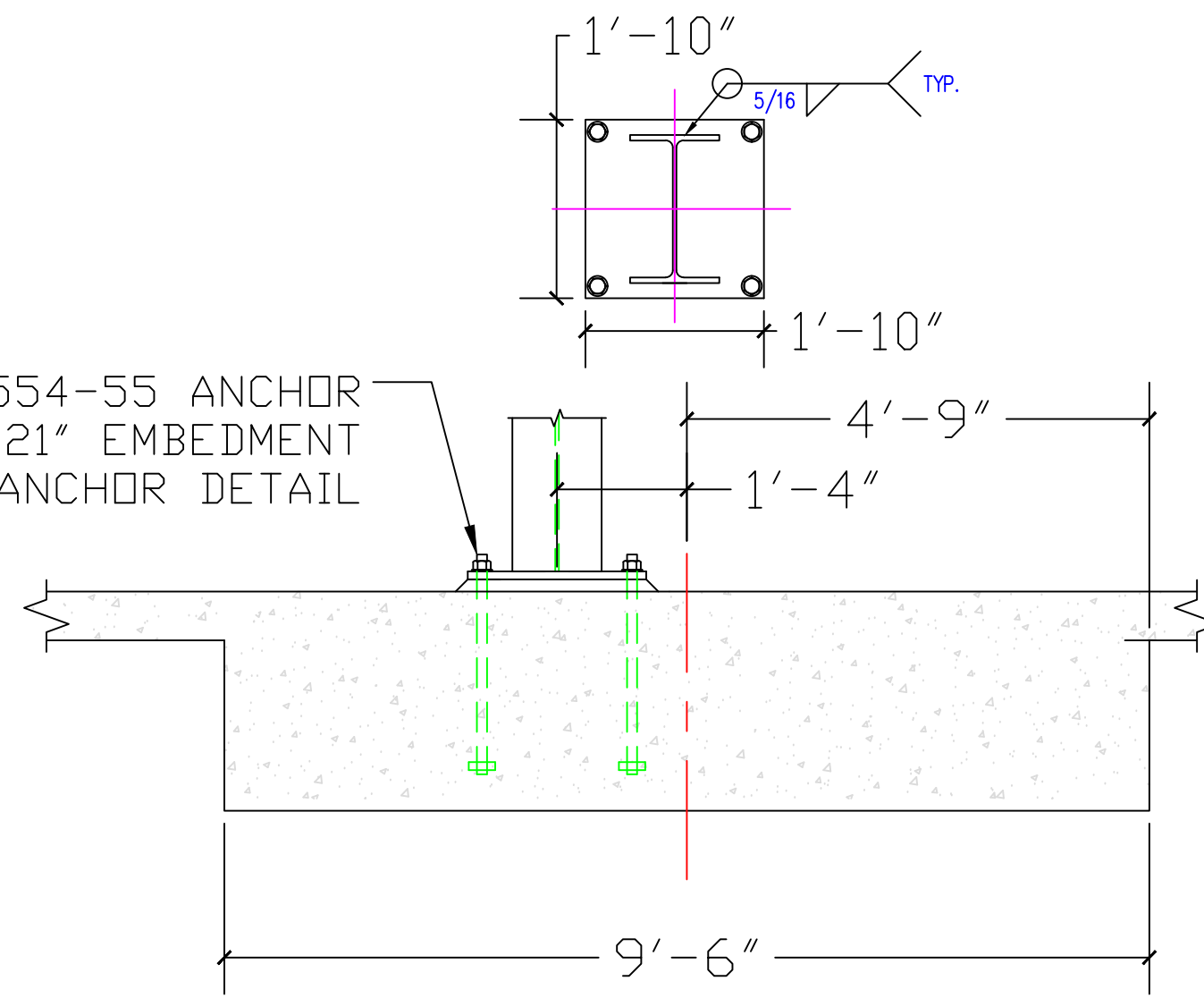

## 1 FOOTING DETAIL GRID LINE 2

SCALE 1:1

DESIGNED: K.L. RAMSEY	NO.	DATE
DRAWN:	NO.	DATE
CHECKED:	NO.	DATE
DATE: 3-26-19	NO.	DATE

10 TON BRIDGE CRANE RUNWAY
----------------------------

DRAWINGS PREPARED FOR: **KONECRANES - RED DOT**  
SEATTLE, WA

DRAWINGS PREPARED BY: **RAMSEY MACHINE SERVICES, INC.**  
22845 SAVI RANCH, YORBA LINDA, CA 92887 CSLB 828496 LA FABRICATOR 2040



PROJECT: 8662

SHEET

SD3

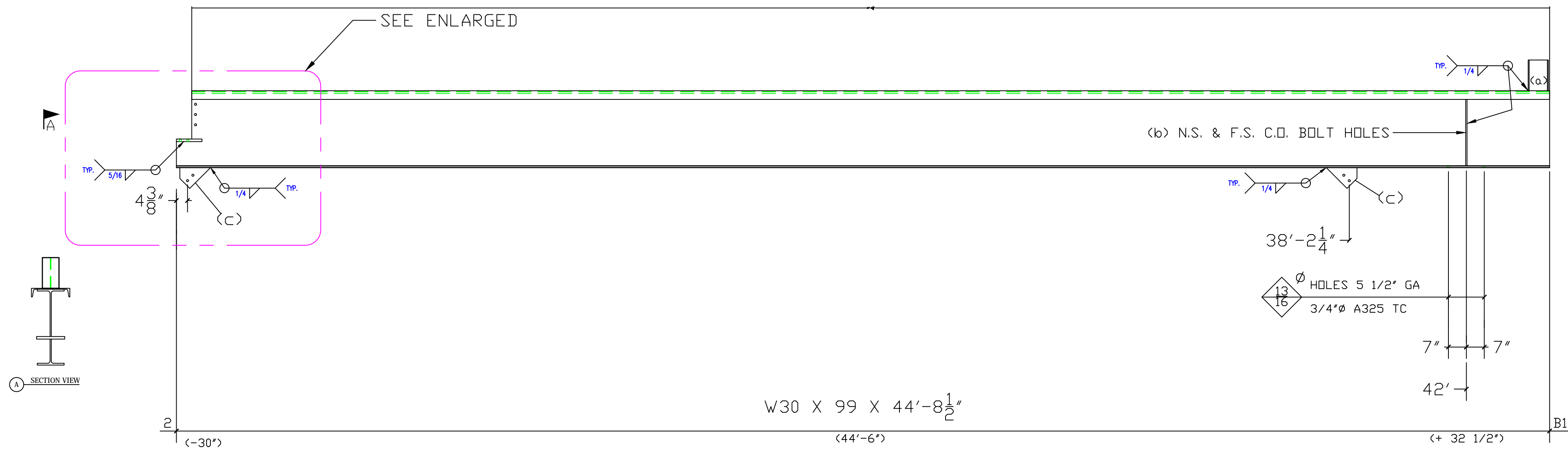

1 RUNWAY BEAM

SCALE 1:1

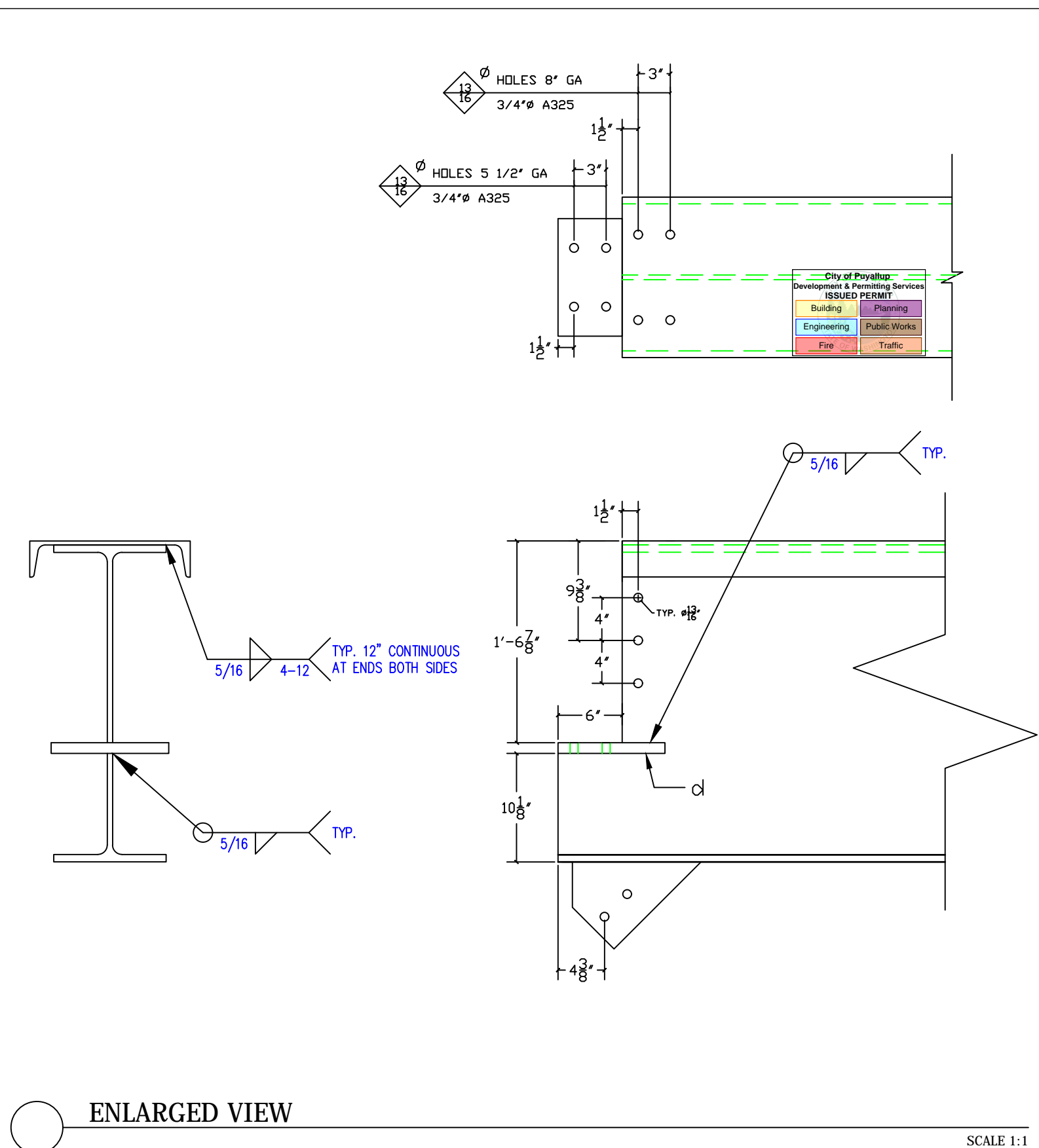

ENLARGED VIEW

SCALE 1:1

BILL of MATERIAL						
QTY	MARK	DESCRIPTION	LENGTH	REMARK	REF	WEIGHT
2		W30 X 99	44'-8 1/2"	A992		4426
2		C15 X 33.9	44'-2 1/2"	A36		1499
2	a	W8 X 24	1'-0"	A992		48
4	b	1/2" PL. X 5"	2'-5 1/8"	A36	1/P3	80
4	c	1/2" PL. X 8 1/8"	1'-0"	A36	2/P2	56
2	d	1" PL. X 10"	0'-11"	A36	1/P2	62
					TOTAL	6171

10 TON BRIDGE CRANE RUNWAY			
DESIGNED: K.L. RAMSEY	NO.	DATE	
DRAWN:			
CHECKED:			
DATE: 3-26-19			

DRAWINGS PREPARED FOR: **KONECRANES - RED DOT**  
SEATTLE, WA

DRAWINGS PREPARED BY: **RAMSEY MACHINE SERVICES, INC.**  
22845 SAVI RANCH, YORBA LINDA, CA 92887 CSLB 828496 LA FABRICATOR 2040

PROJECT: 8662

SHEET **B1**

SEE SHEET SHEET 2 FOR ENGINEER OF RECORD SEAL FOR ENCLOSED PLANS.

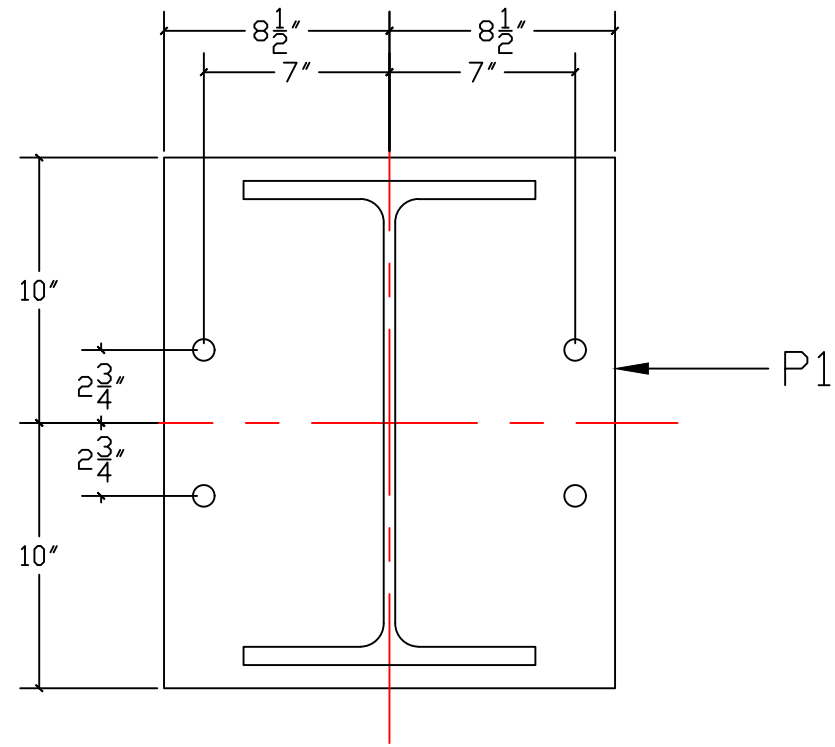
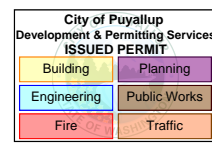

**A** SECTION VIEW  
SCALE 1:1

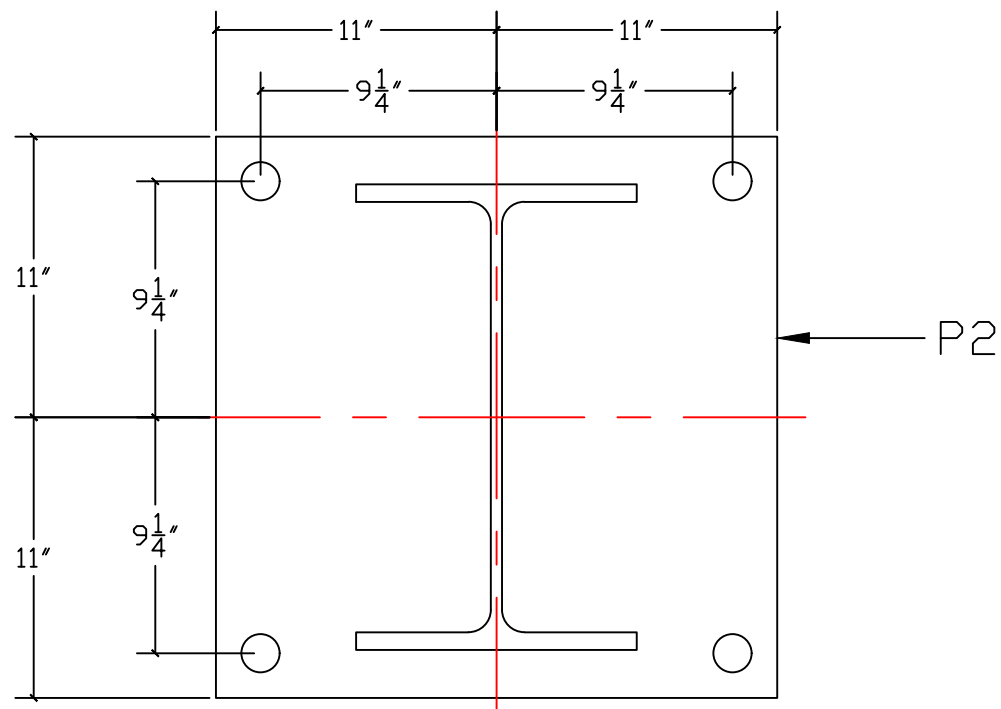

**B** SECTION VIEW  
SCALE 1:1

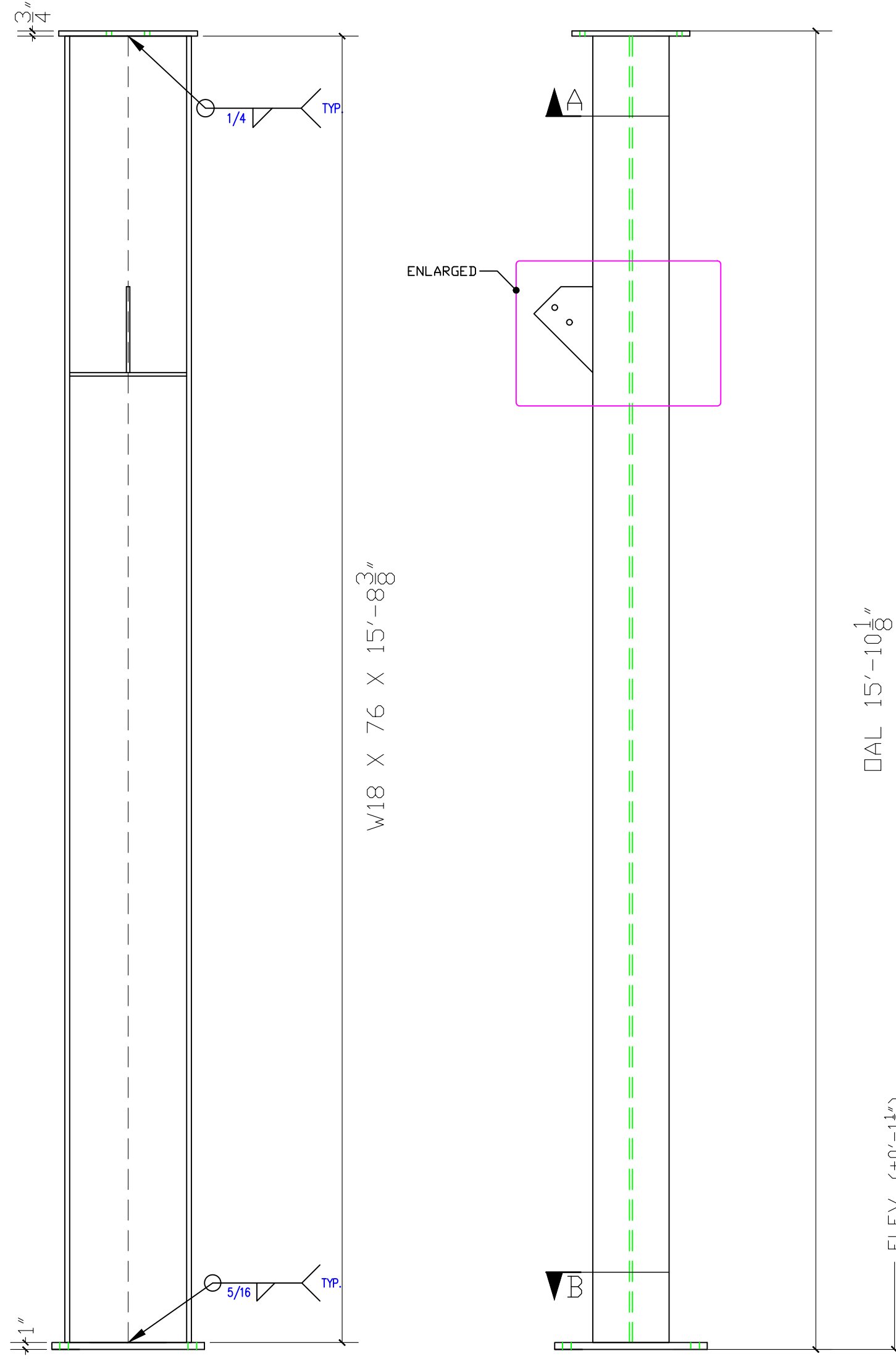

**1** COLUMN  
SCALE 1:1

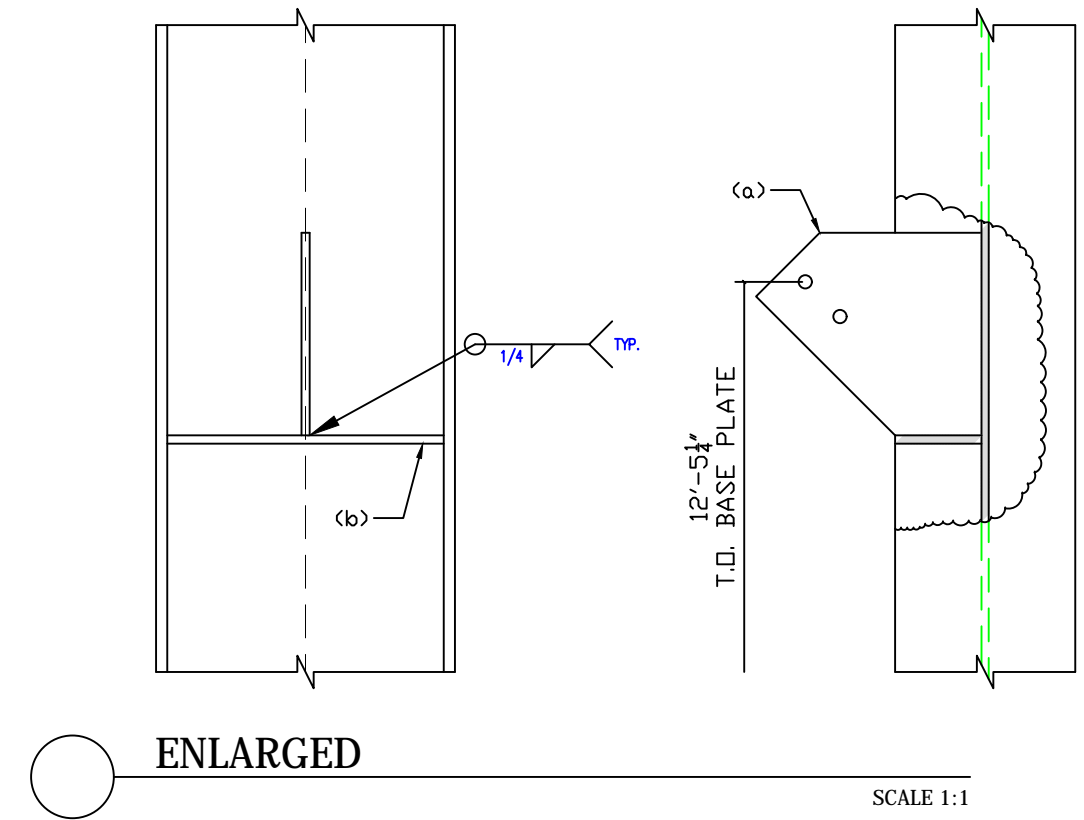

BILL of MATERIAL						
QTY	MARK	DESCRIPTION	LENGTH	REMARK	REF	WEIGHT
2	C1	W18 X 76	15'-8 3/8"	A992		1193
2	P1	3/4" PL. X 1'-5"	1'-8"	A36	1/P1	72
2	P2	1" PL. X 1'-10"	1'-10"	A572	2/P1	137
2	a	1/2" PL. X 1'-0 3/4"	1'-3 1/4"	A36	3/P2	24
2	b	1/2" PL. X 5 1/4"	1'-10 3/4"	A36	4/P2	12
					TOTAL	1438

10 TON BRIDGE CRANE RUNWAY			
DESIGNED: K.L. RAMSEY	NO.	DATE	
DRAWN:			
CHECKED:			
DATE: 3-26-19			

DRAWINGS PREPARED FOR: **KONECRANES - RED DOT**  
SEATTLE, WA

DRAWINGS PREPARED BY: **RAMSEY MACHINE SERVICES, INC.**  
22845 SAVI RANCH, YORBA LINDA, CA 92887 CSLB 828496 LA FABRICATOR 2040



PROJECT: 8662

SHEET  
**C1**

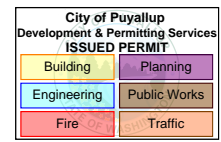
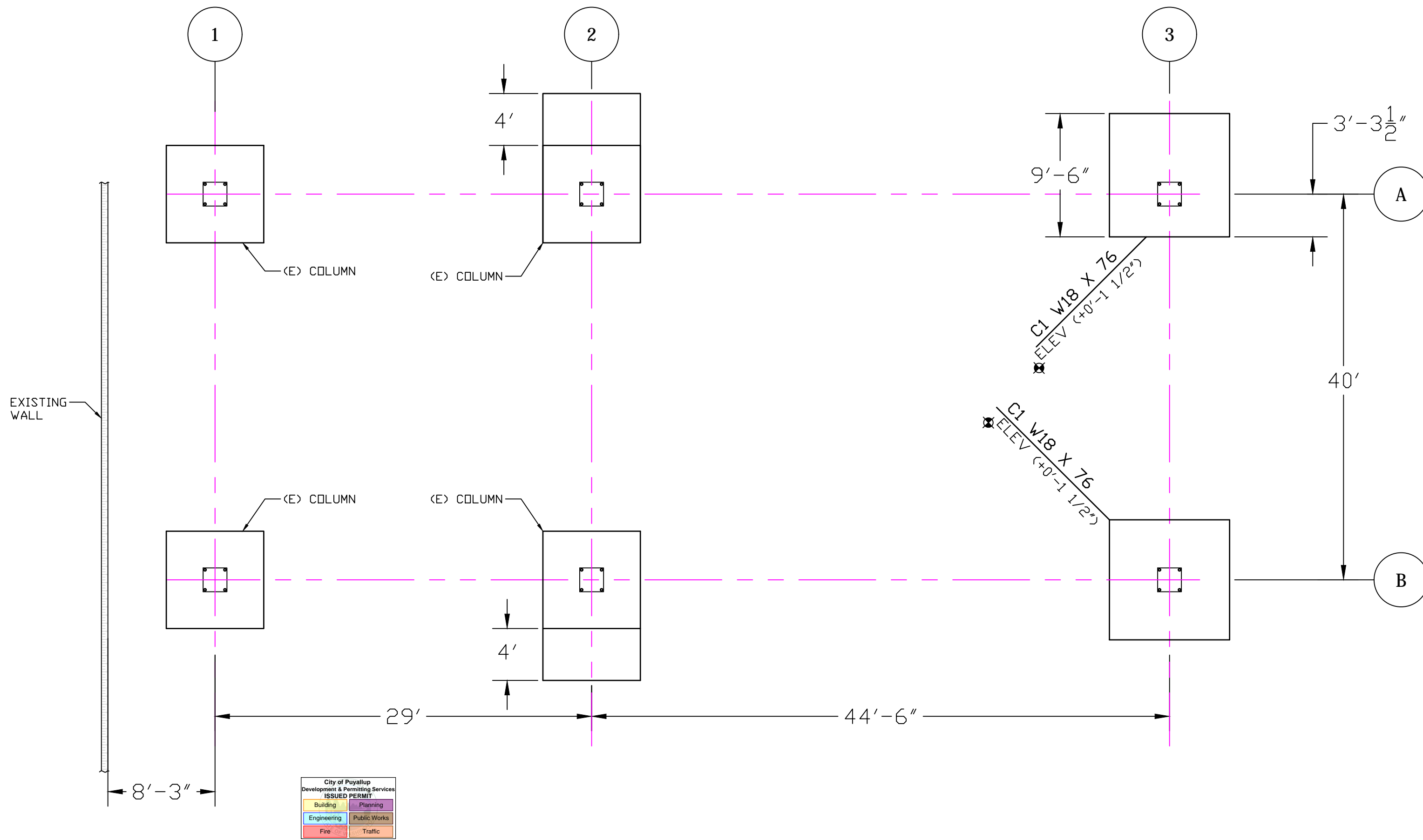

1 FOUNDATION PLAN

SCALE 1:1

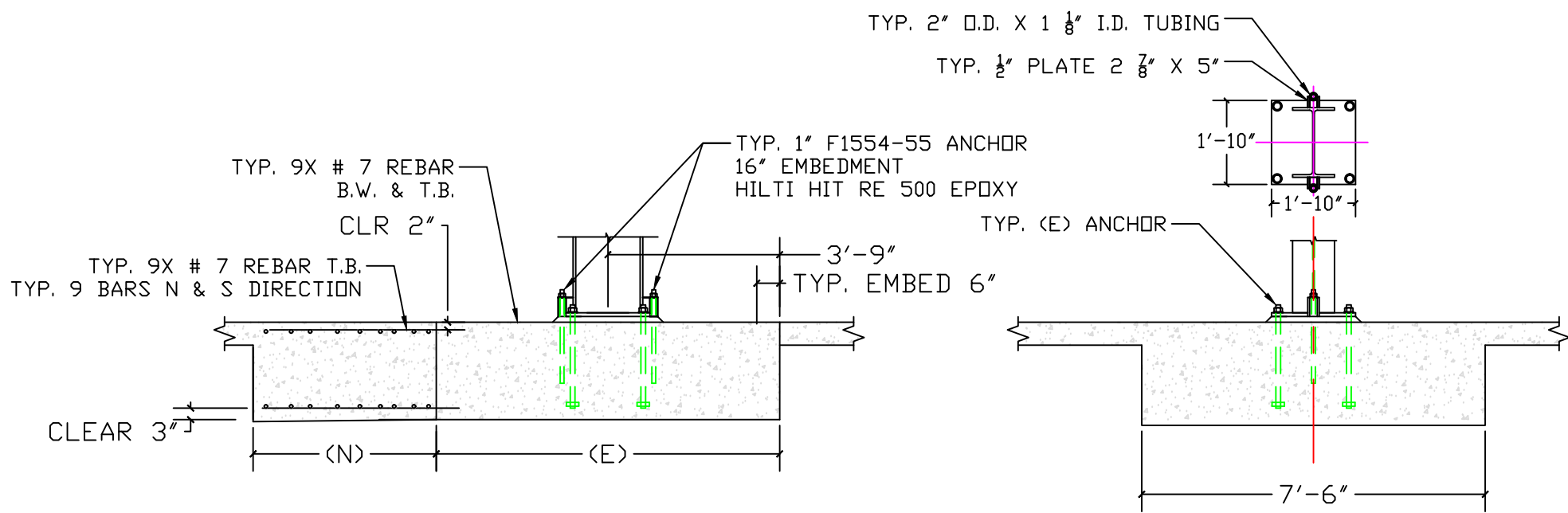

TYP. COL FOUNDATION (GRIDLINE 2)

SCALE 1:1

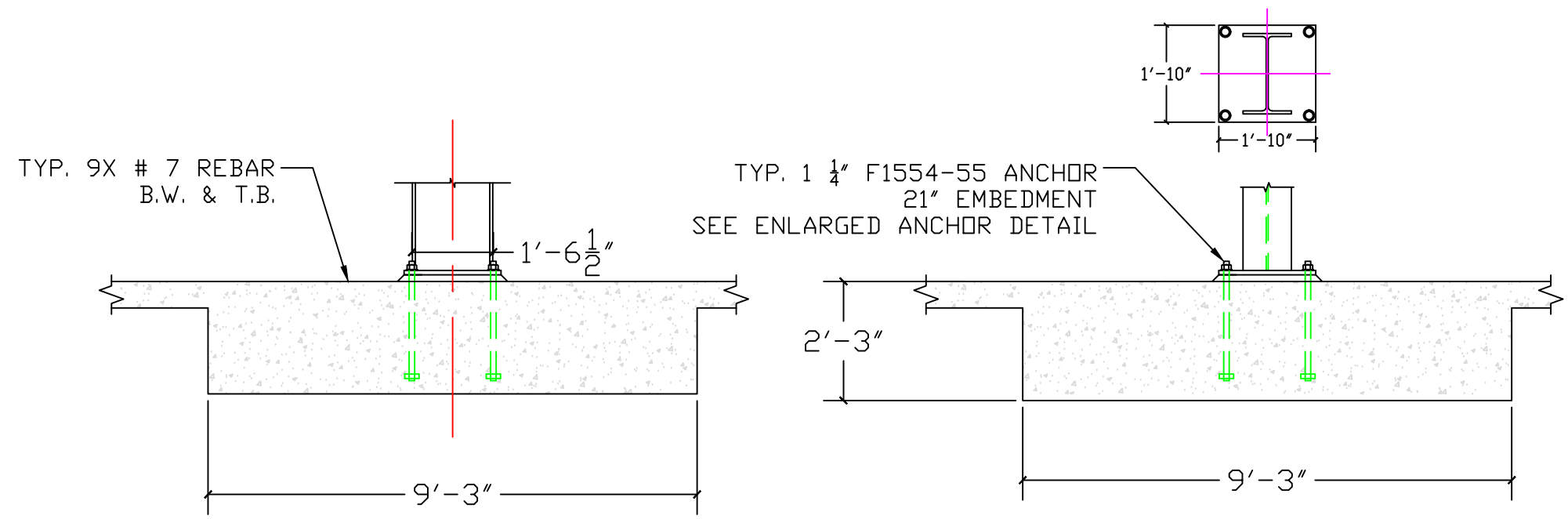

TYP. COL FOUNDATION (GRIDLINE 3)

SCALE 1:1

10 TON BRIDGE CRANE RUNWAY			
DESIGNED: K.L. RAMSEY			
DRAWN:			
CHECKED:			
DATE: 3-26-19			
NO.			DATE

DRAWINGS PREPARED FOR: **KONECRANES - RED DOT** SEATTLE, WA  
 DRAWINGS PREPARED BY: **RAMSEY MACHINE SERVICES, INC.**  
 22845 SAVI RANCH, YORBA LINDA, CA 92887 CSLB 828496 LA FABRICATOR 2040



PROJECT: 8662

SHEET

E1



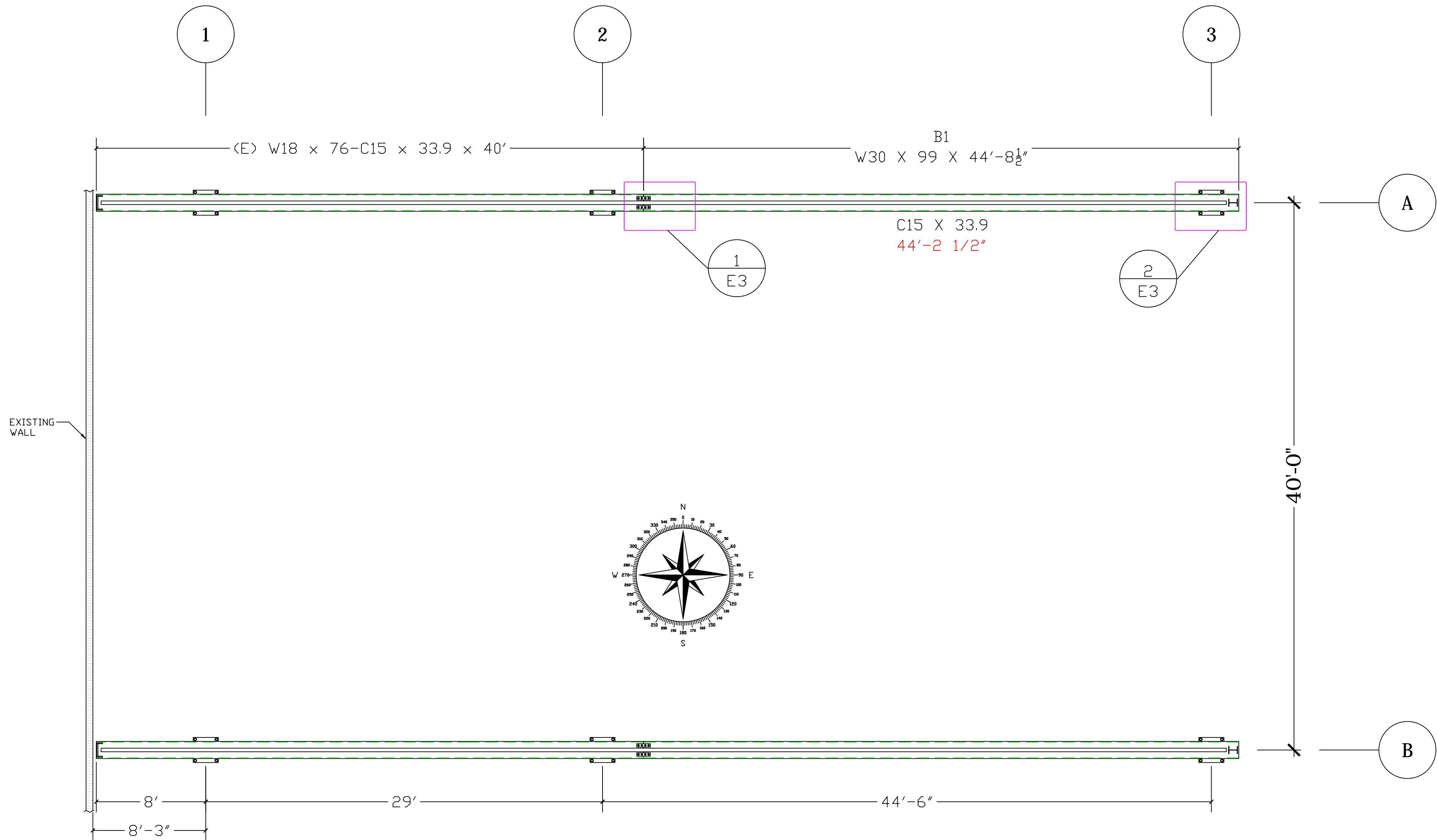

1 ASSEMBLY PLAN

SCALE 1:1

10 TON BRIDGE CRANE RUNWAY	
DESIGNED: K.L. RAMSEY	NO.
DRAWN:	NO.
CHECKED:	NO.
DATE: 3-26-19	DATE

DESIGNED: K.L. RAMSEY	NO.
DRAWN:	NO.
CHECKED:	NO.
DATE: 3-26-19	DATE

DRAWINGS PREPARED FOR: **KONECRANES - RED DOT**  
SEATTLE, WA

DRAWINGS PREPARED BY: **RAMSEY MACHINE SERVICES, INC.**  
22845 SAVI RANCH, YORBA LINDA, CA 92887 CSLB 828496 LA FABRICATOR 2040



PROJECT: 8662

SHEET  
**E2**

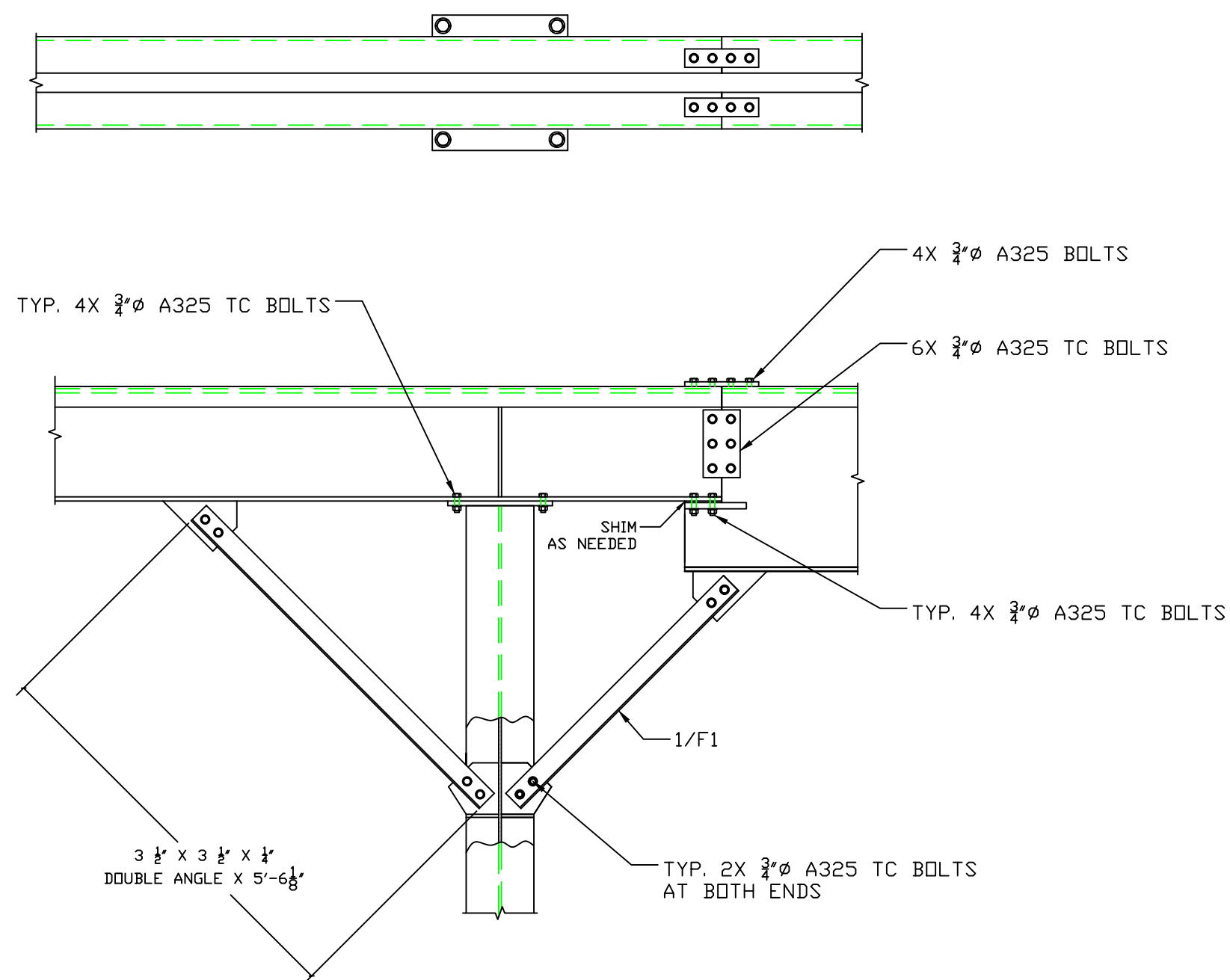
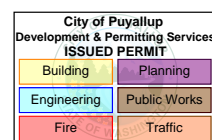

1

SCALE 1:1

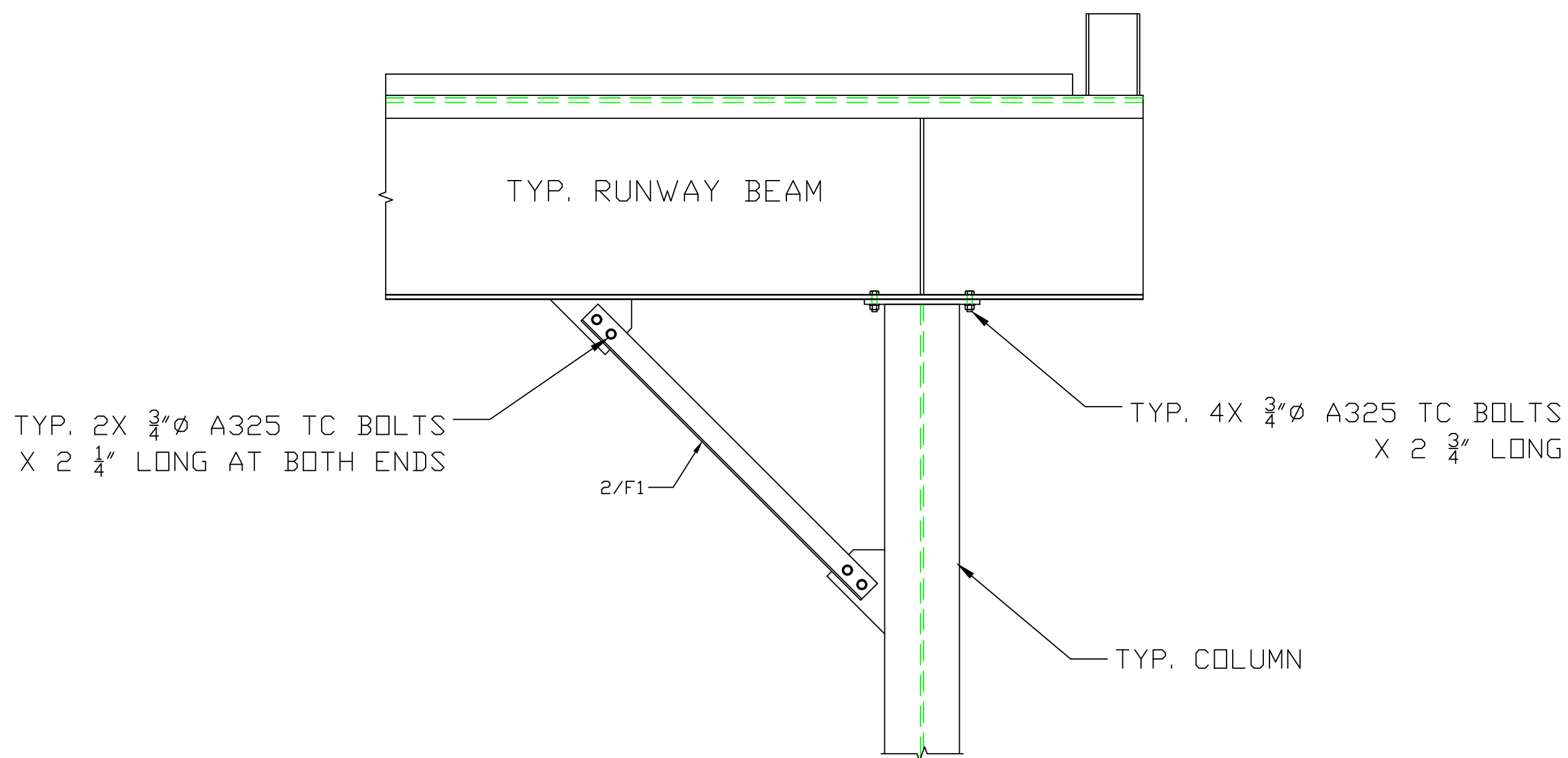

2

SCALE 1:1

10 TON BRIDGE CRANE RUNWAY			
DESIGNED: K.L. RAMSEY	NO.	DATE	
DRAWN:			
CHECKED:			
DATE: 3-26-19			

DESIGNED: K.L. RAMSEY	NO.	DATE
DRAWN:		
CHECKED:		
DATE: 3-26-19		

DRAWINGS PREPARED FOR: **KONECRANES - RED DOT**  
SEATTLE, WA

DRAWINGS PREPARED BY: **RAMSEY MACHINE SERVICES, INC.**  
22845 SAVI RANCH, YORBA LINDA, CA 92887 CSLB 828496 LA FABRICATOR 2040



PROJECT: 8662

SHEET  
**E3**

PRCTI20221709

⚠ This is a beta release of the new ATC Hazards by Location website. Please [contact us](#) with feedback.

ℹ The ATC Hazards by Location website will not be updated to support ASCE 7-22. [Find out why.](#)

# ATC Hazards by Location

## Search Information

**Coordinates:** 47.19119836700967, -122.2611706795929

**Elevation:** 55 ft

**Timestamp:** 2022-10-05T02:44:43.491Z

**Hazard Type:** Wind



### ASCE 7-16

MRI 10-Year ..... 67 mph

MRI 25-Year ..... 73 mph

MRI 50-Year ..... 78 mph

MRI 100-Year ..... 82 mph

Risk Category I ..... 92 mph

Risk Category II ..... 97 mph

Risk Category III ..... 104 mph

Risk Category IV ..... 108 mph

### ASCE 7-10

MRI 10-Year ..... 72 mph

MRI 25-Year ..... 79 mph

MRI 50-Year ..... 85 mph

MRI 100-Year ..... 91 mph

Risk Category I ..... 100 mph

Risk Category II ..... 110 mph

Risk Category III-IV ..... 115 mph

### ASCE 7-05

ASCE 7-05 Wind Speed ..... 85 mph

**SEE SHEET SHEET 2 FOR ENGINEER OF RECORD SEAL FOR ENCLOSED PLANS.**

The results indicated here DO NOT reflect any state or local amendments to the values or any delineation lines made during the building code adoption process. Users should confirm any output obtained from this tool with the local Authority Having Jurisdiction before proceeding with design.

Please note that the ATC Hazards by Location website will not be updated to support ASCE 7-22. [Find out why.](#)

## Disclaimer

Hazard loads are interpolated from data provided in ASCE 7 and rounded up to the nearest whole integer. Per ASCE 7, islands and coastal areas outside the last contour should use the last wind speed contour of the coastal area – in some cases, this website will extrapolate past the last wind speed contour and therefore, provide a wind speed that is slightly higher. NOTE: For queries near wind-borne debris region boundaries, the resulting determination is sensitive to rounding which may affect whether or not it is considered to be within a wind-borne debris region.

Mountainous terrain, gorges, ocean promontories, and special wind regions shall be examined for unusual wind conditions.

While the information presented on this website is believed to be correct, ATC and its sponsors and contributors assume no responsibility or liability for its accuracy. The material presented in the report should not be used or relied upon for any specific application without competent examination and verification of its accuracy, suitability and applicability by engineers or other licensed professionals. ATC does not intend that the use of this information replace the sound judgment of such competent professionals, having experience and knowledge in the field of practice, nor to substitute for the standard of care required of such professionals in interpreting and applying the results of the report provided by this website. Users of the information from this website assume all liability arising from such use. Use of the output of this website does not imply approval by the governing building code authority responsible for building code approval and interpretation for the building site described by latitude/longitude location in the report.

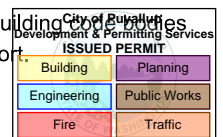

PRCTI20221709

⚠ This is a beta release of the new ATC Hazards by Location website. Please [contact us](#) with feedback.

ℹ The ATC Hazards by Location website will not be updated to support ASCE 7-22. [Find out why.](#)

# ATC Hazards by Location

## Search Information

**Coordinates:** 47.19119836700967, -122.2611706795929  
**Elevation:** 55 ft  
**Timestamp:** 2022-10-05T02:47:09.267Z  
**Hazard Type:** Seismic  
**Reference Document:** ASCE7-16  
**Risk Category:** II  
**Site Class:** D-default

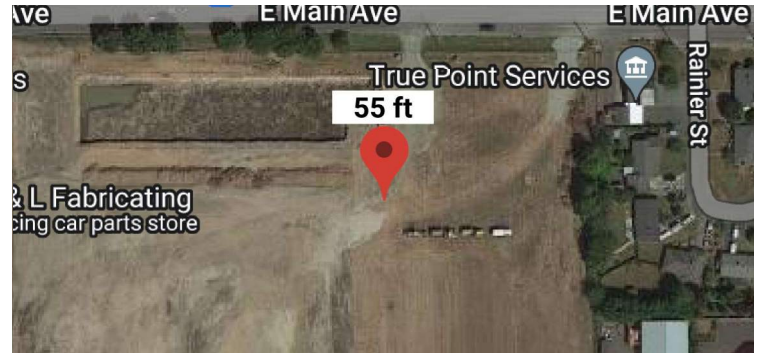

Map data ©2022 Imagery ©2022, Maxar Technologies, U.S. Geological Survey, USDA/FPAC/GEO

SEE SHEET SHEET 2 FOR ENGINEER OF RECORD SEAL FOR ENCLOSED PLANS.

## Basic Parameters

Name	Value	Description
S <sub>S</sub>	1.258	MCE <sub>R</sub> ground motion (period=0.2s)
S <sub>1</sub>	0.433	MCE <sub>R</sub> ground motion (period=1.0s)
S <sub>MS</sub>	1.509	Site-modified spectral acceleration value
S <sub>M1</sub>	* null	Site-modified spectral acceleration value
S <sub>DS</sub>	1.006	Numeric seismic design value at 0.2s SA
S <sub>D1</sub>	* null	Numeric seismic design value at 1.0s SA

\* See Section 11.4.8

## Additional Information

Name	Value	Description
SDC	* null	Seismic design category
F <sub>a</sub>	1.2	Site amplification factor at 0.2s
F <sub>v</sub>	* null	Site amplification factor at 1.0s
CR <sub>S</sub>	0.914	Coefficient of risk (0.2s)
CR <sub>1</sub>	0.898	Coefficient of risk (1.0s)
PGA	0.5	MCE <sub>G</sub> peak ground acceleration
F <sub>PGA</sub>	1.2	Site amplification factor at PGA

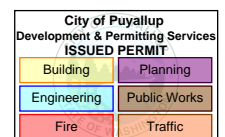

PRCTI20221709

PGA <sub>M</sub>	0.6	Site modified peak ground acceleration
T <sub>L</sub>	6	Long-period transition period (s)
SsRT	1.258	Probabilistic risk-targeted ground motion (0.2s)
SsUH	1.376	Factored uniform-hazard spectral acceleration (2% probability of exceedance in 50 years)
SsD	1.5	Factored deterministic acceleration value (0.2s)
S1RT	0.433	Probabilistic risk-targeted ground motion (1.0s)
S1UH	0.482	Factored uniform-hazard spectral acceleration (2% probability of exceedance in 50 years)
S1D	0.6	Factored deterministic acceleration value (1.0s)
PGAd	0.5	Factored deterministic acceleration value (PGA)

\* See Section 11.4.8

The results indicated here DO NOT reflect any state or local amendments to the values or any delineation lines made during the building code adoption process. Users should confirm any output obtained from this tool with the local Authority Having Jurisdiction before proceeding with design.

Please note that the ATC Hazards by Location website will not be updated to support ASCE 7-22. [Find out why.](#)

### Disclaimer

Hazard loads are provided by the U.S. Geological Survey [Seismic Design Web Services](#).

While the information presented on this website is believed to be correct, ATC and its sponsors and contributors assume no responsibility or liability for its accuracy. The material presented in the report should not be used or relied upon for any specific application without competent examination and verification of its accuracy, suitability and applicability by engineers or other licensed professionals. ATC does not intend that the use of this information replace the sound judgment of such competent professionals, having experience and knowledge in the field of practice, nor to substitute for the standard of care required of such professionals in interpreting and applying the results of the report provided by this website. Users of the information from this website assume all liability arising from such use. Use of the output of this website does not imply approval by the governing building code bodies responsible for building code approval and interpretation for the building site described by latitude/longitude location in the report.

SEE SHEET SHEET 2 FOR ENGINEER OF RECORD SEAL FOR ENCLOSED PLANS.

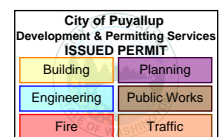

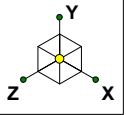

SEE SHEET SHEET 2 FOR ENGINEER OF RECORD SEAL FOR ENCLOSED PLANS.

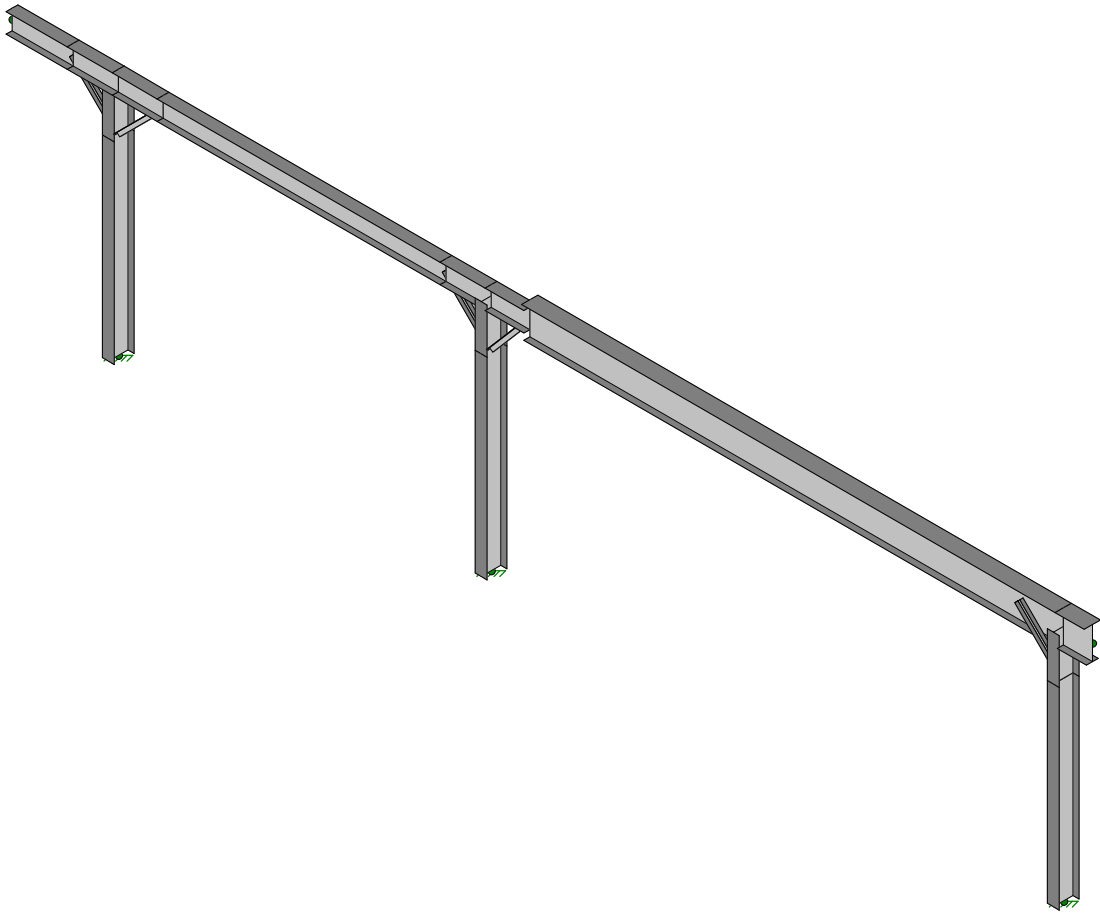

AHBL  
ADM  
2220760.20

Bridge Crane

1  
Oct 26, 2022  
Bridge Crane

City of Puyallup  
Department of Building Services  
ISSUED PERMIT

Building	Planning
Engineering	Public Works
Fire	Traffic

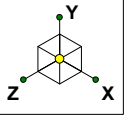

SEE SHEET SHEET 2 FOR ENGINEER OF RECORD SEAL FOR ENCLOSED PLANS.

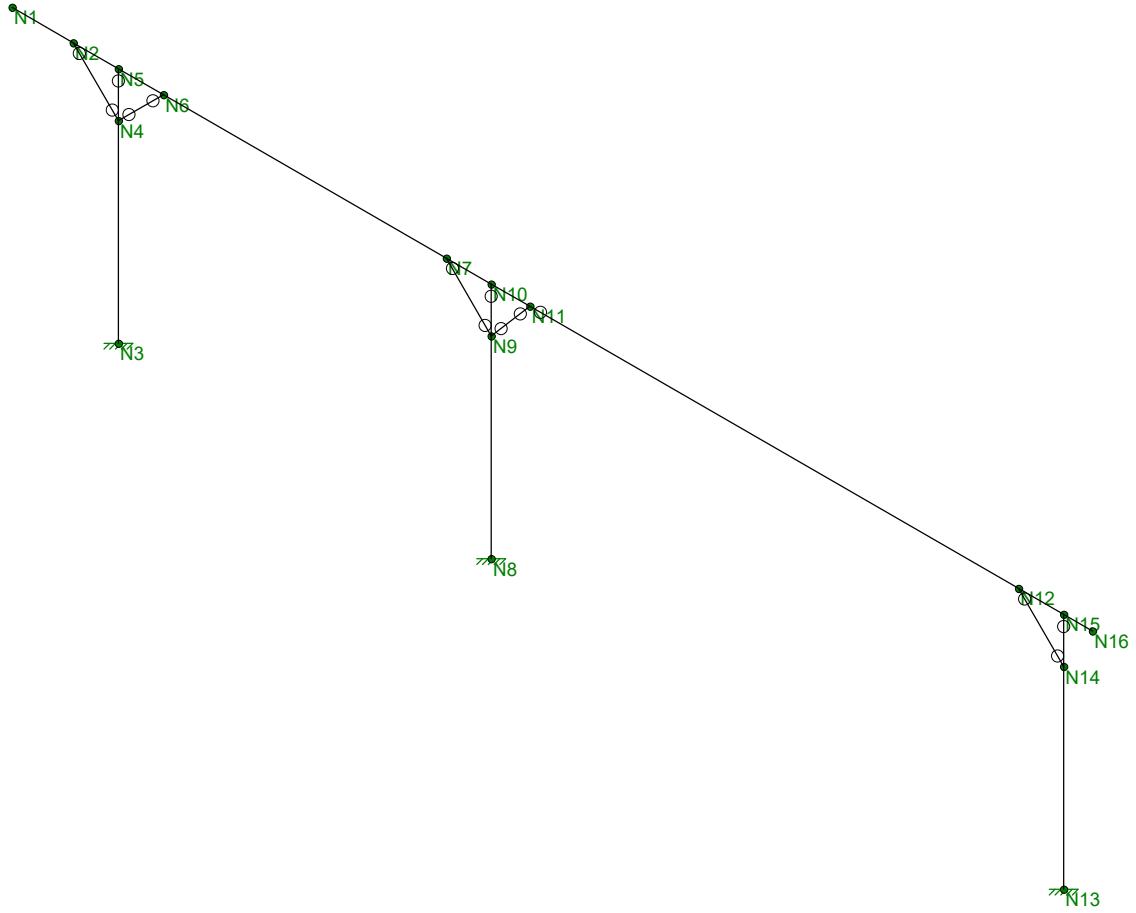

AHBL  
ADM  
2220760.20

Bridge Crane

2  
Oct 26, 2022 at 1:31 PM  
City of Puyallup  
Department of Permitting & Licensing  
ISSUED PERMIT  
Building Planning  
Engineering Public Works  
Fire Traffic

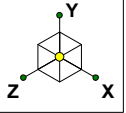

SEE SHEET SHEET 2 FOR ENGINEER OF RECORD SEAL FOR ENCLOSED PLANS.

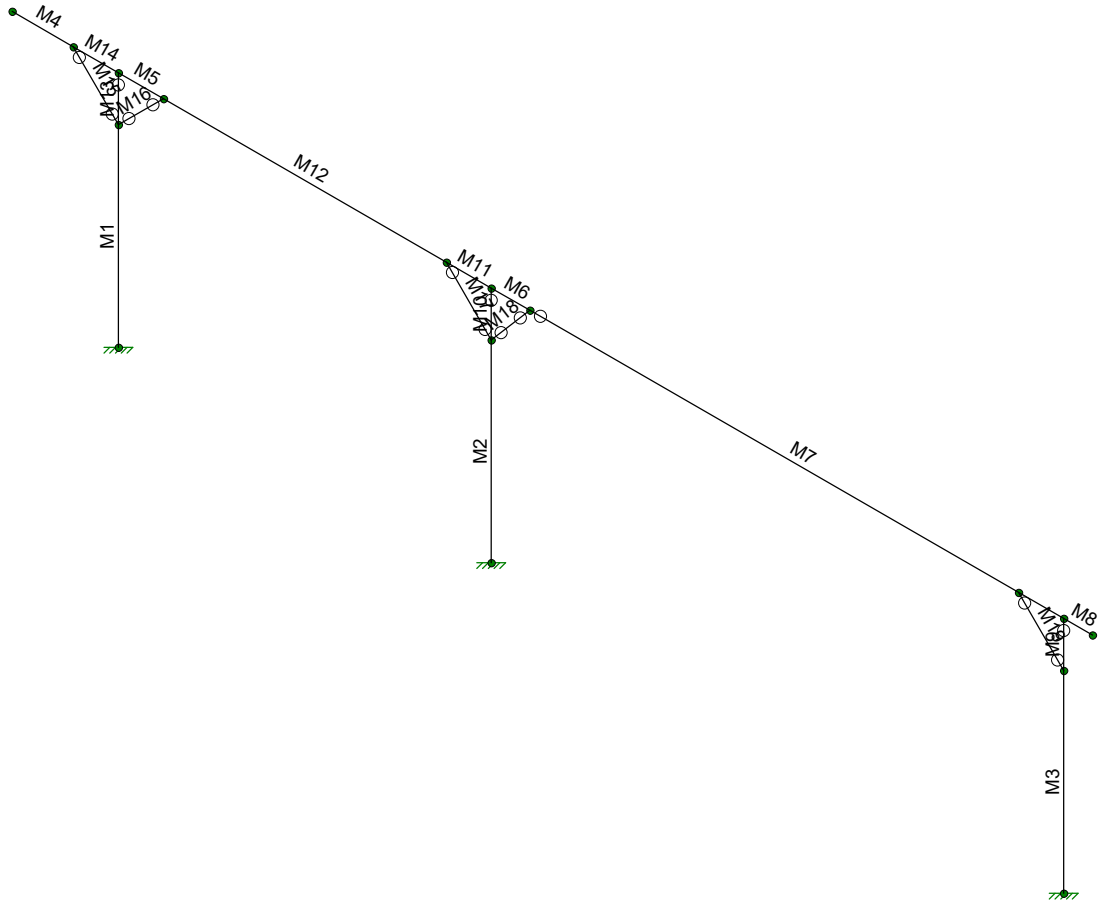

AHBL  
ADM  
2220760.20

Bridge Crane

3  
Oct 26, 2022 at 1:35 PM  
City of Puyallup  
Department of Permitting & Inspections  
ISSUED PERMIT  
Bridge Crane

Building	Planning
Engineering	Public Works
Fire	Traffic





Company : AHBL  
 Designer : ADM  
 Job Number : 2220760.20  
 Model Name : Bridge Crane

Oct 26, 2022  
 4:29 PM  
 Checked By: ADM

SEE SHEET SHEET 2 FOR ENGINEER OF  
 RECORD SEAL FOR ENCLOSED PLANS.

### (Global) Model Settings

Display Sections for Member Calcs	5
Max Internal Sections for Member Calcs	97
Include Shear Deformation?	Yes
Increase Nailing Capacity for Wind?	Yes
Merge Tolerance (in)	0.12
P-Delta Analysis Tolerance	0.50%
Include P-Delta for Walls?	Yes
Automatically Iterate Stiffness for Walls?	Yes
Max Iterations for Wall Stiffness	3
Gravity Acceleration (ft/sec^2)	32.2
Wall Mesh Size (in)	12
Eigensolution Convergence Tol. (1.E-)	4
Dynamic Solver	Accelerated Solver

Hot Rolled Steel Code	AISC 14th (360-10): ASD
Adjust Stiffness?	Yes(Iterative)
Cold Formed Steel Code	AISI S100-12: ASD
Wood Code	AWC NDS-15: ASD
Wood Temperature	< 100F
Concrete Code	ACI 318-14
Masonry Code	ACI 530-05: ASD
Aluminum Code	AA ADM1-10: ASD - Building
Number of Shear Regions	4
Region Spacing Increment (in)	4
Concrete Stress Block	Rectangular
Use Cracked Sections?	Yes
Bad Framing Warnings?	No
Unused Force Warnings?	Yes
Min 1 Bar Diam. Spacing?	No
Concrete Rebar Set	REBAR SET ASTMA615
Min % Steel for Column	1
Max % Steel for Column	8

### General Material Properties

	Label	E [ksi]	G [ksi]	Nu	Therm (/1E5 F)	Density[k/ft^3]
1	gen_Conc3NW	3155	1372	0.15	0.6	0.145
2	gen_Conc4NW	3644	1584	0.15	0.6	0.145
3	gen_Conc3LW	2085	906	0.15	0.6	0.11
4	gen_Conc4LW	2408	1047	0.15	0.6	0.11
5	gen Alum	10600	4077	0.3	1.29	0.173
6	gen_Steel	29000	11154	0.3	0.65	0.49
7	RIGID	1e+6		0.3	0	0

### Hot Rolled Steel Properties

	Label	E [ksi]	G [ksi]	Nu	Therm (/1E5 F)	Density[k/ft^3]	Yield[ksi]
1	A36 Gr.36	29000	11154	0.3	0.65	0.49	36
2	A572 Gr.50	29000	11154	0.3	0.65	0.49	50
3	A992	29000	11154	0.3	0.65	0.49	50
4	A500 Gr.42	29000	11154	0.3	0.65	0.49	42
5	A500 Gr.46	29000	11154	0.3	0.65	0.49	46

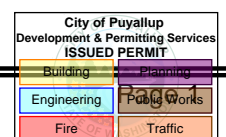



SEE SHEET SHEET 2 FOR ENGINEER OF RECORD SEAL FOR ENCLOSED PLANS.

**General Section Sets**

	Label	Shape	Type	Material	A [in2]	I (90,270) [in4]	I (0,180) [in4]
1	GEN1A	RE4X4	Beam	gen Conc3NW	16	21.333	21.333
2	RIGID		None	RIGID	1e+6	1e+6	1e+6

**Hot Rolled Steel Section Sets**

	Label	Shape	Type	Design List	Material	Design Rules	A [in2]	I (90,270) [in4]	I (0,180) [in4]
1	Col	W18X76	Column	Wide Flange	A992	Typical	22.3	152	1330
2	W18x Beam	W18X76	Beam	Wide Flange	A992	Typical	22.3	152	1330
3	W30x Beam	W30x99withC15	Beam	Wide Flange	A992	Typical	36.2	346.179	5269.516
4	L braces	LL3.5x3.5x4x3	VBrace	Double Angle (3/8 Gap)	A36 Gr.36	Typical	3.4	8.38	4

**Member Primary Data**

	Label	I Joint	J Joint	Rotate(d...)	Section/Shape	Type	Design List	Material	Design Rules
1	M1	N3	N4	90	Col	Column	Wide Flange	A992	Typical
2	M2	N8	N9	90	Col	Column	Wide Flange	A992	Typical
3	M3	N13	N14	90	Col	Column	Wide Flange	A992	Typical
4	M4	N1	N2		W18x Beam	Beam	Wide Flange	A992	Typical
5	M5	N5	N6		W18x Beam	Beam	Wide Flange	A992	Typical
6	M6	N10	N11		W18x Beam	Beam	Wide Flange	A992	Typical
7	M7	N11	N15		W30x Beam	Beam	Wide Flange	A992	Typical
8	M8	N15	N16		W30x Beam	Beam	Wide Flange	A992	Typical
9	M9	N14	N15	90	Col	Column	Wide Flange	A992	Typical
10	M10	N9	N10	90	Col	Column	Wide Flange	A992	Typical
11	M11	N7	N10		W18x Beam	Beam	Wide Flange	A992	Typical
12	M12	N6	N7		W18x Beam	Beam	Wide Flange	A992	Typical
13	M13	N4	N5	90	Col	Column	Wide Flange	A992	Typical
14	M14	N2	N5		W18x Beam	Beam	Wide Flange	A992	Typical
15	M15	N2	N4		L braces	VBrace	Double Angl...	A36 Gr.36	Typical
16	M16	N4	N6		L braces	VBrace	Double Angl...	A36 Gr.36	Typical
17	M17	N7	N9		L braces	VBrace	Double Angl...	A36 Gr.36	Typical
18	M18	N9	N11		L braces	VBrace	Double Angl...	A36 Gr.36	Typical
19	M19	N12	N14		L braces	VBrace	Double Angl...	A36 Gr.36	Typical

**Member Advanced Data**

	Label	I Release	J Release	I Offset[in]	J Offset[in]	T/C Only	Physical	Defl Rati...	TOM	Inactive
1	M1							** NA **		
2	M2							** NA **		
3	M3							** NA **		
4	M4									
5	M5									
6	M6									
7	M7	PIN					Yes	Default		
8	M8						Yes			
9	M9		PIN					** NA **		
10	M10		PIN					** NA **		
11	M11									
12	M12									
13	M13		PIN					** NA **		
14	M14									
15	M15	PIN	PIN					** NA **		
16	M16	PIN	PIN					** NA **		
17	M17	PIN	PIN					** NA **		

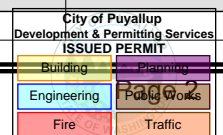



**Member Advanced Data (Continued)**

	Label	I Release	J Release	I Offset[in]	J Offset[in]	T/C Only	Physical	Defl Rati...	TOM	Inactive
18	M18	PIN	PIN					** NA **		
19	M19	PIN	PIN					** NA **		

**Joint Coordinates and Temperatures**

	Label	X [ft]	Y [ft]	Temp [F]
1	N1	0	18.5	0
2	N2	4.75	18.5	0
3	N3	8.25	0	0
4	N4	8.25	15	0
5	N5	8.25	18.5	0
6	N6	11.75	18.5	0
7	N7	33.75	18.5	0
8	N8	37.25	0	0
9	N9	37.25	15	0
10	N10	37.25	18.5	0
11	N11	40.25	18.5	0
12	N12	78.25	18.5	0
13	N13	81.75	0	0
14	N14	81.75	15	0
15	N15	81.75	18.5	0
16	N16	84	18.5	0

**Joint Boundary Conditions**

	Joint Label	X [k/in]	Y [k/in]	Rotation[k-ft/rad]
1	N3	Reaction	Reaction	Reaction
2	N8	Reaction	Reaction	Reaction
3	N13	Reaction	Reaction	Reaction

**Hot Rolled Steel Design Parameters**

	Label	Shape	Lengt...	Lb-out[ft]	Lb-in[ft]	Lcomp to...	Lcomp b...	L-torque...	K-out	K-in	Cb	Channel Conne...	a[ft]	Func...
1	M1	Col	15									N/A	N/A	Lateral
2	M2	Col	15									N/A	N/A	Lateral
3	M3	Col	15									N/A	N/A	Lateral
4	M4	W18x Be...	4.75			Lb out						N/A	N/A	Lateral
5	M5	W18x Be...	3.5			Lb out						N/A	N/A	Lateral
6	M6	W18x Be...	3			Lb out						N/A	N/A	Lateral
7	M7	W30x Be...	41.5			Lb out						N/A	N/A	Lateral
8	M8	W30x Be...	2.25			Lb out						N/A	N/A	Lateral
9	M9	Col	3.5									N/A	N/A	Lateral
10	M10	Col	3.5									N/A	N/A	Lateral
11	M11	W18x Be...	3.5			Lb out						N/A	N/A	Lateral
12	M12	W18x Be...	22			Lb out						N/A	N/A	Lateral
13	M13	Col	3.5									N/A	N/A	Lateral
14	M14	W18x Be...	3.5			Lb out						N/A	N/A	Lateral
15	M15	L braces	4.95									N/A	N/A	Lateral
16	M16	L braces	4.95									N/A	N/A	Lateral
17	M17	L braces	4.95									N/A	N/A	Lateral
18	M18	L braces	4.61									N/A	N/A	Lateral
19	M19	L braces	4.95									N/A	N/A	Lateral

SEE SHEET SHEET 2 FOR ENGINEER OF RECORD SEAL FOR ENCLOSED PLANS

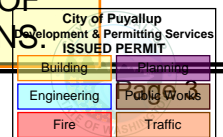



SEE SHEET SHEET 2 FOR ENGINEER OF RECORD SEAL FOR ENCLOSED PLANS.

**Design Size and Code Check Parameters**

	Label	Max Depth[in]	Min Depth[in]	Max Width[in]	Min Width[in]	Max Bending Chk	Max Shear Chk
1	Typical					1	1

**Plate Primary Data**

Label	A Joint	B Joint	C Joint	D Joint	Material	Thickness[in]
No Data to Print ...						

**Joint Loads and Enforced Displacements (BLC 3 : Seismic)**

	Joint Label	L,D,M	Direction	Magnitude[(k,k-ft), (in.rad), (k*s^2/ft, k...	Inactive
1	N5	L	X	1.6	
2	N10	L	X	1.6	
3	N15	L	X	1.6	

**Member Point Loads**

Member Label	Direction	Magnitude[k,k-ft]	Location[ft,%]	Inactive
No Data to Print ...				

**Member Distributed Loads**

Member Label	Direction	Start Magnitude[k/ft,F,k...	End Magnitude[k/ft,F,k...	Start Location[ft,%]	End Location...	Inactive
No Data to Print ...						

**Moving Loads**

Tag	Pattern	Increment[ft]	Both ...	1st Joint	2nd Jo...	3rd Joint	4th Joint	5th Joint	6th Joint	7th Joint	8th Joint	9th Joint	10th J...
1	M1	10TBRIDGE	1	Yes	N1	N5	N10	N11	N15	N16			

**Moving Load Patterns**

Pattern Label	Load (k)	Direction	Distance (ft)
10TBRIDGE	-24.8	Y	0

**Basic Load Cases**

BLC Description	Category	X Gravity	Y Gravity	Joint	Point	Distributed
1 Dead	DL		-1			
2 Live	LL					
3 Seismic	EL	1		3		

**Load Combinations**

Description	S...	PD...	SR...	B...	Fa...	B...	Fa...	B...	Fa...	B...	Fa...	B...	Fa...	B...	Fa...	B...	Fa...	B...	Fa...
1 IBC 16-8	Yes	C		DL	1														
2 IBC 16-9	Yes	C		DL	1	LL	1	L...	1										
3 IBC 16-9 (a)	Yes	C		DL	1	M1	1.1												
4 Seismic	Yes	C		DL	1	EL	1												
5 Seismic	Yes	C		DL	1	EL	-1												

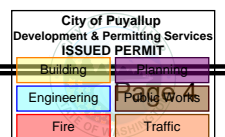



SEE SHEET SHEET 2 FOR ENGINEER OF RECORD SEAL FOR ENCLOSED PLANS.

**Load Combination Design**

	Description	ASIF	CD	Service	Hot Roll...	Cold Formed	Wood	Concrete	Masonry	Aluminum	Stainless
1	IBC 16-8		0.9	Yes	Yes	Yes	Yes	Yes	Yes	Yes	Yes
2	IBC 16-9			Yes	Yes	Yes	Yes	Yes	Yes	Yes	Yes
3	IBC 16-9 (a)		1.25	Yes	Yes	Yes	Yes	Yes	Yes	Yes	Yes
4	Seismic		1.25	Yes	Yes	Yes	Yes	Yes	Yes	Yes	Yes
5	Seismic		1.25	Yes	Yes	Yes	Yes	Yes	Yes	Yes	Yes

**Node Displacements**

	LC	Node Label	X [in]	Y [in]	Rotation [rad]
1	1	N1	-0.014	0.002	-2.618e-5
2	1	N2	-0.014	0.001	-3.25e-5
3	1	N3	0	0	0
4	1	N4	-0.016	-0.001	-3.462e-6
5	1	N5	-0.014	-0.001	-5.272e-5
6	1	N6	-0.014	-0.004	-7.264e-5
7	1	N7	-0.014	-0.003	4.051e-5
8	1	N8	0	0	0
9	1	N9	-0.014	-0.002	2.004e-5
10	1	N10	-0.014	-0.002	-1.631e-5
11	1	N11	-0.014	-0.004	-4.361e-5
12	1	N12	-0.014	-0.019	3.867e-4
13	1	N13	0	0	0
14	1	N14	0.002	-0.001	2.841e-4
15	1	N15	-0.014	-0.002	3.981e-4
16	1	N16	-0.014	0.009	3.978e-4
17	2	N1	-0.014	0.002	-2.618e-5
18	2	N2	-0.014	0.001	-3.25e-5
19	2	N3	0	0	0
20	2	N4	-0.016	-0.001	-3.462e-6
21	2	N5	-0.014	-0.001	-5.272e-5
22	2	N6	-0.014	-0.004	-7.264e-5
23	2	N7	-0.014	-0.003	4.051e-5
24	2	N8	0	0	0
25	2	N9	-0.014	-0.002	2.004e-5
26	2	N10	-0.014	-0.002	-1.631e-5
27	2	N11	-0.014	-0.004	-4.361e-5
28	2	N12	-0.014	-0.019	3.867e-4
29	2	N13	0	0	0
30	2	N14	0.002	-0.001	2.841e-4
31	2	N15	-0.014	-0.002	3.981e-4
32	2	N16	-0.014	0.009	3.978e-4
33	4	N1	1.041	0.108	-1.081e-3
34	4	N2	1.041	0.046	-1.087e-3
35	4	N3	0	0	0
36	4	N4	0.988	0	-2.904e-3
37	4	N5	1.041	0	-9.877e-4
38	4	N6	1.041	-0.038	-5.751e-4
39	4	N7	1.041	0.026	-3.374e-4
40	4	N8	0	0	0
41	4	N9	0.996	-0.002	-2.782e-3
42	4	N10	1.042	-0.002	-7.919e-4
43	4	N11	1.042	-0.036	-9.088e-4
44	4	N12	1.042	0.011	-1.65e-4
45	4	N13	0	0	0
46	4	N14	1.006	-0.002	0

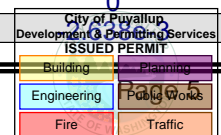



**Node Displacements (Continued)**

	LC	Node Label	X [in]	Y [in]	Rotation [rad]
47	4	N15	1.042	-0.001	-2.477e-4
48	4	N16	1.043	-0.008	-2.48e-4
49	5	N1	-1.068	-0.103	1.022e-3
50	5	N2	-1.068	-0.045	1.015e-3
51	5	N3	0	0	0
52	5	N4	-1.019	-0.002	2.891e-3
53	5	N5	-1.068	-0.002	8.757e-4
54	5	N6	-1.067	0.03	4.245e-4
55	5	N7	-1.068	-0.031	4.231e-4
56	5	N8	0	0	0
57	5	N9	-1.024	-0.001	2.826e-3
58	5	N10	-1.069	-0.001	7.648e-4
59	5	N11	-1.069	0.029	8.274e-4
60	5	N12	-1.069	-0.049	9.396e-4
61	5	N13	0	0	0
62	5	N14	-1.001	-0.001	3.207e-3
63	5	N15	-1.069	-0.002	1.045e-3
64	5	N16	-1.069	0.026	1.045e-3

**Node Reactions (By Combination)**

	LC	Node Label	X [k]	Y [k]	MZ [k-ft]
1	1	N3	0.114	3.141	-0.851
2	1	N8	0.088	5.432	-0.694
3	1	N13	-0.201	4.364	1.048
4	1	Totals:	0	12.937	
5	1	COG (ft):	X: 46.9	Y: 15.451	
6	2	N3	0.114	3.141	-0.851
7	2	N8	0.088	5.432	-0.694
8	2	N13	-0.201	4.364	1.048
9	2	Totals:	0	12.937	
10	2	COG (ft):	X: 46.9	Y: 15.451	
11	4	N3	-5.801	-0.231	45.401
12	4	N8	-5.878	7.603	46.248
13	4	N13	-6.059	5.565	47.236
14	4	Totals:	-17.737	12.937	
15	4	COG (ft):	X: 46.9	Y: 15.451	
16	5	N3	5.979	6.511	-47.121
17	5	N8	6.085	3.267	-47.591
18	5	N13	5.673	3.159	-45.111
19	5	Totals:	17.737	12.937	
20	5	COG (ft):	X: 46.9	Y: 15.451	

**Member Section Forces**

	LC	Member Label	Sec	Axial[k]	Shear[k]	Moment[k-ft]
1	1	M1	1	3.141	-0.114	-0.851
2			2	2.857	-0.114	-0.423
3			3	2.572	-0.114	0.006
4			4	2.287	-0.114	0.434
5			5	2.003	-0.114	0.863
6	1	M2	1	5.432	-0.088	-0.694
7			2	5.148	-0.088	-0.363
8			3	4.863	-0.088	-0.033
9			4	4.579	-0.088	
10			5	4.294	-0.088	

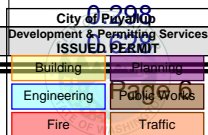

SEE SHEET SHEET 2 FOR ENGINEER OF RECORD SEAL FOR ENCLOSED PLANS.



**Member Section Forces (Continued)**

	LC	Member Label	Sec	Axial[k]	Shear[k]	Moment[k-ft]
11	1	M3	1	4.364	0.202	1.048
12			2	4.079	0.202	0.292
13			3	3.795	0.202	-0.464
14			4	3.51	0.202	-1.22
15			5	3.226	0.202	-1.975
16	1	M4	1	0	0	0
17			2	0	-0.09	0.054
18			3	0	-0.18	0.214
19			4	0	-0.27	0.482
20			5	0	-0.36	0.856
21	1	M5	1	-0.506	0.406	1.775
22			2	-0.506	0.339	1.449
23			3	-0.506	0.273	1.181
24			4	-0.506	0.207	0.971
25			5	-0.506	0.14	0.819
26	1	M6	1	-0.904	1.452	4.014
27			2	-0.904	1.395	2.946
28			3	-0.904	1.338	1.921
29			4	-0.904	1.281	0.939
30			5	-0.904	1.224	0
31	1	M7	1	0.201	2.487	0
32			2	0.201	1.209	-19.166
33			3	0.201	-0.069	-25.074
34			4	0.201	-1.347	-17.724
35			5	-0.563	-1.891	0.312
36	1	M8	1	0	0.277	0.312
37			2	0	0.208	0.175
38			3	0	0.139	0.078
39			4	0	0.069	0.019
40			5	0	0	0
41	1	M9	1	2.433	-0.564	-1.975
42			2	2.367	-0.564	-1.482
43			3	2.301	-0.564	-0.988
44			4	2.234	-0.564	-0.494
45			5	2.168	-0.564	0
46	1	M10	1	2.112	0.18	0.628
47			2	2.045	0.18	0.471
48			3	1.979	0.18	0.314
49			4	1.913	0.18	0.157
50			5	1.846	0.18	0
51	1	M11	1	-0.724	-0.129	3.098
52			2	-0.724	-0.195	3.24
53			3	-0.724	-0.262	3.44
54			4	-0.724	-0.328	3.698
55			5	-0.724	-0.394	4.014
56	1	M12	1	0.114	0.731	0.819
57			2	0.114	0.314	-2.054
58			3	0.114	-0.104	-2.632
59			4	0.114	-0.521	-0.915
60			5	0.114	-0.938	3.098
61	1	M13	1	1.067	0.246	0.863
62			2	1	0.246	0.647
63			3	0.934	0.246	0.431
64			4	0.867	0.246	0.216
65			5	0.801	0.246	0
66	1	M14	1	-0.259	-0.13	
67			2	-0.259	-0.196	





**Member Section Forces (Continued)**

LC	Member Label	Sec	Axial[k]	Shear[k]	Moment[k-ft]
68		3	-0.259	-0.262	1.199
69		4	-0.259	-0.329	1.458
70		5	-0.259	-0.395	1.775
71	1	1	0.347	0.02	0
72		2	0.357	0.01	-0.019
73		3	0.367	0	-0.025
74		4	0.377	-0.01	-0.019
75		5	0.387	-0.02	0
76	1	1	0.897	0.02	0
77		2	0.886	0.01	-0.019
78		3	0.876	0	-0.025
79		4	0.866	-0.01	-0.019
80		5	0.856	-0.02	0
81	1	1	1.165	0.02	0
82		2	1.175	0.01	-0.019
83		3	1.185	0	-0.025
84		4	1.195	-0.01	-0.019
85		5	1.205	-0.02	0
86	1	1	1.718	0.017	0
87		2	1.708	0.009	-0.015
88		3	1.698	0	-0.02
89		4	1.688	-0.009	-0.015
90		5	1.678	-0.017	0
91	1	1	1.06	0.02	0
92		2	1.07	0.01	-0.019
93		3	1.08	0	-0.025
94		4	1.091	-0.01	-0.019
95		5	1.101	-0.02	0
96	2	1	3.141	-0.114	-0.851
97		2	2.857	-0.114	-0.423
98		3	2.572	-0.114	0.006
99		4	2.287	-0.114	0.434
100		5	2.003	-0.114	0.863
101	2	1	5.432	-0.088	-0.694
102		2	5.148	-0.088	-0.363
103		3	4.863	-0.088	-0.033
104		4	4.579	-0.088	0.298
105		5	4.294	-0.088	0.628
106	2	1	4.364	0.202	1.048
107		2	4.079	0.202	0.292
108		3	3.795	0.202	-0.464
109		4	3.51	0.202	-1.22
110		5	3.226	0.202	-1.975
111	2	1	0	0	0
112		2	0	-0.09	0.054
113		3	0	-0.18	0.214
114		4	0	-0.27	0.482
115		5	0	-0.36	0.856
116	2	1	-0.506	0.406	1.775
117		2	-0.506	0.339	1.449
118		3	-0.506	0.273	1.181
119		4	-0.506	0.207	0.971
120		5	-0.506	0.14	0.819
121	2	1	-0.904	1.452	4.014
122		2	-0.904	1.395	2.946
123		3	-0.904	1.338	
124		4	-0.904	1.281	

City of Portland  
 Development & Permitting Services  
 ISSUED PERMIT

Building Planning  
 Engineering Public Works  
 Fire Traffic

SEE SHEET SHEET 2 FOR ENGINEER OF RECORD SEAL FOR ENCLOSED PLANS.





**Member Section Forces (Continued)**

LC	Member Label	Sec	Axial[k]	Shear[k]	Moment[k-ft]
125		5	-0.904	1.224	0
126	2	1	0.201	2.487	0
127		2	0.201	1.209	-19.166
128		3	0.201	-0.069	-25.074
129		4	0.201	-1.347	-17.724
130		5	-0.563	-1.891	0.312
131	2	1	0	0.277	0.312
132		2	0	0.208	0.175
133		3	0	0.139	0.078
134		4	0	0.069	0.019
135		5	0	0	0
136	2	1	2.433	-0.564	-1.975
137		2	2.367	-0.564	-1.482
138		3	2.301	-0.564	-0.988
139		4	2.234	-0.564	-0.494
140		5	2.168	-0.564	0
141	2	1	2.112	0.18	0.628
142		2	2.045	0.18	0.471
143		3	1.979	0.18	0.314
144		4	1.913	0.18	0.157
145		5	1.846	0.18	0
146	2	1	-0.724	-0.129	3.098
147		2	-0.724	-0.195	3.24
148		3	-0.724	-0.262	3.44
149		4	-0.724	-0.328	3.698
150		5	-0.724	-0.394	4.014
151	2	1	0.114	0.731	0.819
152		2	0.114	0.314	-2.054
153		3	0.114	-0.104	-2.632
154		4	0.114	-0.521	-0.915
155		5	0.114	-0.938	3.098
156	2	1	1.067	0.246	0.863
157		2	1	0.246	0.647
158		3	0.934	0.246	0.431
159		4	0.867	0.246	0.216
160		5	0.801	0.246	0
161	2	1	-0.259	-0.13	0.856
162		2	-0.259	-0.196	0.999
163		3	-0.259	-0.262	1.199
164		4	-0.259	-0.329	1.458
165		5	-0.259	-0.395	1.775
166	2	1	0.347	0.02	0
167		2	0.357	0.01	-0.019
168		3	0.367	0	-0.025
169		4	0.377	-0.01	-0.019
170		5	0.387	-0.02	0
171	2	1	0.897	0.02	0
172		2	0.886	0.01	-0.019
173		3	0.876	0	-0.025
174		4	0.866	-0.01	-0.019
175		5	0.856	-0.02	0
176	2	1	1.165	0.02	0
177		2	1.175	0.01	-0.019
178		3	1.185	0	-0.025
179		4	1.195	-0.01	-0.019
180		5	1.205	-0.02	0
181	2	1	1.718	0.017	0

City of Pullman  
 Development & Permitting Services  
 ISSUED PERMIT

Building Planning  
 Engineering Public Works  
 Fire Traffic

SEE SHEET SHEET 2 FOR ENGINEER OF RECORD SEAL FOR ENCLOSED PLANS.



**Member Section Forces (Continued)**

LC	Member Label	Sec	Axial[k]	Shear[k]	Moment[k-ft]	
182		2	1.708	0.009	-0.015	
183		3	1.698	0	-0.02	
184		4	1.688	-0.009	-0.015	
185		5	1.678	-0.017	0	
186	2	M19	1	1.06	0.02	0
187		2	1.07	0.01	-0.019	
188		3	1.08	0	-0.025	
189		4	1.091	-0.01	-0.019	
190		5	1.101	-0.02	0	
191	4	M1	1	-0.231	5.801	45.401
192		2	-0.516	5.516	24.182	
193		3	-0.8	5.232	4.029	
194		4	-1.085	4.947	-15.056	
195		5	-1.369	4.663	-33.074	
196	4	M2	1	7.603	5.94	46.248
197		2	7.319	5.656	24.506	
198		3	7.034	5.371	3.831	
199		4	6.75	5.086	-15.776	
200		5	6.465	4.802	-34.317	
201	4	M3	1	5.565	6.103	47.236
202		2	5.281	5.819	24.882	
203		3	4.996	5.534	3.595	
204		4	4.711	5.25	-16.624	
205		5	4.427	4.965	-35.777	
206	4	M4	1	0	0	0
207		2	0.09	-0.09	0.053	
208		3	0.18	-0.18	0.213	
209		4	0.27	-0.27	0.48	
210		5	0.36	-0.36	0.855	
211	4	M5	1	7.414	7.163	-12.883
212		2	7.481	7.097	-19.122	
213		3	7.547	7.03	-25.302	
214		4	7.613	6.964	-31.425	
215		5	7.68	6.898	-37.489	
216	4	M6	1	0.937	5.721	16.822
217		2	0.994	5.664	12.553	
218		3	1.051	5.607	8.326	
219		4	1.108	5.55	4.142	
220		5	1.165	5.494	0	
221	4	M7	1	-2.392	1.285	0
222		2	-1.114	0.007	-6.702	
223		3	0.164	-1.271	-0.145	
224		4	1.442	-2.549	19.671	
225		5	-12.232	11.153	0.312	
226	4	M8	1	-0.277	0.277	0.312
227		2	-0.208	0.208	0.175	
228		3	-0.139	0.139	0.078	
229		4	-0.069	0.069	0.019	
230		5	0	0	0	
231	4	M9	1	-10.611	-10.089	-35.777
232		2	-10.677	-10.156	-26.92	
233		3	-10.743	-10.222	-18.005	
234		4	-10.81	-10.288	-9.031	
235		5	-10.876	-10.355	0	
236	4	M10	1	-0.213	-9.672	-34.317
237		2	-0.279	-9.738		
238		3	-0.346	-9.805		

City of Duquoin  
 Development & Permitting Services  
 ISSUED PERMIT

Building Planning  
 Engineering Public Works  
 Fire Traffic

SEE SHEET SHEET 2 FOR ENGINEER OF RECORD SEAL FOR ENCLOSED PLANS.



**Member Section Forces (Continued)**

LC	Member Label	Sec	Axial[k]	Shear[k]	Moment[k-ft]	
239		4	-0.412	-9.871	-8.666	
240		5	-0.479	-9.938	0	
241	4	M11	1	-10.866	6.464	38.981
242		2	-10.8	6.397	33.354	
243		3	-10.733	6.331	27.785	
244		4	-10.667	6.265	22.275	
245		5	-10.6	6.198	16.822	
246	4	M12	1	-1.791	-2.641	-37.489
247		2	-1.374	-3.059	-21.815	
248		3	-0.956	-3.476	-3.845	
249		4	-0.539	-3.893	16.42	
250		5	-0.121	-4.311	38.981	
251	4	M13	1	3.626	-9.317	-33.074
252		2	3.559	-9.383	-24.893	
253		3	3.493	-9.45	-16.653	
254		4	3.426	-9.516	-8.356	
255		5	3.36	-9.583	0	
256	4	M14	1	-4.041	4.058	0.855
257		2	-3.975	3.991	-2.667	
258		3	-3.908	3.925	-6.13	
259		4	-3.842	3.859	-9.536	
260		5	-3.775	3.792	-12.883	
261	4	M15	1	6.237	0	0
262		2	6.257	0	0	
263		3	6.277	0	0	
264		4	6.297	0	0	
265		5	6.318	0	0	
266	4	M16	1	-13.434	0.04	0
267		2	-13.434	0.02	-0.038	
268		3	-13.434	0	-0.05	
269		4	-13.434	-0.02	-0.038	
270		5	-13.434	-0.04	0	
271	4	M17	1	15.216	0	0
272		2	15.236	0	0	
273		3	15.257	0	0	
274		4	15.277	0	0	
275		5	15.297	0	0	
276	4	M18	1	-5.503	0.038	0
277		2	-5.504	0.019	-0.032	
278		3	-5.506	0	-0.043	
279		4	-5.507	-0.019	-0.032	
280		5	-5.509	-0.038	0	
281	4	M19	1	21.166	0	0
282		2	21.186	0	0	
283		3	21.206	0	0	
284		4	21.226	0	0	
285		5	21.247	0	0	
286	5	M1	1	6.511	-6.033	-47.121
287		2	6.227	-5.748	-25.031	
288		3	5.942	-5.464	-4.009	
289		4	5.657	-5.179	15.946	
290		5	5.373	-4.895	34.834	
291	5	M2	1	3.267	-6.11	-47.591
292		2	2.982	-5.825	-25.213	
293		3	2.698	-5.541	-3.902	
294		4	2.413	-5.256		
295		5	2.129	-4.972		

City of Burlington  
 Development & Permitting Services  
 ISSUED PERMIT

Building Planning  
 Engineering Public Works  
 Fire Traffic

SEE SHEET SHEET 2 FOR ENGINEER OF RECORD SEAL FOR ENCLOSED PLANS.



**Member Section Forces (Continued)**

	LC	Member Label	Sec	Axial[k]	Shear[k]	Moment[k-ft]
296	5	M3	1	3.159	-5.696	-45.111
297			2	2.875	-5.412	-24.284
298			3	2.59	-5.127	-4.525
299			4	2.306	-4.842	14.168
300			5	2.021	-4.558	31.793
301	5	M4	1	0	0	0
302			2	-0.09	-0.09	0.054
303			3	-0.18	-0.18	0.214
304			4	-0.27	-0.27	0.482
305			5	-0.36	-0.36	0.856
306	5	M5	1	-8.43	-6.33	16.389
307			2	-8.496	-6.397	21.957
308			3	-8.562	-6.463	27.583
309			4	-8.629	-6.53	33.267
310			5	-8.695	-6.596	39.01
311	5	M6	1	-2.754	-2.826	-8.82
312			2	-2.811	-2.883	-6.679
313			3	-2.868	-2.94	-4.495
314			4	-2.925	-2.997	-2.269
315			5	-2.982	-3.054	0
316	5	M7	1	2.777	3.691	0
317			2	1.499	2.413	-31.662
318			3	0.221	1.135	-50.066
319			4	-1.057	-0.143	-55.212
320			5	11.134	-14.967	0.311
321	5	M8	1	0.277	0.277	0.311
322			2	0.208	0.208	0.175
323			3	0.139	0.138	0.078
324			4	0.069	0.069	0.019
325			5	0	0	0
326	5	M9	1	15.49	8.951	31.793
327			2	15.423	9.017	23.932
328			3	15.357	9.084	16.013
329			4	15.291	9.15	8.036
330			5	15.224	9.217	0
331	5	M10	1	4.431	10.015	35.519
332			2	4.364	10.082	26.726
333			3	4.298	10.148	17.876
334			4	4.231	10.215	8.967
335			5	4.165	10.281	0
336	5	M11	1	9.4	-6.736	-32.861
337			2	9.333	-6.803	-26.938
338			3	9.267	-6.869	-20.957
339			4	9.2	-6.935	-14.917
340			5	9.134	-7.002	-8.82
341	5	M12	1	1.969	4.102	39.01
342			2	1.552	3.684	17.599
343			3	1.134	3.267	-1.517
344			4	0.717	2.85	-18.337
345			5	0.3	2.432	-32.861
346	5	M13	1	-1.5	9.82	34.834
347			2	-1.566	9.886	26.213
348			3	-1.632	9.953	17.533
349			4	-1.699	10.019	8.796
350			5	-1.765	10.085	0
351	5	M14	1	3.521	-4.305	
352			2	3.455	-4.371	

City of Peabody  
 Development & Permitting Services  
 ISSUED PERMIT

Building Planning  
 Engineering Public Works  
 Fire Traffic

SEE SHEET SHEET 2 FOR ENGINEER OF RECORD SEAL FOR ENCLOSED PLANS.



**Member Section Forces (Continued)**

LC	Member Label	Sec	Axial[k]	Shear[k]	Moment[k-ft]
353		3	3.389	-4.438	8.506
354		4	3.322	-4.504	12.418
355		5	3.256	-4.571	16.389
356	5	1	-5.53	0.04	0
357		2	-5.53	0.02	-0.038
358		3	-5.53	0	-0.05
359		4	-5.53	-0.02	-0.038
360		5	-5.53	-0.04	0
361	5	1	15.186	0	0
362		2	15.166	0	0
363		3	15.145	0	0
364		4	15.125	0	0
365		5	15.105	0	0
366	5	1	-12.91	0.04	0
367		2	-12.91	0.02	-0.038
368		3	-12.91	0	-0.05
369		4	-12.91	-0.02	-0.038
370		5	-12.91	-0.04	0
371	5	1	8.944	-0.003	0
372		2	8.925	-0.001	0.002
373		3	8.907	0	0.003
374		4	8.888	0.001	0.002
375		5	8.869	0.003	0
376	5	1	-19.088	0.04	0
377		2	-19.088	0.02	-0.038
378		3	-19.088	0	-0.05
379		4	-19.088	-0.02	-0.038
380		5	-19.088	-0.04	0

**Member Section Stresses**

LC	Member Label	Sec	Axial[ksi]	Shear[ksi]	Top Bending[ksi]	Bot Bending[ksi]	
1	1	M1	1	0.141	-0.008	0.37	-0.37
2			2	0.128	-0.008	0.184	-0.184
3			3	0.115	-0.008	-0.002	0.002
4			4	0.103	-0.008	-0.189	0.189
5			5	0.09	-0.008	-0.375	0.375
6	1	M2	1	0.244	-0.006	0.301	-0.301
7			2	0.231	-0.006	0.158	-0.158
8			3	0.218	-0.006	0.014	-0.014
9			4	0.205	-0.006	-0.129	0.129
10			5	0.193	-0.006	-0.273	0.273
11	1	M3	1	0.196	0.013	-0.455	0.455
12			2	0.183	0.013	-0.127	0.127
13			3	0.17	0.013	0.201	-0.201
14			4	0.157	0.013	0.53	-0.53
15			5	0.145	0.013	0.858	-0.858
16	1	M4	1	0	0	0	0
17			2	0	-0.012	-0.004	0.004
18			3	0	-0.023	-0.018	0.018
19			4	0	-0.035	-0.04	0.04
20			5	0	-0.047	-0.07	0.07
21	1	M5	1	-0.023	0.052	-0.146	0.146
22			2	-0.023	0.044	-0.119	0.119
23			3	-0.023	0.035	-0.097	0.097
24			4	-0.023	0.027	-0.08	0.08



SEE SHEET SHEET 2 FOR ENGINEER OF RECORD SEAL FOR ENCLOSED PLANS.



Company : AHBL  
 Designer : ADM  
 Job Number : 2220760.20  
 Model Name : Bridge Crane

Oct 26, 2022  
 4:29 PM  
 Checked By: ADM

**Member Section Stresses (Continued)**

LC	Member Label	Sec	Axial[ksi]	Shear[ksi]	Top Bending[ksi]	Bot Bending[ksi]
25		5	-0.023	0.018	-0.067	0.067
26	1 M6	1	-0.041	0.188	-0.33	0.33
27		2	-0.041	0.18	-0.242	0.242
28		3	-0.041	0.173	-0.158	0.158
29		4	-0.041	0.166	-0.077	0.077
30		5	-0.041	0.158	0	0
31	1 M7	1	0.006	0.166	0	0
32		2	0.006	0.081	0.52	-0.79
33		3	0.006	-0.005	0.68	-1.033
34		4	0.006	-0.09	0.481	-0.73
35		5	-0.016	-0.126	-0.008	0.013
36	1 M8	1	0	0.018	-0.008	0.013
37		2	0	0.014	-0.005	0.007
38		3	0	0.009	-0.002	0.003
39		4	0	0.005	-0.001	0.001
40		5	0	0	0	0
41	1 M9	1	0.109	-0.038	0.858	-0.858
42		2	0.106	-0.038	0.643	-0.643
43		3	0.103	-0.038	0.429	-0.429
44		4	0.1	-0.038	0.214	-0.214
45		5	0.097	-0.038	0	0
46	1 M10	1	0.095	0.012	-0.273	0.273
47		2	0.092	0.012	-0.205	0.205
48		3	0.089	0.012	-0.136	0.136
49		4	0.086	0.012	-0.068	0.068
50		5	0.083	0.012	0	0
51	1 M11	1	-0.032	-0.017	-0.254	0.254
52		2	-0.032	-0.025	-0.266	0.266
53		3	-0.032	-0.034	-0.282	0.282
54		4	-0.032	-0.042	-0.304	0.304
55		5	-0.032	-0.051	-0.33	0.33
56	1 M12	1	0.005	0.095	-0.067	0.067
57		2	0.005	0.041	0.169	-0.169
58		3	0.005	-0.013	0.216	-0.216
59		4	0.005	-0.067	0.075	-0.075
60		5	0.005	-0.121	-0.254	0.254
61	1 M13	1	0.048	0.016	-0.375	0.375
62		2	0.045	0.016	-0.281	0.281
63		3	0.042	0.016	-0.187	0.187
64		4	0.039	0.016	-0.094	0.094
65		5	0.036	0.016	0	0
66	1 M14	1	-0.012	-0.017	-0.07	0.07
67		2	-0.012	-0.025	-0.082	0.082
68		3	-0.012	-0.034	-0.098	0.098
69		4	-0.012	-0.043	-0.12	0.12
70		5	-0.012	-0.051	-0.146	0.146
71	1 M15	1	0.102	0.014	0	0
72		2	0.105	0.007	0.054	-0.144
73		3	0.108	0	0.072	-0.191
74		4	0.111	-0.007	0.054	-0.144
75		5	0.114	-0.014	0	0
76	1 M16	1	0.264	0.014	0	0
77		2	0.261	0.007	0.054	-0.144
78		3	0.258	0	0.072	-0.191
79		4	0.255	-0.007	0.054	-0.144
80		5	0.252	-0.014	0	0
81	1 M17	1	0.343	0.014	0	0

City of Puget Sound  
 Development & Permitting Services  
 ISSUED PERMIT

Building - Planning  
 Engineering - Public Works  
 Fire - Traffic

SEE SHEET SHEET 2 FOR ENGINEER OF RECORD SEAL FOR ENCLOSED PLANS.



**Member Section Stresses (Continued)**

LC	Member Label	Sec	Axial[ksi]	Shear[ksi]	Top Bending[ksi]	Bot Bending[ksi]
82		2	0.346	0.007	0.054	-0.144
83		3	0.349	0	0.072	-0.191
84		4	0.352	-0.007	0.054	-0.144
85		5	0.355	-0.014	0	0
86	1	M18	1	0.505	0.012	0
87		2	0.502	0.006	0.043	-0.115
88		3	0.499	0	0.057	-0.153
89		4	0.496	-0.006	0.043	-0.115
90		5	0.493	-0.012	0	0
91	1	M19	1	0.312	0.014	0
92		2	0.315	0.007	0.054	-0.144
93		3	0.318	0	0.072	-0.191
94		4	0.321	-0.007	0.054	-0.144
95		5	0.324	-0.014	0	0
96	2	M1	1	0.141	-0.008	0.37
97		2	0.128	-0.008	0.184	-0.184
98		3	0.115	-0.008	-0.002	0.002
99		4	0.103	-0.008	-0.189	0.189
100		5	0.09	-0.008	-0.375	0.375
101	2	M2	1	0.244	-0.006	0.301
102		2	0.231	-0.006	0.158	-0.158
103		3	0.218	-0.006	0.014	-0.014
104		4	0.205	-0.006	-0.129	0.129
105		5	0.193	-0.006	-0.273	0.273
106	2	M3	1	0.196	0.013	-0.455
107		2	0.183	0.013	-0.127	0.127
108		3	0.17	0.013	0.201	-0.201
109		4	0.157	0.013	0.53	-0.53
110		5	0.145	0.013	0.858	-0.858
111	2	M4	1	0	0	0
112		2	0	-0.012	-0.004	0.004
113		3	0	-0.023	-0.018	0.018
114		4	0	-0.035	-0.04	0.04
115		5	0	-0.047	-0.07	0.07
116	2	M5	1	-0.023	0.052	-0.146
117		2	-0.023	0.044	-0.119	0.119
118		3	-0.023	0.035	-0.097	0.097
119		4	-0.023	0.027	-0.08	0.08
120		5	-0.023	0.018	-0.067	0.067
121	2	M6	1	-0.041	0.188	-0.33
122		2	-0.041	0.18	-0.242	0.242
123		3	-0.041	0.173	-0.158	0.158
124		4	-0.041	0.166	-0.077	0.077
125		5	-0.041	0.158	0	0
126	2	M7	1	0.006	0.166	0
127		2	0.006	0.081	0.52	-0.79
128		3	0.006	-0.005	0.68	-1.033
129		4	0.006	-0.09	0.481	-0.73
130		5	-0.016	-0.126	-0.008	0.013
131	2	M8	1	0	0.018	-0.008
132		2	0	0.014	-0.005	0.007
133		3	0	0.009	-0.002	0.003
134		4	0	0.005	-0.001	0.001
135		5	0	0	0	0
136	2	M9	1	0.109	-0.038	0.858
137		2	0.106	-0.038	0.643	-0.858
138		3	0.103	-0.038	0.429	-0.858



SEE SHEET SHEET 2 FOR ENGINEER OF RECORD SEAL FOR ENCLOSED PLANS.



**Member Section Stresses (Continued)**

LC	Member Label	Sec	Axial[ksi]	Shear[ksi]	Top Bending[ksi]	Bot Bending[ksi]
139		4	0.1	-0.038	0.214	-0.214
140		5	0.097	-0.038	0	0
141	2 M10	1	0.095	0.012	-0.273	0.273
142		2	0.092	0.012	-0.205	0.205
143		3	0.089	0.012	-0.136	0.136
144		4	0.086	0.012	-0.068	0.068
145		5	0.083	0.012	0	0
146	2 M11	1	-0.032	-0.017	-0.254	0.254
147		2	-0.032	-0.025	-0.266	0.266
148		3	-0.032	-0.034	-0.282	0.282
149		4	-0.032	-0.042	-0.304	0.304
150		5	-0.032	-0.051	-0.33	0.33
151	2 M12	1	0.005	0.095	-0.067	0.067
152		2	0.005	0.041	0.169	-0.169
153		3	0.005	-0.013	0.216	-0.216
154		4	0.005	-0.067	0.075	-0.075
155		5	0.005	-0.121	-0.254	0.254
156	2 M13	1	0.048	0.016	-0.375	0.375
157		2	0.045	0.016	-0.281	0.281
158		3	0.042	0.016	-0.187	0.187
159		4	0.039	0.016	-0.094	0.094
160		5	0.036	0.016	0	0
161	2 M14	1	-0.012	-0.017	-0.07	0.07
162		2	-0.012	-0.025	-0.082	0.082
163		3	-0.012	-0.034	-0.098	0.098
164		4	-0.012	-0.043	-0.12	0.12
165		5	-0.012	-0.051	-0.146	0.146
166	2 M15	1	0.102	0.014	0	0
167		2	0.105	0.007	0.054	-0.144
168		3	0.108	0	0.072	-0.191
169		4	0.111	-0.007	0.054	-0.144
170		5	0.114	-0.014	0	0
171	2 M16	1	0.264	0.014	0	0
172		2	0.261	0.007	0.054	-0.144
173		3	0.258	0	0.072	-0.191
174		4	0.255	-0.007	0.054	-0.144
175		5	0.252	-0.014	0	0
176	2 M17	1	0.343	0.014	0	0
177		2	0.346	0.007	0.054	-0.144
178		3	0.349	0	0.072	-0.191
179		4	0.352	-0.007	0.054	-0.144
180		5	0.355	-0.014	0	0
181	2 M18	1	0.505	0.012	0	0
182		2	0.502	0.006	0.043	-0.115
183		3	0.499	0	0.057	-0.153
184		4	0.496	-0.006	0.043	-0.115
185		5	0.493	-0.012	0	0
186	2 M19	1	0.312	0.014	0	0
187		2	0.315	0.007	0.054	-0.144
188		3	0.318	0	0.072	-0.191
189		4	0.321	-0.007	0.054	-0.144
190		5	0.324	-0.014	0	0
191	4 M1	1	-0.01	0.388	-19.714	19.714
192		2	-0.023	0.369	-10.5	10.5
193		3	-0.036	0.35	-1.75	1.75
194		4	-0.049	0.331	6.537	
195		5	-0.061	0.312	14.361	

City of Dayton  
 Development & Permitting Services  
 ISSUED PERMITS  
 Building Planning  
 Engineering Public Works  
 Fire Traffic

SEE SHEET SHEET 2 FOR ENGINEER OF RECORD SEAL FOR ENCLOSED PLANS.





**Member Section Stresses (Continued)**

LC	Member Label	Sec	Axial[ksi]	Shear[ksi]	Top Bending[ksi]	Bot Bending[ksi]	
196	4	M2	1	0.341	0.397	-20.081	20.081
197			2	0.328	0.378	-10.641	10.641
198			3	0.315	0.359	-1.664	1.664
199			4	0.303	0.34	6.85	-6.85
200			5	0.29	0.321	14.901	-14.901
201	4	M3	1	0.25	0.408	-20.51	20.51
202			2	0.237	0.389	-10.804	10.804
203			3	0.224	0.37	-1.561	1.561
204			4	0.211	0.351	7.218	-7.218
205			5	0.199	0.332	15.535	-15.535
206	4	M4	1	0	0	0	0
207			2	0.004	-0.012	-0.004	0.004
208			3	0.008	-0.023	-0.018	0.018
209			4	0.012	-0.035	-0.039	0.039
210			5	0.016	-0.047	-0.07	0.07
211	4	M5	1	0.332	0.926	1.058	-1.058
212			2	0.335	0.917	1.57	-1.57
213			3	0.338	0.909	2.077	-2.077
214			4	0.341	0.9	2.58	-2.58
215			5	0.344	0.892	3.078	-3.078
216	4	M6	1	0.042	0.74	-1.381	1.381
217			2	0.045	0.732	-1.031	1.031
218			3	0.047	0.725	-0.684	0.684
219			4	0.05	0.718	-0.34	0.34
220			5	0.052	0.71	0	0
221	4	M7	1	-0.066	0.086	0	0
222			2	-0.031	0	0.182	-0.276
223			3	0.005	-0.085	0.004	-0.006
224			4	0.04	-0.17	-0.533	0.811
225			5	-0.338	0.744	-0.008	0.013
226	4	M8	1	-0.008	0.018	-0.008	0.013
227			2	-0.006	0.014	-0.005	0.007
228			3	-0.004	0.009	-0.002	0.003
229			4	-0.002	0.005	-0.001	0.001
230			5	0	0	0	0
231	4	M9	1	-0.476	-0.674	15.535	-15.535
232			2	-0.479	-0.679	11.689	-11.689
233			3	-0.482	-0.683	7.818	-7.818
234			4	-0.485	-0.688	3.922	-3.922
235			5	-0.488	-0.692	0	0
236	4	M10	1	-0.01	-0.647	14.901	-14.901
237			2	-0.013	-0.651	11.213	-11.213
238			3	-0.016	-0.655	7.501	-7.501
239			4	-0.018	-0.66	3.763	-3.763
240			5	-0.021	-0.664	0	0
241	4	M11	1	-0.487	0.836	-3.201	3.201
242			2	-0.484	0.827	-2.739	2.739
243			3	-0.481	0.818	-2.281	2.281
244			4	-0.478	0.81	-1.829	1.829
245			5	-0.475	0.801	-1.381	1.381
246	4	M12	1	-0.08	-0.341	3.078	-3.078
247			2	-0.062	-0.395	1.791	-1.791
248			3	-0.043	-0.449	0.316	-0.316
249			4	-0.024	-0.503	-1.348	1.348
250			5	-0.005	-0.557	-3.201	3.201
251	4	M13	1	0.163	-0.623	14.361	-14.361
252			2	0.16	-0.627	10.809	-10.809

SEE SHEET SHEET 2 FOR ENGINEER OF RECORD SEAL FOR ENCLOSED PLANS.

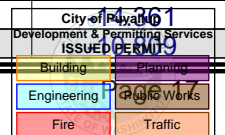



**Member Section Stresses (Continued)**

LC	Member Label	Sec	Axial[ksi]	Shear[ksi]	Top Bending[ksi]	Bot Bending[ksi]
253		3	0.157	-0.632	7.231	-7.231
254		4	0.154	-0.636	3.628	-3.628
255		5	0.151	-0.641	0	0
256	4 M14	1	-0.181	0.525	-0.07	0.07
257		2	-0.178	0.516	0.219	-0.219
258		3	-0.175	0.507	0.503	-0.503
259		4	-0.172	0.499	0.783	-0.783
260		5	-0.169	0.49	1.058	-1.058
261	4 M15	1	1.834	0	0	0
262		2	1.84	0	0	0
263		3	1.846	0	0	0
264		4	1.852	0	0	0
265		5	1.858	0	0	0
266	4 M16	1	-3.951	0.028	0	0
267		2	-3.951	0.014	0.108	-0.287
268		3	-3.951	0	0.143	-0.383
269		4	-3.951	-0.014	0.108	-0.287
270		5	-3.951	-0.028	0	0
271	4 M17	1	4.475	0	0	0
272		2	4.481	0	0	0
273		3	4.487	0	0	0
274		4	4.493	0	0	0
275		5	4.499	0	0	0
276	4 M18	1	-1.618	0.026	0	0
277		2	-1.619	0.013	0.093	-0.248
278		3	-1.619	0	0.124	-0.331
279		4	-1.62	-0.013	0.093	-0.248
280		5	-1.62	-0.026	0	0
281	4 M19	1	6.225	0	0	0
282		2	6.231	0	0	0
283		3	6.237	0	0	0
284		4	6.243	0	0	0
285		5	6.249	0	0	0
286	5 M1	1	0.292	-0.403	20.46	-20.46
287		2	0.279	-0.384	10.869	-10.869
288		3	0.266	-0.365	1.741	-1.741
289		4	0.254	-0.346	-6.924	6.924
290		5	0.241	-0.327	-15.125	15.125
291	5 M2	1	0.146	-0.408	20.665	-20.665
292		2	0.134	-0.389	10.948	-10.948
293		3	0.121	-0.37	1.694	-1.694
294		4	0.108	-0.351	-7.096	7.096
295		5	0.095	-0.332	-15.423	15.423
296	5 M3	1	0.142	-0.381	19.588	-19.588
297		2	0.129	-0.362	10.545	-10.545
298		3	0.116	-0.343	1.965	-1.965
299		4	0.103	-0.324	-6.152	6.152
300		5	0.091	-0.305	-13.805	13.805
301	5 M4	1	0	0	0	0
302		2	-0.004	-0.012	-0.004	0.004
303		3	-0.008	-0.023	-0.018	0.018
304		4	-0.012	-0.035	-0.04	0.04
305		5	-0.016	-0.047	-0.07	0.07
306	5 M5	1	-0.378	-0.818	-1.346	1.346
307		2	-0.381	-0.827	-1.803	1.803
308		3	-0.384	-0.836	-2.265	
309		4	-0.387	-0.844	-2.731	

SEE SHEET SHEET 2 FOR ENGINEER OF RECORD SEAL FOR ENCLOSED PLANS.

City of Pueblo  
 Development & Permitting Services  
 ISSUED PERMIT

Building Planning  
 Engineering Public Works  
 Fire Traffic



**Member Section Stresses (Continued)**

LC	Member Label	Sec	Axial[ksi]	Shear[ksi]	Top Bending[ksi]	Bot Bending[ksi]
310		5	-0.39	-0.853	-3.203	3.203
311	5	M6	1	-0.124	-0.365	0.724
312		2	-0.126	-0.373	0.548	-0.548
313		3	-0.129	-0.38	0.369	-0.369
314		4	-0.131	-0.387	0.186	-0.186
315		5	-0.134	-0.395	0	0
316	5	M7	1	0.077	0.246	0
317		2	0.041	0.161	0.858	-1.305
318		3	0.006	0.076	1.357	-2.063
319		4	-0.029	-0.01	1.497	-2.275
320		5	0.308	-0.998	-0.008	0.013
321	5	M8	1	0.008	0.018	-0.008
322		2	0.006	0.014	-0.005	0.007
323		3	0.004	0.009	-0.002	0.003
324		4	0.002	0.005	-0.001	0.001
325		5	0	0	0	0
326	5	M9	1	0.695	0.598	-13.805
327		2	0.692	0.603	-10.392	10.392
328		3	0.689	0.607	-6.953	6.953
329		4	0.686	0.612	-3.489	3.489
330		5	0.683	0.616	0	0
331	5	M10	1	0.199	0.669	-15.423
332		2	0.196	0.674	-11.605	11.605
333		3	0.193	0.678	-7.762	7.762
334		4	0.19	0.683	-3.894	3.894
335		5	0.187	0.687	0	0
336	5	M11	1	0.422	-0.871	2.698
337		2	0.419	-0.879	2.212	-2.212
338		3	0.416	-0.888	1.721	-1.721
339		4	0.413	-0.897	1.225	-1.225
340		5	0.41	-0.905	0.724	-0.724
341	5	M12	1	0.088	0.53	-3.203
342		2	0.07	0.476	-1.445	1.445
343		3	0.051	0.422	0.125	-0.125
344		4	0.032	0.368	1.506	-1.506
345		5	0.013	0.314	2.698	-2.698
346	5	M13	1	-0.067	0.656	-15.125
347		2	-0.07	0.661	-11.382	11.382
348		3	-0.073	0.665	-7.613	7.613
349		4	-0.076	0.67	-3.819	3.819
350		5	-0.079	0.674	0	0
351	5	M14	1	0.158	-0.557	-0.07
352		2	0.155	-0.565	-0.382	0.382
353		3	0.152	-0.574	-0.698	0.698
354		4	0.149	-0.582	-1.02	1.02
355		5	0.146	-0.591	-1.346	1.346
356	5	M15	1	-1.627	0.028	0
357		2	-1.627	0.014	0.108	-0.287
358		3	-1.627	0	0.143	-0.383
359		4	-1.627	-0.014	0.108	-0.287
360		5	-1.627	-0.028	0	0
361	5	M16	1	4.466	0	0
362		2	4.46	0	0	0
363		3	4.454	0	0	0
364		4	4.449	0	0	0
365		5	4.443	0	0	0
366	5	M17	1	-3.797	0.028	0

City of Puget Sound  
 Development & Permitting Services  
 ISSUED PERMIT

Building Planning  
 Engineering Public Works  
 Fire Traffic

SEE SHEET SHEET 2 FOR ENGINEER OF RECORD SEAL FOR ENCLOSED PLANS.



**Member Section Stresses (Continued)**

LC	Member Label	Sec	Axial[ksi]	Shear[ksi]	Top Bending[ksi]	Bot Bending[ksi]
367		2	-3.797	0.014	0.108	-0.287
368		3	-3.797	0	0.143	-0.383
369		4	-3.797	-0.014	0.108	-0.287
370		5	-3.797	-0.028	0	0
371	5	1	2.631	-0.002	0	0
372		2	2.625	-0.001	-0.007	0.019
373		3	2.62	0	-0.01	0.025
374		4	2.614	0.001	-0.007	0.019
375		5	2.609	0.002	0	0
376	5	1	-5.614	0.028	0	0
377		2	-5.614	0.014	0.108	-0.287
378		3	-5.614	0	0.143	-0.383
379		4	-5.614	-0.014	0.108	-0.287
380		5	-5.614	-0.028	0	0

**Member Section Deflections Service**

LC	Member Label	Sec	x [in]	y [in]	(n) L/y' Ratio	
1	1	M1	1	0	NC	
2			2	0	0.002	NC
3			3	0	0.008	NC
4			4	-0.001	0.013	NC
5			5	-0.001	0.016	NC
6	1	M2	1	0	0	NC
7			2	0	0.002	NC
8			3	-0.001	0.007	NC
9			4	-0.001	0.011	NC
10			5	-0.002	0.014	NC
11	1	M3	1	0	0	NC
12			2	0	-0.003	NC
13			3	-0.001	-0.008	NC
14			4	-0.001	-0.009	NC
15			5	-0.001	-0.002	NC
16	1	M4	1	-0.014	0.002	NC
17			2	-0.014	0.002	NC
18			3	-0.014	0.001	NC
19			4	-0.014	0.001	NC
20			5	-0.014	0.001	NC
21	1	M5	1	-0.014	-0.001	NC
22			2	-0.014	-0.002	NC
23			3	-0.014	-0.002	NC
24			4	-0.014	-0.003	NC
25			5	-0.014	-0.004	NC
26	1	M6	1	-0.014	-0.002	NC
27			2	-0.014	-0.002	NC
28			3	-0.014	-0.003	NC
29			4	-0.014	-0.003	NC
30			5	-0.014	-0.004	NC
31	1	M7	1	-0.014	-0.004	NC
32			2	-0.014	-0.048	NC
33			3	-0.014	-0.066	7879
34			4	-0.014	-0.047	NC
35			5	-0.014	-0.002	NC
36	1	M8	1	-0.014	-0.002	NC
37			2	-0.014	0.001	NC
38			3	-0.014	0.004	NC

City of Puyallup  
 Development & Permitting Services  
 ISSUED PERMIT

Building Planning  
 Engineering Public Works  
 Fire Traffic

SEE SHEET SHEET 2 FOR ENGINEER OF RECORD SEAL FOR ENCLOSED PLANS.



**Member Section Deflections Service (Continued)**

LC	Member Label	Sec	x [in]	y [in]	(n) L/y' Ratio
39		4	-0.014	0.007	3358
40		5	-0.014	0.009	2519
41	1 M9	1	-0.001	-0.002	NC
42		2	-0.001	0.001	NC
43		3	-0.001	0.005	5775
44		4	-0.001	0.009	3634
45		5	-0.002	0.014	2620
46	1 M10	1	-0.002	0.014	NC
47		2	-0.002	0.014	NC
48		3	-0.002	0.014	NC
49		4	-0.002	0.014	NC
50		5	-0.002	0.014	NC
51	1 M11	1	-0.014	-0.003	NC
52		2	-0.014	-0.002	NC
53		3	-0.014	-0.002	NC
54		4	-0.014	-0.002	NC
55		5	-0.014	-0.002	NC
56	1 M12	1	-0.014	-0.004	NC
57		2	-0.014	-0.008	NC
58		3	-0.014	-0.01	NC
59		4	-0.014	-0.007	NC
60		5	-0.014	-0.003	NC
61	1 M13	1	-0.001	0.016	NC
62		2	-0.001	0.015	NC
63		3	-0.001	0.015	NC
64		4	-0.001	0.014	NC
65		5	-0.001	0.014	NC
66	1 M14	1	-0.014	0.001	NC
67		2	-0.014	0	NC
68		3	-0.014	0	NC
69		4	-0.014	0	NC
70		5	-0.014	-0.001	NC
71	1 M15	1	-0.01	-0.009	NC
72		2	-0.01	-0.011	NC
73		3	-0.01	-0.012	NC
74		4	-0.01	-0.012	NC
75		5	-0.01	-0.012	NC
76	1 M16	1	-0.012	0.01	NC
77		2	-0.012	0.009	NC
78		3	-0.012	0.007	NC
79		4	-0.012	0.007	NC
80		5	-0.012	0.007	NC
81	1 M17	1	-0.008	-0.011	NC
82		2	-0.008	-0.012	NC
83		3	-0.008	-0.012	NC
84		4	-0.009	-0.012	NC
85		5	-0.009	-0.011	NC
86	1 M18	1	-0.01	0.01	NC
87		2	-0.011	0.009	NC
88		3	-0.011	0.008	NC
89		4	-0.011	0.008	NC
90		5	-0.012	0.008	NC
91	1 M19	1	0.003	-0.023	NC
92		2	0.003	-0.018	NC
93		3	0.003	-0.012	NC
94		4	0.003	-0.006	NC
95		5	0.003	0.001	NC

City of Puallup  
 Development & Permitting Services  
 ISSUED PERMIT

Building Planning  
 Engineering Public Works  
 Fire Traffic

SEE SHEET SHEET 2 FOR ENGINEER OF RECORD SEAL FOR ENCLOSED PLANS.



**Member Section Deflections Service (Continued)**

	LC	Member Label	Sec	x [in]	y [in]	(n) L/V Ratio
96	2	M1	1	0	0	NC
97			2	0	0.002	NC
98			3	0	0.008	NC
99			4	-0.001	0.013	NC
100			5	-0.001	0.016	NC
101	2	M2	1	0	0	NC
102			2	0	0.002	NC
103			3	-0.001	0.007	NC
104			4	-0.001	0.011	NC
105			5	-0.002	0.014	NC
106	2	M3	1	0	0	NC
107			2	0	-0.003	NC
108			3	-0.001	-0.008	NC
109			4	-0.001	-0.009	NC
110			5	-0.001	-0.002	NC
111	2	M4	1	-0.014	0.002	NC
112			2	-0.014	0.002	NC
113			3	-0.014	0.001	NC
114			4	-0.014	0.001	NC
115			5	-0.014	0.001	NC
116	2	M5	1	-0.014	-0.001	NC
117			2	-0.014	-0.002	NC
118			3	-0.014	-0.002	NC
119			4	-0.014	-0.003	NC
120			5	-0.014	-0.004	NC
121	2	M6	1	-0.014	-0.002	NC
122			2	-0.014	-0.002	NC
123			3	-0.014	-0.003	NC
124			4	-0.014	-0.003	NC
125			5	-0.014	-0.004	NC
126	2	M7	1	-0.014	-0.004	NC
127			2	-0.014	-0.048	NC
128			3	-0.014	-0.066	7879
129			4	-0.014	-0.047	NC
130			5	-0.014	-0.002	NC
131	2	M8	1	-0.014	-0.002	NC
132			2	-0.014	0.001	NC
133			3	-0.014	0.004	5037
134			4	-0.014	0.007	3358
135			5	-0.014	0.009	2519
136	2	M9	1	-0.001	-0.002	NC
137			2	-0.001	0.001	NC
138			3	-0.001	0.005	5775
139			4	-0.001	0.009	3634
140			5	-0.002	0.014	2620
141	2	M10	1	-0.002	0.014	NC
142			2	-0.002	0.014	NC
143			3	-0.002	0.014	NC
144			4	-0.002	0.014	NC
145			5	-0.002	0.014	NC
146	2	M11	1	-0.014	-0.003	NC
147			2	-0.014	-0.002	NC
148			3	-0.014	-0.002	NC
149			4	-0.014	-0.002	NC
150			5	-0.014	-0.002	NC
151	2	M12	1	-0.014	-0.004	NC
152			2	-0.014	-0.008	NC

City of Pullman  
 Development & Permitting Services  
 ISSUED PERMIT

Building Planning  
 Engineering Public Works  
 Fire Traffic

SEE SHEET SHEET 2 FOR ENGINEER OF RECORD SEAL FOR ENCLOSED PLANS.



**Member Section Deflections Service (Continued)**

LC	Member Label	Sec	x [in]	y [in]	(n) L/y' Ratio
153		3	-0.014	-0.01	NC
154		4	-0.014	-0.007	NC
155		5	-0.014	-0.003	NC
156	2 M13	1	-0.001	0.016	NC
157		2	-0.001	0.015	NC
158		3	-0.001	0.015	NC
159		4	-0.001	0.014	NC
160		5	-0.001	0.014	NC
161	2 M14	1	-0.014	0.001	NC
162		2	-0.014	0	NC
163		3	-0.014	0	NC
164		4	-0.014	0	NC
165		5	-0.014	-0.001	NC
166	2 M15	1	-0.01	-0.009	NC
167		2	-0.01	-0.011	NC
168		3	-0.01	-0.012	NC
169		4	-0.01	-0.012	NC
170		5	-0.01	-0.012	NC
171	2 M16	1	-0.012	0.01	NC
172		2	-0.012	0.009	NC
173		3	-0.012	0.007	NC
174		4	-0.012	0.007	NC
175		5	-0.012	0.007	NC
176	2 M17	1	-0.008	-0.011	NC
177		2	-0.008	-0.012	NC
178		3	-0.008	-0.012	NC
179		4	-0.009	-0.012	NC
180		5	-0.009	-0.011	NC
181	2 M18	1	-0.01	0.01	NC
182		2	-0.011	0.009	NC
183		3	-0.011	0.008	NC
184		4	-0.011	0.008	NC
185		5	-0.012	0.008	NC
186	2 M19	1	0.003	-0.023	NC
187		2	0.003	-0.018	NC
188		3	0.003	-0.012	NC
189		4	0.003	-0.006	NC
190		5	0.003	0.001	NC
191	4 M1	1	0	0	NC
192		2	0	-0.133	1351
193		3	0	-0.434	415
194		4	0	-0.762	236
195		5	0	-0.988	182
196	4 M2	1	0	0	NC
197		2	-0.001	-0.136	1328
198		3	-0.001	-0.441	408
199		4	-0.002	-0.773	233
200		5	-0.002	-0.996	180
201	4 M3	1	0	0	NC
202		2	0	-0.138	1301
203		3	-0.001	-0.449	401
204		4	-0.001	-0.784	229
205		5	-0.002	-1.006	179
206	4 M4	1	1.041	0.108	925
207		2	1.041	0.093	1233
208		3	1.041	0.077	
209		4	1.041	0.062	

City of Chicago  
 Development & Permitting Services  
 ISSUED PERMIT

Building Planning  
 Engineering Public Works  
 Fire Traffic

SEE SHEET SHEET 2 FOR ENGINEER OF RECORD SEAL FOR ENCLOSED PLANS.



**Member Section Deflections Service (Continued)**

LC	Member Label	Sec	x [in]	y [in]	(n) L/V Ratio
210		5	1.041	0.046	NC
211	4 M5	1	1.041	0	NC
212		2	1.041	-0.011	NC
213		3	1.041	-0.021	NC
214		4	1.041	-0.03	NC
215		5	1.041	-0.038	NC
216	4 M6	1	1.042	-0.002	NC
217		2	1.042	-0.01	NC
218		3	1.042	-0.019	NC
219		4	1.042	-0.027	NC
220		5	1.042	-0.036	NC
221	4 M7	1	1.042	-0.036	NC
222		2	1.042	-0.025	NC
223		3	1.042	-0.005	NC
224		4	1.042	0.014	NC
225		5	1.042	-0.001	NC
226	4 M8	1	1.042	-0.001	NC
227		2	1.042	-0.003	NC
228		3	1.042	-0.004	8039
229		4	1.043	-0.006	5358
230		5	1.043	-0.008	4018
231	4 M9	1	-0.002	-1.006	NC
232		2	-0.002	-1.027	3560
233		3	-0.001	-1.038	3112
234		4	-0.001	-1.042	4975
235		5	-0.001	-1.042	NC
236	4 M10	1	-0.002	-0.996	NC
237		2	-0.002	-1.019	3711
238		3	-0.002	-1.032	3244
239		4	-0.002	-1.039	5186
240		5	-0.002	-1.042	NC
241	4 M11	1	1.041	0.026	NC
242		2	1.041	0.021	NC
243		3	1.041	0.014	NC
244		4	1.042	0.006	NC
245		5	1.042	-0.002	NC
246	4 M12	1	1.041	-0.038	NC
247		2	1.041	-0.046	NC
248		3	1.041	-0.016	NC
249		4	1.041	0.019	NC
250		5	1.041	0.026	NC
251	4 M13	1	0	-0.988	NC
252		2	0	-1.012	3850
253		3	0	-1.027	3365
254		4	0	-1.036	5379
255		5	0	-1.041	NC
256	4 M14	1	1.041	0.046	NC
257		2	1.041	0.035	NC
258		3	1.041	0.023	NC
259		4	1.041	0.011	NC
260		5	1.041	0	NC
261	4 M15	1	0.703	0.769	NC
262		2	0.702	0.751	NC
263		3	0.701	0.734	NC
264		4	0.7	0.716	NC
265		5	0.698	0.699	NC
266	4 M16	1	0.699	-0.698	NC

City of Fullerton  
 Development & Permitting Services  
 ISSUED PERMIT

Building Planning  
 Engineering Traffic  
 Fire

SEE SHEET SHEET 2 FOR ENGINEER OF RECORD SEAL FOR ENCLOSED PLANS.





**Member Section Deflections Service (Continued)**

LC	Member Label	Sec	x [in]	y [in]	(n) L/y' Ratio
267		2	0.701	-0.716	NC
268		3	0.704	-0.733	NC
269		4	0.706	-0.748	NC
270		5	0.709	-0.763	NC
271	4 M17	1	0.718	0.754	NC
272		2	0.715	0.742	NC
273		3	0.712	0.729	NC
274		4	0.709	0.716	NC
275		5	0.706	0.703	NC
276	4 M18	1	0.647	-0.758	NC
277		2	0.648	-0.774	NC
278		3	0.649	-0.788	NC
279		4	0.65	-0.802	NC
280		5	0.65	-0.815	NC
281	4 M19	1	0.729	0.745	NC
282		2	0.725	0.736	NC
283		3	0.721	0.728	NC
284		4	0.717	0.719	NC
285		5	0.713	0.71	NC
286	5 M1	1	0	0	NC
287		2	-0.001	0.138	1303
288		3	-0.001	0.449	400
289		4	-0.002	0.789	228
290		5	-0.002	1.019	176
291	5 M2	1	0	0	NC
292		2	0	0.139	1290
293		3	0	0.453	397
294		4	-0.001	0.795	226
295		5	-0.001	1.024	175
296	5 M3	1	0	0	NC
297		2	0	0.133	1357
298		3	0	0.433	415
299		4	-0.001	0.765	235
300		5	-0.001	1.001	179
301	5 M4	1	-1.068	-0.103	978
302		2	-1.068	-0.089	1305
303		3	-1.068	-0.074	1959
304		4	-1.068	-0.059	3923
305		5	-1.068	-0.045	NC
306	5 M5	1	-1.068	-0.002	NC
307		2	-1.068	0.008	NC
308		3	-1.068	0.016	NC
309		4	-1.068	0.024	NC
310		5	-1.067	0.03	NC
311	5 M6	1	-1.069	-0.001	NC
312		2	-1.069	0.006	NC
313		3	-1.069	0.014	NC
314		4	-1.069	0.021	NC
315		5	-1.069	0.029	NC
316	5 M7	1	-1.069	0.029	NC
317		2	-1.069	-0.072	5327
318		3	-1.069	-0.127	3545
319		4	-1.069	-0.107	4408
320		5	-1.069	-0.002	NC
321	5 M8	1	-1.069	-0.002	NC
322		2	-1.069	0.005	NC
323		3	-1.069	0.012	NC

City of Phoenix  
 Development & Permitting Services  
 ISSUED PERMIT

Building Planning  
 Engineering Traffic

SEE SHEET SHEET 2 FOR ENGINEER OF RECORD SEAL FOR ENCLOSED PLANS.



**Member Section Deflections Service (Continued)**

LC	Member Label	Sec	x [in]	y [in]	(n) L/y' Ratio
324		4	-1.069	0.019	1277
325		5	-1.069	0.026	957
326	5 M9	1	-0.001	1.001	NC
327		2	-0.001	1.028	4004
328		3	-0.002	1.047	3499
329		4	-0.002	1.06	5595
330		5	-0.002	1.069	NC
331	5 M10	1	-0.001	1.024	NC
332		2	-0.001	1.047	3586
333		3	-0.001	1.06	3134
334		4	-0.001	1.066	5011
335		5	-0.001	1.069	NC
336	5 M11	1	-1.068	-0.031	NC
337		2	-1.068	-0.025	NC
338		3	-1.068	-0.018	NC
339		4	-1.069	-0.01	NC
340		5	-1.069	-0.001	NC
341	5 M12	1	-1.067	0.03	NC
342		2	-1.068	0.029	NC
343		3	-1.068	-0.003	NC
344		4	-1.068	-0.033	NC
345		5	-1.068	-0.031	NC
346	5 M13	1	-0.002	1.019	NC
347		2	-0.002	1.043	3656
348		3	-0.002	1.057	3196
349		4	-0.002	1.064	5109
350		5	-0.002	1.068	NC
351	5 M14	1	-1.068	-0.045	NC
352		2	-1.068	-0.034	NC
353		3	-1.068	-0.023	NC
354		4	-1.068	-0.012	NC
355		5	-1.068	-0.002	NC
356	5 M15	1	-0.723	-0.787	NC
357		2	-0.722	-0.772	NC
358		3	-0.721	-0.757	NC
359		4	-0.72	-0.74	NC
360		5	-0.719	-0.722	NC
361	5 M16	1	-0.722	0.719	NC
362		2	-0.725	0.733	NC
363		3	-0.728	0.748	NC
364		4	-0.731	0.762	NC
365		5	-0.733	0.776	NC
366	5 M17	1	-0.733	-0.777	NC
367		2	-0.731	-0.766	NC
368		3	-0.728	-0.753	NC
369		4	-0.726	-0.74	NC
370		5	-0.723	-0.725	NC
371	5 M18	1	-0.667	0.777	NC
372		2	-0.669	0.79	NC
373		3	-0.67	0.804	NC
374		4	-0.672	0.817	NC
375		5	-0.673	0.83	NC
376	5 M19	1	-0.721	-0.79	NC
377		2	-0.718	-0.771	NC
378		3	-0.714	-0.752	NC
379		4	-0.711	-0.73	NC
380		5	-0.707	-0.708	NC

City of Pullman  
 Development & Permitting Services  
 ISSUED PERMIT

Building Planning  
 Engineering Public Works  
 Fire Traffic

SEE SHEET SHEET 2 FOR ENGINEER OF RECORD SEAL FOR ENCLOSED PLANS.



**Member AISC 14th (360-10): ASD Steel Code Checks (By Combination)**

LC	Member	Shape	UC Max	Loc[ft]	Shear UC	Loc[ft]	Pnc/om [k]	Pnt/om [k]	Mn/om [k-ft]	Cb	Eqn	
1	1	M1	W18X76	0.011	0	0	15	471.646	667.665	105.289	1	H1-1b
2	1	M2	W18X76	0.012	0	0	15	471.646	667.665	105.289	1	H1-1b*
3	1	M3	W18X76	0.022	15	0.001	15	471.646	667.665	105.289	1	H1-1b
4	1	M4	W18X76	0.002	4.75	0.002	4.75	632.36	667.665	406.687	2.326	H1-1b
5	1	M5	W18X76	0.005	0	0.003	0	641.179	667.665	406.687	1.351	H1-1b
6	1	M6	W18X76	0.011	0	0.009	0	643.977	667.665	406.687	1.708	H1-1b
7	1	M7	W30x99withC...	0.026	20.318	0.009	0	179.822	1083.832	974.515	2.086	H1-1b
8	1	M8	W30x99withC...	0	2.25	0.001	0	948.751	1083.832	974.515	2.326	H1-1b*
9	1	M9	W18X76	0.021	0	0.002	3.5	641.179	667.665	105.289	1	H1-1b
10	1	M10	W18X76	0.008	0	0.001	3.5	641.179	667.665	105.289	1	H1-1b
11	1	M11	W18X76	0.01	3.5	0.003	3.5	641.179	667.665	406.687	1.125	H1-1b
12	1	M12	W18X76	0.008	22	0.006	22	316.13	667.665	406.687	1.425	H1-1b
13	1	M13	W18X76	0.009	0	0.001	3.5	641.179	667.665	105.289	1	H1-1b
14	1	M14	W18X76	0.005	3.5	0.003	3.5	641.179	667.665	406.687	1.336	H1-1b
15	1	M15	LL3.5x3.5x4x3	0.009	2.526	0.001	4.95	54.353	73.293	4.516	1	H1-1b
16	1	M16	LL3.5x3.5x4x3	0.016	0	0.001	4.95	54.353	73.293	4.516	1	H1-1b*
17	1	M17	LL3.5x3.5x4x3	0.022	4.95	0.001	4.95	54.353	73.293	4.516	1	H1-1b*
18	1	M18	LL3.5x3.5x4x3	0.032	0	0.001	4.61	54.487	73.293	4.516	1	H1-1b*
19	1	M19	LL3.5x3.5x4x3	0.02	4.95	0.001	4.95	54.353	73.293	4.516	1	H1-1b*
20	2	M1	W18X76	0.011	0	0	15	471.646	667.665	105.289	1	H1-1b
21	2	M2	W18X76	0.012	0	0	15	471.646	667.665	105.289	1	H1-1b*
22	2	M3	W18X76	0.022	15	0.001	15	471.646	667.665	105.289	1	H1-1b
23	2	M4	W18X76	0.002	4.75	0.002	4.75	632.36	667.665	406.687	2.326	H1-1b
24	2	M5	W18X76	0.005	0	0.003	0	641.179	667.665	406.687	1.351	H1-1b
25	2	M6	W18X76	0.011	0	0.009	0	643.977	667.665	406.687	1.708	H1-1b
26	2	M7	W30x99withC...	0.026	20.318	0.009	0	179.822	1083.832	974.515	2.086	H1-1b
27	2	M8	W30x99withC...	0	2.25	0.001	0	948.751	1083.832	974.515	2.326	H1-1b*
28	2	M9	W18X76	0.021	0	0.002	3.5	641.179	667.665	105.289	1	H1-1b
29	2	M10	W18X76	0.008	0	0.001	3.5	641.179	667.665	105.289	1	H1-1b
30	2	M11	W18X76	0.01	3.5	0.003	3.5	641.179	667.665	406.687	1.125	H1-1b
31	2	M12	W18X76	0.008	22	0.006	22	316.13	667.665	406.687	1.425	H1-1b
32	2	M13	W18X76	0.009	0	0.001	3.5	641.179	667.665	105.289	1	H1-1b
33	2	M14	W18X76	0.005	3.5	0.003	3.5	641.179	667.665	406.687	1.336	H1-1b
34	2	M15	LL3.5x3.5x4x3	0.009	2.526	0.001	4.95	54.353	73.293	4.516	1	H1-1b
35	2	M16	LL3.5x3.5x4x3	0.016	0	0.001	4.95	54.353	73.293	4.516	1	H1-1b*
36	2	M17	LL3.5x3.5x4x3	0.022	4.95	0.001	4.95	54.353	73.293	4.516	1	H1-1b*
37	2	M18	LL3.5x3.5x4x3	0.032	0	0.001	4.61	54.487	73.293	4.516	1	H1-1b*
38	2	M19	LL3.5x3.5x4x3	0.02	4.95	0.001	4.95	54.353	73.293	4.516	1	H1-1b*
39	4	M1	W18X76	0.431	0	0.022	0	471.646	667.665	105.289	1	H1-1b
40	4	M2	W18X76	0.447	0	0.022	0	471.646	667.665	105.289	1	H1-1b
41	4	M3	W18X76	0.455	0	0.023	0	471.646	667.665	105.289	1	H1-1b
42	4	M4	W18X76	0.002	4.75	0.002	4.75	632.36	667.665	406.687	2.327	H1-1b
43	4	M5	W18X76	0.098	3.5	0.046	0	641.179	667.665	406.687	1.352	H1-1b
44	4	M6	W18X76	0.042	0	0.037	0	643.977	667.665	406.687	1.676	H1-1b
45	4	M7	W30x99withC...	0.226	38.042	0.043	38.042	179.822	1083.832	180.069	1.579	H1-1b
46	4	M8	W30x99withC...	0	0	0.001	0	948.751	1083.832	726.631	2.326	H1-1b*
47	4	M9	W18X76	0.348	0	0.039	3.5	641.179	667.665	105.289	1	H1-1b
48	4	M10	W18X76	0.326	0	0.037	3.5	641.179	667.665	105.289	1	H1-1b
49	4	M11	W18X76	0.104	0	0.042	0	641.179	667.665	406.687	1.298	H1-1b
50	4	M12	W18X76	0.096	22	0.028	22	316.13	667.665	406.687	2.141	H1-1b
51	4	M13	W18X76	0.317	0	0.036	3.5	641.179	667.665	105.289	1	H1-1b
52	4	M14	W18X76	0.035	3.5	0.026	0	641.179	667.665	406.687	1.725	H1-1b
53	4	M15	LL3.5x3.5x4x3	0.116	4.95	0	4.95	54.353	73.293	4.516	1	H1-1b*
54	4	M16	LL3.5x3.5x4x3	0.183	4.95	0.002	4.95	54.353	73.293	4.516	1	H1-1b*
55	4	M17	LL3.5x3.5x4x3	0.281	4.95	0	4.95	54.353	73.293	4.516	1	H1-1b*
56	4	M18	LL3.5x3.5x4x3	0.075	4.61	0.002	4.61	54.487	73.293	4.516	1	H1-1b*

SEE SHEET SHEET 2 FOR ENGINEER OF RECORD SEAL FOR ENCLOSED PLANS.

City of Puyallup  
 Development & Permitting Services  
 ISSUED PERMIT # 11-10-27

Building Planning  
 Engineering Public Works  
 Fire Traffic



**Member AISC 14th (360-10): ASD Steel Code Checks (By Combination) (Continued)**

LC	Member	Shape	UC Max	Loc[ft]	Shear UC	Loc[ft]	Pnc/om [k]	Pnt/om [k]	Mn/om [k-ft]	Cb	Eqn	
57	4	M19	LL3.5x3.5x4x3	0.391	4.95	0	4.95	54.353	73.293	4.516	1	H1-1a*
58	5	M1	W18X76	0.454	0	0.022	0	471.646	667.665	105.289	1	H1-1b
59	5	M2	W18X76	0.455	0	0.023	0	471.646	667.665	105.289	1	H1-1b
60	5	M3	W18X76	0.432	0	0.021	0	471.646	667.665	105.289	1	H1-1b
61	5	M4	W18X76	0.002	4.75	0.002	4.75	632.36	667.665	406.687	2.326	H1-1b
62	5	M5	W18X76	0.102	3.5	0.043	3.5	641.179	667.665	406.687	1.305	H1-1b
63	5	M6	W18X76	0.024	0	0.02	3	643.977	667.665	406.687	1.649	H1-1b
64	5	M7	W30x99withC...	0.084	38.042	0.056	41.5	179.822	1083.832	974.515	2.1	H1-1b
65	5	M8	W30x99withC...	0	0	0.001	0	948.751	1083.832	726.631	2.327	H1-1b*
66	5	M9	W18X76	0.314	0	0.034	3.5	641.179	667.665	105.289	1	H1-1b
67	5	M10	W18X76	0.341	0	0.038	3.5	641.179	667.665	105.289	1	H1-1b
68	5	M11	W18X76	0.088	0	0.045	3.5	641.179	667.665	406.687	1.409	H1-1b
69	5	M12	W18X76	0.099	0	0.027	0	316.13	667.665	406.687	2.307	H1-1b
70	5	M13	W18X76	0.332	0	0.038	3.5	641.179	667.665	105.289	1	H1-1b
71	5	M14	W18X76	0.043	3.5	0.03	3.5	641.179	667.665	406.687	1.623	H1-1b
72	5	M15	LL3.5x3.5x4x3	0.075	4.95	0.002	4.95	54.353	73.293	4.516	1	H1-1b*
73	5	M16	LL3.5x3.5x4x3	0.279	0	0	4.95	54.353	73.293	4.516	1	H1-1a*
74	5	M17	LL3.5x3.5x4x3	0.176	4.95	0.002	4.95	54.353	73.293	4.516	1	H1-1b*
75	5	M18	LL3.5x3.5x4x3	0.164	0	0	4.61	54.487	73.293	4.516	1	H1-1b*
76	5	M19	LL3.5x3.5x4x3	0.27	2.475	0.002	4.95	54.353	73.293	4.516	1	H1-1a

**Member AISI S100-12: ASD Cold Formed Steel Code Checks**

LC	Member	Shape	UC Max	Loc[ft]	Shear UC	Loc[ft]	Pn/O...	Tn/O...	Mn/O...	Cb	Cm	Eqn
No Data to Print ...												

**Member Suggested Shapes**

Section Set/Member	Current Shape	Suggested Shape	Controlling Member	Controlling Criteria	Use Suggested?	
1	Col	W18X76	W10x45	M3	Strength	Yes
2	W18x Beam	W18X76	W14x53	M12	Strength	Yes
3	W30x Beam	W30x99withC15	W16x100	M7	Strength	Yes
4	L braces	LL3.5x3.5x4x3	LL3x2.5x4x3	M15	Strength	Yes

**Material Takeoff**

Material	Size	Pieces	Length[ft]	Weight[K]	
1	Hot Rolled Steel				
2	A36 Gr.36	LL3.5x3.5x4x3	5	24.4	0.282
3	A992	W18X76	12	95.8	7.266
4	A992	W30x99withC15	2	43.8	5.389
5	Total HR Steel		19	163.9	12.937

**Warning Log**

Message
No Data to Print ...

SEE SHEET SHEET 2 FOR ENGINEER OF RECORD SEAL FOR ENCLOSED PLANS.

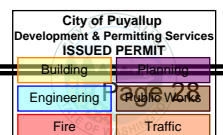



AHBL Engineers  
 2215 North 30th Street  
 Suite 300  
 Tacoma, WA 98403  
 253.383.2422

PRCTI20221709

Project Title: Red Dot Corporation Equipment Foundation  
 Engineer: ADM  
 Project ID: 2220760.20  
 Project Descr: New Equipment Foundations

**General Section Property Calculator**

Project File: 2220760.20.ec6

LIC# : KW-06014847, Build:20.22.8.17

AHBL, INC

(c) ENERCALC INC 1983-2022

**DESCRIPTION:** W18x76 Crane Rail Beam

**Final Section Properties**

Total Area :	32.017 in <sup>2</sup>	lxx :	1,841.40 in <sup>4</sup>	Sxx : - Y :	156.311 in <sup>3</sup>
Calculated final C.G. distance from Datum :		lyy :	464.356 in <sup>4</sup>	Sxx : +Y :	266.869 in <sup>3</sup>
X cg Dist. :	0.0 in	Zxx :	199.064 in <sup>3</sup>	Syy : - X :	61.856 in <sup>3</sup>
Y cg Dist. :	2.680 in	Zyy :	92.383 in <sup>3</sup>	Syy : +X :	61.856 in <sup>3</sup>
Edge Distances from CG. :				r xx :	7.584 in
+X :	7.507 in	+Y :	6.90 in	r yy :	3.808 in
-X :	-7.507 in	-Y :	-11.780 in		

Rotation of All Components @ / 0.00 deg CCW

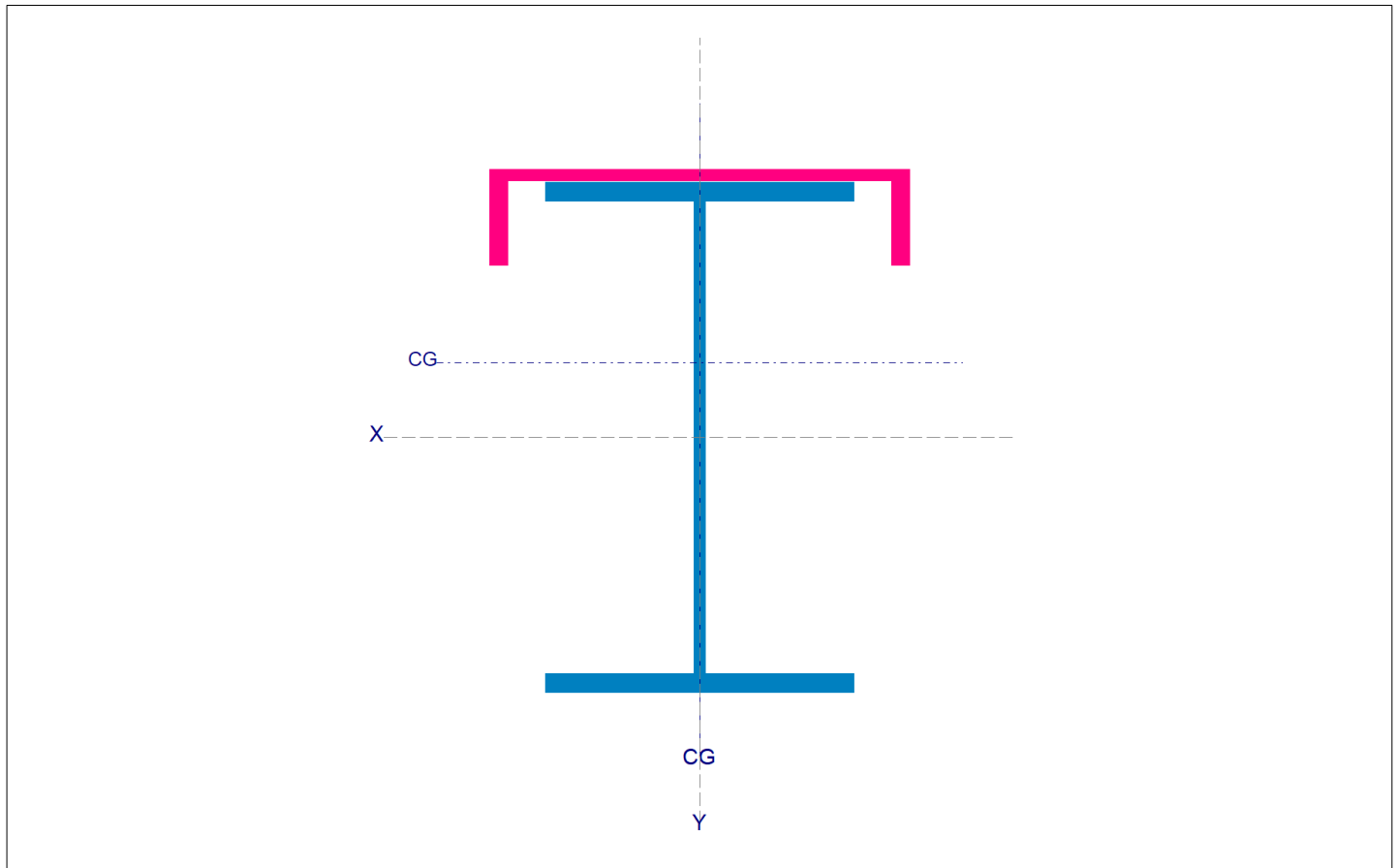

**Steel Shapes**

W18x76 : 1	Area =	22.117 in <sup>2</sup>	Rotation =	0 deg CCW
			Xcg =	0.000 in
			Ycg =	0.000 in
C15x33.9 : 2	Area =	9.900 in <sup>2</sup>	Rotation =	270 deg CCW
			Xcg =	0.000 in
			Ycg =	8.750 in

SEE SHEET SHEET 2 FOR ENGINEER OF RECORD SEAL FOR ENCLOSED PLANS.

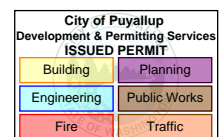



AHBL Engineers  
 2215 North 30th Street  
 Suite 300  
 Tacoma, WA 98403  
 253.383.2422

Project Title: Red Dot Corporation Equipment Foundation  
 Engineer: ADM  
 Project ID: 2220760.20  
 Project Descr: New Equipment Foundations

PRCTI20221709

**General Section Property Calculator**

Project File: 2220760.20.ec6

LIC# : KW-06014847, Build:20.22.8.17

AHBL, INC

(c) ENERCALC INC 1983-2022

**DESCRIPTION:** W30x99 Crane Rail Beam

**Final Section Properties**

Total Area :	38.717 in <sup>2</sup>	lxx :	5,537.70 in <sup>4</sup>	Sxx : - Y :	297.920 in <sup>3</sup>
Calculated final C.G. distance from Datum :		lyy :	443.002 in <sup>4</sup>	Sxx : +Y :	469.598 in <sup>3</sup>
X cg Dist. :	0.0 in	Zxx :	406.380 in <sup>3</sup>	Syy : - X :	59.011 in <sup>3</sup>
Y cg Dist. :	3.738 in	Zyy :	89.333 in <sup>3</sup>	Syy : +X :	59.011 in <sup>3</sup>
Edge Distances from CG. :				r xx :	11.959 in
+X :	7.507 in	+Y :	11.792 in	r yy :	3.383 in
-X :	-7.507 in	-Y :	-18.588 in		

Rotation of All Components @ / 0.00 deg CCW

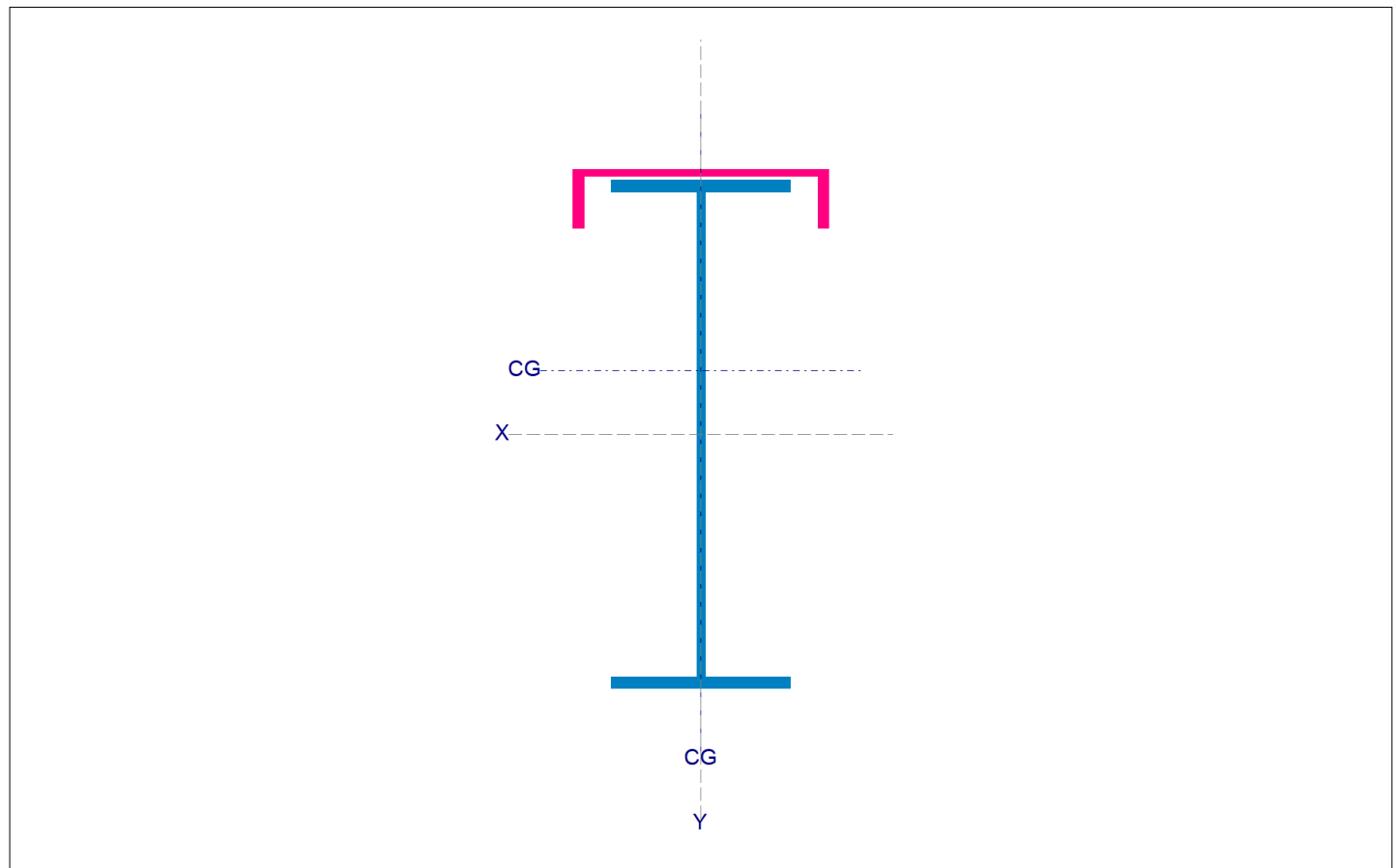

**Steel Shapes**

	W30x99 : 1	Area =	28.817 in <sup>2</sup>	Rotation =	0 deg CCW
				Xcg =	0.000 in
				Ycg =	0.000 in
	C15x33.9 : 2	Area =	9.900 in <sup>2</sup>	Rotation =	270 deg CCW
				Xcg =	0.000 in
				Ycg =	14.700 in

SEE SHEET SHEET 2 FOR ENGINEER OF RECORD SEAL FOR ENCLOSED PLANS.

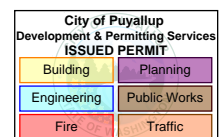



Project 2nd DOT BRIDGE CROSS  
Subject \_\_\_\_\_  
With/To \_\_\_\_\_  
Address \_\_\_\_\_  
Date 10/6/22

Project No. 2220760.25  
Phone \_\_\_\_\_  
Fax # \_\_\_\_\_  
# Faxed Pages \_\_\_\_\_  
By ADM

Page \_\_\_\_\_ of \_\_\_\_\_  
 Calculations  
 Fax  
 Memorandum  
 Meeting Minutes  
 Telephone Memo

Civil Engineers  
Structural Engineers  
Landscape Architects  
Community Planners  
Land Surveyors

### SEISMIC DESIGN

- CONTINUOUS COL SYSTEM IN TRANSVERSE DIRECTION
- STEEL COLS W/ KICKER BRACES IN LONGIT DIRECTION

$\therefore$  UFG  $R = 2.0 / \Omega_0 = 2.0$  FOR CONTINUOUS COLS

UFG  $R = 1.0 / \Omega_0 = 1.0$  FOR KICKERS

$C_s = S_{DS} / (R / I_e)$

$= 1.006 / R$

$= 1.006$  FOR KICKERS / LONGIT DIRECTION

$= 0.90$  FOR COLS / TRANS DIRECTION

### SEISMIC WEIGHT

$D_L = 6.6^k$  (BRIDGES) +  $1.5^k$  (TRAFFIC) +  
SELF WEIGHT

SEE SHEET SHEET 2 FOR ENGINEER OF RECORD SEAL FOR ENCLOSED PLANS.

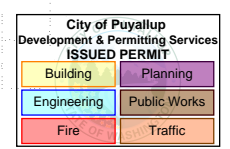



Project RSD DOT BRIDGE CRANE Project No. 2220760.20  Page \_\_\_\_ of \_\_\_\_  
 Subject \_\_\_\_\_ Phone \_\_\_\_\_  Calculations  
 With/To \_\_\_\_\_ Fax # \_\_\_\_\_  Fax  
 Address \_\_\_\_\_ # Faxed Pages \_\_\_\_\_  Memorandum  
 Date 10/26/22 By AM  Meeting Minutes  
 Telephone Memo

Civil Engineers

Structural Engineers

Landscape Architects

Community Planners

Land Surveyors

MAX SEISMIC FORCES AT COLS

LONGIT DIRECTION - SEE RISA 2D OUTPUT

$$M_{max} = 47.6 \text{ k-ft}$$

$$V_{max} = 6.1 \text{ k}$$

TRANSVERSE DIRECTION

$$W_{max} = \sqrt{2} [(6.6 \text{ k girders}) + (1.5 \text{ k truss})] + \text{SELF WT}$$

$$= 4.1 \text{ k} + 5.4 \text{ k}$$

$$= 9.5 \text{ k}$$

$$V_{max} = 0.5 (9.5 \text{ k})$$

$$= 4.75 \text{ k}$$

$$M_{max} = 80.75 \text{ k-ft}$$

∴ DOWEL NEW RTG INTO EXIST SLAB ON GRADE TO RESIST OVERTURNING

SEE SHEET SHEET 2 FOR ENGINEER OF RECORD SEAL FOR ENCLOSED PLANS.

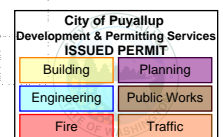





AHBL Engineers  
 2215 North 30th Street  
 Suite 300  
 Tacoma, WA 98403  
 253.383.2422

PRCTI20221709

Project Title: Red Dot Corporation Equipment Foundation  
 Engineer: ADM  
 Project ID: 2220760.20  
 Project Descr: New Equipment Foundations

**General Footing**

Project File: 2220760.20.ec6

LIC# : KW-06014847, Build:20.22.8.17

AHBL, INC

(c) ENERCALC INC 1983-2022

**DESCRIPTION:** Bridge Crane Spread Footing - Longit Direction

**Code References**

Calculations per ACI 318-14, IBC 2018, CBC 2019, ASCE 7-16  
 Load Combinations Used : IBC 2018

**General Information**

**Material Properties**

f <sub>c</sub> : Concrete 28 day strength	=	3.0 ksi
f <sub>y</sub> : Rebar Yield	=	60.0 ksi
E <sub>c</sub> : Concrete Elastic Modulus	=	3,122.0 ksi
Concrete Density	=	145.0 pcf
φ Values Flexure	=	0.90
Shear	=	0.750

**Soil Design Values**

Allowable Soil Bearing	=	2.50 ksf
Soil Density	=	110.0 pcf
Increase Bearing By Footing Weight	=	No
Soil Passive Resistance (for Sliding)	=	250.0 pcf
Soil/Concrete Friction Coeff.	=	0.30

**Analysis Settings**

Min Steel % Bending Reinf.	=	
Min Allow % Temp Reinf.	=	0.00180
Min. Overturning Safety Factor	=	1.0 : 1
Min. Sliding Safety Factor	=	1.0 : 1
Add Ftg Wt for Soil Pressure	:	Yes
Use ftg wt for stability, moments & shears	:	Yes
Add Pedestal Wt for Soil Pressure	:	No
Use Pedestal wt for stability, mom & shear	:	No

**Increases based on footing depth**

Footing base depth below soil surface	=	ft
Allow press. increase per foot of depth when footing base is below	=	ksf ft

**Increases based on footing plan dimension**

Allowable pressure increase per foot of depth when max. length or width is greater than	=	ksf ft
---	---	--------

**Dimensions**

Width parallel to X-X Axis	=	7.50 ft
Length parallel to Z-Z Axis	=	7.50 ft
Footing Thickness	=	24 in

**Pedestal dimensions...**

px : parallel to X-X Axis	=	in
pz : parallel to Z-Z Axis	=	in
Height	=	in
Rebar Centerline to Edge of Concrete... at Bottom of footing	=	3.0 in

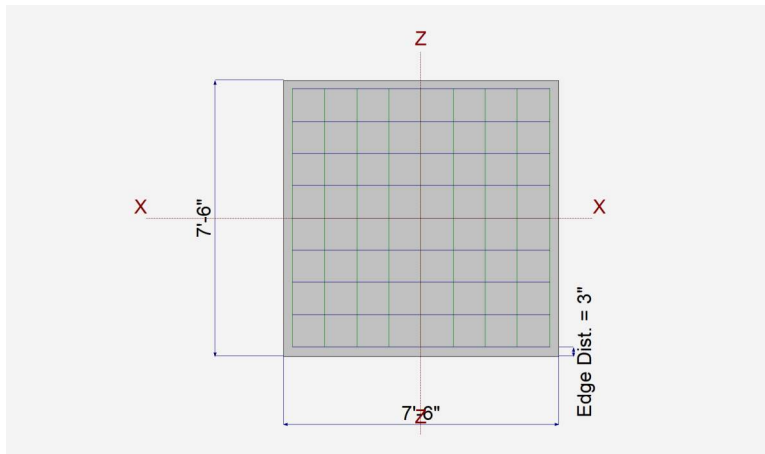

**Reinforcing**

Bars parallel to X-X Axis	=	
Number of Bars	=	9
Reinforcing Bar Size	=	# 6

Bars parallel to Z-Z Axis	=	
Number of Bars	=	9
Reinforcing Bar Size	=	# 6

**Bandwidth Distribution Check (ACI 15.4.4.2)**

Direction Requiring Closer Separation	=	n/a
# Bars required within zone	=	n/a
# Bars required on each side of zone	=	n/a

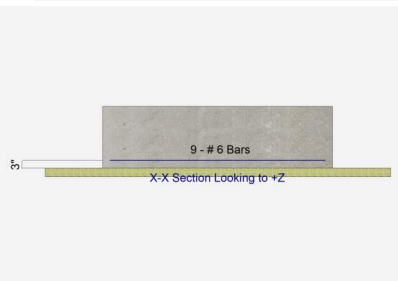

**Applied Loads**

	D	L <sub>r</sub>	L	S	W	E	H	
P : Column Load	=	10.0		20.0				k
OB : Overburden	=							ksf
M-xx	=							k-ft
M-zz	=					45.0		k-ft
V-x	=					6.10		k
V-z	=							k

SEE SHEET SHEET 2 FOR ENGINEER OF RECORD SEAL FOR ENCLOSED PLANS.

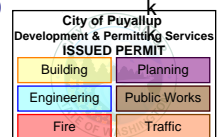



AHBL Engineers  
 2215 North 30th Street  
 Suite 300  
 Tacoma, WA 98403  
 253.383.2422

Project Title: Red Dot Corporation Equipment Foundation  
 Engineer: ADM  
 Project ID: 2220760.20  
 Project Descr: New Equipment Foundations

PRCTI20221709

**General Footing**

Project File: 2220760.20.ec6

LIC#: KW-06014847, Build:20.22.8.17

AHBL, INC

(c) ENERCALC INC 1983-2022

**DESCRIPTION:** Bridge Crane Spread Footing - Longit Direction

**DESIGN SUMMARY**

Design OK

Min. Ratio	Item	Applied	Capacity	Governing Load Combination	
PASS	0.4736	Soil Bearing	1.184 ksf	2.50 ksf	+0.60D+0.70E
PASS	n/a	Overturing - X-X	0.0 k-ft	0.0 k-ft	No Overturing
PASS	1.479	Overturing - Z-Z	40.040 k-ft	59.203 k-ft	+0.60D+0.70E
PASS	1.109	Sliding - X-X	4.270 k	4.736 k	+0.60D+0.70E
PASS	n/a	Sliding - Z-Z	0.0 k	0.0 k	No Sliding
PASS	n/a	Uplift	0.0 k	0.0 k	No Uplift
PASS	0.1878	Z Flexure (+X)	9.137 k-ft/ft	48.666 k-ft/ft	+1.20D+0.50L+E
PASS	0.1633	Z Flexure (-X)	7.947 k-ft/ft	48.666 k-ft/ft	+1.20D+1.60L
PASS	0.1633	X Flexure (+Z)	7.947 k-ft/ft	48.666 k-ft/ft	+1.20D+1.60L
PASS	0.1633	X Flexure (-Z)	7.947 k-ft/ft	48.666 k-ft/ft	+1.20D+1.60L
PASS	0.1324	1-way Shear (+X)	10.874 psi	82.158 psi	+1.20D+0.50L+E
PASS	0.1105	1-way Shear (-X)	9.082 psi	82.158 psi	+1.20D+1.60L
PASS	0.1105	1-way Shear (+Z)	9.082 psi	82.158 psi	+1.20D+1.60L
PASS	0.1105	1-way Shear (-Z)	9.082 psi	82.158 psi	+1.20D+1.60L
PASS	0.2067	2-way Punching	33.964 psi	164.317 psi	+1.20D+1.60L

**Detailed Results**

**Soil Bearing**

Rotation Axis & Load Combination...	Gross Allowable	Actual Soil Bearing Stress @ Location				Actual / Allow Ratio		
		Xecc	Zecc (in)	Bottom Left	Top Left		Top Right	Bottom Right
, D Only								0.000
, 0.0 deg CCW	2.50	0.0	0.0	0.4678	0.4678	0.4678	0.4678	0.187
, +D+L								0.000
, 0.0 deg CCW	2.50	0.0	0.0	0.8233	0.8233	0.8233	0.8233	0.329
, +D+0.750L								0.000
, 0.0 deg CCW	2.50	0.0	0.0	0.7344	0.7344	0.7344	0.7344	0.294
, +D+0.70E								0.000
, 0.0 deg CCW	2.50	18.261	0.0	0.0	0.0	1.064	1.064	0.426
, +D+0.750L+0.5250E								0.000
, 0.0 deg CCW	2.50	8.723	0.0	0.3116	0.3116	1.157	1.157	0.463
, +0.60D								0.000
, 0.0 deg CCW	2.50	0.0	0.0	0.2807	0.2807	0.2807	0.2807	0.112
, +0.60D+0.70E								0.000
, 0.0 deg CCW	2.50	30.434	0.0	0.0	0.0	1.184	1.184	0.474

**Overturing Stability**

Rotation Axis & Load Combination...	Overturing Moment	Resisting Moment	Stability Ratio	Status
X-X, D Only	None	0.0 k-ft	Infinity	OK
X-X, +D+L	None	0.0 k-ft	Infinity	OK
X-X, +D+0.750L	None	0.0 k-ft	Infinity	OK
X-X, +D+0.70E	None	0.0 k-ft	Infinity	OK
X-X, +D+0.750L+0.5250E	None	0.0 k-ft	Infinity	OK
X-X, +0.60D	None	0.0 k-ft	Infinity	OK
X-X, +0.60D+0.70E	None	0.0 k-ft	Infinity	OK
Z-Z, D Only	None	0.0 k-ft	Infinity	OK
Z-Z, +D+L	None	0.0 k-ft	Infinity	OK
Z-Z, +D+0.750L	None	0.0 k-ft	Infinity	OK
Z-Z, +D+0.70E	40.040 k-ft	98.672 k-ft	2.464	OK
Z-Z, +D+0.750L+0.5250E	30.030 k-ft	154.922 k-ft	5.159	OK
Z-Z, +0.60D	None	0.0 k-ft	Infinity	OK
Z-Z, +0.60D+0.70E	40.040 k-ft	59.203 k-ft	1.479	OK

All units k

**Sliding Stability**

Force Application Axis Load Combination...	Sliding Force	Resisting Force	Stability Ratio	Status
X-X, D Only	0.0 k	7.894 k	No Sliding	OK
X-X, +D+L	0.0 k	13.894 k	No Sliding	OK
X-X, +D+0.750L	0.0 k	12.394 k	No Sliding	OK

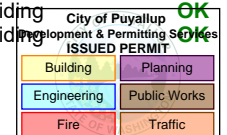

SEE SHEET SHEET 2 FOR ENGINEER OF RECORD SEAL FOR ENCLOSED PLANS.



AHBL Engineers  
 2215 North 30th Street  
 Suite 300  
 Tacoma, WA 98403  
 253.383.2422

PRCTI20221709

Project Title: Red Dot Corporation Equipment Foundation  
 Engineer: ADM  
 Project ID: 2220760.20  
 Project Descr: New Equipment Foundations

**General Footing**

Project File: 2220760.20.ec6

LIC#: KW-06014847, Build:20.22.8.17

AHBL, INC

(c) ENERCALC INC 1983-2022

**DESCRIPTION: Bridge Crane Spread Footing - Longit Direction**

All units k

**Sliding Stability**

Force Application Axis Load Combination...	Sliding Force	Resisting Force	Stability Ratio	Status
X-X, +D+0.70E	4.270 k	7.894 k	1.849	OK
X-X, +D+0.750L+0.5250E	3.203 k	12.394 k	3.870	OK
X-X, +0.60D	0.0 k	4.736 k	No Sliding	OK
X-X, +0.60D+0.70E	4.270 k	4.736 k	1.109	OK
Z-Z, D Only	0.0 k	7.894 k	No Sliding	OK
Z-Z, +D+L	0.0 k	13.894 k	No Sliding	OK
Z-Z, +D+0.750L	0.0 k	12.394 k	No Sliding	OK
Z-Z, +D+0.70E	0.0 k	7.894 k	No Sliding	OK
Z-Z, +D+0.750L+0.5250E	0.0 k	12.394 k	No Sliding	OK
Z-Z, +0.60D	0.0 k	4.736 k	No Sliding	OK
Z-Z, +0.60D+0.70E	0.0 k	4.736 k	No Sliding	OK

**Footing Flexure**

Flexure Axis & Load Combination	Mu k-ft	Side	Tension Surface	As Req'd in^2	Gvrn. As in^2	Actual As in^2	Phi*Mn k-ft	Status
X-X, +1.40D	4.605	+Z	Bottom	0.5184	AsMin	0.5280	48.666	OK
X-X, +1.40D	4.605	-Z	Bottom	0.5184	AsMin	0.5280	48.666	OK
X-X, +1.20D+1.60L	7.947	+Z	Bottom	0.5184	AsMin	0.5280	48.666	OK
X-X, +1.20D+1.60L	7.947	-Z	Bottom	0.5184	AsMin	0.5280	48.666	OK
X-X, +1.20D+0.50L	5.197	+Z	Bottom	0.5184	AsMin	0.5280	48.666	OK
X-X, +1.20D+0.50L	5.197	-Z	Bottom	0.5184	AsMin	0.5280	48.666	OK
X-X, +1.20D	3.947	+Z	Bottom	0.5184	AsMin	0.5280	48.666	OK
X-X, +1.20D	3.947	-Z	Bottom	0.5184	AsMin	0.5280	48.666	OK
X-X, +1.20D+0.50L+E	5.197	+Z	Bottom	0.5184	AsMin	0.5280	48.666	OK
X-X, +1.20D+0.50L+E	5.197	-Z	Bottom	0.5184	AsMin	0.5280	48.666	OK
X-X, +0.90D	2.960	+Z	Bottom	0.5184	AsMin	0.5280	48.666	OK
X-X, +0.90D	2.960	-Z	Bottom	0.5184	AsMin	0.5280	48.666	OK
X-X, +0.90D+E	2.960	+Z	Bottom	0.5184	AsMin	0.5280	48.666	OK
X-X, +0.90D+E	2.960	-Z	Bottom	0.5184	AsMin	0.5280	48.666	OK
Z-Z, +1.40D	4.605	-X	Bottom	0.5184	AsMin	0.5280	48.666	OK
Z-Z, +1.40D	4.605	+X	Bottom	0.5184	AsMin	0.5280	48.666	OK
Z-Z, +1.20D+1.60L	7.947	-X	Bottom	0.5184	AsMin	0.5280	48.666	OK
Z-Z, +1.20D+1.60L	7.947	+X	Bottom	0.5184	AsMin	0.5280	48.666	OK
Z-Z, +1.20D+0.50L	5.197	-X	Bottom	0.5184	AsMin	0.5280	48.666	OK
Z-Z, +1.20D+0.50L	5.197	+X	Bottom	0.5184	AsMin	0.5280	48.666	OK
Z-Z, +1.20D	3.947	-X	Bottom	0.5184	AsMin	0.5280	48.666	OK
Z-Z, +1.20D	3.947	+X	Bottom	0.5184	AsMin	0.5280	48.666	OK
Z-Z, +1.20D+0.50L+E	1.303	-X	Bottom	0.5184	AsMin	0.5280	48.666	OK
Z-Z, +1.20D+0.50L+E	9.137	+X	Bottom	0.5184	AsMin	0.5280	48.666	OK
Z-Z, +0.90D	2.960	-X	Bottom	0.5184	AsMin	0.5280	48.666	OK
Z-Z, +0.90D	2.960	+X	Bottom	0.5184	AsMin	0.5280	48.666	OK
Z-Z, +0.90D+E	0.000147	-X	Bottom	0.5184	AsMin	0.5280	48.666	OK
Z-Z, +0.90D+E	7.762	+X	Bottom	0.5184	AsMin	0.5280	48.666	OK

**One Way Shear**

Load Combination...	Vu @ -X	Vu @ +X	Vu @ -Z	Vu @ +Z	Vu:Max	Phi Vn	Vu / Phi*Vn	Status
+1.40D	5.26 psi	5.26 psi	5.26 psi	5.26 psi	5.26 psi	82.16 psi	0.06	OK
+1.20D+1.60L	9.08 psi	9.08 psi	9.08 psi	9.08 psi	9.08 psi	82.16 psi	0.11	OK
+1.20D+0.50L	5.94 psi	5.94 psi	5.94 psi	5.94 psi	5.94 psi	82.16 psi	0.07	OK
+1.20D	4.51 psi	4.51 psi	4.51 psi	4.51 psi	4.51 psi	82.16 psi	0.05	OK
+1.20D+0.50L+E	1.05 psi	10.87 psi	5.94 psi	5.94 psi	10.87 psi	82.16 psi	0.13	OK
+0.90D	3.38 psi	3.38 psi	3.38 psi	3.38 psi	3.38 psi	82.16 psi	0.04	OK
+0.90D+E	0.00 psi	9.68 psi	3.38 psi	3.38 psi	9.68 psi	82.16 psi	0.12	OK

**Two-Way "Punching" Shear**

All units k

Load Combination...	Vu	Phi*Vn	Vu / Phi*Vn	Status
+1.40D	19.68 psi	164.32psi	0.1198	OK
+1.20D+1.60L	33.96 psi	164.32psi	0.2067	OK
+1.20D+0.50L	22.21 psi	164.32psi	0.1352	OK
+1.20D	16.87 psi	164.32psi	0.1027	OK
+1.20D+0.50L+E	22.22 psi	164.32psi	0.1352	OK
+0.90D	12.65 psi	164.32psi	0.07699	OK

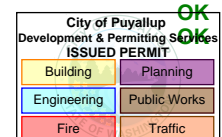

SEE SHEET SHEET 2 FOR ENGINEER OF RECORD SEAL FOR ENCLOSED PLANS.



AHBL Engineers  
 2215 North 30th Street  
 Suite 300  
 Tacoma, WA 98403  
 253.383.2422

PRCTI20221709

Project Title: Red Dot Corporation Equipment Foundation  
 Engineer: ADM  
 Project ID: 2220760.20  
 Project Descr: New Equipment Foundations

**General Footing**

Project File: 2220760.20.ec6

LIC# : KW-06014847, Build:20.22.8.17

AHBL, INC

(c) ENERCALC INC 1983-2022

**DESCRIPTION:** Bridge Crane Spread Footing - Longit Direction

**Two-Way "Punching" Shear**

All units k

Load Combination...	Vu	Phi*Vn	Vu / Phi*Vn	Status
+0.90D+E	13.20 psi	164.32psi	0.08033	OK

SEE SHEET SHEET 2 FOR ENGINEER OF RECORD SEAL FOR ENCLOSED PLANS.

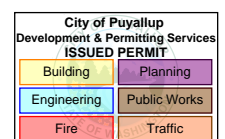



AHBL Engineers  
 2215 North 30th Street  
 Suite 300  
 Tacoma, WA 98403  
 253.383.2422

PRCTI20221709

Project Title: Red Dot Corporation Equipment Foundation  
 Engineer: ADM  
 Project ID: 2220760.20  
 Project Descr: New Equipment Foundations

**General Footing**

Project File: 2220760.20.ec6

LIC# : KW-06014847, Build:20.22.8.17

AHBL, INC

(c) ENERCALC INC 1983-2022

**DESCRIPTION:** Bridge Crane Spread Footing - Transverse Direction

**Code References**

Calculations per ACI 318-14, IBC 2018, CBC 2019, ASCE 7-16  
 Load Combinations Used : IBC 2018

**General Information**

**Material Properties**

f <sub>c</sub> : Concrete 28 day strength	=	3.0 ksi
f <sub>y</sub> : Rebar Yield	=	60.0 ksi
E <sub>c</sub> : Concrete Elastic Modulus	=	3,122.0 ksi
Concrete Density	=	145.0 pcf
φ Values Flexure	=	0.90
Shear	=	0.750

**Soil Design Values**

Allowable Soil Bearing	=	2.50 ksf
Soil Density	=	110.0 pcf
Increase Bearing By Footing Weight	=	No
Soil Passive Resistance (for Sliding)	=	250.0 pcf
Soil/Concrete Friction Coeff.	=	0.30

**Analysis Settings**

Min Steel % Bending Reinf.	=	
Min Allow % Temp Reinf.	=	0.00180
Min. Overturning Safety Factor	=	1.0 : 1
Min. Sliding Safety Factor	=	1.0 : 1
Add Ftg Wt for Soil Pressure	:	Yes
Use ftg wt for stability, moments & shears	:	Yes
Add Pedestal Wt for Soil Pressure	:	No
Use Pedestal wt for stability, mom & shear	:	No

**Increases based on footing depth**

Footing base depth below soil surface	=	2.0 ft
Allow press. increase per foot of depth when footing base is below	=	ksf ft

**Increases based on footing plan dimension**

Allowable pressure increase per foot of depth when max. length or width is greater than	=	ksf ft
---	---	--------

**Dimensions**

Width parallel to X-X Axis	=	9.250 ft
Length parallel to Z-Z Axis	=	9.250 ft
Footing Thickness	=	24.0 in

**Pedestal dimensions...**

px : parallel to X-X Axis	=	in
pz : parallel to Z-Z Axis	=	in
Height	=	in
Rebar Centerline to Edge of Concrete... at Bottom of footing	=	3.0 in

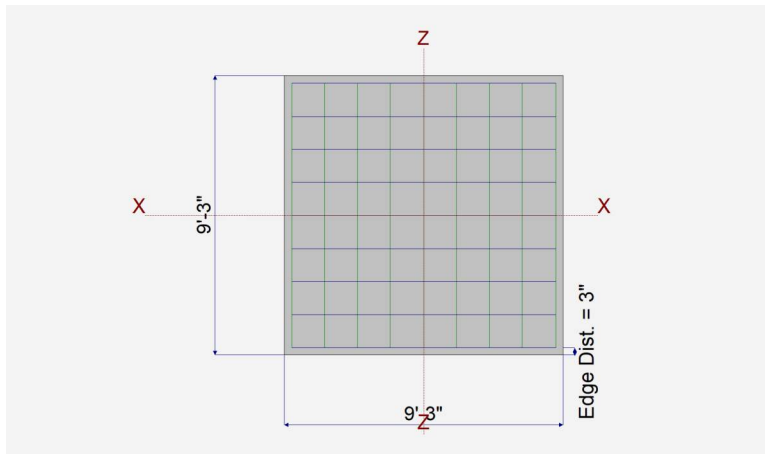

**Reinforcing**

Bars parallel to X-X Axis	=	
Number of Bars	=	9.0
Reinforcing Bar Size	=	# 7

Bars parallel to Z-Z Axis	=	
Number of Bars	=	9.0
Reinforcing Bar Size	=	# 7

**Bandwidth Distribution Check (ACI 15.4.4.2)**

Direction Requiring Closer Separation

# Bars required within zone	n/a
# Bars required on each side of zone	n/a

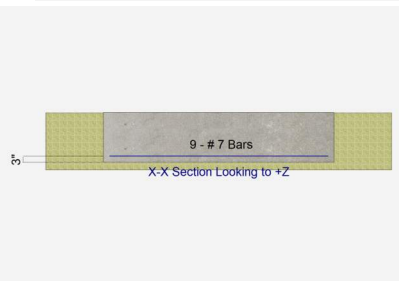

**Applied Loads**

	D	L <sub>r</sub>	L	S	W	E	H
P : Column Load	=	10.0		20.0			k
OB : Overburden	=						ksf
M-xx	=						k-ft
M-zz	=					90.0	k-ft
V-x	=					5.0	k
V-z	=						k

SEE SHEET SHEET 2 FOR ENGINEER OF RECORD SEAL FOR ENCLOSED PLANS.

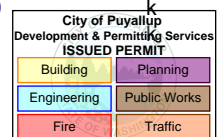



AHBL Engineers  
 2215 North 30th Street  
 Suite 300  
 Tacoma, WA 98403  
 253.383.2422

PRCTI20221709

Project Title: Red Dot Corporation Equipment Foundation  
 Engineer: ADM  
 Project ID: 2220760.20  
 Project Descr: New Equipment Foundations

**General Footing**

Project File: 2220760.20.ec6

LIC#: KW-06014847, Build:20.22.8.17

AHBL, INC

(c) ENERCALC INC 1983-2022

**DESCRIPTION:** Bridge Crane Spread Footing - Transverse Direction

**DESIGN SUMMARY**

Design OK

Min. Ratio	Item	Applied	Capacity	Governing Load Combination
PASS 0.4672	Soil Bearing	1.168 ksf	2.50 ksf	+0.60D+0.70E about Z-Z axis
PASS n/a	Overturning - X-X	0.0 k-ft	0.0 k-ft	No Overturning
PASS 1.380	Overturning - Z-Z	70.0 k-ft	96.606 k-ft	+0.60D+0.70E
PASS 3.112	Sliding - X-X	3.50 k	10.891 k	+0.60D+0.70E
PASS n/a	Sliding - Z-Z	0.0 k	0.0 k	No Sliding
PASS n/a	Uplift	0.0 k	0.0 k	No Uplift
PASS 0.1541	Z Flexure (+X)	8.268 k-ft/ft	53.664 k-ft/ft	+1.20D+0.50L+E
PASS 0.1025	Z Flexure (-X)	5.50 k-ft/ft	53.664 k-ft/ft	+1.20D+1.60L
PASS 0.1025	X Flexure (+Z)	5.50 k-ft/ft	53.664 k-ft/ft	+1.20D+1.60L
PASS 0.1025	X Flexure (-Z)	5.50 k-ft/ft	53.664 k-ft/ft	+1.20D+1.60L
PASS 0.1096	1-way Shear (+X)	9.007 psi	82.158 psi	+1.20D+0.50L+E
PASS 0.07122	1-way Shear (-X)	5.852 psi	82.158 psi	+1.20D+1.60L
PASS 0.07122	1-way Shear (+Z)	5.852 psi	82.158 psi	+1.20D+1.60L
PASS 0.07122	1-way Shear (-Z)	5.852 psi	82.158 psi	+1.20D+1.60L
PASS 0.1469	2-way Punching	24.135 psi	164.317 psi	+1.20D+1.60L

**Detailed Results**

**Soil Bearing**

Rotation Axis & Load Combination...	Gross Allowable	Xecc		Actual Soil Bearing Stress @ Location				Actual / Allow Ratio
		Zecc (in)		Bottom, -Z	Top, +Z	Left, -X	Right, +X	
X-X, D Only	2.50	n/a	0.0	0.4069	0.4069	n/a	n/a	0.163
X-X, +D+L	2.50	n/a	0.0	0.6406	0.6406	n/a	n/a	0.256
X-X, +D+0.750L	2.50	n/a	0.0	0.5822	0.5822	n/a	n/a	0.233
X-X, +D+0.70E	2.50	n/a	0.0	0.4069	0.4069	n/a	n/a	0.163
X-X, +D+0.750L+0.5250E	2.50	n/a	0.0	0.5822	0.5822	n/a	n/a	0.233
X-X, +0.60D	2.50	n/a	0.0	0.2441	0.2441	n/a	n/a	0.098
X-X, +0.60D+0.70E	2.50	n/a	0.0	0.2441	0.2441	n/a	n/a	0.098
Z-Z, D Only	2.50	0.0	n/a	n/a	n/a	0.4069	0.4069	0.163
Z-Z, +D+L	2.50	0.0	n/a	n/a	n/a	0.6406	0.6406	0.256
Z-Z, +D+0.750L	2.50	0.0	n/a	n/a	n/a	0.5822	0.5822	0.233
Z-Z, +D+0.70E	2.50	24.129	n/a	n/a	n/a	0.0	0.9541	0.382
Z-Z, +D+0.750L+0.5250E	2.50	12.647	n/a	n/a	n/a	0.1882	0.9762	0.391
Z-Z, +0.60D	2.50	0.0	n/a	n/a	n/a	0.2441	0.2441	0.098
Z-Z, +0.60D+0.70E	2.50	40.215	n/a	n/a	n/a	0.0	1.168	0.467

**Overturning Stability**

Rotation Axis & Load Combination...	Overturning Moment	Resisting Moment	Stability Ratio	Status
X-X, D Only	None	0.0 k-ft	Infinity	OK
X-X, +D+L	None	0.0 k-ft	Infinity	OK
X-X, +D+0.750L	None	0.0 k-ft	Infinity	OK
X-X, +D+0.70E	None	0.0 k-ft	Infinity	OK
X-X, +D+0.750L+0.5250E	None	0.0 k-ft	Infinity	OK
X-X, +0.60D	None	0.0 k-ft	Infinity	OK
X-X, +0.60D+0.70E	None	0.0 k-ft	Infinity	OK
Z-Z, D Only	None	0.0 k-ft	Infinity	OK
Z-Z, +D+L	None	0.0 k-ft	Infinity	OK
Z-Z, +D+0.750L	None	0.0 k-ft	Infinity	OK
Z-Z, +D+0.70E	70.0 k-ft	161.011 k-ft	2.30	OK
Z-Z, +D+0.750L+0.5250E	52.50 k-ft	230.386 k-ft	4.388	OK
Z-Z, +0.60D	None	0.0 k-ft	Infinity	OK
Z-Z, +0.60D+0.70E	70.0 k-ft	96.606 k-ft	1.380	OK

All units k

**Sliding Stability**

Force Application Axis Load Combination...	Sliding Force	Resisting Force	Stability Ratio	Status
X-X, D Only	0.0 k	15.069 k	No Sliding	OK
X-X, +D+L	0.0 k	21.069 k	No Sliding	OK
X-X, +D+0.750L	0.0 k	19.569 k	No Sliding	OK

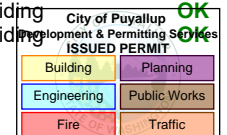

SEE SHEET SHEET 2 FOR ENGINEER OF RECORD SEAL FOR ENCLOSED PLANS.



AHBL Engineers  
 2215 North 30th Street  
 Suite 300  
 Tacoma, WA 98403  
 253.383.2422

PRCTI20221709

Project Title: Red Dot Corporation Equipment Foundation  
 Engineer: ADM  
 Project ID: 2220760.20  
 Project Descr: New Equipment Foundations

**General Footing**

Project File: 2220760.20.ec6

LIC# : KW-06014847, Build:20.22.8.17

AHBL, INC

(c) ENERCALC INC 1983-2022

**DESCRIPTION: Bridge Crane Spread Footing - Transverse Direction**

All units k

**Sliding Stability**

Force Application Axis Load Combination...	Sliding Force	Resisting Force	Stability Ratio	Status
X-X, +D+0.70E	3.50 k	15.069 k	4.305	OK
X-X, +D+0.750L+0.5250E	2.625 k	19.569 k	7.455	OK
X-X, +0.60D	0.0 k	10.891 k	No Sliding	OK
X-X, +0.60D+0.70E	3.50 k	10.891 k	3.112	OK
Z-Z, D Only	0.0 k	15.069 k	No Sliding	OK
Z-Z, +D+L	0.0 k	21.069 k	No Sliding	OK
Z-Z, +D+0.750L	0.0 k	19.569 k	No Sliding	OK
Z-Z, +D+0.70E	0.0 k	15.069 k	No Sliding	OK
Z-Z, +D+0.750L+0.5250E	0.0 k	19.569 k	No Sliding	OK
Z-Z, +0.60D	0.0 k	10.891 k	No Sliding	OK
Z-Z, +0.60D+0.70E	0.0 k	10.891 k	No Sliding	OK

**Footing Flexure**

Flexure Axis & Load Combination	Mu k-ft	Side	Tension Surface	As Req'd in^2	Gvrn. As in^2	Actual As in^2	Phi*Mn k-ft	Status
X-X, +1.40D	1.750	+Z	Bottom	0.5184	AsMin	0.5838	53.664	OK
X-X, +1.40D	1.750	-Z	Bottom	0.5184	AsMin	0.5838	53.664	OK
X-X, +1.20D+1.60L	5.50	+Z	Bottom	0.5184	AsMin	0.5838	53.664	OK
X-X, +1.20D+1.60L	5.50	-Z	Bottom	0.5184	AsMin	0.5838	53.664	OK
X-X, +1.20D+0.50L	2.750	+Z	Bottom	0.5184	AsMin	0.5838	53.664	OK
X-X, +1.20D+0.50L	2.750	-Z	Bottom	0.5184	AsMin	0.5838	53.664	OK
X-X, +1.20D	1.50	+Z	Bottom	0.5184	AsMin	0.5838	53.664	OK
X-X, +1.20D	1.50	-Z	Bottom	0.5184	AsMin	0.5838	53.664	OK
X-X, +1.20D+0.50L+E	2.750	+Z	Bottom	0.5184	AsMin	0.5838	53.664	OK
X-X, +1.20D+0.50L+E	2.750	-Z	Bottom	0.5184	AsMin	0.5838	53.664	OK
X-X, +0.90D	1.125	+Z	Bottom	0.5184	AsMin	0.5838	53.664	OK
X-X, +0.90D	1.125	-Z	Bottom	0.5184	AsMin	0.5838	53.664	OK
X-X, +0.90D+E	1.125	+Z	Bottom	0.5184	AsMin	0.5838	53.664	OK
X-X, +0.90D+E	1.125	-Z	Bottom	0.5184	AsMin	0.5838	53.664	OK
Z-Z, +1.40D	1.750	-X	Bottom	0.5184	AsMin	0.5838	53.664	OK
Z-Z, +1.40D	1.750	+X	Bottom	0.5184	AsMin	0.5838	53.664	OK
Z-Z, +1.20D+1.60L	5.50	-X	Bottom	0.5184	AsMin	0.5838	53.664	OK
Z-Z, +1.20D+1.60L	5.50	+X	Bottom	0.5184	AsMin	0.5838	53.664	OK
Z-Z, +1.20D+0.50L	2.750	-X	Bottom	0.5184	AsMin	0.5838	53.664	OK
Z-Z, +1.20D+0.50L	2.750	+X	Bottom	0.5184	AsMin	0.5838	53.664	OK
Z-Z, +1.20D	1.50	-X	Bottom	0.5184	AsMin	0.5838	53.664	OK
Z-Z, +1.20D	1.50	+X	Bottom	0.5184	AsMin	0.5838	53.664	OK
Z-Z, +1.20D+0.50L+E	2.543	-X	Top	0.5184	AsMin	0.5838	53.664	OK
Z-Z, +1.20D+0.50L+E	8.268	+X	Bottom	0.5184	AsMin	0.5838	53.664	OK
Z-Z, +0.90D	1.125	-X	Bottom	0.5184	AsMin	0.5838	53.664	OK
Z-Z, +0.90D	1.125	+X	Bottom	0.5184	AsMin	0.5838	53.664	OK
Z-Z, +0.90D+E	2.791	-X	Top	0.5184	AsMin	0.5838	53.664	OK
Z-Z, +0.90D+E	8.018	+X	Bottom	0.5184	AsMin	0.5838	53.664	OK

**One Way Shear**

Load Combination...	Vu @ -X	Vu @ +X	Vu @ -Z	Vu @ +Z	Vu:Max	Phi Vn	Vu / Phi*Vn	Status
+1.40D	1.86 psi	1.86 psi	1.86 psi	1.86 psi	1.86 psi	82.16 psi	0.02	OK
+1.20D+1.60L	5.85 psi	5.85 psi	5.85 psi	5.85 psi	5.85 psi	82.16 psi	0.07	OK
+1.20D+0.50L	2.93 psi	2.93 psi	2.93 psi	2.93 psi	2.93 psi	82.16 psi	0.04	OK
+1.20D	1.60 psi	1.60 psi	1.60 psi	1.60 psi	1.60 psi	82.16 psi	0.02	OK
+1.20D+0.50L+E	2.98 psi	9.01 psi	2.93 psi	2.93 psi	9.01 psi	82.16 psi	0.11	OK
+0.90D	1.20 psi	1.20 psi	1.20 psi	1.20 psi	1.20 psi	82.16 psi	0.01	OK
+0.90D+E	2.97 psi	8.98 psi	1.20 psi	1.20 psi	8.98 psi	82.16 psi	0.11	OK

All units k

**Two-Way "Punching" Shear**

Load Combination...	Vu	Phi*Vn	Vu / Phi*Vn	Status
+1.40D	7.68 psi	164.32psi	0.04674	OK
+1.20D+1.60L	24.14 psi	164.32psi	0.1469	OK
+1.20D+0.50L	12.07 psi	164.32psi	0.07344	OK
+1.20D	6.58 psi	164.32psi	0.04006	OK
+1.20D+0.50L+E	12.09 psi	164.32psi	0.07356	OK
+0.90D	4.94 psi	164.32psi	0.03004	OK

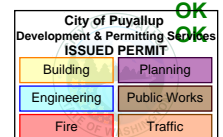

SEE SHEET SHEET 2 FOR ENGINEER OF RECORD SEAL FOR ENCLOSED PLANS.



AHBL Engineers  
 2215 North 30th Street  
 Suite 300  
 Tacoma, WA 98403  
 253.383.2422

Project ID: **PROJ20221709**  
 Engineer: ADM  
 Project ID: 2220760.20  
 Project Descr: New Equipment Foundations

**General Footing**

Project File: 2220760.20.ec6

LIC# : KW-06014847, Build:20.22.8.17

AHBL, INC

(c) ENERCALC INC 1983-2022

**DESCRIPTION:** Bridge Crane Spread Footing - Transverse Direction

**Two-Way "Punching" Shear**

All units k

Load Combination...	Vu	Phi*Vn	Vu / Phi*Vn	Status
+0.90D+E	5.47 psi	164.32psi	0.03327	<b>OK</b>

SEE SHEET SHEET 2 FOR ENGINEER OF RECORD SEAL FOR ENCLOSED PLANS.

