

CENTRAL PIERCE FIRE AND RESCUE BUILDING

1015 39TH AVE SE SUITE 120 PUYALLUP, WA 98374

FIRE ALARM SYSTEM



21312 30TH DRIVE SE
BOTHELL, WA 98021
P: 425-486-2600 F: 425-486-2611
WA LIC# ADTCCOCL801UQ



1015 39TH AVE SE
PUYALLUP, WA 98374
FIRE ALARM SYSTEM

SYMBOL	QTY	DESCRIPTION	MOUNTING REQUIREMENTS	SUPPLIER	PART NUMBER
	75	INTELLIGENT PHOTO SMOKE DETECTOR	4 SQUARE DEEP w/ 3" ROUND RING	NOTIFIER	FSP-951 w/ B300-6
	1	INTELLIGENT OUTPUT CONTROL MODULE	4 SQUARE DEEP	NOTIFIER	FCM-1
	1	120VAC VOLTAGE PROTECTOR FOR CONTROL PANELS w/ LOCKOUT & LABELS	MOUNTS IN 1/2" OR 3/4" CABINET KNOCKOUT	SPACEAGE	E120V-GT
	1	10.0 AMPS, 120VAC REMOTE CHARGER POWER SUPPLY IN LOCKABLE, METAL ENCLOSURE, BLACK	PART INCLUDE BACKBOX; SURFACE MOUNT	NOTIFIER	PSE-10
	27	CEILING HORN w/ STROBE: WHITE SEE DEVICE DESIGNATION FOR STROBE cd SETTING	4 SQUARE DEEP w/ EXT RING; CENTER ON CEILING TILE	SYSTEM SENSOR	PC2WL
	12	CEILING STROBE: WHITE SEE DEVICE DESIGNATION FOR STROBE cd SETTING	4 SQUARE DEEP; CENTER ON CEILING TILE	SYSTEM SENSOR	SCWL

NOTES:
 1- DEVICE SUBSCRIPT: NW-NEW RR-REMOVE & RELOCATE EX-EXISTING TO REMAIN AC-ABOVE CEILING RB-RELAY BASE WP-WATERPROOF WG-WIRE GUARD
 2- CABLING SHOWN IS FOR CIRCUIT REFERENCE ONLY AND DOES NOT INTENDED TO INDICATE THE EXACT PATHWAY.
 3- DEVICES SHOWN ON DRAWINGS IN GRAY SCALE ARE EXISTING DEVICES AND MAY NOT BE INCLUDED IN THIS SYMBOL LEGEND UNLESS NOTED.
 4- SET HORN/STROBE DECIBEL SETTINGS TO LOW FROM FACTORY SETTING OF HIGH, UNLESS OTHERWISE NOTED ON THE DRAWINGS.
 5- ALL DEVICES WITH A WP SUBSCRIPT WILL REQUIRE THE USE OF AN OUTDOOR OR WP BACKBOX.

SCOPE OF WORK & DESIGN BASIS

DESIGN CRITERIA APPLIED CODES AND STANDARDS:
 NFPA 72 2019 EDITION
 IBC 2018 EDITION WITH WASHINGTON AMENDMENTS
 NFPA 70 (NEC) 2017 EDITION

DOCUMENTS RECEIVED BY ADT:
 SHEETS:
 DATE:

INSTALLATION & GENERAL WIRING NOTES:

GENERAL NOTES:

- INSTALLATION SHALL BE ACCOMPLISHED IN STRICT COMPLIANCE WITH NFPA, LOCAL AND STATE AHJ's, NEC AND CONTRACT DRAWINGS
- WIRE ROUTING IS DIAGRAMMATIC IN NATURE ONLY AND NOT INTENDED FOR ACTUAL CONDUIT ROUTING.
- ALL CONDUIT SIZING AND ROUTING BY ELECTRICAL CONTRACTOR PER NEC AND AHJ.
- VERIFY ALL LOCATIONS OF DEVICES WITH ELECTRICAL/ARCHITECTURAL PLANS. SCALE AND PLACE ALL DEVICES PER ELECTRICAL/ARCHITECTURAL PLANS.
- ALL CIRCUITS WILL BE PROPERLY TAGGED AND TESTED FOR OPENS, SHORTS, GROUNDS AND PROPER "END-OF-LINE" RESISTANCE. EACH CIRCUITS METER READING MUST BE DOCUMENTED AND PRESENTED TO ADT COMMERCIAL (RHF&S) FIELD TECHNICIAN UPON ARRIVAL ONSITE FOR STARTUP & CHECKOUT.
- AS-BUILTS:
- 6.1. A SET OF INSTALLATION AS-BUILT DRAWINGS SHOWING ACTUAL CONDUIT AND CONDUCTOR ROUTES SHALL BE KEPT BY PROJECT FOREMAN FOR USE BY ADT COMMERCIAL (RHF&S) TECHNICIAN.
- 6.2. AS-BUILTS SHALL BE KEPT ORDERLY AND BE CLEARLY MARKED WITH DIFFERENT COLOR PENS FOR EACH CIRCUIT AND/OR CIRCUIT TYPE. AS-BUILTS MUST INDICATE CHANGES TO THE FINAL DEVICE INSTALLED LOCATIONS IF NOT INSTALLED AT LOCATION SHOWN ON DESIGN DOCUMENTS. AS-BUILT REDLINES NOT PROVIDING THIS INFORMATION WILL BE RETURNED TO THE INSTALLATION CONTRACTOR FOR CORRECTION. ADT COMMERCIAL (RHF&S) IS NOT RESPONSIBLE FOR THESE DELAYS.
- 6.3. AGREEMENT AND CONFIRMATION OF ALL MILESTONE EVENTS WILL BE MADE WITH ADT COMMERCIAL (RHF&S) PROJECT MANAGER.
8. ALL ADT COMMERCIAL (RHF&S) FIELD SERVICES MUST BE SCHEDULED WITH ADT COMMERCIAL (RHF&S) PROJECT MANAGER WITH A MINIMUM OF 14 WORKING DAYS ADVANCE NOTICE.
9. DO NOT INSTALL LINE VOLTAGE IN SAME CONDUIT AS POWER LIMITED CABLES.

PROJECT CONTACT INFORMATION:

CUSTOMER:
 NAME: EVERGREEN POWER SYSTEM INC
 ADDRESS: 3823 E MARGINAL WAY S
 SEATTLE WA 98134
 CONTACT: MICHAEL MILLS
 PHONE: 206-423-2421
 FAX:
 EMAIL: mmills@evergreens.net

FIRE ALARM / LIFE SAFETY PROVIDER:
 NAME: ADT COMMERCIAL (SEATTLE)
 ADDRESS: 21312 30TH DRIVE SE, SUITE #103
 BOTHELL, WA 98021
 PHONE: 425-486-2600
 FAX: 425-486-2611
 PROJECT MANAGER: DOUG MORGAN dougmorgan@adt.com EXT:
 DESIGNER: DIANA CLARK dianaclark@adt.com EXT:

REVISIONS

NO.	DATE	REVISION
△	01-25-2023 BY: DC	FOR PERMIT
△	BY: __	-
△	BY: __	-
△	BY: __	-
△	BY: __	-
△	BY: __	-
△	BY: __	-
△	BY: __	-
△	BY: __	-

CIRCUIT WIRING LEGEND
 see NFPA 72-13 12.7

- SLC1 | SLC1 | SLC (SIGNALING LINE CIRCUIT) WIRE #18/2 AWG - FPLP POWER LIMITED CLASS 'A1'
- NAC1 | NAC1 | NAC (NOTIFICATION ANNUNCIATION CIRCUIT) STROBE WIRE #14/2 AWG - FPLP POWER LIMITED CLASS 'B1'
- SBUS | SBUS | SBUS (SBUS COMMUNICATIONS) WIRE #18/4 AWG - FPLP POWER LIMITED CLASS 'B1'
- PWR | PWR | POWER WIRE WIRE #16/2 AWG - FPLP POWER LIMITED CLASS 'B1'
- SPK | SPK | SPEAKER POWER WIRE WIRE #16/2 AWG - FPLP POWER LIMITED CLASS 'B1'
- TRP | TRP | TRIP WIRE WIRE #18/2 AWG - FPLP POWER LIMITED CLASS 'D1'

ABBREVIATIONS

AC - ABOVE CEILING	FSD - FIRE SMOKE DAMPER (THIRD PARTY)
AFF - ABOVE FINISHED FLOOR	HVAC - HEATING, VENTILATION, AND AIR CONDITIONING (THIRD PARTY)
ADA - AMERICAN DISABILITIES ACT	LA - LOW AIR (THIRD PARTY)
AHJ - AUTHORITY HAVING JURISDICTION	N/A - NOT APPLICABLE
AHU - AIR HANDLING UNIT (THIRD PARTY)	NAC - NOTIFICATION APPLIANCE CIRCUIT
ASD - ASPIRATION SMOKE DETECTION	NFPA - NATIONAL FIRE PROTECTION ASSOCIATION
CD - CANDELA (EX 15CD)	NIC - NOT IN CONTRACT
CIS - COMMON INTELLIGIBILITY SCALE	NTS - NOT TO SCALE
DH - DOOR HOLDER (THIRD PARTY)	PS - POWER SUPPLY
EF - EXHAUST FAN (THIRD PARTY)	RTU - ROOF TOP UNIT (THIRD PARTY)
ELEV - ELEVATOR (THIRD PARTY)	SLC - SIGNALING LINE CIRCUIT
EDL - END OF LINE	SPF - STAIR PRESSURIZATION FAN (THIRD PARTY)
EPF - ELEVATOR PRESSURIZATION FAN (THIRD PARTY)	STI - SPEECH TRANSMISSION INDEX
FA - FIRE ALARM	TYP - TYPICAL
FAA - FIRE ALARM ANNUNCIATOR	UNO - UNLESS NOTED OTHERWISE
FACP - FIRE ALARM CONTROL PANEL	VAV - VARIABLE AIR VOLUME (THIRD PARTY)
FACU - FIRE ALARM CONTROL UNIT	VFD - VARIABLE FREQUENCY DRIVE (THIRD PARTY)
FATC - FIRE ALARM TERMINAL CABINET	W - WITH
FBO - FURNISHED BY OTHERS	WI - WATT (EX 12W)
FCU - FAN COIL UNIT (THIRD PARTY)	WP - WEATHERPROOF
FFT - FIREFIGHTER'S TELEPHONE	XP - EXPLOSION PROOF
FM - FACTORY MUTUAL	

FLOOR PLAN KEY

DEVICE ADDRESS KEY
 ○ D-XXXX
 D = DETECTOR
 M = MODULE

DETAIL BUBBLE KEY
 ○ X
 X = DETAIL NUMBER
 ○ - DETAIL LOCATION (- = SAME SHEET)

NOTIFICATION DEVICE CIRCUIT KEY
 ○ SPK-XX
 ○ NXX-XX
 ○ FA-XX-XX
 ○ XX-XX-XX
 ○ XXXX
 ○ LOGICAL DEVICE NUMBER

DRAWING SHEET INDEX KEY
 ○ FIRE ALARM
 ○ FA-XX-XX
 ○ PAGE/FLOOR/AREA

○ = COVER SHEET
 1 = FLOOR PLANS
 2 = RISER DIAGRAMS
 3 = FIRE PANEL DETAILS
 4 = DEVICE DETAILS
 5 = CALCULATIONS
 6 = 2-WAY COMMUNICATION

FIRE ALARM SPECIFIC NOTES:

- SMOKE DETECTORS SHALL NOT BE INSTALLED WITHIN 36" OF ANY AIR DIFFUSER
- 2016 NFPA 72-17.7.1.11 REQUIRES THAT SMOKE DETECTORS SHALL NOT BE INSTALLED UNTIL AFTER FINAL CONSTRUCTION CLEAN-UP.
- 2.1. ANY SMOKE DETECTORS THAT HAVE BEEN INSTALLED PRIOR TO CLEAN-UP MUST BE CLEANED OR REPLACED AND WILL BE INVOICED ON A T&M BASIS.
- 2.2. WALL MOUNTED NOTIFICATION DEVICES BACKBOX BETWEEN A MINIMUM OF 80" AFF TO A MAXIMUM OF 96" AFF.
- 3.1. DEVICES THAT ARE UNABLE TO BE MOUNTED WITHIN THAT RANGE MUST BE VERIFIED BY ADT COMMERCIAL (RHF&S) PRIOR TO INSTALLATION.
- 3.2. SEE FLOOR PLANS FOR CANDELA RATING OF EACH DEVICE INSTALLED.
4. ALL MANUAL PULL STATIONS ARE TO BE MOUNTED AT A HEIGHT NO GREATER THAN 48" TO TOP AND NO LOWER THAN 36" TO BOTTOM (PER ADA REQUIREMENTS).
5. FIELD VERIFY ALL SPRINKLER MONITORING DEVICES WITH FIRE PROTECTION CONTRACTOR
6. FIELD VERIFY ALL HVAC, FAN CONTROL, FIRE/SMOKE DAMPERS AND DUCT DETECTORS LOCATIONS WITH MECHANICAL CONTRACTOR
7. FACP SHALL NOT BE ENERGIZED WITHOUT THE PRESENCE OF ADT COMMERCIAL (RHF&S) TECHNICIANS.
8. NO TAPPING OF SIGNALING OR INITIATING ZONE CIRCUITS ARE ALLOWED. T-TAPPING OF STYLE 4 ADDRESSABLE CIRCUITS IS ALLOWED PROVIDING A SPLICE IS PROFESSIONALLY INSTALLED. POLARITY IS OBSERVED AND SHIELDS ARE CONTINUOUS AND FREE OF GROUNDS. SHIELDS MUST BE TERMINATED AT FACP ONLY.
- 8.1. CABLE SHIELDS SHALL BE SPLICED TOGETHER AT EVERY JUNCTION BETWEEN THE FACP AND THE LAST DEVICE ON EACH CABLE RUN. SHIELDS AND OTHER FIRE ALARM CONDUCTORS (EXCEPT POWER GROUNDS) SHALL BE INSULATED AND COMPLETELY FREE FROM CONDUIT OR EARTH GROUNDS. SHIELDS WILL BE TIES TO GROUND ONLY AT THE FACP BY THE ADT COMMERCIAL (RHF&S) FIELD TECHNICIAN.
9. THE SYSTEM SHALL BE MONITORED BY A U.L. LISTED MONITORING STATION BEFORE AHJ TEST.
10. AS-BUILTS ARE REQUIRED AT TIME OF AHJ ACCEPTANCE. ADT COMMERCIAL (RHF&S) REQUIRED ELECTRICAL RED LINES WITHIN 2 WEEKS PRIOR TO AHJ TESTS.
- 10.1. EACH CIRCUIT (SLC, NAC OR POWER) MUST BE CLEARLY IDENTIFIED WITH A DISTINCT COLOR
- 10.2. EACH NAC CIRCUIT MUST BE CLEARLY MARKED AS TO WHICH DEVICES ARE ON EACH CIRCUIT AND IN THE ORDER THE DEVICES ARE WIRED TO COMPLETE THE CIRCUIT.

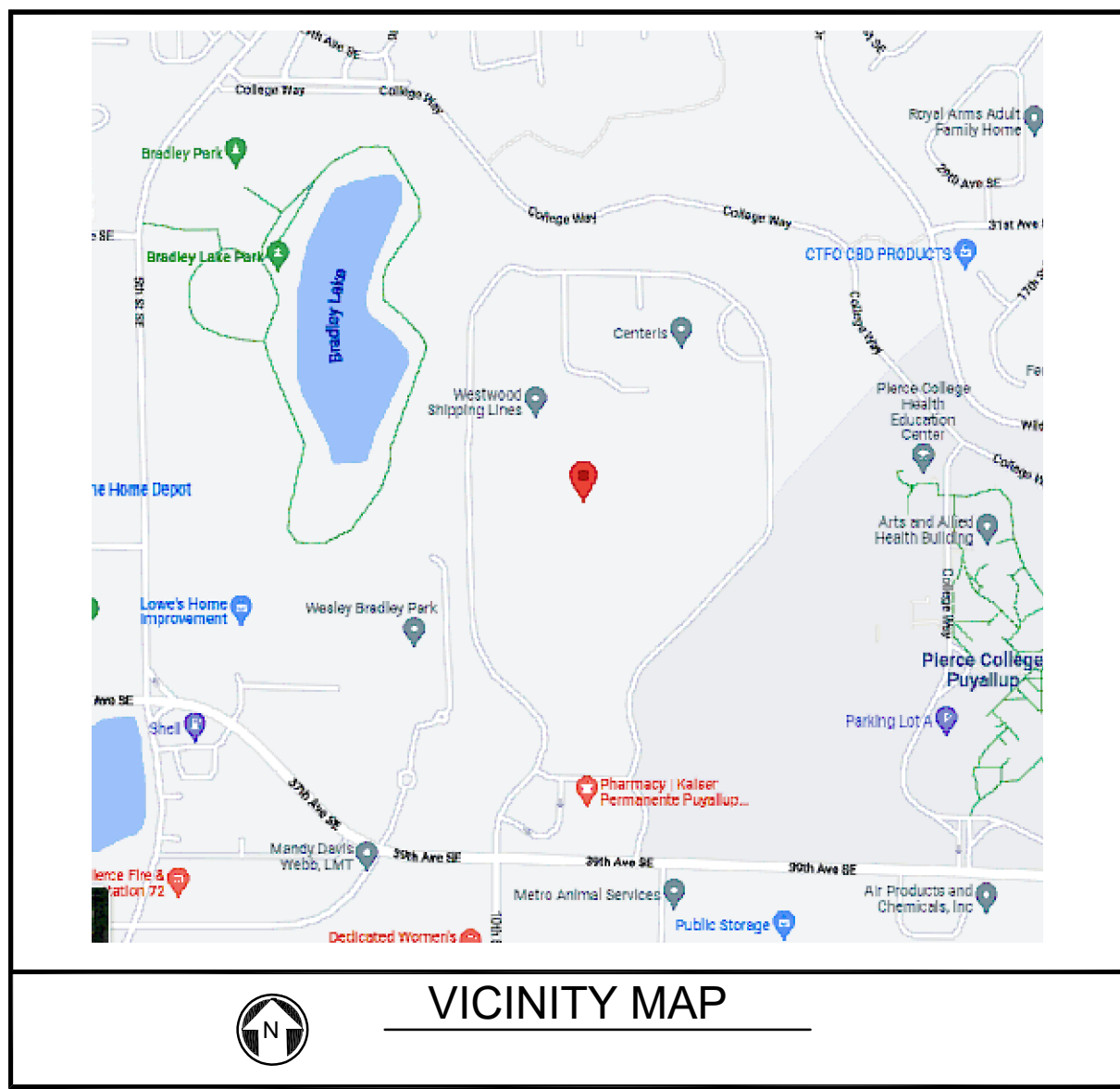

This fire alarm shop drawing was prepared for equipment application only. The information contained herein is intended to aid in the installation of this system. No design changes have been made to the engineer of record's contract documents.

Dated: 01-25-2023

Signed:

First M. Last, ET/SET
 NICET #: 95136
 NICET LEVEL IV
 FIRE ALARM SYSTEMS

CODES ADOPTED BY LOCAL AHJ
 2013 NFPA 72 NATIONAL FIRE ALARM CODE
 2018 INTERNATIONAL BUILDING CODE
 2015 NFPA 101 LIFE SAFETY CODE

BUILDING INFORMATION

ITEM1 _____
 ITEM2 _____
 ITEM3 _____

PREPARED BY: DC
 CHECKED BY: DK
 PROJECT MANAGER: DM
 DATE: 01/25/2023
 PROJECT NO: ADT-281800808
 TITLE: SYMBOLS & LEGENDS
 SHEET: FA-0.0

INITIATING WIRING

SIGNATURE LOOP WIRING LIMITATIONS:

SIGNATURE DUAL DRIVER CONTROLLER MODULES SUPPORTS UP TO 250 INTELLIGENT SIGNATURE DETECTORS AND 250 INTELLIGENT SIGNATURE MODULES

WIRE LENGTH LIMITATIONS:

NON-TWISTED, NON-SHIELDED WIRE

16AWG - 20pf/FT & 4.02 OHMS/1000 FEET
 18AWG - 20pf/FT & 6.38 OHMS/1000 FEET
 DETECTORS ONLY 16AWG - 125 DETECTORS - 9,275'
 MODULES ONLY 16AWG - 125 MODULES - 7,921'
 DETECTORS AND MODULES 16AWG - 125 OF EACH - 3,608'
 DETECTORS ONLY 18AWG - 125 DETECTORS - 5,839'
 MODULES ONLY 18AWG - 125 MODULES - 4,986'
 DETECTORS AND MODULES 18AWG - 125 OF EACH - 2,271'

TWISTED PAIR, NON-SHIELDED WIRE

16AWG - 36pf/FT & 4.02 OHMS/1000 FEET
 18AWG - 25pf/FT & 6.38 OHMS/1000 FEET
 DETECTORS ONLY 16AWG - 125 DETECTORS - 9,275'
 MODULES ONLY 16AWG - 125 MODULES - 7,921'
 DETECTORS AND MODULES 16AWG - 125 OF EACH - 3,608'
 DETECTORS ONLY 18AWG - 125 DETECTORS - 5,839'
 MODULES ONLY 18AWG - 125 MODULES - 4,986'
 DETECTORS AND MODULES 18AWG - 125 OF EACH - 2,271'

TWISTED PAIR, SHIELDED WIRE

16AWG - 82pf/FT & 4.02 OHMS/1000 FEET
 18AWG - 58pf/FT & 6.38 OHMS/1000 FEET
 DETECTORS ONLY 16AWG - 125 DETECTORS - 6,098'
 MODULES ONLY 16AWG - 125 MODULES - 6,098'
 DETECTORS AND MODULES 16AWG - 125 OF EACH - 3,608'
 DETECTORS ONLY 18AWG - 125 DETECTORS - 5,839'
 MODULES ONLY 18AWG - 125 MODULES - 4,986'
 DETECTORS AND MODULES 18AWG - 125 OF EACH - 2,271'

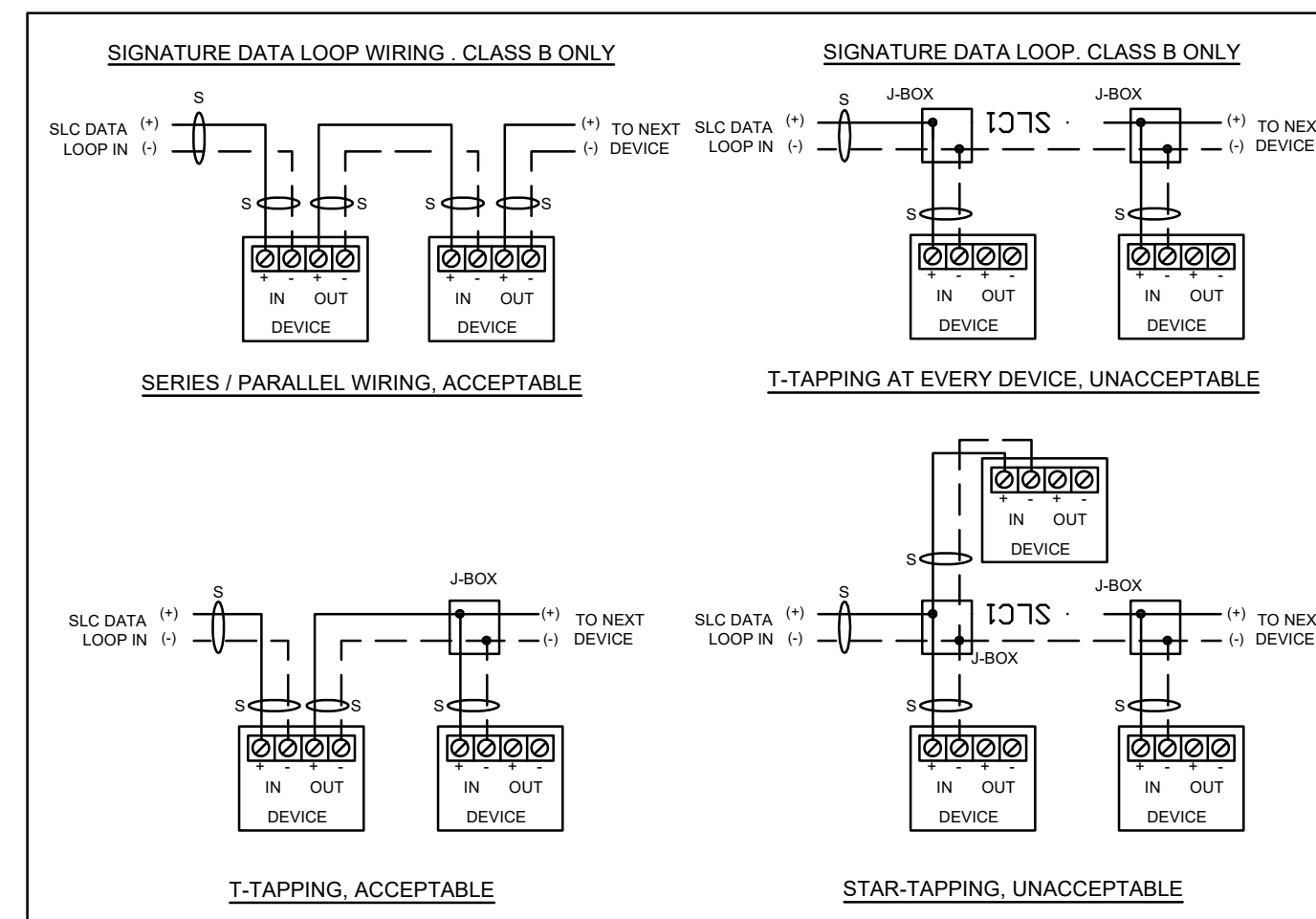

RECORD DRAWINGS

AS-BUILT / RECORD DRAWING REQUIREMENTS:

THE FOLLOWING INFORMATION SHOULD BE RECORDED ON A SEPARATE SET OF DRAWINGS FOR EACH PROJECT:

- ANY CHANGES IN THE LOCATION OF ANY ASSOCIATED FIRE ALARM OR INTERFACE EQUIPMENT, CONTROL PANELS, ANNUNCIATORS, DETECTORS, CONTROL RELAYS, INPUT AND OUTPUT MODULES, TERMINAL CABINETS, ETC.
- ANY CHANGES TO CIRCUIT WIRING. THIS INCLUDES DELETION OR ADDITIONAL WIRING RUNS. ANY RE-ROUTING OF CIRCUIT WIRING. ANY ADDITIONS OR DELETIONS TO THE NUMBER, LOCATION, AND ORDER OF DEVICE WIRING ON A CIRCUIT.
- ADDRESSES AND/OR LABELS FOR ALL ADDRESSABLE DEVICES.
- CANDELA SETTINGS OF ALL VISUAL NOTIFICATION DEVICES.
- WATTAGE TAP SETTINGS OF ALL SPEAKER NOTIFICATION DEVICES.

ANY CHANGES SHALL BE DISCUSSED WITH CONVERGINT PROJECT MANAGER TO ENSURE SYSTEM AND CODE PARAMETERS ARE MET. CONVERGINT SHALL NOT BE HELD ACCOUNTABLE FOR CHANGES MADE WITHOUT APPROVAL.

THIS INFORMATION SHALL BE NEAT AND LEGIBLE WHEN PRESENTED TO THE TECHNICIAN AT THE CONCLUSION OF THE PROJECT. PLEASE NOTE CONTACT INFORMATION ON DRAWINGS FOR INDIVIDUALS WITH FAMILIARITY OF INSTALLATION IN THE EVENT QUESTIONS ARISE DURING THE CLOSEOUT PROCESS.

CLASS A OR B NOTIFICATION WIRING

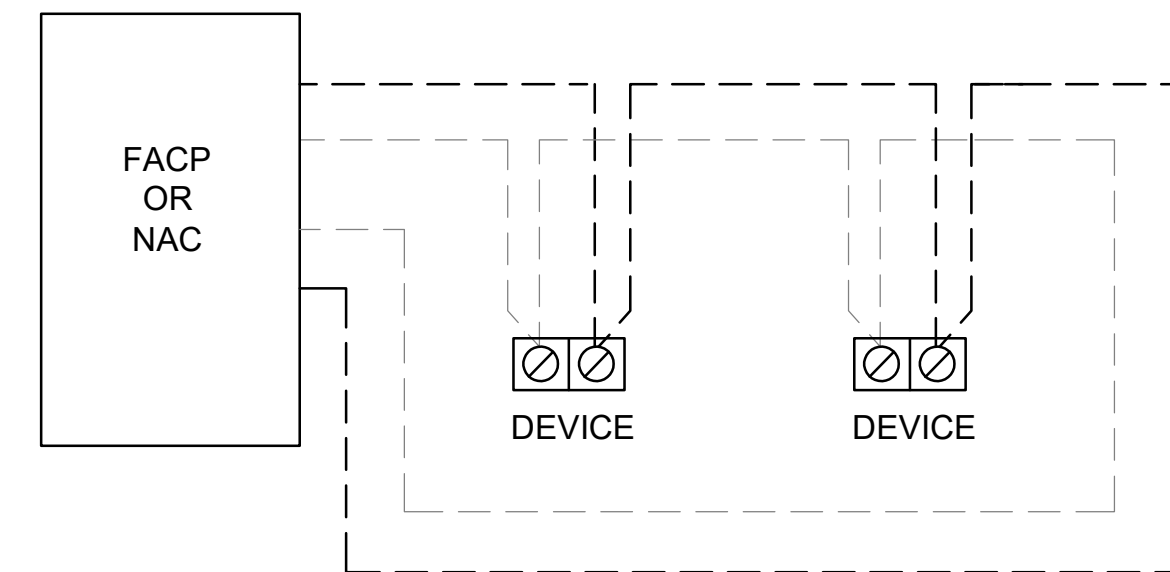
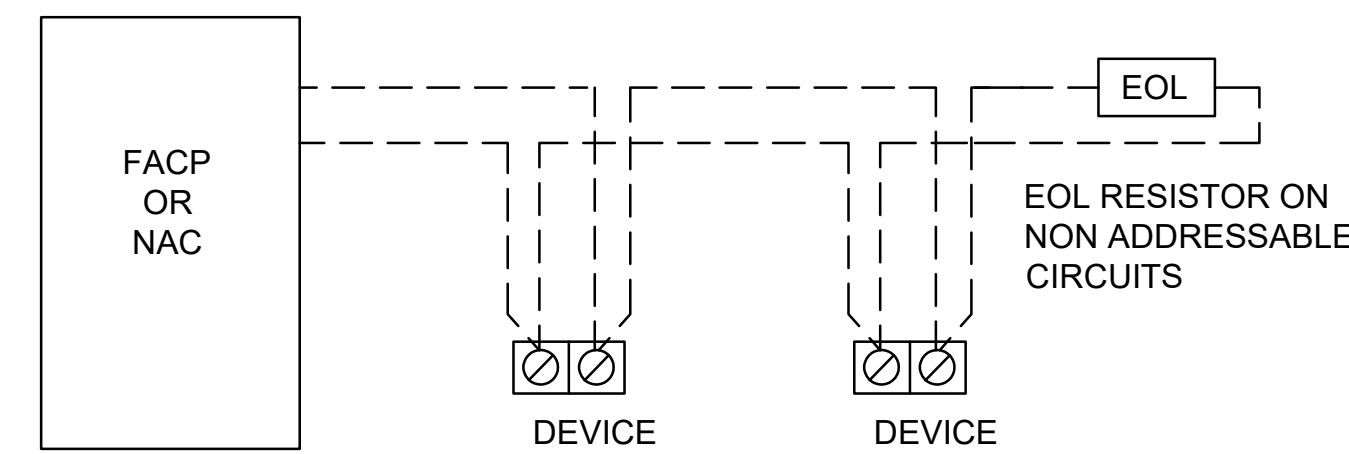

SEPARATION OF CLASS A CIRCUITS - INSTALLATION EXCEPTIONS:

CLASS A OUTGOING AND RETURN CONDUCTORS, EXITING AND RETURNING TO THE CONTROL PANEL, ARE TO BE ROUTED SEPARATELY. THE MINIMUM RECOMMENDED SEPARATION IS 1 FT. VERTICALLY AND 4 FT. HORIZONTALLY. THE FOLLOWING EXCEPTIONS STILL DO NOT ELIMINATE THE 2ND PAIR OF WIRES. THEY ALLOW YOU TO USE A SINGLE RACEWAY AND ELIMINATE THE SEPARATION FOR THESE CONDITIONS.

- WHEN MAXIMUM CABLE, ENCLOSURE, OR RACEWAY IS LESS THAN 10 FEET. NO LIMIT TO NUMBER OF DEVICES.
- UNLIMITED CONDUIT OR RACEWAY DROP TO AN INDIVIDUAL DEVICE.
- UNLIMITED CONDUIT OR RACEWAY DROP TO A ROOM NOT EXCEEDING 1000 SQ. FT. NO LIMIT TO THE NUMBER OF DEVICES.

NOTIFICATION WIRING

SPEAKER CIRCUIT WIRING LIMITATIONS:

WIRE LENGTH LIMITATIONS:

THE MAXIMUM ALLOWABLE WIRE LENGTH IS THE FARTHEST DISTANCE THAT A SPEAKER CIRCUIT CAN EXTEND FROM THE AMPLIFIER TO THE LAST SPEAKER WITHOUT LOSING 0.5 dB OF SIGNAL. THE FOLLOWING ARE MAXIMUM DISTANCE BASED ON APPROXIMATE WATTAGE OF THE SPEAKER CIRCUIT. CIRCUIT LENGTHS ARE FURTHER BASED ON ORIGINATION OF A CIRCUIT FROM EITHER THE AMPLIFIER OR FROM THE CC1 MODULE.

ALLOWABLE LENGTH AT 25 Vrms, WITH 0.5 dB LOSS

16AWG - 20 WATTS - 231'
 16AWG - 30 WATTS - 154'
 16AWG - 40 WATTS - 116'

ALLOWABLE LENGTH AT 70 Vrms, WITH 0.5 dB LOSS

16AWG - 20 WATTS - 1815'
 16AWG - 30 WATTS - 1210'
 16AWG - 40 WATTS - 907'

NAC CIRCUIT (HORN, STROBE) WIRING LIMITATIONS:

FOR 24VDC SYSTEMS, MINIMUM DEVICE OPERATING VOLTAGE IS 16VDC. VOLTAGE DROP CALCULATIONS ARE BASED ON 16VDC AND POWER SUPPLY DE-RATED AND ON DEPLETED BATTERY BACKUP PER THE PRESCRIBED PERIOD OF STANDBY AND ALARM RING TIME. THE VOLTAGE DROP WILL LIMIT THE CIRCUITS CAPACITY IN ALMOST ALL CASES AND CURRENT CANNOT BE USED AS THE ONLY CIRCUIT WIRING LIMITATION. ALTERATIONS TO CIRCUIT LENGTH FROM THOSE CALCULATED MAY CAUSE CIRCUITS TO BE OUT OF THE TOLERANCES GRANTED BY THE FIRE ALARM CODE. CHANGES TO DEVICE LOCATION OR CIRCUIT LENGTH SHALL BE COMMUNICATED TO THE CONVERGINT TEAM.

NAC CIRCUIT WIRING AND ROUTING MUST NOT EXCEED WHAT IS SHOWN ON THE DESIGN DRAWINGS AND CALCULATIONS. A VOLTAGE DROP TEST IS PART OF MOST FIRE FINALS AND IS REQUIRED BY NFPA. A FAILED FIRE FINAL MAY REQUIRE REWIRING OF THE FAILED CIRCUITS.

WIRE RESISTANCE RATINGS USED FOR CALCULATIONS:

18AWG - 13 OHMS PER 1000'
 16AWG - 8 OHMS PER 1000'
 14AWG - 5.2 OHMS PER 1000'

EXAMPLE: 1.0 AMP CIRCUIT LOAD USING #14 WIRE = 409 FEET MAXIMUM.

MOUNTING HEIGHTS

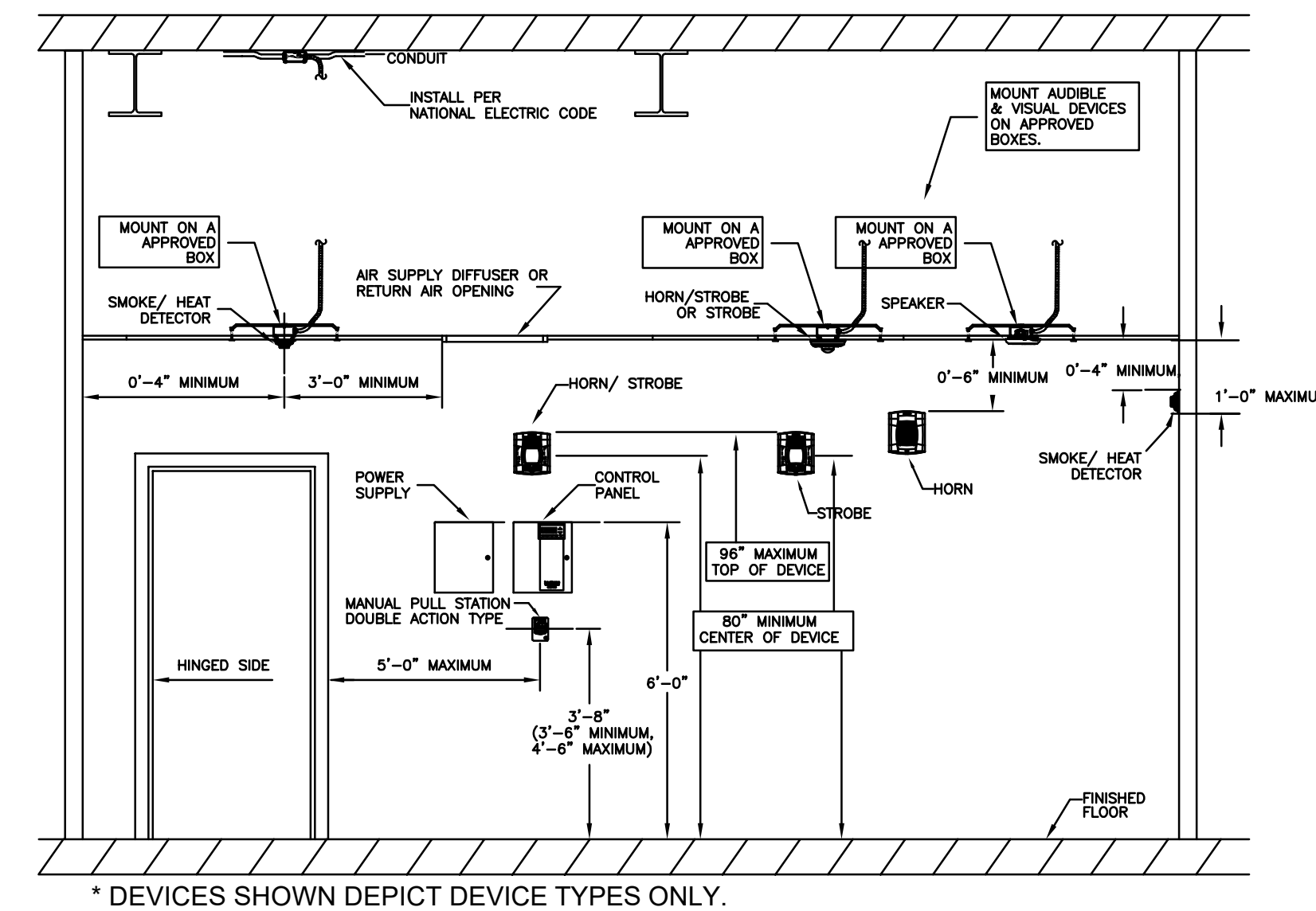

* DEVICES SHOWN DEPICT DEVICE TYPES ONLY.
 NFPA 72 AND ADA DEVICE
 INSTALLATION REQUIREMENTS



21312 30TH DRIVE SE
 BOTHELL, WA 98021
 P: 425-486-2600 F: 425-486-2611
 WA LIC# ADTCCOCL801UQ



1015 39TH AVE SE
 PUYALLUP, WA 98374
 FIRE ALARM SYSTEM

REVISIONS		
NO.	DATE	REVISION
Δ	01-25-2023 BY: DC	FOR PERMIT
Δ	BY: _	-
Δ	BY: _	-
Δ	BY: _	-
Δ	BY: _	-
Δ	BY: _	-
Δ	BY: _	-
Δ	BY: _	-

This fire alarm shop drawing was prepared for equipment application only. The information contained herein is intended to aid in the installation of this system. No design changes have been made to the engineer of record's contract documents.

Dated: 01-25-2023

Signed: _____

First M. Last, ET/SET
 NICET #: 95136
 NICET LEVEL IV
 FIRE ALARM SYSTEMS

CODES ADOPTED BY LOCAL AHJ

2013 NFPA 72 NATIONAL FIRE ALARM CODE
 2018 INTERNATIONAL BUILDING CODE
 2015 NFPA 101 LIFE SAFETY CODE

BUILDING INFORMATION

ITEM1 _____
 ITEM2 _____
 ITEM3 _____

PREPARED BY: DC

CHECKED BY: DK

PROJECT MANAGER: DM

DATE: 01/25/2023

PROJECT NO: ADT-281800808

TITLE: WIRING INFORMATION

SHEET: FA-0.1



REVISIONS

NO.	DATE	REVISION
△	01-25-2023 BY: DC	FOR PERMIT
△	BY: _	-
△	BY: _	-
△	BY: _	-
△	BY: _	-
△	BY: _	-
△	BY: _	-

This fire alarm shop drawing was prepared for equipment application only. The information contained herein is intended to aid in the installation of this system. No design changes have been made to the engineer of record's contract documents.

Dated: 01-25-2023

Signed: _____
First M. Last, ET/SET
NICET #: 95136
NICET LEVEL IV
FIRE ALARM SYSTEMS

CODES ADOPTED BY LOCAL AHJ

2013 NFPA 72 NATIONAL FIRE ALARM CODE
2018 INTERNATIONAL BUILDING CODE
2015 NFPA 101 LIFE SAFETY CODE

BUILDING INFORMATION

ITEM1 _____
ITEM2 _____
ITEM3 _____

PREPARED BY: DC

CHECKED BY: DK

PROJECT MANAGER: DM

DATE: 01/25/2023

PROJECT NO: ADT-281800808

TITLE: WIRING DETAILS
RISER DIAGRAM
CALCS

SHEET: FA-0.2

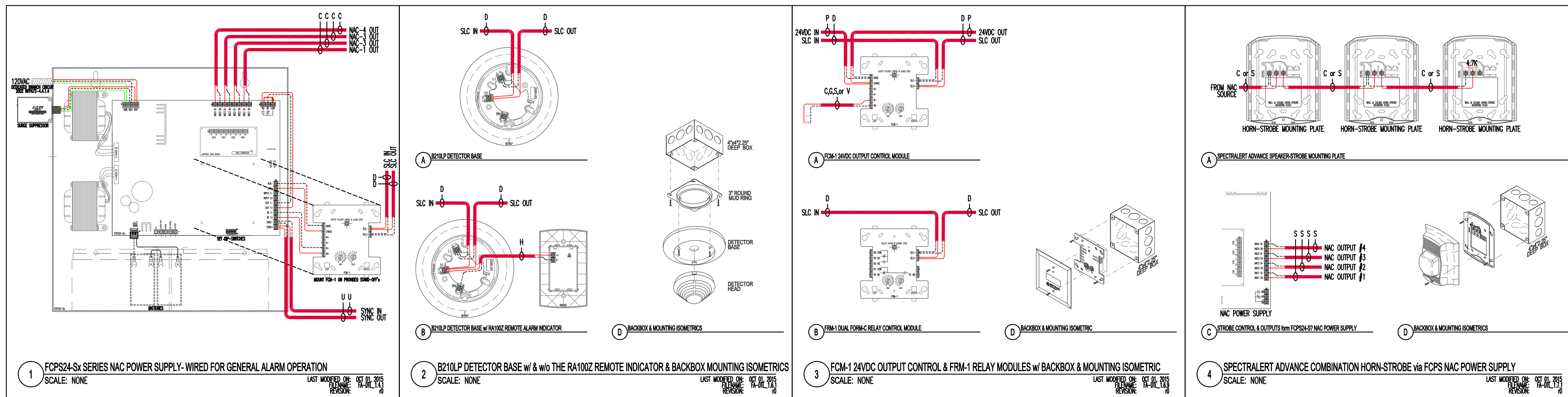

FACP1 PSE-10													Circuit Alarm Sup. Current	Total devices per circuit	Circuit Length (feet)	Circuit Ohms	Circuit EOL VDC	Results
Circuit	Location	Circuit Starting VDC	Wire AWG	Device & Qty.	Device & Qty.	Device & Qty.	Device & Qty.	Device & Qty.	Device & Qty.	Device & Qty.	Device & Qty.	Device & Qty.						
NAC1	MULTIPURPOSE ROOM	20.4	14	PC2WL30 2	PC2WL75 2	PC2WL95 6							1.46 0.00	10.00	50	0.26	20.0	OK
NAC2		20.4	14	PC2WL30 1	PC2WL75 2	PC2WL95 5	SCWL15 3						1.32 0.00	11.00	0	0.00	20.4	OK
NAC3		20.4	14	PC2WL30 3	PC2WL75 2	PC2WL95 4	SCWL15 7	SCWL30 2					1.63 0.00	18.00	0	0.00	20.4	OK
SPARE		20.4	14										0.00 0.00	0.00	0	0.00	20.4	OK
SUPPLIED AMPS:				Field Alarm Current in Amps:									REMAINING AMPS:					
10.00 A				4.41 A									5.59 A					

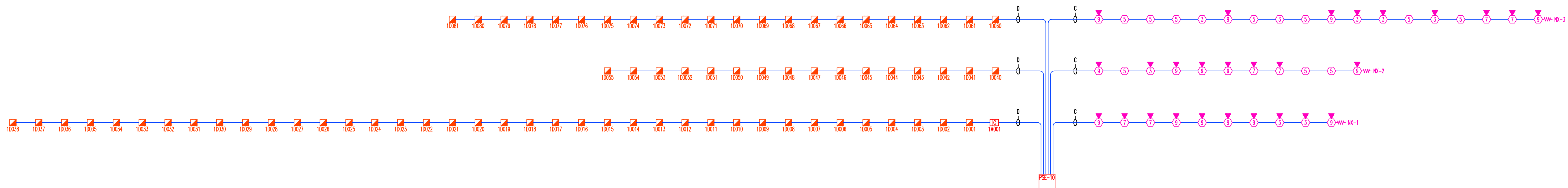



REVISIONS		
NO.	DATE	REVISION
△	01-25-2023 BY: DC	FOR PERMIT
△	BY: _	-
△	BY: _	-
△	BY: _	-
△	BY: _	-
△	BY: _	-
△	BY: _	-

This fire alarm shop drawing was prepared for equipment application only. The information contained herein is intended to aid in the installation of this system. No design changes have been made to the engineer of record's contract documents.

Dated: 01-25-2023

Signed:
 First M. Last, ET/SET
 NICET #: 95136
 NICET LEVEL IV
 FIRE ALARM SYSTEMS

CODES ADOPTED BY LOCAL AHJ
 2013 NFPA 72 NATIONAL FIRE ALARM CODE
 2018 INTERNATIONAL BUILDING CODE
 2015 NFPA 101 LIFE SAFETY CODE

BUILDING INFORMATION
 ITEM1 _____
 ITEM2 _____
 ITEM3 _____

PREPARED BY: DC

CHECKED BY: DK

PROJECT MANAGER: DM

DATE: 01/25/2023

PROJECT NO: ADT-281800808

TITLE:
**FIRE ALARM FLOOR
 PLAN LAYOUT**

SHEET: FA-1.1

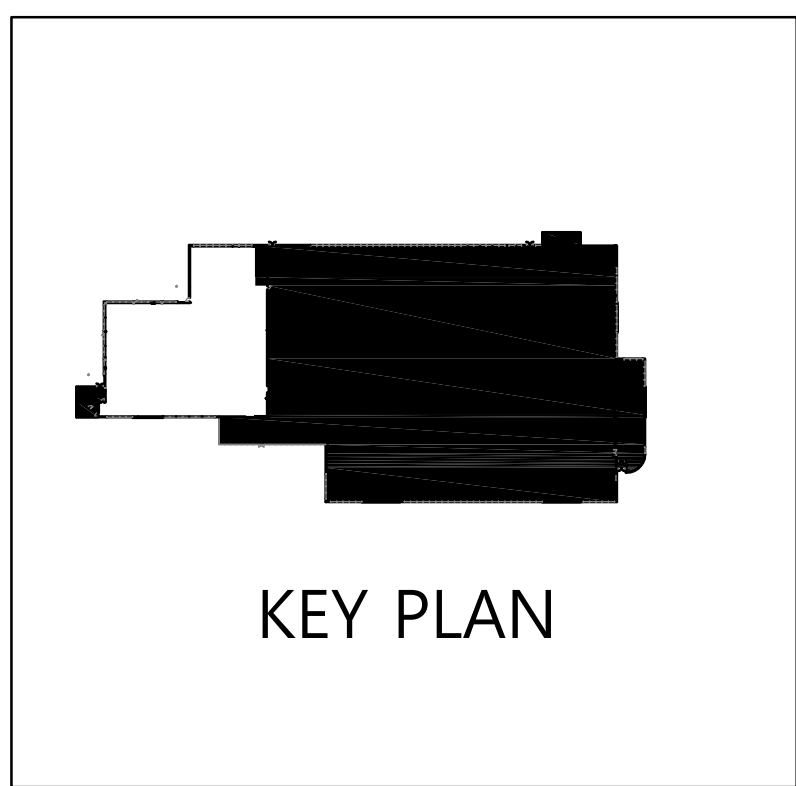

KEY PLAN