

PROJECT: TOYOTA CANTOPY			SHEET NO. 1/8
BY: CF	DATE: 1/24/24	JOB NO. 24002	

PRCA20240148

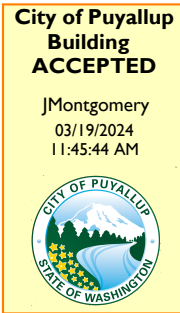

FULL SIZED LEDGIBLE REPORT IS
REQUIRED TO BE PROVIDED BY THE
PERMITTEE ON SITE FOR ALL
INSPECTIONS

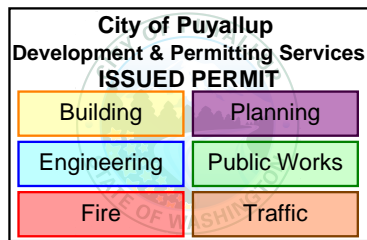

STRUCTURAL CALCULATIONS
FOR THE
TOYOTA OF PUYALLUP
CANTOPY
(1400 RIVER RD E)

- LAHWAY

DESIGN PARAMETERS: 2018 IRC
97 mph EXP "B"
SEISMIC CAT "D"
SITE WIND AS = 25 psf





ASCE 7 Hazards Report

Address:
Puyallup
Washington,

Standard: ASCE/SEI 7-22
Risk Category: II
Soil Class: Default

Latitude: 47.19044
Longitude: -122.29537
Elevation: 45.776816077718955 ft (NAVD 88)

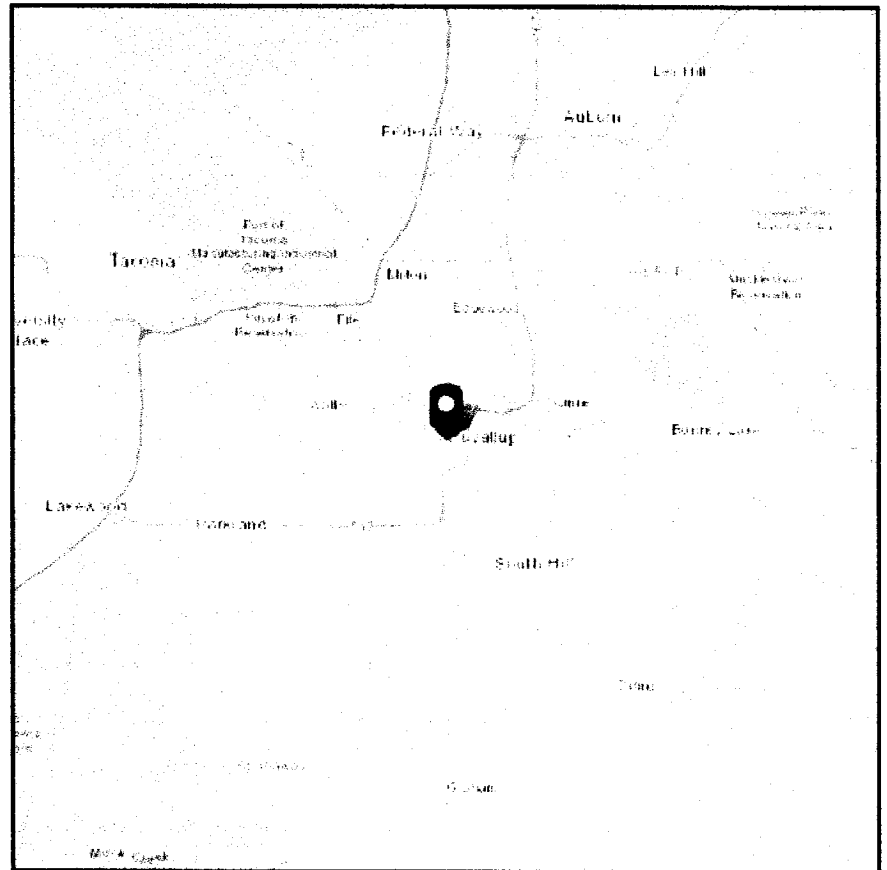
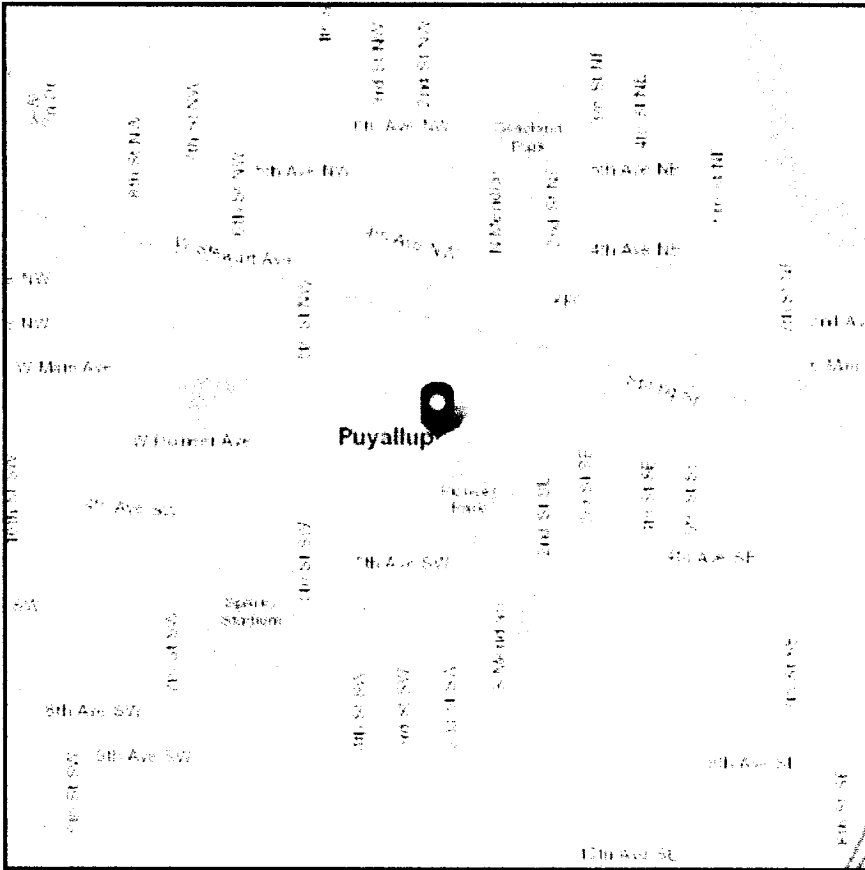

Wind

Results:

Wind Speed	97 Vmph
10-year MRI	67 Vmph
25-year MRI	73 Vmph
50-year MRI	78 Vmph
100-year MRI	83 Vmph
300-year MRI	92 Vmph
700-year MRI	97 Vmph
1,700-year MRI	104 Vmph
3,000-year MRI	108 Vmph
10,000-year MRI	118 Vmph
100,000-year MRI	136 Vmph
1,000,000-year MRI	154 Vmph

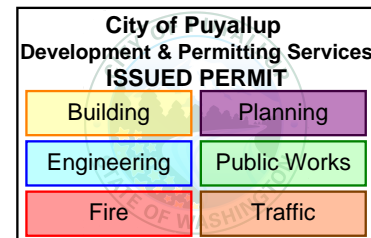

Data Source:

ASCE/SEI 7-22, Fig. 26.5-1B and Figs. CC.2-1-CC.2-4, and Section 26.5.2

Date Accessed:

Fri Dec 01 2023



Value provided is 3-second gust wind speeds at 33 ft above ground for Exposure C Category, based on linear interpolation between contours. Wind speeds are interpolated in accordance with the 7-22 Standard. Wind speeds correspond to approximately a 7% probability of exceedance in 50 years (annual exceedance probability = 0.00143, MRI = 700 years). Values for 10-year MRI, 25-year MRI, 50-year MRI and 100-year MRI are Service Level wind speeds, all other wind speeds are Ultimate wind speeds.

Site is not in a hurricane-prone region as defined in ASCE/SEI 7-22 Section 26.2.

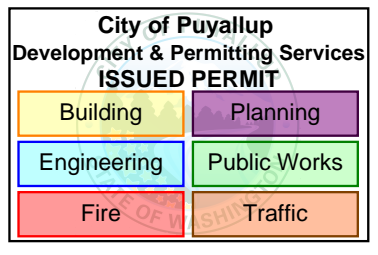

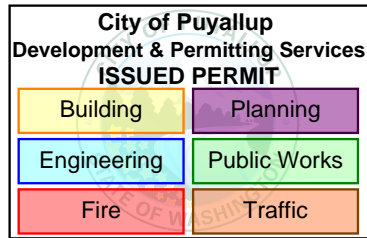

Site Soil Class: Default

Results:

PGA _M :	0.56	T _L :	6
S _{MS} :	1.59	S _S :	1.44
S _{M1} :	0.91	S ₁ :	0.43
S _{DS} :	1.06	V _{S30} :	260
S _{D1} :	0.61		

Seismic Design Category: D

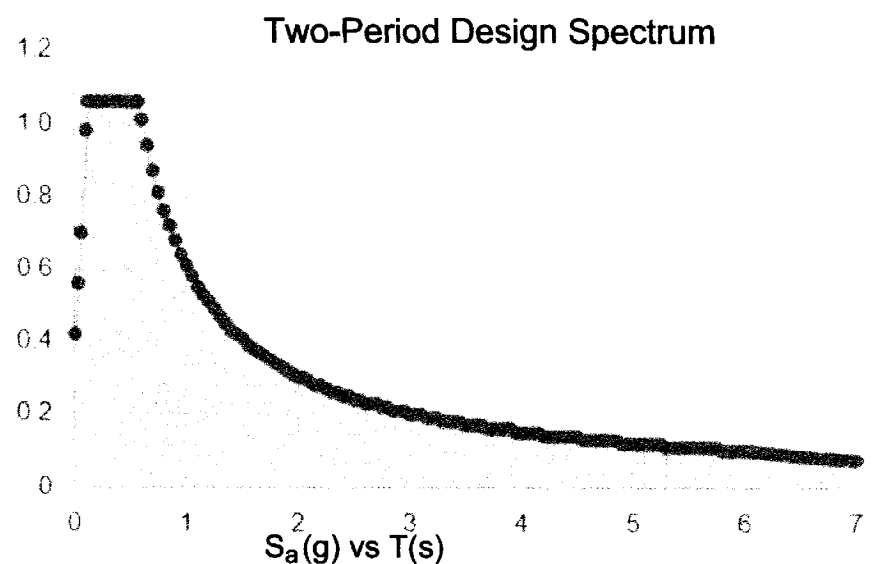
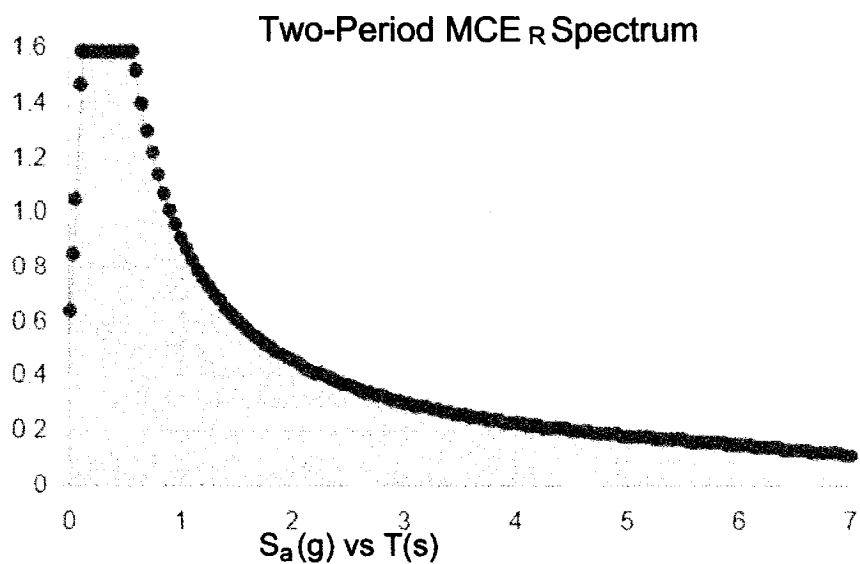
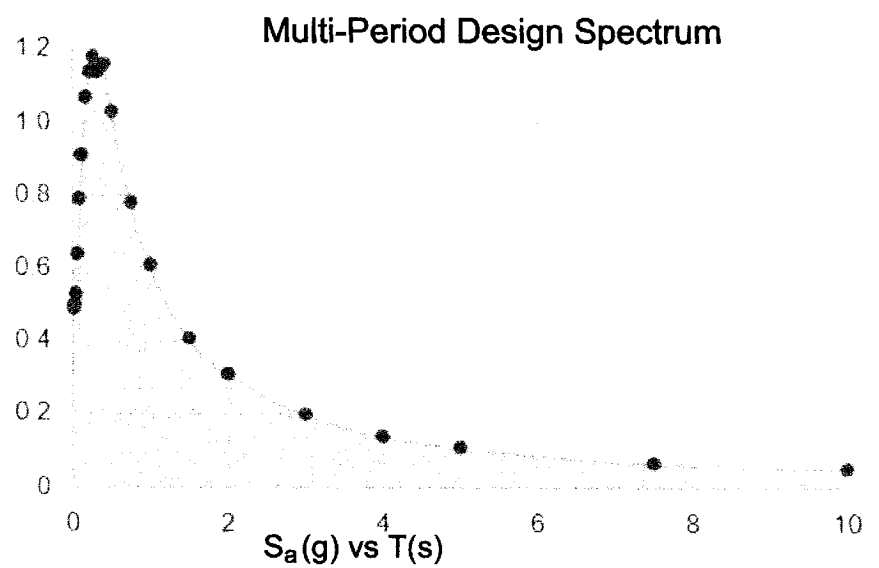
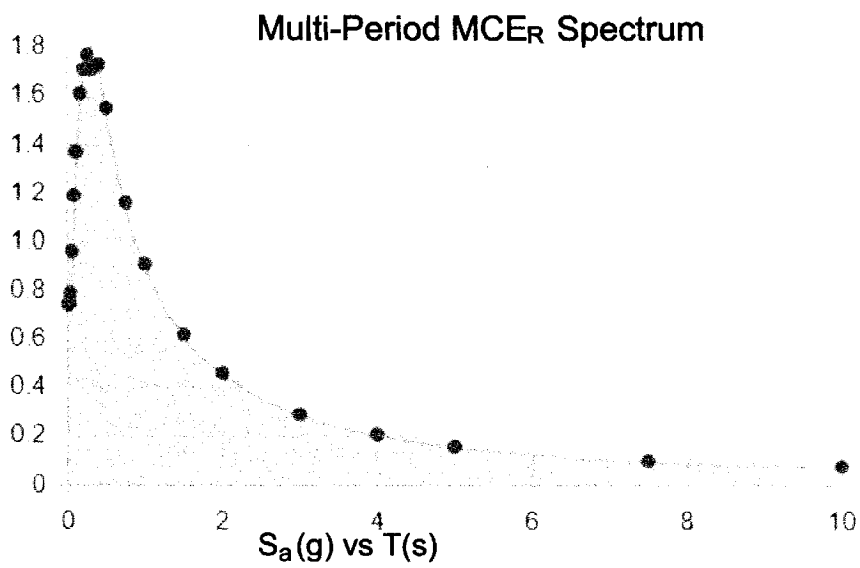

MCE_R Vertical Response Spectrum

Vertical ground motion data has not yet been made available by USGS.

Design Vertical Response Spectrum

Vertical ground motion data has not yet been made available by USGS.

PROJECT:			SHEET NO. 6/8
BY:	DATE:	JOB NO. 24002	

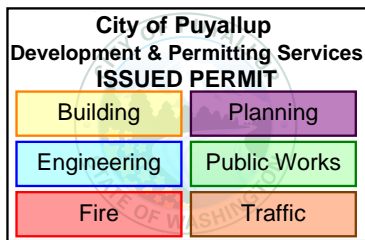

$h = 12'$

$W = 0.15(16)240 = 6.12k$

$V = 1.000 / 1.25(1A) W = 1.61W$

$V = 1.61(6.12) / 2 = 1.19k$

$M = 1.19(12)12 = 279k'$

$SPEED = 279 / 46(6) = 9.9 \omega$

USE 5x5x1/2

3'0" ϕ x 5' DRABO

$d = \sqrt{\frac{4.25(1900)(12)}{2000(3)}} = 4.0$

USE 3'0" ϕ x 4'6" DRABO

PROJECT:			SHEET NO.
BY:	DATE:	JOB NO.	6/e
		24002	

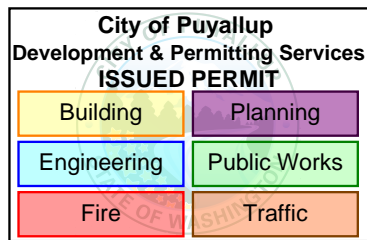

$l = 14'$

$w = 0.04(9) = 0.36 \text{ lb}$

$M = \frac{0.36(14)^2}{8} = 106 \text{ k}''$

$S_{req} = \frac{106}{24(1.15)} = 38.3 -$
 $5\frac{1}{2}'' \times 15''$

$l = 5\frac{1}{2}' \text{ CATCH}$

$w = 0.36 \text{ lb}$

$M = \frac{0.36(5.5)^2}{8} = 65.3 \text{ k}''$

$S_{req} = \frac{65.3}{1.85(1.15)} = 30.7 -$
 $5\frac{1}{2}'' \times 15''$

PROJECT:		SHEET NO.
BY:	DATE:	JOB NO.
		24052
		7/16

City of Puyallup Development & Permitting Services ISSUED PERMIT	
Building	Planning
Engineering	Public Works
Fire	Traffic

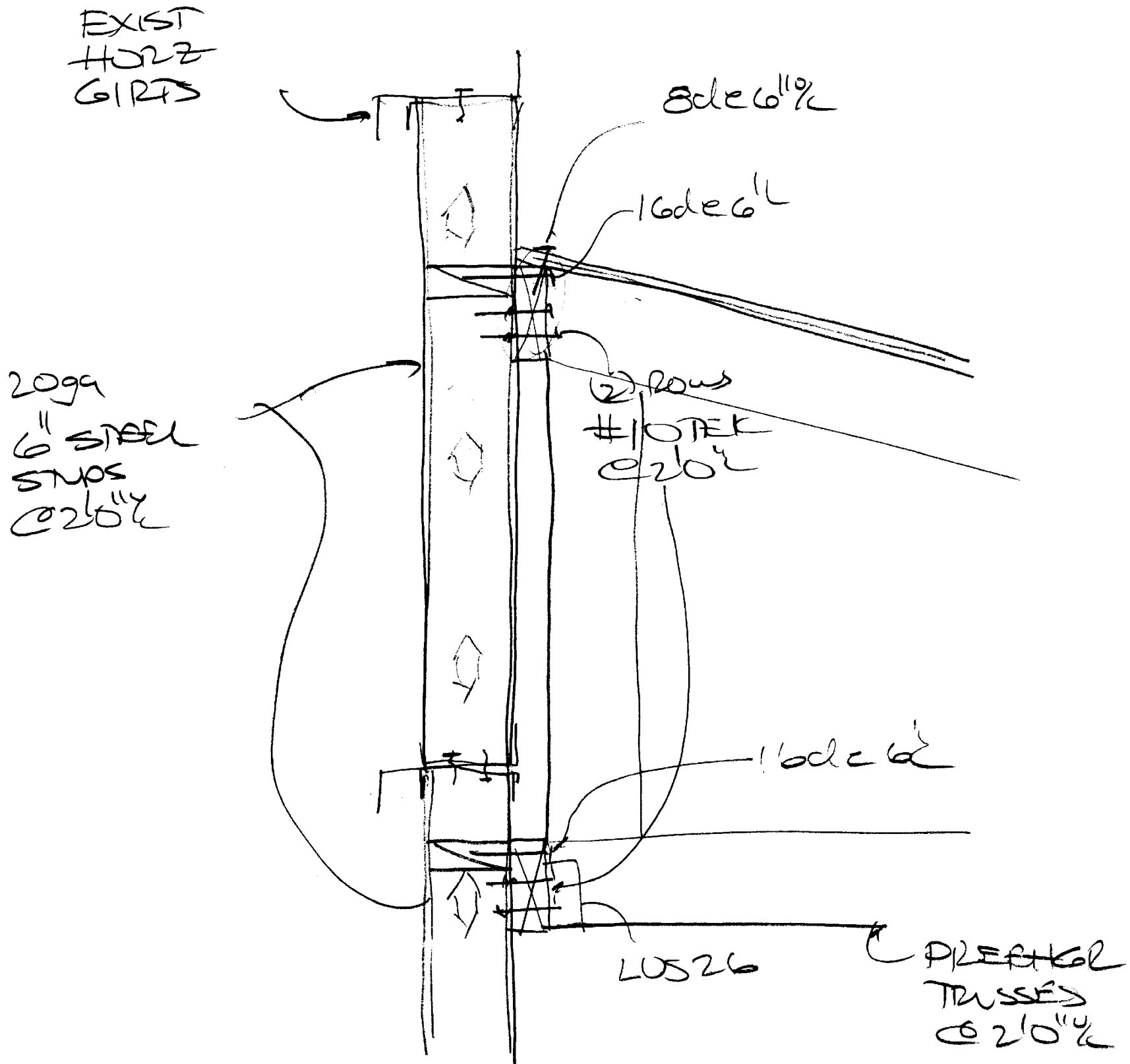

SK1

PROJECT:		SHEET NO.
BY:	DATE:	JOB NO. 24002
		8/E

City of Puyallup
Development & Permitting Services
ISSUED PERMIT

Building	Planning
Engineering	Public Works
Fire	Traffic

