



Stormwater Site Plan

PREPARED FOR:

AWB Engineers
1942 Northwood Drive
Salisbury, MD 21801

PROJECT:

CPFD Puyallup
322 Valley Ave NW
Puyallup, WA 98371
2230491.11

PREPARED BY:

Zachary Perdue, EIT
Project Engineer

REVIEWED BY:

Todd C. Sawin, PE, DBIA, LEED AP
Principal

DATE:

February 2024

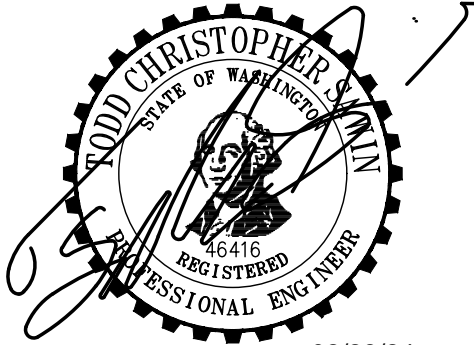

02/28/24

I hereby state that this [Stormwater Site Plan](#) for the [CPFD](#) project has been prepared by me or under my supervision and meets the standard of care and expertise that is usual and customary in this community for professional engineers. I understand that [the City of Puyallup](#) does not and will not assume liability for the sufficiency, suitability, or performance of drainage facilities prepared by me.

Stormwater Site Plan

PREPARED FOR:

AWB Engineers
1942 Northwood Drive
Salisbury, MD 21801

PROJECT:

CPFD Puyallup
322 Valley Ave NW
Puyallup, WA 98371
2230491.11

PREPARED BY:

Zachary Perdue, EIT
Project Engineer

REVIEWED BY:

Todd C. Sawin, PE, DBIA, LEED AP
Principal

DATE:

February 2024

Table of Contents

Section	Page
1.0 Project Overview	1
1.1 Purpose and Scope.....	1
1.2 Existing Conditions Summary	1
1.2.1 Existing Site Features	1
1.2.2 Soils	1
1.3 Proposed Conditions Summary	2
2.0 Offsite Analysis Report	2
2.1 Upstream Analysis	2
2.2 Downstream Analysis.....	2
3.0 Permanent Stormwater Control Plan	2
4.0 Summary of Minimum Requirements	3
4.1 MR 1 – Preparation of Stormwater Site Plans	3
4.2 MR 2 - Construction Stormwater Pollution Prevention	3
4.3 MR 3 – Source Control of Pollution.....	3
4.4 MR 4 – Preservation of Natural Drainage Systems and Outfalls.....	4
4.5 MR 5 – Onsite Stormwater Control	4
4.6 MR 6 – Runoff Treatment	4
4.7 MR 7 – Flow Control	5
4.8 MR 8 – Wetland Protection	5
4.9 MR 9 – Operation and Maintenance	5
5.0 Construction Stormwater Pollution Prevention Plan	5
6.0 Special Reports and Studies	5
7.0 Other Permits	5
8.0 Operations and Maintenance Manual	5
9.0 Conclusion.....	6

Appendices

Appendix A

Exhibits

- A-1..... Vicinity Map
- A-2..... Existing Conditions Map
- A-3..... NRCS Soil Survey
- A-4..... Developed Conditions Map
- A-5..... Flow Chart for Determining Requirements for Redevelopment
- A-6..... FEMA Flood Map
- A-7..... Downstream As-Builts

Appendix B

- Geotechnical Engineering Report – GeoEngineers

Appendix C

Maintenance Report

- Attachment 1: City of Puyallup Private Stormwater Facility Maintenance
- Attachment 2: Biopod System Inspection & Maintenance Guide

Appendix D

Drainage Calculations

- D-1..... Water Quality WWHM Report
- D-2..... Biopod Department of Ecology Design Sheet and Calculations
- D-3..... Conveyance Calculations and Analysis

Appendix E

CSWPPP

1.0 Project Overview

1.1 Purpose and Scope

This Stormwater Site Plan accompanies the site development plans for the CPFDF expansion project, located on Tax Parcel 0420215019. The site is bordered by Valley Avenue East to the north, a commercial business, CarMax, to the east and north, another commercial business to the west, Comcast, and WSDOT SR167 ROW is located to the south of the site, the road to the south of the site is north Levee Road. Approximately 2.3 acres of the existing 5 acre site will be disturbed. Refer to Appendix A, Figure A-1 for a Vicinity Map.

This Stormwater Site Plan is for storm drainage approval. This report describes the design and analysis of the basic treatment and storm conveyance facilities proposed as part of the site improvements. This report will demonstrate that the stormwater design for this project will meet the requirements of the 2019 Department of Ecology (DOE) *Stormwater Management Manual for Western Washington (SMMWW)*, as adopted by the City of Puyallup.

1.2 Existing Conditions Summary

1.2.1 Existing Site Features

The existing area is approximately 5 acres and is currently developed. Within the parcel, asphalt parking lot makes up approximately 1.43 acres, concrete paving makes up 0.25 acres, grass lawn covers 2.86 acres, and the final 0.46 acres is encompassed by the existing building. 0.46 acres are considered nonpollution generating impervious surface. 1.68 acres is composed of pollution generating impervious surface. The last 2.86 acres are nonpollution generating pervious surface.

A topographic survey of the project site area was prepared by AHBL that shows existing site conditions and elevations. See Appendix A, Exhibit A-2 for the Existing Conditions Map.

1.2.2 Soils

The Natural Resources Conservation Service (NRCS) classifies the onsite soils as Puyallup fine sandy loam – 31A and Sultan silt loam – 42A. Appendix A, Exhibit A-4 provides the NRCS soil map. Puyallup fine sandy loam soils are classified as hydrologic soil Series A, which typically have low erosion and high infiltration potential. Sultan silt loam are classified as hydrologic soil Series C, which typically have moderate erosion and moderate infiltration potential.

In addition to the NRCS information, GeoEngineers prepared a geotechnical report for the site on January 5, 2024. The soils encountered onsite by GeoEngineers contained a significant percentage of fines. In their report they conclude that “the infiltration rate of the silt alluvium would be considered very low or practically infeasible”. Consequently, they do not recommend using infiltration as a solution for stormwater control.

See Appendix B for the Geotechnical Engineering Report.

1.3 Proposed Conditions Summary

The proposed improvements include new building and expand stormwater management system to accommodate additional impervious surface. The proposed site will consist of 0.83 acres of grass, 1.78 acres of asphalt parking, 0.15 acres concrete, and 1.45 acres of building. 0.31 acres of existing asphalt to be demolished. 0.43 acres of new asphalt to be paved. Of the proposed developments 1.78 acres will be impervious pollution generating surfaces. 1.60 acres is to be impervious nonpollution generating surface. The rest of the proposed site is to be 0.83 acres of pervious nonpollution generating surface.

Since this existing conveyance system discharges directly to the Puyallup River, no flow control (MR7) is required per Appendix I-A of Volume I of the *SMMWW*.

See Appendix A, Exhibit A-4, for the Developed Conditions Map.

2.0 Offsite Analysis Report

2.1 Upstream Analysis

There is no proposed upstream basin. An upstream pond exists along the southern border of the site adjacent to the southwest property corner. This bioretention cell is to be left as is and is not to be disturbed. The existing bioretention pond is to be protected and will be outside of project clearing limits. The project parcel is bordered by Valley Ave E to the north. Commercial businesses border to the east and west. To the south there is an existing gravel access road to another parcel. Valley Ave E has its collection system draining away from the project. The bordering commercial areas have their own stormwater management systems and do not discharge onto the project site. Per the topographic survey performed on the existing site, along with field observations, the remaining parcels that border the proposed storage lot do not discharge any significant amount of stormwater onto the project site.

2.2 Downstream Analysis

The existing site has onsite storm collection and conveyance systems. There are two existing bioretention ponds onsite for stormwater treatment. The stormwater from the site drains to both bioretention ponds through catch basins and conveyance pipes or sheet flow. The stormwater in the bioretention ponds is treated and then conveyed to the southern border of the site where there is a stormwater manhole draining to a 36" stormwater line. This 36" stormwater line flows to the southeast for 461 feet before transitioning to a 72" line. The 72" storm line then drains south for 743 feet before out falling into the Puyallup river. See appendix A-7 for downstream as-builts.

Projects that discharge surface water runoff indirectly to the Puyallup River, through a municipal storm sewer system, are exempt from enhanced treatment and flow control requirements per Appendices I-D and I-A of the *SMMWW*. Refer to Sections 4.6 and 4.7 for information on the proposed water quality and flow control plans.

3.0 Permanent Stormwater Control Plan

This project is a redevelopment project that includes more than 5,000 square feet of impervious surfaces (>70,000 SF); therefore, all Minimum Requirements (MR) apply to this project. Refer to Appendix A, Exhibit A-5, for the Flow Chart for Determining Requirements for Redevelopment.

Existing bioswales, and both raingardens are to be removed. The roof basins are to be connected into the onsite storm pipe conveyance network. Existing trench drain to be extended south. New catch basins are to installed to expand on the existing stormwater conveyance system. Existing

foundation drain to be removed within the footprint of the building expansion. Existing and proposed foundation drains will be connected to each other and will utilize existing daylight or new connection to system will be provided. New roof drainpipe to be installed around building perimeter along the north, south and east sides. Roof drainpipes to connect into stormwater conveyance system. The roof is not a pollution generating surface, however, the roof drains to the storm conveyance system then to the stormwater treatment structure. The stormwater treatment structure is sized to accommodate runoff from the roof. Providing a larger stormwater treatment structure to accommodate roof runoff will offset the costs associated with bypass conveyance lines and will ease constructability of utilities adjacent to the building's footprint. To treat runoff from the parking lot an 8' by 16' biopod biofilter underground vault system is to be installed.

Refer to Sections 4.6 and 4.7 for more information on the proposed water quality and flow control plans. Refer to appendix D, exhibit D-3 for the Conveyance Calculations and Analysis. The analysis, performed using Storm and Sanitary Sewer Analysis, shows that the proposed stormwater conveyance system has sufficient capacity to convey and contain the 25-year storm flow event of the fully developed project site. No proposed structures overtop and over 6-inches of freeboard is shown between the maximum hydraulic grade line and the proposed rim elevations of all proposed structures.

Refer to the Developed Conditions Map (Appendix A, Exhibit A-4) for the areas used to size the water quality basins, and Appendix D for the WWHM modeling used to determine the water quality flow rate.

4.0 Summary of Minimum Requirements

4.1 MR 1 – Preparation of Stormwater Site Plans

This report and the project plans represent the Stormwater Site Plan for this project and satisfy MR 1.

4.2 MR 2 - Construction Stormwater Pollution Prevention

A Construction Stormwater Pollution Prevention Plan (CSWPPP) will be completed and included as part of the construction documents.

4.3 MR 3 – Source Control of Pollution

The proposed project is required to provide source control of pollution. Following are proposed measures to be implemented as part of the civil plans.

- All discharges to the city storm system require City of Puyallup approval.
- All pollutants, including waste materials and demolition debris created onsite during construction, shall be handled and disposed of in a manner that does not cause contamination of surface water.
- Cover, containment, and protection from vandalism shall be provided for all chemicals, liquid products, petroleum products, and non-inert wastes present on the site (see Chapter 173-304 WAC for the definition of inert waste).
- Maintenance and repair of heavy equipment and vehicles that may result in discharge or spillage of pollutants to the ground or into surface water runoff must be conducted using spill prevention measures such as drip pans.

- Concrete Handling (BMP C151) and Sawcutting and Surfacing Pollution (BMP C152) shall be used to prevent or treat contamination of surface water runoff by pH modifying sources.

The CSWPPP provides details on the control of pollution during construction.

4.4 MR 4 – Preservation of Natural Drainage Systems and Outfalls

The existing discharge location shall be maintained under developed conditions. Under proposed conditions, treated runoff will be discharged to the same drain pipe which eventually discharges into the Puyallup river.

4.5 MR 5 – Onsite Stormwater Control

Existing trees and vegetation will be retained whenever possible. Trees and vegetation to be removed for building expansion and driveway relocation. Refer to the landscaping plans for additional information.

This project is using the list approach to meet Minimum Requirement #5 for onsite stormwater management. List #3 is to be used as this project is flow control exempt. For the roof area all three listed options are infeasible. Per the city of Puyallup, downspout controls are not applicable to this size of a non-residential project. Per the geotechnical report, the existing soils are not feasible for infiltration. The roof drains are to be directly connected to the onsite storm conveyance system for stormwater management.

For other hard surfaces BMPs flow dispersion is infeasible due to limited space for dispersion and lacking soil infiltration rates. In place of these BMPs stormwater flows onsite will be conveyed to several catch basins before being transported to a stormwater vault for treatment before being discharged into an existing storm main. BMP T5.13: Post-Construction Soil Quality and Depth will be utilized for disturbed lawn and landscaped areas.

All BMPs for the list approach for MR5 compliance for Roofs and Other Hard Surfaces were deemed infeasible. Site conditions were documented to conclude that each of these BMPs were infeasible: BMP T5.10A Downspout Full Infiltration, BMP T5.10B Downspout Dispersion Systems, BMP T5.10C Perforated Stub-Out Connections, BMP T5.11 Concentrated Flow Dispersion, and BMP T5.12 Sheet Flow Dispersion. This documentation demonstrated compliance with MR5.

One stormwater treatment vault is to be installed to meet basic treatment water quality standards for the parking lot. Refer to MR 6 for more information on the proposed runoff treatment facilities. Refer to MR 7 for a narrative describing how the project site is exempt from flow control requirements.

4.6 MR 6 – Runoff Treatment

Over 5,000 square feet of pollution-generating impervious surface (PGIS) will be added as part of these improvements; therefore, water quality treatment shall be provided. Per Appendix I-C of the *SMMWW* (III-A in *2019 SWMMWW*), the Puyallup River is a Basic Treatment Receiving Water at the location of the project site, below the Carbon River.

To meet basic water treatment the proposed site was lumped into one cumulative basin. Existing flows from pollution generating surfaces that were once treated by bioretention facilities are now to be directed to the new system for treatment and the device is sized accordingly. This basin will be conveyed into an Oldcastle biopod stormwater treatment vault. The parking lot is a total of 1.78 acres (Figure A-4). Other surfaces were included in this basin as their flows contribute to the conveyance system however water quality treatment of these other surfaces is not required. The

other surfaces include 0.83 acres of lawn, 0.15 acres of non-pollution generating impervious surface, and 1.45 acres of roof. Using WWHM water quality flow rates were calculated to be 0.2847 Cubic Feet per Second. The required Biopod to be sized is 8' by 16' treating up to 0.384 CFS. Refer to figure D-1 for WWHM report and figure D-2 for GULD approval and Biopod sizing.

4.7 MR 7 – Flow Control

The proposed stormwater system shall discharge runoff south to an existing municipal storm sewer manhole. The manhole discharges to the southeast through a 36" concrete pipe. This storm line outfalls into the Puyallup river. Per Appendix I-A table I-A.1 of the *SMMWW*, flow control is not required for runoff discharged, directly or indirectly, at least 0.5 mile downstream of the confluence with Kellogg Creek. The project site is significantly downstream of this confluence, and therefore flow control is not required for the project site.

4.8 MR 8 – Wetland Protection

No wetlands will be affected by the proposed development. Developed runoff is discharged through a closed conveyance system to an existing municipal piped storm sewer system that runs east and then south and discharges to the Puyallup River.

4.9 MR 9 – Operation and Maintenance

See Appendix C for a copy of the Operations and Maintenance Manual. This manual shall be readily available for inspection by the City of Puyallup. The maintenance and operations shall be the responsibility of the owner of the CPFDP project.

5.0 Construction Stormwater Pollution Prevention Plan

A Temporary Erosion Control Plan is included with the plan set, and a CSWPPP will be completed and included as part of the construction documents.

6.0 Special Reports and Studies

A geotechnical report was prepared by GeoEngineers, dated January 5, 2024. Refer to Appendix B.

According to FEMA FIRM the project site is located within Zone X (unshaded). Zone X (unshaded) are areas determined to be outside the 0.2% annual chance floodplain. However, the site is located within a seclusion zone boundary. A seclusion zone indicates that the current FEMA mapping is temporary and will be updated later. The seclusion zone is necessary since the area defined has not been proven to comply with Section 65.10 of the NFIP Regulations. See Appendix A, Exhibit A-6, for FEMA map and FEMA letter of map revision determination document.

7.0 Other Permits

At this time, no other permits are being applied for.

8.0 Operations and Maintenance Manual

Refer to Appendix C for the Maintenance Standards for the proposed drainage facilities and the Maintenance Checklist for the finished project site.

9.0 Conclusion

Based on our understanding and the attached documentation, we believe the proposed improvements conform to City of Puyallup and Washington State Department of Ecology standards. We conclude that this project, as proposed, will not have adverse impacts to the site or the downstream drainage system.

This analysis is based on data and records either supplied to or obtained by AHBL. These documents are referenced within the text of the analysis. The analysis has been prepared using procedures and practices within the standard accepted practices of the industry.

AHBL, Inc.

Zachary Perdue, EIT
Project Engineer

ZCP

February 2024

\\ahbl.com\data\Projects\2016\2230491\10_CIV\NON_CAD\REPORTS\SSP 20230705\20220705 Rpt (SSP) 2230491.10.docx

Appendix A

Exhibits

- A-1.....Vicinity Map
- A-2.....Existing Conditions Map
- A-3.....NRCS Soil Survey
- A-4.....Developed Conditions Map
- A-5.....Flow Chart for Determining Requirements for Redevelopment
- A-6.....FEMA Flood Map
- A-7.....Downstream As-Builts

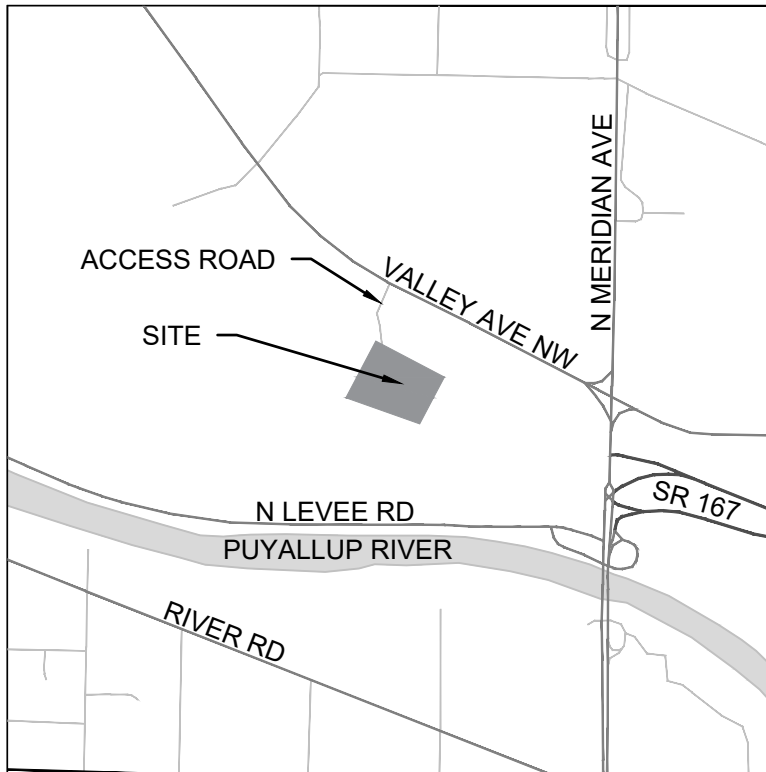

VICINITY MAP

1" = 1/4 MILE



2215 North 30th Street,
Suite 300,
Tacoma, WA 98403
253.383.2422 TEL
253.383.2572 FAX

VICINITY MAP
COASTAL PACIFIC FOOD DISTRIBUTIONS

JOB NO:
2230491.11
DATE: DATE

A-1

LEGEND

- △ SET NAIL AND WASHER
- FOUND PROPERTY CORNER
- BOLLARD
- ⊕ SIGN
- ⊙ UNKNOWN VAULT
- ⊕ GATE POST
- CLEANOUT
- ⊕ STORM CATCH BASIN
- ⊕ STORM MANHOLE
- ⊕ ROOF DRAIN
- ⊕ GAS METER
- ⊕ GAS VALVE
- ⊕ GENERATOR
- ⊕ JUNCTION BOX
- ⊕ POWER METER
- ⊕ LUMINAIRE
- ⊕ FIRE DEPARTMENT CONNECTION
- ⊕ FIRE HYDRANT
- ⊕ HOSE BIB
- ⊕ IRRIGATION CONTROL VALVE
- ⊕ CONFEROUS TREE AS NOTED
- ⊕ DECIDUOUS TREE AS NOTED
- D STORM LINE
- G GAS LINE
- E ELECTRICAL LINE
- T COMMUNICATION LINE
- F FENCE
- ASPHALT
- CONCRETE

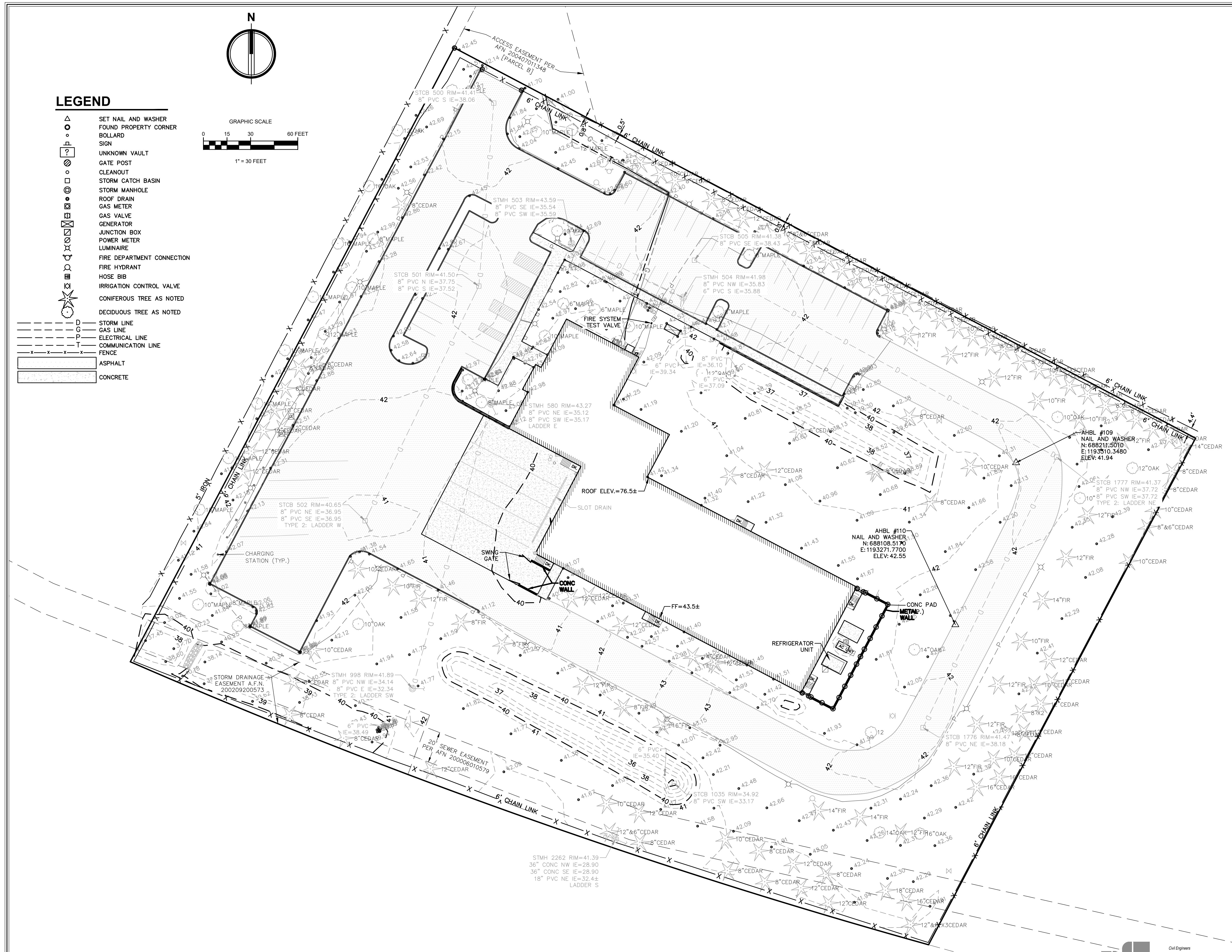
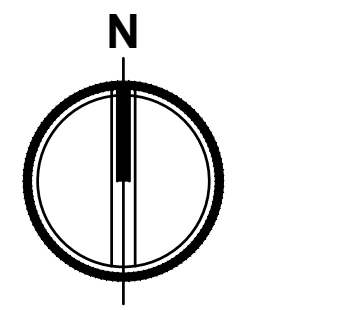

REFERENCE

CITY OF PUYALLUP BOUNDARY LINE REVISION NO. 04-84-003
AFN 200406025007 (BLA)

LEGAL DESCRIPTION

PARCEL 2 OF CITY OF PUYALLUP BOUNDARY LINE REVISION NO. 04-84-003
AFN 200406025007

VERTICAL DATUM

NAVD 1988 VERTICAL DATUM ON ORTHOMETRICALLY CORRECTED GPS
OBSERVATIONS USING WSRN AND GEOID 2012A.

BASIS OF BEARING

NAD 1983/11
WASHINGTON STATE PLANE SOUTH PROJECTION, BASED ON GPS
OBSERVATIONS USING WSRN AND GEOID 2012A. UNITS OF MEASUREMENT
ARE US SURVEY FEET.

UTILITY NOTES

1. SURFACE UTILITY FACILITIES ARE SHOWN HEREON PER FIELD LOCATED
VISIBLE EVIDENCE. THERE MAY BE UTILITIES THAT EXIST ON THIS SITE OTHER
THAN THOSE GRAPHICALLY DEPICTED HEREON.
2. UNDERGROUND (BURIED) UTILITIES SHOWN HEREON ARE BASED ON
COMBINATIONS OF VISIBLE SURFACE EVIDENCE, UTILITY LOCATOR MARKINGS
AND RECORD DATA (SUCH AS AS-BUILT OR UTILITY DESIGN DRAWINGS). ALL
UNDERGROUND UTILITIES SHOWN HEREON ARE APPROXIMATE AND, IN SOME
CASES, ARE SHOWN AS STRAIGHT LINES BETWEEN FIELD LOCATED SURFACE
UTILITY FACILITIES. UNDERGROUND UTILITIES MAY HAVE BENDS, CURVES OR
CONNECTIONS WHICH ARE NOT SHOWN.
3. ALTHOUGH LOCATIONS OF UNDERGROUND UTILITIES BASED ON UTILITY
LOCATOR MARKINGS AND RECORD DATA (SUCH AS AS-BUILT OR UTILITY
DESIGN DRAWINGS) ARE DEEMED RELIABLE, AHBL, INC. ASSUMES NO
LIABILITY FOR THE ACCURACY OF SAID DATA.
4. CALL 1-800-424-5555 BEFORE ANY CONSTRUCTION.

EQUIPMENT USED

3" TOTAL STATION UTILIZING STANDARD FIELD TRAVERSE METHODS FOR
CONTROL AND STAKING.

SURVEYOR'S CERTIFICATE

I, DAVID FOLLANSBEE, A PROFESSIONAL LAND SURVEYOR IN THE STATE OF
WASHINGTON, HEREBY CERTIFY THAT THIS MAP CORRECTLY REPRESENTS A
SURVEY MADE BY ME OR UNDER MY DIRECT SUPERVISION IN OCTOBER 2023
IN COMPLIANCE WITH THE REQUIREMENTS OF THE SURVEY RECORDING ACT,
CHAPTER 56.09 R.C.W. AND 332-130 W.A.C., AT THE REQUEST OF MATT
SMITH.



<p>EXISTING CONDITIONS MAP</p>	<p>A-2</p>
<p>COASTAL PACIFIC FOOD DISTIBUTIONS</p>	



United States
Department of
Agriculture

NRCS

Natural
Resources
Conservation
Service

A product of the National
Cooperative Soil Survey,
a joint effort of the United
States Department of
Agriculture and other
Federal agencies, State
agencies including the
Agricultural Experiment
Stations, and local
participants

Custom Soil Resource Report for Pierce County Area, Washington



Preface

Soil surveys contain information that affects land use planning in survey areas. They highlight soil limitations that affect various land uses and provide information about the properties of the soils in the survey areas. Soil surveys are designed for many different users, including farmers, ranchers, foresters, agronomists, urban planners, community officials, engineers, developers, builders, and home buyers. Also, conservationists, teachers, students, and specialists in recreation, waste disposal, and pollution control can use the surveys to help them understand, protect, or enhance the environment.

Various land use regulations of Federal, State, and local governments may impose special restrictions on land use or land treatment. Soil surveys identify soil properties that are used in making various land use or land treatment decisions. The information is intended to help the land users identify and reduce the effects of soil limitations on various land uses. The landowner or user is responsible for identifying and complying with existing laws and regulations.

Although soil survey information can be used for general farm, local, and wider area planning, onsite investigation is needed to supplement this information in some cases. Examples include soil quality assessments (<http://www.nrcs.usda.gov/wps/portal/nrcs/main/soils/health/>) and certain conservation and engineering applications. For more detailed information, contact your local USDA Service Center (<https://offices.sc.egov.usda.gov/locator/app?agency=nrcs>) or your NRCS State Soil Scientist (http://www.nrcs.usda.gov/wps/portal/nrcs/detail/soils/contactus/?cid=nrcs142p2_053951).

Great differences in soil properties can occur within short distances. Some soils are seasonally wet or subject to flooding. Some are too unstable to be used as a foundation for buildings or roads. Clayey or wet soils are poorly suited to use as septic tank absorption fields. A high water table makes a soil poorly suited to basements or underground installations.

The National Cooperative Soil Survey is a joint effort of the United States Department of Agriculture and other Federal agencies, State agencies including the Agricultural Experiment Stations, and local agencies. The Natural Resources Conservation Service (NRCS) has leadership for the Federal part of the National Cooperative Soil Survey.

Information about soils is updated periodically. Updated information is available through the NRCS Web Soil Survey, the site for official soil survey information.

The U.S. Department of Agriculture (USDA) prohibits discrimination in all its programs and activities on the basis of race, color, national origin, age, disability, and where applicable, sex, marital status, familial status, parental status, religion, sexual orientation, genetic information, political beliefs, reprisal, or because all or a part of an individual's income is derived from any public assistance program. (Not all prohibited bases apply to all programs.) Persons with disabilities who require

alternative means for communication of program information (Braille, large print, audiotape, etc.) should contact USDA's TARGET Center at (202) 720-2600 (voice and TDD). To file a complaint of discrimination, write to USDA, Director, Office of Civil Rights, 1400 Independence Avenue, S.W., Washington, D.C. 20250-9410 or call (800) 795-3272 (voice) or (202) 720-6382 (TDD). USDA is an equal opportunity provider and employer.

Contents

Preface	2
How Soil Surveys Are Made	5
Soil Map	8
Soil Map.....	9
Legend.....	10
Map Unit Legend.....	11
Map Unit Descriptions.....	11
Pierce County Area, Washington.....	13
31A—Puyallup fine sandy loam.....	13
42A—Sultan silt loam.....	14
References	16

How Soil Surveys Are Made

Soil surveys are made to provide information about the soils and miscellaneous areas in a specific area. They include a description of the soils and miscellaneous areas and their location on the landscape and tables that show soil properties and limitations affecting various uses. Soil scientists observed the steepness, length, and shape of the slopes; the general pattern of drainage; the kinds of crops and native plants; and the kinds of bedrock. They observed and described many soil profiles. A soil profile is the sequence of natural layers, or horizons, in a soil. The profile extends from the surface down into the unconsolidated material in which the soil formed or from the surface down to bedrock. The unconsolidated material is devoid of roots and other living organisms and has not been changed by other biological activity.

Currently, soils are mapped according to the boundaries of major land resource areas (MLRAs). MLRAs are geographically associated land resource units that share common characteristics related to physiography, geology, climate, water resources, soils, biological resources, and land uses (USDA, 2006). Soil survey areas typically consist of parts of one or more MLRA.

The soils and miscellaneous areas in a survey area occur in an orderly pattern that is related to the geology, landforms, relief, climate, and natural vegetation of the area. Each kind of soil and miscellaneous area is associated with a particular kind of landform or with a segment of the landform. By observing the soils and miscellaneous areas in the survey area and relating their position to specific segments of the landform, a soil scientist develops a concept, or model, of how they were formed. Thus, during mapping, this model enables the soil scientist to predict with a considerable degree of accuracy the kind of soil or miscellaneous area at a specific location on the landscape.

Commonly, individual soils on the landscape merge into one another as their characteristics gradually change. To construct an accurate soil map, however, soil scientists must determine the boundaries between the soils. They can observe only a limited number of soil profiles. Nevertheless, these observations, supplemented by an understanding of the soil-vegetation-landscape relationship, are sufficient to verify predictions of the kinds of soil in an area and to determine the boundaries.

Soil scientists recorded the characteristics of the soil profiles that they studied. They noted soil color, texture, size and shape of soil aggregates, kind and amount of rock fragments, distribution of plant roots, reaction, and other features that enable them to identify soils. After describing the soils in the survey area and determining their properties, the soil scientists assigned the soils to taxonomic classes (units). Taxonomic classes are concepts. Each taxonomic class has a set of soil characteristics with precisely defined limits. The classes are used as a basis for comparison to classify soils systematically. Soil taxonomy, the system of taxonomic classification used in the United States, is based mainly on the kind and character of soil properties and the arrangement of horizons within the profile. After the soil

Custom Soil Resource Report

scientists classified and named the soils in the survey area, they compared the individual soils with similar soils in the same taxonomic class in other areas so that they could confirm data and assemble additional data based on experience and research.

The objective of soil mapping is not to delineate pure map unit components; the objective is to separate the landscape into landforms or landform segments that have similar use and management requirements. Each map unit is defined by a unique combination of soil components and/or miscellaneous areas in predictable proportions. Some components may be highly contrasting to the other components of the map unit. The presence of minor components in a map unit in no way diminishes the usefulness or accuracy of the data. The delineation of such landforms and landform segments on the map provides sufficient information for the development of resource plans. If intensive use of small areas is planned, onsite investigation is needed to define and locate the soils and miscellaneous areas.

Soil scientists make many field observations in the process of producing a soil map. The frequency of observation is dependent upon several factors, including scale of mapping, intensity of mapping, design of map units, complexity of the landscape, and experience of the soil scientist. Observations are made to test and refine the soil-landscape model and predictions and to verify the classification of the soils at specific locations. Once the soil-landscape model is refined, a significantly smaller number of measurements of individual soil properties are made and recorded. These measurements may include field measurements, such as those for color, depth to bedrock, and texture, and laboratory measurements, such as those for content of sand, silt, clay, salt, and other components. Properties of each soil typically vary from one point to another across the landscape.

Observations for map unit components are aggregated to develop ranges of characteristics for the components. The aggregated values are presented. Direct measurements do not exist for every property presented for every map unit component. Values for some properties are estimated from combinations of other properties.

While a soil survey is in progress, samples of some of the soils in the area generally are collected for laboratory analyses and for engineering tests. Soil scientists interpret the data from these analyses and tests as well as the field-observed characteristics and the soil properties to determine the expected behavior of the soils under different uses. Interpretations for all of the soils are field tested through observation of the soils in different uses and under different levels of management. Some interpretations are modified to fit local conditions, and some new interpretations are developed to meet local needs. Data are assembled from other sources, such as research information, production records, and field experience of specialists. For example, data on crop yields under defined levels of management are assembled from farm records and from field or plot experiments on the same kinds of soil.

Predictions about soil behavior are based not only on soil properties but also on such variables as climate and biological activity. Soil conditions are predictable over long periods of time, but they are not predictable from year to year. For example, soil scientists can predict with a fairly high degree of accuracy that a given soil will have a high water table within certain depths in most years, but they cannot predict that a high water table will always be at a specific level in the soil on a specific date.

After soil scientists located and identified the significant natural bodies of soil in the survey area, they drew the boundaries of these bodies on aerial photographs and

Custom Soil Resource Report

identified each as a specific map unit. Aerial photographs show trees, buildings, fields, roads, and rivers, all of which help in locating boundaries accurately.

Soil Map

The soil map section includes the soil map for the defined area of interest, a list of soil map units on the map and extent of each map unit, and cartographic symbols displayed on the map. Also presented are various metadata about data used to produce the map, and a description of each soil map unit.

Custom Soil Resource Report Soil Map



Map Scale: 1:1,470 if printed on A landscape (11" x 8.5") sheet.

0 20 40 80 120 Meters

0 50 100 200 300 Feet

Map projection: Web Mercator Corner coordinates: WGS84 Edge tics: UTM Zone 10N WGS84

MAP LEGEND

Area of Interest (AOI)

 Area of Interest (AOI)



















Soils







 Soil Map Unit Polygons

 Soil Map Unit Lines

 Soil Map Unit Points

Special Point Features





-  Blowout
-  Borrow Pit
-  Clay Spot
-  Closed Depression
-  Gravel Pit
-  Gravelly Spot
-  Landfill
-  Lava Flow
-  Marsh or swamp
-  Mine or Quarry
-  Miscellaneous Water
-  Perennial Water
-  Rock Outcrop
-  Saline Spot
-  Sandy Spot
-  Severely Eroded Spot
-  Sinkhole
-  Slide or Slip
-  Sodic Spot

-  Spoil Area
-  Stony Spot
-  Very Stony Spot
-  Wet Spot
-  Other
-  Special Line Features

Water Features

 Streams and Canals

Transportation

-  Rails
-  Interstate Highways
-  US Routes
-  Major Roads
-  Local Roads

Background

 Aerial Photography

MAP INFORMATION

The soil surveys that comprise your AOI were mapped at 1:24,000.

Warning: Soil Map may not be valid at this scale.

Enlargement of maps beyond the scale of mapping can cause misunderstanding of the detail of mapping and accuracy of soil line placement. The maps do not show the small areas of contrasting soils that could have been shown at a more detailed scale.

Please rely on the bar scale on each map sheet for map measurements.

Source of Map: Natural Resources Conservation Service
 Web Soil Survey URL:
 Coordinate System: Web Mercator (EPSG:3857)

Maps from the Web Soil Survey are based on the Web Mercator projection, which preserves direction and shape but distorts distance and area. A projection that preserves area, such as the Albers equal-area conic projection, should be used if more accurate calculations of distance or area are required.

This product is generated from the USDA-NRCS certified data as of the version date(s) listed below.

Soil Survey Area: Pierce County Area, Washington
 Survey Area Data: Version 19, Aug 29, 2023

Soil map units are labeled (as space allows) for map scales 1:50,000 or larger.

Date(s) aerial images were photographed: Jul 31, 2022—Aug 8, 2022

The orthophoto or other base map on which the soil lines were compiled and digitized probably differs from the background imagery displayed on these maps. As a result, some minor shifting of map unit boundaries may be evident.

Map Unit Legend

Map Unit Symbol	Map Unit Name	Acres in AOI	Percent of AOI
31A	Puyallup fine sandy loam	3.8	72.8%
42A	Sultan silt loam	1.4	27.2%
Totals for Area of Interest		5.2	100.0%

Map Unit Descriptions

The map units delineated on the detailed soil maps in a soil survey represent the soils or miscellaneous areas in the survey area. The map unit descriptions, along with the maps, can be used to determine the composition and properties of a unit.

A map unit delineation on a soil map represents an area dominated by one or more major kinds of soil or miscellaneous areas. A map unit is identified and named according to the taxonomic classification of the dominant soils. Within a taxonomic class there are precisely defined limits for the properties of the soils. On the landscape, however, the soils are natural phenomena, and they have the characteristic variability of all natural phenomena. Thus, the range of some observed properties may extend beyond the limits defined for a taxonomic class. Areas of soils of a single taxonomic class rarely, if ever, can be mapped without including areas of other taxonomic classes. Consequently, every map unit is made up of the soils or miscellaneous areas for which it is named and some minor components that belong to taxonomic classes other than those of the major soils.

Most minor soils have properties similar to those of the dominant soil or soils in the map unit, and thus they do not affect use and management. These are called noncontrasting, or similar, components. They may or may not be mentioned in a particular map unit description. Other minor components, however, have properties and behavioral characteristics divergent enough to affect use or to require different management. These are called contrasting, or dissimilar, components. They generally are in small areas and could not be mapped separately because of the scale used. Some small areas of strongly contrasting soils or miscellaneous areas are identified by a special symbol on the maps. If included in the database for a given area, the contrasting minor components are identified in the map unit descriptions along with some characteristics of each. A few areas of minor components may not have been observed, and consequently they are not mentioned in the descriptions, especially where the pattern was so complex that it was impractical to make enough observations to identify all the soils and miscellaneous areas on the landscape.

The presence of minor components in a map unit in no way diminishes the usefulness or accuracy of the data. The objective of mapping is not to delineate pure taxonomic classes but rather to separate the landscape into landforms or landform segments that have similar use and management requirements. The delineation of such segments on the map provides sufficient information for the development of resource plans. If intensive use of small areas is planned, however,

Custom Soil Resource Report

onsite investigation is needed to define and locate the soils and miscellaneous areas.

An identifying symbol precedes the map unit name in the map unit descriptions. Each description includes general facts about the unit and gives important soil properties and qualities.

Soils that have profiles that are almost alike make up a *soil series*. Except for differences in texture of the surface layer, all the soils of a series have major horizons that are similar in composition, thickness, and arrangement.

Soils of one series can differ in texture of the surface layer, slope, stoniness, salinity, degree of erosion, and other characteristics that affect their use. On the basis of such differences, a soil series is divided into *soil phases*. Most of the areas shown on the detailed soil maps are phases of soil series. The name of a soil phase commonly indicates a feature that affects use or management. For example, Alpha silt loam, 0 to 2 percent slopes, is a phase of the Alpha series.

Some map units are made up of two or more major soils or miscellaneous areas. These map units are complexes, associations, or undifferentiated groups.

A *complex* consists of two or more soils or miscellaneous areas in such an intricate pattern or in such small areas that they cannot be shown separately on the maps. The pattern and proportion of the soils or miscellaneous areas are somewhat similar in all areas. Alpha-Beta complex, 0 to 6 percent slopes, is an example.

An *association* is made up of two or more geographically associated soils or miscellaneous areas that are shown as one unit on the maps. Because of present or anticipated uses of the map units in the survey area, it was not considered practical or necessary to map the soils or miscellaneous areas separately. The pattern and relative proportion of the soils or miscellaneous areas are somewhat similar. Alpha-Beta association, 0 to 2 percent slopes, is an example.

An *undifferentiated group* is made up of two or more soils or miscellaneous areas that could be mapped individually but are mapped as one unit because similar interpretations can be made for use and management. The pattern and proportion of the soils or miscellaneous areas in a mapped area are not uniform. An area can be made up of only one of the major soils or miscellaneous areas, or it can be made up of all of them. Alpha and Beta soils, 0 to 2 percent slopes, is an example.

Some surveys include *miscellaneous areas*. Such areas have little or no soil material and support little or no vegetation. Rock outcrop is an example.

Pierce County Area, Washington

31A—Puyallup fine sandy loam

Map Unit Setting

National map unit symbol: 2hq9
Elevation: 0 to 390 feet
Mean annual precipitation: 35 to 60 inches
Mean annual air temperature: 50 degrees F
Frost-free period: 170 to 200 days
Farmland classification: Prime farmland if irrigated

Map Unit Composition

Puyallup and similar soils: 85 percent
Minor components: 2 percent
Estimates are based on observations, descriptions, and transects of the mapunit.

Description of Puyallup

Setting

Landform: Terraces, flood plains
Parent material: Alluvium

Typical profile

H1 - 0 to 13 inches: ashy fine sandy loam
H2 - 13 to 29 inches: loamy fine sand
H3 - 29 to 60 inches: fine sand

Properties and qualities

Slope: 0 to 3 percent
Depth to restrictive feature: More than 80 inches
Drainage class: Well drained
Capacity of the most limiting layer to transmit water (Ksat): High (1.98 to 5.95 in/hr)
Depth to water table: About 48 to 79 inches
Frequency of flooding: NoneOccasional
Frequency of ponding: None
Available water supply, 0 to 60 inches: Moderate (about 6.6 inches)

Interpretive groups

Land capability classification (irrigated): 3w
Land capability classification (nonirrigated): 3w
Hydrologic Soil Group: A
Ecological site: F002XA008WA - Puget Lowlands Riparian Forest
Forage suitability group: Droughty Soils (G002XN402WA)
Other vegetative classification: Droughty Soils (G002XN402WA)
Hydric soil rating: No

Minor Components

Briscot, undrained

Percent of map unit: 2 percent
Landform: Depressions
Other vegetative classification: Seasonally Wet Soils (G002XN202WA)
Hydric soil rating: Yes

42A—Sultan silt loam

Map Unit Setting

National map unit symbol: 2hqx
Elevation: 0 to 200 feet
Mean annual precipitation: 35 to 55 inches
Mean annual air temperature: 50 degrees F
Frost-free period: 150 to 200 days
Farmland classification: All areas are prime farmland

Map Unit Composition

Sultan and similar soils: 85 percent
Minor components: 8 percent
Estimates are based on observations, descriptions, and transects of the mapunit.

Description of Sultan

Setting

Landform: Flood plains
Parent material: Alluvium

Typical profile

H1 - 0 to 14 inches: ashy silt loam
H2 - 14 to 23 inches: silt loam
H3 - 23 to 60 inches: stratified sand to silty clay loam

Properties and qualities

Slope: 0 to 2 percent
Depth to restrictive feature: More than 80 inches
Drainage class: Moderately well drained
Capacity of the most limiting layer to transmit water (Ksat): Moderately high (0.20 to 0.57 in/hr)
Depth to water table: About 18 to 24 inches
Frequency of flooding: NoneOccasional
Frequency of ponding: None
Available water supply, 0 to 60 inches: High (about 9.9 inches)

Interpretive groups

Land capability classification (irrigated): None specified
Land capability classification (nonirrigated): 3w
Hydrologic Soil Group: C/D
Ecological site: F002XA008WA - Puget Lowlands Riparian Forest
Forage suitability group: Seasonally Wet Soils (G002XN202WA)
Other vegetative classification: Seasonally Wet Soils (G002XN202WA)
Hydric soil rating: No

Minor Components

Briscot, undrained

Percent of map unit: 6 percent

Custom Soil Resource Report

Landform: Depressions

Other vegetative classification: Seasonally Wet Soils (G002XN202WA)

Hydric soil rating: Yes

Puget

Percent of map unit: 2 percent

Landform: Depressions

Other vegetative classification: Wet Soils (G002XN102WA)

Hydric soil rating: Yes

References

- American Association of State Highway and Transportation Officials (AASHTO). 2004. Standard specifications for transportation materials and methods of sampling and testing. 24th edition.
- American Society for Testing and Materials (ASTM). 2005. Standard classification of soils for engineering purposes. ASTM Standard D2487-00.
- Cowardin, L.M., V. Carter, F.C. Golet, and E.T. LaRoe. 1979. Classification of wetlands and deep-water habitats of the United States. U.S. Fish and Wildlife Service FWS/OBS-79/31.
- Federal Register. July 13, 1994. Changes in hydric soils of the United States.
- Federal Register. September 18, 2002. Hydric soils of the United States.
- Hurt, G.W., and L.M. Vasilas, editors. Version 6.0, 2006. Field indicators of hydric soils in the United States.
- National Research Council. 1995. Wetlands: Characteristics and boundaries.
- Soil Survey Division Staff. 1993. Soil survey manual. Soil Conservation Service. U.S. Department of Agriculture Handbook 18. http://www.nrcs.usda.gov/wps/portal/nrcs/detail/national/soils/?cid=nrcs142p2_054262
- Soil Survey Staff. 1999. Soil taxonomy: A basic system of soil classification for making and interpreting soil surveys. 2nd edition. Natural Resources Conservation Service, U.S. Department of Agriculture Handbook 436. http://www.nrcs.usda.gov/wps/portal/nrcs/detail/national/soils/?cid=nrcs142p2_053577
- Soil Survey Staff. 2010. Keys to soil taxonomy. 11th edition. U.S. Department of Agriculture, Natural Resources Conservation Service. http://www.nrcs.usda.gov/wps/portal/nrcs/detail/national/soils/?cid=nrcs142p2_053580
- Tiner, R.W., Jr. 1985. Wetlands of Delaware. U.S. Fish and Wildlife Service and Delaware Department of Natural Resources and Environmental Control, Wetlands Section.
- United States Army Corps of Engineers, Environmental Laboratory. 1987. Corps of Engineers wetlands delineation manual. Waterways Experiment Station Technical Report Y-87-1.
- United States Department of Agriculture, Natural Resources Conservation Service. National forestry manual. http://www.nrcs.usda.gov/wps/portal/nrcs/detail/soils/home/?cid=nrcs142p2_053374
- United States Department of Agriculture, Natural Resources Conservation Service. National range and pasture handbook. <http://www.nrcs.usda.gov/wps/portal/nrcs/detail/national/landuse/rangepasture/?cid=stelprdb1043084>



Custom Soil Resource Report

United States Department of Agriculture, Natural Resources Conservation Service. National soil survey handbook, title 430-VI. http://www.nrcs.usda.gov/wps/portal/nrcs/detail/soils/scientists/?cid=nrcs142p2_054242

United States Department of Agriculture, Natural Resources Conservation Service. 2006. Land resource regions and major land resource areas of the United States, the Caribbean, and the Pacific Basin. U.S. Department of Agriculture Handbook 296. http://www.nrcs.usda.gov/wps/portal/nrcs/detail/national/soils/?cid=nrcs142p2_053624

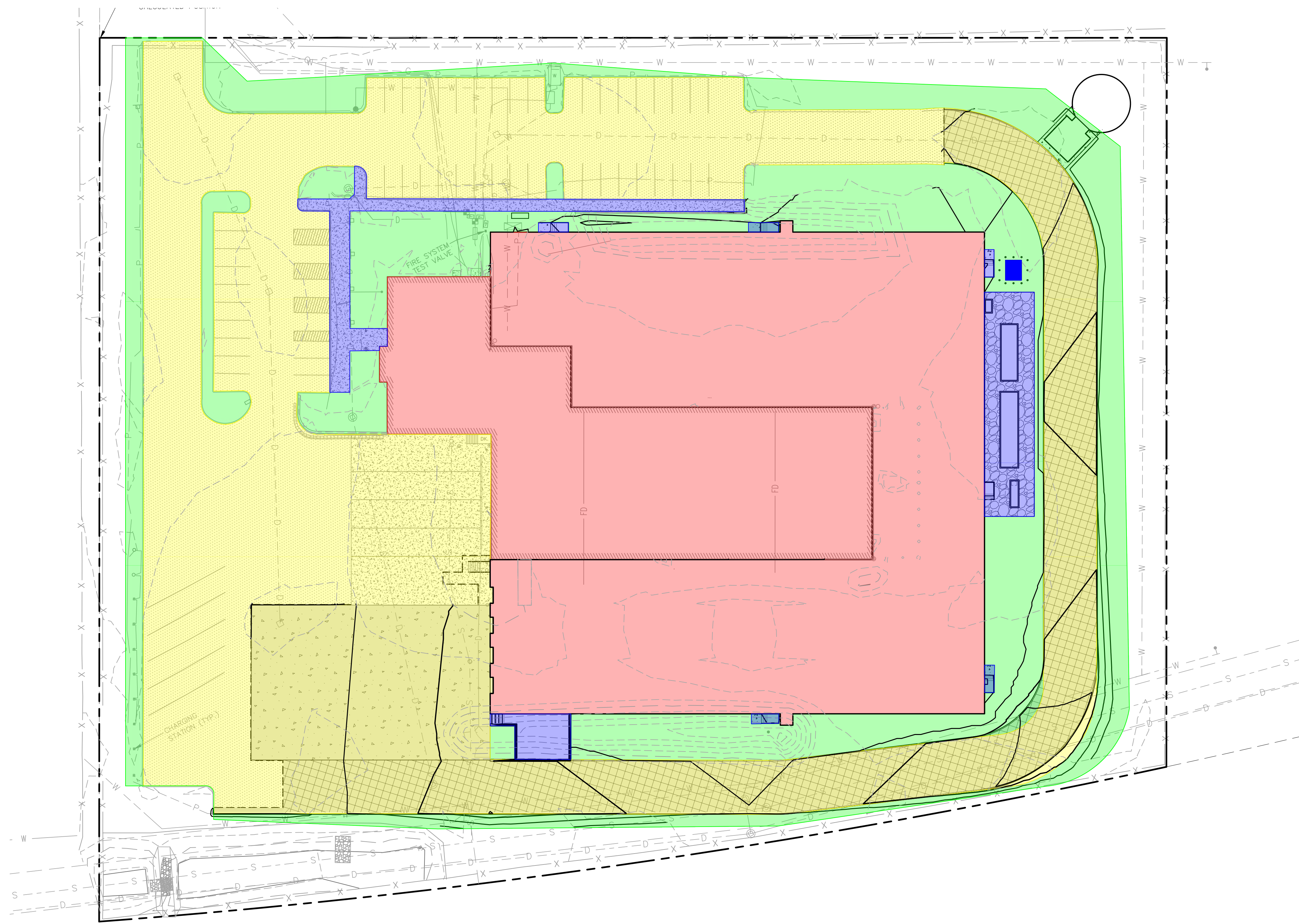
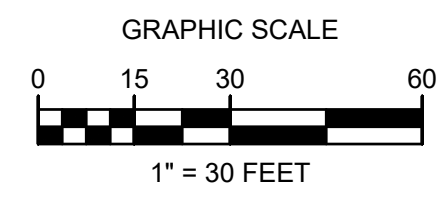
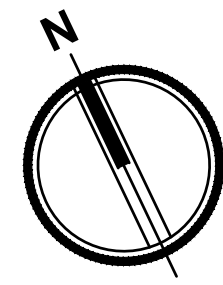
United States Department of Agriculture, Soil Conservation Service. 1961. Land capability classification. U.S. Department of Agriculture Handbook 210. http://www.nrcs.usda.gov/Internet/FSE_DOCUMENTS/nrcs142p2_052290.pdf

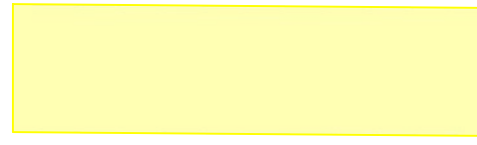

LAWN		0.83 ac
PARKING		1.78 ac
SIDEWALK		0.15 ac
ROOF		1.45 ac



Civil Engineers
Structural Engineers
Landscape Architects
Community Planners
Land Surveyors
Historians

PROPOSED CONDITIONS MAP	
COASTAL PACIFIC FOOD DISTRIBUTIONS	

Figure I-3.2: Flow Chart for Determining Requirements for Redevelopment

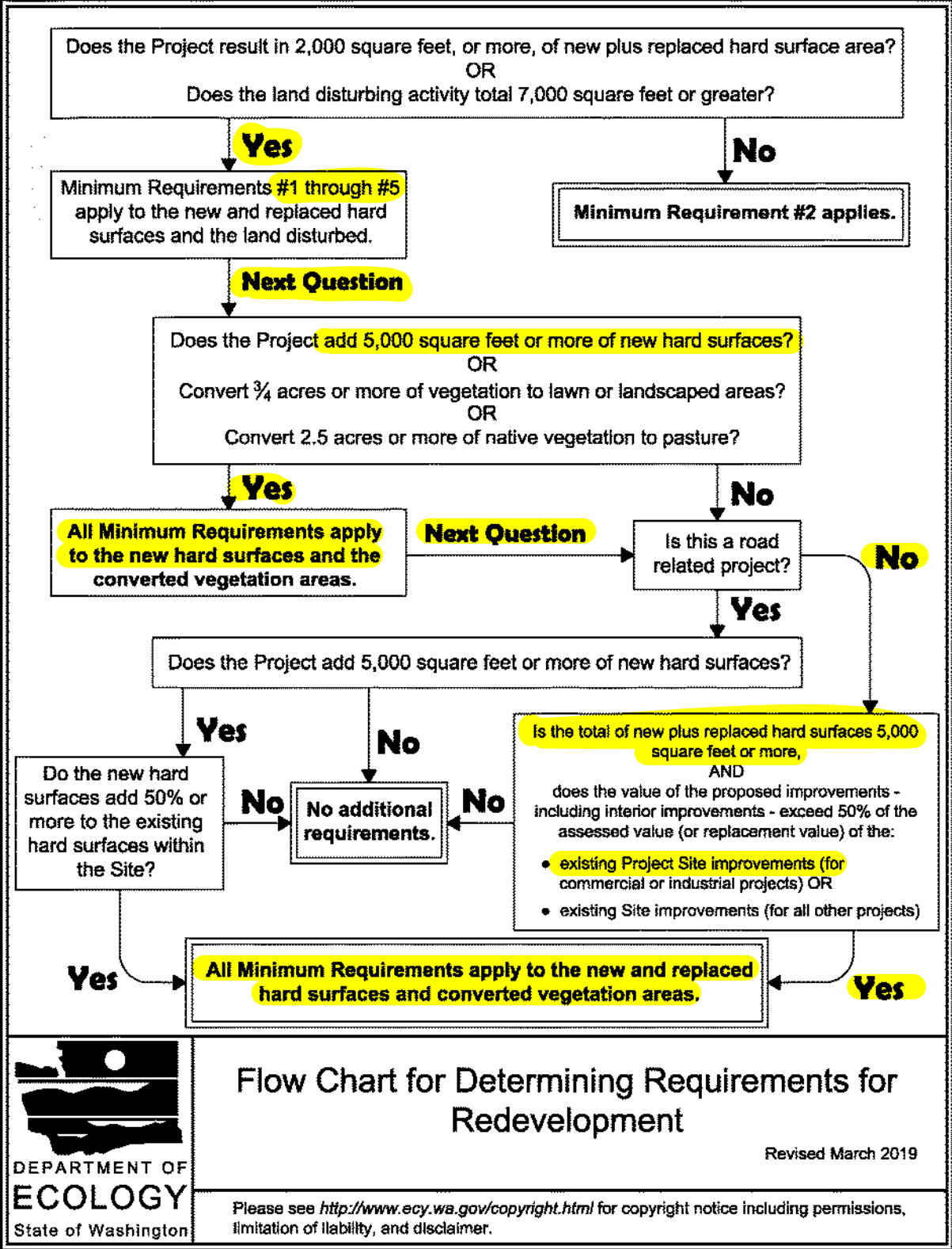

Flow Chart for Determining Requirements for Redevelopment

Revised March 2019

Please see <http://www.ecy.wa.gov/copyright.html> for copyright notice including permissions, limitation of liability, and disclaimer.

NOTES TO USERS

This map is for use in administering the National Flood Insurance Program. It does not necessarily identify all areas subject to flooding, particularly from local drainage sources of small size. The community map repository should be consulted for possible updated or additional flood hazard information.

To obtain more detailed information in areas where **Base Flood Elevations (BFEs)** and/or **floodways** have been determined, users are encouraged to consult the Flood Profiles and Floodway Data and/or Summary of Stillwater Elevations tables contained within the Flood Insurance Study (FIS) Report that accompanies this FIRM. Users should be aware that BFEs shown on the FIRM represent rounded whole-foot elevations. These BFEs are intended for flood insurance rating purposes only and should not be used as the sole source of flood elevation information. Accordingly, flood elevation data presented in the FIS Report should be utilized in conjunction with the FIRM for purposes of construction and/or floodplain management.

Coastal Base Flood Elevations shown on this map apply only landward of 0.0' North American Vertical Datum of 1988 (NAVD 88). Users of this FIRM should be aware that coastal flood elevations are also provided in the Summary of Stillwater Elevations table in the Flood Insurance Study Report for this jurisdiction. Elevations shown in the Summary of Stillwater Elevations table should be used for construction and/or floodplain management purposes when they are higher than the elevations shown on this FIRM.

Boundaries of the **floodways** were computed at cross sections and interpolated between cross sections. The floodways were based on hydraulic considerations with regard to requirements of the National Flood Insurance Program. Floodway widths and other pertinent floodway data are provided in the Flood Insurance Study Report for this jurisdiction.

Certain areas not in Special Flood Hazard Areas may be protected by **flood control structures**. Refer to Section 2.4 "Flood Protection Measures" of the Flood Insurance Study Report for information on flood control structures for this jurisdiction.

The **projection** used in the preparation of this map was Universal Transverse Mercator (UTM) zone 10. The horizontal datum was NAD 83, GRS 1980 spheroid. Differences in datum, spheroid, projection or UTM zones used in the production of FIRMs for adjacent jurisdictions may result in slight positional differences in map features across jurisdiction boundaries. These differences do not affect the accuracy of this FIRM.

Flood elevations on this map are referenced to the North American Vertical Datum of 1988. These flood elevations must be compared to structure and ground elevations referenced to the same vertical datum. For information regarding conversion between the National Geodetic Vertical Datum of 1929 and the North American Vertical Datum of 1988, visit the National Geodetic Survey website at <http://www.ngs.noaa.gov> or contact the National Geodetic Survey at the following address:

NGS Information Services
NOAA, NINGS12
National Geodetic Survey
SSMC-3, #9202
1315 East-West Highway
Silver Spring, Maryland 20910-3282
(301) 713-3242

To obtain current elevation, description, and/or location information for **bench marks** shown on this map, please contact the Information Services Branch of the National Geodetic Survey at (301) 713-3242, or visit its website at <http://www.ngs.noaa.gov>.

Base map information shown on this FIRM was derived from multiple sources. Base map files were provided in digital format by Pierce County GIS, WA DNR, WSDOT, USFWS, Washington State Department of Ecology, and Puget Sound Regional Council. This information was compiled at scales of 1:1,200 to 1:24,000 during the time period 1996-2012.

The **profile baselines** depicted on this map represent the hydraulic modeling baselines that match the flood profiles in the FIS report. As a result of improved topographic data, the **profile baseline**, in some cases, may deviate significantly from the channel centerline or appear outside the SFHA.

Corporate limits shown on this map are based on the best data available at the time of publication. Because changes due to annexations or de-annexations may have occurred after this map was published, map users should contact appropriate community officials to verify current corporate limit locations.

Please refer to the separately printed **Map Index** for an overview map of the county showing the layout of map panels, community map repository addresses, and a Listing of Communities table containing National Flood Insurance Program dates for each community as well as a listing of the panels on which each community is located.

For information on available products associated with this FIRM visit the **Map Service Center (MSC)** website at <http://msc.fema.gov>. Available products may include previously issued Letters of Map Change, a Flood Insurance Study Report, and/or digital versions of this map. Many of these products can be ordered or obtained directly from the MSC website.

If you have **questions about this map**, how to order products, or the National Flood Insurance Program in general, please call the **FEMA Map Information eXchange (FMIX)** at 1-877-FEMA-MAP (1-877-336-2627) or visit the FEMA website at <http://www.fema.gov/business/rfp>.

Tribal lands exist on this panel, but have not been shown. These areas are present in the DFIRM database in the S_Pol_Ar table.

ATTENTION: The levee, dike, or other structure that impacts flood hazards inside this boundary has not been shown to comply with Section 65.10 of the NFIP Regulations. As such, this FIRM panel will be revised at a later date to update the flood hazard information associated with this structure.

The flood hazard data inside this boundary on the FIRM panel has been republished from the previous effective (historic) FIRM for this area, after being converted from NGVD 29 to NAVD 88.

A-6

PIERCE COUNTY UNINCORPORATED AREAS 530138

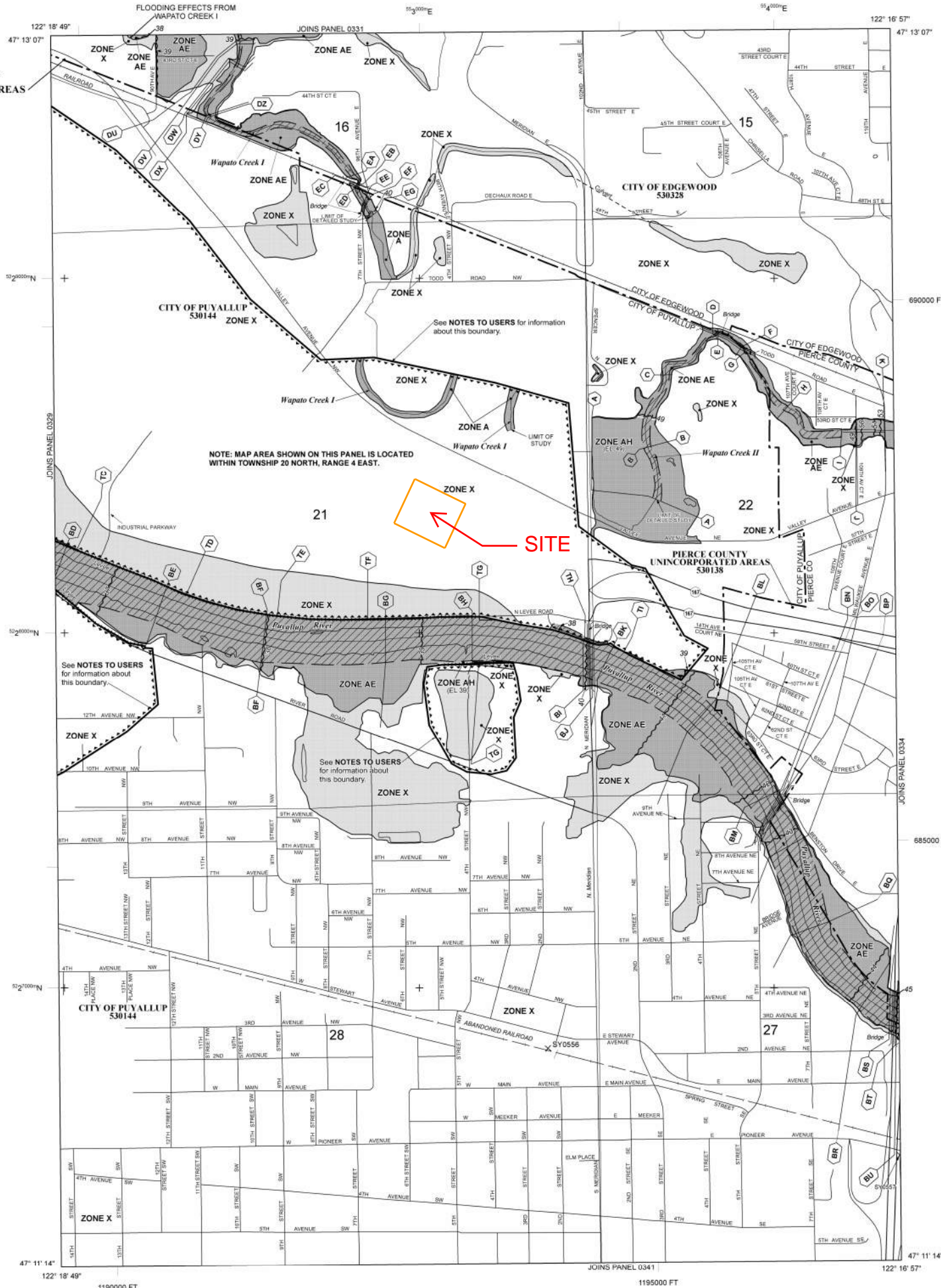

LEGEND

- SPECIAL FLOOD HAZARD AREAS (SFHAs) SUBJECT TO INUNDATION BY THE 1% ANNUAL CHANCE FLOOD. The 1% annual chance flood (100-year flood), also known as the base flood, is the flood that has a 1% chance of being equaled or exceeded in any given year. The Special Flood Hazard Area is the area subject to flooding by the 1% annual chance flood. Areas of Special Flood Hazard include Zones A, AE, AH, AO, AR, A99, V, and VE. The Base Flood Elevation is the water-surface elevation of the 1% annual chance flood.
- ZONE A** No Base Flood Elevations determined.
- ZONE AE** Base Flood Elevations determined.
- ZONE AH** Flood depths of 1 to 3 feet (usually areas of ponding); Base Flood Elevations determined.
- ZONE AO** Flood depths of 1 to 3 feet (usually sheet flow on sloping terrain); average depths determined. For areas of alluvial fan flooding, velocities also determined.
- ZONE AR** Special Flood Hazard Areas formerly protected from the 1% annual chance flood by a flood control system that was subsequently determined. Zone AR indicates that the former flood control system is being restored to provide protection from the 1% annual chance or greater flood.
- ZONE A99** Area to be protected from 1% annual chance flood by a Federal flood protection system under construction; no Base Flood Elevations determined.
- ZONE V** Coastal flood zone with velocity hazard (wave action); no Base Flood Elevations determined.
- ZONE VE** Coastal flood zone with velocity hazard (wave action); Base Flood Elevations determined.
- FLOODWAY AREAS IN ZONE AE. The floodway is the channel of a stream plus any adjacent floodplain areas that must be kept free of encroachment so that the 1% annual chance flood can be carried without substantial increases in flood heights.
- OTHER FLOOD AREAS**
- ZONE X** Areas of 0.2% annual chance flood; areas of 1% annual chance flood with average depths of less than 1 foot or with drainage areas less than 1 square mile; and areas protected by levees from 1% annual chance flood.
- OTHER AREAS**
- ZONE X** Areas determined to be outside the 0.2% annual chance floodplain.
- ZONE D** Areas in which flood hazards are undetermined, but possible.
- COASTAL BARRIER RESOURCES SYSTEM (CBRS) AREAS
- OTHERWISE PROTECTED AREAS (OPAs)
- CBRS areas and OPAs are normally located within or adjacent to Special Flood Hazard Areas.
- 1% Annual Chance Floodplain Boundary
- 0.2% Annual Chance Floodplain Boundary
- Floodway boundary
- Zone D boundary
- CBRS and OPA boundary
- Boundary dividing Special Flood Hazard Area Zones and boundary dividing Special Flood Hazard Areas of different Base Flood Elevations, flood depths, or flood velocities.
- Base Flood Elevation line and value; elevation in feet*
- Base Flood Elevation value where uniform within zone; elevation in feet*
- *Referenced to the North American Vertical Datum of 1988
- Cross section line
- Transect line
- Culvert
- Bridge
- 45° 02' 08", 93° 02' 12"
- Geographic coordinates referenced to the North American Datum of 1983 (NAD 83) Western Hemisphere
- 1000-meter Universal Transverse Mercator grid values, zone 10
- Bench mark (see explanation in Notes to Users section of this FIRM panel)
- Mile
- MAP REPOSITORIES**
Refer to Map Repositories list on Map Index
- EFFECTIVE DATE OF COUNTYWIDE FLOOD INSURANCE RATE MAP: March 7, 2017
- EFFECTIVE DATE(S) OF REVISION(S) TO THIS PANEL:
- For community map revision history prior to countywide mapping, refer to the Community Map History table located in the Flood Insurance Study report for this jurisdiction.
- To determine if flood insurance is available in this community, contact your insurance agent or call the National Flood Insurance Program at 1-800-438-6620.

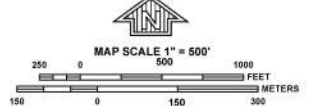

NATIONAL FLOOD INSURANCE PROGRAM

PANEL 0333E

FIRM
FLOOD INSURANCE RATE MAP
PIERCE COUNTY,
WASHINGTON
AND INCORPORATED AREAS

PANEL 333 OF 1375
(SEE MAP INDEX FOR FIRM PANEL LAYOUT)

CONTAINS:	COMMUNITY	NUMBER	PANEL	SUFFIX
	EDGEWOOD, CITY OF	53029	0333	E
	PIERCE COUNTY	530138	0333	E
	PUYALLUP, CITY OF	530144	0333	E

Notice to User: The **Map Number** shown below should be used when placing map orders. The **Community Number** shown above should be used on insurance applications for the subject community.

MAP NUMBER
53053C0333E

EFFECTIVE DATE
MARCH 7, 2017

Federal Emergency Management Agency

A-6



Federal Emergency Management Agency

Washington, D.C. 20472

LETTER OF MAP REVISION DETERMINATION DOCUMENT

COMMUNITY AND REVISION INFORMATION		PROJECT DESCRIPTION	BASIS OF REQUEST
COMMUNITY	City of Puyallup Pierce County Washington	NO PROJECT	UPDATE
	COMMUNITY NO.: 530144		
IDENTIFIER	LOMR & Seclusion Boundary Revision for the City of Puyallup in Pierce County Washington	APPROXIMATE LATITUDE & LONGITUDE: 47.209, -122.301 SOURCE: USGS QUADRANGLE DATUM: NAD 83	
ANNOTATED MAPPING ENCLOSURES		ANNOTATED STUDY ENCLOSURES	
TYPE: FIRM* NO.: 53053C0333E DATE: March 7, 2017		NO REVISION TO THE FLOOD INSURANCE STUDY REPORT	

Enclosures reflect changes to flooding sources affected by this revision.

* FIRM - Flood Insurance Rate Map

FLOODING SOURCE & REVISED REACH

Wapato Creek I - Centered at approximately 1,100 feet south of Todd Road NW and approximately 1,300 feet west of North Meridian Avenue

SUMMARY OF REVISIONS

Flooding Source	Effective Flooding	Revised Flooding	Increases	Decreases
Wapato Creek I	Zone A	Zone X (unshaded)	NONE	YES
	Zone X (unshaded)	Zone X (shaded)	YES	NONE

DETERMINATION

This document provides the determination from the Department of Homeland Security's Federal Emergency Management Agency (FEMA) regarding a request for a Letter of Map Revision (LOMR) for the area described above. Using the information submitted, we have determined that a revision to the flood hazards depicted in the Flood Insurance Study (FIS) report and/or National Flood Insurance Program (NFIP) map is warranted. This document revises the effective NFIP map, as indicated in the attached documentation. Please use the enclosed annotated map panels revised by this LOMR for floodplain management purposes and for all flood insurance policies and renewals in your community.

This determination is based on the flood data presently available. The enclosed documents provide additional information regarding this determination. If you have any questions about this document, please contact the FEMA Map Information eXchange toll free at 1-877-336-2627 (1-877-FEMA MAP) or by letter addressed to the LOMC Clearinghouse, 3601 Eisenhower Avenue, Suite 500, Alexandria, VA 22304-6426. Additional Information about the NFIP is available on our website at <http://www.fema.gov/nfip>.

Patrick "Rick" F. Sacbbit, P.E., Branch Chief
Engineering Services Branch
Federal Insurance and Mitigation Administration



Federal Emergency Management Agency

Washington, D.C. 20472

LETTER OF MAP REVISION DETERMINATION DOCUMENT (CONTINUED)

COMMUNITY INFORMATION

APPLICABLE NFIP REGULATIONS/COMMUNITY OBLIGATION

We have made this determination pursuant to Section 206 of the Flood Disaster Protection Act of 1973 (P.L. 93-234) and in accordance with the National Flood Insurance Act of 1968, as amended (Title XIII of the Housing and Urban Development Act of 1968, P.L. 90-448), 42 U.S.C. 4001-4128, and 44 CFR Part 65. Pursuant to Section 1361 of the National Flood Insurance Act of 1968, as amended, communities participating in the NFIP are required to adopt and enforce floodplain management regulations that meet or exceed NFIP criteria. These criteria, including adoption of the FIS report and FIRM, and the modifications made by this LOMR, are the minimum requirements for continued NFIP participation and do not supersede more stringent State/Commonwealth or local requirements to which the regulations apply.

COMMUNITY REMINDERS

We based this determination on the 1-percent-annual-chance flood discharges computed in the FIS for your community without considering subsequent changes in watershed characteristics that could increase flood discharges. Future development of projects upstream could cause increased flood discharges, which could cause increased flood hazards. A comprehensive restudy of your community's flood hazards would consider the cumulative effects of development on flood discharges subsequent to the publication of the FIS report for your community and could, therefore, establish greater flood hazards in this area.

Your community must regulate all proposed floodplain development and ensure that permits required by Federal and/or State/Commonwealth law have been obtained. State/Commonwealth or community officials, based on knowledge of local conditions and in the interest of safety, may set higher standards for construction or may limit development in floodplain areas. If your State/Commonwealth or community has adopted more restrictive or comprehensive floodplain management criteria, those criteria take precedence over the minimum NFIP requirements.

We will not print and distribute this LOMR to primary users, such as local insurance agents or mortgage lenders; instead, the community will serve as a repository for the new data. We encourage you to disseminate the information in this LOMR by preparing a news release for publication in your community's newspaper that describes the revision and explains how your community will provide the data and help interpret the NFIP maps. In that way, interested persons, such as property owners, insurance agents, and mortgage lenders, can benefit from the information.

This determination is based on the flood data presently available. The enclosed documents provide additional information regarding this determination. If you have any questions about this document, please contact the FEMA Map Information eXchange toll free at 1-877-336-2627 (1-877-FEMA MAP) or by letter addressed to the LOMC Clearinghouse, 3601 Eisenhower Avenue, Suite 500, Alexandria, VA 22304-6426. Additional Information about the NFIP is available on our website at <http://www.fema.gov/nfip>.

A handwritten signature in black ink, appearing to read "Rick Sacbibit".

Patrick "Rick" F. Sacbibit, P.E., Branch Chief
Engineering Services Branch
Federal Insurance and Mitigation Administration



Federal Emergency Management Agency

Washington, D.C. 20472

LETTER OF MAP REVISION DETERMINATION DOCUMENT (CONTINUED)

We have designated a Consultation Coordination Officer (CCO) to assist your community. The CCO will be the primary liaison between your community and FEMA. For information regarding your CCO, please contact:

Mr. Mark Carey
Director, Mitigation Division
Federal Emergency Management Agency, Region X
Federal Regional Center
130 228th Street, Southwest
Bothell, WA 98021-8627
(425) 487-4682

STATUS OF THE COMMUNITY NFIP MAPS

We will not physically revise and republish the FIRM and FIS report for your community to reflect the modifications made by this LOMR at this time. When changes to the previously cited FIRM panel(s) and FIS report warrant physical revision and republication in the future, we will incorporate the modifications made by this LOMR at that time.

This determination is based on the flood data presently available. The enclosed documents provide additional information regarding this determination. If you have any questions about this document, please contact the FEMA Map Information eXchange toll free at 1-877-336-2627 (1-877-FEMA MAP) or by letter addressed to the LOMC Clearinghouse, 3601 Eisenhower Avenue, Suite 500, Alexandria, VA 22304-6426. Additional Information about the NFIP is available on our website at <http://www.fema.gov/nfip>.

A handwritten signature in black ink, appearing to read "Rick Sacbbit".

Patrick "Rick" F. Sacbbit, P.E., Branch Chief
Engineering Services Branch
Federal Insurance and Mitigation Administration



Federal Emergency Management Agency

Washington, D.C. 20472

LETTER OF MAP REVISION DETERMINATION DOCUMENT (CONTINUED)

PUBLIC NOTIFICATION OF REVISION

A notice of changes will be published in the *Federal Register*. This information also will be published in your local newspaper on or about the dates listed below, and through FEMA's Flood Hazard Mapping website at

https://www.floodmaps.fema.gov/fhm/bfe_status/bfe_main.asp

LOCAL NEWSPAPER

Name: *The News Tribune*

Dates: February 21, 2019 and February 28, 2019

Within 90 days of the second publication in the local newspaper, any interested party may request that we reconsider this determination. Any request for reconsideration must be based on scientific or technical data. Therefore, this letter will be effective only after the 90-day appeal period has elapsed and we have resolved any appeals that we receive during this appeal period. Until this LOMR is effective, the revised flood hazard determination presented in this LOMR may be changed.

This determination is based on the flood data presently available. The enclosed documents provide additional information regarding this determination. If you have any questions about this document, please contact the FEMA Map Information eXchange toll free at 1-877-336-2627 (1-877-FEMA MAP) or by letter addressed to the LOMC Clearinghouse, 3601 Eisenhower Avenue, Suite 500, Alexandria, VA 22304-6426. Additional Information about the NFIP is available on our website at <http://www.fema.gov/nfip>.

A handwritten signature in black ink, appearing to read "Rick F. Sacbbit".

Patrick "Rick" F. Sacbbit, P.E., Branch Chief
Engineering Services Branch
Federal Insurance and Mitigation Administration

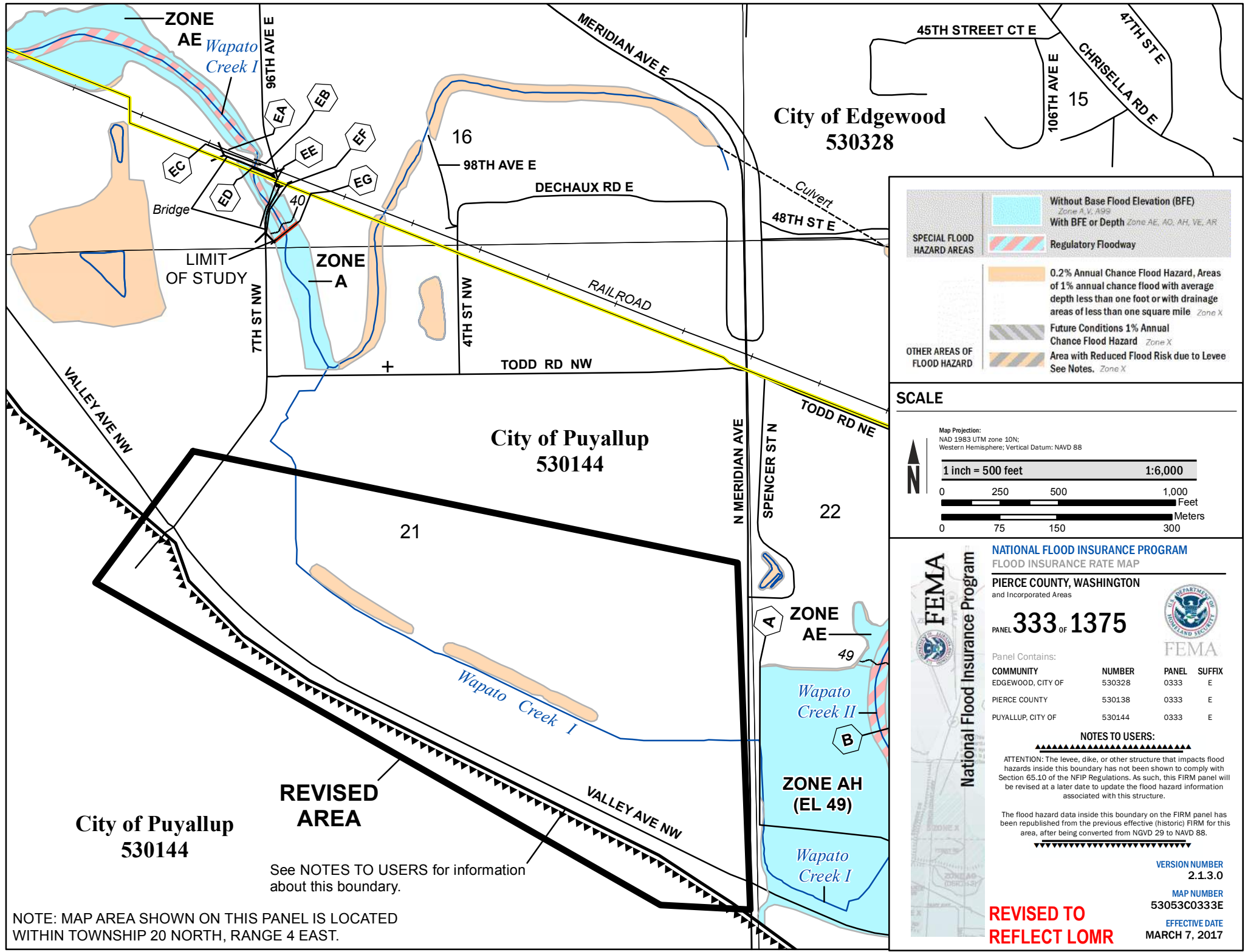

City of Edgewood
530328

City of Puyallup
530144

City of Puyallup
530144

See NOTES TO USERS for information about this boundary.

NOTE: MAP AREA SHOWN ON THIS PANEL IS LOCATED WITHIN TOWNSHIP 20 NORTH, RANGE 4 EAST.

SPECIAL FLOOD HAZARD AREAS

- Without Base Flood Elevation (BFE) Zone A, V, A99
- With BFE or Depth Zone AE, AO, AH, VE, AR
- Regulatory Floodway

OTHER AREAS OF FLOOD HAZARD

- 0.2% Annual Chance Flood Hazard, Areas of 1% annual chance flood with average depth less than one foot or with drainage areas of less than one square mile Zone X
- Future Conditions 1% Annual Chance Flood Hazard Zone X
- Area with Reduced Flood Risk due to Levee See Notes, Zone X

SCALE

Map Projection:
NAD 1983 UTM zone 10N;
Western Hemisphere; Vertical Datum: NAVD 88

1 inch = 500 feet 1:6,000

0 250 500 1,000 Feet
0 75 150 300 Meters

FEMA
National Flood Insurance Program

**NATIONAL FLOOD INSURANCE PROGRAM
FLOOD INSURANCE RATE MAP**

PIERCE COUNTY, WASHINGTON
and Incorporated Areas

PANEL **333.1375** OF 1375

COMMUNITY	NUMBER	PANEL	SUFFIX
EDGEWOOD, CITY OF	530328	0333	E
PIERCE COUNTY	530138	0333	E
PUYALLUP, CITY OF	530144	0333	E

NOTES TO USERS:

ATTENTION: The levee, dike, or other structure that impacts flood hazards inside this boundary has not been shown to comply with Section 65.10 of the NFIP Regulations. As such, this FIRM panel will be revised at a later date to update the flood hazard information associated with this structure.

The flood hazard data inside this boundary on the FIRM panel has been republished from the previous effective (historic) FIRM for this area, after being converted from NGVD 29 to NAVD 88.

VERSION NUMBER
2.1.3.0

MAP NUMBER
53053C0333E

EFFECTIVE DATE
MARCH 7, 2017

**REVISED TO
REFLECT LOMR
EFFECTIVE: June 28, 2019**

SCHWAN'S FOOD DISTRIBUTION CENTER

APPROVED

BY: CITY OF PUYALLUP
ENGINEERING DEPARTMENT

DATE: _____

NOTE:
THIS APPROVAL IS VOID AFTER
1 YEAR FROM APPROVAL DATE.
THE CITY WILL NOT BE RESPONSIBLE
FOR ERRORS AND/OR OMISSIONS
ON THESE PLANS.
FIELD CHANGES TO THESE PLANS AS
DETERMINED BY THE CITY ENGINEER.

Civil Engineers
Structural Engineers
Landscape Architects
Community Planners
Land Surveyors
Neighbors

AHBL

TACOMA • SEATTLE
2215 North 30th Street, Suite 300, Tacoma, WA 98403
253.383.2422 TEL.
318 Occidental Avenue South, Suite 320, Seattle, WA 98104
206.287.2425 TEL.

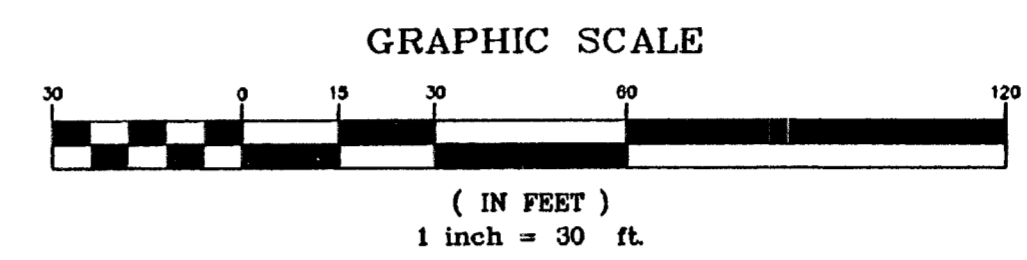

Project Title:
SCHWAN'S FOOD DISTRIBUTION CENTER
Record Drawings

Client:
SCHWAN'S SALES ENT., INC.
SCHWAN'S FOOD SERVICE
115 W. COLLEGE DRIVE
MARSHALL, MN 56258-1747
MR. JOE HENN
(507) 532-9523 EXT. 8274

Job No.
203641.10

Issue Set & Date:
PERMIT SET
09/07/05

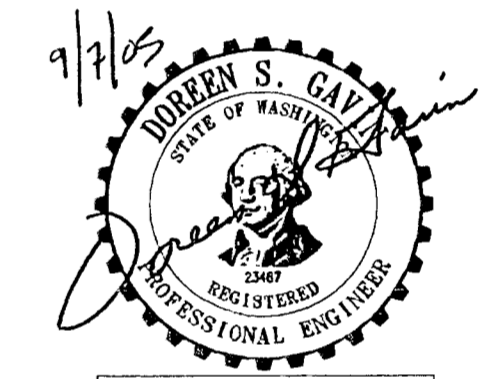

REUSE OF DOCUMENTS
THIS DOCUMENT HAS BEEN REUSED ELECTRONICALLY IN ACCORDANCE WITH THE 2003-2006 ENGINEERING BOARD UNAUTHORIZED REPRODUCTION OR USE OF THIS INFORMATION IN ANY MANNER WITHOUT THE WRITTEN PERMISSION OF THE ENGINEER IS PROHIBITED AND PENALIZED.
BY CONTRACTOR AND OWNER:
THE USER OF THIS DOCUMENT ASSUMES ALL LIABILITY FOR ANY AND ALL USE OF THIS DOCUMENT, IN WHOLE OR IN PART, FOR ANY PURPOSE NOT INTENDED BY THE ENGINEER OR OWNER.

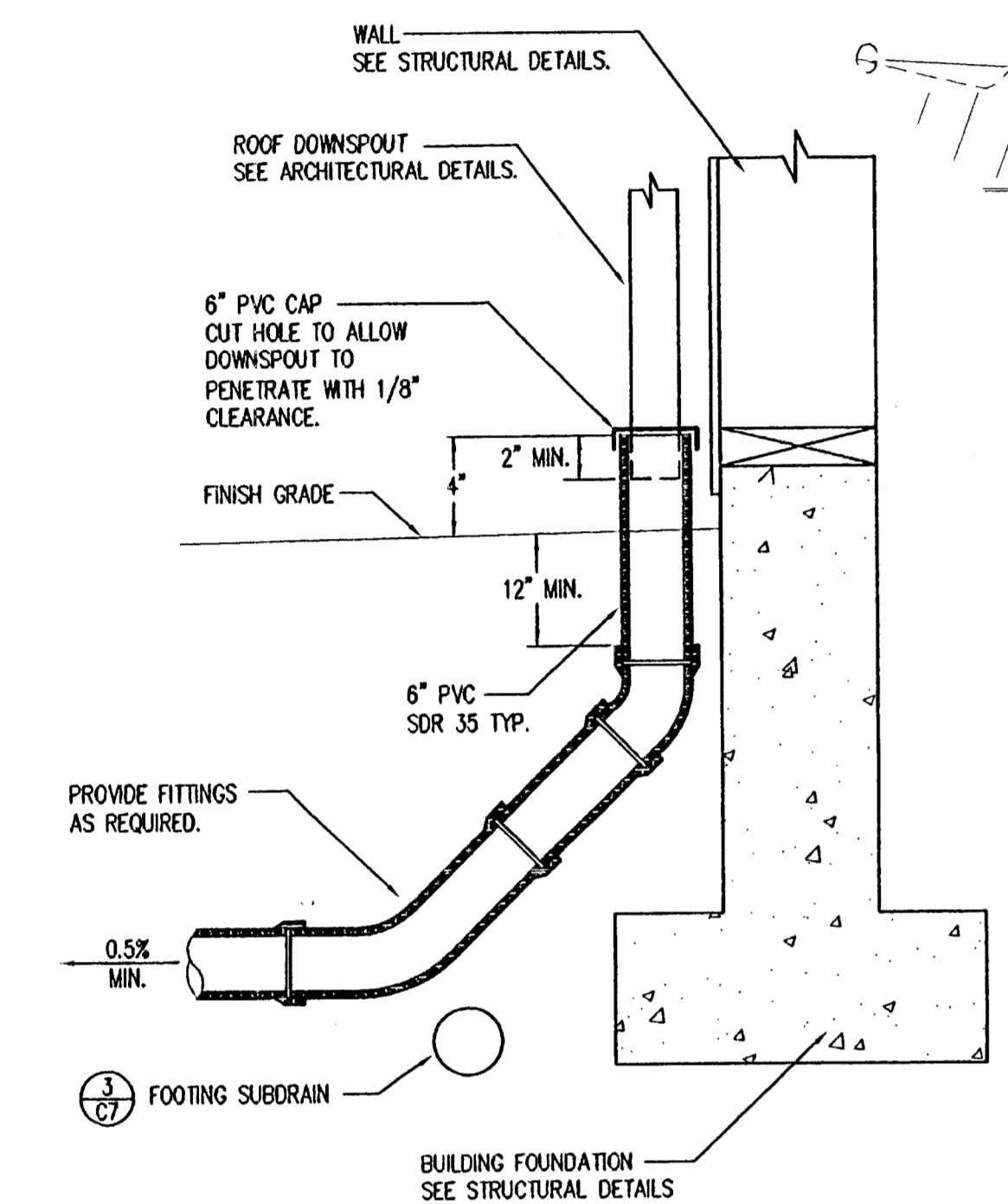

1 ROOF DOWNSPOUT CONNECTION
NOT TO SCALE

GENERAL NOTES

- CONTRACTOR SHALL FIELD VERIFY CONDITIONS AND IMMEDIATELY CONTACT THE ENGINEER IF PROPOSED IMPROVEMENTS CANNOT BE PROVIDED.
- PROVIDE CATCH BASIN STENCIL ADJACENT TO ALL CATCH BASINS WITHIN PAVEMENT AREAS PER DETAIL.
- ROOF DRAIN SYSTEM IS SHOWN FOR SCHEMATIC PURPOSES. ALL ROOF DRAIN PIPES SHALL BE 6-INCH DIAMETER WITH A MINIMUM SLOPE OF 0.50% UNLESS OTHERWISE INDICATED. SEE ARCHITECT PLANS FOR EXACT LOCATION AND NUMBER OF DOWNSPOUTS. NO OFFSETS ALLOWED.
- PROVIDE FOOTING DRAIN AT PERIMETER OF BUILDING PER DETAIL. CONNECT FOOTING DRAIN TO ADJACENT CATCH BASIN.
- AN ADDITIONAL FOOTING DRAIN SHALL BE PROVIDED UNDER THE WAREHOUSE PORTION OF THE BUILDING, SINCE THIS PART OF THE BUILDING WILL BE A FREEZER (LABELED AS 'FD').
- PROVIDE SIX-INCH VERTICAL AND THREE-FOOT HORIZONTAL CLEARANCE (OUTSIDE SURFACES) BETWEEN STORM DRAIN LINES AND OTHER UTILITY PIPE AND CONDUITS PROVIDED.
- PROVIDE BEDDING & BACKFILL IN TRENCHES PER DETAIL.
- MINIMUM DISTANCE BETWEEN SEWER AND WATER LINES SHALL BE 10FT HORIZONTAL & 1FT VERTICALLY.
- THE AREA UNDER THE WAREHOUSE PORTION OF THE BUILDING SHALL BE EXCAVATED TO ALLOW FOR FOUR FEET OF RIVER RUN ROCK TO BE PLACED BELOW THE FLOOR SLAB.
- ALL STORM PIPE SHALL BE ADS N-12 UNLESS OTHERWISE NOTED. SEE CITY'S STANDARD STORM WATER NOTES SHEET C7.
- CONTRACTOR SHALL PROVIDE TW AND BW ELEVATIONS FOR RETAINING WALLS. ALL RETAINING WALLS 4' AND HIGHER REQUIRE SEPERATE BUILDING PERMITS.
- SEE STORMWATER NOTES ON SHEET C7.

CALL 48 HOURS BEFORE YOU DIG
1-800-424-5555

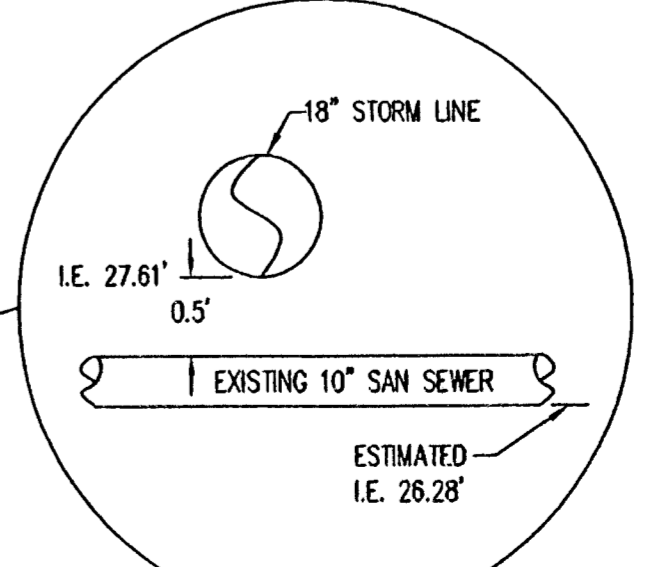
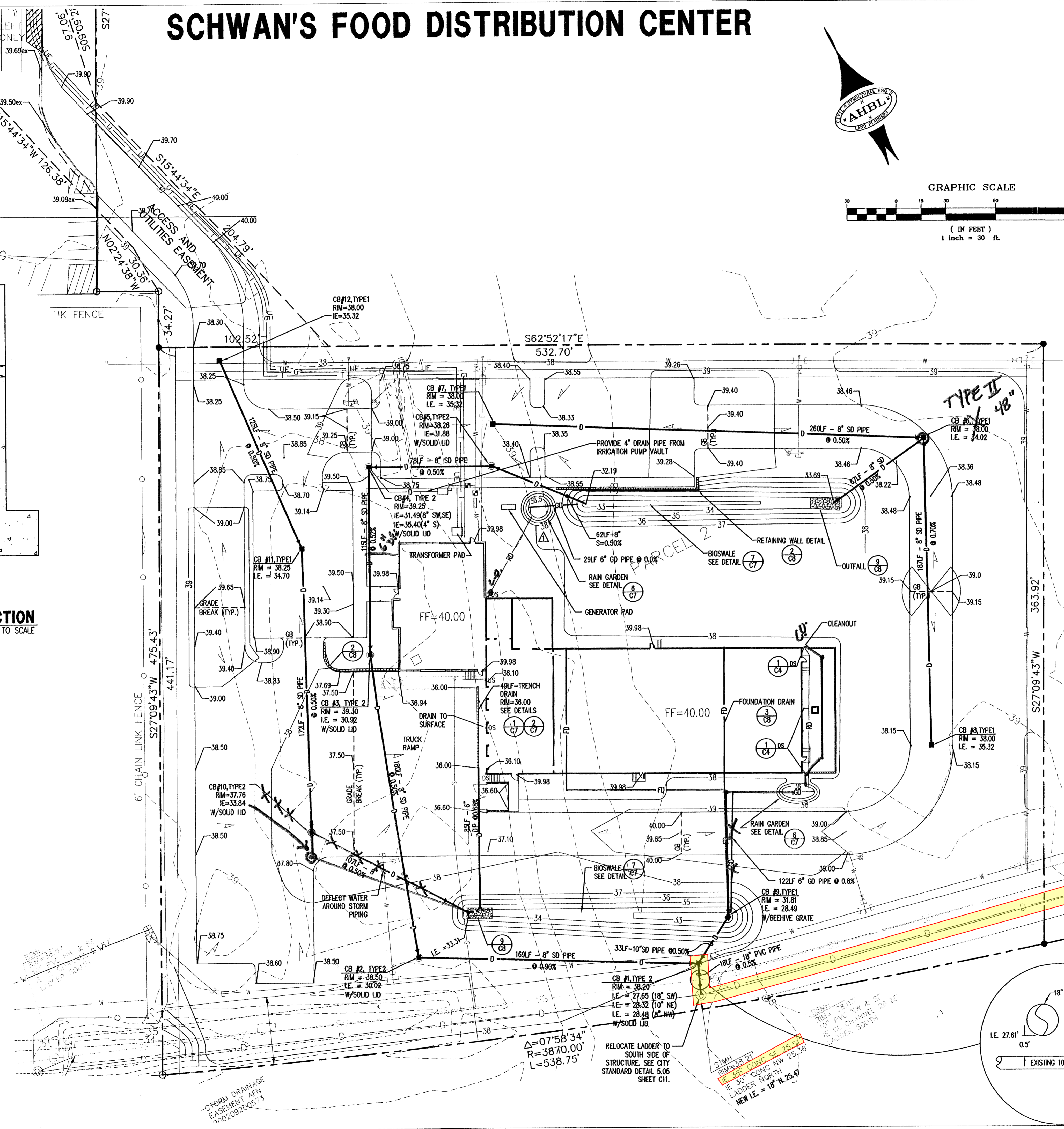

- △ Addendum 5 (11-19-05)
- Revisions:
- Sheet Title:
GRADING & DRAINAGE PLAN
- Designed by: _____ Drawn by: CTH Checked by: _____
- Sheet No.
C4

DRAWING NUMBER

SCHWAN'S FOOD DISTRIBUTION CENTER RECORD DRAWINGS GRADING AND DRAINAGE PLAN

DRAWING NUMBER

DRAWING NUMBER

81

SERTA MATTRESS COMPANY

GRADING AND T.E.S.C. PLAN

A PORTION OF SECTION 22, TOWNSHIP 20 NORTH, RANGE 4 EAST,
WILLAMETTE MERIDIAN, CITY OF PUYALLUP, WASHINGTON.

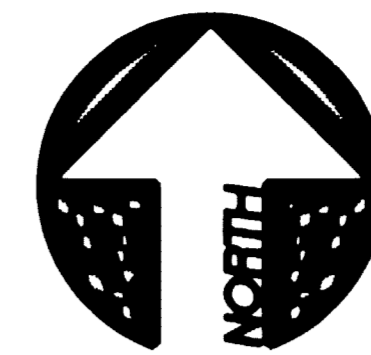

GRAPHIC SCALE

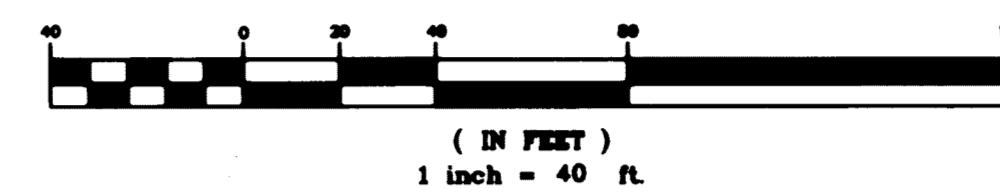

APPROVED
By *[Signature]*
CITY OF PUYALLUP
ENGINEERING DEPARTMENT
DATE *Dec 5, 1994*

NOTE:
This approval is void after 1 year from approval date. The City will not be responsible for errors and/or omissions on these plans.
Field conditions may dictate changes to these plans as determined by the City Engineer.

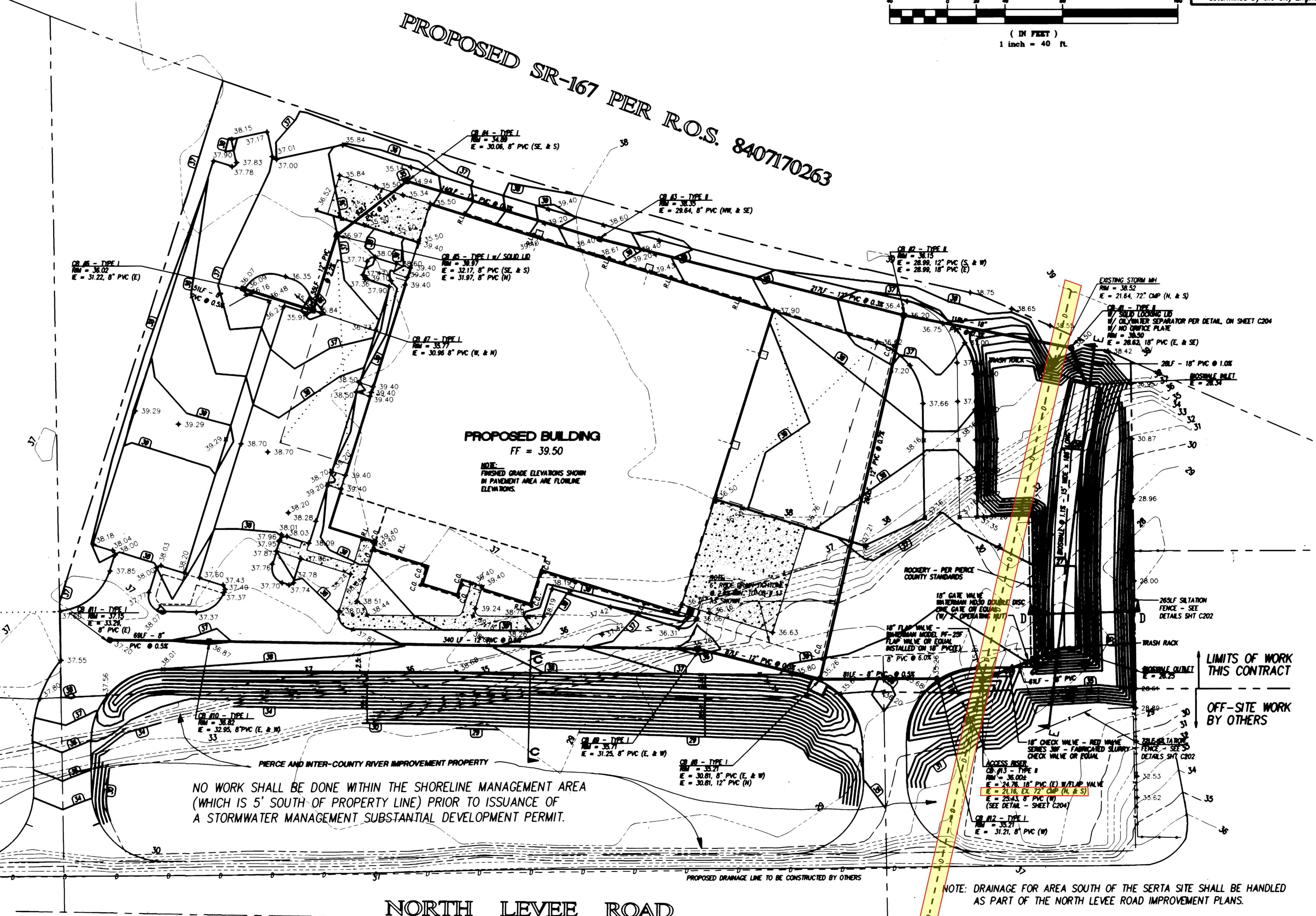
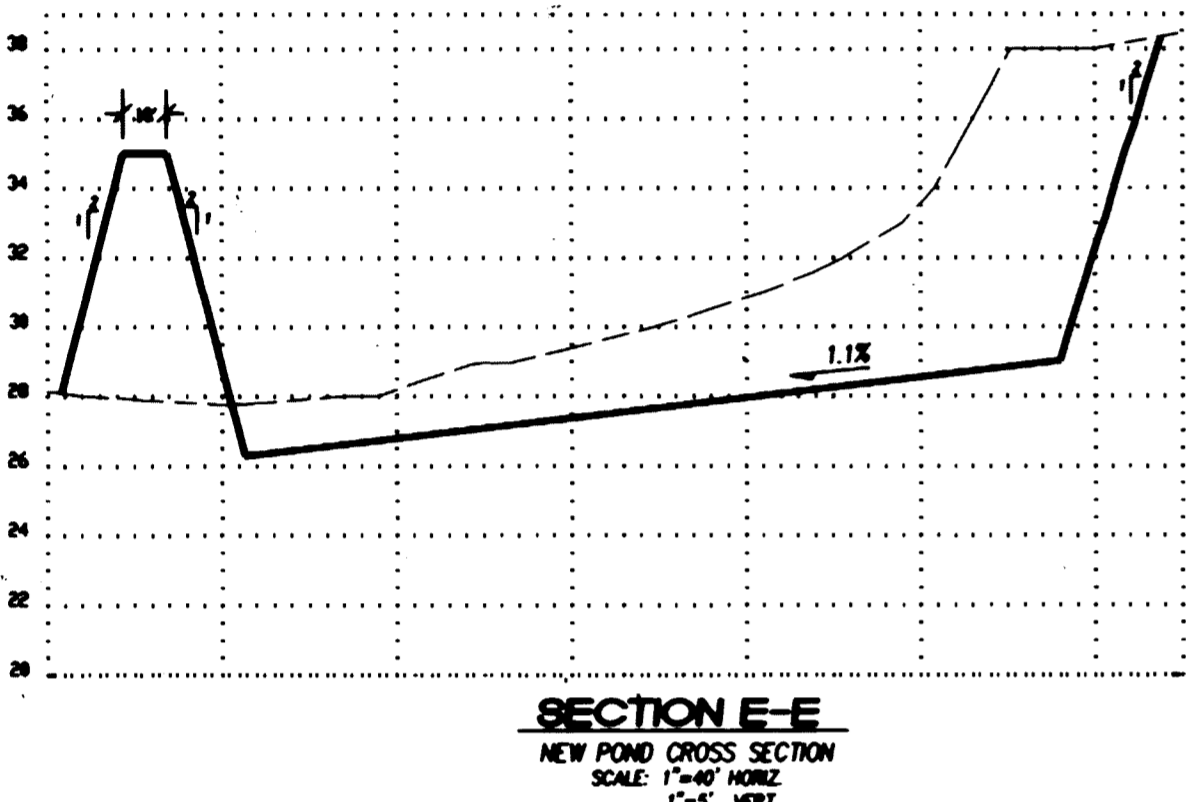
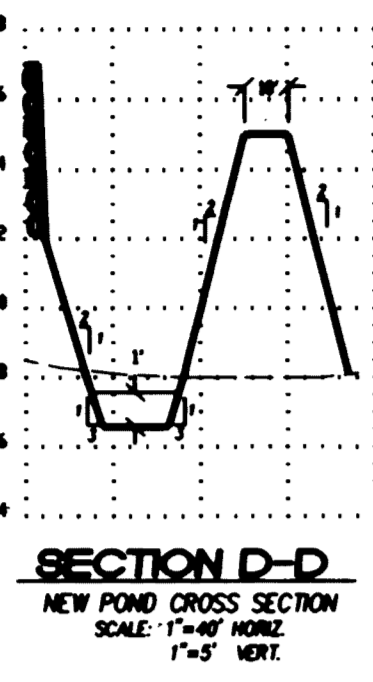
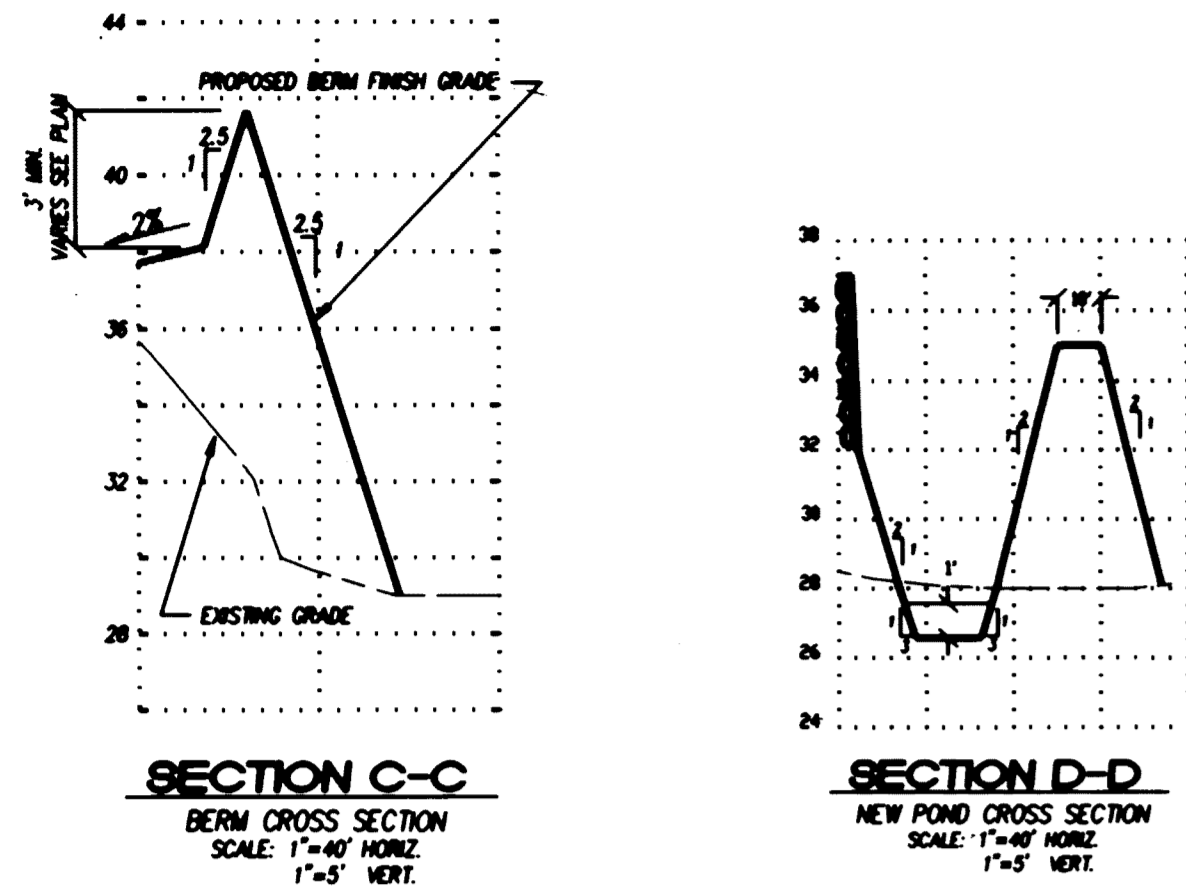

TEMPORARY EROSION AND SEDIMENTATION CONTROL NOTES:

- ALL REQUIRED SEDIMENTATION AND EROSION CONTROL FACILITIES MUST BE CONSTRUCTED AND IN OPERATION PRIOR TO ANY LAND CLEARING AND/OR OTHER CONSTRUCTION TO ENSURE THAT SEDIMENT LADEN WATER DOES NOT ENTER THE NATURAL DRAINAGE SYSTEM. ALL EROSION AND SEDIMENT FACILITIES SHALL BE MAINTAINED IN A SATISFACTORY CONDITION AS DETERMINED BY THE CITY UNTIL SUCH TIME THAT CLEARING AND/OR CONSTRUCTION IS COMPLETED AND THE POTENTIAL FOR ON-SITE EROSION HAS PASSED. THE IMPLEMENTATION, MAINTENANCE, REPLACEMENT, AND ADDITIONS TO THE EROSION AND SEDIMENTATION CONTROL SYSTEMS SHALL BE THE RESPONSIBILITY OF THE PERMITTEE.
- THE EROSION AND SEDIMENTATION CONTROL SYSTEM DEPICTED ON THESE PLANS ARE INTENDED TO BE MINIMUM REQUIREMENTS TO MEET ANTICIPATED SITE CONDITIONS. AS CONSTRUCTION PROGRESSES AND UNEXPECTED OR SEASONAL CONDITIONS DICTATE, FACILITIES WILL BE NECESSARY TO ENSURE COMPLETE SITUATION CONTROL ON THE SITE. DURING THE COURSE OF CONSTRUCTION, IT SHALL BE THE OBLIGATION AND RESPONSIBILITY OF THE PERMITTEE TO ADDRESS ANY NEW CONDITIONS THAT MAY BE CREATED BY HIS ACTIVITIES AND TO PROVIDE ADDITIONAL FACILITIES OVER AND ABOVE THE MINIMUM REQUIREMENTS. SENSITIVE AREAS, NATURAL WATER COURSES AND/OR STORM DRAINAGE SYSTEMS.
- APPROVAL OF THESE PLANS IS FOR EROSION AND SEDIMENTATION CONTROL ONLY. IT DOES NOT CONSTITUTE AN APPROVAL OF STORM DRAINAGE DESIGN, SIZE NOR LOCATION OF PIPES, RESTRICTORS, CHANNELS, OR RETENTION FACILITIES.
- ANY DISTURBED AREA WHICH HAS BEEN STRIPPED OF VEGETATION AND WHERE NO FURTHER WORK IS ANTICIPATED FOR A PERIOD OF 30 DAYS OR MORE, MUST BE IMMEDIATELY STABILIZED WITH MULCHING, GRASS PLANTING, OR OTHER APPROVED EROSION CONTROL TREATMENT APPLICABLE TO THE TIME OF YEAR IN QUESTION. GRASS SEEDING ALONE WILL BE ACCEPTABLE ONLY DURING THE MONTHS OF APRIL THROUGH SEPTEMBER INCLUSIVE. SEEDING MAY PROCEED OUTSIDE THE SPECIFIED TIME PERIOD WHENEVER IT IS IN THE INTEREST OF THE PERMITTEE, BUT MUST BE AUGMENTED WITH MULCHING, NETTING, OR OTHER TREATMENT APPROVED BY THE CITY.
- IN CASE EROSION OR SEDIMENTATION OCCURS TO ADJACENT PROPERTIES, ALL CONSTRUCTION WORK WITHIN THE DEVELOPMENT THAT WILL FURTHER AGGRAVATE THE SITUATION, MUST CEASE AND THE OWNER/CONTRACTOR WILL IMMEDIATELY COMMENCE RESTORATION METHODS. RESTORATION ACTIVITY WILL CONTINUE UNTIL SUCH TIME AS THE AFFECTED PROPERTY OWNER IS SATISFIED.

LIMITS OF WORK THIS CONTRACT

OFF-SITE WORK BY OTHERS

NO WORK SHALL BE DONE WITHIN THE SHORELINE MANAGEMENT AREA (WHICH IS 5' SOUTH OF PROPERTY LINE) PRIOR TO ISSUANCE OF A STORMWATER MANAGEMENT SUBSTANTIAL DEVELOPMENT PERMIT.

NORTH LEVEE ROAD

CONSTRUCTION SEQUENCE

- HOLD PRE-CONSTRUCTION MEETING
- INSTALL GRAVEL CONSTRUCTION ENTRANCES
A) BY SEPARATE PERMIT IN SHORELINE AREA
OR
B) BY ALTERNATE ROUTE OUTSIDE SHORELINE AREA
- INSTALL SILTATION FENCE
- CALL FOR INSPECTION FROM CITY OF PUYALLUP
- CLEAR AND GRUB AREA OF SITE TO BE PRELOADED, AREA PROCEED FOR STOCKPILE, AND AREA TO ACCEPT NATIVE SOIL FROM PRELOAD AREA
- STOCKPILE MATERIALS TO REMAIN ONSITE, STRIPPING FOR LANDSCAPE BERMS
- CONDUCT MASS GRADING NEEDED TO ACCOMPLISH PRELOAD
- IMPORT AND PLACE PRELOAD MATERIAL
- LEAVE SITE TO ALLOW PRELOAD TO SETTLE
- RETURN TO SITE ONCE PRELOAD IS SETTLED
- COMPLETE MASS GRADING
- INSTALL PERMANENT STORM DRAINAGE SYSTEM AS NOTED. CATCH BASINS SHALL BE INSTALLED NINE INCHES BELOW FINISHED GRADE TO ALLOW FOR TEMPORARY PLACING FRAME AND GRATE TO COLLECT STORM WATER RUNOFF DURING CONSTRUCTION
- INSTALL FILTER FABRIC BARRIERS AT ALL CATCH BASINS TO BE INSTALLED AS PART OF T.E.S.C.
- INSTALL SANITARY SEWER SYSTEM IN CONNECTION WITH STEP #8
- BUILDING CONSTRUCTION BEGINS
- LANDSCAPE CONTRACTOR TO HYDROSEED DISTURBED AREAS WITHIN THREE WEEKS OF LAST PLANNED DISTURBANCE OF AREA OR AS DIRECTED BY THE CITY ENGINEER (FOR AREAS TO BE HYDROSEED SEE LANDSCAPE PLANS)
- INSTALL PAVEMENT
- CALL CITY OF PUYALLUP FOR INSPECTION PRIOR TO #15
- ONCE SITE IS STABILIZED, REMOVE TEMPORARY EROSION CONTROL FACILITIES
- ALL FILL MATERIAL IN PIERCE AND INTER-COUNTY RIVER IMPROVEMENT PROPERTY SHALL BE CLEAN AND FREE OF DEBRIS, WASTE AND GARBAGE. ALL WORKMANSHIP AND MATERIALS SHALL COMPLY WITH THE WSDOT/APWA 1994 STANDARD SPECIFICATIONS FOR ROAD, BRIDGE AND MUNICIPAL CONSTRUCTION.



TITLE: SERTA MATTRESS COMPANY GRADING AND T.E.S.C. PLAN
CLIENT: PACIFIC DESIGN GROUP, P.S. 625 COMMERCE ST. SUITE 310 TACOMA, WA 98402

PROJECT MANAGER: BRUCE A. MARTIN, PE
SIGNATURE: *[Signature]*

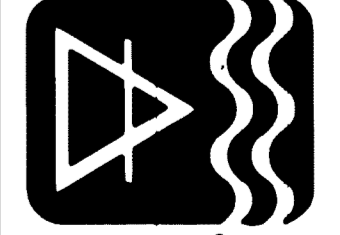

PAC-TECH Engineering, Inc.
Engineers / Planners / Surveyors / Environmental Specialists
12720 Gateway Drive
Tacoma, WA 98402
Phone: (253) 473-1100
Fax: (253) 473-1101

SHEET 2 OF 2
FILE NO: R3270-4

REVISION NO.	REVISION DESCRIPTION	DATE BY
5	RELOCATED POND BERM OFF FORM R.O.W.	11/23/94 B.M.
4	REVISED POND GRADING	11/16/94 B.A.M.
3	REVISED BROWLADE OUTLET ELEV AND CONSTRUCTION SEQ.	6/16/94 S.A.J.
2	ADDED GRADING, EROSION NOTES, CONSTRUCTION SEQUENCE	5/29/94 B.A.M.
1	ADDED CROSS-SECTIONS	4/20/94 J.R.E.

Appendix B

- Geotechnical Engineering Report – GeoEngineers

Geotechnical Engineering Services Report

Coastal Pacific Food Distributors
Freezer Expansion
322 Valley Avenue NW
Puyallup, Washington

for
Coastal Pacific Food Distributors

January 5, 2024



1101 South Fawcett Avenue, Suite 200
Tacoma, Washington 98402
253.383.4940

Geotechnical Engineering Services Report
Coastal Pacific Food Distributors
Freezer Expansion
Puyallup, Washington

File No. 27044-001-00

January 5, 2024

Prepared for:

Coastal Pacific Food Distributors
1015 Performance Drive
Stockton, California 95206

Attention: Kevin Carpenter

Prepared by:

GeoEngineers, Inc.
1101 South Fawcett Avenue, Suite 200
Tacoma, Washington 98402
253.383.4940

Clinton Lindgren, PE
Geotechnical Engineer

Dennis (DJ) Thompson, PE
Associate

CJL:DJT:leh

Disclaimer: Any electronic form, facsimile or hard copy of the original document (email, text, table, and/or figure), if provided, and any attachments are only a copy of the original document. The original document is stored by GeoEngineers, Inc. and will serve as the official document of record.

Table of Contents

1.0 INTRODUCTION AND PROJECT UNDERSTANDING.....	1
2.0 PURPOSE AND SCOPE OF SERVICES	1
3.0 SITE CONDITIONS.....	2
3.1. Surface Conditions.....	2
3.2. Literature Review	2
3.2.1. Geology	2
3.2.2. Natural Resources Conservation Service (NRCS) Description	2
3.2.3. 2004 Report Explorations.....	2
3.3. Subsurface Conditions	3
3.3.1. Soil Conditions.....	3
3.3.2. Groundwater Conditions	3
4.0 CONCLUSIONS AND RECOMMENDATIONS	4
4.1. General.....	4
4.2. Seismic Design Considerations.....	5
4.2.1. Seismic Design Parameters.....	5
4.2.2. Liquefaction	6
4.2.3. Liquefaction Mitigation	7
4.2.4. Lateral Spreading Potential	8
4.2.5. Surface Rupture Potential	8
4.3. Site Development and Earthwork.....	8
4.3.1. General.....	8
4.3.2. Clearing and Stripping.....	8
4.3.3. Temporary Erosion and Sedimentation Control	9
4.3.4. Temporary Excavations and Cut Slopes.....	9
4.3.5. Permanent Cut and Fill Slopes	10
4.3.6. Temporary Groundwater Handling Considerations	10
4.3.7. Surface Drainage.....	10
4.3.8. Subgrade Preparation and Protection.....	11
4.4. Fill Materials.....	12
4.4.1. Structural Fill.....	12
4.4.2. Select/Wet Weather Granular Structural Fill	12
4.4.3. Crushed Rock	12
4.4.4. Quarry Spalls.....	12
4.4.5. Pipe Bedding.....	12
4.4.6. Trench Backfill	13
4.4.7. On-site Soil as Structural Fill.....	13
4.5. Fill Placement and Compaction	13
4.6. Shallow Foundations	13
4.6.1. General.....	13
4.6.2. Footing Bearing Surface Preparation.....	14
4.6.3. Dimensions and Allowable Soil Bearing Pressure.....	14
4.6.4. Shallow Foundations Near Existing Improvements.....	15

4.6.5. Foundation Settlement	15
4.6.6. Lateral Resistance.....	15
4.6.7. Foundation Drains.....	16
4.7. Slab-on-Grade Floors	16
4.8. Retaining Walls and Below-Grade Structures	17
4.8.1. Design Parameters.....	17
4.8.2. Retaining Structure Drainage	18
4.9. Infiltration Feasibility Assessment	18
4.9.1. General.....	18
4.10. Pavement Design.....	19
4.10.1. General Design Criteria	19
4.10.2. Pavement Construction Considerations.....	19
4.10.3. Asphalt Concrete Pavement Design.....	19
4.10.4. Portland Cement Concrete.....	20
5.0 LIMITATIONS	21
6.0 REFERENCES	21

LIST OF FIGURES

Figure 1. Vicinity Map

Figure 2. Site Plan

APPENDICES

Appendix A. Subsurface Explorations and Laboratory Testing

 Figure A-1 – Key to Exploration Logs

 Figures A-2 through A-6 – Logs of Borings

 Figure A-7 – Sieve Analysis Results

Appendix B. 2004 Report Explorations

Appendix C. Report Limitations and Guidelines for Use

1.0 INTRODUCTION AND PROJECT UNDERSTANDING

GeoEngineers, Inc. (GeoEngineers) is pleased to present this report providing the results of our geotechnical engineering services for the proposed Coastal Pacific Food Distributors Freezer Expansion project. The project site is located at 322 Valley Avenue NW in Puyallup, Washington. A Vicinity Map showing the approximate project location is provided as Figure 1. Our project understanding is based on our discussions with the project owner's representative, the project civil and structural engineers, other project team members, our previous involvement at the project site, and our review of the following:

- 30 percent plans for the expansion prepared by AWB Engineers and dated July 28, 2023 (provided).
- Project plans for the existing development prepared by HGA Architects and Engineers, LLP and dated October 1, 2004 (provided).
- As-built plans for the existing development prepared by AHBL and dated September 7, 2005 (provided).
- Preliminary design plans for a water tank, including calculations, prepared by CST Storage dated December 12, 2023.
- Geotechnical report for the existing development prepared by GeoEngineers and dated August 18, 2004 (in-house, "2004 Report"). Our 2004 Report included completion of explorations (drilled borings, cone penetrometer tests [CPTs], and test pits) to support analysis for design and construction of the existing development.

The existing facility consists of a single-story structure that consists of an office area, loading dock, and a freezer (warehouse-type) area. The structure is surrounded by paved parking and driveway areas, concrete, and landscaping. Specific development plans are still being finalized; however, we understand the proposed improvements will include expanding the existing facility by connecting to the existing structure and almost tripling the building footprint to nearly 50,000 square feet. Existing structure foundations are reported to accommodate structurally tying in and supporting the expansion; in some cases, new footings will be constructed. Other site improvements include design and construction of a water tank proposed in the northeastern-eastern portion of the site, utilities and pavements, minor grading, and stormwater management. Stormwater facilities will be designed based on criteria provided in the 2019 Washington State Department of Ecology Stormwater Management Manual for Western Washington (SMMWW) and other requirements set forth by the City of Puyallup.

2.0 PURPOSE AND SCOPE OF SERVICES

The purpose of our geotechnical engineering services is to complete subsurface explorations, including a groundwater monitoring well, to characterize soil conditions at the project site and to provide recommendations for geotechnical design and development of the proposed improvements. Our specific scope of services is provided in our proposal dated October 2, 2023 and executed October 3, 2023, and can be provided upon request.

3.0 SITE CONDITIONS

3.1. Surface Conditions

The overall property consists of a rectangular-shaped parcel totaling approximately 5 acres. The property is bounded by existing commercial developments to the north, east and west, and by a section of the future State Route (SR) 167 extension to the south. The Puyallup River is located about 1,000 feet south of the property.

The existing building is located in the central portion of the property and is typically surrounded by landscaping and/or pavements. Vegetated stormwater ponds on the order of 5 to 6 feet deep are located on the north and south sides of the existing building. The remainder of the property generally consists of parking areas, planters, and undeveloped vegetated areas including small trees, which typically border the site.

Site topography is generally level with grade change across property around a few feet or less. Existing site elevations are around Elevation (EL) 39 feet to EL 41 feet. Elevations referenced herein are referenced to the North American Vertical Datum of 1988 (NAVD 88).

3.2. Literature Review

3.2.1. Geology

We reviewed the “Geologic Map of the Tacoma 1:100,000-scale Quadrangle, Washington” (Schuster et al. 2015). According to the map, the site is underlain by Holocene-aged alluvium (Qa). Alluvium is typically described as silt, sand and gravel with occasional estuarine deposits that can be relatively siltier. Alluvium is a water-deposited unit that has not been glacially consolidated and is typically loose to medium dense.

3.2.2. Natural Resources Conservation Service (NRCS) Description

According to the NRCS Web Soil Survey (accessed December 5, 2023) the proposed development area is generally underlain by two soil types: Puyallup fine sandy loam (Unit 31A) and Sultan silt loam (Unit 42A). The Puyallup fine sandy loam is the primary mapped unit and covers the majority of the site; the sultan silt loam is only mapped in the southwest corner of the site.

Puyallup fine sandy loam is described as well drained with a high capacity of the most limiting layer to transmit water and classified in Hydrologic Soil Group A. Sultan silt loam is described as moderately well drained with a moderately high capacity of the most limiting layer to transmit water. Sultan silt loam is classified in Hydrologic Soil Group C/D.

3.2.3. 2004 Report Explorations

Our 2004 Report was completed to support design and construction of the existing development. In preparation of our 2004 Report, we completed 2 drilled borings (B-1 and B-2), 3 CPTs (CPT-1 through CPT-3), and 5 test pits (TP-1 through TP-5) at the site. Approximate locations of the 2004 Report explorations are shown on the Site Plan, Figure 2 and the exploration logs are included in this report in Appendix B. Borings were advanced to depths between about 30 and 50 feet below the existing ground surface (bgs), CPTs extended to about 30 feet bgs, and test pits were excavated to between 8 and 12 feet bgs. Based on our review of the 2004 Report explorations, we interpret two general soil units at the project site: (1) fill and (2) alluvium. A brief description of each unit is provided below.

Fill material was documented in some, but not all, of the 2004 Report explorations (B-1, TP-1, and CPT-1). Where encountered, fill material consisted of loose to dense sand and gravel with variable silt content. Fill extended to depths between about 1½ and 4 feet bgs.

Below the fill in B-1, TP-1, and CPT-1 and beginning near the ground surface of the other explorations, soils we interpret to be alluvium were observed. Alluvium typically consisted of loose to medium dense sand with variable silt content and intermittent approximately 2- to 5-foot-thick layers of medium stiff to very stiff silt. Organic matter consisting of wood fragments was occasionally noted within the alluvium. All the 2004 Report explorations were completed in alluvium at depths between about 12 and 50 feet bgs.

Groundwater was noted in the 2004 Report borings at depths between about 16 and 16½ feet bgs.

3.3. Subsurface Conditions

We explored subsurface conditions at the site for this study by completing five drilled borings (GEI-1 through GEI-5) at the approximate locations shown in Figure 2. Boring GEI-1 was completed as a monitoring well. A pressure transducer was installed in the well to measure groundwater pressures at regular intervals. Details regarding the subsurface exploration program, including summary logs of the explorations, are provided in Appendix A.

Selected samples from our explorations were tested to evaluate engineering properties and to confirm or modify field classifications. Our testing program consisted of grain-size distribution analyses, hydrometer analyses, moisture content determinations, and fines content determinations. Details and the results of our laboratory testing program are provided in Appendix A.

3.3.1. Soil Conditions

At the surface of the borings, we observed surficial material to consist of either asphalt concrete pavement or sod. Asphalt was observed in borings GEI-1 and GEI-5 with thickness on the order of 5 inches. Sod was observed in the remaining borings (GEI-2 through GEI-4) and was typically around 8 inches thick. Below the surficial material, we observed what we interpret to be native alluvium soils. Although not directly observed in the borings completed for this study, we expect that a few feet of fill material (likely consisting of reworked alluvium soils) could be present across the site as noted in our 2004 Report.

Alluvium varied in composition but typically consisted of interbedded layers of very loose to medium dense sand with variable silt content, soft to medium stiff silt with variable sand content, and isolated pockets of medium dense gravel with variable silt and sand content. Organic matter consisting of wood fragments was occasionally observed within the alluvium. All our borings were terminated within alluvium at depths between about 11½ and 31½ feet bgs.

3.3.2. Groundwater Conditions

Groundwater was observed during drilling of GEI-1 at depth of about 16¾ feet bgs. As previously discussed, we installed a well in GEI-1 with a pressure transducer. We will continue to monitor groundwater levels in the monitoring well and provide additional information in our final geotechnical report or a report addendum, as applicable.

Groundwater was not observed during drilling of the remaining borings, GEI-2 through GEI-5; however, they were terminated at about 11½ to 13 feet bgs. We did observe occasional mottling and iron-oxide staining, as noted on the boring logs, which are indications of intermittent presence of groundwater and/or seepage.

Based on our observations during drilling and our understanding of site geology, in our opinion groundwater observed at the site is likely representative of the regional groundwater table and present year-round. Based on current groundwater information, we recommend assuming a design groundwater depth of about 15 feet bgs (approximate EL 25 feet).

There is also the potential for perched groundwater to accumulate at relatively shallower depths. It is common for perched groundwater to be present near contacts where soil that is more permeable overlies soil that is less permeable (i.e., sand over silt). Site grading, especially utility cuts into low permeability soils (i.e., silt) that are backfilled with more permeable imported sands and gravels, can also affect the quantity and location of perched groundwater. Perched groundwater is expected to be intermittent and discontinuous at the project site.

The presence of groundwater and groundwater seepage can fluctuate depending on soil conditions, rainfall amounts, irrigation activities and other factors. We anticipate groundwater levels, and the presence of perched groundwater, will generally be highest during the wet season, typically October through May.

4.0 CONCLUSIONS AND RECOMMENDATIONS

4.1. General

Based on our understanding of the project, observations during our explorations and our experience with similar projects, it is our opinion that the proposed improvements can be constructed generally as envisioned with regards to geotechnical considerations. A summary of the primary geotechnical considerations for the project is provided below and is followed by our detailed recommendations.

- We identified potentially liquefiable soils in our explorations. We provide additional discussion on liquefaction and resulting settlement below. Total and differential settlement as a result of liquefaction should be anticipated without improvement to site soils (i.e., ground improvement installation).
- If estimated liquefaction settlement is not acceptable for desired performance of new structures, we expect that ground improvement could be installed at the site to limit liquefaction settlement to acceptable levels for new structures. We provide general discussion on ground improvement consisting of aggregate piers/stone columns.
- Due to the presence of potentially liquefiable soils, the site is Site Class F per American Society of Civil Engineers (ASCE) 7-16 and the 2018/2021 International Building Code (IBC), and a site-specific seismic evaluation could be required to determine seismic design parameters. ASCE 7-16 allows alternative code applications to be considered if the fundamental period of vibration of the structure is less than or equal to 0.5 seconds. We understand that the design will fall within these limits. We provide the ASCE 7-16 alternative code application below.
- New structures can be adequately supported using conventional shallow foundations and slabs-on-grade. Shallow foundations should be supported on a minimum 2-foot-thick bearing pad of imported

crushed rock structural fill. Additional bearing pad thickness may be required if unsuitable soils (i.e., organic-rich soil and/or soft silt) are present.

- Most of the site soils encountered, especially in the upper few feet of our explorations, contain a significant percentage of fines (material passing the U.S. No. 200 sieve). Soil with a higher fines content is more sensitive to small changes in moisture content and may be difficult, if not impossible, to work and compact during wet weather conditions. At this time, we recommend that on-site soils not be considered for reuse as structural fill.
- Groundwater at the site is expected to fluctuate depending on weather and time of year. At this time, we recommend assuming a static design depth to ground water of 15 feet bgs (Elevation 25 feet) for design. Additional groundwater elevation data at the site is being collected at the time of this study. This design groundwater level may be modified as additional groundwater data at the site is collected. Shallow groundwater seepage should be expected to be encountered during almost any time of the year.
- As previously discussed, most of the soils observed in our explorations contain a significant percentage of fines. We also noted intermittent and alternating layers of silt and sands. Based on our experience and laboratory testing of selected samples, the infiltration rate of the silt alluvium would be considered very low or practically infeasible. Site soil layering observed indicates variable and lack of consistent permeable conditions. As such, we do not recommend infiltration as a primary design solution for stormwater management control.

4.2. Seismic Design Considerations

4.2.1. Seismic Design Parameters

We performed an evaluation of seismic design parameters per ASCE 7-16. Based on our understanding of subsurface conditions at the site, we expect that potentially liquefiable soils are present. As a result, the site is Site Class F per ASCE 7-16, and a site-specific seismic evaluation is typically required to determine the seismic design parameters. ASCE 7-16 Section 20.3.1 indicates that for structures with a fundamental period of vibration less than or equal to 0.5 seconds, a site-specific seismic evaluation is not required, and a Site Class is permitted to be determined in accordance with Section 20.3. Provided this period criterion can be satisfied, ASCE 7-16 permits the use of, and we also recommend, using the seismic design parameters derived for Site Class D as shown in Table 1. Provisions for Site Class F are required for other elements of the code not directly related to the development of seismic design parameters (i.e., foundation design). If the fundamental period of vibration for the proposed structure exceeds 0.5 seconds, we should be notified to provide updated recommendations.

Further, per ASCE 7-16 Section 11.4.8, ground motion hazard analysis is required for structures on Site Class D with S_1 greater than or equal to 0.2. S_1 is greater than 0.2 for this site; therefore, this provision applies. Alternatively, per ASCE 7-16 Supplement 3 Section 11.4.8, a ground motion hazard analysis is not required where the value of S_{M1} is increased by 50 percent for all applications of S_{M1} and the resulting value of S_{D1} is used for all applications of S_{D1} . This exception was incorporated in the seismic design parameters provided in Table 1 below; however, we can perform ground motion hazard analysis if preferred by the design team.

TABLE 1. SEISMIC DESIGN CRITERIA

2018 IBC Parameters ¹	Value
Site Class	D
Mapped MCE _R Spectral Response Acceleration at Short Period, S _s (g)	1.28
Mapped MCE _R Spectral Response Acceleration at 1-second period, S ₁ (g)	0.44
Site Modified Peak Ground Acceleration, PGA _M	0.55
Short Period Site Coefficient, F _a	1.00
Long Period Site Coefficient, F _v	1.86
Design Spectral Acceleration at 0.2-second period, S _{Ds} (g)	0.85
Design Spectral Acceleration at 1.0-second period, S _{D1} (g)	0.82 ²
Site Modified Earthquake Spectral Response Acceleration at Short Periods, S _{Ms} (g)	1.28
Site Modified Considered Earthquake Spectral Response Acceleration at 1-Second Periods, S _{M1} (g)	1.23 ²

Notes:

¹ Parameters developed based on latitude 47.206508 and longitude -122.298852 using the Applied Technology Council (ATC) Hazards online tool (<https://hazards.atcouncil.org/>).

² Per ASCE 7-16 Supplement 3 Section 11.4.8 Item 1, parameter has been increased 50 percent or has increased by 50 percent as a result of the adjusted S_{M1} value.

4.2.2. Liquefaction

Liquefaction refers to a condition where vibration or shaking of the ground, usually from earthquake forces, results in development of excess pore pressures in loose, saturated soils and subsequent loss of strength in the deposit of soil affected. In general, soils that are susceptible to liquefaction include loose to medium dense sands to silty sands that are below the water table.

The evaluation of liquefaction potential is a complex procedure and is dependent on numerous site parameters including soil grain size, soil density, site geometry, static stress, and the design ground acceleration. Typically, the liquefaction potential of a site is evaluated by comparing the cyclic stress ratio (CSR), which is the ratio of the cyclic shear stress induced by an earthquake to the initial effective overburden stress, to the cyclic resistance ratio (CRR), which is the soil's resistance to liquefaction. Estimation of the CSR and the CRR were completed using empirical methods (Youd et al. 2001; Idriss and Boulanger 2014). Estimated ground settlement resulting from earthquake induced liquefaction was analyzed using empirical procedures based on standard penetration tests (from borings) and cone penetration tests (Cetin et al. 2009; Idriss and Boulanger 2014). We considered a 2,475-year return period design earthquake event as per IBC 2018 design guidelines. The following design earthquake event parameters were used in our analyses:

- Peak ground acceleration (PGA_m) of 0.55g, per IBC 2018 Site Class D design response spectra determined for the site.
- Mean magnitude earthquake of 7.11 for the 2,475-year return event determined for the site and obtained from the online interactive United States Geological Survey (USGS) Unified Hazard Tool.

The results of our liquefaction analysis indicate significant free field ground settlement may occur due to liquefaction for the design earthquake event considered. Potentially liquefiable soils were observed

beginning around 15 feet bgs and intermittently extending to the full depths explored (up to about 50 feet bgs considering our 2004 Report explorations). We estimate the total liquefaction-induced (uniform) settlements at the site could be on the order of about 2 to 5 inches. Differential settlements over a distance of about 100 feet are estimated to be up to about 2.5 inches.

The owner and the design team should decide if these estimated settlements are acceptable for the proposed improvements. If not, the design should be completed to mitigate or account for liquefaction. We anticipate that potential options could include deep foundations or, likely more practical for the project site, ground improvements consisting of stone columns.

4.2.3. Liquefaction Mitigation

4.2.3.1. General

If determined that liquefiable soils are present at the site and estimated liquefaction-induced settlements are not tolerable for the proposed development, mitigation measures such as ground improvement could be considered. In some cases, deep foundations may be installed to mitigate liquefaction; however, in our opinion, ground improvement is likely more cost effective and suitable for the project site.

The sections below provide general discussion on ground improvement. Additional analysis and potential explorations would be required to compare with our liquefaction analysis and further investigate final design, planning, and construction of mitigation measures, if planned.

4.2.3.2. Ground Improvement

There are a few alternatives and construction contractors that design and install ground improvements using aggregates (aggregate improvements). Some of these ground improvement systems are proprietary. Based on our current understanding of soil conditions at the site, we anticipate that a rammed aggregate pier (RAP) system or stone column systems (vibro-replacement) are likely the best suited ground improvement methods for this site. Rigid inclusions are also a possibility, wherein instead of aggregate, wet concrete is used instead and installed more like an augercast pile.

Aggregate improvements consist of discrete columns of compacted crushed rock that are installed below grade with an auger (RAPs) or a vibratory mandrel (stone columns) on a regular pattern that encompasses the entire building footprint. There are several benefits that can be achieved by installing aggregate improvements, including reducing the magnitude of static settlement, increasing the allowable soil bearing resistance, mitigating liquefaction induced settlements and/or reducing the magnitude of differential settlements.

Aggregate improvements are typically designed and installed by a specialty ground improvement contractor performing the work based on a set of design criteria and performance requirements. GeoEngineers can also provide full ground improvement design services. The increase in performance/density of the subsurface soil conditions after installation of the aggregate improvements is also estimated based on in-situ testing to confirm the design and analysis. Performance criteria is established by the design team and typically includes requirements on a target soil depth(s), bearing resistance, tolerances for static and liquefaction induced settlements (both total and differential), field observation records, and subsurface conditions after the improvements. We expect that higher allowable soil bearing pressures (typically about 4,000 to 6,000 pounds per square foot [psf]) than provided in the “Shallow Foundations” section of this report are possible if ground improvement is installed below foundations.

Total liquefaction settlement after installation of aggregate improvements (or rigid inclusions) will depend on the length of the columns and the thickness/depth of the liquifiable soil layers. If there are liquifiable soils deep and below the bottom of the ground improvements, there is a potential that some settlement at the ground surface could still occur as a result of liquefaction. If this condition is determined, the goal of the ground improvement would be a design that allows the structure to settle more uniformly and reduce estimated differential settlement to a tolerable range.

4.2.4. Lateral Spreading Potential

Lateral spreading related to seismic activity typically involves lateral displacement of large, surficial blocks of non-liquefied soil when a layer of underlying soil loses strength during seismic shaking. Lateral spreading usually develops in areas where sloping ground or large grade changes (including retaining walls) are present. Based on our understanding of site topography, and proposed improvements, it is our opinion that the risk of lateral spreading is low.

4.2.5. Surface Rupture Potential

According to the USGS Interactive Fault Map (accessed December 12, 2023), there are no mapped faults or other seismogenic features within about 4 miles of the site. Based on the proximity of the site to the nearest mapped seismogenic feature and our understanding of local geology (bedrock below the project site overlain by hundreds of feet of soil) it is our opinion the risk for surface rupture at this site is low.

4.3. Site Development and Earthwork

4.3.1. General

We anticipate site development and earthwork activities on site will include: clearing and stripping vegetated areas; site grading; establishing subgrades for driveways, parking areas, and building foundations; and placing and compacting fill and backfill materials. We expect site grading and earthwork can be accomplished with conventional earthmoving equipment.

4.3.2. Clearing and Stripping

Existing surfaces within proposed building areas should be cleared and stripped of all vegetation and organics prior to site development. Minimum estimated stripping depths at the site will likely be on the order of 8 inches. However, greater stripping depths could be required to remove localized zones of loose or organic-rich soil, especially in areas of the site currently vegetated with trees. During clearing and stripping, stumps and primary root systems of shrubs and trees should be completely removed. Voids caused by removal of stumps and/or root systems should be backfilled with compacted structural fill.

Based on our explorations we anticipate soils exposed after stripping could have a high fines content and, thus, be susceptible to disturbance when wet. Care should be taken to avoid allowing these soils to become saturated and disturbed. We provide recommendations for subgrade protection in the "Subgrade Preparation and Protection" section below.

Although not observed in our explorations, cobbles and/or boulders should be removed from structural areas, if encountered. Boulders may be removed from the site or used in landscape areas. Voids caused by boulder removal should be backfilled with structural fill.

Structural elements of the existing buildings and pavements should be demolished and removed from within the footprint of the new improvements. During demolition, excessive disturbance of surficial soils may occur, especially if left exposed and/or conducted in wet conditions. Disturbed soils may require additional remediation during construction and grading.

4.3.3. Temporary Erosion and Sedimentation Control

Erosion and sedimentation rates and quantities can be influenced by construction methods, slope length and gradient, amount of soil exposed and/or disturbed, soil type, construction sequencing and weather. Implementing an erosion and sedimentation control plan will reduce the project impact on erosion-prone areas. The plan should be designed in accordance with applicable city, county, and state standards. The plan should incorporate basic planning principles, including:

- Scheduling grading and construction to reduce soil exposure;
- Re-vegetating or mulching denuded areas;
- Directing runoff away from exposed soils;
- Reducing the length and steepness of slopes with exposed soils;
- Decreasing runoff velocities;
- Preparing drainage ways and outlets to handle concentrated or increased runoff;
- Confining sediment to the project site;
- Inspecting and maintaining control measures frequently.

Some sloughing and raveling of exposed or disturbed soil on slopes should be expected. We recommend disturbed soil be restored promptly so surface runoff does not become channeled.

Temporary erosion protection should be used and maintained in areas with exposed or disturbed soils to help reduce erosion and reduce transport of sediment to adjacent areas and receiving waters. Permanent erosion protection should be provided by paving, structure construction or landscape planting.

Until permanent erosion protection is established, and the site is stabilized, site monitoring may be required by qualified personnel to evaluate the effectiveness of the temporary erosion control measures and to repair and/or modify them as appropriate. Provisions for modifications to the erosion control system based on monitoring observations should be included in the erosion and sedimentation control plan.

4.3.4. Temporary Excavations and Cut Slopes

Based on our explorations, it is likely shallow excavations could experience minor caving. Excavations deeper than 4 feet should be shored or laid back at a stable slope if workers are required to enter. Shoring and temporary slope inclinations must conform to the provisions of Title 296 Washington Administrative Code (WAC), Part N, "Excavation, Trenching and Shoring." Shoring, trench boxes or sloped sidewalls will be required under the Washington Industrial Safety and Health Act (WISHA), regardless of the soil type encountered in the excavation. We recommend contract documents specify that the contractor performing the work is responsible for selecting excavation and dewatering methods, monitoring the excavations for safety and providing shoring, as required, to protect personnel and structures.

We recommend for general planning purposes all temporary cut slopes be inclined no steeper than about 1.5H:1V (horizontal:vertical). This guideline assumes all surface loads remain a minimum distance of at least one-half the depth of the cut away from the top of the slope and seepage is not present on the slope face. Flatter cut slopes will be necessary where seepage occurs or if surface surcharge loads are anticipated. Temporary covering with heavy plastic sheeting should be used to protect these slopes during periods of wet weather.

4.3.5. Permanent Cut and Fill Slopes

We recommend permanent slopes be constructed at a maximum inclination of 2H:1V to manage erosion. Where 2H:1V permanent slopes are not feasible, protective facings and/or retaining structures should be considered.

To achieve uniform compaction of fill slopes, we recommend fill slopes be overbuilt and subsequently cut back to expose well-compacted fill. Fill placement on existing slopes steeper than 5H:1V should be benched into the slope face. The configuration of benches depends on the equipment being used and the inclination of the existing slope. Bench excavations should be level and extend into the slope face at least half the width of the compaction equipment used.

Exposed areas should be re-vegetated as soon as practical to reduce surface erosion and sloughing. Temporary protection should be used until permanent protection is established.

4.3.6. Temporary Groundwater Handling Considerations

As previously discussed, we expect that static groundwater at the site is present around 15 feet bgs (EL 25 feet). Perched groundwater could be encountered above this depth, although perched groundwater is expected to be intermittent and discontinuous. We anticipate groundwater levels will vary throughout the year and will generally be highest during the wet season, typically October through May. We expect perched groundwater could be encountered depending on the time of year of construction, likely near contacts where soil that is more permeable overlies soil that is less permeable (i.e., sand over silt).

Groundwater handling needs will typically be lower during the late summer and early fall months. We anticipate shallow perched groundwater can typically be handled adequately with sumps, pumps, and/or diversion ditches, as necessary. Perched groundwater at relatively shallow depths is typically surface water that has recently infiltrated the ground surface. Proactive handling of surface water (i.e., grading to reduce ponding) can reduce groundwater handling needs. If excavations extend more than a few below the static groundwater level (about 15 feet bgs), a more robust dewatering system such as well points will be necessary to maintain a dry excavation. Ultimately, we recommend the contractor performing the work be made responsible for controlling and collecting groundwater encountered.

4.3.7. Surface Drainage

Surface water from roofs, driveways and landscape areas should be collected and controlled. Curbs or other appropriate measures such as sloping pavements, sidewalks and landscape areas should be used to direct surface flow away from buildings, erosion sensitive areas and from behind retaining structures. Roof and catchment drains should not be connected to wall or foundation drains.

4.3.8. Subgrade Preparation and Protection

Subgrades that will support structures or paving should be thoroughly compacted to a uniformly firm and unyielding condition on completion of stripping and demolition, prior to placing structural fill. We recommend subgrades for structures and pavement be evaluated, as appropriate, to identify areas of yielding or soft soil. Probing with a steel probe rod or proof-rolling with a heavy piece of wheeled construction equipment are appropriate methods of evaluation, where practical.

If soft or otherwise unsuitable subgrade areas are revealed during evaluation which cannot be compacted to a stable and uniformly firm condition, we recommend: (1) the unsuitable soils be scarified (e.g., with a ripper or farmer's disc), aerated and recompact, if practical; or (2) the unsuitable soils be removed and replaced with compacted structural fill, as needed.

Near surface site soils encountered in our explorations contain a significant amount of fines and will be susceptible to disturbance during periods of wet weather. Soil with high fines content is very sensitive to small changes in moisture and is susceptible to disturbance from construction traffic when wet or if earthwork is performed during wet weather. The wet weather season generally begins in October and continues through May in western Washington; however, periods of wet weather can occur during any month of the year. In our opinion, earthwork will be most efficient during the summer months or during periods of extended dry weather. If wet weather earthwork is unavoidable, we offer the following recommendations:

- The ground surface in and around the work area should be sloped so that surface water is directed away from the work area. The ground surface should be graded so that areas of ponded water do not develop. Measures should be taken by the contractor to prevent surface water from collecting in excavations and trenches. Measures should be implemented to remove surface water from the work area.
- Earthwork activities should not take place during periods of heavy precipitation.
- Slopes with exposed soils should be covered with plastic sheeting.
- The contractor should take necessary measures to prevent on-site soils and other soils to be used as fill from becoming wet or unstable. These measures may include the use of plastic sheeting, sumps with pumps and grading. The site soils should not be left uncompacted and exposed to moisture. Sealing exposed soils by compacting with a smooth-drum roller or other appropriate compaction equipment prior to periods of precipitation will help reduce the extent to which these soils become wet or unstable.
- Construction traffic should be restricted to specific areas of the site, preferably areas that are surfaced with working pad materials not susceptible to wet weather disturbance.
- Construction activities should be scheduled so that the length of time that soils are left exposed to moisture is reduced to the extent practical.
- Protective surfacing such as placing asphalt-treated base (ATB) or haul roads made of quarry spalls or a layer of free-draining material such as well-graded pit-run sand and gravel may be necessary to protect completed areas from construction traffic, if needed. Typically, minimum gravel thicknesses on the order of 24 inches are necessary to provide adequate subgrade protection. Maintaining the existing

asphalt surfacing is also an adequate method of protection; however, asphalt could become distressed and may need repairs depending on the amount of heavy truck traffic.

Foundation bearing surface protection should also be considered. We provide additional recommendations in the “Shallow Foundations” section of this report.

4.4. Fill Materials

4.4.1. Structural Fill

The workability of material for use as structural fill will depend on the gradation and moisture content of the soil. Material used for general structural fill should be free of debris, organic contaminants, and rock fragments larger than 6 inches. For most applications, we recommend that structural fill consist of material similar to “Select Borrow” or “Gravel Borrow” as described in Section 9-03.14 of the Washington State Department of Transportation (WSDOT) Standard Specifications. Ultimately, time of year (wet weather vs. dry weather) of attainment and use of materials should be one of the considerations to determine imported material types.

4.4.2. Select/Wet Weather Granular Structural Fill

Weather, material use, schedule, duration exposed, and site conditions should be considered when determining the type of import fill materials purchased and brought to the site for use as structural fill. If imported fill material is required during periods of wet weather, it should consist of select granular structural fill. Select granular structural fill should consist of material similar to WSDOT Specification 9-03.9 (Aggregates for Ballast and Crushed Surfacing) or 9-03.10 (Aggregate for Gravel Base) with the exception that the fines content be less than 5 percent, based on the minus $\frac{3}{4}$ -inch fraction, and the maximum particle size is 6 inches. Gravel backfill for walls as described in WSDOT Specification 9-03.12(2) could also be considered for use as select granular fill. Alternative materials may be considered and should be reviewed and accepted by the project civil and geotechnical engineer.

4.4.3. Crushed Rock

Crushed surfacing base course (CSBC) and crushed surfacing top course (CSTC) should conform to applicable sections of 4-04 and 9-03.9(3) of the WSDOT Standard Specifications. We recommend that crushed rock used as structural fill consist of material of approximately the same quality as CSBC. For pavement sections, CSTC may be used where fine grading or grade control is desired.

4.4.4. Quarry Spalls

Quarry spalls should conform to WSDOT requirements 9-13.1(5). If necessary, some variations regarding the particle sizes of this specification, including sizes up to about 8 inches, may be appropriate.

4.4.5. Pipe Bedding

Trench backfill for the bedding and pipe zone should consist of well-graded granular material similar to “Gravel Backfill for Pipe Zone Bedding” described in Section 9-03.12(3) of the WSDOT Standard Specifications. The material must be free of roots, debris, organic matter, and other deleterious material. Other materials may be required depending on pipe manufacturer specifications and/or jurisdictional requirements and should be considered.

4.4.6. Trench Backfill

Trench backfill must be free of debris, organic material, and rock fragments larger than 6 inches. We recommend trench backfill material consist of imported material similar to “Select Borrow” or “Gravel Borrow” as described in the “Structural Fill” section above. During wet weather, select/wet weather granular fill may be required as trench backfill. Pipe manufacturer and jurisdictional requirements should also be considered when choosing trench backfill material.

4.4.7. On-site Soil as Structural Fill

Based on our explorations, near-surface soils at the site typically contain high silt content, are moisture sensitive, and will likely be generated above optimum moisture content and will be very difficult to manage and compact. Practically speaking, these soils will be nearly impossible to handle and compact during wet weather conditions. Unless special provisions are considered in project plans and specifications along with time and budget allowance for use of these materials, we recommend that they not be considered for reuse as structural fill.

4.5. Fill Placement and Compaction

To obtain proper compaction, fill material should be compacted near optimum moisture content and in uniform horizontal lifts. The maximum allowable moisture content varies with the soil gradation and should be evaluated during construction. Lift thickness and compaction procedures will depend on the moisture content and gradation characteristics of the soil and the type of compaction equipment used. Compaction should be achieved by mechanical means. Generally, 12-inch-thick loose lifts are appropriate for steel-drum vibratory roller compaction equipment. During fill and backfill placement, regular testing of in-place density should be conducted to check that adequate compaction is being achieved.

Fill placed to raise site grades and materials under pavements and structural areas should be placed on subgrades prepared as previously recommended. Fill material placed below structures, including slab areas and footings must be compacted to at least 95 percent of the theoretical maximum dry density (MDD) per ASTM International (ASTM) D 1557. In paved areas, fill must be compacted to at least 95 percent of the MDD in the upper 2 feet below pavement subgrade. Fill placed below a depth of 2 feet from subgrade in paved areas must be compacted to at least 90 percent of the MDD.

Fill material placed in landscaping areas should be compacted to a firm condition that will support construction equipment, as necessary, typically around 85 to 90 percent of the MDD.

4.6. Shallow Foundations

4.6.1. General

We anticipate proposed structures can be adequately supported on shallow foundations and slabs-on-grade. We understand that portions of the existing building were designed to accommodate the expansion structure and new loads will be distributed on existing shallow foundations. Other portions of the expansion structure will be supported on newly constructed shallow foundations.

The upper soils observed in our explorations were variable and typically consisted of loose sand with variable silt content to soft to stiff sandy silt. Due to the variability in density and composition of shallow soils below foundations and the potential for excessive differential settlement, we recommend foundations for the proposed structures not bear directly on these soils. We recommend overexcavation of existing soils

and replacement with a bearing pad consisting of crushed rock structural fill as discussed in the section below.

4.6.2. Footing Bearing Surface Preparation

Our specific bearing surface preparation recommendations are as follows:

- Existing soils should be overexcavated at least 2 feet below footings and replaced with compacted structural fill. Structural fill should extend at least 2 feet laterally beyond the edges of the footings.
- If soft fine-grained soils are present, these soils should be overexcavated up to 5 feet to expose underlying granular soils (i.e., alluvium sand) and replaced with structural fill. Considerations to reduce this 5-foot excavation depth may be determined in the field and substituted with geotextiles, fabrics, and/or quarry spalls. Subgrade soils upon overexcavation should be observed and confirmed by GeoEngineers. Where practical, structural fill extending to granular soils should extend laterally beyond the edge of the footings a distance equal to the thickness of the fill or 2 feet, whichever is less.
- Soils at the base of overexcavations should be proof compacted to a uniformly firm and unyielding condition prior to placement of structural fill for the bearing pad.
- Structural fill used for backfilling overexcavations should consist of crushed rock as described in the “Fill Materials” of this report. Structural fill placed below foundations should be compacted to at least 95 percent of the theoretical MDD of the material as determined per ASTM D 1557.

Footing excavations should be performed using a smooth-edged bucket to limit bearing surface disturbance. The foundation bearing surface should be prepared as discussed above and then compacted as necessary to a firm, non-yielding condition. Loose or disturbed materials present at the base of footing excavations must be removed or compacted. If soft or otherwise unsuitable areas are revealed during evaluation that cannot be compacted to a stable and uniformly firm condition the following options may be considered: (1) unsuitable soils be moisture conditioned and recompacted; (2) unsuitable soils be overexcavated and replaced with compacted structural fill, as needed. Overexcavation should extend to soils that are firm enough such that backfilled structural fill can be adequately compacted. Organic debris or organic-rich soils, if encountered below foundations, should be completely removed.

Prepared foundation bearing surfaces should be evaluated by a GeoEngineers representative to confirm bearing surfaces have been prepared in accordance with our recommendations. Foundation bearing surfaces must not be exposed to standing water. If water pools in the base of the excavation, it should be removed before placing structural fill or reinforcing steel. During periods of wet weather, structural fill and concrete should be placed as soon as practical after preparation of the footing excavations. If footing excavations will be exposed to extended wet weather conditions, a lean concrete mat can be considered for subgrade protection.

4.6.3. Dimensions and Allowable Soil Bearing Pressure

Exterior footings should be established at least 18 inches below the lowest adjacent final grade. Interior footings can be founded a minimum of 12 inches below the top of the floor slab. Continuous column footings should have a minimum width of 18 inches. Isolated column footings should have a minimum width of 24 inches.

Based on our review of our 2004 Report, an allowable bearing pressure of 3,000 psf was recommended for design of the existing building and future expansion, assuming shallow foundations were constructed on a minimum 2-foot-thick bearing pad consisting of crushed rock structural fill. Provided new loads combined with loads from the existing structure do not result in an exceedance of the allowable bearing pressure, we expect the existing footings will provide adequate bearing support.

For design of new shallow foundations, we also recommend an allowable soil bearing pressure of 3,000 psf for design provided foundations are constructed as recommended above. This bearing pressure applies to the total of dead and long-term live loads and may be increased by one-third when considering total loads, including earthquake or wind loads. This is a net bearing pressure. The weight of the footing and overlying backfill can be ignored in calculating footing sizes.

4.6.4. Shallow Foundations Near Existing Improvements

We understand that there could be new shallow foundations for the expansion structure that are constructed near existing structural improvements such as shallow foundations for the existing structure.

Foundations constructed adjacent to existing foundations can induce additional loading (load influence) on soils below the foundations, which can result in bearing and settlement considerations. Additionally, excavation for shallow foundations near existing footings can result in undermining and loss of subgrade support below the existing footings. In general, ways to avoid this could include the addition of shallow drilled piers below the adjacent foundations. Other alternatives include foundation setbacks and developing a structural solution (i.e., “bridge”) to connect older and newer buildings.

We should review all new foundations (including loads, elevations, and sizes) that are planned constructed within about 10 feet or less of existing structural improvements to provide specific recommendations, as necessary.

4.6.5. Foundation Settlement

We estimate settlement of footings designed and constructed as recommended will be less than 1 inch, with differential settlements of less than ½ inch between comparably loaded isolated column footings or along 50 feet of continuous footing. Settlement is expected to occur rapidly as loads are applied. Settlements could be greater than estimated if loose/soft or disturbed soil such as soft silt is present beneath footings.

These estimates are based on footing loads proportioned using the recommended allowable bearing pressure above. We should be notified once foundation loads are available to review and revise our settlement estimate, if necessary.

4.6.6. Lateral Resistance

The ability of the soil to resist lateral loads is a function of frictional resistance, which can develop on the base of footings and slabs, and the passive resistance, which can develop on the face of below-grade elements of the structure as these elements tend to move into the soil. For footings founded in accordance with the recommendations presented above, the allowable frictional resistance on the base of the footing may be computed using a coefficient of friction of 0.35 applied to the vertical dead-load forces.

The allowable passive resistance on the face of the footing or other embedded foundation elements may be computed using an equivalent fluid density of 230 pounds per cubic foot (pcf) for undisturbed and firm site soils or structural fill extending out from the face of the foundation element a horizontal distance at least equal to 2.5 times the depth of the element.

These values include a factor of safety of about 1.5. The passive earth pressure and friction components may be combined provided the passive earth pressure component does not exceed two-thirds of the total. The passive earth pressure value is based on the assumptions that the adjacent grade is level and groundwater remains below the base of the footing throughout the year. The top foot of soil should be neglected when calculating passive lateral earth pressure unless the area adjacent to the foundation is covered with pavement or a slab-on-grade.

4.6.7. Foundation Drains

Based on the potential presence of granular structural fill overlying low-permeability silts below foundations, we expect there is the potential for accumulation of shallow perched groundwater, and as such, we recommend that perimeter foundation drains be considered. Perimeter foundation drains would help maintain bearing pressures provided, drier conditions around the structure during wetter times of the year, help reduce migration of water below the building slab, or if there was near-surface seepage from other means such as irrigation and landscaping.

We recommend perimeter footing drains be installed at the base of exterior footings and include cleanouts. Drains should be installed within a 12-inch-deep trench and consist of perforated pipe at least 4 inches in diameter placed on an approximate 3- to 4-inch-thick bed of drainage material. Perforated pipe should be surrounded by 5 to 6 inches of drainage material on the remaining sides enclosed in a non-woven geotextile fabric to prevent fine soil from migrating into the drain material. We recommend drainage pipe consist of heavy-wall solid pipe (SDR-35 polyvinyl chloride [PVC], or equal). We do not recommend using flexible tubing. The drainage pipe should be either machine-slotted or perforated over the lower 60-degree perimeter of the pipe. For slotted pipe, the slots should be a maximum of 1/8-inch wide with four slots per inch. Perforated pipe should have two rows of 1/2-inch diameter holes spaced 120 degrees apart and at 4 inches on center. Roof downspout and retaining wall drain lines should not be routed to footing or below-grade drain lines. The drainage material should consist of material recommended for wall and footing drains described in the “Retaining Structure Drainage” section of this report.

4.7. Slab-on-Grade Floors

Provided deleterious material is not present, the existing alluvium may remain in place below building slabs provided it can be proof compacted to a uniformly firm, dense, and unyielding condition. We recommend slab-on-grade floors be underlain by a minimum 8-inch-thick capillary break layer to provide a more uniform and consistent support across the building area and to reduce the potential for moisture migration into the slab. The capillary break material should consist of a well-graded sand and gravel, crushed rock (CSBC) or washed rock with a maximum particle size of 3/4 inch and less than 5 percent fines. The material should be placed as recommended in the “Fill Placement and Compaction” section of this report.

Provided slab subgrades are prepared as recommended, a modulus of subgrade reaction of 100 pounds per cubic inch (pci) can be used for designing building floor slabs. If slabs are supported on compacted structural fill, a higher value may be possible and should be further evaluated.

This value is for a 1-foot by 1-foot square plate. The modulus of subgrade reaction for a foundation varies based on its minimum width according to the following equation:

$$k_s = k_{s1}[(B+1)/2B]^2$$

Where k_s is the modulus of subgrade reaction, k_{s1} is the modulus of subgrade reaction for a 1-foot by 1-foot plate, and B is the minimum width or lateral dimension of the mat.

The exposed subgrade should be evaluated after site grading is complete. We recommend slab subgrades be evaluated by a GeoEngineers representative during construction. Disturbed areas should be compacted, if possible, or removed and replaced with compacted structural fill. In all cases, the exposed soil should be proof compacted to a firm and unyielding condition.

In our opinion, an underslab drainage system is not necessary. However, if dry slabs are required (e.g., where adhesives are used to anchor carpet or tile to slab), a waterproof liner may be placed as a vapor barrier below the slab.

Settlement for floor slabs designed and constructed as recommended is estimated to be less than $\frac{3}{4}$ inch for a floor load of 500 psf. We estimate that differential settlement of floor slabs will be $\frac{1}{2}$ inch or less over a span of 50 feet.

4.8. Retaining Walls and Below-Grade Structures

4.8.1. Design Parameters

We recommend the following lateral earth pressures be used for design of conventional retaining walls and below-grade structures. Our design pressures assume that the ground surface around the retaining structures will be level or near level. If drained design parameters are used, drainage systems must be included in the design in accordance with the recommendations presented in the “Retaining Structure Drainage” section below.

The active soil pressure condition assumes the wall is free to move laterally $0.001 H$, where H is the wall height. The at-rest condition is applicable where walls are restrained from movement. The above recommended lateral soil pressures do not include the effects of sloping backfill surfaces or surcharge loads, except as described. Overcompaction of fill placed directly behind retaining walls or below-grade structures must be avoided to limit lateral pressures placed on the wall. We recommend use of hand-operated compaction equipment and maximum 6-inch loose lift thickness when compacting fill within about 5 feet of retaining walls and below-grade structures.

- Active soil pressure may be estimated using an equivalent fluid density of 38 pcf for the drained condition.
- Active total soil and hydrostatic pressure may be estimated using an equivalent fluid density of 80 pcf for the undrained condition; this value includes hydrostatic pressures.
- At-rest soil pressure may be estimated using an equivalent fluid density of 58 pcf for the drained condition.
- At-rest total soil and hydrostatic pressure may be estimated using an equivalent fluid density of 89 pcf for the undrained condition; this value includes hydrostatic pressures.

- For seismic considerations, a uniform lateral pressure of $12 \cdot H$ psf (where H is the height of the retaining structure or the depth of a structure below ground surface) should be added to the lateral earth pressure.
- If sloping conditions are present above or below new walls, we should be contacted to provide updated recommendations.
- A traffic surcharge can be estimated should be included if vehicles are allowed to operate within a zone equal to the height of the retaining walls. This can be estimated with a uniform horizontal load of 80 psf, applied in addition to the pressures presented above, or by assuming an additional 2 feet of fill. This is based on a uniform surface load of 250 psf; other surface loads should be considered on a case-by-case basis.

Retaining wall foundations may be designed using the recommendations presented above for building foundation design. We estimate settlement of retaining structures will be similar to the values previously presented for structure foundations.

4.8.2. Retaining Structure Drainage

If retaining walls or below-grade structures are designed using drained parameters, a drainage system behind the structure must be included to collect water and prevent the buildup of hydrostatic pressure against the structure. We recommend the drainage system include a zone of free-draining backfill against the back of the wall to within about 12 to 18 inches from the top of the wall. This drainage layer can consist of either an 18-inch-thick horizontal layer of a graded drainage material such as WSDOT Specification 9-03.12(4) (Gravel Backfill for Drains) or a 12-inch-thick layer of pea gravel with a non-woven geotextile designed for soil separation placed between the pea-gravel and backfill. Drain boards or other prefabricated drainage systems can be used provided they can be adequately connected to an appropriate collection and discharge pipe system.

A perforated, rigid, smooth-walled drainpipe with a minimum diameter of 4 inches should be placed along the base of the structure within the free-draining backfill and extend for the entire wall length. The drainpipe should be metal or rigid PVC pipe and be sloped to drain by gravity. Discharge should be routed to appropriate discharge areas and to reduce erosion potential. Cleanouts should be provided to allow routine maintenance. Roof downspouts or other types of drainage systems must not be connected to retaining wall drain systems.

4.9. Infiltration Feasibility Assessment

4.9.1. General

We understand plans to manage stormwater at the site could include on-site infiltration, if feasible. On-site stormwater facilities will be designed in general accordance with the 2019 Ecology SWMMWW.

Per the SWMMWW, design infiltration rates can be determined using the Soil Grain Size Analysis Method only for sites underlain soils that are not glacially consolidated. Native near surface soils observed in our explorations consisted of alluvium, which are not glacially consolidated and therefore we expect that the Soil Grain Size Analysis Method is acceptable for infiltration rate determination at the project site.

We observed alluvium at the site to typically include interbedded layers of sand and silt at various depths and thicknesses. Based on our experience in similar soils and our laboratory test results, fine-grained soils

such as the silts observed at the site will have a very low infiltration rate. We estimate design rates on the order of practically zero to 0.35 inches per hour. In addition, the silts present at the site would generally be considered a limiting or impermeable layer in regard to infiltration capacity. Due to the presence of intermittent layers of low-permeability silts observed in our explorations (particularly within the upper 10 feet of the ground surface), the variation in thicknesses, and the interbedding, it is our opinion that on-site infiltration would not be considered practical for the project. If absolutely necessary to infiltrate, we should be consulted to discuss depths, locations, further in-situ and location-specific testing, and risks involved. It is likely that results from additional testing would not be much better than presented above.

4.10. Pavement Design

4.10.1. General Design Criteria

We understand asphalt concrete (AC) and/or Portland cement concrete (PCC) pavements may be used for the proposed improvements. We anticipate that pavements for the proposed improvements will include new parking areas, driveways, and sidewalks. Our recommended pavement sections provided below are based on our explorations and experience in the area.

The recommended pavement sections below may not be adequate for heavy construction traffic loads such as those imposed by concrete transit mixers or dump trucks. Additional pavement thickness may be necessary to prevent pavement damage during construction. The recommended sections assume final improvements surrounding the pavement areas will be designed and constructed such that stormwater or excess irrigation water from landscape areas does not accumulate below the pavement section or pond on pavement surfaces. If pavements in parking areas slope inward (toward the center of the parking area) full depth curbs or other measures should be used to prevent water from entering and ponding on the subgrade and within the base section.

4.10.2. Pavement Construction Considerations

Existing pavements, hardscaping, or other structural elements, if present, should be removed prior to placement of new pavement sections. Pavement subgrade should be prepared to a uniformly firm, dense, and unyielding condition as previously described. CSBC and subbase should be moisture conditioned to near optimum moisture content and compacted to at least 95 percent of the MDD (ASTM D 1577).

CSBC should conform to applicable sections of 4-04 and 9-03.9(3) of the WSDOT Standard Specifications. Subbase should conform to applicable sections of 4-02 "Gravel Base" and 9-03.10 "Aggregate Gravel for Base" of the WSDOT Standard Specifications. Hot mix asphalt should conform to applicable sections of 5-04, 9-02 and 9-03 of the WSDOT Standard Specifications. PCC mix design should conform with Section 5-05.3(1) of the WSDOT Standard Specifications. Aggregates for PCC should conform to applicable sections of 9-03.1 of the WSDOT Standard Specifications.

Some areas of pavement may exhibit fatigue cracking over time. Cracks in the pavement will allow water to infiltrate to the underlying base course, which could increase the amount of pavement damage caused by traffic loads. To prolong the effective life of the pavement, cracks should be sealed as soon as possible.

4.10.3. Asphalt Concrete Pavement Design

We provide recommended conventional AC pavement sections below.

4.10.3.1. Standard-Duty AC Pavement – Automobile Driveways and Parking Areas

- 2 inches of hot mix asphalt, class ½-inch, PG 58-22
- 4 inches of CSBC
- 6 inches of subbase consisting of select granular fill as previously described, to provide a uniform grading surface, to provide pavement support, to maintain drainage and to provide separation from finer grained subgrade soils
- Subgrade proof-compacted to a firm and unyielding condition or structural fill prepared in accordance with the “Subgrade Preparation and Protection” section of this report

4.10.3.2. Heavy-Duty AC Pavement –Areas Subject to Occasional Heavy Truck Traffic

- 3 inches of hot mix asphalt, class-½ inch, PG 58-22
- 6 inches of CSBC
- 12 inches of subbase consisting of select granular fill, previously described, to provide a uniform grading surface, to provide pavement support, to maintain drainage and to provide separation from subgrade soils
- Subgrade proof-compacted to a firm and unyielding condition or structural fill prepared in accordance with the “Subgrade Preparation and Protection” section of this report

4.10.4. Portland Cement Concrete

We understand PCC pavements will likely be used for sidewalk areas at the site and may also be considered for driveway and parking areas. We recommend concrete pavements in vehicular areas be jointed and that dowel bars be included at the joints to assist in load transfer. Dowels should not be included between exterior pavement slabs and interior pavement slabs to reduce the risk of cracking occurring due to differential settlements.

4.10.4.1. Sidewalk PCC Pavement – Pedestrian Areas Not Subjected to Vehicle Loading

- 4 inches (minimum) of PCC with a minimum 14-day flexural strength of 650 pounds per square inch (psi)
- 2 inches (minimum) of compacted CSTC
- Subgrade proof-compacted to a firm and unyielding condition or structural fill prepared in accordance with the “Subgrade Preparation and Protection” section of this report

4.10.4.2. Standard PCC Pavement– Automobile Driveways and Parking Areas

- 6 inches (minimum) of PCC with a minimum 14-day flexural strength of 650 psi
- 4 inches (minimum) of compacted CSBC
- 4 inches of subbase consisting of select granular fill to provide a uniform grading surface and pavement support, to maintain drainage and to provide separation from subgrade soils
- Subgrade proof-compacted to a firm and unyielding condition or structural fill prepared in accordance with the “Subgrade Preparation and Protection” section of this report

4.10.4.3. Heavy Duty PCC Pavement–Areas Subject to Heavy Truck Traffic

- 9 inches (minimum) of PCC with a minimum 14-day flexural strength of 650 psi

- 4 inches (minimum) of compacted CSBC
- 6 inches of subbase consisting of select granular fill to provide a uniform grading surface and pavement support, to maintain drainage and to provide separation from subgrade soils
- Subgrade proof-compacted to a firm and unyielding condition or structural fill prepared in accordance with the “Subgrade Preparation and Protection” section of this report

5.0 LIMITATIONS

We have prepared this report for the Coastal Pacific Food Distributors Freezer Expansion project in Puyallup, Washington. Coastal Pacific Food Distributors may distribute copies of this report to authorized agents and regulatory agencies as may be required for the project.

Within the limitations of scope, schedule and budget, our services have been executed in accordance with generally accepted practices for geotechnical engineering in this area at the time this report was prepared. The conclusions, recommendations, and opinions presented in this report are based on our professional knowledge, judgment, and experience. No warranty, express or implied, applies to the services or this report.

Please refer to Appendix C titled “Report Limitations and Guidelines for Use” for additional information pertaining to use of this report.

6.0 REFERENCES

ASCE 7-16, 2016, “Minimum Design Loads and Associated Criteria for Buildings and Other Structures.”

Boulanger, R.W. and Idriss, I.M., 2014, “CPT and SPT Based Liquefaction Triggering Procedures”, *University of California at David, College of Engineering, Department of Civil & Environmental Engineering, Center for Geotechnical Modeling*, Report No. UCD/CGM-14/01.

Cetin, K.O., Seed, R.B., Der Kiureghian, A., Tokimatsu, K., Harder, L.F., Kayen, R.E. and Moss, R.E.S., 2004, “Standard Penetration Test-Based Probabilistic and Deterministic Assessment of Seismic Soil Liquefaction Potential”, *ASCE Journal of Geotechnical and Geoenvironmental Engineering*, Volume 130, Issue 12.

International Code Council, 2018, “International Building Code.”

Ishihara, K. and Yoshimine, M., 1992, “Evaluation of Settlements in Sand Deposits Following Liquefaction During Earthquakes”, *Japanese Society of Soil Mechanics and Foundation Engineering, Soils and Foundations*, Volume 32, Number 1, pp. 173-188.

Schuster et al., 2015, “Geologic Map of the Tacoma 1:100,000-scale Quadrangle, Washington”.

Tokimatsu, K. and Seed, H.B., 1987, “Evaluation of Settlements in Sands Due to Earthquake Shaking”, *ASCE Journal of Geotechnical Engineering*, Volume 113, Issue 8.

Washington State Department of Ecology, July 2019, “Stormwater Management Manual for Western Washington.”

Washington State Department of Transportation, 2021, “Standard Specifications for Road, Bridge and Municipal Construction.”

Youd, T.L. and Idriss, I.M. (2001). “Liquefaction Resistance of Soils: Summary Report from the 1996 NCEER and 1998 NCEER/NSF Workshops on Evaluation of Liquefaction Resistance of Soils”, *ASCE Journal of Geotechnical and Geoenvironmental Engineering*, Volume 127, Issue 4.

DRAFT

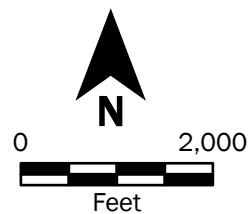
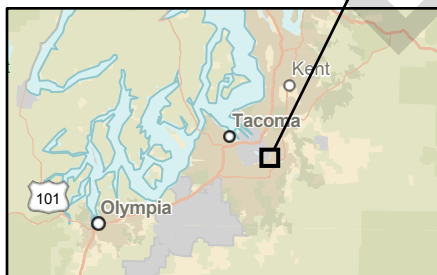
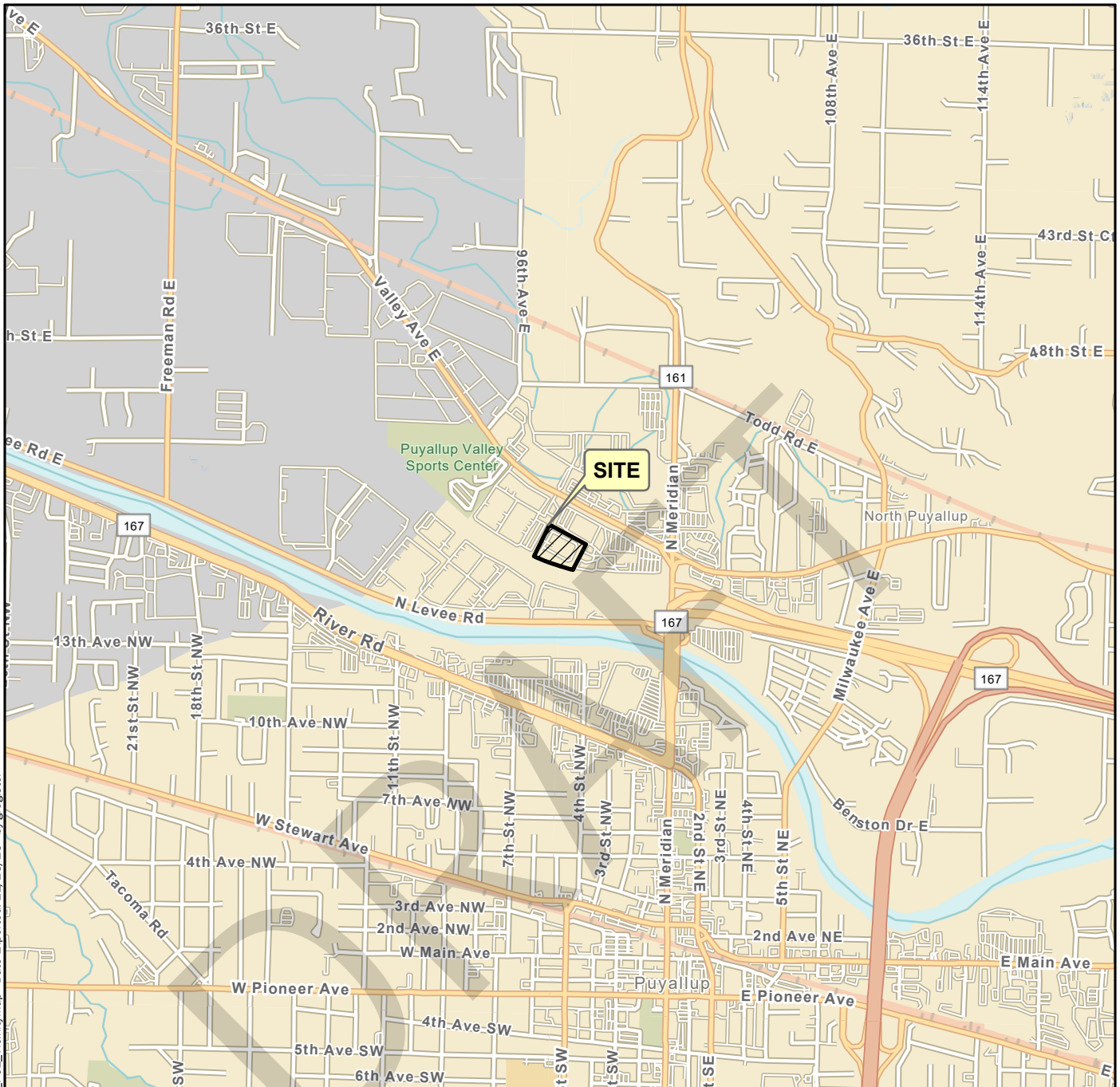

Source(s):
 • ESRI

Coordinate System: NAD 1983 StatePlane Washington South FIPS 4602 Feet

Disclaimer: This figure was created for a specific purpose and project. Any use of this figure for any other project or purpose shall be at the user's sole risk and without liability to GeoEngineers. The locations of features shown may be approximate. GeoEngineers makes no warranty or representation as to the accuracy, completeness, or suitability of the figure, or data contained therein. The file containing this figure is a copy of a master document, the original of which is retained by GeoEngineers and is the official document of record.

Vicinity Map

Coastal Pacific Food Distributors - Freezer Expansion
 Puyallup, Washington



Figure 1

P:\27\27044001\GIS\27044001_Project\27044001_L_Proyect.aprx\27044001_F01_VicinityMap Date Exported: 11/28/23 by gregster

P:\27\27044001\CAD\00_Geotech_Report\27044001_F02_Site_Plan.dwg 2 Date Exported:12/18/2023 5:43 PM - by Gabby Register



Legend

- Site Boundary
- GEI-1 Boring by GeoEngineers, Inc., 2023
- B-1 Boring by GeoEngineers, Inc., 2004
- C-1 Cone Penetration Test by GeoEngineers, 2004
- TP-1 Test Pit by GeoEngineers, Inc., 2004

Source(s):
• Aerial from Microsoft Bing Images

Projection: WA State Plane, South Zone, NAD83, US Foot

Disclaimer: This figure was created for a specific purpose and project. Any use of this figure for any other project or purpose shall be at the user's sole risk and without liability to GeoEngineers. The locations of features shown may be approximate. GeoEngineers makes no warranty or representation as to the accuracy, completeness, or suitability of the figure, or data contained therein. The file containing this figure is a copy of a master document, the original of which is retained by GeoEngineers and is the official document of record.

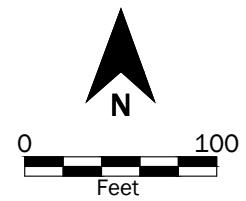

Site Plan	
Coastal Pacific Food Distributors - Freezer Expansion Puyallup, Washington	
	Figure 2

APPENDIX A
Subsurface Explorations and Laboratory Testing

DRAFT

APPENDIX A

SUBSURFACE EXPLORATIONS AND LABORATORY TESTING

Subsurface Explorations

Soil and groundwater conditions at the site were explored by advancing five drilled borings on November 15, 2023. Locations of the borings were determined via an electronic tablet with global positioning system (GPS) software and are shown in the Site Plan, Figure 2. Locations were selected to target the proposed development area but were constrained to some degree by existing site infrastructure, grading, vegetation, and underground utilities. The locations and elevations of the explorations should be considered approximate.

The borings were performed using truck-mounted drilling equipment provided and operated by Holocene Drilling, Inc. under subcontract to GeoEngineers. Borings were advanced using hollow-stem auger drilling methods and advanced to depths between approximately 11½ and 31½ feet below existing site grade (bgs). Boring GEI-1 was completed as a monitoring well after drilling. The other borings were backfilled by the driller in accordance with Washington State Department of Ecology requirements. Soil cuttings generated from the borings were placed in metal barrels and hauled off by the driller for off-site disposal.

During the exploration program our field representative continuously monitored the borings, obtained representative soil samples, classified the soils, maintained a detailed log of each exploration, and observed groundwater conditions. Soil samples were obtained from the borings using a 1.4-inch-inside-diameter split-barrel sampler driven into the soil using a 140-pound hammer free-falling a distance of 30 inches. The number of blows required to drive the sampler the last 12 inches or other indicated distance is recorded on the logs as the blow count. Our field representative made sample attempts at 2½- to 5-foot-depth intervals. Samples were retained in sealed plastic bags to prevent moisture loss. The soils were classified visually in general accordance with ASTM International (ASTM) D 2488 and Figure A-1, which includes a Key to the Exploration Logs. Summary logs of the explorations are included as Figures A-2 through A-6.

Laboratory Test Results

Soil samples obtained from the explorations were retained in sealed plastic bags to prevent moisture loss and transported to the GeoEngineers laboratory. Representative soil samples were selected for laboratory tests to evaluate the pertinent geotechnical engineering characteristics of the soils and to confirm our field classification. The following paragraphs provide a description of the tests performed.

Particle Size Gradation – Sieve Analysis (SA)

Sieve analyses were performed on selected samples in general accordance with ASTM D6913. This test method covers the quantitative determination of the distribution of particle sizes in soils. Typically, the distribution of particle sizes larger than 75 micrometers (µm) is determined by sieving. The results of the tests were used to verify field soil classifications and determine pertinent engineering characteristics. Figure A-7 presents the results of our sieve analyses.

Particle Size Gradation – Hydrometer Analysis (HA)

Hydrometer analyses were performed on selected samples in general accordance with ASTM Test Method D 7928. This test method covers the quantitative determination of the distribution of particle sizes in soils.

Typically, the distribution of particle sizes smaller than 75 µm is determined by a sedimentation process using a hydrometer. The hydrometer analysis alone determines the distribution of particle sizes smaller than 2 millimeters (mm). Figure A-7 includes the results of our hydrometer analyses.

Percent Fines (%F)

Selected samples were “washed” through the U.S. No. 200 sieve to estimate the relative percentages of coarse- and fine-grained particles in the soil. The percent passing value represents the percentage by weight of the sample finer than the U.S. No. 200 sieve (fines). Tests were conducted in general accordance with ASTM D 1140. Test results are presented on the exploration logs at the respective sample depths.

Moisture Content (MC)

The moisture content of selected samples was determined in general accordance with ASTM Test Method D 2216. The test results are used to aid in soil classification and correlation with other pertinent engineering soil properties. The results are presented on the test pit logs at the depth tested.

DRAFT

SOIL CLASSIFICATION CHART

MAJOR DIVISIONS			SYMBOLS		TYPICAL DESCRIPTIONS
			GRAPH	LETTER	
COARSE GRAINED SOILS	GRAVEL AND GRAVELLY SOILS	CLEAN GRAVELS <small>(LITTLE OR NO FINES)</small>		GW	WELL-GRADED GRAVELS, GRAVEL - SAND MIXTURES
		GRAVELS WITH FINES <small>(APPRECIABLE AMOUNT OF FINES)</small>		GP	POORLY-GRADED GRAVELS, GRAVEL - SAND MIXTURES
		GRAVELS WITH FINES <small>(APPRECIABLE AMOUNT OF FINES)</small>		GM	SILTY GRAVELS, GRAVEL - SAND - SILT MIXTURES
	SAND AND SANDY SOILS	CLEAN SANDS <small>(LITTLE OR NO FINES)</small>		SW	WELL-GRADED SANDS, GRAVELLY SANDS
		SANDS WITH FINES <small>(APPRECIABLE AMOUNT OF FINES)</small>		SP	POORLY-GRADED SANDS, GRAVELLY SAND
		SANDS WITH FINES <small>(APPRECIABLE AMOUNT OF FINES)</small>		SM	SILTY SANDS, SAND - SILT MIXTURES
FINE GRAINED SOILS	SILTS AND CLAYS	LIQUID LIMIT LESS THAN 50		ML	INORGANIC SILTS, ROCK FLOUR, CLAYEY SILTS WITH SLIGHT PLASTICITY
		LIQUID LIMIT LESS THAN 50		CL	INORGANIC CLAYS OF LOW TO MEDIUM PLASTICITY, GRAVELLY CLAYS, SANDY CLAYS, SILTY CLAYS, LEAN CLAYS
		LIQUID LIMIT LESS THAN 50		OL	ORGANIC SILTS AND ORGANIC SILTY CLAYS OF LOW PLASTICITY
	SILTS AND CLAYS	LIQUID LIMIT GREATER THAN 50		MH	INORGANIC SILTS, MICACEOUS OR DIATOMACEOUS SILTY SOILS
		LIQUID LIMIT GREATER THAN 50		CH	INORGANIC CLAYS OF HIGH PLASTICITY
		LIQUID LIMIT GREATER THAN 50		OH	ORGANIC CLAYS AND SILTS OF MEDIUM TO HIGH PLASTICITY
HIGHLY ORGANIC SOILS			PT	PEAT, HUMUS, SWAMP SOILS WITH HIGH ORGANIC CONTENTS	

NOTE: Multiple symbols are used to indicate borderline or dual soil classifications

Sampler Symbol Descriptions

	2.4-inch I.D. split barrel / Dames & Moore (D&M)
	Standard Penetration Test (SPT)
	Shelby tube
	Piston
	Direct-Push
	Bulk or grab
	Continuous Coring

Blowcount is recorded for driven samplers as the number of blows required to advance sampler 12 inches (or distance noted). See exploration log for hammer weight and drop.

"P" indicates sampler pushed using the weight of the drill rig.

"WOH" indicates sampler pushed using the weight of the hammer.

NOTE: The reader must refer to the discussion in the report text and the logs of explorations for a proper understanding of subsurface conditions. Descriptions on the logs apply only at the specific exploration locations and at the time the explorations were made; they are not warranted to be representative of subsurface conditions at other locations or times.

ADDITIONAL MATERIAL SYMBOLS

SYMBOLS		TYPICAL DESCRIPTIONS
GRAPH	LETTER	
	AC	Asphalt Concrete
	CC	Cement Concrete
	CR	Crushed Rock/ Quarry Spalls
	SOD	Sod/Forest Duff
	TS	Topsoil

Groundwater Contact



Measured groundwater level in exploration, well, or piezometer



Measured free product in well or piezometer

Graphic Log Contact

Distinct contact between soil strata

Approximate contact between soil strata

Material Description Contact

Contact between geologic units

Contact between soil of the same geologic unit

Laboratory / Field Tests

%F	Percent fines
%G	Percent gravel
AL	Atterberg limits
CA	Chemical analysis
CP	Laboratory compaction test
CS	Consolidation test
DD	Dry density
DS	Direct shear
HA	Hydrometer analysis
MC	Moisture content
MD	Moisture content and dry density
Mohs	Mohs hardness scale
OC	Organic content
PM	Permeability or hydraulic conductivity
PI	Plasticity index
PL	Point load test
PP	Pocket penetrometer
SA	Sieve analysis
TX	Triaxial compression
UC	Unconfined compression
UU	Unconsolidated undrained triaxial compression
VS	Vane shear

Sheen Classification

NS	No Visible Sheen
SS	Slight Sheen
MS	Moderate Sheen
HS	Heavy Sheen

Key to Exploration Logs

Start Drilled 11/15/2023	End 11/15/2023	Total Depth (ft) 31.5	Logged By Checked By AvD CJL	Driller Holocene Drilling, Inc.	Drilling Method Hollow-stem Auger
Hammer Data	Autohammer 140 (lbs) / 30 (in) Drop	Drilling Equipment Diedrich D-50 Turbo	DOE Well I.D.: BPQ 645 A 2-in well was installed on 11/15/2023 to a depth of 25 ft.		
Surface Elevation (ft) Vertical Datum	40 NAVD88	Top of Casing Elevation (ft)	Groundwater Date Measured 11/15/2023		
Easting (X) Northing (Y)	1192850 688140	Horizontal Datum WA State Plane South NAD83 (feet)	Depth to Water (ft) 16.70	Elevation (ft) 23.30	
Notes:					

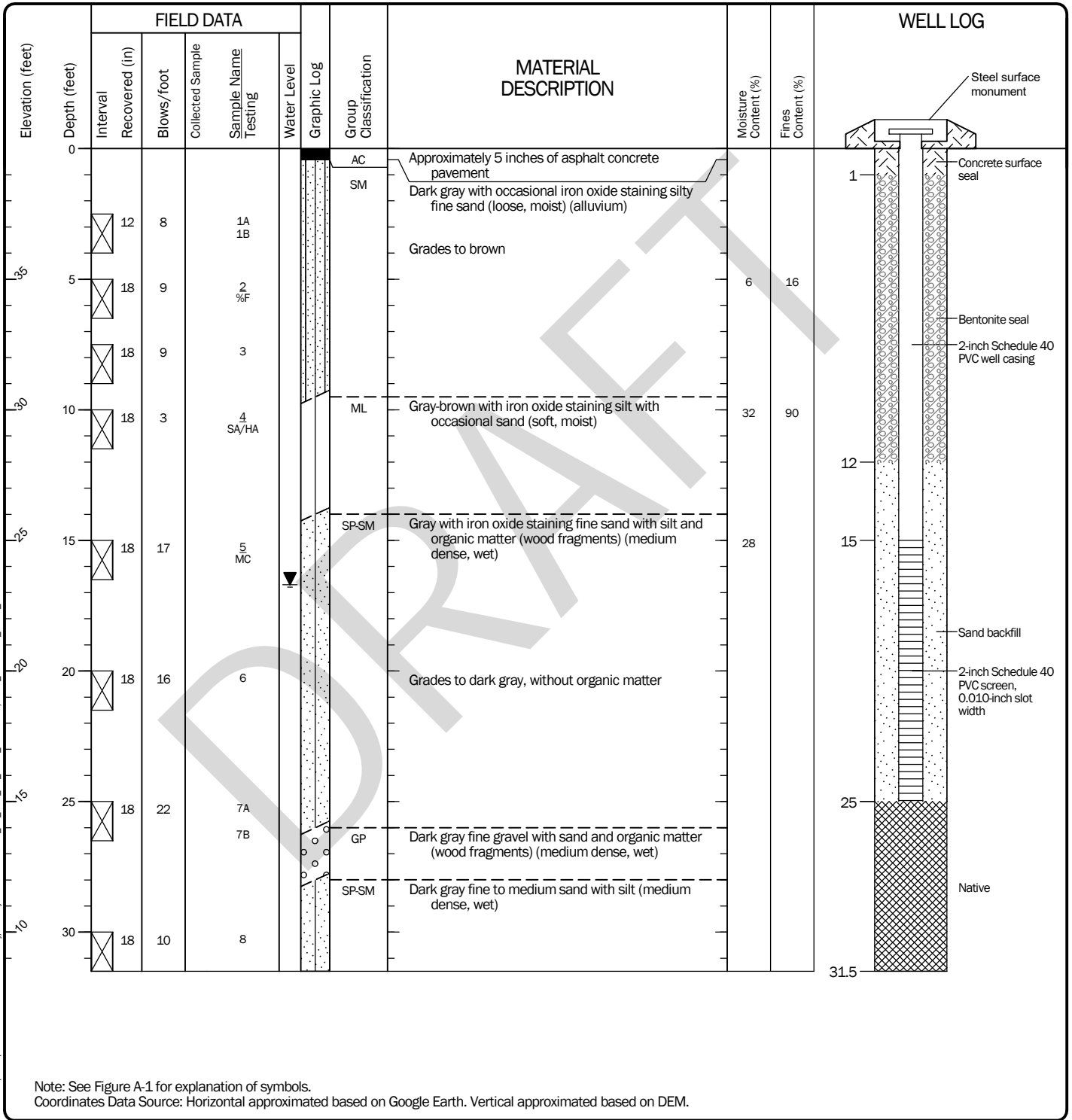

Log of Monitoring Well GEI-1



Project: Coastal Pacific Food Distributors Freezer Expansion
Project Location: Puyallup, Washington
Project Number: 27044-001-00

Start Drilled	11/15/2023	End	11/15/2023	Total Depth (ft)	11.5	Logged By	AvD	Checked By	CJL	Driller	Holocene Drilling, Inc.	Drilling Method	Hollow-stem Auger
Surface Elevation (ft) Vertical Datum	40 NAVD88			Hammer Data	Autohammer 140 (lbs) / 30 (in) Drop			Drilling Equipment	Diedrich D-50 Turbo				
Easting (X) Northing (Y)	1193010 688030			System Datum	WA State Plane South NAD83 (feet)			Groundwater not observed at time of exploration					
Notes:													

Elevation (feet)	FIELD DATA					Graphic Log	Group Classification	MATERIAL DESCRIPTION	Moisture Content (%)	Fines Content (%)	REMARKS
	Depth (feet)	Interval Recovered (in)	Blows/foot	Collected Sample	Sample Name Testing						
0						SOD	Approximately 8 inches of sod				
						ML	Brown sandy silt (medium stiff, moist) (alluvium)				
3.5	18	6		1	MC			23			
5	18	6		2			Grades with mottling and iron oxide staining				Interbedded silt and sand to 10 feet
	18	13		3	SA/HA		Grades to stiff	10	54		
10	18	8		4			Grades to medium stiff				Increased moisture content

DRAFT

Note: See Figure A-1 for explanation of symbols.
Coordinates Data Source: Horizontal approximated based on Google Earth. Vertical approximated based on DEM.

Log of Boring GEI-2



Project: Coastal Pacific Food Distributors Freezer Expansion
Project Location: Puyallup, Washington
Project Number: 27044-001-00

Figure A-3
Sheet 1 of 1

Date: 12/19/23 Path: P:\27_27044001\GINT\27044001\00.GPJ DBL\Library\Library\GEOENGINEERS_DF_STD_US_JUNE_2017.GLB\GEIS_GEO TECH_STANDARD_SF_NO_GW

Start Drilled	11/15/2023	End	11/15/2023	Total Depth (ft)	11.5	Logged By	AvD	Checked By	CJL	Driller	Holocene Drilling, Inc.	Drilling Method	Hollow-stem Auger
Surface Elevation (ft) Vertical Datum	41 NAVD88			Hammer Data	Autohammer 140 (lbs) / 30 (in) Drop			Drilling Equipment	Diedrich D-50 Turbo				
Easting (X) Northing (Y)	1193250 688000			System Datum	WA State Plane South NAD83 (feet)			Groundwater not observed at time of exploration					
Notes:													

Elevation (feet)	Depth (feet)	FIELD DATA				Graphic Log	Group Classification	MATERIAL DESCRIPTION	Moisture Content (%)	Fines Content (%)	REMARKS
		Interval Recovered (in)	Blows/foot	Collected Sample	Sample Name Testing						
0						SOD	Approximately 8 inches of sod				
						SM	Brown-gray with iron oxide staining silty fine to coarse sand (medium dense, moist)				
	18	10		1	MC			21			
	18	10		2						Interbedded layers of silt and sand to 10 feet	
	18	3		3	%F	ML	Brown-gray silt with sand (soft, moist)	25	78		
	18	6		4			Grades to medium stiff				

Note: See Figure A-1 for explanation of symbols.
Coordinates Data Source: Horizontal approximated based on Google Earth. Vertical approximated based on DEM.

Log of Boring GEI-3



Project: Coastal Pacific Food Distributors Freezer Expansion
Project Location: Puyallup, Washington
Project Number: 27044-001-00

Figure A-4
Sheet 1 of 1

Date: 12/19/23 Path: P:\27_27044\001\GINT\27044\001\00.GPJ DBL:library/Library\GEOENGINEERS_DF_STD_US_JUNE_2017.GLB\GEIS_GEO TECH_STANDARD_SF_NO_GW

Start Drilled	11/15/2023	End	11/15/2023	Total Depth (ft)	11.5	Logged By	AvD	Checked By	CJL	Driller	Holocene Drilling, Inc.	Drilling Method	Hollow-stem Auger
Surface Elevation (ft) Vertical Datum	42 NAVD88			Hammer Data	Autohammer 140 (lbs) / 30 (in) Drop			Drilling Equipment	Diedrich D-50 Turbo				
Easting (X) Northing (Y)	1193320 688110			System Datum	WA State Plane South NAD83 (feet)			Groundwater not observed at time of exploration					
Notes:													

Elevation (feet)	FIELD DATA					Graphic Log	Group Classification	MATERIAL DESCRIPTION	Moisture Content (%)	Fines Content (%)	REMARKS
	Depth (feet)	Interval Recovered (in)	Blows/foot	Collected Sample	Sample Name Testing						
0						SOD	Approximately 8 inches of sod				
30						ML	Orange-brown with iron oxide staining sandy silt with occasional organic matter (fine roots) (stiff, moist) (alluvium)	20			
5		18	10		1 MC						
		18	8		2 %F	SM	Brown silty fine sand with occasional organic matter (fine roots) (loose, moist)	12	48		
		18	6		3						
10		18	1		4		Grades to very loose				

Note: See Figure A-1 for explanation of symbols.
Coordinates Data Source: Horizontal approximated based on Google Earth. Vertical approximated based on DEM.

Log of Boring GEI-4



Project: Coastal Pacific Food Distributors Freezer Expansion
Project Location: Puyallup, Washington
Project Number: 27044-001-00

Figure A-5
Sheet 1 of 1

Date: 12/19/23 Path: P:\27_27044001\GINT\27044001\00.GPJ DBL\Library\Library\GEOENGINEERS_DF_STD_US_JUNE_2017.GLB\GEIS_GEO TECH_STANDARD_%F_NO_GW

Start Drilled	11/15/2023	End	11/15/2023	Total Depth (ft)	13	Logged By	AvD	Driller	Holocene Drilling, Inc.	Drilling Method	Hollow-stem Auger
Surface Elevation (ft) Vertical Datum	41 NAVD88			Hammer Data	Autohammer 140 (lbs) / 30 (in) Drop			Drilling Equipment	Diedrich D-50 Turbo		
Easting (X) Northing (Y)	1193160 688280			System Datum	WA State Plane South NAD83 (feet)			Groundwater not observed at time of exploration			
Notes:											

Elevation (feet)	FIELD DATA					MATERIAL DESCRIPTION	Moisture Content (%)	Fines Content (%)	REMARKS
	Depth (feet)	Interval Recovered (in)	Blows/foot	Collected Sample	Sample Name Testing				
0						AC			Approximately 5 inches of asphalt concrete pavement
						ML			Brown-gray with iron oxide staining silt with sand (stiff, moist) (alluvium)
	18	11		1A 1B		SM			Brown-gray with mottling and iron oxide staining, silty fine sand (medium dense, moist)
5	18	9		2 SA/HA		ML	15	65	Brown-gray sandy silt (stiff, moist)
		8		3					Grades to medium stiff
10	18	15		4		SM			Brown-gray silty fine sand (medium dense, moist)
	18	21		5 %F			24	48	

DRAFT

Note: See Figure A-1 for explanation of symbols.
Coordinates Data Source: Horizontal approximated based on Google Earth. Vertical approximated based on DEM.

Log of Boring GEI-5



Project: Coastal Pacific Food Distributors Freezer Expansion
Project Location: Puyallup, Washington
Project Number: 27044-001-00

Figure A-6
Sheet 1 of 1

Date: 12/19/23 Path: P:\27_27044001\GINT\27044001\00.GPJ DBL\Library\Library\GEOENGINEERS_DF_STD_US_JUNE_2017.GLB\GEIS_GEO TECH_STANDARD_%F_NO_GW

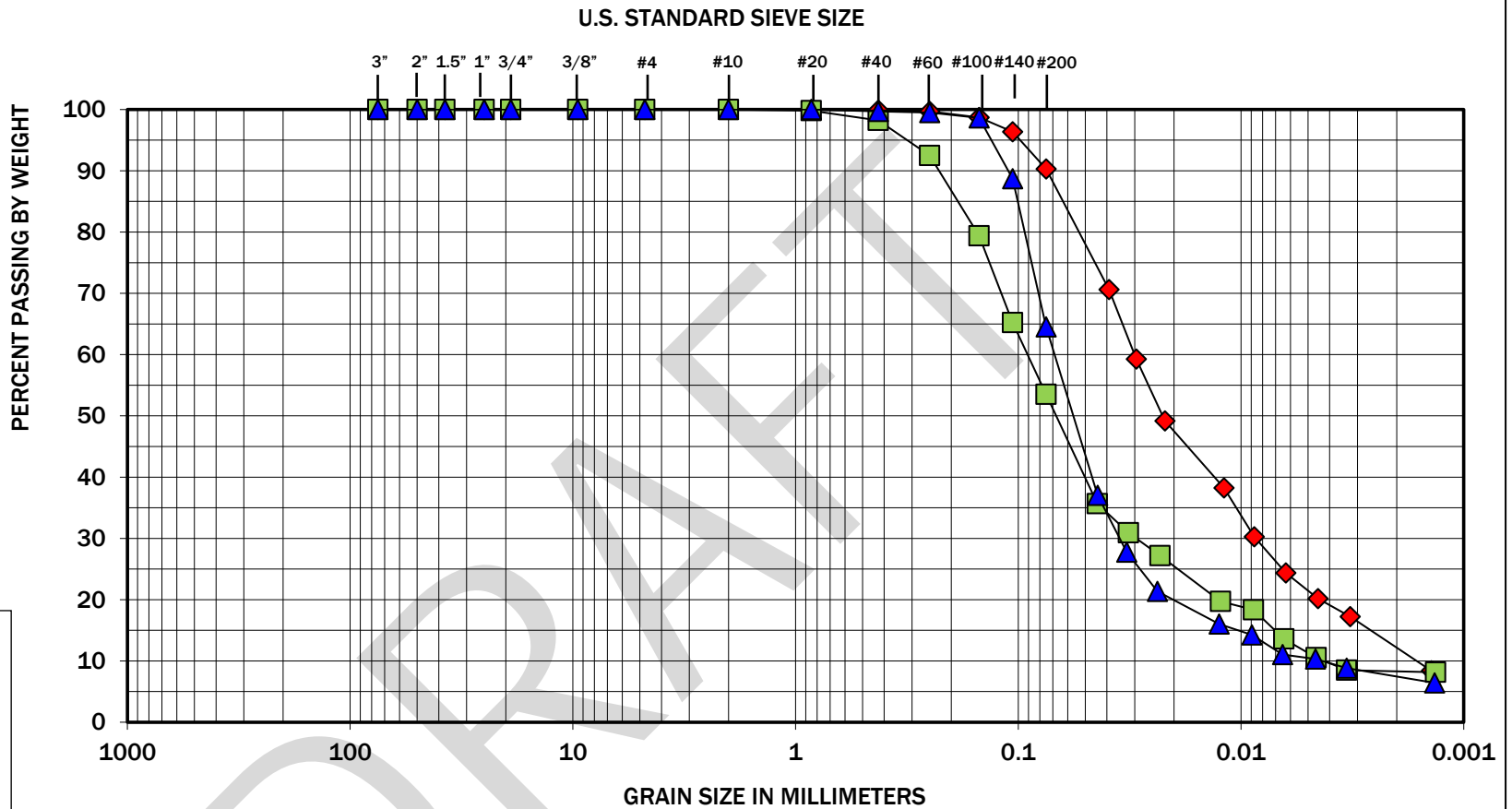

APPENDIX B
2004 Report Explorations

DRAFT

SOIL CLASSIFICATION CHART

MAJOR DIVISIONS			SYMBOLS		TYPICAL DESCRIPTIONS	
			GRAPH	LETTER		
COARSE GRAINED SOILS	GRAVEL AND GRAVELLY SOILS	CLEAN GRAVELS <small>(LITTLE OR NO FINES)</small>		GW	WELL-GRADED GRAVELS, GRAVEL - SAND MIXTURES	
		GRAVELS WITH FINES <small>(APPRECIABLE AMOUNT OF FINES)</small>		GP	POORLY-GRADED GRAVELS, GRAVEL - SAND MIXTURES	
	SAND AND SANDY SOILS	CLEAN SANDS <small>(LITTLE OR NO FINES)</small>		SW	WELL-GRADED SANDS, GRAVELLY SANDS	
		SANDS WITH FINES <small>(APPRECIABLE AMOUNT OF FINES)</small>		SP	POORLY-GRADED SANDS, GRAVELLY SAND	
		SILTS AND CLAYS	LIQUID LIMIT LESS THAN 50		ML	INORGANIC SILTS, ROCK FLOUR, CLAYEY SILTS WITH SLIGHT PLASTICITY
			LIQUID LIMIT GREATER THAN 50		CL	INORGANIC CLAYS OF LOW TO MEDIUM PLASTICITY, GRAVELLY CLAYS, SANDY CLAYS, SILTY CLAYS, LEAN CLAYS
SANDS WITH FINES <small>(APPRECIABLE AMOUNT OF FINES)</small>	LIQUID LIMIT LESS THAN 50		OL	ORGANIC SILTS AND ORGANIC SILTY CLAYS OF LOW PLASTICITY		
	LIQUID LIMIT GREATER THAN 50		MH	INORGANIC SILTS, MICACEOUS OR DIATOMACEOUS SILTY SOILS		
	LIQUID LIMIT GREATER THAN 50		CH	INORGANIC CLAYS OF HIGH PLASTICITY		
FINE GRAINED SOILS	SANDS WITH FINES <small>(APPRECIABLE AMOUNT OF FINES)</small>	LIQUID LIMIT GREATER THAN 50		OH	ORGANIC CLAYS AND SILTS OF MEDIUM TO HIGH PLASTICITY	
		LIQUID LIMIT GREATER THAN 50		PT	PEAT, HUMUS, SWAMP SOILS WITH HIGH ORGANIC CONTENTS	
HIGHLY ORGANIC SOILS				PT	PEAT, HUMUS, SWAMP SOILS WITH HIGH ORGANIC CONTENTS	

NOTE: Multiple symbols are used to indicate borderline or dual soil classifications

Sampler Symbol Descriptions

- 2.4-inch I.D. split barrel
- Standard Penetration Test (SPT)
- Shelby tube
- Piston
- Direct-Push
- Bulk or grab

Blowcount is recorded for driven samplers as the number of blows required to advance sampler 12 inches (or distance noted). See exploration log for hammer weight and drop.

A "P" indicates sampler pushed using the weight of the drill rig.

ADDITIONAL MATERIAL SYMBOLS

SYMBOLS		TYPICAL DESCRIPTIONS
GRAPH	LETTER	
	CC	Cement Concrete
	AC	Asphalt Concrete
	CR	Crushed Rock/ Quarry Spalls
	TS	Topsoil/ Forest Duff/Sod



Measured groundwater level in exploration, well, or piezometer



Groundwater observed at time of exploration



Perched water observed at time of exploration



Measured free product in well or piezometer

Stratigraphic Contact



Distinct contact between soil strata or geologic units



Gradual change between soil strata or geologic units



Approximate location of soil strata change within a geologic soil unit

Laboratory / Field Tests

- %F Percent fines
- AL Atterberg limits
- CA Chemical analysis
- CP Laboratory compaction test
- CS Consolidation test
- DS Direct shear
- HA Hydrometer analysis
- MC Moisture content
- MD Moisture content and dry density
- OC Organic content
- PM Permeability or hydraulic conductivity
- PP Pocket penetrometer
- SA Sieve analysis
- TX Triaxial compression
- UC Unconfined compression
- VS Vane shear

Sheen Classification

- NS No Visible Sheen
- SS Slight Sheen
- MS Moderate Sheen
- HS Heavy Sheen
- NT Not Tested

NOTE: The reader must refer to the discussion in the report text and the logs of explorations for a proper understanding of subsurface conditions. Descriptions on the logs apply only at the specific exploration locations and at the time the explorations were made; they are not warranted to be representative of subsurface conditions at other locations or times.

KEY TO EXPLORATION LOGS

Date(s) Drilled	08/06/04	Logged By	TCK	Checked By	TAD
Drilling Contractor	Holt Drilling	Drilling Method	Hollow-Stem Auger (HSA)	Sampling Methods	2.4-inch I.D. Split Spoon Ring Sampler
Auger/Bit Data	4-inch I.D. Continuous Flight	Hammer Data	300 (lb) hammer/ 30 (in) drop	Drilling Equipment	B-59 Foremost Mobile Drill Rig
Total Depth (ft)	30	Surface Elevation (ft)	39	Groundwater Elevation	22.5
Vertical Datum		Datum/System	N prop corner = Elevation 39.3	Easting(x): Northing(y):	

Depth feet	SAMPLES				Water Level	Graphic Log	Group Symbol	MATERIAL DESCRIPTION	Moisture Content %	Dry Unit Weight, lbs/ft ³	OTHER TESTS AND NOTES
	Interval	Recovered (in)	Blows/foot	Sub-Sample Sample Number							
0						SP	Brown fine to medium sand with occasional gravel (medium dense, moist) (fill)				
						SP	Brown fine to medium sand (medium dense, moist)				
5	18	21	1			SP	Gray fine to medium sand, trace silt (medium dense, moist)	8	91		
10	14	9	2			SM	Gray silty sand (medium dense, moist)				
15	12	12	3			ML	Gray sandy silt (medium stiff, moist to wet)	27		GS; %F=53	
20	14	15	4			SW-SM	Black-gray fine to coarse sand with silt, occasional wood chips and gravel (medium dense, wet)				
25	14	17	5			SP	Gray fine to medium sand, trace silt (medium dense, wet)				
30	6	24	6								
35											

Note: See Figure A-1 for explanation of symbols.

LOG OF BORING B-1



Project: Schwan Food Company
 Project Location: Puyallup, Washington
 Project Number: 11624-001-00

Figure: A-2
 Sheet 1 of 1

V6 GTSBORING P:111162400100FINAL\1162400100TP_B.GPJ GEIV6 1.GDT 8/18/04

Date(s) Drilled	08/06/04	Logged By	TCK	Checked By	TAD
Drilling Contractor	Holt Drilling	Drilling Method	Hollow-Stem Auger (HSA)	Sampling Methods	2.4-inch I.D. Split Spoon Ring Sampler
Auger/Bit Data	4-inch I.D. Continuous Flight	Hammer Data	300 (lb) hammer/ 30 (in) drop	Drilling Equipment	B-59 Foremost Mobile Drill Rig
Total Depth (ft)	50	Surface Elevation (ft)	38.4	Groundwater Elevation	22.4
Vertical Datum		Datum/System	N prop corner = Elevation 39.3	Easting(x): Northing(y):	

Depth feet	SAMPLES				Water Level	Graphic Log	Group Symbol	MATERIAL DESCRIPTION	Moisture Content %	Dry Unit Weight, lbs/ft ³	OTHER TESTS AND NOTES
	Interval	Recovered (in)	Blows/foot	Sub-Sample Sample Number							
0						SP-SM	Brown fine to medium sand with silt (loose, dry to moist)				
						ML	Brown-red mottled silt (medium stiff, moist)				
5	18	10	1			SM	Brown-red mottled silty sand (loose, moist)	10	88		
10	18	13	2			SP	Black-gray fine to medium sand (medium dense, moist)	4			GS; %F=2
15	12	13	3			SW	Red-brown fine to coarse sand, trace silt, occasional gravel (medium dense, moist to wet)				
20	6	25	4								
25	12	29	5			SP	Gray-black fine to medium sand, trace silt (medium dense, wet)				
30	14	23	6								
35	18	21	7			SM	Gray silty sand (medium dense, wet)				

Note: See Figure A-1 for explanation of symbols.

V6 GTBORING P:1111162400100FINAL51162400100TP B.GPJ GEIV6 1.GDT 8/18/04

LOG OF BORING B-2



Project: Schwan Food Company
 Project Location: Puyallup, Washington
 Project Number: 11624-001-00

Figure: A-3
 Sheet 1 of 2

Depth feet	SAMPLES				Water Level	Graphic Log	Group Symbol	MATERIAL DESCRIPTION	Moisture Content %	Dry Unit Weight, lbs/ft ³	OTHER TESTS AND NOTES
	Interval Recovered (in)	Blows/foot	Sub-Sample Sample Number								
35											
38	16	26	8			ML	Gray silt (very stiff, wet)				
40						SM	Gray silty sand (medium dense, wet)				
43	18	7	9			SM	Gray silty fine to coarse sand (loose, wet)	20		%F=26	
48	14	4	10								
50											
55											
60											
65											
70											
75											

DRAFT

V6_GTBORING_P\1111624001\00\FINALS\11624001\00\TP_B.BPJ GEI\6 1.GDT 8/18/04

LOG OF BORING B-2 (continued)



Project: Schwan Food Company
 Project Location: Puyallup, Washington
 Project Number: 11624-001-00

Figure: A-3
 Sheet 2 of 2

Date Excavated: 08/06/04

Logged by: TAD

Equipment: Case 580 Super L

Surface Elevation (ft): 38

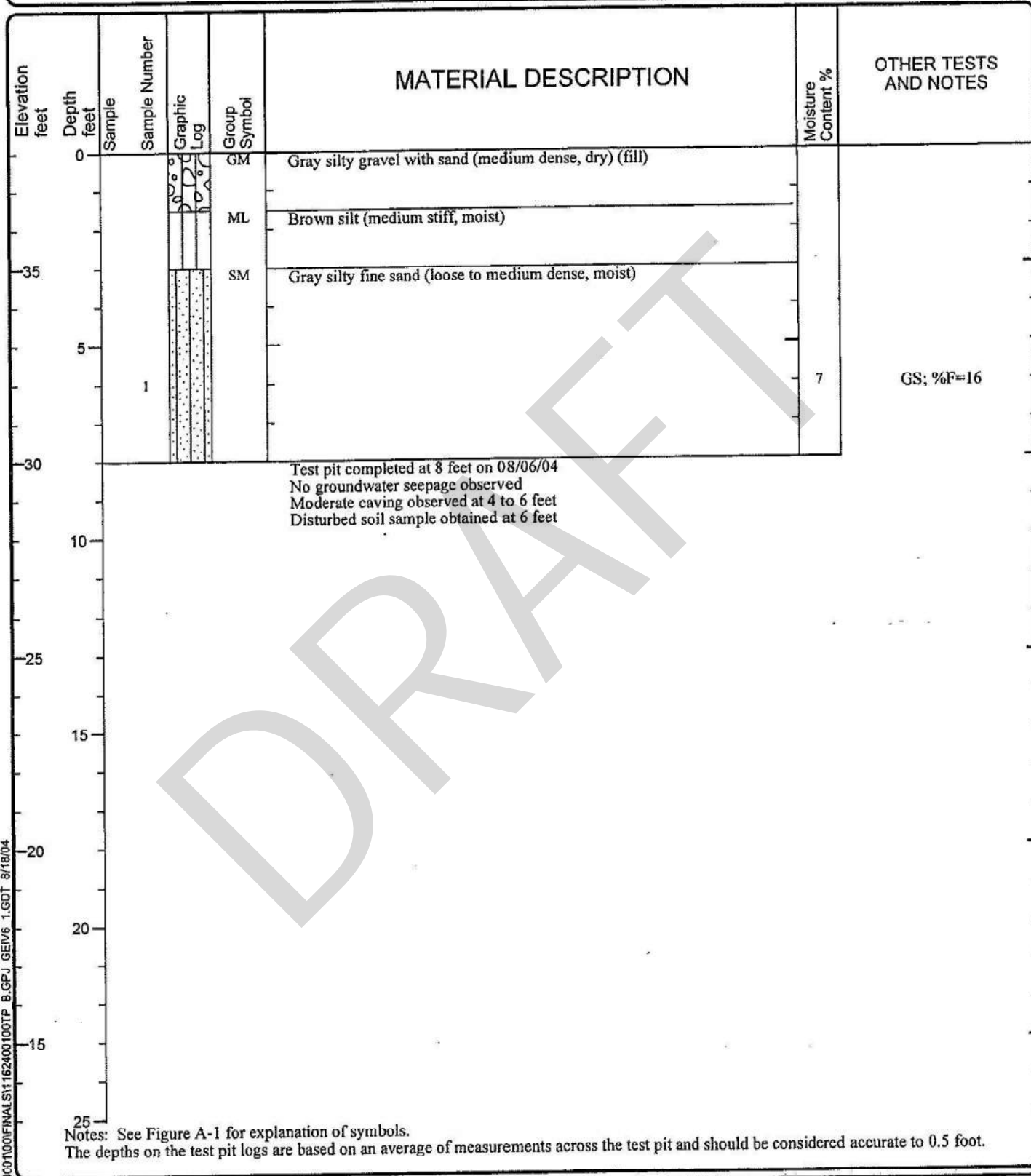

V6_GTPIT_P:1111624001000\FINALS\1162400100TP_B.GPJ_GEIV6_1.GDT_8/18/04

LOG OF TEST PIT TP-1



Project: Schwan Food Company
 Project Location: Puyallup, Washington
 Project Number: 11624-001-00

Figure: A-4
 Sheet 1 of 1

Date Excavated: 08/06/04

Logged by: TAD

Equipment: Case 580 Super L

Surface Elevation (ft): 37

Elevation feet	Depth feet	Sample Number	Graphic Log	Group Symbol	MATERIAL DESCRIPTION	Moisture Content %	OTHER TESTS AND NOTES
0				ML	Brown silt (medium stiff, dry)		
				ML	Gray-brown silt with fine sand (medium stiff, moist)		
35		1		SM	Gray-brown silty fine sand (medium dense, moist)	22	OC=1.1%; %F=64
5				ML	Gray-brown silt with wood fragments (medium stiff, moist)		pH
30		2		SM	Gray silty fine sand with wood fragments (medium dense, moist)		
10							
25							
					Test pit completed at 12 feet on 08/06/04 No groundwater seepage observed No caving observed Disturbed soil samples obtained at 3 and 9 feet		
15							
20							
15							
25							

Notes: See Figure A-1 for explanation of symbols.

The depths on the test pit logs are based on an average of measurements across the test pit and should be considered accurate to 0.5 foot.

LOG OF TEST PIT TP-2



Project: Schwan Food Company
 Project Location: Puyallup, Washington
 Project Number: 11624-001-00

Figure: A-5
 Sheet 1 of 1

Y6 GTTPIT P:111162400100FINAL1162400100TP_B.GPJ SEIV6 1.GDT 8/18/04

Date Excavated: 08/06/04

Logged by: TAD

Equipment: Case 580 Super L

Surface Elevation (ft): 37.9

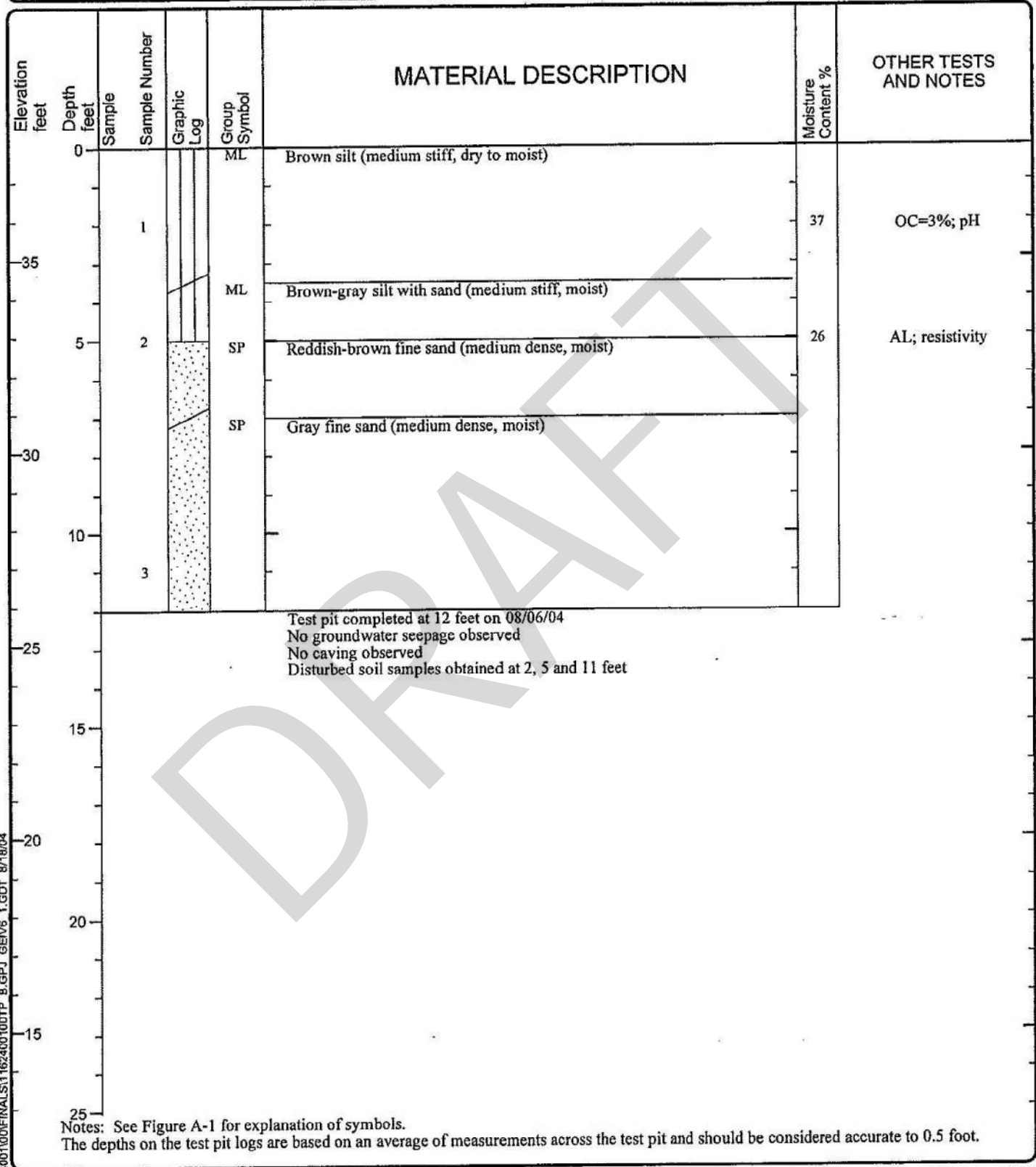

Notes: See Figure A-1 for explanation of symbols.

The depths on the test pit logs are based on an average of measurements across the test pit and should be considered accurate to 0.5 foot.

LOG OF TEST PIT TP-3



Project: Schwan Food Company
 Project Location: Puyallup, Washington
 Project Number: 11624-001-00

Figure: A-6
 Sheet 1 of 1

Y6 GTTPIT P:111162400100FINAL(S)162400100TP_B.GPJ_GEV6_1.GDT 8/18/04

Date Excavated: 08/06/04

Logged by: TAD

Equipment: Case 580 Super L

Surface Elevation (ft): 38.6

Elevation feet	Depth feet	Sample Number	Graphic Log	Group Symbol	MATERIAL DESCRIPTION	Moisture Content %	OTHER TESTS AND NOTES
0				ML	Brown silt (medium stiff, dry to moist)		
					Occasional wood fragments at 2 feet		
35							
	5	1		SP	Gray fine sand (loose, moist)	4	Resistivity; %F=3.5
30							
10					Test pit completed at 9 feet on 08/06/04 No groundwater seepage observed Moderate caving observed at 4.5 and 7 feet Disturbed soil sample obtained at 5 feet		
25							
15							
20							
20							
15							
25							

Notes: See Figure A-1 for explanation of symbols.
The depths on the test pit logs are based on an average of measurements across the test pit and should be considered accurate to 0.5 foot.

LOG OF TEST PIT TP-4



Project: Schwan Food Company
Project Location: Puyallup, Washington
Project Number: 11624-001-00

Figure: A-7
Sheet 1 of 1

V6_GTTPTP_P111162400100FINAL_S1162400100TP_B.GPJ GEI V6 1.GDT 8/18/04

Date Excavated: 08/06/04

Logged by: TAD

Equipment: Case 580 Super L

Surface Elevation (ft): 38.6

Elevation feet	Depth feet	Sample	Sample Number	Graphic Log	Group Symbol	MATERIAL DESCRIPTION	Moisture Content %	OTHER TESTS AND NOTES
0					ML	Brown sandy silt (medium stiff, dry to moist)		
35			1				24	%F=89
5			2		SP	Brown to gray-brown fine sand (medium dense, moist)		
						Grades to reddish-brown		
30					SP	Gray fine to medium sand (medium dense, moist)		
10					SP	Gray fine sand (medium dense, moist)		
						Test pit completed at 10.5 feet on 08/06/04 No groundwater seepage observed No caving observed Disturbed soil samples obtained at 4 and 6.5 feet		
25								
15								
20								
20								
15								
25								

Notes: See Figure A-1 for explanation of symbols.

The depths on the test pit logs are based on an average of measurements across the test pit and should be considered accurate to 0.5 foot.

LOG OF TEST PIT TP-5



Project: Schwan Food Company
 Project Location: Puyallup, Washington
 Project Number: 11624-001-00

Figure: A-8
 Sheet 1 of 1

V6_GTTPTT P:111162400100FINALST1162400100TP_B.GPJ_GEV6_1.GDT_8/18/04

U.S. STANDARD SIEVE SIZE

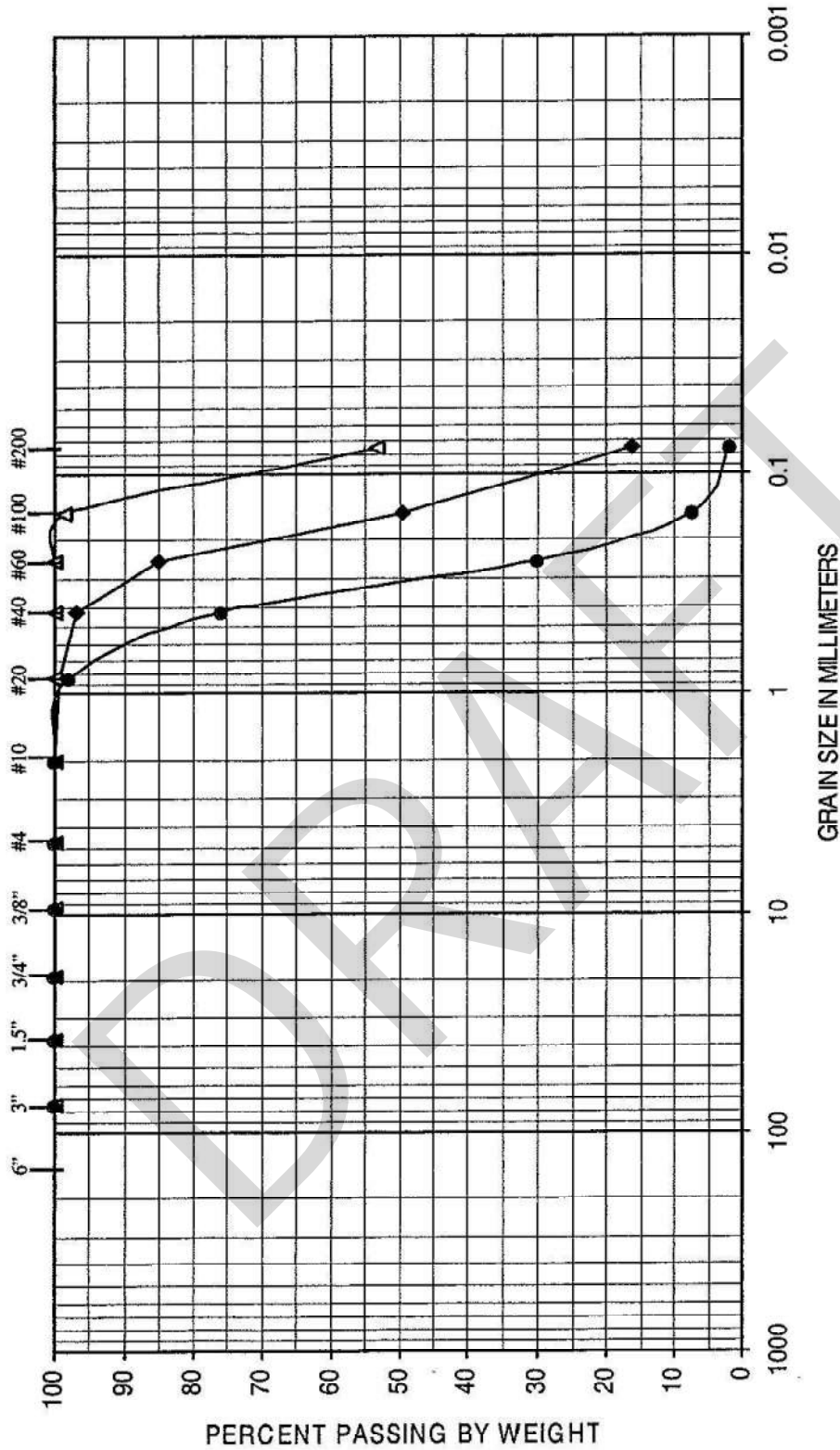

COBBLES	GRAVEL		SAND			SILT OR CLAY
	COARSE	FINE	COARSE	MEDIUM	FINE	

SYMBOL	BORING NUMBER	SAMPLE DEPTH (FEET)	SOIL CLASSIFICATION
◆	TP-1	6.0	Silty sand (SM)
△	B-1	14.5	Sandy silt (ML)
●	B-2	9.5	Fine to medium sand (SP)

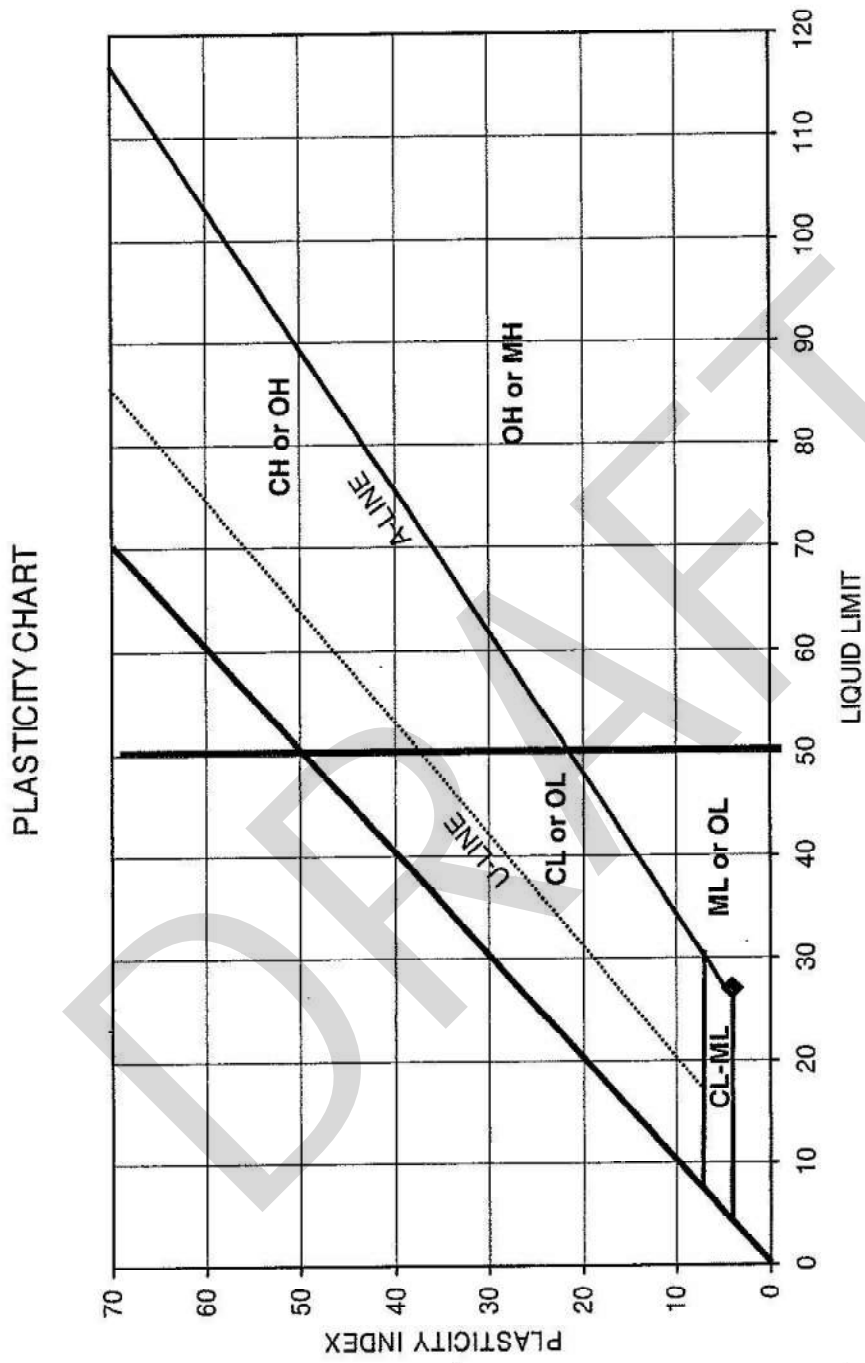

SYMBOL	EXPLORATION NUMBER	SAMPLE DEPTH	MOISTURE CONTENT (%)	LIQUID LIMIT (%)	PLASTICITY INDEX (%)	SOIL DESCRIPTION
◆	TP-3	5.0'	26	27	4	Brown silt w/sand (ML)

ATTACHMENT A
CPT LOGS BY NORTHWEST CONE, INC

DRAFT

Geo-Engineers

Operator: Nowak
 Sounding: CPT-1
 Cone Used: DSG0880

CPT Date/Time: 8/6/2004 8:41:51 AM
 Location: Schwan Food Company
 Job Number: 1162400100

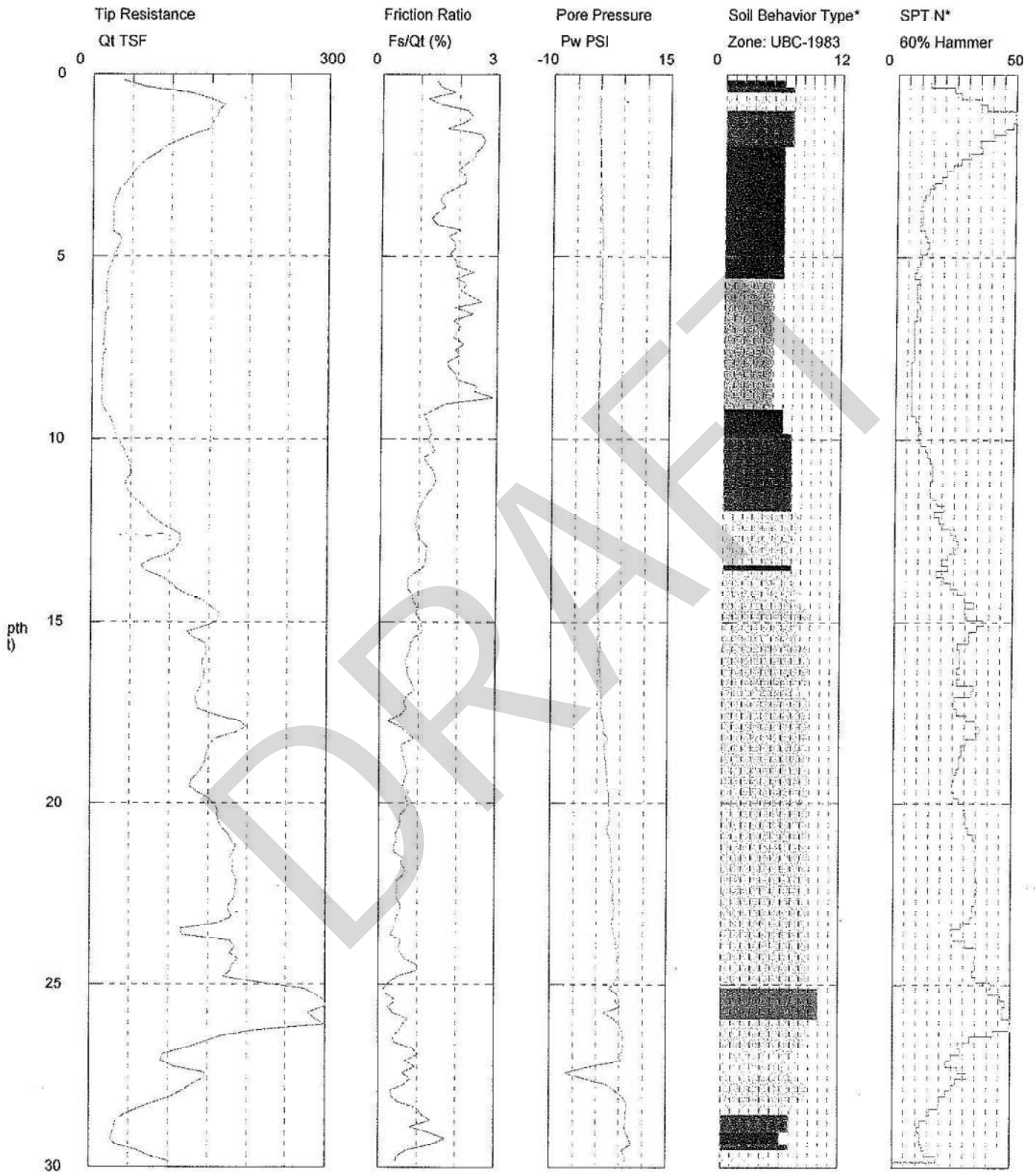

Maximum Depth = 30.18 feet

Depth Increment = 0.164 feet

- | | | | |
|--------------------------|-----------------------------|----------------------------|--------------------------------|
| 1 sensitive fine grained | 4 silty clay to clay | 7 silty sand to sandy silt | 10 gravelly sand to sand |
| 2 organic material | 5 clayey silt to silty clay | 8 sand to silty sand | 11 very stiff fine grained (*) |
| 3 clay | 6 sandy silt to clayey silt | 9 sand | 12 sand to clayey sand (*) |

behavior type and SPT based on data from UBC-1983

Geo-Engineers

Operator: Nowak
 Sounding: CPT-2
 Cone Used: DSG0880

CPT Date/Time: 8/6/2004 9:23:41 AM
 Location: Schwan Food Company
 Job Number: 1162400100

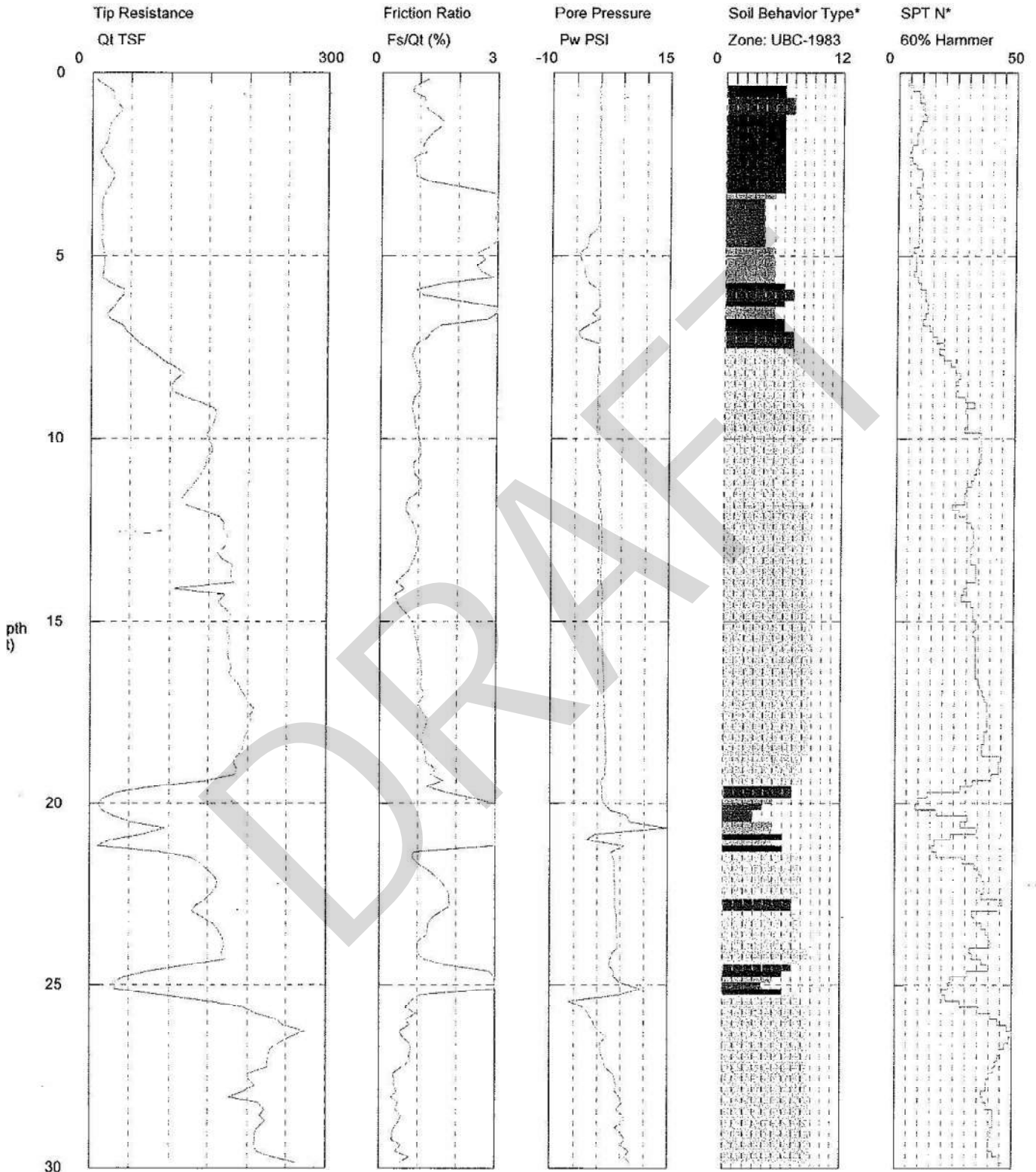

Maximum Depth = 30.51 feet

Depth Increment = 0.164 feet

- | | | | |
|--------------------------|-----------------------------|----------------------------|--------------------------------|
| 1 sensitive fine grained | 4 silty clay to clay | 7 silty sand to sandy silt | 10 gravelly sand to sand |
| 2 organic material | 5 clayey silt to silty clay | 8 sand to silty sand | 11 very stiff fine grained (*) |
| 3 clay | 6 sandy silt to clayey silt | 9 sand | 12 sand to clayey sand (*) |

behavior type and SPT based on data from UBC-1983

Geo-Engineers

Operator: Nowak
 Sounding: CPT-3
 Cone Used: DSG0880

CPT Date/Time: 8/6/2004 10:01:27 AM
 Location: Schwan Food Company
 Job Number: 1162400100

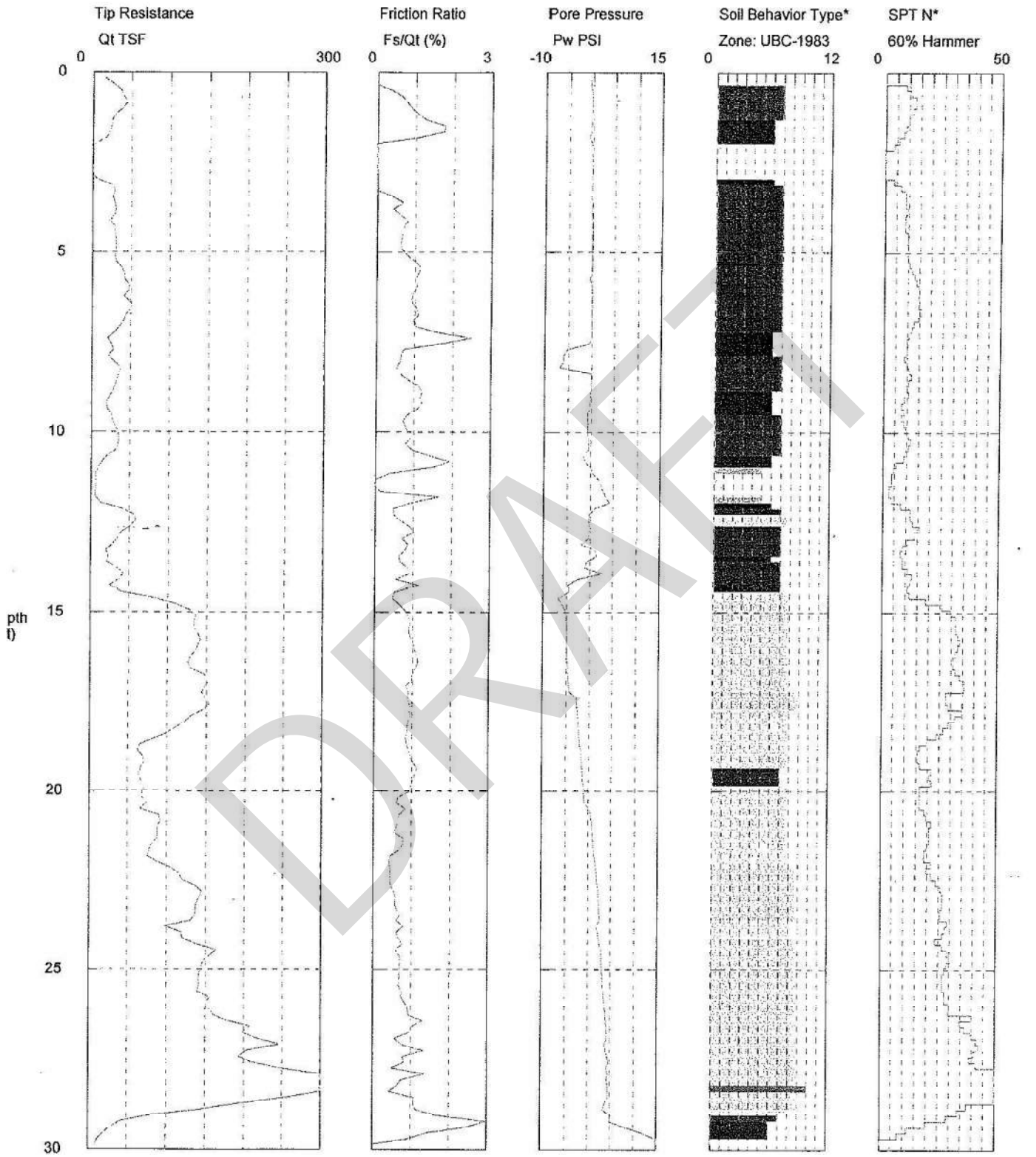

Maximum Depth = 30.02 feet

Depth Increment = 0.164 feet

- | | | | |
|--------------------------|-----------------------------|----------------------------|--------------------------------|
| 1 sensitive fine grained | 4 silty clay to clay | 7 silty sand to sandy silt | 10 gravelly sand to sand |
| 2 organic material | 5 clayey silt to silty clay | 8 sand to silty sand | 11 very stiff fine grained (*) |
| 3 clay | 6 sandy silt to clayey silt | 9 sand | 12 sand to clayey sand (*) |

behavior type and SPT based on data from UBC-1983

APPENDIX C
Report Limitations and Guidelines for Use

DRAFT

APPENDIX C REPORT LIMITATIONS AND GUIDELINES FOR USE¹

This appendix provides information to help you manage your risks with respect to the use of this report.

Read These Provisions Closely

It is important to recognize that the geoscience practices (geotechnical engineering, geology and environmental science) rely on professional judgment and opinion to a greater extent than other engineering and natural science disciplines, where more precise and/or readily observable data may exist. To help clients better understand how this difference pertains to our services, GeoEngineers includes the following explanatory “limitations” provisions in its reports. Please confer with GeoEngineers if you need to know more how these “Report Limitations and Guidelines for Use” apply to your project or site.

Geotechnical Services are Performed for Specific Purposes, Persons and Projects

This report has been prepared for Coastal Pacific Food Distributors and for the Project(s) specifically identified in the report. The information contained herein is not applicable to other sites or projects.

GeoEngineers structures its services to meet the specific needs of its clients. No party other than the party to whom this report is addressed may rely on the product of our services unless we agree to such reliance in advance and in writing. Within the limitations of the agreed scope of services for the Project, and its schedule and budget, our services have been executed in accordance with our Agreement with Coastal Pacific Food Distributors executed on October 3, 2023 and generally accepted geotechnical practices in this area at the time this report was prepared. We do not authorize, and will not be responsible for, the use of this report for any purposes or projects other than those identified in the report.

A Geotechnical Engineering or Geologic Report is based on a Unique Set of Project-Specific Factors

This report has been prepared for the Coastal Pacific Food Distributors Freezer Expansion project located in Puyallup, Washington. GeoEngineers considered a number of unique, project-specific factors when establishing the scope of services for this project and report. Unless GeoEngineers specifically indicates otherwise, it is important not to rely on this report if it was:

- Not prepared for you,
- Not prepared for your project,
- Not prepared for the specific site explored, or
- Completed before important project changes were made.

For example, changes that can affect the applicability of this report include those that affect:

- The function of the proposed structure;

¹ Developed based on material provided by GBA, GeoProfessional Business Association; www.geoprofessional.org.

- Elevation, configuration, location, orientation or weight of the proposed structure;
- Composition of the design team; or
- Project ownership.

If changes occur after the date of this report, GeoEngineers cannot be responsible for any consequences of such changes in relation to this report unless we have been given the opportunity to review our interpretations and recommendations. Based on that review, we can provide written modifications or confirmation, as appropriate.

Environmental Concerns are Not Covered

Unless environmental services were specifically included in our scope of services, this report does not provide any environmental findings, conclusions, or recommendations, including but not limited to, the likelihood of encountering underground storage tanks or regulated contaminants.

Information Provided by Others

GeoEngineers has relied upon certain data or information provided or compiled by others in the performance of our services. Although we use sources that we reasonably believe to be trustworthy, GeoEngineers cannot warrant or guarantee the accuracy or completeness of information provided or compiled by others.

Subsurface Conditions Can Change

This geotechnical or geologic report is based on conditions that existed at the time the study was performed. The findings and conclusions of this report may be affected by the passage of time, by man-made events such as construction on or adjacent to the site, new information or technology that becomes available subsequent to the report date, or by natural events such as floods, earthquakes, slope instability or groundwater fluctuations. If more than a few months have passed since issuance of our report or work product, or if any of the described events may have occurred, please contact GeoEngineers before applying this report for its intended purpose so that we may evaluate whether changed conditions affect the continued reliability or applicability of our conclusions and recommendations.

Geotechnical and Geologic Findings are Professional Opinions

Our interpretations of subsurface conditions are based on field observations from widely spaced sampling locations at the site. Site exploration identifies the specific subsurface conditions only at those points where subsurface tests are conducted or samples are taken. GeoEngineers reviewed field and laboratory data and then applied its professional judgment to render an informed opinion about subsurface conditions at other locations. Actual subsurface conditions may differ, sometimes significantly, from the opinions presented in this report. Our report, conclusions and interpretations are not a warranty of the actual subsurface conditions.

Geotechnical Engineering Report Recommendations are Not Final

We have developed the following recommendations based on data gathered from subsurface investigation(s). These investigations sample just a small percentage of a site to create a snapshot of the subsurface conditions elsewhere on the site. Such sampling on its own cannot provide a complete and accurate view of subsurface conditions for the entire site. Therefore, the recommendations included in this

report are preliminary and should not be considered final. GeoEngineers' recommendations can be finalized only by observing actual subsurface conditions revealed during construction. GeoEngineers cannot assume responsibility or liability for the recommendations in this report if we do not perform construction observation.

We recommend that you allow sufficient monitoring, testing and consultation during construction by GeoEngineers to confirm that the conditions encountered are consistent with those indicated by the explorations, to provide recommendations for design changes if the conditions revealed during the work differ from those anticipated, and to evaluate whether earthwork activities are completed in accordance with our recommendations. Retaining GeoEngineers for construction observation for this project is the most effective means of managing the risks associated with unanticipated conditions. If another party performs field observation and confirms our expectations, the other party must take full responsibility for both the observations and recommendations. Please note, however, that another party would lack our project-specific knowledge and resources.

A Geotechnical Engineering or Geologic Report Could Be Subject to Misinterpretation

Misinterpretation of this report by members of the design team or by contractors can result in costly problems. GeoEngineers can help reduce the risks of misinterpretation by conferring with appropriate members of the design team after submitting the report, reviewing pertinent elements of the design team's plans and specifications, participating in pre-bid and preconstruction conferences, and providing construction observation.

Do Not Redraw the Exploration Logs

Geotechnical engineers and geologists prepare final boring and testing logs based upon their interpretation of field logs and laboratory data. The logs included in a geotechnical engineering or geologic report should never be redrawn for inclusion in architectural or other design drawings. Photographic or electronic reproduction is acceptable, but separating logs from the report can create a risk of misinterpretation.

Give Contractors a Complete Report and Guidance

To help reduce the risk of problems associated with unanticipated subsurface conditions, GeoEngineers recommends giving contractors the complete geotechnical engineering or geologic report, including these "Report Limitations and Guidelines for Use." When providing the report, you should preface it with a clearly written letter of transmittal that:

- Advises contractors that the report was not prepared for purposes of bid development and that its accuracy is limited; and
- Encourages contractors to confer with GeoEngineers and/or to conduct additional study to obtain the specific types of information they need or prefer.

Contractors are Responsible for Site Safety on Their Own Construction Projects

Our geotechnical recommendations are not intended to direct the contractor's procedures, methods, schedule or management of the work site. The contractor is solely responsible for job site safety and for managing construction operations to minimize risks to on-site personnel and adjacent properties.

Biological Pollutants

GeoEngineers' Scope of Work specifically excludes the investigation, detection, prevention or assessment of the presence of Biological Pollutants. Accordingly, this report does not include any interpretations, recommendations, findings or conclusions regarding the detecting, assessing, preventing or abating of Biological Pollutants, and no conclusions or inferences should be drawn regarding Biological Pollutants as they may relate to this project. The term "Biological Pollutants" includes, but is not limited to, molds, fungi, spores, bacteria and viruses, and/or any of their byproducts.

A Client that desires these specialized services is advised to obtain them from a consultant who offers services in this specialized field.

DRAFT

Appendix C

Maintenance Report

- Attachment 1: City of Puyallup Private Stormwater Facility Maintenance
- Attachment 2: Biopod System Inspection & Maintenance Guide

2 Module 2: Private Stormwater Facility Maintenance

Module 2 of the SMP documents the City’s procedures for private stormwater facilities primarily on privately owned commercial property or on property owned by a Homeowners’ Association. These properties are generally maintained by a property management company, professional landscaper, contractor, or the property owner, and includes support from the City.

Information is presented by type of activity and includes many of the same activities as on municipal and residential properties (Modules 1 and 3, respectively, of this SMP). The information is intended to be referenced and used as applicable by private stormwater facility owners when performing O&M activities or related work. The information is not intended to be comprehensive; rather the SMP serves as a guidance document to help orient private stormwater facility owners to include the management of potential stormwater impacts during O&M activities. Each activity includes the same subsections as the other modules of the SMP for consistency, which are:

Problem/Need: what initiates the need for maintenance.

Relevant Activities: the operations and maintenance activities, both direct and ancillary, performed by property owners or site managers related to the O&M topic.

Frequency: the need for the activity, the motivating factor, how often the activity occurs.

Desired Results: the generally desired outcome of the activity, especially as it relates to stormwater management.

Resources: what special equipment, personnel, or coordination is needed for the activity.

Procedures: the key steps to performing the work.

Record-keeping & Documentation: what record-keeping is done to document the work. Puyallup City code requires maintenance and inspection reports for stormwater facilities on private property, and an Annual Inspection report form is included in Appendix D of this document for private stormwater facility inspection and maintenance reporting. City code [section 21.10.260 Inspection for Preventative Maintenance](#) contains a list of the necessary inspection reports, which shall be maintained by the City for all stormwater facilities on private property in accordance with the NPDES Permit section C5.C.7b(iii).

Best Management Practices and Maintenance Standards: what BMPs should be considered to manage stormwater and prevent pollution during the activity; options are provided from the Stormwater Management Manual for Western Washington (SWMMWW; Ecology, 2019), the King County Stormwater Pollution Prevention Manual (King County, 2021), and the Regional Road Maintenance Guidelines ESA Manual (Pierce County, 2002).

The O&M Standards for private stormwater facilities are provided in Appendix A and are listed alphabetically by topic. Links to the O&M Standards are available in the bookmarks of the PDF version of this document.

The following table summarizes the O&M activities and personnel that typically performs the activity.

PRIVATE FACILITIES

Module 2 Topics	Property Owner Maintenance Staff	Property Management Company	Professional Landscaper	Contractor	City Staff
1. Access and Inspection	X	A	A	A	S
2. Cleaning, Maintenance, and Repair of Aboveground BMPs	A	A	A	X	S
3. Cleaning, Maintenance, and Repair of Underground BMPs	A	A		X	S
4. Vegetation Maintenance and Chemical Applications	X	A	X		S
5. Animal and Solid Waste Management	X	A		X	S
6. Spill Control and Cleanup	X	A		A	S
7. Snow and Ice Control	X	A		A	S
8. Sediment and Erosion Control, Dewatering, and Flood Control	X	A	A	X	S
9. Asphalt and Concrete Pavement Repair, Resurfacing, and Cleaning	X			X	S
10. General Property Maintenance and Good Housekeeping	X	A	A	A	S

Notes:

X = primarily performed by

A = ancillary work

S = support or technical assistance

Appendix B contains source sheets for BMPs that are recommended for use in each O&M activity covered in Module 2. Table 2 lists these BMPs for Private Facilities, which are listed numerically by source and by volume, chapter, and BMP number (per each source). The BMP source sheets can be navigated via the links in each guidance sheet and the bookmarks in the PDF document navigation pane.

The information in the guidance sheets for the O&M topics can be updated with additional detail as needed or desired by the City over time. Such updates should serve to both further specify the practices and procedures and also to document the “what, where, and how” of O&M activities for consistency across Private Facilities. In this way, this SMP helps promote the shared responsibility with Private Facilities and the City’s municipal NPDES stormwater permit.

2.1 Access and Inspection

Problem/Need

Impeded access and/or access for regular inspection of stormwater structures, conveyances, and BMPs on private property.

Triggers include routine maintenance, citizen concerns/requests, physical inspections, weather, flooding, and observed conditions.

Relevant Activities

Done by:

- Property Owner Maintenance Staff

Ancillary work by:

- Property Management Company
- Professional Landscaper
- Contractor

Overlaps with:

- Cleaning, Maintenance, and Repair Aboveground BMPs
- Cleaning, Maintenance, and Repair Underground BMPs
- Vegetation Maintenance and Chemical Applications
- Snow and Ice Control
- General Property Maintenance and Good Housekeeping

Frequency

Routine:

- Annual inspections by the City in accordance with the Private Stormwater Inspection Program Document
- Routine inspections by the property owner
- Preventative maintenance
- Emergency access

Special:

- After large storm events or spills
- Post-inspection City access/maintenance request
- In response to citizen complaints

Desired Result

Unimpeded access to, and regular inspection of, stormwater structures, conveyances, and BMPs.

Inspection of stormwater utility assets on property are properly documented in an inspection report and/or maintenance standard checklist.

Resources

Special Equipment:

- Keys or combinations to locked areas
- Hi-beam spotlight
- Special keys to open vault lids
- Tape measure
- Catch Basin/Manhole hook
- Impact Drill with ½” Allen Impact Socket
- Sediment probe or other device to measure sediment depth
- Pick tools, hammer, and various wrenches
- Camera, phone, or device for taking pictures with time and date stamp and location tag
- Shovel, rake, or pitchfork
- Machete
- Confined space equipment, as applicable
- Approved Traffic Control Plan (TCP) if traffic is impacted in the public right-of-way
- Traffic cones, advanced warning signs, and flagging paddles, as needed
- PPE

Procedures

General steps:

- Rent special equipment for the day if needed
- Traffic Control as needed
- Confined Space entry, as applicable
- Perform inspection to document condition and any deficiencies
- Properly dispose of solid waste material and debris removed
- Clean work area, remove traffic control devices, as applicable
- Lock up any areas with restricted access
- Submit maintenance records and maintenance deficiency corrections to the City prior to January 30 for the previous year’s maintenance

Pre-planning activities:

- Scheduling
- Staff, equipment, and parts availability
- Review previous site/property records for maintenance “hot spots”
- Check for access issues
- Weather forecast
- Check if permit is needed, (i.e., TCP)
- Coordination with City on when maintenance activities are scheduled

Record-keeping and Documentation

Record-keeping for maintenance at private stormwater facilities should include the following:

Maintenance Log:

- Document maintenance activities and when they occurred.
- Document repairs and maintenance to facility in accordance with the approved stormwater site plan Photos are highly encouraged for documentation.
- Keep facility maintenance records for a period of at least 3 years and submit annual reports following requirements in the facility maintenance agreement and the Puyallup Municipal Code (PMC).

Inspection Annual Report (due to City by January 30; see form in Appendix D):

- Date of inspection
- Name of inspector
- Condition of:
 - Vegetation
 - Fences
 - Spillways
 - Embankments
 - Reservoir area
 - Outlet channels
 - Underground drainage
 - Sediment load
 - Dispersion devices
 - Permeable pavement
 - Green roof
 - Drainage structures
 - Any other item that could affect the proper function of stormwater facilities
- Description of needed maintenance

Operations and Maintenance (O&M) Manual for Site (if applicable)

- Keep a copy on site or within reasonable access to the site.
- The O&M Manual stays with the property and should be transferred to a new owner when the property is sold.

For more details, see PMC section [21.10.260](#) for Inspection for Preventative Maintenance, and PMC section [21.10.280](#) for Maintenance Responsibility.

The City maintains inspection records for all Private Stormwater Facility Inspections and tracks deficiencies and maintenance progress.

BMPs and Maintenance Standards

Reference BMPs to use for Access and Inspection are listed below (see Table 2 for links to BMPs in Appendix B).

Ecology SWMMWW

- Correcting Illicit Connections to Storm Drains, IV-1, S410
- Preventive Maintenance / Good Housekeeping, IV-1, S454
- Employee Training, IV-1, S456
- Inspections, IV-1, S457
- Record Keeping, IV-1, S458
- Maintenance of Public and Private Utility Corridors and Facilities, IV-3, S415
- Maintenance of Stormwater Drainage and Treatment Systems, IV-3, S417
- Parking and Storage of Vehicles and Equipment, IV-3, S42

The O&M Standards for private stormwater facilities are provided in Appendix A and are listed alphabetically by topic. Links to the O&M Standards are available in the bookmarks of the PDF version of this document.

2.2 Cleaning, Maintenance, and Repair of Aboveground BMPs

Problem/Need

Periodic and scheduled cleaning, routine maintenance, and repairs of BMPs that are aboveground. These include private structural stormwater facilities and BMPs that can be accessed and maintained from aboveground, such as ditches, detention/retention ponds, swales, wet ponds, infiltration ponds and other stormwater detention and treatment systems that are open to the atmosphere or not fully enclosed.

Includes earthwork repairs (grading, berm/dike repair, scour/erosion) and facility retrofit/rehabilitation. Also includes removal of vegetation (i.e., cattails) and sediment at stormwater ponds and swales.

Removal of sediment and solid waste from private storm systems.

Triggers include routine maintenance, citizen concerns/requests, physical inspections, weather, flooding, and observed conditions.

Relevant Activities

Done by:

- Contractor

Ancillary work by:

- Property Owner Maintenance Staff
- Property Management Company
- Professional Landscaper

Overlaps with:

- Access and Inspection
- Cleaning, Maintenance, and Repair of Underground BMPs
- Vegetation Maintenance and Chemical Applications
- Animal and Solid Waste Management
- Sediment and Erosion Control, Dewatering, and Flood Control
- General Property Maintenance and Good Housekeeping

Frequency

Routine:

- Routine inspections
- Preventative maintenance
- Emergency access

Special:

- After large storm events or spills
- City maintenance request
- In response to citizen complaints

Desired Result

Maintain treatment capacity at stormwater treatment facilities, ponds, and proprietary devices where treatment media or soil mixes are used.

Clean stormwater facilities, restore hydraulic capacity, and remove overgrown vegetation that prohibit routine maintenance and access.

Stormwater infrastructure and facilities are in accordance with O&M standards and free of deficiencies, as outlined in Appendix A and the Site's O&M Manual.

Resources

Special Equipment:

- Vactor truck
- Excavator with ditching bucket
- Dump truck or utility trailer
- Street sweeper
- Mower/line trimmer
- Pipe video camera/truck
- Jetting sprayer and accessories
- Pumps and hoses
- Hand tools (as listed in Section 2.1)
- ESC BMPs (silt socks, straw wattles, etc.)
- PPE

Procedures

General steps:

- Rent special equipment as needed
- Traffic Control as needed
- Install ESC BMPs as needed
- Contain vactored waste material
- Properly dispose of solid waste material
- Mowing/vegetation/debris removal
- Properly dispose of debris and vegetation
- Dewatering as needed
- Soil stabilization as needed
- Clean work area and remove traffic control devices and ESC BMPs, as applicable

Pre-planning activities:

- Obtain treatment media or soil mix to specification for facility
- Scheduling
- Staff, equipment, and parts availability
- Establish access
- Weather forecast
- Check if permit is needed, (i.e., TCP)
- Coordination with City on when maintenance activities are scheduled

Record-keeping and Documentation

Record-keeping for maintenance at private stormwater facilities should include the details provided under Section 2.1 *Access and Inspection* of this SMP. Records and documentation are required to be submitted to the City, which maintains inspection records for all Private Stormwater Facility Inspections and tracks deficiencies and maintenance progress.

BMPs and Maintenance Standards

Reference BMPs to use for Cleaning, Maintenance, and Repair of Aboveground BMPs are listed below (see Table 2 for links to BMPs in Appendix B).

Ecology SWMMWW

- Nets and Blankets, II-3.2, C122
- Plastic Covering, II-3.2, C123
- Material Delivery, Storage, and Containment, II-3.2, C153
- Riprap Channel Lining, II-3.3, C202
- Outlet protection, II-3.3, C209
- Inlet protection, II-3.3, C220
- Silt Fence, II-3.3, C233
- Straw Wattles, II-3.3, C235
- Maintenance of Public and Private Utility Corridors and Facilities, IV-3, S415
- Maintenance of Roadside Ditches, IV-3, S416
- Maintenance of Stormwater Drainage and Treatment Systems, IV-3, S417
- Dust Control at Disturbed Land Areas and Unpaved Roadways and Parking Lots, IV-4, S407
- Landscaping and Lawn/Vegetation Management, IV-4, S411
- Soil Erosion and Sediment Control at Industrial Sites, IV-4, S425
- Irrigation, IV-4, S450
- Mobile Fueling of Vehicles and Heavy Equipment, IV-6, S419
- Spills of Oil and Hazardous Substances, IV-6, S426
- Maintenance and Repair of Vehicles and Equipment, IV-7, S414
- Labeling Storm Drain Inlets on Your Property, IV-7, S442

King County Pollution Prevention Manual

- Cleaning or Washing of Tools and Equipment, 3.0, A-1
- Storage of Liquid Materials in Portable Containers, 3.0, A-3
- Storage of Contaminated Soils, 3.0, A-6
- Clearing and Grading for Small Construction Projects, 3.0, A-27
- Dust Control for Commercial Applications, 3.0, A-44

Regional Road Maintenance Guidelines ESA Manual

- Dewatering, no. 2.50 (p. B-231)
- Dust Control, no. 2.61 (p. B-233)
- Hand Seeding, no. 2.75 (p. B-235)
- Hydroseeding, no. 2.77 (p. B-237)
- Vactoring, no. 2.166 (p. B-239)

The O&M Standards for private stormwater facilities are provided in Appendix A and are listed alphabetically by topic. Links to the O&M Standards are available in the bookmarks of the PDF version of this document.

2.3 Cleaning, Maintenance, and Repair of Underground BMPs

Problem/Need

Periodic and scheduled cleaning, routine maintenance, and repairs of BMPs that are underground. These include private structural stormwater facilities and BMPs that are underground and accessed via a hatch, lid, or confined space entry. These include vaults, pipes, catch basins, manholes, dry wells, stormwater pump stations, and infiltration, detention/retention, and treatment facilities that are not open to the atmosphere or are fully enclosed.

Includes structural repairs (grouting, settlement repair, riser repair), cleaning, and structure replacement. Also includes sediment removal from vaults and other confined space structures.

Soil and treatment media removal and replacement at enclosed private stormwater treatment facilities and vaults.

Removal of sediment and solid waste from private storm systems.

Triggers include routine maintenance, citizen concerns/requests, physical inspections, weather, flooding, and observed conditions.

Relevant Activities

Done by:

- Contractor

Ancillary work by:

- Property Owner Maintenance Staff
- Property Management Company

Overlaps with:

- Access and Inspection
- Cleaning, Maintenance, and Repair of Aboveground BMPs
- Vegetation Maintenance and Chemical Applications
- Animal and Solid Waste Management
- Sediment and Erosion Control, Dewatering, and Flood Control
- General Property Maintenance and Good Housekeeping

Frequency

Routine:

- Routine inspections
- Preventative maintenance
- Emergency access
- Manufacturer-recommended maintenance

Special:

- After large storm events or spills
- City maintenance request
- In response to citizen complaints

Desired Result

Clean, maintain, and repair structural stormwater infrastructure and facilities to restore functionality as designed.

Cleanup of solid waste and sediment from structures underground and on property.

Removal of sediment in vaults and tanks.

Stormwater infrastructure and facilities are in accordance with O&M standards and free of deficiencies, as outlined in Appendix A and the Site's O&M Manual.

Resources

Special Equipment:

- Grader
- Backhoe
- Compactor
- Vactor truck
- Street sweeper
- Pipe video camera/truck
- Confined space entry equipment
- Jetting sprayer and accessories
- Pumps and hoses
- Hand tools
- ESC BMPs (silt socks, straw wattles, etc.)
- PPE

Procedures

General steps:

- Rent special equipment as needed
- Install ESC BMPs as needed
- Jetting and vactoring in sections
- Contain vactored waste material
- Removal and replacement of soil or media
- Properly dispose of solid waste material
- Mowing/vegetation/debris removal
- Properly dispose of debris and vegetation
- Compaction as specified
- Dewatering as needed
- Soil stabilization as needed
- Clean work area and remove traffic control devices and ESC BMPs, as applicable

Pre-planning activities:

- Obtain treatment media or soil mix to specification for facility
- Scheduling
- Staff, equipment, and parts availability
- Establish access
- Weather forecast
- Required Environmental permits (in-stream work only)
- Check if permit is needed, (i.e., TCP)
- Coordination with City on when maintenance activities are scheduled

Record-keeping and Documentation

Record-keeping for maintenance at private stormwater facilities should include the details provided under Section 2.1 *Access and Inspection* of this SMP. Records and documentation are required to be submitted to the City, which maintains inspection records for all Private Stormwater Facility Inspections and tracks deficiencies and maintenance progress.

BMPs and Maintenance Standards

Reference BMPs to use for Cleaning, Maintenance, and Repair of Underground BMPs are listed below (see Table 2 for links to BMPs in Appendix B).

Ecology SWMMWW

- Materials on Hand, II-3.2, C150
- Concrete Handling, II-3.2, C151
- Sawcutting and Surfacing Pollution Prevention, II-3.2, C152
- Material Delivery, Storage, and Containment, II-3.2, C153

- Concrete Washout Area, II-3.2, C154
- Outlet protection, II-3.3, C209
- Inlet protection, II-3.3, C220
- Straw Wattles, II-3.3, C235
- Treating and Disposing of High pH Water, II-3.3, C252
- Maintenance of Public and Private Utility Corridors and Facilities, IV-3, S415
- Maintenance of Stormwater Drainage and Treatment Systems, IV-3, S417
- Dust Control at Disturbed Land Areas and Unpaved Roadways and Parking Lots, IV-4, S407
- Soil Erosion and Sediment Control at Industrial Sites, IV-4, S425
- Storage or Transfer (Outside) of Solid Raw Materials, Byproducts, or Finished Products, IV-5, S429
- Mobile Fueling of Vehicles and Heavy Equipment, IV-6, S419
- Spills of Oil and Hazardous Substances, IV-6, S426
- Maintenance and Repair of Vehicles and Equipment, IV-7, S414
- Labeling Storm Drain Inlets on Your Property, IV-7, S442

King County Pollution Prevention Manual

- Storage of Contaminated Soils, 3.0, A-6
- Storage of Liquid Materials in Portable Containers, 3.0, A-3
- Cleaning or Washing of Tools and Equipment, 3.0, A-11
- Concrete and Asphalt Recycling, 3.0, A-19
- Concrete and Asphalt Application, 3.0, A-20
- Clearing and Grading for Small Construction Projects, 3.0, A-27
- Potable Water Line Flushing, Water Tank Maintenance and Hydrant Testing, 3.0, A-42
- Dust Control for Commercial Applications, 3.0, A-44

Regional Road Maintenance Guidelines ESA Manual

- Dewatering, no. 2.50 (p. B-231)
- Dust Control, no. 2.61 (p. B-233)
- Hand Seeding, no. 2.75 (p. B-235)
- Hydroseeding, no. 2.77 (p. B-237)
- Vactoring, no. 2.166 (p. B-239)

The O&M Standards for private stormwater facilities are provided in Appendix A and are listed alphabetically by topic. Links to the O&M Standards are available in the bookmarks of the PDF version of this document.

2.4 Vegetation Maintenance and Chemical Applications

Problem/Need

Trimming, mowing, removing, and generally maintaining vegetation on private property. This includes tree removal and hazard tree removal.

Regular application of fertilizers, pesticides, and herbicides for private property vegetation management.

Triggers include routine maintenance, citizen concerns/requests, physical inspections, weather, flooding, and observed conditions.

Relevant Activities

Done by:

- Property Owner Maintenance Staff
- Professional Landscaper

Ancillary work by:

- Property Management Company

Overlaps with:

- Access and Inspection
- Cleaning, Maintenance, and Repair of Aboveground BMPs
- Sediment and Erosion Control, Dewatering, and Flood Control
- General Property Maintenance and Good Housekeeping

Frequency

Routine:

- Routine inspections
- Preventative maintenance
- Seasonal leaf debris removal
- Emergency access
- All fertilizer, pesticide, and herbicide applications are dependent on weather conditions

Special:

- City maintenance request
- Hazard tree removal
- In response to citizen complaints

Desired Result

Health and aesthetics of property vegetation.

Vegetation is maintained alongside roadways and parking lots at a level where it does not impede or limit sight distance.

Control invasive and noxious weeds, pests, and poisonous or nuisance vegetation.

Resources

Special Equipment:

- Backhoe
- Bucket truck
- Chipper
- Line trimmers
- Mowers
- Chain saw
- Pole saw
- Hedge trimmers
- Backpack blower
- Handheld blower
- Backpack sprayers
- Herbicide and pesticide liquid material
- Fertilizer liquid material
- Spill kit
- Hand tools
- ESC BMPs (silt socks, straw wattles, etc.)
- PPE

Procedures

General steps:

- Rent special equipment as needed
- Mowing/vegetation/debris removal
- Clearing and grubbing, as needed
- Properly dispose of debris and vegetation

ASPECT CONSULTING

- Apply fertilizer, pesticide, and/or herbicide according to WSDA protocols, training, and the instructions for their use, including reducing nutrients and pesticides using alternatives that minimize environmental impacts
- Soil stabilization and erosion control as needed
- Clean work area, as applicable

Refer to the City of Puyallup's Integrated Pest Management Plan in Appendix C of this document for detailed guidance on pest management.

Pre-planning activities:

- Training and licensing for fertilizer, pesticide, and/or herbicide applicators
- Develop an Integrated Pest Management Plan (IPMP)
- Scheduling
- Safety data sheets (SDS) for pesticides, herbicides, and fertilizers
- Staff, equipment, and parts availability
- Establish access
- Weather forecast
- Required Environmental permits (in-stream work only)

Record-keeping and Documentation

Record-keeping for maintenance at private stormwater facilities should include the details provided under Section 2.1 *Access and Inspection* of this SMP. Records and documentation are required to be submitted to the City, which maintains inspection records for all Private Stormwater Facility Inspections and tracks deficiencies and maintenance progress.

For record-keeping related to chemical applications to vegetation (e.g., pesticides, herbicides), refer to the BMPs below on chemical application, pesticides, pest management, and fertilizer application. The City's Integrated Pest Management plan is provided in Appendix C.

BMPs and Maintenance Standards

Reference BMPs to use for Vegetation Maintenance and Chemical Applications are listed below (see Table 2 for links to BMPs in Appendix B).

Ecology SWMMWW

- Material Delivery, Storage, and Containment, II-3.2, C153
- Outlet protection, II-3.3, C209
- Inlet protection, II-3.3, C220
- Straw Wattles, II-3.3, C235
- Spill Prevention and Cleanup, IV-1, S455
- Maintenance of Public and Private Utility Corridors and Facilities, IV-3, S415
- Maintenance of Roadside Ditches, IV-3, S416

- Maintenance of Stormwater Drainage and Treatment Systems, IV-3, S417
- Landscaping and Lawn/Vegetation Management, IV-4, S411
- Pesticides and an Integrated Pest Management Program, IV-4, S435
- Storage of Dry Pesticides and Fertilizer, IV-4, S444
- Irrigation, IV-4, S450
- Storage of Liquids in Permanent Aboveground Tanks, IV-5, S428
- Mobile Fueling of Vehicles and Heavy Equipment, IV-6, S419
- Spills of Oil and Hazardous Substances, IV-6, S426
- Fertilizer Application, IV-7, S443

King County Pollution Prevention Manual

- Storage of Liquid Materials in Portable Containers, 3.0, A-3
- Cleaning or Washing of Tools and Equipment, 3.0, A-11
- Chemical Application, 3.0, A-25
- Clearing and Grading for Small Construction Projects, 3.0, A-27
- Nurseries and Greenhouses, 3.0, A-49

Regional Road Maintenance Guidelines ESA Manual

- Hand Seeding, no. 2.75 (p. B-235)
- Hydroseeding, no. 2.77 (p. B-237)

The O&M Standards for private stormwater facilities are provided in Appendix A and are listed alphabetically by topic. Links to the O&M Standards are available in the bookmarks of the PDF version of this document.

2.5 Animal and Solid Waste Management

Problem/Need

Removal of animal waste and solid waste from private storm systems.

Includes disposal of sediment and solid waste from stormwater system cleaning.

Regular cleanup of trash, trash enclosures, garbage compactors, grease containers, recycling containers, and pet waste within private property.

Triggers include observed field conditions, weather, citizen concerns/requests, and routine maintenance.

Relevant Activities

Done by:

- Property Owner Maintenance Staff
- Contractor

Ancillary work by:

- Property Management Company

Overlaps with:

- Cleaning, Maintenance, and Repair of Aboveground BMPs
- Cleaning, Maintenance, and Repair of Underground BMPs
- Vegetation Maintenance and Chemical Applications
- Spill Control and Cleanup
- Sediment and Erosion Control, Dewatering, and Flood Control
- General Property Maintenance and Good Housekeeping

Frequency

Routine:

- Routine inspections
- Preventative maintenance
- Emergency access

Special:

- After large storm events
- After garbage service pickup

- After stormwater system cleaning
- City maintenance request
- In response to citizen complaints

Desired Result

Proper disposal of sediment and waste from storm system cleaning operations.

Litter-free and pet waste-free property.

Clean garbage enclosures and leak-free containers.

Resources

Special Equipment:

- Vactor truck
- Street sweeper
- Trash pickers
- Sharps containers
- Pet waste collection bags
- Pressure washer
- PPE

Procedures

General steps:

- Rent equipment as needed
- Sweeping or vactoring
- Collect trash and bring to dumpster on property
- Clean garbage enclosure area and dispose of waste properly
- Check containers for leaks and overflow
- Waste is hauled away by trash collection service or hauled to an approved disposal location

Pre-planning activities include:

- Scheduling
- Staff, equipment, and parts availability
- Establish access
- Weather forecast

Record-keeping and Documentation

Record-keeping for maintenance at private stormwater facilities should include the details provided under Section 2.1 *Access and Inspection* of this SMP. Records and

documentation are required to be submitted to the City, which maintains inspection records for all Private Stormwater Facility Inspections and tracks deficiencies and maintenance progress.

BMPs and Maintenance Standards

Reference BMPs to use for Animal and Solid Waste Management are listed below (see Table 2 for links to BMPs in Appendix B).

Ecology SWMMWW

- Material Delivery, Storage, and Containment, II-3.2, C153
- Outlet protection, II-3.3, C209
- Inlet protection, II-3.3, C220
- Storage of Liquid, Food Waste, or Dangerous Waste Containers, IV-5, S427
- Storage of Liquids in Permanent Aboveground Tanks, IV-5, S428
- Storage or Transfer (Outside) of Solid Raw Materials, Byproducts, or Finished Products, IV-5, S429
- Loading and Unloading Areas for Liquid or Solid Material, IV-6, S412
- Commercial Animal Handling Areas, IV-7, S402
- Commercial Composting, IV-7, S403
- Commercial Printing Operations, IV-7, S404
- Recyclers and Scrap Yards, IV-7, S423
- Pet Waste, IV-7, S440
- Goose Waste, IV-7, S452

King County Pollution Prevention Manual

- Storage of Contaminated Soils, 3.0, A-6
- Concrete and Asphalt Production and Recycling, 3.0, A-19
- Animal Waste, 3.0, A-34
- Keeping Livestock, 3.0, A-35

Regional Road Maintenance Guidelines ESA Manual

- Vactoring, no. 2.166 (p. B-239)

The O&M Standards for private stormwater facilities are provided in Appendix A and are listed alphabetically by topic. Links to the O&M Standards are available in the bookmarks of the PDF version of this document.

2.6 Spill Control and Cleanup

Problem/Need

Spill prevention and response on the property.

Spill cleanup for vehicles and equipment when in accidents or leaking.

Spill cleanup for dumpster, grease container, or recycling container overflows or spills.

Triggers include routine maintenance, citizen concerns/requests, physical inspection, observed field conditions.

Relevant Activities

Done by:

- Property Owner Maintenance Staff

Ancillary work by:

- Property Management Company
- Contractor

Overlaps with:

- Animal and Solid Waste Management
- General Property Maintenance and Good Housekeeping

Frequency

Routine:

- Spill cleanup
- Emergency access
- In response to equipment break downs, vehicle incidents and spills

Special:

- Emergency spill response
- After special events, holidays, or large crowds
- City maintenance request
- In response to citizen complaints

Desired Result

Spills are cleaned up prior to entering the private storm system, the City's MS4, or infiltrating into groundwater.

Resources

Special Equipment:

- Street sweeper
- Vactor truck (if entered private storm system or MS4)
- Spill kits and cat litter (non-oil-based spills)
- Absorbent materials for oil-based spills
- Hand tools
- ESC BMPs (silt socks, straw wattles, etc.)
- PPE

Procedures

General steps:

- Rent special equipment as needed
- Install ESC BMPs as needed
- Traffic Control as needed
- Properly dispose of waste fluids and spill cleanup waste materials
- Remove traffic control devices and ESC BMPs, as applicable

Pre-planning activities include:

- Scheduling
- Develop and maintain a Spill Response Plan (SRP)
- Safety data sheet (SDS) for hazardous materials or dangerous waste stored at site
- Staff, equipment, and parts availability
- Weather forecast

Record-keeping and Documentation

Record-keeping for maintenance at private stormwater facilities should include the details provided under Section 2.1 *Access and Inspection* of this SMP. Records and documentation are required to be submitted to the City, which maintains inspection records for all Private Stormwater Facility Inspections and tracks deficiencies and maintenance progress.

Additional record-keeping and documentation is required for spills, including calling the City's pollution hotline number at 253-770-3336, notifying the Washington State Department of Ecology at 360-407-6300. For larger spills or spills directly to natural waters, notify the Coast Guard at 1-800-424-8802.

BMPs and Maintenance Standards

Reference BMPs to use for Spill Control and Cleanup are listed below (see Table 2 for links to BMPs in Appendix B).

Ecology SWMMWW

- Materials on Hand, II-3.2, C150
- Material Delivery, Storage, and Containment, II-3.2, C153
- Inlet Protection, II-3.3, C220
- Wattles, II-3.3, C235
- Spill Prevention and Cleanup, IV-1, S455
- Spills of Oil and Hazardous Substances, IV-6, S426
- Formation of a Pollution Prevention Team, IV-1, S453
- Preventive Maintenance / Good Housekeeping, IV-1, S454
- Employee Training, IV-1, S456
- Parking and Storage of Vehicles and Equipment, IV-3, S421
- Storage of Dry Pesticides and Fertilizer, IV-4, S444
- Storage of Liquid, Food Waste, or Dangerous Waste Containers, IV-5, S427
- Storage of Liquids in Permanent Aboveground Tanks, IV-5, S428
- Storage or Transfer (Outside) of Solid Raw Materials, Byproducts, or Finished Products, IV-5, S429
- Fueling At Dedicated Stations, IV-6, S409
- Loading and Unloading Areas for Liquid or Solid Material, IV-6, S412
- Mobile Fueling of Vehicles and Heavy Equipment, IV-6, S419

King County Pollution Prevention Manual

- Storage of Liquid Materials in Portable Containers, 3.0, A-3
- Storage of Contaminated Soils, 3.0, A-6
- Cleaning or Washing of Tools and Equipment, 3.0, A-11
- Cleaning and Washing of Food Service Areas, 3.0, A-12
- Chemical Application, 3.0, A-25
- Swimming Pool and Spa Cleaning and Maintenance, 3.0, A-33
- Potable Water Line Flushing, Water Tank Maintenance and Hydrant Testing, 3.0, A-42

The O&M Standards for private stormwater facilities are provided in Appendix A and are listed alphabetically by topic. Links to the O&M Standards are available in the bookmarks of the PDF version of this document.

2.7 Snow and Ice Control

Problem/Need

Removal and control of snow and ice from private properties.

Triggers include weather, observed field conditions, and citizen concerns/requests.

Relevant Activities

Done by:

- Property Owner Maintenance Staff

Ancillary work by:

- Property Management Company
- Contractor

Overlaps with:

- Access and Inspection
- Spill Control and Cleanup
- General Property Maintenance and Good Housekeeping

Frequency

Routine:

- In anticipation of, during, and following snow and freezing weather events
- Emergency access

Special:

- City maintenance request
- In response to citizen complaints

Desired Result

Safe roads, parking lots, and sidewalk conditions for the public and City staff during periods of snow and freezing wet weather.

Resources

Special Equipment:

- Truck with plow mounted
- Gator with blade
- Excavator
- Bobcat
- Dump truck
- Snowplow
- V-box plow
- De-icer tank/sprayer
- De-icer brine maker
- Hand tools
- PPE

Procedures

General steps:

- Route planning
- Rent needed equipment
- Snow removal
- Cleanup and street sweeping

Pre-planning activities include:

- Pre-planned and documented de-icer and plow routes
- Mapping and knowledge of permeable pavement and porous sidewalk locations. Permeable pavement and porous sidewalks should use limited amounts of de-icer and sand to prevent clogging and groundwater contamination.
- Weather forecast
- Scheduling
- Staff, equipment, and parts availability

Record-keeping and Documentation

Record-keeping for maintenance at private stormwater facilities should include the details provided under Section 2.1 *Access and Inspection* of this SMP. Records and documentation are required to be submitted to the City, which maintains inspection records for all Private Stormwater Facility Inspections and tracks deficiencies and maintenance progress.

In addition, special record-keeping is required for de-icing activities to record how much and what type of deicing salt and sand are used.

BMPs and Maintenance Standards

Reference BMPs to use for Snow and Ice Control are listed below (see Table 2 for links to BMPs in Appendix B).

Ecology SWMMWW

- Material Delivery, Storage, and Containment, II-3.2, C153
- Storage of Liquid, Food Waste, or Dangerous Waste Containers, IV-5, S427
- Storage of Liquids in Permanent Aboveground Tanks, IV-5, S428
- Storage or Transfer (Outside) of Solid Raw Materials, Byproducts, or Finished Products, IV-5, S429
- Loading and Unloading Areas for Liquid or Solid Material, IV-6, S412
- Spills of Oil and Hazardous Substances, IV-6, S426

King County Pollution Prevention Manual

- Outdoor Storage of Liquid Materials in Stationary Tanks, 3.0, A-2
- Storage of Liquid Materials in Portable Containers, 3.0, A-3
- Cleaning or Washing of Tools and Equipment, 3.0, A-11
- Parking Lots, Driveways and Outside Storage Areas, 3.0, A-31
- Sidewalk Maintenance, 3.0, A-32

The O&M Standards for private stormwater facilities are provided in Appendix A and are listed alphabetically by topic. Links to the O&M Standards are available in the bookmarks of the PDF version of this document.

2.8 Sediment and Erosion Control, Dewatering, and Flood Control

Problem/Need

Routine maintenance for flood control structures, including berms, dikes, and emergency overflows and erodible banks, slopes, and stockpiles on private property. Scouring repairs from high flows.

Removal of eroded soil from floods and earth works projects.

Lowering of a high-water table for safe and efficient construction activities.

Triggers include routine maintenance, citizen concerns/requests, physical inspections, weather, flooding, and observed field conditions.

Relevant Activities

Done by:

- Property Owner Maintenance Staff
- Contractor

Ancillary work by:

- Property Management Company
- Professional Landscaper

Overlaps with:

- Access and Inspection
- Cleaning, Maintenance, and Repair of Aboveground BMPs
- Cleaning, Maintenance, and Repair of Underground BMPs
- Vegetation Maintenance and Chemical Applications
- Animal and Solid Waste Management
- General Property Maintenance and Good Housekeeping

Frequency

Routine:

- Routine inspections
- Preventative maintenance
- Emergency access

ASPECT CONSULTING

Special:

- After large storm events
- City maintenance request
- Onsite construction and maintenance projects
- In response to citizen complaints

Desired Result

Prevent flooding and erosion at construction and industrial sites.

Maintain the structural integrity of flood control structures.

Limit the exposure of erodible soil. Stabilize or cover stockpiles where necessary to prevent erosion.

Removal of dewatering water in vaults, tanks, trenches, and other structures.

Resources

Special Equipment:

- Plastic sheeting to cover stockpiles
- Sandbags
- Filter fabric for catch basins
- Silt fencing
- Pumps and hoses
- Hand tools
- ESC BMPs
- PPE

Procedures

General steps:

- Rent special equipment as needed
- Install soil stabilization and other ESC BMPs
- Dewatering excavated areas
- Properly dispose of debris and vegetation
- Sweeping
- Clean work area and remove traffic control devices and ESC BMPs, as applicable

Pre-planning activities:

- Scheduling
- Staff, equipment, and parts availability
- Establish access

- Weather forecast
- Required Environmental permits (in-stream work only)
- For construction projects, refer to site-specific SWPPP and erosion control plan
- For Industrial Properties, refer to Individual Stormwater General Permit (ISGP)

Record-keeping and Documentation

Record-keeping for maintenance at private stormwater facilities should include the details provided under Section 2.1 *Access and Inspection* of this SMP. Records and documentation are required to be submitted to the City, which maintains inspection records for all Private Stormwater Facility Inspections and tracks deficiencies and maintenance progress.

In addition, record-keeping for erosion and sediment control (ESC) activities should follow the requirements of the site Stormwater Pollution Prevention Plan (SWPPP) or the construction erosion control plan.

BMPs and Maintenance Standards

Reference BMPs to use for Sediment and Erosion Control, Dewatering, and Flood Control are listed below (see Table 2 for links to BMPs in Appendix B).

Ecology SWMMWW

- Stabilized Construction Entrance, II-3.2, C105
- Nets and Blankets, II-3.2, C122
- Plastic Covering, II-3.2, C123
- Mulching, II-3.2, C121
- Certified Erosion and Sediment Control Lead, II-3.2, C160
- Scheduling, II-3.2, C162
- Riprap Channel Lining, II-3.3, C202
- Outlet protection, II-3.3, C209
- Inlet protection, II-3.3, C220
- Silt Fence, II-3.3, C233
- Straw Wattles, II-3.3, C235
- Maintenance of Roadside Ditches, IV-3, S416
- Dust Control at Disturbed Land Areas and Unpaved Roadways and Parking Lots, IV-4, S407
- Soil Erosion and Sediment Control at Industrial Sites, IV-4, S425
- Irrigation, IV-4, S450
- Pools, Spas, Hot Tubs, and Fountains, IV-7, S433

King County Pollution Prevention Manual

- Washing of Buildings, Rooftops, and Other Large Surfaces, 3.0, A-15
- Clearing and Grading for Small Construction Projects, 3.0, A-27

ASPECT CONSULTING

- Swimming Pool and Spa Cleaning and Maintenance, 3.0, A-33
- Potable Water Line Flushing, Water Tank Maintenance and Hydrant Testing, 3.0, A-42

Regional Road Maintenance Guidelines ESA Manual

- Dewatering, no. 2.50 (p. B-231)
- Dust Control, no. 2.61 (p. B-233)
- Hand Seeding, no. 2.75 (p. B-235)
- Hydroseeding, no. 2.77 (p. B-237)

The O&M Standards for private stormwater facilities are provided in Appendix A and are listed alphabetically by topic. Links to the O&M Standards are available in the bookmarks of the PDF version of this document.

2.9 Asphalt and Concrete Pavement Repair, Resurfacing, and Cleaning

Problem/Need

Repair of roadways, sidewalks, parking lots, and other paved areas on private property.

Striping or restriping on private roadways and parking lots.

Cleaning roadways, sidewalks, parking lots and concrete pads.

Sweeping of debris and grindings during road or parking lot repair and resurfacing.

Repair and resurfacing of private roadways, public parking lots, and other paved areas, including:

- Patching, grinding, chip sealing, crack sealing, and asphalt overlay
- Sidewalk repair and replacement
- Curb and gutter repair and replacement
- Sawcutting and grinding

Triggers include routine maintenance, citizen concerns/requests, observed field conditions, emergency repairs/ response, and clogged permeable pavements.

Relevant Activities

Done by:

- Property Owner Maintenance Staff
- Contractor

Overlaps with:

- Access and Inspection
- Cleaning, Maintenance, and Repair of Aboveground BMPs
- Cleaning, Maintenance, and Repair of Underground BMPs
- Animal and Solid Waste Management
- Spill Control and Cleanup
- Snow and Ice Control
- Sediment and Erosion Control, Dewatering, and Flood Control

Frequency

Routine:

- Yearly scheduled maintenance
- In response to vehicle incidents or spills

Special:

- Emergency repairs/ response (e.g., road and shoulder damage, water main breaks)
- In response to citizen concerns/requests.
- After storm events where permeable pavements have poor infiltration rates or standing water.

Desired Result

Maintain pavement and striping within parking lots and other paved areas, as needed.

Keep private streets and parking lots clear of accumulated sediments, debris, trash, and yard waste that could impact water quality and enter the private stormwater system or MS4.

Maintain acceptable infiltration rates for permeable pavements and porous sidewalks.

Unobstructed road surface to allow safe vehicle travel at designated speed limits.

Extend the lifecycle of private roadways and parking lots.

Maintain a smooth and comfortable ride quality.

Resources

Special Equipment:

- Asphalt roller/compactor
- Asphalt/concrete saw cutter
- Backhoe
- Belt loader
- Bobcat
- Bobcat with water sprayer (dust control)
- Dump truck
- Emulsion sprayer/tank
- ESC BMPs (silt socks, straw waddles, etc.)
- Excavator
- Generators
- Grader
- Grinder vacuum
- Hand tools
- Jack hammer
- Layton box paver
- LeeBoy emulsion sprayer/tank
- Paint sprayer machine
- Paver
- Plate compactor
- Pressure washers

- Propane torches
- Service truck
- Sidewalk grinder
- Street sweeper
- Regenerative air street sweeper
- Thermo machine
- Vactor truck

Special Procedures and Notes

General steps:

- Work and route planning
- Rent special equipment as needed
- Traffic Control as needed
- Install ESC BMPs as needed
- Road repair and preparation
- Place surfacing and compact
- Sweep paved areas as scheduled
- Sweeper waste disposed at an approved facility
- Waste asphalt grindings hauled to a recycling facility
- Apply sprayed paint and thermoplastic striping
- Properly treat, recycle, and/or dispose of leftover paint and thermoplastic material
- Properly dispose of waste fluids
- Clean work area and remove traffic control devices and ESC BMPs, as applicable

Pre-planning activities include:

- Weather forecast
- Scheduling
- Pre-planned and scheduled sweeper routes
- Staff, equipment, and parts availability
- Check if permit is needed, (i.e., TCP)
- Coordination with City on when maintenance activities are scheduled

Record-keeping and Documentation

Record-keeping for maintenance at private stormwater facilities should include the details provided under Section 2.1 *Access and Inspection* of this SMP. Records and documentation are required to be submitted to the City, which maintains inspection records for all Private Stormwater Facility Inspections and tracks deficiencies and maintenance progress.

BMPs and Maintenance Standards

Reference BMPs to use for Asphalt and Concrete Pavement Repair, Resurfacing and Cleaning are listed below (see Table 2 for links to BMPs in Appendix B).

Ecology SWMMWW

- Materials on Hand, II-3.2, C150
- Concrete Handling, II-3.2, C151
- Sawcutting and Surfacing Pollution Prevention, II-3.2, C152
- Material Delivery, Storage and Containment, II-3.2, C153
- Concrete Washout Area, II-3.2, C154
- Treating and Disposing of High pH Water, II-3.3, C252
- Spill Prevention and Cleanup, IV-1, S455
- Streets and Highways, IV-3, S406
- Parking and Storage of Vehicles and Equipment, IV-3, S421
- Urban Streets, IV-3, S430
- Dust Control at Disturbed Land Areas and Unpaved Roadways and Parking Lots, IV-4, S407
- Storage of Liquid, Food Waste, or Dangerous Waste Containers, IV-5, S427
- Loading and Unloading Areas for Liquid or Solid Material, IV-6, S412
- Mobile Fueling of Vehicles and Heavy Equipment, IV-6, S419
- Spills of Oil and Hazardous Substances, IV-6, S426
- Maintenance and Repair of Vehicles and Equipment, IV-7, S414

King County Pollution Prevention Manual

- Outdoor Storage of Liquid Materials in Stationary Tanks, 3.0, A-2
- Storage of Liquid Materials in Portable Containers, 3.0, A-3
- Storage of Contaminated Soils, 3.0, A-6
- Cleaning or Washing of Tools and Equipment, 3.0, A-11
- Concrete and Asphalt Production and Recycling, 3.0, A-19
- Concrete and Asphalt Application, 3.0, A-20
- Clearing and Grading for Small Construction Projects, 3.0, A-27
- Parking Lots, Driveways and Outside Storage Areas, 3.0, A-31
- Sidewalk Maintenance, 3.0, A-32
- Dust Control for Commercial Applications, 3.0, A-44

Regional Road Maintenance Guidelines ESA Manual

- Dust Control, no. 2.61 (p. B-233)

The O&M Standards for private stormwater facilities are provided in Appendix A and are listed alphabetically by topic. Links to the O&M Standards are available in the bookmarks of the PDF version of this document.

2.10 General Property Maintenance and Good Housekeeping

Problem/Need

General property maintenance, including cleaning, sweeping, washing, and cleanup.

Training for City staff and establishing pollution prevention teams.

Prevent contamination of stormwater and surface waters during exterior cleaning; installation and repairs of fencing, gates, bollards, and other access repairs; and other general maintenance activities at private property buildings.

Triggers include routine maintenance, citizen concerns/requests, physical inspection, observed field conditions, and weather.

Relevant Activities

Done by:

- Property Owner Maintenance Staff

Ancillary work by:

- Property Management Company
- Professional Landscaper
- Contractor

Overlaps with:

- Access and Inspection
- Cleaning, Maintenance, and Repair of Aboveground BMPs
- Cleaning, Maintenance, and Repair of Underground BMPs
- Vegetation Maintenance and Chemical Applications
- Animal and Solid Waste Management
- Spill Control and Cleanup
- Snow and Ice Control
- Sediment and Erosion Control, Dewatering, and Flood Control

Frequency

Routine:

- Routine inspections
- Preventative maintenance
- Emergency repairs/response
- Emergency access

Special:

- City maintenance request
- In response to citizen complaints

Desired Result

Maintained property appearance and access for vehicles and people.

Employees are trained, pollution prevention plans are in place, and records are maintained for all stormwater-related activities.

Keep paved areas clear of accumulated sediments, debris, trash, and yard waste that could impact water quality and enter the MS4.

Cleaned and maintained building exterior surface and grounds.

Resources

Special Equipment:

- Service truck
- Pressure washers
- Street sweeper
- Line trimmers
- Mowers
- Chain saw
- Pole saw
- Hedge trimmers
- Backpack blower
- Handheld blower
- Generators
- Pressure washers
- Hand tools
- Spill kit
- ESC BMPs (silt socks, straw wattles, etc.)
- Confined space entry equipment as needed
- PPE

Procedures

General steps:

- Work and route planning
- Rent special equipment as needed
- Traffic Control as needed
- Install ESC BMPs as needed
- Pressure wash building exterior

- Properly dispose of waste fluids
- Clean work area and remove traffic control devices and ESC BMPs, as applicable

Pre-planning activities include:

- Weather forecast
- Scheduling
- Staff, equipment, and parts availability
- Pre-planned and scheduled sweeping and striping
- Check if permit is needed, (i.e., TCP)
- Coordination with City on when maintenance activities are scheduled

Record-keeping and Documentation

Record-keeping for maintenance at private stormwater facilities should include the details provided under Section 2.1 *Access and Inspection* of this SMP. Records and documentation are required to be submitted to the City, which maintains inspection records for all Private Stormwater Facility Inspections and tracks deficiencies and maintenance progress.

BMPs and Maintenance Standards

Reference BMPs to use for General Property Maintenance and Good Housekeeping are listed below (see Table 2 for links to BMPs in Appendix B).

Ecology SWMMWW

- Material Delivery, Storage, and Containment, II-3.2, C153
- Correcting Illicit Connections to Storm Drains, IV-1, S410
- Formation of a Pollution Prevention Team, IV-1, S453
- Preventive Maintenance / Good Housekeeping, IV-1, S454
- Spill Prevention and Cleanup, IV-1, S455
- Employee Training, IV-1, S456
- Inspections, IV-1, S457
- Record Keeping, IV-1, S458
- Washing and Steam Cleaning Vehicles/Equipment/Building Structures, IV-2, S431
- Maintenance of Public and Private Utility Corridors and Facilities, IV-3, S415
- Maintenance of Roadside Ditches, IV-3, S416
- Parking and Storage of Vehicles and Equipment, IV-3, S421
- Landscaping and Lawn/Vegetation Management, IV-4, S411
- Storage of Dry Pesticides and Fertilizer, IV-4, S444
- Storage of Liquid, Food Waste, or Dangerous Waste Containers, IV-5, S427
- Storage of Liquids in Permanent Aboveground Tanks, IV-5, S428
- Storage or Transfer (Outside) of Solid Raw Materials, Byproducts, or Finished Products, IV-5, S429

ASPECT CONSULTING

- Loading and Unloading Areas for Liquid or Solid Material, IV-6, S412
- Spills of Oil and Hazardous Substances, IV-6, S426
- Maintenance and Repair of Vehicles and Equipment, IV-7, S414
- Painting/Finishing/Coating of Vehicles/Boats/Buildings/Equipment, IV-7, S420
- Roof/Building Drains at Manufacturing and Commercial Buildings, IV-7, S424
- Pet Waste, IV-7, S440
- Labeling Storm Drain Inlets on Your Property, IV-7, S442
- Building, Repair, Remodeling, Painting, and Construction, IV-7, S451
- Goose Waste, IV-7, S452

King County Pollution Prevention Manual

- Outdoor Storage of Liquid Materials in Stationary Tanks, 3.0, A-2
- Storage of Liquid Materials in Portable Containers, 3.0, A-3
- Storage of Contaminated Soils, 3.0, A-6
- Cleaning or Washing of Tools and Equipment, 3.0, A-11
- Interior Washing Operations, 3.0, A-14
- Washing of Buildings, Rooftops, and Other Large Surfaces, 3.0, A-15
- Building Repair, Remodeling, and Construction, 3.0, A-29
- Parking Lots, Driveways and Outside Storage Areas, 3.0, A-31
- Sidewalk Maintenance, 3.0, A-32
- Animal Waste, 3.0, A-34
- Nurseries and Greenhouses, 3.0, A-49

The O&M Standards for private stormwater facilities are provided in Appendix A and are listed alphabetically by topic. Links to the O&M Standards are available in the bookmarks of the PDF version of this document.

BIOPOD™ SYSTEM

with StormMix™ Media

Inspection & Maintenance Guide

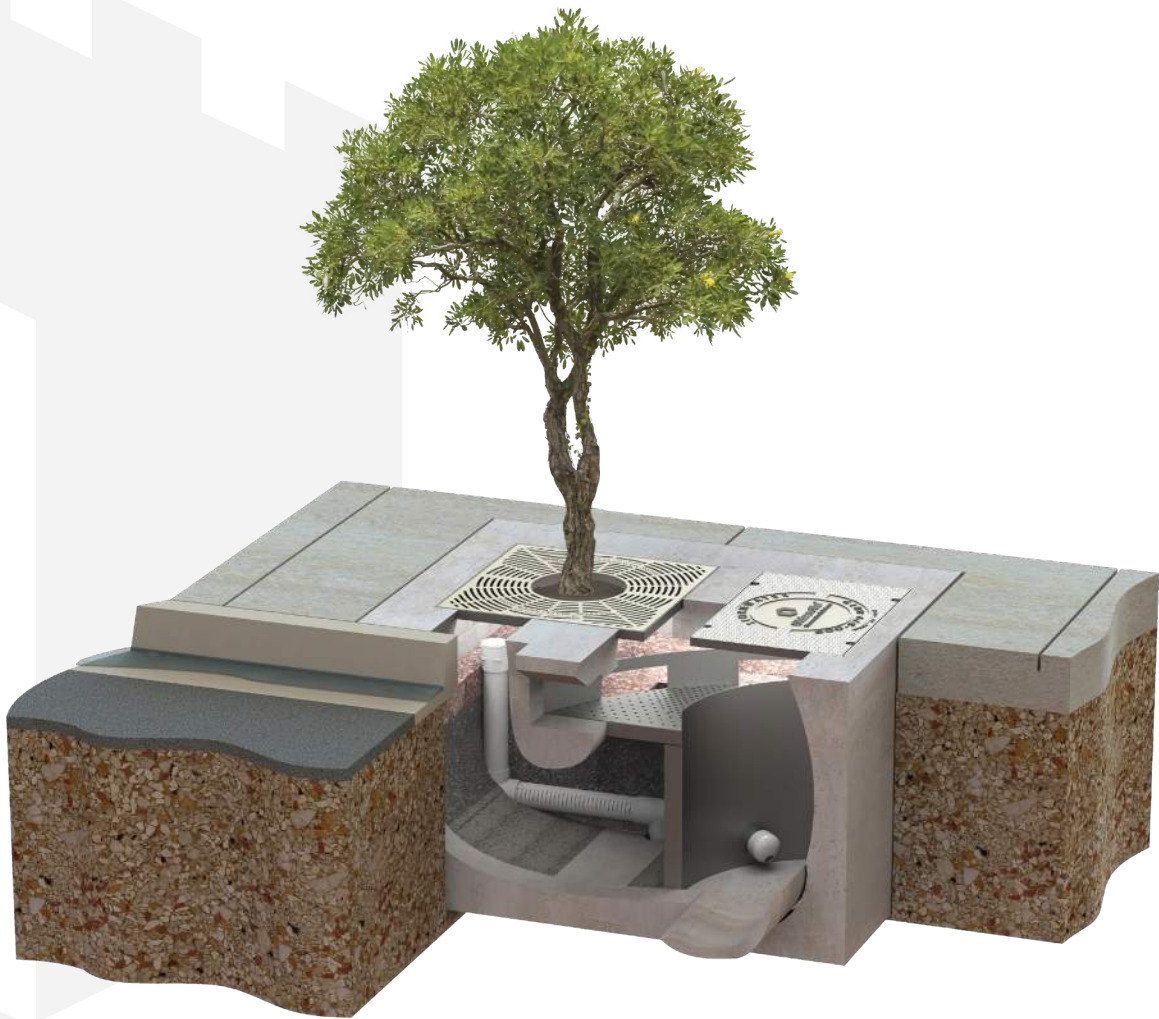

BIOPOD™ BIOFILTER WITH STORMMIX™ BIOFILTRATION MEDIA

DESCRIPTION

The BioPod™ Biofilter System (BioPod) is a storm water biofiltration treatment system used to remove pollutants from storm water runoff. Impervious surfaces and other urban and suburban landscapes generate a variety of contaminants that can enter storm water and pollute downstream receiving waters unless treatment is provided. The BioPod system uses proprietary StormMix™ biofiltration media to capture and retain pollutants including total suspended solids (TSS), metals, nutrients, gross solids, trash and debris as well as petroleum hydrocarbons.

FUNCTION

The BioPod system uses engineered, high-flow rate filter media to remove storm water pollutants, allowing for a smaller footprint than conventional bioretention systems. Contained within a compact precast concrete vault, the BioPod system consists of a biofiltration chamber and an optional integrated high-flow bypass. The biofiltration chamber is filled with horizontal layers of aggregate, biofiltration media and mulch. Storm water passes vertically down through the mulch and biofiltration media for treatment. The mulch provides pretreatment by retaining most of the solids or sediment. The biofiltration media provides further treatment by retaining finer sediment and dissolved pollutants. The aggregate allows the media bed to drain evenly for discharge through an underdrain pipe or by infiltration.

INSPECTION & MAINTENANCE OVERVIEW

State and local regulations require all storm water management systems to be inspected on a regular basis and maintained as necessary to ensure performance and protect downstream receiving waters. Without maintenance, excessive pollutant buildup can limit system performance by reducing the operating capacity of the system and increasing the potential for scouring of pollutants during periods of high flow.

Some configurations of the BioPod may require periodic irrigation to establish and maintain vegetation. Vegetation will typically become established about two years after planting. Irrigation requirements are ultimately dependent on climate, rainfall and the type of vegetation selected.

INSPECTION & MAINTENANCE FREQUENCY

Periodic inspection is essential for consistent system performance and is easily completed. Inspection is typically conducted a minimum of twice per year, but since pollutant transport and deposition varies from site to site, a site-specific maintenance frequency should be established during the first two or three years of operation.



INSPECTION EQUIPMENT

The following equipment is helpful when conducting BioPod inspections:

- | Recording device (pen and paper form, voice recorder, iPad, etc.)
- | Suitable clothing (appropriate footwear, gloves, hardhat, safety glasses, etc.)
- | PPE as required for entry
- | Traffic control equipment (cones, barricades, signage, flagging, etc.)
- | Manhole hook or pry bar
- | Flashlight
- | Tape measure
- | Socket

INSPECTION PROCEDURES

BioPod inspections are visual and are conducted without entering the unit. To complete an inspection, safety measures including traffic control should be deployed before the access covers or tree grates are removed. Once the covers have been removed, the following items should be checked and recorded (see form provided on page 6) to determine whether maintenance is required:

- | If the BioPod unit is equipped with an internal bypass, inspect the inlet rack (or inlet chamber on underground units) and outlet chamber and note whether there are any broken or missing parts. In the unlikely event that internal parts are broken or missing, contact Oldcastle Storm water at (800) 579-8819 to determine appropriate corrective action.
- | Note whether the curb inlet, inlet pipe, or inlet rack is blocked or obstructed.
- | If the unit is equipped with an internal bypass, observe, quantify and record the accumulation of trash and debris in the inlet rack or inlet chamber. The significance of accumulated trash and debris is a matter of judgment. Often, much of the trash and debris may be removed manually at the time of inspection if a separate maintenance visit is not yet warranted.
- | If it has not rained within the past 24 hours, note whether standing water is observed in the biofiltration chamber.
- | Finally, observe, quantify and record presence of invasive vegetation and the amount of trash and debris and sediment load in the biofiltration chamber. Erosion of the mulch and biofiltration media bed should also be recorded. Often, much of the invasive vegetation and trash and debris may be removed manually at the time of inspection if a separate maintenance visit is not yet warranted. Sediment load may be rated light, medium or heavy depending on the conditions. Loading characteristics may be determined as follows:
 - **Light sediment load** – sediment is difficult to distinguish among the mulch fibers at the top of the mulch layer; the mulch appears almost new.
 - **Medium sediment load** – sediment accumulation is apparent and may be concentrated in some areas; probing the mulch layer reveals lighter sediment loads under the top 1" of mulch.
 - **Heavy sediment load** – sediment is readily apparent across the entire top of the mulch layer; individual mulch fibers are difficult to distinguish; probing the mulch layer reveals heavy sediment load under the top 1" of mulch.

MAINTENANCE INDICATORS

Maintenance should be scheduled if any of the following conditions are identified during inspection:

- | The concrete structure is damaged or the tree grate or access cover is damaged or missing
- | The inlet obstructed
- | Standing water is observed in the biofiltration chamber more than 24 hours after a rainfall event (use discretion if the BioPod is located downstream of a storage system that attenuates flow)
- | Trash and debris in the inlet rack cannot be easily removed at the time of inspection
- | Trash and debris, invasive vegetation or sediment load in the biofiltration chamber is heavy or excessive erosion has occurred

MAINTENANCE EQUIPMENT

The following equipment is helpful when conducting BioPod maintenance:

- | Suitable clothing (appropriate footwear, gloves, hardhat, safety glasses, etc.)
- | PPE as required for entry
- | Traffic control equipment (cones, barricades, signage, flagging, etc.)
- | Manhole hook or pry bar
- | Flashlight
- | Tape measure
- | Rake, hoe, shovel and broom
- | Bucket
- | Pruners
- | Vacuum truck (optional)
- | Socket

MAINTENANCE PROCEDURES

Maintenance should be conducted during dry weather when no flows are entering the system. In most cases, maintenance may be conducted without entering. Entry may be required to maintain BioPod Underground units, depending on system depth. Once safety measures such as traffic control are deployed, the access covers may be removed and the following activities may be conducted to complete maintenance:

- | Remove all trash and debris from the curb inlet and inlet rack manually or by using a vacuum truck as required.
- | Remove all trash and debris and invasive vegetation from the biofiltration chamber manually or by using a vacuum truck as required.
- | If the sediment load is medium or light but erosion of the biofiltration media bed is evident, redistribute the mulch with a rake or replace missing mulch as appropriate. If erosion persists, rocks may be placed in the eroded area to help dissipate energy and prevent recurring erosion.
- | If the sediment load is heavy, remove the mulch layer using a hoe, rake, shovel and bucket, or by using a vacuum truck as required. If the sediment load is particularly heavy, inspect the surface of the biofiltration media once the mulch has been removed. If the media appears clogged with sediment, remove and replace one or two inches of biofiltration media prior to replacing the mulch* layer.
- | Prune vegetation as appropriate and replace damaged or dead plants as required.
- | Replace the tree grate and/or access covers and sweep the area around the BioPod to leave the site clean.
- | All material removed from the BioPod during maintenance must be disposed of in accordance with local environmental regulations. In most cases, the material may be handled in the same manner as disposal of material removed from sumped catch basins or manholes.



* Natural, shredded hardwood mulch should be used in the BioPod. Timely replacement of the mulch layer according to the maintenance indicators described above should protect the biofiltration media below the mulch layer from clogging due to sediment accumulation. However, whenever the mulch is replaced, the BioPod should be visited 24 hours after the next major storm event to ensure that there is no standing water in the biofiltration chamber. Standing water indicates that the biofiltration media below the mulch layer is clogged and must be replaced. Please contact Oldcastle Infrastructure at (800) 579-8819 to purchase the proprietary StormMix™ biofiltration media.



BIOPOD TREE



BIOPOD SURFACE



BIOPOD PLANTER



BIOPOD UNDERGROUND

BIPOD INSPECTION & MAINTENANCE LOG

BioPod Model _____ Inspection Date _____

Location _____

Condition of Internal Components

NOTES:

GOOD **DAMAGED** **MISSING**

Curb Inlet or Inlet Rack Blocked

NOTES:

YES **NO**

Standing Water in Biofiltration Chamber

NOTES:

YES **NO**

Trash and Debris in Inlet Rack

NOTES:

YES **NO**

Trash and Debris in Biofiltration Chamber

NOTES:

YES **NO**

Invasive Vegetation in Biofiltration Chamber

NOTES:

YES **NO**

Sediment in Biofiltration Chamber

NOTES:

LIGHT **MEDIUM** **HEAVY**

Erosion in Biofiltration Chamber

NOTES:

YES **NO**

Maintenance Requirements

YES - Schedule Maintenance **NO - Schedule Re-Inspection**



Oldcastle Infrastructure[™]
A CRH COMPANY

Appendix D

Drainage Calculations

- D-1.....Water Quality WWHM Report
- D-2.....Biopod Department of Ecology Design Sheet and Calculations
- D-3.....Conveyance Calculations and Analysis

WWHM2012 PROJECT REPORT

Include all outputs from WWHM modeling in this section. See pre-application notes. RE: Snips on page 177/318 and other missing output information. [STORM REPORT, Page 151/318]

the report has been updated to include missing data

General Model Information

Project Name: 20240222 Updated Prelim
Site Name: CFPD
Site Address: 322 VALLEY AVE NW
City: PUYALLUP
Report Date: 2/26/2024
Gage: 38 IN CENTRAL
Data Start: 10/01/1901
Data End: 09/30/2059
Timestep: 15 Minute
Precip Scale: 1.000
Version Date: 2021/08/18
Version: 4.2.18

POC Thresholds

Low Flow Threshold for POC1:	50 Percent of the 2 Year
High Flow Threshold for POC1:	50 Year

Landuse Basin Data
Predeveloped Land Use

Mitigated Land Use

Post-Developed Site

Bypass:	No
GroundWater:	No
Pervious Land Use	acre
C, Lawn, Flat	0.83
Pervious Total	0.83
Impervious Land Use	acre
ROOF TOPS FLAT	1.45
SIDEWALKS FLAT	0.15
PARKING FLAT	1.78
Impervious Total	3.38
Basin Total	4.21

Element Flows To:		
Surface	Interflow	Groundwater

Routing Elements
Predeveloped Routing

Mitigated Routing

Analysis Results

POC 1

POC #1 was not reported because POC must exist in both scenarios and both scenarios must have been run.

POC 2

POC #2 was not reported because POC must exist in both scenarios and both scenarios must have been run.

Model Default Modifications

Total of 0 changes have been made.

PERLND Changes

No PERLND changes have been made.

IMPLND Changes

No IMPLND changes have been made.

Appendix
Predeveloped Schematic



Mitigated Schematic



Post-Develop
Site
4.21ac

Predeveloped UCI File

Mitigated UCI File

RUN

GLOBAL

```
WVHM4 model simulation
START      1901 10 01      END      2059 09 30
RUN INTERP OUTPUT LEVEL   3      0
RESUME     0 RUN         1
UNIT SYSTEM 1
```

END GLOBAL

FILES

```
<File> <Un#> <-----File Name----->***
<-ID->                                     ***
WDM      26      20240222 Updated Prelim.wdm
MESSU    25      Mit20240222 Updated Prelim.MES
          27      Mit20240222 Updated Prelim.L61
          28      Mit20240222 Updated Prelim.L62
          30      POC20240222 Updated Prelim1.dat
```

END FILES

OPN SEQUENCE

```
INGRP          INDELT 00:15
  PERLND        16
  IMPLND         4
  IMPLND         8
  IMPLND        11
  COPY          501
  DISPLY         1
```

END INGRP

END OPN SEQUENCE

DISPLY

DISPLY-INF01

```
# - #<-----Title----->***TRAN PIVL DIG1 FIL1  PYR DIG2 FIL2 YRND
1      Post-Developed Site          MAX          1      2      30      9
```

END DISPLY-INF01

END DISPLY

COPY

TIMESERIES

```
# - # NPT NMN ***
1      1      1
501    1      1
```

END TIMESERIES

END COPY

GENER

OPCODE

```
#      # OPCODE ***
```

END OPCODE

PARAM

```
#      #          K ***
```

END PARAM

END GENER

PERLND

GEN-INFO

```
<PLS ><-----Name----->NBLKS  Unit-systems  Printer ***
# - #          User  t-series  Engl Metr ***
          in  out          ***
16      C, Lawn, Flat          1      1      1      1      27      0
```

END GEN-INFO

*** Section PWATER***

ACTIVITY

```
<PLS > ***** Active Sections *****
# - # ATMP SNOW PWAT  SED  PST  PWG  PQAL MSTL  PEST  NITR  PHOS  TRAC ***
16      0      0      1      0      0      0      0      0      0      0      0
```

END ACTIVITY

PRINT-INFO

```
<PLS > ***** Print-flags ***** PIVL  PYR
# - # ATMP SNOW PWAT  SED  PST  PWG  PQAL MSTL  PEST  NITR  PHOS  TRAC  *****
```

16 0 0 4 0 0 0 0 0 0 0 0 0 0 1 9
END PRINT-INFO

PWAT-PARM1
<PLS > PWATER variable monthly parameter value flags ***
- # CSNO RTOP UZFG VCS VUZ VNN VIFW VIRC VLE INFC HWT ***
16 0 0 0 0 0 0 0 0 0 0 0
END PWAT-PARM1

PWAT-PARM2
<PLS > PWATER input info: Part 2 ***
- # ***FOREST LZSN INFILT LSUR SLSUR KVARY AGWRC
16 0 4.5 0.03 400 0.05 0.5 0.996
END PWAT-PARM2

PWAT-PARM3
<PLS > PWATER input info: Part 3 ***
- # ***PETMAX PETMIN INFEXP INFILD DEEPFR BASETP AGWETP
16 0 0 2 2 0 0 0
END PWAT-PARM3

PWAT-PARM4
<PLS > PWATER input info: Part 4 ***
- # CEPSC UZSN NSUR INTFW IRC LZETP ***
16 0.1 0.25 0.25 6 0.5 0.25
END PWAT-PARM4

PWAT-STATE1
<PLS > *** Initial conditions at start of simulation
ran from 1990 to end of 1992 (pat 1-11-95) RUN 21 ***
- # *** CEPS SURS UZS IFWS LZS AGWS GWVS
16 0 0 0 0 2.5 1 0
END PWAT-STATE1

END PERLND

IMPLND

GEN-INFO
<PLS ><-----Name-----> Unit-systems Printer ***
- # User t-series Engl Metr ***
in out ***
4 ROOF TOPS/FLAT 1 1 1 27 0
8 SIDEWALKS/FLAT 1 1 1 27 0
11 PARKING/FLAT 1 1 1 27 0
END GEN-INFO
*** Section IWATER***

ACTIVITY
<PLS > ***** Active Sections *****
- # ATMP SNOW IWAT SLD IWG IQAL ***
4 0 0 1 0 0 0
8 0 0 1 0 0 0
11 0 0 1 0 0 0
END ACTIVITY

PRINT-INFO
<ILS > ***** Print-flags ***** PIVL PYR
- # ATMP SNOW IWAT SLD IWG IQAL *****
4 0 0 4 0 0 0 1 9
8 0 0 4 0 0 0 1 9
11 0 0 4 0 0 0 1 9
END PRINT-INFO

IWAT-PARM1
<PLS > IWATER variable monthly parameter value flags ***
- # CSNO RTOP VRS VNN RTLI ***
4 0 0 0 0 0
8 0 0 0 0 0
11 0 0 0 0 0
END IWAT-PARM1

```

IWAT-PARM2
<PLS >          IWATER input info: Part 2          ***
# - # ***  LSUR      SLSUR      NSUR      RETSC
4         400      0.01      0.1      0.1
8         400      0.01      0.1      0.1
11        400      0.01      0.1      0.1
END IWAT-PARM2

```

```

IWAT-PARM3
<PLS >          IWATER input info: Part 3          ***
# - # ***PETMAX    PETMIN
4         0         0
8         0         0
11        0         0
END IWAT-PARM3

```

```

IWAT-STATE1
<PLS > *** Initial conditions at start of simulation
# - # ***  RETS      SURS
4         0         0
8         0         0
11        0         0
END IWAT-STATE1

```

END IMPLND

```

SCHEMATIC
<-Source->          <--Area-->          <-Target->  MBLK    ***
<Name> #           <-factor->          <Name> #    Tbl#    ***
Post-Developed Site***
PERLND 16          0.83          COPY    501    12
PERLND 16          0.83          COPY    501    13
IMPLND  4          1.45          COPY    501    15
IMPLND  8          0.15          COPY    501    15
IMPLND 11          1.78          COPY    501    15

```

```

*****Routing*****
END SCHEMATIC

```

```

NETWORK
<-Volume-> <-Grp> <-Member-><--Mult-->Tran <-Target vols> <-Grp> <-Member-> ***
<Name> #      <Name> # #<-factor->strg <Name> # #      <Name> # # ***
COPY    501 OUTPUT MEAN 1 1 48.4      DISPLAY 1      INPUT TIMSER 1

```

```

<-Volume-> <-Grp> <-Member-><--Mult-->Tran <-Target vols> <-Grp> <-Member-> ***
<Name> #      <Name> # #<-factor->strg <Name> # #      <Name> # # ***
END NETWORK

```

```

RCHRES
GEN-INFO
RCHRES          Name          Nexits  Unit Systems  Printer          ***
# - #<-----><----> User T-series Engl Metr LKFG          ***
                                in out
END GEN-INFO
*** Section RCHRES***

```

```

ACTIVITY
<PLS > ***** Active Sections *****
# - # HYFG ADFG CNFG HTFG SDFG GQFG OXFG NUFQ PKFG PHFG ***
END ACTIVITY

```

```

PRINT-INFO
<PLS > ***** Print-flags ***** PIVL  PYR
# - # HYDR ADCA CONS HEAT SED  GQL  OXRX NUTR PLNK PHCB PIVL  PYR *****
END PRINT-INFO

```

```

HYDR-PARM1
RCHRES  Flags for each HYDR Section          ***

```

```

# - # VC A1 A2 A3 ODFVFG for each *** ODGTFG for each FUNCT for each
      FG FG FG FG possible exit *** possible exit possible exit
      * * * * * * * * * * * * * * * * * * * * * * * * * * * * * * * * * *
END HYDR-PARM1

HYDR-PARM2
# - # FTABNO LEN DELTH STCOR KS DB50 ***
<-----><-----><-----><-----><-----><-----><-----><-----> ***
END HYDR-PARM2
HYDR-INIT
RCHRES Initial conditions for each HYDR section ***
# - # *** VOL Initial value of COLIND Initial value of OUTDGT
      *** ac-ft for each possible exit for each possible exit
<-----><-----><-----><-----><-----><-----><-----><-----><-----> ***
END HYDR-INIT
END RCHRES

SPEC-ACTIONS
END SPEC-ACTIONS
FTABLES
END FTABLES

EXT SOURCES
<-Volume-> <Member> SsysSgap<--Mult-->Tran <-Target vols> <-Grp> <-Member-> ***
<Name> # <Name> # tem strg<-factor->strg <Name> # # <Name> # # ***
WDM 2 PREC ENGL 1 PERLND 1 999 EXTNL PREC
WDM 2 PREC ENGL 1 IMPLND 1 999 EXTNL PREC
WDM 1 EVAP ENGL 1 PERLND 1 999 EXTNL PETINP
WDM 1 EVAP ENGL 1 IMPLND 1 999 EXTNL PETINP
END EXT SOURCES

EXT TARGETS
<-Volume-> <-Grp> <-Member-><--Mult-->Tran <-Volume-> <Member> Tsys Tgap Amd ***
<Name> # <Name> # #<-factor->strg <Name> # <Name> tem strg strg***
COPY 1 OUTPUT MEAN 1 1 48.4 WDM 701 FLOW ENGL REPL
COPY 501 OUTPUT MEAN 1 1 48.4 WDM 801 FLOW ENGL REPL
END EXT TARGETS

MASS-LINK
<Volume> <-Grp> <-Member-><--Mult--> <Target> <-Grp> <-Member->***
<Name> <Name> # #<-factor-> <Name> <Name> # #***
MASS-LINK 12
PERLND PWATER SURO 0.083333 COPY INPUT MEAN
END MASS-LINK 12

MASS-LINK 13
PERLND PWATER IFWO 0.083333 COPY INPUT MEAN
END MASS-LINK 13

MASS-LINK 15
IMPLND IWATER SURO 0.083333 COPY INPUT MEAN
END MASS-LINK 15

END MASS-LINK

END RUN

```

Predeveloped HSPF Message File

Mitigated HSPF Message File

Disclaimer

Legal Notice

This program and accompanying documentation are provided 'as-is' without warranty of any kind. The entire risk regarding the performance and results of this program is assumed by End User. Clear Creek Solutions Inc. and the governmental licensee or sublicensees disclaim all warranties, either expressed or implied, including but not limited to implied warranties of program and accompanying documentation. In no event shall Clear Creek Solutions Inc. be liable for any damages whatsoever (including without limitation to damages for loss of business profits, loss of business information, business interruption, and the like) arising out of the use of, or inability to use this program even if Clear Creek Solutions Inc. or their authorized representatives have been advised of the possibility of such damages. Software Copyright © by : Clear Creek Solutions, Inc. 2005-2024; All Rights Reserved.

Clear Creek Solutions, Inc.
6200 Capitol Blvd. Ste F
Olympia, WA. 98501
Toll Free 1(866)943-0304
Local (360)943-0304

www.clearcreeksolutions.com



March 2022

GENERAL USE LEVEL DESIGNATION FOR BASIC (TSS), DISSOLVED METALS (ENHANCED), AND PHOSPHORUS TREATMENT

For

**Oldcastle Infrastructure, Inc.'s
The BioPod™ Biofilter
(Formerly the TreePod Biofilter)**

Ecology's Decision

Based on Oldcastle Infrastructure, Inc. application submissions for The BioPod™ Biofilter (BioPod), Ecology hereby issues the following use level designation:

- 1) General Use Level Designation (GULD) for Basic, Enhanced, and Phosphorus Treatment:
 - Sized at a hydraulic loading rate of 1.6 gallons per minute (gpm) per square foot (sq ft) of media surface area.
 - Constructed with a minimum media thickness of 18-inches (1.5-feet)
- 2) Ecology approves the BioPod at the hydraulic loading rate listed above, to achieve the maximum water quality design flow rate. The water quality design flow rates are calculated using the following procedures:
 - Western Washington: For treatment installed upstream of detention or retention, the water quality design flow rate is the peak 15-minute flow rate as calculated using the latest version of the Western Washington Hydrology Model or other Ecology- approved continuous runoff model.
 - Eastern Washington: For treatment installed upstream of detention or retention, the water quality design flow rate is the peak 15-minute flow rate as calculated using one of the three methods described in Chapter 2.7.6 of the Stormwater Management Manual for Eastern Washington (SWMMEW) or local manual.
 - Entire State: For treatment installed downstream of detention, the water quality design flow rate is the full 2-year release rate of the detention facility.
- 3) For systems that have a drain down outlet, designers must increase the water quality design flow rate calculated in Item 2, above, to account for the water that will enter the initial bay but won't be treated by the engineered soil. Multiply the flow rate determined above by 1.05

to determine the required flowrate for the BioPod unit.

- 4) The GULD has no expiration date, but may be amended or revoked by Ecology.

Ecology's Conditions of Use

The BioPod shall comply with these conditions:

- 1) Applicants shall design, assemble, install, operate, and maintain the BioPod installations in accordance with Oldcastle Infrastructure Inc.'s applicable manuals and the Ecology Decision.
- 2) The minimum size filter surface-area for use in Washington is determined by using the design water quality flow rate (as determined in Ecology Decision, Item 3, above) and the hydraulic loading rate (as identified in Ecology Decision, Item 1, above). Calculate the required area by dividing the water quality design flow rate (cu-ft/sec) by the hydraulic loading rate (converted to ft/sec) to obtain the required surface area (sq ft) of the BioPod unit.
- 3) BioPod media shall conform to the specifications submitted to and approved by Ecology.
- 4) The applicant tested the BioPod without plants. This GULD applies to the BioPod Stormwater Treatment System whether plants are included in the final product or not.
- 5) Maintenance: The required inspection/maintenance interval for stormwater treatment devices is often dependent on the efficiency of the device and the degree of pollutant loading from a particular drainage basin. Therefore, Ecology does not endorse or recommend a "one size fits all" maintenance cycle for a particular model/size of manufactured filter treatment device.
 - The BioPod is designed for a target maintenance interval of 1 year. Maintenance includes replacing the mulch, assessing plant health, removal of trash, and raking the top few inches of engineered media.
 - The BioPod system initially tested at the Lake Union Ship Canal Test Facility in Seattle, WA required maintenance after 1.5 months, or 6.3% of a water year. Monitoring personnel observed similar maintenance issues with other systems evaluated at the Test Facility. Runoff from the Test Facility may be unusual and maintenance requirements of systems installed at the Test Facility may not be indicative of typical maintenance requirements. Because of this, the initial version of the GULD required Oldcastle to subsequently "conduct hydraulic testing to obtain information about maintenance requirements on a site with runoff that is more typical of the Pacific Northwest". Quarterly testing from a 15-month maintenance frequency assessment conducted on a BioPod system installed along a roadway in Des Moines, WA indicated the system was able to treat a full water year before requiring maintenance.
 - Test results provided to Ecology from a BioPod System evaluated in a lab following New Jersey Department of Environmental Protection Laboratory Protocol for Filtration MTDs have indicated the BioPod System is capable of longer maintenance intervals.
 - Owners/operators must inspect BioPod systems for a minimum of twelve months from the start of post-construction operation to determine site-specific inspection/maintenance schedules and requirements. Owners/operators must conduct inspections monthly during the wet season, and every other month during the dry season. (According to the SWMMWW, the wet season in western Washington is October 1 to April 30. According

to the SWMMEW, the wet season in eastern Washington is October 1 to June 30.) After the first year of operation, owners/operators must conduct inspections based on the findings during the first year of inspections.

- Conduct inspections by qualified personnel, follow manufacturer's guidelines, and use methods capable of determining either a decrease in treated effluent flow rate and/or a decrease in pollutant removal ability.
- 6) Install the BioPod in such a manner that you bypass flows exceeding the maximum operating rate and you will not resuspend captured sediment.
 - 7) Discharges from the BioPod shall not cause or contribute to water quality standard violations in receiving waters.

Approved Alternate Configurations

BioPod Internal Bypass

- 1) The BioPod Internal Bypass configuration may be combined with a Curb Inlet, Grated Inlet, and Piped-In Inlet. Water quality flows and peak flows are directed from the curb, overhead grate, or piped inlet to a contoured inlet rack. The inlet rack disperses water quality flows over the top surface of the biofiltration chamber. Excess flows are diverted over a curved bypass weir to the outlet area without passing through the treatment area. Both water quality flows and bypass flows are combined in the outlet area prior to being discharged out of the system.
- 2) To select a BioPod Internal Bypass unit, the designer must determine the size of the standard unit using the sizing guidance described above. Systems that have an internal bypass may use the off-line water quality design flow rate.
- 3) The internal bypass configuration has a maximum flow rate of 900 gallons per minute. Sites where the anticipated flow rate at the treatment device is larger than 900 gpm must use an external bypass, or size the treatment device for the on-line water quality design flow rate.

Applicant: Oldcastle Infrastructure, Inc.

Applicant's Address: 7100 Longe St, Suite 100
Stockton, CA 95206

Application Documents:

BioPod™ Stormwater Filter Maintenance Frequency Assessment, Prepared for Oldcastle Infrastructure, Inc., Prepared by Herrera Environmental Consultants, Inc. February 2022

Technical Evaluation Report TreePod™ BioFilter System Performance Certification Project, Prepared for Oldcastle, Inc., Prepared by Herrera Environmental Consultants, Inc. February 2018

Technical Memorandum: Response to Board of External Reviewers' Comments on the Technical Evaluation Report for the TreePod™ Biofilter System Performance Certification Project, Oldcastle, Inc. and Herrera Environmental Consultants, Inc., February 2018

Technical Memorandum: Response to Board of External Reviewers' Comments on the Technical Evaluation Report for the TreePod™ Biofilter System Performance Certification Project, Oldcastle, Inc. and Herrera Environmental Consultants, Inc., January 2018

Application for Pilot Use Level Designation, TreePod™ Biofilter – Stormwater Treatment System, Oldcastle Stormwater Solutions, May 2016

Emerging Stormwater Treatment Technologies Application for Certification: The TreePod™ Biofilter, Oldcastle Stormwater Solutions, April 2016

Applicant's Use Level Request:

- General Use Level Designation as a Basic, Enhanced, and Phosphorus Treatment device in accordance with Ecology's *Stormwater Management Manual for Western Washington*

Applicant's Performance Claims:

Based on results from laboratory and field-testing, the applicant claims the BioPod™ Biofilter operating at a hydraulic loading rate of 153 inches per hour is able to remove:

- 80% of Total Suspended Solids (TSS) for influent concentrations greater than 100 mg/L and achieve a 20 mg/L effluent for influent concentrations less than 100 mg/L.
- 60% dissolved zinc for influent concentrations 0.02 to 0.3 mg/L.
- 30% dissolved copper for influent concentrations 0.005 to 0.02 mg/L.
- 50% or greater total phosphorus for influent concentrations 0.1 to 0.5 mg/L.

Ecology's Recommendations:

Ecology finds that:

- Oldcastle Infrastructure, Inc. has shown Ecology, through laboratory and field testing, that the BioPod™ Biofilter is capable of attaining Ecology's Basic, Total Phosphorus, and Enhanced treatment goals.

Findings of Fact:

Field Testing

- Herrera Environmental Consultants, Inc. conducted monitoring of the BioPod™ Biofilter at the Lake Union Ship Canal Test Facility in Seattle Washington between November 2016 and April 2018. Herrera collected flow-weight composite samples during 14 separate storm events and peak flow grab samples during 3 separate storm events. The system was sized at an infiltration rate of 153 inches per hour or a hydraulic loading rate of 1.6 gpm/ft².

- The D₅₀ of the influent PSD ranged from 3 to 292 microns, with an average D₅₀ of 28 microns.
- Influent TSS concentrations ranged from 17 mg/L to 666 mg/L, with a mean concentration of 98 mg/L. For all samples (influent concentrations above and below 100 mg/L) the bootstrap estimate of the lower 95 percent confidence limit (LCL 95) of the mean TSS reduction was 84% and the bootstrap estimate of the upper 95 percent confidence limit (UCL95) of the mean TSS effluent concentration was 8.2 mg/L.
- Dissolved copper influent concentrations from the 17 events ranged from 9.0 µg/L to 21.1 µg/L. The 21.1 µg/L data point was reduced to 20.0 µg/L, the upper limit to the TAPE allowed influent concentration range, prior to calculating the pollutant removal. A bootstrap estimate of the LCL95 of the mean dissolved copper reduction was 35%.
- Dissolved zinc influent concentrations from the 17 events ranged from 26.1 µg/L to 43.3 µg/L. A bootstrap estimate of the LCL95 of the mean dissolved zinc reduction was 71%.
- Total phosphorus influent concentrations from the 17 events ranged from 0.064 mg/L to 1.56 mg/L. All influent data greater than 0.5 mg/L were reduced to 0.5 mg/L, the upper limit to the TAPE allowed influent concentration range, prior to calculating the pollutant removal. A bootstrap estimate of the LCL95 of the mean total phosphorus reduction was 64%.
- The system experienced rapid sediment loading and needed to be maintained after 1.5 months. Monitoring personnel observed similar sediment loading issues with other systems evaluated at the Test Facility. The runoff from the Test Facility may not be indicative of maintenance requirements for all sites.
- Herrera Environmental Consultants, Inc. conducted a maintenance frequency assessment of the BioPod™ installed along a roadway in Des Moines, WA between September 2020 and January 2022.
 - Herrera collected influent grab samples during 10 storm events and paired effluent samples during 5 storm events. Influent concentrations ranged from 1 mg/L to 164 mg/L, with a median concentration of 23 mg/L. Effluent concentrations ranged from 1 mg/L to 19 mg/L, with a median of 5 mg/L.
 - Herrera collected influent PSD samples during 3 storm events. The D₅₀ for the samples were 42, 1306, and 57 microns. The 1306 micron value was collected during an event with an influent TSS concentration of 1 mg/L. It is assumed this sample was atypical and that it contained a few grains of very coarse sand and almost no other particles.
 - Herrera used a water truck to conduct flow testing 7 times to assess how long the system could filter at the design flow rate without bypass. Results show the system was able to treat up to a full water year before the system needed maintenance.

Laboratory Testing

- Good Harbour Laboratories (GHL) conducted laboratory testing at their site in Mississauga, Ontario in October 2017 following the New Jersey Department of Environmental Protection Laboratory Protocol for Filtration MTDs. The testing evaluated a 4-foot by 6-foot standard biofiltration chamber and inlet contour rack with

bypass weir. The test sediment used during the testing was custom blended by GHIL using various commercially available silica sands, which had an average d_{50} of 69 μm . Based on the lab test results:

- GHIL evaluated removal efficiency over 15 events at a Maximum Treatment Flow Rate (MTFR) of 37.6 gpm, which corresponds to a MTFR to effective filtration treatment area ratio of 1.80 gpm/ft². The system, operating at 100% of the MTFR with an average influent concentration of 201.3 mg/L, had an average removal efficiency of 99 percent.
- GHIL evaluated sediment mass loading capacity over an additional 16 events using an influent SSC concentration of 400 mg/L. The first 11 runs were evaluated at 100% of the MTFR. The BioPod began to bypass, so the remaining 5 runs were evaluated at 90% of the MTFR. The total mass of the sediment captured was 245.0 lbs and the cumulative mass removal efficiency was 96.3%.
- Herrera Environmental Consultants Inc. conducted laboratory testing in September 2014 at the Seattle University Engineering Laboratory. The testing evaluated the flushing characteristics, hydraulic conductivity, and pollutant removal ability of twelve different media blends. Based on this testing, Oldcastle Infrastructure, Inc. selected one media blend, Mix 8, for inclusion in their TAPE evaluation of the BioPod™ Biofilter.
 - Herrera evaluated Mix 8 in an 8-inch diameter by 36-inch tall polyvinyl chloride (PVC) column. The column contained 18-inches of Mix 8 on top of 6-inches of pea gravel. The BioPod will normally include a 3-inch mulch layer on top of the media layer; however, this was not included in the laboratory testing.
 - Mix 8 has a hydraulic conductivity of 218 inches per hour; however, evaluation of the pollutant removal ability of the media was based on an infiltration rate of 115 inches per hour. The media was tested at 75%, 100%, and 125% of the infiltration rate. Based on the lab test results:
 - The system was evaluated using natural stormwater. The dissolved copper and dissolved zinc concentrations in the natural stormwater were lower than the TAPE influent standards; therefore, the stormwater was spiked with 66.4 mL of 100 mg/L Cu solution and 113.6 mL of 1,000 mg/L Zn solution.
 - The BioPod removed an average of 81% of TSS, with a mean influent concentration of 48.4 mg/L and a mean effluent concentration of 9.8 mg/L.
 - The BioPod removed an average of 94% of dissolved copper, with a mean influent concentration of 10.6 $\mu\text{g/L}$ and a mean effluent concentration of 0.6 $\mu\text{g/L}$.
 - The BioPod removed an average of 97% of dissolved zinc, with a mean influent concentration of 117 $\mu\text{g/L}$ and a mean effluent concentration of 4 $\mu\text{g/L}$.
 - The BioPod removed an average of 97% of total phosphorus, with a mean influent concentration of 2.52 mg/L and a mean effluent concentration of 0.066 mg/L. When total phosphorus influent concentrations were capped at the TAPE upper limit of 0.5 mg/L, calculations showed an average removal of 87%.

Other BioPod Related Issues to be Addressed by the Company:

1. None identified at this time.

Technology Description:

Download at
<https://oldcastleprecast.com/stormwater/bioretention-biofiltration-applications/bioretention-biofiltration-solutions/>

Contact Information:

Applicant: Chris Demarest
 Oldcastle Infrastructure, Inc.
 (925)667-7100
 Chris.demarest@oldcastle.com

Applicant website: <https://oldcastleprecast.com/stormwater/>

Ecology web link: <https://ecology.wa.gov/Regulations-Permits/Guidance-technical-assistance/Stormwater-permittee-guidance-resources/Emerging-stormwater-treatment-technologies>

Ecology: Douglas C. Howie, P.E.
 Department of Ecology
 Water Quality Program
 (360) 870-0983
douglas.howie@ecy.wa.gov

Revision History

Date	Revision
March 2018	GULD granted for Basic Treatment
March 2018	Provisional GULD granted for Enhanced and Phosphorus Treatment
June 2016	PULD Granted
April 2018	GULD for Basic and Provisional GULD for Enhanced and Phosphorus granted, changed name to BioPod from TreePod
July 2018	GULD for Enhanced and Phosphorus granted
September 2018	Changed Address for Oldcastle
December 2018	Added minimum media thickness requirement
May 2019	Changed language on who must Install and maintain the device from Oldcastle to Applicants
August 2019	Added text on sizing using infiltration rate and water quality design flow rate
October 2019	Added text describing ability to use off-line design water quality flow rate for sizing due to internal bypass
December 2021	Extended approval to installations without plants, added sizing adjustment when using facilities with a drawdown outlet
March 2022	Added results from the maintenance frequency assessment to the Ecology's Conditions of Use and the Findings of Fact sections

Analysis

Water Quality

On-Line BMP: 24 hour Volume (ac-ft) 0.3674
Standard Flow Rate (cfs) 0.4354

Off-Line BMP: Standard Flow Rate (cfs) 0.2847

Subbasin Name: Post-Developed Site

Flows To: Surface Interflow Groundwater

Area in Basin

Available Pervious	Acres	Available Impervious	Acres
<input checked="" type="checkbox"/> C_Lawn_Flat	0.83	<input checked="" type="checkbox"/> ROOF TOPS/FLAT	1.45
		<input checked="" type="checkbox"/> SIDEWALKS/FLAT	0.15
		<input checked="" type="checkbox"/> PARKING/FLAT	1.78

Evap POC 1 POC 2
All Datasets Flow Stage Precip

Flood Frequency Method
 Log Pearson Type III 178
 Weibull
 Cunnane
 Gingorten

Pervious Total 0.83 Acres
 Impervious Total 3.38 Acres
 Basin Total 4.21 Acres

Deselect Zero Select By: GO

8X16 BIOPOD PERFORMANCE SPECIFICATIONS WITH WQ FLOW CAPACITY HIGHLIGHTED. SEE FOLLOWING PAGE FOR FULL DETAIL FROM OLDCASTLE

PERFORMANCE SPECIFICATIONS	
Treatment Flow Capacities:*	
NJDEP 80% Removal, 75 micron	0.432 cfs
WA Ecology GULD - Basic, Enhanced & Phosphorus	0.384 cfs
Bypass Capacity	6.5 cfs

*Contact Oldcastle for alternative treatment flow capacities.

Post-Developed Site: 0.2847 CFS < 0.384 CFS

Flow Frequency		
Flow (cfs)	Predeveloped	Mitigated
2 Year	= 0.4387	1.2177
5 Year	= 0.5093	1.6472
10 Year	= 0.5525	1.9612
25 Year	= 0.6041	2.3931
50 Year	= 0.6409	2.7412
100 Year	= 0.6766	3.1127

100 year flow frequency does not exceed water quality devices bypass capacity.

Post-Developed Site: OFFLINE FLOW RATE = 0.2847 CFS

SITE SPECIFIC DATA				
Structure ID	ID			
Treatment Flow Rate (cfs)	-			
Peak Flow Rate (cfs)	-			
Rim Elevation	-			
Top of Vault Elevation	-			
Pipe Data	Pipe Location	Pipe Size	Pipe Type	Invert Elevation
Inlet	-	-	-	-
Outlet	-	-	-	-
Notes:				
PERFORMANCE SPECIFICATIONS				
Treatment Flow Capacities:*				
NJDEP 80% Removal, 75 micron	0.432 cfs			
WA Ecology GULD - Basic, Enhanced & Phosphorus	0.384 cfs			
Bypass Capacity	6.5 cfs			
*Contact Oldcastle for alternative treatment flow capacities.				

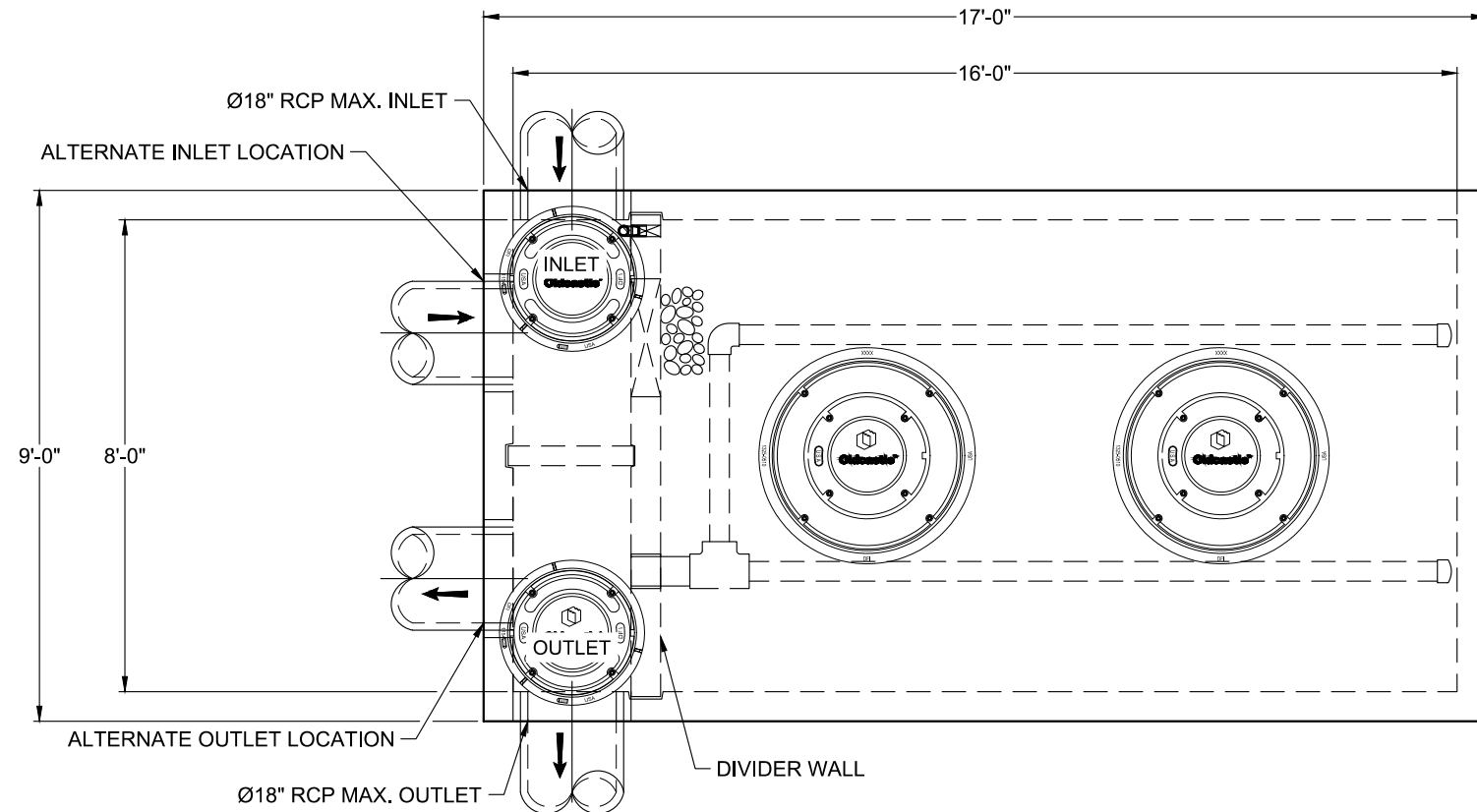

PLAN VIEW

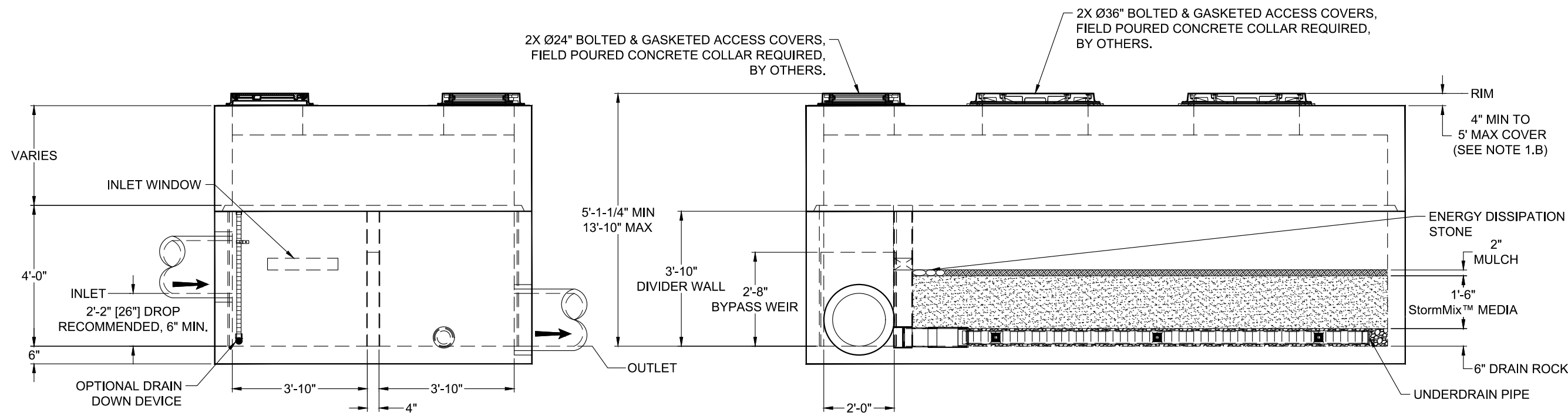

LEFT END VIEW

ELEVATION VIEW

- NOTES:
- DESIGN LOADINGS:
 - AASHTO HS-20-44 (WITH IMPACT)
 - DESIGN SOIL COVER: 5'-0" MAXIMUM
 - ASSUMED WATER TABLE: BELOW BASE OF PRECAST (ENGINEER-OF-RECORD TO CONFIRM SITE WATER TABLE ELEVATION)
 - LATERAL EARTH PRESSURE: 45 PCF (DRAINED)
 - LATERAL LIVE LOAD SURCHARGE: 80 PSF (APPLIED TO 8'-0" BELOW GRADE)
 - NO LATERAL SURCHARGE FROM ADJACENT BUILDINGS, WALLS, PIERS, OR FOUNDATIONS.
 - CONCRETE 28-DAY MINIMUM COMPRESSIVE STRENGTH: 5,000 PSI MINIMUM.
 - REINFORCING: REBAR, ASTM A615/A706, GRADE 60
 - CEMENT: ASTM C150
 - REQUIRED ALLOWABLE SOIL BEARING CAPACITY: 2,500 PSF
 - REFERENCE STANDARD:
 - ASTM C890
 - ASTM C913
 - ACI 318-14
 - THIS STRUCTURE IS DESIGNED TO THE PARAMETERS NOTED HEREIN. ENGINEER-OF-RECORD SHALL VERIFY THAT NOTED PARAMETERS MEET OR EXCEED PROJECT REQUIREMENTS. IF DESIGN PARAMETERS ARE INCORRECT, REVIEWING ENGINEER/AUTHORITY SHALL NOTIFY OLDCASTLE INFRASTRUCTURE UPON REVIEW.
 - INLET AND OUTLET HOLES WILL BE FACTORY CORED/CAST PER PLANS AND CUSTOMER REQUIREMENTS. INLET AND OUTLET LOCATIONS CAN BE MIRRORRED.
 - CONTRACTOR RESPONSIBLE TO VERIFY ALL SIZES, LOCATIONS, AND ELEVATIONS OF OPENINGS.
 - CONTRACTOR RESPONSIBLE TO ENSURE ADEQUATE BEARING SURFACE IS PROVIDED (I.E. COMPACTED AND LEVEL PER PROJECT SPECIFICATIONS).
 - SECTION HEIGHTS, SLAB/WALL THICKNESSES, AND KEYWAYS ARE SUBJECT TO CHANGE AS REQUIRED FOR SITE REQUIREMENTS AND/OR DUE TO PRODUCT AVAILABILITY AND PRODUCTION FACILITY CONSTRAINTS.
 - MAXIMUM PICK WEIGHTS*:
 - TOP: XX,XXX LBS
 - BASE: XX,XXX LBS* (* COMBINED WEIGHT OF BASE INCLUDES BYPASS WEIR, DIVIDER WALL, ROCK & MEDIA)
 - INTERNALS SHALL CONSIST OF UNDERDRAIN PIPE, ROCK, STORMMIX™ MEDIA, MULCH, DIVIDER WALL, BYPASS WEIR AND OPTIONAL DRAIN DOWN.

Oldcastle Infrastructure
A CRH COMPANY

Ph: 800.579.8819 | www.oldcastleinfrastructure.com/stormwater

THIS DOCUMENT IS THE PROPERTY OF OLDCASTLE INFRASTRUCTURE, INC. IT IS CONFIDENTIAL, SUBMITTED FOR REFERENCE PURPOSES ONLY AND SHALL NOT BE USED IN ANY WAY INJURIOUS TO THE INTERESTS OF, OR WITHOUT THE WRITTEN PERMISSION OF OLDCASTLE INFRASTRUCTURE, INC. COPYRIGHT © 2021 OLDCASTLE INFRASTRUCTURE, INC. ALL RIGHTS RESERVED.

BioPod™ Biofilter System (STANDARD)
Underground Vault with Internal Bypass

CUSTOMER: -

PROJECT NAME: -

SHEET NAME	REVISION	SHEET
Specifier Drawing BPU-8161B	REV DATE	1 OF 1

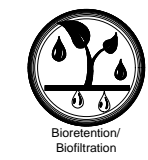

Project Description

File Name storm.SPF
 Description Q:\2023\2230491\10_CIV\CAD\2230491-W-STRM.dwg

Project Options

Flow Units CFS
 Elevation Type Elevation
 Hydrology Method Santa Barbara UH
 Time of Concentration (TOC) Method SCS TR-55
 Link Routing Method Hydrodynamic
 Enable Overflow Ponding at Nodes YES
 Skip Steady State Analysis Time Periods NO

Analysis Options

Start Analysis On 00:00:00 0:00:00
 End Analysis On 00:00:00 0:00:00
 Start Reporting On 00:00:00 0:00:00
 Antecedent Dry Days 0 days
 Runoff (Dry Weather) Time Step 0 01:00:00 days hh:mm:ss
 Runoff (Wet Weather) Time Step 0 00:05:00 days hh:mm:ss
 Reporting Time Step 0 00:05:00 days hh:mm:ss
 Routing Time Step 30 seconds

Number of Elements

	Qty
Rain Gages	1
Subbasins	16
Nodes	23
<i>Junctions</i>	22
<i>Outfalls</i>	1
<i>Flow Diversions</i>	0
<i>Inlets</i>	0
<i>Storage Nodes</i>	0
Links	22
<i>Channels</i>	0
<i>Pipes</i>	22
<i>Pumps</i>	0
<i>Orifices</i>	0
<i>Weirs</i>	0
<i>Outlets</i>	0
Pollutants	0
Land Uses	0

Rainfall Details

SN	Rain Gage ID	Data Source	Data Source ID	Rainfall Type	Rain Units	State	County	Return Period (years)	Rainfall Depth (inches)	Rainfall Distribution
1	Rain Gage-01	Time Series	TS-25 year storm	Intensity	inches	Washington	Pierce	25.00	3.50	SCS Type IA 24-hr

Subbasin Summary

SN	Subbasin ID	Area (ac)	Impervious Area (%)	Impervious Area Curve Number	Pervious Area Curve Number	Total Rainfall (in)	Total Runoff (in)	Total Runoff Volume (ac-in)	Peak Runoff (cfs)	Time of Concentration (days hh:mm:ss)
1	roofsdcdb10	0.34	100.00	98.00	76.00	3.49	3.26	1.11	0.28	0 00:05:00
2	roofsdcdb6	0.37	100.00	98.00	76.00	3.49	3.26	1.21	0.30	0 00:05:00
3	roofsdcob2	0.37	100.00	98.00	76.00	3.49	3.26	1.21	0.30	0 00:05:00
4	roofsdcob7	0.37	100.00	98.00	76.00	3.49	3.26	1.21	0.30	0 00:05:00
5	sdcb10	0.09	70.00	98.00	76.00	3.49	2.69	0.24	0.06	0 00:05:00
6	sdcb3	0.35	70.00	98.00	76.00	3.49	2.69	0.94	0.23	0 00:05:00
7	sdcb4	0.25	70.00	98.00	76.00	3.49	2.69	0.67	0.16	0 00:05:00
8	sdcb5	0.20	70.00	98.00	76.00	3.49	2.69	0.54	0.13	0 00:05:00
9	sdcb6	0.09	70.00	98.00	76.00	3.49	2.69	0.24	0.06	0 00:05:00
10	sdcb8	0.25	70.00	98.00	76.00	3.49	2.69	0.67	0.16	0 00:05:00
11	sdcb9	0.09	70.00	98.00	76.00	3.49	2.69	0.24	0.06	0 00:05:00
12	stcb500	0.23	70.00	98.00	76.00	3.49	2.69	0.62	0.15	0 00:05:00
13	stcb501	0.28	70.00	98.00	76.00	3.49	2.69	0.75	0.18	0 00:05:00
14	stcb502	0.38	70.00	98.00	76.00	3.49	2.69	1.02	0.25	0 00:05:00
15	stcb505	0.30	70.00	98.00	76.00	3.49	2.69	0.81	0.20	0 00:05:00
16	trench	0.25	25.00	98.00	76.00	3.49	1.83	0.46	0.10	0 00:05:00

Node Summary

SN	Element ID	Element Type	Invert Elevation (ft)	Ground/Rim (Max) Elevation (ft)	Initial Water Elevation (ft)	Surcharge Elevation (ft)	Ponded Area (ft ²)	Peak Inflow (cfs)	Max HGL Elevation (ft)	Max Surcharge Depth (ft)	Min Freeboard Attained (ft)	Time of Peak Flooding Occurrence (days hh:mm)	Total Flooded Volume (ac-in)	Total Time Flooded (min)
1	EX DRAIN OUTLET (STRM)	Junction	0.00	38.70	0.00	38.70	0.00	0.10	38.00	0.00	0.70	0 00:00	0.00	0.00
2	SDCB #1 (STRM)	Junction	33.31	41.90	33.31	41.90	0.00	2.82	34.14	0.00	7.76	0 00:00	0.00	0.00
3	SDCB #10 (STRM)	Junction	36.06	40.68	36.06	40.68	0.00	0.34	36.49	0.00	4.18	0 00:00	0.00	0.00
4	SDCB #3 (STRM)	Junction	35.36	38.42	35.36	38.42	0.00	1.08	35.84	0.00	2.58	0 00:00	0.00	0.00
5	SDCB #4 (STRM)	Junction	36.70	39.33	36.70	39.33	0.00	0.85	37.05	0.00	2.27	0 00:00	0.00	0.00
6	SDCB #5 (STRM)	Junction	37.72	41.53	37.72	41.53	0.00	0.69	38.05	0.00	3.48	0 00:00	0.00	0.00
7	SDCB #6 (STRM)	Junction	38.13	41.72	38.13	41.72	0.00	0.36	38.42	0.00	3.30	0 00:00	0.00	0.00
8	SDCB #8 (STRM)	Junction	33.98	39.00	33.98	39.00	0.00	1.14	34.54	0.00	4.46	0 00:00	0.00	0.00
9	SDCB #9 (STRM)	Junction	36.20	39.81	36.20	39.81	0.00	0.64	36.54	0.00	3.27	0 00:00	0.00	0.00
10	SDCO #11 (STRM)	Junction	36.59	41.79	36.59	41.79	0.00	0.00	36.59	0.00	5.19	0 00:00	0.00	0.00
11	SDCO #2 (STRM)	Junction	35.06	39.49	35.06	39.49	0.00	1.38	35.57	0.00	3.92	0 00:00	0.00	0.00
12	SDCO #7 (STRM)	Junction	33.72	40.04	33.72	40.04	0.00	1.44	34.35	0.00	5.69	0 00:00	0.00	0.00
13	STCB 500 (STRM)	Junction	38.06	41.41	38.06	41.41	0.00	0.15	38.31	0.00	3.11	0 00:00	0.00	0.00
14	STCB 501 (STRM)	Junction	37.52	41.50	37.52	41.50	0.00	0.33	37.84	0.00	3.66	0 00:00	0.00	0.00
15	STCB 502 (STRM)	Junction	36.95	41.09	36.95	41.09	0.00	0.58	37.33	0.00	3.76	0 00:00	0.00	0.00
16	STCB 505 (STRM)	Junction	38.43	41.38	38.43	41.38	0.00	0.20	38.69	0.00	2.70	0 00:00	0.00	0.00
17	STMH 2263 (STRM)	Junction	31.04	41.03	31.04	41.03	0.00	2.81	31.56	0.00	9.47	0 00:00	0.00	0.00
18	STMH 503 (STRM)	Junction	35.54	43.59	35.54	43.59	0.00	0.34	35.90	0.00	7.69	0 00:00	0.00	0.00
19	STMH 504 (STRM)	Junction	35.83	41.98	35.83	41.98	0.00	0.34	36.19	0.00	5.79	0 00:00	0.00	0.00
20	STMH 580 (STRM)	Junction	35.12	43.27	35.12	43.27	0.00	0.34	35.41	0.00	7.87	0 00:00	0.00	0.00
21	STMH 998 (STRM)	Junction	34.14	39.96	34.14	39.96	0.00	0.34	34.58	0.00	5.37	0 00:00	0.00	0.00
22	WQ OUTLET (STRM)	Junction	31.15	41.91	31.15	32.25	0.00	2.81	31.87	0.00	10.04	0 00:00	0.00	0.00
23	STMH 2262 (STRM)	Outfall	30.40					2.81	30.78					

FREEBOARD > 0.5 FEET

Link Summary

SN Element ID	Element Type	From (Inlet) Node	To (Outlet) Node	Length (ft)	Inlet Invert Elevation (ft)	Outlet Invert Elevation (ft)	Average Slope (%)	Diameter or Height (in)	Manning's Roughness	Peak Flow (cfs)	Design Flow Capacity (cfs)	Peak Flow/Design Flow Ratio	Peak Flow Velocity (ft/sec)	Peak Flow Depth (ft)	Peak Flow Depth/Total Depth Ratio	Total Time Reported Surcharged Condition (min)
1 {STRM}.EX PIPE 1 (STRM)	Pipe	STMH 2263 (STRM)	STMH 2262 (STRM)	17.41	31.04	30.40	3.6800	18.000	0.0130	2.81	20.14	0.14	6.37	0.45	0.30	0.00 Calculated
2 {STRM}.EX PIPE 2 (STRM)	Pipe	STMH 998 (STRM)	STMH 580 (STRM)	187.64	34.14	35.12	-0.5200	8.004	0.0130	0.34	0.87	0.38	1.75	0.36	0.55	0.00 Calculated
3 {STRM}.EX PIPE 3 (STRM)	Pipe	STMH 580 (STRM)	STMH 503 (STRM)	114.10	35.17	35.54	-0.3200	8.004	0.0130	0.34	0.69	0.49	2.08	0.31	0.47	0.00 Calculated
4 {STRM}.EX PIPE 4 (STRM)	Pipe	STMH 503 (STRM)	STMH 504 (STRM)	78.85	35.59	35.83	-0.3000	8.004	0.0130	0.34	0.67	0.50	1.90	0.34	0.51	0.00 Calculated
5 {STRM}.EX PIPE 5 (STRM)	Pipe	STMH 504 (STRM)	SDCB #10 (STRM)	46.30	35.88	36.06	-0.3900	6.000	0.0130	0.34	0.35	0.96	2.14	0.37	0.75	0.00 Calculated
6 {STRM}.EX PIPE 6 (STRM)	Pipe	STCB 502 (STRM)	STCB 501 (STRM)	165.77	36.95	37.52	-0.3400	8.004	0.0130	0.33	0.71	0.47	1.80	0.35	0.52	0.00 Calculated
7 {STRM}.EX PIPE 7 (STRM)	Pipe	STCB 501 (STRM)	STCB 500 (STRM)	116.66	37.75	38.06	-0.2700	8.004	0.0130	0.15	0.62	0.24	1.58	0.21	0.32	0.00 Calculated
8 {STRM}.EX PIPE 8 (STRM)	Pipe	STCB 505 (STRM)	SDCB #5 (STRM)	262.01	38.43	37.72	0.2700	8.004	0.0130	0.20	0.63	0.31	1.32	0.29	0.44	0.00 Calculated
9 {STRM}.PIPE 1 (STRM)	Pipe	WQ OUTLET (STRM)	STMH 2263 (STRM)	21.85	31.15	31.04	0.5000	18.000	0.0130	2.81	7.45	0.38	4.11	0.62	0.41	0.00 Calculated
10 {STRM}.PIPE 10 (STRM)	Pipe	SDCB #8 (STRM)	SDCO #7 (STRM)	51.37	33.98	33.72	0.5000	12.000	0.0130	1.14	2.52	0.45	2.35	0.59	0.59	0.00 Calculated
11 {STRM}.PIPE 11 (STRM)	Pipe	SDCB #8 (STRM)	STMH 998 (STRM)	31.66	33.98	34.14	-0.5000	8.004	0.0130	0.34	0.85	0.39	1.25	0.50	0.75	0.00 Calculated
12 {STRM}.PIPE 12 (STRM)	Pipe	SDCB #9 (STRM)	SDCB #8 (STRM)	46.98	36.20	35.85	0.7500	12.000	0.0130	0.64	3.08	0.21	2.89	0.32	0.32	0.00 Calculated
13 {STRM}.PIPE 13 (STRM)	Pipe	EX DRAIN OUTLET (STRM)	SDCB #9 (STRM)	15.80	37.95	36.20	11.0800	8.004	0.0130	0.05	4.03	0.01	0.88	0.17	0.25	0.00 Calculated
14 {STRM}.PIPE 14 (STRM)	Pipe	STCB 502 (STRM)	SDCB #9 (STRM)	99.83	36.95	36.20	0.7500	8.004	0.0130	0.58	1.05	0.55	2.96	0.37	0.55	0.00 Calculated
15 {STRM}.PIPE 15 (STRM)	Pipe	SDCO #11 (STRM)	SDCB #10 (STRM)	71.16	36.59	36.06	0.7500	8.004	0.0130	0.00	1.05	0.00	0.00	0.22	0.33	0.00 Calculated
16 {STRM}.PIPE 2 (STRM)	Pipe	SDCB #1 (STRM)	WQ OUTLET (STRM)	6.13	33.31	33.28	0.4900	18.000	0.0130	2.81	7.35	0.38	3.28	0.73	0.49	0.00 Calculated
17 {STRM}.PIPE 4 (STRM)	Pipe	SDCO #2 (STRM)	SDCB #1 (STRM)	118.14	35.06	34.18	0.7500	12.000	0.0130	1.38	3.08	0.45	3.64	0.49	0.49	0.00 Calculated
18 {STRM}.PIPE 5 (STRM)	Pipe	SDCB #3 (STRM)	SDCO #2 (STRM)	39.70	35.36	35.06	0.7500	12.000	0.0130	1.08	3.08	0.35	2.80	0.49	0.49	0.00 Calculated
19 {STRM}.PIPE 6 (STRM)	Pipe	SDCB #4 (STRM)	SDCB #3 (STRM)	170.58	36.70	35.36	0.7900	12.000	0.0130	0.85	3.16	0.27	2.72	0.42	0.42	0.00 Calculated
20 {STRM}.PIPE 7 (STRM)	Pipe	SDCB #4 (STRM)	SDCB #5 (STRM)	136.20	36.70	37.72	-0.7500	12.000	0.0130	0.69	3.09	0.22	2.88	0.34	0.34	0.00 Calculated
21 {STRM}.PIPE 8 (STRM)	Pipe	SDCB #6 (STRM)	SDCB #5 (STRM)	55.28	38.13	37.72	0.7500	8.004	0.0130	0.36	1.05	0.35	2.30	0.31	0.46	0.00 Calculated
22 {STRM}.PIPE 9 (STRM)	Pipe	SDCO #7 (STRM)	SDCB #1 (STRM)	82.45	33.72	33.31	0.5000	12.000	0.0130	1.44	2.52	0.57	2.34	0.73	0.73	0.00 Calculated

PEAK FLOW < DESIGN FLOW

Subbasin Hydrology

Subbasin : roofsdcb10

Input Data

Area (ac) 0.34
Impervious Area (%) 100
Impervious Area Curve Number 98
Pervious Area Curve Number 76
Rain Gage ID Rain Gage-01

Composite Curve Number

Soil/Surface Description	Area (acres)	Soil Group	Curve Number
32			
Composite Area & Weighted CN	0.34		98

Time of Concentration

TOC Method : SCS TR-55

Sheet Flow Equation :

$$T_c = (0.007 * ((n * L_f)^{0.8}) / ((P^{0.5}) * (S_f^{0.4})))$$

Where :

T_c = Time of Concentration (hr)
n = Manning's roughness
L_f = Flow Length (ft)
P = 2 yr, 24 hr Rainfall (inches)
S_f = Slope (ft/ft)

Shallow Concentrated Flow Equation :

V = 16.1345 * (S_f^{0.5}) (unpaved surface)
V = 20.3282 * (S_f^{0.5}) (paved surface)
V = 15.0 * (S_f^{0.5}) (grassed waterway surface)
V = 10.0 * (S_f^{0.5}) (nearly bare & untilled surface)
V = 9.0 * (S_f^{0.5}) (cultivated straight rows surface)
V = 7.0 * (S_f^{0.5}) (short grass pasture surface)
V = 5.0 * (S_f^{0.5}) (woodland surface)
V = 2.5 * (S_f^{0.5}) (forest w/heavy litter surface)
T_c = (L_f / V) / (3600 sec/hr)

Where:

T_c = Time of Concentration (hr)
L_f = Flow Length (ft)
V = Velocity (ft/sec)
S_f = Slope (ft/ft)

Channel Flow Equation :

V = (1.49 * (R^{2/3}) * (S_f^{0.5})) / n
R = A_q / W_p
T_c = (L_f / V) / (3600 sec/hr)

Where :

T_c = Time of Concentration (hr)
L_f = Flow Length (ft)
R = Hydraulic Radius (ft)
A_q = Flow Area (ft²)
W_p = Wetted Perimeter (ft)
V = Velocity (ft/sec)
S_f = Slope (ft/ft)
n = Manning's roughness

Subbasin Runoff Results

Total Rainfall (in)	3.49
Total Runoff (in)	3.26
Peak Runoff (cfs)	0.28
Weighted Curve Number	98
Time of Concentration (days hh:mm:ss)	0 00:00:00

Subbasin : roofsdcb10

Rainfall Intensity Graph

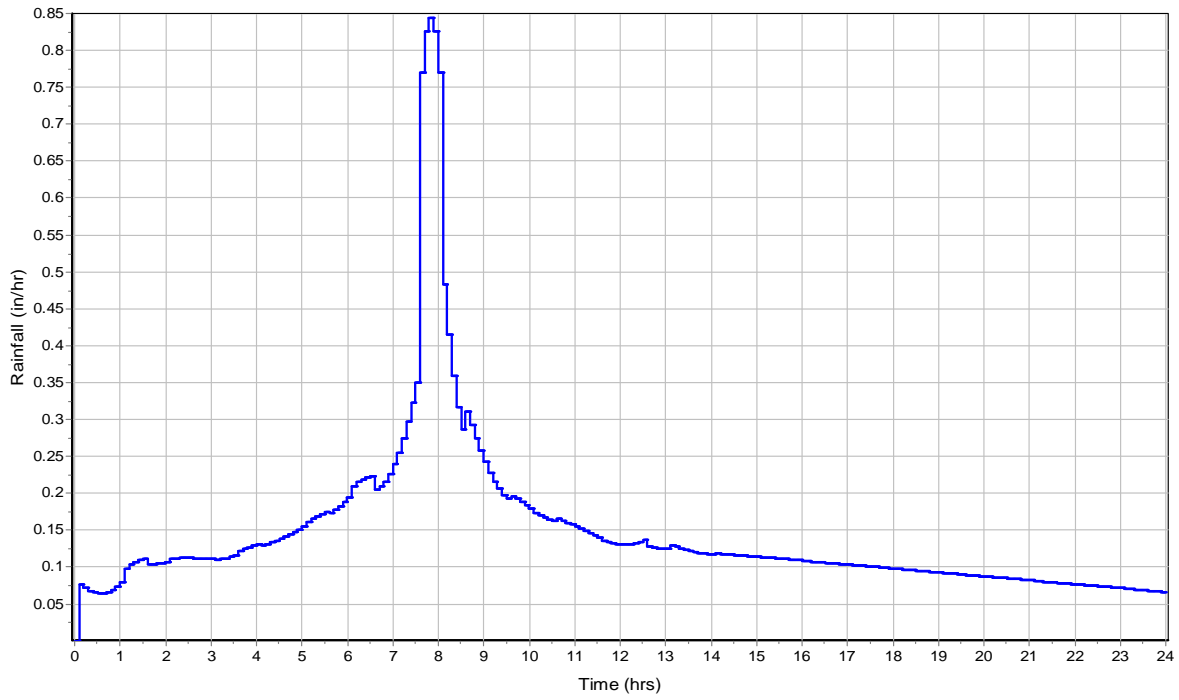

Runoff Hydrograph

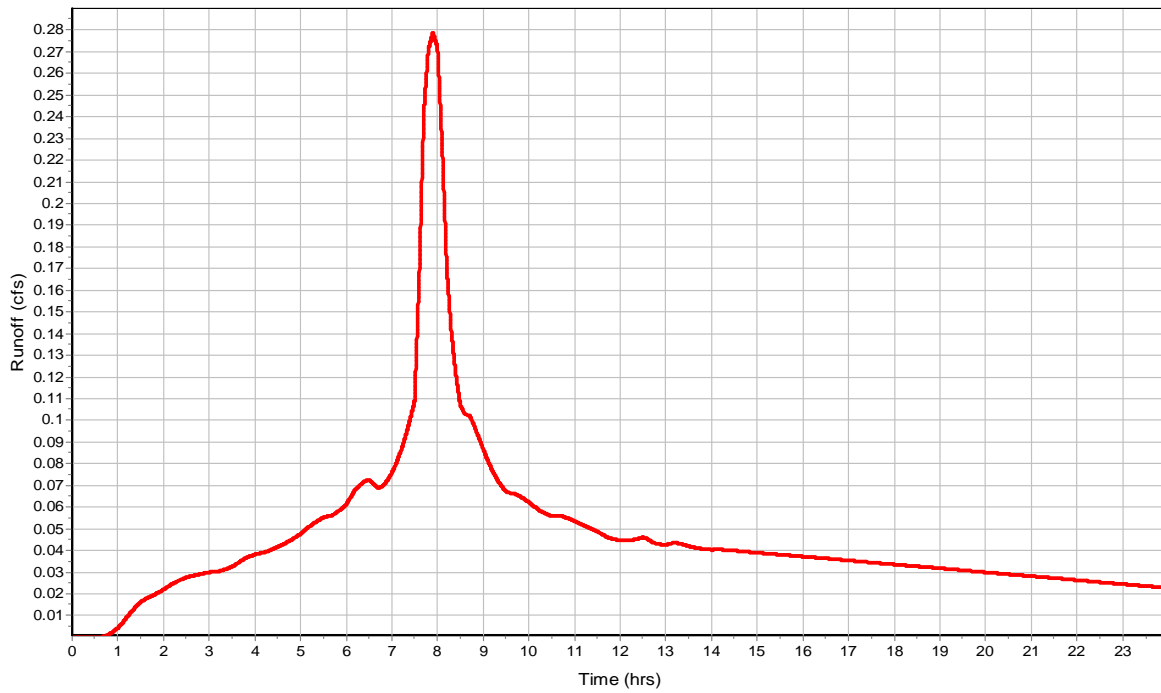

Subbasin : roofdcb6

Input Data

Area (ac) 0.37
Impervious Area (%) 100
Impervious Area Curve Number 98
Pervious Area Curve Number 76
Rain Gage ID Rain Gage-01

Composite Curve Number

32	Area	Soil	Curve
Soil/Surface Description	(acres)	Group	Number
Composite Area & Weighted CN	0.37		98

Time of Concentration

Subbasin Runoff Results

Total Rainfall (in) 3.49
Total Runoff (in) 3.26
Peak Runoff (cfs) 0.3
Weighted Curve Number 98
Time of Concentration (days hh:mm:ss) 0 00:00:00

Subbasin : roofsdcb6

Rainfall Intensity Graph

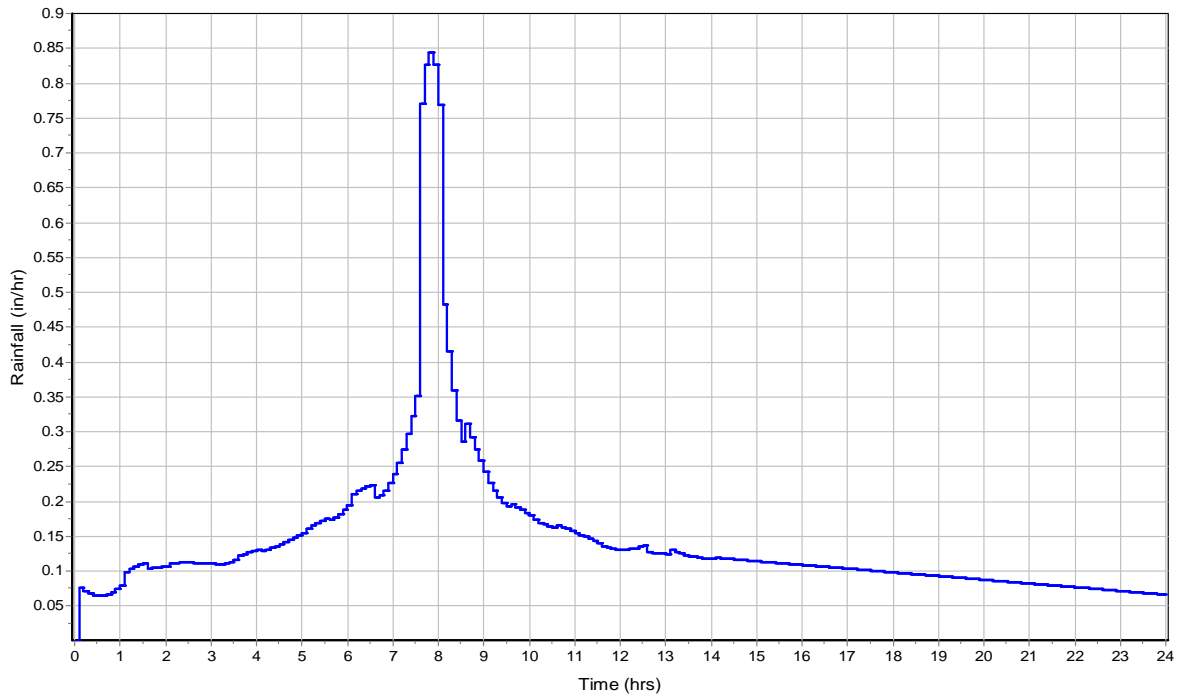

Runoff Hydrograph

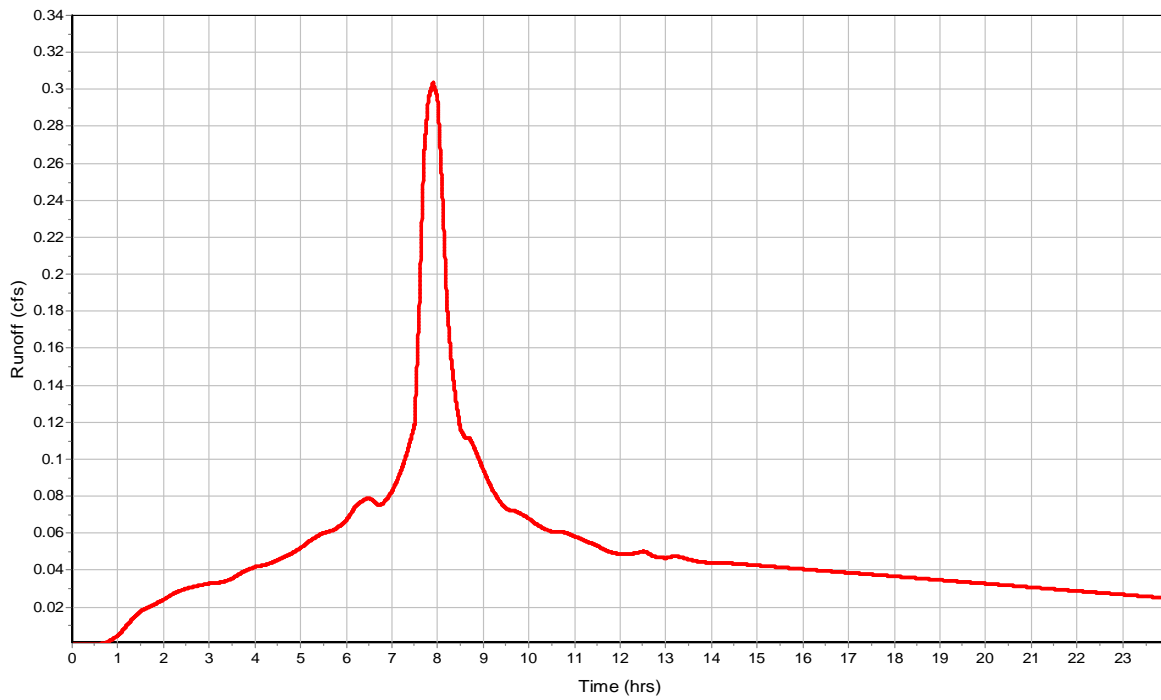

Subbasin : roofsdco2

Input Data

Area (ac) 0.37
Impervious Area (%) 100
Impervious Area Curve Number 98
Pervious Area Curve Number 76
Rain Gage ID Rain Gage-01

Composite Curve Number

32	Area	Soil	Curve
Soil/Surface Description	(acres)	Group	Number
Composite Area & Weighted CN	0.37		98

Time of Concentration

Subbasin Runoff Results

Total Rainfall (in) 3.49
Total Runoff (in) 3.26
Peak Runoff (cfs) 0.3
Weighted Curve Number 98
Time of Concentration (days hh:mm:ss) 0 00:00:00

Subbasin : roofsdco2

Rainfall Intensity Graph

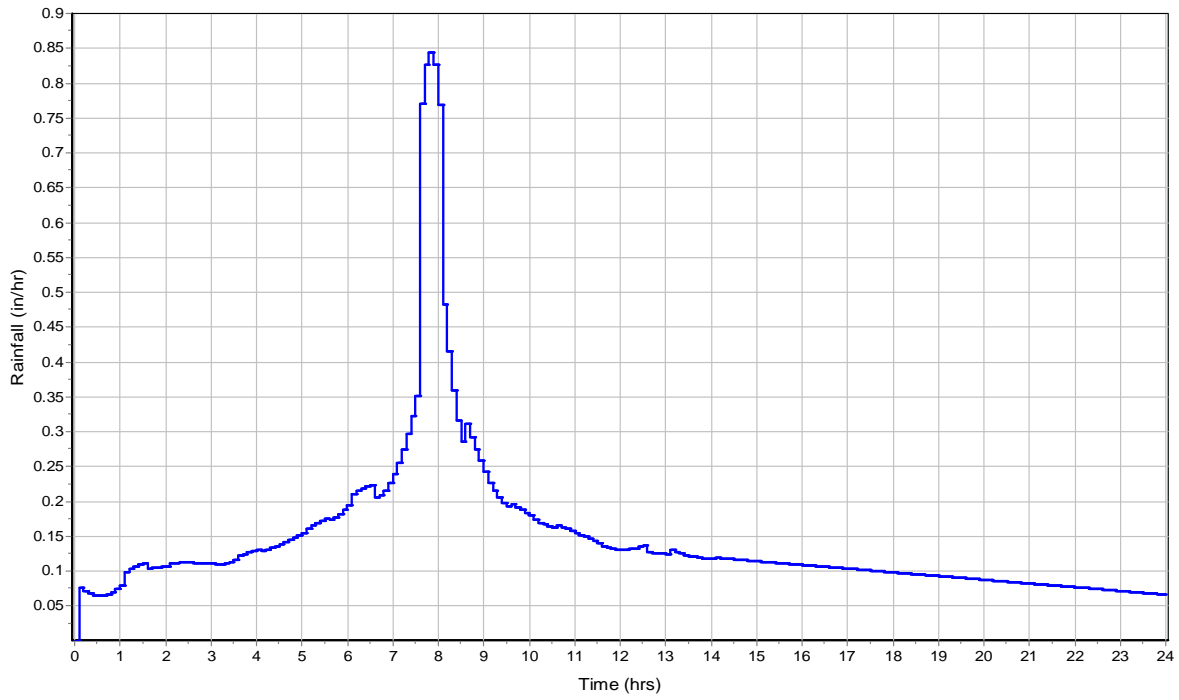

Runoff Hydrograph

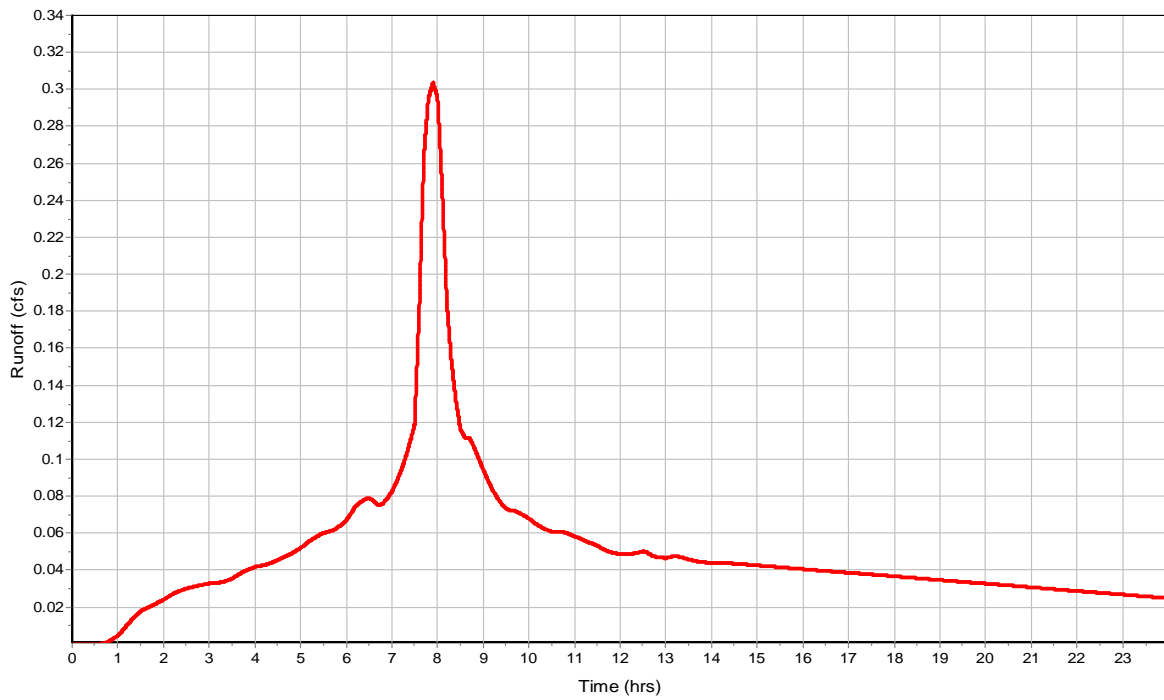

Subbasin : roofdco7

Input Data

Area (ac) 0.37
Impervious Area (%) 100
Impervious Area Curve Number 98
Pervious Area Curve Number 76
Rain Gage ID Rain Gage-01

Composite Curve Number

32	Area	Soil	Curve
Soil/Surface Description	(acres)	Group	Number
Composite Area & Weighted CN	0.37		98

Time of Concentration

Subbasin Runoff Results

Total Rainfall (in) 3.49
Total Runoff (in) 3.26
Peak Runoff (cfs) 0.3
Weighted Curve Number 98
Time of Concentration (days hh:mm:ss) 0 00:00:00

Subbasin : roofsdco7

Rainfall Intensity Graph

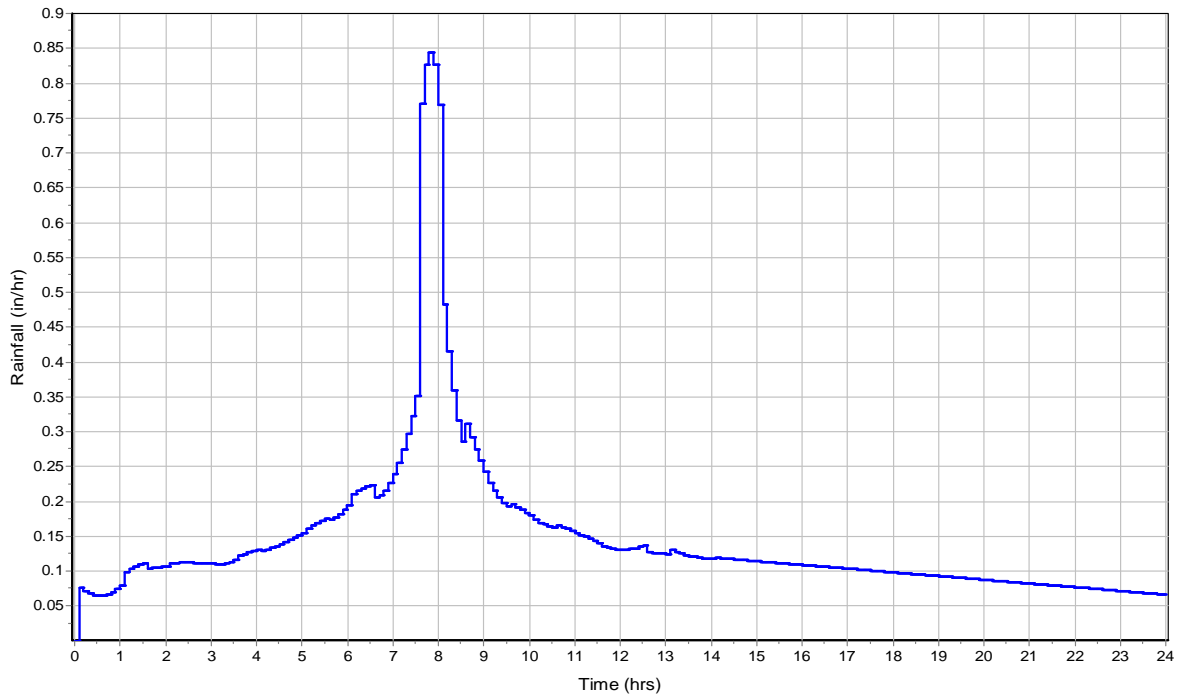

Runoff Hydrograph

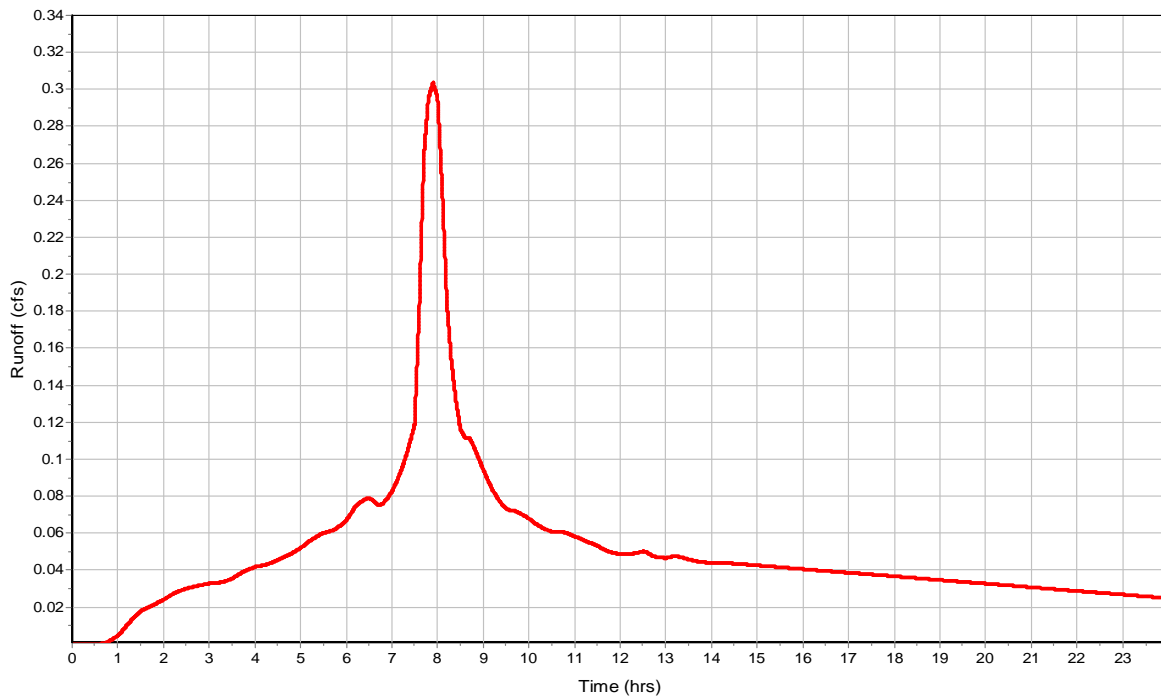

Subbasin : sdc10

Input Data

Area (ac) 0.09
Impervious Area (%) 70
Impervious Area Curve Number 98
Pervious Area Curve Number 76
Rain Gage ID Rain Gage-01

Composite Curve Number

32	Area	Soil	Curve
Soil/Surface Description	(acres)	Group	Number
Composite Area & Weighted CN	0.09		91.4

Time of Concentration

Subbasin Runoff Results

Total Rainfall (in) 3.49
Total Runoff (in) 2.69
Peak Runoff (cfs) 0.06
Weighted Curve Number 91.4
Time of Concentration (days hh:mm:ss) 0 00:00:00

Subbasin : sdc10

Rainfall Intensity Graph

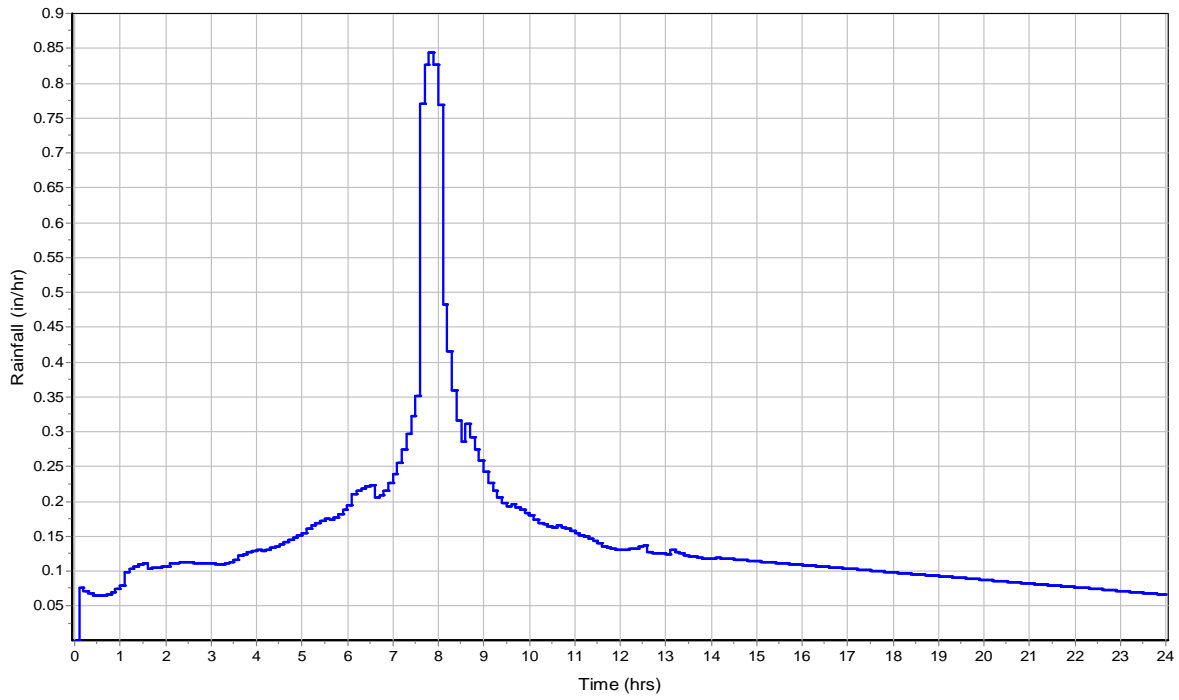

Runoff Hydrograph

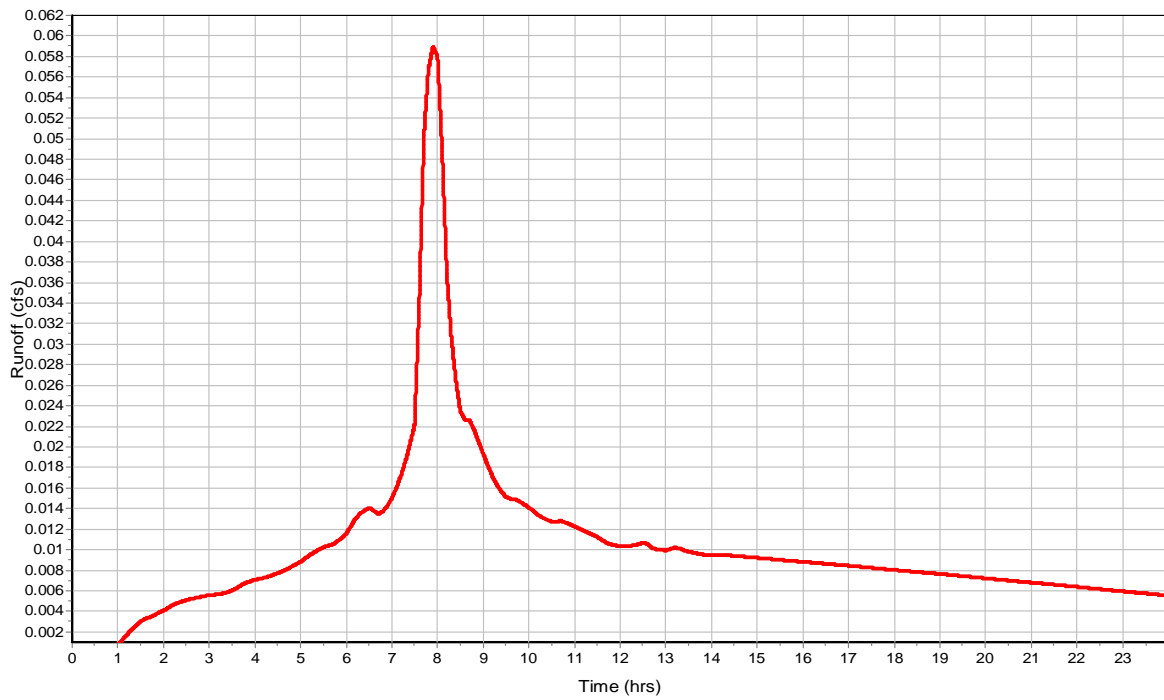

Subbasin : sdc3

Input Data

Area (ac) 0.35
Impervious Area (%) 70
Impervious Area Curve Number 98
Pervious Area Curve Number 76
Rain Gage ID Rain Gage-01

Composite Curve Number

32	Area	Soil	Curve
Soil/Surface Description	(acres)	Group	Number
Composite Area & Weighted CN	0.35		91.4

Time of Concentration

Subbasin Runoff Results

Total Rainfall (in) 3.49
Total Runoff (in) 2.69
Peak Runoff (cfs) 0.23
Weighted Curve Number 91.4
Time of Concentration (days hh:mm:ss) 0 00:00:00

Subbasin : sdc3

Rainfall Intensity Graph

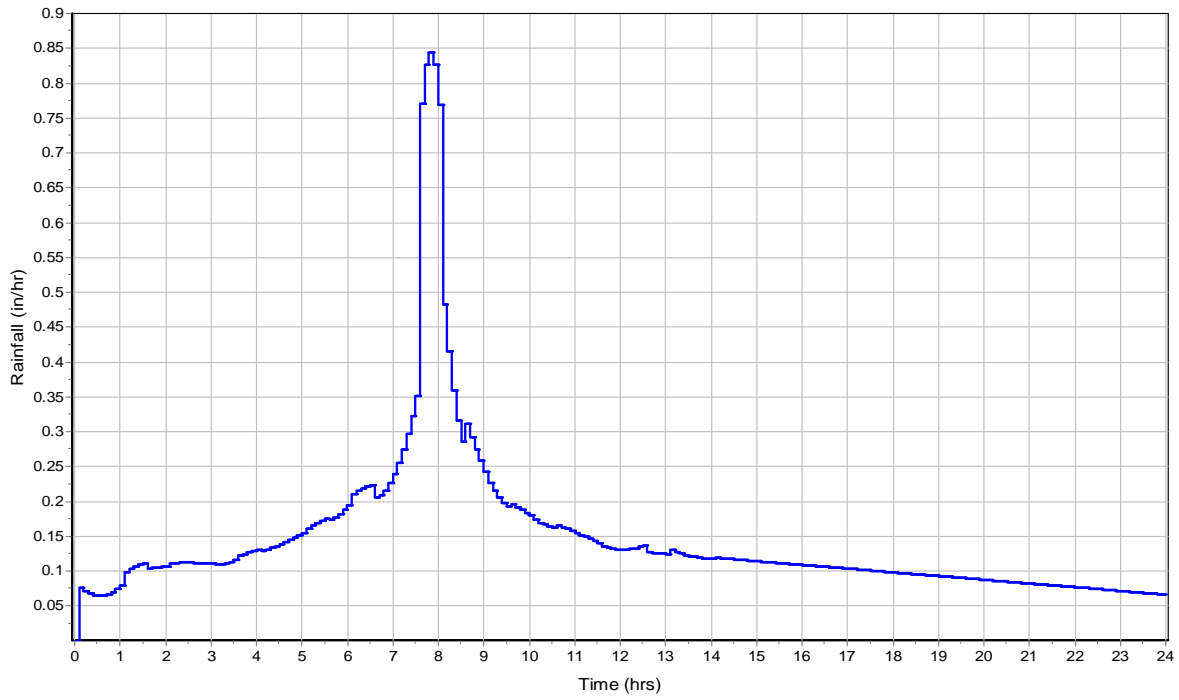

Runoff Hydrograph

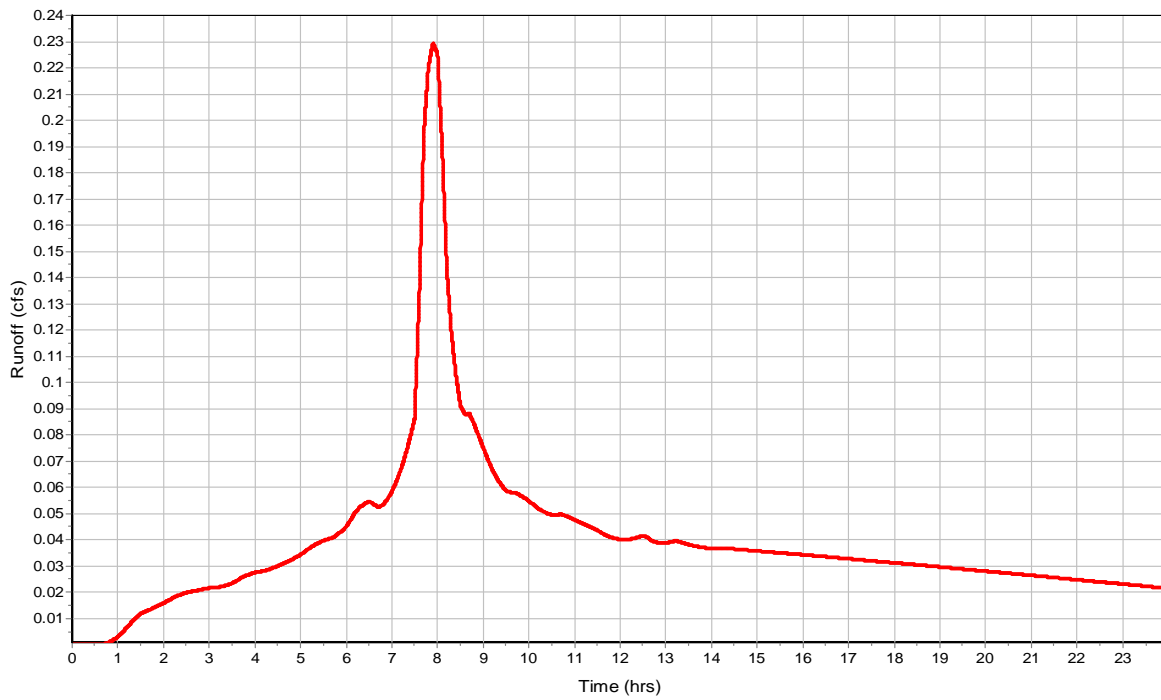

Subbasin : sdc4

Input Data

Area (ac) 0.25
Impervious Area (%) 70
Impervious Area Curve Number 98
Pervious Area Curve Number 76
Rain Gage ID Rain Gage-01

Composite Curve Number

32	Area	Soil	Curve
Soil/Surface Description	(acres)	Group	Number
Composite Area & Weighted CN	0.25		91.4

Time of Concentration

Subbasin Runoff Results

Total Rainfall (in) 3.49
Total Runoff (in) 2.69
Peak Runoff (cfs) 0.16
Weighted Curve Number 91.4
Time of Concentration (days hh:mm:ss) 0 00:00:00

Subbasin : sdc4

Rainfall Intensity Graph

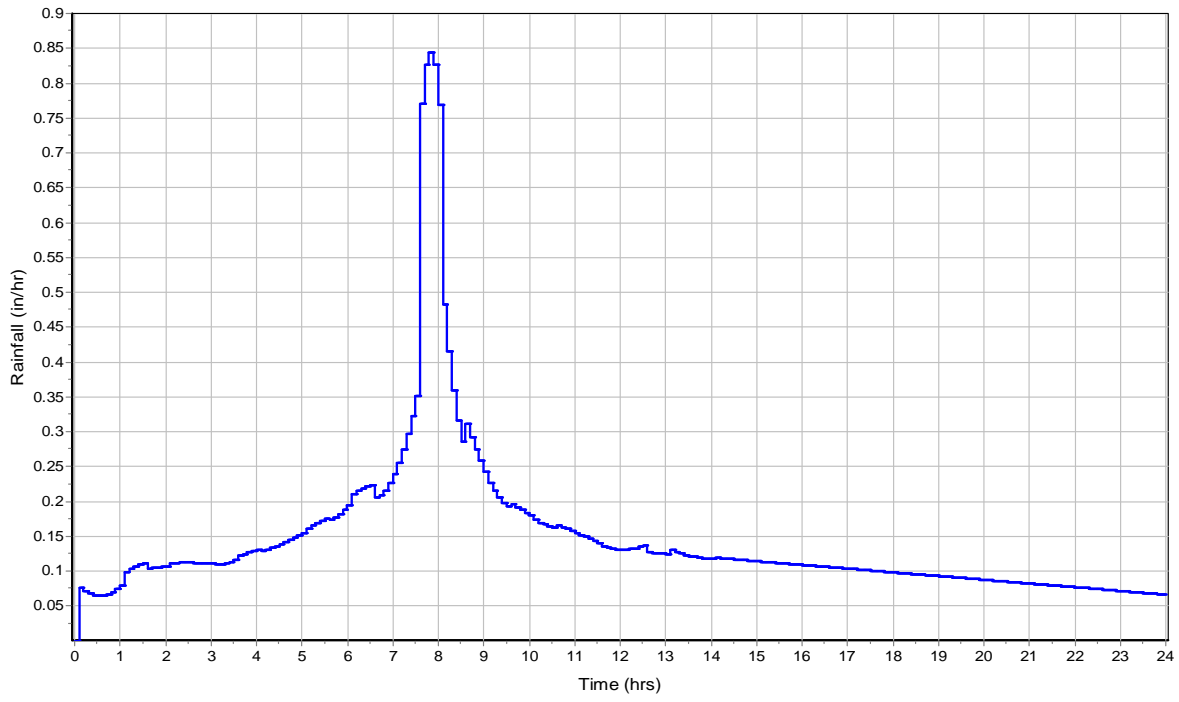

Runoff Hydrograph

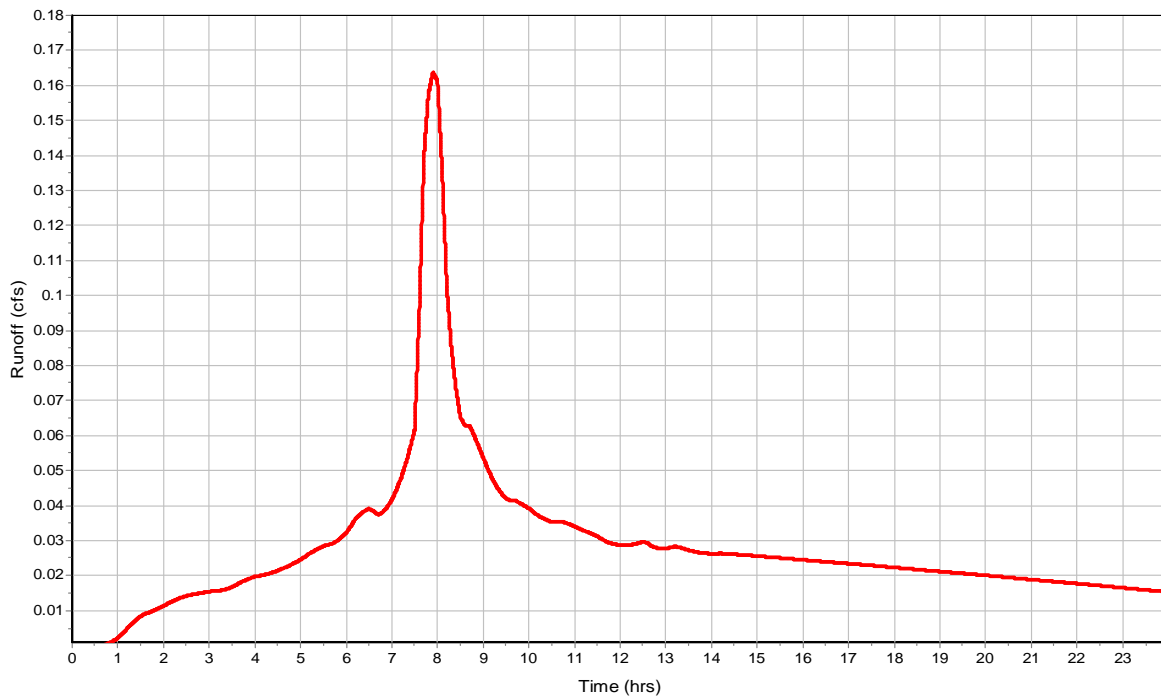

Subbasin : sdc5

Input Data

Area (ac) 0.2
Impervious Area (%) 70
Impervious Area Curve Number 98
Pervious Area Curve Number 76
Rain Gage ID Rain Gage-01

Composite Curve Number

32	Area	Soil	Curve
Soil/Surface Description	(acres)	Group	Number
Composite Area & Weighted CN	0.2		91.4

Time of Concentration

Subbasin Runoff Results

Total Rainfall (in) 3.49
Total Runoff (in) 2.69
Peak Runoff (cfs) 0.13
Weighted Curve Number 91.4
Time of Concentration (days hh:mm:ss) 0 00:00:00

Subbasin : sdc5

Rainfall Intensity Graph

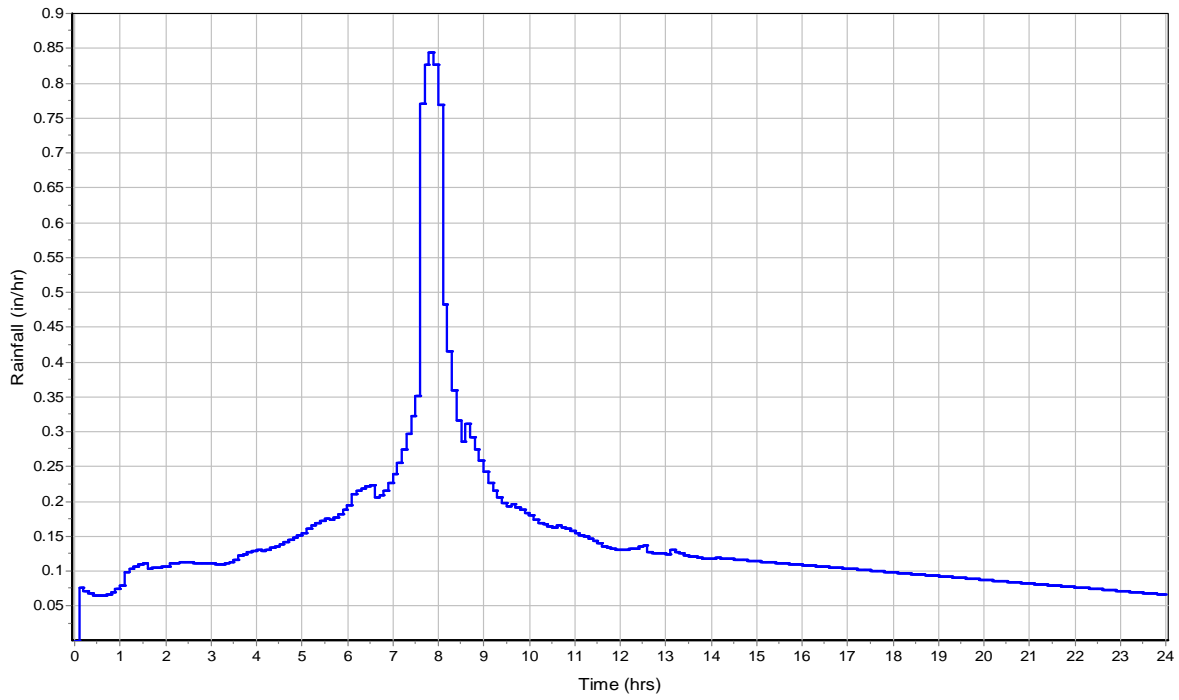

Runoff Hydrograph

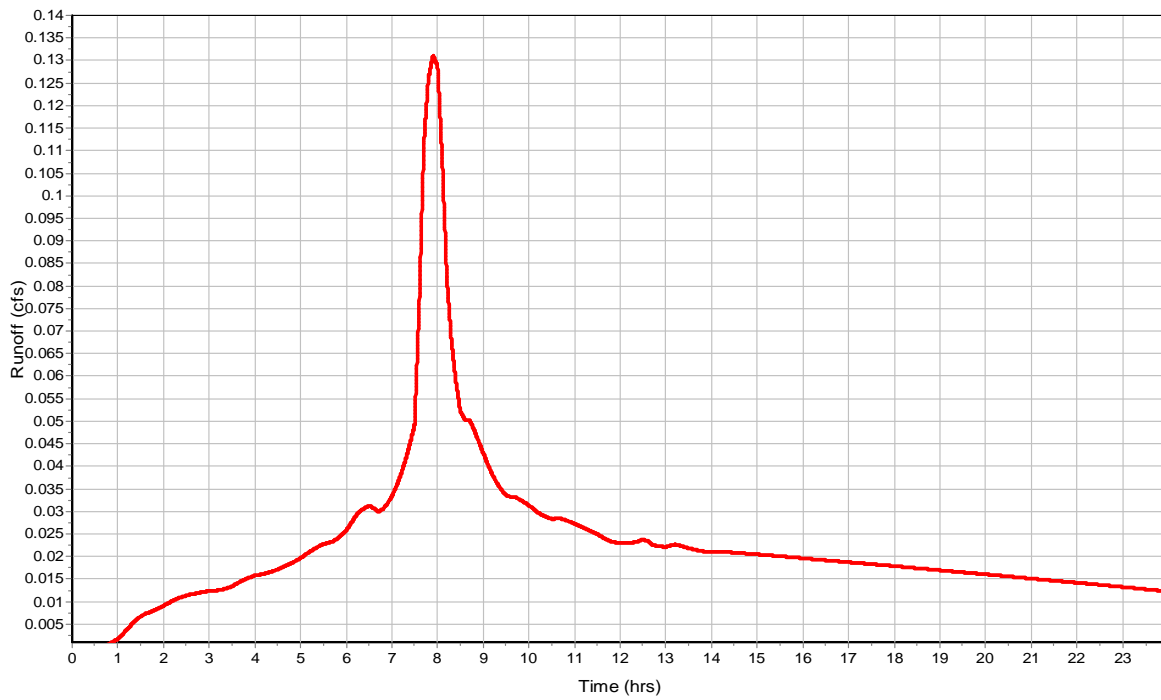

Subbasin : sdc6

Input Data

Area (ac) 0.09
Impervious Area (%) 70
Impervious Area Curve Number 98
Pervious Area Curve Number 76
Rain Gage ID Rain Gage-01

Composite Curve Number

32	Area	Soil	Curve
Soil/Surface Description	(acres)	Group	Number
Composite Area & Weighted CN	0.09		91.4

Time of Concentration

Subbasin Runoff Results

Total Rainfall (in) 3.49
Total Runoff (in) 2.69
Peak Runoff (cfs) 0.06
Weighted Curve Number 91.4
Time of Concentration (days hh:mm:ss) 0 00:00:00

Subbasin : sdc6

Rainfall Intensity Graph

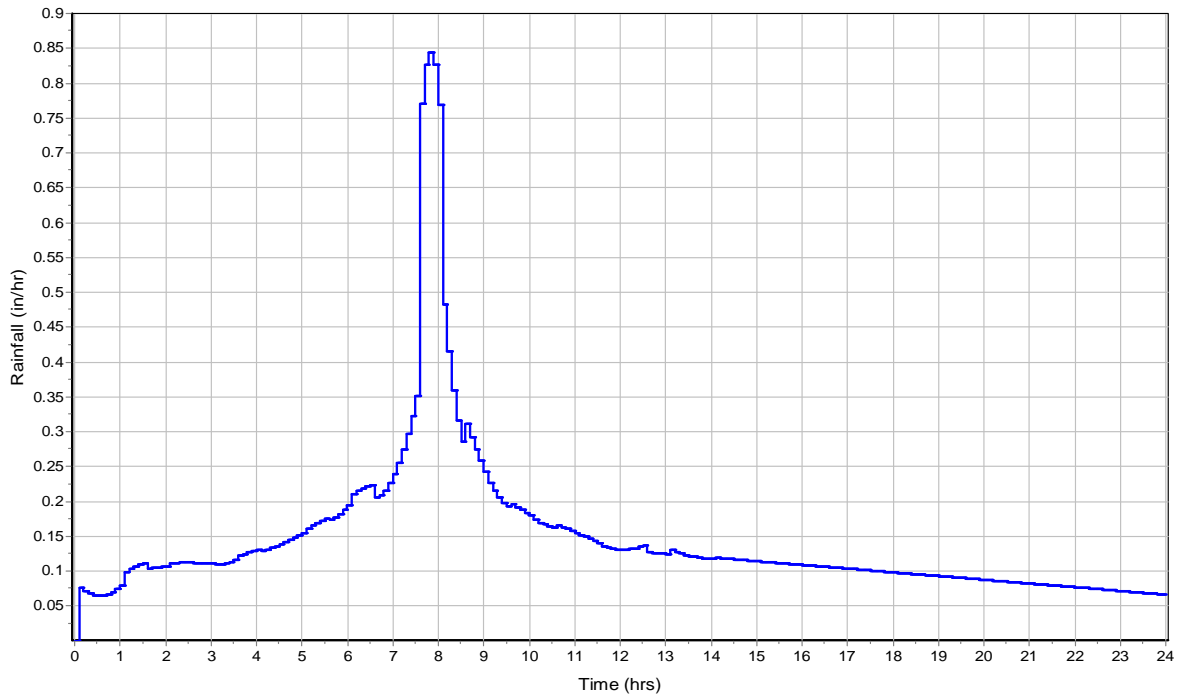

Runoff Hydrograph

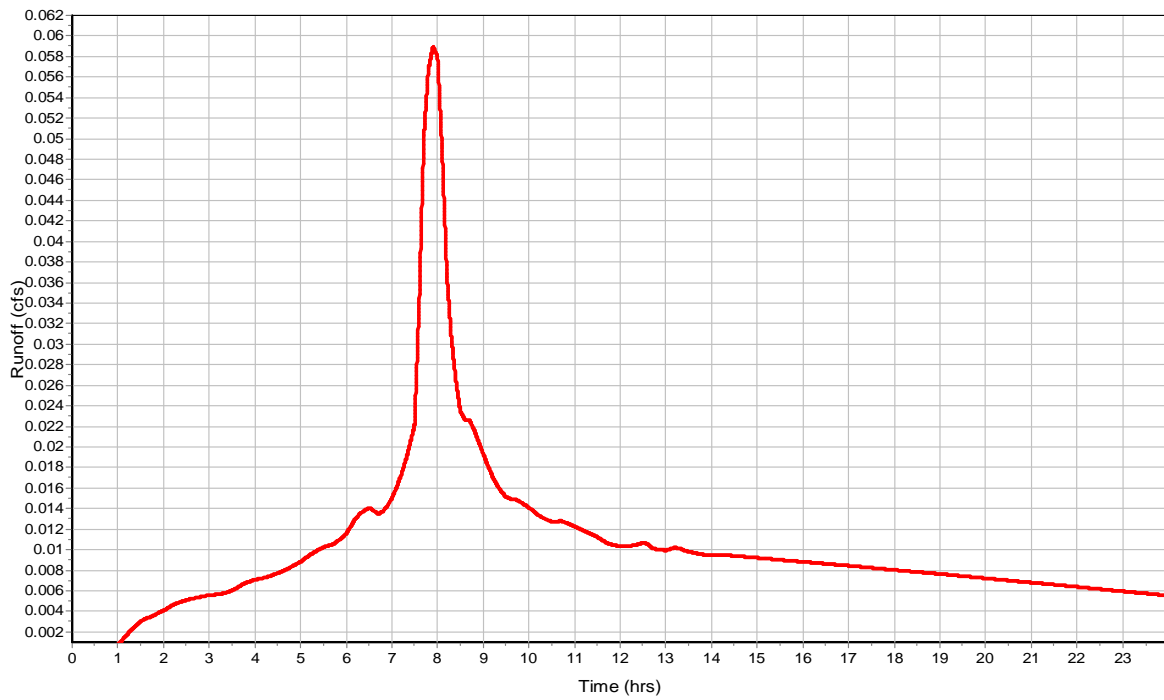

Subbasin : sdc8

Input Data

Area (ac) 0.25
Impervious Area (%) 70
Impervious Area Curve Number 98
Pervious Area Curve Number 76
Rain Gage ID Rain Gage-01

Composite Curve Number

32	Area	Soil	Curve
Soil/Surface Description	(acres)	Group	Number
Composite Area & Weighted CN	0.25		91.4

Time of Concentration

Subbasin Runoff Results

Total Rainfall (in) 3.49
Total Runoff (in) 2.69
Peak Runoff (cfs) 0.16
Weighted Curve Number 91.4
Time of Concentration (days hh:mm:ss) 0 00:00:00

Subbasin : sdc8

Rainfall Intensity Graph

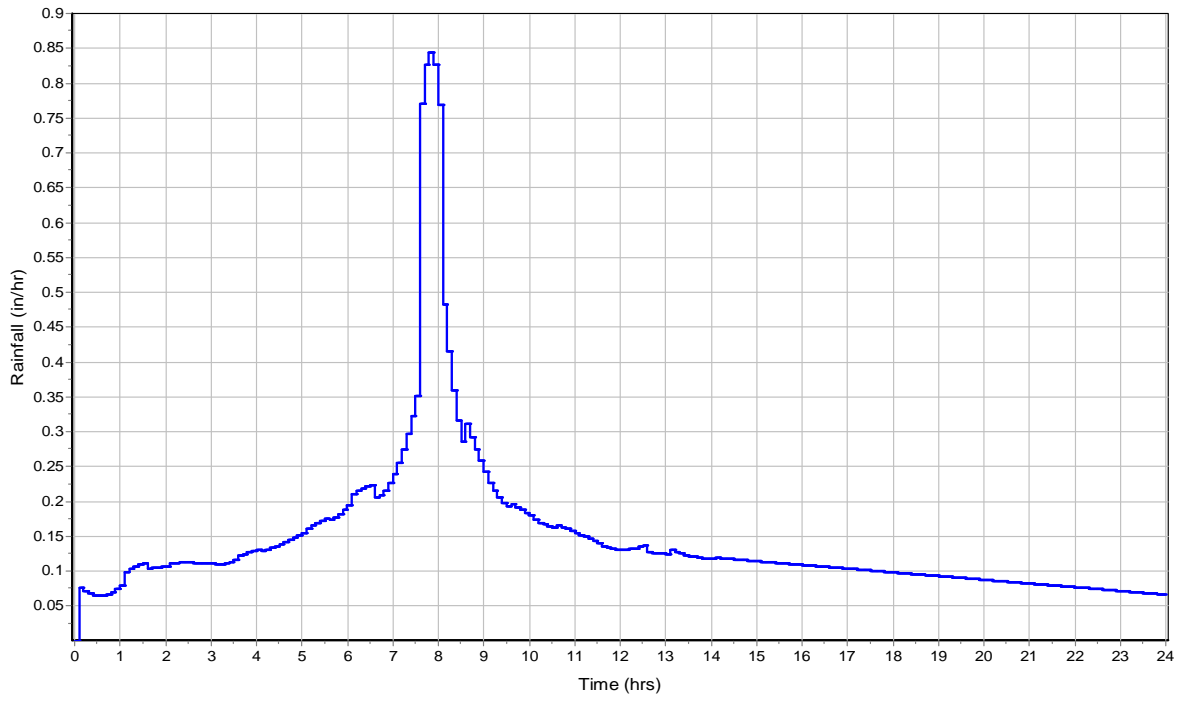

Runoff Hydrograph

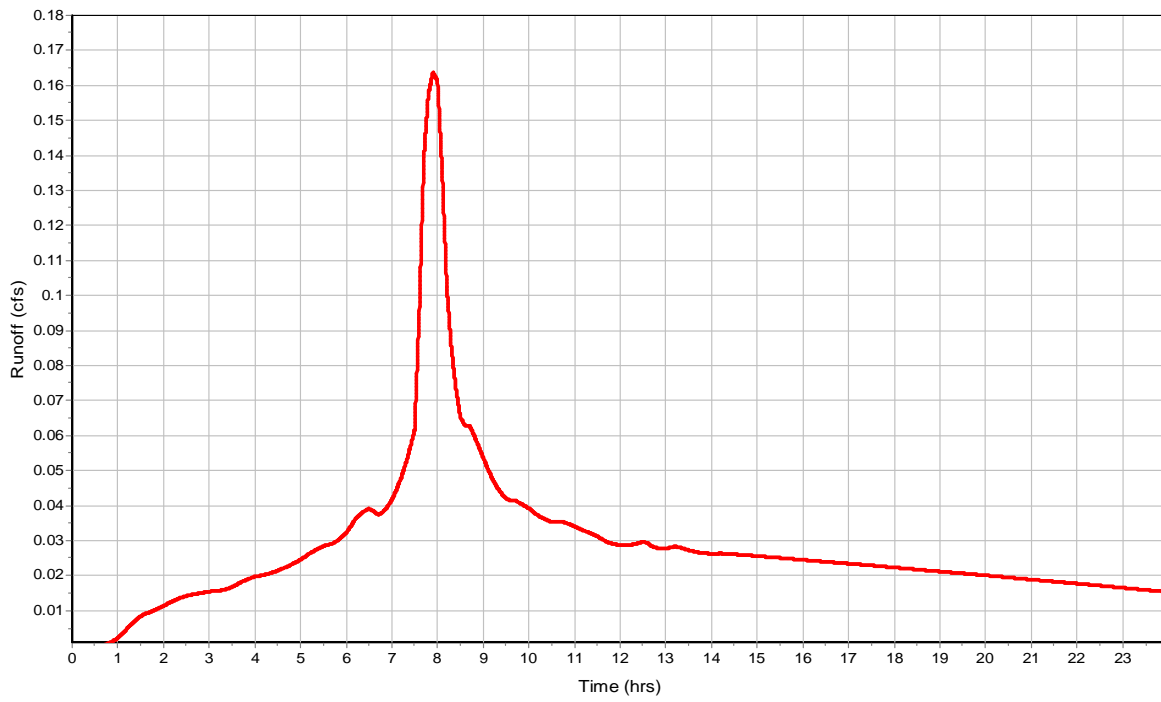

Subbasin : sdc9

Input Data

Area (ac) 0.09
Impervious Area (%) 70
Impervious Area Curve Number 98
Pervious Area Curve Number 76
Rain Gage ID Rain Gage-01

Composite Curve Number

Soil/Surface Description	32	Area (acres)	Soil Group	Curve Number
Composite Area & Weighted CN		0.09		91.4

Time of Concentration

Subbasin Runoff Results

Total Rainfall (in) 3.49
Total Runoff (in) 2.69
Peak Runoff (cfs) 0.06
Weighted Curve Number 91.4
Time of Concentration (days hh:mm:ss) 0 00:00:00

Subbasin : sdc9

Rainfall Intensity Graph

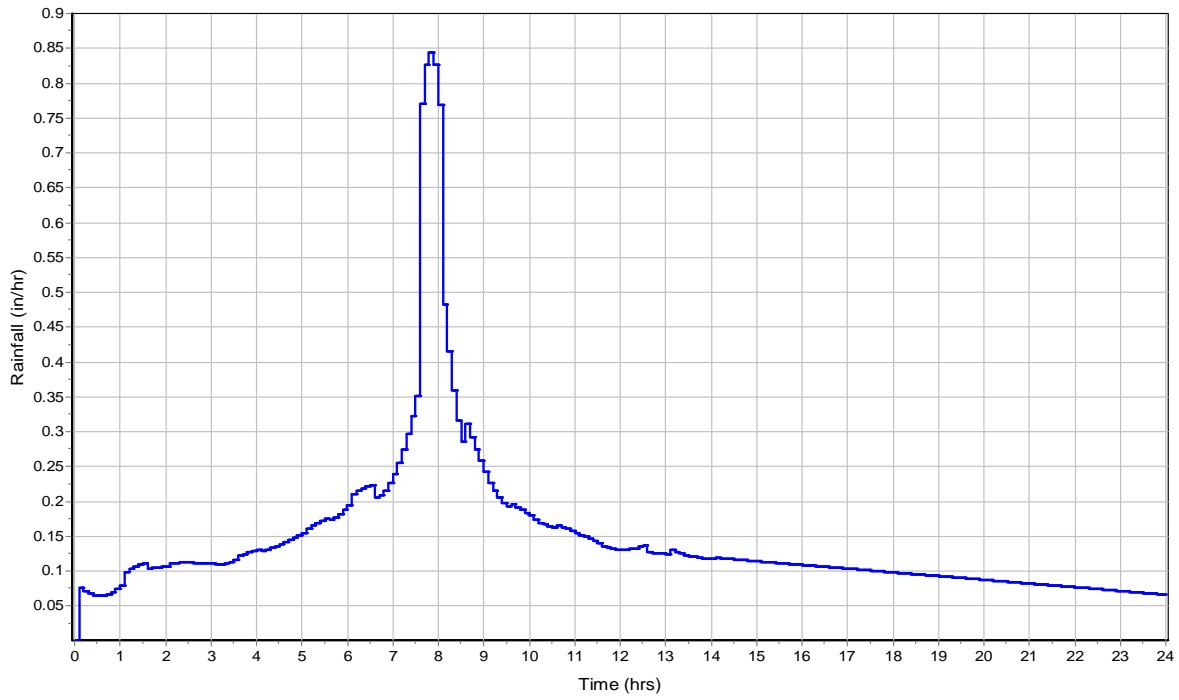

Runoff Hydrograph

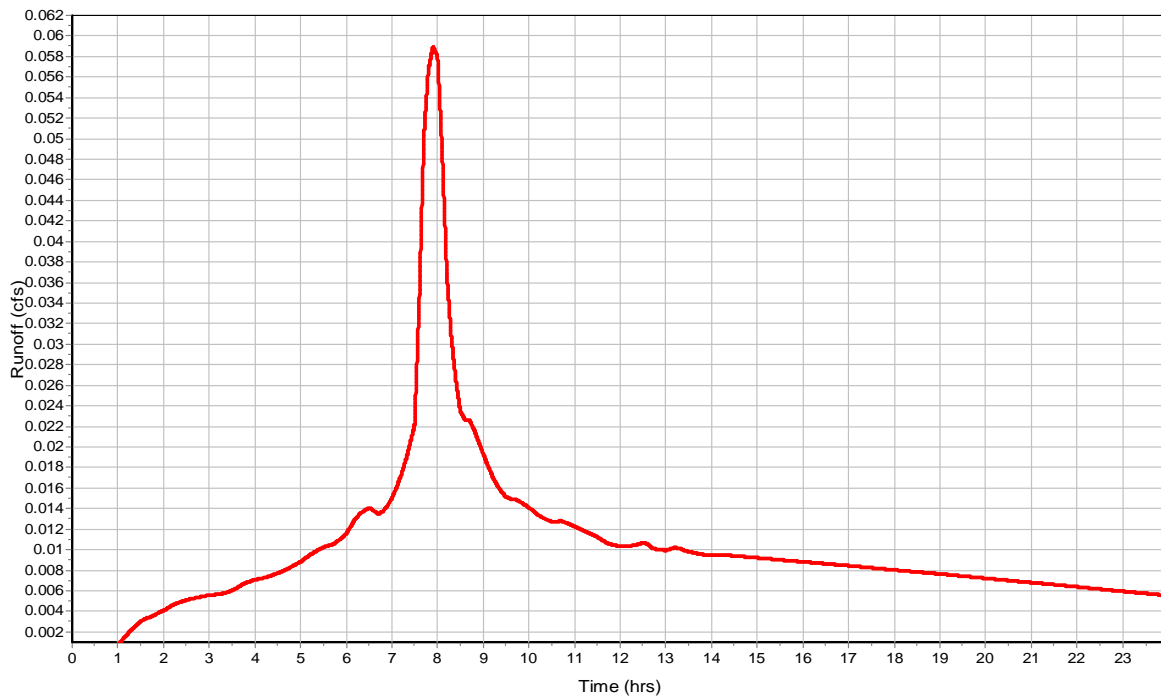

Subbasin : stcb500

Input Data

Area (ac) 0.23
Impervious Area (%) 70
Impervious Area Curve Number 98
Pervious Area Curve Number 76
Rain Gage ID Rain Gage-01

Composite Curve Number

Soil/Surface Description	32	Area (acres)	Soil Group	Curve Number
Composite Area & Weighted CN		0.23		91.4

Time of Concentration

Subbasin Runoff Results

Total Rainfall (in) 3.49
Total Runoff (in) 2.69
Peak Runoff (cfs) 0.15
Weighted Curve Number 91.4
Time of Concentration (days hh:mm:ss) 0 00:00:00

Subbasin : stcb500

Rainfall Intensity Graph

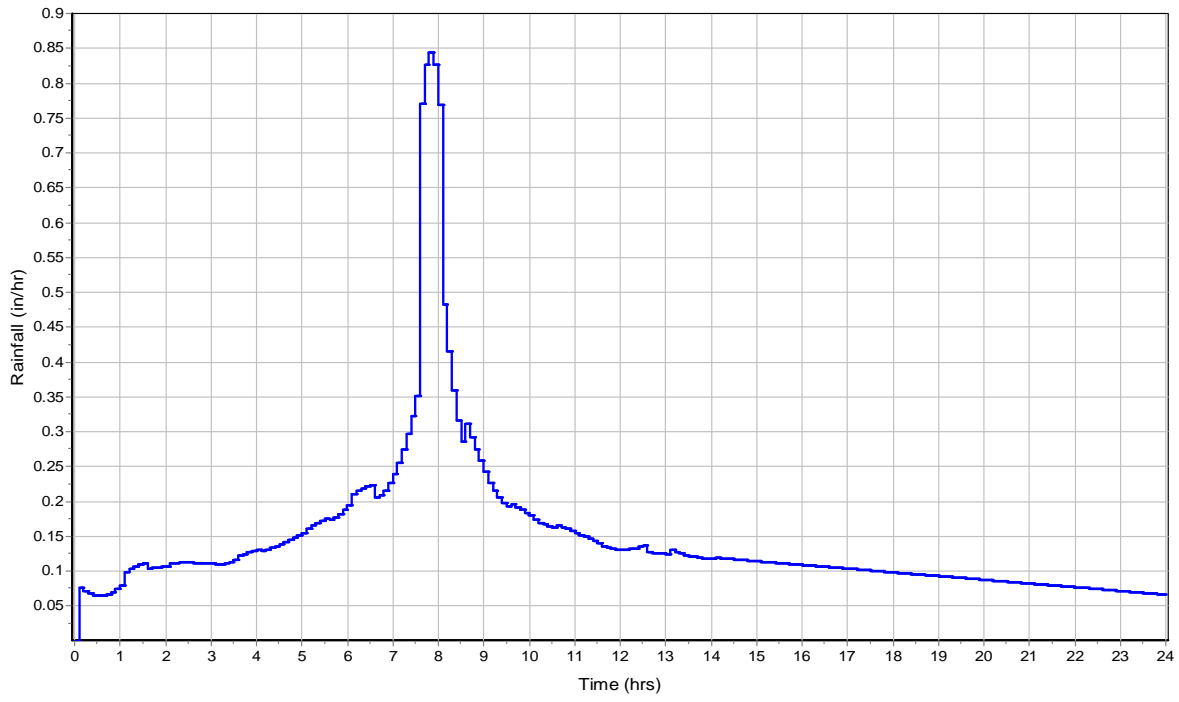

Runoff Hydrograph

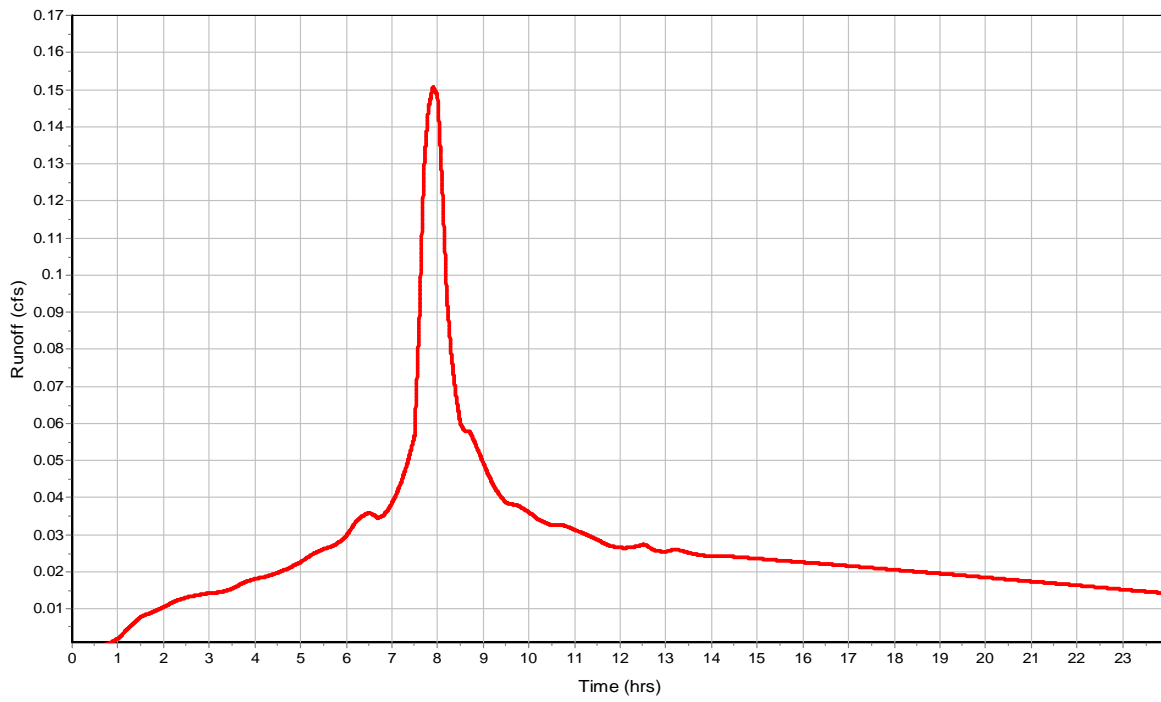

Subbasin : stcb501

Input Data

Area (ac) 0.28
Impervious Area (%) 70
Impervious Area Curve Number 98
Pervious Area Curve Number 76
Rain Gage ID Rain Gage-01

Composite Curve Number

Soil/Surface Description	32	Area (acres)	Soil Group	Curve Number
Composite Area & Weighted CN		0.28		91.4

Time of Concentration

Subbasin Runoff Results

Total Rainfall (in) 3.49
Total Runoff (in) 2.69
Peak Runoff (cfs) 0.18
Weighted Curve Number 91.4
Time of Concentration (days hh:mm:ss) 0 00:00:00

Subbasin : stcb501

Rainfall Intensity Graph

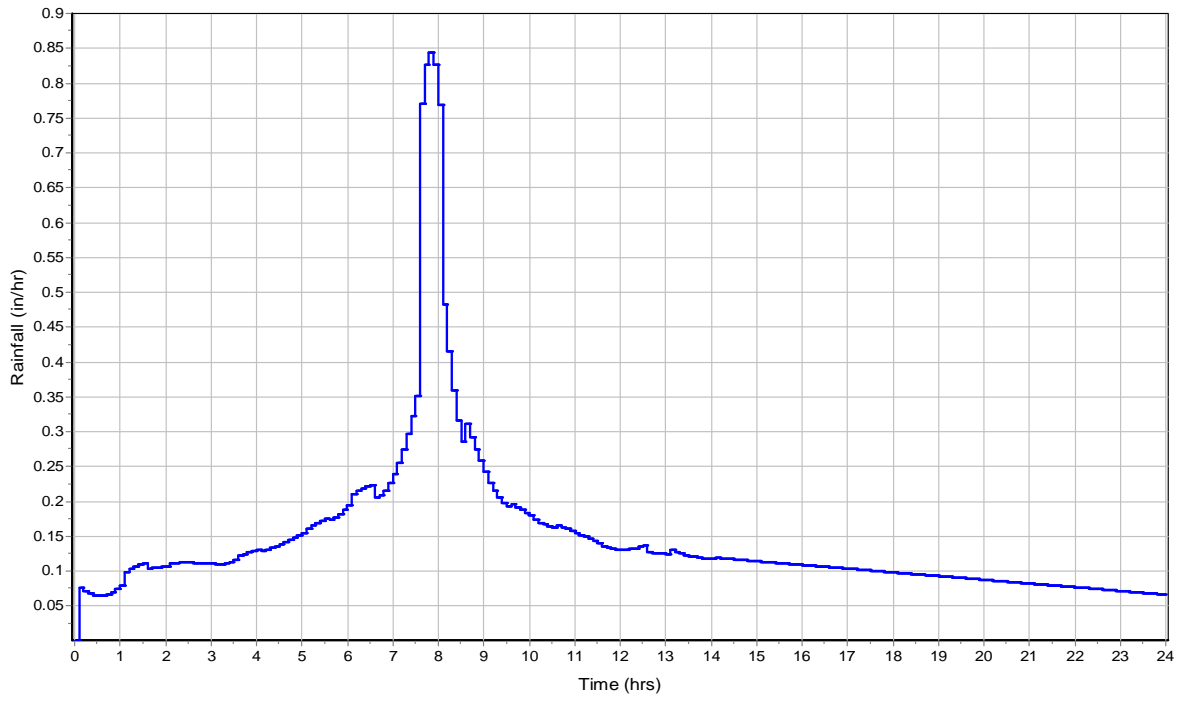

Runoff Hydrograph

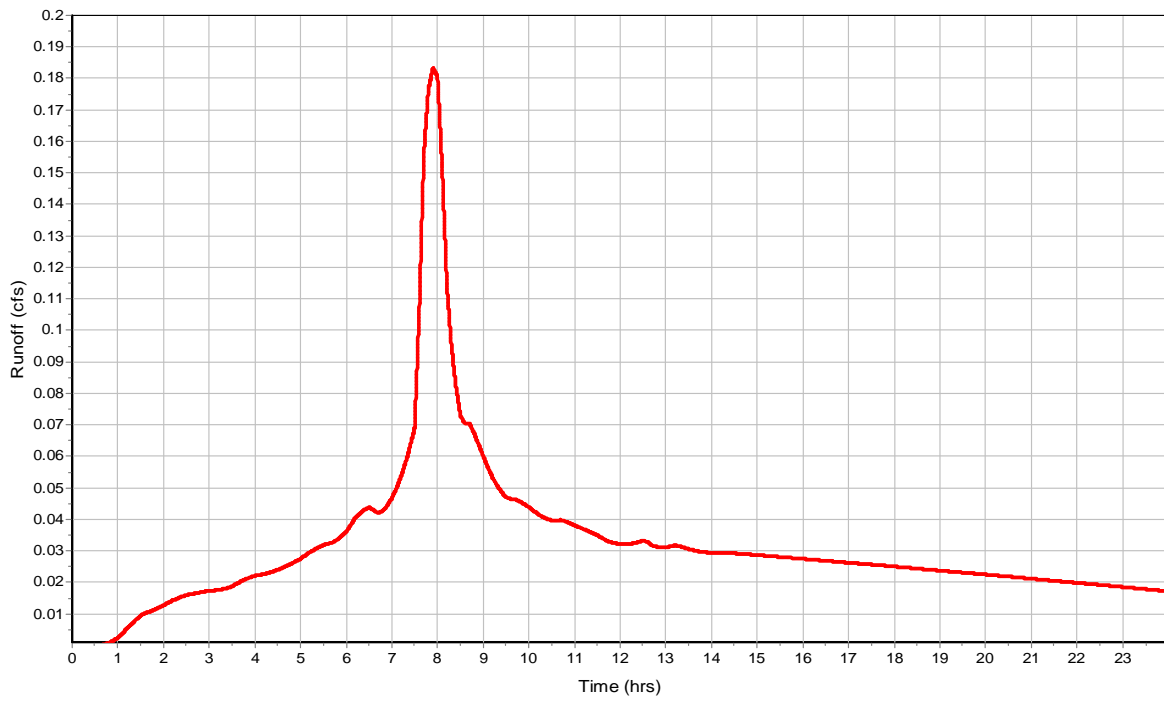

Subbasin : stcb502

Input Data

Area (ac) 0.38
Impervious Area (%) 70
Impervious Area Curve Number 98
Pervious Area Curve Number 76
Rain Gage ID Rain Gage-01

Composite Curve Number

Soil/Surface Description	32	Area (acres)	Soil Group	Curve Number
Composite Area & Weighted CN		0.38		91.4

Time of Concentration

Subbasin Runoff Results

Total Rainfall (in) 3.49
Total Runoff (in) 2.69
Peak Runoff (cfs) 0.25
Weighted Curve Number 91.4
Time of Concentration (days hh:mm:ss) 0 00:00:00

Subbasin : stcb502

Rainfall Intensity Graph

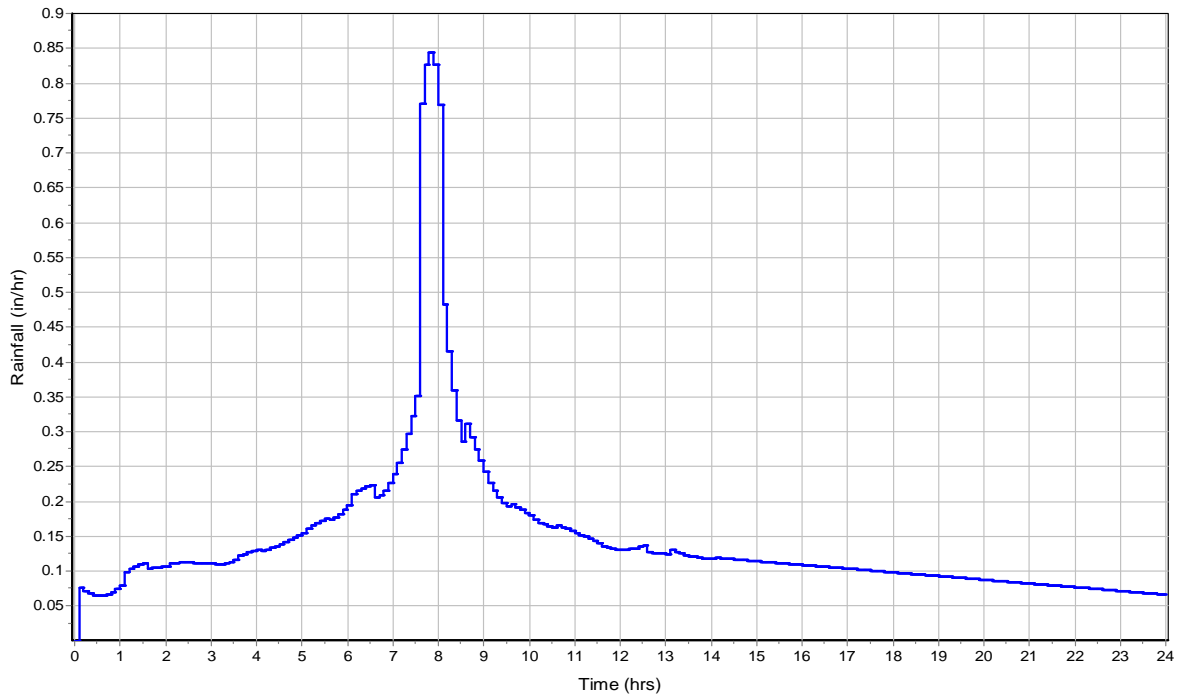

Runoff Hydrograph

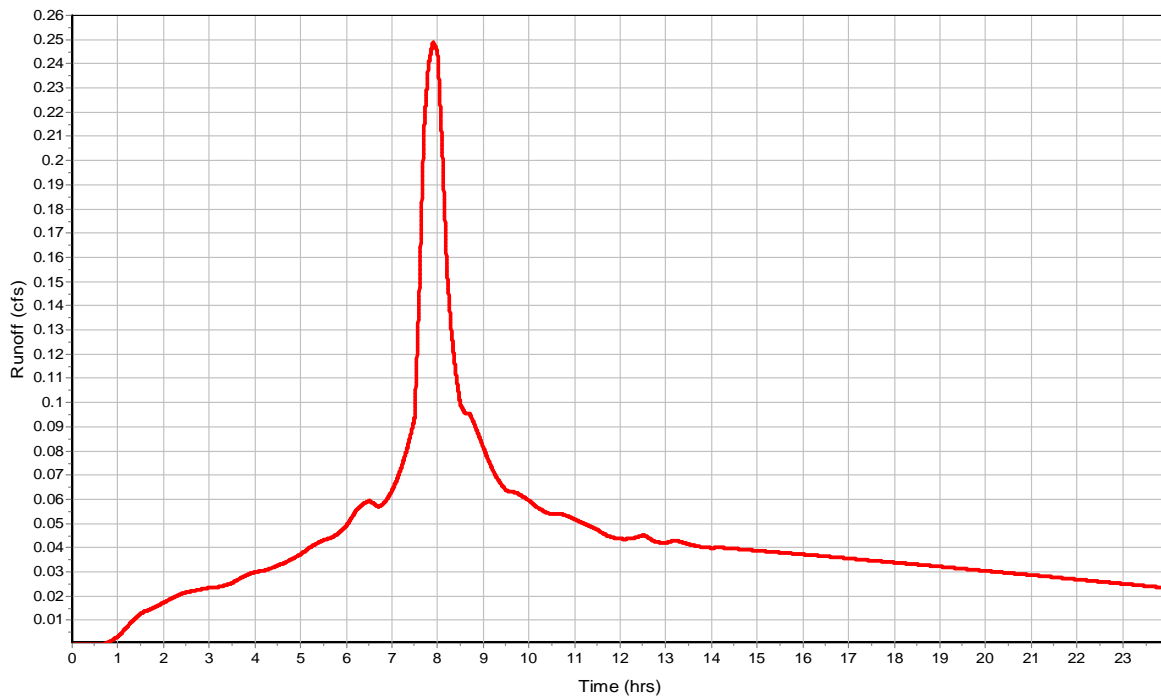

Subbasin : stcb505

Input Data

Area (ac) 0.3
Impervious Area (%) 70
Impervious Area Curve Number 98
Pervious Area Curve Number 76
Rain Gage ID Rain Gage-01

Composite Curve Number

Soil/Surface Description	32	Area (acres)	Soil Group	Curve Number
Composite Area & Weighted CN		0.3		91.4

Time of Concentration

Subbasin Runoff Results

Total Rainfall (in) 3.49
Total Runoff (in) 2.69
Peak Runoff (cfs) 0.2
Weighted Curve Number 91.4
Time of Concentration (days hh:mm:ss) 0 00:00:00

Subbasin : stcb505

Rainfall Intensity Graph

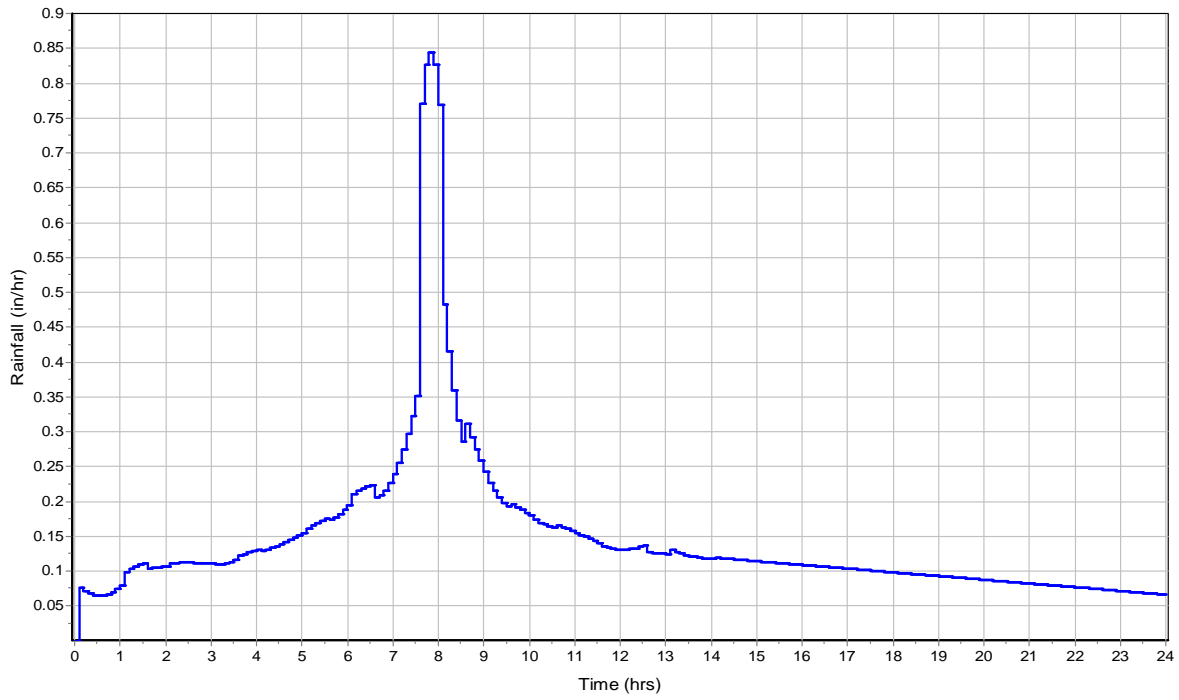

Runoff Hydrograph

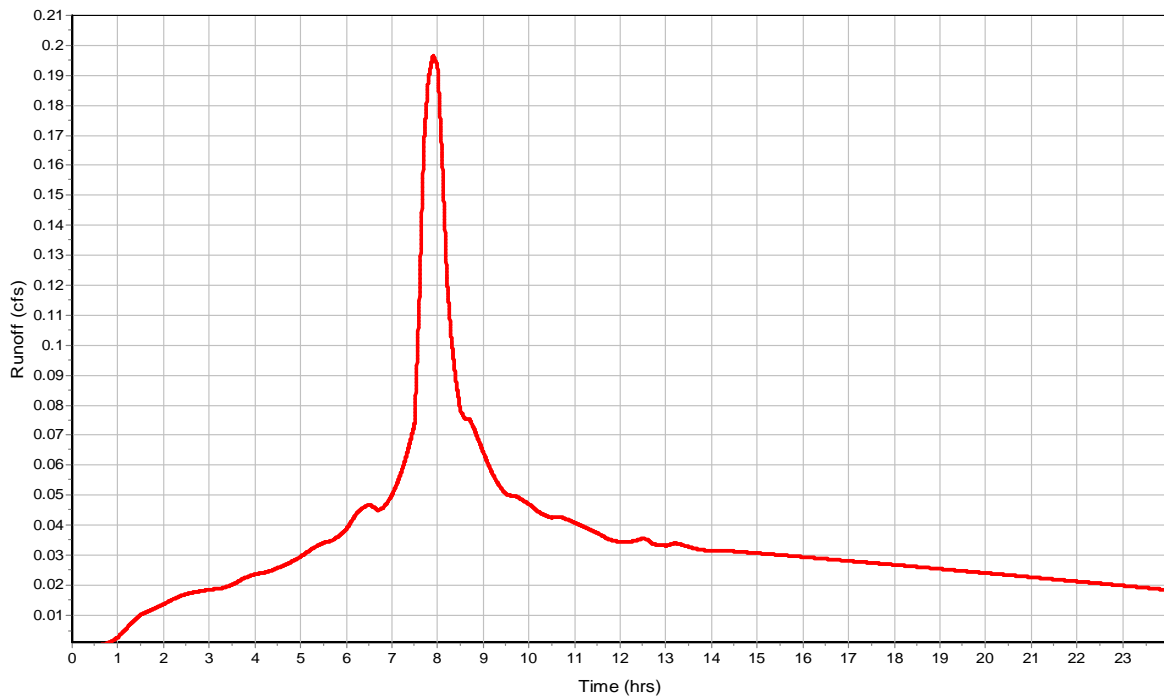

Subbasin : trench

Input Data

Area (ac) 0.25
Impervious Area (%) 25
Impervious Area Curve Number 98
Pervious Area Curve Number 76
Rain Gage ID Rain Gage-01

Composite Curve Number

Soil/Surface Description	32	Area (acres)	Soil Group	Curve Number
Composite Area & Weighted CN		0.25		81.5

Time of Concentration

Subbasin Runoff Results

Total Rainfall (in) 3.49
Total Runoff (in) 1.83
Peak Runoff (cfs) 0.1
Weighted Curve Number 81.5
Time of Concentration (days hh:mm:ss) 0 00:00:00

Subbasin : trench

Rainfall Intensity Graph

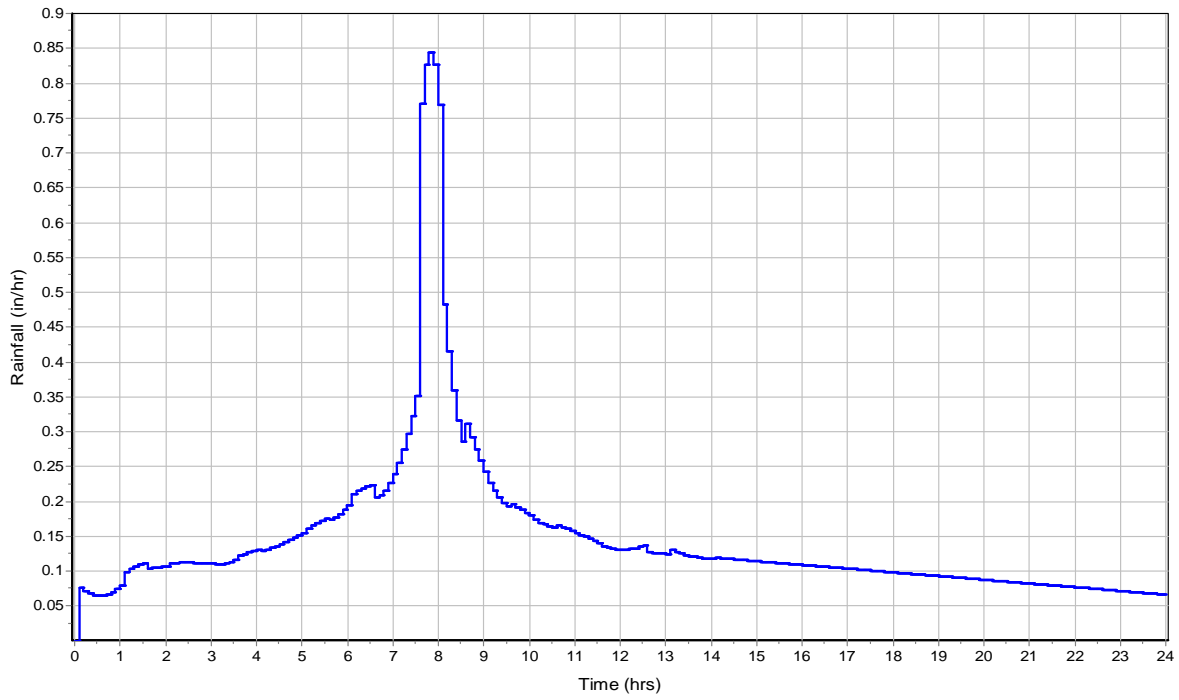

Runoff Hydrograph

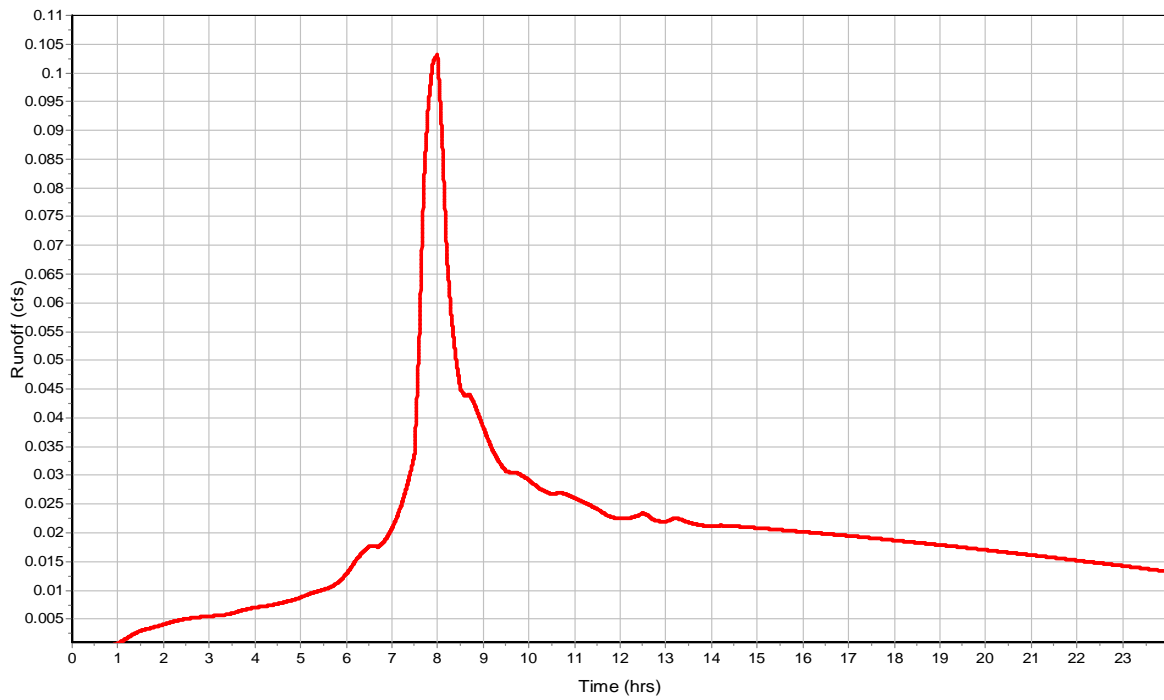

Junction Input

SN	Element ID	Invert Elevation (ft)	Ground/Rim (Max) Elevation (ft)	Ground/Rim (Max) Offset (ft)	Initial Water Elevation (ft)	Initial Water Depth (ft)	Surcharge Elevation (ft)	Surcharge Depth (ft)	Ponded Area (ft²)	Minimum Pipe Cover (in)
1	EX DRAIN OUTLET (STRM)	0.00	38.70	38.70	0.00	0.00	38.70	0.00	0.00	0.97
2	SDCB #1 (STRM)	33.31	41.90	8.59	33.31	0.00	41.90	0.00	0.00	80.63
3	SDCB #10 (STRM)	36.06	40.68	4.62	36.06	0.00	40.68	0.00	0.00	47.39
4	SDCB #3 (STRM)	35.36	38.42	3.06	35.36	0.00	38.42	0.00	0.00	24.72
5	SDCB #4 (STRM)	36.70	39.33	2.63	36.70	0.00	39.33	0.00	0.00	19.55
6	SDCB #5 (STRM)	37.72	41.53	3.81	37.72	0.00	41.53	0.00	0.00	33.73
7	SDCB #6 (STRM)	38.13	41.72	3.59	38.13	0.00	41.72	0.00	0.00	35.06
8	SDCB #8 (STRM)	33.98	39.00	5.02	33.98	0.00	39.00	0.00	0.00	25.79
9	SDCB #9 (STRM)	36.20	39.81	3.61	36.20	0.00	39.81	0.00	0.00	31.36
10	SDCO #11 (STRM)	36.59	41.79	5.19	36.59	0.00	41.79	0.00	0.00	54.31
11	SDCO #2 (STRM)	35.06	39.49	4.43	35.06	0.00	39.49	0.00	0.00	41.12
12	SDCO #7 (STRM)	33.72	40.04	6.32	33.72	0.00	40.04	0.00	0.00	63.80
13	STCB 500 (STRM)	38.06	41.41	3.35	38.06	0.00	41.41	0.00	0.00	32.24
14	STCB 501 (STRM)	37.52	41.50	3.98	37.52	0.00	41.50	0.00	0.00	37.01
15	STCB 502 (STRM)	36.95	41.09	4.14	36.95	0.00	41.09	0.00	0.00	41.62
16	STCB 505 (STRM)	38.43	41.38	2.95	38.43	0.00	41.38	0.00	0.00	27.43
17	STMH 2263 (STRM)	31.04	41.03	9.99	31.04	0.00	41.03	0.00	0.00	101.84
18	STMH 503 (STRM)	35.54	43.59	8.05	35.54	0.00	43.59	0.00	0.00	87.95
19	STMH 504 (STRM)	35.83	41.98	6.15	35.83	0.00	41.98	0.00	0.00	65.84
20	STMH 580 (STRM)	35.12	43.27	8.15	35.12	0.00	43.27	0.00	0.00	89.24
21	STMH 998 (STRM)	34.14	39.96	5.82	34.14	0.00	39.96	0.00	0.00	61.79
22	WQ OUTLET (STRM)	31.15	41.91	10.76	31.15	0.00	32.25	-9.66	0.00	85.56

Junction Results

SN	Element ID	Peak Inflow	Peak Lateral Inflow	Max HGL Elevation Attained	Max HGL Depth Attained	Max Surcharge Depth Attained	Min Freeboard Attained	Average HGL Elevation Attained	Average HGL Depth Attained	Time of Max HGL Occurrence	Time of Peak Flooding Occurrence	Total Flooded Volume	Total Time Flooded
		(cfs)	(cfs)	(ft)	(ft)	(ft)	(ft)	(ft)	(ft)	(days hh:mm)	(days hh:mm)	(ac-in)	(min)
1	EX DRAIN OUTLET (STRM)	0.10	0.10	38.00	38.00	0.00	0.70	30.33	30.33	0 08:26	0 00:00	0.00	0.00
2	SDCB #1 (STRM)	2.82	0.00	34.14	0.83	0.00	7.76	33.67	0.36	0 07:57	0 00:00	0.00	0.00
3	SDCB #10 (STRM)	0.34	0.34	36.49	0.43	0.00	4.18	36.23	0.17	0 07:54	0 00:00	0.00	0.00
4	SDCB #3 (STRM)	1.08	0.23	35.84	0.48	0.00	2.58	35.56	0.20	0 07:56	0 00:00	0.00	0.00
5	SDCB #4 (STRM)	0.85	0.16	37.05	0.35	0.00	2.27	36.86	0.16	0 07:55	0 00:00	0.00	0.00
6	SDCB #5 (STRM)	0.69	0.13	38.05	0.33	0.00	3.48	37.87	0.15	0 07:55	0 00:00	0.00	0.00
7	SDCB #6 (STRM)	0.36	0.36	38.42	0.29	0.00	3.30	38.26	0.13	0 07:54	0 00:00	0.00	0.00
8	SDCB #8 (STRM)	1.14	0.16	34.54	0.56	0.00	4.46	34.21	0.23	0 07:57	0 00:00	0.00	0.00
9	SDCB #9 (STRM)	0.64	0.06	36.54	0.34	0.00	3.27	36.36	0.16	0 07:56	0 00:00	0.00	0.00
10	SDCO #11 (STRM)	0.00	0.00	36.59	0.00	0.00	5.19	36.59	0.00	0 00:00	0 00:00	0.00	0.00
11	SDCO #2 (STRM)	1.38	0.30	35.57	0.51	0.00	3.92	35.28	0.22	0 07:56	0 00:00	0.00	0.00
12	SDCO #7 (STRM)	1.44	0.30	34.35	0.63	0.00	5.69	33.97	0.25	0 07:57	0 00:00	0.00	0.00
13	STCB 500 (STRM)	0.15	0.15	38.31	0.25	0.00	3.11	38.18	0.12	0 07:55	0 00:00	0.00	0.00
14	STCB 501 (STRM)	0.33	0.18	37.84	0.32	0.00	3.66	37.66	0.14	0 07:55	0 00:00	0.00	0.00
15	STCB 502 (STRM)	0.58	0.25	37.33	0.38	0.00	3.76	37.11	0.16	0 07:56	0 00:00	0.00	0.00
16	STCB 505 (STRM)	0.20	0.20	38.69	0.26	0.00	2.70	38.55	0.12	0 07:55	0 00:00	0.00	0.00
17	STMH 2263 (STRM)	2.81	0.00	31.56	0.52	0.00	9.47	31.25	0.21	0 07:57	0 00:00	0.00	0.00
18	STMH 503 (STRM)	0.34	0.00	35.90	0.36	0.00	7.69	35.70	0.16	0 07:56	0 00:00	0.00	0.00
19	STMH 504 (STRM)	0.34	0.00	36.19	0.36	0.00	5.79	35.99	0.16	0 07:55	0 00:00	0.00	0.00
20	STMH 580 (STRM)	0.34	0.00	35.41	0.29	0.00	7.87	35.25	0.13	0 07:57	0 00:00	0.00	0.00
21	STMH 998 (STRM)	0.34	0.00	34.58	0.44	0.00	5.37	34.28	0.14	0 07:57	0 00:00	0.00	0.00
22	WQ OUTLET (STRM)	2.81	0.00	31.87	0.72	0.00	10.04	31.47	0.32	0 07:57	0 00:00	0.00	0.00

Pipe Input

SN Element ID	Length (ft)	Inlet Invert Elevation (ft)	Inlet Invert Offset (ft)	Outlet Invert Elevation (ft)	Outlet Invert Offset (ft)	Total Drop (ft)	Average Slope (%)	Pipe Shape	Pipe Diameter or Height (in)	Pipe Width (in)	Manning's Roughness	Entrance Losses	Exit/Bend Losses	Additional Losses	Initial Flow Gate	Flap Gate
1 {STRM}.EX PIPE 1 (STRM)	17.41	31.04	0.00	30.40	0.00	0.64	3.6800	CIRCULAR	18.000	18.000	0.0130	0.5000	0.5000	0.0000	0.00	No
2 {STRM}.EX PIPE 2 (STRM)	187.64	34.14	0.00	35.12	0.00	-0.98	-0.5200	CIRCULAR	8.040	8.040	0.0130	0.5000	0.5000	0.0000	0.00	No
3 {STRM}.EX PIPE 3 (STRM)	114.10	35.17	0.05	35.54	0.00	-0.37	-0.3200	CIRCULAR	8.040	8.040	0.0130	0.5000	0.5000	0.0000	0.00	No
4 {STRM}.EX PIPE 4 (STRM)	78.85	35.59	0.05	35.83	0.00	-0.24	-0.3000	CIRCULAR	8.040	8.040	0.0130	0.5000	0.5000	0.0000	0.00	No
5 {STRM}.EX PIPE 5 (STRM)	46.30	35.88	0.05	36.06	0.00	-0.18	-0.3900	CIRCULAR	6.000	6.000	0.0130	0.5000	0.5000	0.0000	0.00	No
6 {STRM}.EX PIPE 6 (STRM)	165.77	36.95	0.00	37.52	0.00	-0.57	-0.3400	CIRCULAR	8.040	8.040	0.0130	0.5000	0.5000	0.0000	0.00	No
7 {STRM}.EX PIPE 7 (STRM)	116.66	37.75	0.23	38.06	0.00	-0.31	-0.2700	CIRCULAR	8.040	8.040	0.0130	0.5000	0.5000	0.0000	0.00	No
8 {STRM}.EX PIPE 8 (STRM)	262.01	38.43	0.00	37.72	0.00	0.71	0.2700	CIRCULAR	8.040	8.040	0.0130	0.5000	0.5000	0.0000	0.00	No
9 {STRM}.PIPE 1 (STRM)	21.85	31.15	0.00	31.04	0.00	0.11	0.5000	CIRCULAR	18.000	18.000	0.0130	0.5000	0.5000	0.0000	0.00	No
10 {STRM}.PIPE 10 (STRM)	51.37	33.98	0.00	33.72	0.00	0.26	0.5000	CIRCULAR	12.000	12.000	0.0130	0.5000	0.5000	0.0000	0.00	No
11 {STRM}.PIPE 11 (STRM)	31.66	33.98	0.00	34.14	0.00	-0.16	-0.5000	CIRCULAR	8.040	8.040	0.0130	0.5000	0.5000	0.0000	0.00	No
12 {STRM}.PIPE 12 (STRM)	46.98	36.20	0.00	35.85	1.87	0.35	0.7500	CIRCULAR	12.000	12.000	0.0130	0.5000	0.5000	0.0000	0.00	No
13 {STRM}.PIPE 13 (STRM)	15.80	37.95	37.95	36.20	0.00	1.75	11.0800	CIRCULAR	8.040	8.040	0.0130	0.5000	0.5000	0.0000	0.00	No
14 {STRM}.PIPE 14 (STRM)	99.83	36.95	0.00	36.20	0.00	0.75	0.7500	CIRCULAR	8.040	8.040	0.0130	0.5000	0.5000	0.0000	0.00	No
15 {STRM}.PIPE 15 (STRM)	71.16	36.59	0.00	36.06	0.00	0.53	0.7500	CIRCULAR	8.040	8.040	0.0130	0.5000	0.5000	0.0000	0.00	No
16 {STRM}.PIPE 2 (STRM)	6.13	33.31	0.00	33.28	2.13	0.03	0.4900	CIRCULAR	18.000	18.000	0.0130	0.5000	0.5000	0.0000	0.00	No
17 {STRM}.PIPE 4 (STRM)	118.14	35.06	0.00	34.18	0.87	0.88	0.7500	CIRCULAR	12.000	12.000	0.0130	0.5000	0.5000	0.0000	0.00	No
18 {STRM}.PIPE 5 (STRM)	39.70	35.36	0.00	35.06	0.00	0.30	0.7500	CIRCULAR	12.000	12.000	0.0130	0.5000	0.5000	0.0000	0.00	No
19 {STRM}.PIPE 6 (STRM)	170.58	36.70	0.00	35.36	0.00	1.34	0.7900	CIRCULAR	12.000	12.000	0.0130	0.5000	0.5000	0.0000	0.00	No
20 {STRM}.PIPE 7 (STRM)	136.20	36.70	0.00	37.72	0.00	-1.02	-0.7500	CIRCULAR	12.000	12.000	0.0130	0.5000	0.5000	0.0000	0.00	No
21 {STRM}.PIPE 8 (STRM)	55.28	38.13	0.00	37.72	0.00	0.41	0.7500	CIRCULAR	8.040	8.040	0.0130	0.5000	0.5000	0.0000	0.00	No
22 {STRM}.PIPE 9 (STRM)	82.45	33.72	0.00	33.31	0.00	0.41	0.5000	CIRCULAR	12.000	12.000	0.0130	0.5000	0.5000	0.0000	0.00	No

Pipe Results

SN Element ID	Peak Flow (cfs)	Time of Peak Flow Occurrence (days hh:mm)	Design Flow Capacity (cfs)	Peak Flow/Design Flow Ratio	Peak Flow Velocity (ft/sec)	Travel Time (min)	Peak Flow Depth (ft)	Peak Flow Depth/Total Depth Ratio	Total Time Surcharged (min)	Froude Number	Reported Condition
1 {STRM}.EX PIPE 1 (STRM)	2.81	0 07:57	20.14	0.14	6.37	0.05	0.45	0.30	0.00		Calculated
2 {STRM}.EX PIPE 2 (STRM)	0.34	0 07:57	0.87	0.38	1.75	1.79	0.36	0.55	0.00		Calculated
3 {STRM}.EX PIPE 3 (STRM)	0.34	0 07:56	0.69	0.49	2.08	0.91	0.31	0.47	0.00		Calculated
4 {STRM}.EX PIPE 4 (STRM)	0.34	0 07:55	0.67	0.50	1.90	0.69	0.34	0.51	0.00		Calculated
5 {STRM}.EX PIPE 5 (STRM)	0.34	0 07:54	0.35	0.96	2.14	0.36	0.37	0.75	0.00		Calculated
6 {STRM}.EX PIPE 6 (STRM)	0.33	0 07:55	0.71	0.47	1.80	1.53	0.35	0.52	0.00		Calculated
7 {STRM}.EX PIPE 7 (STRM)	0.15	0 07:55	0.62	0.24	1.58	1.23	0.21	0.32	0.00		Calculated
8 {STRM}.EX PIPE 8 (STRM)	0.20	0 07:55	0.63	0.31	1.32	3.31	0.29	0.44	0.00		Calculated
9 {STRM}.PIPE 1 (STRM)	2.81	0 07:57	7.45	0.38	4.11	0.09	0.62	0.41	0.00		Calculated
10 {STRM}.PIPE 10 (STRM)	1.14	0 07:57	2.52	0.45	2.35	0.36	0.59	0.59	0.00		Calculated
11 {STRM}.PIPE 11 (STRM)	0.34	0 08:02	0.85	0.39	1.25	0.42	0.50	0.75	0.00		Calculated
12 {STRM}.PIPE 12 (STRM)	0.64	0 07:56	3.08	0.21	2.89	0.27	0.32	0.32	0.00		Calculated
13 {STRM}.PIPE 13 (STRM)	0.05	0 08:26	4.03	0.01	0.88	0.30	0.17	0.25	0.00		Calculated
14 {STRM}.PIPE 14 (STRM)	0.58	0 07:56	1.05	0.55	2.96	0.56	0.37	0.55	0.00		Calculated
15 {STRM}.PIPE 15 (STRM)	0.00	0 00:00	1.05	0.00	0.00		0.22	0.33	0.00		Calculated
16 {STRM}.PIPE 2 (STRM)	2.81	0 07:57	7.35	0.38	3.28	0.03	0.73	0.49	0.00		Calculated
17 {STRM}.PIPE 4 (STRM)	1.38	0 07:56	3.08	0.45	3.64	0.54	0.49	0.49	0.00		Calculated
18 {STRM}.PIPE 5 (STRM)	1.08	0 07:56	3.08	0.35	2.80	0.24	0.49	0.49	0.00		Calculated
19 {STRM}.PIPE 6 (STRM)	0.85	0 07:55	3.16	0.27	2.72	1.05	0.42	0.42	0.00		Calculated
20 {STRM}.PIPE 7 (STRM)	0.69	0 07:55	3.09	0.22	2.88	0.79	0.34	0.34	0.00		Calculated
21 {STRM}.PIPE 8 (STRM)	0.36	0 07:54	1.05	0.35	2.30	0.40	0.31	0.46	0.00		Calculated
22 {STRM}.PIPE 9 (STRM)	1.44	0 07:57	2.52	0.57	2.34	0.59	0.73	0.73	0.00		Calculated

Appendix E

CSWPPP



Construction Stormwater Pollution Prevention Plan

PREPARED FOR:

AWB Engineers
1942 Northwood Drive
Salisbury, MD 21801

PROJECT:

CPFD Puyallup
322 Valley Ave NW
Puyallup, WA 98371
2230491.11

PREPARED BY:

Zachary Perdue, EIT
Project Engineer

REVIEWED BY:

Todd C. Sawin, PE, DBIA, LEED AP
Principal

DATE:

February 2024

Construction Stormwater Pollution Prevention Plan

PREPARED FOR:

AWB Engineers
1942 Northwood Drive
Salisbury, MD 21801

PROJECT:

CPFD Puyallup
322 Valley Ave NW
Puyallup, WA 98371
2230491.11

PREPARED BY:

Zachary Perdue, EIT
Project Engineer

REVIEWED BY:

Todd C. Sawin, PE, DBIA, LEED AP
Principal

DATE:

February 2024

I hereby state that this [Construction Stormwater Pollution Prevention Plan](#) for the [CPFD](#) project has been prepared by me or under my supervision and meets the standard of care and expertise that is usual and customary in this community for professional engineers. I understand that [the City of Puyallup](#) does not and will not assume liability for the sufficiency, suitability, or performance of drainage facilities prepared by me.

Table of Contents

Section	Page
1.0 Introduction	1
2.0 Project Description	2
3.0 Existing Site Conditions	2
4.0 Adjacent Areas and Drainage	2
5.0 Critical Areas	2
6.0 Soils	3
7.0 Potential Erosion Problems	3
8.0 Construction Stormwater Pollution Prevention Elements	3
8.1 Mark Clearing Limits	3
8.2 Establish Construction Access.....	3
8.3 Control Flow Rates.....	3
8.4 Install Sediment Controls	4
8.5 Stabilize Soils and Dust Control.....	4
8.6 Protect Slopes.....	4
8.7 Protect Drain Inlets.....	4
8.8 Stabilize Channels and Outlets.....	4
8.9 Control Pollutants.....	4
8.9.1 Required BMPs	5
8.10 Control Dewatering	6
8.11 Maintain BMPs.....	6
8.12 Manage the Project.....	7
9.0 Construction Sequence and Phasing	7
9.1 Construction Sequence.....	7
9.2 Construction Phasing.....	8
10.0 Construction Schedule	8
11.0 Financial/Ownership Responsibilities	8
12.0 Certified Erosion and Sediment Control Lead (CESCL)	9
13.0 Monitoring and Sampling Requirements	10



13.1	Site Inspection.....	10
13.2	Stormwater Quality Sampling	10
13.2.1	Turbidity Sampling	10
13.2.2	pH Sampling.....	11
14.0	Conclusion.....	11

Exhibits

Appendix F

- F-1 TESC Plan
- F-2 TESC Notes and Details
- F-3 TESC Pond Calculations

Appendix G

Inspection Logs

Appendix H

Best Management Practices (BMPs)

- BMP C101 Preserving Natural Vegetation
- BMP C103 High Visibility Fence
- BMP C105 Stabilized Construction Entrance
- BMP C107 Construction Road / Parking Area Stabilization
- BMP C120 Temporary and Permanent Seeding
- BMP C121 Mulching
- BMP C122 Nets and Blankets
- BMP C123 Plastic Covering
- BMP C140 Dust Control
- BMP C150 Materials on Hand
- BMP C151 Concrete Handling
- BMP C152 Sawcutting and Surface Pollution Prevention
- BMP C153 Material Delivery, Storage, and Containment
- BMP C160 Certified Erosion and Sediment Control Lead
- BMP C103 Interceptor Swale
- BMP C207 Check Dams
- BMP C220 Storm Drain Inlet Protection
- BMP C233 Silt Fence
- BMP C240 Sediment Trap

1.0 Introduction

In 1972, Congress passed the Federal Water Pollution Control Act (FWPCA), also known as the Clean Water Act (CWA), to restore and maintain the quality of the nation's waterways. The ultimate goal was to make sure that rivers and streams were fishable, swimmable, and drinkable. In 1987, the Water Quality Act (WQA) added provisions to the CWA that allowed the Environmental Protection Agency to govern stormwater discharges from construction sites. The National Pollutant Discharge Elimination System (NPDES) General Permit includes provisions for development of a Stormwater Pollution Prevention Plan (SWPPP) to maximize the potential benefits of pollution prevention and sediment and erosion control measures at construction sites.

The proposed project will disturb more than 1 acre of area, and therefore is required to obtain an NPDES General Permit for Stormwater Associated with Construction Activities.

The 2019 Department of Ecology (DOE) *Stormwater Management Manual for Western Washington (SMMWW)* requires a Construction SWPPP for projects that add or replace more than 2,000 square feet of impervious surfaces. The proposed project will exceed this threshold; therefore, a Construction SWPPP is required.

Development, implementation, and maintenance of the Construction SWPPP will provide the selected General Contractor with the framework for reducing soil erosion and minimizing pollutants in stormwater during construction of the proposed project. The Construction SWPPP will:

- Define the characteristics of the site and the type of construction that will occur.
- Describe the practices that will be implemented to control erosion and the release of pollutants in stormwater.
- Create an implementation schedule to ensure that the practices described in this Construction SWPPP are in fact implemented, and to evaluate the plan's effectiveness in reducing erosion, sediment, and pollutant levels in stormwater discharged from the site.
- Describe the final stabilization/termination design to minimize erosion and prevent stormwater impacts after construction is complete.

This Construction SWPPP:

- Identifies the SWPPP Coordinator with a description of this person's duties.
- Identifies the Stormwater Pollution Prevention Team (SWPP Team) that will assist in implementation of the Construction SWPPP during construction.
- Describes the existing site conditions, including existing land use for the site, the soil types at the site, as well as the location of surface waters that are located on or next to the site.
- Identifies the body or bodies of water that will receive runoff from the construction site, including the ultimate body of water that receives the stormwater.
- Identifies the drainage areas and potential stormwater contaminants.
- Describes the stormwater management controls and various Best Management Practices (BMPs) necessary to reduce erosion, sediment, and pollutants in stormwater discharge.
- Describes the facility monitoring plan and how controls will be coordinated with construction activities.
- Describes the implementation schedule and provisions for amendment of the plan.

2.0 Project Description

The Coastal Pacific Food Distribution (CPFD) project proposes to redevelop an approximately 5-acre site located on Tax Parcel 0420215019 in the City of Puyallup, Washington. Approximately 2.3 acres of the existing 5-acre site will be disturbed as a part of this project. Refer to Appendix A, Exhibit A-1 for the Vicinity Map.

The developed site includes 1 new building, new asphalt turnaround for trucks and emergency vehicles, and utilities. New catch basins will be added to accommodate flows from the new paved area. Runoff collected in these catch basins and existing catch basins onsite will be treated by an Oldcastle Biopod Biofilter underground vault. Stormwater ultimately discharges to the Puyallup River via existing storm drainage mains.

The proposal will follow the stormwater management design criteria outlined in the DOE 2019 *SMMWW*. Control methods during construction include working during the dry season, minimizing the amount of area that is disturbed at any given time, installing a stabilized construction entrance, placing inlet protection at catch basin, and utilizing silt fence, if necessary.

Refer to Appendix F, Exhibits F-1 and F-2 for the TESC Plan and TESC Notes and Details respectively.

3.0 Existing Site Conditions

The existing area is approximately 5 acres and is currently developed. Within the parcel, parking and driveway makes up 1.58 acres, nonpollution generating impervious surfaces such as roof and sidewalk make up 0.56 acres, and grass lawn covers 2.86 acres.

The site contains three bioretention ponds. Two of the ponds treat onsite stormwater runoff. The third pond treats upstream stormwater flows from the west and is located in the southwest corner of the site. The site is relatively flat except for within the bioretention ponds. A topographical survey of the project was prepared by AHBL that shows existing site conditions. See Appendix A, Exhibit A-2 for the Existing Conditions Map.

4.0 Adjacent Areas and Drainage

In existing conditions, the existing bioretention pond in the southwest corner of the site receives upstream stormwater flows from the west. This bioretention pond is to remain as is undisturbed throughout this redevelopment project. Existing commercial properties to the north and to the east of the site manage and maintain their stormwater flows and do not discharge to the site. To the south of the project site there is WSDOT SR167 ROW that is currently a gravel road. This existing gravel road does not discharge to the site. Valley Avenue E to the north contains its own stormwater collection and conveyance system which prevents discharge to the site.

Stormwater leaves the site to the south via the 36" drainage main that runs southeast. The drainage main then runs south through a 72" pipe. The pipe then outfalls to the Puyallup River south of N Levee Road. The Puyallup River is approximately 1,000 feet south of the site.

5.0 Critical Areas

There are no known critical areas on or near the project site.

6.0 Soils

The Natural Resources Conservation Service (NRCS) classifies the onsite soils as Puyallup fine sandy loam – 31A and Sultan silt loam – 42A. Appendix A, Exhibit A-4 provides the NRCS soil map. Puyallup fine sandy loam soils are classified as hydrologic soil Series A, which typically have low erosion and high infiltration potential. Sultan silt loam are classified as hydrologic soil Series C, which typically have moderate erosion and moderate infiltration potential.

In addition to the NRCS information, GeoEngineers prepared a geotechnical report for the site on January 5, 2024. The soils encountered onsite by GeoEngineers contained a significant percentage of fines. In their report they conclude that “the infiltration rate of the silt alluvium would be considered very low or practically infeasible”. Consequently, they do not recommend using infiltration as a solution for stormwater control.

See Appendix B for the Geotechnical Engineering Report.

7.0 Potential Erosion Problems

Based on an investigation by GeoEngineers, no known erosion problems exist on or near the project site.

Appropriate measures should be taken to stabilize soils for construction work before the wet season.

8.0 Construction Stormwater Pollution Prevention Elements

The purpose of this section is to describe how each of the 12 Construction Stormwater Pollution Prevention elements has been addressed and to identify the type and location of BMPs used to satisfy the required element. If an element is not applicable to the project, a reason is provided.

8.1 Mark Clearing Limits

Prior to beginning land-disturbing activities, clearing limits will be marked with high visibility plastic or metal fencing (BMP C103) as shown on the TESC Plan in Appendix F, Exhibit F-1. All vegetated areas outside the marked clearing limits shall be preserved in existing conditions (BMP C101). Fencing will also be used to protect the existing bioretention pond.

8.2 Establish Construction Access

A stabilized construction entrance (BMP C105) is proposed at the southwest corner of the site off the existing driveway. If sediment is transported onto the road surface, the road shall be cleaned by shoveling or sweeping prior to washing. Sediment removal by washing alone will not be allowed. If sediment is tracked from the site, the City of Puyallup may require stabilization of internal roads to contain the sediment or require the installation of wheel wash basins. Construction roads / parking areas (BMP C107) will be stabilized wherever they are used.

8.3 Control Flow Rates

Interceptor swales are to be used to direct flows. Silt fences are to be used around the perimeter of the clearing limits to keep sediment onsite. A temporary sediment trap will retain stormwater and sediment. Permanent flow control systems must be constructed and functioning prior to constructing hard surfaces.

8.4 Install Sediment Controls

As part of initial construction activities, BMPs will be installed to trap sediment onsite. Inlet Protection (BMP C220) for existing catch basins and proposed catch basins within the project area and in the adjacent streets that may receive runoff shall be implemented. Silt fence (BMP C233) will be placed along all downgradient boundaries of the proposed project limits to prevent sediment laden runoff from leaving the site. A temporary sediment trap (BMP C240) will also be used, of which sizing calculations are included in Appendix F, exhibit F-3.

8.5 Stabilize Soils and Dust Control

Exposed areas and soil stockpiles must be stabilized according to the following schedule:

1. From April 1 to October 31, all disturbed areas at final grade and all exposed areas that are scheduled to remain unworked for more than 30 days shall be stabilized within 10 days.
2. From November 1 to March 31, all exposed soils at final grade shall be stabilized immediately using permanent or temporary measures. Exposed soils with an area greater than 5,000 square feet that are scheduled to remain unworked for more than 24 hours, and exposed areas of less than 5,000 square feet that will remain unworked for more than 7 days shall be stabilized immediately.

All disturbed areas that are not planned to be constructed on within 90 days from time of clearing and grading shall be revegetated with the native vegetation.

To stabilize soils, BMPs such as temporary and permanent seeding (BMP C120), mulching (BMP C121), nets and blankets (BMP C122), and plastic coverings (BMP C123) will be utilized. While Dust will be controlled following BMP C140.

8.6 Protect Slopes

The majority of the site has flat slopes of 0-3%. There are small, isolated areas with slopes greater than 3%, however, no slopes over 20% are being disturbed. All exposed soil not covered by buildings, roadway, or sidewalks will be Hydroseeded, and their slopes will be no greater than 2:1.

8.7 Protect Drain Inlets

Storm drain inlets shall be protected so that surface water runoff does not enter the conveyance system without first being filtered. Inlets shall be inspected weekly, at a minimum, and daily during storm events. Storm Drain Inlet Protection (BMP C220) will be provided.

8.8 Stabilize Channels and Outlets

No channels or outlets exist on or near the project site.

8.9 Control Pollutants

All waste materials will be collected and stored in a securely closed metal dumpster. All trash and construction debris from the site will be deposited in the dumpster. The dumpster will be emptied a minimum of once per week, and the trash will be hauled to the local landfill. No construction materials will be buried onsite. All personnel will be instructed regarding the correct procedure for waste disposal. All sanitary waste will be collected from the portable units a minimum of three times per week. Good housekeeping and spill control practices will be followed during

construction to minimize stormwater contamination from petroleum products, fertilizers, and concrete.

Table 1 below lists several pollutants that are commonly found on construction sites that have the potential to contaminate storm runoff. These pollutants will be present, mainly in areas of building and pavement construction. The Contractor and the SWPPP/TESC Coordinator will be responsible for identifying areas where these pollutants are being used and monitor runoff coming from these areas. Pollutant sources will be covered with plastic if contaminated runoff is observed from these areas. If contaminated runoff is found in the sediment trap or soils, the Erosion Control Specialist will direct the Contractor to remove the polluted water/soil and dispose of it in an approved area offsite.

Table 1 – Potential Construction Site Stormwater Pollutants

Trade Name Material	Chemical/Physical Description ⁽¹⁾	Stormwater Pollutants ⁽¹⁾
Pesticides (insecticides, fungicides, herbicide, rodenticides)	Various colored to colorless liquid, powder, pellets, or grains	Chlorinated hydrocarbons, organophosphates, carbamates, arsenic
Fertilizer	Liquid or solid grains	Nitrogen, phosphorous
Plaster	White granules or powder	Calcium sulphate, calcium carbonate, sulfuric acid
Cleaning solvents	Colorless, blue, or yellow-green liquid	Perchloroethylene, methylene chloride, trichloroethylene, petroleum distillates
Asphalt	Black solid	Oil, petroleum distillates
Concrete	White solid	Limestone, sand
Glue, adhesives	White or yellow liquid	Polymers, epoxies
Paints	Various colored liquid	Metal oxides, Stoddard solvent, talc, calcium carbonate, arsenic
Curing compounds	Creamy white liquid	Naphtha
Wastewater from construction equipment washing	Water	Soil, oil & grease, solids
Wood preservatives	Clear amber or dark brown liquid	Stoddard solvent, petroleum distillates, arsenic, copper, chromium
Hydraulic oil/fluids	Brown oily petroleum hydrocarbon	Mineral oil
Gasoline	Colorless, pale brown or pink petroleum hydrocarbon	Benzene, ethyl benzene, toluene, xylene, MTBE
Diesel fuel	Clear, blue-green to yellow liquid	Petroleum distillate, oil & grease, naphthalene, xylenes
Kerosene	Pale yellow liquid petroleum hydrocarbon	Coal oil, petroleum distillates
Antifreeze/coolant	Clear green/yellow liquid	Ethylene glycol, propylene glycol, heavy metals (copper, lead, zinc)
Erosion	Solid Particles	Soil, Sediment

⁽¹⁾ Data obtained from MSDS when available

8.9.1 Required BMPs

The following BMPs or equivalent measures are required of all businesses and agencies during concrete pouring and asphalt application at temporary sites:

- Employees must be educated on the pollution hazards of concrete and asphalt application and cutting.

- Loose aggregate chunks and dust must be swept or shoveled and collected (not hosed down a storm drain) for recycling or proper disposal at the end of each workday, especially at work sites such as streets, driveways, parking lots, sidewalks, curbs, and gutters where rain can readily pick up the loose material and carry it to the nearest stormwater conveyance. Small amounts of excess concrete, grout, and mortar can be disposed of in the trash.
- Storm drain covers or similarly effective containment devices must be placed over all nearby drains at the beginning of each day. Shovel or vacuum slurry and remove from the site. All accumulated runoff and solids must be collected and properly disposed at the end of each workday, or more often if necessary.
- Exposed aggregate washing, where the top layer of unhardened concrete is hosed or scraped off to leave a rough finish, must be done with a mechanism for containment and collection of the discarded concrete slurry (such as the storm drain covers mentioned above). The easiest way to contain the washwater will be to direct the washings to a hole in the ground where the water can percolate into the ground and the solids later covered with soil.
- If directed to a drain, a catch basin filter insert must be used to remove the solids. This is especially useful if the activity must proceed on rainy days.
- Cleaning of concrete application and mixing equipment or concrete vehicles on the work site must be done in a designated area where the rinse water is controlled. The rinse water must either be collected for proper disposal or put into a hole in the ground where the water can percolate away, and the solids later covered with soil or recovered and disposed or recycled.

The use of any treatment BMP must not result in the violation of groundwater, surface water, or drinking water quality standards.

8.10 Control Dewatering

Most proposed improvements are above the observed groundwater, with the exception of some utility installment. Should groundwater be encountered during construction, dewatering control measures shall be used to prevent untreated discharge of sediment-laden water. Clean dewatering shall not be routed through stormwater sediment ponds. Measures may include vehicle transport offsite for legal disposal in a manner that does not pollute surface waters, or use of a sedimentation bag with outfall to a ditch or swale for small volumes of localized dewatering (if approved by the AHJ).

8.11 Maintain BMPs

Temporary and permanent erosion and sediment control BMPs shall be maintained and repaired as needed to assure performance of their intended functions.

Sediment control BMPs such as silt fencing and drain inlet protection shall be inspected weekly or after a runoff-producing event. Temporary erosion and sediment control BMPs will be removed within 30 days after final site stabilization is achieved. The following inspection and maintenance practices will be used to maintain erosion and sediment controls:

- Built-up sediment will be removed from silt fencing when it has reached one-third the height of the fence.

- Silt fences will be inspected for depth of sediment, tears in the fabric, attachment to the fence posts, and to determine that fence posts are firmly in the ground. Accumulated sediment will be removed from behind the fence.
- Temporary and permanent seeding will be inspected for bare spots, washouts, and healthy growth.
- The Contractor Certified Erosion and Sedimentation Control Lead (CESCL) will provide erosion control inspection services and stormwater disposal monitoring through construction. The City Inspector will be notified of daily construction activities and scheduled meetings between the Erosion Control Inspector and the Contractor.

The maintenance inspection report will be made after each inspection. Copies of the report forms to be completed by the SWPPP Coordinator are attached as Appendix G of this Construction SWPPP. Completed forms will be provided to the City Inspector and will also be maintained onsite during the entire construction project. If construction activities or design modifications are made to the site plan that could impact stormwater, or if AHBL determines that the measures are not adequate to prevent erosion and the discharge of sediment from the site (based on turbidity measurements), this Construction SWPPP will be amended appropriately. The amended Construction SWPPP will have a description of the new activities that contribute to the increased pollutant loading and the planned source control activities.

8.12 Manage the Project

The following practices will be required during construction to properly manage activities:

- Comply with seasonal work limitations.
- Inspect, maintain, and repair BMPs.
- Identify a Certified Erosion and Sediment Control Lead (CESCL).
- Maintain the Construction SWPPP onsite at all times, including narrative and plans.

9.0 Construction Sequence and Phasing

9.1 Construction Sequence

The construction sequence is described below:

1. Arrange and attend a pre-construction meeting with the City of Puyallup.
2. Stake/flag clearing and construction limits.
3. Construct all temporary erosion control BMPs according to the TESC plan. Install inlet sediment protection in existing catch basins.
4. Install construction entrance.
5. Demolish existing site features indicated for removal.
6. Maintain erosion control measures in accordance with City of Puyallup standards and manufacturer recommendations.

7. Rough grade and fill site. All grading shall be done in conformance with the grading plan.
8. Construct storm system and install inlet sediment protection to new basins.
9. Install all remaining site utilities and associated infrastructure.
10. Apply erosion control mulch and seeding, straw mulch or equal, to areas that will not be brought to final grade or permanently vegetated within 7 days of exposure during the dry season, and 2 days of exposure during the wet season (October 1 – April 30).
11. Relocate erosion control measures or install new measures so that, as the site conditions change, the erosion and sediment control is always in accordance with the City of Puyallup Construction SWPPP minimum requirements.
12. Final grade site and install final surface treatments. Ensure that surface water is positively directed toward proposed storm collection facilities.
13. Remove remaining temporary erosion control items once site has been stabilized and upon approval of the City of Puyallup.

9.2 Construction Phasing

Work under this permit will be completed in one phase. Refer to the associated Plans.

10.0 Construction Schedule

Construction is scheduled to begin in TBD and is expected to be completed in TBD. The majority of earth moving activities will be scheduled during the dry season. During construction, measures will be taken to prevent the transportation of sediment from the site to receiving waters. These measures include the use of:

- Preserving Natural Vegetation (BMP C101)
- Stabilized Construction Entrance (BMP C105)
- Construction Road / Parking Area Stabilization (BMP C107)
- Temporary and Permanent Seeding (BMP C120)
- Mulching (BMP C121)
- Nets and Blankets (BMP C122)
- Plastic Covering (BMP C123)
- Dust Control (BMP C140)
- Materials on Hand (BMP C150)
- Concrete Handling (BMP C151)
- Sawcutting and Surfacing Pollution Prevention (BMP C152)
- Material Delivery, Storage, and Containment (BMP C153)
- Interceptor Swale (BMP C200)
- Check Dams (BMP C207)
- Storm Drain Inlet Protection (BMP C220)
- Silt Fence (BMP C233)
- Sediment Trap (BMP C240)

11.0 Financial/Ownership Responsibilities

The contractor is responsible for obtaining performance and maintenance bonds in accordance with City of Puyallup requirements.

12.0 Certified Erosion and Sediment Control Lead (CESCL)

The General Contractor shall be required to provide a CESCL prior to construction. Once this individual is identified, the City Inspector will be notified.

The Contractor will designate their CESCL here:

Name: _____

Address: _____

Phone: _____

Fax Number: _____

The CESCL is required to meet DOE certification requirements. The City Inspector will be provided with CESCL information.

The duties of the CESCL include:

- Implement the Construction SWPPP/TESC plan with the aid of the SWPP Team.
- Oversee maintenance practices identified as BMPs in the Construction SWPPP.
- Conduct or provide for inspection and monitoring activities.
- Sample stormwater for turbidity using a turbidity meter.
- Identify other potential pollutant sources and make sure they are added to the plan.
- Identify any deficiencies in the Construction SWPPP and make sure they are corrected.
- Ensure that any changes in construction plans are addressed in the Construction SWPPP.

To aid in the implementation of the Construction SWPPP, the members of the SWPP Team include the following: General Contractor, CESCL, City of Puyallup Inspector, City of Puyallup, the geotechnical engineering consultant, and AHBL.

The General Contractor will ensure that all housekeeping and monitoring procedures are implemented, while the CESCL will ensure the integrity of the structural BMPs. The SWPP Team will observe construction and erosion control practices and recommend revisions or additions to the Construction SWPPP and drawings.

Pollution Prevention Team

Title	Name(s)	Phone Number
Certified Erosion and Sediment Control Lead (CESL)	TBD	
Resident Engineer	Todd Sawin (AHBL)	(253) 383-2422
Emergency Ecology Contact	TBD	
Emergency Permittee / Owner Contact	TBD	
Non-Emergency Owner Contact	TBD	

Monitoring Personnel	TBD	
Ecology Regional Office	Southwest Regional Office – Lacey	(360) 407-6300

13.0 Monitoring and Sampling Requirements

Monitoring includes visual inspection, sampling for water quality parameters of concern, and documentation of the inspection and sampling findings in a logbook. A site logbook will be maintained for all on-site construction activities and will include:

- A record of the implementation of the CSWPPP and other permit requirements
- Site inspections
- Stormwater sampling data

File a blank form from under Appendix G.

The site log book must be maintained on-site within reasonable access to the site and be made available upon request to Ecology or the City of Puyallup.

13.1 Site Inspection

Site inspections will be conducted at least once every calendar week and within 24 hours following any discharge from the site. For sites that are temporarily stabilized and inactive, the required frequency is reduced to once per calendar month.

13.2 Stormwater Quality Sampling

13.2.1 Turbidity Sampling

Requirements include calibrated turbidity meter to sample site discharges for compliance with DOE. Sampling will be conducted at all discharge points at least once per week.

The benchmark for turbidity value is 25 nephelometric turbidity units (NTU) and a transparency of at least 33 centimeters.

If the discharge's turbidity is 26 to 249 NTU **or** the transparency is less than 33 cm but equal to or greater than 6 cm, the following steps will be conducted:

1. Review the CSWPPP for compliance with Special Condition S9 (Stormwater Pollution Prevention Plan). Make appropriate revisions within 7 days of the date the discharge exceeded the benchmark.
2. Immediately begin the process to fully implement or maintain appropriate source control and/or treatment BMPs as soon as possible. Address the problems within 10 days of the date the discharge exceeded the benchmark. If installation of necessary treatment BMPs is not feasible within 10 days, Ecology may approve additional time when the Permittee requests an extension within the initial 10-day response period.
3. Document BMP implementation and maintenance in the site logbook

If turbidity exceeds 250 NTU **or** the transparency is 6 cm or less at any time, the following steps will be conducted:

1. Telephone or submit an electronic report to the applicable Ecology Region's Environmental Report Tracking System (ERTS) within 24 hours.
 - <https://www.ecology.wa.gov/About-us/Get-involved/Report-an-environmental-issue>
 - Southwest Region (Pierce): (360) 407-6300
2. Immediately begin the process to fully implement and maintain appropriate source control and/or treatment BMPs as soon as possible. Address the problems within 10 days of the date the discharge exceeded the benchmark. If installation of necessary treatment BMPs is not feasible within 10 days, Ecology may approve additional time when the Permittee requests an extension within the initial 10-day response period
3. Document BMP implementation and maintenance in the site log book.
4. Continue to sample discharges daily until one of the following is true:
 - Turbidity is 25 NTU (or lower).
 - Transparency is 33 cm (or greater).
 - Compliance with the water quality limit for turbidity is achieved.
 - 1 - 5 NTU over background turbidity, if background is less than 50 NTU
 - 1% - 10% over background turbidity, if background is 50 NTU or greater
 - The discharge stops or is eliminated.

13.2.2 pH Sampling

pH monitoring is required for "Significant concrete work" (i.e. greater than 1000 cubic yards poured concrete or recycled concrete over the life of the project). The use of engineered soils (soil amendments including but not limited to Portland cement-treated base [CTB], cement kiln dust [CKD] or fly ash) also requires pH monitoring.

For significant concrete work, pH sampling will start the first day concrete is poured and continue until it is cured, typically three (3) weeks after the last pour.

For engineered soils and recycled concrete, pH sampling begins when engineered soils or recycled concrete are first exposed to precipitation and continues until the area is fully stabilized.

If the measured pH is 8.5 or greater, the following measures will be taken:

1. Prevent high pH water from entering storm sewer systems or surface water.
2. Adjust or neutralize the high pH water to the range of 6.5 to 8.5 su using appropriate technology such as carbon dioxide (CO₂) sparging (liquid or dry ice).
3. Written approval will be obtained from Ecology prior to the use of chemical treatment other than CO₂ sparging or dry ice.

Method for sampling pH: pH meter, pH test kit, or wide range pH indicator paper

14.0 Conclusion

This analysis is based on data and records either supplied to or obtained by AHBL, Inc. These documents are referenced within the text of the analysis. The analysis has been prepared utilizing procedures and practices within the standard accepted practices of the industry. We conclude that this project, as proposed, will not create any new problems within the existing downstream drainage system. This project will not noticeably aggravate any existing downstream problems due to either water quality or quantity.

AHBL, Inc.

Zachary Perdue, EIT
Project Engineer

ZP/

February 2024

Q:\2023\2230491\10_CIV\NON_CAD\REPORTS\CSWPPP\20240227 Rpt (CSWPPP) 2230491.docx

Appendix F

F-1 TESC Plan
F-2 TESC Notes and Details
F-3 TESC Pond Calculations

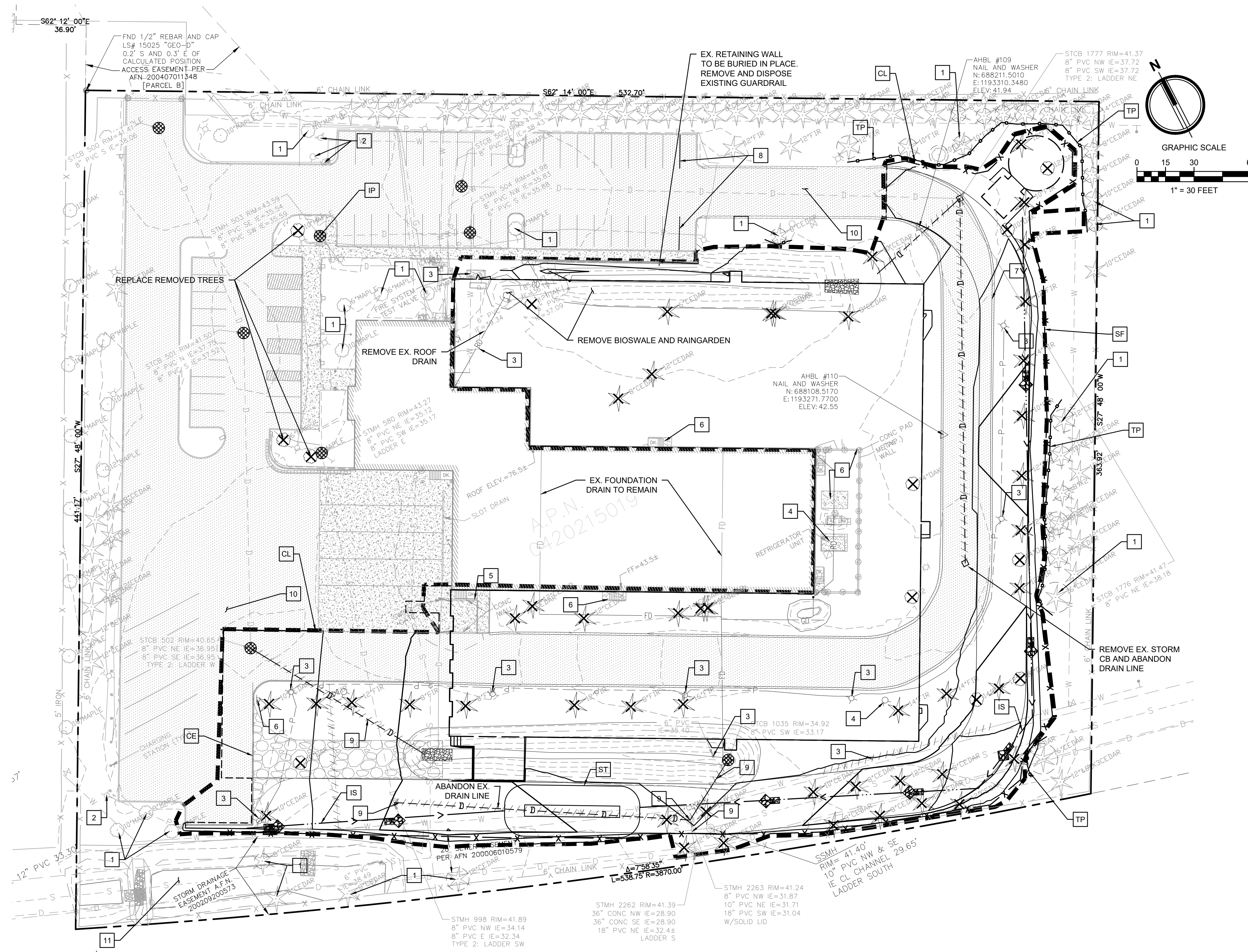

LEGEND:

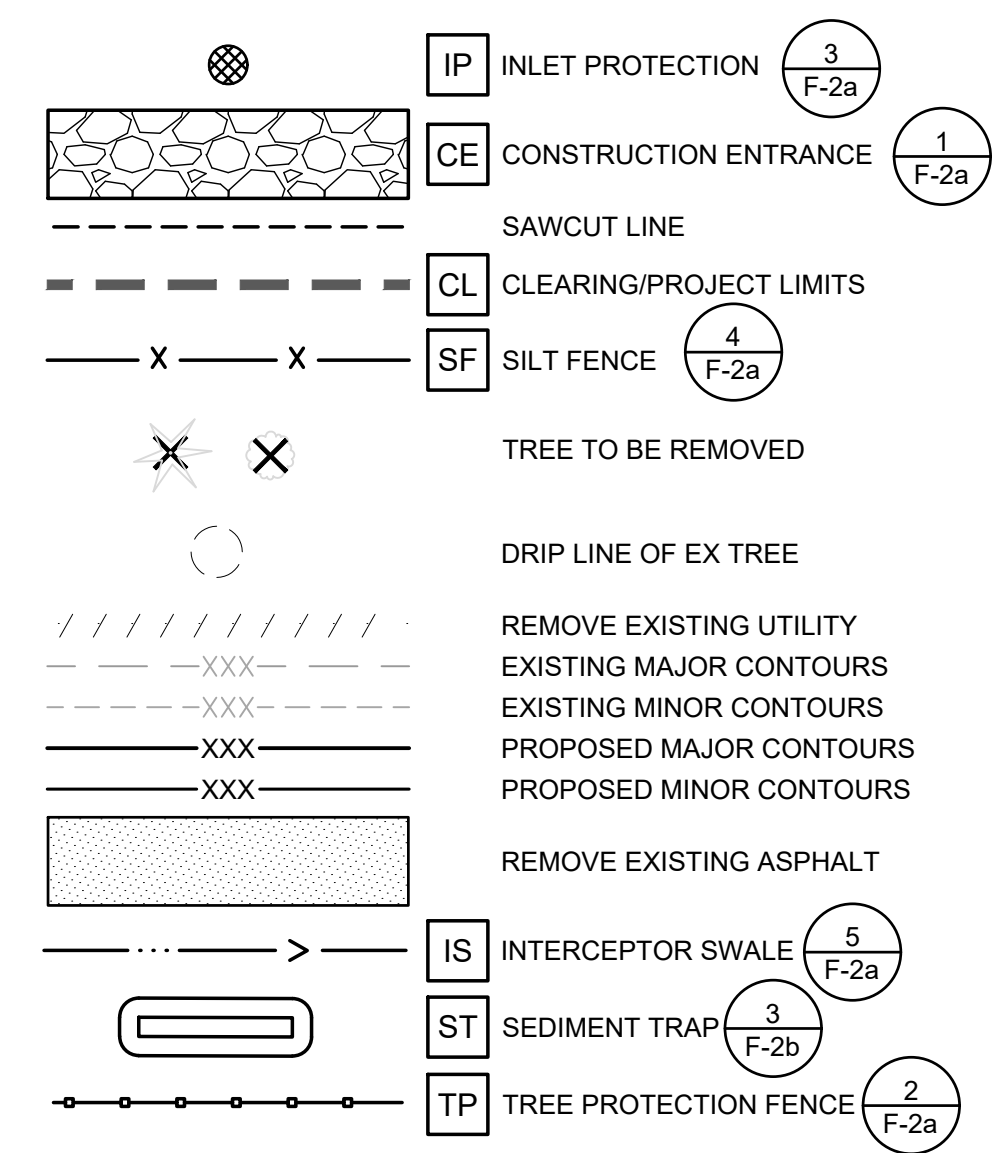

KEYNOTES

- 1 PRESERVE AND PROTECT EXISTING TREES TO REMAIN. PROVIDE TREE PROTECTION WHERE INDICATED
- 2 PRESERVE AND PROTECT EXISTING UTILITY TO REMAIN
- 3 EXISTING UTILITY POLE TO BE REMOVED
- 4 RELOCATE EXISTING FIRE HYDRANT
- 5 DEMOLISH EXISTING TRASH ENCLOSURE
- 6 EXISTING SURFACE FEATURE AND FOUNDATION TO BE REMOVED
- 7 REMOVE EXISTING ASPHALT AND CURBING
- 8 REMOVE EXISTING STRIPING
- 9 DEMOLISH EXISTING STORM PIPE OR STRUCTURE
- 10 CONTRACTOR SHALL SWEEP PAVEMENT TO PREVENT TRACKING OF SEDIMENT OFFSITE
- 11 CONTRACTOR SHALL PROTECT EXISTING STORMWATER TREATMENT SYSTEM FOR NEIGHBORING PROPERTIES

DEMOLITION NOTES

1. DEMOLITION: IT IS THE INTENT UNDER THE WORK OF THIS CONTRACT TO INCLUDE, BUT NOT LIMITED TO, THE DEMOLITION OF ALL EXISTING BUILDINGS, PAVING, UTILITIES, BOLLARDS, GATES AND OTHER EXISTING SITE IMPROVEMENTS INCLUDING THE UNDERGROUND COMPONENTS AS CLARIFIED BY THIS DRAWING. IT IS THE CONTRACTOR'S RESPONSIBILITY TO FULLY REVIEW THE SITE CONDITIONS AND TO CORRELATE THESE OBSERVATIONS WITH THE PROJECT WORK AND INCLUDE ALL NECESSARY DEMOLITION, WHETHER SHOWN OR NOT, AND INCLUDE ALL SUCH COSTS IN THE SCOPE OF WORK.
2. CLEARING: IT IS THE INTENT UNDER THE WORK OF THIS CONTRACT TO CONDUCT ALL CLEARING NECESSARY TO BE ABLE TO COMPLETE ALL THE WORK OF THIS PROJECT.
3. CONTRACTOR SHALL LEGALLY DISPOSE ALL DEMOLISHED AND REMOVED MATERIALS OFF THE OWNER'S PROPERTY UNLESS INDICATED OTHERWISE.
4. DEMOLITION WORK MAY OCCUR OUTSIDE OF PROJECT LIMIT.



Civil Engineers
Structural Engineers
Landscape Architects
Community Planners
Land Surveyors
Historians

TESC PLAN	F-1
CPFD	

- ALL LIMITS OF CLEARING AND AREAS OF VEGETATION PRESERVATION AS PRESCRIBED ON THE PLANS SHALL BE CLEARLY FLAGGED IN THE FIELD AND OBSERVED DURING CONSTRUCTION.
- ALL REQUIRED SEDIMENTATION AND EROSION CONTROL FACILITIES MUST BE CONSTRUCTED AND IN OPERATION PRIOR TO ANY LAND CLEARING AND/OR OTHER CONSTRUCTION TO ENSURE THAT SEDIMENT LADEN WATER DOES NOT ENTER THE NATURAL DRAINAGE SYSTEM. THE CONTRACTOR SHALL SCHEDULE AN INSPECTION OF THE EROSION CONTROL FACILITIES PRIOR TO ANY LAND CLEARING AND/OR CONSTRUCTION. ALL EROSION AND SEDIMENT FACILITIES SHALL BE MAINTAINED IN A SATISFACTORY CONDITION AS DETERMINED BY THE CITY, UNTIL SUCH TIME THAT CLEARING AND/OR CONSTRUCTION IS COMPLETED AND THE POTENTIAL FOR ON-SITE EROSION HAS PASSED. THE IMPLEMENTATION, MAINTENANCE, REPLACEMENT, AND ADDITIONS TO THE EROSION AND SEDIMENTATION CONTROL SYSTEMS SHALL BE THE RESPONSIBILITY OF THE PERMITEE.
- THE EROSION AND SEDIMENTATION CONTROL SYSTEM FACILITIES DEPICTED ON THESE PLANS ARE INTENDED TO BE MINIMUM REQUIREMENTS TO MEET ANTICIPATED SITE CONDITIONS. AS CONSTRUCTION PROGRESSES AND UNEXPECTED OR SEASONAL CONDITIONS DICTATE, FACILITIES WILL BE NECESSARY TO ENSURE COMPLETE SILTATION CONTROL ON THE SITE. DURING THE COURSE OF CONSTRUCTION, IT SHALL BE THE OBLIGATION AND RESPONSIBILITY OF THE PERMITEE TO ADDRESS ANY NEW CONDITIONS THAT MAY BE CREATED BY HIS ACTIVITIES AND TO PROVIDE ADDITIONAL FACILITIES, OVER AND ABOVE THE MINIMUM REQUIREMENTS, AS MAY BE NEEDED TO PROTECT ADJACENT PROPERTIES, SENSITIVE AREAS, NATURAL WATER COURSES, AND/OR STORM DRAINAGE SYSTEMS.
- APPROVAL OF THESE PLANS IS FOR GRADING, TEMPORARY DRAINAGE, EROSION AND SEDIMENTATION CONTROL ONLY. IT DOES NOT CONSTITUTE AN APPROVAL OF PERMANENT STORM DRAINAGE DESIGN, SIZE OR LOCATION OF PIPES, RESTRICTORS, CHANNELS, OR RETENTION FACILITIES.
- ANY DISTURBED AREA WHICH HAS BEEN STRIPPED OF VEGETATION AND WHERE NO FURTHER WORK IS ANTICIPATED FOR A PERIOD OF 30 DAYS OR MORE, MUST BE IMMEDIATELY STABILIZED WITH MULCHING, GRASS PLANTING, OR OTHER APPROVED EROSION CONTROL TREATMENT APPLICABLE TO THE TIME OF YEAR IN QUESTION. GRASS SEEDING ALONE WILL BE ACCEPTABLE ONLY DURING THE MONTHS OF APRIL THROUGH SEPTEMBER INCLUSIVE. SEEDING MAY PROCEED OUTSIDE THE SPECIFIED TIME PERIOD WHENEVER IT IS IN THE INTEREST OF THE PERMITEE BUT MUST BE AUGMENTED WITH MULCHING, NETTING, OR OTHER TREATMENT APPROVED BY THE CITY.
- IN CASE EROSION OR SEDIMENTATION OCCURS TO ADJACENT PROPERTIES, ALL CONSTRUCTION WORK WITHIN THE DEVELOPMENT THAT WILL FURTHER AGGRAVATE THE SITUATION MUST CEASE, AND THE OWNER/CONTRACTOR WILL IMMEDIATELY COMMENCE RESTORATION METHODS. RESTORATION ACTIVITY WILL CONTINUE UNTIL SUCH TIME AS THE AFFECTED PROPERTY OWNER IS SATISFIED.
- NO TEMPORARY OR PERMANENT STOCKPILING OF MATERIALS OR EQUIPMENT SHALL OCCUR WITHIN CRITICAL AREAS OR ASSOCIATED BUFFERS, OR THE CRITICAL ROOT ZONE FOR VEGETATION PROPOSED FOR RETENTION.

 CITY OF PUYALLUP DEVELOPMENT ENGINEERING and PUBLIC WORKS DEPARTMENTS	GRADING, EROSION, AND SEDIMENTATION CONTROL NOTES			
	<small>DESIGNED BY</small> ERM PERIN BYBORODA	<small>CHECKED BY</small> LINDA LEAN	<small>APPROVED BY</small> COLLEEN BARBER	<small>DATE APPROVED</small> 05/01/2008
<small>FILE NAME</small> I:\PROJECTS\CONSTRUCTION\ESTRUCITY\2008\GRADING.EROSION.SILTATION	<small>DATE APPROVED</small> 05/01/2008	<small>SCALE</small> 1" = 10'-0"	<small>DATE APPROVED</small> 05/01/2008	<small>CITY</small> OF PUYALLUP

DEMOLITION GENERAL NOTES

- CONTRACTOR IS RESPONSIBLE FOR ENSURING THAT ALL UTILITIES HAVE BEEN DISCONNECTED PRIOR TO COMMENCING DEMOLITION.
- DEMOLITION: IT IS THE INTENT OF THE WORK UNDER THIS CONTRACT TO INCLUDE THE DEMOLITION OF ALL EXISTING BUILDINGS, PAVING, UTILITIES AND OTHER EXISTING SITE IMPROVEMENTS INCLUDING THEIR UNDERGROUND COMPONENTS AS INDICATED BY THIS DRAWING AND AS REQUIRED FOR NEW CONSTRUCTION. IT IS THE CONTRACTOR'S RESPONSIBILITY TO FULLY REVIEW THE SITE CONDITIONS AND TO CORRELATE THESE OBSERVATIONS WITH THE PROJECT WORK AND INCLUDE ALL NECESSARY DEMOLITION, WHETHER SHOWN OR NOT, AND INCLUDE ALL SUCH COSTS IN THE BASE BID.
- CLEARING: IT IS THE INTENT OF THE WORK UNDER THIS CONTRACT TO CONDUCT ALL CLEARING NECESSARY TO BE ABLE TO COMPLETE ALL THE WORK OF THIS PROJECT.
- CONTRACTOR SHALL LEGALLY DISPOSE OF THE OWNER'S PROPERTY, ALL DEMOLISHED AND REMOVED MATERIALS, UNLESS INDICATED OTHERWISE.
- IT IS THE RESPONSIBILITY OF THE CONTRACTOR TO COMPLETELY COORDINATE UTILITY DEMOLITION WITH NEW CONSTRUCTION.
- ANY ABANDONED SIDE SEWER(S) SHALL BE PLUGGED OR CAPPED PER CITY OF PUYALLUP STANDARDS.
- CONTRACTOR SHALL MINIMIZE DUST GENERATION ONSITE BY SPRINKLING THE SITE WITH WATER UNTIL SURFACE IS WET.
- REMOVE CONCRETE SIDEWALK AT THE NEAREST JOINT, UNLESS NOTED OTHERWISE.
- THIS PLAN IS USED IN CONJUNCTION WITH THE CSWPPP AND NPDES CONSTRUCTION STORM WATER PERMIT.
- ANY EXISTING UNDERGROUND STORAGE TANK TO BE REMOVED/ABANDONED PER DOE/DOH REGULATIONS. PROVIDE DOCUMENTATION OF REMOVAL/ABANDONMENT TO CITY INSPECTOR.
- COORDINATE TREE REMOVAL/RETENTION WITH LANDSCAPE PLANS.

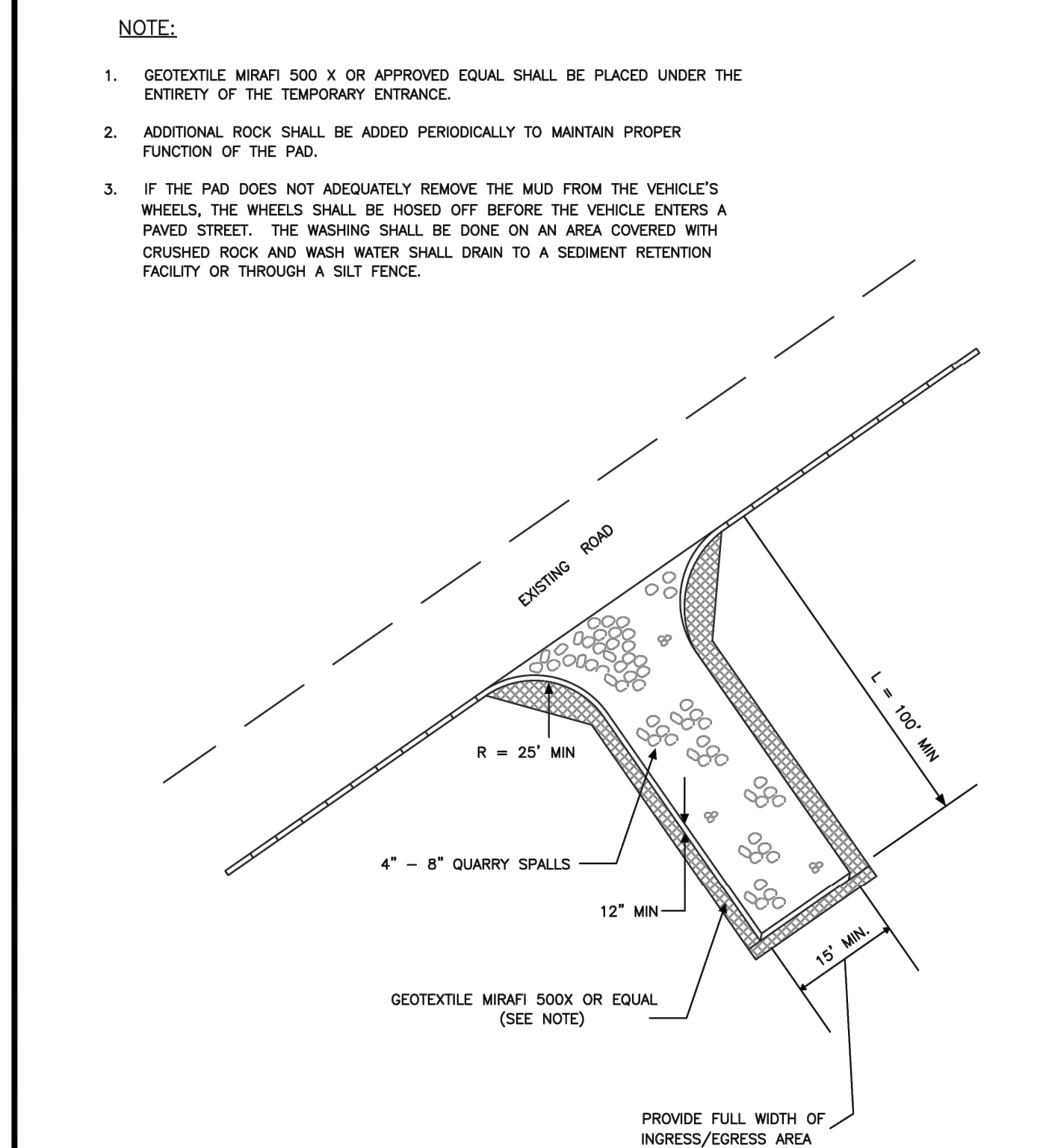

 CITY OF PUYALLUP DEVELOPMENT ENGINEERING and PUBLIC WORKS DEPARTMENTS	TEMPORARY CONSTRUCTION ENTRANCE			
	<small>DESIGNED BY</small> ERM PERIN BYBORODA	<small>CHECKED BY</small> LINDA LEAN	<small>APPROVED BY</small> COLLEEN BARBER	<small>DATE APPROVED</small> 05/01/2008
<small>FILE NAME</small> I:\PROJECTS\CONSTRUCTION\ESTRUCITY\2008\GRADING.EROSION.SILTATION	<small>DATE APPROVED</small> 05/01/2008	<small>SCALE</small> 1" = 10'-0"	<small>DATE APPROVED</small> 05/01/2008	<small>CITY</small> OF PUYALLUP

1 CONSTRUCTION ENTRANCE

NOT TO SCALE

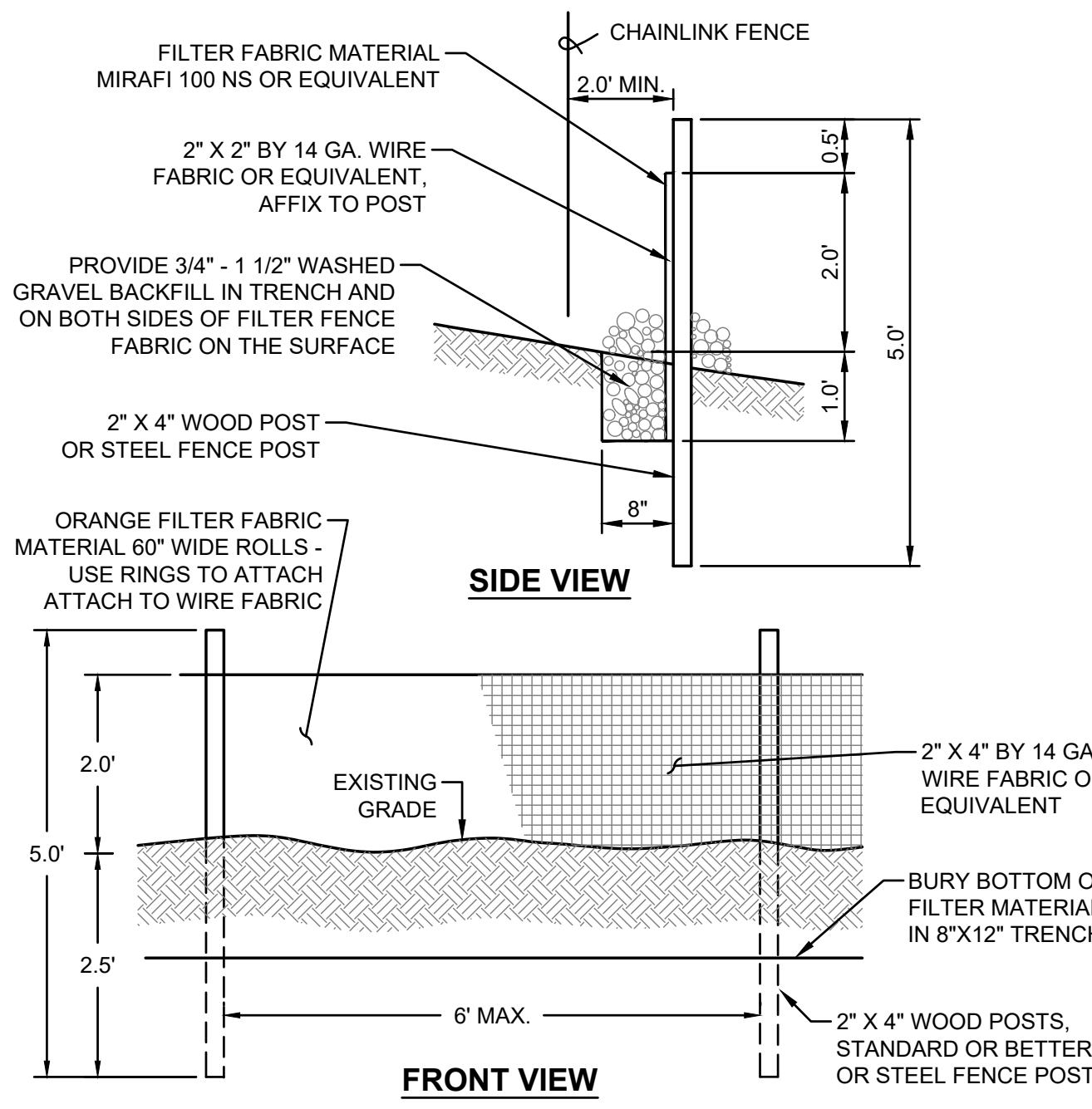

4 SILT FENCE

NOT TO SCALE

NOTES:

- THE FILTER FABRIC SHALL BE PURCHASED IN A CONTINUOUS ROLL CUT TO THE LENGTH OF THE BARRIER TO AVOID USE OF JOINTS. WHEN JOINTS ARE NECESSARY, FILTER CLOTH SHALL BE SPICED TOGETHER ONLY AT A SUPPORT POST WITH A MINIMUM SIX-INCH OVERLAP, AND BOTH ENDS SECURELY FASTENED TO THE POST.
- THE FILTER FABRIC FENCE SHALL BE INSTALLED TO FOLLOW THE CONTOURS (WHERE FEASIBLE). THE FENCE POSTS SHALL BE SPACED A MAXIMUM OF SIX FEET APART AND DRIVEN SECURELY INTO THE GROUND (MINIMUM OF 30").
- A TRENCH SHALL BE EXCAVATED, ROUGHLY EIGHT INCHES WIDE AND TWELVE INCHES DEEP, UPSLOPE AND ADJACENT TO THE WOOD POST TO ALLOW THE FILTER FABRIC TO BE BURIED.
- WHEN STANDARD STRENGTH FILTER FABRIC IS USED, A WIRE MESH SUPPORT FENCE SHALL BE FASTENED SECURELY TO THE UPSLOPE SIDE OF THE POSTS USING HEAVY-DUTY WIRE STAPLES AT LEAST ONE INCH LONG, TIE WIRES, OR HOG RINGS. THE WIRE SHALL EXTEND INTO THE TRENCH A MINIMUM OF FOUR INCHES AND SHALL NOT EXTEND MORE THAN THIRTY SIX INCHES ABOVE THE ORIGINAL GROUND SURFACE.
- THE STANDARD STRENGTH FILTER FABRIC SHALL BE STAPLED OR WIRED TO THE FENCE, AND TWENTY INCHES OF THE FABRIC SHALL BE EXTENDED INTO THE TRENCH. THE FABRIC SHALL NOT EXTEND MORE THAN THIRTY SIX INCHES ABOVE THE ORIGINAL GROUND SURFACE. FILTER FABRIC SHALL NOT BE STAPLED TO EXISTING TREES.
- WHEN EXTRA-STRENGTH FILTER FABRIC AND CLOSER POST SPACING ARE USED, THE WIRE MESH SUPPORT FENCE MAY BE ELIMINATED. IN SUCH A CASE, THE FILTER FABRIC IS STAPLED OR WIRED DIRECTLY TO THE POSTS WITH ALL OTHER PROVISIONS OF STANDARD NOTE (S) APPLYING.
- THE TRENCH SHALL BE BACKFILL WITH 3/4 INCH MINIMUM DIAMETER WASHED GRAVEL.
- FILTER FABRIC FENCES SHALL BE REMOVED WHEN THEY HAVE SERVED THEIR USEFUL PURPOSE, BUT NOT BEFORE THE UPSLOPE AREA HAS BEEN PERMANENTLY STABILIZED.
- FILTER FABRIC FENCES SHALL BE INSPECTED IMMEDIATELY AFTER EACH RAINFALL AND AT LEAST DAILY DURING PROLONGED RAINFALL. ANY REQUIRED REPAIRS SHALL BE MADE IMMEDIATELY.
- CONTRIBUTING LENGTH TO FENCE SHALL NOT BE MORE THAN 100 FEET.
- DO NOT INSTALL BELOW AN OUTLET PIPE OR WEIR.
- DO NOT DRIVE OVER OR FILL OVER FILTER FABRIC FENCE.

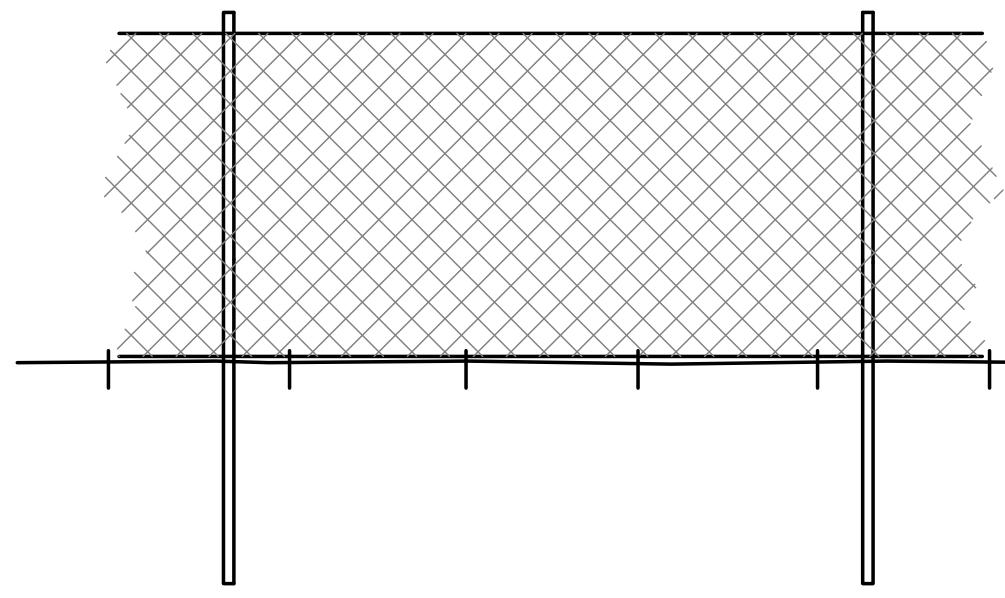

- THE TREE PROTECTION FENCE SHOULD BE MAINTAINED THROUGHOUT GRADING AND CONSTRUCTION AND SHALL NOT BE REMOVED UNTIL FINAL LANDSCAPING IS IN PROGRESS. AT NO TIME SHALL EQUIPMENT ENTER INTO THE ROOT PROTECTION ZONE (RPZ). ALL BRUSH CLEANUP WITHIN THE RPZ SHOULD BE COMPLETED BY HAND TO PREVENT DISTURBANCE OF NATIVE GROUND COVERS. NO CUTS OR FILLS OF UTILITY TRENCHING, MODIFICATIONS TO DRAINAGE, ETC. SHALL IMPACT THE RPZ. NO WIRES, CABLES, OR OTHER DEVICES SHOULD BE ATTACHED TO PROTECTED TREES DURING CONSTRUCTION.
- IF IMPACTS MUST OCCUR WITHIN THE RPZ, CONTACT THE LANDSCAPE ARCHITECT PRIOR TO THE OPERATIONS TO DETERMINE THE PROPER PROCEDURE TO PROTECT THE TREES HEALTH.
- CONTRACTOR SHALL REFER TO SPECIFICATIONS FOR ADDITIONAL INFORMATION.

2 TREE PROTECTION FENCE

NOT TO SCALE

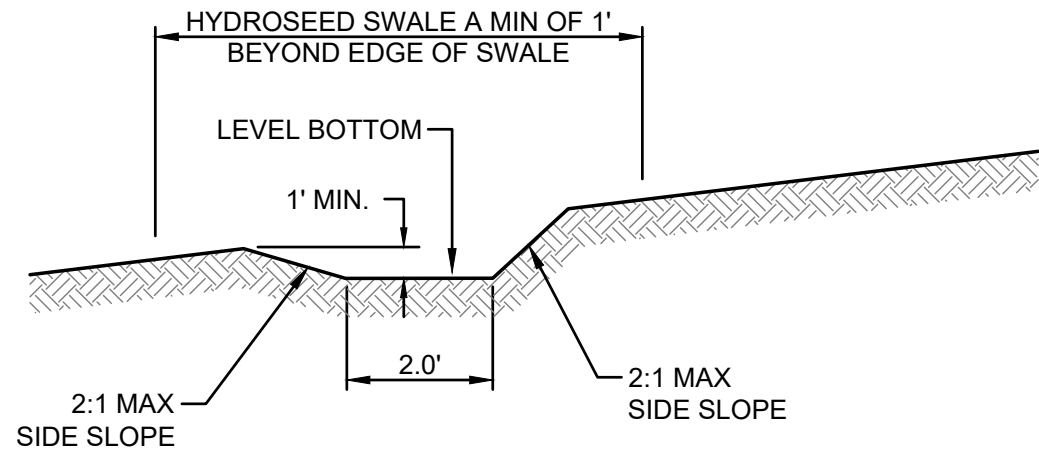

5 INTERCEPTOR SWALE

NOT TO SCALE

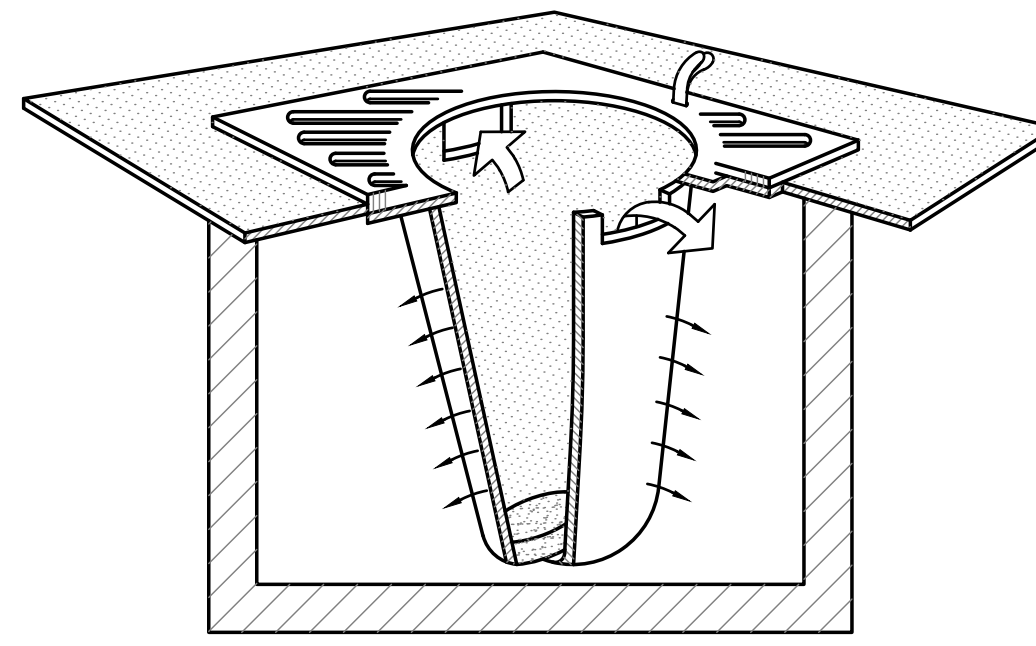

- NOTES:**
- FILTERS SHALL BE INSPECTED AFTER EACH STORM EVENT AND CLEANED OR REPLACED WHEN 1/3 FULL.
 - INSTALL INLET PROTECTION IN ALL NEW STORM STRUCTURES THAT WILL COLLECT STORMWATER AS THEY ARE INSTALLED.

3 INLET PROTECTION

NOT TO SCALE

PLASTIC COVERING NOTES

- PLASTIC SHEETING SHALL HAVE A MINIMUM THICKNESS OF 6 MILS AND SHALL MEET THE REQUIREMENTS OF THE WASHINGTON STATE DEPARTMENT OF TRANSPORTATION STANDARD SPECIFICATIONS SECTION 9-14.5(3).
- COVERING SHALL BE INSTALLED AND MAINTAINED TIGHTLY IN PLACE BY USING SANDBAGS OR TIRES ON ROPES WITH A MAXIMUM 10-FOOT GRID SPACING IN ALL DIRECTIONS. ALL SEAMS SHALL BE TAPED OR WEIGHTED DOWN FULL LENGTH. SEAMS SHALL HAVE AT LEAST A 12 INCH OVERLAP.
- CLEAR PLASTIC COVERING SHALL BE INSTALLED IMMEDIATELY ON AREAS SEEDED BETWEEN NOVEMBER 1 AND MARCH 31 AND REMAIN UNTIL VEGETATION IS FIRMLY ESTABLISHED.
- WHEN COVERING IS USED ON UN-SEEDED SLOPES, IT SHALL BE KEPT IN PLACE UNTIL THE NEXT SEEDING PERIOD.
- PLASTIC COVERING SHALL BE BURIED TWO FEET AT THE TOP OF SLOPES IN ORDER TO PREVENT SURFACE WATER FLOW BENEATH SHEETS.
- PROPER MAINTENANCE OF COVERING INCLUDES, BUT IS NOT NECESSARILY LIMITED TO, REGULAR CHECKS FOR AND REPAIRS OF RIPS AND DISLODGED ENDS.

ESC MAINTENANCE REQUIREMENTS:

- EROSION AND SEDIMENTATION CONTROL FACILITIES SHALL BE INSPECTED AFTER EACH STORM EVENT AND DAILY DURING PROLONGED RAINFALL.
- NECESSARY REPAIRS OR REPLACEMENT OF FACILITIES SHALL BE ACCOMPLISHED PROMPTLY.
- SEDIMENT DEPOSITS SHALL BE REMOVED AFTER EACH STORM EVENT OR WHEN THE LEVEL OF DEPOSITION REACHES APPROXIMATELY ONE-HALF THE MAXIMUM POTENTIAL DEPTH.
- SEDIMENT DEPOSITS REMAINING IN PLACE AFTER THE ESC FACILITIES ARE NO LONGER REQUIRED SHALL BE DRESSED TO CONFORM TO THE EXISTING GRADE, PREPARED AND SEEDED.
- TEMPORARY EROSION AND SEDIMENTATION CONTROL FACILITIES SHALL BE MAINTAINED BY:

ESC HYDROSEEDING NOTES

- HYDROSEEDING SHALL BE APPLIED TO ALL DISTURBED NON-PAVED SURFACES WHERE INDICATED.
- HYDROSEEDING TO BE THE FOLLOWING MIXTURE:

TYPE OF MIXTURE	PROPORTIONS BY WEIGHT	PERCENT PURITY	PERCENT GERMINATION
PERENNIAL RYE GRASS	40%	90%	90%
CREeping RED FESCUE	40%	90%	90%
PREINOCULATED WHITE DUTCH CLOVER	10%	95%	90%
COLONIAL BENT GRASS	10%	90%	90%
- APPLICATION TO BE 100 LBS/ACRE.
- 500 LBS/ACRE 10-20-20 FERTILIZER, 2000 LBS/ACRE MULCH AND 40 LBS/ACRE SOIL STABILIZER TO BE APPLIED WITH SEED MIXTURE.



AHBL
 TACOMA · SEATTLE
 2215 North 30th Street, Suite 300, Tacoma, WA 98403 253.383.2422 TEL.
 316 Occidental Avenue South, Suite 330, Seattle, WA 98104 206.267.2425 TEL.

TESC PLAN DETAILS CPF D	F-2a
---------------------------------------	------

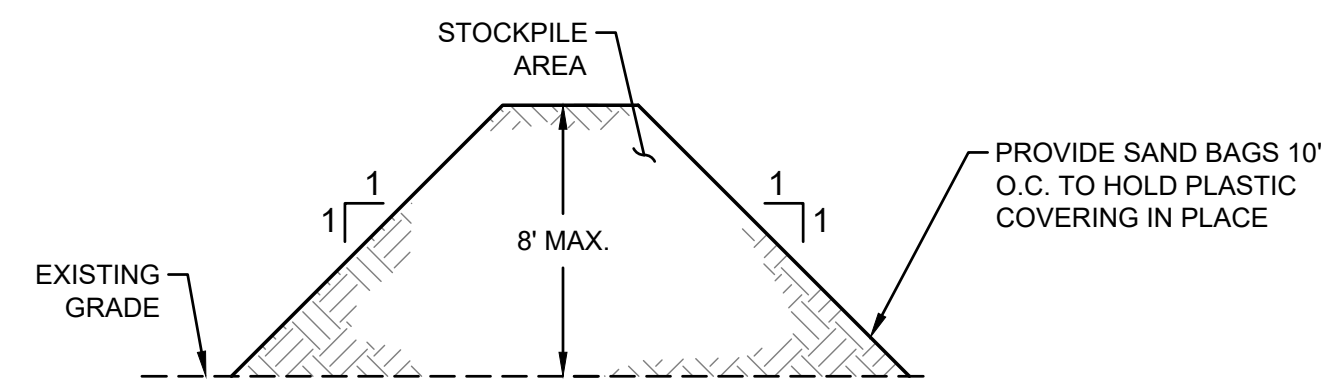

- NOTES:
1. STOCKPILES SHALL BE STABILIZED WITH PLASTIC COVERING OR OTHER APPROVED DEVICE.
 2. SEDIMENT LEACHING FROM STOCKPILES SHALL BE PREVENTED DURING ALL SEASONS.

SOIL STOCKPILE NOTES

1. STOCKPILES SHALL BE STABILIZED (WITH PLASTIC COVERING OR OTHER APPROVED DEVICE) DAILY BETWEEN NOVEMBER 1 AND MARCH 31.
2. IN ANY SEASON, SEDIMENT LEACHING FROM STOCK PILES MUST BE PREVENTED.
3. TOPSOIL SHALL NOT BE PLACED WHILE IN A FROZEN OR MUDDY CONDITION, WHEN THE SUBGRADE IS EXCESSIVELY WET, OR WHEN CONDITIONS EXIST THAT MAY OTHERWISE BE DETRIMENTAL TO PROPER GRADING OR PROPOSED SODDING OR SEEDING.
4. PREVIOUSLY ESTABLISHED GRADES ON THE AREAS TO BE TOPSOILED SHALL BE MAINTAINED ACCORDING TO THE APPROVED PLAN.
5. ALL STOCKPILES SHALL BE COVERED WITH PLASTIC COVERING. SEE PLASTIC COVERING NOTES ON THIS SHEET.

1 STOCKPILE COVERING

NOT TO SCALE

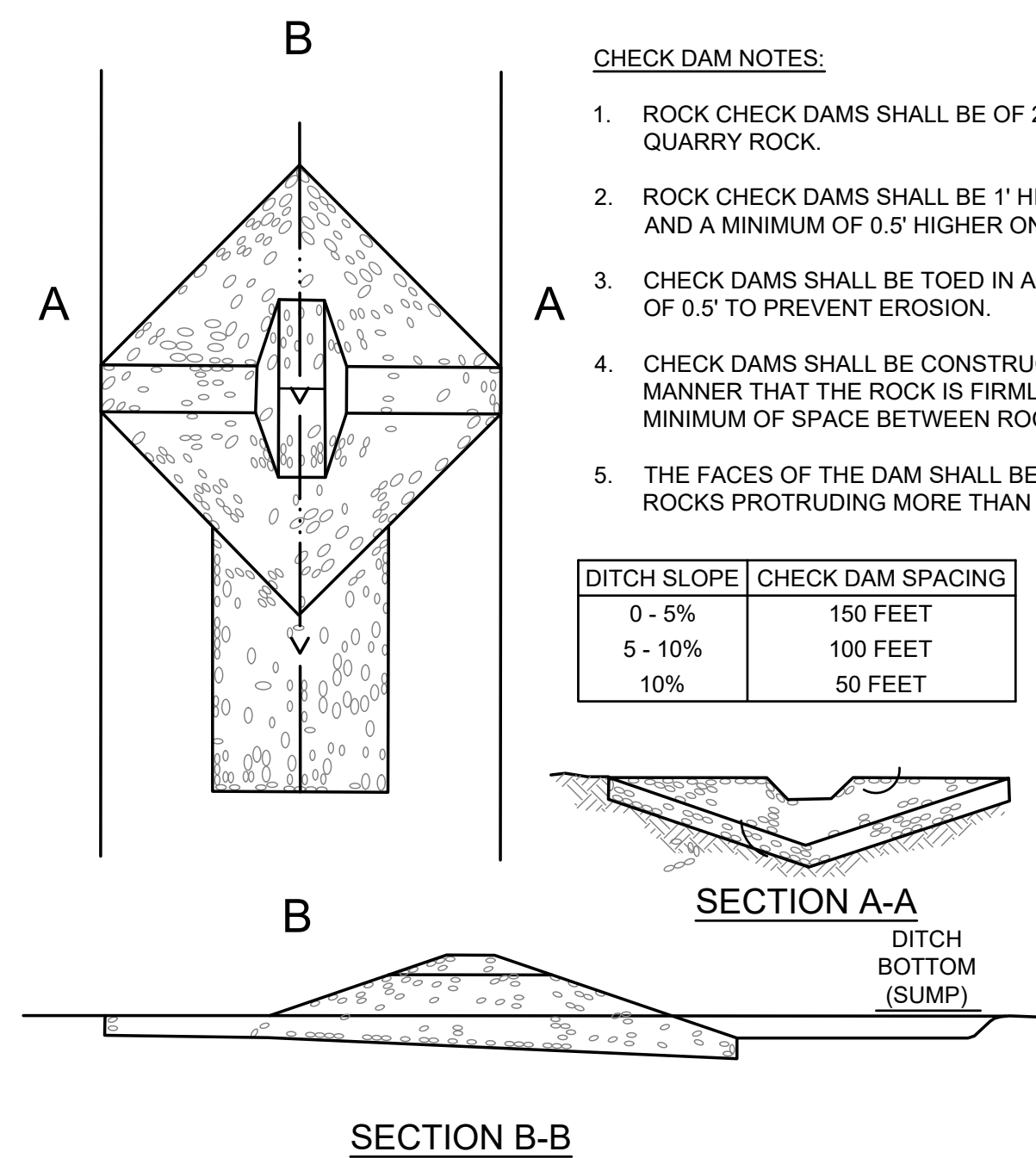

CHECK DAM NOTES:

1. ROCK CHECK DAMS SHALL BE OF 2" TO 8" FACE, SOUND QUARRY ROCK.
2. ROCK CHECK DAMS SHALL BE 1' HIGH IN THE CENTER AND A MINIMUM OF 0.5' HIGHER ON THE SIDES.
3. CHECK DAMS SHALL BE TOED IN AT THE BASE A MINIMUM OF 0.5' TO PREVENT EROSION.
4. CHECK DAMS SHALL BE CONSTRUCTED IN SUCH A MANNER THAT THE ROCK IS FIRMLY PLACED WITH A MINIMUM OF SPACE BETWEEN ROCKS.
5. THE FACES OF THE DAM SHALL BE SMOOTH WITH NO ROCKS PROTRUDING MORE THAN 2".

DITCH SLOPE	CHECK DAM SPACING
0 - 5%	150 FEET
5 - 10%	100 FEET
10%	50 FEET

2 ROCK CHECK DAM

NOT TO SCALE

Figure II-3.26: Cross Section of Sediment Trap

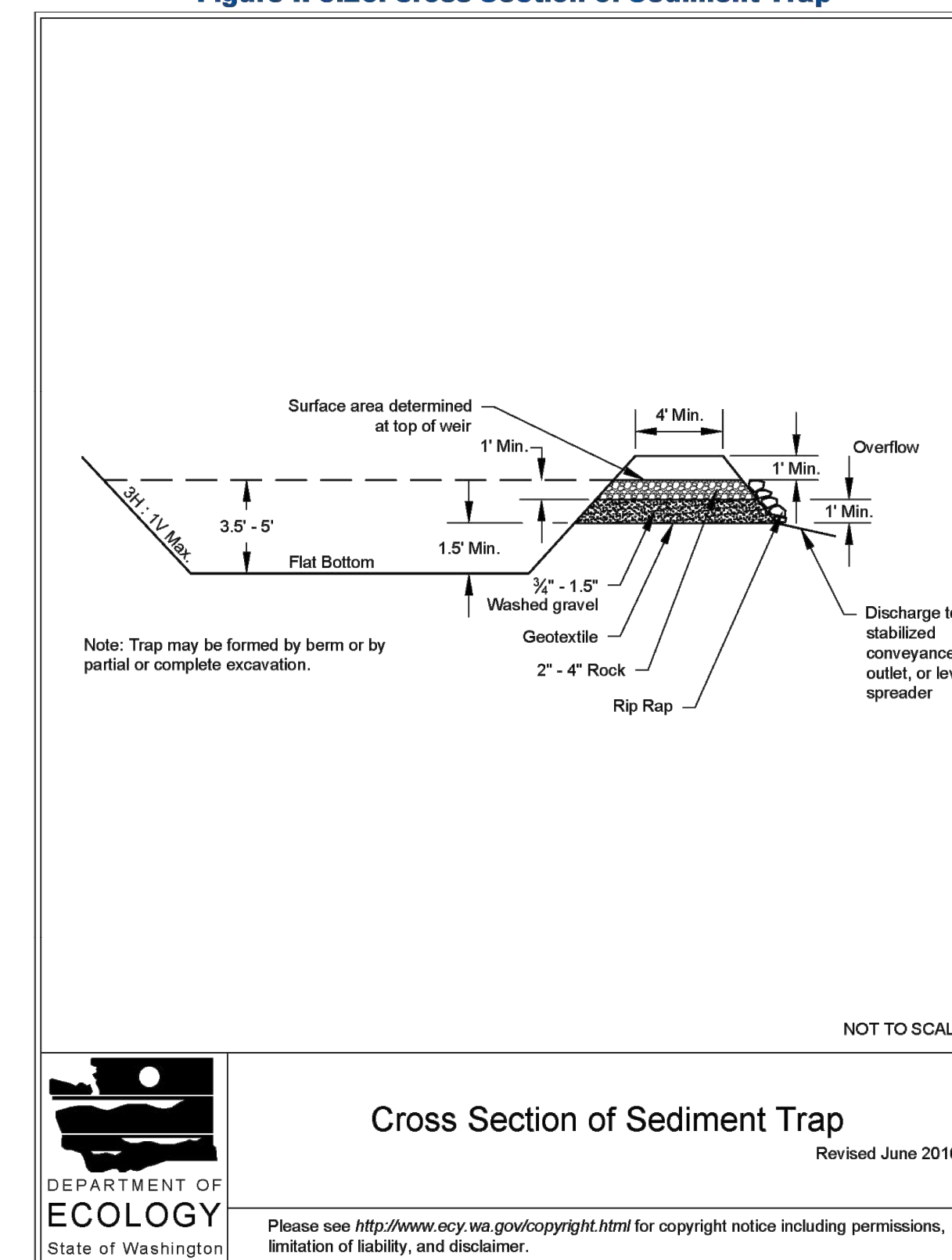

NOT TO SCALE

Cross Section of Sediment Trap

Revised June 2016



Please see <http://www.ecy.wa.gov/copyright.html> for copyright notice including permissions, limitation of liability, and disclaimer.

2019 Stormwater Management Manual for Western Washington
Volume II - Chapter 3 - Page 386

3 TEMPORARY SEDIMENT TRAP

NOT TO SCALE



Civil Engineers
Structural Engineers
Landscape Architects
Community Planners
Land Surveyors
Geologists

TESC PLAN DETAILS

CPFD

F-2b

Flow Frequency	
Flow(cfs)	0801 15m
2 Year	= 0.1082
5 Year	= 0.2149
10 Year	= 0.3169
25 Year	= 0.4909
50 Year	= 0.6599
100 Year	= 0.8688

Basin 1 Mitigated	
Subbasin Name:	Basin 1
Flows To:	Surface Interflow
Area in Basin	
Available Pervious	Acres
<input checked="" type="checkbox"/> C, Lawn, Flat	2.26

FLOW RATE

CLEARING LIMITS AREA

QUOTE FROM CITY OF PUYALLUP CIVIL PERMIT DESIGN CHECKLIST

Projects larger than one acre: include a temporary detention facility with storage volume equal to a 100-year (yr)/24-hour (hr) storm event

TRAP SIZE FORMULA FROM BMP C240

Therefore, the equation for computing sediment trap surface area becomes:

$$SA = 2 \times Q_2 / 0.00096$$

or

Q₁₀₀

2080 square feet per cfs of inflow

CALCS:

$$SA = 2080 \times 0.8688 = 1808 \text{ SF}$$

PROPOSED POND SIZE 6' X 50' BOTTOM DIMENSIONS
3:1 SIDE SLOPES, 3.5' PONDING DEPTH

$$\text{TOP AREA} = 27' \times 71' = 1917 \text{ SF}$$

$$1917 \text{ SF} > 1808 \text{ SF}$$

Appendix G

Inspection Logs

CPFD

**Stormwater Pollution Prevention Plan
Inspection and Maintenance Report Form**

To be completed every 7 days and within 24 hours of a rainfall event of 0.5 inches or more

Inspector: _____ Date: _____

Inspector's Qualifications: _____

Days since last rainfall: _____ Amount of last rainfall: _____ inches

Stabilization Measures

Drainage Area	Date Since Last Disturbance	Date of Next Disturbance	Stabilized (yes/No)	Stabilized With	Condition

Stabilization required: _____

To be performed by: _____ On or before: _____

CPFD
Stormwater Pollution Prevention Plan
Inspection and Maintenance Report Form

Site Entrance:

Date:

Temporary Construction Entrance

Drainage Area Perimeter	Does Rock Pad Adequately Remove Mud from Vehicle Wheels?	Is Rock Pad Clogged with Mud?	Have Quarry Spalls Been Moved to the Roadway?

Maintenance required for temporary construction entrances:

To be performed by: _____ On or before: _____

CPFD
Stormwater Pollution Prevention Plan
Inspection and Maintenance Report Form

Perimeter Structural Controls:

Date:

Silt Fence

Drainage Area Perimeter	Has Silt Reached 1/3 of Fence Height?	Is Fence Properly Secured?	Is There Evidence of Washout or Overtopping?

Maintenance required for silt fence and straw bales:

To be performed by: _____ On or before: _____

CPFD
Stormwater Pollution Prevention Plan
Inspection and Maintenance Report Form

Inlet Protection:

Date:

Storm Drain Barriers

Inlet	Has Silt Reached 1/3 of Barrier Height?	Is Barrier Properly Secured?	Is There Evidence of Washout or Overtopping?

Maintenance required for storm drain barriers:

To be performed by: _____ On or before: _____

CPFD
Stormwater Pollution Prevention Plan
Inspection and Maintenance Report Form

Changes required to the pollution prevention plan:

Reasons for changes:

I certify under penalty of law that this document and all attachments were prepared under my direction or supervision in accordance with a system designed to assure that qualified personnel properly gathered and evaluated the information submitted. Based on my inquiry of the person or persons who manage the system, or those persons directly responsible for gathering the information, the information submitted is, to the best of my knowledge and belief, true, accurate, and complete. I am aware that there are significant penalties for submitting false information, including the possibility of fine and imprisonment for knowing violations.

Signature: _____ Date: _____

Appendix H

Best Management Practices (BMPs)

BMP C101	Preserving Natural Vegetation
BMP C103	High Visibility Fence
BMP C105	Stabilized Construction Entrance
BMP C107	Construction Road / Parking Area Stabilization
BMP C120	Temporary and Permanent Seeding
BMP C121	Mulching
BMP C122	Nets and Blankets
BMP C123	Plastic Covering
BMP C140	Dust Control
BMP C150	Materials on Hand
BMP C151	Concrete Handling
BMP C152	Sawcutting and Surface Pollution Prevention
BMP C153	Material Delivery, Storage, and Containment
BMP C160	Certified Erosion and Sediment Control Lead
BMP C103	Interceptor Swale
BMP C207	Check Dams
BMP C220	Storm Drain Inlet Protection
BMP C233	Silt Fence
BMP C240	Sediment Trap

BMP C101: Preserving Natural Vegetation

Purpose

The purpose of preserving natural vegetation is to reduce erosion wherever practicable. Limiting site disturbance is the single most effective method for reducing erosion. For example, conifers can hold up to about 50 percent of all rain that falls during a storm. Up to 20-30 percent of this rain may never reach the ground but is taken up by the tree or evaporates. Another benefit is that the rain held in the tree can be released slowly to the ground after the storm.

Conditions of Use

Natural vegetation should be preserved on steep slopes, near perennial and intermittent water-courses or swales, and on building sites in wooded areas.

- As required by local governments.
- Phase construction to preserve natural vegetation on the project site for as long as possible during the construction period.

Design and Installation Specifications

Natural vegetation can be preserved in natural clumps or as individual trees, shrubs and vines.

The preservation of individual plants is more difficult because heavy equipment is generally used to remove unwanted vegetation. The points to remember when attempting to save individual plants are:

- Is the plant worth saving? Consider the location, species, size, age, vigor, and the work involved. Local governments may also have ordinances to save natural vegetation and trees.
- Fence or clearly mark areas around trees that are to be saved. It is preferable to keep ground disturbance away from the trees at least as far out as the dripline.

Plants need protection from three kinds of injuries:

- *Construction Equipment* - This injury can be above or below the ground level. Damage results from scarring, cutting of roots, and compaction of the soil. Placing a fenced buffer zone around plants to be saved prior to construction can prevent construction equipment injuries.
- *Grade Changes* - Changing the natural ground level will alter grades, which affects the plant's ability to obtain the necessary air, water, and minerals. Minor fills usually do not cause problems although sensitivity between species does vary and should be checked. Trees can typically tolerate fill of 6 inches or less. For shrubs and other plants, the fill should be less.

When there are major changes in grade, it may become necessary to supply air to the roots of plants. This can be done by placing a layer of gravel and a tile system over the roots before the fill is made. The tile system should be laid out on the original grade leading from a dry well

around the tree trunk. The system should then be covered with small stones to allow air to circulate over the root area.

Lowering the natural ground level can seriously damage trees and shrubs. The highest percentage of the plant roots are in the upper 12 inches of the soil and cuts of only 2-3 inches can cause serious injury. To protect the roots it may be necessary to terrace the immediate area around the plants to be saved. If roots are exposed, construction of retaining walls may be needed to keep the soil in place. Plants can also be preserved by leaving them on an undisturbed, gently sloping mound. To increase the chances for survival, it is best to limit grade changes and other soil disturbances to areas outside the dripline of the plant.

- *Excavations* - Protect trees and other plants when excavating for drainfields, power, water, and sewer lines. Where possible, the trenches should be routed around trees and large shrubs. When this is not possible, it is best to tunnel under them. This can be done with hand tools or with power augers. If it is not possible to route the trench around plants to be saved, then the following should be observed:
 - Cut as few roots as possible. When you have to cut, cut clean. Paint cut root ends with a wood dressing like asphalt base paint if roots will be exposed for more than 24-hours.
 - Backfill the trench as soon as possible.
 - Tunnel beneath root systems as close to the center of the main trunk to preserve most of the important feeder roots.

Some problems that can be encountered with a few specific trees are:

- Maple, Dogwood, Red alder, Western hemlock, Western red cedar, and Douglas fir do not readily adjust to changes in environment and special care should be taken to protect these trees.
- The windthrow hazard of Pacific silver fir and madrona is high, while that of Western hemlock is moderate. The danger of windthrow increases where dense stands have been thinned. Other species (unless they are on shallow, wet soils less than 20 inches deep) have a low windthrow hazard.
- Cottonwoods, maples, and willows have water-seeking roots. These can cause trouble in sewer lines and infiltration fields. On the other hand, they thrive in high moisture conditions that other trees would not.
- Thinning operations in pure or mixed stands of Grand fir, Pacific silver fir, Noble fir, Sitka spruce, Western red cedar, Western hemlock, Pacific dogwood, and Red alder can cause serious disease problems. Disease can become established through damaged limbs, trunks, roots, and freshly cut stumps. Diseased and weakened trees are also susceptible to insect attack.

Maintenance Standards

Inspect flagged and/or fenced areas regularly to make sure flagging or fencing has not been removed or damaged. If the flagging or fencing has been damaged or visibility reduced, it shall be repaired or replaced immediately and visibility restored.

If tree roots have been exposed or injured, “prune” cleanly with an appropriate pruning saw or loppers directly above the damaged roots and recover with native soils. Treatment of sap flowing trees (fir, hemlock, pine, soft maples) is not advised as sap forms a natural healing barrier.

BMP C102: Buffer Zones

Purpose

Creation of an undisturbed area or strip of natural vegetation or an established suitable planting that will provide a living filter to reduce soil erosion and stormwater runoff velocities.

Conditions of Use

Buffer zones are used along streams, wetlands and other bodies of water that need protection from erosion and sedimentation. Contractors can use vegetative buffer zone BMPs to protect natural swales and they can incorporate them into the natural landscaping of an area.

Do not use critical-areas buffer zones as sediment treatment areas. These areas shall remain completely undisturbed. The local permitting authority may expand the buffer widths temporarily to allow the use of the expanded area for removal of sediment.

The types of buffer zones can change the level of protection required as shown below:

Designated Critical Area Buffers - buffers that protect Critical Areas, as defined by the Washington State Growth Management Act, and are established and managed by the local permitting authority. These should not be disturbed and must be protected with sediment control BMPs to prevent impacts. The local permitting authority may expand the buffer widths temporarily to allow the use of the expanded area for removal of sediment.

Vegetative Buffer Zones - areas that may be identified in undisturbed vegetation areas or managed vegetation areas that are outside any Designated Critical Area Buffer. They may be utilized to provide an additional sediment control area and/or reduce runoff velocities. If being used for preservation of natural vegetation, they should be arranged in clumps or strips. They can be used to protect natural swales and incorporated into the natural landscaping area.

Design and Installation Specifications

- Preserving natural vegetation or plantings in clumps, blocks, or strips is generally the easiest and most successful method.
- Leave all unstable steep slopes in natural vegetation.
- Mark clearing limits and keep all equipment and construction debris out of the natural areas and buffer zones. Steel construction fencing is the most effective method to protect sensitive areas and buffers. Alternatively, wire-backed silt fence on steel posts is marginally effective. Flagging alone is typically not effective.
- Keep all excavations outside the dripline of trees and shrubs.
- Do not push debris or extra soil into the buffer zone area because it will cause damage by

burying and smothering vegetation.

- Vegetative buffer zones for streams, lakes or other waterways shall be established by the local permitting authority or other state or federal permits or approvals.

Maintenance Standards

Inspect the area frequently to make sure flagging remains in place and the area remains undisturbed. Replace all damaged flagging immediately. Remove all materials located in the buffer area that may impede the ability of the vegetation to act as a filter.

BMP C103: High-Visibility Fence

Purpose

High-visibility fencing is intended to:

- Restrict clearing to approved limits.
- Prevent disturbance of sensitive areas, their buffers, and other areas required to be left undisturbed.
- Limit construction traffic to designated construction entrances, exits, or internal roads.
- Protect areas where marking with survey tape may not provide adequate protection.

Conditions of Use

To establish clearing limits plastic, fabric, or metal fence may be used:

- At the boundary of sensitive areas, their buffers, and other areas required to be left uncleared.
- As necessary to control vehicle access to and on the site.

Design and Installation Specifications

High-visibility plastic fence shall be composed of a high-density polyethylene material and shall be at least four feet in height. Posts for the fencing shall be steel or wood and placed every 6 feet on center (maximum) or as needed to ensure rigidity. The fencing shall be fastened to the post every six inches with a polyethylene tie. On long continuous lengths of fencing, a tension wire or rope shall be used as a top stringer to prevent sagging between posts. The fence color shall be high-visibility orange. The fence tensile strength shall be 360 lbs/ft using the ASTM D4595 testing method.

If appropriate install fabric silt fence in accordance with [BMP C233: Silt Fence](#) to act as high-visibility fence. Silt fence shall be at least 3 feet high and must be highly visible to meet the requirements of this BMP.

Metal fences shall be designed and installed according to the manufacturer's specifications.

Metal fences shall be at least 3 feet high and must be highly visible.

Fences shall not be wired or stapled to trees.

Maintenance Standards

If the fence has been damaged or visibility reduced, it shall be repaired or replaced immediately and visibility restored.

BMP C105: Stabilized Construction Access

Purpose

Stabilized construction accesses are established to reduce the amount of sediment transported onto paved roads outside the project site by vehicles or equipment. This is done by constructing a stabilized pad of quarry spalls at entrances and exits for project sites.

Conditions of Use

Construction accesses shall be stabilized wherever traffic will be entering or leaving a construction site if paved roads or other paved areas are within 1,000 feet of the site.

For residential subdivision construction sites, provide a stabilized construction access for each residence, rather than only at the main subdivision entrance. Stabilized surfaces shall be of sufficient length/width to provide vehicle access/parking, based on lot size and configuration.

On large commercial, highway, and road projects, the designer should include enough extra materials in the contract to allow for additional stabilized accesses not shown in the initial Construction SWPPP. It is difficult to determine exactly where access to these projects will take place; additional materials will enable the contractor to install them where needed.

Design and Installation Specifications

See [Figure II-3.1: Stabilized Construction Access](#) for details. Note: the 100' minimum length of the access shall be reduced to the maximum practicable size when the size or configuration of the site does not allow the full length (100').

Construct stabilized construction accesses with a 12-inch thick pad of 4-inch to 8-inch quarry spalls, a 4-inch course of asphalt treated base (ATB), or use existing pavement. Do not use crushed concrete, cement, or calcium chloride for construction access stabilization because these products raise pH levels in stormwater and concrete discharge to waters of the State is prohibited.

A separation geotextile shall be placed under the spalls to prevent fine sediment from pumping up into the rock pad. The geotextile shall meet the standards listed in [Table II-3.2: Stabilized Construction Access Geotextile Standards](#).

Table II-3.2: Stabilized Construction Access Geotextile Standards

Geotextile Property	Required Value
Grab Tensile Strength (ASTM D4751)	200 psi min.

**Table II-3.2: Stabilized Construction Access
Geotextile Standards (continued)**

Geotextile Property	Required Value
Grab Tensile Elongation (ASTM D4632)	30% max.
Mullen Burst Strength (ASTM D3786-80a)	400 psi min.
AOS (ASTM D4751)	20-45 (U.S. standard sieve size)

- Consider early installation of the first lift of asphalt in areas that will be paved; this can be used as a stabilized access. Also consider the installation of excess concrete as a stabilized access. During large concrete pours, excess concrete is often available for this purpose.
- Fencing (see [BMP C 103: High-Visibility Fence](#)) shall be installed as necessary to restrict traffic to the construction access.
- Whenever possible, the access shall be constructed on a firm, compacted subgrade. This can substantially increase the effectiveness of the pad and reduce the need for maintenance.
- Construction accesses should avoid crossing existing sidewalks and back of walk drains if at all possible. If a construction access must cross a sidewalk or back of walk drain, the full length of the sidewalk and back of walk drain must be covered and protected from sediment leaving the site.

Alternative Material Specification

WSDOT has raised safety concerns about the Quarry Spall rock specified above. WSDOT observes that the 4-inch to 8-inch rock sizes can become trapped between Dually truck tires, and then released off-site at highway speeds. WSDOT has chosen to use a modified specification for the rock while continuously verifying that the Stabilized Construction Access remains effective. To remain effective, the BMP must prevent sediment from migrating off site. To date, there has been no performance testing to verify operation of this new specification. Jurisdictions may use the alternative specification, but must perform increased off-site inspection if they use, or allow others to use, it.

Stabilized Construction Accesses may use material that meets the requirements of WSDOT's *Standard Specifications for Road, Bridge, and Municipal Construction* Section 9-03.9(1) ([WSDOT, 2016](#)) for ballast except for the following special requirements.

The grading and quality requirements are listed in [Table II-3.3: Stabilized Construction Access Alternative Material Requirements](#).

**Table II-3.3: Stabilized
Construction Access
Alternative Material
Requirements**

Sieve Size	Percent Passing
2½"	99-100

**Table II-3.3: Stabilized
Construction Access
Alternative Material
Requirements
(continued)**

Sieve Size	Percent Passing
2"	65-100
¾"	40-80
No. 4	5 max.
No. 100	0-2
% Fracture	75 min.

- All percentages are by weight.
- The sand equivalent value and dust ratio requirements do not apply.
- The fracture requirement shall be at least one fractured face and will apply the combined aggregate retained on the No. 4 sieve in accordance with FOP for AASHTO T 335.

Maintenance Standards

Quarry spalls shall be added if the pad is no longer in accordance with the specifications.

- If the access is not preventing sediment from being tracked onto pavement, then alternative measures to keep the streets free of sediment shall be used. This may include replacement/cleaning of the existing quarry spalls, street sweeping, an increase in the dimensions of the access, or the installation of [BMP C106: Wheel Wash](#).
- Any sediment that is tracked onto pavement shall be removed by shoveling or street sweeping. The sediment collected by sweeping shall be removed or stabilized on site. The pavement shall not be cleaned by washing down the street, except when high efficiency sweeping is ineffective and there is a threat to public safety. If it is necessary to wash the streets, the construction of a small sump to contain the wash water shall be considered. The sediment would then be washed into the sump where it can be controlled.
- Perform street sweeping by hand or with a high efficiency sweeper. Do not use a non-high efficiency mechanical sweeper because this creates dust and throws soils into storm systems or conveyance ditches.
- Any quarry spalls that are loosened from the pad, which end up on the roadway shall be removed immediately.
- If vehicles are entering or exiting the site at points other than the construction access(es), [BMP C103: High-Visibility Fence](#) shall be installed to control traffic.

- Upon project completion and site stabilization, all construction accesses intended as permanent access for maintenance shall be permanently stabilized.

Figure II-3.1: Stabilized Construction Access

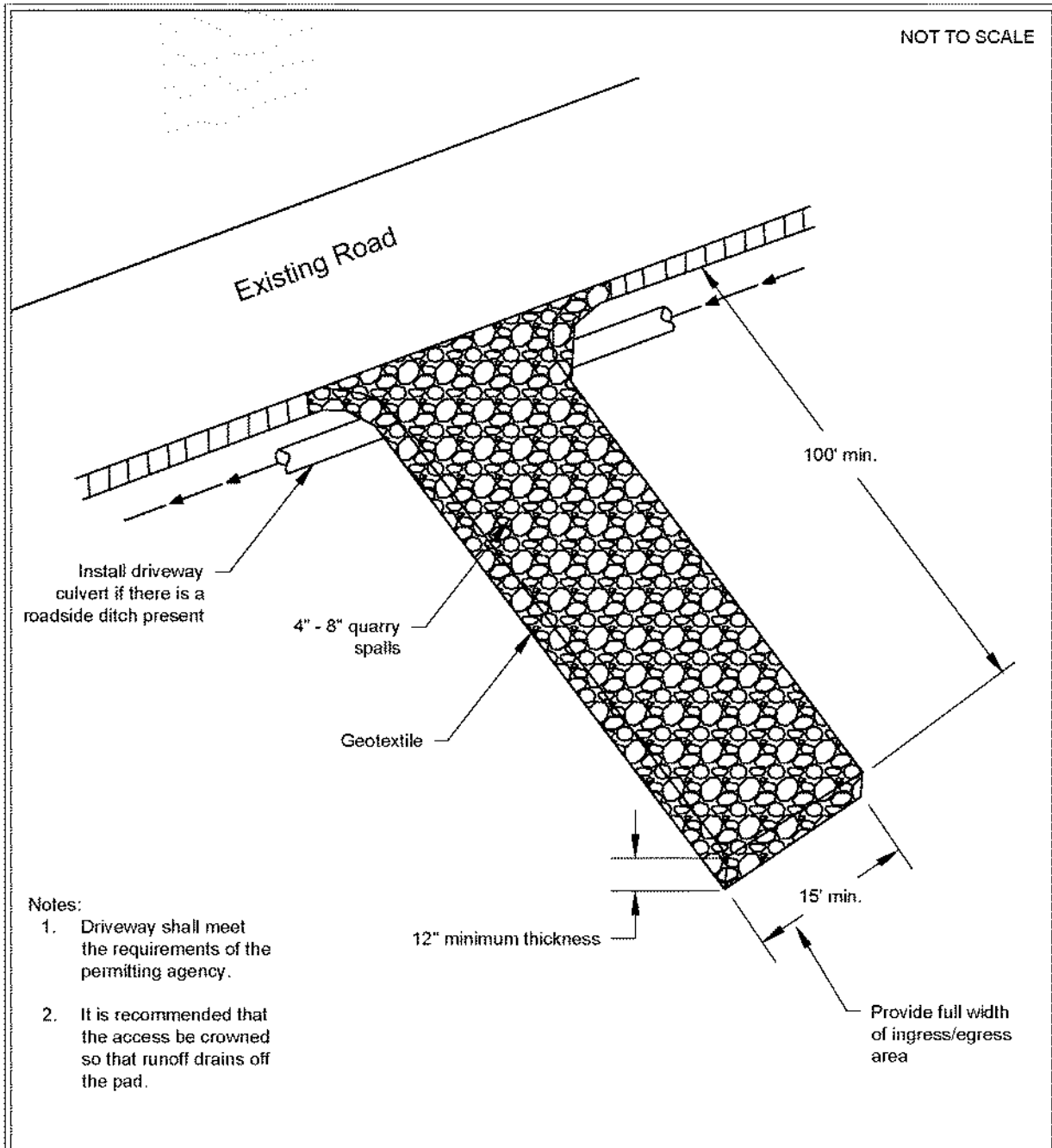

DEPARTMENT OF
ECOLOGY
State of Washington

Stabilized Construction Access

Revised June 2018

Please see <http://www.ecy.wa.gov/copyright.html> for copyright notice including permissions, limitation of liability, and disclaimer.

Approved as Functionally Equivalent

Ecology has approved products as able to meet the requirements of this BMP. The products did not pass through the Technology Assessment Protocol – Ecology (TAPE) process. Local jurisdictions may choose not to accept these products, or may require additional testing prior to consideration for local use. Products that Ecology has approved as functionally equivalent are available for review on Ecology’s website at:

<https://ecology.wa.gov/Regulations-Permits/Guidance-technical-assistance/Stormwater-permittee-guidance-resources/Emerging-stormwater-treatment-technologies>

BMP C106: Wheel Wash

Purpose

Wheel washes reduce the amount of sediment transported onto paved roads by washing dirt from the wheels of motor vehicles prior to the motor vehicles leaving the construction site.

Conditions of Use

- Use a wheel wash when [BMP C 105: Stabilized Construction Access](#) is not preventing sediment from being tracked off site.
- Wheel washing is generally an effective BMP when installed with careful attention to topography. For example, a wheel wash can be detrimental if installed at the top of a slope abutting a right-of-way where the water from the dripping truck can run unimpeded into the street.
- Pressure washing combined with an adequately sized and surfaced pad with direct drainage to a large 10-foot x 10-foot sump can be very effective.
- Wheel wash wastewater is not stormwater. It is commonly called process water, and must be discharged to a separate on-site treatment system that prevents discharge to waters of the State, or to the sanitary sewer with local sewer district approval.
- Wheel washes may use closed-loop recirculation systems to conserve water use.
- Wheel wash wastewater shall not include wastewater from concrete washout areas.
- When practical, the wheel wash should be placed in sequence with [BMP C 105: Stabilized Construction Access](#). Locate the wheel wash such that vehicles exiting the wheel wash will enter directly onto [BMP C 105: Stabilized Construction Access](#). In order to achieve this, [BMP C 105: Stabilized Construction Access](#) may need to be extended beyond the standard installation to meet the exit of the wheel wash.

Design and Installation Specifications

Suggested details are shown in [Figure II-3.2: Wheel Wash](#). The Local Permitting Authority may allow other designs. A minimum of 6 inches of asphalt treated base (ATB) over crushed base material or 8 inches over a good subgrade is recommended to pave the wheel wash.

Use a low clearance truck to test the wheel wash before paving. Either a belly dump or lowboy will work well to test clearance.

Keep the water level from 12 to 14 inches deep to avoid damage to truck hubs and filling the truck tongues with water.

Midpoint spray nozzles are only needed in extremely muddy conditions.

Wheel wash systems should be designed with a small grade change, 6- to 12-inches for a 10-foot-wide pond, to allow sediment to flow to the low side of pond to help prevent re-suspension of sediment. A drainpipe with a 2- to 3-foot riser should be installed on the low side of the pond to allow for easy cleaning and refilling. Polymers may be used to promote coagulation and flocculation in a closed-loop system. Polyacrylamide (PAM) added to the wheel wash water at a rate of 0.25 - 0.5 pounds per 1,000 gallons of water increases effectiveness and reduces cleanup time. If PAM is already being used for dust or erosion control and is being applied by a water truck, the same truck can be used to change the wash water.

Maintenance Standards

The wheel wash should start out each day with fresh water.

The wheel wash water should be changed a minimum of once per day. On large earthwork jobs where more than 10-20 trucks per hour are expected, the wheel wash water will need to be changed more often.

Approved as Functionally Equivalent

Ecology has approved products as able to meet the requirements of this BMP. The products did not pass through the Technology Assessment Protocol – Ecology (TAPE) process. Local jurisdictions may choose not to accept these products, or may require additional testing prior to consideration for local use. Products that Ecology has approved as functionally equivalent are available for review on Ecology's website at:

<https://ecology.wa.gov/Regulations-Permits/Guidance-technical-assistance/Stormwater-permittee-guidance-resources/Emerging-stormwater-treatment-technologies>

Figure II-3.2: Wheel Wash

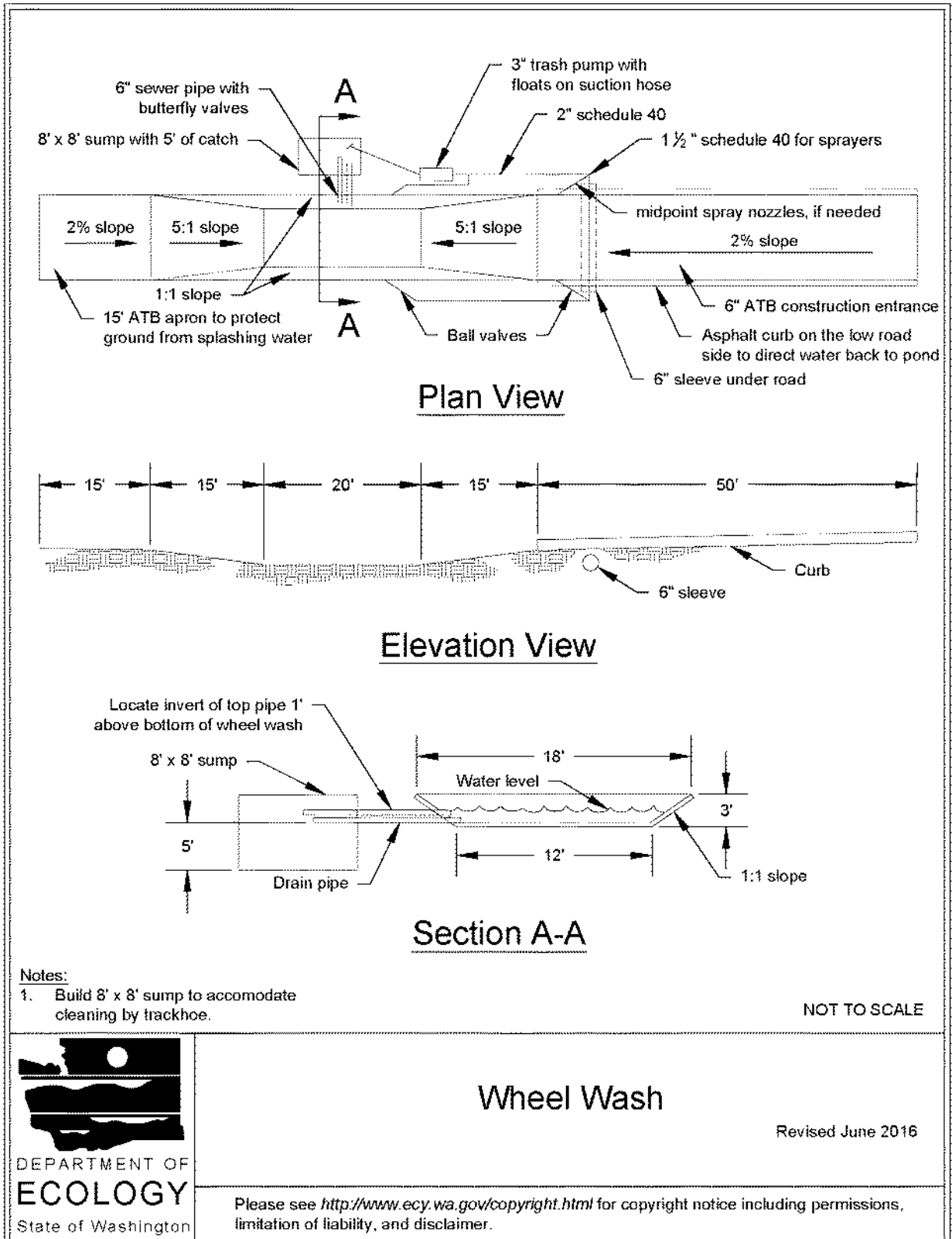

BMP C107: Construction Road / Parking Area Stabilization

Purpose

Stabilizing roads, parking areas, and other on-site vehicle transportation routes immediately after grading reduces erosion caused by construction traffic or stormwater runoff.

Conditions of Use

Roads and parking areas shall be stabilized wherever they are constructed, whether permanent or temporary, for use by construction traffic.

[BMP C103: High-Visibility Fence](#) shall be installed, if necessary, to limit the access of vehicles to only those roads and parking areas that are stabilized.

Design and Installation Specifications

- On areas that will receive asphalt as part of the project, install the first lift as soon as possible.
- A 6-inch depth of 2- to 4-inch crushed rock, gravel base, or crushed surfacing base course shall be applied immediately after grading or utility installation. A 4-inch course of asphalt treated base (ATB) may also be used, or the road/parking area may be paved. It may also be possible to use cement or calcium chloride for soil stabilization. If cement or cement kiln dust is used for roadbase stabilization, pH monitoring and [BMP C252: Treating and Disposing of High pH Water](#) is necessary to evaluate and minimize the effects on stormwater. If the area will not be used for permanent roads, parking areas, or structures, a 6-inch depth of hog fuel may also be used, but this is likely to require more maintenance. Whenever possible, construction roads and parking areas shall be placed on a firm, compacted subgrade.
- Temporary road gradients shall not exceed 15 percent. Roadways shall be carefully graded to drain. Drainage ditches shall be provided on each side of the roadway in the case of a crowned section, or on one side in the case of a super-elevated section. Drainage ditches shall be directed to a sediment control BMP.
- Rather than relying on ditches, it may also be possible to grade the road so that runoff sheetflows into a heavily vegetated area with a well-developed topsoil. Landscaped areas are not adequate. If this area has at least 50 feet of vegetation that water can flow through, then it is generally preferable to use the vegetation to treat runoff, rather than a sediment pond or trap. The 50 feet shall not include wetlands or their buffers. If runoff is allowed to sheetflow through adjacent vegetated areas, it is vital to design the roadways and parking areas so that no concentrated runoff is created.
- Storm drain inlets shall be protected to prevent sediment-laden water entering the drainage system (see [BMP C220: Inlet Protection](#)).

Maintenance Standards

Inspect stabilized areas regularly, especially after large storm events.

Crushed rock, gravel base, etc., shall be added as required to maintain a stable driving surface and to stabilize any areas that have eroded.

Following construction, these areas shall be restored to pre-construction condition or better to prevent future erosion.

Perform street cleaning at the end of each day or more often if necessary.

BMP C120: Temporary and Permanent Seeding

Purpose

Seeding reduces erosion by stabilizing exposed soils. A well-established vegetative cover is one of the most effective methods of reducing erosion.

Conditions of Use

Use seeding throughout the project on disturbed areas that have reached final grade or that will remain unworked for more than 30 days.

The optimum seeding windows for western Washington are April 1 through June 30 and September 1 through October 1.

Between July 1 and August 30 seeding requires irrigation until 75 percent grass cover is established.

Between October 1 and March 30 seeding requires a cover of mulch or an erosion control blanket until 75 percent grass cover is established.

Review all disturbed areas in late August to early September and complete all seeding by the end of September. Otherwise, vegetation will not establish itself enough to provide more than average protection.

Mulch is required at all times for seeding because it protects seeds from heat, moisture loss, and transport due to runoff. Mulch can be applied on top of the seed or simultaneously by hydroseeding. See [BMP C121: Mulching](#) for specifications.

Seed and mulch all disturbed areas not otherwise vegetated at final site stabilization. Final stabilization means the completion of all soil disturbing activities at the site and the establishment of a permanent vegetative cover, or equivalent permanent stabilization measures (such as pavement, riprap, gabions, or geotextiles) which will prevent erosion. See [BMP T5.13: Post-Construction Soil Quality and Depth](#).

Design and Installation Specifications

General

- Install channels intended for vegetation before starting major earthwork and hydroseed with a Bonded Fiber Matrix. For vegetated channels that will have high flows, install erosion control blankets over the top of hydroseed. Before allowing water to flow in vegetated channels, establish 75 percent vegetation cover. If vegetated channels cannot be established by seed

before water flow; install sod in the channel bottom — over top of hydromulch and erosion control blankets.

- Confirm the installation of all required surface water control measures to prevent seed from washing away.
- Hydroseed applications shall include a minimum of 1,500 pounds per acre of mulch with 3 percent tackifier. See [BMP C121: Mulching](#) for specifications.
- Areas that will have seeding only and not landscaping may need compost or meal-based mulch included in the hydroseed in order to establish vegetation. Re-install native topsoil on the disturbed soil surface before application. See [BMP T5.13: Post-Construction Soil Quality and Depth](#).
- When installing seed via hydroseeding operations, only about 1/3 of the seed actually ends up in contact with the soil surface. This reduces the ability to establish a good stand of grass quickly. To overcome this, consider increasing seed quantities by up to 50 percent.
- Enhance vegetation establishment by dividing the hydromulch operation into two phases:
 - Phase 1- Install all seed and fertilizer with 25-30 percent mulch and tackifier onto soil in the first lift.
 - Phase 2- Install the rest of the mulch and tackifier over the first lift.

Or, enhance vegetation by:

- Installing the mulch, seed, fertilizer, and tackifier in one lift.
- Spread or blow straw over the top of the hydromulch at a rate of 800-1000 pounds per acre.
- Hold straw in place with a standard tackifier.

Both of these approaches will increase cost moderately but will greatly improve and enhance vegetative establishment. The increased cost may be offset by the reduced need for:

- Irrigation.
- Reapplication of mulch.
- Repair of failed slope surfaces.

This technique works with standard hydromulch (1,500 pounds per acre minimum) and Bonded Fiber Matrix/ Mechanically Bonded Fiber Matrix (BFM/MBFMs) (3,000 pounds per acre minimum).

- Seed may be installed by hand if:
 - Temporary and covered by straw, mulch, or topsoil.
 - Permanent in small areas (usually less than 1 acre) and covered with mulch, topsoil, or erosion blankets.
- The seed mixes listed in [Table II-3.4: Temporary and Permanent Seed Mixes](#) include

recommended mixes for both temporary and permanent seeding.

- Apply these mixes, with the exception of the wet area seed mix, at a rate of 120 pounds per acre. This rate can be reduced if soil amendments or slow-release fertilizers are used. Apply the wet area seed mix at a rate of 60 pounds per acre.
- Consult the local suppliers or the local conservation district for their recommendations. The appropriate mix depends on a variety of factors, including location, exposure, soil type, slope, and expected foot traffic. Alternative seed mixes approved by the local authority may be used, depending on the soil type and hydrology of the area.

Table II-3.4: Temporary and Permanent Seed Mixes

Common Name	Latin Name	% Weight	% Purity	% Germination
Temporary Erosion Control Seed Mix				
A standard mix for areas requiring a temporary vegetative cover.				
Chewings or annual blue grass	<i>Festuca rubra var. commutata</i> or <i>Poa annua</i>	40	98	90
Perennial rye	<i>Lolium perenne</i>	50	98	90
Redtop or colonial bentgrass	<i>Agrostis alba</i> or <i>Agrostis tenuis</i>	5	92	85
White dutch clover	<i>Trifolium repens</i>	5	98	90
Landscaping Seed Mix				
A recommended mix for landscaping seed.				
Perennial rye blend	<i>Lolium perenne</i>	70	98	90
Chewings and red fescue blend	<i>Festuca rubra var. commutata</i> or <i>Festuca rubra</i>	30	98	90
Low-Growing Turf Seed Mix				
A turf seed mix for dry situations where there is no need for watering. This mix requires very little maintenance.				
Dwarf tall fescue (several varieties)	<i>Festuca arundinacea var.</i>	45	98	90
Dwarf perennial rye (Barclay)	<i>Lolium perenne var. barclay</i>	30	98	90
Red fescue	<i>Festuca rubra</i>	20	98	90
Colonial bentgrass	<i>Agrostis tenuis</i>	5	98	90
Bioswale Seed Mix				
A seed mix for bioswales and other intermittently wet areas.				
Tall or meadow fes-	<i>Festuca arundin-</i>	75-80	98	90

Table II-3.4: Temporary and Permanent Seed Mixes (continued)

Common Name	Latin Name	% Weight	% Purity	% Germination
cue	<i>acea</i> or <i>Festuca elatior</i>			
Seaside/Creeping bentgrass	<i>Agrostis palustris</i>	10-15	92	85
Redtop bentgrass	<i>Agrostis alba</i> or <i>Agrostis gigantea</i>	5-10	90	80
Wet Area Seed Mix				
A low-growing, relatively non-invasive seed mix appropriate for very wet areas that are not regulated wetlands. Consult Hydraulic Permit Authority (HPA) for seed mixes if applicable.				
Tall or meadow fescue	<i>Festuca arundinacea</i> or <i>Festuca elatior</i>	60-70	98	90
Seaside/Creeping bentgrass	<i>Agrostis palustris</i>	10-15	98	85
Meadow foxtail	<i>Alepocurus pratensis</i>	10-15	90	80
Alsike clover	<i>Trifolium hybridum</i>	1-6	98	90
Redtop bentgrass	<i>Agrostis alba</i>	1-6	92	85
Meadow Seed Mix				
A recommended meadow seed mix for infrequently maintained areas or non-maintained areas where colonization by native plants is desirable. Likely applications include rural road and utility right-of-way. Seeding should take place in September or very early October in order to obtain adequate establishment prior to the winter months. Consider the appropriateness of clover, a fairly invasive species, in the mix. Amending the soil can reduce the need for clover.				
Redtop or Oregon bentgrass	<i>Agrostis alba</i> or <i>Agrostis oregonensis</i>	20	92	85
Red fescue	<i>Festuca rubra</i>	70	98	90
White dutch clover	<i>Trifolium repens</i>	10	98	90

Roughening and Rototilling

- The seedbed should be firm and rough. Roughen all soil no matter what the slope. Track walk slopes before seeding if engineering purposes require compaction. Backblading or smoothing of slopes greater than 4H:1V is not allowed if they are to be seeded.
- Restoration-based landscape practices require deeper incorporation than that provided by a simple single-pass rototilling treatment. Wherever practical, initially rip the subgrade to improve long-term permeability, infiltration, and water inflow qualities. At a minimum,

permanent areas shall use soil amendments to achieve organic matter and permeability performance defined in engineered soil/landscape systems. For systems that are deeper than 8 inches complete the rototilling process in multiple lifts, or prepare the engineered soil system per specifications and place to achieve the specified depth.

Fertilizers

- Conducting soil tests to determine the exact type and quantity of fertilizer is recommended. This will prevent the over-application of fertilizer.
- Organic matter is the most appropriate form of fertilizer because it provides nutrients (including nitrogen, phosphorus, and potassium) in the least water-soluble form.
- In general, use 10-4-6 N-P-K (nitrogen-phosphorus-potassium) fertilizer at a rate of 90 pounds per acre. Always use slow-release fertilizers because they are more efficient and have fewer environmental impacts. Do not add fertilizer to the hydromulch machine, or agitate, more than 20 minutes before use. Too much agitation destroys the slow-release coating.
- There are numerous products available that take the place of chemical fertilizers. These include several with seaweed extracts that are beneficial to soil microbes and organisms. If 100 percent cottonseed meal is used as the mulch in hydroseed, chemical fertilizer may not be necessary. Cottonseed meal provides a good source of long-term, slow-release, available nitrogen.

Bonded Fiber Matrix and Mechanically Bonded Fiber Matrix

- On steep slopes use Bonded Fiber Matrix (BFM) or Mechanically Bonded Fiber Matrix (MBFM) products. Apply BFM/MBFM products at a minimum rate of 3,000 pounds per acre with approximately 10 percent tackifier. Achieve a minimum of 95 percent soil coverage during application. Numerous products are available commercially. Most products require 24-36 hours to cure before rainfall and cannot be installed on wet or saturated soils. Generally, products come in 40-50 pound bags and include all necessary ingredients except for seed and fertilizer.
- Install products per manufacturer's instructions.
- BFMs and MBFMs provide good alternatives to blankets in most areas requiring vegetation establishment. Advantages over blankets include:
 - BFM and MBFMs do not require surface preparation.
 - Helicopters can assist in installing BFM and MBFMs in remote areas.
 - On slopes steeper than 2.5H:1V, blanket installers may require ropes and harnesses for safety.
 - Installing BFM and MBFMs can save at least \$1,000 per acre compared to blankets.

Maintenance Standards

Reseed any seeded areas that fail to establish at least 75 percent cover (100 percent cover for areas that receive sheet or concentrated flows). If reseeding is ineffective, use an alternate method such as sodding, mulching, nets, or blankets.

- Reseed and protect by mulch any areas that experience erosion after achieving adequate cover. Reseed and protect by mulch any eroded area.
- Supply seeded areas with adequate moisture, but do not water to the extent that it causes run-off.

Approved as Functionally Equivalent

Ecology has approved products as able to meet the requirements of this BMP. The products did not pass through the Technology Assessment Protocol – Ecology (TAPE) process. Local jurisdictions may choose not to accept these products, or may require additional testing prior to consideration for local use. Products that Ecology has approved as functionally equivalent are available for review on Ecology’s website at:

<https://ecology.wa.gov/Regulations-Permits/Guidance-technical-assistance/Stormwater-permittee-guidance-resources/Emerging-stormwater-treatment-technologies>

BMP C121: Mulching

Purpose

Mulching soils provides immediate temporary protection from erosion. Mulch also enhances plant establishment by conserving moisture, holding fertilizer, seed, and topsoil in place, and moderating soil temperatures. There are a variety of mulches that can be used. This section discusses only the most common types of mulch.

Conditions of Use

As a temporary cover measure, mulch should be used:

- For less than 30 days on disturbed areas that require cover.
- At all times for seeded areas, especially during the wet season and during the hot summer months.
- During the wet season on slopes steeper than 3H:1V with more than 10 feet of vertical relief.

Mulch may be applied at any time of the year and must be refreshed periodically.

For seeded areas, mulch may be made up of 100 percent:

- cottonseed meal;
- fibers made of wood, recycled cellulose, hemp, or kenaf;

- compost;
- or blends of these.

Tackifier shall be plant-based, such as guar or alpha plantago, or chemical-based such as polyacrylamide or polymers.

Generally, mulches come in 40-50 pound bags. Seed and fertilizer are added at time of application.

Recycled cellulose may contain polychlorinated biphenyl (PCBs). Ecology recommends that products should be evaluated for PCBs prior to use.

Refer to [BMP C126: Polyacrylamide \(PAM\) for Soil Erosion Protection](#) for conditions of use. PAM shall not be directly applied to water or allowed to enter a water body.

Any mulch or tackifier product used shall be installed per the manufacturer’s instructions.

Design and Installation Specifications

For mulch materials, application rates, and specifications, see [Table II-3.6: Mulch Standards and Guidelines](#). Consult with the local supplier or the local conservation district for their recommendations. Increase the application rate until the ground is 95% covered (i.e. not visible under the mulch layer). Note: Thickness may be increased for disturbed areas in or near sensitive areas or other areas highly susceptible to erosion.

Where the option of “Compost” is selected, it should be a coarse compost that meets the size gradations listed in [Table II-3.5: Size Gradations of Compost as Mulch Material](#) when tested in accordance with Test Method 02.02-B found in *Test Methods for the Examination of Composting and Compost* (Thompson, 2001).

Table II-3.5: Size Gradations of Compost as Mulch Material

Sieve Size	Percent Passing
3"	100%
1"	90% - 100%
3/4"	70% - 100%
1/4"	40% - 100%

Mulch used within the ordinary high-water mark of surface waters should be selected to minimize potential flotation of organic matter. Composted organic materials have higher specific gravities (densities) than straw, wood, or chipped material. Consult the Hydraulic Permit Authority (HPA) for mulch mixes if applicable.

Maintenance Standards

The thickness of the mulch cover must be maintained.

Any areas that experience erosion shall be remulched and/or protected with a net or blanket. If the erosion problem is drainage related, then the problem shall be fixed and the eroded area remulched.

Table II-3.6: Mulch Standards and Guidelines

Mulch Material	Guideline	Description
Straw	Quality Standards	Air-dried; free from undesirable seed and coarse material.
	Application Rates	2"-3" thick; 5 bales per 1,000 sf or 2-3 tons per acre
	Remarks	Cost-effective protection when applied with adequate thickness. Hand-application generally requires greater thickness than blown straw. The thickness of straw may be reduced by half when used in conjunction with seeding. In windy areas straw must be held in place by crimping, using a tackifier, or covering with netting. Blown straw always has to be held in place with a tackifier as even light winds will blow it away. Straw, however, has several deficiencies that should be considered when selecting mulch materials. It often introduces and/or encourages the propagation of weed species and it has no significant long-term benefits. It should also not be used within the ordinary high-water elevation of surface waters (due to flotation).
Hydromulch	Quality Standards	No growth inhibiting factors.
	Application Rates	Approx. 35-45 lbs per 1,000 sf or 1,500 - 2,000 lbs per acre
	Remarks	Shall be applied with hydromulcher. Shall not be used without seed and tackifier unless the application rate is at least doubled. Fibers longer than about 3/4 - 1 inch clog hydromulch equipment. Fibers should be kept to less than 3/4 inch.
Compost	Quality Standards	No visible water or dust during handling. Must be produced per WAC 173-350 , Solid Waste Handling Standards, but may have up to 35% biosolids.
	Application Rates	2" thick min.; approx. 100 tons per acre (approx. 750 lbs per cubic yard)
	Remarks	More effective control can be obtained by increasing thickness to 3". Excellent mulch for protecting final grades until landscaping because it can be directly seeded or tilled into soil as an amendment. Compost used for mulch has a coarser size gradation than compost used for BMP C125: Topsoiling / Composting or BMP T5.13: Post-Construction Soil Quality and Depth . It is more stable and practical to use in wet areas and during rainy weather conditions. Do not use near wetlands or near phosphorous impaired water bodies.
Chipped Site Vegetation	Quality Standards	Gradations from fines to 6 inches in length for texture, variation, and interlocking properties. Include a mix of various sizes so that the average size is between 2- and 4- inches.
	Application Rates	2" thick min.;

Table II-3.6: Mulch Standards and Guidelines (continued)

Mulch Material	Guideline	Description
	Remarks	<p>This is a cost-effective way to dispose of debris from clearing and grubbing, and it eliminates the problems associated with burning. Generally, it should not be used on slopes above approx. 10% because of its tendency to be transported by runoff. It is not recommended within 200 feet of surface waters. If permanent seeding or planting is expected shortly after mulch, the decomposition of the chipped vegetation may tie up nutrients important to grass establishment.</p> <p>Note: thick application of this material over existing grass, herbaceous species, and some groundcovers could smother and kill vegetation.</p>
Wood-Based Mulch	Quality Standards	No visible water or dust during handling. Must be purchased from a supplier with a Solid Waste Handling Permit or one exempt from solid waste regulations.
	Application Rates	2" thick min.; approx. 100 tons per acre (approx. 750 lbs. per cubic yard)
	Remarks	This material is often called "wood straw" or "hog fuel". The use of mulch ultimately improves the organic matter in the soil. Special caution is advised regarding the source and composition of wood-based mulches. Its preparation typically does not provide any weed seed control, so evidence of residual vegetation in its composition or known inclusion of weed plants or seeds should be monitored and prevented (or minimized).
Wood Strand Mulch	Quality Standards	A blend of loose, long, thin wood pieces derived from native conifer or deciduous trees with high length-to-width ratio.
	Application Rates	2" thick min.
	Remarks	Cost-effective protection when applied with adequate thickness. A minimum of 95-percent of the wood strand shall have lengths between 2 and 10-inches, with a width and thickness between 1/16 and 1/2-inches. The mulch shall not contain resin, tannin, or other compounds in quantities that would be detrimental to plant life. Sawdust or wood shavings shall not be used as mulch. [Specification 9-14.4(4) from the <i>Standard Specifications for Road, Bridge, and Municipal Construction</i> (WSDOT, 2016)

BMP C122: Nets and Blankets

Purpose

Erosion control nets and blankets are intended to prevent erosion and hold seed and mulch in place on steep slopes and in channels so that vegetation can become well established. In addition, some nets and blankets can be used to permanently reinforce turf to protect drainage ways during high flows.

Nets (commonly called matting) are strands of material woven into an open, but high-tensile strength net (for example, coconut fiber matting). Blankets are strands of material that are not tightly woven, but instead form a layer of interlocking fibers, typically held together by a biodegradable or photodegradable netting (for example, excelsior or straw blankets). They generally have lower tensile strength than nets, but cover the ground more completely. Coir (coconut fiber) fabric comes as both nets and blankets.

Conditions of Use

Erosion control netting and blankets shall be made of natural plant fibers unaltered by synthetic materials.

Erosion control nets and blankets should be used:

- To aid permanent vegetated stabilization of slopes 2H:1V or greater and with more than 10 feet of vertical relief.
- For drainage ditches and swales (highly recommended). The application of appropriate netting or blanket to drainage ditches and swales can protect bare soil from channelized runoff while vegetation is established. Nets and blankets also can capture a great deal of sediment due to their open, porous structure. Nets and blankets can be used to permanently stabilize channels and may provide a cost-effective, environmentally preferable alternative to riprap.

Disadvantages of nets and blankets include:

- Surface preparation is required.
- On slopes steeper than 2.5H:1V, net and blanket installers may need to be roped and harnessed for safety.
- They cost at least \$4,000-6,000 per acre installed.

Advantages of nets and blankets include:

- Installation without mobilizing special equipment.
- Installation by anyone with minimal training
- Installation in stages or phases as the project progresses.
- Installers can hand place seed and fertilizer as they progress down the slope.
- Installation in any weather.
- There are numerous types of nets and blankets that can be designed with various parameters in mind. Those parameters include: fiber blend, mesh strength, longevity, biodegradability, cost, and availability.

An alternative to nets and blankets in some limited conditions is [BMP C202: Riprap Channel Lining](#). Ensure that [BMP C202: Riprap Channel Lining](#) is appropriate before using it as a substitute for nets and blankets.

Design and Installation Specifications

- See [Figure II-3.3: Channel Installation \(Clackamas County et al., 2008\)](#) and [Figure II-3.4: Slope Installation](#) for typical orientation and installation of nets and blankets used in channels and as slope protection. Note: these are typical only; all nets and blankets must be installed per manufacturer's installation instructions.
- Installation is critical to the effectiveness of these products. If good ground contact is not achieved, runoff can concentrate under the product, resulting in significant erosion.
- Installation of nets and blankets on slopes:
 1. Complete final grade and track walk up and down the slope.
 2. Install hydromulch with seed and fertilizer.
 3. Dig a small trench, approximately 12 inches wide by 6 inches deep along the top of the slope.
 4. Install the leading edge of the net/blanket into the small trench and staple approximately every 18 inches. NOTE: Staples are metal, "U"-shaped, and a minimum of 6 inches long. Longer staples are used in sandy soils. Biodegradable stakes are also available.
 5. Roll the net/blanket slowly down the slope as the installer walks backward. NOTE: The net/blanket rests against the installer's legs. Staples are installed as the net/blanket is unrolled. It is critical that the proper staple pattern is used for the net/blanket being installed. The net/blanket is not to be allowed to roll down the slope on its own as this stretches the net/blanket, making it impossible to maintain soil contact. In addition, no one is allowed to walk on the net/blanket after it is in place.
 6. If the net/blanket is not long enough to cover the entire slope length, the trailing edge of the upper net/blanket should overlap the leading edge of the lower net/blanket and be stapled. On steeper slopes, this overlap should be installed in a small trench, stapled, and covered with soil.
- With the variety of products available, it is impossible to cover all the details of appropriate use and installation. Therefore, it is critical that the designer consult the manufacturer's information and that a site visit takes place in order to ensure that the product specified is appropriate. Information is also available in WSDOT's *Standard Specifications for Road, Bridge, and Municipal Construction* Division 8-01 and Division 9-14 ([WSDOT, 2016](#)).
- Use jute matting in conjunction with mulch ([BMP C121: Mulching](#)). Excelsior, woven straw blankets and coir (coconut fiber) blankets may be installed without mulch. There are many other types of erosion control nets and blankets on the market that may be appropriate in certain circumstances.
- In general, most nets (e.g., jute matting) require mulch in order to prevent erosion because they have a fairly open structure. Blankets typically do not require mulch because they usually provide complete protection of the surface.
- Extremely steep, unstable, wet, or rocky slopes are often appropriate candidates for use of synthetic blankets, as are riverbanks, beaches and other high-energy environments. If

synthetic blankets are used, the soil should be hydromulched first.

- 100-percent biodegradable blankets are available for use in sensitive areas. These organic blankets are usually held together with a paper or fiber mesh and stitching which may last up to a year.
- Most netting used with blankets is photodegradable, meaning it breaks down under sunlight (not UV stabilized). However, this process can take months or years even under bright sun. Once vegetation is established, sunlight does not reach the mesh. It is not uncommon to find non-degraded netting still in place several years after installation. This can be a problem if maintenance requires the use of mowers or ditch cleaning equipment. In addition, birds and small animals can become trapped in the netting.

Maintenance Standards

- Maintain good contact with the ground. Erosion must not occur beneath the net or blanket.
- Repair and staple any areas of the net or blanket that are damaged or not in close contact with the ground.
- Fix and protect eroded areas if erosion occurs due to poorly controlled drainage.

Figure II-3.3: Channel Installation

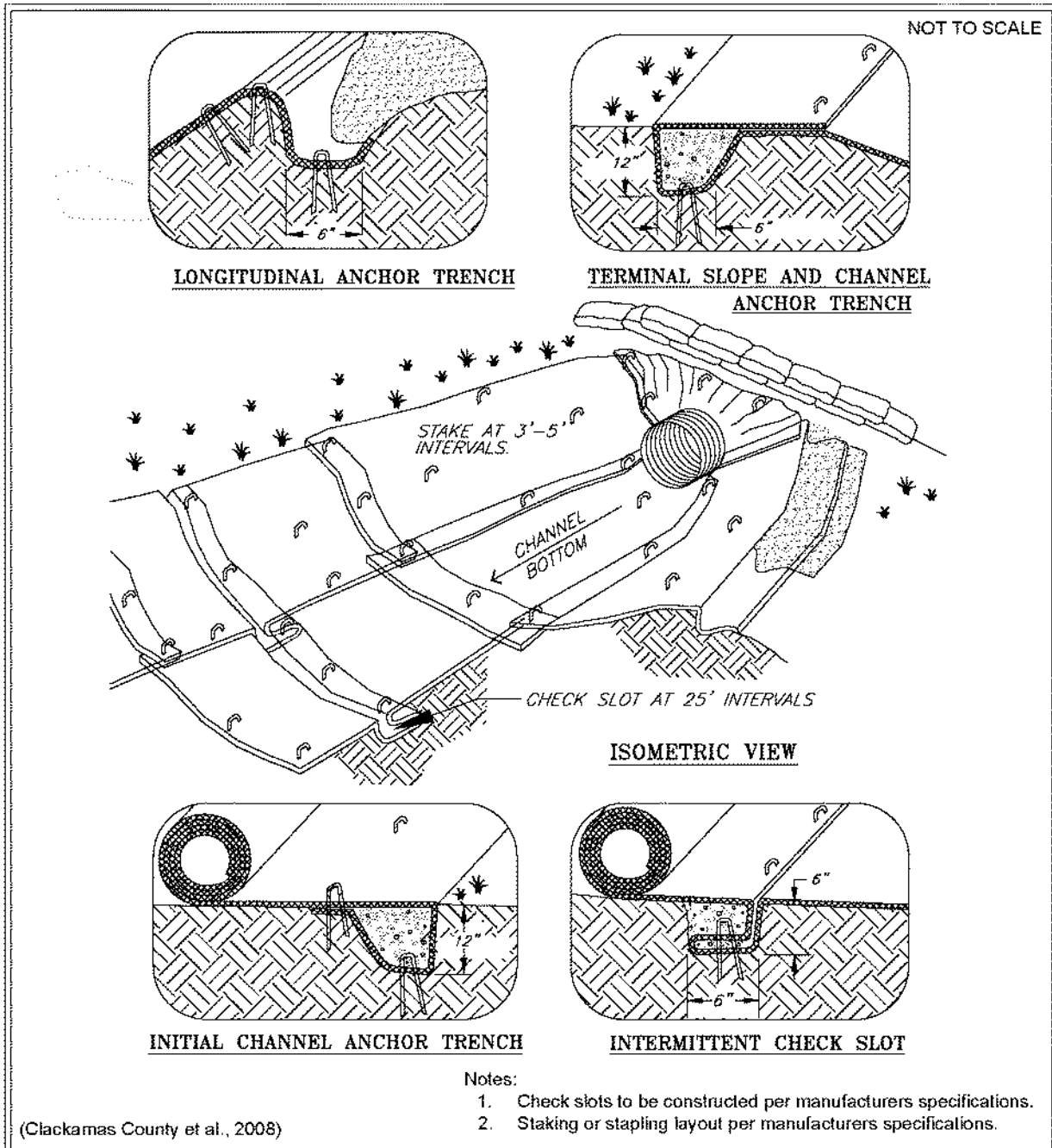

Channel Installation

Revised July 2016

Please see <http://www.ecy.wa.gov/copyright.html> for copyright notice including permissions, limitation of liability, and disclaimer.

Figure II-3.4: Slope Installation

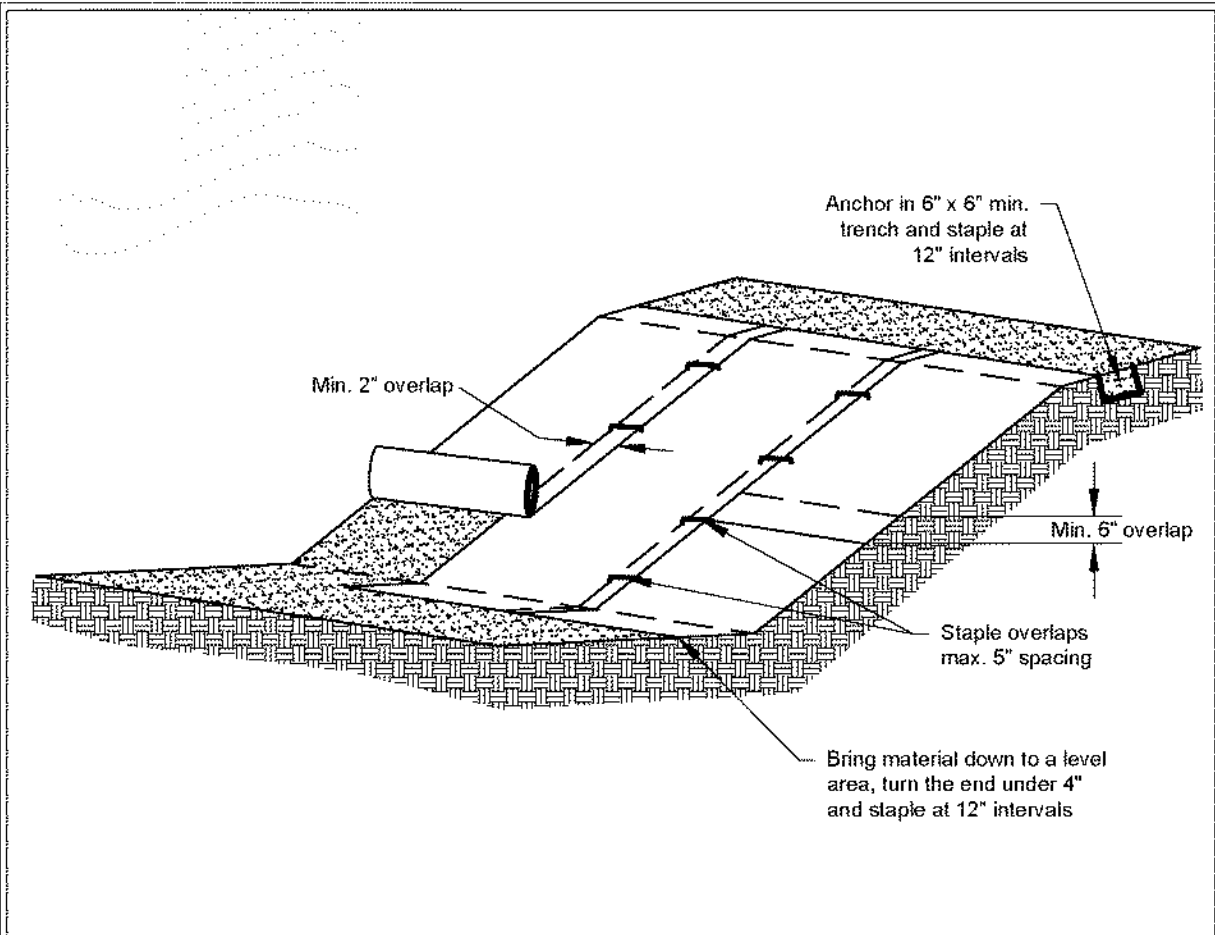

Notes:

1. Slope surface shall be smooth before placement for proper soil contact.
2. Stapling pattern as per manufacturer's recommendations.
3. Do not stretch blankets/matlings tight - allow the rolls to mold to any irregularities.
4. For slopes less than 3H:1V, rolls may be placed in horizontal strips.
5. If there is a berm at the top of the slope, anchor upslope of the berm.
6. Lime, fertilize, and seed before installation. Planting of shrubs, trees, etc. should occur after installation.

NOT TO SCALE



Slope Installation

Revised June 2016

Please see <http://www.ecy.wa.gov/copyright.html> for copyright notice including permissions, limitation of liability, and disclaimer.

BMP C123: Plastic Covering

Purpose

Plastic covering provides immediate, short-term erosion protection to slopes and disturbed areas.

Conditions of Use

Plastic covering may be used on disturbed areas that require cover measures for less than 30 days, except as stated below.

- Plastic is particularly useful for protecting cut and fill slopes and stockpiles. However, the relatively rapid breakdown of most polyethylene sheeting makes it unsuitable for applications greater than six months.
- Due to rapid runoff caused by plastic covering, do not use this method upslope of areas that might be adversely impacted by concentrated runoff. Such areas include steep and/or unstable slopes.
- Plastic sheeting may result in increased runoff volumes and velocities, requiring additional on-site measures to counteract the increases. Creating a trough with wattles or other material can convey clean water away from these areas.
- To prevent undercutting, trench and backfill rolled plastic covering products.
- Although the plastic material is inexpensive to purchase, the cost of installation, maintenance, removal, and disposal add to the total costs of this BMP.
- Whenever plastic is used to protect slopes, install water collection measures at the base of the slope. These measures include plastic-covered berms, channels, and pipes used to convey clean rainwater away from bare soil and disturbed areas. Do not mix clean runoff from a plastic covered slope with dirty runoff from a project.
- Other uses for plastic include:
 - Temporary ditch liner.
 - Pond liner in temporary sediment pond.
 - Liner for bermed temporary fuel storage area if plastic is not reactive to the type of fuel being stored.
 - Emergency slope protection during heavy rains.
 - Temporary drainpipe (“elephant trunk”) used to direct water.

Design and Installation Specifications

- Plastic slope cover must be installed as follows:
 1. Run plastic up and down the slope, not across the slope.
 2. Plastic may be installed perpendicular to a slope if the slope length is less than 10 feet.

3. Provide a minimum of 8-inch overlap at the seams.
 4. On long or wide slopes, or slopes subject to wind, tape all seams.
 5. Place plastic into a small (12-inch wide by 6-inch deep) slot trench at the top of the slope and backfill with soil to keep water from flowing underneath.
 6. Place sand filled burlap or geotextile bags every 3 to 6 feet along seams and tie them together with twine to hold them in place.
 7. Inspect plastic for rips, tears, and open seams regularly and repair immediately. This prevents high velocity runoff from contacting bare soil, which causes extreme erosion.
 8. Sandbags may be lowered into place tied to ropes. However, all sandbags must be staked in place.
- Plastic sheeting shall have a minimum thickness of 0.06 millimeters.
 - If erosion at the toe of a slope is likely, a gravel berm, riprap, or other suitable protection shall be installed at the toe of the slope in order to reduce the velocity of runoff.

Maintenance Standards

- Torn sheets must be replaced and open seams repaired.
- Completely remove and replace the plastic if it begins to deteriorate due to ultraviolet radiation.
- Completely remove plastic when no longer needed.
- Dispose of old tires used to weight down plastic sheeting appropriately.

Approved as Functionally Equivalent

Ecology has approved products as able to meet the requirements of this BMP. The products did not pass through the Technology Assessment Protocol – Ecology (TAPE) process. Local jurisdictions may choose not to accept these products, or may require additional testing prior to consideration for local use. Products that Ecology has approved as functionally equivalent are available for review on Ecology's website at:

<https://ecology.wa.gov/Regulations-Permits/Guidance-technical-assistance/Stormwater-permittee-guidance-resources/Emerging-stormwater-treatment-technologies>

BMP C124: Sodding

Purpose

The purpose of sodding is to establish turf for immediate erosion protection and to stabilize drainage paths where concentrated overland flow will occur.

BMP C140: Dust Control

Purpose

Dust control prevents wind transport of dust from disturbed soil surfaces onto roadways, drainage ways, and surface waters.

Conditions of Use

Use dust control in areas (including roadways) subject to surface and air movement of dust where on-site or off-site impacts to roadways, drainage ways, or surface waters are likely.

Design and Installation Specifications

- Vegetate or mulch areas that will not receive vehicle traffic. In areas where planting, mulching, or paving is impractical, apply gravel or landscaping rock.
- Limit dust generation by clearing only those areas where immediate activity will take place, leaving the remaining area(s) in the original condition. Maintain the original ground cover as long as practical.
- Construct natural or artificial windbreaks or windscreens. These may be designed as enclosures for small dust sources.
- Sprinkle the site with water until the surface is wet. Repeat as needed. To prevent carryout of mud onto the street, refer to [BMP C 105: Stabilized Construction Access](#) and [BMP C 106: Wheel Wash](#).
- Irrigation water can be used for dust control. Irrigation systems should be installed as a first step on sites where dust control is a concern.
- Spray exposed soil areas with a dust palliative, following the manufacturer's instructions and cautions regarding handling and application. Used oil is prohibited from use as a dust suppressant. Local governments may approve other dust palliatives such as calcium chloride or PAM.
- PAM ([BMP C 126: Polyacrylamide \(PAM\) for Soil Erosion Protection](#)) added to water at a rate of 0.5 pounds per 1,000 gallons of water per acre and applied from a water truck is more effective than water alone. This is due to increased infiltration of water into the soil and reduced evaporation. In addition, small soil particles are bonded together and are not as easily transported by wind. Adding PAM may reduce the quantity of water needed for dust control. Note that the application rate specified here applies to this BMP, and is not the same application rate that is specified in [BMP C 126: Polyacrylamide \(PAM\) for Soil Erosion Protection](#), but the downstream protections still apply.

Refer to [BMP C 126: Polyacrylamide \(PAM\) for Soil Erosion Protection](#) for conditions of use. PAM shall not be directly applied to water or allowed to enter a water body.

- Contact your local Air Pollution Control Authority for guidance and training on other dust control measures. Compliance with the local Air Pollution Control Authority constitutes

compliance with this BMP.

- Use vacuum street sweepers.
- Remove mud and other dirt promptly so it does not dry and then turn into dust.
- Techniques that can be used for unpaved roads and lots include:
 - Lower speed limits. High vehicle speed increases the amount of dust stirred up from unpaved roads and lots.
 - Upgrade the road surface strength by improving particle size, shape, and mineral types that make up the surface and base materials.
 - Add surface gravel to reduce the source of dust emission. Limit the amount of fine particles (those smaller than .075 mm) to 10 to 20 percent.
 - Use geotextile fabrics to increase the strength of new roads or roads undergoing reconstruction.
 - Encourage the use of alternate, paved routes, if available.
 - Apply chemical dust suppressants using the admix method, blending the product with the top few inches of surface material. Suppressants may also be applied as surface treatments.
 - Limit dust-causing work on windy days.
 - Pave unpaved permanent roads and other trafficked areas.

Maintenance Standards

Respray area as necessary to keep dust to a minimum.

BMP C150: Materials on Hand

Purpose

Keep quantities of erosion prevention and sediment control materials on the project site at all times to be used for regular maintenance and emergency situations such as unexpected heavy rains. Having these materials on-site reduces the time needed to replace existing or implement new BMPs when inspections indicate that existing BMPs are not meeting the Construction SWPPP requirements. In addition, contractors can save money by buying some materials in bulk and storing them at their office or yard.

Conditions of Use

- Construction projects of any size or type can benefit from having materials on hand. A small commercial development project could have a roll of plastic and some gravel available for immediate protection of bare soil and temporary berm construction. A large earthwork project, such as highway construction, might have several tons of straw, several rolls of plastic, flexible

pipe, sandbags, geotextile fabric and steel “T” posts.

- Materials should be stockpiled and readily available before any site clearing, grubbing, or earthwork begins. A large contractor or project proponent could keep a stockpile of materials that are available for use on several projects.
- If storage space at the project site is at a premium, the contractor could maintain the materials at their office or yard. The office or yard must be less than an hour from the project site.

Design and Installation Specifications

Depending on project type, size, complexity, and length, materials and quantities will vary. A good minimum list of items that will cover numerous situations includes:

- Clear Plastic, 6 mil
- Drainpipe, 6 or 8 inch diameter
- Sandbags, filled
- Straw Bales for mulching
- Quarry Spalls
- Washed Gravel
- Geotextile Fabric
- Catch Basin Inserts
- Steel "T" Posts
- Silt fence material
- Straw Wattles

Maintenance Standards

- All materials with the exception of the quarry spalls, steel “T” posts, and gravel should be kept covered and out of both sun and rain.
- Re-stock materials as needed.

BMP C151: Concrete Handling

Purpose

Concrete work can generate process water and slurry that contain fine particles and high pH, both of which can violate water quality standards in the receiving water. Concrete spillage or concrete discharge to waters of the State is prohibited. Use this BMP to minimize and eliminate concrete, concrete process water, and concrete slurry from entering waters of the State.

Conditions of Use

Any time concrete is used, utilize these management practices. Concrete construction project components include, but are not limited to:

- Curbs
- Sidewalks
- Roads
- Bridges
- Foundations
- Floors
- Runways

Disposal options for concrete, in order of preference are:

1. Off-site disposal
2. Concrete wash-out areas (see [BMP C154: Concrete Washout Area](#))
3. De minimus washout to formed areas awaiting concrete

Design and Installation Specifications

- Wash concrete truck drums at an approved off-site location or in designated concrete washout areas only. Do not wash out concrete trucks onto the ground (including formed areas awaiting concrete), or into storm drains, open ditches, streets, or streams. Refer to [BMP C154: Concrete Washout Area](#) for information on concrete washout areas.
 - Return unused concrete remaining in the truck and pump to the originating batch plant for recycling. Do not dump excess concrete on site, except in designated concrete washout areas as allowed in [BMP C154: Concrete Washout Area](#).
- Wash small concrete handling equipment (e.g. hand tools, screeds, shovels, rakes, floats, trowels, and wheelbarrows) into designated concrete washout areas or into formed areas awaiting concrete pour.
- At no time shall concrete be washed off into the footprint of an area where an infiltration feature will be installed.
- Wash equipment difficult to move, such as concrete paving machines, in areas that do not directly drain to natural or constructed stormwater conveyance or potential infiltration areas.
- Do not allow washwater from areas, such as concrete aggregate driveways, to drain directly (without detention or treatment) to natural or constructed stormwater conveyances.
- Contain washwater and leftover product in a lined container when no designated concrete washout areas (or formed areas, allowed as described above) are available. Dispose of contained concrete and concrete washwater (process water) properly.

- Always use forms or solid barriers for concrete pours, such as pilings, within 15-feet of surface waters.
- Refer to [BMP C252: Treating and Disposing of High pH Water](#) for pH adjustment requirements.
- Refer to the Construction Stormwater General Permit (CSWGP) for pH monitoring requirements if the project involves one of the following activities:
 - Significant concrete work (as defined in the CSWGP).
 - The use of soils amended with (but not limited to) Portland cement-treated base, cement kiln dust or fly ash.
 - Discharging stormwater to segments of water bodies on the 303(d) list (Category 5) for high pH.

Maintenance Standards

Check containers for holes in the liner daily during concrete pours and repair the same day.

BMP C152: Sawcutting and Surfacing Pollution Prevention

Purpose

Sawcutting and surfacing operations generate slurry and process water that contains fine particles and high pH (concrete cutting), both of which can violate the water quality standards in the receiving water. Concrete spillage or concrete discharge to waters of the State is prohibited. Use this BMP to minimize and eliminate process water and slurry created through sawcutting or surfacing from entering waters of the State.

Conditions of Use

Utilize these management practices anytime sawcutting or surfacing operations take place. Sawcutting and surfacing operations include, but are not limited to:

- Sawing
- Coring
- Grinding
- Roughening
- Hydro-demolition
- Bridge and road surfacing

Design and Installation Specifications

- Vacuum slurry and cuttings during cutting and surfacing operations.
- Slurry and cuttings shall not remain on permanent concrete or asphalt pavement overnight.
- Slurry and cuttings shall not drain to any natural or constructed drainage conveyance including stormwater systems. This may require temporarily blocking catch basins.
- Dispose of collected slurry and cuttings in a manner that does not violate ground water or surface water quality standards.
- Do not allow process water generated during hydro-demolition, surface roughening or similar operations to drain to any natural or constructed drainage conveyance including stormwater systems. Dispose of process water in a manner that does not violate ground water or surface water quality standards.
- Handle and dispose of cleaning waste material and demolition debris in a manner that does not cause contamination of water. Dispose of sweeping material from a pick-up sweeper at an appropriate disposal site.

Maintenance Standards

Continually monitor operations to determine whether slurry, cuttings, or process water could enter waters of the state. If inspections show that a violation of water quality standards could occur, stop operations and immediately implement preventive measures such as berms, barriers, secondary containment, and/or vacuum trucks.

BMP C153: Material Delivery, Storage, and Containment

Purpose

Prevent, reduce, or eliminate the discharge of pollutants to the stormwater system or watercourses from material delivery and storage. Minimize the storage of hazardous materials on-site, store materials in a designated area, and install secondary containment.

Conditions of Use

Use at construction sites with delivery and storage of the following materials:

- Petroleum products such as fuel, oil and grease
- Soil stabilizers and binders (e.g., Polyacrylamide)
- Fertilizers, pesticides and herbicides
- Detergents
- Asphalt and concrete compounds

- Hazardous chemicals such as acids, lime, adhesives, paints, solvents, and curing compounds
- Any other material that may be detrimental if released to the environment

Design and Installation Specifications

- The temporary storage area should be located away from vehicular traffic, near the construction entrance(s), and away from waterways or storm drains.
- Safety Data Sheets (SDS) should be supplied for all materials stored. Chemicals should be kept in their original labeled containers.
- Hazardous material storage on-site should be minimized.
- Hazardous materials should be handled as infrequently as possible.
- During the wet weather season (Oct 1 – April 30), consider storing materials in a covered area.
- Materials should be stored in secondary containments, such as an earthen dike, horse trough, or even a children’s wading pool for non-reactive materials such as detergents, oil, grease, and paints. Small amounts of material may be secondarily contained in “bus boy” trays or concrete mixing trays.
- Do not store chemicals, drums, or bagged materials directly on the ground. Place these items on a pallet and, when possible, within secondary containment.
- If drums must be kept uncovered, store them at a slight angle to reduce ponding of rainwater on the lids to reduce corrosion. Domed plastic covers are inexpensive and snap to the top of drums, preventing water from collecting.
- Liquids, petroleum products, and substances listed in 40 CFR Parts 110, 117, or 302 shall be stored in approved containers and drums and shall not be overfilled. Containers and drums shall be stored in temporary secondary containment facilities.
- Temporary secondary containment facilities shall provide for a spill containment volume able to contain 10% of the total enclosed container volume of all containers, or 110% of the capacity of the largest container within its boundary, whichever is greater.
- Secondary containment facilities shall be impervious to the materials stored therein for a minimum contact time of 72 hours.
- Sufficient separation should be provided between stored containers to allow for spill cleanup and emergency response access.
- During the wet weather season (Oct 1 – April 30), each secondary containment facility shall be covered during non-working days, prior to and during rain events.
- Keep material storage areas clean, organized and equipped with an ample supply of appropriate spill clean-up material (spill kit).
- The spill kit should include, at a minimum:

- 1-Water Resistant Nylon Bag
- 3-Oil Absorbent Socks 3"x 4'
- 2-Oil Absorbent Socks 3"x 10'
- 12-Oil Absorbent Pads 17"x19"
- 1-Pair Splash Resistant Goggles
- 3-Pair Nitrile Gloves
- 10-Disposable Bags with Ties
- Instructions

Maintenance Standards

- Secondary containment facilities shall be maintained free of accumulated rainwater and spills. In the event of spills or leaks, accumulated rainwater and spills shall be collected and placed into drums. These liquids shall be handled as hazardous waste unless testing determines them to be non-hazardous.
- Re-stock spill kit materials as needed.

BMP C154: Concrete Washout Area

Purpose

Prevent or reduce the discharge of pollutants from concrete waste to stormwater by conducting washout off-site, or performing on-site washout in a designated area.

Conditions of Use

Concrete washout areas are implemented on construction projects where:

- Concrete is used as a construction material
- It is not possible to dispose of all concrete wastewater and washout off-site (ready mix plant, etc.).
- Concrete truck drums are washed on-site.

Note that auxiliary concrete truck components (e.g. chutes and hoses) and small concrete handling equipment (e.g. hand tools, screeds, shovels, rakes, floats, trowels, and wheelbarrows) may be washed into formed areas awaiting concrete pour.

At no time shall concrete be washed off into the footprint of an area where an infiltration feature will be installed.

BMP C160: Certified Erosion and Sediment Control Lead

Purpose

The project proponent designates at least one person as the responsible representative in charge of erosion and sediment control (ESC), and water quality protection. The designated person shall be responsible for ensuring compliance with all local, state, and federal erosion and sediment control and water quality requirements. Construction sites one acre or larger that discharge to waters of the State must designate a Certified Erosion and Sediment Control Lead (CESCL) as the responsible representative.

Conditions of Use

A CESCL shall be made available on projects one acre or larger that discharge stormwater to surface waters of the state. Sites less than one acre may have a person without CESCL certification conduct inspections.

The CESCL shall:

- Have a current certificate proving attendance in an erosion and sediment control training course that meets the minimum ESC training and certification requirements established by Ecology.

Ecology has provided the minimum requirements for CESCL course training, as well as a list of ESC training and certification providers at:

<https://ecology.wa.gov/Regulations-Permits/Permits-certifications/Certified-erosion-sediment-control>

OR

- Be a Certified Professional in Erosion and Sediment Control (CPESC). For additional information go to:

<http://www.envirocertintl.org/cpesc/>

Specifications

- CESCL certification shall remain valid for three years.
- The CESCL shall have authority to act on behalf of the contractor or project proponent and shall be available, or on-call, 24 hours per day throughout the period of construction.
- The Construction SWPPP shall include the name, telephone number, fax number, and address of the designated CESCL. See [II-2 Construction Stormwater Pollution Prevention Plans \(Construction SWPPPs\)](#).
- A CESCL may provide inspection and compliance services for multiple construction projects in the same geographic region, but must be on site whenever earthwork activities are

occurring that could generate release of turbid water.

- Duties and responsibilities of the CESCL shall include, but are not limited to the following:
 - Maintaining a permit file on site at all times which includes the Construction SWPPP and any associated permits and plans.
 - Directing BMP installation, inspection, maintenance, modification, and removal.
 - Updating all project drawings and the Construction SWPPP with changes made.
 - Completing any sampling requirements including reporting results using electronic Discharge Monitoring Reports (WebDMR).
 - Facilitate, participate in, and take corrective actions resulting from inspections performed by outside agencies or the owner.
 - Keeping daily logs, and inspection reports. Inspection reports should include:
 - Inspection date/time.
 - Weather information; general conditions during inspection and approximate amount of precipitation since the last inspection.
 - Visual monitoring results, including a description of discharged stormwater. The presence of suspended sediment, turbid water, discoloration, and oil sheen shall be noted, as applicable.
 - Any water quality monitoring performed during inspection.
 - General comments and notes, including a brief description of any BMP repairs, maintenance or installations made as a result of the inspection.
 - A summary or list of all BMPs implemented, including observations of all erosion/sediment control structures or practices. The following shall be noted:
 1. Locations of BMPs inspected.
 2. Locations of BMPs that need maintenance.
 3. Locations of BMPs that failed to operate as designed or intended.
 4. Locations of where additional or different BMPs are required.

BMP C162: Scheduling

Purpose

Sequencing a construction project reduces the amount and duration of soil exposed to erosion by wind, rain, runoff, and vehicle tracking.

Conditions of Use

The construction sequence schedule is an orderly listing of all major land-disturbing activities together with the necessary erosion and sedimentation control measures planned for the project. This type of schedule guides the contractor on work to be done before other work is started so that serious erosion and sedimentation problems can be avoided.

Following a specified work schedule that coordinates the timing of land-disturbing activities and the installation of control measures is perhaps the most cost-effective way of controlling erosion during construction. The removal of ground cover leaves a site vulnerable to erosion. Construction sequencing that limits land clearing, provides timely installation of erosion and sedimentation controls, and restores protective cover quickly can significantly reduce the erosion potential of a site.

Design Considerations

- Minimize construction during rainy periods.
- Schedule projects to disturb only small portions of the site at any one time. Complete grading as soon as possible. Immediately stabilize the disturbed portion before grading the next portion. Practice staged seeding in order to revegetate cut and fill slopes as the work progresses.

II-3.3 Construction Runoff BMPs

BMP C200: Interceptor Dike and Swale

Purpose

Provide a dike of compacted soil or a swale at the top or base of a disturbed slope or along the perimeter of a disturbed construction area to convey stormwater. Use the dike and/or swale to intercept the runoff from unprotected areas and direct it to areas where erosion can be controlled. This can prevent storm runoff from entering the work area or sediment-laden runoff from leaving the construction site.

Conditions of Use

Use an interceptor dike or swale where runoff from an exposed site or disturbed slope must be conveyed to an erosion control BMP which can safely convey the stormwater.

- Locate upslope of a construction site to prevent runoff from entering the disturbed area.
- When placed horizontally across a disturbed slope, it reduces the amount and velocity of runoff flowing down the slope.
- Locate downslope to collect runoff from a disturbed area and direct it to a sediment BMP (e.g. [BMP C240: Sediment Trap](#) or [BMP C241: Sediment Pond \(Temporary\)](#)).

Design and Installation Specifications

- Dike and/or swale and channel must be stabilized with temporary or permanent vegetation or other channel protection during construction.
 - Steep grades require channel protection and check dams.
 - Review construction for areas where overtopping may occur.
 - Can be used at the top of new fill before vegetation is established.
 - May be used as a permanent diversion channel to carry the runoff.
 - Contributing area for an individual dike or swale should be one acre or less.
 - Design the dike and/or swale to contain flows calculated by one of the following methods:
 - Single Event Hydrograph Method: The peak volumetric flow rate calculated using a 10-minute time step from a Type 1A, 10-year, 24-hour frequency storm for the worst-case land cover condition.
- OR
- Continuous Simulation Method: The 10-year peak flow rate, as determined by an approved continuous runoff model with a 15-minute time step for the worst-case land cover condition.

Worst-case land cover conditions (i.e., producing the most runoff) should be used for analysis (in most cases, this would be the land cover conditions just prior to final landscaping).

Interceptor Dikes

Interceptor dikes shall meet the following criteria:

- Top Width: 2 feet minimum.
- Height: 1.5 feet minimum on berm.
- Side Slope: 2H:1V or flatter.
- Grade: Depends on topography, however, dike system minimum is 0.5%, and maximum is 1%.
- Compaction: Minimum of 90 percent ASTM D698 standard proctor.
- Stabilization: Depends on velocity and reach. Inspect regularly to ensure stability.
- Ground Slopes <5%: Seed and mulch applied within 5 days of dike construction (see [BMP C121: Mulching](#)).
- Ground Slopes 5 - 40%: Dependent on runoff velocities and dike materials. Stabilization should be done immediately using either sod or riprap, or other measures to avoid erosion.
- The upslope side of the dike shall provide positive drainage to the dike outlet. No erosion shall

occur at the outlet. Provide energy dissipation measures as necessary. Sediment-laden runoff must be released through a sediment trapping facility.

- Minimize construction traffic over temporary dikes. Use temporary cross culverts for channel crossing.
- See [Table II-3.8: Horizontal Spacing of Interceptor Dikes Along Ground Slope](#) for recommended horizontal spacing between dikes.

Table II-3.8: Horizontal Spacing of Interceptor Dikes Along Ground Slope

Average Slope	Slope Percent	Flowpath Length
20H:1V or less	3-5%	300 feet
(10 to 20)H:1V	5-10%	200 feet
(4 to 10)H:1V	10-25%	100 feet
(2 to 4)H:1V	25-50%	50 feet

Interceptor Swales

Interceptor swales shall meet the following criteria:

- Bottom Width: 2 feet minimum; the cross-section bottom shall be level.
- Depth: 1-foot minimum.
- Side Slope: 2H:1V or flatter.
- Grade: Maximum 5 percent, with positive drainage to a suitable outlet (such as [BMP C241: Sediment Pond \(Temporary\)](#)).
- Stabilization: Seed as per [BMP C120: Temporary and Permanent Seeding](#), or [BMP C202: Riprap Channel Lining](#), 12 inches thick riprap pressed into the bank and extending at least 8 inches vertical from the bottom.

Maintenance Standards

- Inspect diversion dikes and interceptor swales once a week and after every rainfall. Immediately remove sediment from the flow area.
- Damage caused by construction traffic or other activity must be repaired before the end of each working day.
- Check outlets and make timely repairs as needed to avoid gully formation. When the area below the temporary diversion dike is permanently stabilized, remove the dike and fill and stabilize the channel to blend with the natural surface.

BMP C207: Check Dams

Purpose

Construction of check dams across a swale or ditch reduces the velocity of concentrated flow and dissipates energy at the check dam.

Conditions of Use

Use check dams where temporary or permanent channels are not yet vegetated, channel lining is infeasible, and/or velocity checks are required.

- Check dams may not be placed in streams unless approved by the State Department of Fish and Wildlife.
- Check dams may not be placed in wetlands without approval from a permitting agency.
- Do not place check dams below the expected backwater from any salmonid bearing water between October 1 and May 31 to ensure that there is no loss of high flow refuge habitat for overwintering juvenile salmonids and emergent salmonid fry.

Design and Installation Specifications

- Construct rock check dams from appropriately sized rock. The rock used must be large enough to stay in place given the expected design flow through the channel. The rock must be placed by hand or by mechanical means (do not dump the rock to form the dam) to achieve complete coverage of the ditch or swale and to ensure that the center of the dam is lower than the edges.
- Check dams may also be constructed of either rock or pea-gravel filled bags. Numerous new products are also available for this purpose. They tend to be re-usable, quick and easy to install, effective, and cost efficient.
- Place check dams perpendicular to the flow of water.
- The check dam should form a triangle when viewed from the side. This prevents undercutting as water flows over the face of the check dam rather than falling directly onto the ditch bottom.
- Before installing check dams, impound and bypass upstream water flow away from the work area. Options for bypassing include pumps, siphons, or temporary channels.
- Check dams combined with sumps work more effectively at slowing flow and retaining sediment than a check dam alone. A deep sump should be provided immediately upstream of the check dam.
- In some cases, if carefully located and designed, check dams can remain as permanent installations with very minor regrading. They may be left as either spillways, in which case accumulated sediment would be graded and seeded, or as check dams to prevent further sediment from leaving the site.
- The maximum spacing between check dams shall be such that the downstream toe of the

upstream dam is at the same elevation as the top of the downstream dam.

- Keep the maximum height at 2 feet at the center of the check dam.
- Keep the center of the check dam at least 12 inches lower than the outer edges at natural ground elevation.
- Keep the side slopes of the check dam at 2H:1V or flatter.
- Key the stone into the ditch banks and extend it beyond the abutments a minimum of 18 inches to avoid washouts from overflow around the dam.
- Use filter fabric foundation under a rock or sand bag check dam. If a blanket ditch liner is used, filter fabric is not necessary. A piece of organic or synthetic blanket cut to fit will also work for this purpose.
- In the case of grass-lined ditches and swales, all check dams and accumulated sediment shall be removed when the grass has matured sufficiently to protect the ditch or swale - unless the slope of the swale is greater than 4 percent. The area beneath the check dams shall be seeded and mulched immediately after dam removal.
- Ensure that channel appurtenances, such as culvert entrances below check dams, are not subject to damage or blockage from displaced stones.
- See [Figure II-3.16: Rock Check Dam](#).

Maintenance Standards

Check dams shall be monitored for performance and sediment accumulation during and after each rainfall that produces runoff. Sediment shall be removed when it reaches one half the sump depth.

- Anticipate submergence and deposition above the check dam and erosion from high flows around the edges of the dam.
- If significant erosion occurs between dams, install a protective riprap liner in that portion of the channel. See [BMP C202: Riprap Channel Lining](#).

Approved as Functionally Equivalent

Ecology has approved products as able to meet the requirements of this BMP. The products did not pass through the Technology Assessment Protocol – Ecology (TAPE) process. Local jurisdictions may choose not to accept these products, or may require additional testing prior to consideration for local use. Products that Ecology has approved as functionally equivalent are available for review on Ecology's website at:

<https://ecology.wa.gov/Regulations-Permits/Guidance-technical-assistance/Stormwater-permittee-guidance-resources/Emerging-stormwater-treatment-technologies>

Figure II-3.16: Rock Check Dam

View Looking Upstream

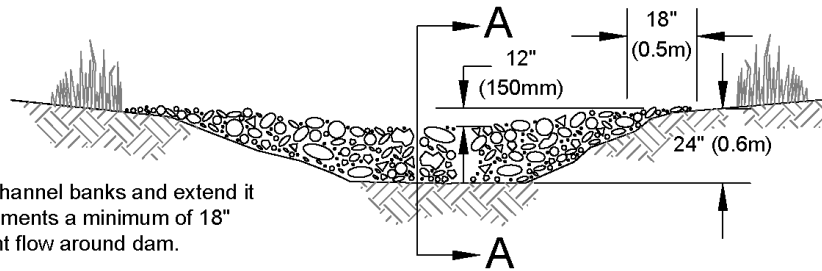

Note:
Key stone into channel banks and extend it beyond the abutments a minimum of 18" (0.5m) to prevent flow around dam.

Section A-A

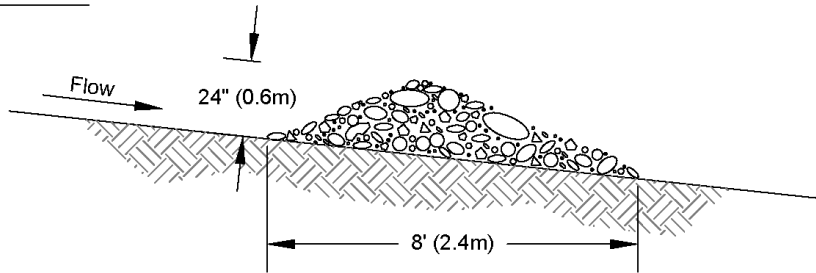

Spacing Between Check Dams

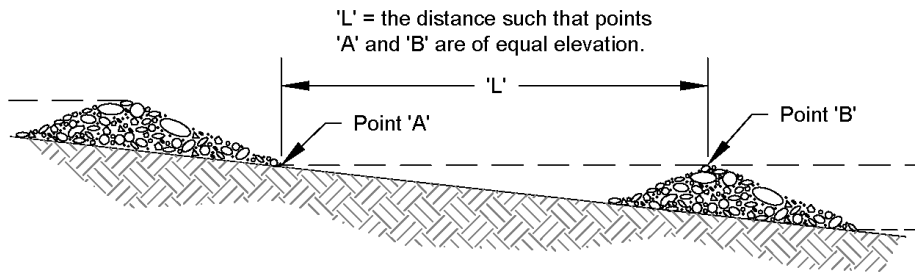

NOT TO SCALE



Rock Check Dam

Revised June 2016

Please see <http://www.ecy.wa.gov/copyright.html> for copyright notice including permissions, limitation of liability, and disclaimer.

and staples.

- In the case of grass-lined ditches and swales, check dams and accumulated sediment shall be removed when the grass has matured sufficiently to protect the ditch or swale unless the slope of the swale is greater than 4 percent. The area beneath the check dams shall be seeded and mulched immediately after dam removal.

Maintenance Standards

- Inspect TSDs for performance and sediment accumulation during and after each rainfall that produces runoff. Remove sediment when it reaches one half the height of the TSD.
- Anticipate submergence and deposition above the TSD and erosion from high flows around the edges of the TSD. Immediately repair any damage or any undercutting of the TSD.

BMP C209: Outlet Protection

Purpose

Outlet protection prevents scour at conveyance outlets and minimizes the potential for downstream erosion by reducing the velocity of concentrated stormwater flows.

Conditions of Use

Use outlet protection at the outlets of all ponds, pipes, ditches, or other conveyances that discharge to a natural or manmade drainage feature such as a stream, wetland, lake, or ditch.

Design and Installation Specifications

- The receiving channel at the outlet of a pipe shall be protected from erosion by lining a minimum of 6 feet downstream and extending up the channel sides a minimum of 1-foot above the maximum tailwater elevation, or 1-foot above the crown, whichever is higher. For pipes larger than 18 inches in diameter, the outlet protection lining of the channel shall be four times the diameter of the outlet pipe.
- Standard wingwalls, tapered outlets, and paved channels should also be considered when appropriate for permanent culvert outlet protection ([WSDOT, 2015](#)).
- [BMP C122: Nets and Blankets](#) or [BMP C202: Riprap Channel Lining](#) provide suitable options for lining materials.
- With low flows, [BMP C201: Grass-Lined Channels](#) can be an effective alternative for lining material.
- The following guidelines shall be used for outlet protection with riprap:
 - If the discharge velocity at the outlet is less than 5 fps, use 2-inch to 8-inch riprap. Minimum thickness is 1-foot.
 - For 5 to 10 fps discharge velocity at the outlet, use 24-inch to 48-inch riprap. Minimum

thickness is 2 feet.

- For outlets at the base of steep slope pipes (pipe slope greater than 10 percent), use an engineered energy dissipator.
- Filter fabric or erosion control blankets should always be used under riprap to prevent scour and channel erosion. See [BMP C122: Nets and Blankets](#).
- Bank stabilization, bioengineering, and habitat features may be required for disturbed areas. This work may require a Hydraulic Project Approval (HPA) from the Washington State Department of Fish and Wildlife. See [I-2.11 Hydraulic Project Approvals](#).

Maintenance Standards

- Inspect and repair as needed.
- Add rock as needed to maintain the intended function.
- Clean energy dissipator if sediment builds up.

BMP C220: Inlet Protection

Purpose

Inlet protection prevents coarse sediment from entering drainage systems prior to permanent stabilization of the disturbed area.

Conditions of Use

Use inlet protection at inlets that are operational before permanent stabilization of the disturbed areas that contribute runoff to the inlet. Provide protection for all storm drain inlets downslope and within 500 feet of a disturbed or construction area, unless those inlets are preceded by a sediment trapping BMP.

Also consider inlet protection for lawn and yard drains on new home construction. These small and numerous drains coupled with lack of gutters can add significant amounts of sediment into the roof drain system. If possible, delay installing lawn and yard drains until just before landscaping, or cap these drains to prevent sediment from entering the system until completion of landscaping. Provide 18-inches of sod around each finished lawn and yard drain.

[Table II-3.10: Storm Drain Inlet Protection](#) lists several options for inlet protection. All of the methods for inlet protection tend to plug and require a high frequency of maintenance. Limit contributing drainage areas for an individual inlet to one acre or less. If possible, provide emergency overflows with additional end-of-pipe treatment where stormwater ponding would cause a hazard.

Table II-3.10: Storm Drain Inlet Protection

Type of Inlet Protection	Emergency Overflow	Applicable for Paved/ Earthen Surfaces	Conditions of Use
Drop Inlet Protection			
Excavated drop inlet protection	Yes, temporary flooding may occur	Earthen	Applicable for heavy flows. Easy to maintain. Large area requirement: 30'x30'/acre
Block and gravel drop inlet protection	Yes	Paved or Earthen	Applicable for heavy concentrated flows. Will not pond.
Gravel and wire drop inlet protection	No	Paved or Earthen	Applicable for heavy concentrated flows. Will pond. Can withstand traffic.
Catch basin filters	Yes	Paved or Earthen	Frequent maintenance required.
Curb Inlet Protection			
Curb inlet protection with wooden weir	Small capacity overflow	Paved	Used for sturdy, more compact installation.
Block and gravel curb inlet protection	Yes	Paved	Sturdy, but limited filtration.
Culvert Inlet Protection			
Culvert inlet sediment trap	N/A	N/A	18 month expected life.

Design and Installation Specifications

Excavated Drop Inlet Protection

Excavated drop inlet protection consists of an excavated impoundment around the storm drain inlet. Sediment settles out of the stormwater prior to entering the storm drain. Design and installation specifications for excavated drop inlet protection include:

- Provide a depth of 1-2 ft as measured from the crest of the inlet structure.
- Slope sides of excavation should be no steeper than 2H:1V.
- Minimum volume of excavation is 35 cubic yards.
- Shape the excavation to fit the site, with the longest dimension oriented toward the longest inflow area.
- Install provisions for draining to prevent standing water.
- Clear the area of all debris.

- Grade the approach to the inlet uniformly.
- Drill weep holes into the side of the inlet.
- Protect weep holes with screen wire and washed aggregate.
- Seal weep holes when removing structure and stabilizing area.
- Build a temporary dike, if necessary, to the down slope side of the structure to prevent bypass flow.

Block and Gravel Filter

A block and gravel filter is a barrier formed around the inlet with standard concrete blocks and gravel. See [Figure II-3.17: Block and Gravel Filter](#). Design and installation specifications for block gravel filters include:

- Provide a height of 1 to 2 feet above the inlet.
- Recess the first row of blocks 2-inches into the ground for stability.
- Support subsequent courses by placing a pressure treated wood 2x4 through the block opening.
- Do not use mortar.
- Lay some blocks in the bottom row on their side to allow for dewatering the pool.
- Place hardware cloth or comparable wire mesh with ½-inch openings over all block openings.
- Place gravel to just below the top of blocks on slopes of 2H:1V or flatter.
- An alternative design is a gravel berm surrounding the inlet, as follows:
 - Provide a slope of 3H:1V on the upstream side of the berm.
 - Provide a slope of 2H:1V on the downstream side of the berm.
 - Provide a 1-foot wide level stone area between the gravel berm and the inlet.
 - Use stones 3 inches in diameter or larger on the upstream slope of the berm.
 - Use gravel ½- to ¾-inch at a minimum thickness of 1-foot on the downstream slope of the berm.

Figure II-3.17: Block and Gravel Filter

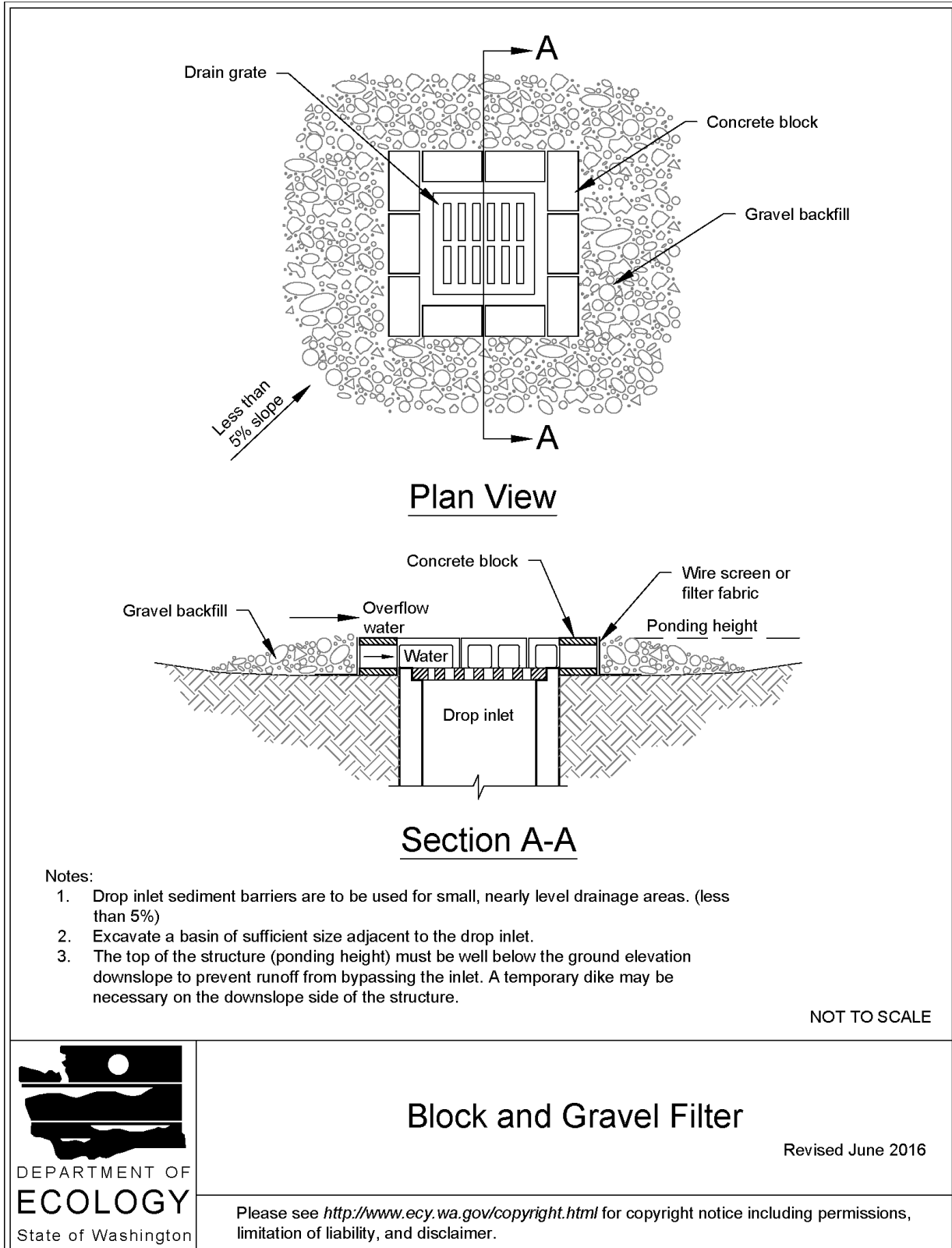

Block and Gravel Filter

Revised June 2016

Please see <http://www.ecy.wa.gov/copyright.html> for copyright notice including permissions, limitation of liability, and disclaimer.

Gravel and Wire Mesh Filter

Gravel and wire mesh filters are gravel barriers placed over the top of the inlet. This method does not provide an overflow. Design and installation specifications for gravel and wire mesh filters include:

- Use a hardware cloth or comparable wire mesh with ½-inch openings.
 - Place wire mesh over the drop inlet so that the wire extends a minimum of 1-foot beyond each side of the inlet structure.
 - Overlap the strips if more than one strip of mesh is necessary.
- Place coarse aggregate over the wire mesh.
 - Provide at least a 12-inch depth of aggregate over the entire inlet opening and extend at least 18-inches on all sides.

Catch Basin Filters

Catch basin filters are designed by manufacturers for construction sites. The limited sediment storage capacity increases the amount of inspection and maintenance required, which may be daily for heavy sediment loads. To reduce maintenance requirements, combine a catch basin filter with another type of inlet protection. This type of inlet protection provides flow bypass without overflow and therefore may be a better method for inlets located along active rights-of-way. Design and installation specifications for catch basin filters include:

- Provides 5 cubic feet of storage.
- Requires dewatering provisions.
- Provides a high-flow bypass that will not clog under normal use at a construction site.
- Insert the catch basin filter in the catch basin just below the grating.

Curb Inlet Protection with Wooden Weir

Curb inlet protection with wooden weir is an option that consists of a barrier formed around a curb inlet with a wooden frame and gravel. Design and installation specifications for curb inlet protection with wooden weirs include:

- Use wire mesh with ½-inch openings.
- Use extra strength filter cloth.
- Construct a frame.
- Attach the wire and filter fabric to the frame.
- Pile coarse washed aggregate against the wire and fabric.
- Place weight on the frame anchors.

Block and Gravel Curb Inlet Protection

Block and gravel curb inlet protection is a barrier formed around a curb inlet with concrete blocks and gravel. See [Figure II-3.18: Block and Gravel Curb Inlet Protection](#). Design and installation specifications for block and gravel curb inlet protection include:

- Use wire mesh with ½-inch openings.
- Place two concrete blocks on their sides abutting the curb at either side of the inlet opening. These are spacer blocks.
- Place a 2x4 stud through the outer holes of each spacer block to align the front blocks.
- Place blocks on their sides across the front of the inlet and abutting the spacer blocks.
- Place wire mesh over the outside vertical face.
- Pile coarse aggregate against the wire to the top of the barrier.

Figure II-3.18: Block and Gravel Curb Inlet Protection

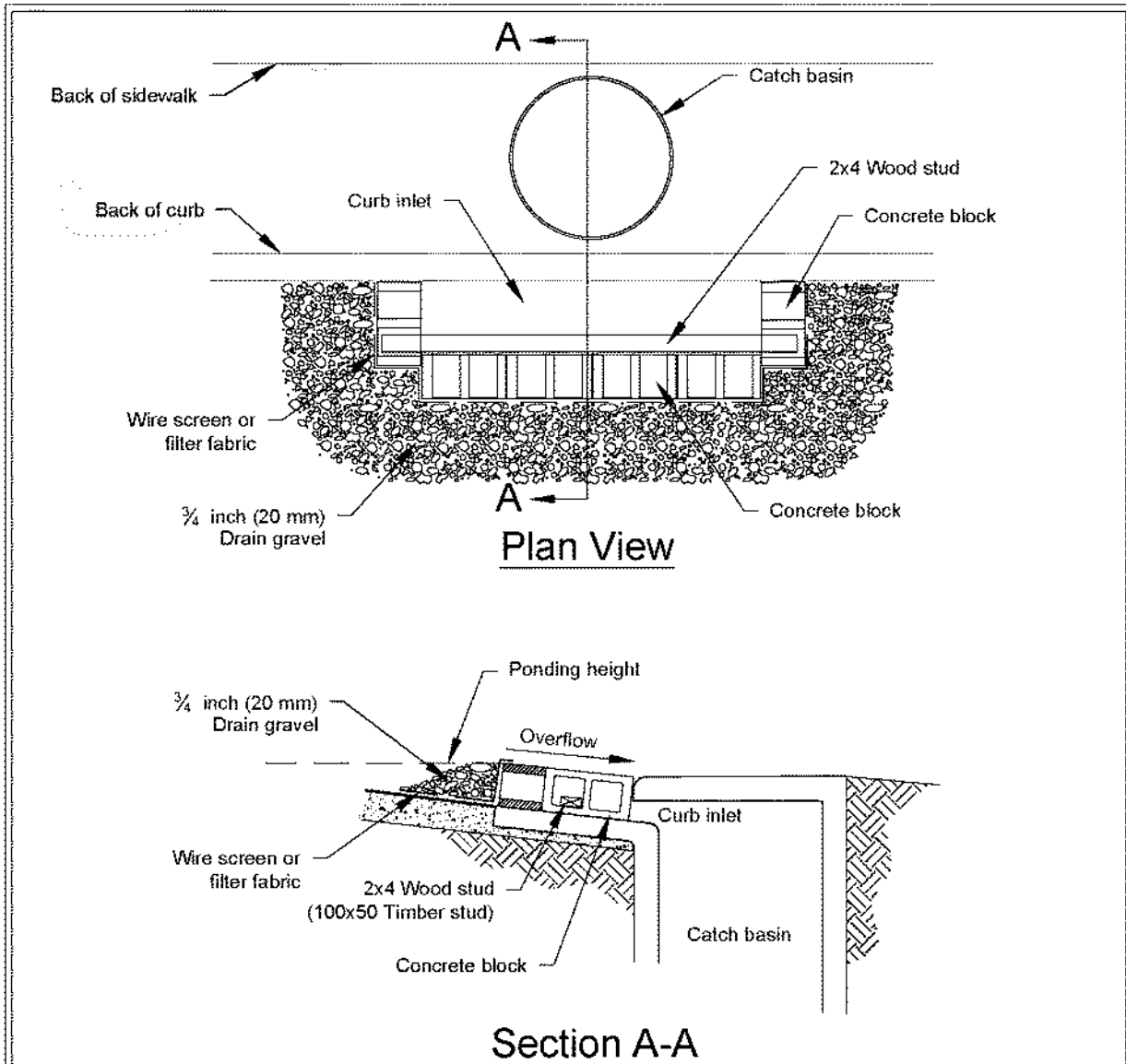

Notes:

1. Use block and gravel type sediment barrier when curb inlet is located in gently sloping street segment, where water can pond and allow sediment to separate from runoff.
2. Barrier shall allow for overflow from severe storm event.
3. Inspect barriers and remove sediment after each storm event. Sediment and gravel must be removed from the traveled way immediately.

NOT TO SCALE



Block and Gravel Curb Inlet Protection

Revised June 2016

Please see <http://www.ecy.wa.gov/copyright.html> for copyright notice including permissions, limitation of liability, and disclaimer.

Curb and Gutter Sediment Barrier

Curb and gutter sediment barrier is a sandbag or rock berm (riprap and aggregate) 3 feet high and 3 feet wide in a horseshoe shape. See [Figure II-3.19: Curb and Gutter Barrier](#). Design and installation specifications for curb and gutter sediment barrier include:

- Construct a horseshoe shaped berm, faced with coarse aggregate if using riprap, 3 feet high and 3 feet wide, at least 2 feet from the inlet.
- Construct a horseshoe shaped sedimentation trap on the upstream side of the berm. Size the trap to sediment trap standards for protecting a culvert inlet.

Figure II-3.19: Curb and Gutter Barrier

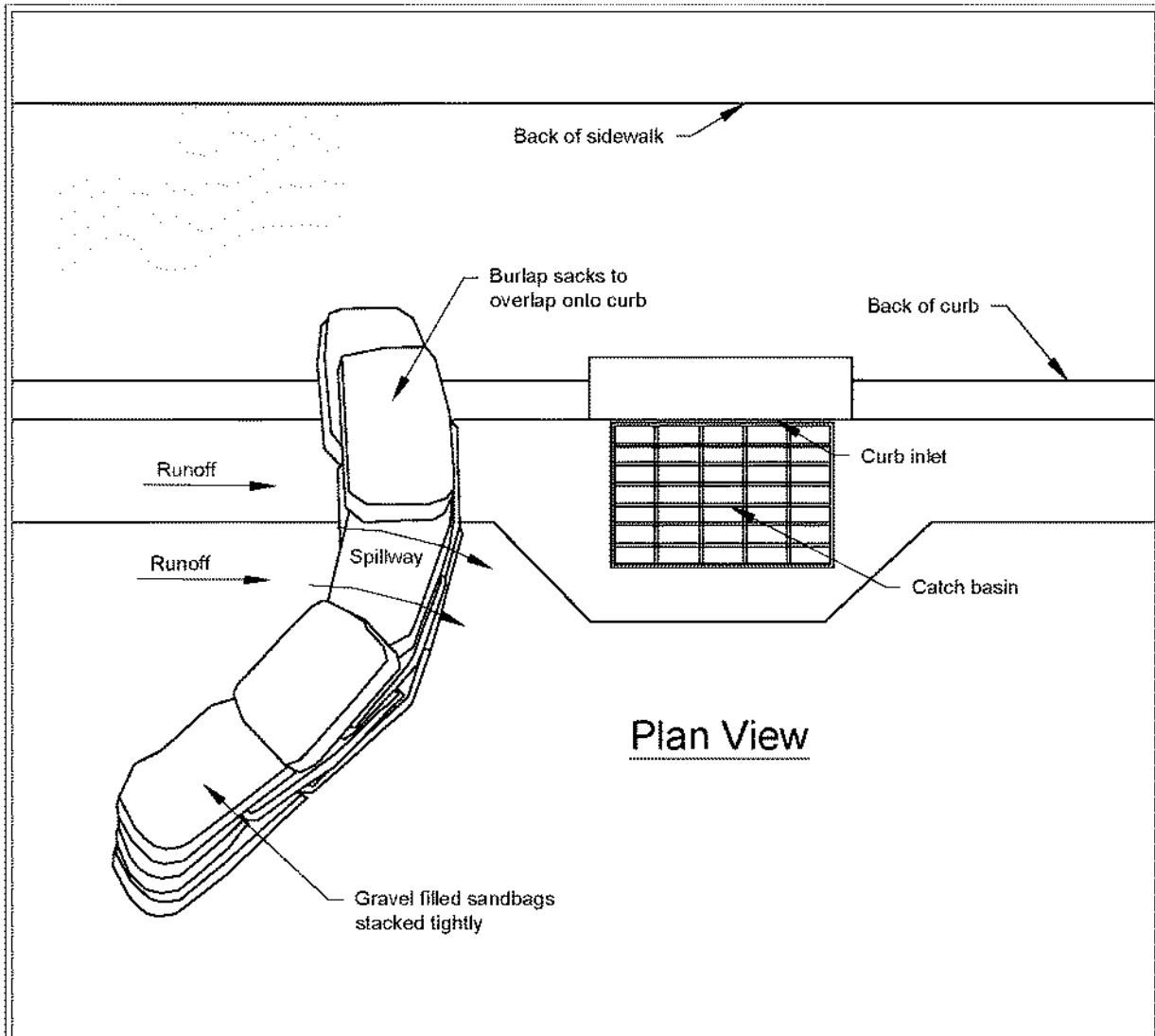

Notes:

1. Place curb type sediment barriers on gently sloping street segments, where water can pond and allow sediment to separate from runoff.
2. Sandbags of either burlap or woven 'geotextile' fabric, are filled with gravel, layered and packed tightly.
3. Leave a one sandbag gap in the top row to provide a spillway for overflow.
4. Inspect barriers and remove sediment after each storm event. Sediment and gravel must be removed from the traveled way immediately.

NOT TO SCALE



Curb and Gutter Barrier

Revised June 2016

Please see <http://www.ecy.wa.gov/copyright.html> for copyright notice including permissions, limitation of liability, and disclaimer.

Maintenance Standards

- Inspect all forms of inlet protection frequently, especially after storm events. Clean and replace clogged catch basin filters. For rock and gravel filters, pull away the rocks from the inlet and clean or replace. An alternative approach would be to use the clogged rock as fill and put fresh rock around the inlet.
- Do not wash sediment into storm drains while cleaning. Spread all excavated material evenly over the surrounding land area or stockpile and stabilize as appropriate.

Approved as Functionally Equivalent

Ecology has approved products as able to meet the requirements of this BMP. The products did not pass through the Technology Assessment Protocol – Ecology (TAPE) process. Local jurisdictions may choose not to accept these products, or may require additional testing prior to consideration for local use. Products that Ecology has approved as functionally equivalent are available for review on Ecology's website at:

<https://ecology.wa.gov/Regulations-Permits/Guidance-technical-assistance/Stormwater-permittee-guidance-resources/Emerging-stormwater-treatment-technologies>

BMP C231: Brush Barrier

Purpose

The purpose of brush barriers is to reduce the transport of coarse sediment from a construction site by providing a temporary physical barrier to sediment and reducing the runoff velocities of overland flow.

Conditions of Use

- Brush barriers may be used downslope of disturbed areas that are less than one-quarter acre.
- Brush barriers are not intended to treat concentrated flows, nor are they intended to treat substantial amounts of overland flow. Any concentrated flows must be directed to a sediment trapping BMP. The only circumstance in which overland flow can be treated solely by a brush barrier, rather than by a sediment trapping BMP, is when the area draining to the barrier is small.
- Brush barriers should only be installed on contours.

Design and Installation Specifications

- Height: 2 feet (minimum) to 5 feet (maximum).
- Width: 5 feet at base (minimum) to 15 feet (maximum).
- Filter fabric (geotextile) may be anchored over the brush berm to enhance the filtration ability of the barrier. Ten-ounce burlap is an adequate alternative to filter fabric.

BMP C233: Silt Fence

Purpose

Silt fence reduces the transport of coarse sediment from a construction site by providing a temporary physical barrier to sediment and reducing the runoff velocities of overland flow.

Conditions of Use

Silt fence may be used downslope of all disturbed areas.

- Silt fence shall prevent sediment carried by runoff from going beneath, through, or over the top of the silt fence, but shall allow the water to pass through the fence.
- Silt fence is not intended to treat concentrated flows, nor is it intended to treat substantial amounts of overland flow. Convey any concentrated flows through the drainage system to a sediment trapping BMP.
- Do not construct silt fences in streams or use in V-shaped ditches. Silt fences do not provide an adequate method of silt control for anything deeper than sheet or overland flow.

Figure II-3.22: Silt Fence

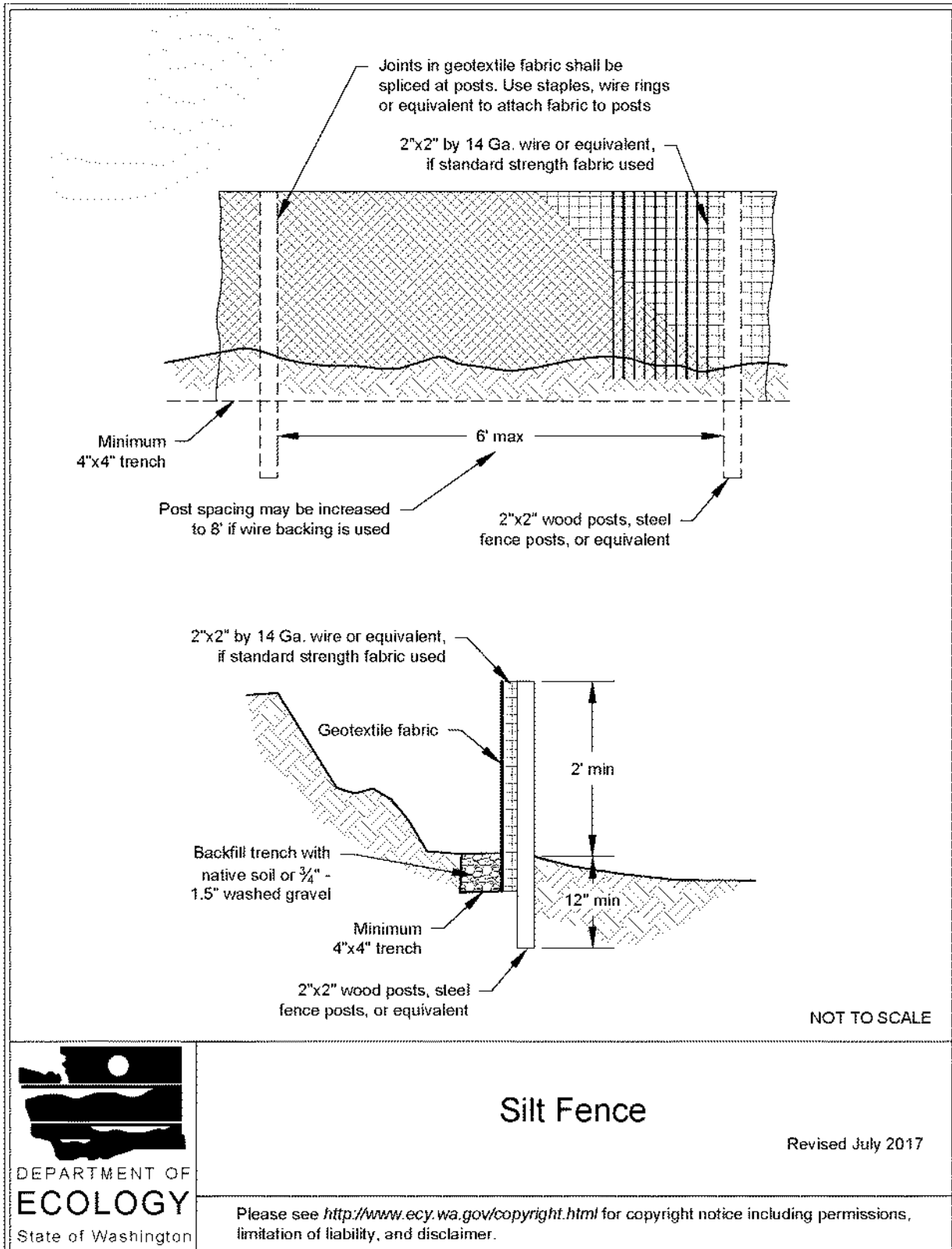

Silt Fence

Revised July 2017

Please see <http://www.ecy.wa.gov/copyright.html> for copyright notice including permissions, limitation of liability, and disclaimer.

Design and Installation Specifications

- Use in combination with other construction stormwater BMPs.
- Maximum slope steepness (perpendicular to the silt fence line) 1H:1V.
- Maximum sheet or overland flow path length to the silt fence of 100 feet.
- Do not allow flows greater than 0.5 cfs.
- Use geotextile fabric that meets the following standards. All geotextile properties listed below are minimum average roll values (i.e., the test result for any sampled roll in a lot shall meet or exceed the values shown in [Table II-3.11: Geotextile Fabric Standards for Silt Fence](#)):

Table II-3.11: Geotextile Fabric Standards for Silt Fence

Geotextile Property	Minimum Average Roll Value
Polymeric Mesh AOS (ASTM D4751)	0.60 mm maximum for slit film woven (#30 sieve). 0.30 mm maximum for all other geotextile types (#50 sieve). 0.15 mm minimum for all fabric types (#100 sieve).
Water Permittivity (ASTM D4491)	0.02 sec ⁻¹ minimum
Grab Tensile Strength (ASTM D4632)	180 lbs. Minimum for extra strength fabric. 100 lbs minimum for standard strength fabric.
Grab Tensile Strength (ASTM D4632)	30% maximum
Ultraviolet Resistance (ASTM D4355)	70% minimum

- Support standard strength geotextiles with wire mesh, chicken wire, 2-inch x 2-inch wire, safety fence, or jute mesh to increase the strength of the geotextile. Silt fence materials are available that have synthetic mesh backing attached.
- Silt fence material shall contain ultraviolet ray inhibitors and stabilizers to provide a minimum of six months of expected usable construction life at a temperature range of 0°F to 120°F.
- One-hundred percent biodegradable silt fence is available that is strong, long lasting, and can be left in place after the project is completed, if permitted by the local jurisdiction.
- Refer to [Figure II-3.22: Silt Fence](#) for standard silt fence details. Include the following Standard Notes for silt fence on construction plans and specifications:
 1. The Contractor shall install and maintain temporary silt fences at the locations shown in the Plans.
 2. Construct silt fences in areas of clearing, grading, or drainage prior to starting those activities.

3. The silt fence shall have a 2-foot min. and a 2½-foot max. height above the original ground surface.
4. The geotextile fabric shall be sewn together at the point of manufacture to form fabric lengths as required. Locate all sewn seams at support posts. Alternatively, two sections of silt fence can be overlapped, provided that the overlap is long enough and that the adjacent silt fence sections are close enough together to prevent silt laden water from escaping through the fence at the overlap.
5. Attach the geotextile fabric on the up-slope side of the posts and secure with staples, wire, or in accordance with the manufacturer's recommendations. Attach the geotextile fabric to the posts in a manner that reduces the potential for tearing.
6. Support the geotextile fabric with wire or plastic mesh, dependent on the properties of the geotextile selected for use. If wire or plastic mesh is used, fasten the mesh securely to the up-slope side of the posts with the geotextile fabric up-slope of the mesh.
7. Mesh support, if used, shall consist of steel wire with a maximum mesh spacing of 2-inches, or a prefabricated polymeric mesh. The strength of the wire or polymeric mesh shall be equivalent to or greater than 180 lbs. grab tensile strength. The polymeric mesh must be as resistant to the same level of ultraviolet radiation as the geotextile fabric it supports.
8. Bury the bottom of the geotextile fabric 4-inches min. below the ground surface. Backfill and tamp soil in place over the buried portion of the geotextile fabric, so that no flow can pass beneath the silt fence and scouring cannot occur. When wire or polymeric back-up support mesh is used, the wire or polymeric mesh shall extend into the ground 3-inches min.
9. Drive or place the silt fence posts into the ground 18-inches min. A 12-inch min. depth is allowed if topsoil or other soft subgrade soil is not present and 18-inches cannot be reached. Increase fence post min. depths by 6 inches if the fence is located on slopes of 3H:1V or steeper and the slope is perpendicular to the fence. If required post depths cannot be obtained, the posts shall be adequately secured by bracing or guying to prevent overturning of the fence due to sediment loading.
10. Use wood, steel or equivalent posts. The spacing of the support posts shall be a maximum of 6-feet. Posts shall consist of either:
 - Wood with minimum dimensions of 2 inches by 2 inches by 3 feet. Wood shall be free of defects such as knots, splits, or gouges.
 - No. 6 steel rebar or larger.
 - ASTM A 120 steel pipe with a minimum diameter of 1-inch.
 - U, T, L, or C shape steel posts with a minimum weight of 1.35 lbs./ft.
 - Other steel posts having equivalent strength and bending resistance to the post sizes listed above.
11. Locate silt fences on contour as much as possible, except at the ends of the fence,

where the fence shall be turned uphill such that the silt fence captures the runoff water and prevents water from flowing around the end of the fence.

12. If the fence must cross contours, with the exception of the ends of the fence, place check dams perpendicular to the back of the fence to minimize concentrated flow and erosion. The slope of the fence line where contours must be crossed shall not be steeper than 3H:1V.
 - Check dams shall be approximately 1-foot deep at the back of the fence. Check dams shall be continued perpendicular to the fence at the same elevation until the top of the check dam intercepts the ground surface behind the fence.
 - Check dams shall consist of crushed surfacing base course, gravel backfill for walls, or shoulder ballast. Check dams shall be located every 10 feet along the fence where the fence must cross contours.
- Refer to [Figure II-3.23: Silt Fence Installation by Slicing Method](#) for slicing method details. The following are specifications for silt fence installation using the slicing method:
 1. The base of both end posts must be at least 2- to 4-inches above the top of the geotextile fabric on the middle posts for ditch checks to drain properly. Use a hand level or string level, if necessary, to mark base points before installation.
 2. Install posts 3- to 4-feet apart in critical retention areas and 6- to 7-feet apart in standard applications.
 3. Install posts 24-inches deep on the downstream side of the silt fence, and as close as possible to the geotextile fabric, enabling posts to support the geotextile fabric from upstream water pressure.
 4. Install posts with the nipples facing away from the geotextile fabric.
 5. Attach the geotextile fabric to each post with three ties, all spaced within the top 8-inches of the fabric. Attach each tie diagonally 45 degrees through the fabric, with each puncture at least 1-inch vertically apart. Each tie should be positioned to hang on a post nipple when tightening to prevent sagging.
 6. Wrap approximately 6-inches of the geotextile fabric around the end posts and secure with 3 ties.
 7. No more than 24-inches of a 36-inch geotextile fabric is allowed above ground level.
 8. Compact the soil immediately next to the geotextile fabric with the front wheel of the tractor, skid steer, or roller exerting at least 60 pounds per square inch. Compact the upstream side first and then each side twice for a total of four trips. Check and correct the silt fence installation for any deviation before compaction. Use a flat-bladed shovel to tuck the fabric deeper into the ground if necessary.

Figure II-3.23: Silt Fence Installation by Slicing Method

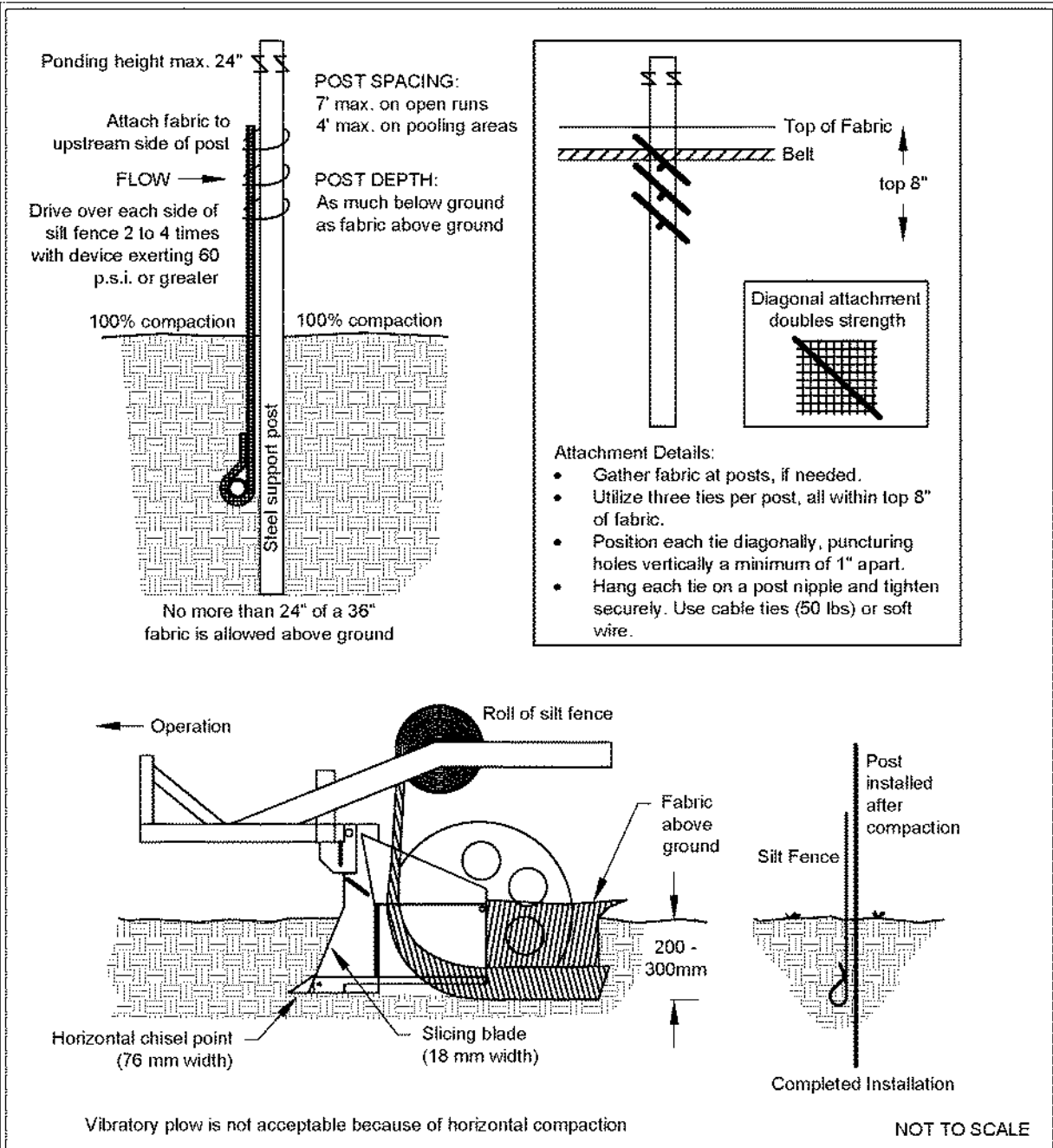

Silt Fence Installation by Slicing Method

Revised June 2016

Please see <http://www.ecy.wa.gov/copyright.html> for copyright notice including permissions, limitation of liability, and disclaimer.

Maintenance Standards

- Repair any damage immediately.
- Intercept and convey all evident concentrated flows uphill of the silt fence to a sediment trapping BMP.
- Check the uphill side of the silt fence for signs of the fence clogging and acting as a barrier to flow and then causing channelization of flows parallel to the fence. If this occurs, replace the fence and remove the trapped sediment.
- Remove sediment deposits when the deposit reaches approximately one-third the height of the silt fence, or install a second silt fence.
- Replace geotextile fabric that has deteriorated due to ultraviolet breakdown.

BMP C234: Vegetated Strip

Purpose

Vegetated strips reduce the transport of coarse sediment from a construction site by providing a physical barrier to sediment and reducing the runoff velocities of overland flow.

Conditions of Use

- Vegetated strips may be used downslope of all disturbed areas.
- Vegetated strips are not intended to treat concentrated flows, nor are they intended to treat substantial amounts of overland flow. Any concentrated flows must be conveyed through the drainage system to [BMP C241: Sediment Pond \(Temporary\)](#) or other sediment trapping BMP. The only circumstance in which overland flow can be treated solely by a vegetated strip, rather than by a sediment trapping BMP, is when the following criteria are met (see [Table II-3.12: Contributing Drainage Area for Vegetated Strips](#)):

Table II-3.12: Contributing Drainage Area for Vegetated Strips

Average Contributing Area Slope	Average Contributing Area Percent Slope	Max Contributing area Flowpath Length
1.5H : 1V or flatter	67% or flatter	100 feet
2H : 1V or flatter	50% or flatter	115 feet
4H : 1V or flatter	25% or flatter	150 feet
6H : 1V or flatter	16.7% or flatter	200 feet
10H : 1V or flatter	10% or flatter	250 feet

Maintenance Standards

- Monitor the spray field on a daily basis to ensure that over saturation of any portion of the field doesn't occur at any time. The presence of standing puddles of water or creation of concentrated flows visually signify that over saturation of the field has occurred.
- Monitor the vegetated spray field all the way down to the nearest surface water, or farthest spray area, to ensure that the water has not caused overland or concentrated flows, and has not created erosion around the spray nozzle(s).
- Do not exceed water quality standards for turbidity.
- Ecology recommends that a separate inspection log be developed, maintained and kept with the existing site logbook to aid the operator conducting inspections. This separate "Field Filtration Logbook" can also aid in demonstrating compliance with permit conditions.
- Inspect the spray nozzles daily, at a minimum, for leaks and plugging from sediment particles.
- If erosion, concentrated flows, or over saturation of the field occurs, rotate the use of branches or spray heads or move the branches to a new field location.
- Check all branches and the manifold for unintended leaks.

BMP C240: Sediment Trap

Purpose

A sediment trap is a small temporary ponding area with a gravel outlet used to collect and store sediment from sites during construction. Sediment traps, along with other perimeter controls, shall be installed before any land disturbance takes place in the drainage area.

Conditions of Use

- Sediment traps are intended for use on sites where the tributary drainage area is less than 3 acres, with no unusual drainage features, and a projected build-out time of six months or less. The sediment trap is a temporary measure (with a design life of approximately 6 months) and shall be maintained until the tributary area is permanently protected against erosion by vegetation and/or structures.
- Sediment traps are only effective in removing sediment down to about the medium silt size fraction. Runoff with sediment of finer grades (fine silt and clay) will pass through untreated, emphasizing the need to control erosion to the maximum extent first.
- Projects that are constructing permanent Flow Control BMPs, or Runoff Treatment BMPs that use ponding for treatment, may use the rough-graded or final-graded permanent BMP footprint for the temporary sediment trap. When permanent BMP footprints are used as temporary sediment traps, the surface area requirement of the sediment trap must be met. If the surface area requirement of the sediment trap is larger than the surface area of the permanent BMP, then the sediment trap shall be enlarged beyond the permanent BMP footprint to comply with the surface area requirement.

- A floating pond skimmer may be used for the sediment trap outlet if approved by the Local Permitting Authority.
- Sediment traps may not be feasible on utility projects due to the limited work space or the short-term nature of the work. Portable tanks may be used in place of sediment traps for utility projects.

Design and Installation Specifications

- See [Figure II-3.26: Cross Section of Sediment Trap](#) and [Figure II-3.27: Sediment Trap Outlet](#) for details.
- To determine the sediment trap geometry, first calculate the design surface area (SA) of the trap, measured at the invert of the weir. Use the following equation:

$$SA = FS(Q_2/V_s)$$

where

$Q_2 =$

- Option 1 - Single Event Hydrograph Method:

Q_2 = Peak volumetric flow rate calculated using a 10-minute time step from a Type 1A, 2-year, 24-hour frequency storm for the developed condition. The 10-year peak volumetric flow rate shall be used if the project size, expected timing and duration of construction, or downstream conditions warrant a higher level of protection.

- Option 2 - For construction sites that are less than 1 acre, the Rational Method may be used to determine Q_2 .

V_s = The settling velocity of the soil particle of interest. The 0.02 mm (medium silt) particle with an assumed density of 2.65 g/cm³ has been selected as the particle of interest and has a settling velocity (V_s) of 0.00096 ft/sec.

FS = A safety factor of 2 to account for non-ideal settling.

Therefore, the equation for computing sediment trap surface area becomes:

$$SA = 2 \times Q_2 / 0.00096$$

or

2080 square feet per cfs of inflow

- Sediment trap depth shall be 3.5 feet minimum from the bottom of the trap to the top of the overflow weir.
- To aid in determining sediment depth, all sediment traps shall have a staff gauge with a prominent mark 1-foot above the bottom of the trap.

- Design the discharge from the sediment trap by using the guidance for discharge from temporary sediment ponds in [BMP C241: Sediment Pond \(Temporary\)](#).

Maintenance Standards

- Sediment shall be removed from the trap when it reaches 1-foot in depth.
- Any damage to the trap embankments or slopes shall be repaired.

Figure II-3.26: Cross Section of Sediment Trap

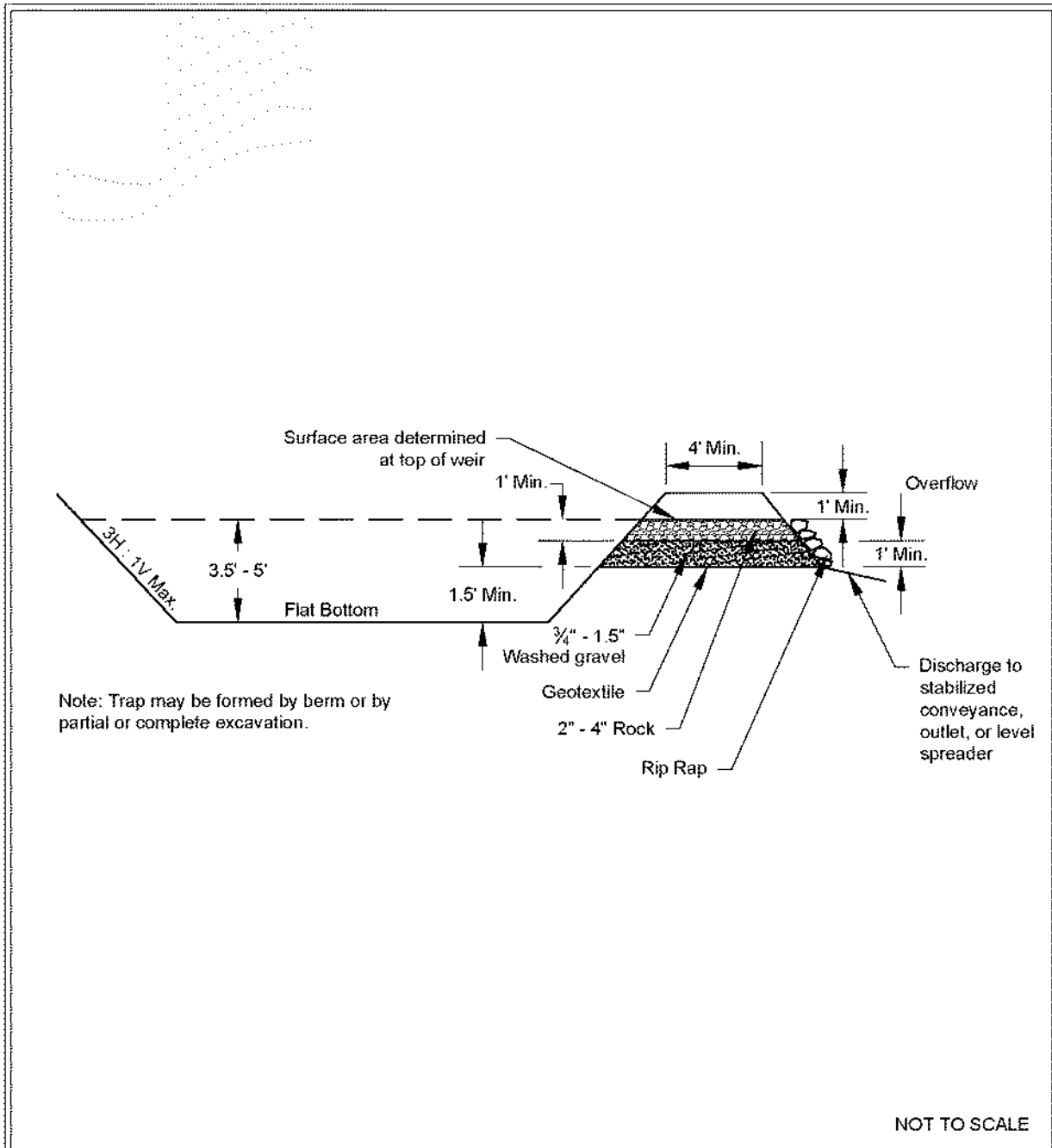

Cross Section of Sediment Trap

Revised June 2016

Please see <http://www.ecy.wa.gov/copyright.html> for copyright notice including permissions, limitation of liability, and disclaimer.

Figure II-3.27: Sediment Trap Outlet

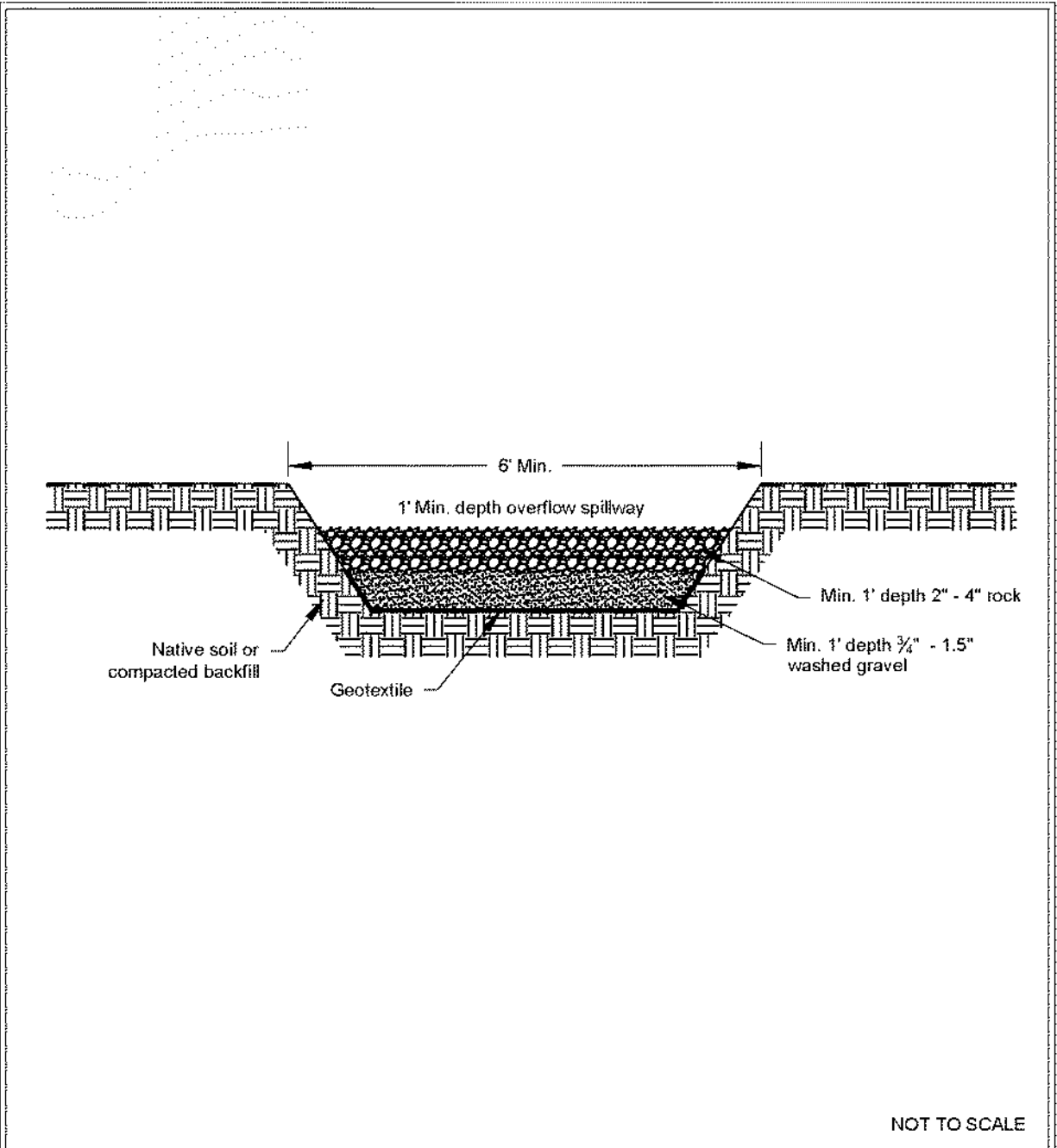

Sediment Trap Outlet

Revised June 2016

Please see <http://www.ecy.wa.gov/copyright.html> for copyright notice including permissions, limitation of liability, and disclaimer.