

PRCA20240398



City of Puyallup Development & Permitting Services ISSUED PERMIT	
Building	Planning
Engineering	Public Works
Fire	Traffic

**City of Puyallup  
Building  
REVIEWED  
FOR  
COMPLIANCE**

BSnowden  
09/05/2024  
9:31:44 AM

**SHOP DRAWING SUBMITTAL PACKAGE**

**EVELER PUYALLUP**

**Puyallup, Washington, United States**

Full-Sized legible color report is required to be provided by the Permittee on site for all Inspections

**QUOTE NUMBER**

Q-1053-R

**PREPARED FOR**

APOLLO SHEET METAL INC

05/29/2024

THIS BOOK IS PREPARED TO THE BEST OF OUR ABILITY AND IS OUR INTERPRETATION OF THE INFORMATION PERTAINING TO THIS JOB AS PRESENTED TO US

# Table of Contents

NT-1	1
NT-1 ADD AS REQUIRED	3
EW-1	4
EW-2	7
WH-1	14

City of Puyallup Development & Permitting Services ISSUED PERMIT	
Building	Planning
Engineering	Public Works
Fire	Traffic

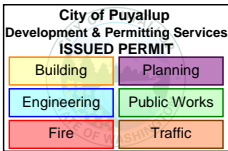

**SECTION**

# NT-1

**CONSIST OF:**

Orion 732043

# T5 Tank Order - Submittal Sheet

Job Name \_\_\_\_\_

Contractor Signature \_\_\_\_\_

Orion Representative \_\_\_\_\_

Approval Date \_\_\_\_\_

Quantity of Tanks \_\_\_\_\_

Contractor's P.O. No. \_\_\_\_\_

**Note:** All quotes/pricing received from this submittal expire 30 days from day of quote.

Please e-mail your signed and completed submittal, tank quote and purchase order to [oriontanks@wattswater.com](mailto:oriontanks@wattswater.com).

## T5 Cylindrical Bolted Top Tank

City of Puyallup Development & Permitting Services ISSUED PERMIT			
Building	Planning		
Engineering	Public Works		
Fire	Traffic		

### Specification

Orion T5 tank shall be cylindrical, seamless, stress and defect free, rotationally molded construction to uniform wall thickness from virgin PE resins conforming to ASTM D 1248, with **single FIP inlet with dip tube, outlet and vent as standard**. All penetrations shall be heat fused to tank wall. **Standard, non-load bearing, domed tank cover shall be bolted and gasketed to tank.**

### Connection Locations/Sizes (Choose One Location Only)

- Standard Locations:**  
Inlet-at 9:00 and centered 4" down from the top of the tank rim  
Outlet-at 3:00 and centered 4" down from the top of the tank rim
- Vent-at 6:00 & centered 3" down from top of tank rim

- Custom Locations: C & D Dimensions Required**  
Indicate desired locations in the small circles of the top-view diagram below.
- I-Inlet   O-Outlet   V-Vent

**Custom Sizes:**  
Indicate 2", 3", 4", or 6" in corresponding connection-type box.

Inlet    Outlet    Vent

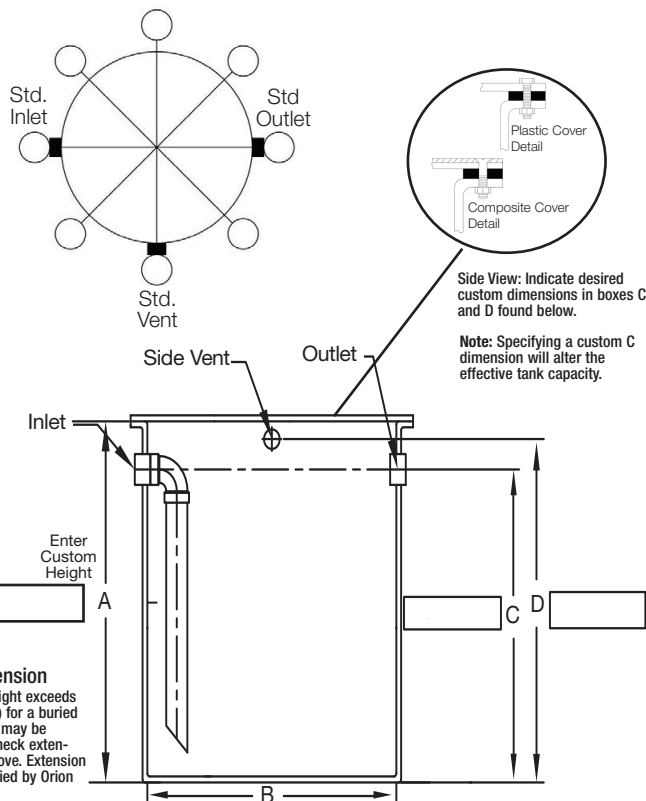

### Tank Size

Selection	Capacity USG Empty/Effective	Dimensions (in.)			Std. In/Out/Vent Size (in.)
Check One		Ht. (A)	Dia. (B)	Cover Dia.	
<input type="checkbox"/>	5/2	16	11	14	2/2/2
<input type="checkbox"/>	15/5	15.25	17.5	20.5	3/3/2
<input type="checkbox"/>	30/10	29.5	18	20.5	3/3/2
<input type="checkbox"/>	55/18	33	22	26	3/3/2
<input type="checkbox"/>	100/33	48	23.75	27.25	4/4/3
<input type="checkbox"/>	150/50	48.5	30	34.5	4/4/3
<input type="checkbox"/>	180/60	42.5	36.5	40	4/4/3
<input type="checkbox"/>	200/66	53.25	37.25	41.25	4/4/3
<input type="checkbox"/>	275/90	47	41.75	44.75	4/4/3
<input type="checkbox"/>	360/120	47.75	47.5	51.75	4/4/3
<input type="checkbox"/>	500/165	60	52	57	4/4/3
<input type="checkbox"/>	600/200	84	48	53	4/4/3
<input type="checkbox"/>	1200/400	84	69	74	4/4/3

### Connection, Cover, Support & Access Options

<input type="checkbox"/>	Optional No Hub Connections (FIP Std)	<input type="checkbox"/>	4" Cleanout Access
<input type="checkbox"/>	Optional Flanged Connections (FIP Std)	<input type="checkbox"/>	6" Cleanout Access
<input type="checkbox"/>	Tank Anchor Flange	<input type="checkbox"/>	12" Gamma Top Access
<input type="checkbox"/>	Reinforcing Anchor Flange	<input type="checkbox"/>	16" Gamma Top Access
<input type="checkbox"/>	Fiberglass Wrap*	<input type="checkbox"/>	20" x 3/4" Bolted Access
<input type="checkbox"/>	3/4" Plastic Cover	<input type="checkbox"/>	24" x 3/4" Bolted Access
<input type="checkbox"/>	1/4" Steel x 3/4" Plastic Cover (Not to be used in conjunction w/Access Options)	<input type="checkbox"/>	High Level Alarm
<input type="checkbox"/>		<input type="checkbox"/>	DualStrn/Lvl/Leak Alarm

**⚠ CALIFORNIA PROP 65 WARNING:** This product can expose you to chemicals including benzene which is known to the State of California to cause cancer and birth defects or other reproductive harm. For more information go to [www.P65Warnings.ca.gov](http://www.P65Warnings.ca.gov).

### NOTICE

The information contained herein is not intended to replace the full product installation and safety information available or the experience of a trained product installer. You are required to thoroughly read all installation instructions and product safety information before beginning the installation of this product.

Orion Fittings product specifications in U.S. customary units and metric are approximate and are provided for reference only. For precise measurements, please contact Orion Fittings Technical Service. Orion Fittings reserves the right to change or modify product design, construction, specifications, or materials without prior notice and without incurring any obligation to make such changes and modifications on Orion Fittings products previously or subsequently sold.

USA: T: (800) 334-6259 • [OrionFittings.com](http://OrionFittings.com)

Canada: T: (888) 208-8927 • F: (888) 479-2887 • [OrionFittings.ca](http://OrionFittings.ca)

Latin America: T: (52) 55-4122-0138 • [OrionFittings.com](http://OrionFittings.com)

**Note:** Tanks are made to ±0.25 in. tolerance.  
Please verify all selections with your local Orion rep - tanks and accessory equipment are non-cancelable & non-returnable.  
For technical advice contact: [oriontanks@wattswater.com](mailto:oriontanks@wattswater.com) (910) 865-7530



**A WATTS Brand**

City of Puyallup Development & Permitting Services ISSUED PERMIT	
Building	Planning
Engineering	Public Works
Fire	Traffic

**SECTION**

# NT-1 ADD AS REQUIRED

**CONSIST OF:**

- Orion 739302 \*(to be included)
- Orion 902184 \*(to be included)
- Orion 766207 \*(to be included)
- Orion 766208 \*(to be included)

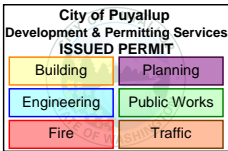

**SECTION**

# EW-1

---

**CONSIST OF:**

Bradley Corp S19-921H



A WATTS Brand

City of Puyallup Development & Permitting Services ISSUED PERMIT	
Building	Planning
Engineering	Public Works
Fire	Traffic

**S19-921H****On-Site® Gravity-Fed Eyewash**

- Complies with American National Standard Z358.1-2009
- Includes Wall-Mounting Bracket, Universal Identification Sign and Inspection Tag
- Full, One-Year Warranty — Water Preservative Not Included

**Specifications**

**S19-921H:** Self-contained eyewash unit is ideal anywhere water supply is not available. Flushes eyes for 15 minutes at a minimum of 0.4 gallons/minute by using only 7 gallons of water. Transparent tank assembly lets you see at a glance when it's time to clean or refill the tank. Sturdy pedestal with hinged eyewash tray pulls down in one quick motion. Removable tank is inverted onto pedestal, piercing a liner. Stainless steel clamps hold tank to pedestal. When arm is pulled down, water flow is activated.

Insulated heater jacket thermostatically controls water in weather conditions down to -10°F (-23.33°C). LED indicator lights ensure proper operation of heaters. GREEN means power is ON. AMBER means heaters are in operation. RED means unit has malfunctioned. This will automatically shut the unit off. Pulling front strap down and away from unit activates eyewash. Uses standard 120VAC power cord.

**On-Site Heated unit is not rated for outdoor use.**

**Construction**

Refillable eyewash tank fills to 7 gallons. Weighs 60 lbs. filled and 3.5 lbs. empty. Transparent tank made of impact resistant plastic, colored bright yellow for high visibility in emergency situations. Pedestal supports the eyewash tank and weighs 6 lbs. The yellow pedestal and black pull-down arm are made of impact and chemical resistant plastic. Wall bracket is stainless steel. Yellow insulated jacket made of 200 Denier foam-backed nylon oxford w/clear vinyl pocket for indicator light box. Silicone rubber pad heaters have PSA adhesive backing for ease of installation.

**Standard Equipment****Tank**

12"H x 22"W x 9"D tank made of transparent yellow polycarbonate.

**Pedestal**

13½"H x 22"W x 18½"D pedestal made of opaque yellow polypropylene, with a black polypropylene pull-down arm.

**Wall Bracket**

Stainless steel mounting bracket.

**Waste**

Nipple for ½" I.D. tube.

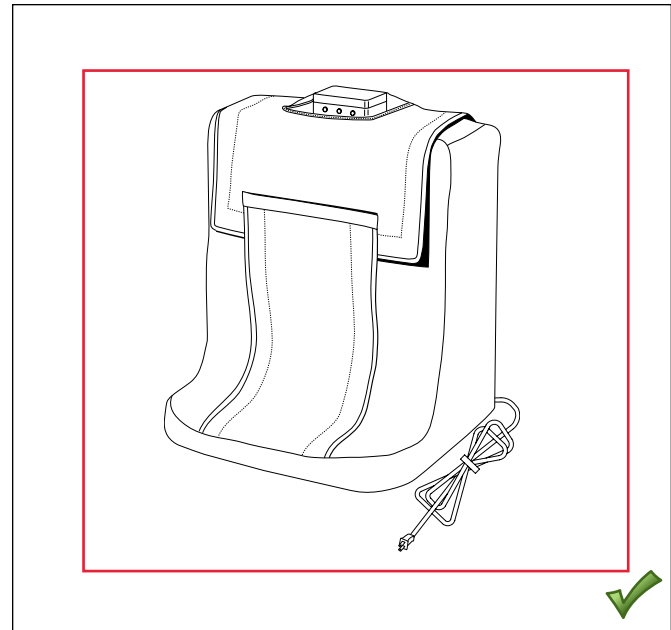
**Jacket**

High-visibility yellow, waterproof insulated jacket made of 200 Denier foam-backed nylon w/clear vinyl pocket. Includes 9' cord.

**Heaters**

121-watt tank heater and 60-watt tube heater made of silicone rubber with PSA adhesive backing.

**Dual Thermostat**

75°F +/- 5° normal operation thermostat in series with overheat protection of 90°F +/- 5° high limit, manually reset thermostat.

**Indicator Lights**

Green, Amber and Red LED indicator.



A WATTS Brand

# S19-921H

## On-Site® Gravity-Fed Eyewash

Model	Description
S19-921H	On-Site Heated Gravity Fed Eyewash

City of Puyallup Development & Permitting Services ISSUED PERMIT	
Building	Planning
Engineering	Public Works
Fire	Traffic

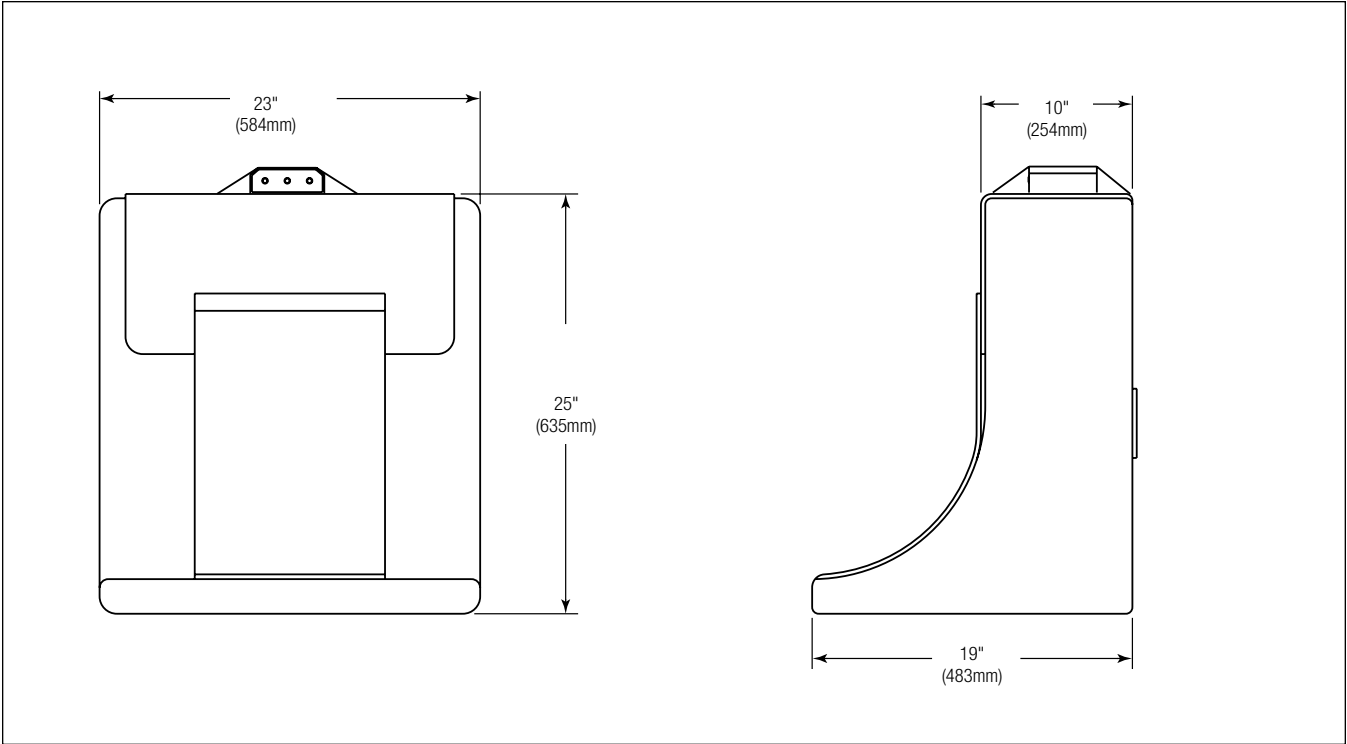

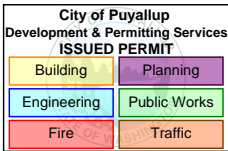

**SECTION**

# EW-2

**CONSIST OF:**

Bradley Corp S19314DCFW

Bradley Corp S19-2150



A WATTS Brand

# S19314PDCFW, S19314DCFW. S19314DCBF

## Combination Drench Shower and Halo™ Eye/Face Wash with Bowl Dust Cover

- Halo™ and SpinTec™ Deliver the Most Effective Shower and Eye/Face Washdown Coverage and Spray Pattern
- Exceeds ANSI/ISEA Z358.1 Specifications
- Industry's Only Self-Draining Design – The Aquaduct™
- Separate Supply and Waste Pipes – Meets CEN and Plumbing Requirements
- Ergonomic Hand Activation Eyewash Paddle – Easy to Reach from Any Direction
- Fully-Assembled and Factory-Tested Eye/Face Wash with Hinged Dust Covers
- Yellow Transparent Plastic and Stainless Steel Bowl Covers Available
- Barrier Free Option Available (S19314DCBF)
- Universal Identification Sign and Inspection Tag Included
- Classified by Underwriters Laboratories Inc. to ANSI/ISEA Z358.1.
- SpinTec showerheads are covered by one or more of the following patents: 8,113,446; 7,806,348; 8,490,895; D594,089; D669,555; Reg. Comm. Des. D001079560-0001. Other patents pending.
- Halo is Covered by One or More of the Following Patents: 9,700,484; 9,314,398; D662220; D673298; D662605; D685920; D662219; and D671228. Other Patents Pending.

### Specifications

Standard and Barrier-Free Combination Drench Shower Eye/Face Wash Units save space and fit easily into any work environment. Shower valve operates quickly by a pull rod with a triangular handle. Shower provides a superior washdown with a more even spray pattern. Halo eye/face wash, operated by an ergonomic, highly visible push handle, provides effective wash down coverage and spray pattern. Integral strainer reduces debris in the water and also prevents clogging.



*This plumbing fixture is not intended to dispense water for human consumption through drinking or for preparation of food or beverages.*

#### Pipe and Fittings

Piping to 1-1/4" NPT water supply inlet on unit. Piping to 1-1/4" NPT drain outlet. 1-1/4" piping assembly manufactured of one of the following materials:

- Galvanized steel with BradTect® safety yellow coating

#### Ball Valve

1" shower ball valve and ½" stay-open eye/face wash valve manufactured of the following materials and supplied with type 304 stainless steel pull rod and handle:

- Chrome-plated brass

#### SpinTec™ Showerhead

Standard showerhead is 3.1" (78.7mm) diameter highly visible yellow impact-resistant plastic. SpinTec drench showerhead features integral 22 GPM (83.3 L) flow control (exceeds minimum water flow of 20 GPM (75.7L) at 30 PSI (2.0 bar)), conserving water and helping to accurately size your tepid water system.

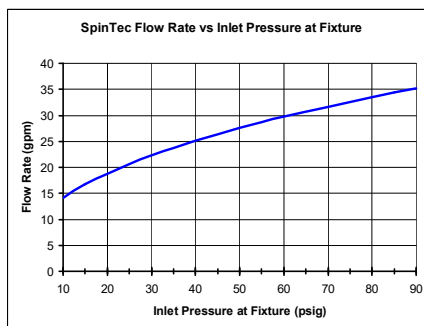

#### Eye/Face Wash

The Halo eye/face wash system offers a high performance rinsing platform that provides rapid relief to an individual's eyes and face that have been injured by chemicals or particulate. This system provides the most complete face wash available in the market. The eye/face wash includes an integral 5.1 GPM (19.2 L) flow control, providing water at a safe velocity while maintaining its effectiveness (exceeds minimum water flow of 3.0 GPM (11.4 L) at 30 PSI (2.0 bar)). The eye/face wash is protected by flip open dust covers that open when the product is activated by type 304 stainless steel push handle. Safe, steady water flow under varying water supply conditions from 30–90 PSI (2.0-6.1 bar) is assured by integral flow control in the sprayhead assembly. Sprayheads are made from an impact resistant ABS plastic.

#### Bowl

Bowl is constructed of yellow impact-resistant plastic (S19314PDCFW) or Type 304 corrosion-resistant stainless steel (S19314DCFW, S19314DCBF).

#### Bowl Dust Cover

Dust cover is constructed of transparent yellow impact-resistant plastic (S19314PDCFW) or Type 304 corrosion-resistant stainless steel (S19314DCFW, S19314DCBF).



*For information on all available S19314 models, please see tech data document Bradley\_SafetyCombi\_S19314Series.*

Model	Description
S19314PDCFW	Halo eye/face wash, plastic showerhead & bowl w/ dust cover
S19314DCFW	Halo eye/face wash, plastic showerhead, stainless steel bowl & hinged dust cover
S19314DCBF	Halo eye/face wash, barrier-free, plastic showerhead, stainless steel bowl w/ dust cover

### Tepid Water Options

[Navigator S19-2150 EFX20](#)  
Emergency Thematic Mixing Valve

[Keltech SNA-Series](#)  
Tankless Water Heater

NAVIGATOR

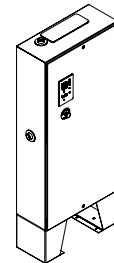
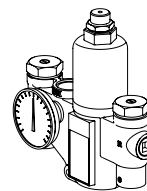

Satisfies ANSI/ISEA Z358.1 tepid water requirements.

© 2024 Bradley

P.O. Box 309, Menomonee Falls, WI 53052-0309  
800 BRADLEY (800 272 3539)

+1 262 251 6000  
bradleycorp.com



# S19314PDCFW, S19314DCFW. S19314DCBF

## Combination Drench Shower and Halo™ Eye/Face Wash with Bowl Dust Cover

### S19314 shown with Dust Cover

Drawing depicts Eyewash. Eye/Face Wash dimensions are the same.

City of Puyallup Development & Permitting Services ISSUED PERMIT	
Building	Planning
Engineering	Public Works
Fire	Traffic

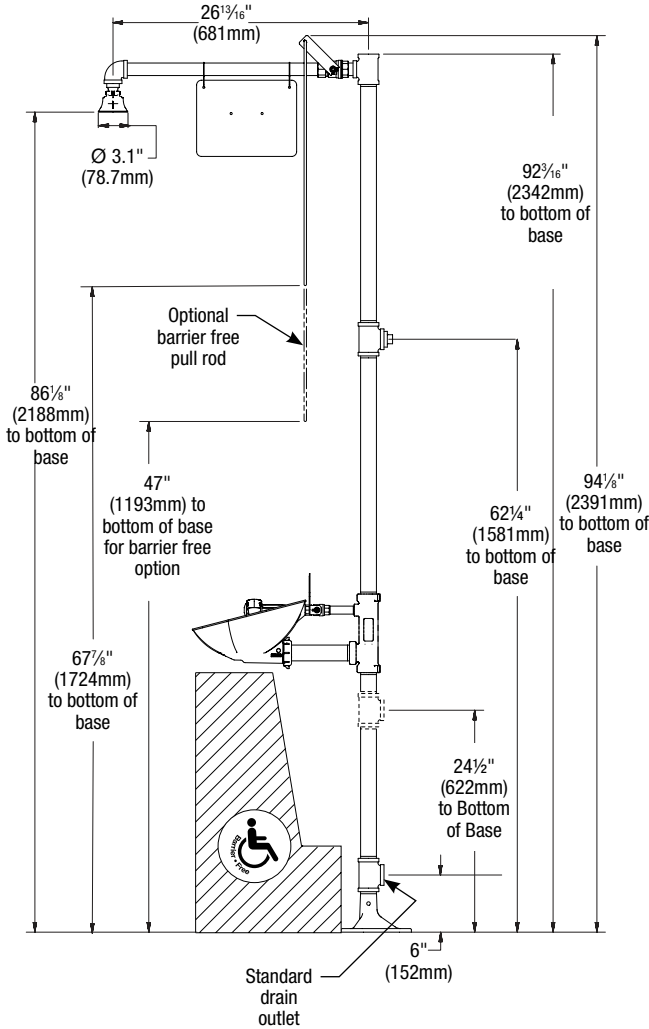

Eye/Face Wash Bowl

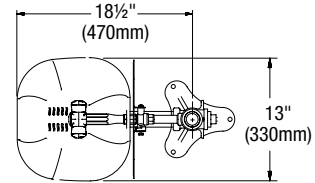

Dust Cover

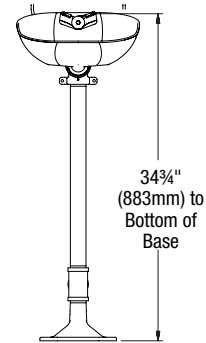
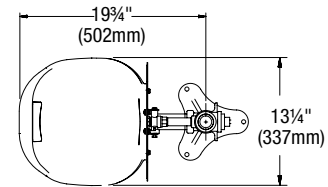

All dimensions assume standard thread engagement. Variations in manufacturing allow for +/- 1/8" (3mm) per threaded joint. To find the tolerance of a dimension, add the number of thread joints across the length of the dimension and multiply it by 1/8" (3mm).



# S19-2150 (EFX20)

## Emergency Fixture Thermostatic Mixing Valve

- Exceeds ANSI Z358.1
- ASSE 1071 Certified
- Reliable Liquid-Filled Thermostat with 10-Year Warranty
- Integral Strainer Checkstops on Inlets
- Adjustable Set Point within Temperature Range
- Accurate Temperature Control to within ±3° F
- Built-in Cold Water Bypass, Assuring Cold Flow
- Positive Shutoff of Hot Supply When Cold Supply is Lost
- Easy Installation and Serviceability
- Dirt and Lime Resistant
- Dial Thermometer
- Factory Assembled and Tested
- Universal Mounting Capability
- Cabinet Features:
  - 18 Gauge Body & Door
  - Left-Hand Hinge
  - Cylinder Lock
  - Inlet/Outlet Knock-Out Holes for Mounting Flexibility
  - Stainless Steel or Baked White Enamel Finishes
  - Surface-Mounted or Recessed Style

### Valve Specifications

**Maximum Operating Pressure**  
125 PSI (860 kPa)

**Maximum Inlet Temperature**  
180° F (82° C)

**Recommended Inlet Temperature**  
120° F (49° C) – 140° F (60° C)

**Temperature Range** **Set Point**  
**Std.** 65° F (18° C) to 90° F (32° C) 85° F (29° C)

### Flow Capacities – GPM

Model	Min. Flow	Pressure Drop – PSI						
		5	10	15	20	30	45	60
<b>S19-2150</b>	3.0	6.8	15.2	20.1	23.8	30.3	36.8	42.5

Minimum cold water bypass at 30 PSID: 16.9 GPM

### Flow Capacities – L/Min

Model	Min. Flow	Pressure Drop – Bar						
		.5	1.0	1.5	2.0	2.5	3.0	4.0
<b>S19-2150</b>	11.4	25.7	57.5	76.1	90.1	114.7	139.3	160.9

Minimum cold water bypass at 2.1 Bar: 64.0 L/Min

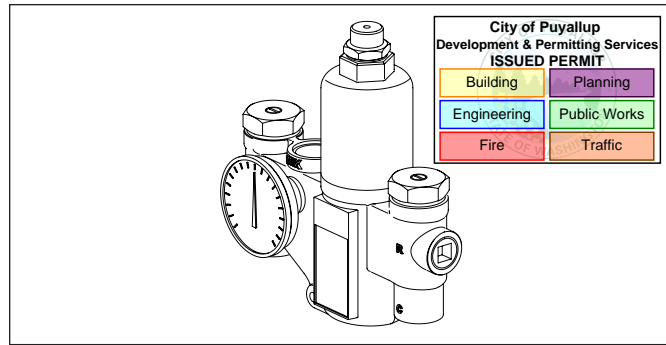

Valve Model	Description
<input checked="" type="checkbox"/> <b>S19-2150</b>	Emergency Fixture Thermostatic Mixing Valve

Configurable Valve Model (select one)	Description
<input checked="" type="checkbox"/> <b>EFX20</b>	EFX20 Thermostatic Mixing Valve with Options
<input type="checkbox"/> <b>CAB-EFX20</b>	EFX20 Thermostatic Mixing Valve <b>Cabinet Only</b>

Optional Valve Selections	
<b>Finish</b>	
<input checked="" type="checkbox"/> <b>R</b>	Rough Brass (standard)
<input type="checkbox"/> <b>C</b>	Chrome Plated

<b>Bracket</b>	
<input type="checkbox"/> <b>B</b>	Wall Mounting Bracket
<input type="checkbox"/> <b>0</b>	None

<b>Piped Assembly</b>	
<input type="checkbox"/> <b>P</b>	Piped Assembly with Inlet and Outlet Shutoff
<input type="checkbox"/> <b>N*</b>	Piped Assembly only
<input type="checkbox"/> <b>0</b>	None

Optional Cabinet Selections	
<b>Cabinets (includes bracket)</b>	
<input type="checkbox"/> <b>SS</b>	Surface Mount Stainless Steel
<input type="checkbox"/> <b>RS</b>	Recessed Stainless Steel
<input type="checkbox"/> <b>SE</b>	Surface Mount White Enamel
<input type="checkbox"/> <b>RE</b>	Recessed White Enamel
<input type="checkbox"/> <b>0</b>	None

<b>Window</b>	
<input type="checkbox"/> <b>W</b>	Plexi-Glass Window in Door
<input type="checkbox"/> <b>0</b>	None

\*Requires cabinet selection

### Product Compliance

Listed by IAPMO R&T to

- ASSE 1071
- Uniform Plumbing Code (UPC)
- National Plumbing Code of Canada
- International Plumbing Code (IPC)



Listed by ASSE International to

- ASSE 1071

This plumbing fixture is not intended to dispense water for human consumption through drinking or for preparation of food or beverages.

© 2019 Bradley

P.O. Box 309, Menomonee Falls, WI 53052-0309  
 800 BRADLEY (800 272 3539) +1 262 251 6000  
 bradleycorp.com

Engineer's Approval \_\_\_\_\_

Page 1 of 4 10/1/2019  
 This information is subject to change without notice.  
 Bradley\_TMV\_Emergency\_EFX20



**S19-2150 (EFX20)**

**Emergency Fixture Thermostatic Mixing Valve**

**Recirculation Diagram**

(mm)

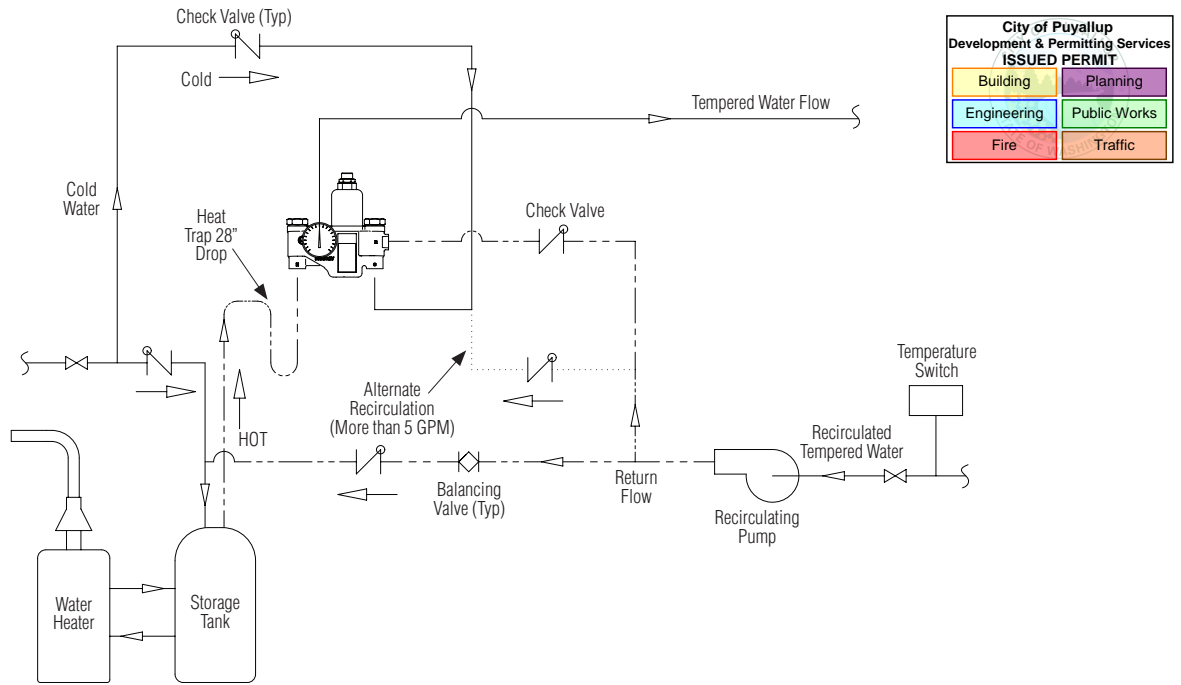

**Dimensions**

Model	A	B	C	D	E	F	G	H	X <sup>NPT</sup>	Y <sup>NPT</sup>	Z <sup>NPT</sup>
S19-2150	7" (178)	2" (51)	3-1/8" (79)	5-1/4" (133)	9-5/8" (244)	14" (356)	2-3/4" (70)	9-3/16" (230)	3/4"	1"	3/4"

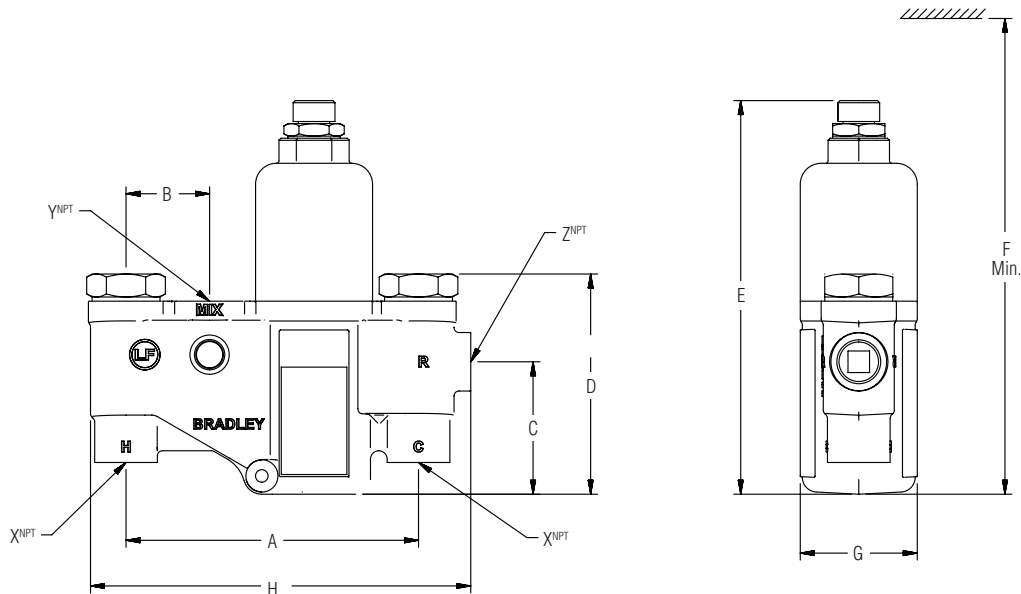

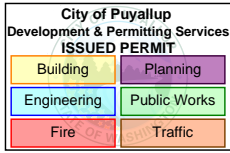

# S19-2150 (EFX20)

## Emergency Fixture Thermostatic Mixing Valve

### Dimensions — Surface-Mounted Cabinet

(mm)

Side View

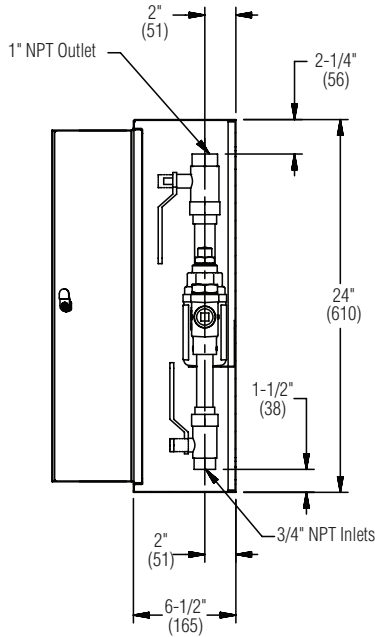

Front View

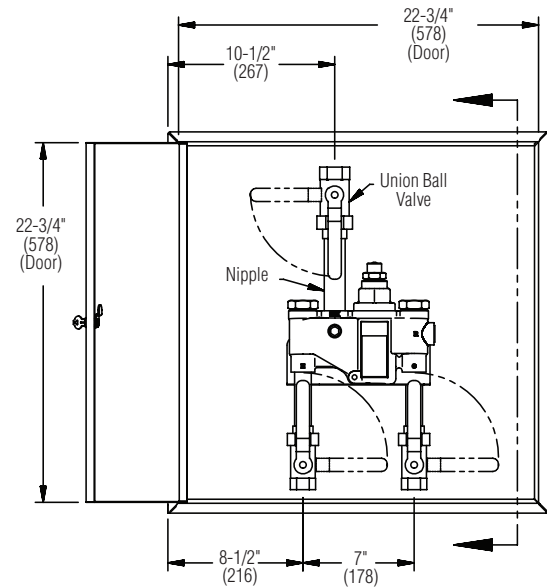

Bottom View

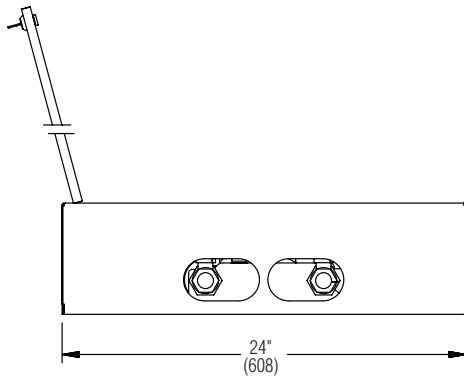

Back View

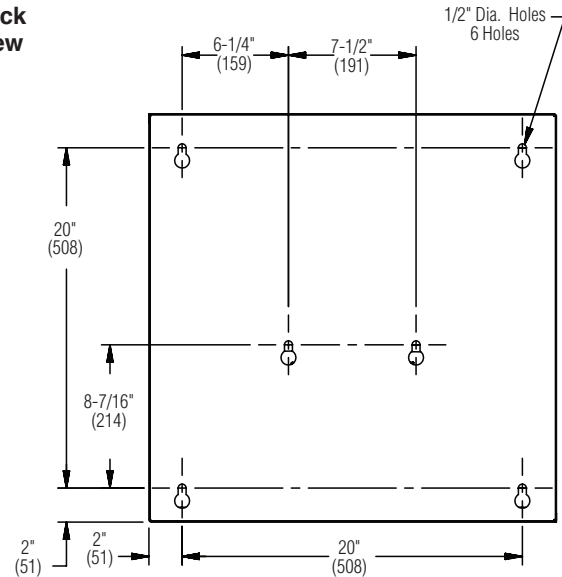



City of Puyallup Development & Permitting Services ISSUED PERMIT	
Building	Planning
Engineering	Public Works
Fire	Traffic

# S19-2150 (EFX20)

## Emergency Fixture Thermostatic Mixing Valve

### Dimensions — Recessed Cabinet

(mm)

**Side View**

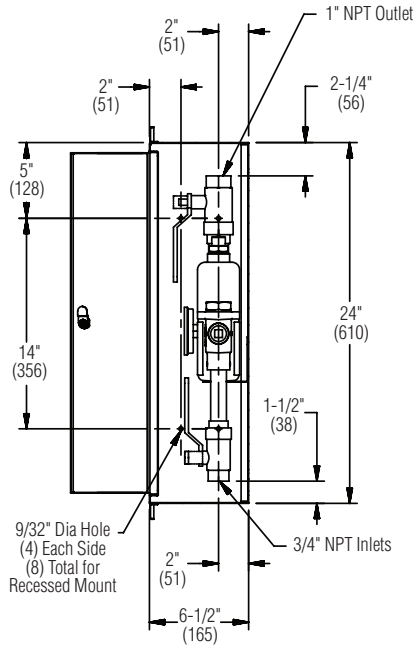

**Front View**

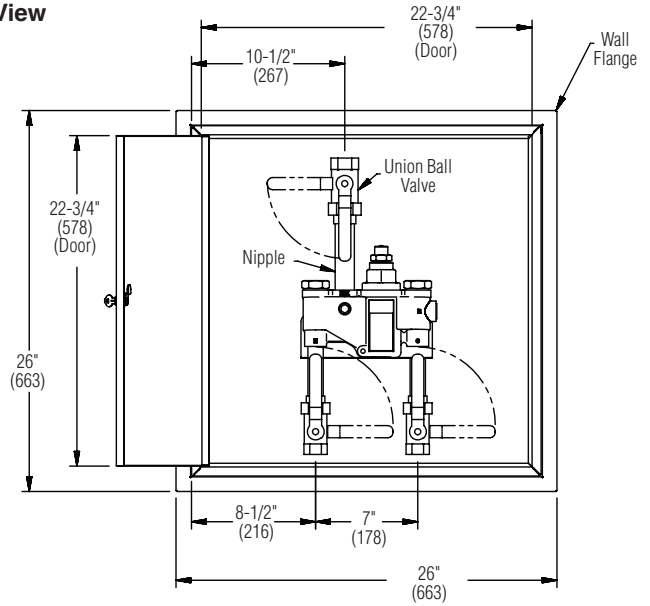

**Bottom View**

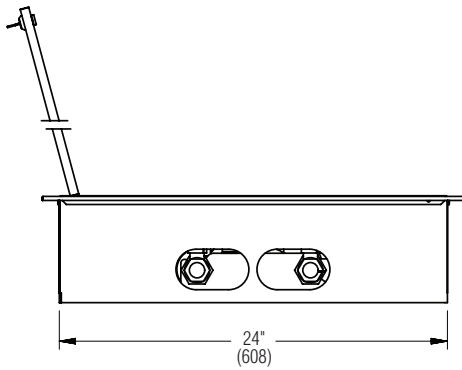

**Back View**

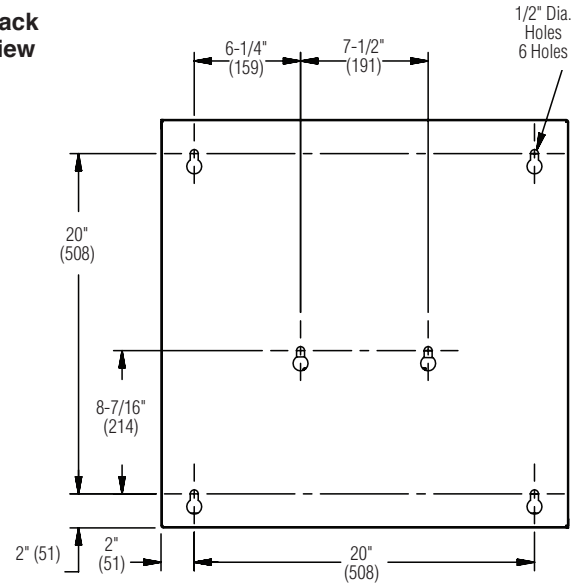

City of Puyallup Development & Permitting Services ISSUED PERMIT	
Building	Planning
Engineering	Public Works
Fire	Traffic

**SECTION**

# WH-1

**CONSIST OF:**

A.O. Smith BTF-80

## CONSERVATIONIST® POWER VENT

### APPROVAL RATINGS AND CERTIFICATION

- All models comply with: ANSI Z21.10.3/CSA 4.3 and ASHRAE/IES 90.1 – 2004
- Meets Texas and other low NOx areas requiring 40ng/j
- All models are approved for use in combined appliance applications.

### CFC-FREE FOAM INSULATION

- Minimizes radiant heat loss.

### DIP TUBE

- Carries inlet water deep into tank.

### HOT SURFACE IGNITION

- Has a solid state ignition surface that does not flutter or blow out.
- Provides increased reliability and efficiency over spark ignition systems. Eliminates the pilot and saves energy.

### USER-FRIENDLY

- State-of-the-art electronic gas control provides more precise temperature control.
- LED control light displays operation status and diagnostics information.

### ENHANCED-FLOW BRASS DRAIN VALVE

- Have a solid brass, tamper resistant, enhanced-flow, ball type, drain valve.
- Uses a standard female hose fitting that allows for fast and easy draining during maintenance.
- Designed for easy operation, this valve includes an integral screwdriver slot that features a ¼ turn (open/close) radius, which not only permits full straight-through water flow but also a quick and positive shut off.

### BLUE DIAMOND® GLASS COATING

- Provides superior corrosion resistance compared to the industry-standard glasslining.

### STANDARDS

- Design-certified by CSA International, according to ANZI Z21.10.3 - CSA 4.3 standards governing storage-type water heaters.
- Meets the thermal efficiency and standby loss requirements of the U.S. Department of Energy and current edition of ASHRAE/IESNA 90.1.

### POWERED VENTING

- Provides more venting flexibility and savings. A new quiet blower allows exhaust venting through the roof or sidewall with plastic pipe such as PVC, CPVC, ABS, and polypropylene.
- Up to 125 equivalent feet of pipe make installation easy in any situation.
- BTF-80 is a Category 3 (positive pressure non-condensing) appliance.

### ANODES

- Tank-mounted, screw-in magnesium anodes for longer tank life.

### HIGH INPUT

- 76,000 BTU input assures plenty of hot water is available by providing faster recovery rates and higher first hour draws.

### BURNER

- High input, multiport burner for improved combustion efficiency and low NOx.

### BUILT-IN CONDENSATE FITTING

- A condensate management coupling that attaches vent pipe to the blower is included.

### INSTALLED TEMPERATURE & PRESSURE RELIEF VALVE

- Factory installed and matched to the heater. (Specify if your local code requires a special T&P).

### MAXIMUM HYDROSTATIC WORKING PRESSURE 150 PSI

### 3-YEAR LIMITED TANK / 1-YEAR LIMITED PARTS WARRANTY

- For complete warranty information, consult written warranty or contact A. O. Smith.



Low Lead Content





# Commercial Gas Water Heaters

City of Puyallup Development & Permitting Services ISSUED PERMIT			
Building	Planning	Engineering	Public Works
Fire	Traffic		

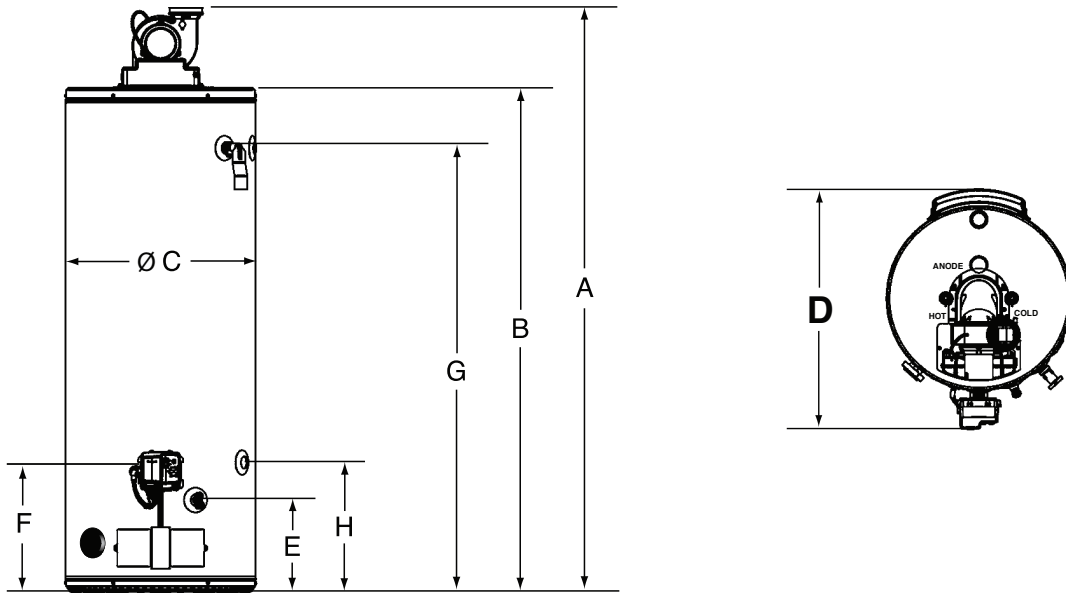

## DIMENSIONS

Model Number	Units	A	B	C	D	E	F	G	H	Water Connections	Gas Connection	Approx. Shipping Weight
BTF-80	Inches	70-5/8	61-1/4	26	33-1/8	11	13-1/4	53	15-1/4	3/4" NPT	1/2" NPT	277 lbs
	cm	179	156	66	84	28	36	135	39			126 kg

Dimensions and specifications subject to change without notice in accordance with our policy of continuous product improvement.

## RECOVERY CAPACITIES

U.S. GALLONS/HR. AND LITRES/HR. AT TEMPERATURE RISE INDICATED

Model Number	Input		Approx. Capacity		°F	30°F	40°F	50°F	60°F	70°F	80°F	90°F	100°F	110°F	120°F	130°F	140°F
	Btuh	kW	U.S. Gals.	Litres	°C	17°C	22°C	28°C	33°C	39°C	44°C	50°C	56°C	61°C	67°C	72°C	78°C
BTF-80	76,000		75		GPH	246	185	148	123	106	92	82	74	67	62	57	52
		22.3		280	LPH	932	699	559	466	400	350	311	280	254	233	215	200

Available in LP (Propane) gas

Can be installed up to 10,100 feet without alteration.

## SAMPLE SPECIFICATION

Water Heater(s) shall be power vent model no. \_\_\_\_\_ as manufactured by A. O. Smith or an approved equal. Heater(s) shall be internally glasslined and gas-fired, equipped to burn \_\_\_\_\_ gas, and design-certified to the latest ANSI Standard by the CSA International. Rating of \_\_\_\_\_ Gallons and an input rating of \_\_\_\_\_ BTU/HR with a recovery capacity of \_\_\_\_\_ GPH at 100° F. Waters heaters must be certified for power venting applications using standard PVC, class 160, schedule 40, ABS or CPVC vent piping. The water heater shall include a 6' plug-in cord and provision for direct connection to standard electrical conduit. Blower shall include pressure switches which will shut down power to the burner in case of vent system failure due to down drafts or vent blockage. Heater shall have a maximum working pressure of 150 psi, and a nominal storage tank capacity of \_\_\_\_\_ gallons with a 3/4" relief valve opening. Heater(s) shall also be equipped with an automatic shut off device to shut off entire gas supply in event of excessive temperature in tank. Outer jacket shall have a baked enamel finish.

For technical information, call 800-527-1953. A. O. Smith Corporation reserves the right to make product changes or improvements without prior notice.



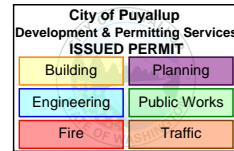

## VCD-40 Extruded Airfoil Blade Volume Control Damper

### APPLICATION & DESIGN

The VCD-40 is a low leakage high performance control damper with extruded aluminum airfoil blades. The blades are completely contained within the frame allowing the damper to be directly mounted to a louver, filter frame or similar application with no blade interference. Smooth profile extruded aluminum airfoil blades insure the lowest resistance to airflow in HVAC systems.

### DAMPER RATINGS

**Pressure:** Up to 6 in. wg - pressure differential  
**Velocity:** Up to 6,000 ft/min  
**Leakage:** 4 CFM @ 4 in. wg or  
 2 CFM @ 1 in. wg  
**Temperature:** Up to 250 F

### PRODUCT DETAILS

**Frame Type:** Channel  
**Frame Thickness:** 0.125 in.  
**Material:** Aluminum  
**Blade Type:** Airfoil  
**Blade Action:** Opposed  
**Blade Seal:** TPE  
**Axle/Linkage Material:** Steel  
**Axle Bearings:** Synthetic  
**Jamb Seal Material:** Stainless Steel  
**Damper Temp. Rating:** 180 F  
**Jackshafting:** No Preference  
**Actuator Sizing:** Default SqFt  
**Multi-Section Fastening:** Standard  
**Sizing:** Nominal

### ACTUATOR INFORMATION

**Actuator Type:** 120 VAC  
**Operating Mode:** TwoPosition  
**Actuator Operation:** Spring Return  
**Fail Position:** Open  
**Auxiliary Switches:** Yes

### OPTIONS & ACCESSORIES

**Union Label:** No Preference

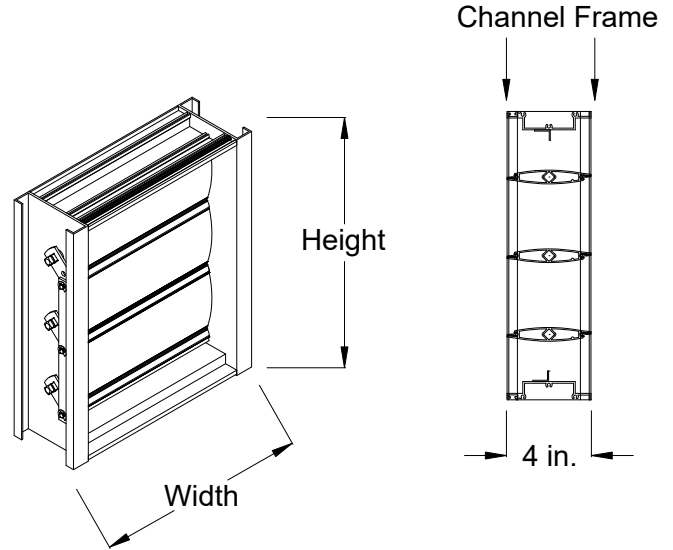

- This drawing shows a general damper configuration and is not intended to depict the exact configuration of all dampers in this submittal.
- Width and height furnished approximately 0.250 in. undersize.
  - Dampers with an entered height of 6 in. will be undersized 1/8 in.
- Factory supplied actuators are sized for 1,500 fpm and a fully-closed differential pressure of 2 in. wc. Contact factory for actuator sizing on applications exceeding those levels.
- Dampers with more than one section wide will be furnished with a single OCI device per row when the blade indicator option is selected.
- Installation instructions available at [www.greenheck.com](http://www.greenheck.com).

### CODES APPROVED

IECC (International Energy Conservation Code) compliant  
 The AMCA Certified Ratings Seal applies to Air Performance

### SUMMARY

ID #	Tag	Qty	Width	Height	Configuration			
6-1		2	12.000 in.	16.000 in.	Drive Arrangement: Drive- CC-11-1FER-0	Actuator Mounting: External Kit	Actuator Location: Right Side	Actuator Qty: 1
					Actuator Mfr: Belimo	Actuator Model: TFB120-S	Act. Orientation: N/A	

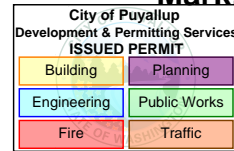

## VCD-40 Extruded Airfoil Blade Volume Control Damper

### APPLICATION & DESIGN

The VCD-40 is a low leakage high performance control damper with extruded aluminum airfoil blades. The blades are completely contained within the frame allowing the damper to be directly mounted to a louver, filter frame or similar application with no blade interference. Smooth profile extruded aluminum airfoil blades insure the lowest resistance to airflow in HVAC systems.

### DAMPER RATINGS

**Pressure:** Up to 6 in. wg - pressure differential  
**Velocity:** Up to 6,000 ft/min  
**Leakage:** 4 CFM @ 4 in. wg or  
 2 CFM @ 1 in. wg  
**Temperature:** Up to 250 F

### PRODUCT DETAILS

**Frame Type:** Channel  
**Frame Thickness:** 0.125 in.  
**Material:** Aluminum  
**Blade Type:** Airfoil  
**Blade Action:** Opposed  
**Blade Seal:** TPE  
**Axle/Linkage Material:** Steel  
**Axle Bearings:** Synthetic  
**Jamb Seal Material:** Stainless Steel  
**Damper Temp. Rating:** 180 F  
**Jackshafting:** No Preference  
**Actuator Sizing:** Default SqFt  
**Multi-Section Fastening:** Standard  
**Sizing:** Nominal

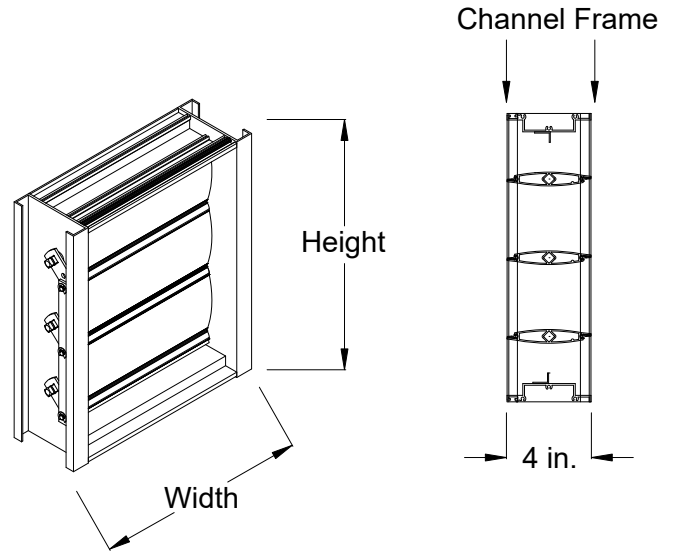

- This drawing shows a general damper configuration and is not intended to depict the exact configuration of all dampers in this submittal.
- Width and height furnished approximately 0.250 in. undersize.
  - Dampers with an entered height of 6 in. will be undersized 1/8 in.
- Factory supplied actuators are sized for 1,500 fpm and a fully-closed differential pressure of 2 in. wc. Contact factory for actuator sizing on applications exceeding those levels.
- Dampers with more than one section wide will be furnished with a single OCI device per row when the blade indicator option is selected.
- Installation instructions available at [www.greenheck.com](http://www.greenheck.com).

### ACTUATOR INFORMATION

**Actuator Type:** 120 VAC  
**Operating Mode:** TwoPosition  
**Actuator Operation:** Spring Return  
**Fail Position:** Open  
**Auxiliary Switches:** Yes

### OPTIONS & ACCESSORIES

**Union Label:** No Preference

### CODES APPROVED

IECC (International Energy Conservation Code) compliant  
 The AMCA Certified Ratings Seal applies to Air Performance

### SUMMARY

ID #	Tag	Qty	Width	Height	Configuration			
7-1		1	12.000 in.	16.000 in.	Drive Arrangement: Drive- CC-11-1FER-0	Actuator Mounting: External Kit	Actuator Location: Right Side	Actuator Qty: 1
					Actuator Mfr: Belimo	Actuator Model: TFB120-S	Act. Orientation: N/A	



---

Damper Drive Arrangements Job Summary -Start-

---

Drive Arrangement: Drive-CC-11-1FER-0

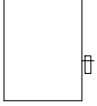

---

Damper Drive Arrangements Job Summary -End-

---

# Drive Arrangement Definition

Actuator driven dampers are supplied with a drive arrangement code that helps describe the configuration of the damper. The following breaks down what each number and letter represents.

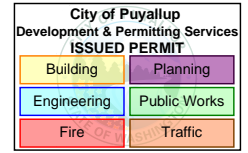

**22-2FER-2**



- ① Number of sections wide
- ② Number of sections high
- ③ Number of actuators or manual operators (such as quadrants, pull chain, etc.)
- ④ Who supplies the actuators or manual operators  
F - Factory  
C - Customer Supplied (field mounted)
- ⑤ Actuator or manual operators mounting  
E - External  
I - Internal  
B - Both internal and external
- ⑥ Actuator or manual operators location  
L - Left hand drive  
R - Right hand drive  
B - Both right and left
- ⑦ Number of jackshafts

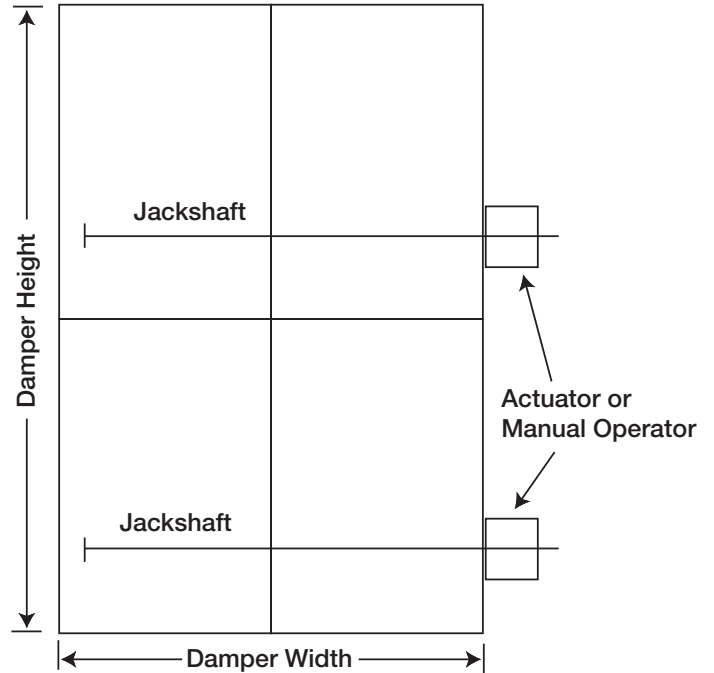

Each damper is supplied with a Drive Arrangement Prefix to help describe its construction. See the following examples:

Model	Drive Arrangement Prefix
AMD series, AMD-TD series	AMD
FBH & FBV	FB
DFD-210; DFDAF-310, DFDAF-330; SEDFD-210 FSD, OFSD, CFSD, SMD, SEFSD, SSFSD, SESMD, SSSMD series (except vertical blade models)	MLS
ICD series, MBD-15 & VCD series (except vertical blade models)	CC
FSD-311V, SMD-301V, VCD-xxV	VB

# TFB120-S - Damper Actuator

## On/Off, Spring Return, 100 to 240 VAC

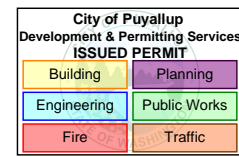

Technical Data	
Power Supply	100...240 VAC, -15% / +10%, 50/60 Hz
Power Consumption Running	2.5 W
Power Consumption Holding	1.3 W
Transformer Sizing	5 VA
Shaft Diameter	1/4" to 1/2" round, centers on 1/2"
Electrical Connection	(2) 3ft [1m], 18 GA appliance cables with 1/2" conduit connectors
Overload Protection	electronic throughout 0° to 95° rotation
Electrical Protection	actuators are double insulated
Angle of Rotation	Max. 95°, adjustable with mechanical stop
Torque motor	22 in-lbs [2.5 Nm]
Direction of Rotation (Motor)	reversible with CW/CCW mounting
Direction of Rotation (Fail-Safe)	reversible with CW/CCW mounting
Position Indication	visual indicator, 0° to 95° (0° is full spring return position)
Running Time (Motor)	<75 sec
Running Time (Fail-Safe)	<25 sec @ -4°F to 122°F [-20°C to 50°C], <60 sec @ -22°F [-30°C]
Ambient Humidity	max. 95% RH non-condensing
Ambient Temperature	-22...122 °F [-30...50 °C]
Storage Temperature	-40...176 °F [-40...80 °C]
Degree of Protection	IP42, NEMA 2, UL Enclosure Type 2
Housing Material	UL94-5VA
Agency Listings†	cULus acc. to UL60730-1A/-2-14, CAN/CSA E60730-1:02, CE acc. to 2004/108/EC and 2006/95/EC
Noise Level (Motor)	<50 dB (A)
Noise Level (Fail-Safe)	<62 dB (A)
Servicing	maintenance free
Quality Standard	ISO 9001
Weight	1.83 lb [0.83 kg]
Auxilliary switch	1 x SPDT, 3A resistive (0.5A inductive) @ 250 VAC, adjustable 0° to 95°

†Rated Impulse Voltage 4kV, Type of Action 1.AA.B, Control Pollution Degree 3.

**Torque min. 22 in-lb, for control of air dampers.**

### Application

For On/Off, fail-safe control of dampers in HVAC systems. Actuator sizing should be done in accordance with the damper manufacturer's specifications. Control is On/Off from an auxiliary contact, or a manual switch. The actuator is mounted directly to a damper shaft from 1/4" up to 1/2" in diameter by means of its universal clamp, 1/2" shaft centered at delivery. A crank arm and several mounting brackets are available for applications where the actuator cannot be direct coupled to the damper shaft.

### Operation

The TF series actuators provide true spring return operation for reliable fail-safe application and positive close off on air tight dampers. The spring return system provides consistent torque to the damper with, and without, power applied to the actuator. The TF series provides 95° of rotation and is provided with a graduated position indicator showing 0° to 90°. The actuator may be stalled anywhere in its normal rotation without the need of mechanical end switches. Power consumption is reduced in holding mode. The actuator is double insulated so an electrical ground connection is not necessary. The TF-S versions are provided with one built-in auxiliary switch. This SPDT switch is provided for safety interfacing or signaling, for example, for fan start-up. The switching function is adjustable between 0° and 95°.

**Safety Note:** Screw a conduit fitting into the actuator's bushing. Jacket the actuator's input and output wiring with suitable flexible conduit. Properly terminate the conduit in a suitable junction box.

### Dimensions (Inches[mm])

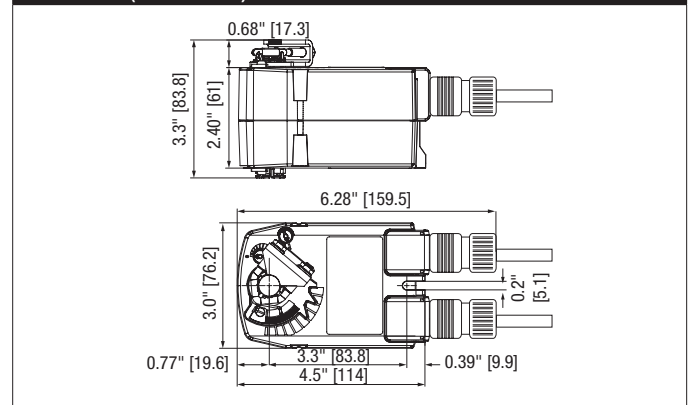

## TFB120-S - Damper Actuator

On/Off, Spring Return, 100 to 240 VAC

Accessories	
AV6-20	6.7" shaft extension for 1/4" to 3/4" diameter shafts.
IND-TF	TF position indicator.
K8 US	Standard TFB(X) clamp (1/4" to 1/2").
KG10A	Ball joint for 3/8" diameter rod, zinc plated.
KG8	Ball joint for 5/16" diameter rod, 90°, galvanized steel.
KH8	Univ. crankarm, slot 21/64" w. for 3/8" to 11/16" dia. shafts.
KH-TF US	TFB(X) crankarm with 5/16" slot.
KH-TF-1 US	TFB(X) crankarm with 1/4" slot.
KH-TF-1.1 US	TFB(X) crankarm for Shafts with 1/4" slot.
SB-TF	TFB(X) mounting kit (T-bracket, bolts).
SH10	Push rod for KG10A ball joint (36" L, 3/8" diameter).
SH8	Push rod for KG6 & KG8 ball joints (36" L, 5/16" diameter).
TF-P	Anti-rotation bracket TF/NKQ/AM/NM/LM.
TOOL-06	8 mm and 10 mm wrench.
ZDB-TF	Angle of rotation limiter for TFB(X).
ZG-113	TFB(X) right angle bracket (4-1/2" H x 5-1/2" W x 2-1/2" D).
ZG-DC1	Damper clip for damper blade, 3.5" width.
ZG-DC2	Damper clip for damper blade, 6" width.
ZG-LMSA-1	Shaft extension for 3/8" diameter shafts (4" L).
ZG-LMSA-1/2-5	Shaft extension for 1/2" diameter shafts (5" L).
ZG-TF112	TFB(X) crankarm adaptor kit (includes ZG-113).
ZG-TF2	TFB(X) crankarm adaptor kit (T bracket included).
ZS-100	Weather shield - galvaneal (13" L x 8" W x 6" D).
ZS-101	Base plate for ZS-100.
ZS-150	Weather shield - PC w/ foam seal (16" L x 8-3/8" W x 4" D).
P475	Shaft mount, non-Mercury aux. switch for 1/2" dia. shafts.
P475-1	Shaft mount, non-Mercury aux. switch for 1" dia. shafts.
PS-100	Actuator power supply and control simulator.
TF-CC US	Cable conduit connector, 1/2".

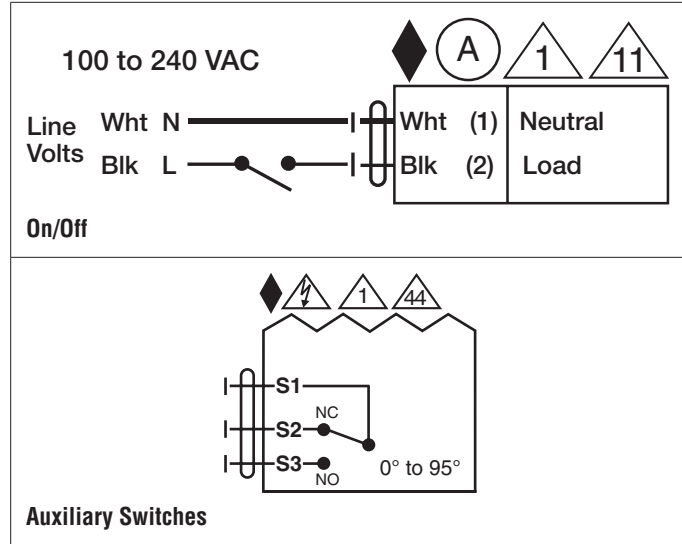

### Typical Specification

On/Off spring return damper actuators shall be direct coupled type which require no crank arm and linkage and be capable of direct mounting to a shaft up to a 1/2" diameter and center a 1/2" shaft. The actuators must be designed so that they may be used for either clockwise or counter clockwise fail-safe operation. Actuators shall be protected from overload at all angles of rotation. If required, one SPDT auxiliary switch shall be provided having the capability of being adjustable. Actuators with auxiliary switch must be constructed to meet the requirements for Double Insulation so an electrical ground is not required to meet agency listings. Actuators shall be cULus listed, have a 5 year warranty, and be manufactured under ISO 9001 International Quality Control Standards. Actuators shall be as manufactured by Belimo.

# TFB120-S - Damper Actuator

On/Off, Spring Return, 100 to 240 VAC

## Wiring Diagrams



### **WARNING! LIVE ELECTRICAL COMPONENTS!**

During installation, testing, servicing and troubleshooting of this product, it may be necessary to work with live electrical components. Have a qualified licensed electrician or other individual who has been properly trained in handling live electrical components perform these tasks. Failure to follow all electrical safety precautions when exposed to live electrical components could result in death or serious injury.



Meets cULus requirements without the need of an electrical ground connection.



Apply only AC line voltage or only UL-Class 2 voltage to the terminals of auxiliary switches. Mixed or combined operation of line voltage/safety extra low voltage is not allowed.



Actuators with appliance cables are numbered.



Provide overload protection and disconnect as required.



Actuators may be connected in parallel if not mechanically linked. Power consumption and input impedance must be observed.



One built-in auxiliary switch (1x SPDT), for end position indication, interlock control, fan startup, etc.

City of Puyallup Development & Permitting Services ISSUED PERMIT	
Building	Planning
Engineering	Public Works
Fire	Traffic

# Model: SP-A700-VG

## Ceiling Exhaust Fan

### Standard Construction Features:

- Galvanized steel housing - Sound absorbing insulation - White coated aluminum grille - Outlet duct collar with integral spring loaded backdraft damper - Dual forward curved wheels - Plug type disconnect - Adjustable mounting brackets - Square duct connection - Dual galvanized steel scroll design - Field rotatable discharge

### Selected Options & Accessories:

Motor rated for continuous use  
Motor - Vari-Green EC motor w/Mounted Potentiometer Dial  
UL/cUL 507 Listed - Electric Fan  
Isolation Kit, (PN: VI KIT-SP/CSP), Shipped Loose  
Adjustable easy installation mounting bracket  
Aluminum Grille with White Enamel Finish  
Polypropylene Wheel Material

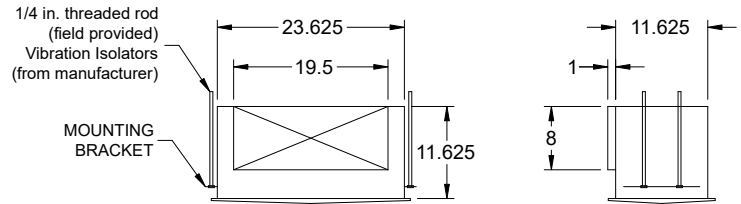
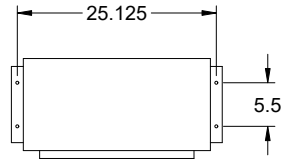

Dimensional	
Quantity	1
Weight w/o Acc's (lb)	39
Weight w/ Acc's (lb)	40

Performance	
Requested Volume (CFM)	700
Actual Volume (CFM)	700
Total External SP (in. wg)	0.3
Fan RPM	1298
* FLA (A)	4.1
Elevation (ft)	289
Airstream Temp.(F)	70
Air Density (lb/ft3)	0.074
Sones	6.5

Motor	
Motor Mounted	Yes
** Input Watts (W)	174
Voltage/Cycle/Phase	115/60/1
Enclosure	TENV
Control Input Voltage	9.6

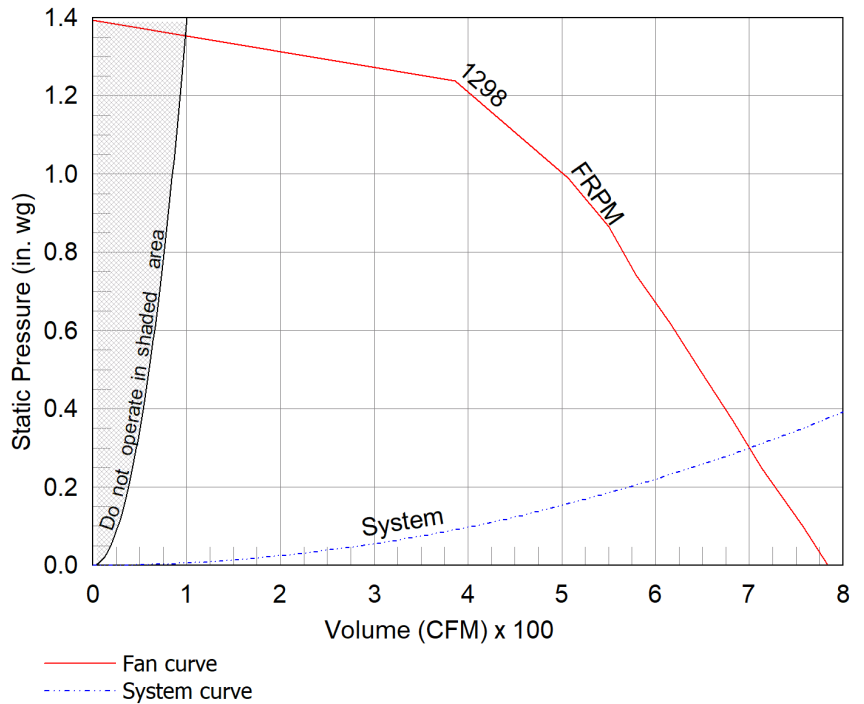

### Notes:

All dimensions shown are in units of in.  
\*FLA is approximate and will vary slightly with the motor.  
Sones - calculated using AMCA 301 at 5 ft  
\*\* Wattage is shown at free air.  
\*\* Wattage is approximate and may vary between motors.



# Vari-Green Motor & Control Options

An EC motor that uses AC input power and internally converts it to DC power. Potentiometer (dial) mounted on the motor enclosure adjusts the speed (RPM) down 80%. Vari-Green motors feature a soft-start and inherent thermal and current protection built into each unit. Inrush current at start up is eliminated and the motor will automatically reduce speed or turn off if overloaded or it becomes too hot.

### Motor Configuration

Input Voltage: 115  
Speed Reference: Dial on Motor  
Permanent Dial: Yes

### Control Configuration

Control Type: Dial on Motor  
Transformer: None

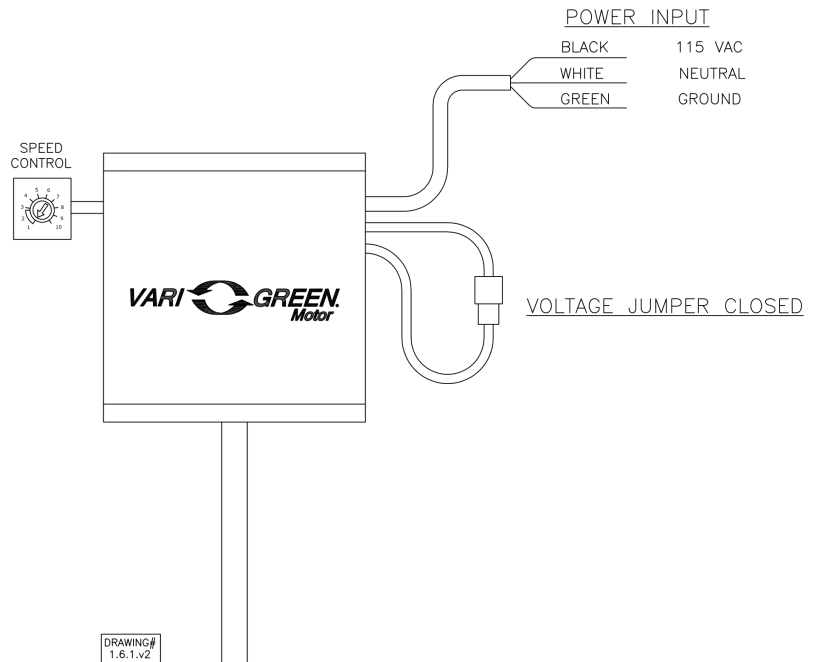

# Isolation Kit

Type: Hanging

City of Puyallup Development & Permitting Services ISSUED PERMIT	
Building	Planning
Engineering	Public Works
Fire	Traffic

### Standard Construction Features:

- Neoprene vibration isolation for hanging installation - Kit includes four isolators and all hardware necessary for mounting one unit except for the 0.25 in. x 20 in. threaded rod to be supplied by others - Fan mounting brackets include prepunched mounting holes for ease of installation

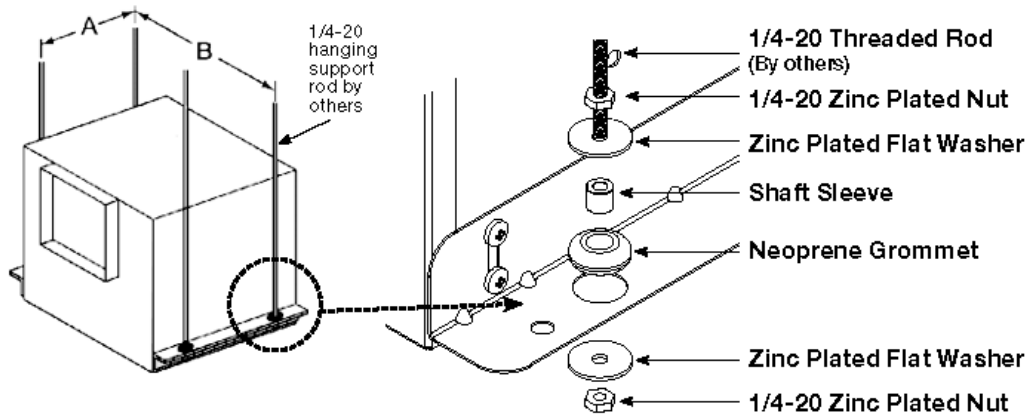

Unit Size	A	B
B50-B200	4 1/2 (114)	15 5/8 (397)
A50-A190	5 1/2 (140)	14 5/8 (371)
A200-A390	6 3/4 (171)	15 1/2 (394)
A410, A510, A710, A780	9 1/4 (235)	19 5/8 (498)
A700	5 1/2 (140)	25 1/8 (638)
A900 - A1050, A1410 - A1550	9 1/4 (235)	25 3/8 (645)
A1750, A2150	9 1/4 (235)	36 3/4 (933)
A3600	9 1/4 (235)	48 5/8 (1235)
All dimensions shown in inches (millimeters).		

Description	Qty
Neoprene Grommets	4
1 x 32 Zinc Plated Nuts	8
Zinc Plated Flat Washers	8
3/8 x 3/16 Shaft Sleeves	4

# Model: CUE-120-VG

Direct Drive Upblast Centrifugal Roof Exhaust Fan

Previously: CUE-121-VG

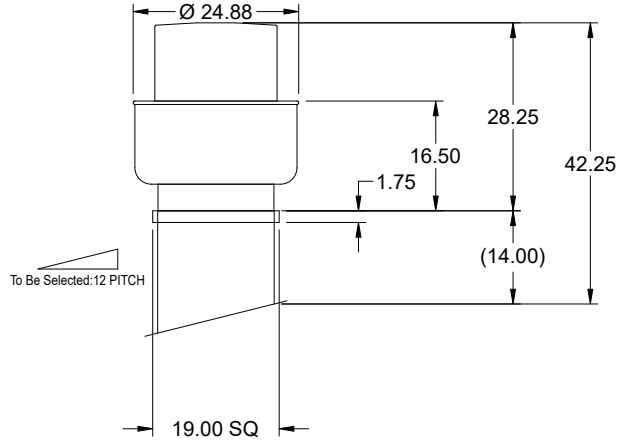

Dimensional	
Quantity	1
Weight w/o Acc's (lb)	51
Weight w/ Acc's (lb)	61
Weight w/ Acc's and Curb (lb)	86
Standard Curb Cap Size (in.)	19 x 19
Optional Damper (in.)	12 x 12
Roof Opening (in.)	15.5 x 15.5

Performance	
Requested Volume (CFM)	1,400
Actual Volume (CFM)	1,400
Total External SP (in. wg)	0.905
Fan RPM	1586
Operating Power (hp)	0.37
Elevation (ft)	289
Airstream Temp.(F)	70
Air Density (lb/ft3)	0.074
Tip Speed (ft/min)	5,426
Static Eff. (%)	54

Misc Fan Data	
Fan Eff. Index (FEI)	-
Outlet Velocity (ft/min)	1,094

Motor	
Motor Mounted	Yes
Size (hp)	1/2
Voltage/Cycle/Phase	115/60/1
Enclosure	ODP
Motor RPM	1725
Efficiency Rating	High
Windings	1
FLA (Amps)	6.4
Min. Circuit Ampacity (MCA)	8
Max. Overcurrent Protection (MOP)	15
Short Circuit Current Rtg (SCCR)	5 kA

OVERALL HEIGHT MAY BE GREATER DEPENDING ON MOTOR, ADAPTER, AND/OR HINGE BASE.

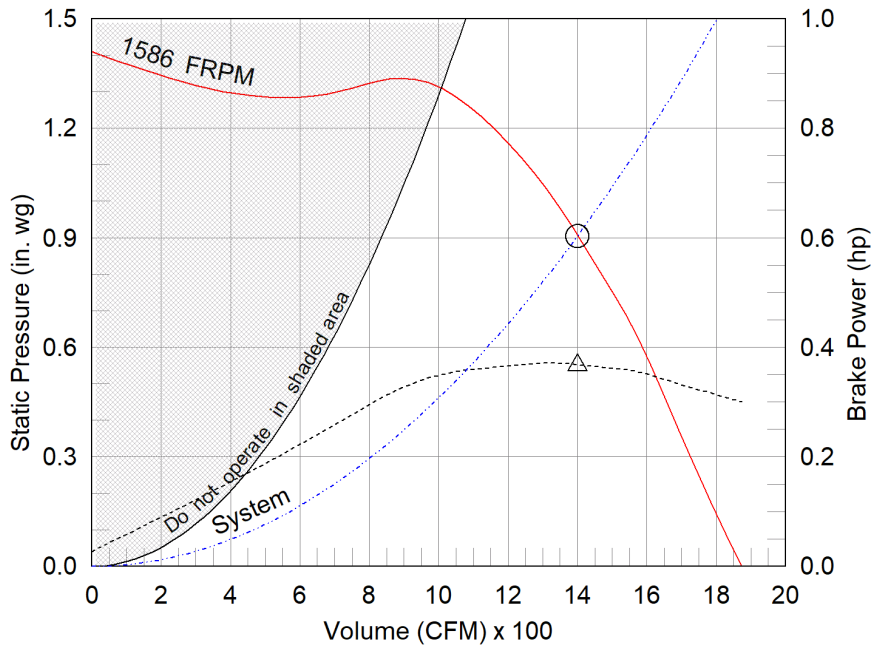

- △ Operating Bhp point
- Operating point at Total External SP
- Fan curve
- - - System curve
- - - Brake horsepower curve

**Static Pressure Calculations**

External SP	0.6 in. wg
Damper	0.305 in. wg
<b>Total External SP</b>	<b>0.905 in. wg</b>

**Notes:**

All dimensions shown are in units of in.  
\*NEC FLA, MCA and MOP are for reference only – based on tables 430.248 or 430.25 of National Electric Code 2020. Actual motor FLA may vary, for sizing thermal overload, consult factory.  
MCA and MOP values shown only account for the motor, not accessories (damper actuator, field supplied VFD, etc).  
LwA - A weighted sound power level, based on ANSI S1.4  
dBA - A weighted sound pressure level, based on 11.5 dB attenuation per Octave band at 5 ft - dBA levels are not licensed by AMCA International  
Sones - calculated using ANSI/AMCA 301 at 5 ft

**Sound Power by Octave Band**

Sound Data	62.5	125	250	500	1000	2000	4000	8000	LwA	dBA	Sones
Inlet	80	79	86	71	67	66	60	52	79	67	15.7



## Model: CUE-120-VG

### Direct Drive Upblast Centrifugal Roof Exhaust Fan

#### Standard Construction Features:

- Aluminum housing - Backward inclined aluminum wheel - Aluminum curb cap with prepunched mounting holes - Drain trough - Ball bearing motors (sizes 85-300 and all Vari Green), sleeve bearing motors (sizes 60-80) - Motor isolated on shock mounts - Corrosion resistant fasteners

#### Selected Options & Accessories:

Motor - Vari-Green EC motor  
Control - Dial for balancing  
Standard Curb Cap Size - 19 Square  
UL/cUL 705 Listed - "Power Ventilators"  
Switch, NEMA-1, T.O., Toggle, Shipped with Unit, \*\*\*Attn: Disconnect enclosure may be too large to fit in motor compartment.  
Foam Curb Seal (Factory Applied)  
Coated with Hi-Pro Polyester, Concrete Gray-RAL 7023, Fan And Attached Acc  
Birdscreen: Stainless Steel, nom. 86% Free Area  
Conduit Chase Qty 1  
Unit Warranty: 1 Yr (Standard)  
Damper Shipped Loose, WD-100-PB-12X12, Gravity Operated, Not Coated, Nominal Size

#### Selected Sub Marks

See individual submittals for full details  
GPIP-19-G14

***The Vari-Green Motor included in this order has a 'Multi-Voltage' ability. The red wire on the motor is called a 'Voltage Doubler', and when it is connected the motor can be powered by 115V.***

***If the Red wire is disconnected, then the motor can be powered with 208-230/277V. The motor will leave the factory with the voltage doubler wired per the order.***

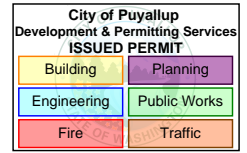

# Disconnect Switch

## Enclosure Rating: NEMA-1

### Standard Construction Features:

Enclosure constructed for indoor use to provide a degree of protection to personnel against incidental contact with the enclosed equipment and to provide a degree of protection against falling dust. This enclosure meets the rod entry and the indoor corrosion protection design tests. The rod entry test is intended to simulate incidental contact with enclosure equipment. Enclosure is equipped with provision to lockout in the off position with customer supplied lock.

### Disconnect Switch Configuration

Type:	Toggle	Motor Size:	1/2 hp	Voltage:	115	UL Listed:	Yes
Manufacturer:	Square D	Cycle:	60	Amperage:	30	CSA Approved:	Yes
Overload Protection:	Thermal Overload	Phase:	1	Switch Pole(s):	1	Rating:	1 hp
Junction Box Mtg.:	Ship With Unit	RPM:	1725	Exp. Resist. Wiring:	None		
Switch Mounting:	Shipped With Unit						

### Electrical Drawing Details

### Wiring Schematic

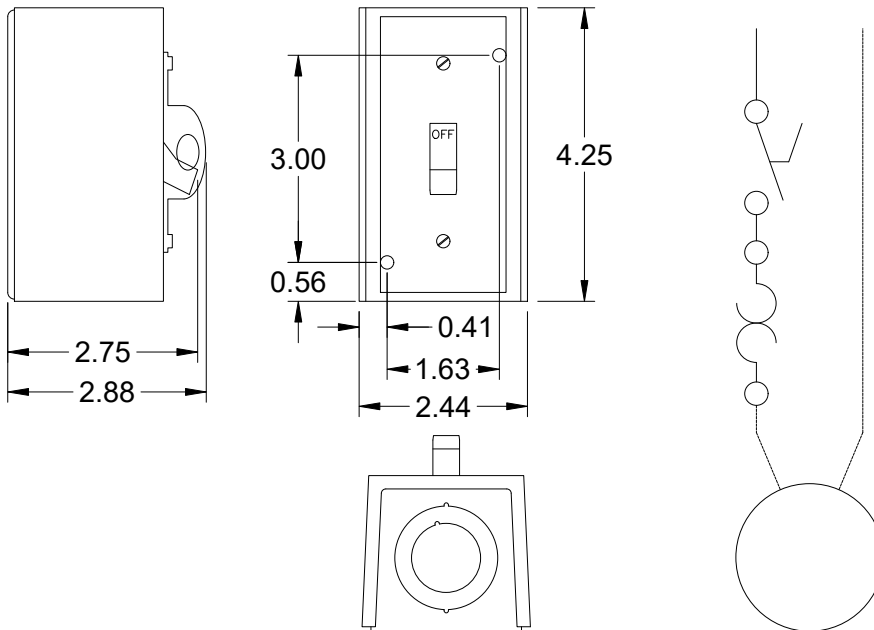

Notes: All dimensions shown are in units of in.

# Assembly Drawing

Type: Direct Drive Upblast Centrifugal Roof Exhaust Fan

City of Puyallup Development & Permitting Services ISSUED PERMIT	
Building	Planning
Engineering	Public Works
Fire	Traffic

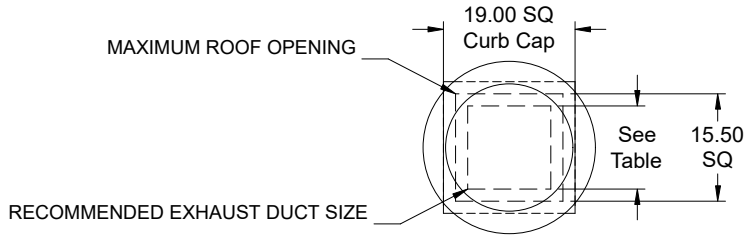

DUCT TYPE	SIZE
STANDARD	12 SQ
FIRE-WRAPPED	8 SQ

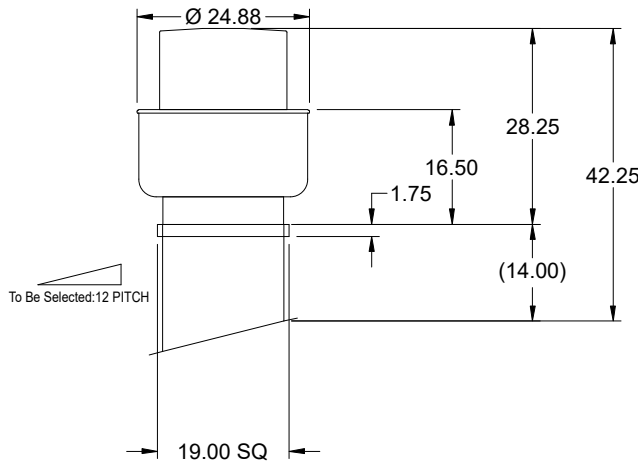

DUCT DIMENSIONS ARE LARGEST POSSIBLE DUCT TO FIT THROUGH CURB.  
CONSULT SYSTEM DESIGN ENGINEER FOR RECOMMENDED DUCT SIZE.

OVERALL HEIGHT MAY BE GREATER DEPENDING ON  
MOTOR, ADAPTER, AND/OR HINGE BASE.

Notes: All dimensions shown are in units of in..

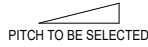
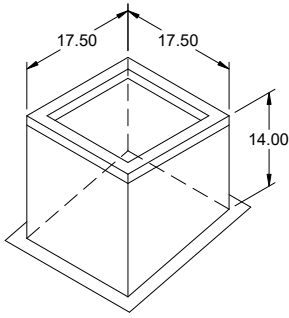

## Model: GPIP

### Pitched Roof Curb

#### Standard Construction Features:

- Roof Curb fits between the building roof and the fan mounted directly to the roof support structure - Constructed of either 18 ga galvanized steel or 0.064 in. aluminum - Designed for pitched roofs - Straight sided without a cant - Wood nailer for attachment of roof flashing material - 2 in. mounting flange - 1 in. thick 3 lb density insulation - Height - Available from 12 in. to 24 in. as specified in 0.5 in. increments. Notes: - The maximum roof opening dimension should not be greater than the "Actual" top outside dimension minus 2 in.. - The minimum roof opening dimension should be at least 2.5 in. more than the damper dimension or recommended duct size. - The Roof Opening Dimension may or may not be the same as the Structural Opening Dimension.

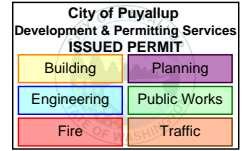

#### General

Tag	Qty	Model	Sizing Method	Undersizing (in.)	Pitch (in.)	Pitch Run	Weight (lb)	Shipped Assembled	Union Label
	1	GPIP-19	Nominal	1.5	???	Long Side	25	Yes	No Preference

#### Dimensions

Curb Height (in.)	Nominal Outside Width (in.)	Nominal Outside Length (in.)	Actual Outside Width (in.)	Actual Outside Length (in.)	Actual Inside Width (in.)	Actual Inside Length (in.)	Hinge Base Width* (in.)	Hinge Base Length* (in.)
14	19	19	17.5	17.5	14	14	18	18

\*May not be applicable

#### Accessories

Material	Security Bars	Liner	Insulation (in.)	Insulation R Value
Galvanized	No	No	1	R4.3

# Model: SP-A250

## Ceiling Exhaust Fan

Tags: EF-2 EF-3

### Standard Construction Features:

- Corrosion resistant galvanized steel scroll and housing - Sound absorbing insulation - White designer non-yellowing grille - Rectangular outlet duct collar with integral spring loaded backdraft damper - Double inlet forward curved wheel - Plug type disconnect - Adjustable mounting brackets - Field rotatable discharge

### Selected Options & Accessories:

Motor rated for continuous use  
Motor with Thermal Overload  
Motor with CSA Approval  
Motor with 40 Degree C Ambient Temperature  
UL/cUL 507 Listed - Electric Fan  
Solid State Speed Control, 6 Amp, Shipped Loose  
Square Hooded Wall Cap, (PN: WC-8X8) Shipped Loose  
Isolation Kit, (PN: VI KIT-SP/CSP), Shipped Loose  
Adjustable easy installation mounting bracket  
Energy Star Certified  
Standard Grille  
Polypropylene Wheel Material  
Can Be Used to Comply with: ASHRAE 62.2, California Title 24, and Washington State Energy Code

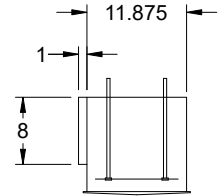
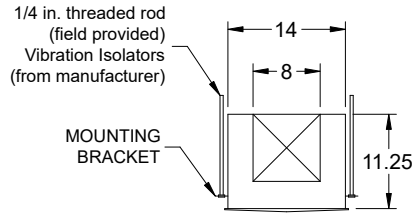
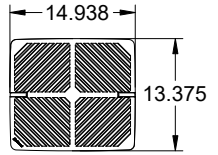
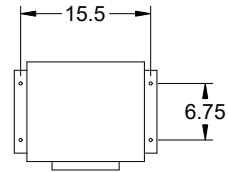

Dimensional	
Quantity	2
Weight w/o Acc's (lb)	24
Weight w/ Acc's (lb)	26

Performance	
Requested Volume (CFM)	250
Actual Volume (CFM)	244
Total External SP (in. wg)	0.285
Fan RPM	1000
* FLA (A)	0.56
Elevation (ft)	289
Airstream Temp.(F)	70
Air Density (lb/ft3)	0.074
Sones	3.0

Motor	
Motor Mounted	Yes
** Input Watts (W)	83
Voltage/Cycle/Phase	115/60/1
Enclosure	ODP

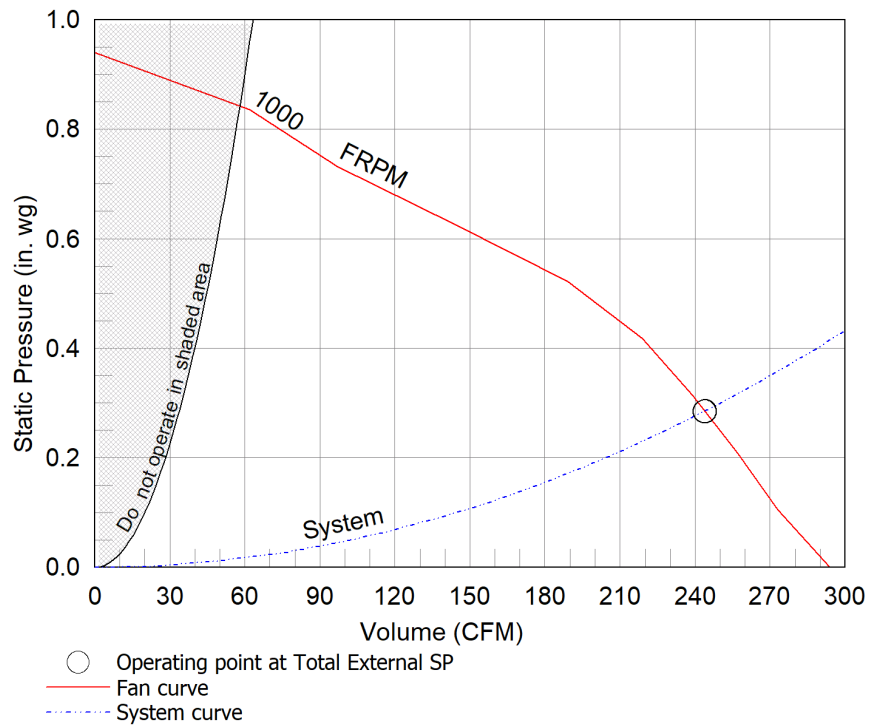

### Notes:

All dimensions shown are in units of in.  
\*FLA is approximate and will vary slightly with the motor.  
Sones - calculated using AMCA 301 at 5 ft  
\*\* Wattage is approximate and may vary between motors.



# Model: SP-A250

## Ceiling Exhaust Fan

### Standard Construction Features:

- Corrosion resistant galvanized steel scroll and housing - Sound absorbing insulation - White designer non-yellowing grille - Rectangular outlet duct collar with integral spring loaded backdraft damper - Double inlet forward curved wheel - Plug type disconnect - Adjustable mounting brackets - Field rotatable discharge

### Selected Options & Accessories:

Motor rated for continuous use  
 Motor with Thermal Overload  
 Motor with CSA Approval  
 Motor with 40 Degree C Ambient Temperature  
 UL/cUL 507 Listed - Electric Fan  
 Solid State Speed Control, 6 Amp, Shipped Loose  
 Square Hooded Wall Cap, (PN: WC-8X8) Shipped Loose  
 Isolation Kit, (PN: VI KIT-SP/CSP), Shipped Loose  
 Adjustable easy installation mounting bracket  
 Energy Star Certified  
 Standard Grille  
 Polypropylene Wheel Material  
 Can Be Used to Comply with: ASHRAE 62.2, California Title 24, and Washington State Energy Code

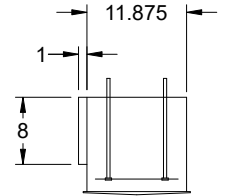
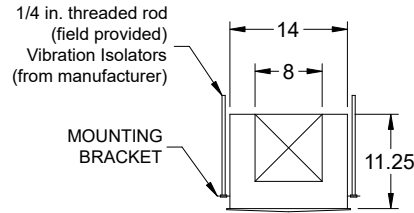
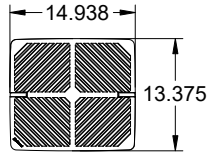
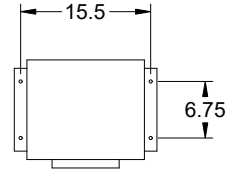

Dimensional	
Quantity	1
Weight w/o Acc's (lb)	24
Weight w/ Acc's (lb)	26

Performance	
Requested Volume (CFM)	250
Actual Volume (CFM)	244
Total External SP (in. wg)	0.285
Fan RPM	1000
* FLA (A)	0.56
Elevation (ft)	289
Airstream Temp.(F)	70
Air Density (lb/ft3)	0.074
Sones	3.0

Motor	
Motor Mounted	Yes
** Input Watts (W)	83
Voltage/Cycle/Phase	115/60/1
Enclosure	ODP

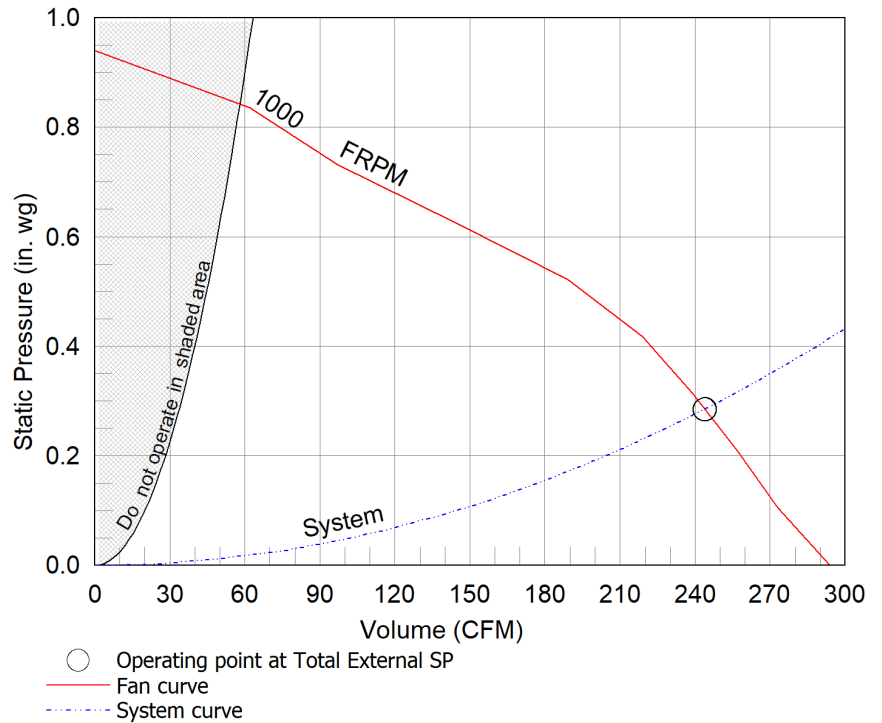

### Notes:

All dimensions shown are in units of in.  
 \*FLA is approximate and will vary slightly with the motor.  
 Sones - calculated using AMCA 301 at 5 ft  
 \*\* Wattage is approximate and may vary between motors.



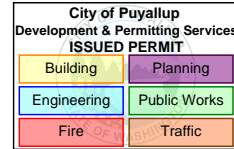

## Heavy Duty Grilles

Model: XG-4500S Steel Heavy Duty Gym Return Grille Horizontal Blades Zero Degree Deflection

### Dimensions

ID#	Tag	Qty	Model	Neck 1	Neck 2	Round Neck (in.)
9-1		2	XG-4500S	12	14	N/A

### Note:

- Quantities and Sizes listed are for submittal purposes only, to be verified prior to order
- Submittal information is deemed correct at time of printing, however in the interest of product improvement Greenheck reserves the right to make changes without notice.

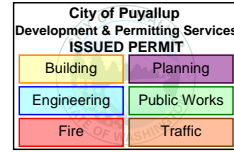

## Heavy Duty Grilles

Model: XG-4500S Steel Heavy Duty Gym Return Grille Horizontal Blades Zero Degree Deflection

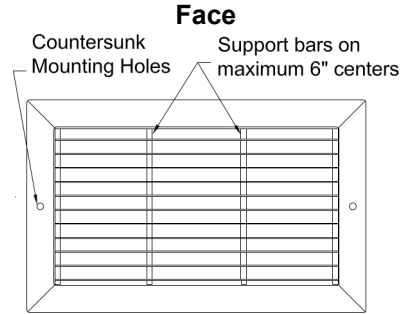
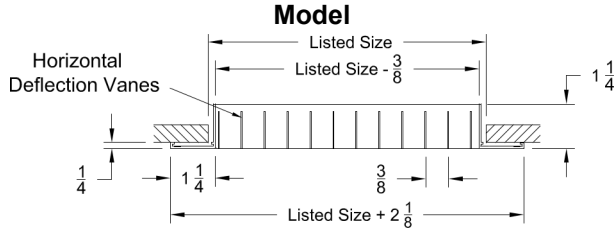

### Construction

ID#	Border Type	Finish Color
9-1	Flush Surface Mount	White

### Accessories

ID#	Damper	Screw Holes	Grid	Plaster Frame	Insect Screen	Transition
9-1	None	Yes	None	None	No	None

### Included

ID#	Tag	Qty	Neck 1	Neck 2	Round Neck
9-1		2	12	14	N/A

City of Puyallup Development & Permitting Services ISSUED PERMIT			
Building	Planning	Engineering	Public Works
Fire	Traffic		

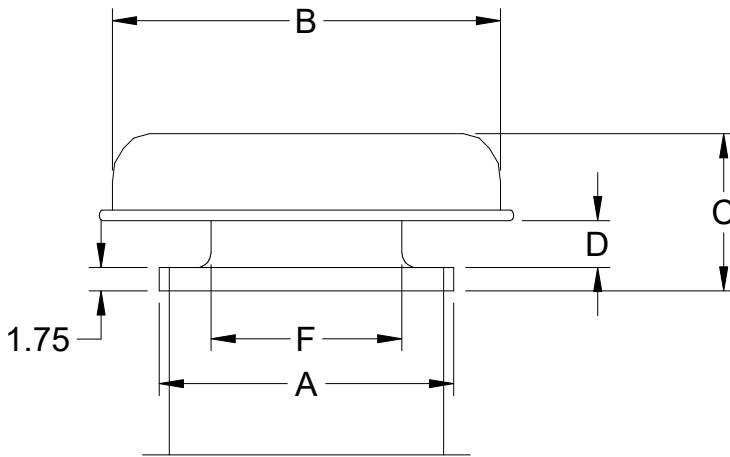

**Model: GRSI**

**Standard Construction Features:**

- Aluminum housing.
- Aluminum curb cap with prepunched mounting holes.
- Recommended roof opening dimension is at least 2.5 in. larger than the damper size.

**Dimensions**

ID#	Tag	Qty	Model	Model Size (in.)	A (in.)	B (in.)	C (in.)	D (in.)	E (in.)	F (in.)	Curb Cap Width (in.)	Curb Cap Length (in.)	Weight (lb)
3-1	GV1	1	GRSI-15	15	22	29	11.75	3.5	N/A	14.25	22	22	28

**Construction**

ID#	Flashing Flange	Installation Type	Insect Screen	Birdscreen Material	Unit Material
3-1	No	Ducted	Yes	Aluminum	Aluminum

**Accessories**

ID#	Hinged Curb Cap	Curb Seal	Hood Insulation (in.)	Tie Down Points
3-1	No	Foam - Applied	None	No

**Roof Curbs**

ID#	Model	Height (in.)	Width (in.)	Length (in.)
3-1	GPIP	14	22	22

**Dampers**

ID#	Model	Width (in.)	Length (in.)	Blade Action	Frame Type	Actuator Type	Actuator Quantity	Actuator Mounting	End Switch	Damper Mounting
3-1	VCD-33	16	16	Opposed	Channel	115 VAC	1	External	No	Ship Separate

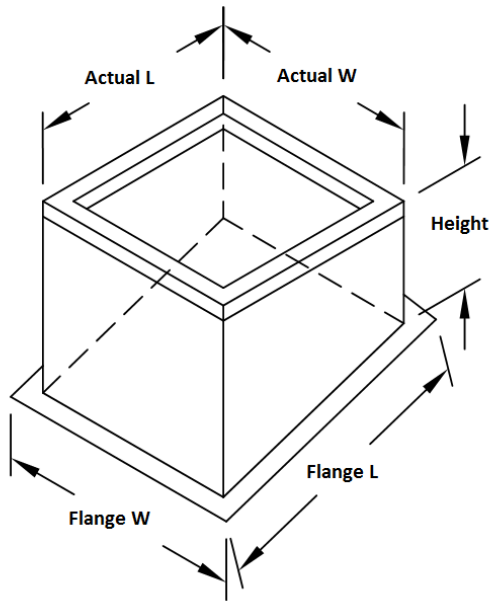

## Model: GPIP

### Pitched Roof Curb

#### Standard Construction Features:

- Roof Curb fits between the building roof and the fan mounted directly to the roof support structure
- Constructed of either 18 ga galvanized steel or 0.064 in. aluminum
- Designed for pitched roofs
- Straight sided without a cant
- Wood nailer for attachment of roof flashing material
- 2 in. mounting flange
- 1 in. thick 3 lb density insulation
- Height - Available from 12 in. to 24 in. as specified in 0.5 in. increments.

Notes:

- The maximum roof opening dimension should not be greater than the "Actual" top outside dimension minus 2 in..
- The minimum roof opening dimension should be at least 2.5 in. more than the damper dimension or recommended duct size.
- The Roof Opening Dimension may or may not be the same as the Structural Opening Dimension.

Please note: Long side and Short side dimensions are positioned differently on the image above.

#### General

ID#	Tag	Qty	Model	Sizing Method	Undersizing (in.)	Pitch (in.)	Pitch Run	Weight (lb)	Shipped Assembled	Union Made
3-1		1	GPIP-22-G14	Nominal	1.5	???	Short Side	30	Yes	No Preference

#### Dimensions

ID#	Curb Height (in.)	Nominal Outside Width (in.)	Nominal Outside Length (in.)	Actual Outside Width (in.)	Actual Outside Length (in.)
3-1	14	22	22	20.5	20.5

#### Accessories

ID#	Material	Security Bars	Liner	Insulation (in.)	Insulation R Value
3-1	Galvanized	No	No	1	R4.3

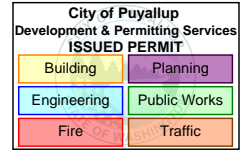

# MSX-P122-H22-D1

## Unit Performance

Design Conditions					
Elevation (ft)	Summer		Winter (°F)	Supply (CFM)	Outdoor Air (CFM)
	DB (°F)	WB (°F)			
289	86.2	66.4	5.0	5,000	5,000

Unit Specifications					
Qty	Weight (lb)	Cooling Type	Heating Type	Unit Installation	Unit ETL Listing
1	1,313 (+/- 5%)	None	Hot Water Coil	Outdoor/Indoor	UL / cUL 60335-2-40

Configuration				
Unit Orientation	Unit Configuration	Outdoor Air Intake	Return Air Intake	Supply Air Discharge
Horizontal	Constant Volume 100% OA	End	-	Bottom

Heating Specifications									
Type	Fluid Type		Flow Rate (GPM)	Fluid PD (ft wg)	Capacity (MBH)	Fluid Conditions		Performance	
	Type	%				EWT (°F)	LWT (°F)	EAT (°F)	LAT (°F)
Hot Water	Propylene	30	31	2.769	300.4	115.0	95.0	5.0	60.5

Air Performance									
Type	Total Volume (CFM)	External SP (in. wg)	Total SP (in. wg)	RPM	Operating Power (hp)	Fan			
						Qty	Type	Size (in.)	Drive-Type
Supply	5,000	3.6	4.185	1625	5.1	1	Plenum	22	Direct-Drive

Motor Specifications					
Motor	Qty	Size (HP)	Enclosure	Efficiency	RPM
Supply Fan Motor	1	7-1/2	ODP	NEMA Premium	1800

Electrical Specifications				
Power Supply	Rating (V/C/P)	MCA (A)	MOP (A)	SCCR
Unit	460/60/3	14	20	5kA



## CONSTRUCTION FEATURES AND ACCESSORIES

Unit	
Unit Installation - Indoor or Outdoor	Std
Unit Construction - Double Wall	X
Wall Insulation - 1in. fiberglass - Entire unit	X
Base Insulation - 1in. fiberglass - entire unit base pan	Std
Paneled Bottom - Sheet metal liner for base insulation	X
Corrosion Resistant Fasteners	Std
Access and Connections - Right side when facing intake	X
Service Access - Hinged access doors	X
Unit Finish - G90 Galvanized	X
Finish Color	
Supply Fan - Direct-drive, backward-curved plenum	X
Supply Fan and Motor Vibration isolation - Neoprene	X
Controls	
Unit Controls - Microprocessor	X
Remote Panel	
BMS Communication - Monitoring and control	
BMS Protocol	
Temperature Control - Discharge control	X
Supply Fan VFD - VFD by factory	X
Supply Fan Control - Constant Volume	X
Unoccupied Mode (Night Setback)	
Recirculation Control	
Control Accessories	
Remote display	
Heating Inlet Air Sensor	X
Cooling Inlet Air Sensor	
Dirty Filter Switch	X
Fire Stat Type III (Ships loose)	
120V/24V Smoke Detector (Ships loose)	
Inlet Damper End Switch	
External Cooling Lockout Relay	
Freeze Protection (Supply Air Low Limit)	X
Auxiliary Supply Starter Contacts	
Auxiliary Exhaust Starter Contacts	
Heating Coil Freeze Protection	
Airflow Proving Monitoring Contact	X

Accessories	
Factory Installed, Lockable, NEMA 3R Disconnect	Std
Weatherhood - Birdscreen	X
Supply Air Filters - 2" aluminum, 20x20x2 - (6)	X
Outdoor Air Inlet Damper - Low leakage	X
Supply Air Outlet Damper	
Return Air Damper	
Diffuser	
Roof Curb	
Combination Curb	
Electrofin Coil Coating	
Fan Bearing Extended Lube Lines	
Inlet Damper Module	X
Spare Belts	
Spare Filters	
Motor with Shaft Grounding	
Service Outlet	
Service Lights	
Warranty Options	
Unit Warranty - 18 months (std.)	X
5 Year Compressor Warranty	

Standard Option	Std
Not Included	
Included	X

### Notes

Birdscreen weatherhoods ship knocked down and require field installation.  
Damper(s) supplied are low leakage, motorized VCD-23 (leakage rate of 3 CFM/ft<sup>2</sup> @ 1 in.wg), Class 1A

### Fan Charts And Performance

Supply Fan Performance									
Total Volume (CFM)	External SP (in. wg)	Total SP (in. wg)	RPM	Operating Power (hp)	Motor		Fan		
					Qty	Size (HP)	Qty	Type	Drive-Type
5,000	3.6	4.185	1625	5.1	1	7-1/2	1	Plenum	Direct

Pressure Drop (in. wg)							
Diffuser	Weatherhood	Filter	Damper	Cooling	Heating	External	Total
-	0.017	0.069	0.06	-	0.439	3.6	4.185

Sound Performance in Accordance with AMCA										
Sound Power by Octave Band								Lwa	dBA	Sones
62.5	125	250	500	1000	2000	4000	8000			
87	84	88	85	84	80	76	71	89	78	31

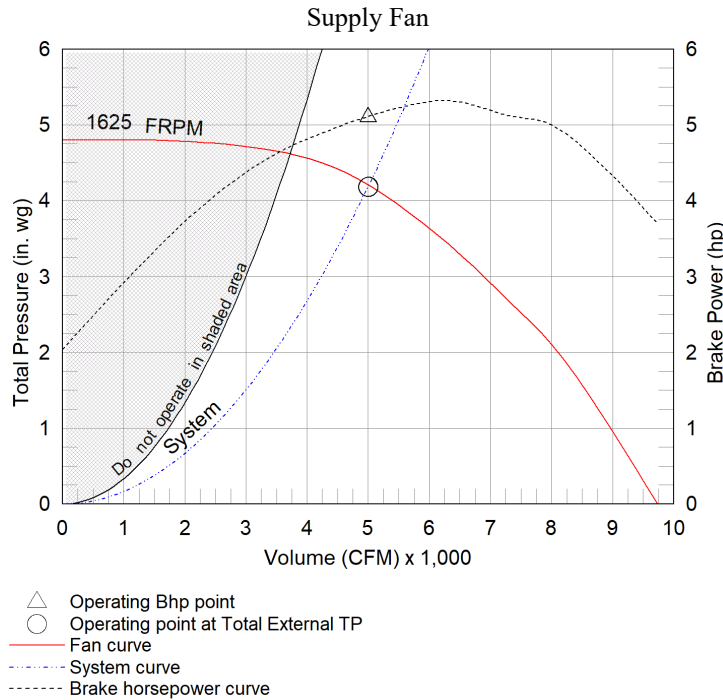

### Heating Specifications

Heating Performance									
Type	Fluid Type		Flow Rate (GPM)	Fluid PD (ft wg)	Capacity (MBH)	Fluid Conditions		Performance	
	Type	%				EWT (°F)	LWT (°F)	EAT (°F)	LAT (°F)
Hot Water	Propylene	30	31	2.769	300.4	115.0	95.0	5.0	60.5

Coil Information				
HW Coil Model	Fins Per Inch	Rows Deep	Face Velocity (ft/min)	Connection Size (in.)
Custom	10	3	625	2.5

Unit Details	
Copper tube, aluminum fin coil construction	Coil control valves must be field provided by others

Heat Coil Connections

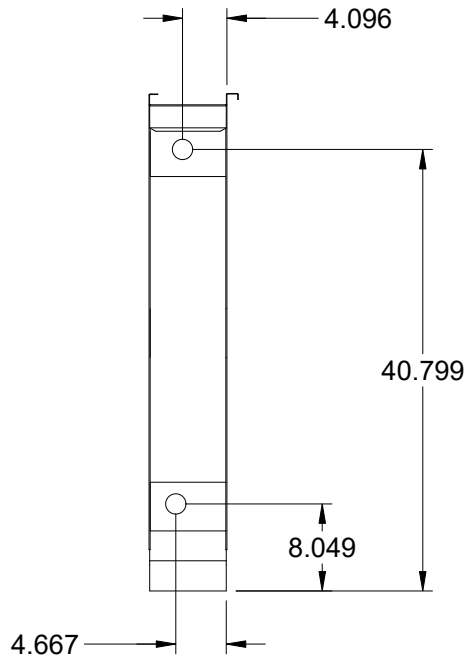

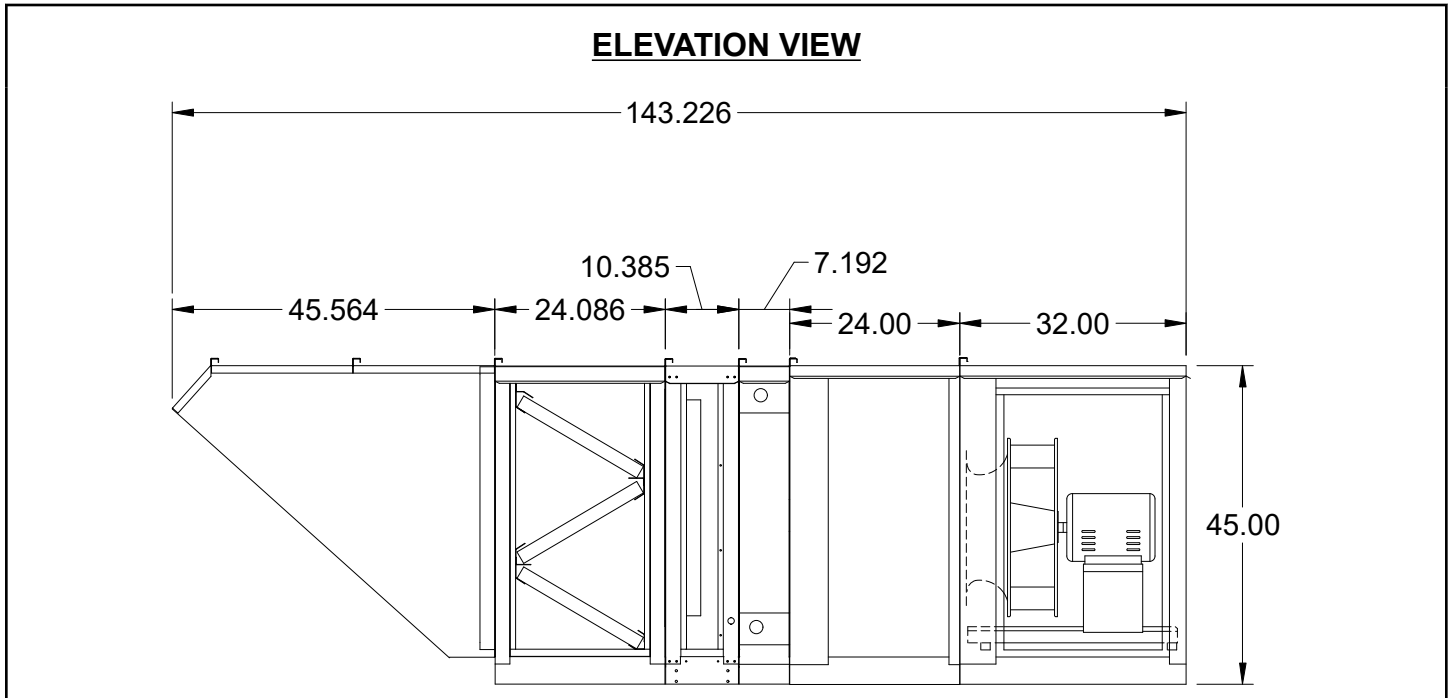

**Notes - Elevation View**

Standard configuration for unit access is on the right-hand side, when looking into the unit intake in the direction of airflow.

Order of unit sections is from intake of unit to discharge of unit.

Sections included on this unit: Weatherhood Section, Filter Section, Damper Section, Heating Section, Control Center Module Section, Blower Section

Insulation: Double Wall, Entire Unit Insulated.

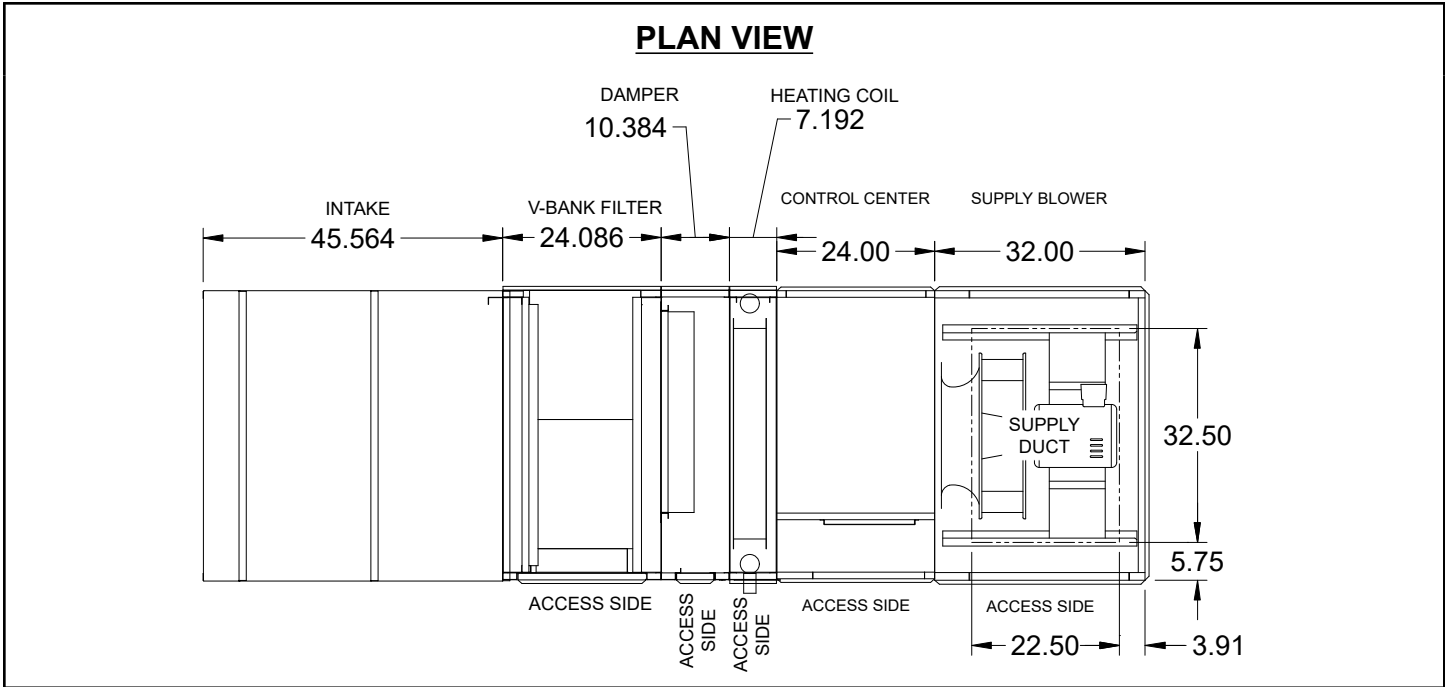

**Notes - Plan View**  
Standard configuration for unit access is on the right-hand side, when looking into the unit intake in the direction of airflow.

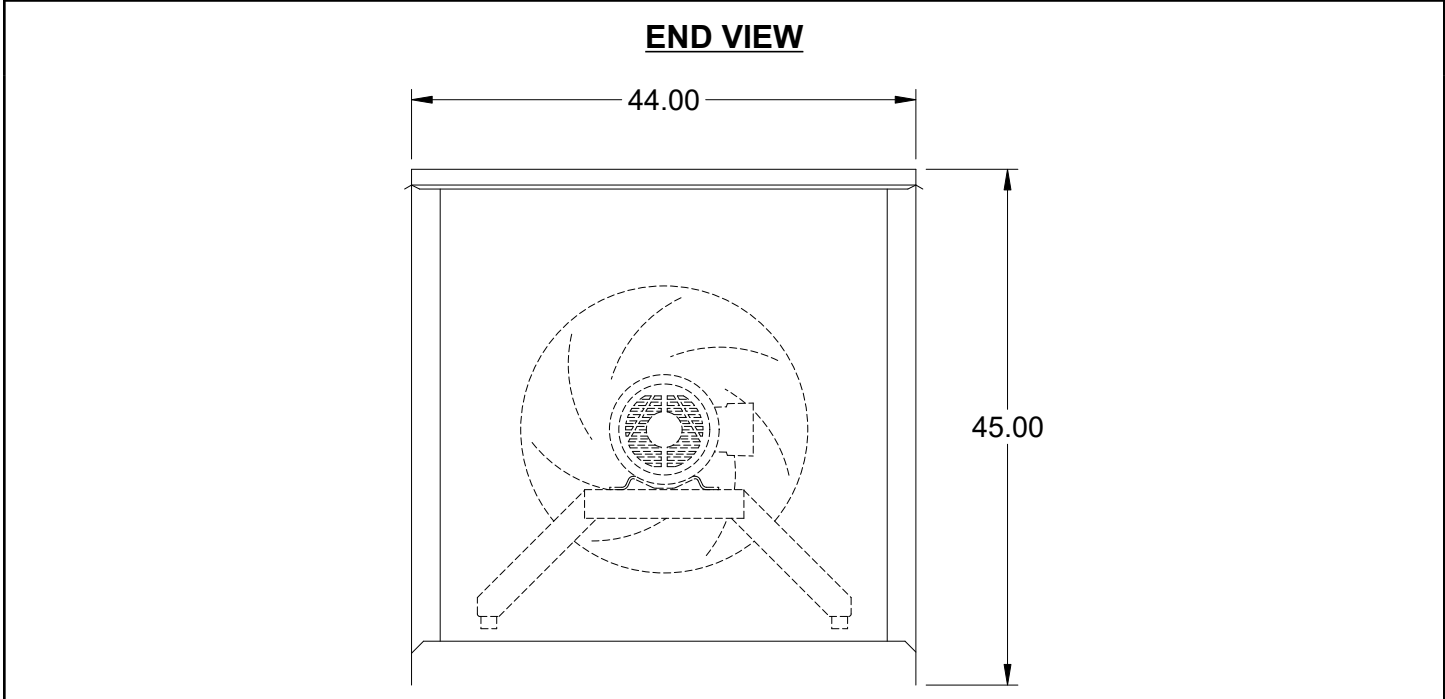

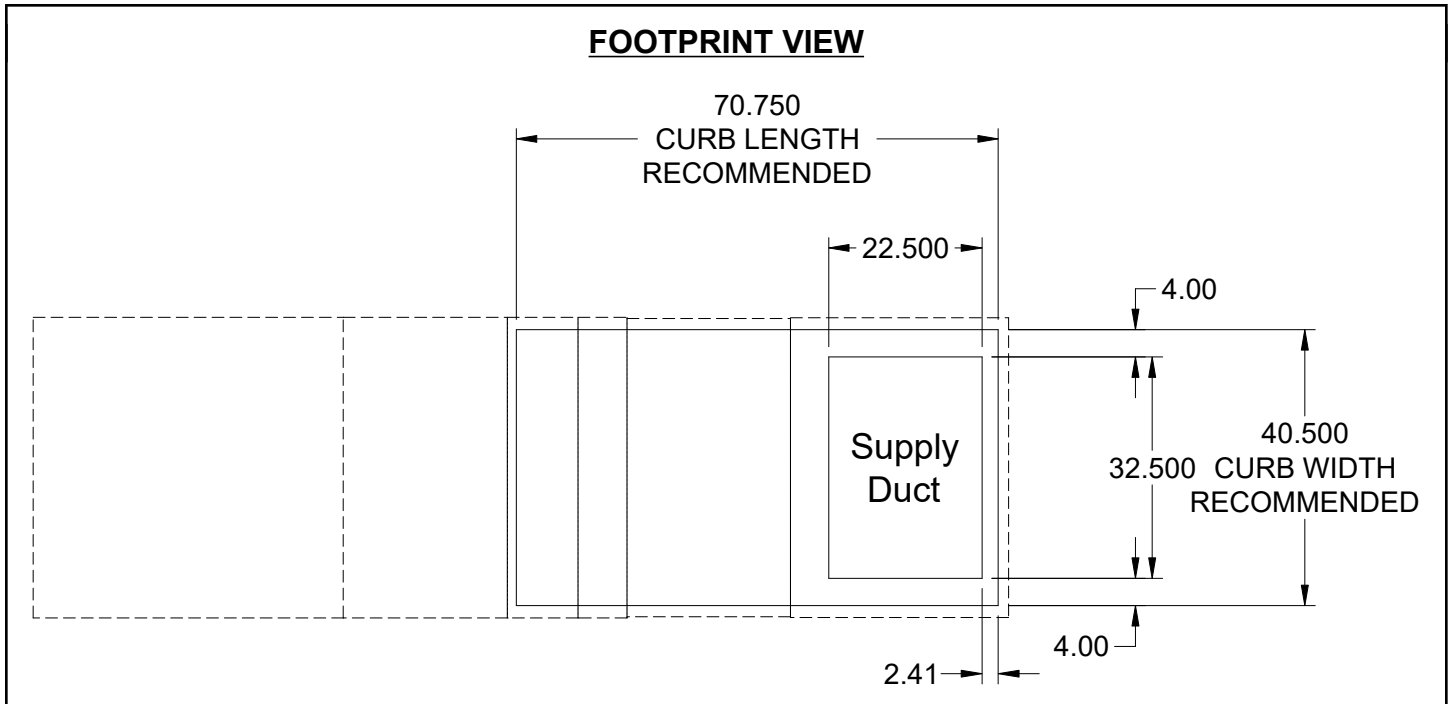

**Notes - Footprint View**

**Minimum Roof Opening:** The minimum roof opening size is the illustrated duct diameter plus 0.25 in. on all sides. For example: If the duct size is 14 x 14 in. square, the minimum roof opening size is 14.5 x 14.5 in. square.

**Maximum Roof Opening:** There must be a minimum perimeter of 1.75 in. between the roof opening and the roof curb. For example: If the roof curb is 75 x 30 in. square, the maximum roof opening is 71.5 x 26.5 in. inches square.

The weatherhood and filter sections of the make-up air unit extend beyond the curb. This is by design, to prevent water infiltration.

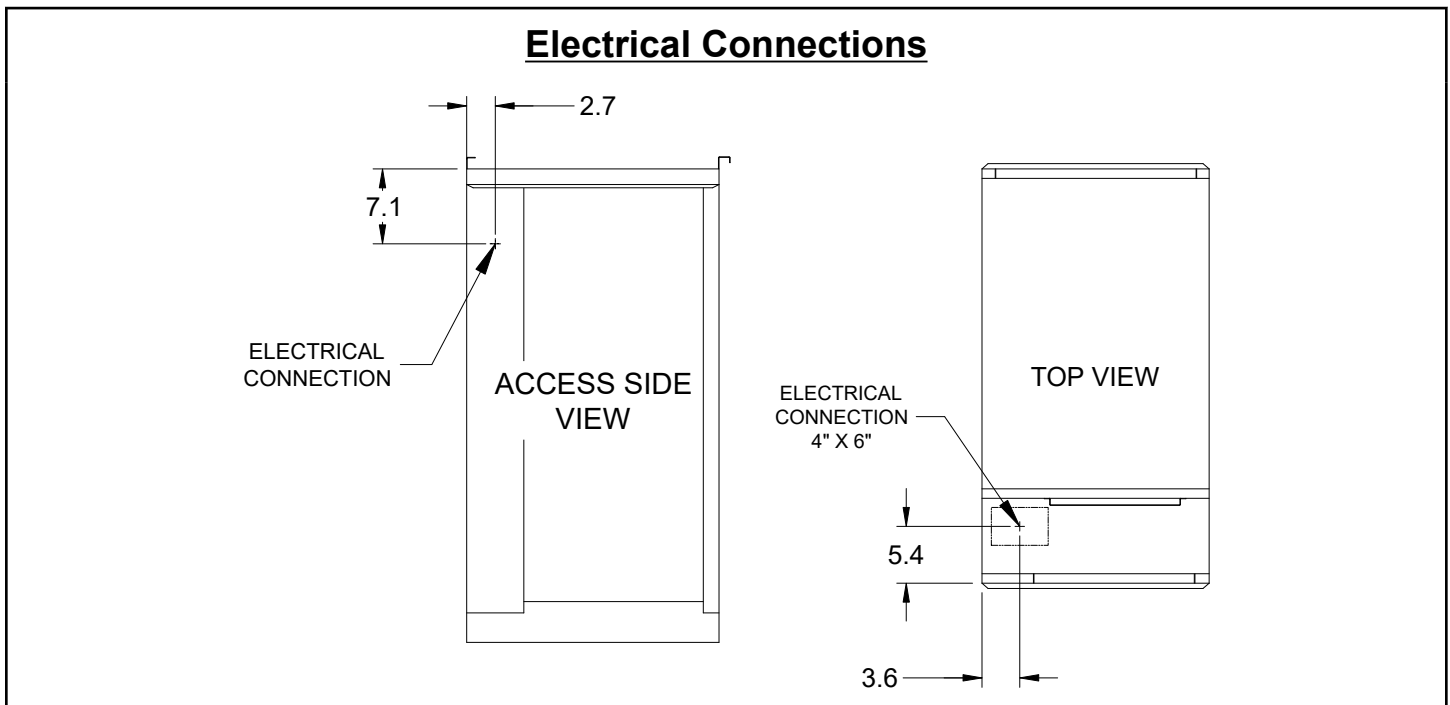

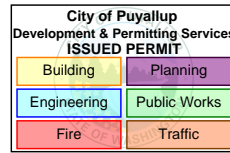

### Clearance Specifications

Recommended Minimum Combustible Clearances				
	Floor (in.)	Top (in.)	Sides (in.)	Ends (in.)
Insulated Units	0	0	0	0
Non-Insulated Units	0	6	6	6

**Notes - Combustible Clearances**  
 Clearance to combustibles is defined as the minimum distance required between the heating source and the adjacent combustible surfaces to ensure the adjacent surface's temperature does not exceed 90 F above the ambient temperature.

Recommended Minimum Service Clearances	
Housing 32 and less (in.)	Housing 35 and higher (in.)
42 on the controls side of the unit	48 on the controls side of the unit

**Notes - Service Clearances**  
 To ensure ample space for component removal (evaporative cooling media, coils, filters, etc.), service clearances should be 6 in. wider than the width of the module itself.

**Wiring Diagram**

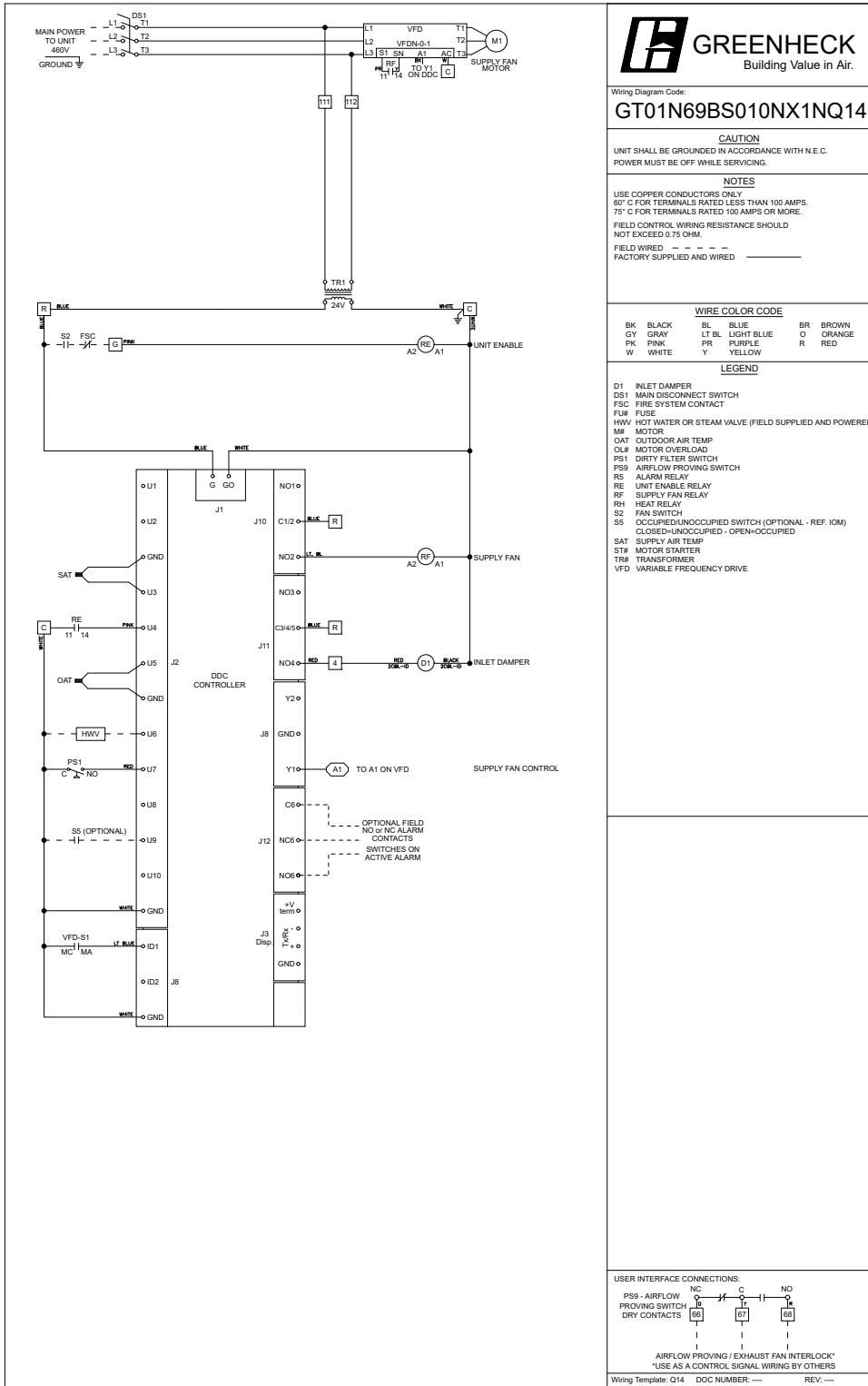
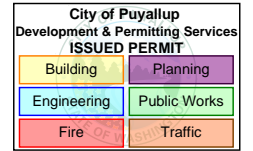

Manufacturer reserves the right to change, modify, or improve this product at anytime

### Corner Weights

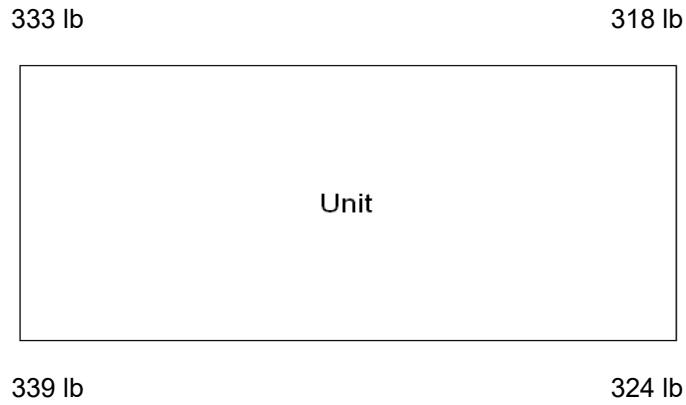

City of Puyallup Development & Permitting Services ISSUED PERMIT	
Building	Planning
Engineering	Public Works
Fire	Traffic

## SEQUENCE OF OPERATIONS

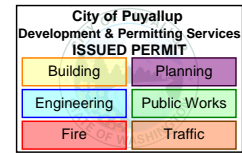

### Unit Controls

The unit shall be provided from the factory with:

- 24VAC Transformer
- Terminal Strip
- Supply Fan VFD
- Factory mounted and wired outdoor air inlet damper with actuator

### Microprocessor Controller

The microprocessor control shall be factory programmed, mounted, wired and tested. Controller shall have a lighted LCD display and keypad for changing set points and monitoring unit operation. The controller shall be equipped with the following sensors:

- Outdoor air temperature sensor
- Supply discharge temperature sensor

### Unit Start Command

A contact closure or jumper wire must be field wired between terminals R and G to enable the unit. When terminal G is energized the unit shall operate as described below. When terminal G is de-energized the unit is disabled.

### Internal Time Clock (Schedule)

The microprocessor controller is equipped with an internal 7-day programmable time clock, allowing the user to add up to seven different occupancy schedules.

### Occupied/Unoccupied Modes

The microprocessor controller offers the following modes for determining occupancy:

- The internal time clock
- A remote contact (see wiring diagram for details)

The unit can be temporarily overridden to the occupied mode via a dry contact or the keypad display. After the override time has expired (1 hr, adj) the unit will return to the scheduled occupied/unoccupied mode.

### Occupied Mode Unit Start-Up Sequence

- Unit enable input must be closed (contact closure between R and G).
- Initial delay, microprocessor controller initialization sequence.
- Factory mounted and wired outdoor air inlet damper actuator is powered open.
- Supply fan starts after adj. delay.
- Tempering operation begins (see modes below).

### Supply Fan Sequence (Occupied)

The unit has been provided with a factory mounted variable frequency drive (VFD). The variable frequency drive shall control the supply fan speed as indicated by the following sequence:

#### Constant Volume:

The VFD shall be programmed from the factory for a constant supply fan speed. This is to be adjusted for air balancing only and is not to be modulated.

### Heating Control

The heating will be locked out when the outside air is above the heating lockout set point (65 F adj.). When enabled heating will be controlled as follows:

#### Hot Water Heating

The controller will output a 0-10 VDC signal to control a field supplied water valve to maintain the active supply temperature set point.

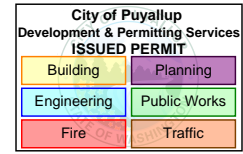

**Supply Temperature Set Point Control (Occupied)**

The active supply temperature set point shall be adjusted (field selectable):

- Locally at the controller.

**Unoccupied Mode (Disabled)**

- Supply Fan Is OFF
- Factory mounted and wired outdoor air inlet damper actuator is de-energized and spring returns to the closed position.

**Supply Air Low Limit**

If the supply air temperature drops below 35 F (adj.) for 300 seconds (adj.), the controller will de-energize the unit and generate an alarm.

**Alarm Management**

The microprocessor controller will monitor the unit status for alarm conditions. Upon detecting an alarm, the controller will record the alarm description, time, date, available temperatures, and unit status for user review. A digital output is reserved for remote alarm indication.

**Possible Alarms Include:**

- **Global Alarm**  
Indication that one or more alarms are present.
- **Outdoor Air Inlet Temperature Sensor Alarm**  
Outdoor Air Inlet Temperature Sensor Alarm: Failure of the outdoor air inlet temperature sensor.
- **Supply Air Discharge Temperature Sensor Alarm**  
Failure of the supply air discharge temperature sensor. Unit is shut down.
- **Supply Air Low Limit Alarm**  
Supply air has fallen below 35 F (adj.) for 300 seconds (adj.). Unit is shut down.
- **Dirty Filter Alarm**  
Indicates the pressure across the filters has increased above the dirty filter pressure switch setting (field adjustable)
- **Supply Fan Alarm**  
Indicates the supply fan failed to prove for a 30 second (adj.) period.

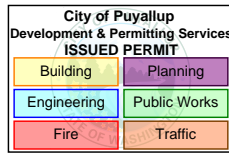

## Warranty Statement for Make-Up Air

### Unit Warranty

Greenheck warrants the equipment to be free from defects in material and workmanship for a period of 18 months from the date of shipment. Initial startup must be completed within six months of the shipment date, and a startup report must be submitted to Greenheck.

### Warranty Notes

Any component which proves defective during the warranty period will be repaired or replaced at Greenheck’s sole option when returned to our factory, transportation prepaid. All warranties do not include labor costs associated with troubleshooting, removal, or installation. Greenheck will not be liable for any consequential, punitive, or incidental damages resulting from use, repair, or operation of any Greenheck product. These warranties are exclusive and are in lieu of all other warranties, whether written, oral, or implied, including the warranty of merchantability and the warranty of fitness for a particular purpose. No person (including any agent or salesperson) has authority to expand Seller’s obligation beyond the terms of this warranty, or to state that the performance of the product is other than that published by Seller.

*As a result of our commitment to continuous improvement, Greenheck reserves the right to change specifications without notice.*



470 Beauty Spot Rd. E, Bennettsville, SC 29512

**DIMENSIONS**

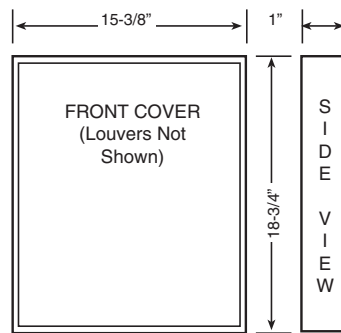
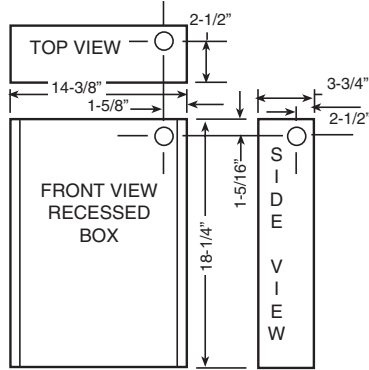

Tags: CH1A, B, CH2

**SELECTION CHART**

CATALOG NO.	VOLTS	WATTS*	BTU/HR	PHASE	AMPS
EFF1500	120	1500	5120	1	12.5
EFF3007	277	3000/1500	10,239	1	10.8
EFF4008	208	4000/2000	13,652	1	19.2
EFF4004	240	4000/2000	13,652/10,239	1	16.7/14.4
	208	3000/1500	10,239/5,120		14.4/7.2
EFF4007	277	4000/2000	13,652/6,826	1	14.4/12.5
	240	3000/1500	10,239/5,120		12.5/6.2
EFF4804	240/208	4800/3600	16,382/12,287	1	20.0/17.3
EFF4807	277/240	4800/3600	16,382/12,287	1	17.3/15.0
EFF3003	347	3000	10,239	1	8.6
EFF3006	600	3000	10,239	1	5.0
EFF4003	347	4000	13,652	1	11.5
EFF4006	600	4000	13,652	1	6.7
EFF4803	347	4800	16,382	1	13.8
EFF4806	600	4800	16,382	1	8
EFF48483	480	4800	16,382	3	5.8
EFF48483LV**	480	4800	16,382	3	5.8

\* Factory wired at higher wattage.  
\*\* Includes 24V Control Relay.

**ACCESSORIES & CONTROLS**

CATALOG NO.	DESCRIPTION
EFFSM	Surface Mounting Frame
EFFR2 (24V)	Low Voltage Time Delay Relay, 45 - 60 seconds to close when energized. Uses remote 24V or 120V power source
EFFR12 (120V)	
EFFTBF	T-bar Frame Kit
EFFT1	Single-pole Thermostat (field Installed)
EFFT2	Double-pole Thermostat (field Installed)
EFFTR4	208/240V Primary Transformer/24V Secondary Control Relay
EFFTR7	277V Primary Transformer/24V Secondary Control Relay

City of Puyallup  
Development & Permitting Services  
**ISSUED PERMIT**

Building	Planning
Engineering	Public Works
Fire	Traffic

**ARCHITECT'S & ENGINEER'S SPECIFICATIONS \*\***

The heating equipment shall include a ceiling mounted EFF electric automatic fan-forced heater suitable for large area heating as manufactured by QMark, A Marley Engineered Products Brand, Bennettsville, SC. The heater shall be designed for ceiling installation, recess or T-Bar mounting. Heaters shall be UL Listed.

**HEATER ASSEMBLY:** The heater assembly, which fits in the back box, shall consist of a fan panel upon which is mounted all of the operational parts of the heater.

**HEATING ELEMENT:** The heating element shall be of the non-glowing design consisting of 80/20 NiCh resistance wire enclosed in a steel sheath to which plate fins are copper brazed. It shall be warranted for 5 years.

**FAN AND FAN MOTOR:** The fan shall be five-bladed aluminum. The fan motor shall be totally enclosed.

**FAN DELAY SWITCH:** Fan control shall be of bi-metallic, snap-action type and shall activate fan after heating element reaches operating temperature. The fan shall continue to operate after the thermostat is satisfied and until the heating element is cool.

**THERMAL CUTOFF:** A thermal cutoff shall be built into the system to shut off the heater in the event of overheating.

**DISCONNECT SWITCH:** A double-pole single throw disconnect switch shall be mounted on the back box for positive

disconnect of power supply. It will be completely concealed behind the faceplate.

**BACK BOX:** The back box shall be designed for duty as a recessed rough-in box either masonry or frame installations, and is also used with the surface mounting frame in surface mounting installations. The back box shall be 20-gauge galvanized steel and shall contain knockouts through which power leads are brought.

**FACEPLATE:** The louvered faceplate shall be of 14 gauge cold-rolled steel, phosphatized, then electrostatically painted Navajo White by a powder coat process. A 1/4-inch mesh screen shall be installed beneath the faceplate to deter the insertion of foreign objects. The face plate shall be secured to the heating unit with tamper-resistant screws.

**THREE-PIECE DESIGN:** The heater shall be made up of a back box, a heater assembly and a faceplate.

**OPTIONS:**

**THERMOSTAT:** The optional tamper-resistant thermostat shall be of the bi-metallic, snap-action type with enclosed contacts. It shall be completely concealed behind the faceplate to become tamper-resistant (EFFT1 or EFFT2).

**LOW VOLTAGE TIME DELAY RELAYS:** 24 volt and 120 volt low voltage time delay relays are available as optional

equipment to control 208, 240 or 277 volt heaters (with an external supplied 24 or 120 volt control circuit) in conjunction with central energy control systems. The built-in thermostat can then be used as one of the thermostats in an automatic night set back operation. (EFFR2 or EFFR12)

**LOW VOLTAGE**

**TRANSFORMER/RELAYS:** (Primary or Secondary) Transformer/Relays shall be available as optional equipment to control 208, 240 or 277 volt heaters (with single point supply connection and internal supplied 24 volt control circuit) in conjunction with central energy control systems. The built-in thermostat can then be used as one of the thermostats in an automatic night set back operation. (EFFTR4 OR EFFTR7)

**SURFACE MOUNTING FRAME:** The surface mounting frame, designed to allow full surface mounting, shall be of 14 gauge cold-rolled steel, phosphatized, then electrostatically painted by a powder coat process.(EFFSM)

**T-BAR FRAME:** For T-Bar mounting, a 14 gauge cold-rolled steel frame, phosphatized and electrostatically painted by a powder coat process, shall be available. Frame shall be designed to mount in a standard 2' x 2' ceiling grid.(EFFTBF)

\*\* QMark reserves the right to change specifications without prior notice.



470 Beauty Spot Rd. E, Bennettsville, SC 29512  
visit www.qmarkmep.com for more info

City of Puyallup Development & Permitting Services ISSUED PERMIT			
Building	Planning		
Engineering	Public Works		
Fire	Traffic		

Tag: UH-1

**ARCHITECT'S AND ENGINEER'S SPECIFICATIONS\***

- Unit mounts either horizontally or vertically. Totally versatile. For factories, warehouses, garages, stores, shipping rooms, power stations. Can be used for primary, supplementary, spot, or dual-system heating.
- Wide range of optional control kits are field installable, increasing the MUH adaptability to the specification market.
- Forced air unit heater with 10 power ratings; from 3KW to 50 KW heating output; 208, 240, 277 and 480V, 10,230 to 170,500 BTU/hr.
- 32 compatible models (no need to try to assemble a heating system from 70 or 80 models!)
- Heavy gauge die-formed steel housing. Two-toned, smartly styled with stainless steel louvers.
- Advanced pull-through air flow design draws air across heating element for more even air distribution and cooler element operation.
- Specially designed venturi outlet to meet that added throw as required in vertical position.
- Branch circuit fusing (when required).
- Completely enclosed fan motor.
- 1- or 3-phase wiring on 5 through 10 KW 208/240V and 15 KW 208V units (field interchangeable).
- Aluminum-finned, copper clad steel sheath heating element has longer useful life, because of cooler sheath temperature and faster heat dissipation.
- 24V control transformer standard on most models, providing a safer and more accurate means of temperature control. 3KW and 5KW, 208-277V, have line voltage controls as standard (24V control available on made-to-order basis).
- Automatic reset linear thermal cut-out, capillary type, provides protection over entire length of element areas (Manual reset protection available on made-to-order basis).

- 2-speed fan selector switch (25 to 50 KW models).
- Fan delay feature eliminates cold drafts. Element heats up before fan cuts in, then fan continues to distribute heat after element shuts off.
- Ruggedly built, yet lighter weight for easier installation. No piping flutes, valves, or traps.
- Individually adjustable discharge louvers to control air flow.
- Choice of optional diffusers for variety of air patterns, maximizing heat concentration and coverage in the vertical position.
- Meets all UL, NEC, and OSHA requirements.

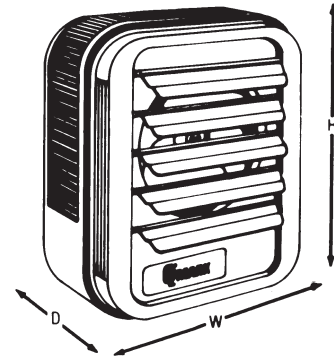

**DIMENSIONS**

CAT. NO.	HEIGHT	WIDTH	DEPTH
MUH-03 & 05	16"	14"	7 <sup>1/2</sup> "
MUH-07 & 10	21 <sup>3/4</sup> "	19"	7 <sup>1/2</sup> "
MUH-15 & 20	21 <sup>3/4</sup> "	19"	12 <sup>3/4</sup> "
MUH-25 & 30	30"	26 <sup>5/8</sup> "	11 <sup>3/4</sup> "
MUH-40 & 50	30"	26 <sup>5/8</sup> "	17 <sup>1/8</sup> "

**SELECTION CHART**

CAT. NO.	VOLTS	ELECTRICAL DATA				CONTROL VOLT (1)	2 STAGE ELEMENT CONTROL	AIR DELIVERY DATA			FAN MOTOR DATA			MAXIMUM EFFECTIVE MOUNTING HEIGHT		HORI. AIR THROW	WIRE SIZE	INSTALLED WEIGHT (LBS.) W/BRACK.
		PHASE	KW	BTU/HR. 000	AMPS (3)			CFM(2)	FPM(2)	ΔT(°F)	VOLTS	RPM(2)	HP	HORIZ.	VERT.			
MUH-03-81	208	1Ø	3.0	10.2	14.5	208	N/A	350	800	27°	208	1600	1/100	8	9	12	AWG 12	27
MUH-03-21	208/240	1Ø	2.2/3.0	7.5/10.2	11.0/12.5	208/240	N/A	350	800	27°	208/240	1600	1/100	8	9	12	AWG 12	27
MUH-03-71	277	1Ø	3.0	10.2	11.0	277	N/A	350	800	27°	277	1600	1/100	8	9	12	AWG 14	27
MUH-03-31	347	1Ø	3.0	10.2	8.6	24	N/A	350	800	27°	347	1600	1/100	8	9	12	AWG 14	27
MUH-03-41	480	3Ø	3.0	10.2	3.6	24	N/A	350	800	27°	480	1600	1/100	8	9	12	AWG 14	27
MUH-03-61	600	3Ø	3.0	10.2	2.9	24	N/A	350	800	27°	600	1600	1/100	8	9	12	AWG 14	27
MUH-05-81	208	1-3Ø	5.0	17.0	24.0	208	5A	350	800	45°	208	1600	1/100	8	9	12	AWG 10	27
MUH-05-21	208/240	1-3Ø	3.75/5.0	12.6/17.0	18.0/21.0	208/240	5A	350	800	45°	208/240	1600	1/100	8	9	12	AWG 10	27
MUH-05-71	277	1Ø	5.0	17.0	18.0	277	N/A	350	800	45°	277	1600	1/100	8	9	12	AWG 10	27
MUH-05-31	347	1Ø	5.0	17.0	14.4	24	N/A	350	800	45°	347	1600	1/100	8	9	12	AWG 10	27
MUH-05-41	480	3Ø	5.0	17.0	6.0	24	N/A	350	800	45°	480	1600	1/100	8	9	12	AWG 14	27
MUH-05-61	600	3Ø	5.0	17.0	4.8	24	N/A	350	800	45°	600	1600	1/100	8	9	12	AWG 10	27
MUH-07-8	208	1-3Ø	7.5	25.6	36.0	24	5B	650	970	37°	208	1600	1/30	9	14	18	AWG 6	38
MUH-07-2	208/240	1-3Ø	5.6/7.5	19.1/25.6	27.0/31.3	24	5B	650	970	37°	208/240	1600	1/30	9	14	18	AWG 8	38
MUH-07-7	277	1Ø	7.5	25.6	27.0	24	5B	650	970	37°	277	1600	1/30	9	14	18	AWG 8	38
MUH-07-3	347	1Ø	7.5	25.6	21.6	24	5B	650	970	37°	347	1600	1/30	9	14	18	AWG 14	38
MUH-07-4	480	3Ø	7.5	25.6	9.0	24	5B	650	970	37°	480	1600	1/30	9	14	18	AWG 14	38
MUH-07-6	600	3Ø	7.5	25.6	7.3	24	5B	650	970	37°	600	1600	1/30	9	14	18	AWG 14	38
MUH-10-8	208	1-3Ø	10.0	34.1	48.0	24	5B	650	970	49°	208	1600	1/30	9	14	18	AWG 4	38
MUH-10-2	208/240	1-3Ø	7.5/10.0	25.6/34.1	36.0/42.0	24	5B	650	970	49°	208/240	1600	1/30	9	14	18	AWG 6	38
MUH-10-7	277	1Ø	10.0	34.1	36.0	24	5B	650	970	49°	277	1600	1/30	9	14	18	AWG 6	38
MUH-10-3	347	1Ø	10.0	34.1	28.8	24	5B	650	970	49°	347	1600	1/30	9	14	18	AWG 14	38
MUH-10-4	480	3Ø	10.0	34.1	12.0	24	5B	650	970	49°	480	1600	1/30	9	14	18	AWG 14	38
MUH-10-6	600	3Ø	10.0	34.1	9.7	24	5B	650	970	49°	600	1600	1/30	9	14	18	AWG 14	38
MUH-15-8	208	1-3Ø	15.0	51.2	72.0	24	5A	910	1640	52°	208	1530	1/20	11	20	35	AWG 2	53
MUH-15-2	208/240	3Ø	11.2/15.0	38.2/51.2	31.3/36.1	24	5C	910	1640	52°	208/240	1530	1/20	11	20	35	AWG 6	53
MUH-15-4	480	3Ø	15.0	51.2	18.0	24	5C	910	1640	52°	480	1530	1/20	11	20	35	AWG 10	53
MUH-15-6	600	3Ø	15.0	51.2	14.5	24	5C	910	1640	52°	600	1530	1/20	11	20	35	AWG 12	53
MUH-20-8	208	3Ø	20.0	68.2	56.0	24	5A	1320	2060	48°	208	1500	1/10	12	23	41	AWG 4	60
MUH-20-2	208/240	3Ø	15.0/20.0	51.2/68.2	41.2/48.0	24	5C	1320	2060	48°	208/240	1500	1/10	12	23	41	AWG 4	60
MUH-20-4	480	3Ø	20.0	68.2	24.0	24	5C	1320	2060	48°	480	1500	1/10	12	23	41	AWG 10	60
MUH-20-6	600	3Ø	20.0	68.2	19.3	24	5C	1320	2060	48°	600	1500	1/10	12	23	41	AWG 12	60
MUH-25-2	208/240	3Ø	18.7/25.0	63.8/85.2	52.0/60.0	24	5A	2100/1800	2100/2030	38°/44°	208/240	1600/1375	1/4	13	23	50	AWG 3	93
MUH-25-4	480	3Ø	25.0	85.2	30.0	24	5C	2100/1800	2100/2030	38°/44°	480	1600/1375	1/4	13	23	50	AWG 8	93
MUH-25-6	600	3Ø	25.0	85.2	24.2	24	5C	2100/1800	2100/2030	38°/44°	600	1600/1375	1/4	13	23	50	AWG 10	93
MUH-30-8	208	3Ø	30.0	102.3	84.0	24	5A	2100/1800	2100/2030	45°/53°	208	1600/1375	1/4	12	20	50	AWG 1	93
MUH-30-2	208/240	3Ø	22.5/30.0	76.7/102.3	63.0/72.3	24	5A	2100/1800	2100/2030	45°/53°	208/240	1600/1375	1/4	12	20	50	AWG 2	93
MUH-30-4	480	3Ø	30.0	102.3	36.0	24	5C	2100/1800	2100/2030	45°/53°	480	1600/1375	1/4	12	20	50	AWG 6	93
MUH-30-6	600	3Ø	30.0	102.3	29.0	24	5C	2100/1800	2100/2030	45°/53°	600	1600/1375	1/4	12	20	50	AWG 8	93
MUH-40-2	208/240	3Ø	30.0/40.0	102.3/136.4	83.4/96.4	24	5A	3000/2600	3260/2900	42°/49°	208/240	1525/1420	1/2	15	28	60	AWG 1/0	114
MUH-40-4	480	3Ø	40.0	136.4	48.0	24	5A	3000/2600	3260/2900	42°/49°	480	1525/1420	1/2	15	28	60	AWG 4	114
MUH-40-6	600	3Ø	40.0	136.4	38.7	24	5A	3000/2600	3260/2900	42°/49°	600	1525/1420	1/2	15	28	60	AWG 6	114
MUH-50-8	208	3Ø	50.0	170.5	139.0	24	5A	3000/2600	3260/2900	53°/61°	208	1525/1420	1/2	15	25	60	AWG 4/0	114
MUH-50-2	208/240	3Ø	37.5/50.0	127.3/170.5	104.2/120.4	24	5A	3000/2600	3260/2900	53°/61°	208/240	1525/1420	1/2	15	25	60	AWG 3/0	114
MUH-50-4	480	3Ø	50.0	170.5	60.2	24	5A	3000/2600	3260/2900	53°/61°	480	1525/1420	1/2	15	25	60	AWG 4	114
MUH-50-6	600	3Ø	50.0	170.5	48.3	24	5A	3000/2600	3260/2900	53°/61°	600	1525/1420	1/2	15	25	60	AWG 3	114

**Note:**

- All standard units are supplied with a low voltage control transformer and contactor (24V) except MUH-03 & 05, 208, 240 & 277 volt models. Low voltage control on these units are available on made to order. All units are also available on special order for 120 volt control; internal and transformer or external without transformer.
- On dual voltage units; CFM, FPM, and RPM are shown at higher voltage.
- On dual phase units, maximum amp draw is listed for respective voltage.
- 25 thru 50 KW models have two speed motors and dual CFM ratings.
- 5A. Standard.
- 5B. Optional - made to order - amp load unbalanced on 3 Phase.
- 5C. Optional - made to order - amp load balanced on 3 Phase.

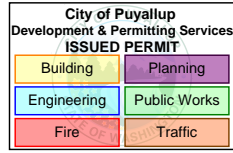

# MUH SERIES UNIT HEATER

DIMENSIONS			
CATALOG NO.	HEIGHT (IN)	WIDTH (IN)	DEPTH (IN)
MUH03 & 05	16	14	7-1/2
MUH07 & 10	21-3/4	19	7-1/2
MUH15 & 20	21-3/4	19	12-3/4
MUH25 & 30	30	26-5/8	11-3/4
MUH40 & 50	30	26-5/8	17-1/8

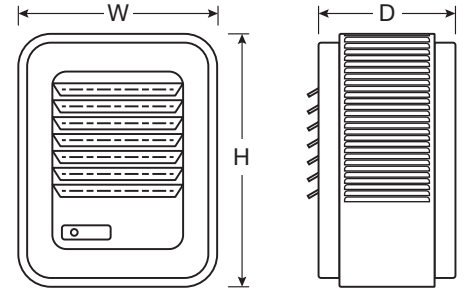

OPTIONAL FIELD-INSTALLED CONTROLS				
CATALOG NO.	UPC	DESCRIPTION	ELECTRICAL RATING	COMPATIBLE WITH
UHMT1	6 85360 15241 7	Single Pole Internal Thermostat-Temp Range: 40°- 85°F	25A @ 120, 240VAC Res. 22A @ 277VAC Res.	All MUH Series Heaters (except MUH0521 3 PH, MUH0581 3 PH which use UHMT2)
UHMT2	6 85360 15242 4	Two Stage Internal Thermostat-Temp Range: 40°- 85°F	25A @ 120, 240VAC Res. 22A @ 277VAC Res. 125VA	MUH0521 3 PH, MUH0581 3 PH, MUH158, MUH208, MUH252, MUH302, MUH308, MUH402, MUH404, MUH406, MUH502, MUH504, MUH506, MUH508
MCFS	6 85360 04637 2	Internal Summer Fan Switch 250, 480, 600V.A.C. 1,2 OR 3 PH	Pilot Duty 6A, 600VAC Res. 2 HP	All MUH Series Heaters
MRFS1	6 85360 04708 9	Remote Summer Fan Switch (Line Voltage)	2 HP, 250-480VAC	All MUH Series Heaters
MRFS2	6 85360 04709 6	Remote Summer Fan Switch with Relay (24V Coil-Single Pole Normally Open)	6 AFL, 35 ALR, 250VAC, 60Hz 3 AFL, 18 ALR, 480VAC, 60Hz	All MUH Series Heaters (except MUH0321, MUH0371, MUH0381, MUH0521, MUH0571, MUH0581) Units unless optional control transformer is supplied
MHRT	6 85360 04694 5	Heat Recovery Thermostat with Relay (24V Coil-Single Pole Normally Open) Hi - 120°F, Low - 60°F	6 AFL, 35 ALR, 250VAC, 60Hz 3 AFL, 18 ALR, 480VAC, 60Hz	All MUH Series Heaters (except MUH0321, MUH0371, MUH0381, MUH0521, MUH0571, MUH0581) Units unless optional control transformer is supplied
MPDS25	6 85360 04703 4	Power Disconnect Switch (3-Pole)	30A @ 600VAC, Res.	MUH0321, MUH0341, MUH0371, MUH0381, MUH0521, MUH0541, MUH0571, MUH0581, MUH073, MUH074, MUH076, MUH104, MUH106, MUH154, MUH156, MUH204, MUH206
MPDS60	6 85360 04704 1	Power Disconnect Switch (3-Pole)	80A @ 600VAC, Res.	MUH072, MUH077, MUH078, MUH102, MUH103, MUH107, MUH108, MUH152, MUH202, MUH208, MUH252, MUH254, MUH256, MUH304, MUH306, MUH404, MUH406, MUH504, MUH506

NOTE: Any field installed options assembled in the factory require added surcharge. See price book for charges. MPDS60 disconnect switch is not suitable for field installation on 7.5kw and 10kw unit heaters.

DIFFUSER SELECTOR TABLES FOR VERTICAL MOUNTING					
CATALOG NO.	DESCRIPTION	CATALOG NO.	MAX. MOUNTING HEIGHT	(A) DIMENSION	DIFFUSER PATTERN AND AREA
NONE	WITHOUT DIFFUSER No diffuser needed where a straight downflow air pattern is required. For maximum air throw, remove louvers. Any of three diffusers can be added to basic heater.	MUH03 & MUH05	9	18 26	
NONE		MUH07 & MUH10	14	35 40	
NONE		MUH15	20	63 55	
NONE		MUH20	23	70 63	
NONE		MUH25	20		
NONE		MUH30	20		
MLDS	LOUVER DIFFUSER Permits directional (straight line) air flow as in air curtain application over doorways. Rectangular coverage, Louvers can be turned in either direction.	MUH03 & MUH05	9	25(A) 12(B)	
MLDM		MUH07 & MUH10	14	39(A) 19(B)	
MLDM		MUH15	18	50(A) 25(B)	
MLDM		MUH20	20	56(A) 28(B)	
MLDL		MUH25	23	72(A) 36(B)	
MLDL		MUH30	20		
MLDL		MUH40	24	88(A) 44(B)	
MLDL		MUH50	22	80(A) 40(B)	

# MUH SERIES UNIT HEATER

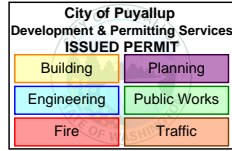

## OPTIONAL MOUNTING BRACKETS

CATALOG NO.	UPC	COMPATIBLE WITH	SHIP WT. (LBS)
B10	6 85360 15229 5	MUH03 - 10	8
B20	6 85360 15230 1	MUH15 & 20	10
B30	6 85360 15231 8	MUH25 & 30	13
B50	6 85360 15232 5	MUH40 & 50	15

## OPTIONAL CEILING MOUNTING BRACKETS

CATALOG NO.	UPC	COMPATIBLE WITH	SHIP WT. (LBS)
CMB10	6 85360 15236 3	MUH03 - 10	3
CMB20	6 85360 15237 0	MUH15 & 20	4
CMB30	6 85360 15238 7	MUH25 & 30	5
CMB50	6 85360 15239 4	MUH40 & 50	6

## OPTIONAL VERTICAL CEILING MOUNTING BRACKETS

CATALOG NO.	UPC	COMPATIBLE WITH	SHIP WT. (LBS)
VDMB5	6 85360 15245 5	MUH03 - 05	5
VDMB20	6 85360 15246 2	MUH07 - 20	7
VDMB50	6 85360 15247 9	MUH25 - 50	9

**MOUNTING LIMITATIONS:** Unit heaters should not be used in potentially explosive atmospheres. The finish is not intended for direct salt spray exposure in marine applications or the highly corrosive atmospheres of swimming pools, chemical storage bins, etc. Do not install unit heaters above recommended maximum mounting height. Obstructions must not block unit heater air inlet or discharge. Heaters must be mounted at least 7 ft. above the floor to prevent accidental contact with the heating element or fan blade which could cause injury.

## FACTORY-INSTALLED OPTIONS FOR CONTROLS & ACCESSORIES

DESCRIPTION
MUH03 & 05 (208, 208/240, 277V Supply) 24 or 120V Control Transformer and Power Contactor 24 or 120V H.C. Power Contactor
MUH03 & 05 (480V Supply) & MUH07 thru MUH50 Optional 120V Control
2-Stage Control of Elements (See Note 5)
Manual Reset
Outlet Mesh (Bird Screen) For all MUH Heaters

NOTE: Any factory-installed options require added surcharge. See price book for charges or contact factory.

## BRACKET SIZE

DIMENSION	3-20 kW (IN.)	25-50 kW (IN.)
A	7-1/4	9-7/16
B	9-1/2	14-3/8
C	7-1/4	12-1/8
D	11-5/16	2-1/16
E	2-1/4	3
L	20-1/2	28-15/16
M	9-15/16	14-15/16
N	3-1/4	4-1/2

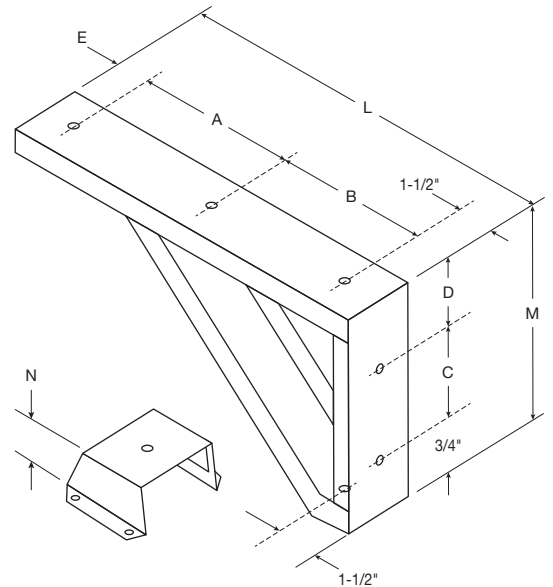
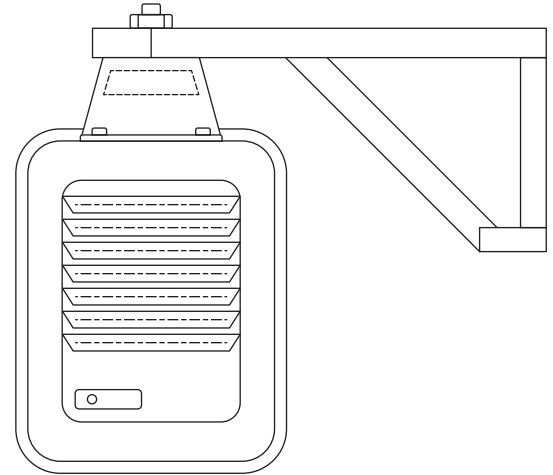

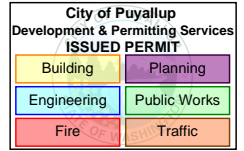

## Heavy Duty Grilles

Model: XG-4538S Steel Heavy Duty Gym Return Grille Horizontal Blades 38 Degree Deflection

### Dimensions

ID#	Tag	Qty	Model	Neck 1	Neck 2	Round Neck (in.)
9-1		1	XG-4538S	12	14	N/A

### Note:

- Quantities and Sizes listed are for submittal purposes only, to be verified prior to order
- Submittal information is deemed correct at time of printing, however in the interest of product improvement Greenheck reserves the right to make changes without notice.

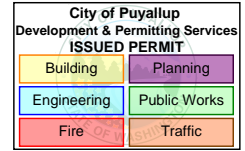

## Heavy Duty Grilles

Model: XG-4538S Steel Heavy Duty Gym Return Grille Horizontal Blades 38 Degree Deflection

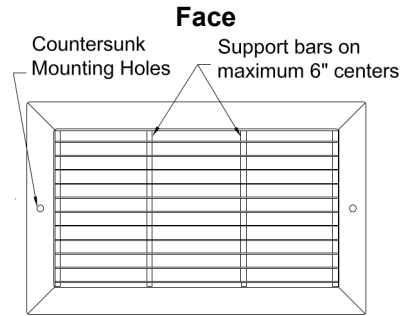
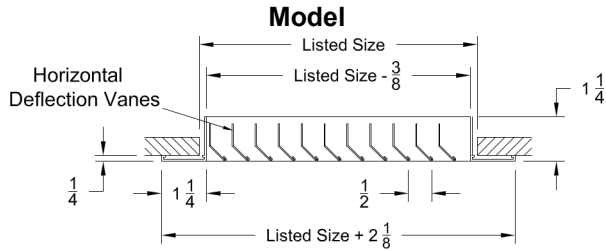

### Construction

ID#	Border Type	Finish Color
9-1	Flush Surface Mount	White

### Accessories

ID#	Damper	Screw Holes	Grid	Plaster Frame	Insect Screen	Transition
9-1	None	Yes	None	None	No	None

### Included

ID#	Tag	Qty	Neck 1	Neck 2	Round Neck
9-1		1	12	14	N/A