

NOTES:  
 1. INSTALLATION TO BE COMPLETED IN ACCORDANCE WITH MANUFACTURER'S SPECIFICATIONS.  
 2. DO NOT SCALE DRAWINGS.

**2** SILVA CELLS UNDER PARKING BAYS AT PLANTER ISLAND  
 NTS

**3** STEEL LAWN EDGING  
 NTS

**1** SILVA CELL LAYOUT PLAN  
 1" = 20'  
 P-2023-PSE-21

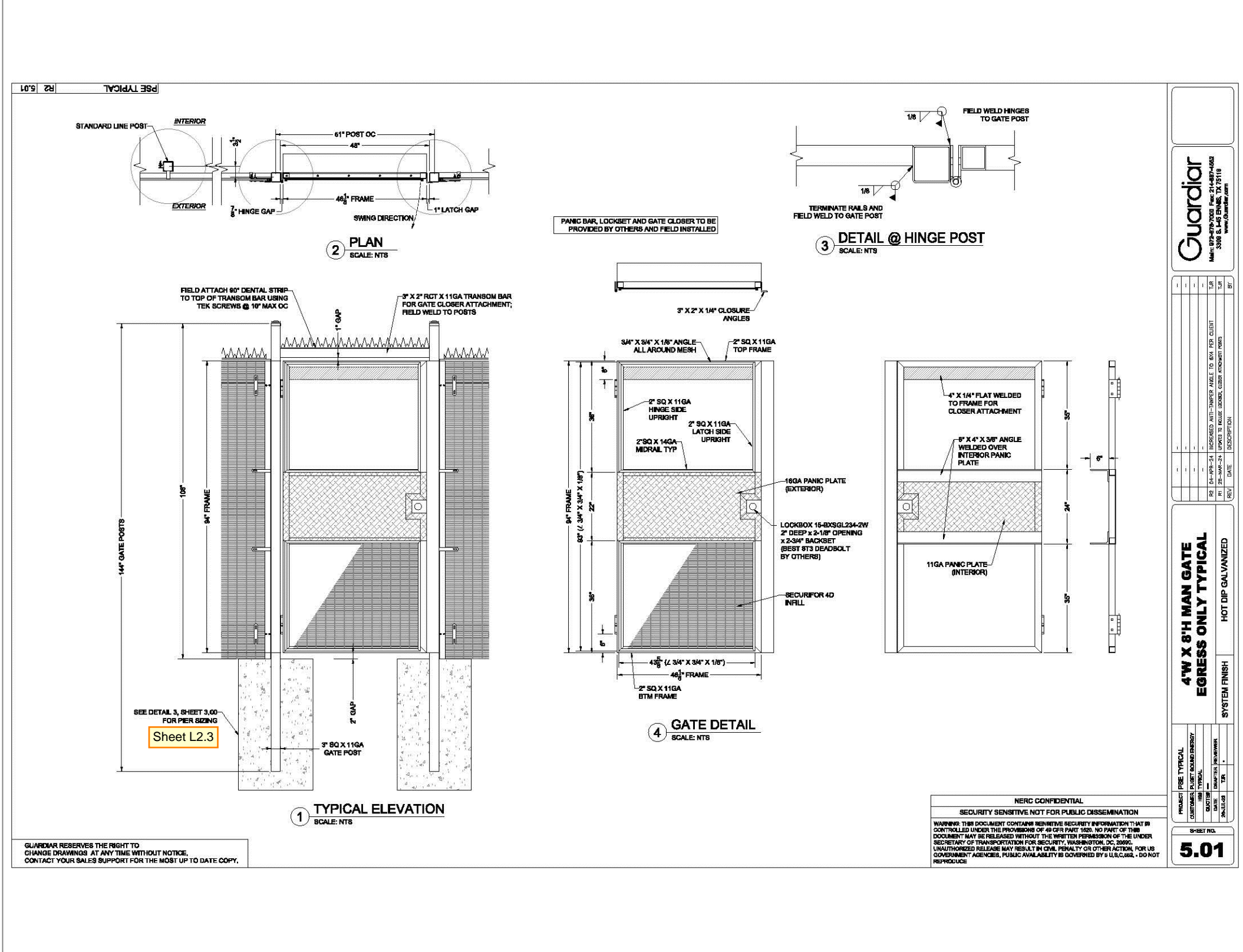

**2** PEDESTRIAN GATE DETAIL  
 1" = 1"  
 P-2023-PSE-55

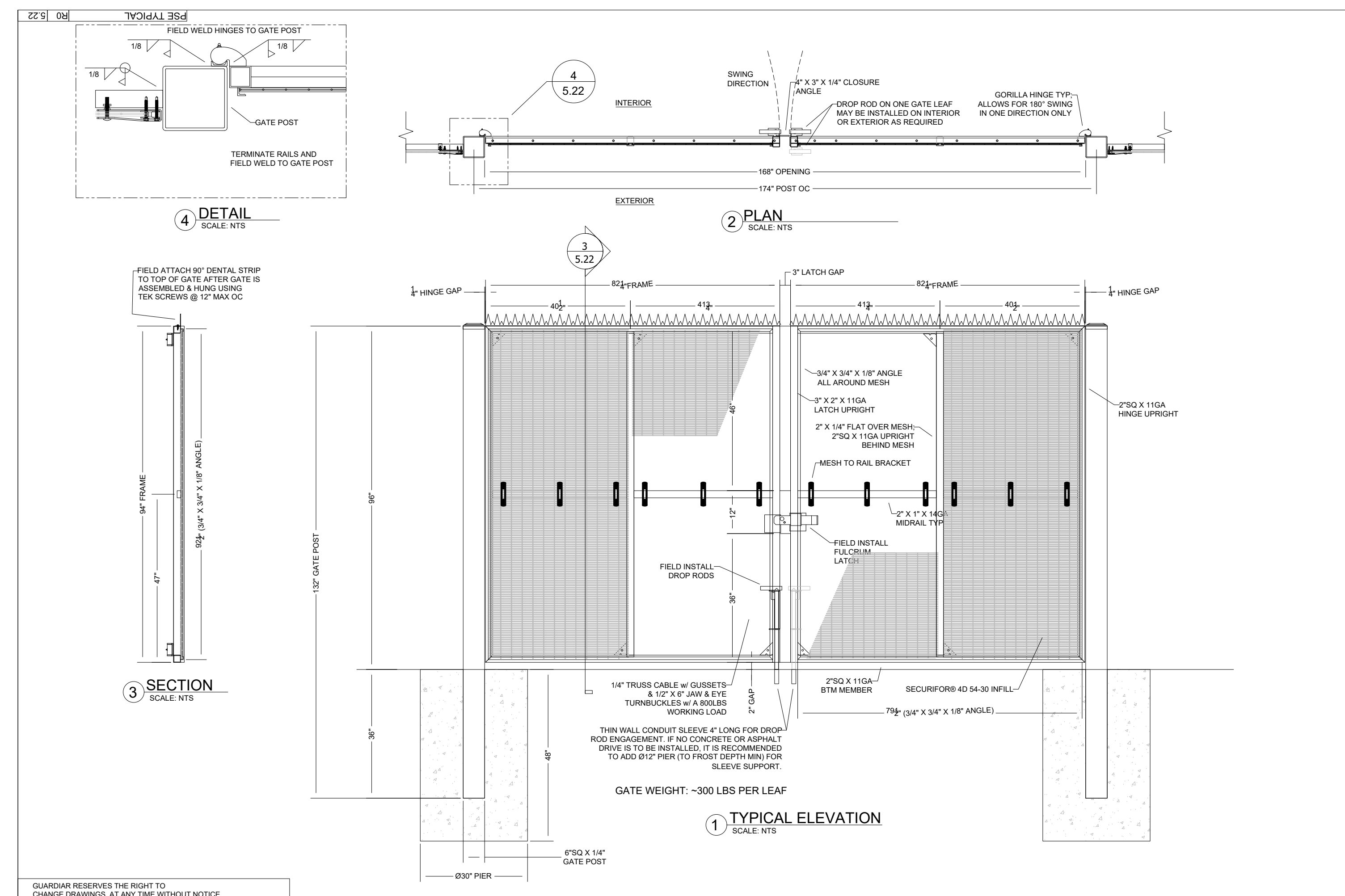

**5** DOUBLE SWING GATE DETAIL  
 1" = 1"  
 P-2023-PSE-56



**100% CD Set**

REV	ISSUED FOR	DATE
1	PERMIT COMMENTS	05.29.24
2	FENCE UPDATES	07.11.24
3	FENCE UPDATES	11.19.24

SCALE: NTS

**PSE - OPERATIONAL TRAINING CENTER**

**DETAIL SHEET**

PROJECT No: 202202.06  
 DRAWN BY: SPW  
 CHECKED BY: PLA  
 DATE ISSUED: 07/11/24

Welding to be completed by an individual or fabricator who is WABO certified or approved by the Building Official to perform the work. All welds must be inspected and approved by a WABO certified special inspector.

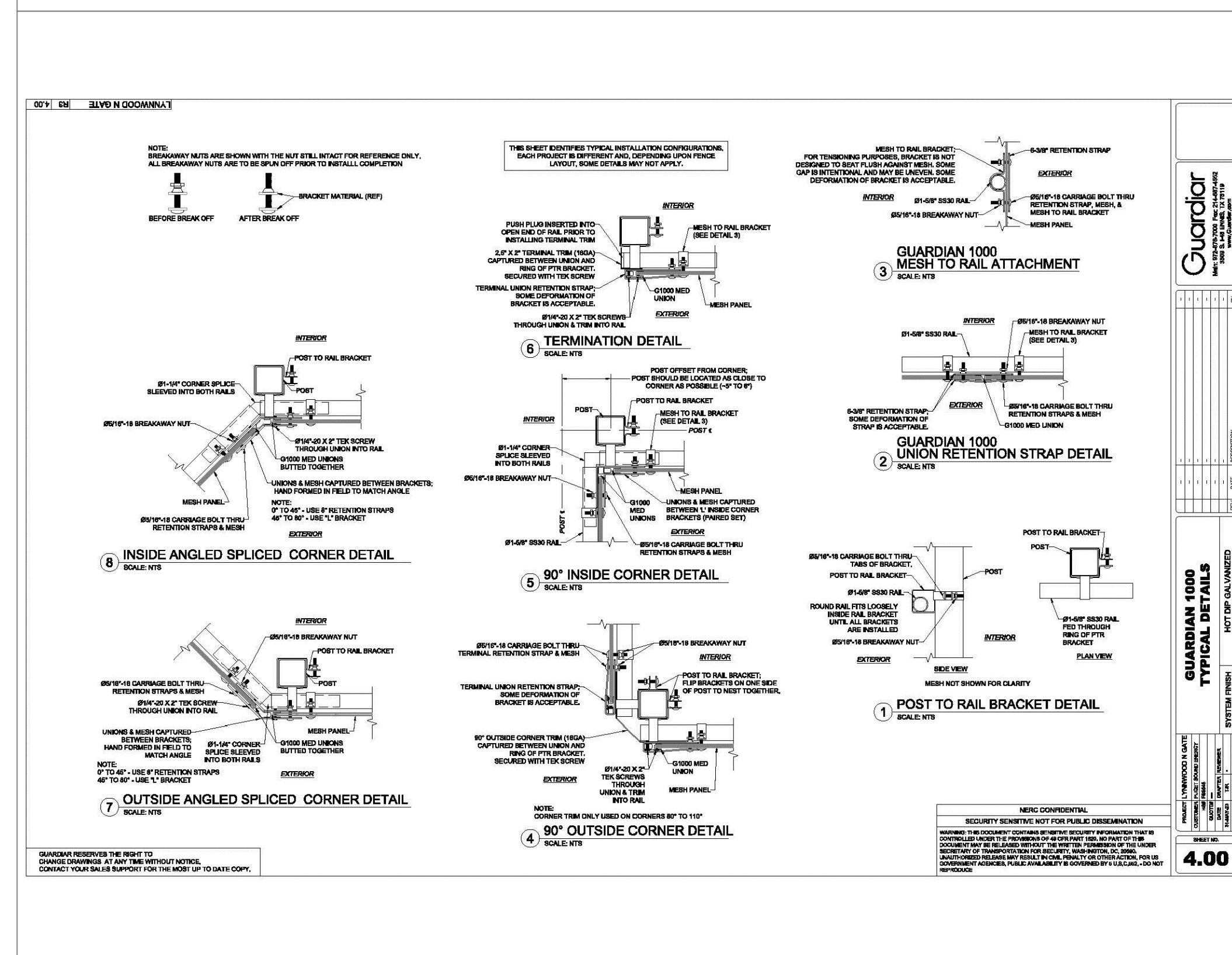
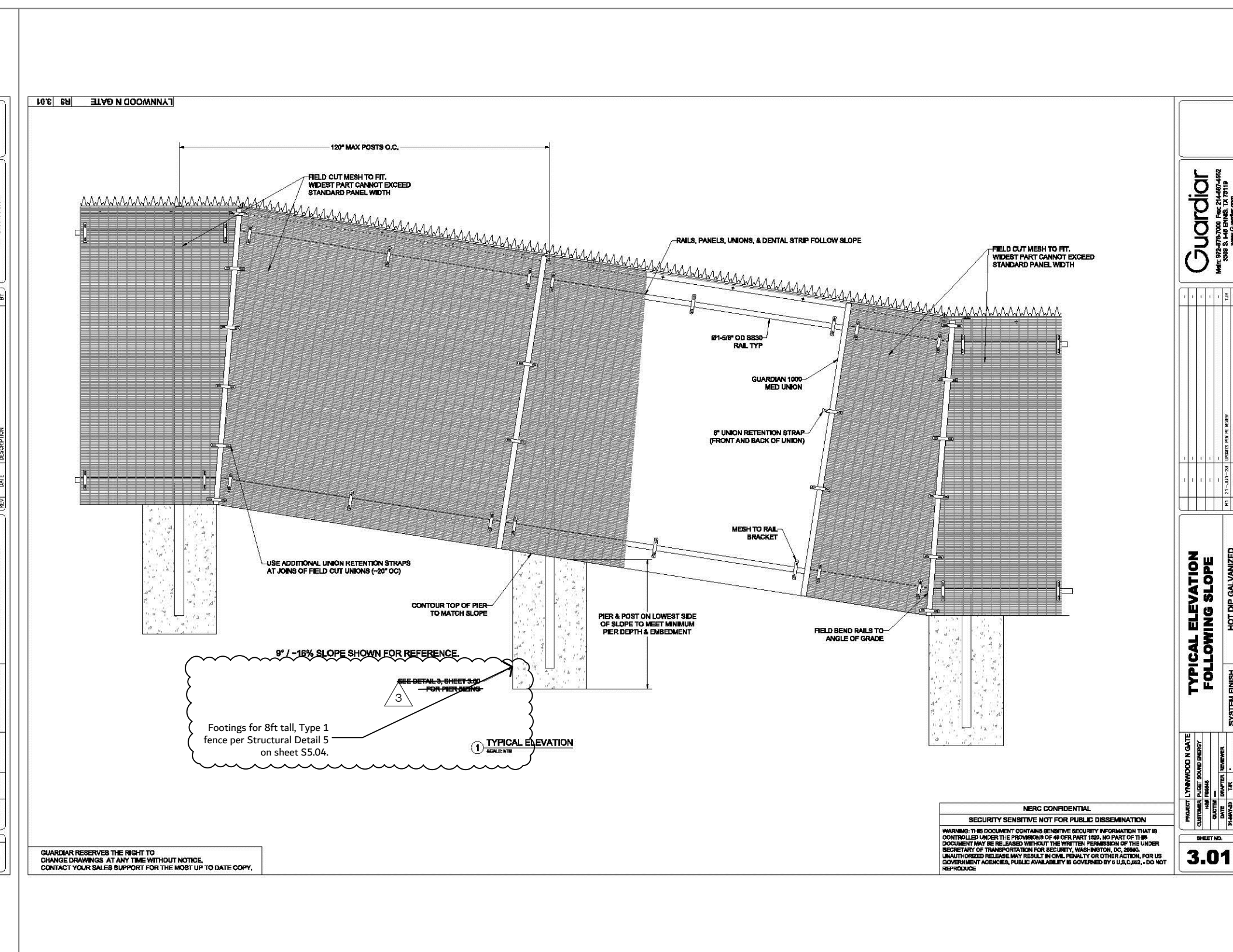
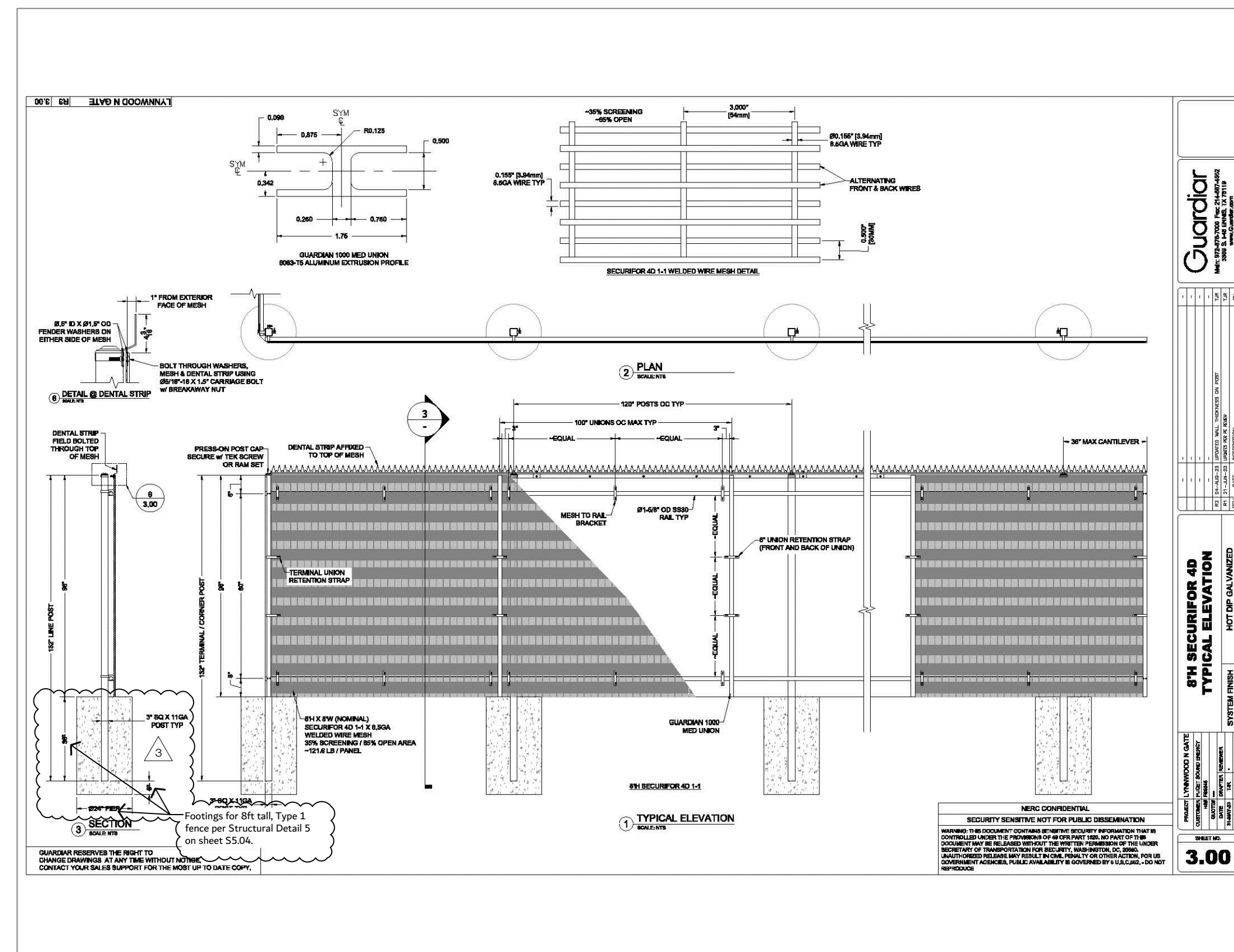
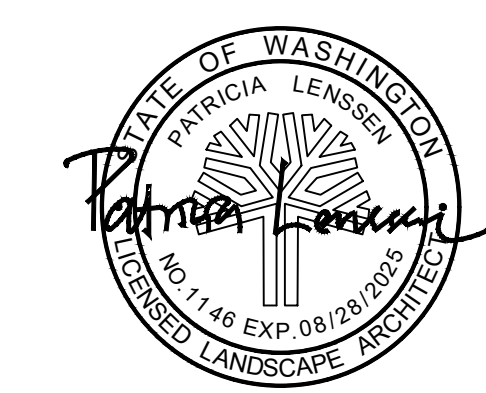

**1** TYPE 1 FENCE DETAILS  
1" = 1"

**100% CD Set**

REV	ISSUED FOR	DATE
1	PERMIT COMMENTS	05.29.24
2	FENCE UPDATES	07.11.24
3	FENCE UPDATES	11.19.24

SCALE: NTS

**PSE - OPERATIONAL TRAINING CENTER**

**DETAIL SHEET**

PROJECT No:	202202.06
DRAWN BY:	SPW
CHECKED BY:	PLA
DATE ISSUED:	07/11/24

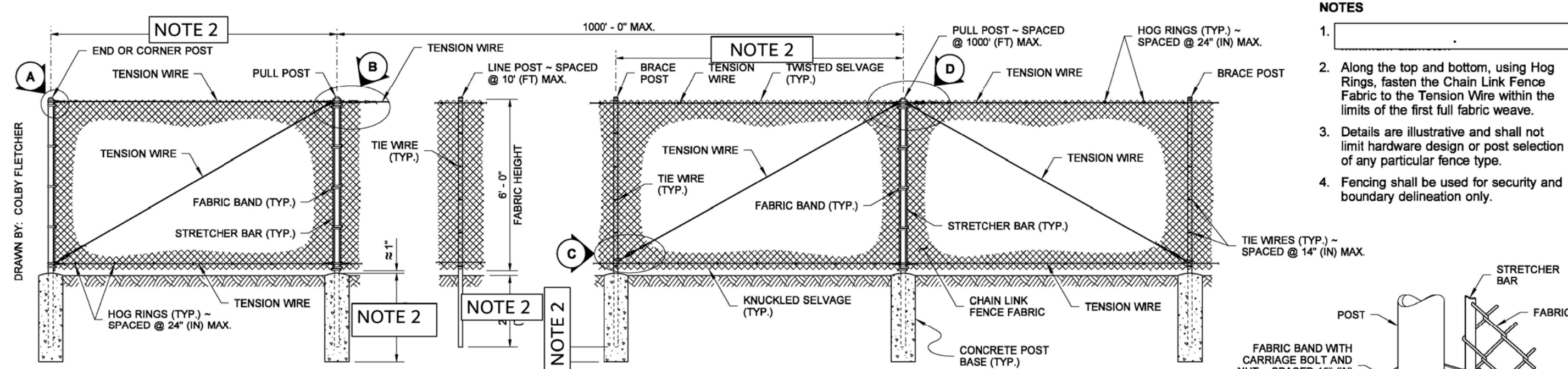

- NOTES**
1. [Blank]
  2. Along the top and bottom, using Hog Rings, fasten the Chain Link Fence Fabric to the Tension Wire within the limits of the first full fabric weave.
  3. Details are illustrative and shall not limit hardware design or post selection of any particular fence type.
  4. Fencing shall be used for security and boundary delineation only.

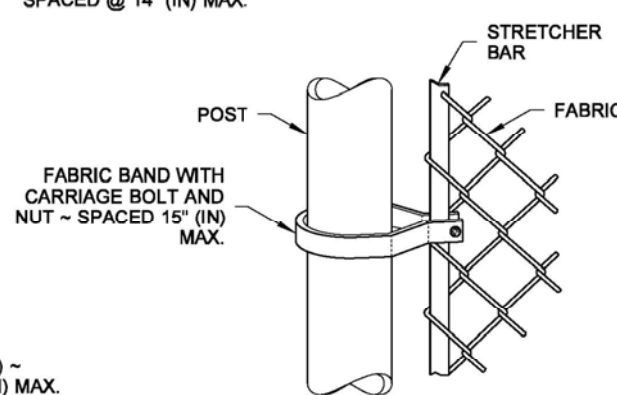

METHOD OF FASTENING STRETCHER BAR TO POST

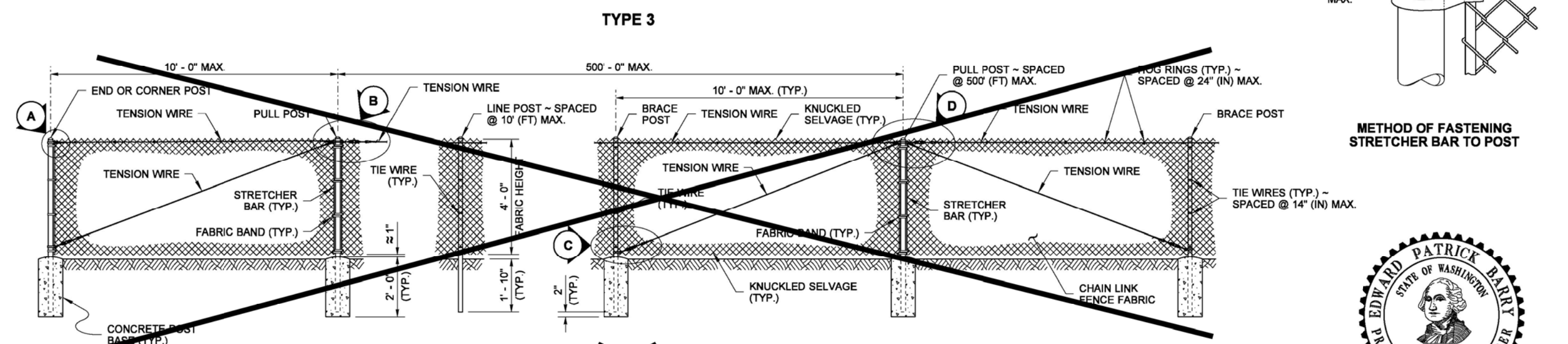

POST AND RAIL SPECIFICATIONS				
POST	PIPE	ROLL FORMED		
	NOM. SIZE (SCH. 40) I.D.	SECTION	WEIGHT (lb/ft)	
END, CORNER, OR PULL POST	2 1/2" DIAM.	(Y)	5.10	
LINE OR BRACE POST	2" DIAM.	(Z)	1.85	

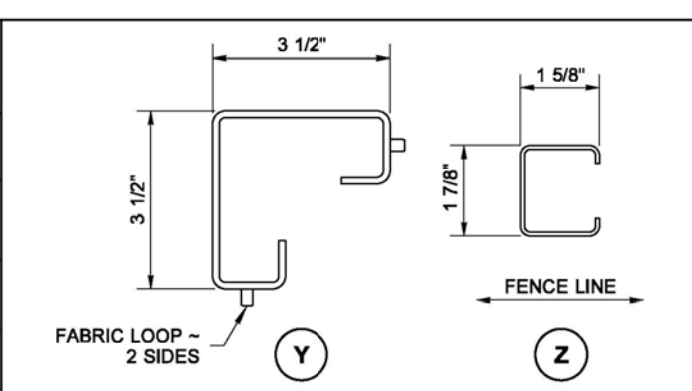

- NOTES FOR PSE OTC PROJECT:**
1. TYPE 2 FENCE HEIGHT IS 7'-0" AND IS CONSTRUCTED PER TYPE 3 FENCE DETAIL. POST FOOTING AND SPACING SHALL BE BIDDER DESIGNED AND ENGINEERED. SEE SPECIFICATIONS.
  2. CHAIN LINK FABRIC FOR TYPE 2 AND TYPE 3 FENCE IS PER THIS DETAIL.

**CHAIN LINK FENCE TYPES 3 AND 4**  
**STANDARD PLAN L-20.10-03**  
SHEET 1 OF 2 SHEETS  
APPROVED FOR PUBLICATION  
STATE DESIGN ENGINEER  
Washington State Department of Transportation

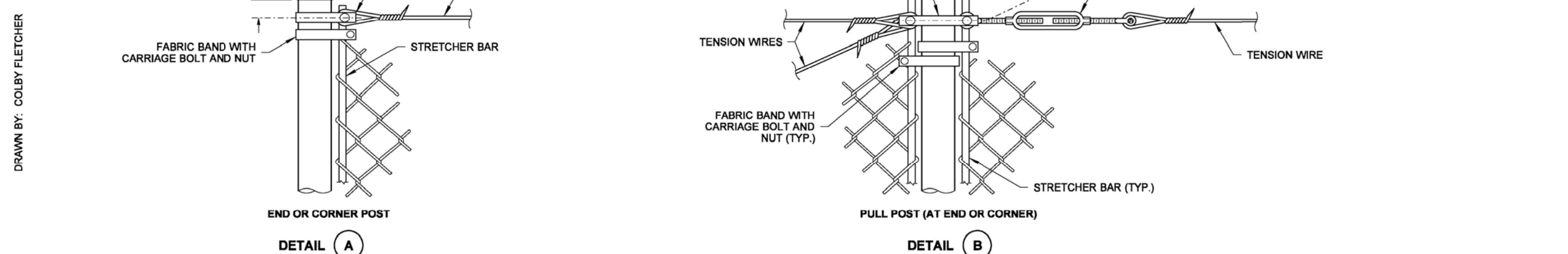

DETAIL A

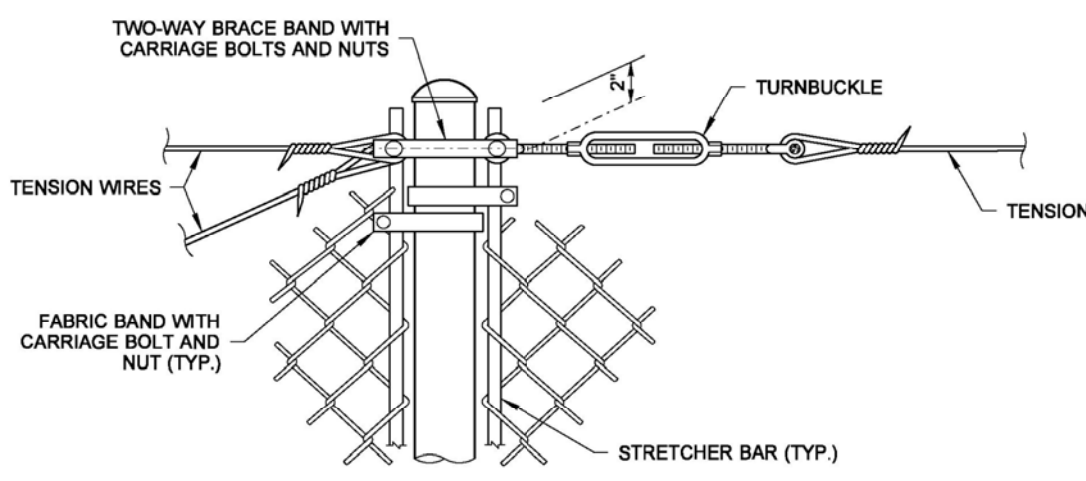

DETAIL B

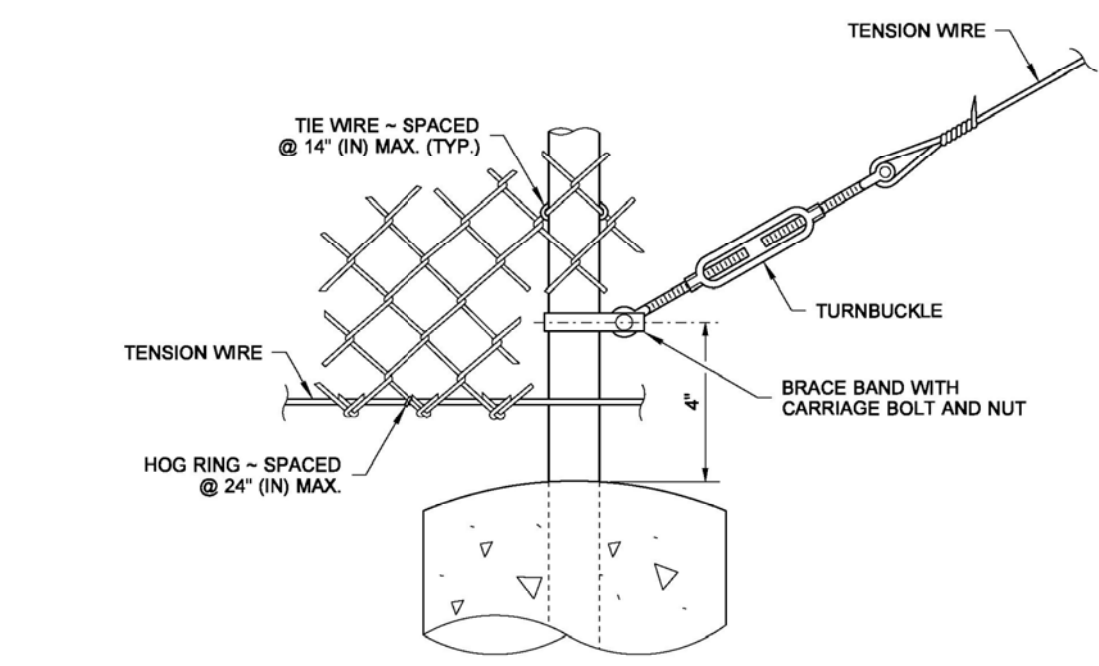

DETAIL C

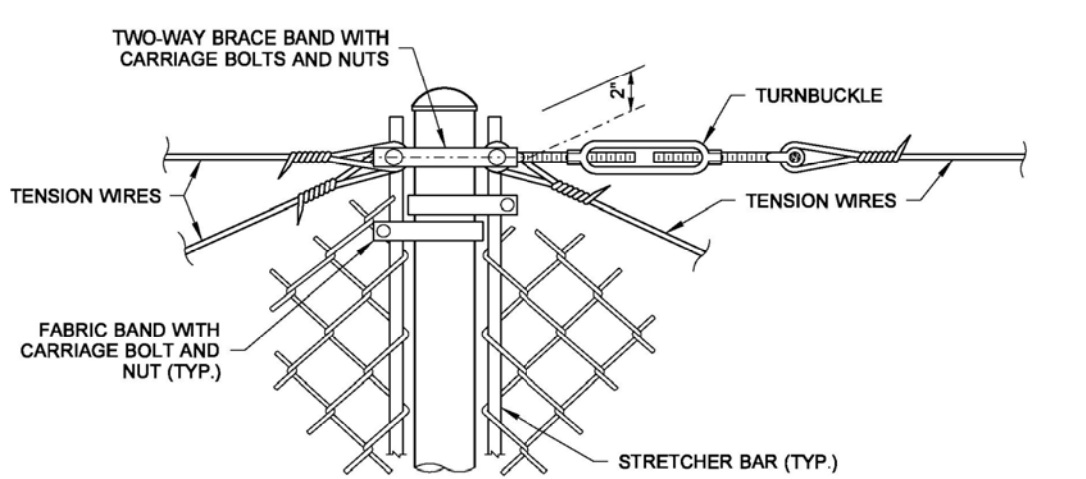

DETAIL D



**CHAIN LINK FENCE TYPES 3 AND 4**  
**STANDARD PLAN L-20.10-03**  
SHEET 2 OF 2 SHEETS  
APPROVED FOR PUBLICATION  
STATE DESIGN ENGINEER  
Washington State Department of Transportation

**1 CHAIN LINK FENCE WSDOT STANDARD DETAIL**  
NTS

**100% CD Set**

REV	ISSUED FOR	DATE
1	PERMIT COMMENTS	05.29.24

SCALE: NTS

**PSE - OPERATIONAL TRAINING CENTER**

**DETAIL SHEET**

PROJECT No:	202202.06
PREPARED BY:	SPW
CHECKED BY:	PLA
DATE ISSUED:	04/26/24

**L2.4**  
© 2022

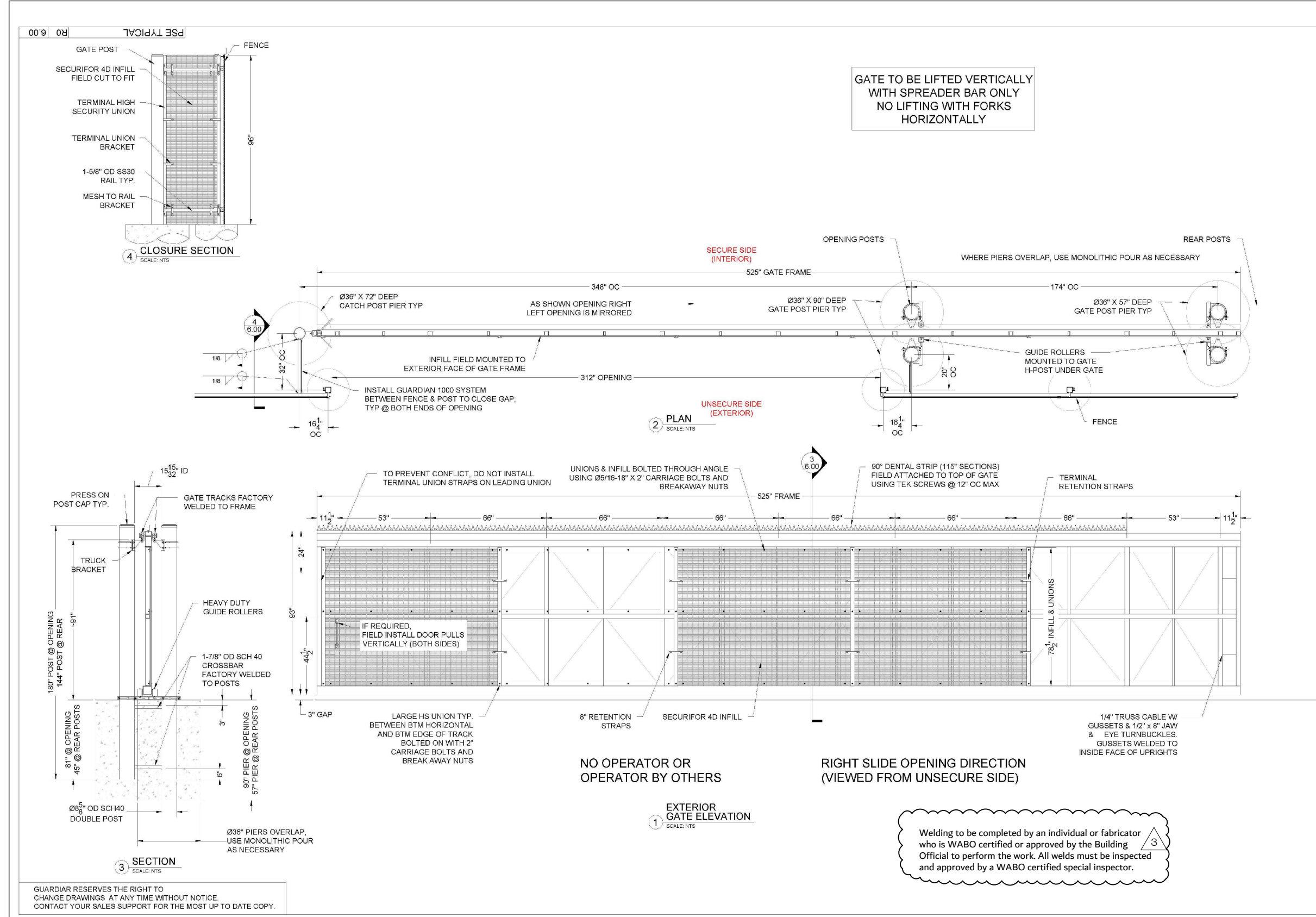

PROJECT NO.	202202.06
DATE	07/11/24
PROJECT NAME	PSE TYPICAL
DATE	07/11/24
PROJECT LOCATION	1814 BROADWAY ST., BELLINGHAM, WA 98225
DATE	07/11/24
PROJECT TYPE	PERMITTING
DATE	07/11/24
PROJECT NO.	202202.06
DATE	07/11/24
PROJECT NAME	PSE TYPICAL
DATE	07/11/24
PROJECT LOCATION	1814 BROADWAY ST., BELLINGHAM, WA 98225
DATE	07/11/24
PROJECT TYPE	PERMITTING
DATE	07/11/24
PROJECT NO.	202202.06
DATE	07/11/24
PROJECT NAME	PSE TYPICAL
DATE	07/11/24
PROJECT LOCATION	1814 BROADWAY ST., BELLINGHAM, WA 98225
DATE	07/11/24
PROJECT TYPE	PERMITTING
DATE	07/11/24
PROJECT NO.	202202.06
DATE	07/11/24
PROJECT NAME	PSE TYPICAL
DATE	07/11/24
PROJECT LOCATION	1814 BROADWAY ST., BELLINGHAM, WA 98225
DATE	07/11/24
PROJECT TYPE	PERMITTING
DATE	07/11/24
PROJECT NO.	202202.06
DATE	07/11/24
PROJECT NAME	PSE TYPICAL
DATE	07/11/24
PROJECT LOCATION	1814 BROADWAY ST., BELLINGHAM, WA 98225
DATE	07/11/24
PROJECT TYPE	PERMITTING
DATE	07/11/24
PROJECT NO.	202202.06
DATE	07/11/24
PROJECT NAME	PSE TYPICAL
DATE	07/11/24
PROJECT LOCATION	1814 BROADWAY ST., BELLINGHAM, WA 98225
DATE	07/11/24
PROJECT TYPE	PERMITTING
DATE	07/11/24
PROJECT NO.	202202.06
DATE	07/11/24
PROJECT NAME	PSE TYPICAL
DATE	07/11/24
PROJECT LOCATION	1814 BROADWAY ST., BELLINGHAM, WA 98225
DATE	07/11/24
PROJECT TYPE	PERMITTING
DATE	07/11/24
PROJECT NO.	202202.06
DATE	07/11/24
PROJECT NAME	PSE TYPICAL
DATE	07/11/24
PROJECT LOCATION	1814 BROADWAY ST., BELLINGHAM, WA 98225
DATE	07/11/24
PROJECT TYPE	PERMITTING
DATE	07/11/24
PROJECT NO.	202202.06
DATE	07/11/24
PROJECT NAME	PSE TYPICAL
DATE	07/11/24
PROJECT LOCATION	1814 BROADWAY ST., BELLINGHAM, WA 98225
DATE	07/11/24
PROJECT TYPE	PERMITTING
DATE	07/11/24
PROJECT NO.	202202.06
DATE	07/11/24
PROJECT NAME	PSE TYPICAL
DATE	07/11/24
PROJECT LOCATION	1814 BROADWAY ST., BELLINGHAM, WA 98225
DATE	07/11/24
PROJECT TYPE	PERMITTING
DATE	07/11/24
PROJECT NO.	202202.06
DATE	07/11/24
PROJECT NAME	PSE TYPICAL
DATE	07/11/24
PROJECT LOCATION	1814 BROADWAY ST., BELLINGHAM, WA 98225
DATE	07/11/24
PROJECT TYPE	PERMITTING
DATE	07/11/24

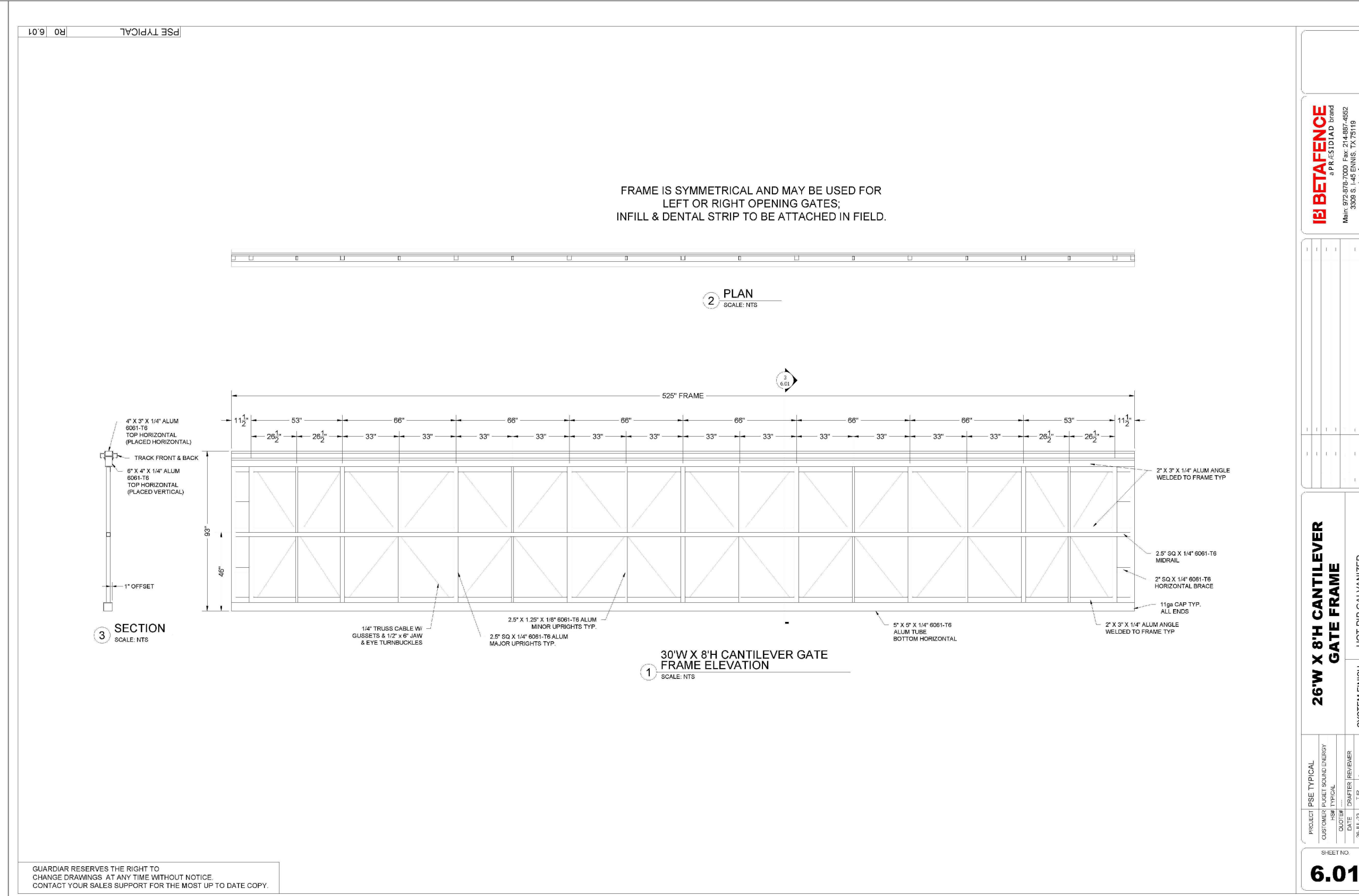

PROJECT NO.	202202.06
DATE	07/11/24
PROJECT NAME	PSE TYPICAL
DATE	07/11/24
PROJECT LOCATION	1814 BROADWAY ST., BELLINGHAM, WA 98225
DATE	07/11/24
PROJECT TYPE	PERMITTING
DATE	07/11/24
PROJECT NO.	202202.06
DATE	07/11/24
PROJECT NAME	PSE TYPICAL
DATE	07/11/24
PROJECT LOCATION	1814 BROADWAY ST., BELLINGHAM, WA 98225
DATE	07/11/24
PROJECT TYPE	PERMITTING
DATE	07/11/24
PROJECT NO.	202202.06
DATE	07/11/24
PROJECT NAME	PSE TYPICAL
DATE	07/11/24
PROJECT LOCATION	1814 BROADWAY ST., BELLINGHAM, WA 98225
DATE	07/11/24
PROJECT TYPE	PERMITTING
DATE	07/11/24
PROJECT NO.	202202.06
DATE	07/11/24
PROJECT NAME	PSE TYPICAL
DATE	07/11/24
PROJECT LOCATION	1814 BROADWAY ST., BELLINGHAM, WA 98225
DATE	07/11/24
PROJECT TYPE	PERMITTING
DATE	07/11/24
PROJECT NO.	202202.06
DATE	07/11/24
PROJECT NAME	PSE TYPICAL
DATE	07/11/24
PROJECT LOCATION	1814 BROADWAY ST., BELLINGHAM, WA 98225
DATE	07/11/24
PROJECT TYPE	PERMITTING
DATE	07/11/24
PROJECT NO.	202202.06
DATE	07/11/24
PROJECT NAME	PSE TYPICAL
DATE	07/11/24
PROJECT LOCATION	1814 BROADWAY ST., BELLINGHAM, WA 98225
DATE	07/11/24
PROJECT TYPE	PERMITTING
DATE	07/11/24

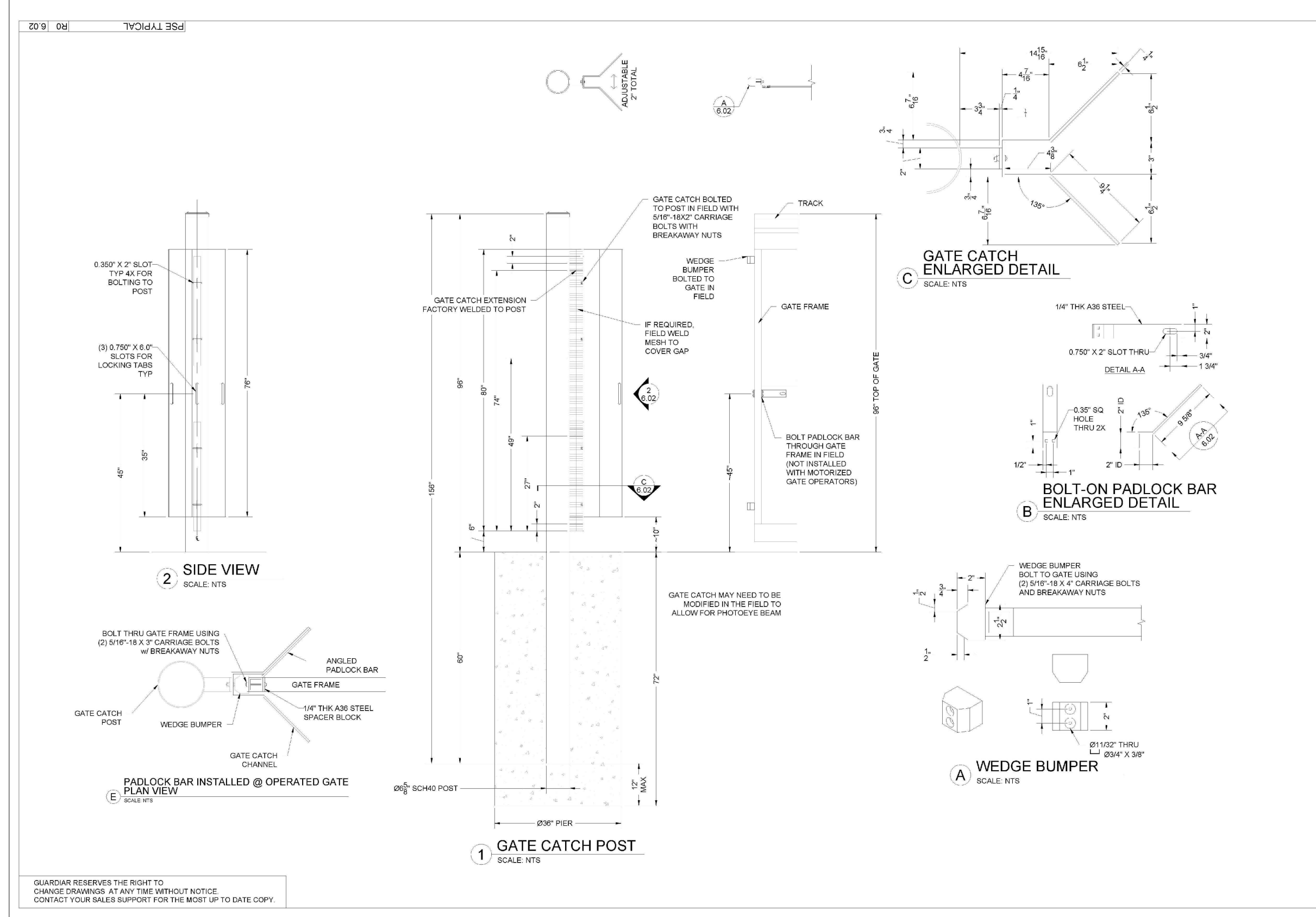

PROJECT NO.	202202.06
DATE	07/11/24
PROJECT NAME	PSE TYPICAL
DATE	07/11/24
PROJECT LOCATION	1814 BROADWAY ST., BELLINGHAM, WA 98225
DATE	07/11/24
PROJECT TYPE	PERMITTING
DATE	07/11/24
PROJECT NO.	202202.06
DATE	07/11/24
PROJECT NAME	PSE TYPICAL
DATE	07/11/24
PROJECT LOCATION	1814 BROADWAY ST., BELLINGHAM, WA 98225
DATE	07/11/24
PROJECT TYPE	PERMITTING
DATE	07/11/24
PROJECT NO.	202202.06
DATE	07/11/24
PROJECT NAME	PSE TYPICAL
DATE	07/11/24
PROJECT LOCATION	1814 BROADWAY ST., BELLINGHAM, WA 98225
DATE	07/11/24
PROJECT TYPE	PERMITTING
DATE	07/11/24
PROJECT NO.	202202.06
DATE	07/11/24
PROJECT NAME	PSE TYPICAL
DATE	07/11/24
PROJECT LOCATION	1814 BROADWAY ST., BELLINGHAM, WA 98225
DATE	07/11/24
PROJECT TYPE	PERMITTING
DATE	07/11/24
PROJECT NO.	202202.06
DATE	07/11/24
PROJECT NAME	PSE TYPICAL
DATE	07/11/24
PROJECT LOCATION	1814 BROADWAY ST., BELLINGHAM, WA 98225
DATE	07/11/24
PROJECT TYPE	PERMITTING
DATE	07/11/24

1 CANTELEVER GATE DETAIL  
NTS - CONTACT MANUFACTURER FOR SCALED DWGS.

100% CD Set		
REV	ISSUED FOR	DATE
1	PERMIT COMMENTS	05.29.24
2	FENCE UPDATES	07.11.24
3	FENCE UPDATES	11.19.24

SCALE: NTS

PSE - OPERATIONAL TRAINING CENTER

DETAIL SHEET

PROJECT NO:	202202.06
DRAWN BY:	SPW
CHECKED BY:	PLA
DATE ISSUED:	07/11/24

L2.5