

MULTICARE CTU
102 15TH AVE SE
PUYALLUP, WA
PARCEL# 7790000566



City of Puyallup
Development & Permitting Services
ISSUED PERMIT

Building	Planning
Engineering	Public Works
Fire	Traffic

LOUIS LYNN
FIRE ALARM SYSTEMS III
SPECIAL HAZARDS III
WATER BASED SYSTEMS LAYOUT II
CERT # 119584
EXP 6/1/25



KEY PLAN

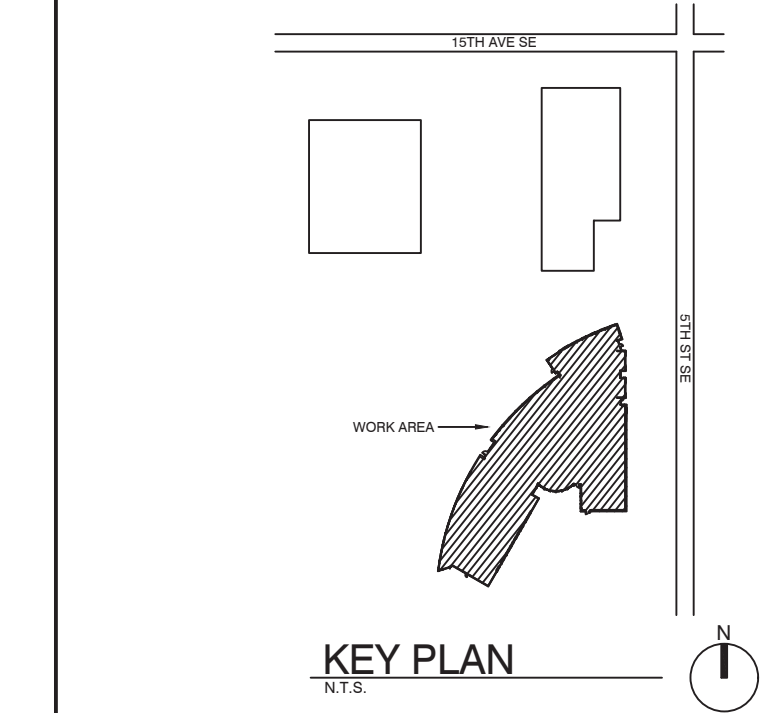

ISSUE LOG:

DATE	INT	DESCRIPTION

CONSTRUCTION SET

DESIGNER:	SCOTT JERKE
ISSUE DATE:	11/18/24
PROJECT #:	FA24129
SYSTEM:	FIRE ALARM

SHEET:
DEVICE LOCATION
VIEWS & RISER
DIAGRAM

FA101

A **DEVICE LOCATIONS - FIRST FLOOR PLAN**
SCALE: 3/32" = 1'-0"

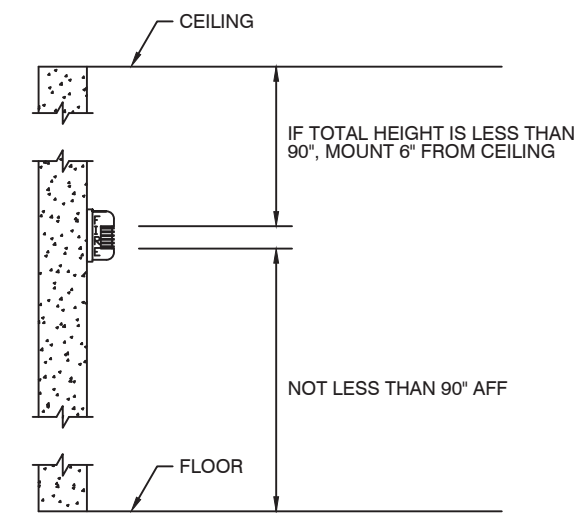

NFPA 72 2013, 18.4.8.1
WALL MOUNTED APPLIANCES SHALL HAVE THEIR TOPS ABOVE THE FINISHED FLOOR AT HEIGHTS OF NOT LESS THAN 90" AND BELOW THE FINISHED CEILING AT DISTANCES OF NOT LESS THAN 6".

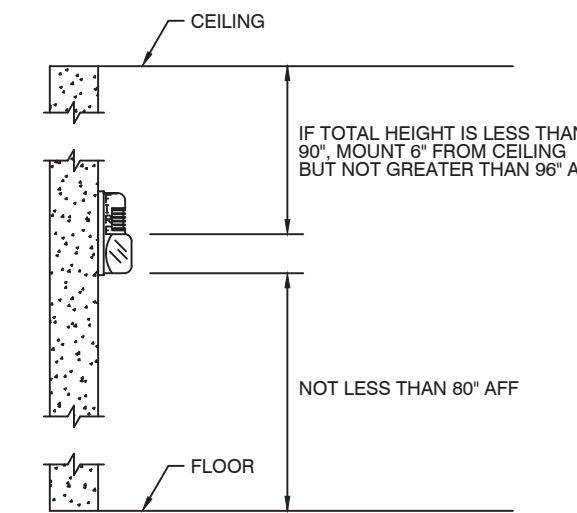

NFPA 72 2013, 18.5.5.1
WALL MOUNTED APPLIANCES SHALL BE MOUNTED SUCH THAT THE ENTIRE LENS IS NOT LESS THAN 96" AND NOT GREATER THAN 96" ABOVE THE FINISHED FLOOR.

A FIRE ALARM - HORN MOUNTING

B FIRE ALARM - STROBE MOUNTING

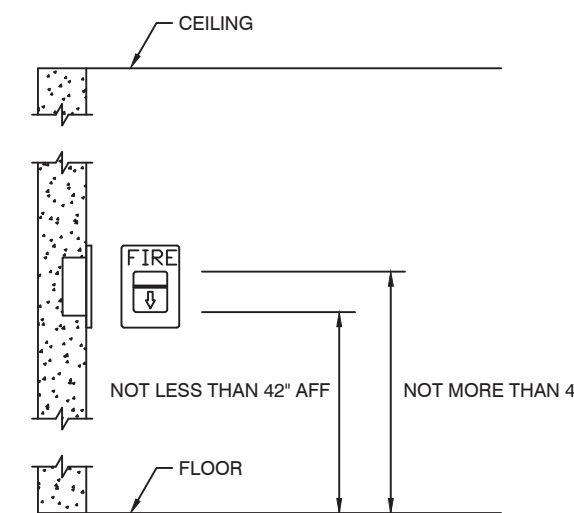

NFPA 72 2013, 17.14.5
THE OPERABLE PART OF A MANUALLY ACTIVATED ALARM INITIATING DEVICE SHALL BE NOT LESS THAN 42" AND NOT MORE THAN 48" FROM THE FINISHED FLOOR.

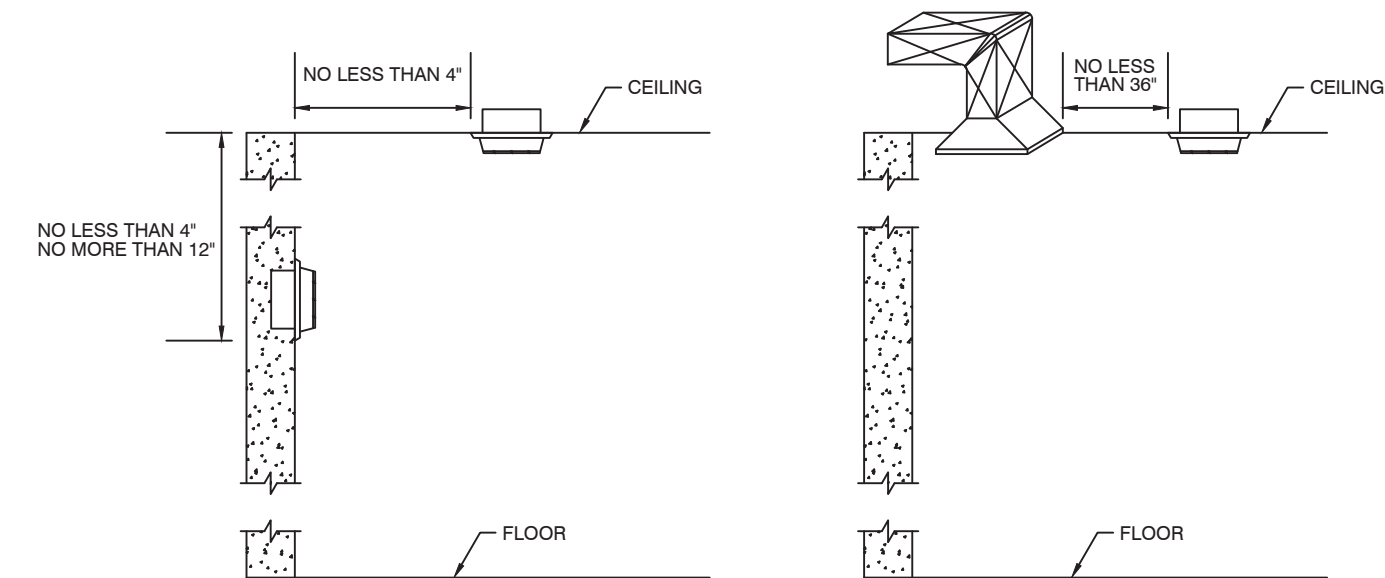

NFPA 72 2013, 17.6.3.1.3.1
DETECTORS SHALL BE LOCATED ON THE CEILING NOT LESS THAN 4" FROM THE SIDEWALL OR ON THE SIDEWALLS BETWEEN 4" AND 12" FROM THE CEILING.

NFPA 72 2013, A.17.7.4.1
DETECTORS SHALL NOT BE LOCATED IN DIRECT AIRFLOW OR CLOSER THAN 36" FROM AN AIR SUPPLY, DIFFUSER OR RETURN AIR OPENING.

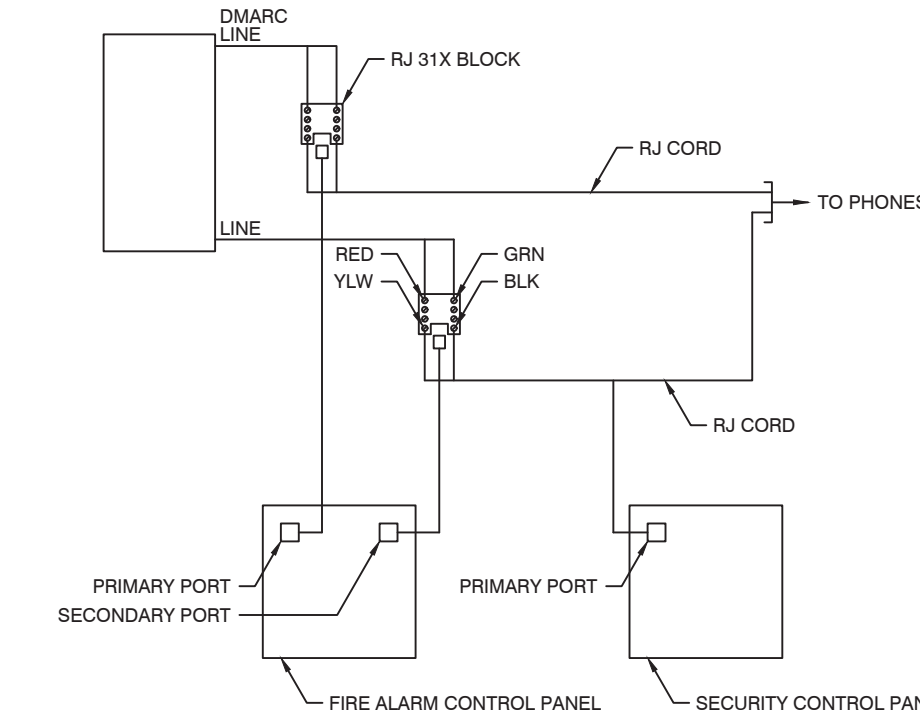

C FIRE ALARM - PULL STATION MOUNTING

D FIRE ALARM - SMOKE & HEAT MOUNTING

E FIRE ALARM - PHONE CONNECTION

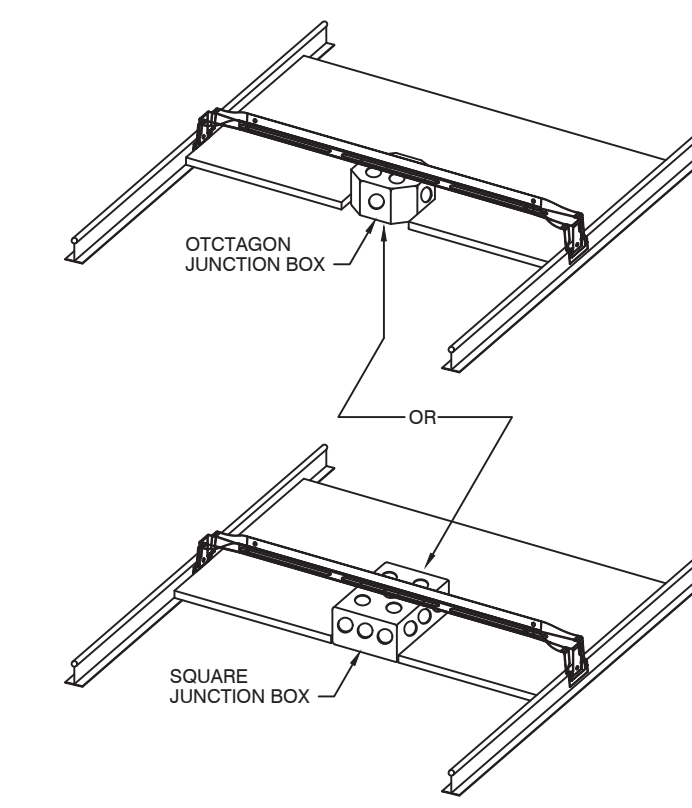
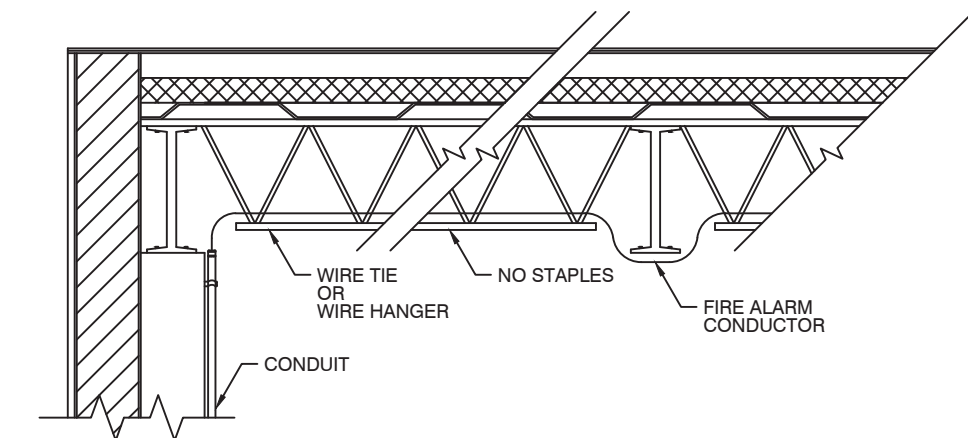
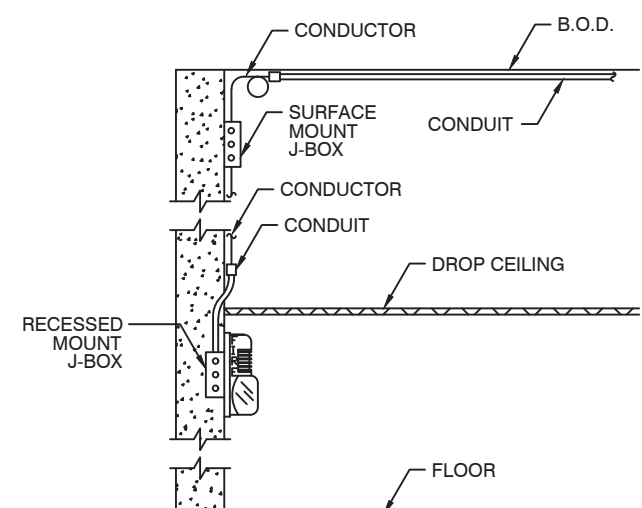

F FIRE ALARM - CONDUIT WALL & CEILING

G FIRE ALARM - CEILING TO WALL TRANSITION AND OPEN WIRING

H FIRE ALARM - DROP CEILING & J BOX

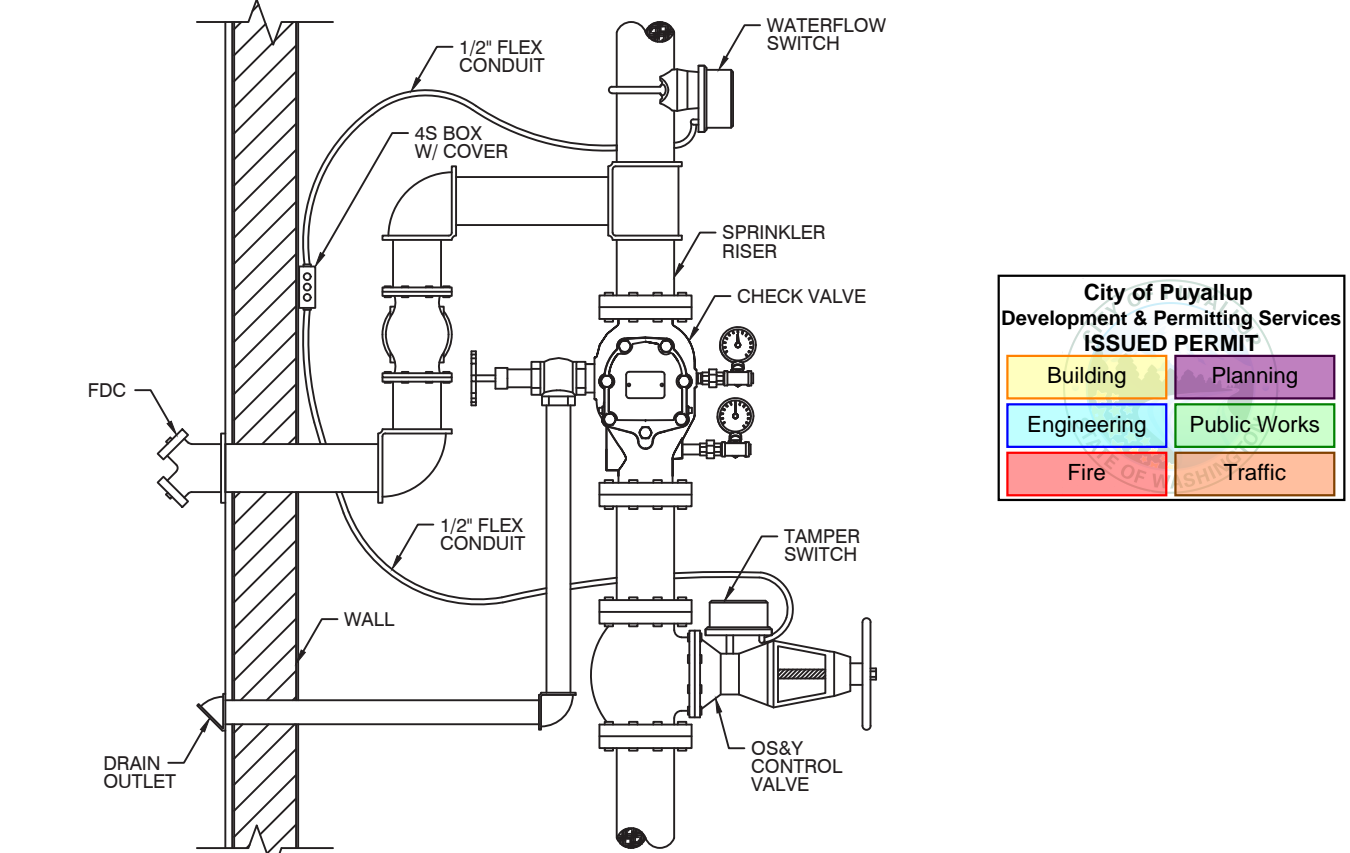
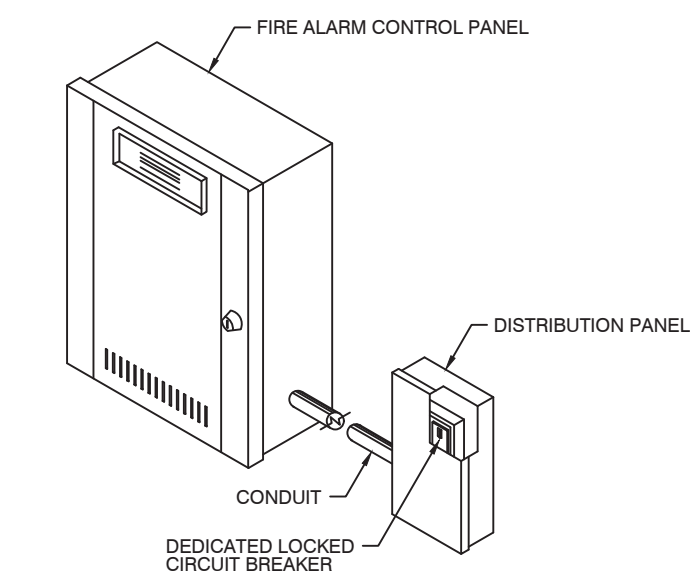
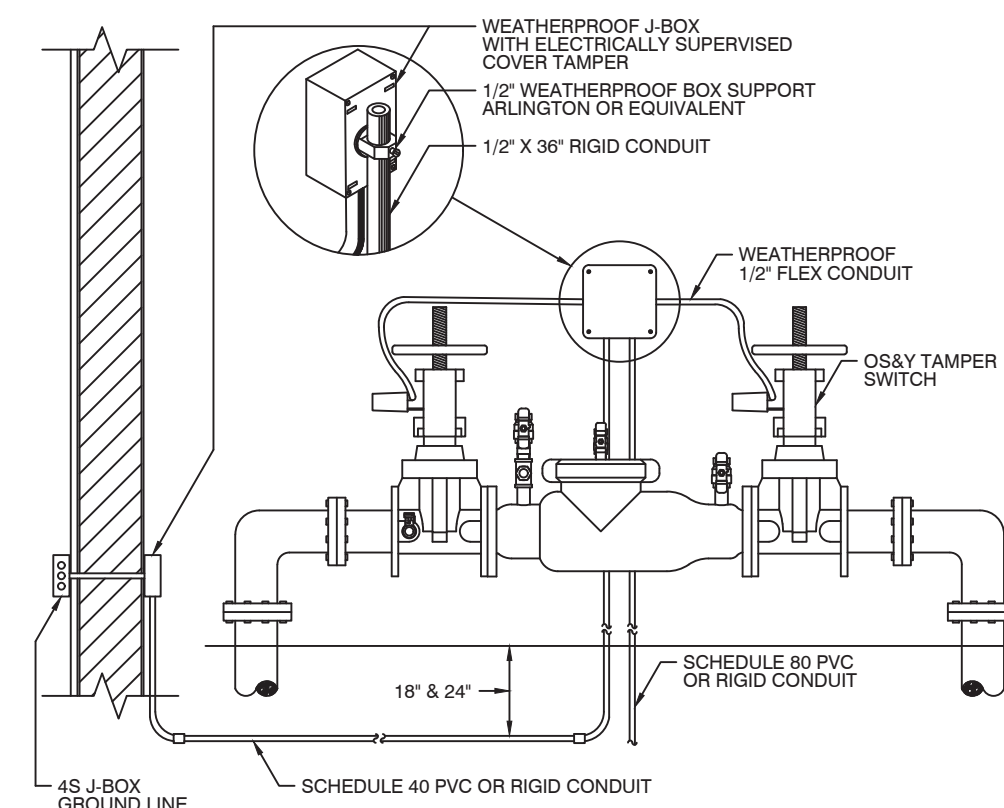

I FIRE ALARM - DCVA TAMPER SWITCHES

J FIRE ALARM - POWER DISCONNECT

K FIRE ALARM - OS&Y TAMPER GATE VALVE

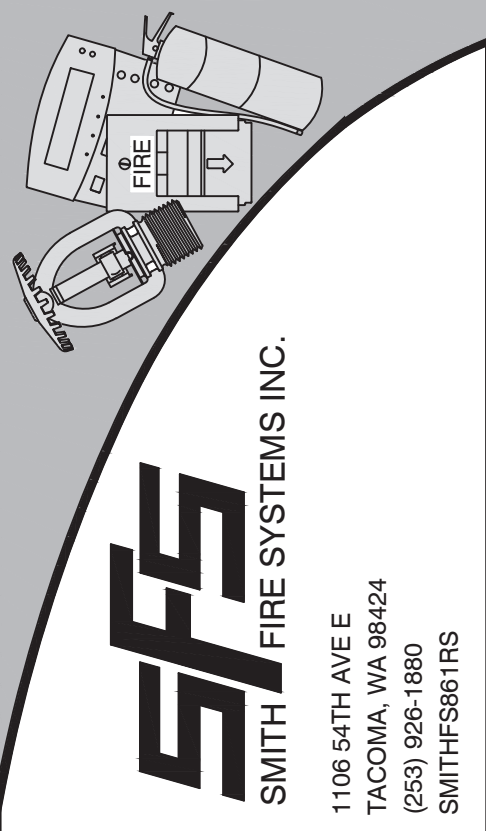

MULTICARE CTU
102 15TH AVE SE
PUYALLUP, WA
PARCEL# 7790000566

ISSUE LOG:	DATE	INT	DESCRIPTION

CONSTRUCTION SET
DESIGNER: SCOTT JERKE
ISSUE DATE: 11/18/24
PROJECT #: FA24129
SYSTEM:

FIRE ALARM

SHEET:
PRODUCT TYPICALS
FA601

