



PRCTI20250486

Section 2

City of Puyallup Development & Permitting Services ISSUED PERMIT	
Building	Planning
Engineering	Public Works
Fire	Traffic

Generator Specification Sheets

Specification Sheet



Diesel ✓ Generator Set QSL9-G7 Series Engine

250 kW - 300 kW Standby



Description

Cummins® commercial generator sets are fully integrated power generation systems providing optimum performance, reliability and versatility for stationary Standby and Prime Power applications.

Features

Cummins heavy-duty engine - Rugged 4-cycle, industrial diesel delivers reliable power, low emissions and fast response to load changes.

Alternator - Several alternator sizes offer selectable motor starting capability with low reactance 2/3 pitch windings, low waveform distortion with non-linear loads and fault clearing short-circuit capability.

Control system - The PowerCommand® 2.3 electronic control is standard equipment and provides total generator set system integration including automatic remote starting/stopping, precise frequency and voltage regulation, alarm and status message display, output metering, auto-shutdown at fault detection and NFPA 110 Level 1 compliance. The PowerCommand® 3.3 control is also available as an option.

Cooling system - Standard cooling package provides reliable running at the rated power level.

Enclosures - Optional weather protective and sound attenuated enclosures are available.

Fuel tanks - Dual wall sub-base fuel tanks are also available.

NFPA - The genset accepts full rated load in a single step in accordance with NFPA 110 for Level 1 systems.

Warranty and service - Backed by a comprehensive warranty and worldwide distributor network.

Model	Standby rating		Prime rating		Continuous rating		Data sheets	
	60 Hz kW (kVA)	50 Hz kW (kVA)	60 Hz kW (kVA)	50 Hz kW (kVA)	60 Hz kW (kVA)	50 Hz kW (kVA)	60 Hz	50 Hz
DQDAA	250 (313)		225 (281)				D-3442	
DQDAB	275 (344)		250 (313)				D-3443	
DQDAC	300 (375)		270 (338)				D-3444	

Generator Set Specifications

Governor regulation class	ISO 8528 Part 1 Class G3
Voltage regulation, no load to full load	± 0.5%
Random voltage variation	± 0.5%
Frequency regulation	Isochronous
Random frequency variation	± 0.5%
Radio frequency emissions compliance	IEC 801.2 through IEC 801.5; MIL-STD-461C, Part 9

Engine Specifications

Bore	114.0 mm (4.49 in)
Stroke	145 mm (5.69 in)
Displacement	8.9 L (543 in ³)
Configuration	Cast iron, in-line 6 cylinder
Battery capacity	750 amps minimum at ambient temperature of -18 °C (-0.4 °F) and above
Battery charging alternator	70 amps
Starting voltage ✓	24 volt, negative ground ✓
Fuel system	Direct injection: number 2 diesel fuel, fuel filter, automatic electric fuel shutoff
Fuel filter	Dual element with water separator
Air cleaner type	Normal duty
Lube oil filter type(s)	Single spin-on, combination full flow and bypass filters
Standard cooling system	High ambient radiator

Alternator Specifications

Design	Brushless, 4 pole, drip proof revolving field
Stator	2/3 pitch
Rotor	Single bearing, flexible discs
Insulation system	Class H
Standard temperature rise	125 °C Standby, 105 °C Prime
Exciter type	Permanent Magnet Generator (PMG)
Phase rotation	A (U), B (V), C (W)
Alternator cooling	Direct drive centrifugal blower
AC waveform Total Harmonic Distortion (THDV)	< 5% no load to full linear load, < 3% for any single harmonic
Telephone Influence Factor (TIF)	< 50 per NEMA MG1-22.43
Telephone Harmonic Factor (THF)	< 3

Available Voltages

60 Hz 3-phase		50 Hz 3-phase	
Reconnectable	Non-Reconnectable	Reconnectable	Non-Reconnectable
<ul style="list-style-type: none"> • 110/90 • 139/240 • 240/416 	<ul style="list-style-type: none"> • 120/208 • 120/240 • 254/440 	<ul style="list-style-type: none"> • 277/480 • 347/600 	

Note: Consult factory for other voltages.

Provide 480Y/277V

Generator Set Options and Accessories

Engine

- 120/240 V 1500 W coolant heater
- 120/240 V 150 W lube oil heater
- Heavy duty air cleaner
- Engine oil temperature

Control panel

- 120/240 V 100 W control anti-condensation heater
- Exhaust pyrometer
- Ground fault indication
- Remote fault signal package
- Run relay package
- Paralleling configuration

Alternator

- 105 °C rise
- 125 °C rise
- 120/240 V 100 W anti-condensation heater
- PMG excitation
- Single phase

Exhaust system

- Genset mounted muffler
- Heavy duty exhaust elbow
- Slip on exhaust connection
- NPT exhaust connection

Fuel system

- 1022 L (270 gal) sub-base tank
- 1136 L (300 gal) sub-base tank
- 1514 L (400 gal) sub-base tank
- 1893 L (500 gal) sub-base tank
- 2271 L (600 gal) sub-base tank
- 2498 L (660 gal) sub-base tank
- 2725 L (720 gal) sub-base tank
- 5565 L (1470 gal) sub-base tank

Generator set

- AC entrance box
- Battery
- Battery charger
- Export box packaging
- UL 2200 Listed
- Main line circuit breaker
- PowerCommand network
- Communications Module (NCM)
- Remote annunciator panel
- Spring isolators
- Enclosure: aluminum, steel, weather protective or sound attenuated
- 2 year Standby power warranty
- 2 year Prime power warranty
- 5 year Basic power warranty
- 10 year major components warranty

Note: Some options may not be available on all models - consult factory for availability.

Control system 2.3



The PowerCommand 2.3 control system - An integrated generator set control system providing voltage regulation, engine protection, generator protection, operator interface and isochronous governing (optional).

Control – Provides battery monitoring and testing features and *smart-starting control system*.

InPower™ – PC-based service tool available for detailed diagnostics.

PCCNet RS485 – Network interface (standard) to devices such as remote annunciator for NFPA 110 applications.

Control boards – Potted for environmental protection.

Ambient operation – Suitable for operation in ambient temperatures from -40 °C to +70 °C and altitudes to 13,000 feet (5000 meters). Prototype tested - UL, CSA and CE compliant.

AC protection

- AmpSentry protective relay
- Over current warning and shutdown
- Over and under voltage shutdown
- Over and under frequency shutdown
- Over excitation (loss of sensing) fault
- Field overload
- Overload warning
- Reverse kW shutdown
- Reverse Var shutdown
- Short circuit protection

Engine protection

- Overspeed shutdown
- Low oil pressure warning and shutdown
- High coolant temperature warning and shutdown
- Low coolant level warning or shutdown
- Low coolant temperature warning
- High, low and weak battery voltage warning
- Fail to start (overcrank) shutdown
- Fail to crank shutdown
- Redundant start disconnect
- Cranking lockout
- Sensor failure indication
- Low fuel level warning or shutdown
- Fuel-in-rupture-basin warning or shutdown

Operator/display panel

- Manual off switch
- 128 x 128 Alpha-numeric display with push button access for viewing engine and alternator data and providing setup, controls and adjustments (English or international symbols)
- LED lamps indicating genset running, not in auto, common warning, common shutdown, manual run mode and remote start
- Suitable for operation in ambient temperatures from -20 °C to +70 °C

Alternator data

- Line-to-Neutral AC volts
- Line-to-Line AC volts
- 3-phase AC current
- Frequency
- kVA, kW, power factor

Engine data

- DC voltage
- Lube oil pressure
- Coolant temperature

Control functions

- Time delay start and cool down
- Glow plug control (some models)
- Cycle cranking
- PCCNet interface
- (4) Configurable inputs
- (4) Configurable outputs
- Remote emergency stop
- Battle short mode
- Load shed
- Real time clock with exerciser
- Derate

Digital governing (optional)

- Integrated digital electronic isochronous governor
- Temperature dynamic governing

Digital voltage regulation

- Integrated digital electronic voltage regulator
- 3-phase Line-to-Line sensing
- Configurable torque matching
- Fault current regulation under single or three phase fault conditions

Other data

- Genset model data
- Start attempts, starts, running hours
- Fault history
- RS485 Modbus® interface
- Data logging and fault simulation (requires InPower service tool)
- Total kilowatt hours
- Load profile

Options

- Auxiliary output relays (2)
- 120/240 V, 100 W anti-condensation heater
- Remote annunciator with (3) configurable inputs and (4) configurable outputs
- PMG alternator excitation
- PowerCommand for Windows® remote monitoring software (direct connect)
- AC output analogue meters
- PowerCommand 2.3 and 3.3 control with AmpSentry protection

For further detail on PC 2.3 see document S-1569.

For further detail on PC 3.3 see document S-1570.

PowerCommand 3.3 Control System



An integrated microprocessor based generator set control system providing voltage regulation, engine protection, alternator protection, operator interface and isochronous governing. Refer to document S-1570 for more detailed information on the control.

AmpSentry – Includes integral AmpSentry protection, which provides a full range of alternator protection functions that are matched to the alternator provided.

Power management – Control function provides battery monitoring and testing features and smart starting control system.

Advanced control methodology – Three phase sensing, full wave rectified voltage regulation, with a PWM output for stable operation with all load types.

Communications interface – Control comes standard with PCCNet and Modbus® interface.

Regulation compliant – Prototype tested: UL, CSA and CE compliant.

Service - InPower™ PC-based service tool available for detailed diagnostics, setup, data logging and fault simulation.

Easily upgradeable – PowerCommand controls are designed with common control interfaces.

Reliable design – The control system is designed for reliable operation in harsh environment.

Multi-language support

Operator panel features

Operator/display functions

- Displays paralleling breaker status
- Provides direct control of the paralleling breaker
- 320 x 240 pixels graphic LED backlight LCD
- Auto, manual, start, stop, fault reset and lamp test/panel lamp switches
- Alpha-numeric display with pushbuttons
- LED lamps indicating generator set running, remote start, not in auto, common shutdown, common warning, manual run mode, auto mode and stop

Paralleling control functions

- First Start Sensor System selects first generator set to close to bus
- Phase Lock Loop Synchronizer with voltage matching
- Sync check relay
- Isochronous kW and kVar load sharing
- Load govern control for utility paralleling
- Extended Paralleling (Base Load/Peak Shave) Mode
- Digital power transfer control, for use with a breaker pair to provide open transition, closed transition, ramping closed transition, peaking and base load functions,
- Alternator data
- Line-to-Neutral and Line-to-Line AC volts
- 3-phase AC current
- Frequency
- kW, kVar, power factor kVA (three phase and total)

- Engine data
- DC voltage
- Engine speed
- Lube oil pressure and temperature
- Coolant temperature
- Comprehensive FAE data (where applicable)
- Other data
- Genset model data
- Start attempts, starts, running hours, kW hours
- Load profile (operating hours at % load in 5% increments)
- Fault history
- Data logging and fault simulation (requires InPower)

Standard control functions

Digital governing

- Integrated digital electronic isochronous governor
- Temperature dynamic governing

Digital voltage regulation

- Integrated digital electronic voltage regulator
- 3-phase, 4-wire Line-to-Line sensing
- Configurable torque matching

AmpSentry AC protection

- AmpSentry protective relay
- Over current and short circuit shutdown
- Over current warning
- Single and three phase fault regulation
- Over and under voltage shutdown
- Over and under frequency shutdown
- Overload warning with alarm contact
- Reverse power and reverse Var shutdown
- Field overload shutdown

Engine protection

- Battery voltage monitoring, protection and testing
- Overspeed shutdown
- Low oil pressure warning and shutdown
- High coolant temperature warning and shutdown
- Low coolant level warning or shutdown
- Low coolant temperature warning
- Fail to start (overcrank) shutdown
- Fail to crank shutdown
- Cranking lockout
- Sensor failure indication
- Low fuel level warning or shutdown
- Fuel-in-rupture-basin warning or shutdown
- Full authority electronic engine protection

Control functions

- Time delay start and cool down
- Real time clock for fault and event time stamping
- Exerciser clock and time of day start/stop
- Data logging
- Cycle cranking
- Load shed
- Configurable inputs and outputs (4)
- Remote emergency stop

Options

- Auxiliary output relays (2)

Ratings Definitions

Emergency Standby Power (ESP):

Applicable for supplying power to varying electrical load for the duration of power interruption of a reliable utility source. Emergency Standby Power (ESP) is in accordance with ISO 8528. Fuel Stop power in accordance with ISO 3046, AS 2789, DIN 6271 and BS 5514.

Limited-Time Running Power (LTP):

Applicable for supplying power to a constant electrical load for limited hours. Limited Time Running Power (LTP) is in accordance with ISO 8528.

Prime Power (PRP):

Applicable for supplying power to varying electrical load for unlimited hours. Prime Power (PRP) is in accordance with ISO 8528. Ten percent overload capability is available in accordance with ISO 3046, AS 2789, DIN 6271 and BS 5514.

Base Load (Continuous) Power (COP):

Applicable for supplying power continuously to a constant electrical load for unlimited hours. Continuous Power (COP) in accordance with ISO 8528, ISO 3046, AS 2789, DIN 6271 and BS 5514.

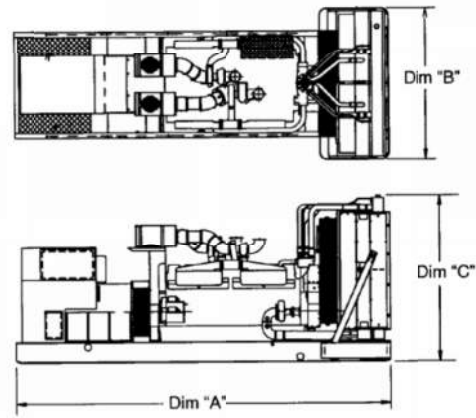

This outline drawing is for reference only. See respective model data sheet for specific model outline drawing number.

Do not use for installation design

Dimensions and weights with standard cooling system

Model	Dim "A" mm (in.)	Dim "B" mm (in.)	Dim "C" mm (in.)	Estimated set weight* dry kg (lbs)	Estimated set weight* wet kg (lbs)
DQDAA	3023 (119.0)	1270 (50.0)	1617 (64.0)	2184 (4814)	2234 (4926)
DQDAB	3023 (119.0)	1270 (50.0)	1617 (64.0)	2184 (4814)	2234 (4926)
DQDAC					2370 (5225)

Refer to drawings for specific weights and dimensions

Dimensions at L228-2 and/or





ature codes

Model	Dim A mm (in.)	Dim B mm (in.)	Dim C mm (in.)	Estimated set weight* dry kg (lbs)	Estimated set weight* wet kg (lbs)
DQDAA	3023 (119.0)	1270 (50.0)	1676 (66.0)	2184 (4814)	2234 (4926)
DQDAB	3023 (119.0)	1270 (50.0)	1676 (66.0)	2184 (4814)	2234 (4926)
DQDAC	3023 (119.0)	1270 (50.0)	1676 (66.0)	2319 (5113)	2370 (5225)

*Note: Weights represent a set with standard features. See outline drawings for weights of other configurations

Codes and Standards

Codes or standards compliance may not be available with all model configurations – consult factory for availability.

	<p>This generator set is designed in facilities certified to ISO 9001 and manufactured in facilities certified to ISO 9001 or ISO 9002.</p>		<p>The PowerCommand control is Listed to UL 508 - Category NITW7 for U.S. and Canadian usage.</p>
	<p>The Prototype Test Support (PTS) program verifies the performance integrity of the generator set design. Cummins products bearing the PTS symbol meet the prototype test requirements of NFPA 110 for Level 1 systems.</p>	<p>U.S. EPA</p>	<p>Engine certified to Stationary Emergency U.S. EPA New Source Performance Standards, 40 CFR 60 subpart IIII Tier 3 exhaust emission levels. U.S. applications must be applied per this EPA regulation.</p>
	<p>All low voltage models are CSA certified to product class 4215-01.</p>	<p>International Building Code</p>	<p>The generator set package is available certified for seismic application in accordance with the following International Building Code: IBC2000, IBC2003, IBC2006, IBC2009 and IBC2012.</p>

Warning: Back feed to a utility system can cause electrocution and/or property damage. Do not connect to any building's electrical system except through an approved device or after building main switch is open.

For more information contact your local Cummins distributor or visit power.cummins.com

Our energy working for you.™



Generator set data sheet



Model: **DQDAA**
Frequency: **60 Hz**
Fuel type: **Diesel**
kW rating: **250 Standby**
225 Prime
Emissions level: **EPA NSPS Stationary Emergency Tier 3**

Exhaust emission data sheet:	EDS-1073
Exhaust emission compliance sheet:	EPA-1101
Sound performance data sheet:	MSP-1026
Cooling performance data sheet:	MCP-163
Prototype test summary data sheet:	PTS-164
Standard set-mounted radiator cooling outline:	A048R355
Optional set-mounted radiator cooling outline with seismic feature codes L228-2 (IBC) or L225-2 (OSHPD):	A041F591

Fuel consumption	Standby				Prime				Continuous
	kW (kVA)				kW (kVA)				kW (kVA)
Ratings	250 (313)				225 (281)				
Load	1/4	1/2	3/4	Full	1/4	1/2	3/4	Full	Full
US gph	6.0	10.5	15.1	19.6	5.5	9.5	13.6	17.7	
L/hr	22.5	39.7	56.9	74.2	20.7	36.1	51.5	67.0	

Engine	Standby rating	Prime rating	Continuous rating
Engine manufacturer	Cummins Inc.		
Engine model	QSL9-G7		
Configuration	Cast iron, in-line 6 cylinder		
Aspiration	Turbocharged and after-cooled		
Gross engine power output, kW _m (bhp)	346 (464)	312 (419)	
BMEP at set rated load, kPa (psi)	2606 (378)	2351 (341)	
Bore, mm (in.)	114.0 (4.49)		
Stroke, mm (in.)	145 (5.69)		
Rated speed, rpm	1800		
Piston speed, m/s (ft/min)	8.7 (1707.0)		
Compression ratio	16.1:1		
Lube oil capacity, L (qt)	30.0 (31.7)		
Overspeed limit, rpm	2070 ± 50		
Regenerative power, kW	35.00		

Fuel flow	
Maximum fuel flow, L/hr (US gph)	138.1 (36.5)
Maximum fuel inlet restriction, mm Hg (in Hg)	152.4 (6.0)
Maximum return restriction, mm Hg (in Hg)	254.0 (10.0)

Air	Standby rating	Prime rating	Continuous rating
Combustion air, m ³ /min (scfm)	22.3 (787)	20.8 (733)	
Maximum air cleaner restriction, kPa (in H ₂ O)	6.2 (25.0)		
Alternator cooling air, m ³ /min (cfm)	59.4 (2100.0)		

Exhaust

Exhaust flow at set rated load, m ³ /min (cfm)	54.6 (1927)	50.6 (1796)	
Exhaust temperature, °C (°F)	525 (977)	495 (923)	
Maximum back pressure, kPa (in H ₂ O)	10.2 (41.0)		

Standard set-mounted radiator cooling (non-seismic)

Ambient design, °C (°F)	50 (122)		
Fan load, kW _m (HP)	26.09 (35)		
Coolant capacity (with radiator), L (US gal)	34.29 (9.06)		
Cooling system air flow, m ³ /min (scfm)	427.58 (15190)		
Total heat rejection, MJ/min (Btu/min)	8.93 (8467.0)	8.55 (8104.0)	
Maximum cooling air flow static restriction, kPa (in H ₂ O)	0.12 (0.5)		

Optional set-mounted radiator cooling (with seismic feature codes L228-2 (IBC) and/or L225-2 (OSHPD))

Ambient design, °C (°F)	50 (122)		
Fan load, kW _m (HP)	27.8 (37.2)		
Coolant capacity (with radiator), L (US gal)	30.3 (8.0)		
Cooling system air flow, m ³ /min (scfm)	568.1 (20075.0)		
Total heat rejection, MJ/min (Btu/min)	8.93 (8467.0)	8.55 (8104.0)	
Maximum cooling air flow static restriction, kPa (in H ₂ O)	0.12 (0.5)		

Weights²

Refer to drawings for specific weights and dimensions

Notes:

¹ For non-standard remote installations contact your local Cummins representative.

² Weights represent a set with standard features. See outline drawing for weights of other configurations.

Derating factors

Standby	Engine power available up to 1494 m (4900 ft) at ambient temperature up to 40 °C (104 °F). Above these elevations, derate at 7% per 400m (1312 ft). Above 40 °C (104 °F) derate 5.5% per 10 °C (18 °F). Derates must be combined when both altitude of 1494 m (4900 ft) and temperature of 40 °C (104 °F) are exceeded.
Prime	Engine power available up to 1452 m (4764 ft) at ambient temperature up to 40 °C (104 °F). Above these elevations, derate at 7% per 400m (1312 ft). Above 40 °C (104 °F) derate 5.5% per 10 °C (18 °F). Derates must be combined when both altitude of 1452 m (4764 ft) and temperature of 40 °C (104 °F) are exceeded.
Continuous	

Ratings definitions

Emergency Standby Power (ESP):	Limited-Time Running Power (LTP):	Prime Power (PRP):	Base Load (Continuous) Power (COP):
Applicable for supplying power to varying electrical load for the duration of power interruption of a reliable utility source. Emergency Standby Power (ESP) is in accordance with ISO 8528. Fuel stop power in accordance with ISO 3046, AS 2789, DIN 6271 and BS 5514.	Applicable for supplying power to a constant electrical load for limited hours. Limited-Time Running Power (LTP) is in accordance with ISO 8528.	Applicable for supplying power to varying electrical load for unlimited hours. Prime Power (PRP) is in accordance with ISO 8528. Ten percent overload capability is available in accordance with ISO 3046, AS 2789, DIN 6271 and BS 5514.	Applicable for supplying power continuously to a constant electrical load for unlimited hours. Continuous Power (COP) is in accordance with ISO 8528, ISO 3046, AS 2789, DIN 6271 and BS 5514.

Alternator data

Three phase table ¹	80 °C	80 °C	80 °C	80 °C	105 °C	105 °C	105 °C	125 °C	125 °C	125 °C	125 °C	125 °C
Feature code	B260	B257	B251	B302	B259	B256	B301	B258	B252	B246	B247	B300
Alternator data sheet number	342	341	341	341	341	341	340	341	340	340	340	340
Voltage ranges	110/190 thru 139/240 220/380 thru 277/480	120/208 thru 139/240 240/416 thru 277/480	277/480	347/600	110/190 thru 139/240 220/380 thru 277/480	120/208 thru 139/240 240/416 thru 277/480	347/600	110/190 thru 139/240 220/380 thru 277/480	120/208 thru 139/240 240/416 thru 277/480	277/480	277/480	347/600
Surge kW	322	322	322	322	322	322	322	322	322	322	322	322
Motor starting kVA (at 90% sustained voltage)	Shunt											
	PMG	1372	1210	1210	1210	1210	1210	1028	1210	1028	1028	1028
Full load current - amps at Standby rating	120/208 867	127/220 820	139/240 752	220/380 475	240/416 434	254/440 410	277/480 376	347/600 301				

Note:

¹ Single phase power can be taken from a three phase generator set at up to 2/3 set rated 3-phase kW at 1.0 power factor. Also see Note 3 below

480Y/277V

Formulas for calculating full load currents:

Three phase output

$$\frac{\text{kW} \times 1000}{\text{Voltage} \times 1.73 \times 0.8}$$

Single phase output

$$\frac{\text{kW} \times \text{SinglePhaseFactor} \times 1000}{\text{Voltage}}$$

Warning: Back feed to a utility system can cause electrocution and/or property damage. Do not connect to any building's electrical system except through an approved device or after building main switch is open.

For more information contact your local Cummins distributor
or visit power.cummins.com

Our energy working for you.™



Specification Sheet



PowerCommand® 2.3 Control System



Control System Description

The PowerCommand control system is a microprocessor-based generator set monitoring, metering and control system designed to meet the demands of today's engine driven generator sets. The integration of all control functions into a single control system provides enhanced reliability and performance, compared to conventional generator set control systems. These control systems have been designed and tested to meet the harsh environment in which gensets are typically applied.

Features

- 320 x 240 pixels graphic LED backlight LCD.
- Multiple language support.
- AmpSentry™ protective relay - true alternator overcurrent protection.
- Real time clock for fault and event time stamping.
- Exerciser clock and time of day start/stop.
- Digital voltage regulation. Three phase full wave FET type regulator compatible with either shunt or PMG systems.
- Generator set monitoring and protection.
- 12 and 24 VDC battery operation.
- Modbus® interface for interconnecting to customer equipment.
- Warranty and service. Backed by a comprehensive warranty and worldwide distributor service network.
- Certifications - suitable for use on generator sets that are designed, manufactured, tested and certified to relevant UL, NFPA, ISO, IEC, Mil Std., CE, UKCA and CSA standards.

PowerCommand Digital Genset Control PCC 2300



Description

The PowerCommand generator set control is suitable for use on a wide range of generator sets in non-paralleling applications. The PowerCommand control is compatible with shunt or PMG excitation style. It is suitable for use with reconnectable or non-reconnectable generators, and it can be configured for any frequency, voltage and power connection from 120-600 VAC Line-to-Line.

Power for this control system is derived from the generator set starting batteries. The control functions over a voltage range from 8 VDC to 30 VDC.

Features

- 12 and 24 VDC battery operation.
- Digital voltage regulation - Three phase full wave FET type regulator compatible with either shunt or PMG systems. Sensing is three phase.
- Full authority engine communications (where applicable) - Provides communication and control with the Engine
- due to thermal Control Module (ECM).
- AmpSentry™ protection provides industry-leading alternator overcurrent protection:
 - Time-based generator protection applicable to both line-to-line and line-to-neutral, that can detect an unbalanced fault condition and swiftly react appropriately. Balanced faults can also be detected by AmpSentry and appropriate acted upon.
- Reduces the risk of Arc Flash overload or electrical faults by inverse time protection
- Common harnessing - with higher feature Cummins controls. Allows for easy field upgrades.
- Generator set monitoring - Monitors status of all critical engine and alternator functions.
- Digital genset metering (AC and DC).
- Genset battery monitoring system to sense and warn against a weak battery condition.
- Configurable for single or three phase AC metering.
- Engine starting - Includes relay drivers for starter, Fuel Shut Off (FSO), glow plug/spark ignition power and switch B+ applications.
- Generator set protection – Protects engine and alternator.
- Real time clock for fault and event time stamping.
- Exerciser clock and time of day start/stop.
- Advanced serviceability - using InPower™, a PC-based software service tool.

- Environmental protection - The control system is designed for reliable operation in harsh environments. The main control board is a fully encapsulated module that is protected from the elements.
- Modbus interface for interconnecting to customer equipment.
- Configurable inputs and outputs - Four discrete inputs and four dry contact relay outputs.
- Warranty and service - Backed by a comprehensive warranty and worldwide distributor service network.
- Certifications - Suitable for use on generator sets that are designed, manufactured, tested and certified to relevant UL, NFPA, ISO, IEC, Mil Std., CE and CSA standards.

Base Control Functions

HMI Capability

Operator adjustments - The HMI includes provisions for many set up and adjustment functions.

Generator set hardware data - Access to the control and software part number, generator set rating in kVA and generator set model number is provided from the HMI or InPower.

Data logs - Includes engine run time, controller on time, number of start attempts, total kWh, and load profile (control logs data indicating the operating hours at percent of rated kW load, in 5% increments. The data is presented on the operation panel based on total operating hours on the generator.)

Fault history - Provides a record of the most recent fault conditions with control date and time stamp. Up to 32 events are stored in the control non-volatile memory.

Alternator data

- Voltage (single or three phase Line-to-Line and Line-to-Neutral)
- Current (single or three phase)
- kW, kVar, power factor, kVA (three phase and total)
- Frequency

AmpSentry: 3x current regulation for downstream tripping/motor inrush management. Thermal damage curve (3-phase short) or fixed timer (2 sec for 1- Phase Short or 5 sec for 2-Phase short).

Engine data

- Starting battery voltage
- Engine speed
- Engine temperature
- Engine oil pressure
- Engine oil temperature
- Intake manifold temperature
- Comprehensive Full Authority Engine (FAE) data (where applicable)

Service adjustments - The HMI includes provisions for adjustment and calibration of generator set control functions. Adjustments are protected by a password. Functions include:

Service adjustments (continued)

- Engine speed governor adjustments
- Voltage regulation adjustments
- Cycle cranking
- Configurable fault set up
- Configurable output set up
- Meter calibration
- Display language and units of measurement

Engine Control

SAE-J1939 CAN interface to full authority ECMs (where applicable). Provides data swapping between genset and engine controller for control, metering and diagnostics.

12 VDC/24 VDC battery operations - PowerCommand will operate either on 12 VDC or 24 VDC batteries.

Temperature dependent governing dynamics (with electronic governing) - modifies the engine governing control parameters as a function of engine temperature. This allows the engine to be more responsive when warm and more stable when operating at lower temperature levels.

Isochronous governing - (where applicable) Capable of controlling engine speed within +/-0.25% for any steady state load from no load to full load. Frequency drift will not exceed +/-0.5% for a 33 °C (60 °F) change in ambient temperature over an 8 hour period.

Droop electronic speed governing - Control can be adjusted to droop from 0 to 10% from no load to full load.

Remote start mode - It accepts a ground signal from remote devices to automatically start the generator set and immediately accelerate to rated speed and voltage. The remote start signal will also wake up the control from sleep mode. The control can incorporate a time delay start and stop.

Remote and local emergency stop - The control accepts a ground signal from a local (genset mounted) or remote (facility mounted) emergency stop switch to cause the generator set to immediately shut down. The generator set is prevented from running or cranking with the switch engaged. If in sleep mode, activation of either emergency stop switch will wakeup the control.

Sleep mode - The control includes a configurable low current draw state to minimize starting battery current draw when the genset is not operating. The control can also be configured to go into a low current state while in auto for prime applications or applications without a battery charger.

Engine starting - The control system supports automatic engine starting. Primary and backup start disconnects are achieved by one of two methods: magnetic pickup or main alternator output frequency. The control also supports configurable glow plug control when applicable.

Cycle cranking - Is configurable for the number of starting cycles (1 to 7) and duration of crank and rest periods. Control includes starter protection algorithms to prevent the operator from specifying a starting sequence that might be damaging.

Time delay start and stop (cooldown) - Configurable for time delay of 0-300 seconds prior to starting after receiving a remote start signal and for time delay of 0-600 seconds prior to shut down after signal to stop in normal operation modes. Default for both time delay periods is 0 seconds.

Alternator Control

The control includes an integrated three phase Line-to-Line sensing voltage regulation system that is compatible with shunt or PMG excitation systems. The voltage regulation system is a three phase full wave rectified and has an FET output for good motor starting capability.

Major system features include:

Digital output voltage regulation - Capable of regulating output voltage to within +/-1.0% for any loads between no load and full load. Voltage drift will not exceed +/- 1.5% for a 40 °C (104 °F) change in temperature in an eight hour period. On engine starting or sudden load acceptance, voltage is controlled to a maximum of 5% overshoot over nominal level. The automatic voltage regulator feature can be disabled to allow the use of an external voltage regulator.

Droop voltage regulation - Control can be adjusted to droop from 0-10% from no load to full load.

Torque-matched V/Hz overload control - The voltage roll-off set point and rate of decay (i.e. the slope of the V/Hz curve) is adjustable in the control.

Fault current regulation - PowerCommand will regulate the output current on any phase to a maximum of three times rated current under fault conditions for both single phase and three phase faults. In conjunction with a permanent magnet generator, it will provide three times rated current on all phases for motor starting and short circuit coordination purpose.

Protective Functions

On operation of a protective function the control will indicate a fault by illuminating the appropriate status LED on the HMI, as well as display the fault code and fault description on the LCD. The nature of the fault and time of occurrence are logged in the control. The service manual and InPower service tool provide service keys and procedures based on the service codes provided.

Protective functions include:

Battle Short Mode

When enabled and the *battle short* switch is active, the control will allow some shutdown faults to be bypassed. If a bypassed shutdown fault occurs, the fault code and description will still be annunciated, but the genset will not shutdown. This will be followed by a *fail to shutdown* fault. Emergency stop shutdowns and others that are critical for proper operation are not bypassed. Please refer to the control application guide or manual for list of these faults.

Derate

The derate function reduces output power of the genset in response to a fault condition. If a derate command occurs while operating on an isolated bus, the control will issue commands to reduce the load on the genset via contact closures or modbus.

Configurable Alarm and Status Inputs

The control accepts up to four alarm or status inputs (configurable contact closed to ground or open) to indicate a configurable (customer-specified) condition. The control is programmable for warning, shutdown or status indication and for labeling the input.

Emergency Stop

Annunciated whenever either emergency stop signal is received from external switch.

Full Authority Electronic Engine Protection

Engine fault detection is handled inside the engine ECM. Fault information is communicated via the SAE-J1939 data link for annunciation in the HMI.

General Engine Protection

Low and high battery voltage warning - Indicates status of battery charging system (failure) by continuously monitoring battery voltage.

Weak battery warning - The control system will test the battery each time the generator set is signaled to start and indicate a warning if the battery indicates impending failure.

Fail to start (overcrank) shutdown - The control system will indicate a fault if the generator set fails to start by the completion of the engine crank sequence.

Fail to crank shutdown - Control has signaled starter to crank engine but engine does not rotate.

Cranking lockout - The control will not allow the starter to attempt to engage or to crank the engine when the engine is rotating.

Alternator Protection

AmpSentry protective relay - A comprehensive monitoring and control system integral to the PowerCommand Control System that guards the electrical integrity of the alternator and power system by providing protection against a wide array of fault conditions in the generator set or in the load. It also provides single and three phase fault current regulation so that downstream protective devices have the maximum current available to quickly clear fault conditions without subjecting the alternator to potentially catastrophic failure conditions. Thermal damage curve (3-Phase short) or fixed timer (2 sec for 1-Phase short, 5 sec for 2-Phase short). See document R1053 for a full-size time over current curve.

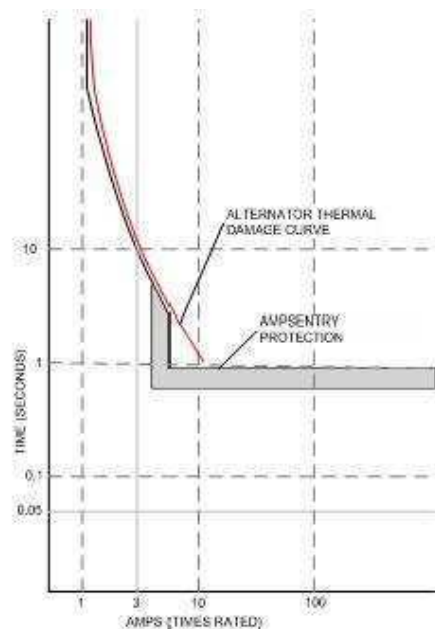

AmpSentry Maintenance Mode (AMM) - Instantaneous tripping, if AmpSentry Maintenance mode is active (50mS response to turn off AVR excitation/shutdown genset) for arc flash reduction when personnel are near genset.

High AC voltage shutdown (59) - Output voltage on any phase exceeds preset values. Time to trip is inversely proportional to amount above threshold. Values adjustable from 105-125% of nominal voltage, with time delay adjustable from 0.1-10 seconds. Default value is 110% for 10 seconds.

Low AC voltage shutdown (27) - Voltage on any phase has dropped below a preset value. Adjustable over a range of 50-95% of reference voltage, time delay 2-20 seconds. Default value is 85% for 10 seconds. Function tracks reference voltage. Control does not nuisance trip when voltage varies due to the control directing voltage to drop, such as during a V/Hz roll-off during synchronizing.

Under frequency shutdown (81 u) - Generator set output frequency cannot be maintained. Settings are adjustable from 2-10 Hz below reference governor set point, for a 5- 20 second time delay. Default: 6 Hz, 10 seconds.

Under frequency protection is disabled when excitation is switched off, such as when engine is operating in idle speed mode.

Over frequency shutdown/warning (81 o) - Generator set is operating at a potentially damaging frequency level. Settings are adjustable from 2-10 Hz above nominal governor set point for a 1-20 second time delay. Default: 6 Hz, 20 seconds, disabled.

Overcurrent warning/shutdown - Thresholds and time delays are configurable. Implementation of the thermal damage curve with instantaneous trip level calculated based on current transformer ratio and application power rating.

Loss of sensing voltage shutdown - Shutdown of generator set will occur on loss of voltage sensing inputs to the control.

Field overload shutdown - Monitors field voltage to shutdown generator set when a field overload condition occurs.

Over load (kW) warning - Provides a warning indication when engine is operating at a load level over a set point.

Adjustment range: 80-140% of application rated kW, 0-120 second delay. Defaults: 105%, 60 seconds.

Reverse power shutdown (32) - Adjustment range: 5-20% of standby kW rating, delay 1-15 seconds. Default: 10%, 3 seconds.

Reverse Var shutdown - Shutdown level is adjustable: 15-50% of rated Var output, delay 10-60 seconds. Default: 20%, 10 seconds.

Short circuit protection - Output current on any phase is more than 175% of rating and approaching the thermal damage point of the alternator. Control includes algorithms to protect alternator from repeated over current conditions over a short period of time.

Field Control Interface

Input signals to the PowerCommand control include:

- Coolant level (where applicable)
- Fuel level (where applicable)
- Remote emergency stop
- Remote fault reset
- Remote start
- Battleshort
- Rupture basin
- Start type signal
- Configurable inputs - Control includes (4) input signals from customer discrete devices that are configurable for warning, shutdown or status indication, as well as message displayed

Output signals from the PowerCommand control include:

- Load dump signal: Operates when the generator set is in an overload condition.
- Delayed off signal: Time delay based output which will continue to remain active after the control has removed the run command. Adjustment range: 0 – 120 seconds. Default: 0 seconds.

- Configurable relay outputs: Control includes (4) relay output contacts (3 A, 30 VDC). These outputs can be configured to activate on any control warning or shutdown fault as well as ready to load, not in auto, common alarm, common warning and common shutdown.
- Ready to load (generator set running) signal: Operates when the generator set has reached 90% of rated speed and voltage and latches until generator set is switched to off or idle mode.

Communications Connections Include:

- PC tool interface: This RS-485 communication port allows the control to communicate with a personal computer running InPower software.
- Modbus RS-485 port: Allows the control to communicate with external devices such as PLCs using Modbus protocol.
Note - An RS-232 or USB to RS-485 converter is required for communication between PC and control.
- Networking: This RS-485 communication port allows connection from the control to the other Cummins products.

Mechanical Drawings

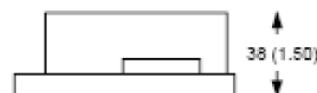
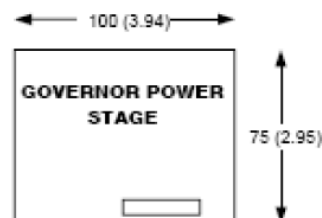
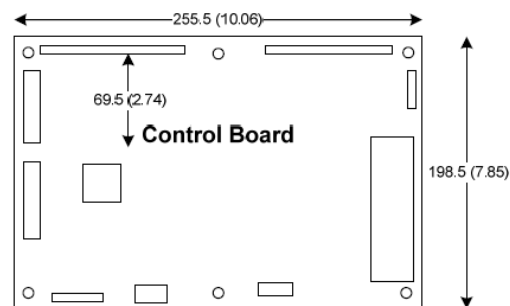

PowerCommand Human Machine Interface HMI320



Description

This control system includes an intuitive operator interface panel that allows for complete genset control as well as system metering, fault annunciation, configuration and diagnostics. The interface includes five genset status LED lamps with both internationally accepted symbols and English text to comply with customer's needs. The interface also includes an LED backlit LCD display with tactile feel soft-switches for easy operation and screen navigation. It is configurable for units of measurement and has adjustable screen contrast and brightness.

The *run/off/auto* switch function is integrated into the interface panel.

All data on the control can be viewed by scrolling through screens with the navigation keys. The control displays the current active fault and a time-ordered history of the five previous faults.

Features

- LED indicating lamps:
 - Genset running
 - Remote start
 - Not in auto
 - Shutdown
 - Warning
 - Auto
 - Manual and stop
- 320 x 240 pixels graphic LED backlight LCD.
- Four tactile feel membrane switches for LCD defined operation. The functions of these switches are defined dynamically on the LCD.
- Seven tactile feel membrane switches dedicated screen navigation buttons for up, down, left, right, ok, home and cancel.
- Six tactile feel membrane switches dedicated to control for auto, stop, manual, manual start, fault reset and lamp test/panel lamps.

- Two tactile feel membrane switches dedicated to control of circuit breaker (where applicable).
- Allows for complete genset control setup.
- Certifications: Suitable for use on generator sets that are designed, manufactured, tested and certified to relevant UL, NFPA, ISO, IEC, Mil Std., CE and CSA standards.
- LCD languages supported: English, Spanish, French, German, Italian, Greek, Dutch, Portuguese, Finnish, Norwegian, Danish, Russian and Chinese Characters.

Communications connections include:

- PC tool interface - This RS-485 communication port allows the HMI to communicate with a personal computer running InPower.
- This RS-485 communication port allows the HMI to communicate with the main control board.

Mechanical Drawing

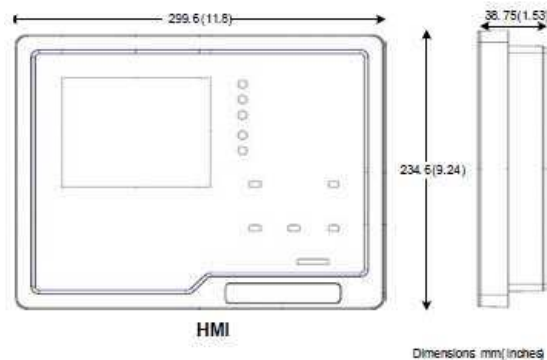

Software

InPower (beyond 6.5 version) is a PC-based software service tool that is designed to directly communicate to PowerCommand generator sets and transfer switches, to facilitate service and monitoring of these products.

Environment

The control is designed for proper operation without recalibration in ambient temperatures from $-40\text{ }^{\circ}\text{C}$ to $+70\text{ }^{\circ}\text{C}$ ($-40\text{ }^{\circ}\text{F}$ to $158\text{ }^{\circ}\text{F}$) and for storage from $-55\text{ }^{\circ}\text{C}$ to $+80\text{ }^{\circ}\text{C}$ ($-67\text{ }^{\circ}\text{F}$ to $176\text{ }^{\circ}\text{F}$). Control will operate with humidity up to 95%, non-condensing.

The HMI is designed for proper operation in ambient temperatures from $-20\text{ }^{\circ}\text{C}$ to $+70\text{ }^{\circ}\text{C}$ ($-4\text{ }^{\circ}\text{F}$ to $158\text{ }^{\circ}\text{F}$) and for storage from $-30\text{ }^{\circ}\text{C}$ to $+80\text{ }^{\circ}\text{C}$ ($-22\text{ }^{\circ}\text{F}$ to $176\text{ }^{\circ}\text{F}$).

The control board is fully encapsulated to provide superior resistance to dust and moisture. Display panel has a single membrane surface, which is impervious to effects of dust, moisture, oil and exhaust fumes. This panel uses a sealed membrane to provide long reliable service life in harsh environments.

The control system is specifically designed and tested for resistance to RFI/EMI and to resist effects of vibration to provide a long reliable life when mounted on a generator set. The control includes transient voltage surge suppression to provide compliance to referenced standards.

Certifications

PowerCommand meets or exceeds the requirements of the following codes and standards:

- NFPA 110 for level 1 and 2 systems.
- ISO 8528-4: 1993 compliance, controls and switchgear.
- CE marking: The CE marking is only valid when equipment is used in a fixed installation application. Material compliance declaration is available upon request.
- UKCA marking: The UKCA marking is only valid when equipment is used in a fixed installation application. Material compliance declaration is available upon request.
- EN50081-1,2 residential/light industrial emissions or industrial emissions.
- EN50082-1,2 residential/light industrial or industrial susceptibility.
- ISO 7637-2, level 2; DC supply surge voltage test.
- Mil Std 202C, Method 101 and ASTM B117: Salt fog test.
- UL 6200 recognized and suitable for use on UL 2200 Listed generator sets.
- CSA C282-M1999 compliance
- CSA 22.2 No. 14 M91 industrial controls.
- PowerCommand control systems and generator sets are designed and manufactured in ISO 9001 certified facilities.

Warranty

All components and subsystems are covered by an express limited one year warranty. Other optional and extended factory warranties and local distributor maintenance agreements are available.



**For more information contact your local Cummins distributor
or visit power.cummins.com**

Our energy working for you.™



Specification Sheet



Enclosures and Tanks

250-1000 kW Gensets



Enclosure Standard Features

- 14-gauge steel construction (panels)
- Stainless steel hardware
- Zinc phosphate pretreatment, e-coat primer and super durable powder topcoat paint minimize corrosion and color fade
- Package listed to UL 2200
- Designed to satisfy national electrical code installation requirements
- Fuel and electrical stub-up area within enclosure perimeter
- Fixed louvers
- Cambered roof prevents water accumulation
- Recessed, lockable doors in two sides
- Retainers hold doors open for easy access
- Enclosed exhaust silencer ensures safety and protects against rust
- Rain cap
- Exterior oil and coolant drains with interior valves for ease of service
- Rodent barriers on inlet
- Non-hydroscopic sound attenuating material
- Side mounted controls and circuit breakers
- Easy access lifting points for spreader bars
- Dual vibration isolation system (250-500 kW)
- Spring vibration isolation system (600-1000 kW)
- Enclosure mounts to lifting base or fuel tank (250-500 kW)
- Enclosure mounts to lifting base (600-1000 kW)
- Factory pre-assembled package
- Designed for outdoor use only
- Externally mounted emergency stop button for operator safety (optional on 250-500 kW)
- Horizontal air discharge to prevent leaf and snow accumulation (600-1000 kW)

Options

- **Three levels of sound attenuation**
- Motorized louvers to protect from ice and snow accumulation (available on air inlet for all models and on air outlet on level II, 250-500 kW enclosures only)
- Horizontal air discharge, sound level 2 only (250-500 kW)
- Aluminium construction with roll-coated polymer paint
- **Wind rated to 150 mph**
- Neutral sandstone paint color
- **Factory mounted battery charger**
- External 120 VAC service outlet
- Rain hoods for air inlet (250-500 kW)
- Lifting base in lieu of a sub-base tank (250-500 kW)
 - Pre-wired AC distribution package
 - 100 amp (250-500 kW) or 150 amp (600-1000 kW) main circuit breaker; connected to 120 VAC Line-Neutral and 208 or 240 VAC Line-Line, spare breaker positions and capacity for future upgrades (600-1000 kW)
 - GFCI protected internal 120 VAC service receptacle
 - GFCI protected weather proof external 120 volt service receptacle
 - All factory installed AC powered features pre-wired into load center
- Interior lights – 120 volt (600-1000 kW)
- Rain hoods for air inlet (250-500 kW)
- Seismic isolators available (600-1000 kW)

Fuel Tanks

Standard sub-base tank features

- UL 142 Listed
- ULC-S601-07 Listed
- NFPA37 compliant
- Dual walled, steel construction
- Emergency tank and rupture basin vents
- Tank mounted mechanical fuel gauge
- Fuel supply and return tubes
- Top mounted leak detection float switch
- Low and high level fuel switches
- Mounting brackets for optional pump and control (250-500 kW)
- Integral lifting points

Sub-base tank options

- Pre-wired fuel pump and control
- Fuel overfill alarm – internal or external
- Overflow and tank fill plugs
- Five gallon spill fill box – internal or external
- Fill pipe extender
- Local code approvals available

200-500 kW Dual Wall Sub-base Fuel Tanks – usable operating hours

Genset model (60 Hz)	Gallons /hour at full load	270 gallon tank	300 gallon tank	400 gallon tank	500 gallon tank	600 gallon tank	660 gallon tank	720 gallon tank	850 gallon tank	1420 gallon tank	1470 gallon tank	1700 gallon tank	2050 gallon tank	2525 gallon tank
250 DQDAA	20	14	15	20	25	30	33	36		72	74		104	
275 DQDAB	21	13	14	19	24	29	31	34		66	70		96	
300 DQDAC	23	12	13	17	22	26	29	31		61	64		88	
300 DQHAB	23	12	13	17	22	26	29		37			74		
450 DFEJ	30	9	10	13	17	20	22		28			57		84
500 DFEK	34	8	9	11	15	18	19		25			50		74

Operating hours are measured at 60 Hz, standby rating.

600-1000 kW Dual Wall Sub-base Fuel Tanks – usable operating hours

Genset model	Gallons /hour at full load	200 gallon tank	660 gallon tank	1000 gallon tank	1500 gallon tank	2000 gallon tank	2400 gallon tank
600 DQCA	42	5	16	24	36	48	57
600 DQPAA	45	4	15	22	33	44	53
650 DQPAB	50	4	13	20	30	40	48
750 DQCB	51	4	13	20	29	39	47
750 DQFAA	53	4	12	19	28	38	45
800 DQCC	53	4	12	19	28	38	45
800 DQFAB	56	4	12	18	27	37	43
900 DQFAC	64	3	10	16	23	31	38
1000 DQFAD	72	3	9	14	21	28	33

*3000 gallon tank offered as an accessory kit – refer to NAAC-5853 spec sheet.

- Operating hours are measured at 60 Hz, standby rating.
- Up to 90% fill alarm to comply with NFPA30, operating capacity is reduced by 10%.

Enclosure Package Sound Pressure Levels @ 7 meters dB(A)

Genset model	Weather protective enclosure (F200, F203)	QuietSite level 1 sound attenuated enclosure (F201, F204)	QuietSite level 2 sound attenuated enclosure (F202, F205)
250 DQDAA	90	88	72
275 DQDAB	90	88	73
300 DQDAC	90	88	73
300 DQHAB	89	88	76
450 DFEJ	88	85	74
500 DFEK	89	87	73
600 DQCA	90.6/86*	79.3/78*	74.1/73*
600 DQPAA	89.10	80.70	74.70
650 DQPAB	89.70	81.40	75
750 DQCB	91.1/87*	79.9/79*	75.3/74*
750 DQFAA	87.8	77.8	73.8
800 DQCC	91.3/87*	80.2/79*	75.7/74*
800 DQFAB	88.1	78.3	74
900 DQFAC	88.8	79.1	74.6
1000 DQFAD	89.6	80.1	75.3

- All data is 60 Hz, full load standby rating, steel enclosures only.
- Data is a measured average of 8 positions.
- Sound levels for aluminium enclosures are approximately 2 dB(A) higher than listed sound levels for steel enclosures.
- * Sound data with seismic feature codes L228-2 (IBC) and/or L225-2 (OSHPD)

Provide generator pad 4" larger than enclosure dimensions.

Package Dimensions of Enclosure, Exhaust System, and UL Tank



250-500 kW

Tank size (gal)	Weather protective package length (in)	QuietSite level I package length (in)	QuietSite level 2 package length (in)	Width (in)	Height (in)	Weather protective package weight (lbs)	QuietSite level 1 package weight (lbs)	QuietSite level 2 package weight (lbs)
270	188	188	222	82	106	4991	5471	6711
300	188	188	222	82	104	5648	6073	6991
400	188	188	222	82	106	5833	6258	7176
500	188	188	222	82	108	5956	6381	7299
600	188	188	222	82	111	6116	6541	7459
660	188	188	222	82	113	6235	6660	7578
720	188	188	222	82	114	6174	6599	7517
850	188	188	222	82	118	6529	6954	7872
1420	200	200	222	82	128	6863	7343	8583
1470	192	192	222	82	128	7253	7733	8973
1700	234	234	234	82	128	7982	8407	9325
2050	284	284	284	82	128	8383	8863	10103
2525	346	346	346	82	128	9391	9871	11111
Lifting base	188	188	222	82	100	4335	4760	5678

600-1000 kW

Tank size (gal)	Weather protective package length (in)	QuietSite level I package length (in)	QuietSite level 2 package length (in)	Width (in)	Height (in)	Weather protective package weight (lbs)	QuietSite level 1 package weight (lbs)	QuietSite level 2 package weight (lbs)
200	260	303	315	98	137	10194	13074	14954
660	260	303	315	98	137	9586	12466	14346
1000	260	303	315	98	141	10117	12997	14877
1500	260	303	315	98	146	10677	13557	15437
2000	292	327	327	98	143	11959	14839	16719
2400	338	338	338	98	143	12961	15841	17721

- This weight does not include the generator set. Consult your local Cummins distributor or the appropriate generator specification sheet.
- Width is 86" lifting eye to lifting eye (250-500 kW), 102" lifting eye to lifting eye (600-1000 kW).
- Height - Florida, Michigan, and Suffolk add 6.4" (250-500 kW) or 2" (600-1000 kW) for bottom space.
- Maximum length emergency vent removed.

	CSA - The generator set is CSA certified to product class 4215-01.
	UL - The generator set is available listed to UL 2200, stationary engine generator assemblies. The PowerCommand® control is listed to UL 508 - Category NITW7 for U.S. and Canadian usage.

For more information contact your local Cummins distributor or visit power.cummins.com

Our energy working for you.™





2024 EPA Tier 3 Exhaust Emission Compliance Statement

250DQDAA

Stationary Emergency 60 Hz Diesel Generator Set

Compliance Information:

The engine used in this generator set complies with Tier 3 emissions limit of U.S. EPA New Source Performance Standards for stationary emergency engines under the provisions of 40 CFR 60 Subpart IIII.

Engine Manufacturer:	Cummins Inc.
EPA Certificate Number:	RCEXL0540AAB-009
Effective Date:	05/01/2023
Date Issued:	05/01/2023
EPA Engine Family (Cummins Emissions Family):	RCEXL0540AAB

Engine Information:

Model:	QSL/QSL9/QSL9-G7 NR3	Bore:	4.49 in. (114 mm)
Engine Nameplate HP:	464	Stroke:	5.69 in. (145 mm)
Type:	4 Cycle, In-line, 6 Cylinder Diesel	Displacement:	543 cu. in. (8.9 liters)
Aspiration:	Turbocharged and CAC	Compression ratio:	16.1:1
Emission Control Device:		Exhaust stack diameter:	6 in. (152 mm)

Diesel Fuel Emission Limits

D2 Cycle Exhaust Emissions

	Grams per BHP-hr			Grams per kWm-hr		
	NO _x + NMHC	CO	PM	NO _x + NMHC	CO	PM
EPA Emissions Limit	3.0	2.6	0.15	4.0	3.5	0.20

Test methods: EPA emissions recorded per 40 CFR Part 60, 89, 1039, 1065 and weighted at load points prescribed in the regulations for constant speed engines.

Diesel fuel specifications: Cetane number: 40-50, Reference: ASTM D975 No. 2-D. 300-500 ppm Sulfur

Reference conditions: Air Inlet Temperature: 25 °C (77 °F), Fuel Inlet Temperature: 40 °C (104 °F). Barometric Pressure: 100 kPa (29.53 in Hg), Humidity: 10.7 g/kg (75 grains H₂O/lb) of dry air; required for NO_x correction, Restrictions: Intake Restriction set to a maximum allowable limit for clean filter; Exhaust Back Pressure set to a maximum allowable limit..

Tests conducted using alternate test methods, instrumentation, fuel or reference conditions can yield different results. Engine operation with excessive air intake or exhaust restriction beyond published maximum limits, or with improper maintenance, may result in elevated emission levels.



Exhaust emission data sheet

250DQDAA

60 Hz Diesel generator set EPA NSPS Stationary emergency

Engine information:

Model:	Cummins Inc. QSL9-G7 NR3	Bore:	4.49 in. (114 mm)
Type:	4 cycle, in-line, 6 cylinder diesel	Stroke:	5.69 in. (145 mm)
Aspiration:	Turbocharged and CAC	Displacement:	543 cu. in. (8.9 liters)
Compression ratio:	16.1:1		
Emission control device:	Turbocharger and CAC		

	<u>1/4</u>	<u>1/2</u>	<u>3/4</u>	<u>Full</u>	<u>Full</u>
<u>Performance data</u>	<u>Standby</u>	<u>Standby</u>	<u>Standby</u>	<u>Standby</u>	<u>Prime</u>
Engine HP @ Stated load (1800 RPM) ✓	95.5	191	286.5	382	312
Fuel consumption (gal/Hr)	5.95	10.50	15.05	19.59	17.59
Exhaust gas flow (CFM)	968.7	1506.1	1906.3	2149.6	NA
Exhaust gas temperature (°F)	634	758	844	940	710
<u>Exhaust emission data</u>					
HC (Total unburned hydrocarbons)	0.33	0.162	0.09	0.046	0.052
NOx (Oxides of nitrogen as NO2)	1.67	1.66	2.19	3.42	2.18
CO (Carbon monoxide)	3.18	3.18	1.85	0.77	NA
PM (Particular Matter)	0.22	0.16	0.08	0.04	NA
SO2 (Sulfur dioxide)	0.142	0.132	0.123	0.115	0.12
Smoke (Bosch)	0.53	0.438	0.382	0.238	0.202

All values are Grams per HP-Hour

Test conditions

Data was recorded during steady-state rated engine speed (± 25 RPM) with full load ($\pm 2\%$). Pressures, temperatures, and emission rates were stabilized.

Fuel specification:	46.5 Cetane Number, 0.035 Wt.% Sulfur; Reference ISO8178-5, 40 CFR86.1313-98 Type 2-D and ASTM D975 No. 2-D.
Fuel temperature	99 \pm 9 °F (at fuel pump inlet)
Intake air temperature:	77 \pm 9 °F
Barometric pressure:	29.6 \pm 1 in. Hg
Humidity:	NOx measurement corrected to 75 grains H2O/lb dry air
Reference standard:	ISO 8178

The NOx, HC, CO and PM emission data tabulated here were taken from a single engine under the test conditions shown above. Data for the other components are estimated. These data are subjected to instrumentation and engine-to-engine variability. Field emission test data are not guaranteed to these levels. Actual field test results may vary due to test site conditions, installation, fuel specification, test procedures and instrumentation. Engine operation with excessive air intake or exhaust restriction beyond published maximum limits, or with improper maintenance, may result in elevated emission levels.

Sound Pressure Level @ 7 meters, dB(A)

See Notes 1-8 listed below

Configuration		Measurement Location Number								Average
		1	2	3	4	5	6	7	8	
Standard - Unhoused	Infinite Exhaust	88.2	91.6	91.3	92.2	89.1	91.6	88.1	91.4	90.7
F200 -Weather	Mounted Muffler	85.5	90.8	90.8	90.6	87.4	91.9	90	91.8	90.3
F201 - Quiet Site II First Stage	Mounted Muffler	90.4	89.3	81	77.5	77.8	76.4	80.9	90.3	86.3
F202 - Quiet Site II Second Stage	Mounted Muffler	70.1	71.4	69.5	71	74.4	72	68.7	71.3	71.4

Acoustical consultant to confirm compliance with noise ordinance at property line

Sound Power Level, dB(A)

See Notes 2-6, 9, 10 listed below

Configuration		Octave Band Center Frequency (Hz)								Overall Sound Power Level
		63	125	250	500	1000	2000	4000	8000	
Standard - Unhoused	Infinite Exhaust	83.8	95	105.8	109.8	112	111.8	111.1	108.3	118.1
F200 -Weather	Mounted Muffler	89.4	98.1	106.6	109.3	112.7	111.6	109.3	105.3	117.8
F201 - Quiet Site II First Stage	Mounted Muffler	99.7	105.7	107	107.2	108.8	107.5	103.4	96.1	114.9
F202 - Quiet Site II Second Stage	Mounted Muffler	78.4	87.3	92.8	93	93.7	94	91.9	86.4	100.6

Exhaust Sound Pressure Level @ 1 meter, dB(A)

Open Exhaust (No Muffler Rated Load)	Octave Band Center Frequency (Hz)								Sound Pressure Level
	63	125	250	500	1000	2000	4000	8000	
	79.2	90.9	99.9	102.7	109.4	110.9	111	110	116.7

Note:

- Position 1 faces the engine front. The positions proceed around the generator set in a counter-clockwise direction in 45° increments. All positions are at 7m (23 ft) from the surface of the generator set and 1.2m (48") from floor level.
- Sound levels are subject to instrumentation, measurement, installation and manufacturing variability.
- Sound data with remote-cooled generator sets are based on rated loads without cooling fan noise.
- Sound levels for aluminum enclosures are approximately 2 dB(A)s higher than listed sound levels for steel enclosures.
- Sound data for generator set with infinite exhaust do not include exhaust noise.
- Data is based on full rated load with standard radiator-cooling fan package
- Sound Pressure Levels are measured per ANSI S1.13 and ANSI S12.18, as applicable.
- Reference sound pressure is 20 µPa.
- Sound Power Levels per ISO 3744 and ISO 8528-10, as applicable.
- Reference power = 1 pw (10⁻¹²W)
- Exhaust Sound Pressure Levels are per ISO 6798, as applicable.



Prototype Test Support (PTS) 60 Hz test summary



Generator set models		Representative prototype	
250DQDAA	275DQDAB	Model:	300DQDAC
300DQDAC		Alternator:	HC4F
		Engine:	QSL9-G5

The following summarizes prototype testing conducted on the designated representative prototype of the specified models. This testing is conducted to verify the complete generator set electrical and mechanical design integrity. Prototype testing is conducted only on generator sets not sold as new equipment.

Maximum surge power: 315 kW

The generator set was evaluated to determine the stated maximum surge power.

Maximum motor starting: 1372 kVA ✓

The generator set was tested to simulate motor starting by applying the specified kVA load at low lagging power factor (0.4 or lower). With this load applied, the generator set recovered to a minimum of 90% rated voltage.

Torsional analysis and testing:

The generator set was tested to verify that the design is not subjected to harmful torsional stresses. A spectrum analysis of the transducer output was conducted over the speed range of 1350 to 1950 RPM.

Cooling system: 50 °C ambient
0.5 in. H₂O restriction

The cooling system was tested to determine ambient temperature and static restriction capabilities. The test was performed at full rated load in elevated ambient temperature under static restriction conditions.

Durability:

The generator set was subjected to a minimum 500 hour endurance test operating at variable load up to the Standby rating based upon MIL-STD-705 to verify structural soundness and durability of the design.

Electrical and mechanical strength:

The generator set was tested to several single phase and three phase faults to verify that the generator can safely withstand the forces associated with short circuit conditions. The generator set was capable of producing full rated output at the conclusion of the testing.

Steady state performance:

The generator set was tested to verify steady state operating performance was within the specified maximum limits.

Voltage regulation:	± 0.50%	✓
Random voltage variation:	± 0.50%	✓
Frequency regulation:	Isochronous	✓
Random frequency variation:	± 0.25%	✓

Transient performance:

The generator set was tested with the standard alternator to verify single step loading capability as required by NFPA 110. Voltage and frequency response on load addition or rejection were evaluated. The following results were recorded:

<u>Full load acceptance:</u>	
Voltage dip:	30.5% ✓
Recovery time:	2.1 seconds
Frequency dip:	12.8%
Recovery time:	2.6 seconds

<u>Full load rejection:</u>	
Voltage rise:	15.8%
Recovery time:	0.7 seconds
Frequency rise:	3.5%
Recovery time:	2.8 seconds

Harmonic analysis:

(per MIL-STD-705B, method 601.4)

Harmonic	<u>Line to Line</u>		<u>Line to Neutral</u>	
	<u>No load</u>	<u>Full load</u>	<u>No load</u>	<u>Full load</u>
3	0.09	0.035	0.16	0.054
5	0.62	1.95	0.66	2
7	0.58	0.73	0.6	0.72
9	0.028	0.029	0.058	0.098
11	0.7	0.37	0.7	0.36
13	0.13	0.32	0.33	0.36
15	0.05	0.016	0.08	0.076



Cooling System Data

DQDAA
QSL9-G7

EPA NSPS Stationary Emergency

High Ambient Air Temperature Radiator Cooling System with Seismic (L228-2 or L225-2)

	Fuel Type	Duty	Rating (kW)	Max cooling @ air flow static restriction, unhooded (inches water/mm water)					Housed in free air, no air discharge restriction		
				0.0/0.0	0.25/6.4	0.5/12.7	0.75/19.1	1.0/25.4	Weather	Sound Level 1	Sound Level 2
				Maximum allowable ambient temperature, degree C							
60 Hz	Diesel	Standby	250	55	54	53	52	51	47	N/A	N/A
		Prime	225	52	52	50	50	50	45	N/A	N/A

High Ambient Air Temperature Radiator Cooling System

	Fuel Type	Duty	Rating (kW)	Max cooling @ air flow static restriction, unhooded (inches water/mm water)					Housed in free air, no air discharge restriction		
				0.0/0.0	0.25/6.4	0.5/12.7	0.75/19.1	1.0/25.4	Weather	Sound Level 1	Sound Level 2
				Maximum allowable ambient temperature, degree C							
60 Hz	Diesel	Standby	250	55	55	55	55	55	55	N/A	N/A
		Prime	225	55	55	55	55	55	55	N/A	N/A

Notes:

1. Data shown are anticipated cooling performance for typical generator set.
2. Cooling data is based on 1000 ft (305 m) site test location.
3. Generator set power output may need to be reduced at high ambient conditions. Consult generator set data sheet for derate schedules.
4. Cooling performance may be reduced due to several factors including but not limited to: Incorrect installation, improper operation, fouling of the cooling system, and other site installation variables.



Alternator data sheet

Frame size: **HCI434E**

Characteristics		1-brg w/coupling adapter							
Weights:	Stator assembly:	1014 lb	460 kg						
	Rotor assembly:	906 lb	411 kg						
	Complete assembly:	2284 lb	1036 kg						
Maximum speed:		2250 rpm							
Excitation current:	Full load:	2.00 Amps							
	No load:	0.50 Amps							
Insulation system:	Class H throughout								
3 ϕ Ratings (0.8 power factor)		60 Hz (winding no)				50 Hz (winding no)			
	(Based on specific temperature rise at 40° C ambient temperature)	<u>110/190</u> <u>220/380</u> (311)	<u>120/208</u> <u>240/416</u> (311)	<u>139/240</u> <u>277/480</u> (311)	<u>347/600</u> (17)	<u>110/190</u> <u>220/380</u> (311)	<u>115/200</u> <u>230/400</u> (311)	<u>120/208</u> <u>240/415</u> (311)	<u>127/220</u> <u>254/440</u> (311)
150° C rise ratings	kW	292	336	368	368	296	296	296	296
	kVA	365	420	460	460	370	370	370	370
125° C rise ratings	kW	290	320	352	352	280	280	280	280
	kVA	363	400	440	440	350	350	350	350
105° C rise ratings	kW	265	292	320	320	256	256	256	256
	kVA	331	365	400	400	320	320	320	320
80° C rise ratings	kW	230.4	252	277.6	280	220	220	220	212
	kVA	288	315	347	350	275	275	275	265
Reactances (per unit \pm 10%)		<u>110/190</u> <u>220/380</u> (311)	<u>120/208</u> <u>240/416</u> (311)	<u>139/240</u> <u>277/480</u> (311)	<u>347/600</u> (07)	<u>110/190</u> <u>220/380</u> (311)	<u>115/200</u> <u>230/400</u> (311)	<u>120/208</u> <u>240/415</u> (311)	<u>127/220</u> <u>254/440</u> (311)
	(Based on full load at 125° C rise rating)								
Synchronous		3.77	3.47	2.87	2.89	3.01	2.71	2.52	2.24
Transient		0.22	0.21	0.17	0.19	0.20	0.18	0.17	0.15
Subtransient		0.16	0.15	0.12	0.14	0.15	0.13	0.11	0.11
Negative sequence		0.30	0.28	0.23	0.23	0.24	0.22	0.20	0.18
Zero sequence		0.11	0.10	0.08	0.08	0.10	0.09	0.08	0.07
Motor starting		<u>Broad Range</u>			<u>600</u>	<u>Broad Range</u>			
Maximum kVA (90% sustained voltage)		1210			1210	912			
Time constants (sec)		<u>Broad Range</u>			<u>600</u>	<u>Broad Range</u>			
Transient		0.080			0.080	0.080			
Subtransient		0.019			0.019	0.019			
Open circuit		1.700			1.700	1.700			
DC		0.018			0.018	0.018			



Alternator data sheet

Frame size: **HCI434E**

Windings	(@ 20° C)	Broad Range	600	Broad Range
Stator resistance	(Line to Line, Ohms)	0.0200	0.0300	0.0200
Rotor resistance	(Ohms)	1.1700	1.1700	1.1700
Number of leads		12	6	12

Single phase power can be taken up to 50% of 3 phase-ratings

Winding 311 THREE PHASE EFFICIENCY CURVES

**50
Hz**

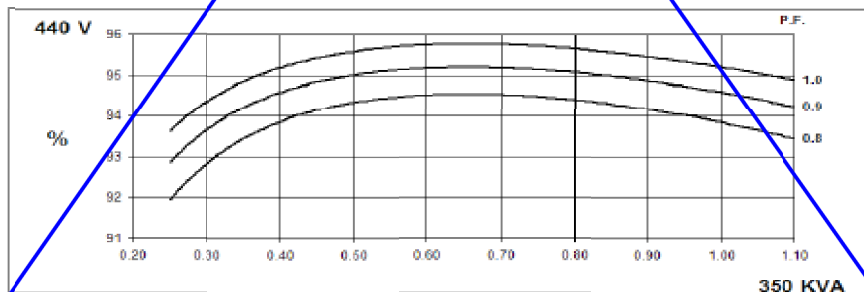
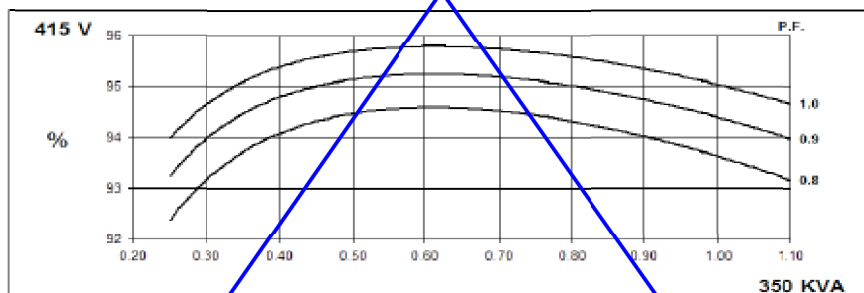
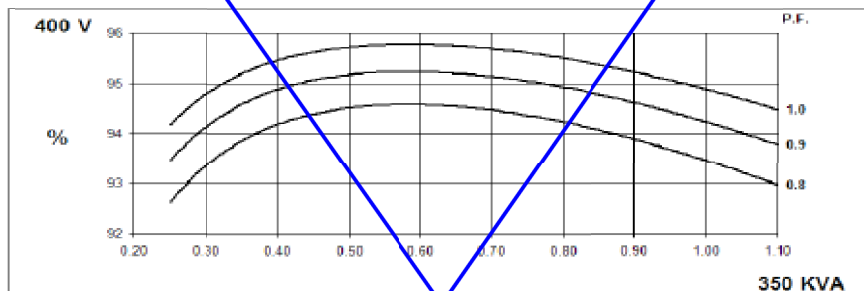
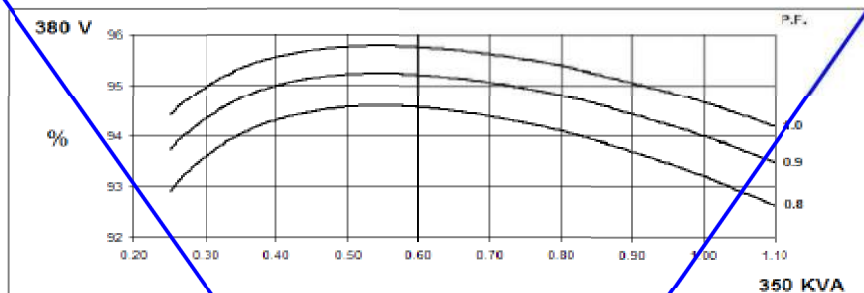



Alternator data sheet

Frame size: HCl434E

**60
Hz**

**Winding 311
THREE PHASE EFFICIENCY CURVES**

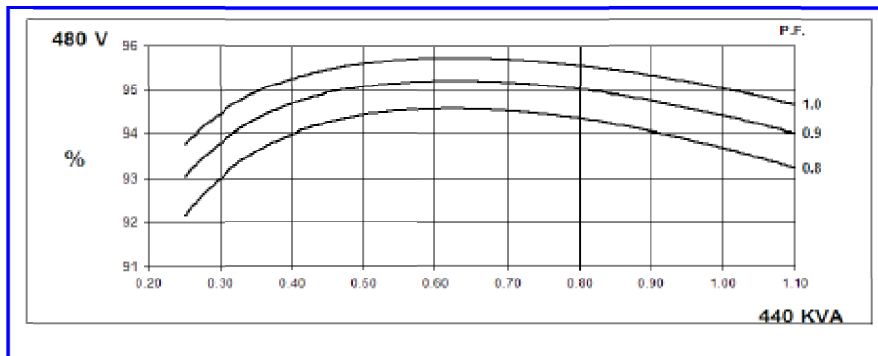
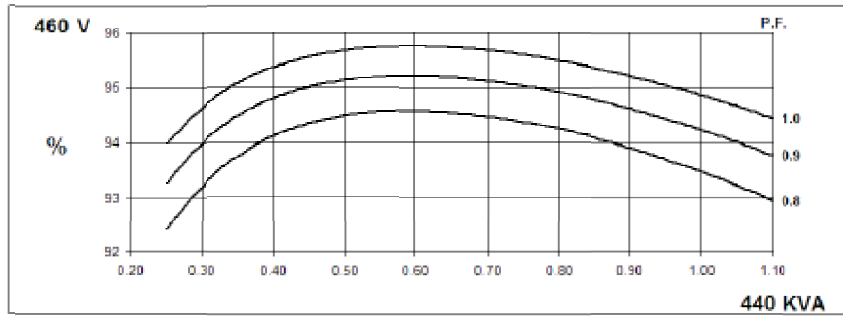
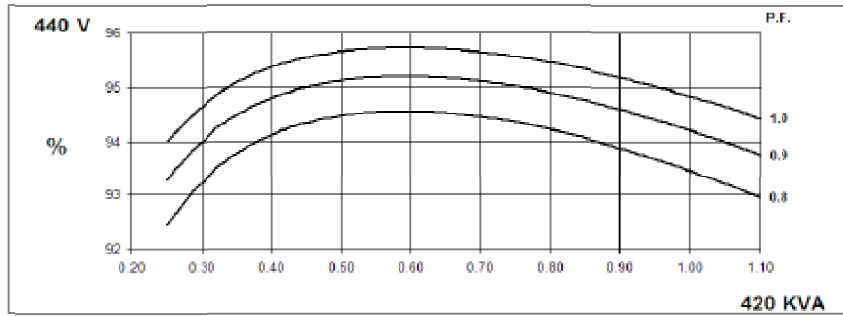
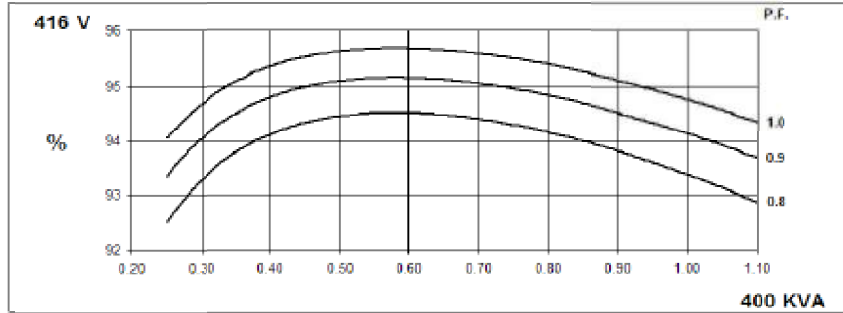



Alternator data sheet

Frame size: HCI434E

**Winding 311
Locked Rotor Motor Starting Curve**

**50
Hz**

MX

SX

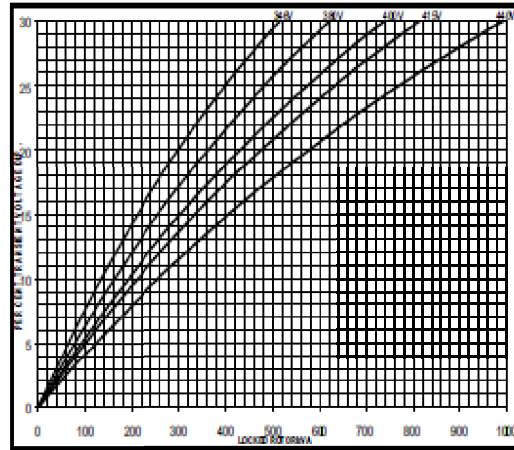
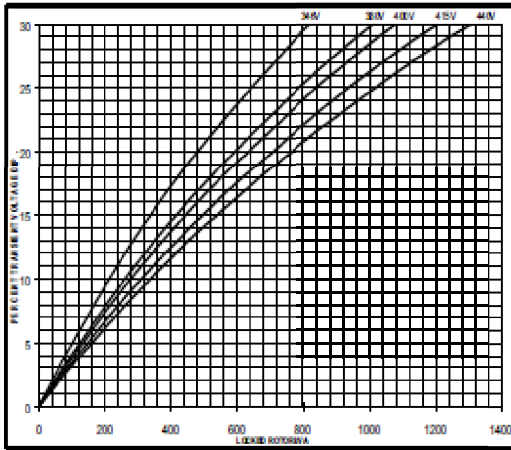

**60
Hz**

MX

SX

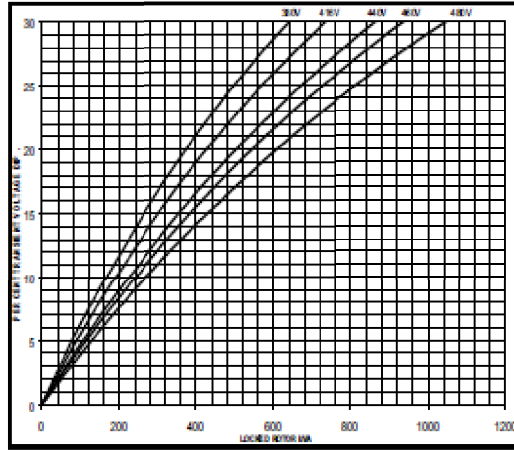
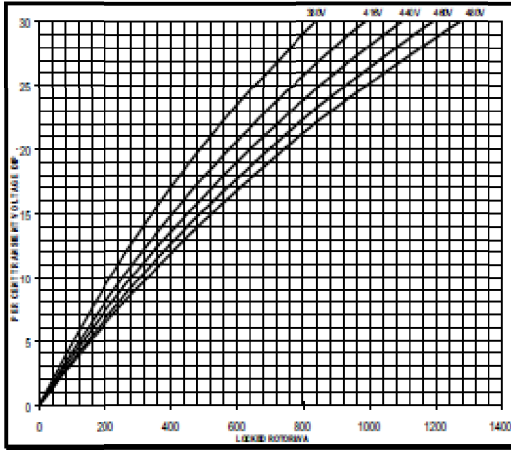



Alternator data sheet

Frame size: **HCI434E**

Three-phase Short Circuit Decrement Curve. No-load Excitation at Rated Speed
Based on star (wye) connection.

**50
Hz**

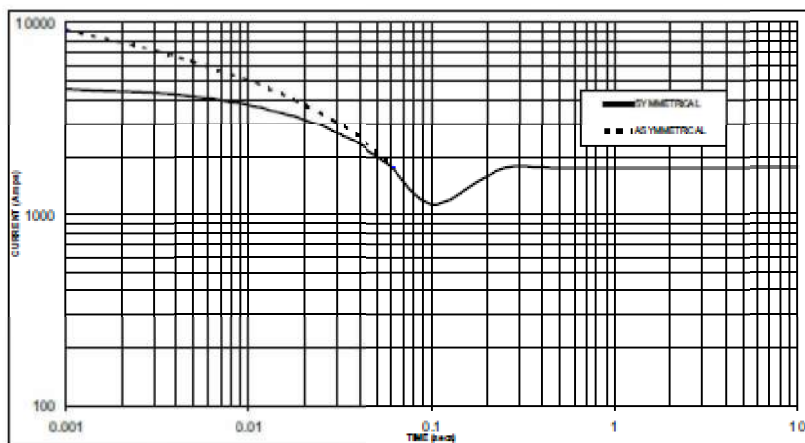

Sustained Short Circuit = 1,750 Amps

**60
Hz**

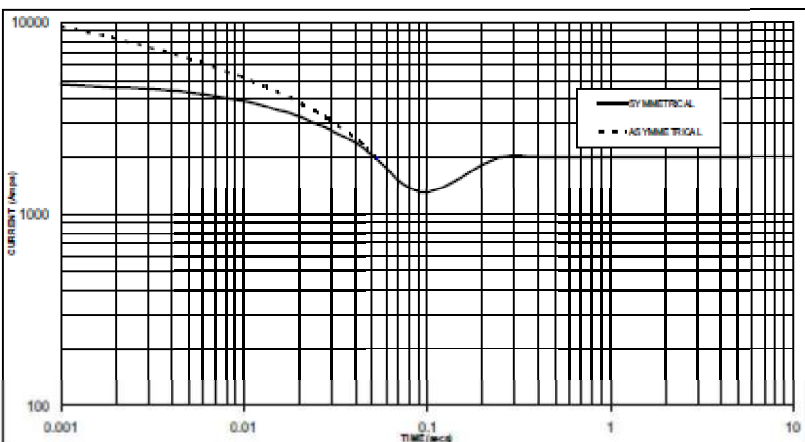

Sustained Short Circuit = 2,000 Amps

Note 1

The following multiplication factors should be used to adjust the values from curve between time 0.001 seconds and the minimum current point in respect of nominal operating voltage :

50Hz		60Hz	
Voltage	Factor	Voltage	Factor
380v	X 1.00	416v	X 1.00
400v	X 1.05	440v	X 1.06
415v	X 1.09	460v	X 1.10
440v	X 1.16	480v	X 1.15

The sustained current value is constant irrespective of voltage level

Note 2

The following multiplication factor should be used to convert the values calculated in accordance with NOTE 1 to those applicable to the various types of short circuit :

	3-phase	2-phase L-L	1-phase L-N
Instantaneous	x 1.00	x 0.87	x 1.30
Minimum	x 1.00	x 1.80	x 3.20
Sustained	x 1.00	x 1.50	x 2.50
Max. sustained duration	10 sec.	5 sec.	2 sec.

All other times are unchanged

Note 3

Curves are drawn for Star (Wye) connected machines. For other connection the following multipliers should be applied to current values as shown :

Parallel Star = Curve current value X 2

Series Delta = Curve current value X 1.732



VMC GROUP
THE POWER OF TOGETHER™



CERTIFICATE OF COMPLIANCE

SEISMIC DESIGN OF NONSTRUCTURAL COMPONENTS AND SYSTEMS



Certification No.

VMA-50957-01C (Revision 12)

Expiration Date: 6/30/2026

Certification Parameters:

The nonstructural products (mechanical and/or electrical components) listed on this certificate are CERTIFIED¹ FOR SEISMIC APPLICATIONS in accordance with the following building code² releases.

IBC 2015, 2012, 2009, 2006

The following model designations, options, and accessories are included in this certification. Reference report number VMA-50957-01 as issued by The VMC Group for a complete list of certified models, included accessories/options, and certified installation methods.

Cummins Power Generation, Inc.; Diesel Gensets
DSGAA-E, DSHAD, DQDAA-C, DQHAA-B, DFEJ-K; 100kW - 500kW

The above referenced equipment is APPROVED for seismic application when properly installed³, used as intended, and contains a Seismic Certification Label referencing this Certificate of Compliance⁴. As limited by the tabulated values, below grade, grade, and roof-level installations, installations in essential facilities, for life safety applications, and/or of equipment containing hazardous contents are permitted and included in this certification with an Equipment Importance Factor assigned as $I_p=1.5$. The equipment is qualified by successful seismic shake table testing at the nationally recognized University of California Berkeley Pacific Earthquake Engineering Research Center under the review of the ISO Accredited Product Certification Agency, the VMC Group.

Certified Seismic Design Levels			
Certified IBC	Importance $I_p \leq 1.5$ Soil Classes A-E Risk Categories I-IV Design Categories A-F	z/h ≤ 1.0	z/h = 0.0
		$S_{DS} \leq 0.647 g$	$S_{DS} \leq 1.940 g$

Certified Seismic Installation Methods ⁸	
External Isolation Mounting From Unit Base To Fuel Tank	External Isolation Mounting From Unit Base To Rigid Structure ✓
Rigid Mounting From Unit Base To Fuel Tank	Rigid Mounting From Unit Base To Rigid Structure ✓

HEADQUARTERS
113 Main Street
Bloomingdale, NJ 07403
Phone: 973.838.1780
Toll Free: 800.569.8423
Fax: 973.492.8430

CALIFORNIA
180 Promenade Circle
Suite 300
Sacramento, CA 95834
Phone: 916.634.7771

TEXAS
11930 Brittmoore Park Drive
Houston, TX 77041
Phone: 713.466.0003
Fax: 713.466.1355

thevmcgroup.com





VMC GROUP
THE POWER OF TOGETHER™



CERTIFICATE OF COMPLIANCE

SEISMIC DESIGN OF NONSTRUCTURAL COMPONENTS AND SYSTEMS

Certified Product Table:

Series	Model	Max Rating [kW]	Length [in]	Width [in]	Height [in]	S _{DS} @ z/h=0	S _{DS} @ z/h=1	Tank Range [gal]	Enclosure ¹	Mounting Configurations
DFEx (QSX15)	J, K	450, 500	366	86	128	1.94	0.64	270-2525	F183, F200-F205	Rigid Mounting From Unit Base To Rigid Structure / Fuel Tank External Isolation Mounting From Unit Base to Rigid Structure/Fuel Tank
DQDAx (QSL9-G7)	A, B, C	250, 275, 300	266	90	134	2.48	2.00	270-2050		
DQHAx (QSM11)	A, B	275, 300	226	80	128	2.28	2.28	270-1700		
DSHAx (QSL9-G2)	D	230	143	42	110		2.00	282-1296	F172-173, F182, F216-217	
DSGAx (QSB7)	A, B, C, D, E	100, 125, 150, 175, 200	184	44	114	2.48		309-1140	F173, F182, F216-217, F232-233	Rigid Mounting From Unit Base To Rigid Structure / Fuel Tank

¹Note: The F201, F202, F204, & F205 are certified in the tested mineral wool foam configuration, as well as the analyzed PU foam configuration highlighted in the FEA section of Certification Report VMA-50957-01

Group	Type	S _{DS} (z/h=0)	S _{DS} (z/h=1)	A _{Flex-H}	A _{Rig-H}	A _{Flex-V}	A _{Rig-V}	Rigid Mounting F _p /W _p	Isolated Mounting F _p /W _p
Seismic	AC156	1.940	0.647	1.94	0.776	1.293	0.518	0.873	1.455

This certification includes the open generator set and the enclosed generator set when installed with or without the sub-base tank. The generator set and included options shall be a catalogue design and factory supplied. The generator set and applicable options shall be installed and attached to the building structure per the manufacturer supplied seismic installation instructions. This certification excludes After Treatment Units (ATUs), all non-factory supplied accessories, including but not limited to mufflers, isolation/restraint devices, remote control panels, remote radiators, pumps and other electrical/mechanical components.



VMA-50957-01C (Revision 12)
Issue Date: Thursday, March 2, 2017
Revision Date: Tuesday, May 2, 2023
Expiration Date: Tuesday, June 30, 2026



VMC GROUP
THE POWER OF TOGETHER™



CERTIFICATE OF COMPLIANCE

SEISMIC DESIGN OF NONSTRUCTURAL COMPONENTS AND SYSTEMS

Notes & Comments:

1. All equipment listed herein successfully passed the seismic acceptance criteria for shake testing non-structural components and systems as set forth in the ICC AC-156. The Test Response Spectrum (TRS) enveloped the Required Response Spectrum (RRS) for all units tested. The tested units were representative sample(s) of a contingent of models and all remained captive and structurally sound after the seismic shake simulation. The units also remained functionally operational after the simulation testing as functional testing was completed by the equipment manufacturer before and after the seismic simulations. Although a seismic qualified unit inherently contains some wind resisting capacity, that capacity is undetermined and is excluded from this certification. Snow/Ice loads have been neglected and thus limit the unit to be installed both indoors (covered by an independent protective structure) and out of doors (exposed to accumulating snow/ice) for ground snow loads no greater than 30 psf for all applications.
2. The following building codes are addressed under this certification:
 - IBC 2015 referencing ASCE7-10 and ICC-ES AC-156
 - IBC 2012 referencing ASCE7-10 and ICC-ES AC-156
 - IBC 2009 referencing ASCE7-05 and ICC-ES AC-156
 - IBC 2006 referencing ASCE7-05 and ICC-ES AC-156
3. Refer to the manufacturer supplied installation drawings for anchor requirements and mounting considerations for seismic applications. Required anchor locations, size, style, and load capacities (tension and shear) may be specified on the installation drawings or specified by a 3rd party. Mounting requirement details such as anchor brand, type, embedment depth, edge spacing, anchor-to-anchor spacing, concrete strength, special inspection, wall design, and attachment to non-building structures must be outlined and approved by the Engineer of Record for the project or building. Structural walls, structural floors, and housekeeping pads must also be seismically designed and approved by the project or building Structural Engineer of Record to withstand the seismic anchor loads as defined on the installation drawings. The installing contractor is responsible for ensuring the proper installation of all anchors and mounting hardware.
4. For this certificate and certification to remain valid, this certificate must correspond to the "Seismic Certification Label" found affixed to the unit by the factory. The label ensures the manufacturer built the unit in conformance to the IBC seismic design criteria set forth by the Certified Seismic Qualification Agency, the VMC Group, and meets the seismic design levels claimed by this certificate.
5. Mechanical, Electrical, and Plumbing connections to the equipment must be flexibly attached as to not transfer load through the connection. The structural integrity of any conduit, cable trays, piping, ductwork and/or flexible connections is the responsibility of others. This certification makes no statements of compliance in regards to NEMA, IP, UL, CSA, or other relevant standards after a seismic event. For compliance to other relevant standards, please contact the manufacturer.
6. This certificate applies to units manufactured at:
 - Cummins Power Generation, Inc., 1400 73rd Ave NE, Minneapolis, MN 55432
7. This certification follows the VMC Group's ISO-17065 Scheme.
8. The certified seismic installation methods states are a summary for all series this certificate covers, for more detailed information on the certified seismic installation methods, see the certified product tables.

John P. Giuliano, PE
President, VMC Group



VMA-50957-01C (Revision 12)
Issue Date: Thursday, March 2, 2017
Revision Date: Tuesday, May 2, 2023
Expiration Date: Tuesday, June 30, 2026





Section 3

Generator Drawings

PROENGINEER

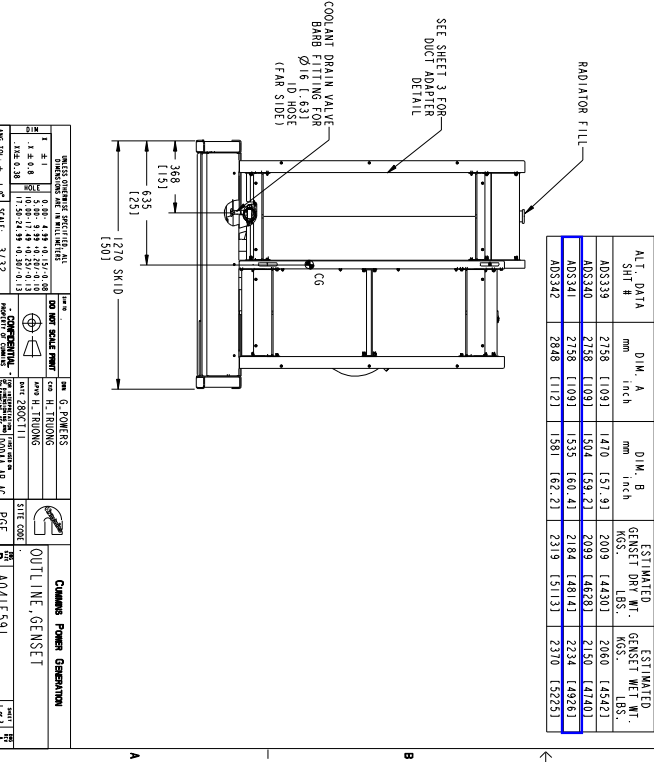
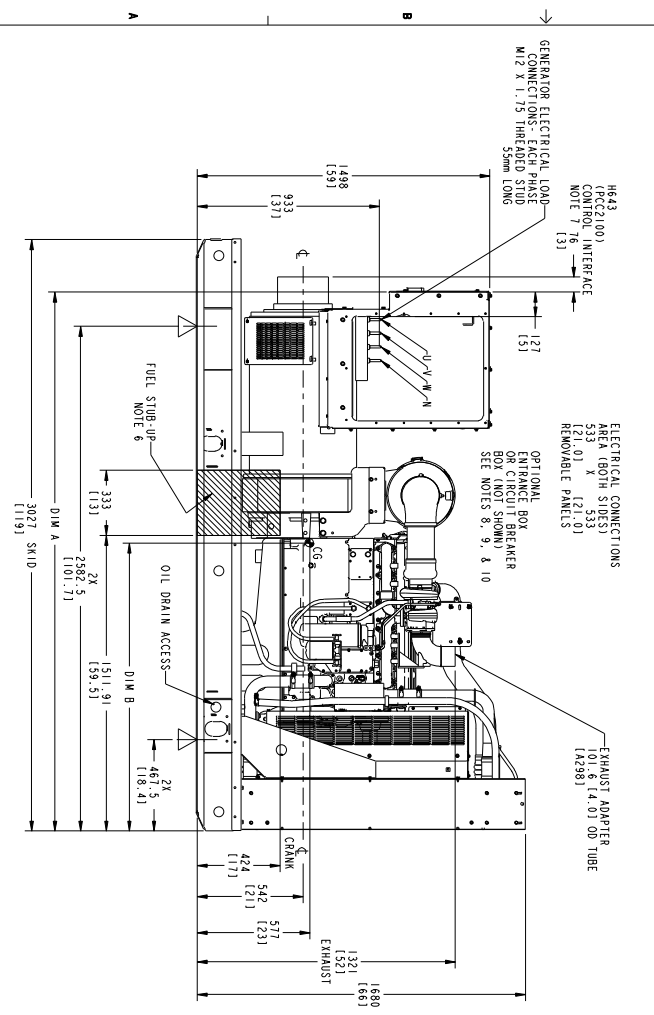
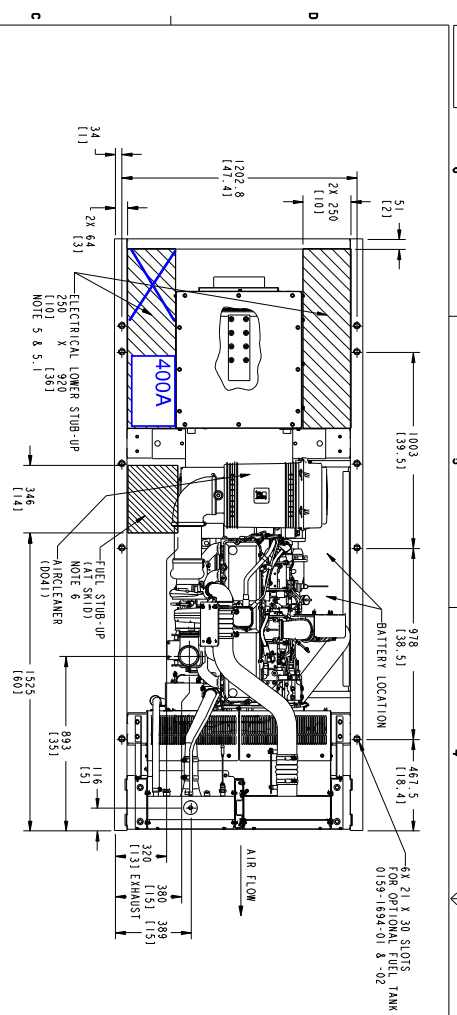

NOTES:

- DIMENSIONS SHOWN IN () ARE INCH.
- 23 X 30 SLOTS MARKED BY ∇ FOR 4 POINT ISOLATION MOUNTING OR SECURING TO MOUNTING SURFACE.
- GENSET SUPPLIED WITH FLEXIBLE FUEL LINES THAT CAN BE CONNECTED TO GENERATOR SET INTERFACE POINTS.
- FUEL SUPPLY LINE: 1525 (60) LONG WITH 1/2-14 NPT (MALE) TERMINATIONS.
- FUEL RETURN LINE: 1780 (70) LONG WITH 3/8-18 NPT (MALE) TERMINATIONS.
- TABULATED WEIGHT AND CG IS FOR GENERATOR SET WITH NO OPTIONS.
- REFER TO CIRCUIT BREAKER OUTLINE DRAWING FOR ELECTRICAL STUB-UP AREA FOR SPECIFIC BREAKERS.
- REFER TO SUBBASE FUEL TANK OUTLINE DRAWING FOR ELECTRICAL STUB-UP AREA AVAILABLE WITH FUEL TANKS.
- FUEL STUB-UP AREA IS NOT AVAILABLE WITH SUBBASE FUEL TANK.
- CONTROL INTERFACE CONNECTIONS SHOULD BE MADE WITH FLEXIBLE CONDUIT.
- FOR ENTRANCE BOX APPLICATIONS SEE APPLICABLE ENTRANCE BOX OUTLINE DRAWING.
- OPTIONAL ENTRANCE BOX (NOT SHOWN) WILL BE MOUNTED ON THE RIGHT SIDE AS VIEWED FROM THE CONTROL.
- OPTIONAL BREAKER BOX (NOT SHOWN) WILL BE MOUNTED ON THE LEFT SIDE AS VIEWED FROM THE CONTROL UNLESS OTHERWISE SPECIFIED.

ALT. DATA	DIM. A		DIM. B		ESTIMATED			
	mm	inch	mm	inch	GENSET GRV WT. LBS.	ESTIMATED GENSET WT. LBS.		
AD5339	2758	(109)	1470	(57.9)	2009	(4430)	2060	(4542)
AD5340	2758	(109)	1504	(59.2)	2099	(4628)	2150	(4740)
AD5341	2758	(109)	1535	(60.4)	2184	(4814)	2234	(4926)
AD5342	2848	(112)	1581	(62.2)	2319	(5113)	2310	(5025)

PRODUCTION MATERIAL		DIMENSIONS		WEIGHTS	
1	3	0.38	0.015	0.38	0.015
2	4	0.38	0.015	0.38	0.015
3	5	0.38	0.015	0.38	0.015
4	6	0.38	0.015	0.38	0.015
5	7	0.38	0.015	0.38	0.015
6	8	0.38	0.015	0.38	0.015
7	9	0.38	0.015	0.38	0.015
8	10	0.38	0.015	0.38	0.015
9	11	0.38	0.015	0.38	0.015
10	12	0.38	0.015	0.38	0.015
11	13	0.38	0.015	0.38	0.015
12	14	0.38	0.015	0.38	0.015
13	15	0.38	0.015	0.38	0.015
14	16	0.38	0.015	0.38	0.015
15	17	0.38	0.015	0.38	0.015
16	18	0.38	0.015	0.38	0.015
17	19	0.38	0.015	0.38	0.015
18	20	0.38	0.015	0.38	0.015
19	21	0.38	0.015	0.38	0.015
20	22	0.38	0.015	0.38	0.015
21	23	0.38	0.015	0.38	0.015
22	24	0.38	0.015	0.38	0.015
23	25	0.38	0.015	0.38	0.015
24	26	0.38	0.015	0.38	0.015
25	27	0.38	0.015	0.38	0.015
26	28	0.38	0.015	0.38	0.015
27	29	0.38	0.015	0.38	0.015
28	30	0.38	0.015	0.38	0.015
29	31	0.38	0.015	0.38	0.015
30	32	0.38	0.015	0.38	0.015
31	33	0.38	0.015	0.38	0.015
32	34	0.38	0.015	0.38	0.015
33	35	0.38	0.015	0.38	0.015
34	36	0.38	0.015	0.38	0.015
35	37	0.38	0.015	0.38	0.015
36	38	0.38	0.015	0.38	0.015
37	39	0.38	0.015	0.38	0.015
38	40	0.38	0.015	0.38	0.015
39	41	0.38	0.015	0.38	0.015
40	42	0.38	0.015	0.38	0.015
41	43	0.38	0.015	0.38	0.015
42	44	0.38	0.015	0.38	0.015
43	45	0.38	0.015	0.38	0.015
44	46	0.38	0.015	0.38	0.015
45	47	0.38	0.015	0.38	0.015
46	48	0.38	0.015	0.38	0.015
47	49	0.38	0.015	0.38	0.015
48	50	0.38	0.015	0.38	0.015
49	51	0.38	0.015	0.38	0.015
50	52	0.38	0.015	0.38	0.015
51	53	0.38	0.015	0.38	0.015
52	54	0.38	0.015	0.38	0.015
53	55	0.38	0.015	0.38	0.015
54	56	0.38	0.015	0.38	0.015
55	57	0.38	0.015	0.38	0.015
56	58	0.38	0.015	0.38	0.015
57	59	0.38	0.015	0.38	0.015
58	60	0.38	0.015	0.38	0.015
59	61	0.38	0.015	0.38	0.015
60	62	0.38	0.015	0.38	0.015
61	63	0.38	0.015	0.38	0.015
62	64	0.38	0.015	0.38	0.015
63	65	0.38	0.015	0.38	0.015
64	66	0.38	0.015	0.38	0.015
65	67	0.38	0.015	0.38	0.015
66	68	0.38	0.015	0.38	0.015
67	69	0.38	0.015	0.38	0.015
68	70	0.38	0.015	0.38	0.015
69	71	0.38	0.015	0.38	0.015
70	72	0.38	0.015	0.38	0.015
71	73	0.38	0.015	0.38	0.015
72	74	0.38	0.015	0.38	0.015
73	75	0.38	0.015	0.38	0.015
74	76	0.38	0.015	0.38	0.015
75	77	0.38	0.015	0.38	0.015
76	78	0.38	0.015	0.38	0.015
77	79	0.38	0.015	0.38	0.015
78	80	0.38	0.015	0.38	0.015
79	81	0.38	0.015	0.38	0.015
80	82	0.38	0.015	0.38	0.015
81	83	0.38	0.015	0.38	0.015
82	84	0.38	0.015	0.38	0.015
83	85	0.38	0.015	0.38	0.015
84	86	0.38	0.015	0.38	0.015
85	87	0.38	0.015	0.38	0.015
86	88	0.38	0.015	0.38	0.015
87	89	0.38	0.015	0.38	0.015
88	90	0.38	0.015	0.38	0.015
89	91	0.38	0.015	0.38	0.015
90	92	0.38	0.015	0.38	0.015
91	93	0.38	0.015	0.38	0.015
92	94	0.38	0.015	0.38	0.015
93	95	0.38	0.015	0.38	0.015
94	96	0.38	0.015	0.38	0.015
95	97	0.38	0.015	0.38	0.015
96	98	0.38	0.015	0.38	0.015
97	99	0.38	0.015	0.38	0.015
98	100	0.38	0.015	0.38	0.015
99	101	0.38	0.015	0.38	0.015
100	102	0.38	0.015	0.38	0.015

PROENGINEER

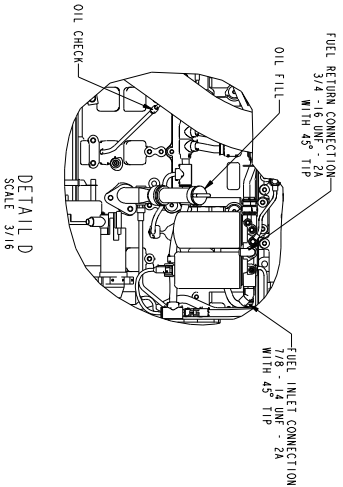
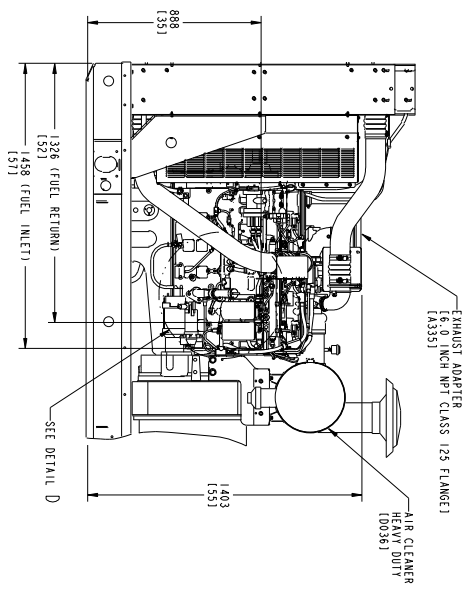
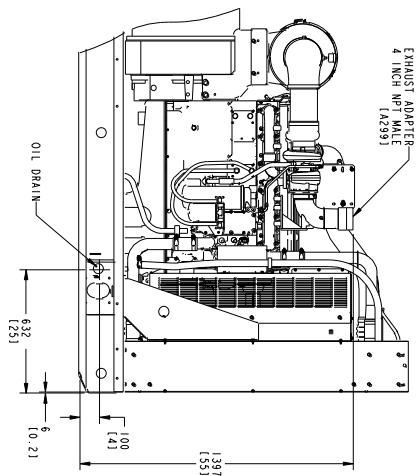
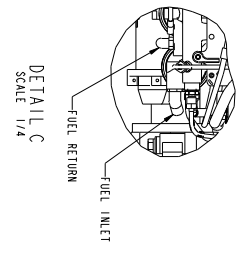
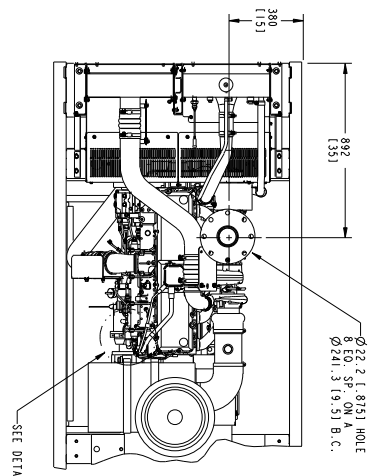
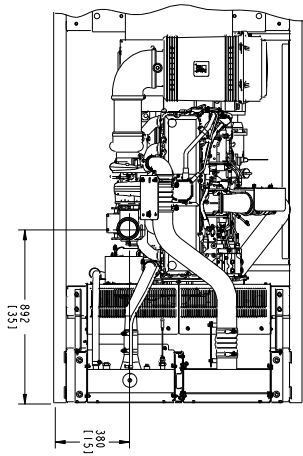

<p>PRODUCTION PART NUMBER</p> <p>1 2 3 4 5 6 7 8 9 10 11 12</p>		<p>REV. NO. 1</p> <p>DATE 01/15/01</p> <p>SCALE: 3/16</p>		<p>DESIGNED BY: J. J. PETERS</p> <p>CHECKED BY: J. J. PETERS</p> <p>DATE: 01/15/01</p>		<p>DATE: 01/15/01</p> <p>SCALE: 3/16</p>		<p>DATE: 01/15/01</p> <p>SCALE: 3/16</p>	
<p>COMPANY: CUMMINS POWER GENERATION</p> <p>ADDRESS: 1000 N. ALLEN AVENUE, P.O. BOX 100, COLUMBIANA, OH 43081</p>		<p>PROJECT: 001</p> <p>REV: 0</p>		<p>DATE: 01/15/01</p> <p>SCALE: 3/16</p>		<p>DATE: 01/15/01</p> <p>SCALE: 3/16</p>		<p>DATE: 01/15/01</p> <p>SCALE: 3/16</p>	

PROF. ENGINEER

6

5

4

3

2

1

REV. NO.	DATE	BY	REVISION	APP. ENG.	DATE
ECO-118842	A	I	PRODUCTION RELEASE		

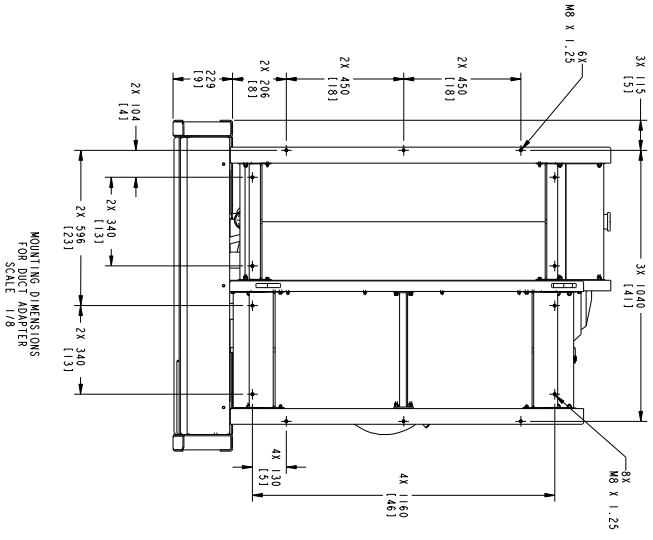

6

5

4

3

2

1

PRODUCTION DIMENSIONS DIMENSIONS ARE IN MILLIMETERS 1 = 25.4 1/8" = 3.175 1/4" = 6.35 3/8" = 9.525 1/2" = 12.7 5/8" = 15.875 3/4" = 19.05 7/8" = 22.225 1" = 25.4 1 1/8" = 29.575 1 1/4" = 33.025 1 3/8" = 36.475 1 1/2" = 38.1 1 5/8" = 41.525 1 3/4" = 44.475 1 7/8" = 47.625 2" = 50.8 2 1/8" = 54.275 2 1/4" = 57.15 2 3/8" = 60.325 2 1/2" = 63.5 2 5/8" = 66.675 2 3/4" = 69.85 2 7/8" = 73.025 3" = 76.2 3 1/8" = 79.275 3 1/4" = 82.55 3 3/8" = 85.725 3 1/2" = 89.15 3 5/8" = 92.325 3 3/4" = 95.5 3 7/8" = 98.675 4" = 101.6 4 1/8" = 104.775 4 1/4" = 108.25 4 3/8" = 111.425 4 1/2" = 114.3 4 5/8" = 117.475 4 3/4" = 120.65 4 7/8" = 123.825 5" = 127.0 5 1/8" = 130.175 5 1/4" = 133.65 5 3/8" = 136.825 5 1/2" = 140.0 5 5/8" = 143.175 5 3/4" = 146.35 5 7/8" = 149.525 6" = 152.4 6 1/8" = 155.575 6 1/4" = 159.15 6 3/8" = 162.325 6 1/2" = 165.1 6 5/8" = 168.275 6 3/4" = 171.45 6 7/8" = 174.625 7" = 177.8 7 1/8" = 180.975 7 1/4" = 184.8 7 3/8" = 187.975 7 1/2" = 191.15 7 5/8" = 194.325 7 3/4" = 197.5 7 7/8" = 200.675 8" = 203.2 8 1/8" = 206.375 8 1/4" = 210.35 8 3/8" = 213.525 8 1/2" = 216.15 8 5/8" = 219.325 8 3/4" = 222.5 8 7/8" = 225.675 9" = 228.6 9 1/8" = 231.775 9 1/4" = 235.65 9 3/8" = 238.825 9 1/2" = 241.65 9 5/8" = 244.825 9 3/4" = 248.0 9 7/8" = 251.175 10" = 254.0 10 1/8" = 257.175 10 1/4" = 261.35 10 3/8" = 264.525 10 1/2" = 268.0 10 5/8" = 271.175 10 3/4" = 274.35 10 7/8" = 277.525 11" = 281.4 11 1/8" = 284.575 11 1/4" = 288.65 11 3/8" = 291.825 11 1/2" = 295.15 11 5/8" = 298.325 11 3/4" = 301.5 11 7/8" = 304.675 12" = 309.6 12 1/8" = 312.775 12 1/4" = 316.65 12 3/8" = 319.825 12 1/2" = 323.15 12 5/8" = 326.325 12 3/4" = 329.5 12 7/8" = 332.675 13" = 336.6 13 1/8" = 339.775 13 1/4" = 343.65 13 3/8" = 346.825 13 1/2" = 350.15 13 5/8" = 353.325 13 3/4" = 356.5 13 7/8" = 359.675 14" = 364.8 14 1/8" = 367.975 14 1/4" = 371.65 14 3/8" = 374.825 14 1/2" = 378.15 14 5/8" = 381.325 14 3/4" = 384.5 14 7/8" = 387.675 15" = 391.6 15 1/8" = 394.775 15 1/4" = 398.65 15 3/8" = 401.825 15 1/2" = 405.15 15 5/8" = 408.325 15 3/4" = 411.5 15 7/8" = 414.675 16" = 420.0 16 1/8" = 423.175 16 1/4" = 427.15 16 3/8" = 430.325 16 1/2" = 433.65 16 5/8" = 436.825 16 3/4" = 440.0 16 7/8" = 443.175 17" = 447.6 17 1/8" = 450.775 17 1/4" = 454.65 17 3/8" = 457.825 17 1/2" = 461.15 17 5/8" = 464.325 17 3/4" = 467.5 17 7/8" = 470.675 18" = 476.4 18 1/8" = 479.575 18 1/4" = 483.65 18 3/8" = 486.825 18 1/2" = 490.15 18 5/8" = 493.325 18 3/4" = 496.5 18 7/8" = 499.675 19" = 505.6 19 1/8" = 508.775 19 1/4" = 512.65 19 3/8" = 515.825 19 1/2" = 519.15 19 5/8" = 522.325 19 3/4" = 525.5 19 7/8" = 528.675 20" = 533.6 20 1/8" = 536.775 20 1/4" = 540.65 20 3/8" = 543.825 20 1/2" = 547.15 20 5/8" = 550.325 20 3/4" = 553.5 20 7/8" = 556.675 21" = 561.6 21 1/8" = 564.775 21 1/4" = 568.65 21 3/8" = 571.825 21 1/2" = 575.15 21 5/8" = 578.325 21 3/4" = 581.5 21 7/8" = 584.675 22" = 591.6 22 1/8" = 594.775 22 1/4" = 598.65 22 3/8" = 601.825 22 1/2" = 605.15 22 5/8" = 608.325 22 3/4" = 611.5 22 7/8" = 614.675 23" = 620.4 23 1/8" = 623.575 23 1/4" = 627.65 23 3/8" = 630.825 23 1/2" = 634.15 23 5/8" = 637.325 23 3/4" = 640.5 23 7/8" = 643.675 24" = 651.6 24 1/8" = 654.775 24 1/4" = 658.65 24 3/8" = 661.825 24 1/2" = 665.15 24 5/8" = 668.325 24 3/4" = 671.5 24 7/8" = 674.675 25" = 684.8 25 1/8" = 687.975 25 1/4" = 691.65 25 3/8" = 694.825 25 1/2" = 698.15 25 5/8" = 701.325 25 3/4" = 704.5 25 7/8" = 707.675 26" = 717.6 26 1/8" = 720.775 26 1/4" = 724.65 26 3/8" = 727.825 26 1/2" = 731.15 26 5/8" = 734.325 26 3/4" = 737.5 26 7/8" = 740.675 27" = 751.6 27 1/8" = 754.775 27 1/4" = 758.65 27 3/8" = 761.825 27 1/2" = 765.15 27 5/8" = 768.325 27 3/4" = 771.5 27 7/8" = 774.675 28" = 784.8 28 1/8" = 787.975 28 1/4" = 791.65 28 3/8" = 794.825 28 1/2" = 798.15 28 5/8" = 801.325 28 3/4" = 804.5 28 7/8" = 807.675 29" = 817.6 29 1/8" = 820.775 29 1/4" = 824.65 29 3/8" = 827.825 29 1/2" = 831.15 29 5/8" = 834.325 29 3/4" = 837.5 29 7/8" = 840.675 30" = 851.6 30 1/8" = 854.775 30 1/4" = 858.65 30 3/8" = 861.825 30 1/2" = 865.15 30 5/8" = 868.325 30 3/4" = 871.5 30 7/8" = 874.675 31" = 884.8 31 1/8" = 887.975 31 1/4" = 891.65 31 3/8" = 894.825 31 1/2" = 898.15 31 5/8" = 901.325 31 3/4" = 904.5 31 7/8" = 907.675 32" = 917.6 32 1/8" = 920.775 32 1/4" = 924.65 32 3/8" = 927.825 32 1/2" = 931.15 32 5/8" = 934.325 32 3/4" = 937.5 32 7/8" = 940.675 33" = 951.6 33 1/8" = 954.775 33 1/4" = 958.65 33 3/8" = 961.825 33 1/2" = 965.15 33 5/8" = 968.325 33 3/4" = 971.5 33 7/8" = 974.675 34" = 984.8 34 1/8" = 987.975 34 1/4" = 991.65 34 3/8" = 994.825 34 1/2" = 998.15 34 5/8" = 1001.325 34 3/4" = 1004.5 34 7/8" = 1007.675 35" = 1017.6 35 1/8" = 1020.775 35 1/4" = 1024.65 35 3/8" = 1027.825 35 1/2" = 1031.15 35 5/8" = 1034.325 35 3/4" = 1037.5 35 7/8" = 1040.675 36" = 1051.6 36 1/8" = 1054.775 36 1/4" = 1058.65 36 3/8" = 1061.825 36 1/2" = 1065.15 36 5/8" = 1068.325 36 3/4" = 1071.5 36 7/8" = 1074.675 37" = 1084.8 37 1/8" = 1087.975 37 1/4" = 1091.65 37 3/8" = 1094.825 37 1/2" = 1098.15 37 5/8" = 1101.325 37 3/4" = 1104.5 37 7/8" = 1107.675 38" = 1117.6 38 1/8" = 1120.775 38 1/4" = 1124.65 38 3/8" = 1127.825 38 1/2" = 1131.15 38 5/8" = 1134.325 38 3/4" = 1137.5 38 7/8" = 1140.675 39" = 1151.6 39 1/8" = 1154.775 39 1/4" = 1158.65 39 3/8" = 1161.825 39 1/2" = 1165.15 39 5/8" = 1168.325 39 3/4" = 1171.5 39 7/8" = 1174.675 40" = 1184.8 40 1/8" = 1187.975 40 1/4" = 1191.65 40 3/8" = 1194.825 40 1/2" = 1198.15 40 5/8" = 1201.325 40 3/4" = 1204.5 40 7/8" = 1207.675 41" = 1217.6 41 1/8" = 1220.775 41 1/4" = 1224.65 41 3/8" = 1227.825 41 1/2" = 1231.15 41 5/8" = 1234.325 41 3/4" = 1237.5 41 7/8" = 1240.675 42" = 1251.6 42 1/8" = 1254.775 42 1/4" = 1258.65 42 3/8" = 1261.825 42 1/2" = 1265.15 42 5/8" = 1268.325 42 3/4" = 1271.5 42 7/8" = 1274.675 43" = 1284.8 43 1/8" = 1287.975 43 1/4" = 1291.65 43 3/8" = 1294.825 43 1/2" = 1298.15 43 5/8" = 1301.325 43 3/4" = 1304.5 43 7/8" = 1307.675 44" = 1317.6 44 1/8" = 1320.775 44 1/4" = 1324.65 44 3/8" = 1327.825 44 1/2" = 1331.15 44 5/8" = 1334.325 44 3/4" = 1337.5 44 7/8" = 1340.675 45" = 1351.6 45 1/8" = 1354.775 45 1/4" = 1358.65 45 3/8" = 1361.825 45 1/2" = 1365.15 45 5/8" = 1368.325 45 3/4" = 1371.5 45 7/8" = 1374.675 46" = 1384.8 46 1/8" = 1387.975 46 1/4" = 1391.65 46 3/8" = 1394.825 46 1/2" = 1398.15 46 5/8" = 1401.325 46 3/4" = 1404.5 46 7/8" = 1407.675 47" = 1417.6 47 1/8" = 1420.775 47 1/4" = 1424.65 47 3/8" = 1427.825 47 1/2" = 1431.15 47 5/8" = 1434.325 47 3/4" = 1437.5 47 7/8" = 1440.675 48" = 1451.6 48 1/8" = 1454.775 48 1/4" = 1458.65 48 3/8" = 1461.825 48 1/2" = 1465.15 48 5/8" = 1468.325 48 3/4" = 1471.5 48 7/8" = 1474.675 49" = 1484.8 49 1/8" = 1487.975 49 1/4" = 1491.65 49 3/8" = 1494.825 49 1/2" = 1498.15 49 5/8" = 1501.325 49 3/4" = 1504.5 49 7/8" = 1507.675 50" = 1517.6 50 1/8" = 1520.775 50 1/4" = 1524.65 50 3/8" = 1527.825 50 1/2" = 1531.15 50 5/8" = 1534.325 50 3/4" = 1537.5 50 7/8" = 1540.675 51" = 1551.6 51 1/8" = 1554.775 51 1/4" = 1558.65 51 3/8" = 1561.825 51 1/2" = 1565.15 51 5/8" = 1568.325 51 3/4" = 1571.5 51 7/8" = 1574.675 52" = 1584.8 52 1/8" = 1587.975 52 1/4" = 1591.65 52 3/8" = 1594.825 52 1/2" = 1598.15 52 5/8" = 1601.325 52 3/4" = 1604.5 52 7/8" = 1607.675 53" = 1617.6 53 1/8" = 1620.775 53 1/4" = 1624.65 53 3/8" = 1627.825 53 1/2" = 1631.15 53 5/8" = 1634.325 53 3/4" = 1637.5 53 7/8" = 1640.675 54" = 1651.6 54 1/8" = 1654.775 54 1/4" = 1658.65 54 3/8" = 1661.825 54 1/2" = 1665.15 54 5/8" = 1668.325 54 3/4" = 1671.5 54 7/8" = 1674.675 55" = 1684.8 55 1/8" = 1687.975 55 1/4" = 1691.65 55 3/8" = 1694.825 55 1/2" = 1698.15 55 5/8" = 1701.325 55 3/4" = 1704.5 55 7/8" = 1707.675 56" = 1717.6 56 1/8" = 1720.775 56 1/4" = 1724.65 56 3/8" = 1727.825 56 1/2" = 1731.15 56 5/8" = 1734.325 56 3/4" = 1737.5 56 7/8" = 1740.675 57" = 1751.6 57 1/8" = 1754.775 57 1/4" = 1758.65 57 3/8" = 1761.825 57 1/2" = 1765.15 57 5/8" = 1768.325 57 3/4" = 1771.5 57 7/8" = 1774.675 58" = 1784.8 58 1/8" = 1787.975 58 1/4" = 1791.65 58 3/8" = 1794.825 58 1/2" = 1798.15 58 5/8" = 1801.325 58 3/4" = 1804.5 58 7/8" = 1807.675 59" = 1817.6 59 1/8" = 1820.775 59 1/4" = 1824.65 59 3/8" = 1827.825 59 1/2" = 1831.15 59 5/8" = 1834.325 59 3/4" = 1837.5 59 7/8" = 1840.675 60" = 1851.6 60 1/8" = 1854.775 60 1/4" = 1858.65 60 3/8" = 1861.825 60 1/2" = 1865.15 60 5/8" = 1868.325 60 3/4" = 1871.5 60 7/8" = 1874.675 61" = 1884.8 61 1/8" = 1887.975 61 1/4" = 1891.65 61 3/8" = 1894.825 61 1/2" = 1898.15 61 5/8" = 1901.325 61 3/4" = 1904.5 61 7/8" = 1907.675 62" = 1917.6 62 1/8" = 1920.775 62 1/4" = 1924.65 62 3/8" = 1927.825 62 1/2" = 1931.15 62 5/8" = 1934.325 62 3/4" = 1937.5 62 7/8" = 1940.675 63" = 1951.6 63 1/8" = 1954.775 63 1/4" = 1958.65 63 3/8" = 1961.825 63 1/2" = 1965.15 63 5/8" = 1968.325 63 3/4" = 1971.5 63 7/8" = 1974.675 64" = 1984.8 64 1/8" = 1987.975 64 1/4" = 1991.65 64 3/8" = 1994.825 64 1/2" = 1998.15 64 5/8" = 2001.325 64 3/4" = 2004.5 64 7/8" = 2007.675 65" = 2017.6 65 1/8" = 2020.775 65 1/4" = 2024.65 65 3/8" = 2027.825 65 1/2" = 2031.15 65 5/8" = 2034.325 65 3/4" = 2037.5 65 7/8" = 2040.675 66" = 2051.6 66 1/8" = 2054.775 66 1/4" = 2058.65 66 3/8" = 2061.825 66 1/2" = 2065.15 66 5/8" = 2068.325 66 3/4" = 2071.5 66 7/8" = 2074.675 67" = 2084.8 67 1/8" = 2087.975 67 1/4" = 2091.65 67 3/8" = 2094.825 67 1/2" = 2098.15 67 5/8" = 2101.325 67 3/4" = 2104.5 67 7/8" = 2107.675 68" = 2117.6 68 1/8" = 2120.775 68 1/4" = 2124.65 68 3/8" = 2127.825 68 1/2" = 2131.15 68 5/8" = 2134.325 68 3/4" = 2137.5 68 7/8" = 2140.675 69" = 2151.6 69 1/8" = 2154.775 69 1/4" = 2158.65 69 3/8" = 2161.825 69 1/2" = 2165.15 69 5/8" = 2168.325 69 3/4" = 2171.5 69 7/8" = 2174.675 70" = 2184.8 70 1/8" = 2187.975 70 1/4" = 2191.65 70 3/8" = 2194.825 70 1/2" = 21	
---	--

QSL9 G7 WIRING DIAGRAM WITH PCC2300 AND CM2850

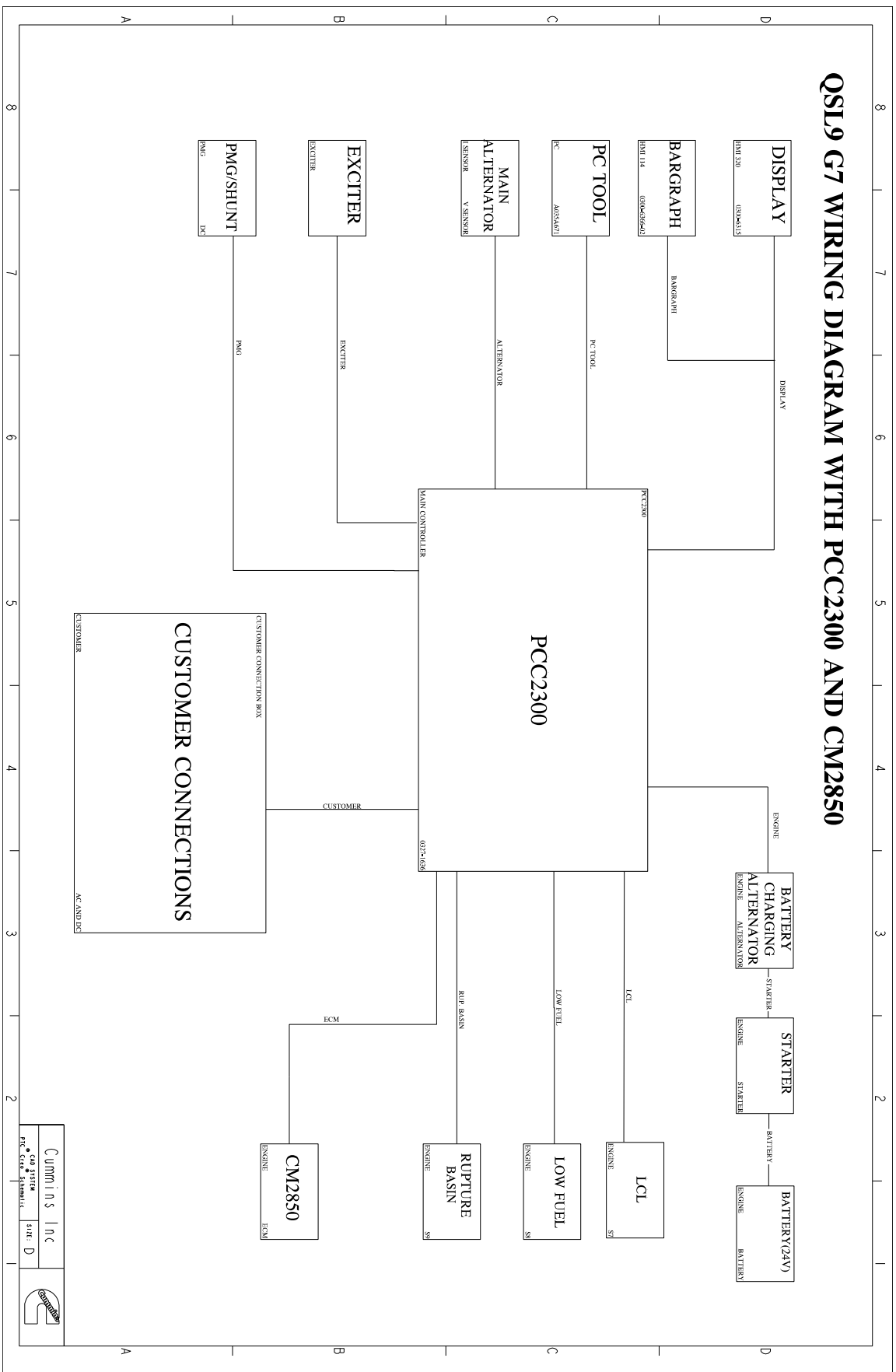

Cummins Data Classification: **Cummins Confidential**
 This document (and the information shown thereon) is **Confidential and Proprietary** and shall not be disclosed to others in hard copy or electronic form, reproduced by any means, or used for any purpose without written consent of Cummins Inc.

Part Number: **A065N785** Part Revision: **A**
 Part Name: **DIAGRAM, WIRING**
 Drawing Category: **Detail** State: **Released** Sheet 1 of 8

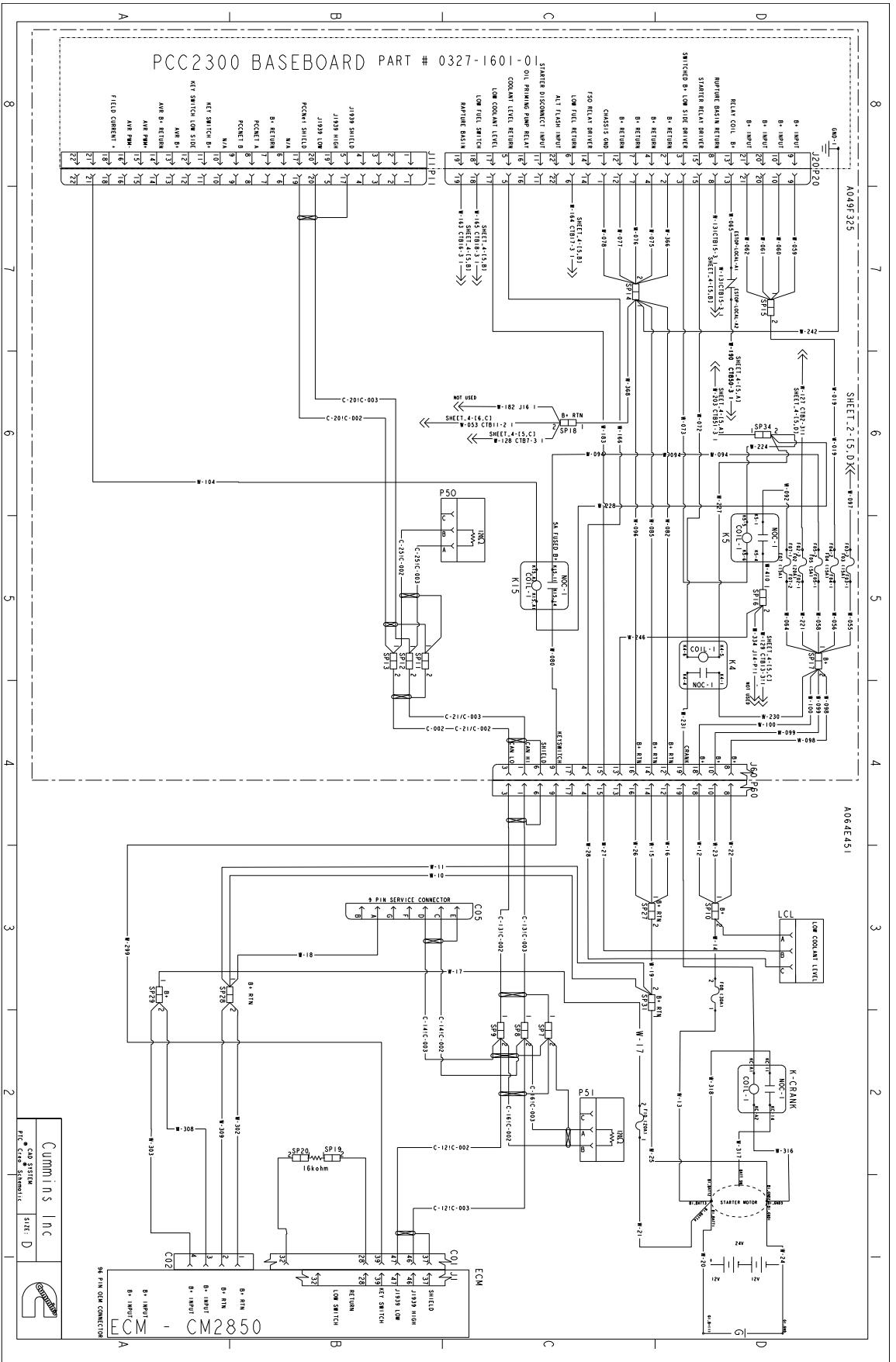

Cummins Data Classification: **Cummins Confidential**

This document (and the information shown thereon) is **Confidential and Proprietary** and shall not be disclosed to others in hard copy or electronic form, reproduced by any means, or used for any purpose without written consent of Cummins Inc.

Part Number: **A065N785** Part Revision: **A**
 Part Name: **DIAGRAM, WIRING**
 Drawing Category: **Detail State: Released** Sheet 3 of 8

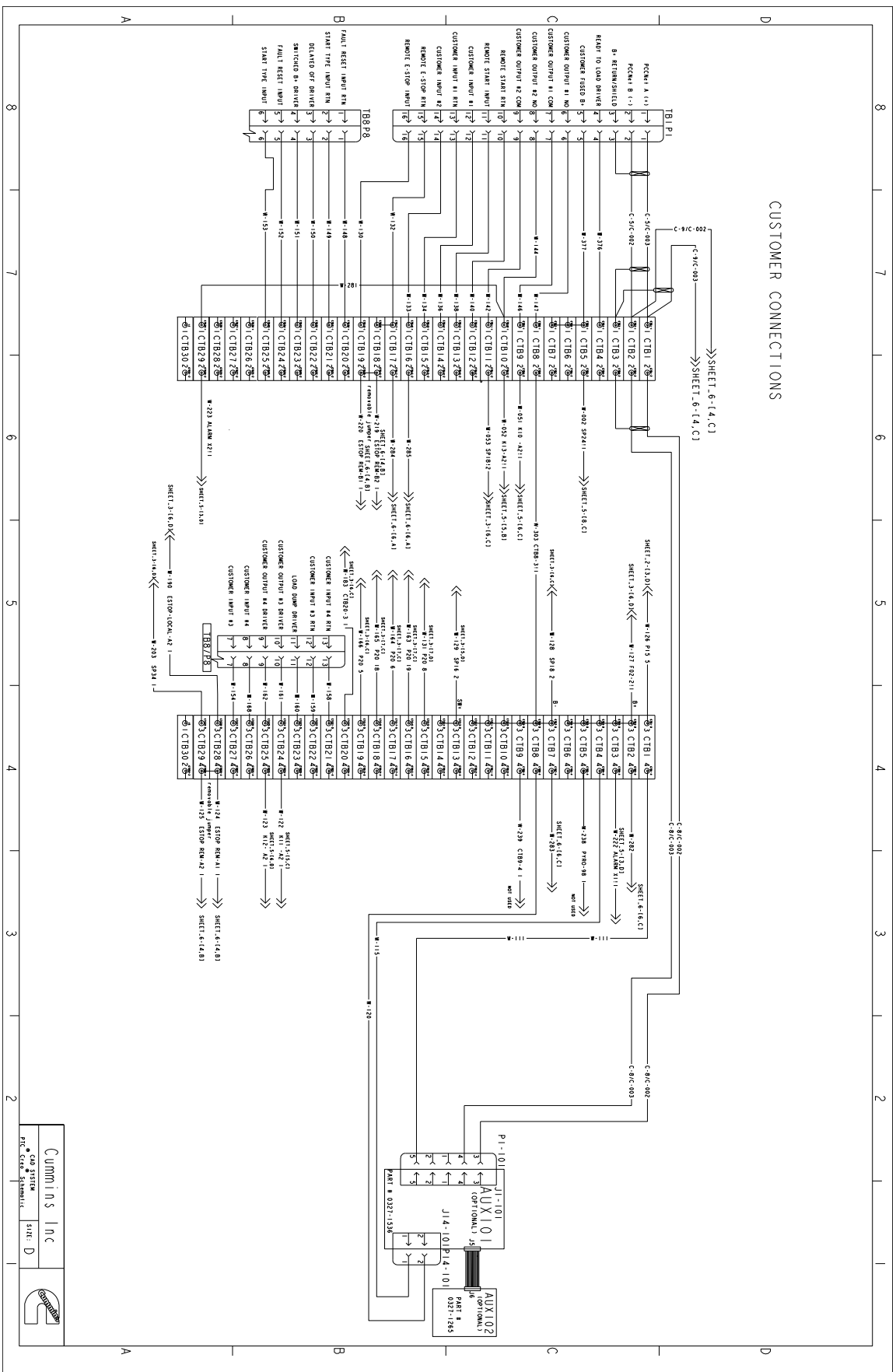

Cummins Data Classification:
Cummins Confidential

This document (and the information shown thereon) is
Confidential and Proprietary and shall not be disclosed to others
 in hard copy or electronic form, reproduced by any means, or used
 for any purpose without written consent of Cummins Inc.

Part Number: **A065N785** Part Revision: **A**
 Part Name: **DIAGRAM, WIRING**
 Drawing Category: **Detail** State: **Released** Sheet 4 of 8

Cummins Inc.		
REV. 000	DATE: D	

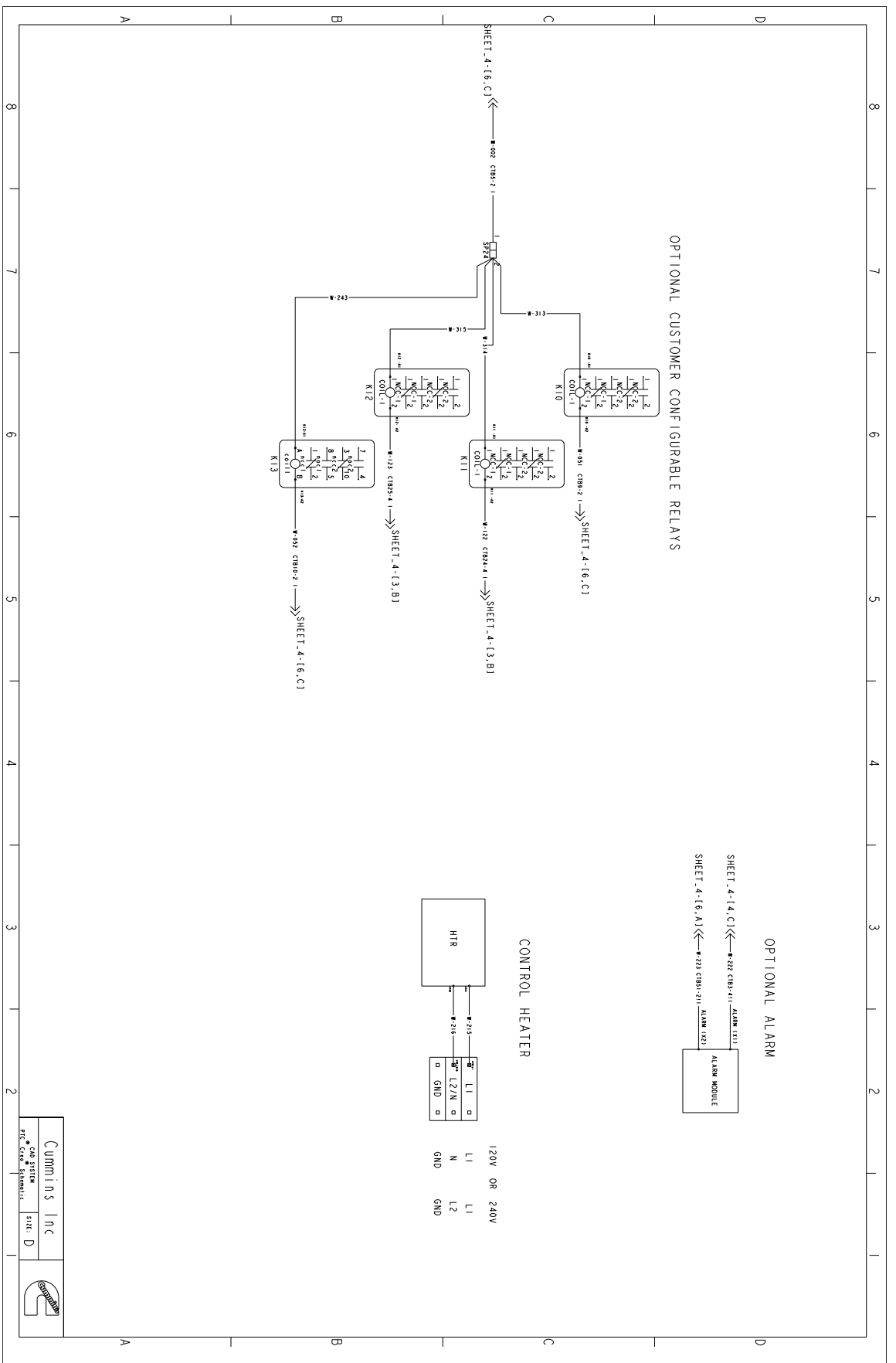

Cummins Data Classification:
Cummins Confidential

This document (and the information shown thereon) is
Confidential and Proprietary and shall not be disclosed to others
 in hard copy or electronic form, reproduced by any means, or used
 for any purpose without written consent of Cummins Inc.

Part Number: **A065N785** Part Revision: **A**
 Part Name: **DIAGRAM, WIRING**
 Drawing Category: **Detail** State: **Released** Sheet 5 of 8

Cummins Inc.		
CUMMINS INC. 1950 EAST WISCONSIN AVE. COLUMBIANA, MS 38916	DATE: D	

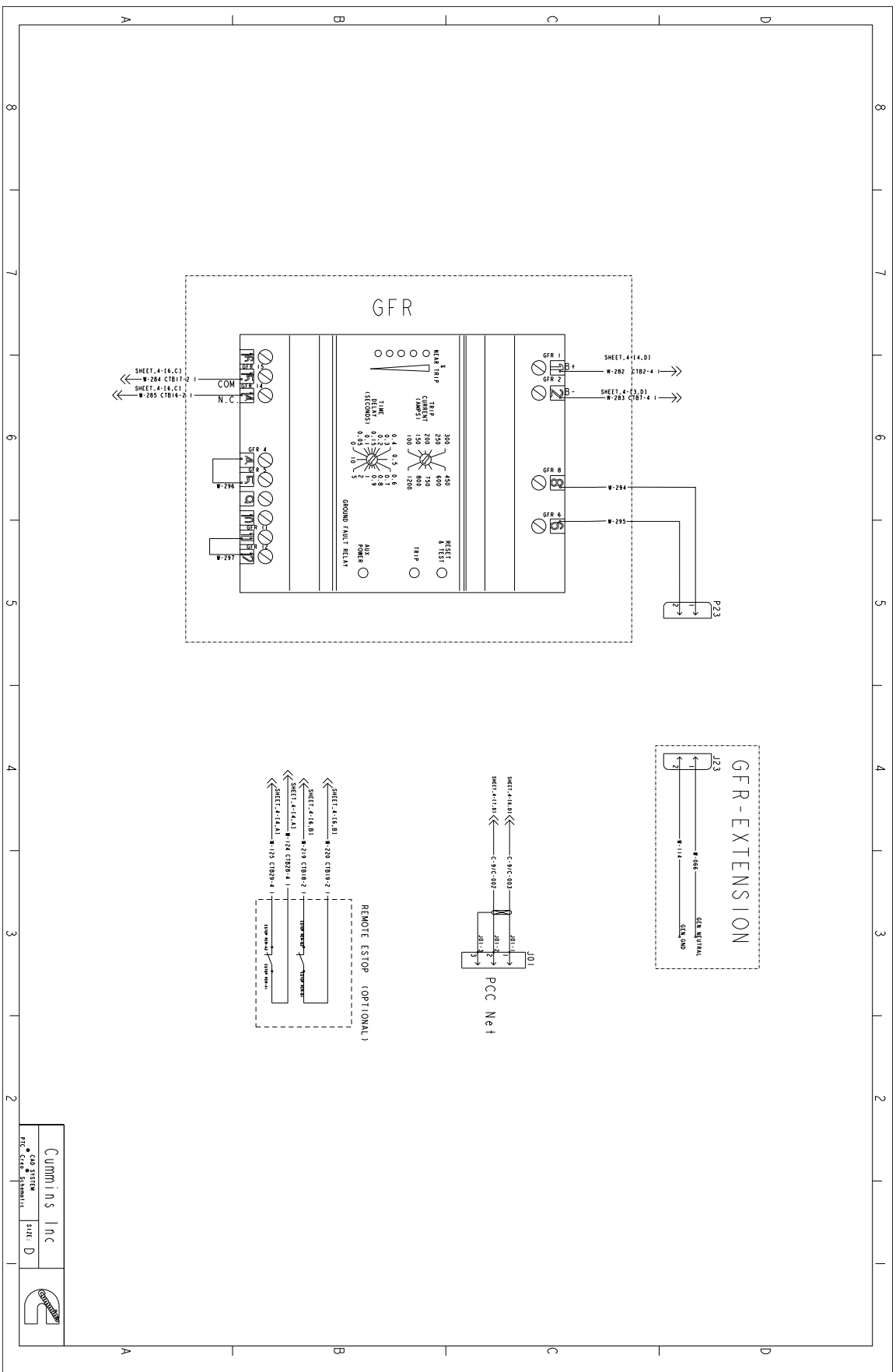

Cummins Data Classification: **Confidential and Proprietary**
 This document (and the information shown thereon) is **Confidential and Proprietary** and shall not be disclosed to others in hard copy or electronic form, reproduced by any means, or used for any purpose without written consent of Cummins Inc.

Part Number: **A065N785** Part Revision: **A**
 Part Name: **DIAGRAM, WIRING**
 Drawing Category: **Detail** State: **Released** Sheet 6 of 8

Cummins Inc		
Part Number: A065N785	State: D	

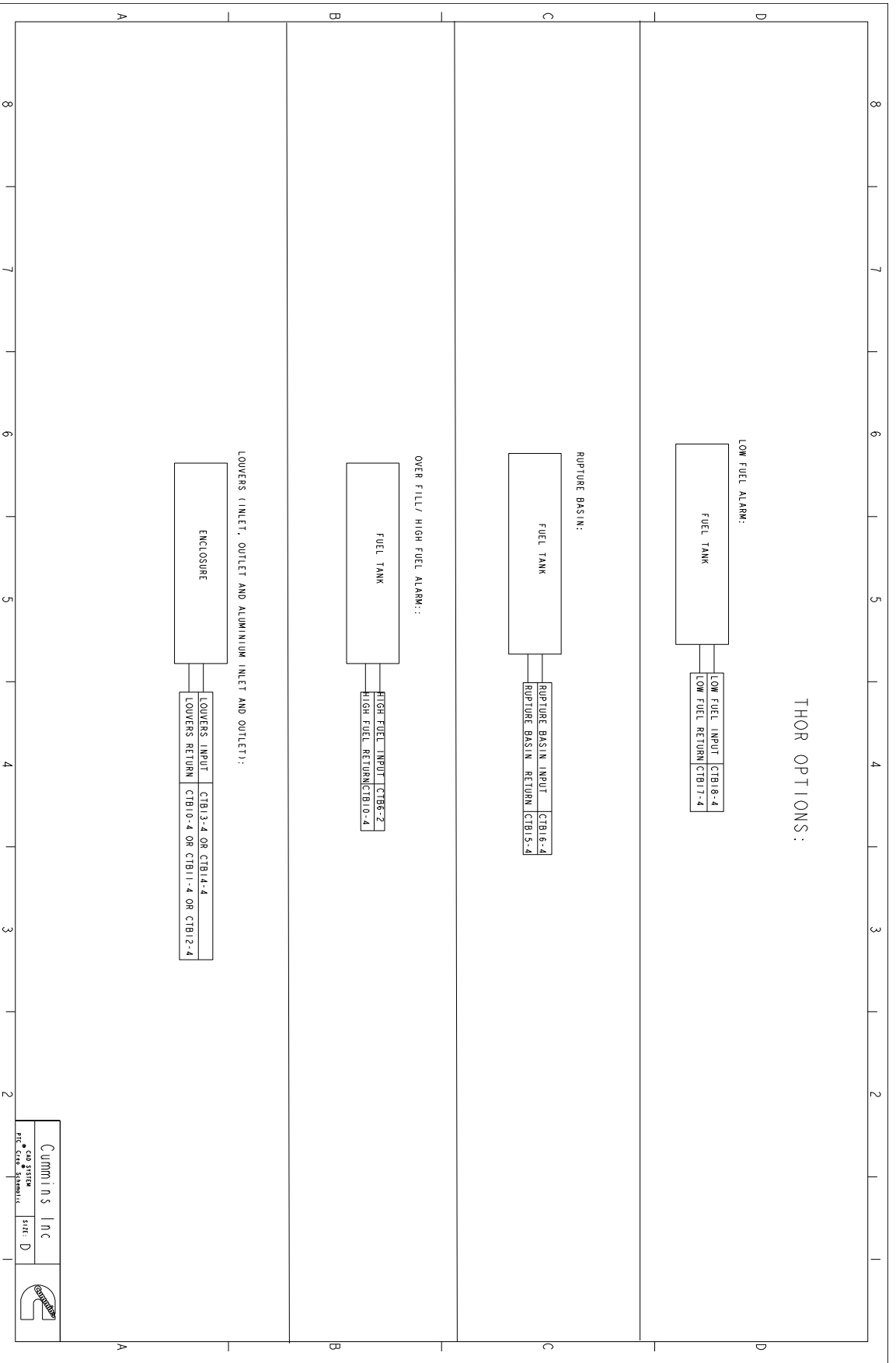

Cummins Data Classification:
Cummins Confidential

This document (and the information shown thereon) is **Confidential and Proprietary** and shall not be disclosed to others in hard copy or electronic form, reproduced by any means, or used for any purpose without written consent of Cummins Inc.

Part Number: **A065N785** Part Revision: **A**
 Part Name: **DIAGRAM, WIRING**
 Drawing Category: **Detail** State: **Released** Sheet 7 of 8

TANK/LIFT BASE FEATURE CODE	TANK CAPACITY	TANK WEIGHT (WT. KG. (LBS.))	DIM. D	DIM. E	DIM. F	DIM. H	DIM. I	DIM. J	DIM. K
C202	300	1060 (2338)	743 (190)	183 (47.2)	305 (77.2)	528 (134.2)	1176 (298.2)	614.7 (156.2)	668 (169.2)
C203	500	1171 (2584)	743 (190)	284 (72.2)	358 (91.4)	571 (145.2)	1177 (298.2)	614.7 (156.2)	668 (169.2)
C204	600	1253 (2785)	743 (190)	361 (92.2)	408 (104.2)	627 (160.2)	1228 (313.2)	614.7 (156.2)	668 (169.2)
C205	660	1295 (2857)	743 (190)	389 (99.2)	521 (133.2)	742 (189.2)	1343 (341.2)	614.7 (156.2)	668 (169.2)
C206	720	1275 (2814)	743 (190)	427 (109.2)	559 (142.2)	780 (199.2)	1381 (350.2)	614.7 (156.2)	668 (169.2)
C207	850	1445 (3189)	743 (190)	487 (124.2)	640 (164.2)	881 (225.2)	1481 (376.2)	614.7 (156.2)	668 (169.2)
F214	NA	2540 (5600)	81 (20.7)	203 (51.8)	424 (108.2)	1024 (261.2)	1921 (489.2)	513.3 (130.2)	513.3 (130.2)

TANK/LIFT BASE FEATURE CODE	TANK CAPACITY	DIM. G 021.9 L-FRAME	DIM. G 021.9 P-FRAME	DIM. G 021.11 P-FRAME	DIM. G 021.11 P-FRAME	DIM. G 021.15 P-FRAME	DIM. G 021.15 P-FRAME
C202	300	1451.2 (371.3)	1390.4 (355.5)	1465.3 (376.8)	1341.5 (341.5)	1701.9 (432.2)	1610.9 (414.2)
C203	500	1558.8 (401.3)	1491.2 (385.5)	1566.3 (402.8)	1448.1 (371.5)	1809.5 (462.2)	1661.7 (427.2)
C204	600	1635.8 (421.3)	1481.2 (385.5)	1561.3 (401.8)	1451.1 (371.5)	1821.7 (462.2)	1671.7 (427.2)
C205	660	1671.6 (430.3)	1525.3 (393.8)	1611.2 (414.3)	1481.1 (371.5)	1823.8 (462.2)	1671.7 (427.2)
C206	720	1711.2 (437.3)	1561.3 (401.8)	1651.2 (422.3)	1521.1 (393.8)	1823.8 (462.2)	1671.7 (427.2)
C207	850	1851.2 (472.3)	1601.3 (414.3)	1691.2 (432.3)	1561.2 (401.8)	1823.8 (462.2)	1671.7 (427.2)
F214	NA	1555.6 (401.3)	1201.8 (307.5)	1381.1 (354.8)	1285.9 (328.5)	1606.3 (412.2)	1458.5 (370.2)

NO.	REV.	DATE	BY	CHKD.	APP'D.	DESCRIPTION
1	1					ISSUED FOR REVIEW
2	1					ISSUED FOR REVIEW
3	1					ISSUED FOR REVIEW
4	1					ISSUED FOR REVIEW
5	1					ISSUED FOR REVIEW
6	1					ISSUED FOR REVIEW
7	1					ISSUED FOR REVIEW
8	1					ISSUED FOR REVIEW

OPTIONAL FEATURE F202, F205

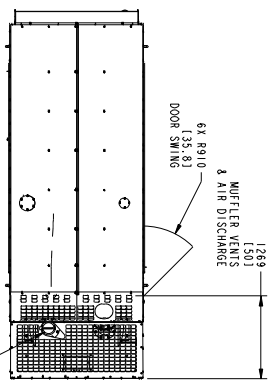

MODEL	KW	CG. DIM. "A"	CG. DIM. "B"	CG. DIM. "C"	ENCLOSURE WEIGHT KG (LBS)	ALUMINUM WEIGHT KG (LBS)
DFAB 230	2111 (83.1)	869 (34.2)	5755 (12888)	5265 (11598)		
DFAC 250	2103 (82.8)	869 (34.1)	5823 (12898)	5335 (11748)		
DOAE 275	2093 (82.4)	869 (34.2)	5914 (13098)	5424 (11948)		
DOAF 300	2085 (82.1)	871 (34.3)	6027 (13288)	5537 (12198)		
DFBF 275	2049 (80.7)	881 (34.7)	6387 (14378)	5893 (12988)		
DFCB 300	2035 (80.1)	884 (34.8)	6522 (14478)	6033 (13288)		
DFCC 350	2014 (79.3)	886 (34.9)	6635 (14628)	6145 (13358)		
DFCE 400	1999 (78.7)	889 (35.0)	6735 (14848)	6245 (13758)		
DFEG 350	1949 (78.5)	7743 (110.7)	7743 (110.7)	7253 (15982)		
DFEH 400	1876 (77.8)	734 (28.9)	7813 (17388)	7388 (16268)		
DFEJ 450	1856 (77.0)	737 (29.0)	8026 (17686)	7536 (16666)		
DFEK 500	1833 (76.1)	737 (29.0)	8162 (17986)	7672 (16966)		
DDDA 250	927 (75.9)	723 (28.5)	5957 (13098)	5467 (11998)		
DDDC 300	1845 (76.6)	724 (28.5)	6057 (13388)	5567 (12288)		
DDDA 275	1829 (82.4)	869 (34.2)	621 (13261)	578 (12738)		
DDDB 300	1821 (82.1)	871 (34.3)	634 (14016)	584 (12986)		

- NOTES:
- DIMENSIONS SHOWN IN 1 ARE INCHES.
 - FOUNDATION REFERENCE POINT (F-RP) SEE FOUNDATION DRAWING FOR DETAILS.
 - FOR FEATURE CODE L118 & L120 (FLORIDA & MICHIGAN TANKS) ADD 162.9 (6.4) TO DIM. D-J
 - SEE SHEET 2 FOR TANK VENT LOCATIONS.
 - EXCESSIVE TWISTING OF THE FUEL TANK WHEN FASTENING IT TO A FOUNDATION MAY RESULT IN STRUCTURAL FAILURE OF THE TANK. TO INSURE THE INSTALLATION DOES NOT EXCESSIVELY TWIST THE FUEL TANK, THE FOLLOWING PROCEDURE MUST BE OBSERVED:
 - REFER TO OWN APPLICATION MANUAL TO20 FOR GENERAL GENSET/TANK MOUNTING GUIDELINES.
 - (NOTE REMOVED)
 - (NOTE REMOVED)
 - (NOTE REMOVED)
 - TIGHTEN TANK HOLD DOWN MOUNTING FASTENERS.

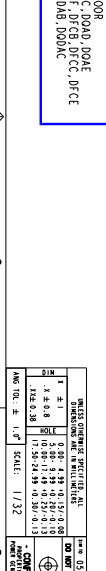
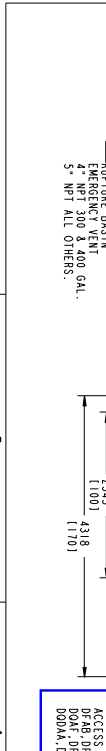
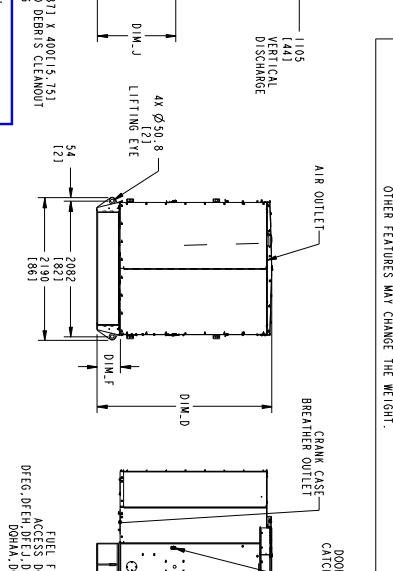
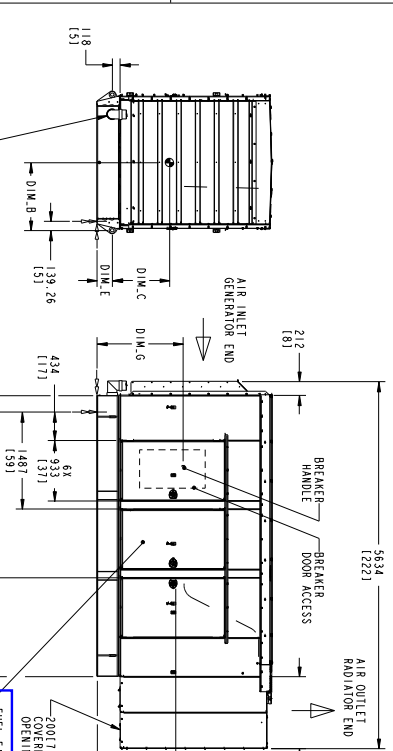

NO.	REV.	DATE	BY	CHKD.	APP'D.	DESCRIPTION
1	1					ISSUED FOR REVIEW
2	1					ISSUED FOR REVIEW
3	1					ISSUED FOR REVIEW
4	1					ISSUED FOR REVIEW
5	1					ISSUED FOR REVIEW
6	1					ISSUED FOR REVIEW
7	1					ISSUED FOR REVIEW
8	1					ISSUED FOR REVIEW

NO.	REV.	DATE	BY	CHKD.	APP'D.	DESCRIPTION
1	1					ISSUED FOR REVIEW
2	1					ISSUED FOR REVIEW
3	1					ISSUED FOR REVIEW
4	1					ISSUED FOR REVIEW
5	1					ISSUED FOR REVIEW
6	1					ISSUED FOR REVIEW
7	1					ISSUED FOR REVIEW
8	1					ISSUED FOR REVIEW

DQDAA, DQDAB, DQDAC
(C201-C207, C242, F214)

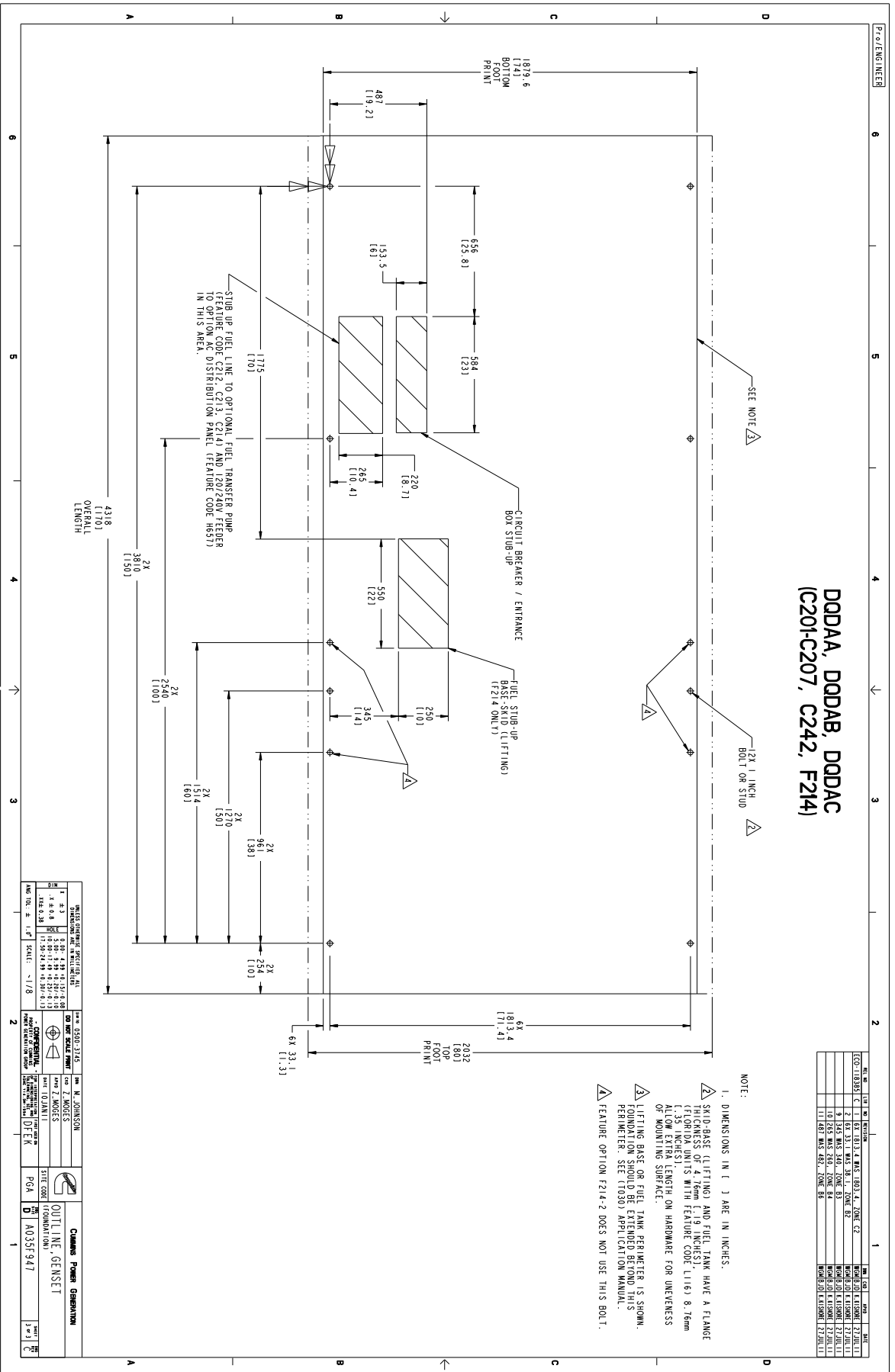

REV	NO	DESCRIPTION	DATE
1	1	ISSUE FOR CONSTRUCTION	11/18/03
2	1	ISSUE FOR CONSTRUCTION	11/18/03
3	1	ISSUE FOR CONSTRUCTION	11/18/03
4	1	ISSUE FOR CONSTRUCTION	11/18/03
5	1	ISSUE FOR CONSTRUCTION	11/18/03
6	1	ISSUE FOR CONSTRUCTION	11/18/03
7	1	ISSUE FOR CONSTRUCTION	11/18/03
8	1	ISSUE FOR CONSTRUCTION	11/18/03
9	1	ISSUE FOR CONSTRUCTION	11/18/03
10	1	ISSUE FOR CONSTRUCTION	11/18/03
11	1	ISSUE FOR CONSTRUCTION	11/18/03

- NOTE:
- 1. DIMENSIONS IN FEET ARE IN INCHES.
 - SKID-BASE (LIFTING) AND FUEL TANK HAVE A FLANGE THICKNESS OF 4.76mm (1.19 INCHES), (FLUID UNITS WITH FEATURE CODE L118) 8.76mm ALLOW EXTRA LENGTH ON HARDWARE FOR UNEVENNESS OF MOUNTING SURFACE.
 - LIFTING BASE OR FUEL TANK REPAIRER, AS SHOWN, FOUNDATION SHOULD BE EXTENDED BEYOND THIS PERIMETER. SEE (1030) APPLICATION MANUAL.
 - FEATURE OPTION F214-2 DOES NOT USE THIS BOLT.

PRODUCTION IDENTIFICATION PART NUMBER: 3142 DRAWING NUMBER: 11701 SCALE: 1/8" = 1'-0"		DESIGNER NAME: T. JOHNSON DATE: 11/18/03		CHECKER NAME: J. MOSES DATE: 11/18/03	
APPROVED FOR CONSTRUCTION NAME: T. JOHNSON DATE: 11/18/03		APPROVED FOR CONSTRUCTION NAME: J. MOSES DATE: 11/18/03		APPROVED FOR CONSTRUCTION NAME: J. MOSES DATE: 11/18/03	
CONSTRUCTION IDENTIFICATION PART NUMBER: 3142 DRAWING NUMBER: 11701 SCALE: 1/8" = 1'-0"		DESIGNER NAME: T. JOHNSON DATE: 11/18/03		CHECKER NAME: J. MOSES DATE: 11/18/03	
APPROVED FOR CONSTRUCTION NAME: T. JOHNSON DATE: 11/18/03		APPROVED FOR CONSTRUCTION NAME: J. MOSES DATE: 11/18/03		APPROVED FOR CONSTRUCTION NAME: J. MOSES DATE: 11/18/03	

CONSTRUCTION IDENTIFICATION PART NUMBER: 3142 DRAWING NUMBER: 11701 SCALE: 1/8" = 1'-0"		DESIGNER NAME: T. JOHNSON DATE: 11/18/03		CHECKER NAME: J. MOSES DATE: 11/18/03	
APPROVED FOR CONSTRUCTION NAME: T. JOHNSON DATE: 11/18/03		APPROVED FOR CONSTRUCTION NAME: J. MOSES DATE: 11/18/03		APPROVED FOR CONSTRUCTION NAME: J. MOSES DATE: 11/18/03	

SEISMIC INSTALLATIONS NOTES:

1. THE DESIGN OF POST-INSTALLED ANCHORS IN CONCRETE USED FOR THE COMPONENT ANCHORAGE IS PRE-QUALIFIED FOR SEISMIC APPLICATIONS IN ACCORDANCE WITH "ACI 308.2R" AND DOCUMENTED IN A REPORT BY A REPUTABLE TESTING AGENCY.
2. THE INSTALLATION GUIDELINES IN THIS DRAWING ARE RECOMMENDATIONS FROM THE ISOLATOR SUPPLIER AND SHOULD BE CONTACTED IF IN DOUBT.
3. ANCHORS MUST BE INSTALLED IN MINIMUM 4000 PSI COMPRESSIVE STRENGTH NORMAL WEIGHT CONCRETE EXCEPT WHERE OTHERWISE INDICATED. CONCRETE AGGREGATE MUST COMPLY WITH "ASTM C33".
4. ANCHORS MUST BE INSTALLED TO THE TORQUE SPECIFICATION AS RECOMMENDED BY THE STRUCTURAL ENGINEER OF RECORD.
5. ANCHORS MUST BE INSTALLED IN LOCATIONS SPECIFIED ON THIS INSTALLATION DRAWING.
6. WIDE WASHERS MUST BE INSTALLED AT EACH ANCHOR LOCATION BETWEEN THE ANCHOR HEAD AND EQUIPMENT FOR TENSION LOAD DISTRIBUTION. WIDE WASHERS MUST BE SERIES "W" OF AMERICAN NATIONAL STANDARD TYPE "A" PLAIN WASHERS (ANSI B18.22.1-1965, R1975) WITH THE NOMINAL WASHER SIZE SELECTED TO MATCH THE SPECIFIED NOMINAL ANCHOR DIAMETER.
7. CONCRETE FLOOR SLAB AND CONCRETE HOUSEKEEPING PADS MUST BE DESIGNED AND REBAR REINFORCED FOR SEISMIC APPLICATIONS IN ACCORDANCE WITH "ACI 318".
8. EQUIPMENT ANCHORAGE MUST BE INSTALLED PER THE MANUFACTURER'S INSTRUCTIONS.
9. ALL HOUSEKEEPING PADS MUST BE DOWELLED OR CAST INTO THE BUILDING STRUCTURAL FLOOR SLAB AND DESIGNED FOR SEISMIC APPLICATION PER "ACI 318" AND AS APPROVED BY THE STRUCTURAL ENGINEER OF RECORD.
10. ALL ACCESSORY ATTACHMENTS (PIPE, CONDUIT, ETC.) TO THE EQUIPMENT SHALL BE ATTACHED IN A MANNER THAT ALLOWS RELATIVE MOTION (FLEX, SWING, JOINT/ELEW, ETC.) TO PREVENT FAILURE DUE TO DIFFERENTIAL MOVEMENT BETWEEN THE EQUIPMENT AND ATTACHED ACCESSORY CAUSED BY SEISMIC LOADING ON THE SYSTEM.
11. FLOOR MOUNTED EQUIPMENT (WITH OR WITHOUT A HOUSEKEEPING PAD) MUST BE INSTALLED TO A REBAR REINFORCED STRUCTURAL CONCRETE FLOOR THAT IS SEISMICALLY DESIGNED AND APPROVED BY THE ENGINEER OF RECORD TO RESIST THE ADDED SEISMIC LOADS FROM COMPONENTS BEING ANCHORED TO THE FLOOR.
12. WHEN INSTALLING TO A FLOOR, REBAR INTERFERENCE MUST BE CONSIDERED.
13. ATTACHING SEISMIC CERTIFIED EQUIPMENT TO ANY FLOOR OR WALL OTHER THAN THOSE CONSTRUCTED OF STRUCTURAL CONCRETE AND DESIGNED TO ACCEPT THE SEISMIC LOADS FROM SAID EQUIPMENT IS NOT PERMITTED BY THIS SPECIFICATION AND BEYOND THE SCOPE OF THIS CERTIFICATION.
14. ATTACHING SEISMIC CERTIFIED EQUIPMENT TO ANY FLOOR CONSTRUCTED OF LIGHT WEIGHT CONCRETE OVER STEEL DECKING IS NOT PERMITTED BY THIS SPECIFICATION AND BEYOND THE SCOPE OF THIS CERTIFICATION.
15. ATTACHING SEISMIC CERTIFIED EQUIPMENT TO ANY CONCRETE BLOCK WALLS OR CINDER BLOCK WALLS IS NOT PERMITTED BY THIS SPECIFICATION AND BEYOND THE SCOPE OF THIS CERTIFICATION.
16. INSTALLATION UPON ANY STEEL DUNNAGE SHALL BE COORDINATED WITH THE STRUCTURAL ENGINEER OF RECORD. STEEL DUNNAGE MUST BE CERTIFIED BY OTHERS AS IS BEYOND THE SCOPE OF THIS REPORT.
17. INSTALLATION UPON ANY ROOFTOP CURB SHALL BE COORDINATED WITH THE CURB MANUFACTURER AND THE STRUCTURAL ENGINEER OF RECORD. ANY CURB OR CONCRETE PAD THAT SUPPORTS THE GENSET UNIT IS BEYOND THE SCOPE OF THIS CERTIFICATION.
18. NOTE REMOVED

NO.	DESCRIPTION	QTY	UNIT	DATE
1	ANCHOR BOLT 1/2"	12	EA	2/25/17
2	ANCHOR BOLT 3/4"	12	EA	2/25/17
3	ANCHOR BOLT 1"	12	EA	2/25/17
4	ANCHOR BOLT 1 1/4"	12	EA	2/25/17
5	ANCHOR BOLT 1 1/2"	12	EA	2/25/17
6	ANCHOR BOLT 1 3/4"	12	EA	2/25/17
7	ANCHOR BOLT 2"	12	EA	2/25/17
8	ANCHOR BOLT 2 1/4"	12	EA	2/25/17
9	ANCHOR BOLT 2 1/2"	12	EA	2/25/17
10	ANCHOR BOLT 2 3/4"	12	EA	2/25/17
11	ANCHOR BOLT 3"	12	EA	2/25/17
12	ANCHOR BOLT 3 1/4"	12	EA	2/25/17
13	ANCHOR BOLT 3 1/2"	12	EA	2/25/17
14	ANCHOR BOLT 3 3/4"	12	EA	2/25/17
15	ANCHOR BOLT 4"	12	EA	2/25/17
16	ANCHOR BOLT 4 1/4"	12	EA	2/25/17
17	ANCHOR BOLT 4 1/2"	12	EA	2/25/17
18	ANCHOR BOLT 4 3/4"	12	EA	2/25/17
19	ANCHOR BOLT 5"	12	EA	2/25/17
20	ANCHOR BOLT 5 1/4"	12	EA	2/25/17
21	ANCHOR BOLT 5 1/2"	12	EA	2/25/17
22	ANCHOR BOLT 5 3/4"	12	EA	2/25/17
23	ANCHOR BOLT 6"	12	EA	2/25/17
24	ANCHOR BOLT 6 1/4"	12	EA	2/25/17
25	ANCHOR BOLT 6 1/2"	12	EA	2/25/17
26	ANCHOR BOLT 6 3/4"	12	EA	2/25/17
27	ANCHOR BOLT 7"	12	EA	2/25/17

DIMENSIONS SHOWN IN PARENTHESES ARE FOR INFORMATION ONLY. DIMENSIONS ARE IN MILLIMETERS.	
1 = 1" = 25.4 mm 1/8" = 3.175 mm 1/4" = 6.35 mm 3/8" = 9.525 mm 1/2" = 12.7 mm 5/8" = 15.875 mm 3/4" = 19.05 mm 7/8" = 22.225 mm 1" = 25.4 mm	SCALE: 1/1" = 1'
1. ALL DIMENSIONS ARE TO FACE UNLESS OTHERWISE NOTED. 2. DIMENSIONS TO FACE UNLESS OTHERWISE NOTED. 3. DIMENSIONS TO CENTERLINE UNLESS OTHERWISE NOTED. 4. DIMENSIONS TO SURFACE UNLESS OTHERWISE NOTED. 5. DIMENSIONS TO CENTERLINE UNLESS OTHERWISE NOTED. 6. DIMENSIONS TO SURFACE UNLESS OTHERWISE NOTED. 7. DIMENSIONS TO CENTERLINE UNLESS OTHERWISE NOTED. 8. DIMENSIONS TO SURFACE UNLESS OTHERWISE NOTED. 9. DIMENSIONS TO CENTERLINE UNLESS OTHERWISE NOTED. 10. DIMENSIONS TO SURFACE UNLESS OTHERWISE NOTED. 11. DIMENSIONS TO CENTERLINE UNLESS OTHERWISE NOTED. 12. DIMENSIONS TO SURFACE UNLESS OTHERWISE NOTED. 13. DIMENSIONS TO CENTERLINE UNLESS OTHERWISE NOTED. 14. DIMENSIONS TO SURFACE UNLESS OTHERWISE NOTED. 15. DIMENSIONS TO CENTERLINE UNLESS OTHERWISE NOTED. 16. DIMENSIONS TO SURFACE UNLESS OTHERWISE NOTED. 17. DIMENSIONS TO CENTERLINE UNLESS OTHERWISE NOTED. 18. DIMENSIONS TO SURFACE UNLESS OTHERWISE NOTED. 19. DIMENSIONS TO CENTERLINE UNLESS OTHERWISE NOTED. 20. DIMENSIONS TO SURFACE UNLESS OTHERWISE NOTED. 21. DIMENSIONS TO CENTERLINE UNLESS OTHERWISE NOTED. 22. DIMENSIONS TO SURFACE UNLESS OTHERWISE NOTED. 23. DIMENSIONS TO CENTERLINE UNLESS OTHERWISE NOTED. 24. DIMENSIONS TO SURFACE UNLESS OTHERWISE NOTED. 25. DIMENSIONS TO CENTERLINE UNLESS OTHERWISE NOTED. 26. DIMENSIONS TO SURFACE UNLESS OTHERWISE NOTED. 27. DIMENSIONS TO CENTERLINE UNLESS OTHERWISE NOTED. 28. DIMENSIONS TO SURFACE UNLESS OTHERWISE NOTED. 29. DIMENSIONS TO CENTERLINE UNLESS OTHERWISE NOTED. 30. DIMENSIONS TO SURFACE UNLESS OTHERWISE NOTED. 31. DIMENSIONS TO CENTERLINE UNLESS OTHERWISE NOTED. 32. DIMENSIONS TO SURFACE UNLESS OTHERWISE NOTED. 33. DIMENSIONS TO CENTERLINE UNLESS OTHERWISE NOTED. 34. DIMENSIONS TO SURFACE UNLESS OTHERWISE NOTED. 35. DIMENSIONS TO CENTERLINE UNLESS OTHERWISE NOTED. 36. DIMENSIONS TO SURFACE UNLESS OTHERWISE NOTED. 37. DIMENSIONS TO CENTERLINE UNLESS OTHERWISE NOTED. 38. DIMENSIONS TO SURFACE UNLESS OTHERWISE NOTED. 39. DIMENSIONS TO CENTERLINE UNLESS OTHERWISE NOTED. 40. DIMENSIONS TO SURFACE UNLESS OTHERWISE NOTED. 41. DIMENSIONS TO CENTERLINE UNLESS OTHERWISE NOTED. 42. DIMENSIONS TO SURFACE UNLESS OTHERWISE NOTED. 43. DIMENSIONS TO CENTERLINE UNLESS OTHERWISE NOTED. 44. DIMENSIONS TO SURFACE UNLESS OTHERWISE NOTED. 45. DIMENSIONS TO CENTERLINE UNLESS OTHERWISE NOTED. 46. DIMENSIONS TO SURFACE UNLESS OTHERWISE NOTED. 47. DIMENSIONS TO CENTERLINE UNLESS OTHERWISE NOTED. 48. DIMENSIONS TO SURFACE UNLESS OTHERWISE NOTED. 49. DIMENSIONS TO CENTERLINE UNLESS OTHERWISE NOTED. 50. DIMENSIONS TO SURFACE UNLESS OTHERWISE NOTED. 51. DIMENSIONS TO CENTERLINE UNLESS OTHERWISE NOTED. 52. DIMENSIONS TO SURFACE UNLESS OTHERWISE NOTED. 53. DIMENSIONS TO CENTERLINE UNLESS OTHERWISE NOTED. 54. DIMENSIONS TO SURFACE UNLESS OTHERWISE NOTED. 55. DIMENSIONS TO CENTERLINE UNLESS OTHERWISE NOTED. 56. DIMENSIONS TO SURFACE UNLESS OTHERWISE NOTED. 57. DIMENSIONS TO CENTERLINE UNLESS OTHERWISE NOTED. 58. DIMENSIONS TO SURFACE UNLESS OTHERWISE NOTED. 59. DIMENSIONS TO CENTERLINE UNLESS OTHERWISE NOTED. 60. DIMENSIONS TO SURFACE UNLESS OTHERWISE NOTED. 61. DIMENSIONS TO CENTERLINE UNLESS OTHERWISE NOTED. 62. DIMENSIONS TO SURFACE UNLESS OTHERWISE NOTED. 63. DIMENSIONS TO CENTERLINE UNLESS OTHERWISE NOTED. 64. DIMENSIONS TO SURFACE UNLESS OTHERWISE NOTED. 65. DIMENSIONS TO CENTERLINE UNLESS OTHERWISE NOTED. 66. DIMENSIONS TO SURFACE UNLESS OTHERWISE NOTED. 67. DIMENSIONS TO CENTERLINE UNLESS OTHERWISE NOTED. 68. DIMENSIONS TO SURFACE UNLESS OTHERWISE NOTED. 69. DIMENSIONS TO CENTERLINE UNLESS OTHERWISE NOTED. 70. DIMENSIONS TO SURFACE UNLESS OTHERWISE NOTED. 71. DIMENSIONS TO CENTERLINE UNLESS OTHERWISE NOTED. 72. DIMENSIONS TO SURFACE UNLESS OTHERWISE NOTED. 73. DIMENSIONS TO CENTERLINE UNLESS OTHERWISE NOTED. 74. DIMENSIONS TO SURFACE UNLESS OTHERWISE NOTED. 75. DIMENSIONS TO CENTERLINE UNLESS OTHERWISE NOTED. 76. DIMENSIONS TO SURFACE UNLESS OTHERWISE NOTED. 77. DIMENSIONS TO CENTERLINE UNLESS OTHERWISE NOTED. 78. DIMENSIONS TO SURFACE UNLESS OTHERWISE NOTED. 79. DIMENSIONS TO CENTERLINE UNLESS OTHERWISE NOTED. 80. DIMENSIONS TO SURFACE UNLESS OTHERWISE NOTED. 81. DIMENSIONS TO CENTERLINE UNLESS OTHERWISE NOTED. 82. DIMENSIONS TO SURFACE UNLESS OTHERWISE NOTED. 83. DIMENSIONS TO CENTERLINE UNLESS OTHERWISE NOTED. 84. DIMENSIONS TO SURFACE UNLESS OTHERWISE NOTED. 85. DIMENSIONS TO CENTERLINE UNLESS OTHERWISE NOTED. 86. DIMENSIONS TO SURFACE UNLESS OTHERWISE NOTED. 87. DIMENSIONS TO CENTERLINE UNLESS OTHERWISE NOTED. 88. DIMENSIONS TO SURFACE UNLESS OTHERWISE NOTED. 89. DIMENSIONS TO CENTERLINE UNLESS OTHERWISE NOTED. 90. DIMENSIONS TO SURFACE UNLESS OTHERWISE NOTED. 91. DIMENSIONS TO CENTERLINE UNLESS OTHERWISE NOTED. 92. DIMENSIONS TO SURFACE UNLESS OTHERWISE NOTED. 93. DIMENSIONS TO CENTERLINE UNLESS OTHERWISE NOTED. 94. DIMENSIONS TO SURFACE UNLESS OTHERWISE NOTED. 95. DIMENSIONS TO CENTERLINE UNLESS OTHERWISE NOTED. 96. DIMENSIONS TO SURFACE UNLESS OTHERWISE NOTED. 97. DIMENSIONS TO CENTERLINE UNLESS OTHERWISE NOTED. 98. DIMENSIONS TO SURFACE UNLESS OTHERWISE NOTED. 99. DIMENSIONS TO CENTERLINE UNLESS OTHERWISE NOTED. 100. DIMENSIONS TO SURFACE UNLESS OTHERWISE NOTED.	1. ALL DIMENSIONS ARE TO FACE UNLESS OTHERWISE NOTED. 2. DIMENSIONS TO FACE UNLESS OTHERWISE NOTED. 3. DIMENSIONS TO CENTERLINE UNLESS OTHERWISE NOTED. 4. DIMENSIONS TO SURFACE UNLESS OTHERWISE NOTED. 5. DIMENSIONS TO CENTERLINE UNLESS OTHERWISE NOTED. 6. DIMENSIONS TO SURFACE UNLESS OTHERWISE NOTED. 7. DIMENSIONS TO CENTERLINE UNLESS OTHERWISE NOTED. 8. DIMENSIONS TO SURFACE UNLESS OTHERWISE NOTED. 9. DIMENSIONS TO CENTERLINE UNLESS OTHERWISE NOTED. 10. DIMENSIONS TO SURFACE UNLESS OTHERWISE NOTED. 11. DIMENSIONS TO CENTERLINE UNLESS OTHERWISE NOTED. 12. DIMENSIONS TO SURFACE UNLESS OTHERWISE NOTED. 13. DIMENSIONS TO CENTERLINE UNLESS OTHERWISE NOTED. 14. DIMENSIONS TO SURFACE UNLESS OTHERWISE NOTED. 15. DIMENSIONS TO CENTERLINE UNLESS OTHERWISE NOTED. 16. DIMENSIONS TO SURFACE UNLESS OTHERWISE NOTED. 17. DIMENSIONS TO CENTERLINE UNLESS OTHERWISE NOTED. 18. DIMENSIONS TO SURFACE UNLESS OTHERWISE NOTED. 19. DIMENSIONS TO CENTERLINE UNLESS OTHERWISE NOTED. 20. DIMENSIONS TO SURFACE UNLESS OTHERWISE NOTED. 21. DIMENSIONS TO CENTERLINE UNLESS OTHERWISE NOTED. 22. DIMENSIONS TO SURFACE UNLESS OTHERWISE NOTED. 23. DIMENSIONS TO CENTERLINE UNLESS OTHERWISE NOTED. 24. DIMENSIONS TO SURFACE UNLESS OTHERWISE NOTED. 25. DIMENSIONS TO CENTERLINE UNLESS OTHERWISE NOTED. 26. DIMENSIONS TO SURFACE UNLESS OTHERWISE NOTED. 27. DIMENSIONS TO CENTERLINE UNLESS OTHERWISE NOTED. 28. DIMENSIONS TO SURFACE UNLESS OTHERWISE NOTED. 29. DIMENSIONS TO CENTERLINE UNLESS OTHERWISE NOTED. 30. DIMENSIONS TO SURFACE UNLESS OTHERWISE NOTED. 31. DIMENSIONS TO CENTERLINE UNLESS OTHERWISE NOTED. 32. DIMENSIONS TO SURFACE UNLESS OTHERWISE NOTED. 33. DIMENSIONS TO CENTERLINE UNLESS OTHERWISE NOTED. 34. DIMENSIONS TO SURFACE UNLESS OTHERWISE NOTED. 35. DIMENSIONS TO CENTERLINE UNLESS OTHERWISE NOTED. 36. DIMENSIONS TO SURFACE UNLESS OTHERWISE NOTED. 37. DIMENSIONS TO CENTERLINE UNLESS OTHERWISE NOTED. 38. DIMENSIONS TO SURFACE UNLESS OTHERWISE NOTED. 39. DIMENSIONS TO CENTERLINE UNLESS OTHERWISE NOTED. 40. DIMENSIONS TO SURFACE UNLESS OTHERWISE NOTED. 41. DIMENSIONS TO CENTERLINE UNLESS OTHERWISE NOTED. 42. DIMENSIONS TO SURFACE UNLESS OTHERWISE NOTED. 43. DIMENSIONS TO CENTERLINE UNLESS OTHERWISE NOTED. 44. DIMENSIONS TO SURFACE UNLESS OTHERWISE NOTED. 45. DIMENSIONS TO CENTERLINE UNLESS OTHERWISE NOTED. 46. DIMENSIONS TO SURFACE UNLESS OTHERWISE NOTED. 47. DIMENSIONS TO CENTERLINE UNLESS OTHERWISE NOTED. 48. DIMENSIONS TO SURFACE UNLESS OTHERWISE NOTED. 49. DIMENSIONS TO CENTERLINE UNLESS OTHERWISE NOTED. 50. DIMENSIONS TO SURFACE UNLESS OTHERWISE NOTED. 51. DIMENSIONS TO CENTERLINE UNLESS OTHERWISE NOTED. 52. DIMENSIONS TO SURFACE UNLESS OTHERWISE NOTED. 53. DIMENSIONS TO CENTERLINE UNLESS OTHERWISE NOTED. 54. DIMENSIONS TO SURFACE UNLESS OTHERWISE NOTED. 55. DIMENSIONS TO CENTERLINE UNLESS OTHERWISE NOTED. 56. DIMENSIONS TO SURFACE UNLESS OTHERWISE NOTED. 57. DIMENSIONS TO CENTERLINE UNLESS OTHERWISE NOTED. 58. DIMENSIONS TO SURFACE UNLESS OTHERWISE NOTED. 59. DIMENSIONS TO CENTERLINE UNLESS OTHERWISE NOTED. 60. DIMENSIONS TO SURFACE UNLESS OTHERWISE NOTED. 61. DIMENSIONS TO CENTERLINE UNLESS OTHERWISE NOTED. 62. DIMENSIONS TO SURFACE UNLESS OTHERWISE NOTED. 63. DIMENSIONS TO CENTERLINE UNLESS OTHERWISE NOTED. 64. DIMENSIONS TO SURFACE UNLESS OTHERWISE NOTED. 65. DIMENSIONS TO CENTERLINE UNLESS OTHERWISE NOTED. 66. DIMENSIONS TO SURFACE UNLESS OTHERWISE NOTED. 67. DIMENSIONS TO CENTERLINE UNLESS OTHERWISE NOTED. 68. DIMENSIONS TO SURFACE UNLESS OTHERWISE NOTED. 69. DIMENSIONS TO CENTERLINE UNLESS OTHERWISE NOTED. 70. DIMENSIONS TO SURFACE UNLESS OTHERWISE NOTED. 71. DIMENSIONS TO CENTERLINE UNLESS OTHERWISE NOTED. 72. DIMENSIONS TO SURFACE UNLESS OTHERWISE NOTED. 73. DIMENSIONS TO CENTERLINE UNLESS OTHERWISE NOTED. 74. DIMENSIONS TO SURFACE UNLESS OTHERWISE NOTED. 75. DIMENSIONS TO CENTERLINE UNLESS OTHERWISE NOTED. 76. DIMENSIONS TO SURFACE UNLESS OTHERWISE NOTED. 77. DIMENSIONS TO CENTERLINE UNLESS OTHERWISE NOTED. 78. DIMENSIONS TO SURFACE UNLESS OTHERWISE NOTED. 79. DIMENSIONS TO CENTERLINE UNLESS OTHERWISE NOTED. 80. DIMENSIONS TO SURFACE UNLESS OTHERWISE NOTED. 81. DIMENSIONS TO CENTERLINE UNLESS OTHERWISE NOTED. 82. DIMENSIONS TO SURFACE UNLESS OTHERWISE NOTED. 83. DIMENSIONS TO CENTERLINE UNLESS OTHERWISE NOTED. 84. DIMENSIONS TO SURFACE UNLESS OTHERWISE NOTED. 85. DIMENSIONS TO CENTERLINE UNLESS OTHERWISE NOTED. 86. DIMENSIONS TO SURFACE UNLESS OTHERWISE NOTED. 87. DIMENSIONS TO CENTERLINE UNLESS OTHERWISE NOTED. 88. DIMENSIONS TO SURFACE UNLESS OTHERWISE NOTED. 89. DIMENSIONS TO CENTERLINE UNLESS OTHERWISE NOTED. 90. DIMENSIONS TO SURFACE UNLESS OTHERWISE NOTED. 91. DIMENSIONS TO CENTERLINE UNLESS OTHERWISE NOTED. 92. DIMENSIONS TO SURFACE UNLESS OTHERWISE NOTED. 93. DIMENSIONS TO CENTERLINE UNLESS OTHERWISE NOTED. 94. DIMENSIONS TO SURFACE UNLESS OTHERWISE NOTED. 95. DIMENSIONS TO CENTERLINE UNLESS OTHERWISE NOTED. 96. DIMENSIONS TO SURFACE UNLESS OTHERWISE NOTED. 97. DIMENSIONS TO CENTERLINE UNLESS OTHERWISE NOTED. 98. DIMENSIONS TO SURFACE UNLESS OTHERWISE NOTED. 99. DIMENSIONS TO CENTERLINE UNLESS OTHERWISE NOTED. 100. DIMENSIONS TO SURFACE UNLESS OTHERWISE NOTED.

NO.	DESCRIPTION	UNIT	QTY	UNIT PRICE	TOTAL PRICE
21	ZONE 0-8, C-6	AS34E951 (PRIMARY)	4		
22	ZONE C-6 (2X1)	A030M97 (ALTERNATE)	8		
23	ZONE C-6 (2X1)	A030M97 (ALTERNATE)	8		
24	ZONE 1-5, THOR-LIFT BASE	A030M97 (ALTERNATE)	8		
25	ZONE 2-5, THOR-LIFT BASE	A030M97 (ALTERNATE)	8		
26	ZONE A-2, THOR-LIFT BASE	A030M97 (ALTERNATE)	8		

SPRING-ISOLATED GENERATOR SETS: GROUND LEVEL INSTALLATIONS

CUMMINS GENSET MODEL	CONFIGURATION	SEISMIC ISOLATOR		ATTACHMENT TO STEEL		ATTACHMENT TO CONCRETE		CONCRETE COMPRESSIVE STRENGTH	SLAB THICKNESS	
		MODEL	QTY	SEISMIC LEVEL	ISOLATOR ATTACHMENT TO STEEL	SEISMIC LEVEL	ISOLATOR ATTACHMENT TO CONCRETE			
DODAA DODAB DODAC	OPEN OR WITH F183 ENCLOSURE	A034E951 (PRIMARY)	4	SDS-2.48	(4) PER ISOLATOR (16 TOTAL) Ø 3/4" GRADE 2/A514M A307 BOLTS	(4) PER ISOLATOR (16 TOTAL) K1M1K BOLT T2-CS 3/4"	4.75"	11.0"	4000 PSI MIN.	12.0"
		A049M413 (ALTERNATE)	4	Z/H=1.0	(4) PER ISOLATOR (32 TOTAL) Ø 3/4" GRADE 2/A514M A307 BOLTS	(4) PER ISOLATOR (32 TOTAL) K1M1K BOLT T2-SS-316 3/4"	7.362"	11.0"	4000 PSI MIN.	12.0"
DODAA DODAB DODAC	THOR LIFT BASE MOUNTED GENSET	A034E951 (PRIMARY)	8	SDS-2.48	(8) PER ISOLATOR (64 TOTAL) Ø 3/4" GRADE 2/A514M A307 BOLTS	(8) PER ISOLATOR (64 TOTAL) K1M1K BOLT T2-CS 3/4"	4.75"	11.0"	4000 PSI MIN.	12.0"
		A049M413 (ALTERNATE)	8	Z/H=1.0	(8) PER ISOLATOR (128 TOTAL) Ø 3/4" GRADE 2/A514M A307 BOLTS	(8) PER ISOLATOR (128 TOTAL) K1M1K BOLT T2-SS-316 3/4"	7.362"	11.0"	4000 PSI MIN.	12.0"

SPRING-ISOLATED GENERATOR SETS: ROOF LEVEL INSTALLATIONS

CUMMINS GENSET MODEL	CONFIGURATION	SEISMIC ISOLATOR		ATTACHMENT TO STEEL		ATTACHMENT TO CONCRETE		CONCRETE COMPRESSIVE STRENGTH	SLAB THICKNESS	
		MODEL	QTY	SEISMIC LEVEL	ISOLATOR ATTACHMENT TO STEEL	SEISMIC LEVEL	ISOLATOR ATTACHMENT TO CONCRETE			
DODAA DODAB DODAC	OPEN OR WITH F183 ENCLOSURE	A034E951 (PRIMARY)	4	SDS-2.00	(4) PER ISOLATOR (16 TOTAL) Ø 3/4" GRADE 2/A514M A307 BOLTS	(4) PER ISOLATOR (16 TOTAL) K1M1K BOLT T2-CS 3/4"	4.75"	11.0"	4000 PSI MIN.	8.0"
		A049M413 (ALTERNATE)	4	Z/H=1.0	(4) PER ISOLATOR (32 TOTAL) Ø 3/4" GRADE 2/A514M A307 BOLTS	(4) PER ISOLATOR (32 TOTAL) K1M1K BOLT T2-SS-316 3/4"	7.362"	11.0"	4000 PSI MIN.	12.0"
DODAA DODAB DODAC	THOR LIFT BASE MOUNTED GENSET	A034E951 (PRIMARY)	8	SDS-2.00	(8) PER ISOLATOR (64 TOTAL) Ø 3/4" GRADE 2/A514M A307 BOLTS	(8) PER ISOLATOR (64 TOTAL) K1M1K BOLT T2-CS 3/4"	4.75"	11.0"	4000 PSI MIN.	8.0"
		A049M413 (ALTERNATE)	8	Z/H=1.0	(8) PER ISOLATOR (128 TOTAL) Ø 3/4" GRADE 2/A514M A307 BOLTS	(8) PER ISOLATOR (128 TOTAL) K1M1K BOLT T2-SS-316 3/4"	7.362"	11.0"	4000 PSI MIN.	12.0"

RIGID MOUNTED GENERATOR SETS: GROUND LEVEL INSTALLATIONS

CUMMINS GENSET MODEL	CONFIGURATION	SEISMIC LEVEL		ATTACHMENT TO STEEL		ATTACHMENT TO CONCRETE		CONCRETE COMPRESSIVE STRENGTH	SLAB THICKNESS
		SEISMIC LEVEL	QTY	SKID/TANK ATTACHMENT TO STEEL	SEISMIC LEVEL	SKID/TANK ATTACHMENT TO CONCRETE			
DODAA DODAB DODAC	OPEN OR WITH F183 ENCLOSURE	SDS-2.48	4	(4) TOTAL Ø 3/4" A514M A307 BOLTS	(4) TOTAL HIT-RE 500 V3 + HAS B7 3/4"	6.22"	10.0"	4000 PSI MIN.	10.0"
		Z/H=0.0	4	(4) TOTAL Ø 3/4" A514M A307 BOLTS	(8) TOTAL K1M1K BOLT T2-CS 3/4"	4.75"	6.0"	4000 PSI MIN.	8.0"
DODAA DODAB DODAC	THOR LIFT BASE MOUNTED GENSET	SDS-2.48	8	(8) TOTAL Ø 5/8" GRADE 2/A514M A307 BOLTS	(12) TOTAL HIT-RE 500 V3 + HAS B7 5/8"	5.433"	10.0"	4000 PSI MIN.	10.0"
		Z/H=0.0	8	(10) TOTAL Ø 5/8" GRADE 2/A514M A325 BOLTS	(10) TOTAL HIT-RE 500 V3 + HAS B7 5/8"	10.748"	14.0"	4000 PSI MIN.	14.0"
DODAA DODAB DODAC	THOR LIFT BASE MOUNTED GENSET	SDS-2.48	8	(8) TOTAL Ø 3/4" A514M A307 BOLTS	(12) TOTAL HIT-RE 500 V3 + HAS B7 5/8"	12.48"	10.0"	4000 PSI MIN.	10.0"
		Z/H=0.0	8	(8) TOTAL Ø 3/4" A514M A307 BOLTS	(8) TOTAL K1M1K BOLT T2-CS 3/4"	4.75"	6.0"	4000 PSI MIN.	8.0"
DODAA DODAB DODAC	THOR LIFT BASE MOUNTED GENSET	SDS-2.48	8	(12) TOTAL Ø 5/8" GRADE 2/A514M A307 BOLTS	(10) TOTAL HIT-RE 500 V3 + HAS B7 5/8"	4.528"	10.0"	4000 PSI MIN.	10.0"
		Z/H=0.0	8	(10) TOTAL Ø 5/8" GRADE 2/A514M A307 BOLTS	(10) TOTAL HIT-RE 500 V3 + HAS B7 5/8"	8.071"	11.0"	4000 PSI MIN.	10.0"
DODAA DODAB DODAC	THOR LIFT BASE MOUNTED GENSET	SDS-2.48	8	(12) TOTAL Ø 5/8" GRADE 2/A514M A307 BOLTS	(12) TOTAL HIT-RE 500 V3 + HAS B7 5/8"	7.771"	11.0"	4000 PSI MIN.	10.0"
		Z/H=0.0	8	(12) TOTAL Ø 5/8" GRADE 2/A514M A307 BOLTS	(12) TOTAL HIT-RE 500 V3 + HAS B7 5/8"	7.771"	11.0"	4000 PSI MIN.	10.0"

NO.	DESCRIPTION	UNIT	QTY	UNIT PRICE	TOTAL PRICE
1	ZONE 0-8, C-6	AS34E951 (PRIMARY)	4		
2	ZONE C-6 (2X1)	A030M97 (ALTERNATE)	8		
3	ZONE C-6 (2X1)	A030M97 (ALTERNATE)	8		
4	ZONE 1-5, THOR-LIFT BASE	A030M97 (ALTERNATE)	8		
5	ZONE 2-5, THOR-LIFT BASE	A030M97 (ALTERNATE)	8		
6	ZONE A-2, THOR-LIFT BASE	A030M97 (ALTERNATE)	8		

DESIGNER: [Signature]

CHECKED: [Signature]

DATE: 11/17/17

SCALE: 1/1"

PROJECT: [Project Name]

CLIENT: [Client Name]

LOCATION: [Location]

NO. 1 WRITING

NO. 2 THICKS

NO. 3 THICKS

NO. 4 THICKS

NO. 5 THICKS

NO. 6 THICKS

NO. 7 THICKS

NO. 8 THICKS

NO. 9 THICKS

NO. 10 THICKS

NO. 11 THICKS

NO. 12 THICKS

NO. 13 THICKS

NO. 14 THICKS

NO. 15 THICKS

NO. 16 THICKS

NO. 17 THICKS

NO. 18 THICKS

NO. 19 THICKS

NO. 20 THICKS

NO. 21 THICKS

NO. 22 THICKS

NO. 23 THICKS

NO. 24 THICKS

NO. 25 THICKS

NO. 26 THICKS

NO. 27 THICKS

NO. 28 THICKS

NO. 29 THICKS

NO. 30 THICKS

NO. 31 THICKS

NO. 32 THICKS

NO. 33 THICKS

NO. 34 THICKS

NO. 35 THICKS

NO. 36 THICKS

NO. 37 THICKS

NO. 38 THICKS

NO. 39 THICKS

NO. 40 THICKS

NO. 41 THICKS

NO. 42 THICKS

NO. 43 THICKS

NO. 44 THICKS

NO. 45 THICKS

NO. 46 THICKS

NO. 47 THICKS

NO. 48 THICKS

NO. 49 THICKS

NO. 50 THICKS

NO. 51 THICKS

NO. 52 THICKS

NO. 53 THICKS

NO. 54 THICKS

NO. 55 THICKS

NO. 56 THICKS

NO. 57 THICKS

NO. 58 THICKS

NO. 59 THICKS

NO. 60 THICKS

NO. 61 THICKS

NO. 62 THICKS

NO. 63 THICKS

NO. 64 THICKS

NO. 65 THICKS

NO. 66 THICKS

NO. 67 THICKS

NO. 68 THICKS

NO. 69 THICKS

NO. 70 THICKS

NO. 71 THICKS

NO. 72 THICKS

NO. 73 THICKS

NO. 74 THICKS

NO. 75 THICKS

NO. 76 THICKS

NO. 77 THICKS

NO. 78 THICKS

NO. 79 THICKS

NO. 80 THICKS

NO. 81 THICKS

NO. 82 THICKS

NO. 83 THICKS

NO. 84 THICKS

NO. 85 THICKS

NO. 86 THICKS

NO. 87 THICKS

NO. 88 THICKS

NO. 89 THICKS

NO. 90 THICKS

NO. 91 THICKS

NO. 92 THICKS

NO. 93 THICKS

NO. 94 THICKS

NO. 95 THICKS

NO. 96 THICKS

NO. 97 THICKS

NO. 98 THICKS

NO. 99 THICKS

NO. 100 THICKS

Provide 12" minimum slab under generator

NO.	DATE	BY	REVISION
1	01/23/2015	MM	ISSUE FOR CONSTRUCTION
2	02/10/2015	MM	REVISED TO REFLECT CHANGES
3	03/02/2015	MM	REVISED TO REFLECT CHANGES
4	03/10/2015	MM	REVISED TO REFLECT CHANGES
5	03/10/2015	MM	REVISED TO REFLECT CHANGES

RIGID MOUNTED GENERATOR SETS: ROOF LEVEL INSTALLATIONS

CUMMINS GENSET MODEL	CONFIGURATION	ATTACHMENT TO STEEL			ATTACHMENT TO CONCRETE		
		SEISMIC LEVEL	SKID/TANK ATTACHMENT TO STEEL	SEISMIC LEVEL	SKID/TANK ATTACHMENT TO CONCRETE	MINIMUM ANCHOR EMBEDMENT (FROM ANCHOR LOCATION)	CONCRETE COMPRESSIVE STRENGTH
DODAA DODAB DODAC	OPEN OR WITH F183 ENCLOSURE	SDS=2.00 Z/H=1.0	(4) TOTAL Ø3/4" ASTM A307 BOLTS	(4) TOTAL HIT-RE 500 V3 + HAS BT 3/4	6.22"	10.0"	10.0"
	OPEN LIFT BASE MOUNTED GENSET		(4) TOTAL Ø3/4" ASTM A307 BOLTS	(8) TOTAL KWIK BOLT TZ-CS 3/4	4.75"	6.0"	8.0"
	OPEN SUB-BASE FUEL TANK (270-720 GAL)		(12) TOTAL Ø5/8" GRADE 2/ASTM A307 BOLTS	(12) TOTAL HIT-RE 500 V3 + HAS BT 5/8	5.433"	10.0"	10.0"
	OPEN SUB-BASE FUEL TANK (1470 GAL)		(10) TOTAL Ø5/8" GRADE 5/ASTM A325 BOLTS	(10) TOTAL HIT-RE 500 V3 + HAS BT 5/8	10.748"	14.0"	14.0"
THOR LIFT BASE MOUNTED GENSET	(8) TOTAL Ø3/4" ASTM A307 BOLTS	(8) TOTAL KWIK BOLT TZ-CS 3/4	4.75"	6.0"	8.0"		
THOR LIFT BASE MOUNTED GENSET with fuel tank 270-702 GAL	(12) TOTAL Ø5/8" GRADE 2/ASTM A325 BOLTS	(12) TOTAL HIT-RE 500 V3 + HAS BT 5/8	4.528"	10.0"	10.0"		
THOR LIFT BASE MOUNTED GENSET with fuel tank 1470 GAL	(10) TOTAL Ø5/8" GRADE 2/ASTM A307 BOLTS	(10) TOTAL HIT-RE 500 V3 + HAS BT 5/8	8.071"	11.0"	10.0"		
THOR LIFT BASE MOUNTED GENSET with fuel tank 2050 GAL	(12) TOTAL Ø5/8" GRADE 2/ASTM A307 BOLTS	(12) TOTAL HIT-RE 500 V3 + HAS BT 5/8	7.771"	11.0"	10.0"		

DESIGNER'S SPECIFICATIONS

1. ALL DIMENSIONS UNLESS OTHERWISE NOTED SHALL BE IN INCHES.

2. ALL DIMENSIONS SHALL BE TO FACE UNLESS OTHERWISE NOTED.

3. ALL DIMENSIONS SHALL BE TO CENTER UNLESS OTHERWISE NOTED.

4. ALL DIMENSIONS SHALL BE TO EDGE UNLESS OTHERWISE NOTED.

5. ALL DIMENSIONS SHALL BE TO SURFACE UNLESS OTHERWISE NOTED.

6. ALL DIMENSIONS SHALL BE TO CENTERLINE UNLESS OTHERWISE NOTED.

7. ALL DIMENSIONS SHALL BE TO CENTERLINE UNLESS OTHERWISE NOTED.

8. ALL DIMENSIONS SHALL BE TO CENTERLINE UNLESS OTHERWISE NOTED.

9. ALL DIMENSIONS SHALL BE TO CENTERLINE UNLESS OTHERWISE NOTED.

10. ALL DIMENSIONS SHALL BE TO CENTERLINE UNLESS OTHERWISE NOTED.

11. ALL DIMENSIONS SHALL BE TO CENTERLINE UNLESS OTHERWISE NOTED.

12. ALL DIMENSIONS SHALL BE TO CENTERLINE UNLESS OTHERWISE NOTED.

13. ALL DIMENSIONS SHALL BE TO CENTERLINE UNLESS OTHERWISE NOTED.

14. ALL DIMENSIONS SHALL BE TO CENTERLINE UNLESS OTHERWISE NOTED.

15. ALL DIMENSIONS SHALL BE TO CENTERLINE UNLESS OTHERWISE NOTED.

16. ALL DIMENSIONS SHALL BE TO CENTERLINE UNLESS OTHERWISE NOTED.

17. ALL DIMENSIONS SHALL BE TO CENTERLINE UNLESS OTHERWISE NOTED.

18. ALL DIMENSIONS SHALL BE TO CENTERLINE UNLESS OTHERWISE NOTED.

19. ALL DIMENSIONS SHALL BE TO CENTERLINE UNLESS OTHERWISE NOTED.

20. ALL DIMENSIONS SHALL BE TO CENTERLINE UNLESS OTHERWISE NOTED.

21. ALL DIMENSIONS SHALL BE TO CENTERLINE UNLESS OTHERWISE NOTED.

22. ALL DIMENSIONS SHALL BE TO CENTERLINE UNLESS OTHERWISE NOTED.

23. ALL DIMENSIONS SHALL BE TO CENTERLINE UNLESS OTHERWISE NOTED.

24. ALL DIMENSIONS SHALL BE TO CENTERLINE UNLESS OTHERWISE NOTED.

25. ALL DIMENSIONS SHALL BE TO CENTERLINE UNLESS OTHERWISE NOTED.

26. ALL DIMENSIONS SHALL BE TO CENTERLINE UNLESS OTHERWISE NOTED.

27. ALL DIMENSIONS SHALL BE TO CENTERLINE UNLESS OTHERWISE NOTED.

28. ALL DIMENSIONS SHALL BE TO CENTERLINE UNLESS OTHERWISE NOTED.

29. ALL DIMENSIONS SHALL BE TO CENTERLINE UNLESS OTHERWISE NOTED.

30. ALL DIMENSIONS SHALL BE TO CENTERLINE UNLESS OTHERWISE NOTED.

31. ALL DIMENSIONS SHALL BE TO CENTERLINE UNLESS OTHERWISE NOTED.

32. ALL DIMENSIONS SHALL BE TO CENTERLINE UNLESS OTHERWISE NOTED.

33. ALL DIMENSIONS SHALL BE TO CENTERLINE UNLESS OTHERWISE NOTED.

34. ALL DIMENSIONS SHALL BE TO CENTERLINE UNLESS OTHERWISE NOTED.

35. ALL DIMENSIONS SHALL BE TO CENTERLINE UNLESS OTHERWISE NOTED.

36. ALL DIMENSIONS SHALL BE TO CENTERLINE UNLESS OTHERWISE NOTED.

37. ALL DIMENSIONS SHALL BE TO CENTERLINE UNLESS OTHERWISE NOTED.

38. ALL DIMENSIONS SHALL BE TO CENTERLINE UNLESS OTHERWISE NOTED.

39. ALL DIMENSIONS SHALL BE TO CENTERLINE UNLESS OTHERWISE NOTED.

40. ALL DIMENSIONS SHALL BE TO CENTERLINE UNLESS OTHERWISE NOTED.

41. ALL DIMENSIONS SHALL BE TO CENTERLINE UNLESS OTHERWISE NOTED.

42. ALL DIMENSIONS SHALL BE TO CENTERLINE UNLESS OTHERWISE NOTED.

43. ALL DIMENSIONS SHALL BE TO CENTERLINE UNLESS OTHERWISE NOTED.

44. ALL DIMENSIONS SHALL BE TO CENTERLINE UNLESS OTHERWISE NOTED.

45. ALL DIMENSIONS SHALL BE TO CENTERLINE UNLESS OTHERWISE NOTED.

46. ALL DIMENSIONS SHALL BE TO CENTERLINE UNLESS OTHERWISE NOTED.

47. ALL DIMENSIONS SHALL BE TO CENTERLINE UNLESS OTHERWISE NOTED.

48. ALL DIMENSIONS SHALL BE TO CENTERLINE UNLESS OTHERWISE NOTED.

49. ALL DIMENSIONS SHALL BE TO CENTERLINE UNLESS OTHERWISE NOTED.

50. ALL DIMENSIONS SHALL BE TO CENTERLINE UNLESS OTHERWISE NOTED.

51. ALL DIMENSIONS SHALL BE TO CENTERLINE UNLESS OTHERWISE NOTED.

52. ALL DIMENSIONS SHALL BE TO CENTERLINE UNLESS OTHERWISE NOTED.

53. ALL DIMENSIONS SHALL BE TO CENTERLINE UNLESS OTHERWISE NOTED.

54. ALL DIMENSIONS SHALL BE TO CENTERLINE UNLESS OTHERWISE NOTED.

55. ALL DIMENSIONS SHALL BE TO CENTERLINE UNLESS OTHERWISE NOTED.

56. ALL DIMENSIONS SHALL BE TO CENTERLINE UNLESS OTHERWISE NOTED.

57. ALL DIMENSIONS SHALL BE TO CENTERLINE UNLESS OTHERWISE NOTED.

58. ALL DIMENSIONS SHALL BE TO CENTERLINE UNLESS OTHERWISE NOTED.

59. ALL DIMENSIONS SHALL BE TO CENTERLINE UNLESS OTHERWISE NOTED.

60. ALL DIMENSIONS SHALL BE TO CENTERLINE UNLESS OTHERWISE NOTED.

61. ALL DIMENSIONS SHALL BE TO CENTERLINE UNLESS OTHERWISE NOTED.

62. ALL DIMENSIONS SHALL BE TO CENTERLINE UNLESS OTHERWISE NOTED.

63. ALL DIMENSIONS SHALL BE TO CENTERLINE UNLESS OTHERWISE NOTED.

64. ALL DIMENSIONS SHALL BE TO CENTERLINE UNLESS OTHERWISE NOTED.

65. ALL DIMENSIONS SHALL BE TO CENTERLINE UNLESS OTHERWISE NOTED.

66. ALL DIMENSIONS SHALL BE TO CENTERLINE UNLESS OTHERWISE NOTED.

67. ALL DIMENSIONS SHALL BE TO CENTERLINE UNLESS OTHERWISE NOTED.

68. ALL DIMENSIONS SHALL BE TO CENTERLINE UNLESS OTHERWISE NOTED.

69. ALL DIMENSIONS SHALL BE TO CENTERLINE UNLESS OTHERWISE NOTED.

70. ALL DIMENSIONS SHALL BE TO CENTERLINE UNLESS OTHERWISE NOTED.

71. ALL DIMENSIONS SHALL BE TO CENTERLINE UNLESS OTHERWISE NOTED.

72. ALL DIMENSIONS SHALL BE TO CENTERLINE UNLESS OTHERWISE NOTED.

73. ALL DIMENSIONS SHALL BE TO CENTERLINE UNLESS OTHERWISE NOTED.

74. ALL DIMENSIONS SHALL BE TO CENTERLINE UNLESS OTHERWISE NOTED.

75. ALL DIMENSIONS SHALL BE TO CENTERLINE UNLESS OTHERWISE NOTED.

76. ALL DIMENSIONS SHALL BE TO CENTERLINE UNLESS OTHERWISE NOTED.

77. ALL DIMENSIONS SHALL BE TO CENTERLINE UNLESS OTHERWISE NOTED.

78. ALL DIMENSIONS SHALL BE TO CENTERLINE UNLESS OTHERWISE NOTED.

79. ALL DIMENSIONS SHALL BE TO CENTERLINE UNLESS OTHERWISE NOTED.

80. ALL DIMENSIONS SHALL BE TO CENTERLINE UNLESS OTHERWISE NOTED.

81. ALL DIMENSIONS SHALL BE TO CENTERLINE UNLESS OTHERWISE NOTED.

82. ALL DIMENSIONS SHALL BE TO CENTERLINE UNLESS OTHERWISE NOTED.

83. ALL DIMENSIONS SHALL BE TO CENTERLINE UNLESS OTHERWISE NOTED.

84. ALL DIMENSIONS SHALL BE TO CENTERLINE UNLESS OTHERWISE NOTED.

85. ALL DIMENSIONS SHALL BE TO CENTERLINE UNLESS OTHERWISE NOTED.

86. ALL DIMENSIONS SHALL BE TO CENTERLINE UNLESS OTHERWISE NOTED.

87. ALL DIMENSIONS SHALL BE TO CENTERLINE UNLESS OTHERWISE NOTED.

88. ALL DIMENSIONS SHALL BE TO CENTERLINE UNLESS OTHERWISE NOTED.

89. ALL DIMENSIONS SHALL BE TO CENTERLINE UNLESS OTHERWISE NOTED.

90. ALL DIMENSIONS SHALL BE TO CENTERLINE UNLESS OTHERWISE NOTED.

91. ALL DIMENSIONS SHALL BE TO CENTERLINE UNLESS OTHERWISE NOTED.

92. ALL DIMENSIONS SHALL BE TO CENTERLINE UNLESS OTHERWISE NOTED.

93. ALL DIMENSIONS SHALL BE TO CENTERLINE UNLESS OTHERWISE NOTED.

94. ALL DIMENSIONS SHALL BE TO CENTERLINE UNLESS OTHERWISE NOTED.

95. ALL DIMENSIONS SHALL BE TO CENTERLINE UNLESS OTHERWISE NOTED.

96. ALL DIMENSIONS SHALL BE TO CENTERLINE UNLESS OTHERWISE NOTED.

97. ALL DIMENSIONS SHALL BE TO CENTERLINE UNLESS OTHERWISE NOTED.

98. ALL DIMENSIONS SHALL BE TO CENTERLINE UNLESS OTHERWISE NOTED.

99. ALL DIMENSIONS SHALL BE TO CENTERLINE UNLESS OTHERWISE NOTED.

100. ALL DIMENSIONS SHALL BE TO CENTERLINE UNLESS OTHERWISE NOTED.

Regulatory Review and Approval is required prior to changing this item per PG&E 1401-01-116. This item impacts compliance with these External Regulations: EBC