



Product Submittals

Fire Alarm System

PSE Training
325 Todd Rd NW
Puyallup, WA 98371



Submittal Device List

Manufacturer	Part Number	Description	✓
NOTIFIER	CPU2-640	FIRE ALARM CONTROL PANEL CENTRAL PROCESSING UNIT	
NOTIFIER	KDM-R2	KEYBOARD DISPLAY MODULE	
NOTIFIER	DP-DISP-2	DRESS PLATE	
NOTIFIER	BMP-1	BLANK MODULE DRESS PLATE	
NOTIFIER	BP2-4	BATTERY DRESS PANEL	
NOTIFIER	DP-1B	BLANK DRESS PANEL	
NOTIFIER	DR-B4	CABINET DOOR	
NOTIFIER	SBB-B4	CABINET	
NOTIFIER	NFS-LBB	BATTERY CABINET	
NOTIFIER	UDACT-2	DIGITAL ALARM COMMUNICATOR	
HONEYWELL	HPF-PS10	REMOTE POWER SUPPLY	
NOTIFIER	FDU-80	REMOTE ANNUNCIATOR	
NOTIFIER	DNR	DUCT DETECTOR HOUSING UNIT	
NOTIFIER	DST3	SAMPLING TUBE	
NOTIFIER	FSP-951R	DUCT SMOKE DETECTOR	
NOTIFIER	FSP-951	SMOKE DETECTOR	
NOTIFIER	FST-951	HEAT DETECTOR	
NOTIFIER	B300-6	DETECTOR BASE	
NOTIFIER	FRM-1	ADDRESSABLE RELAY MODULE	
NOTIFIER	FDM-1	ADDRESSABLE DUAL MONITOR MODULE	
NOTIFIER	ISO-X	ADDRESSABLE ISOLATION MODULE	
NOTIFIER	NBG-12LX	ADDRESSABLE PULL STATION	
SYSTEM SENSOR	P2RK	HORN STROBE; OUTDOOR; RED	
SYSTEM SENSOR	SRK	STROBE; OUTDOOR; RED	
SYSTEM SENSOR	P2WLED	HORN STROBE; WHITE; WALL; LED	
SYSTEM SENSOR	PC2WLED	HORN STROBE; CEILING; WHITE	
SYSTEM SENSOR	SWLED	STROBE; WHITE; WALL; LED	
POTTER	RTS-0	ROOM TEMPERATURE SWITCH	
SPACE AGE	SSU00689	DOCUMENT RECORD BOX	
ULTRATECH	IM-12120NB	12V 12AH BATTERY	
ULTRATECH	IM-1272FA	12V 7AH BATTERY	
POWER SONIC	PS-12260	12V 26AH BATTERY	

NFS2-640 Intelligent Addressable Fire Alarm Control Panel

General

The NFS2-640 intelligent Fire Alarm Control Panel is part of the ONYX® Series of Fire Alarm Controls from NOTIFIER.

In stand-alone or network configurations, ONYX Series products meet virtually every application requirement.

The NFS2-640's modular design makes system planning easier. The panel can be configured with just a few devices for small building applications, or networked with many devices to protect a large campus or a high-rise office block. Simply add additional peripheral equipment to suit the application.

A host of other options are available, including single- or multichannel voice; firefighter's telephone; LED, LCD, or PC-based graphic annunciators; networking; advanced detection products for challenging environments; wireless fire protection; and many additional options.

NOTE: Unless called out with a version-specific "E" at the end of the part number, "NFS2-640" refers to models NFS2-640 and NFS2-640E; similarly, "CPU2-640" refers to models CPU2-640 and CPU2-640E.

Features

- Certified for seismic applications when used with the appropriate seismic mounting kit.
- Approved for Marine applications when used with listed compatible equipment. See DN-60688.
- One, expandable to two, isolated intelligent Signaling Line Circuit (SLC) Class A, B, or X.
- Wireless fire protection using SWIFT Smart Wireless Integrated Fire Technology. See DN-60820.
- Up to 159 detectors and 159 modules per SLC; 318 devices per loop/636 per FACP or network node.
 - Detectors can be any mix of ion, photo, thermal, or multi-sensor; wireless detectors are available for use with the FWSG.
 - Modules include addressable pull stations, normally open contact devices, two-wire smoke detectors, notification, or relay; wireless modules are available for use with the FWSG.
- Standard 80-character display, 640-character large display (NCA-2), or display-less (a node on a network).
- Network options:
 - High-speed network for up to 200 nodes (NFS2-3030, NFS2-640, NFS-320(C), NFS-320SYS, NCD, NCA-2, DVC-EM, ONYXWorks, NFS-3030, NFS-640, and NCA).
 - Standard network for up to 103 nodes (NFS2-3030, NFS2-640, NFS-320(C), NFS-320SYS, NCD, NCA-2, DVC-EM, ONYXWorks, NCS, NFS-3030, NFS-640, NCA, AFP-200, AFP-300/400, AFP-1010, and AM2020). Up to 54 nodes when DVC-EM is used in network paging.
- 6.0 A switch mode power supply with four Class A/B built-in Notification Appliance Circuits (NAC). Selectable System Sensor, Wheelock, or Gentex strobe synchronization.
- Built-in Alarm, Trouble, Security, and Supervisory relays.
- Field-programmable on panel or on PC.
- VeriFire® Tools online or offline programming utility. Upload/Download, save, store, check, compare, and simulate panel databases. Upgrade panel firmware.
- Autoprogramming and Walk Test reports.
- Multiple central station communication options:
 - Standard UDACT
 - Internet
 - Internet/GSM
- 80-character remote annunciators (up to 32).
- EIA-485 annunciators, including custom graphics.
- Printer interface (80-column and 40-column printers).
- History file with 800-event capacity in nonvolatile memory, plus separate 200-event alarm-only file.
- Alarm Verification selection per point, with automatic counter.
- Presignal/Positive Alarm Sequence (PAS).
- Silence inhibit and Auto Silence timer options.
- March time/temporal/California two-stage coding/strobe synchronization.
- Full QWERTY keypad.
- Battery charger supports 18 – 200 AH batteries.
- Non-alarm points for lower priority functions.
- Remote ACK/Signal Silence/System Reset/Drill using monitor modules.
- Automatic time control functions, with holiday exceptions.
- Surface Mount Technology (SMT) electronics.
- Extensive, built-in transient protection.
- Powerful Boolean logic equations.
- Support for SCS Series smoke control system in HVAC mode.



NCA-2 AS PRIMARY DISPLAY

- Backlit, 640-character display.
- Supports SCS Series smoke control system in FSCS mode when SCS is connected to the NCA-2 used as primary display.
- Supports DVC digital audio loop.
- Printer and CRT EIA-232 ports.
- EIA-485 annunciator and terminal mode ports.
- Alarm, Trouble, Supervisory, and Security relays.

SWIFT WIRELESS

- Self-healing mesh wireless protocol.
- Each SWIFT Gateway supports up to 50 devices: 1 wireless gateway and up to 49 SWIFT devices.
- Up to 4 wireless gateways can be installed with overlapping network coverage.

RELEASING FEATURES

- Ten independent hazards.
- Sophisticated cross-zone (three options).
- Delay timer and Discharge timers (adjustable).
- Abort (four options).
- Low-pressure CO₂ listed.

DIGITAL VOICE AND TELEPHONE FEATURES

- Up to eight channels of digital audio.
- 35, 50, 75, and 100/125 watt digital amplifiers (DAA2/DAX series and DS series; NCA-2 required as primary display).
- Solid-state digital message generation.
- Firefighter telephone option.
- 30- to 120-watt high-efficiency amplifiers (AA Series).
- Backup tone generator and amplifier option.
- NFS2-640 can also integrate with the FirstCommand® Emergency Communications System. See DN-60772.

HIGH-EFFICIENCY OFFLINE SWITCHING

3.0 A POWER SUPPLY (6.0 A IN ALARM)

- 120 VAC (NFS2-640); 240 VAC (NFS2-640E).
- Displays battery current/voltage on panel (with display).

FLASHSCAN® INTELLIGENT FEATURES

- Polls up to 318 devices in less than two seconds.
- Activates up to 159 outputs in less than five seconds.
- Multicolor LEDs blink device address during Walk Test.
- Fully digital, high-precision protocol (U.S. Patent 5,539,389).
- Manual sensitivity adjustment — up to nine levels.
- Pre-alarm ONYX intelligent sensing — up to nine levels.
- Day/Night automatic sensitivity adjustment.
- Sensitivity windows:
 - **Photo** – 0.5 to 2.35%/foot obscuration.
 - **High-Sensitivity Photoelectric (VIEW®)** – Open Air Protection (0.5% - 2.0%/ft. obscuration), Special Applications (0.02%-0.5%/ft. obscuration)
 - **Multi-Criteria Detector** – Open Air Protection (2.52-3.89%/ft. obscuration), Special Applications (1.13-2.52%/ft. obscuration)
- Drift compensation (U.S. Patent 5,764,142).
- Degraded mode: In the unlikely event that the CPU2-640 micro-processor fails, FlashScan detectors revert to degraded operation and can activate the CPU2-640 NAC circuits and alarm relay. Each of the four built-in panel circuits includes a Disable/Enable switch for this feature.
- Multi-detector algorithm involves nearby detectors in alarm decision (U.S. Patent 5,627,515).
- Automatic detector sensitivity testing (NFPA-72 compliant).
- Maintenance alert (two levels).
- Self-optimizing pre-alarm.

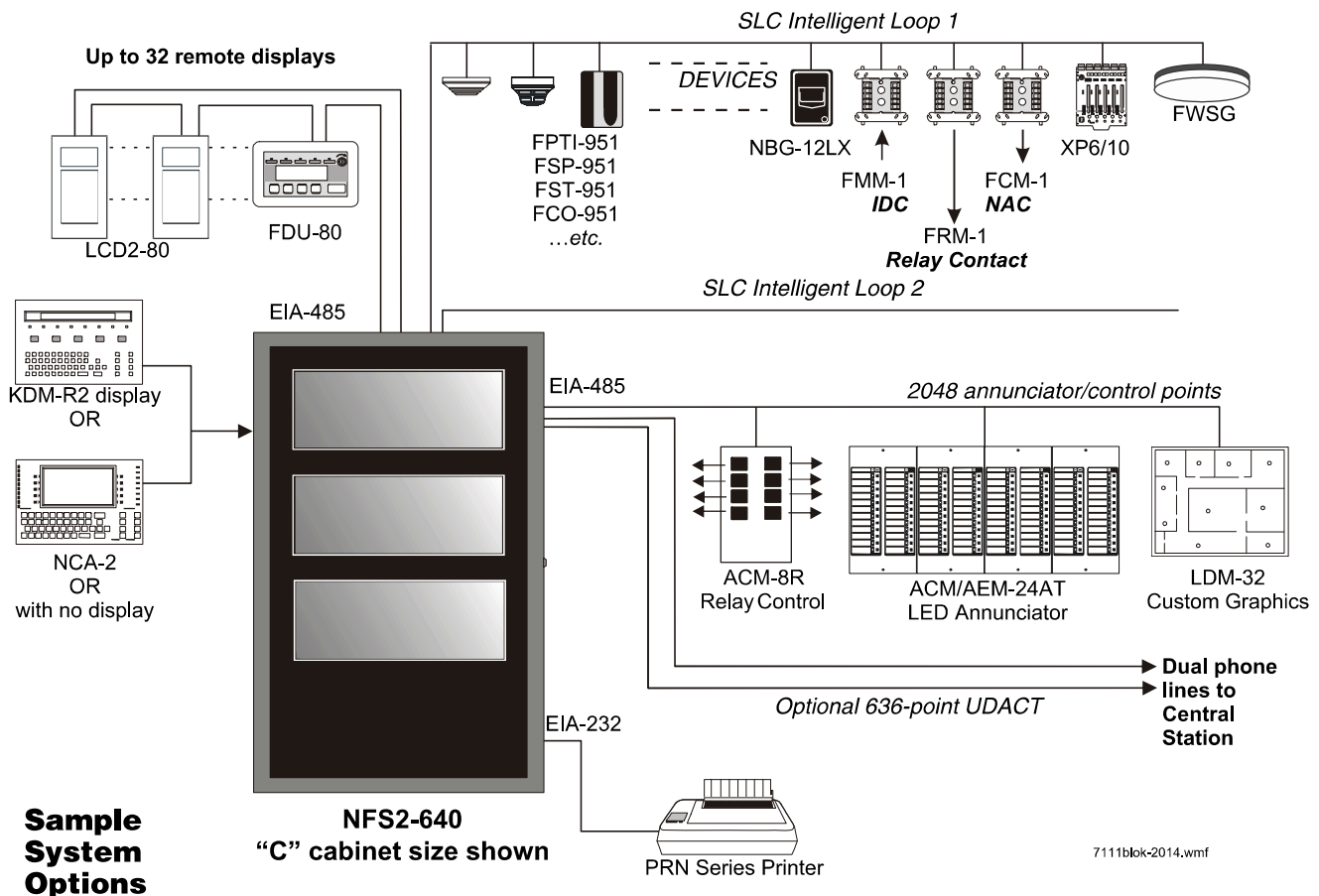

7111blok-2014.wmf

FSV-951 SERIES VIEW® (VERY INTELLIGENT EARLY WARNING) HIGH-SENSITIVITY SMOKE DETECTOR

- Advanced ONYX intelligent sensing algorithms differentiate between smoke and non-smoke signals.
- Addressable operation pinpoints the fire location.
- Ivory models (-IV) support CLIP mode as well as FlashScan.
- ULC listed models available; “A” models are ULC Listed.
- -R is retrofit, backwards compatible for use with older panels.

FCO-951-IV ADVANCED MULTI-CRITERIA FIRE/CO DETECTOR

- Detects all four major elements of a fire (smoke, heat, CO, and flame).
- 135°F (57.2°C) fixed-temperature heat detector.
- Transmits an alarm signal due to heat.
- Separate signal for life-safety CO detection.
- Optional addressable sounder base for Temp-3 (fire) or Temp-4 (CO) tone.
- Automatic drift compensation of smoke sensor and CO cell.
- High nuisance-alarm immunity.
- ULC listed models available; -A models are ULC Listed.

FPTI-951(A) INTELLIGENT MULTI-CRITERIA DETECTOR

- Combined Photoelectric Thermal and Infrared Sensor
- UL 268 7th Edition and UL 521 Listed; Canadian models CAN/ULC S529 and CAN/ULC S530
- Microprocessor-based technology; combination photo, thermal, and infrared technology.

FPC-951(A) PHOTOELECTRIC/CO SENSOR

- Combined photoelectric and carbon monoxide sensor

FSCO-95(A) INTELLIGENT CO SENSOR

- Carbon monoxide sensor

FS-OSI-RI(A) ADDRESSABLE INTELLIGENT SINGLE-ENDED BEAM SMOKE DETECTOR

- Intelligent addressable reflector-type linear optical beam smoke detector
- Fast, easy, and intuitive beam alignment indicated by directional LED arrows
- Long range coverage of 16-328 ft (5-100 m) is standard; no separate long-range kit required

FMM-4-20 GAS DETECTION MODULE

- Interface to industry-standard linear scale 4-20 mA sensors.
- Five programmable thresholds.
- FM Approved, Class 6320 (Stationary Gas Sensors/Detectors).

INTELLIGENT VESDA DETECTORS

- Intelligent aspiration smoke detectors connect directly to the SLC loop of compatible ONYX® Series panels:
 - VEA-040-A00-NTF, VEA-040-A10-NTF
 - VEP-A00-P-NTF, VEP-A10-P-NTF, VEP-A00-1P-NTF
 - VEU-A00-NTF, VEU-A10-NTF
- Models offer LED display, LCD display, or both
- Coverage options for spaces up to 69,965 square feet

FlashScan, Exclusive World-Leading Detector Protocol

At the heart of the NFS2-640 is a set of detection devices and device protocol — FlashScan (U.S. Patent 5,539,389). FlashScan is an all-digital protocol that gives superior precision and high noise immunity. In addition to providing quick identification of an active input device, this protocol can also activate many output devices in a fraction of the time required by competitive protocols. This high speed also

allows the NFS2-640 to have the largest device per loop capacity in the industry — 318 points — yet every input and output device is sampled in less than two seconds. The microprocessor-based FlashScan detectors have bicolor LEDs that can be coded to provide diagnostic information, such as device address during Walk Test.

ONYX Intelligent Sensing

Intelligent sensing is a set of software algorithms that provides the NFS2-640 with industry-leading smoke detection capability. These complex algorithms require many calculations on each reading of each detector, and are made possible by the high-speed microcomputer used by the NFS2-640.

Drift Compensation and Smoothing: Drift compensation allows the detector to retain its original ability to detect actual smoke, and resist false alarms, even as dirt accumulates. It reduces maintenance requirements by allowing the system to automatically perform the periodic sensitivity measurements required by NFPA 72. Smoothing filters are also provided by software to remove transient noise signals, such as those caused by electrical interference.

Maintenance Warnings: When the drift compensation performed for a detector reaches a certain level, the performance of the detector may be compromised, and special warnings are given. There are three warning levels: (1) Low Chamber value; (2) Maintenance Alert, indicative of dust accumulation that is near but below the allowed limit; (3) Maintenance Urgent, indicative of dust accumulation above the allowed limit.

Sensitivity Adjust: Nine sensitivity levels are provided for alarm detection. These levels can be set manually, or can change automatically between day and night. Nine levels of pre-alarm sensitivity can also be selected, based on predetermined levels of alarm. Pre-alarm operation can be latching or self-restoring, and can be used to activate special control functions.

Self-Optimizing Pre-Alarm: Each detector may be set for “Self-Optimizing” pre-alarm. In this special mode, the detector “learns” its normal environment, measuring the peak analog readings over a long period of time, and setting the pre-alarm level just above these normal peaks.

Cooperating Multi-Detector Sensing: A patented feature of ONYX intelligent sensing is the ability of a smoke sensor to consider readings from nearby sensors in making alarm or pre-alarm decisions. Without statistical sacrifice in the ability to resist false alarms, it allows a sensor to increase its sensitivity to actual smoke by a factor of almost two to one.

Field Programming Options

Autoprogram is a timesaving feature. The FACP “learns” what devices are physically connected and automatically loads them in the program with default values for all parameters. Requiring less than one minute to run, this routine allows the user to have almost immediate fire protection in a new installation, even if only a portion of the detectors are installed.

Keypad Program Edit (with KDM-R2) The NFS2-640, like all NOTIFIER intelligent panels, has the exclusive feature of program creation and editing capability from the front panel keypad, while continuing to provide fire protection. The architecture of the NFS2-640 software is such that each point entry carries its own program, including control-by-event links to other points. This allows the program to be entered with independent per-point segments, while the NFS2-640 simultaneously monitors other (already installed) points for alarm conditions.

VeriFire® Tools is an offline programming and test utility that can greatly reduce installation programming time, and increase confidence in the site-specific software. It is Windows®-based and provides technologically advanced capabilities to aid the installer. The installer may create the entire program for the NFS2-640 in the comfort of the office, test it, store a backup file, then bring it to the site and download from a laptop into the panel.

Placement of Equipment in Chassis and Cabinet

The following guidelines outline the NFS2-640's flexible system design.

Rows: The first row of equipment in the cabinet mounts in the chassis shipped with the FACP. Mount the second, third, or fourth rows of equipment in a CHS-4 series chassis or, for Digital Voice Command products, in CA-1 or CA-2. (For DVC-EM and DAA2/DAX components see *DVC Manual*; for DS series components see *DS-AMP Manual*; for DVC-AO applications, see *AA Series Installation Manual*). Other options are available; see your panel's installation manual.

Wiring: When designing the cabinet layout, consider separation of power-limited and non-power-limited wiring as discussed in the *NFS2-640 Installation Manual*.

Positions: A chassis offers four basic side-by-side positions for components; the number of modules that can be mounted in each position depends on the chassis model and the size of the individual module. There are a variety of standoffs and hardware items available for different combinations and configurations of components.

It is critical that all mounting holes of the NFS2-640 are secured with a screw or standoff to ensure continuity of Earth Ground.

Layers: The control panel's chassis accepts four layers of equipment, including the control panel. The CPU2-640 fills three positions (left to right) in the first-installed layer (the back of the chassis); its integral power supply occupies the center two positions in the next two layers; the optional display occupies (the left) two positions at the front, flush with the door. Some equipment, such as the NCA-2, may be mounted in the dress panel directly in front of the control panel. The NCA-2 can be used as a primary display for the NFS2-640 (use NCA/640-2-KIT) by directly connecting their network ports (required in Canadian stand-alone applications); see NCA-2 data sheet for mounting options (*DN-7047*).

Expansion: Installing an LEM-320 Loop Expander Module adds a second SLC loop to the control panel. The LEM-320 is mounted onto the CPU2-640, occupying the middle-right, second (back) slot on the chassis.

Networking: If networking two or more control panels, each unit requires a Network Communication Module or High-Speed Network Communication Module. (HS-NCM can support two nodes; see "Networking Options" on page 4). These modules can be installed in any option board position (see manual), and additional option boards can be mounted in front of the network communication modules.

KDM-R2 Controls and Indicators

Program Keypad: QWERTY type (*keyboard layout, see figure*).

12 LED indicators: Power; Fire Alarm; Pre-Alarm; Security; Supervisory; System Trouble; Signals Silenced; Points Disabled; Control Active; Abort; Pre-Discharge; Discharge.

Keypad Switch Controls: Acknowledge/Scroll Display; Signal Silence; Drill; System Reset; Lamp Test.

LCD Display: 80 characters (2 x 40) with long-life LED backlight.

Product Line Information

- "Configuration Guidelines" on page 4
- "Main System Components" on page 4
- "Networking Options" on page 4
- "Auxiliary Power Supplies and Batteries" on page 5
- "Audio Options" on page 5
- "Compatible Devices, EIA-232 Ports" on page 5
- "Compatible Devices, EIA-485 Ports" on page 5
- "Compatible Intelligent Devices" on page 6
- "Enclosures, Chassis, and Dress Plates" on page 7
- "Other Options" on page 8

CONFIGURATION GUIDELINES

Stand-alone and network systems require a main display. On systems with one FACP (one CPU2-640/-640E), display options are the KDM-R2 or the NCA-2. On network systems (two or more networked fire panel nodes), at least one NCD, NCA-2, NCS, or ONYXWorks annunciation device is required. Other options listed as follows.

MAIN SYSTEM COMPONENTS

CPU2-640: Central processing unit (CPU) with integral 3.0 A (6.0 A in alarm) power supply for an NFS2-640 system. Includes control panel factory-mounted on a chassis; one Signaling Line Circuit expandable to two; documentation kit. *Order one per system or as necessary (up to 103 network nodes) on a network system. (Non-English versions also available: CPU2-640-FR, CPU2-640-PO, CPU2-640-SP.)*

CPU2-640E: Same as CPU2-640 but requires 240 VAC, 1.5 A, (3.0 A in alarm). *(Non-English versions also available: CPU2-640E-PO, CPU2-640E-SP.)*

KDM-R2: 80-character backlit LCD display with QWERTY programming and control keypad. Order two BMP-1 blank modules and DP-DISP2 mounting plate separately. *Requires top row of a cabinet. Required for each stand-alone 80-character display system. The KDM-R2 may mount in network nodes to display "local" node information as long as at least one NCA-2 or NCS/ONYXWorks network display is on the system to display network information. (Non-English versions also available: KDM-R2C for ULC application, KDM-R2-FR, KDM-R2-PO, KDM-R2-SP.)*

NCA-2: Network Control Annunciator, 640 characters. On single CPU2-640/-640E systems, the optional NCA-2 can be used as the Primary Display for the panel and connects directly to the CPU2-640/-640E. On network systems (two or more networked fire panel nodes), one network display (either NCA-2 or NCS/ONYXWorks) is required for every system. On network systems, the NCA-2 connects to (and requires) a standard Network Communication Module or High-Speed Network Communication Module. Mounts in a row of FACP node or in two annunciator positions. Mounting options include the DP-DISP2, ADP-4B, or in an annunciator box, such as the ABS-2D. In CAB-4 top-row applications, a DP-DISP2 and two BMP-1 blank modules are required for mounting. Required for NFS2-640 applications employing the DVC-EM with DAL devices. Non-English versions are available. *NCA-2 are available for ULC applications.* For marine applications, order NCA-2-M; for non-English Marine applications, order NCA-2-M and the appropriate KP-KIT-XX. *See DN-7047.*

NCD: As part of a standalone NFS2-640 system, the NCD can serve as Primary Display for the panel, to provide control and status capabilities on displayless nodes. On network systems, the NCD connects to (and requires) a standard Network Communication Module or High-Speed Network Communication Module. Mounting options include the ABS-TD for standalone applications. In the CAB-4 series the NCD can be mounted in the top row with a DP-GDIS1 or lower rows using a DP-GDIS2. *See DN-60974.*

NCA/640-2-KIT: Bracket installation kit required to mount NCA-2 to the CPU2-640/-640E's standard chassis.

DP-DISP2: Dress panel for top row in cabinet with CPU2-640/640E installed.

ADP2-640: Dress panel for middle rows with CPU2-640/640E.

BMP-1: Blank module for unused module positions.

BP2-4: Battery plate, required. *(Existing JADT-XLS-BP2-4 may be used in retrofits.)*

LEM-320: Loop Expander Module. Expands each NFS2-640 to two Signaling Line Circuits. *See DN-6881.*

NETWORKING OPTIONS

NCM-W, NCM-F: Standard Network Communications Modules. Wire and multi-mode fiber versions available. *See DN-6861.*

HS-NCM-W(-2), HS-NCM-MF, HS-NCM-SF, HS-NCM-WMF(-2), HS-NCM-WSF(-2), HS-NCM-MFSF: High-speed Network Communications Modules that can connect to two nodes. Wire, single-mode fiber, multi-mode fiber, and media conversion models are available. See DN-60454.

RPT-W, RPT-F, RPT-WF: Standard-network repeater board with wire connection (RPT-W), multi-mode fiber connection (RPT-F), or allowing a change in media type between wire and fiber (RPT-WF). Not used with high-speed networks. See DN-6971.

ONYXWorks: UL-listed graphics PC workstation, software, and computer hardware. See DN-7048 for specific part numbers.

NFN-GW-EM-3: NFN Gateway, embedded. (Replaces NFN-GW-EM.) See DN-60499.

NWS-3: NOTI•FIRE•NET™ Web Server. See DN-6928.

CAP-GW: Common Alerting Protocol Gateway. See DN-60756.

VESDA-HLI-GW: VESDAnet high-level interface gateway. See DN-60753.

LEDSIGN-GW: UL-listed sign gateway. Interfaces with classic and high-speed NOTI•FIRE•NET networks through the NFN Gateway. See DN-60679.

OAX2-24V: UL-listed LED sign, used with LEDSIGN-GW. See DN-60679.

AUXILIARY POWER SUPPLIES AND BATTERIES

ACPS-610: 6.0 A or 10.0 A addressable charging power supply. See DN-60244.

APS2-6R: Auxiliary Power Supply. Provides up to 6.0 amperes of power for peripheral devices. Includes battery input and transfer relay, and overcurrent protection. Mounts on two of four positions on a CHS-4L or CHS-4 chassis. See DN-5952.

FCPS-24S6/S8: Remote 6 A and 8 A power supplies with battery charger. See DN-6927.

BAT Series: Batteries. NFS2-640 uses two 12 volt, 18 to 200 AH batteries. See DN-6933.

AUDIO OPTIONS

NOTE: For mounting hardware, see “Enclosures, Chassis, and Dress Plates” on page 7 and peripheral data sheets.

DVC-EM: Digital Voice Command, digital audio processor with message storage for up to 32 minutes of standard quality (4 minutes at high quality) digital audio. Capable of playing up to eight simultaneous messages when used with Digital Audio Loop (DAL) devices. See DN-7045.

DVC-RPU: Digital Voice Command Remote Paging Unit for use with DVC-EM. Includes the keypad/display. See DN-60726.

DS-DB: Digital Series Distribution Board, provides bulk amplification capabilities to the DVC-EM while retaining digital audio distribution capabilities. Can be configured with up to four DS-AMPs, supplying high-level risers spread throughout an installation. See DN-60565.

DVC-KD: DVC-EM keypad for local annunciation and controls; status LEDs and 24 user-programmable buttons. See DN-7045.

DS-AMP/E: 125W, 25 VRMS, or 100W, 70VRMS. 70VRMS requires DS-XF70V step-up transformer. Digital Series Amplifier, part of the DS-DB system. See DN-60663.

DS-RFM, DS-FM, DS-SFM: Fiber conversion modules for DVC-EM, DS-DB distribution board, and DAX and DAA2 Series amplifiers. See DN-60633.

DVC-AO: DVC Analog Output board provides four analog output circuits for use with AA Series amplifiers. Four-channel operation supported. See DN-7045.

DAA2-5025(E): 50W, 25 Vrms Digital Audio Amplifier assembly with power supply; includes chassis. See DN-60556.

DAA2-5070(E): 50W, 70.7 Vrms Digital Audio Amplifier assembly with power supply; includes chassis. See DN-60556.

DAA2-7525(E): 75W, 25 Vrms digital audio amplifier assembly with power supply; includes chassis. See DN-60556.

DAX-3525(E): 35W, 25 Vrms Digital Audio Amplifier assembly with power supply, includes chassis. See DN-60561.

DAX-3570(E): 35W, 70.7 Vrms Digital Audio Amplifier assembly with power supply, includes chassis. See DN-60561.

DAX-5025(E): 50W, 25 Vrms Digital Audio Amplifier assembly with power supply, includes chassis. See DN-60561.

DAX-5070(E): 50W, 70.7 Vrms Digital Audio Amplifier assembly with power supply, includes chassis. See DN-60561.

TELH-1: Firefighter’s Telephone Handset for use with the DVC-EM when mounted in the CA-2 chassis. See DN-7045.

CMIC-1: Optional microphone and microphone well assembly used with the CA-1 chassis.

RM-1/RM-1SA: Remote microphone assemblies, mount on ADP-4 (RM-1) dress panel or CAB-RM/-RMR (RM-1SA) stand-alone cabinets. See DN-6728.

AA-30: Audio Amplifier, 30 watts, 25 Vrms. Includes amplifier and audio input supervision, backup input, and automatic switchover, power supply, cables. See DN-3224.

AA-120/AA-100: Audio Amplifier provides up to 120 watts of 25 VRMS audio power for the NFS-640. The amplifier contains an integral chassis for mounting to a CAB-B4, -C4, or -D4 backbox (consumes one row). Switch-mode power. Includes audio input and amplified output supervision, backup input, and automatic switchover to backup tone. Order the AA-100 for 70.7 VRMS systems and 100 watts of power. See DN-3224.

DAA Series Digital Audio Amplifiers: Legacy DAA Series amplifiers are compatible with DVC-EM systems running SR4.0. For specific information on DAA-50 series amplifiers, refer to DN-7046. For information on DAA-7525 Series, refer to DN-60257.

NFC-25/50: 25 watt, 25 VRMS, emergency Voice Evacuation Control Panel (VECP) with integral commercial microphone, digital message generator, and single-/dual-channel Class A or Class B speaker circuits. See DN-60772.

COMPATIBLE DEVICES, EIA-232 PORTS

PRN-7: 80-column printer. See DN-60897.

VS4095/5: Printer, 40-column, 24V. Mounted in external backbox. See DN-3260.

DPI-232: Direct Panel Interface, specialized modem for extending serial data links to remotely located FACPs and/or peripherals. See DN-6870.

COMPATIBLE DEVICES, EIA-485 PORTS

ACM-24AT: ONYX Series ACS annunciator – up to 96 points of annunciation with Alarm or Active LED, Trouble LED, and switch per circuit. Active/Alarm LEDs can be programmed (by powered-up switch selection) by point to be red, green, or yellow; the Trouble LED is always yellow. See DN-6862.

AEM-24AT: Same LED and switch capabilities as ACM-24AT, expands the ACM-24AT to 48, 72, or 96 points. See DN-6862.

ACM-48A: ONYX Series ACS annunciator – up to 96 points of annunciation with Alarm or Active LED per circuit. Active/Alarm LEDs can be programmed (by powered-up switch selection) in groups of 24 to be red, green, or yellow. Expandable to 96 points with one AEM-48A. See DN-6862.

AEM-48A: Same LED capabilities as ACM-48A, expands the ACM-48A to 96 points. See DN-6862.

ACM-8R: Remote Relay Module with eight Form-C contacts. Can be located up to 6,000 ft. (1828.8 m) from panel on four wires. See DN-3558.

FDU-80: Terminal mode. 80-character, backlit LCD display. Mounts up to 6,000 ft. (1828.8 m) from panel. Up to 32 per FACP. See DN-6820.

LCD2-80: Terminal and ACS mode. 80-character, backlit LCD display. Mounts up to 6,000 ft. (1828.8 m) from panel. Up to 32 per FACP. See *DN-60548*.

LDM: Lamp Driver Modules LDM-32, LDM-E32, and LDM-R32; remote custom graphic driver modules. See *DN-0551*.

SCS: Smoke control stations SCS-8, SCE-8, with lamp drivers SCS-8L, SCE-8L; eight (expandable to 16) circuits (HVAC only). See *DN-4818*.

TM-4: Transmitter Module. Includes three reverse-polarity circuits and one municipal box circuit. Mounts in panel module position (single-address-style) or in CHS2-M2 position. See *DN-6860*.

UDACT-2: Universal Digital Alarm Communicator Transmitter, 636 channel. See *DN-60686*.

UZC-256: Programmable Universal Zone Coder provides positive non-interfering successive zone coding. Microprocessor-controlled, field-programmable from IBM®-compatible PCs (requires optional programming kit). Up to 256 programmable codes. Mounts in **BB-UZC** or other compatible chassis (purchased separately). See *DN-3404*.

COMPATIBLE INTELLIGENT DEVICES

NOTE: "A" suffix indicates ULC-Listed model.

FWSG Wireless SWIFT Gateway: Addressable gateway supports wireless SLC devices. Not appropriate for ULC applications. See *DN-60820*.

FCO-951/IV FlashScan, Addressable intelligent multi-criteria smoke sensors, photo, carbon monoxide, fixed temperature heat detector and infra-red (IR). ULC: FCO-951A/IV

FPC-951. FlashScan, Combined photoelectric and carbon monoxide sensor. ULC: FPC-951A.

FSCO-951. FlashScan, Addressable carbon monoxide sensor. ULC: FSCO-951A.

FPTI-951, FPTI-951-IV: Addressable intelligent multi-criteria photoelectric, thermal and IR sensors. ULC: FPTI-951A, FPTI-951A-IV.

FS-OSI-RIAddressable intelligent single-ended beam smoke detector. ULC: FS-OSI-RIA.

FSP-951: White, low-profile intelligent photoelectric sensor, FlashScan only. ULC: FSP-951A.

FSP-951-IV: Ivory, low-profile intelligent photoelectric sensor. ULC: FSP-951A-IV

FSP-951T: White, same as FSP-951 but includes a built-in 135°F (57°C) fixed-temperature thermal device. FlashScan only. ULC: FSP-951TA.

FSP-951T-IV: Ivory, same as FSP-951T but includes a built-in 135°F (57°C) fixed-temperature thermal device. ULC: FSP-951TA-IV.

FSP-951R: White, low-profile intelligent photoelectric sensor, remote test capable. For use with DNR/DNRW. FlashScan only. ULC: FSP-95RA

FSP-951R-IV: Ivory, low-profile intelligent photoelectric sensor, remote test capable. FlashScan only. ULC: FSP-95RA-IV, for use with DNRA.

FST-951: White, low-profile intelligent 135°F fixed thermal sensor, FlashScan only. Must be mounted to one of the bases listed below. ULC: FST-951A. See *DN-60975*.

FST-951-IV: Ivory, low-profile intelligent 135°F fixed thermal sensor, FlashScan and CLIP. Must be mounted to one of the bases listed below. ULC: FST-951A-IV.

FST-951R: White, low-profile intelligent rate-of-rise thermal sensor, FlashScan only. Must be mounted to one of the bases listed below. ULC: FST-951A

FSP-951R-IV: Ivory, low-profile intelligent photoelectric sensor, remote test capable. FlashScan only. ULC: FSP-95RA-IV, for use with DNRA.

FST-951H: White, low-profile intelligent 190°F fixed thermal sensor, FlashScan only. Must be mounted to one of the bases listed below. ULC: FST-951HA.

FST-951H-IV: Ivory, low-profile intelligent 190°F thermal sensor, FlashScan and CLIP. Must be mounted to one of the bases listed below. ULC: FST-951HA-IV.

FSV-951, FSV-951R:White, intelligent high-sensitivity photoelectric smoke detector. ULC: FSV-951A, FSV-951RA

FSV-951-IV, FSV-951R-IVIvory, intelligent high-sensitivity photoelectric smoke detector. ULC: FSV-951A-IV, FSV-951RA-IV.

VEP-A00-P-NTF: Intelligent aspiration smoke detector with LED display, 4 pipes, covers up to 21,520 square feet. See *DN-61029*. UL/ULC Listed.

VEP-A10-P-NTF: Intelligent aspiration smoke detector with LED and LCD display, 4 pipes, covers up to 21,520 square feet. See *DN-61029*. UL/ULC Listed.

VEP-A00-1P-NTF: Intelligent aspiration smoke detector with LED display, single pipe, covers up to 10,760 square feet. See *DN-61029*. UL/ULC Listed.

VEU-A00-NTF: Intelligent aspiration smoke detector with LED display, 4 pipes, covers up to 69,965 square feet. See *DN-61034*. UL/ULC Listed.

VEU-A10-NTF: Intelligent aspiration smoke detector with LED and LCD display, 4 pipes, covers up to 69,965 square feet. See *DN-61034*. UL/ULC Listed.

VEA-040-A00-NTF: Intelligent aspiration with LED display, 40 point-addressable detection points. Covers 36,000 square feet. See *DN-61036*. UL/ULC Listed.

VEA-040-A10-NTF: Intelligent aspiration with LED and LCD display, 40 point-addressable detection points. Covers 36,000 square feet. See *DN-61036*. UL/ULC Listed.

DNR: InnovairFlex low-flow non-relay duct-detector housing. ULC: DNRA. (Order FSP-951R(A) separately.) See DN-60429.

DNRW: Same as above with NEMA-4 rating, watertight. See DN-60429.

B224RB-WH: White, low-profile relay base. See *DN-60054*. ULC: B224RBA-WH.

B224RB-IV: Ivory, plug-in System Sensor relay base. ULC: B224RBA-IV.

B224BI-WH: White, isolator base for low-profile detectors. See *DN-60054*. ULC: B224BIA-WH.

B224BI-IV: Ivory isolator detector base. ULC: B224BIA-IV.

B300-6: White, standard flanged low-profile mounting base. (For 10-pack order B300-6-BP.) ULC: B300A-6.

B300-6-IV: Ivory, standard flanged low-profile mounting base. ULC: B300A-6-IV.

B501-WHITE: European-style, 4" (10.16 cm) base. See *DN-60054*. (For 10-pack order B501-WHITE-BP.) UL/ULC listed.

B501-BL: Black, 4" standard European flangeless mounting base. UL/ULC listed.

B501-IV: Ivory color, 4" standard European flangeless mounting base. UL/ULC listed.

B200S-WH: White, intelligent programmable sounder base, capable of producing a variety of tone patterns including ANSI Temporal 3. Compatible with synchronization protocol. See DN-60054. ULC: B200SA-WH.

B200S-IV: Ivory intelligent, programmable sounder base. ULC: B200SA-IV.

B200SCOA-WH: White intelligent, programmable sounder base in English/French (required in Canada for ULC applications with CO detectors. Based on B200SA. ULC listed.

B200SCOA-IV: Ivory intelligent, programmable sounder base in English/French (required in Canada for ULC applications with CO detectors). Based on B200SA. ULC listed.

B200S-LF-WH: White, low-frequency version of B200S. See DN-60054.

B200S-LF-IV: Ivory, low-frequency version of B200S.

B200SR-WH: White intelligent programmable sounder base, Temporal 3 or Continuous tone. For retrofit installations replacing B501BH series bases. See DN-60054. ULC: B200SRA-WH.

B200SR-IV: Ivory intelligent programmable sounder base, Temporal 3 or Continuous tone. For retrofit installations replacing B501BH series bases. ULC: B200SRA-IV.

B200SR-LF-WH: White, low-frequency version of B200SR. See DN-60054.

B200SR-LF-IV: Ivory, low-frequency version of B200SR.

FMM-1(A): FlashScan monitor module. See DN-6720.

FDM-1(A): FlashScan dual monitor module. See DN-6720.

FZM-1(A): FlashScan two-wire detector monitor module. See DN-6720.

FMM-101(A): FlashScan miniature monitor module. See DN-6720.

FTM-1(A): Firephone Telephone Module connects a remote firefighter telephone to a centralized telephone console. Reports status to panel. Wiring to jacks and handsets is supervised. See DN-6989.

FCM-1(A): FlashScan control module. See DN-6720.

FCM-1-REL(A): FlashScan releasing control module. See DN-60390.

FRM-1(A): FlashScan relay module. See DN-6720.

FDRM-1(A): FlashScan dual monitor/dual relay module. See DN-60709.

NBG-12LX: Manual pull station, addressable. See DN-6726.

N-MPS series: Manual pull stations, addressable and conventional. For use in Canada only. See DN-5497 and DN-60629.

ISO-X(A): Isolator module. See DN-2243.

ISO-6(A): Six fault isolator module. See DN-60844.

XP6-C(A): FlashScan six-circuit supervised control module. See DN-6924.

XP6-MA(A): FlashScan six-zone interface module; connects intelligent alarm system to two-wire conventional detection zone. See DN-6925.

XP6-R(A): FlashScan six-relay (Form-C) control module. See DN-6926.

XP10-M(A): FlashScan ten-input monitor module. See DN-6923.

ENCLOSURES, CHASSIS, AND DRESS PLATES

CAB-4 Series Enclosure: NFS2-640 mounts in a standard CAB-4 Series enclosure (available in four sizes, "A" through "D"). Backbox and door ordered separately; requires BP2-4 battery plate. A trim ring option is available for semi-flush mounting. See DN-6857.

EQ Series Cabinets: EQ series cabinets will house amplifiers, power supplies, battery chargers and control modules. EQ cabinets are available in three sizes, "B" through "D". See DN-60229.

CAB-BM Marine System: Protects equipment in shipboard and waterfront applications. Also order **BB-MB** for systems using 100 AH batteries. For a full list of required and optional equipment, see DN-60688.

CHS-4: Chassis for mounting up to four APS-6Rs.

CHS-4L: Low-profile four-position Chassis. Mounts two AA-30 amplifiers or one AMG-E and one AA-30.

DP-1B: Blank dress panel. Provides dead-front panel for unused tiers; covers DAA2/DAX series or AA-series amplifier.

NFS-LBB: Battery Box (required for batteries larger than 26 AH).

NFS-LBBR: Same as above but red.

CHS-BH1: Battery chassis; holds two 12.0 AH batteries. Mounts one the left side of DAA2 chassis. See DN-7046.

CA-1: Chassis, occupies one tier of a CAB-4 Series enclosure. The left side accommodates one DVC-EM and a DVC-KD (optional); and the right side houses a CMIC-1 microphone and its well (optional). See DN-7045.

CA-2: Chassis assembly, occupies two tiers of a CAB-4 Series enclosure. The left side accommodates one DVC-EM mounted on a half-chassis and one NCA-2 mounted on a half-chassis. The right side houses a microphone/handset well. The CA-2 assembly includes CMIC-1 microphone. ADDR Series doors with two-tier visibility are available for use with the CA-2 configuration: ADDR-B4, ADDR-C4, ADDR-D4 (below).

CFFT-1: Chassis to mount firefighter's telephone and one ACS annunciator in a CAB-4 row. Includes TELH-1 firefighter's handset for the DVC-EM, chassis, phone well and mounting hardware. Order DP-CFFT dress panel separately.

DP-CFFT: CFFT-1 dress panel. Requires BMP-1 if no ACS annunciator is installed.

ADDR-B4*: Two-tier-sized door designed for use with the CA-2 chassis configuration. ADDR Series doors are similar to CAB-4 Series "DR" doors, but a clear window space exposes the top two tiers of the CAB-4 enclosure. Use an SBB-B4 backbox with the ADDR-B4. See DN-7045, DN-6857.

ADDR-C4*: Three-tier-sized door, designed for use with the CA-2 chassis configuration. ADDR Series doors are similar to CAB-4 Series "DR" doors, but a clear window space exposes the top two tiers of the CAB-4 enclosure. Use an SBB-C4 backbox with the ADDR-C4. See DN-7045, DN-6857.

ADDR-D4*: Four-tier-sized door designed for use with the CA-2 chassis configuration. ADDR Series doors are similar to CAB-4 Series "DR" doors, but a clear window space exposes the top two tiers of the CAB-4 enclosure. Use an SBB-D4 backbox with the ADDR-D4. See DN-7045, DN-6857.

* Note: Use ADDR-B4/C4/D4 when CA-2 chassis is installed in top two rows with NCA-2 or BP-CA2. Use standard door when CA-2 is not installed in top two rows. For additional configuration information, see the DVC application guide on <http://esd.notifier.com>.

DPA-1: Dress panel, used with the CA-1 chassis when configured with a DVC-EM, DVC-KD, and CMIC-1. See DN-7045.

DPA-2B: Dress panel used with CA-2 chassis assembly.

VP-2B: Dress panel, required when CA-2 chassis is installed in the top two cabinet rows.

DPA-1A4: Dress panel, used with the CA-1 chassis when the CMIC-1 is not used. Provides mounting options on right two bays for two ACS annunciators, or for blank plates. See DN-7045.

BP-CA2: Blank plate for CA-2 chassis.

SEISKIT-CAB: Seismic mounting kit. Required for seismic-certified applications with NFS2-640 and other equipment mounted in CAB-4 Series Enclosures. Includes battery bracket for two 26 AH batteries.

SEISKIT-LBB: Seismic kit for the NFS-LBB. Includes battery bracket for two 55 AH batteries.

BACKBOXES

NOTE: "C" suffix indicates ULC-Listed model.

ABF-1B(C) Annunciator Flush Box.

ABF-1DB(C) Annunciator Flush Box with Door.

ABF-2B Annunciator Flush Box

ABF-2DB/C Annunciator Flush Box with Door

ABF-4B Annunciator Flush Box

ABS-1TB(C) Annunciator Surface Box

ABS-1B(C) Annunciator Surface Box

ABS-2B Annunciator Surface Box

ABS-2D(C) Annunciator Surface Box

ABS-4D(C) Annunciator Surface Box

BB-UZC: Backbox for housing the UZC-256 in applications where the UZC-256 will not fit in panel enclosure. Black; for red, order BB-UZC-R.

OTHER OPTIONS

411: Slave digital alarm communicator. See DN-6619.

411UDAC: Digital alarm communicator. See DN-6746.

IPDACT-2/2UD, IPDACT Internet Monitoring Module: Connects to primary and secondary DACT telephone output ports for internet communications over customer-provided Ethernet connection. Requires compatible Teldat VisorALARM Central Station Receiver. Can use DHCP or static IP. See DN-60408.

IPCHSKIT: IP Communicator Chassis Mounting Kit. For mounting an IPDACT-2/2UD onto the panel chassis or CHS-4 series chassis. Use IPENC for external mounting applications.

IPSPLT: Y-adaptor option allow connection of both panel dialer outputs to one IPDACT-2/2UD cable input.

IPENC: External enclosure for IPDACT, includes IPBRKT mounting bracket; Red. For Black order IPENC-B.

HWF2V-COM: LTE Digital Cellular Fire Alarm Communicator and Internet Panel, Verizon LTE / IP. Provides selectable configurable paths: cellular only, IP only, or IP primary with cellular backup. Connects to the primary and secondary ports of a DACT. See DH-62010. (For Canadian applications order IPGSM-4GC. See DH-60771.)

HWF2A-COM: LTE Digital Cellular Fire Alarm Communicator and Internet Panel, AT&T LTE / IP. Provides selectable configurable paths: cellular only, IP only, or IP primary with cellular backup. Connects to the primary and secondary ports of a DACT. (For Canadian applications order IPGSM-4GC. See DH-60771.)

NOTE: For other options including compatibility with retrofit equipment, refer to the panel's installation manual, the SLC manual, and the Device Compatibility Document.

SPECIFICATIONS

SYSTEM CAPACITY

- Intelligent Signaling Line Circuits 1 expandable to 2
- Intelligent detectors 159 per loop
- Addressable monitor/control modules 159 per loop
- Programmable software zones 99
- Special programming zones 14
- LCD annunciators per CPU2-640/-640E and NCA-2 (*observe power*) 32
- ACS annunciators per CPU2-640/-640E 32 addresses x 64 points
- ACS annunciators per NCA-2 32 addresses x 64 or 96 points

NOTE: The NCA-2 supports up to 96 annunciator address points per ACM-24AT/-48A.

ELECTRICAL SPECIFICATIONS

- Primary input power:
 - CPU2-640 board: 120 VAC, 50/60 Hz, 5.0 A.
 - CPU2-640E board: 220/240 VAC, 50/60 Hz, 2.5 A.
- Current draw (standby/alarm):
 - CPU2-640(E) board: 0.250 A. Add 0.035 A for each NAC in use.
 - KDM-R2: 0.100 A.
 - LEM-320: 0.100 A.
- Total output 24 V power: 6.0 A in alarm.

NOTE: The power supply has a total of 6.0 A. of available power. This is shared by all internal circuits. See Installation Manual for a complete current draw calculation sheet.

- Standard notification circuits (4): 1.5 A each.
- Resettable regulated 24V power: 1.25 A.
- Two non-resettable regulated 24V power outputs:
 - 1.25 A.
 - 0.50 A.
- Non-resettable 5V power: 0.15 A.
- Battery charger range: 18 AH – 200 AH. Use separate cabinet for batteries over 26 AH.
- Float rate: 27.6 V.

CABINET SPECIFICATIONS

- Systems can be installed in CAB-4 Series cabinets (*four sizes with various door options, see DN-6857*). Requires BP2-4 Battery Plate.

SHIPPING WEIGHT

- CPU2-640/-640: 14.3 lb (6.49 kg).
- CPU2-640/-640E: 14.55 lb (6.60 kg).

TEMPERATURE AND HUMIDITY RANGES

This system meets NFPA requirements for operation at 0 – 49°C/32 – 120°F and at a relative humidity 93% ± 2% RH (noncondensing) at 32°C ± 2°C (90°F ± 3°F). However, the useful life of the system's standby batteries and the electronic components may be adversely affected by extreme temperature ranges and humidity. Therefore, it

is recommended that this system and its peripherals be installed in an environment with a normal room temperature of 15 – 27°C/60 – 80°F.

AGENCY LISTINGS AND APPROVALS

The listings and approvals below apply to the basic NFS2-640 control panel. In some cases, certain modules may not be listed by certain approval agencies, or listing may be in process. Consult factory for latest listing status.

- **UL/ULC Listed:** S635.
- **ULC Listed:** S527-11
- **FM Approved.**
- **MEA:** 128-07-E.
- **Fire Dept. of New York:** #6212.
- **CSFM:** 7165-0028:0243.
- **City of Chicago.**
- **City and County of Denver.**
- **CCCF listed.**

Marine Applications: Marine approved systems must be configured using components itemized in this document. (See Main System Components, in "Product Line Information.") Specific connections and requirements for those components are described in the installation document, PN 54756. When these requirements are followed, systems are approved by the following agencies:

- **US Coast Guard** 161.002/50/0, 161.002/55/0 (Standard 46 CFR and 161.002).
- **Lloyd's Register** 11/600013 (ENV 3 category).
- **American Bureau of Shipping (ABS)** Type Approval.

NOTE: For information on marine applications, see DN-60688.

STANDARDS

The NFS2-640 complies with the following UL Standards and NFPA 72, International Building Code (IBC), and California Building Code (CBC) Fire Alarm Systems requirements:

- **UL 864, 9th Edition (Fire).**
- **UL 1076 (Burglary).**
- **UL 2572 (Mass Notification Systems).** (NFS2-640 version 20 or higher.)
- **ULC-S527-11** Standard for the Installation of Fire Alarm Systems.
- **LOCAL** (Automatic, Manual, Waterflow and Sprinkler Supervisory).
- **AUXILIARY** (Automatic, Manual and Waterflow) (requires TM-4).
- **REMOTE STATION** (Automatic, Manual, Waterflow and Sprinkler Supervisory) (requires TM-4).
- **PROPRIETARY** (Automatic, Manual and Waterflow). *Not applicable for FM.*
- **EMERGENCY VOICE/ALARM.**
- **OT, PSDN** (Other Technologies, Packet-switched Data Network).
- **IBC 2012, IBC 2009, IBC 2006, IBC 2003, IBC 2000** (Seismic).
- **CBC 2007** (Seismic).



This document is not intended to be used for installation purposes.
We try to keep our product information up-to-date and accurate.
We cannot cover all specific applications or anticipate all requirements.
All specifications are subject to change without notice.

NOTIFIER

12 Clintonville Road
Northford, CT 06472
203.484.7161
www.notifier.com

NOTIFIRE[®]NET[™], ONYXWorks[™], and SWIFT[™] are all trademarks of and FlashScan[®], NOTIFIER[®], ONYX[®], VeriFire[®] Tools, and VIEW[®] are all registered trademarks of Honeywell International Inc.
©2019 by Honeywell International Inc. All rights reserved. Unauthorized use of this document is strictly prohibited.

Country of Origin: USA



CAB-4 Series Cabinets

ONYX® Series Backboxes with Locking Doors



Peripheral Devices

General

All cabinets for NOTIFIER fire alarm control panels are fabricated from 16-gauge steel. The cabinet assembly consists of two basic parts: a backbox and a locking door. Cabinets are available in either black or red, with or without windows. The window model provides a tasteful combination to accent the decor of the finest lobby setting.

- The **key-locked door** is provided with a pin-type hinge, two keys and the necessary hardware to mount the door to the backbox.
- The **backbox** has been engineered to provide ease-of-entry for the installer. **Knockouts** are positioned at numerous points to aid the installer in bringing a conduit into the enclosure with a minimum of hardship.
- **Right- or left-hand hinges**, selectable in the field. Door opens 180°.
- Cabinets are arranged in **four standard sizes**, A (one tier) through D (four tiers), plus a **mini cabinet** (AA, one tier without a battery compartment). See *Ordering Information*.
- A **trim ring option** is available for semi-flush mounting.
- **Chassis bridge** available for assembling multiple CHS-4 chassis external to the backbox.
- Certified for seismic applications when used with the appropriate **seismic mounting kit**.

Ordering Information

A complete cabinet assembly consists of: a door, a backbox, an optional battery plate, and an optional semi-flush trim ring. For each cabinet required, order one "DR" door and one "SBB" backbox. The BP2-4 battery plate is required for each cabinet assembly that mounts batteries and/or a power supply in the lower position of the cabinet. The optional trim ring is an attractive "picture frame"-style black metal ring.

MINI "AA" SIZE, ONE TIER

DR-AA4: Door assembly, window, one tier (no battery compartment), BLACK, 9.8 lbs.

DR-AA4R: Door assembly, window, one tier (no battery compartment), RED, 9.8 lbs.

DR-AA4B: Door assembly, solid door, one tier (no battery compartment), BLACK.

DR-AA4BR: Door assembly, solid door, one tier (no battery compartment), RED.

SBB-AA4: Backbox assembly, one tier (no battery compartment), BLACK, 16.65 lbs.

SBB-AA4R: Backbox assembly, one tier (no battery compartment), RED, 16.65 lbs.

TR-AA4: Accessory semi-flush-mount trim ring, one tier (no battery compartment).

NOTE: Black trim rings are used with red or black cabinets.

ONE TIER, "A" SIZE

DR-A4: Door assembly, window, one tier, BLACK, 14.20 lbs.

DR-A4R: Door assembly, window, one tier, RED, 14.20 lbs.

DR-A4B: Door assembly, solid door, one tier, BLACK, 14.30 lbs.

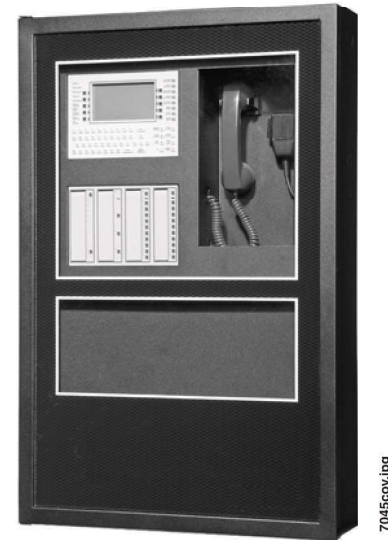

NFS2-3030 and DVC in "C" sized CAB-4 cabinet

DR-A4BR: Door assembly, solid door, one tier, RED, 15 lbs.

SBB-A4: Backbox assembly, one tier, BLACK, 21 lbs.

SBB-A4R: Backbox assembly, one tier, RED, 21 lbs.

TR-A4: Accessory semi-flush-mount trim ring, one tier (opening 24.062" [61.118 cm] W x 20.062" [50.958 cm] H), BLACK, 2.5 lbs.

NOTE: Black trim rings are used with red or black cabinets.

BP2-4: Battery plate. Used to cover battery and power supply when lower position is used in backbox, 3.10 lbs.

TWO TIERS, "B" SIZE

DR-B4: Door assembly, window, two tiers, BLACK, 17.45 lbs.

DR-B4R: Door assembly, window, two tiers, RED, 17.45 lbs.

ADDR-B4: Two-tier-sized door designed for use with a CA-2 chassis mounted in the top rows. BLACK.

ADDR-B4R: Two-tier-sized door designed for use with a CA-2 chassis mounted in the top rows. RED.

DR-B4B: Door assembly, solid door, two tiers, BLACK, 18.80 lbs.

DR-B4BR: Door assembly, solid door, two tiers, RED, 18.80 lbs.

SBB-B4: Backbox assembly, two tiers, BLACK, 26.88 lbs.

SBB-B4R: Backbox assembly, two tiers, RED, 26.88 lbs.

TR-B4: Accessory semi-flush-mount trim ring, two tiers (opening 24.062" [61.118 cm] W x 28.562" [72.548 cm] H), BLACK, 3 lbs.

NOTE: Black trim rings are used with red or black cabinets.

BP2-4: Battery plate. Used to cover battery and power supply when lower position is used in backbox, 3.10 lbs.

THREE TIERS, "C" SIZE

DR-C4: Door assembly, window, three tiers, BLACK, 20.75 lbs.

DR-C4R: Door assembly, window, three tiers, RED, 20.75 lbs.

ADDR-C4: Three-tier-sized door designed for use with a CA-2 chassis mounted in the top rows. BLACK.

ADDR-C4R: Three-tier-sized door designed for use with a CA-2 chassis mounted in the top rows. RED.

DR-C4B: Door assembly, solid door, three tiers, BLACK, 23.45 lbs.

DR-C4BR: Door assembly, solid door, three tiers, RED, 23.45 lbs.

SBB-C4: Backbox assembly, three tiers, BLACK, 32.60 lbs.

SBB-C4R: Backbox assembly, three tiers, RED, 32.60 lbs.

TR-C4: Accessory semi-flush-mount trim ring, three tiers (opening 24.062" [61.118 cm] W x 37.187" [94.455 cm] H), BLACK, 3.50 lbs.

NOTE: Black trim rings are used with red or black cabinets.

BP2-4: Battery plate. Used to cover battery and power supply when lower position is used in backbox, 3.10 lbs.

FOUR TIERS, "D" SIZE

DR-D4: Door assembly, window, four tiers, BLACK, 23.95 lbs.

DR-D4R: Door assembly, window, four tiers, RED, 23.95 lbs.

ADDR-D4: Four-tier-sized door designed for use with a CA-2 chassis mounted in the top rows. BLACK.

ADDR-D4R: Four-tier-sized door designed for use with a CA-2 chassis mounted in the top rows. RED.

DR-D4B: Door assembly, solid door, four tiers, BLACK, 28.40 lbs.

DR-D4BR: Door assembly, solid door, four tiers, RED, 28.40 lbs.

SBB-D4: Backbox assembly, four tiers, BLACK, 40 lbs.

SBB-D4R: Backbox assembly, four tiers, RED, 40 lbs.

TR-D4: Accessory semi-flush-mount trim ring, four tiers (opening 24.062" [61.118 cm] W x 45.812" [116.363 cm] H), BLACK, 3.80 lbs.

NOTE: Black trim rings are used with red or black cabinets.

BP2-4: Battery plate. Used to cover battery and power supply when lower position is used in backbox, 3.10 lbs.

ACCESSORIES

ADP-4B: Annunciator dress panel.

CAB-BM: For use with "B" sized cabinets in Marine applications. See DN-60688 for more information.

CB-1: Chassis bridge. Provides a bridge between CHS Series chassis.

DP-1B: Blank dress panel, covers one CAB-4 tier, BLACK.

SEISKIT-CAB: Seismic mounting kit. Required for seismic-certified applications with NFS2-3030, NFS2-640, and NFS-320SYS. Includes battery bracket for two 26 AH batteries.

VP-2B: Ventilator panel.

WC-2: Wire channel. Provides a pair of wire trays to neatly route wiring between CHS chassis.

- **UL** Listed: S635
- **ULC** Listed: S635
- **MEA:** 317-01-E, 345-02-E
- **CSFM:** 7165-0028:0243 (NFS2-640), 7165-0028:0224 (NFS2-3030)
- **FM** approved
- **FDNY:** COA# 6085, COA# 6098

CAB-4 Series cabinets with SEISKIT-CAB comply with seismic requirements of **IBC 2000, IBC 2003, IBC 2006, IBC2009,** and **CBC 2007.**

Agency Listings and Approvals

These listings and approvals below apply to the CAB-4 Series Cabinets. In some cases, certain modules or applications may not be listed by certain approval agencies, or listing may be in process. Consult factory for latest listing status.

Cabinet Dimensions and Features

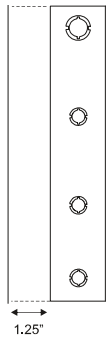

Height of mounting bolt after installation

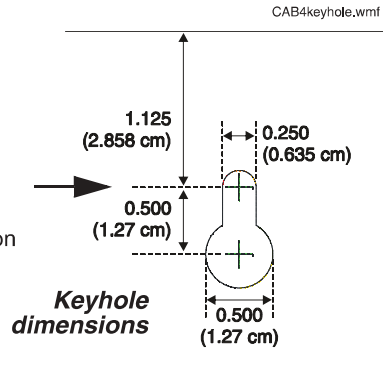

CAB4keyhole.wmf

Knockouts on top of cabinets.

KNOCKOUTS:
 Inner: 0.875" (2.223)
 Outer: 1.125" (2.858)

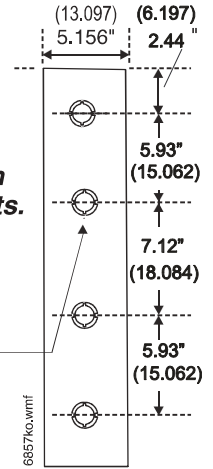

6857/ko.wmf

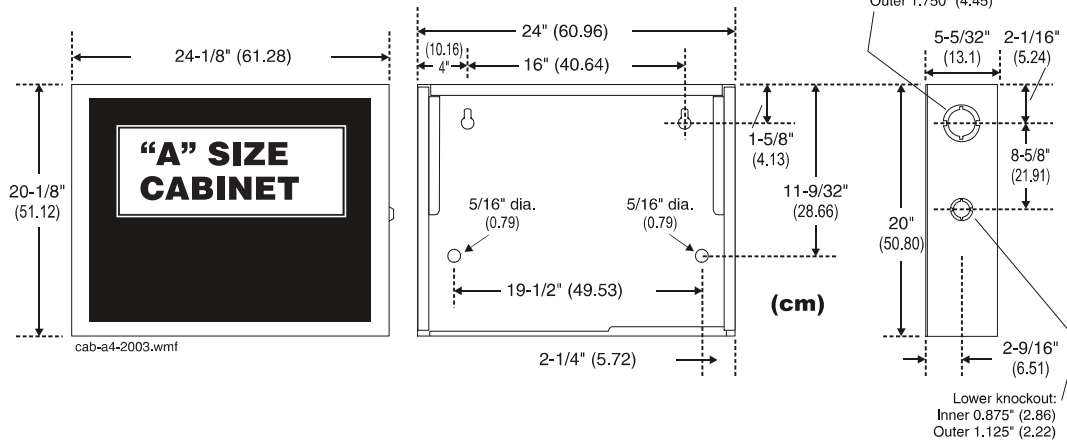

cab-a4-2003.wmf

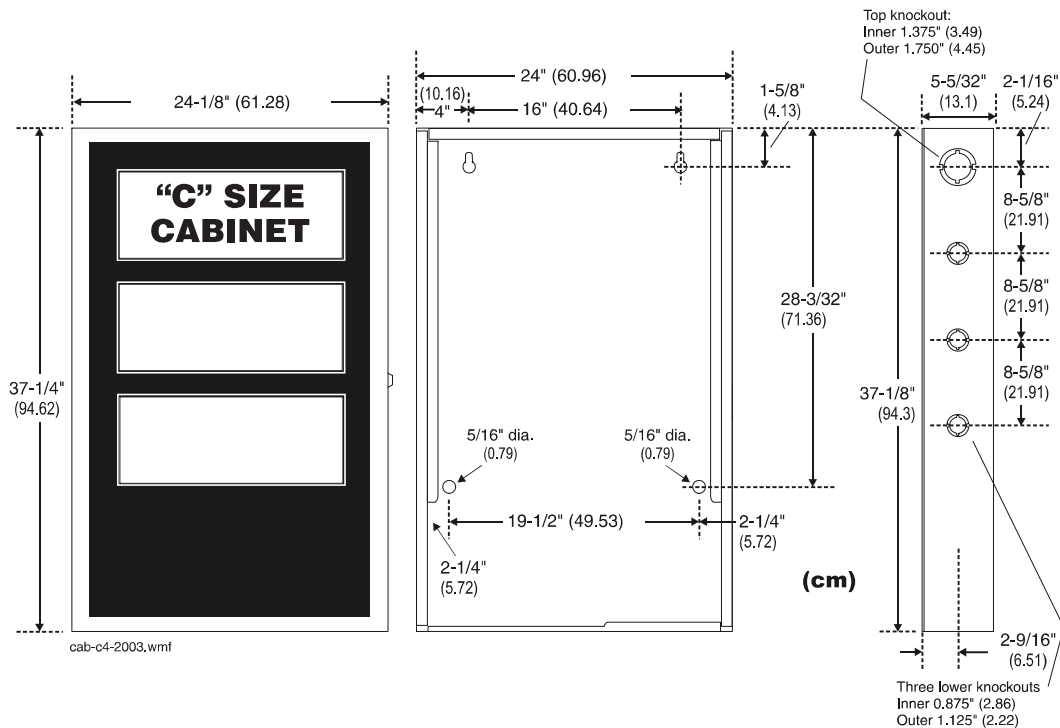
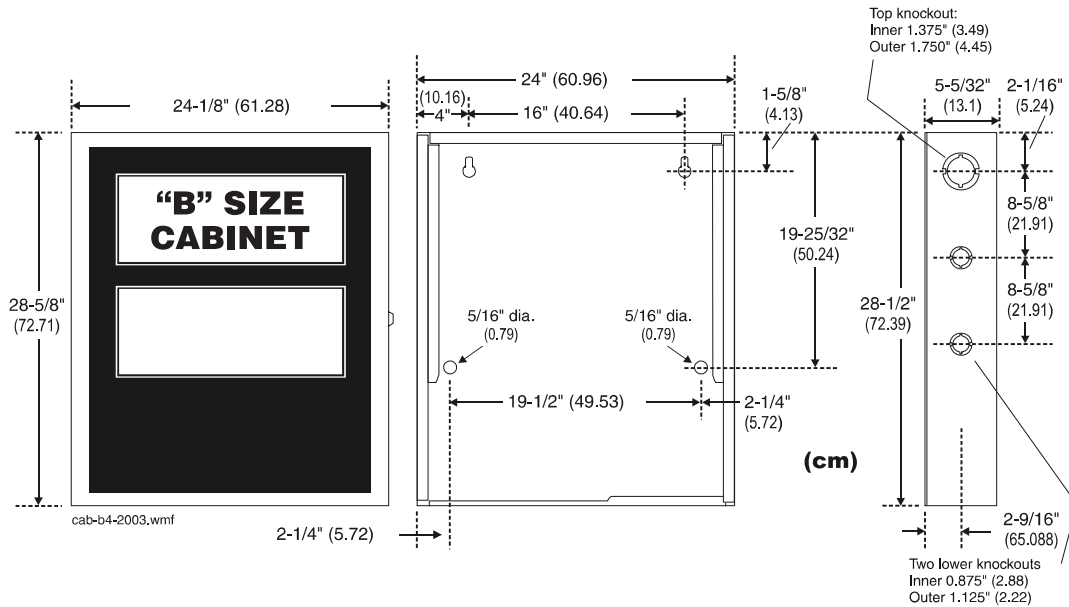
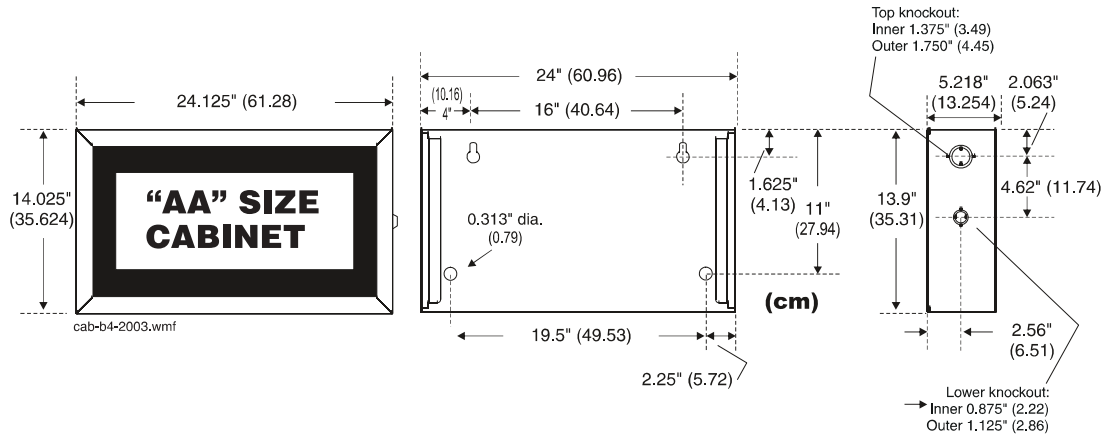

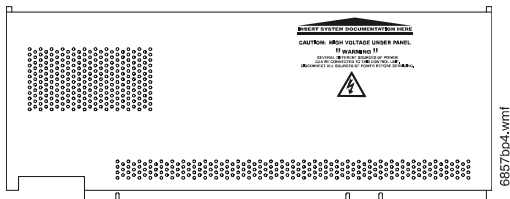
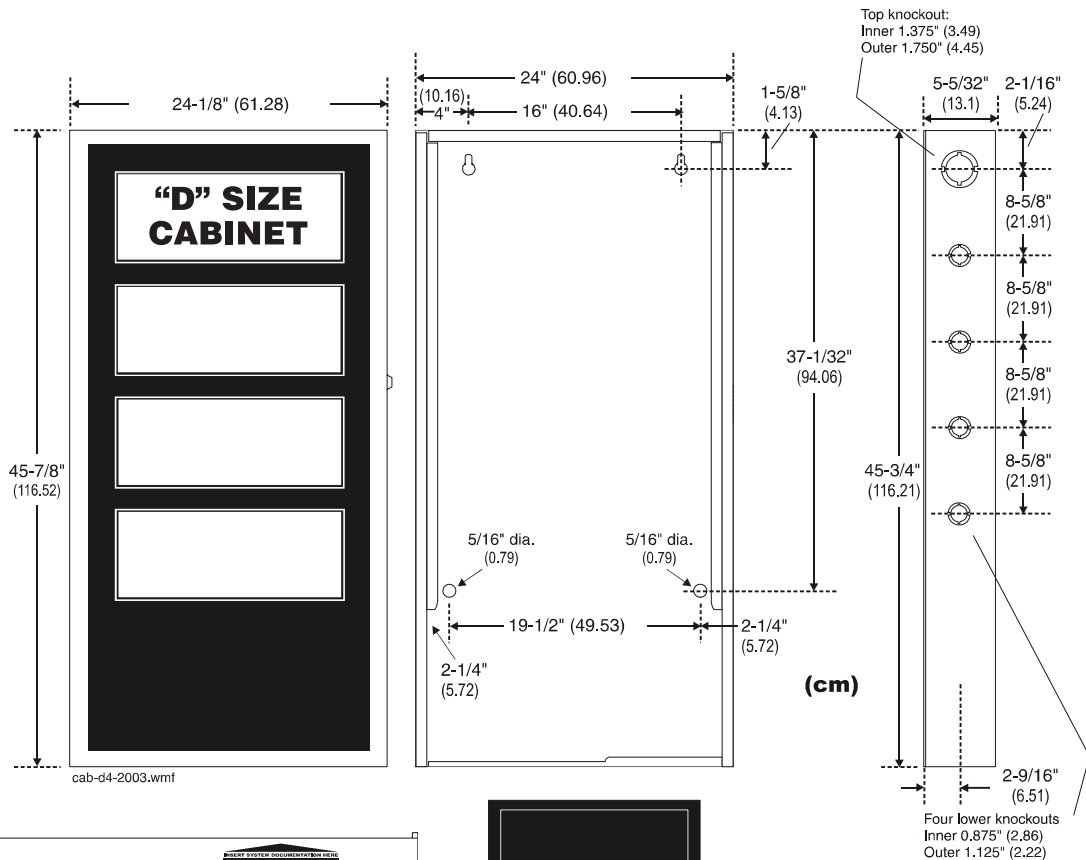

The BP2-4 Battery Plate covers the Main Power Supply and the batteries in the cabinet. Only one BP2-4 is required per cabinet unless an AA cabinet is used (no battery compartment).

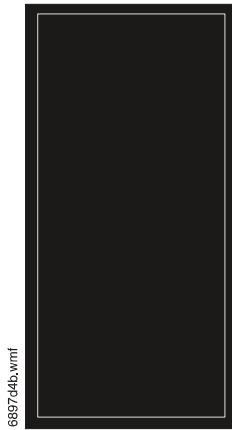

"D" sized cabinet with solid door. Solid door option available on all sizes in black or red.

ONYX® and **NOTIFIER®** are registered trademarks of Honeywell International Inc.
©2012 by Honeywell International Inc. All rights reserved. Unauthorized use of this document is strictly prohibited.



This document is not intended to be used for installation purposes.
We try to keep our product information up-to-date and accurate.
We cannot cover all specific applications or anticipate all requirements.
All specifications are subject to change without notice.



Made in the U.S. A.

For more information, contact Notifier. Phone: (203) 484-7161, FAX: (203) 484-7118.
www.notifier.com

CHG-120

Battery Charger



Power Supplies

General

The CHG-120 is a state-of-the-art battery charging system designed for use with NOTIFIER Fire Alarm Control Panels (FACPs). It is designed to charge lead-acid batteries between 25 and 120 ampere-hours (AH).

Features

- Charges sealed lead-acid batteries.
- Automatic float-type battery charger.
- Rated for batteries of 25 to 120 ampere-hours.
- Obtains full float voltage within 48 hours.
- For use on any 24-volt FACP which can handle the specified batteries and can disable the local charger.
- AC Fail delay (central station applications) per latest NFPA requirements.
- Form-C Trouble contact.
- Dual outputs, for easy load distribution.
- **Diagnostic LEDs:**
 - Primary AC On
 - Charger Trouble.
 - Ground Fault.
 - Hi Charge.
 - Lo Charge.
 - Battery Voltage Level (3 LEDs).
 - Low Battery.
- Black or red NFS-LBB(R) battery cabinet (optional).
- Field-selectable input voltage, 120 VAC or 230 VAC.
- **Charges:**
 - 26 AH batteries within 9 hours.
 - 55/60 AH batteries within 20 hours.
 - 120 AH batteries within 38 hours.

NOTE: Values per NOTIFIER testing.

Construction and Operation

The CHG-120 consists of a PC board and mounting chassis. Charging current is provided automatically when the battery voltage falls below the charger's output voltage.

Applications

Use the CHG-120 when batteries required for standby are rated between 25 to 120 AH.

CHG-120 Specifications

Primary AC (TB1):

- 115 VAC, 60 Hz, 2 A.
- 230 VAC, 50 Hz, 1 A.

Form-C relay (TB3): 5 A at 30 VDC.

Float charge voltage: 27.6 VDC.

Maximum charging current: 4.5 A.

Fuses F1-F3: 15 A.

Battery sizes: 26 AH to 120 AH.

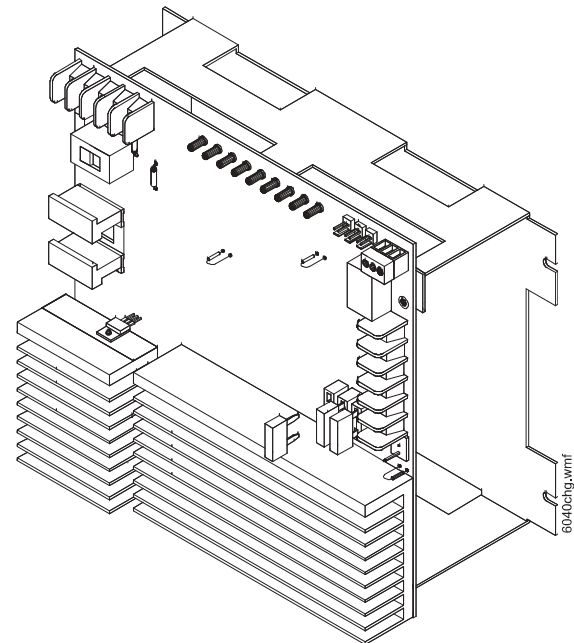

Charging time (to charge two fully discharged batteries):

- 25 AH = 9 hours.
- 55 AH/60 AH = 20 hours.
- 120 AH = 38 hours.

Installation

The CHG-120 has a variety of mounting options. It can be mounted in either a CAB-4 Series backbox or remotely in the NFS-LBB Battery Backbox. Install the CHG-120 within 20 feet (6.096 m) of the main FACP.

When mounting in a CAB-4 Series backbox:

- The CHG-120 can be mounted in the main power supply position, on the lower left of the CAB-4 Series backbox.
- Using self-tapping screws, the CHG-120 can be mounted in the lower right position (normally, where the batteries are mounted) of the CAB-4 Series backbox.

When mounting remotely in the NFS-LBB:

- The CHG-120 mounts in the left position of the backbox.

NOTE: Only one 55 AH battery or two 26 AH batteries will mount with the charger board in the NFS-LBB.

NFS-LBB Battery Box Battery Configurations: The battery backbox can mount configurations of batteries as follows:

- Without CHG-120 mounted internally:
 - Up to two 26 AH batteries.
 - Up to two 55/60 AH batteries.
 - One 100 AH battery.
- With CHG-120 mounted internally:
 - Up to two 26 AH batteries.
 - One 55/60 AH battery.
 - One 100 AH battery.

NOTE: When 100 AH batteries are required, a NFS-LBB is required to mount each 100 AH battery. The CHG-120 can mount in either the CAB-4 Series backbox or in a third NFS-LBB in this configuration.

Product Line Information

CHG-120: Battery charger circuit board and mounting chassis. Includes mounting hardware and installation instructions.

BAT-12260: 26 AH, 12-volt, sealed lead-acid battery. Order as bulk pack BAT-12260-BP, contains two. See data sheet DN-6933.

BAT-12550: 55 AH, 12-volt, sealed lead-acid battery. See data sheet DN-6933.

BAT-121000: 100 AH, 12-volt, sealed lead-acid battery. See data sheet DN-6933.

NFS-LBB: Battery Backbox — holds up to two BAT-12550 55 AH batteries or one BAT-121000 100 AH battery. Dimensions: Box: 24.0" (61.0 cm) wide x 14.0" (35.6 cm) high x 7.75" (19.7 cm) deep. Door: 24.125" (61.3 cm) wide x 14.25" (36.2 cm) high x (door adds 0.063" [approx. 0.16 cm] to depth), black.

NFS-LBBR: Same as NFS-LBB above but painted red.

CHG-120 Features

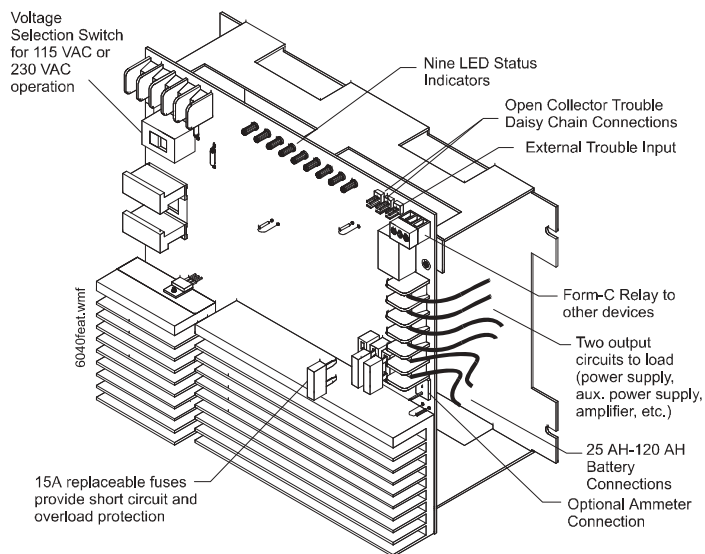

Compliance with Codes and Standards

The CHG-120 complies with the following standards:

- NFPA 72 National Fire Alarm Code.
- UL 864 Standard for Control Units for Fire Alarm Systems.
- UL 1481 Power Supplies for Fire Alarm Systems.
- CAN/ULC-S527-M87.

Agency Listings and Approvals

The listings and approvals below apply to the basic CHG-120. In some cases, certain modules may not be listed by certain approval agencies, or listing may be in process. Consult factory for latest listing status.

- **UL:** S674.
- **ULC:** S635.
- **FM:** Approved.
- **CSFM:** 7315-0028:0189.
- **MEA:** 195-97-E, 345-02-E.
- **FDNY:** #6114.

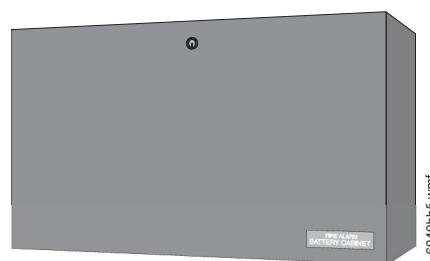

NFS-LBB Battery Backbox

NOTIFIER® is a registered trademark of Honeywell International Inc. ©2012 by Honeywell International Inc. All rights reserved. Unauthorized use of this document is strictly prohibited.



This document is not intended to be used for installation purposes. We try to keep our product information up-to-date and accurate. We cannot cover all specific applications or anticipate all requirements. All specifications are subject to change without notice.



For more information, contact Notifier. Phone: (203) 484-7161, FAX: (203) 484-7118. www.notifier.com

UDACT-2

Universal Digital Alarm Communicator Transmitter



Annunciator Control System

General

The Universal Digital Alarm Communicator Transmitter (UDACT-2) is designed for use on Notifier Fire Alarm Control Panels and on the NCA-2 Network Control Annunciator. When used in conjunction with the NCA-2 network control annunciator, the UDACT-2 can report the status of all control panels on NOTI•FIRE•NET™. The UDACT-2 transmits system status to UL listed Central Station Receivers via the public switched telephone network. The UDACT-2 can be installed in the panel cabinet or remotely in a separate enclosure.

NOTE: The UDACT-2 can also be used with legacy panels. Please refer to the UDACT-2 manual for more information.

The UDACT-2 upload/download programming and firmware updates are accomplished with VeriFire Tools. Refer to the Programming Section for further details.

The UDACT-2 is capable of transmitting the status of software zones (Alarm and Trouble), System Trouble, Panel Off-Normal, Supervisory, Bell Trouble, Low Battery, and AC Fail. The UDACT-2 is capable of transmitting all of the zone and point status associated with each panel.

When the UDACT-2 is used with the NFS-3030, NFS2-3030, and NCA-2 it is capable of reporting up to 2,040 points. Reporting may be in the form of points or zones (refer to the UDACT-2 manual for specific reporting parameters). Points transmitted may be programmed for a variety of types, including fire, water-flow, supervisory, etc.

NOTE: Descriptions regarding point capacity, listed above, are for receivers which receive in Ademco Contact ID format. See chart on page 2 for compatible receivers.

Features

- Programmable with VeriFire Tools version 6.60 or higher, allowing the UDACT-2 programming to be uploaded/downloaded and saved.
- Maximum of 14 point trouble messages transmitted per hour.
- Dual phone lines with line voltage detect.
- Compact in size: 6.75" x 4.25" (17.145 x 10.795 cm).
- USB port for upload/download programming.
- Manual Test Report function.
- Manual Transmission Clear function.
- Mounts in a separate enclosure (ABS-8RB or UBS-1B/R).
- Communicates vital system status including:
 - Independent zone fire alarm.
 - Independent zone non-fire alarm.
 - Independent zone trouble.
 - Independent zone supervisory.
 - AC (mains) Power Loss (programmable).
 - Low Battery and Earth Fault.
 - System Off-Normal.
 - 12 or 24 hour test signal.
 - Abnormal Test Signal per new UL requirements.
 - EIA-485 Communication Bus Failure.
- Annunciation of UDACT-2 Troubles including: loss of phone lines, communication failure with either Central Station, total communications failure.
- Individual LEDs for: Power, EIA-485 Loss, Manual Test, Kiss-off, Comm Fail, Primary Line Seize, Secondary Line Seize and Modem Communications.

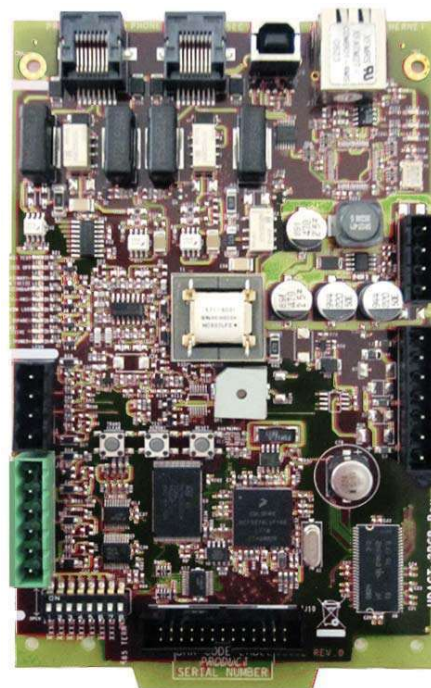

UDACT-2

- Open Collector relay driver for Total Communications Failure or UDACT-2 trouble.
- Real-time clock.
- Extensive transient protection.
- EIA-485 interface to host panel.

Programming

The UDACT-2 programming is created and downloaded using VeriFire Tools. This enables the unit to be programmed prior to installation, be easily modified, and saved either online or offline. A printed report with point or zone information can be generated from VeriFire Tools for an ONYX Series panel or network annunciator. The point report consists of the central station point address, ACS point, ACS point function, panel label, panel point, type code, custom and extended label, alarm verification, walktest participation, presignal, and PAS information. The zone report consists of a grid with the central station point address, ACS point address, source, ACS point function, custom label and panel label. This report may be sent to the Central Station for their records. VeriFire Tools also supports upgrading the UDACT-2 operating firmware.

Communication Formats

- Ademco Contact ID
- 4+2 Standard
- SIA

NOTE: Ademco Contact ID must be used for independent zone reporting.

Type Mode Feature

Ademco Contact ID format - only Use Type Mode to identify reports to Central Station as:

- Fire Alarm
- Supervisory
- Pull Station
- Heat Detector
- Waterflow
- Duct Detector
- Flame Sensor
- Smoke Zone
- Burglary
- 24 hour Non-Burglary
- High Temperature
- Low Temperature
- Low Water Pressure
- Low Water Level
- Pump Failure

Electrical Specifications

Standby current: 40 mA.

Current while communicating: 75 mA.

Maximum current while communicating and with open collector output activated: 100 mA.

Voltage: Regulated 24 volts. Range: 21.2 to 28.2 volts.

Agency Listings and Approvals

In some cases, certain modules may not be listed by certain approval agencies, or listing may be in process. Consult factory for latest listing status.

- UL/ULC Listed: S635
- FM Approved
- CSFM: 7165-0028:0243 (NFS2-640/320), 7165-0028:0224 (NFS2-3030)
- FDNY: COA#6085, COA#6098

Ordering Information

UDACT-2: Universal Digital Alarm Communicator Transmitter. Includes operating and programming instructions, and mounting hardware.

MCBL-7: DACT phone cord, 7 ft (2.13 m) long (two required).

ABS-8RB: Metal enclosure for externally mounting UDACT-2 up to 6,000 ft./1828.8 m from host FACP. 9.94" H x 4.63" W x 2.50" D (cm: 25.248 H x 11.760 W x 6.350 D).

UBS-1B: Metal enclosure with solid door, Black.

UBS-1BR: Metal enclosure with solid door, Red.

R-10E: SPDT Form-C relay. Contacts rated for 10 A @ 115 VAC. Connects to open collector relay driver.

R-20E: DPDT Two Form-C relays. Contacts rated for 10A @ 115 VAC. Connects to open collector relay driver.

FBD-1: Ferrite bead kit. Use for remote mounting only.

UL Listed Receivers

The chart below shows UL listed receivers compatible with the UDACT-2. A check in the protocol column indicates the receiver supports that protocol.

Receiver	4+2 Standard 1800/2300	Ademco Contact ID	SIA
Ademco 685 (1)	✓	✓	
Ademco MX8000 (2)	✓	✓	✓
Silent Knight 9500 (3)	✓	✓	✓
Silent Knight 9800 (4)	✓	✓	✓
FBI CP220FB (5)	✓	✓	✓
Osborne Hoffman 2000E (6)		✓	✓
Radionics 6600 (7)		✓	✓
SurGard MLR2 (8)	✓	✓	
SurGard System III (9)		✓	✓
SurGard MLR-2000 (10)		✓	

(1) With 685-8 Line Card with Rev 4.4d software

(2) With 124060V206B and 124063 Line Card Rev B

(3) With version V2.4 Receiver & 126047 Line Card Rev G

(4) With 124077V2.00 Receiver & 126047 Line Card Rev M

(5) With software V3.9

(6) With V.7301 Receiver S/W

(7) With 01.01.03 Receiver S/W & Line Card 01.01.03

(8) With software V1.86

(9) With software V1.72

(10) With DSP4016 and V1.6 Line Card

NOTIFIRENET™ is a trademark and Notifier® is a registered trademark of Honeywell International Inc.
©2012 by Honeywell International Inc. All rights reserved. Unauthorized use of this document is strictly prohibited.



This document is not intended to be used for installation purposes.
We try to keep our product information up-to-date and accurate.
We cannot cover all specific applications or anticipate all requirements.
All specifications are subject to change without notice.



Made in the U.S. A.

For more information, contact Notifier. Phone: (203) 484-7161, FAX: (203) 484-7118.
www.notifier.com

LCM-320 and LEM-320

Loop Control and Expander Modules



Intelligent Fire Alarm Control Panels

General

The LCM-320 Loop Control Module and the LEM-320 Loop Expander Module provide NOTIFIER's ONYX® Series of Fire Alarm Control Panels (FACPs) with Signaling Line Circuits (SLCs). The ONYX® Series NFS-640/NFS2-640 supports one LEM-320; the NFS-3030/NFS2-3030 supports up to five LCM-320s and five LEM-320s. The LEM-320 module is used to expand the NFS-640/NFS2-640 to a second loop, and to expand each LCM-320 used on the NFS-3030/NFS2-3030 — each NFS-3030/NFS2-3030 LCM-320 supports an expansion LEM-320.

Features

- Up to 12,500 feet (3,810 m) on a Class B (Style 4) SLC loop (twisted-unshielded).
- Built-in degraded mode increases survivability.
- Very simple installation — plug-in style.
- Permits multiple loops in small enclosure.

Specifications

Voltage: 24 VDC nominal, 27.6 VDC maximum.

Maximum loop length: The maximum wiring distance of an SLC using 12 AWG (3.1 mm²) twisted-pair wire is 12,500 feet (3810 m) per channel. For a twisted-unshielded pair, 12 AWG (3.1 mm²) to 18 AWG (0.78 mm²):

- Distance with 12 AWG: 12,500 ft (3,810 m).
- Distance with 14 AWG: 8,000 ft (2,438 m).
- Distance with 16 AWG: 4,875 ft (1,486 m).
- Distance with 18 AWG: 3,225 ft (983 m).
- 50 ohms maximum per length of Style 6 & 7 loops.
- 50 ohms maximum per branch for Style 4 loop.

Maximum current: for LCM-320: 130 mA; for LEM-320: 100 mA; for single SLC loop: 400 mA maximum.

NOTE: Maximum short circuit — loop will shut down until short-circuit condition is corrected.

Maximum resistance: 50 ohms (supervised and power-limited).

Temperature and humidity ranges: This system meets NFPA requirements for operation at 0 – 49°C/32 – 120°F and at a relative humidity 93% ± 2% RH (noncondensing) at 32°C ± 2°C (90°F ± 3°F). However, the useful life of the system's standby batteries and the electronic components may be adversely affected by extreme temperature ranges and humidity. Therefore, it is recommended that this system and its peripherals be installed in an environment with a normal room temperature of 15 – 27°C/60 – 80°F.

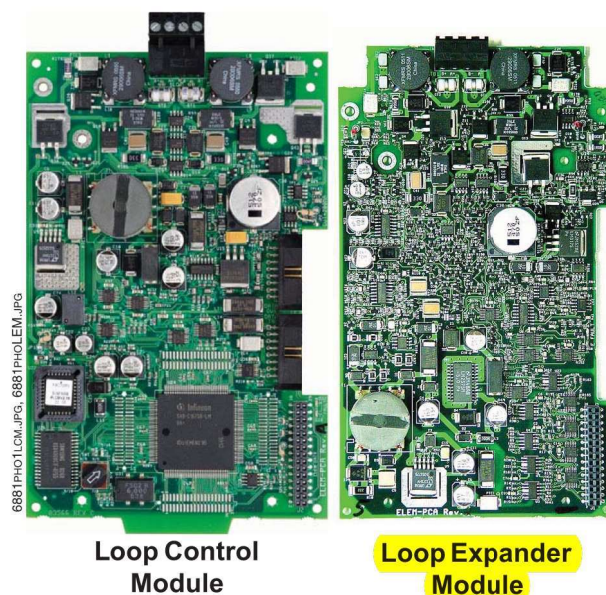

Loop Control Module

Loop Expander Module

Product Line Information

LCM-320: Loop Control Module. Adds SLCs to NFS-3030/NFS2-3030; NFS-3030/NFS2-3030 supports up to five LCM-320s and five LEM-320s.

LEM-320: Loop Expander Module. Expands each LCM used on the NFS-3030/NFS2-3030; expands NFS-640/NFS2-640 to two loops.

Agency Listings and Approvals

The listings and approvals below apply to the basic LCM-320 and LEM-320. In some cases, certain modules may not be listed by certain approval agencies, or listing may be in process. Consult factory for latest listing status.

- **UL:** S635
- **ULC:** S635/CS118
- **FM Approved**
- **CSFM:** 7165-0028:224, 7170-0028:223 (LCM/LEM-320 with NFS-3030/NFS2-3030). 7165-0028:214, 7170-0028:216 (LEM-320 with NFS-640). 7165-0028:243, 7170-0028:244 (LEM-320 with NFS2-640).
- **FDNY:** COA#6025 (LEM-320 with NFS2-640)
- **FDNY:** COA#6026 (LCM-320/LEM-320 with NFS2-3030)
- **City of Denver**
- **Hong Kong**

FLASHSCAN® and **NOTIFIER®** are registered trademarks of Honeywell International Inc.
©2009 by Honeywell International Inc. All rights reserved. Unauthorized use of this document is strictly prohibited.



This document is not intended to be used for installation purposes.
We try to keep our product information up-to-date and accurate.
We cannot cover all specific applications or anticipate all requirements.
All specifications are subject to change without notice.



Made in the U.S. A.

For more information, contact Notifier. Phone: (203) 484-7161, FAX: (203) 484-7118.
www.notifier.com

PS SERIES

6 Amp and 10 Amp, 24 Volt Power Supplies

The PS Series are independently configurable power supplies, allowing you to pair any input with any output, and feature LED diagnostics for troubleshooting.

The PS Series is a remote power supply line from Gamewell-FCI and is a direct replacement for the GFPS6/9. The HPF-PS6 is a 6 amp and the HPF-PS10 is a 10 amp, remote power supply with battery charger that may be connected to any 12 or 24 volt fire alarm control panel (FACP) or used as a standalone power supply. The PS Series provides 24 VDC power for NACs (notification appliance circuits) configured as either Class B or Class A (requires the ZNAC-PS option card) with multiple sync protocol options. The PS Series also provides auxiliary power, constant or resettable, suited for detectors, annunciators, door holders, and other fire alarm system peripherals. The PS Series cabinet can hold two 7 AH or 18 AH batteries and can charge up to 33 AH batteries in a separate cabinet.

FEATURES AND BENEFITS

- Up to five (6 amp model) or seven (10 amp model) independently-configurable, power-limited output circuits for:
 - Class B and/or Class A NACs
 - Class B and/or Class A resettable or non-resettable 24V auxiliary power
 - door holder power
- Converts from Class B to Class A wiring without losing any outputs using the ZNAC-PS converter card (sold separately)
- Optimal for powering four-wire smoke detectors, annunciators, and other system peripherals requiring regulated power
- Optional addressable control, monitor, and relay modules and power-supervision relay (EOLR-1)
- Configurable for ANSI® Temporal 3 or Temporal 4 coded output
- UL-Listed NAC synchronization using System Sensor®, Wheelock®, Gentex®, or AMSECO® appliances
- Synchronization can be triggered from FACP NAC/remote sync outputs, cascaded power supply, or a control module, single or multi, which may be housed within the power supply cabinet
- Ability to cascade up to four power supplies
- Two (6 amp model) or three (10 amp model) fully-isolated input/control circuits which can be programmed to any output
- Two Form C normally-closed trouble relays for AC Trouble and General Trouble
- 6 or 10 amp full load output, respectively, with 3 A maximum/circuit
- Individual NAC power and trouble LEDs for diagnostic efficiency
- Trouble history mode for diagnostic support
- Wide range end-of-line supervision value (normal: 2-27K ohms)
- Selectable earth fault detection (enable or disable)
- AC trouble report delay timer
- Completely configurable via onboard DIP switches, no extra software required
- Self-contained in compact, locking cabinet constructed of heavy gauge steel with a corrosion-resistant powder coat chip and scratch-resistant finish
- Cabinet designed with ten double knockouts and a removable door for ease of installation and wiring
- Includes integral battery charger capable of charging up to 33 AH batteries
- Cabinet can house two 7 AH or 18 AH batteries
- Battery charger may be disabled via DIP switch for applications requiring larger batteries and external battery charger
- Removable terminal blocks accommodate up to 12 AWG (3.1mm²) wire



HPF-PS6/10

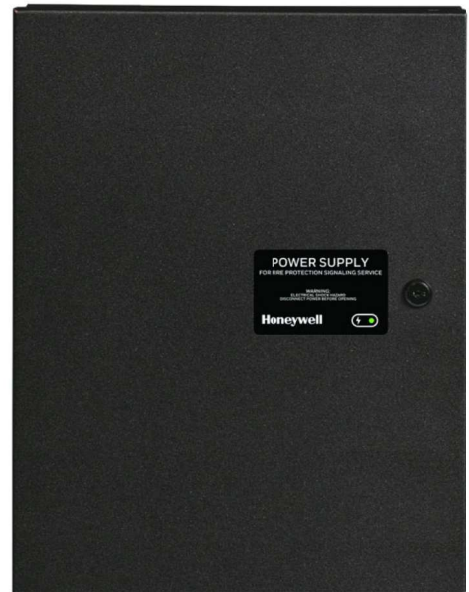

HPF-PS6/10B

- Works with any UL 864 FACP which utilizes an industry-standard reverse-polarity notification circuit
- HPF-PS6/10 include the - Honeywell Power Products lock set (PN: 1 / 059) and key (PN: 17051)

Honeywell



ORDERING INFORMATION

HPF-PS6: 6.0 A, 120 VAC remote charger power supply in a lockable, metal enclosure, red

HPF-PS6B: 6.0 A, 120 VAC remote charger power supply in a lockable, metal enclosure, black

HPF-PS10: 10.0 A, 120 VAC remote charger power supply in a lockable, metal enclosure, red

HPF-PS10B: 10.0 A, 120 VAC remote charger power supply in a lockable, metal enclosure, black

ZNAC-PS: Optional Class A converter card, sold separately

AOM-2SF: Addressable Control Module for one Class B or Class A zone of supervised, polarized Notification Appliances. Notification Appliance Circuit option requires external 24 VDC to power notification appliances.

AOM-2RF: Addressable relay module containing two isolated sets of Form-C contacts, which operate as a DPDT switch

AMM-4F: Addressable Monitor Module for one zone of normally open dry-contact initiating devices. Includes plastic cover plate and end-of-line resistor. Module may be configured for either a Class B or Class A

AMM-2IF: Dual Monitor Module. Same as AMM-4F except it provides two inputs for Class B wiring only

AMM-2RIF: Provides two monitored inputs and two Form-C relays. Functions in Class B wiring only

MMO-6SF: Six-circuit supervised control module

MMO-6RF: Six Form-C relay control module

EOLR-1: 12/24 VDC end-of-line relay for monitoring four-wire smoke detector power

BAT-1270-BP: Battery, 12 volt, 7.0 AH, 5-pack (two required)

BAT-12180-BP: Battery, 12 volt, 18AH, 2-pack

BAT-12330: Battery, 12 volt, 33AH

SEISKIT-MULTI-1: Seismic kit for the PS Series. Includes bracket and hardware for two 7AH or two 18AH batteries.

17070: Alternate Honeywell Gamewell-FCI lock set, PK-625, 3/8" cam

PS SERIES TECHNICAL SPECIFICATIONS

PRIMARY (AC) POWER

HPF-PS6(B): 120 VAC, 50/60 Hz, 5.0A maximum

HPF-PS10(B): 120VAC, 50/60 Hz, 6.2 A maximum

Wire Size: #12-14 AWG with 600 V insulation

COMMAND INPUT CIRCUIT

Trigger Input Voltage: 9 to 32 VDC

Trigger Current: 2.0 mA (16 - 32 V); Per Input: 1.0 mA (9 - 16 V)

RELAY CIRCUITS

Trouble Contact Rating: 4 A at 24 VDC

OUTPUT CIRCUITS

- 24 VDC filtered
- HPF-PS6B: TB8-TB9 – 1A Regulated, 3A special applications; TB10-TB12 – 0.3A Regulated, 3A special applications
- HPF-PS10B: TB8-TB11 – 1.5A Regulated, 3A special applications; TB12-TB14 – 0.3A Regulated, 3A special applications
- 6.0 A (HPF-PS6B) or 10.0 (HPF-PS10B) maximum total continuous current for all outputs

SECONDARY POWER (BATTERY) CHARGING CIRCUIT

- Supports lead-acid batteries only
- Float-charge voltage: 27.6 VDC
- Maximum current charge: 1.5 A
- Maximum battery capacity: 18 AH (inside cabinet)
- Maximum battery charging capacity: 33 AH (external cabinet)

PHYSICAL

Dimensions: 20.0"H x 14.5"W x 3.5"D (cm: 50.8H x 36.83W x 8.9D)

Weight: with two 7Ah batteries is 24 pounds (10.9 kg), with two 18 AH batteries is 39 pounds (17.7 kg)

STANDARDS AND CODES

The HPF-PS complies with the following standards:

NFPA 72: National Fire Alarm Code

UL 864: Standard for Control Units for Fire Alarm Systems (NAC expander mode)

UL 1481: Power Supplies for Fire Alarm Systems

AGENCY LISTINGS AND APPROVALS

These listings and approvals apply to the modules specified in this document. In some cases, certain modules or applications may not be listed by certain approval agencies, or listing may be in process. Consult factory for latest listing status.

UL Listed: S24562

CSFM: 7315-1637:0505

FDNY Approved

FM Approved

Gamewell-FCI® and System Sensor® are trademark of Honeywell International, Inc. Wheelock® is a registered trademark of Cooper Technologies Company. Gentex® is a registered trademark of Gentex Corporation. AMSECO® is a registered trademark of Potter Electric Signal Company, LLC. ANSI® is a registered trademark of the American National Standards Institute, Inc.

©2021 by Honeywell International Inc. All rights reserved. Unauthorized use of this document is strictly prohibited.

This document is not intended to be used for installation purposes. We try to keep our product information up-to-date and accurate. We cannot cover all specific applications or anticipate all requirements. All specifications are subject to change without notice.

Country of origin: USA

Honeywell Gamewell-FCI

12 Clintonville Road
Northford, CT 06472-1610
203.484.7161
www.gamewell-fci.com

9021-61096 | C | 03/21
©2021 Honeywell International Inc.



FDU-80

80 Character Liquid Crystal Display

Annunciators

General

The FDU-80 is a compact, cost-effective, 80-character, backlit LCD remote Fire Annunciator for use with the NOTIFIER Fire-Warden-100-2, NFS2-640, and NFS-320 Fire Alarm Control Panels (FACPs). The FDU-80 mimics the display of the control panel and displays complete system point status information.

Up to 32 FDU-80s may be connected onto the EIA-485 terminal port of each FACP. The FDU-80 requires no programming, which saves time during system commissioning.

Features

- 80-character Liquid Crystal Display.
- Mimics all display information from the host panel.
- Control switches for System Acknowledge, Signal Silence, Drill and Reset with enable key.
- System status LEDs for Power, Alarm, Trouble, Supervisory and Alarm Silenced.
- No programming necessary — FDU-80 connects to the terminal port on the FACP.
- Displays device type identifiers, individual point alarm, trouble or supervisory, zone and custom alpha labels.
- Time-and-date display field.
- Aesthetically pleasing design.
- May be powered from the host FACP or by remote power supply (requires 24 VDC).
- Up to 32 FDU-80 annunciators per FACP.
- Plug-in terminal blocks for ease of installation and service.
- Can be remotely located up to 6,000 feet (1828.8 m) from the FACP.
- Local piezo sounder with alarm and trouble resound.
- Semi-flush mounts to 2.188" (5.556 cm) minimum deep, three-gang electrical box (NOTIFIER PN **10103**) or three-gangable electrical switchbox.
- Surface-mounts to NOTIFIER PN **SBB-3** surface backbox.

Operation

The FDU-80 annunciator provides the FACP with point annunciation with full display text on an 80-character LCD display. The FDU-80 also provides an array of LEDs to indicate system status, and includes control switches for remote control of critical system functions.

The FDU-80 provides the FACP with up to 32 remote serially connected annunciators. All field-wiring terminations on the FDU-80 use removable, compression-type terminal blocks for ease of wiring and circuit testing.

Communication between the FACP and the annunciators is accomplished over an EIA-485 serial interface, which greatly reduces wire and installation cost over traditional systems.

Installation

The FDU-80 can be semi-flush mounted to a 2.188" (5.556 cm) minimum deep, three-gang electrical box or three-gangable electrical switchboxes. Alternately, an SBB-3 surface backbox is available for surface-mount applications.



6820fd08.jpg

Ordering Information

FDU-80: 80 character, backlit, LCD Fire Annunciator with control switches for remote control of system functions, and key-switch lock.

FDU-80C: ULC-listed version; see DN-60573 for details.

10103: Three-gang electrical box, minimum 2.188" (5.556 cm) deep, for semi-flush mount applications.

SBB-3: Three-gang surface backbox for surface-mount applications.

Agency Listings And Approvals

These listings and approvals apply to the modules specified in this document. In some cases, certain modules or applications may not be listed by certain approval agencies, or listing may be in process. Consult factory for latest listing status.

- **UL Listed:** S635
- **MEA Listed:** 245-00-E
- **FDNY:** COA#6038
- **CSFM:** 7120-0028:209
- **FM Approved**

NOTE: For ULC-listed version, see DN-60573.

NOTIFIER® is a registered trademark of Honeywell International Inc.
©2010 by Honeywell International Inc. All rights reserved. Unauthorized use
of this document is strictly prohibited.



This document is not intended to be used for installation purposes.
We try to keep our product information up-to-date and accurate.
We cannot cover all specific applications or anticipate all requirements.
All specifications are subject to change without notice.



For more information, contact Notifier. Phone: (203) 484-7161, FAX: (203) 484-7118.
www.notifier.com

DNR(A)/DNRW InnovairFlex

Intelligent Non-Relay Photoelectric Duct Smoke Detector



Intelligent Devices

General

The Notifier InnovairFlex® DNR(A) intelligent non-relay photoelectric duct smoke detector and DNRW watertight non-relay photoelectric duct smoke detector feature a pivoting housing that fits both square and rectangular footprints capable of mounting to a round or rectangular duct.

DNRW duct smoke detector, with its NEMA-4 rating, is listed as a watertight, UV resistant enclosure providing protection against falling dirt, rain, and windblown dust, splashing and hose directed water, allowing operators to use the detector in the most extreme environments.

These units sense smoke in the most challenging conditions, operating in airflow speeds of 100 to 4,000 feet per minute (0.5 to 20.32 m/s), temperatures of -4°F to 158°F (-20°C to 70°C), and a humidity range of 0 to 95 percent (non-condensing.)

An improved cover design isolates the sensor head, which allows for ease of maintenance. A cover tamper feature indicates a trouble signal for a removed or improperly installed sensor cover. The Notifier InnovairFlex housing provides a 3/4-inch conduit knockout and ample space to facilitate easy wiring and mounting of a relay module.

The Notifier InnovairFlex duct smoke detector can be customized to meet local codes and specifications without additional wiring. The new InnovairFlex product line is compatible with all previous Innovair models, including remote test accessories.

Features

- Photoelectric, integrated low-flow technology.
- Air velocity rating from 100 ft/min to 4,000 ft/min (0.5 m/s to 20.32 m/s).
- Versatile mounting options: square or rectangular configuration.
- Broad ranges for operating temperature (-4°F to 158°F, -20°C to 70°C) and humidity (0% to 95% non-condensing).
- Patented sampling tube installs from front or back of the detector with no tools required.
- Cover tamper signal.
- Increased wiring space with a newly added 3/4" conduit knockout.
- Available space within housing to accommodate mounting of a relay module.
- Easily accessible code wheels on sensor head (sold separately).
- Clear cover for convenient visual inspection.
- Remote testing capability.
- Requires com line power only.
- Accommodates the installation of an addressable relay module, sold separately, (FRM-1 or NC-100R) for applications requiring a Form-C relay.



Specifications

Size: (Rectangle) 14.38 in (37 cm) Length; 5 in (12.7 cm) Width, 2.5 in (6.6 cm) Depth.

Size: (Square) 7.75 in (19.7 cm) Length; 9 in (22.9 cm) Width; 2.5 in (6.35 cm) Depth.

Weight: 1.6 lb (0.73 kg).

Operating Temperature Range: -4°F to 158°F (-20°C to 70°C).

Storage Temperature Range: -22°F to 158°F (-30°C to 70°C).

Operating Humidity Range: 0% to 95% relative humidity (non-condensing).

Air Duct Velocity: 100 to 4,000 ft/min (0.5 to 20.32 m/s).

Accessories

Notifier provides system flexibility with a variety of accessories, including two remote test stations and different means of visible and audible system annunciation. As with our duct smoke detectors, all duct smoke detectors accessories are UL listed.

DNR(W)s with a date code of 0013 or higher do not require external 24VDC for remote test applications when used with a remote-test-capable detector.

ACCESSORY CURRENT LOADS AT 24 VDC

Device	Standby	Alarm
RA100Z	0mA	12 mA Max
RTS151/ RTS151KEY	0mA	12mA Max

Agency Listings and Approvals

Consult product manual for lists of compatible UL-Listed devices. In some cases, certain modules may not be listed by certain approval agencies, or listing may be in process. Consult factory for latest listing status.

- **UL:** S911, S3705.
- **ULC:** S635.

- CSFM: 3242-1653:0209.
- FM approved.

Product Line Information

NOTE: "A suffix indicates ULC listed model.

DNR(A): Intelligent non-relay photoelectric low flow smoke detector housing. Requires photoelectric smoke detector (sold separately).

DNRW: Watertight intelligent non-relay photoelectric low flow duct smoke detector housing. Requires photoelectric smoke detector (sold separately).

FSP-851R(A): Remote test capable addressable low-profile photoelectric smoke detector.

FSP-851(A): Addressable low-profile photoelectric smoke detector.

NP-100: Addressable low-profile photoelectric smoke detector for FireWarden series panels.

NP-100R(A): Remote test capable addressable low-profile photoelectric smoke detector for FireWarden series panels.

DCOIL: Remote test coil. Required for older DNR(W) duct detector housing.

DST1(A): Metal sampling tube duct width up to 1 ft (0.3m).

DST1.5(A): Metal sampling tube duct widths up to 1 ft to 2 ft (0.3 to 0.6 m).

DST3(A): Metal sampling tube duct widths up to 2 ft to 4 ft (0.6 to 1.2 m).

DST5(A): Metal sampling tube duct widths up to 4 ft to 8 ft (1.2 to 2.4 m).

DST10(A): Metal sampling tube duct widths up to 8 ft to 12 ft (2.4 to 3.7 m).

DH400OE-1: Weatherproof enclosure.

ETX: Metal exhaust tube duct, width 1 ft (0.3 m).

M02-04-00: Test magnet.

P48-21-00: End cap for metal sampling tubes.

RA100Z(A): Remote annunciator alarm LED.

RTS151(A): Remote test station.

RTS151KEY(A): Remote test station with key lock.

Important Note

- DNRW duct detector housings with a date code of 0013 or higher do not require a DCOIL or auxiliary 24 VDC for remote test applications when used with a remote test capable detector.
- DNRW duct detector housings with a date code of 0012 or earlier require a DCOIL and auxiliary 24 VDC power for remote test applications.

Notifier® and FlashScan® are a registered trademark of Honeywell International Inc.

©2012 by Honeywell International Inc. All rights reserved. Unauthorized use of this document is strictly prohibited.



This document is not intended to be used for installation purposes.
We try to keep our product information up-to-date and accurate.
We cannot cover all specific applications or anticipate all requirements.
All specifications are subject to change without notice.



For more information, contact Notifier. Phone: (203) 484-7161, FAX: (203) 484-7118.
www.notifier.com

FSP-951 Series

Intelligent Plug-In Photoelectric Smoke Detectors



Intelligent/Addressable Devices

General

The NOTIFIER FSP-951 Series intelligent plug-in smoke detectors are designed for both performance and aesthetics. A new modern, sleek, contemporary design and enhanced optical sensing chamber is engineered to sense smoke produced by a wide range of combustion sources in accordance with more stringent code standards. The FSP-951 Series detector sensitivity can be programmed in the control panel software. Sensitivity is continuously monitored and reported to the panel. Point ID capability allows each detector's address to be set with rotary, decimal address switches, providing exact detector location for selective maintenance when chamber contamination reaches an unacceptable level. Dual electronic thermistors add 135°F (57°C) fixed temperature thermal sensing on the FSP-951T. The FSP-951R is a remote test capable detector for use with DNR Series duct detector housings. FSP-951 series detectors are available for both FlashScan® and CLIP applications as designated.

Features

- New modern profile for improved aesthetics.
- Designed to meet UL268 7th Edition.
- Stable communication technique with noise immunity.
- Low standby current.
- Two-wire SLC connection.
- Compatible with FlashScan® and CLIP protocol systems.
- Rotary, decimal addressing (1-99 on CLIP systems, 1-159 on FlashScan systems).
- Optional remote, single-gang LED accessory.
- Dual LED design provides 360° viewing angle.
- Visible bi-color LEDs blink green every time the detector is addressed, and illuminate steady red on alarm (*FlashScan systems only*).
- Remote test feature from the panel.
- Walk test with address display (an address on 121 will blink the detector LED: 12-[pause]-1 (*FlashScan systems only*)).
- Built-in functional test switch activated by external magnet.
- Built-in tamper-resistant feature.
- Sealed against back pressure.
- Expanded color options.
- SEMS screws for wiring of the separate base.
- Optional relay, isolator, and sounder bases.

Specifications

Sensitivity:

- UL Applications: 0.5% to 4.0% per foot obscuration.
- ULC Applications: 0.5% to 3.5% per foot obscuration.

Size: 2.0" (5.3 cm) high; base determines diameter.

- B300-6: 6.1" (15.6 cm) diameter.
- B501: 4" (10.2 cm) diameter.

For a complete list of detector bases see DN-60981.

Shipping weight: 3.4oz (96.4g)

Operating Temperature range:

- FSP-951, 0°C to 50°C (32°F to 122°F).
- FSP-951T, 0°C to 38°C (32°F to 100°F).



FSP-951 in B300-6 Base

- FSP-951R installed in a DNR/DNRW, -20°C to 70°C (-4°F to 158°F).

UL/ULC Listed Velocity Range: 0-4000 ft/min. (1219.2 m/min.), suitable for installation in ducts.

Relative Humidity: 10%-93% noncondensing.

Thermal Ratings: Fixed-temperature setpoint 135°F (57°C).

DETECTOR SPACING AND APPLICATIONS

NOTIFIER recommends spacing detectors in compliance with NFPA 72. In low airflow applications with smooth ceiling, space detectors 30 feet (9.1m). For specific information regarding detector spacing, placement, and special applications refer to NFPA 72. *System Smoke Detector Application Guide*, document A05-1003, is available at systemsensor.com

ELECTRICAL SPECIFICATIONS

Voltage Range: 15-32 volts DC peak.

Standby Current (max. avg.): 200µA @ 24VDC (one communication every five seconds with LED enabled).

LED Current (max.): 4.5mA @ 24 VDC ("ON").

Installation

FSP-951 series plug-in detectors use a separate base to simplify installation, service, and maintenance.

Mount base (all base types) on an electrical backbox which is at least 1.5" (3.81 cm) deep. For a chart of compatible junction boxes, see DN-60981.

NOTE: 1) Because of inherent supervision provided by the SLC loop, end-of-line resistors are not required. Wiring "T-taps" or branches are permitted for Style 4 (Class "B") wiring. 2) When using relay or sounder bases, consult the ISO-X(A) installation sheet I56-1380 for device limitations between isolator modules and isolator bases.

Agency Listings and Approvals

These listings and approvals apply to the detectors specified in this document. In some cases, certain detectors or applications may not be listed by certain approval agencies, or listing may be in process. Consult factory for latest listing status.

- UL/ULC Listed: S911
- FM Approved
- CSFM: 7272-0028:0503

Product Line Information

NOTE:

- Detectors must be mounted to one of the Intelligent Bases listed below.
- "A" suffix indicates ULC Listed model.
- "IV" suffix indicates FlashScan® and CLIP device.

FSP-951: White, low-profile intelligent photoelectric sensor, FlashScan only.

FSP-951A: Same as FSP-951 but with ULC listing.

FSP-951-IV: Ivory, low-profile intelligent photoelectric sensor.

FSP-951A-IV: Same as FSP-951-IV but with ULC listing.

FSP-951T: White, same as FSP-951 but includes a built-in 135°F (57°C) fixed-temperature thermal device. FlashScan only.

FSP-951TA: Same as FSP-951T but with ULC listing.

FSP-951T-IV: Ivory, same as FSP-951T but includes a built-in 135°F (57°C) fixed-temperature thermal device.

FSP-951TA-IV: Same as FSP-951T-IV but with ULC listing.

FSP-951R: White, low-profile intelligent photoelectric sensor, remote test capable. For use with DNR/DNRW. FlashScan only.

FSP-951RA: Same as FSP-951R but with ULC listing. For use with DNRA.

FSP-951R-IV: Ivory, low-profile intelligent photoelectric sensor, remote test capable. For use with DNR/DNRW.

FSP-951RA-IV: Same as FSP-951R-IV but with ULC listing. For use with DNRA.

INTELLIGENT BASES

NOTE: For details on intelligent bases, see DN-60981

B300-6: White, 6" base, standard flanged low-profile mounting base.

B300-6-IV: Ivory, 6" base, standard flanged low-profile mounting base.

B300A-6: Same as B300-6, ULC listed.

B300A-6-IV: Ivory, 6" standard flanged low-profile mounting base, ULC listed.

B300-6-BP: Bulk pack of B300-6, package contains 10

B501-WHITE: White, 4" standard European flangeless mounting base. UL/ULC listed.

B501-BL: Black, 4" standard European flangeless mounting base. UL/ULC listed.

B501-IV: Ivory color, 4" standard European flangeless mounting base. UL/ULC listed.

B501-WHITE-BP: Bulk pack of B501-WHITE contains 10.

B224RB-WH: White, relay base.

B224RB-IV: Ivory, relay base.

B224RBA-WH: White, relay base, ULC listing.

B224RBA-IV: Ivory, relay base, ULC listing.

B224BI-WH: White, *isolator* detector base.

B224BI-IV: Ivory *isolator* detector base.

B224BIA-WH: White, *isolator* detector base, ULC listing.

B224BIA-IV: Ivory *isolator* detector base, ULC listing.

B200S-WH: White, Intelligent addressable sounder base capable of producing sound output in high or low volume with ANSI Temporal 3, ANSI Temporal 4, continuous tone, marching tone, and custom tone. Uses FlashScan protocol.

B200S-IV: Ivory, Intelligent addressable sounder base capable of producing sound output in high or low volume with ANSI Temporal 3, ANSI Temporal 4, continuous tone, marching tone, and custom tone. Uses FlashScan protocol.

B200SA-WH: Same as B200S-WH, ULC listing.

B200SA-IV: Same as B200S-IV, ULC listing.

B200SCOA-WH: White, Intelligent, programmable sounder base in English/French (required in Canada for ULC applications with SO Series detector applications).

B200SCOA-IV: Ivory Intelligent, programmable sounder base in English/French (required in Canada for ULC applications with SO Series detector applications, ULC listing).

B200S-LF-WH: White, Low Frequency Intelligent, programmable sounder base. Produces a fundamental frequency of 520 Hz +/- 10% with a square wave or its equivalent; designed to meet the NFPA 72 sleeping space requirement.

B200S-LF-IV: Ivory, Low Frequency Intelligent, programmable sounder base. Produces a fundamental frequency of 520 Hz +/- 10% with a square wave or its equivalent; designed to meet the NFPA 72 sleeping space requirement.

B200SR-WH: White, Intelligent sounder base capable of producing sound output with ANSI Temporal 3 or continuous tone. Intended for retrofit applications.

B200SR-IV: Ivory, Intelligent sounder base capable of producing sound output with ANSI Temporal 3 or continuous tone. Intended for retrofit applications.

B200SRA-WH: Same as B200SR-WH with, ULC listing.

B200SRA-IV: Same as B200SR-IV in Ivory color, ULC listing.

B200SR-LF-WH: White, Low Frequency Intelligent, programmable sounder base. Produces a fundamental frequency of 520 Hz +/- 10% with a square wave or its equivalent; designed to meet the NFPA 72 sleeping space requirement. Intended for retrofit applications.

B200SR-LF-IV: Ivory, Low Frequency Intelligent, programmable sounder base. Produces a fundamental frequency of 520 Hz +/- 10% with a square wave or its equivalent; designed to meet the NFPA 72 sleeping space requirement. Intended for retrofit applications.

MOUNTING KITS AND ACCESSORIES

TR300: White, replacement flange for B210LP(A) base.

TR300-IV: Ivory, replacement flange for B210LP(A) base.

RA100Z(A): Remote LED annunciator. 3 – 32 VDC. Mounts to a U.S. single-gang electrical box. For use with B501(A) and B300(A)-6.

M02-04-00: Test magnet.

M02-09-00: Test magnet with telescoping handle.

©2018 by Honeywell International Inc. All rights reserved. Unauthorized use of this document is strictly prohibited.



This document is not intended to be used for installation purposes.
We try to keep our product information up-to-date and accurate.
We cannot cover all specific applications or anticipate all requirements.
All specifications are subject to change without notice.

For more information, contact Notifier. Phone: (800) 627-3473, FAX: (203) 484-7118.
www.notifier.com

FST-951 Series Intelligent Addressable Heat Detectors

The NOTIFIER® FST-951 Series intelligent thermal detectors are designed for both performance and aesthetics, and are direct replacements for the FST-851 Series. A new modern, sleek, contemporary design and advanced thermal technologies make the FST-951 Series ideal for both system operation and building design. The point ID address, set using rotary decimal switches, provide specific detector locations.

The series includes a 135°F/57°C fixed-temperature, rate-of-rise, and a 190°F/88°C fixed high-temperature detectors. These thermal detectors provide effective, intelligent property protection in a variety of applications. Detectors are available for both FlashScan® and CLIP applications as designated.

Features

SLC LOOP:

- Two-wire SLC loop connection
- Unit uses base for wiring

ADDRESSING:

- Addressable by device
- Rotary, decimal addressing
(Refer to the *NOTIFIER panel manuals* for device capacity.)

ARCHITECTURE:

- Designed to meet UL 268 7th Edition
- Sleek, low-profile, stylish design
- State-of-the-art thermistor technology for fast response
- Integral communications and built-in device-type identification
- Built-in tamper resistant feature
- Built-in functional test switch activated by external magnet

OPERATION:

- Fixed temperature model (FST-951) factory preset to 135°F (57°C)
- Rate-of-rise model (FST-951R), 15°F (8.3°C) per minute
- High-temperature model (FST-951H) factory preset to 190°F (88°C)
- 360°-field viewing angle of the two visual alarm indicators, LEDs blink red in Normal condition and turn on steady red in Alarm
- LEDs blink every time the unit is polled

MECHANICALS:

- Sealed against back pressure
- SEMS screws for wiring of the separate base
- Designed for direct-surface or electrical-box mounting
- Plugs into separate base for ease of installation and maintenance
- Separate base allows interchange of photoelectric, ionization and thermal sensors

OTHER SYSTEM FEATURES:

- Remote test feature from the panel
- Walk test with address display
- Low standby current

OPTIONS:

- Remote LED output connection to optional RA100Z remote LED annunciator



Installation

FST-951 Series plug-in intelligent thermal detectors use a detachable base to simplify installation, service and maintenance. Installation instructions are shipped with each detector.

Mount detector base (all base types) on an electrical backbox which is at least 1.5" (3.81 cm) deep. For a chart of compatible junction boxes, see *DN-60054*.

NOTE: Because of the inherent supervision provided by the SLC loop, end-of-line resistors are not required. Wiring "T-taps" or branches are permitted for Style 4 (Class "B") wiring only. When using relay or sounder bases, consult the ISO-X(A) installation sheet I56-1380 for device limitations between isolator modules and isolator bases.

Applications

Use thermal detectors for protection of property. For further information, refer to I56-6522, Applications Manual for System Smoke Detectors, which provides detailed information on detector spacing, placement, zoning, wiring, and special applications.

Construction

These detectors are constructed of fire-resistant plastic. The FST-951 Series plug-in intelligent thermal detectors are designed to commercial standards and offer an attractive appearance.

Operation

Each FST-951 Series detector uses one of the panel's addresses (total limit is panel dependent) on the NOTIFIER Signaling Line Circuit (SLC). It responds to regular polls from the control panel and reports its type and the status. If it receives a test command from the panel (or a local magnet test), it stimulates its electronics and reports an alarm. It blinks its LEDs when polled and turns the LEDs on when commanded by the panel. The FST-951 Series offers features and performance that represent the latest in thermal detector technology.

Product Line Information

NOTE: ¹-IV" suffix indicates CLIP and FlashScan device.

FST-951: White, low-profile intelligent 135°F fixed thermal sensor, FlashScan only

FST-951A: Same as FST-951 but with ULC listing

FST-951-IV: Ivory, low-profile intelligent 135°F fixed thermal sensor, FlashScan and CLIP

FST-951A-IV: Same as FST-951-IV but with ULC listing

FST-951R: White, low-profile intelligent rate-of-rise thermal sensor, FlashScan only

FST-951RA: Same as FST-951 but with ULC listing

FST-951R-IV: Ivory, low-profile intelligent rate-of-rise fixed thermal sensor, FlashScan and CLIP

FST-951RA-IV: Same as FST-951R-IV but with ULC listing

FST-951H: White, low-profile intelligent 190°F fixed thermal sensor, FlashScan only

FST-951HA: Same as FST-951H but with ULC listing

FST-951H-IV: Ivory, low-profile intelligent 190°F thermal sensor, FlashScan and CLIP

FST-951HA-IV: Same as FST-951 but with ULC listing

INTELLIGENT BASES

NOTE: For details on intelligent bases, see DN-60981.

B300-6: White, 6" base, standard flanged low-profile mounting base (CSFM: 7300-1653:0109)

B300-6-IV: Ivory, 6" base, standard flanged low-profile mounting base (CSFM: 7300-1653:0109)

B300A-6: Same as B300-6, ULC listed

B300A-6-IV: Ivory, 6" standard flanged low-profile mounting base, ULC listed

B300-6-BP: Bulk pack of B300-6, package contains 10

B501-WHITE: White, 4" standard European flangeless mounting base. UL/ULC listed (CSFM: 7300-1653:0109)

B501-BL: Black, 4" standard European flangeless mounting base. UL/ULC listed (CSFM: 7300-1653:0109)

B501-IV: Ivory color, 4" standard European flangeless mounting base. UL/ULC listed (CSFM: 7300-1653:0109)

B501-WHITE-BP: Bulk pack of B501-WHITE contains 10

B224RB-WH: White, relay base (CSFM: 7300-1653:0216)

B224RB-IV: Ivory, relay base (CSFM: 7300-1653:0216)

B224RBA-WH: White, relay base, ULC listing

B224RBA-IV: Ivory, relay base, ULC listing

B224BI-WH: White, isolator detector base (CSFM: 7300-1653:0216)

B224BI-IV: Ivory isolator detector base (CSFM: 7300-1653:0216)

B224BIA-WH: White, isolator detector base, ULC listing

B224BIA-IV: Ivory isolator detector base, ULC listing

B200S-WH: White, Intelligent addressable sounder base capable of producing sound output in high or low volume with ANSI Temporal 3, ANSI Temporal 4, continuous tone, marching tone, and custom tone. Uses FlashScan protocol. (CSFM: 7300-1653:0213)

B200S-IV: Ivory, Intelligent addressable sounder base capable of producing sound output in high or low volume with ANSI Temporal 3, ANSI Temporal 4, continuous tone, marching tone, and custom tone. Uses FlashScan protocol. (CSFM: 7300-1653:0213)

B200SA-WH: Same as B200S-WH, ULC listing

B200SA-IV: Same as B200S-IV, ULC listing

B200SCOA-WH: White, Intelligent, programmable sounder base in English/French (required in Canada for ULC applications with CO Series detector applications)

B200SCOA-IV: Ivory Intelligent, programmable sounder base in English/French (required in Canada for ULC applications with CO Series detector applications, ULC listing)

B200S-LF-WH: White, Low Frequency Intelligent, programmable sounder base. Produces a fundamental frequency of 520 Hz +/- 10% with a square wave or its equivalent; designed to meet the NFPA 72 sleeping space requirement. (CSFM: 7300-1653:0238)

B200S-LF-IV: Ivory, Low Frequency Intelligent, programmable sounder base. Produces a fundamental frequency of 520 Hz +/- 10% with a square wave or its equivalent; designed to meet the NFPA 72 sleeping space requirement. (CSFM: 7300-1653:0238)

B200SR-WH: White, Intelligent sounder base capable of producing sound output with ANSI Temporal 3 or continuous tone. Intended for retrofit applications. (CSFM: 7300-1653:0213)

B200SR-IV: Ivory, Intelligent sounder base capable of producing sound output with ANSI Temporal 3 or continuous tone. Intended for retrofit applications. (CSFM: 7300-1653:0213)

B200SRA-WH: Same as B200SR-WH with, ULC listing

B200SRA-IV: Same as B200SR-IV in Ivory color, ULC listing

B200SR-LF-WH: White, Low Frequency Intelligent, programmable sounder base. Produces a fundamental frequency of 520 Hz +/- 10% with a square wave or its equivalent; designed to meet the NFPA 72 sleeping space requirement. Intended for retrofit applications. (CSFM: 7300-1653:0238)

B200SR-LF-IV: Ivory, Low Frequency Intelligent, programmable sounder base. Produces a fundamental frequency of 520 Hz +/- 10% with a square wave or its equivalent; designed to meet the NFPA 72 sleeping space requirement. Intended for retrofit applications. (CSFM: 7300-1653:0238)

MOUNTING KITS AND ACCESSORIES

TR300: White, replacement flange for B210LP(A) base

TR300-IV: Ivory, replacement flange for B210LP(A) base

RA100Z(A): Remote LED annunciator. 3-32 VDC. Mounts to a U.S. single-gang electrical box. For use with B501(A) and B300-6(A).

M02-04-00: Test magnet

M02-09-00: Test magnet with telescoping handle

CK300: Color Kit (includes cover and trim ring), white, 10-pack

CK300-IV: Color Kit (includes cover and trim ring), ivory, 10-pack

CK300-BL: Color Kit (includes cover and trim ring), black, 10-pack

SPECIFICATIONS

Sensitivity: UL Applications: 0.5% to 4.0% per foot obscuration.
ULC is 0.5% to 3.5%

Size: 2.0" (5.3 cm) high; base determines diameter

- **B300-6:** 6.1" (15.6 cm) diameter
- **B501:** 4" (10.2 cm) diameter

For a complete list of detector bases see DN-60981

Shipping weight: 3.4 oz. (95 g)

Operating temperature range:

- FST-951, FST-951R Series: –4°F to 100°F (–20°C to 38°C)
- FST-951H Series: –4°F to 150°F (–20°C to 66°C)

Detector spacing: UL approved for 50 ft. (15.24 m) center-to-center, FM approved for 25 x 25 ft. (7.62 x 7.62 m) spacing

Relative humidity: 10% – 93% non-condensing

Thermal ratings: fixed-temperature set point 135°F (57°C), rate-of-rise detection 15°F (8.3°C) per minute, high temperature heat 190°F (88°C)

Mounting: B300-6(A) flanged base, included

See “**Product Line Information: Intelligent Bases,**” if using a different base.

ELECTRICAL SPECIFICATIONS

Voltage range: 15 - 32 volts DC peak

Standby current (max. avg.): 200µA @ 24 VDC (one communication every 5 seconds with LED enabled)

Max current: 4.5 mA @ 24 VDC (“ON”)

Listings and Approvals

Listings and approvals below apply to the FST-951 Series detectors. In some cases, certain modules may not be listed by certain approval agencies, or listing may be in process. Consult factory for latest listing status.

- UL/ULC Listing: S747
- FM Approved
- CSFM: 7270-0028:0502



This document is not intended to be used for installation purposes.
We try to keep our product information up-to-date and accurate.
We cannot cover all specific applications or anticipate all requirements.
All specifications are subject to change without notice.

FlashScan® and NOTIFIER® are registered trademarks of Honeywell International, Inc.

©2019 by Honeywell International Inc. All rights reserved. Unauthorized use of this document is strictly prohibited.

Country of Origin: Mexico

NOTIFIER

12 Clintonville Road
Northford, CT 06472
203.484.7161
www.notifier.com



Intelligent Bases Standard, Relay, Isolator, Sounder, and Low-Frequency Sounder Bases

General

Intelligent FlashScan® and CLIP detector mounting bases are available to install NOTIFIER detectors in any application. Bases are available for the new, modern looking aesthetically pleasing 900 series addressable detectors, as well as previous series detectors. Both flanged and flangeless bases are available.

To meet code and specific application requirements **Relay, Isolator and Sounder Bases** versions are available. Relay bases provide one form-C contact for auxiliary functions such as door closure and elevator recall. Isolator bases allow loops to continue to operate under fault conditions and automatically restore when the fault is removed. Sounder bases are available in temporal and non-temporal pattern versions depending on whether the signal is to be used for evacuation purposes. Low frequency sounder bases are UL listed for low frequency operation and comply with NFPA 72 requirements for sleeping spaces.

Specifications

NOTE: Specifications applies to all model variants "A", "-BL", "-LF", "-IV". See Product Line Information for detailed model description.

Diameter

- B501: 4" (10.16 cm) diameter.
- B300-6: 6.1" (15.49 cm) diameter.
- B224RI, B224RB, B210LP: 6.2" (15.748 cm) diameter.
- B200S, B200SR, B200SCOA: 6.875" (17.46 cm) diameter.

Wire gauge:

- B224BI, B224RB: 14 to 24 AWG.
- B300-6, B210LP, B501, B200S, B200SR, B200SCOA: 12 to 24 AWG

Temperature range:

- B224BI, B224RB, B200S, B200SR, B200SCOA: 32°F to 120°F (0°C to 49°C).
- B300-6, B210LP, B501: -4°F to 150°F (-20°C to 66°C).

Humidity range: 10% to 93% RH, non-condensing.

System temperature and humidity ranges: This system meets NFPA requirements for operation at 0°C to 49°C (32°F to 120°F); and at a relative humidity (noncondensing) of 85% at 30°C (86°F) per NFPA, and 93% ± 2% at 32°C ± 2°C (89.6°F ± 1.1°F) per ULC. However, the useful life of the system's standby batteries and the electronic components may be adversely affected by extreme temperature ranges and humidity. Therefore, it is recommended that this system and all peripherals be installed in an environment with a nominal room temperature of 15°C to 27°C (60°F to 80°F).

Electrical Ratings

FOR B200 SERIES BASES:

External supply voltage: 16 to 33 VDC (VFWR)

Standby current:

500 µA maximum.

Alarm current:

- B200S(A)(-IV)
 - 35 mA maximum at high-volume setting.
 - 15 mA maximum at low-volume setting.
- B200S-LF(-IV), High-volume setting:



Flangeless Mounting Base
B501(A)



Flanged Mounting Base
B210LP(A)



Sounder Base
B200S(A), B200SR(A),
B200SCOA



Relay Base
B224RB(A)



Low-Frequency
Sounder
Base B200S-LF,
B200SR-LF



Standard Flanged
Low-Profile Base
B300-6

- 70 mA maximum @ 33.0 VDC.
- 90 mA maximum @ 24.0 VDC.
- 140 mA maximum @ 16.0 VDC.
- B200S-LF(-IV), Low-volume setting:
 - 15 mA maximum @ 33.0 VDC.
 - 20 mA maximum @ 24.0 VDC.
 - 25 mA maximum @ 16.0 VDC.
- B200SR(A)(-IV)
 - 35 mA maximum.
- B200SR-LF(-IV)
 - 65 mA maximum @ 33.0 VDC.
 - 90 mA maximum @ 24.0 VDC.
 - 125 mA maximum @ 16.0 VDC.
- B200SCOA(-IV)
 - 40mA Max. (DC)
 - 70mA Max. (FWR)

SLC operating voltage: 15 to 32 VDC.

SLC standby current: See applicable sensor specification.

Sound output:

- B200S(A)(-LF)(-IV), high-volume*: Greater than 85 dBA minimum.
- B200S(A)(-LF)(-IV), low-volume*: Greater than 75 dBA minimum.
- B200SR(A)(-LF)(-IV)*: Greater than 85 dBA minimum.
- B200SCOA(-IV), high-volume**: Greater than 87 dBA minimum.
- B200SCOA(-IV), low-volume**: Greater than 85 dBA minimum

*Measured in a UL reverberant room at 10 feet, 24 Volts (continuous tone)

**Measured in a ULC anechoic room at 10 feet, 24 Volts continuous tone)

FOR B224BI, B224RB (A) (-IV):

Operating voltage: 15 to 32 VDC (powered by SLC).

Standby ratings: <500 µA maximum @ 24 VDC.

Set time (B224RB(A)-(-IV) only): short delay 55 to 90 msec; long delay 6 to 9 seconds.

Reset time (B224RB(A)-(-IV) only): 20 msec maximum.

Relay characteristics (B224RB(A)-(-IV) only): two-coil latching relay; one Form-C contact; ratings (UL/CSA): 0.9 A @ 125 VAC, 0.9 A @ 110 VDC, and 3.0 A @ 30 VDC.

Product Line Information

INTELLIGENT BASES

NOTE: "A" suffix indicates ULC Listed model.

NOTE: "-IV" suffix indicates Ivory color model.

NOTE: "-BL" suffix indicates Black color model.

B210LP: Flanged mounted base.

B210LPA: Same as B210LP ULC listed.

B210LPBP: Bulk pack of B210LP contains 10.

B300-6: White, 6" base, standard flanged low-profile mounting base. (CSFM: 7300-1653:0109)

B300A-6: Same as B300-6, ULC listed.

B300-6-BP: Bulk pack of B300-6, package contains 10

B300-6-IV: Ivory, 6" base, standard flanged low-profile mounting base. (CSFM: 7300-1653:0109)

B300A-6-IV: Ivory, 6" standard flanged low-profile mounting base, ULC listed.

B501-WHITE: White, 4" standard European flangeless mounting base. UL/ULC listed. (CSFM: 7300-1653:0109)

B501-WHITE-BP: Bulk pack of B501-WHITE contains 10.

B501-BL: Black, 4" standard European flangeless mounting base. UL/ULC listed. (CSFM: 7300-1653:0109)

B501-IV: Ivory color, 4" standard European flangeless mounting base. UL/ULC listed. (CSFM: 7300-1653:0109)

B224RB-WH: White, relay base. (CSFM: 7300-1653:0216)

B224RB-IV: Ivory, relay base. (CSFM: 7300-1653:0216)

B224RBA-WH: White, relay base, ULC listing.

B224RBA-IV: Ivory, relay base, ULC listing.

B224BI-WH: White, *isolator* detector base. (CSFM: 7300-1653:0216)

B224BI-IV: Ivory *isolator* detector base. (CSFM: 7300-1653:0216)

B224BIA-WH: White, *isolator* detector base, ULC listing.

B224BIA-IV: Ivory *isolator* detector base, ULC listing.

B200S-WH: White, Intelligent addressable sounder base capable of producing sound output in high or low volume with ANSI Temporal 3, ANSI Temporal 4, continuous tone, marching tone, and custom tone. Uses FlashScan protocol. (CSFM: 7300-1653:0213)

B200S-IV: Ivory, Intelligent addressable sounder base capable of producing sound output in high or low volume with ANSI Temporal 3, ANSI Temporal 4, continuous tone, marching tone, and custom tone. Uses FlashScan protocol. (CSFM: 7300-1653:0213)

B200SA-WH: Same as B200S-WH, ULC listing.

B200SA-IV: Same as B200S-IV, ULC listing.

B200SCOA-WH: White, Intelligent, programmable sounder base in English/French (required in Canada for ULC applications with SO Series detector applications).

B200SCOA-IV: Ivory Intelligent, programmable sounder base in English/French (required in Canada for ULC applications with SO Series detector applications, ULC listing).

B200S-LF-WH: White, Low Frequency Intelligent, programmable sounder base. Produces a fundamental frequency of 520 Hz +/- 10% with a square wave or its equivalent; designed to meet the NFPA 72 sleeping space requirement. (CSFM: 7300-1653:0238)

B200S-LF-IV: Ivory, Low Frequency Intelligent, programmable sounder base. Produces a fundamental frequency of 520 Hz +/- 10% with a square wave or its equivalent; designed to meet the NFPA 72 sleeping space requirement. (CSFM: 7300-1653:0238)

B200SR-WH: White, Intelligent sounder base capable of producing sound output with ANSI Temporal 3 or continuous tone. Intended for retrofit applications. (CSFM: 7300-1653:0213)

B200SR-IV: Ivory, Intelligent sounder base capable of producing sound output with ANSI Temporal 3 or continuous tone. Intended for retrofit applications. (CSFM: 7300-1653:0213)

B200SRA-WH: Same as B200SR-WH with, ULC listing.

B200SRA-IV: Same as B200SR-IV in Ivory color, ULC listing.

B200SR-LF-WH: White, Low Frequency Intelligent, programmable sounder base. Produces a fundamental frequency of 520 Hz +/- 10% with a square wave or its equivalent; designed to meet the NFPA 72 sleeping space requirement. Intended for retrofit applications. (CSFM: 7300-1653:0238)

B200SR-LF-IV: Ivory, Low Frequency Intelligent, programmable sounder base. Produces a fundamental frequency of 520 Hz +/- 10% with a square wave or its equivalent; designed to meet the NFPA 72 sleeping space requirement. Intended for retrofit applications. (CSFM: 7300-1653:0238)

MOUNTING KITS AND ACCESSORIES

TR300: White, replacement flange for B210LP(A) base.

TR300-IV: Ivory, replacement flange for B210LP(A) base.

RA100Z(A): Remote LED annunciator. 3 – 32 VDC. Mounts to a U.S. single-gang electrical box. For use with B501(A) and B300(A)-6.

M02-04-00: Test magnet.

M02-09-00: Test magnet with telescoping handle.

XR2B: Detector removal tool. Allows installation and/or removal of detector heads from bases in high ceiling applications.

XP-4: Extension pole for XR2B. Comes in three 5-foot (1.524m) sections.

T55-127-010: Detector removal tool without pole.

CK300: White, detector color kit. Pack of 10.

CK300-IR: White, detector color kit for use with FPTI and FCO Series detectors. Pack of 10.

CK300-IV: Ivory, detector color kit. Pack of 10.

CK300-IR-IV: Ivory, detector color kit for use with FPTI and FCO Series detectors. Pack of 10.

CK300-BL: Black, detector color kit. Pack of 10.

CK300-IR-BL: Black, detector color kit for use with FPTI and FCO Series detectors. Pack of 10.

Agency Listings and Approvals

The listings and approvals below apply to intelligent bases as noted. In some cases, certain modules or applications may not be listed by certain approval agencies, or listing may be in process. Consult factory for latest listing status.

- **UL Listed:** S911, S1115
- **ULC Listed:** S911, S1115.
- **FM Approved.**
- **MEA:** 22-95-E, 205-94-E Vol. 2; 257-06-E
- **CSFM:** 7270-0028-0502, 7272-0028:0503, 7300-1653:0126, 7135-1653:0213, 7300-1653:0109

Junction Box Selection Guide

Base Models	Single Gang	3.5" Oct.	4.0" Oct.	4.0" Sq.	4.0" Sq. with 3.0" mud ring	50 mm	60 mm	70 mm	75 mm
B200S, B200SR, B200SCOA	Yes	Yes	Yes	Yes	Yes	No	No	No	No
B501	No	Yes	No	No	Yes	Yes	Yes	Yes	No
B210LP	Yes	Yes	Yes	Yes	Yes	No	No	No	No
B224RB	No	Yes	Yes	Yes	No	No	Yes	Yes	Yes
B224BI	No	Yes	Yes	Yes	No	No	No	Yes	Yes

NOTE: Box depth contingent on base and wire size.
Refer to National Electric Code or applicable local codes for appropriate recommendations.

NOTE: Applies to all model variants "A", "-BL", "-LF", "-IV". See Product Line Information for detailed model description.



This document is not intended to be used for installation purposes.
We try to keep our product information up-to-date and accurate.
We cannot cover all specific applications or anticipate all requirements.
All specifications are subject to change without notice.

FlashScan®, **NOTIFIER®** and **System Sensor®** are registered trademarks of Honeywell International Inc.
©2018 by Honeywell International Inc. All rights reserved.
Unauthorized use of this document is strictly prohibited.

Country of Origin: USA

NOTIFIER
12 Clintonville Road
Northford, CT 06472
203.484.7161
www.notifier.com



FCM-1(A) & FRM-1(A) Series

Control and Relay Modules



Intelligent / Addressable Devices

General

FCM-1(A) Control Module: The FCM-1(A) Addressable Control Module provides Notifier intelligent fire alarm control panels a circuit for Notification Appliances (horns, strobes, speakers, etc.). Addressability allows the FCM-1(A) to be activated, either manually or through panel programming, on a select (zone or area of coverage) basis.

FRM-1(A) Relay Module: The FRM-1(A) Addressable Relay Module provides the system with a dry-contact output for activating a variety of auxiliary devices, such as fans, dampers, control equipment, etc. Addressability allows the dry contact to be activated, either manually or through panel programming, on a select basis.

FlashScan® (U.S. Patent 5,539,389) is a communication protocol developed by NOTIFIER Engineering that greatly enhances the speed of communication between analog intelligent devices. Intelligent devices communicate in a grouped fashion. If one of the devices within the group has new information, the panel CPU stops the group poll and concentrates on single points. The net effect is response speed greater than five times that of other designs.



FCM-1(A)

Features

- Built-in type identification automatically identifies these devices to the control panel.
- Internal circuitry and relay powered directly by two-wire SLC loop. The FCM-1(A) module requires power (for horns, strobes, etc.), or audio (for speakers).
- Integral LED “blinks” green each time a communication is received from the control panel and turns on in steady red when activated.
- LED blink may be deselected globally (affects all devices).
- High noise immunity (EMF/RFI).
- The FCM-1(A) may be used to switch 24-volt NAC power, audio (up to 70.7 Vrms).
- Wide viewing angle of LED.
- SEMS screws with clamping plates for wiring ease.
- Direct-dial entry of address 01– 159 for FlashScan loops, 01 – 99 for CLIP mode loops.
- Speaker, and audible/visual applications may be wired for Class B or A (Style Y or Z).

Applications

The FCM-1(A) is used to switch 24 VDC audible/visual power, high-level audio (speakers). The FRM-1(A) may be programmed to operate dry contacts for applications such as door holders or Air Handling Unit shutdown, and to reset four-wire smoke detector power.

NOTE: Refer to the SLC Manual (PN 51253) for details regarding releasing applications with the FCM-1(A). Refer to the FCM-1-REL datasheet (DN-60390) for new FlashScan® releasing applications.

Construction

- The face plate is made of off-white heat-resistant plastic.
- Controls include two rotary switches for direct-dial entry of address (01-159).

- The FCM-1(A) is configured for a single Class B (Style Y) or Class A (Style Z) Notification Appliance Circuit.
- The FRM-1(A) provides two Form-C dry contacts that switch together.

Operation

Each FCM-1(A) or FRM-1(A) uses one of 159 possible module addresses on a SLC loop (99 on CLIP loops). It responds to regular polls from the control panel and reports its type and status, including the open/normal/short status of its Notification Appliance Circuit (NAC). The LED blinks with each poll received. On command, it activates its internal relay. The FCM-1(A) supervises Class B (Style Y) or Class A (Style Z) notification or control circuits.

Upon code command from the panel, the FCM-1(A) will disconnect the supervision and connect the external power supply in the proper polarity across the load device. The disconnection of the supervision provides a positive indication to the panel that the control relay actually turned ON. The external power supply is always relay isolated from the communication loop so that a trouble condition on the external power supply will never interfere with the rest of the system.

Rotary switches set a unique address for each module. The address may be set before or after mounting. The built-in TYPE CODE (not settable) will identify the module to the control panel, so as to differentiate between a module and a sensor address.

Specifications for FCM-1(A)

Normal operating voltage: 15 to 32 VDC.

Maximum current draw: 6.5 mA (LED on).

Average operating current: 350 μ A direct poll, 375 μ A group poll with LED flashing, 485 μ A Max. (LED flashing, NAC shorted.)

Maximum NAC Line Loss: 4 VDC.

External supply voltage (between Terminals T10 and T11): Maximum (NAC): Regulated 24 VDC; Maximum (Speakers): 70.7 V RMS, 50W.

Drain on external supply: 1.7 mA maximum using 24 VDC supply; 2.2 mA Maximum using 80 VRMS supply.

Max NAC Current Ratings: For class B wiring system, the current rating is 3A; For class A wiring system, the current rating is 2A.

Temperature range: 32°F to 120°F (0°C to 49°C).

Humidity range: 10% to 93% non-condensing.

Dimensions: 4.5" (114.3 mm) high x 4" (101.6 mm) wide x 1.25" (31.75 mm) deep. Mounts to a 4" (101.6 mm) square x 2.125" (53.975 mm) deep box.

Accessories: SMB500 Electrical Box; CB500 Barrier

Specifications for FRM-1(A)

Normal operating voltage: 15 to 32 VDC.

Maximum current draw: 6.5 mA (LED on).

Average operating current: 230 µA direct poll; 255 µA group poll.

EOL resistance: not used.

Temperature range: 32°F to 120°F (0°C to 49°C).

Humidity range: 10% to 93% non-condensing.

Dimensions: 4.5" (114.3 mm) high x 4" (101.6 mm) wide x 1.25" (31.75 mm) deep. Mounts to a 4" (101.6 mm) square x 2.125" (53.975 mm) deep box.

Accessories: SMB500 Electrical Box; CB500 Barrier

Agency Listings and Approvals

In some cases, certain modules may not be listed by certain approval agencies, or listing may be in process. Consult factory for latest listing status.

- **UL:** S635
- **ULC:** S3705 (A version only)
- **FM Approved**
- **CSFM:** 7300-0028:0219
- **MEA:** 14-00-E
- **FDNY:** COA #6067, #6065

Contact Ratings for FRM-1(A)

Current Rating	Maximum Voltage	Load Description	Application
3 A	30 VDC	Resistive	Non-Coded
2 A	30 VDC	Resistive	Coded
.9 A	110 VDC	Resistive	Non-Coded
.9 A	125 VDC	Resistive	Non-Coded
.5 A	30 VDC	Inductive (L/R=5ms)	Coded
1 A	30 VDC	Inductive (L/R=2ms)	Coded
.3 A	125 VAC	Inductive (PF=0.35)	Non-Coded
1.5 A	25 VAC	Inductive (PF=0.35)	Non-Coded
.7 A	70.7 VAC	Inductive (PF=0.35)	Non-Coded
2 A	25 VAC	Inductive (PF=0.35)	Non-Coded

NOTE: Maximum (Speakers): 70.7 V RMS, 50 W

Product Line Information

NOTE: "A" suffix indicates ULC Listed model.

FCM-1(A): Intelligent Addressable Control Module.

FRM-1(A): Intelligent Addressable Relay Module.

A2143-20: Capacitor, required for Class A (Style Z) operation of speakers.

SMB500: Optional Surface-Mount Backbox.

CB500: Control Module Barrier — required by UL for separating power-limited and non-power limited wiring in the same junction box as FCM-1(A).

NOTE: For installation instructions, see the following documents:

- *FCM-1(A) Installation document I56-1169.*
- *FRM-1(A) Installation document I56-3502.*
- *Notifier SLC Wiring Manual, document 51253.*

Notifier® and FlashScan® are registered trademarks of Honeywell International Inc.

©2011 by Honeywell International Inc. All rights reserved. Unauthorized use of this document is strictly prohibited.



This document is not intended to be used for installation purposes.
We try to keep our product information up-to-date and accurate.
We cannot cover all specific applications or anticipate all requirements.
All specifications are subject to change without notice.



Made in the U.S. A.

For more information, contact Notifier. Phone: (203) 484-7161, FAX: (203) 484-7118.
www.notifier.com

FMM-1(A), FMM-101(A), FZM-1(A) & FDM-1(A)

Monitor Modules with FlashScan®



Intelligent/Addressable Devices

General

Four different monitor modules are available for Notifier's intelligent control panels for a variety of applications. Monitor modules supervise a circuit of dry-contact input devices, such as conventional heat detectors and pull stations, or monitor and power a circuit of two-wire smoke detectors (FZM-1(A)).

FMM-1(A) is a standard-sized module (typically mounts to a 4" [10.16 cm] square box) that supervises either a Style D (Class A) or Style B (Class B) circuit of dry-contact input devices.

FMM-101(A) is a miniature monitor module a mere 1.3" (3.302 cm) H x 2.75" (6.985 cm) W x 0.65" (1.651 cm) D that supervises a Style B (Class B) circuit of dry-contact input devices. Its compact design allows the FMM-101(A) to be mounted in a single-gang box behind the device it monitors.

FZM-1(A) is a standard-sized module that monitors and supervises compatible two-wire, 24 volt, smoke detectors on a Style D (Class A) or Style B (Class B) circuit.

FDM-1(A) is a standard-sized dual monitor module that monitors and supervises two independent two-wire Style B (Class B) dry-contact initiating device circuits (IDCs) at two separate, consecutive addresses in intelligent, two-wire systems.

FlashScan® (U.S. Patent 5,539,389) is a communication protocol developed by NOTIFIER that greatly increases the speed of communication between analog intelligent devices. Intelligent devices communicate in a grouped fashion. If one of the devices within the group has new information, the panel CPU stops the group poll and concentrates on single points. The net effect is response speed greater than five times that of other communication protocols.

FMM-1(A) Monitor Module

- Built-in type identification automatically identifies this device as a monitor module to the control panel.
- Powered directly by two-wire SLC loop. No additional power required.
- High noise (EMF/RFI) immunity.
- SEMS screws with clamping plates for ease of wiring.
- Direct-dial entry of address: 01 – 159 on FlashScan loops; 01 – 99 on CLIP loops.
- LED flashes green during normal operation (programmable option) and latches on steady red to indicate alarm.

The FMM-1(A) Monitor Module is intended for use in intelligent, two-wire systems, where the individual address of each module is selected using the built-in rotary switches. It provides either a two-wire or four-wire fault-tolerant Initiating Device Circuit (IDC) for normally-open-contact fire alarm and supervisory devices. The module has a panel-controlled LED indicator. The FMM-1(A) can be used to replace MMX-1(A) modules in existing systems.

FMM-1(A) APPLICATIONS

Use to monitor a zone of four-wire smoke detectors, manual fire alarm pull stations, waterflow devices, or other normally-



FMM-1(A) (Type H)

open dry-contact alarm activation devices. May also be used to monitor normally-open supervisory devices with special supervisory indication at the control panel. Monitored circuit may be wired as an NFPA Style B (Class B) or Style D (Class A) Initiating Device Circuit. A 47K Ohm End-of-Line Resistor (provided) terminates the Style B circuit. No resistor is required for supervision of the Style D circuit.

FMM-1(A) OPERATION

Each FMM-1(A) uses one of the available module addresses on an SLC loop. It responds to regular polls from the control panel and reports its type and the status (open/normal/short) of its Initiating Device Circuit (IDC). A flashing LED indicates that the module is in communication with the control panel. The LED latches steady on alarm (subject to current limitations on the loop).

FMM-1(A) SPECIFICATIONS

Nominal operating voltage: 15 to 32 VDC.

Maximum current draw: 5.0 mA (LED on).

Average operating current: 375 µA (LED flashing), 1 communication every 5 seconds, 47K EOL.

Maximum IDC wiring resistance: 1500 Ohms.

Maximum IDC Voltage: 11 Volts.

EOL resistance: 47K Ohms.

Temperature range: 32°F to 120°F (0°C to 49°C).

Humidity range: 10% to 93% noncondensing.

Dimensions: 4.5" (11.43 cm) high x 4" (10.16 cm) wide x 1.25" (3.175 cm) deep. Mounts to a 4" (10.16 cm) square x 2.125" (5.398 cm) deep box.

FMM-101(A) Mini Monitor Module

- Built-in type identification automatically identifies this device as a monitor module to the panel.
- Powered directly by two-wire SLC loop. No additional power required.
- High noise (EMF/RFI) immunity.
- Tinned, stripped leads for ease of wiring.
- Direct-dial entry of address: 01 – 159 on FlashScan loops; 01 – 99 on CLIP loops.

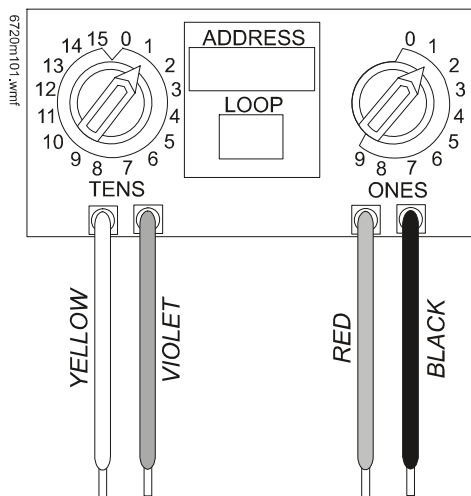

The FMM-101(A) Mini Monitor Module can be installed in a single-gang junction directly behind the monitored unit. Its small size and light weight allow it to be installed without rigid mounting. The FMM-101(A) is intended for use in intelligent, two-wire systems where the individual address of each module is selected using rotary switches. It provides a two-wire initiating device circuit for normally-open-contact fire alarm and security devices. The FMM-101(A) can be used to replace MMX-101(A) modules in existing systems.

FMM-101(A) APPLICATIONS

Use to monitor a single device or a zone of four-wire smoke detectors, manual fire alarm pull stations, waterflow devices, or other normally-open dry-contact devices. May also be used to monitor normally-open supervisory devices with special supervisory indication at the control panel. Monitored circuit/device is wired as an NFPA Style B (Class B) Initiating Device Circuit. A 47K Ohm End-of-Line Resistor (provided) terminates the circuit.

FMM-101(A) OPERATION

Each FMM-101(A) uses one of the available module addresses on an SLC loop. It responds to regular polls from the control panel and reports its type and the status (open/normal/short) of its Initiating Device Circuit (IDC).

FMM-101(A) SPECIFICATIONS

Nominal operating voltage: 15 to 32 VDC.

Average operating current: 350 μ A, 1 communication every 5 seconds, 47k EOL; 600 μ A Max. (Communicating, IDC Shorted).

Maximum IDC wiring resistance: 1500 Ohms.

Maximum IDC Voltage: 11 Volts.

Maximum IDC Current: 450 μ A.

EOL resistance: 47K Ohms.

Temperature range: 32°F to 120°F (0°C to 49°C).

Humidity range: 10% to 93% noncondensing.

Dimensions: 1.3" (3.302 cm) high x 2.75" (6.985 cm) wide x 0.65" (1.651 cm) deep.

Wire length: 6" (15.24 cm) minimum.

FZM-1(A) Interface Module

- Supports compatible two-wire smoke detectors.
- Supervises IDC wiring and connection of external power source.
- High noise (EMF/RFI) immunity.
- SEMS screws with clamping plates for ease of wiring.
- Direct-dial entry entry of address: 01 – 159 on FlashScan loops, 01 – 99 on CLIP loops.
- LED flashes during normal operation; this is a programmable option.
- LED latches steady to indicate alarm on command from control panel.

The FZM-1(A) Interface Module is intended for use in intelligent, addressable systems, where the individual address of each module is selected using built-in rotary switches. This module allows intelligent panels to interface and monitor two-wire conventional smoke detectors. It transmits the status (normal, open, or alarm) of one full zone of conventional detectors back to the control panel. All two-wire detectors being monitored must be UL compatible with the module. The FZM-1(A) can be used to replace MMX-2(A) modules in existing systems.

FZM-1(A) APPLICATIONS

Use the FZM-1(A) to monitor a zone of two-wire smoke detectors. The monitored circuit may be wired as an NFPA Style B (Class B) or Style D (Class A) Initiating Device Circuit. A 3.9 K Ohm End-of-Line Resistor (provided) terminates the end of the Style B or D (class B or A) circuit (maximum IDC loop resistance is 25 Ohms). Install ELR across terminals 8 and 9 for Style D application.

FZM-1(A) OPERATION

Each FZM-1(A) uses one of the available module addresses on an SLC loop. It responds to regular polls from the control panel and reports its type and the status (open/normal/short) of its Initiating Device Circuit (IDC). A flashing LED indicates that the module is in communication with the control panel. The LED latches steady on alarm (subject to current limitations on the loop).

FZM-1(A) SPECIFICATIONS

Nominal operating voltage: 15 to 32 VDC.

Maximum current draw: 5.1 mA (LED on).

Maximum IDC wiring resistance: 25 Ohms.

Average operating current: 270 μ A, 1 communication and 1 LED flash every 5 seconds, 3.9k eol.

EOL resistance: 3.9K Ohms.

External supply voltage (between Terminals T10 and T11):

- DC voltage: 24 volts power limited.
- Ripple voltage: 0.1 Vrms maximum.
- Current: 90 mA per module maximum.

Temperature range: 32°F to 120°F (0°C to 49°C).

Humidity range: 10% to 93% noncondensing.

Dimensions: 4.5" (11.43 cm) high x 4" (10.16 cm) wide x 1.25" (3.175 cm) deep. Mounts to a 4" (10.16 cm) square x 2.125" (5.398 cm) deep box.

FDM-1(A) Dual Monitor Module

The FDM-1(A) Dual Monitor Module is intended for use in intelligent, two-wire systems. It provides two independent two-wire initiating device circuits (IDCs) at two separate, consecutive addresses. It is capable of monitoring normally open contact fire alarm and supervisory devices; or either normally open or normally closed security devices. The module has a single panel-controlled LED.

NOTE: The FDM-1(A) provides two Style B (Class B) IDC circuits ONLY. Style D (Class A) IDC circuits are NOT supported in any application.

FDM-1(A) SPECIFICATIONS

Normal operating voltage range: 15 to 32 VDC.

Maximum current draw: 6.4 mA (LED on).

Average operating current: 750 μ A (LED flashing).

Maximum IDC wiring resistance: 1,500 Ohms.

Maximum IDC Voltage: 11 Volts.

Maximum IDC Current: 240 μ A

EOL resistance: 47K Ohms.

Temperature range: 32° to 120°F (0° to 49°C).

Humidity range: 10% to 93% (non-condensing).

Dimensions: 4.5" (11.43 cm) high x 4" (10.16 cm) wide x 1.25" (3.175 cm) deep. Mounts to a 4" (10.16 cm) square x 2.125" (5.398 cm) deep box.

FDM-1(A) AUTOMATIC ADDRESSING

The FDM-1(A) automatically assigns itself to two addressable points, starting with the original address. For example, if the FDM-1(A) is set to address "26", then it will automatically assign itself to addresses "26" and "27".

NOTE: "Ones" addresses on the FDM-1(A) are 0, 2, 4, 6, or 8 only. Terminals 6 and 7 use the first address, and terminals 8 and 9 use the second address.



CAUTION:

Avoid duplicating addresses on the system.

Installation

FMM-1(A), FZM-1(A), and FDM-1(A) modules mount directly to a standard 4" (10.16 cm) square, 2.125" (5.398 cm) deep, electrical box. They may also be mounted to the SMB500 surface-mount box. Mounting hardware and installation instructions are provided with each module. All wiring must conform to applicable local codes, ordinances, and regulations. These modules are intended for power-limited wiring only.

The FMM-101(A) module is intended to be wired and mounted without rigid connections inside a standard electrical box. All wiring must conform to applicable local codes, ordinances, and regulations.

Agency Listings and Approvals

In some cases, certain modules may not be listed by certain approval agencies, or listing may be in process. Consult factory for latest listing status.

- **UL:** S635.
- **ULC:** S635.
- **FM Approved.**
- **CSFM:** 7300-0028:0219, 7165-0028:0224, 7165-0028:0243.
- **MEA:** 457-99-E.
- **U.S. Coast Guard:** 161.002/50/0 (NFS2-640, NFS2-320, NFS2-3030).
- **Lloyd's Register:** 11/600013 (NFS2-640, NFS2-320, NFS2-3030).
- **Fire Dept. of New York:** COA #6121 (NFS2-640, NFS-320), COA# 6114 (NFS2-3030).

Product Line Information

NOTE: "A" suffix indicates ULC-listed model.

FMM-1(A): Monitor module.

FMM-101(A): Monitor module, miniature.

FZM-1(A): Monitor module, two-wire detectors.

FDM-1(A): Monitor module, dual, two independent Class B circuits.

SMB500: Optional surface-mount backbox.

NOTE: See installation instructions and refer to the SLC Wiring Manual, PN 51253.

FlashScan® and NOTIFIER® are registered trademarks and FireWatch™ is a trademark of Honeywell International Inc.
©2015 by Honeywell International Inc. All rights reserved. Unauthorized use of this document is strictly prohibited.



This document is not intended to be used for installation purposes.
We try to keep our product information up-to-date and accurate.
We cannot cover all specific applications or anticipate all requirements.
All specifications are subject to change without notice.

For more information, contact Notifier. Phone: (203) 484-7161, FAX: (203) 484-7118.
www.notifier.com

ISO-X(A)

Fault Isolator Module



Intelligent/Addressable Devices

General

The Notifier ISO-X(A) Fault Isolator Module is used with Notifier Onyx and CLIP series Fire Alarm Control Panels (FACPs) to protect the system against wire-to-wire short circuits on the SLC loops.

Features

- Powered by SLC loop directly, no external power required.
- Base mounts on standard junction boxes (4.0"/10.16 cm square by 2.125"/5.398 cm deep).
- Integral LED blinks to indicate normal condition. Illuminates steady when short circuit condition is detected.
- High noise (EMF/RFI) immunity.
- Wide viewing angle of LED.
- SEMS screws with clamping plates for ease of wiring.
- Opens SLC loop automatically on detection of short, preventing the short from causing failure of the entire loop.
- Automatically resets on correction of short.
- Supports Style 4, 6, or 7 wiring.

Applications

The Fault Isolator Modules should be spaced between groups of sensors in a loop to protect the rest of the loop. Use to isolate short circuit problems within a section of a loop so that other sections can continue to operate normally. The ISO-X(A) supports a maximum of 25 devices in-between isolators, except when using relay bases or legacy IPX multisensors.

NOTE: ON LOADS PER RELAY BASE AND LEGACY MULTI-SENSOR DETECTORS/ISOLATORS/ISOLATOR BASES: the maximum number of addressable devices between isolators (or B224BI isolator bases) is 25 devices.

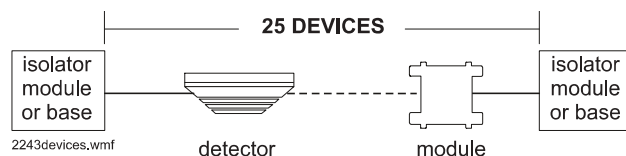

B224RB relay bases and legacy IPX-751 multisensor detectors draw more current than all other intelligent devices. When calculating the 25-device maximum: B224RB.

- B224RB represents 2.5 devices.
- IPX-751 in a standard base represents 12 devices.
- IPX-751 in a relay base represents 14.5 devices.
- All other addressable devices represent 1 device.

See examples on page 2.

NOTE: ON MAXIMUM NUMBER OF DEVICES: See the SLC Manual (PN 51253) for information on loss of addresses due to current limitations. Each module or base added reduces the capacity of address positions in an SLC. All SLC field devices must have been purchased after February 1995 to meet the aforementioned requirements. If the SLC field devices were purchased prior to February 1995, each ISO-X(A) used reduces the capacity of an SLC by two address positions. Requirements differ as applied to relay bases (see note above).

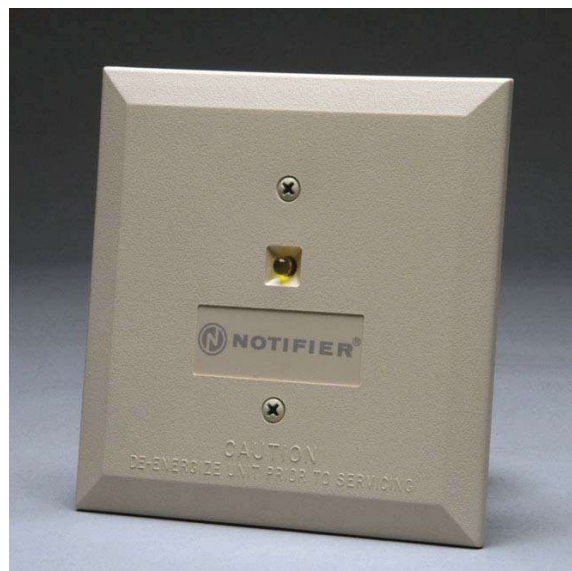

ISO-X(A)

Construction

The face plate is made of off-white plastic. Includes yellow LED indicator that pulses when normal and illuminates steady when a short is detected.

Operation

Automatically opens circuit when the line voltage drops below four volts. Fault Isolator Modules should be spaced between groups of addressable devices (maximum 25, see notes on page 1) in a loop to protect the rest of the loop. If a short occurs between any two isolators, then both isolators immediately switch to an open circuit state and isolate the groups of sensors between them. The remaining units on the loop continue to fully operate.

In Style 4 loops, the ISO-X(A) is generally used at each T-tap branch, to limit the effect of short circuits on a branch to the devices on that branch. The LED indicator is on continuously during a short circuit condition.

The ISO-X(A) Fault Isolator Module automatically restores the shorted portion of the communications loop to normal condition when the short circuit condition is removed.

Installation

- Mount on a standard junction box (4.0"/10.16 cm square) which is at least 2.125"/5.398 cm deep.
- Terminal screws are provided for "in and out" wiring.
- Installation instructions are provided with each module.
- Surface-mount box is available as an option.

Specifications

Normal operating voltage: 15 – 32 VDC (peak).

Standby current: 450 μ A (not isolating) .

Maximum current draw: 17 mA (device in isolation, LED latched in alarm).

Temperature range: 32°F to 120°F (0°C to 49°C).

Relative humidity: 10% to 93% (non-condensing).

Weight: 5 oz. (150 grams).

Dimensions: 4.5"H x 4.5"W x 0.25" D (11.43 cm H x 11.43 cm W x 0.635 cm D).

Agency Listings and Approvals

In some cases, certain modules may not be listed by certain approval agencies, or listing may be in process. Consult factory for latest listing status.

- **UL:** S635 (UOXX); BP6480 (AMCX, APOU).
- **ULC:** S635 (OUOXXC, ISO-XA).
- **FM Approved.**
- **CSFM:** 7165-0028:0214; 7165-0028:0224; 7165-0028:0243.
- **MEA:** 17-96-E; 104-93-E Vol. VI; 290-91-E Vol. V; 317-01-E; 447-99-E.
- **U.S. Coast Guard:** 161.002/42/1 (NFS-640); 161.002/50/0 (NFS2-640/NFS-320/NFS-320C, excluding B210LP(A)).
- **Lloyd's Register:** 11/600013 (NFS2-640/NFS-320/NFS-320C, excluding B210LP(A)).
- **BSA:** 578-81-SA.

Architectural/Engineering Specifications

Fault Isolator Modules shall be provided to automatically isolate wire-to-wire short circuits on an SLC loop. The Fault Isolator Module shall limit the number of modules or detectors that may be rendered inoperative by a short circuit fault on the SLC Loop. If a wire-to-wire short occurs, the Fault Isolator Module shall automatically open-circuit (disconnect) the SLC Loop. When the short circuit condition is corrected, the Fault Isolator Module shall automatically reconnect the isolated section of the SLC loop. The Fault Isolator Module shall not require any address-setting, and its operations shall be totally automatic. It shall not be necessary to replace or reset an Fault Isolator Module after its normal operation. The Fault Isolator Module shall mount in a standard 4.0" (10.16 cm) deep electrical box, in a surface-mounted backbox, or in the Fire Alarm Control Panel. It shall provide a single LED which shall flash to indicate that the Isolator is operational and shall illuminate steadily to indicate that a short circuit condition has been detected and isolated.

Product Line Information

NOTE: "A" suffix indicates ULC Listed model.

ISO-X: Isolator Module.

ISO-XA: Isolator Module. Canadian (ULC) version.

SMB500: Surface Mount Backbox

Examples of Device Counts

(see notes under *Applications*)

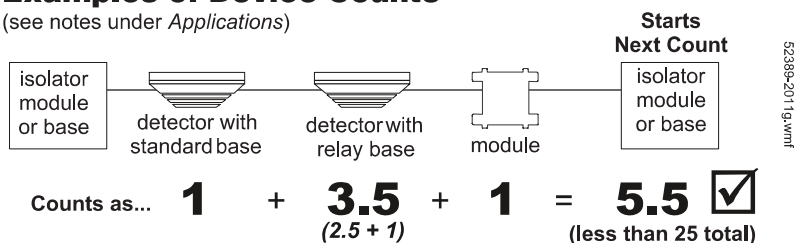

Notifier® is a registered trademark of Honeywell International Inc.
©2012 by Honeywell International Inc. All rights reserved. Unauthorized use of this document is strictly prohibited.



This document is not intended to be used for installation purposes.
We try to keep our product information up-to-date and accurate.
We cannot cover all specific applications or anticipate all requirements.
All specifications are subject to change without notice.



Made in the U.S. A.

For more information, contact Notifier. Phone: (203) 484-7161, FAX: (203) 484-7118.
www.notifier.com

NBG-12 Series

Non-Coded Conventional Manual Fire Alarm Pull Stations



Conventional Initiating Devices

General

The NOTIFIER **NBG-12 Series** is a cost-effective, feature-packed series of non-coded manual fire alarm pull stations. It was designed to meet multiple applications with the installer and end-user in mind. The NBG-12 Series features a variety of models including single- and dual-action versions.

The NBG-12 Series provides an alarm initiating input signal to conventional fire alarm control panels (FACPs) such as the SFP Series, and to XP Transponders. Its innovative design, durable construction, and multiple mounting options make the NBG-12 Series simple to install, maintain, and operate.

Features

- Aesthetically pleasing, highly visible design and color.
- Attractive contoured shape and light textured finish.
- Meets ADA 5 lb. maximum pull-force.
- Meets UL 38, Standard for Manually Actuated Signaling Boxes.
- Easily operated (single- or dual-action, model dependent), yet designed to prevent false alarms when bumped, shaken, or jarred.
- PUSH IN/PULL DOWN handle latches in the down position to clearly indicate the station has been operated.
- The word "ACTIVATED" appears on top of the handle in bright yellow, further indicating operation of the station.
- Operation handle features white arrows showing basic operation direction for non-English-speaking persons.
- Braille text included on finger-hold area of operation handle and across top of handle.
- Multiple hex- and key-lock models available.
- U.S. patented hex-lock needs only a quarter-turn to lock/unlock.
- Station can be opened for inspection and maintenance without initiating an alarm.
- Product ID label viewable by simply opening the cover; label is made of a durable long-life material.
- The words "NORMAL" and "ACTIVATED" are molded into the plastic adjacent to the alarm switch (located inside).
- Four-position terminal strip molded into backplate.
- Terminal strip includes Phillips combination-head captive 8/32 screws for easy connection to Initiating Device Circuit (IDC).
- Terminal screws backed-out at factory and shipped ready to accept field wiring (up to 12 AWG/3.1 mm²).
- Terminal numbers are molded into the backplate, eliminating the need for labels.
- Switch contacts are normally open.
- Can be surface-mounted (with **SB-10** or **SB-I/O**) or semi-flush mounted. Semi-flush mount to a standard single-gang, double-gang, or 4" (10.16 cm) square electrical box.
- Backplate is large enough to overlap a single-gang backbox cutout by 1/2" (1.27 cm).
- Optional trim ring (**BG12TR**).
- Spanish versions (*FUEGO*) available (**NBG-12LSP**, **NBG-12LPSP**).
- Designed to replace the legacy **NBG-10** Series.
- Models packaged in attractive, clear plastic (PVC), clam-shell-style, Point-of-Purchase packages. Packaging includes a cutaway dust/paint cover in shape of pull station.



6643cov.jpg

Construction

- Cover, backplate and operation handle are all molded of durable polycarbonate material.
- Cover features white lettering and trim.
- Red color matches System Sensor's popular SpectrAlert® Advance horn/strobe series.

Operation

The NBG-12 manual pull stations provide a textured finger-hold area that includes Braille text. In addition to PUSH IN and PULL DOWN text, there are arrows indicating how to operate the station, provided for non-English-speaking people.

Pushing in and then pulling down on the handle activates the normally-open alarm switch. Once latched in the down position, the word "ACTIVATED" appears at the top in bright yellow, with a portion of the handle protruding at the bottom as a visible flag. Resetting the station is simple: insert the key or hex (model dependent), twist one quarter-turn, then open the station's front cover, causing the spring-loaded operation handle to return to its original position. The alarm switch can then be reset to its normal (non-alarm) position manually (by hand) or by closing the station's front cover, which automatically resets the switch.

Specifications

PHYSICAL SPECIFICATIONS:

	pull station	SB-10	SB-I/O	WBB	WP-10
H	5.500 in. (13.97 cm)	5.500 in. (13.97 cm)	5.601 in. (14.23 cm)	4.25 in. (10.79 cm)	6.000 in. (15.24 cm)
W	4.121 in. (10.467 cm)	4.125 in. (10.478 cm)	4.222 in. (10.72 cm)	4.25 in. (10.79 cm)	4.690 in. (11.913 cm)
D	1.390 in. (3.531 cm)	1.375 in. (3.493 cm)	1.439 in. (3.66 cm)	1.75 in. (4.445 cm)	2.000 in. (5.08 cm)

6643dim2.tbl

ELECTRICAL SPECIFICATIONS:

Switch contact ratings: gold-plated; rating 0.25 A @ 30 VAC or VDC. **Auxiliary contact circuit** (Terminals 3 & 4, NBG-12LA): rated to 3.0 A @ 30 VAC or VDC.

ENGINEERING/ARCHITECTURAL SPECIFICATIONS

Manual Fire Alarm Stations shall be non-code, with a key- or hex-operated reset lock in order that they may be tested, and so designed that after actual Emergency Operation, they cannot be restored to normal except by use of a key or hex. An operated station shall automatically condition itself so as to be visually detected as activated. Manual stations shall be constructed of red colored LEXAN (or polycarbonate equivalent) with clearly visible operating instructions provided on the cover. The word **FIRE** shall appear on the front of the stations in white letters, 1.00 inches (2.54 cm) or larger.* Stations shall be suitable for surface mounting on matching backbox SB-10 or SB-I/O; or semi-flush mounting on a standard single-gang, double-gang, or 4" (10.16 cm) square electrical box, and shall be installed within the limits defined by the Americans with Disabilities Act (ADA) or per national/local requirements. Manual Stations shall be Underwriters Laboratories listed.

NOTE: *The words "FIRE/FUEGO" on the NBG-12LSP and NBG-12LPSP shall appear on the front of the station in white letters, approximately 3/4" (1.905 cm) high.

Pre-Signal Models

The NBG-12LPS and NBG-12LPSP pull stations are non-coded manual pull stations which provide a FACP with two normally open alarm initiating input signals. "Pre-signal" input is activated by pushing in, then pulling down, the dual-action handle. A "general" alarm input signal can be manually activated via a momentary rocker switch mounted inside the unit. This general alarm switch can only be accessed by opening the cover with the supplied key/lock. See diagram at right.

Agency Listings and Approvals

The listings and approvals below apply to the NBG-12 Series pull stations. In some cases, certain modules may not be listed by certain approval agencies, or listing may be in process. Consult factory for latest listing status.

- **C(UL)US** Listed: file S692.
- **CSFM** approved: file 7150-0028:199.
- **FM** approved (except NBG-12LPS, NBG-12LPSP).
- **MEA** approved: file 67-02-E (NBG-12, NBG-12L, NBG-12LOB, NBG-12LA).
- **Lloyd's Register** type approved: file 93/60141 (E3) (NBG-12, NBG-12L, NBG-12LA, NBG-12LOB, NBG-12S).
- **U.S. Coast Guard** approved: files 161.002/23/3 (AFP-200 with NBG-12, NBG-12L, NBG-12S); 161.002/42/1 (NFS-640 with NBG-12, NBG-12L, NBG-12S); 161.002/27/3 (AFP1010/AM2020 with NBG-12, NBG-12L, NBG-12S).
- **Patented:** U.S. Patent No. D428,351; 6,380,846; 6,314,772; 6,632,108.

Product Line Information

NBG-12S: Single-action pull station with pigtail connections, hex lock.

NBG-12: Dual-action pull station with SPST N/O switch, screw terminal connections, **hex lock**.

NBG-12L: Dual-action pull station with SPST N/O switch, screw terminal connections, **key lock**.

NBG-12LSP: Same as NBG-12L with English/Spanish (FIRE/FUEGO) labeling.

NBG-12LPS: Dual-action pull station with pre-signal option.

NBG-12LPSP: Same as NBG-12LPS with English/Spanish (FIRE/FUEGO) labeling.

NBG-12LOB: Dual-action pull station with key lock, outdoor applications listings (NBG-12LO), and backbox. Includes SB-I/O indoor/outdoor backbox, and sealing gasket. Model will also mount to WP-10 weatherproof backbox in retrofit applications.

NOTE: NBG-12LO not available separately;

NBG-12LO + approved backbox = NBG-12LOB.

Outdoor applications listings apply to NBG-12LOB combination.

NBG-12LA: Dual-action pull station with key lock and annunciator contacts.

SB-10: Surface-mount backbox, metal.

SB-I/O: Surface-mount backbox, plastic. (Included with NBG-12LOB.)

BG12TR: Optional trim ring for semi-flush mounting.

WP-10: Outdoor use backbox.

17021: Keys, set of two. (Included with key-lock pull stations.)

17007: Hex key, 9/64". (Included with hex-lock pull stations.)

NOTE: For addressable NBG-12LX models, see data sheet DN-6726.

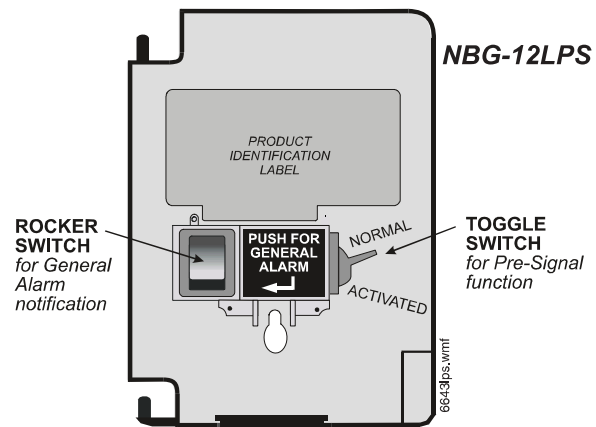
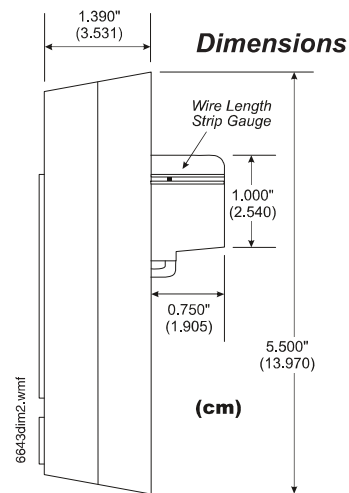

NOTIFIER®, SpectrAlert® Advance, and System Sensor® are registered trademarks of Honeywell International Inc. ©2008 by Honeywell International Inc. All rights reserved. Unauthorized use of this document is strictly prohibited.



This document is not intended to be used for installation purposes. We try to keep our product information up-to-date and accurate. We cannot cover all specific applications or anticipate all requirements. All specifications are subject to change without notice.



Made in the U.S.A.

For more information, contact Notifier. Phone: (203) 484-7161, FAX: (203) 484-7118. www.notifier.com



System Sensor
3825 Ohio Avenue
St. Charles, IL 60174
www.systemsensor.com

June 2024

Product Announcement: L-Series with LED Indoor Speaker Strobes, Outdoor Strobes, Outdoor Horn Strobes and L-Series Outdoor Horns Now Available

System Sensor is pleased to announce the next phase of the L-Series audible visible notification appliance line with the availability of L-Series with LED indoor speaker strobes plus an all-new next generation of weatherproof notification appliances with the availability of L-Series outdoor horns and L-Series with LED outdoor strobes and horn strobes.

The new L-Series outdoor weatherproof devices offer significant improvements in current draw and power supply utilization compared to previous generation SpectrAlert Advance outdoor appliances. In addition, all L-Series outdoor notification appliances are NEMA 4X and IP56 rated without having to seal the backbox. Additional caulk and sealant are not required on the backbox allowing for a faster, cleaner installation. Plus, leveraging LED technology for the strobe devices improves design flexibility for notification appliance circuits (NACs) while also reducing power supply requirements, allowing for simpler and lower-cost installations.

L-Series with LED Indoor Speaker Strobes Technical and Design Features:

- 40% lower current draw (on average) reduces power supplies and allows more devices per NAC
- DVM test points eliminate the need to remove appliance from wall or ceiling to measure voltage
- Unmatched application versatility with:
 - Wall and ceiling-mount models
 - Red or white color options
 - Common LED lenses
- Compatibility with legacy System Sensor SpectrAlert, SpectrAlert Advance, and L-Series notification appliances for retrofit applications
- Common L-Series design aesthetic for continuity with existing L-Series installations
- Dual-listed with both UL and ULC certifications

L-Series with LED Outdoor Strobes, Horn Strobes and L-Series Outdoor Horns Technical and Design Features:

- 60% lower current draw (on average) reduces power supplies and allows more devices per NAC
- NEMA 4X and IP56 rating as standalone devices
- Unmatched application versatility with:
 - Full candela range
 - Wall and ceiling-mount models
 - Compact size for wall-mount devices
 - Red or white color options
 - Common LED lenses
- Compatibility with legacy System Sensor SpectrAlert and SpectrAlert Advance notification appliances for retrofit applications
- Common L-Series design aesthetic for both indoor and outdoor devices
- Dual-listed with both UL and ULC certifications

Additional indoor strobe appliances, including chime strobes and 4-wire horn strobes, as well as outdoor speaker strobes, will convert to the new L-Series with LED platform while outdoor speakers will convert to the L-Series platform in the coming months. Look for future launch announcements about the availability of these additional L-Series and L-Series with LED devices coming soon.

The L-Series with LED indoor speaker strobes, outdoor strobes, outdoor horn strobes and L-Series outdoor horns are available to order now! Log into your [MyBuildings](#) eCommerce account or contact your Customer Service Representative at fire.orders.us@honeywell.com to order today.

Please note that the legacy L-Series indoor speaker strobes and SpectrAlert Advance horns, strobes, and horn strobes will continue to be offered until October 1st, 2024, or while supplies last.

Thank you for your business and continued support of System Sensor products.

Sameer Nakai | Sr. Offering Manager | System Sensor

New Models Now Available:

MODEL NO.	DESCRIPTION	REPLACES
INDOOR SPEAKER STROBES		
SPSCRLED	LED SPEAKER STROBE; CEILING; RED; FIRE	SPSCRL
SPSCWLED-CLR-ALERT	LED SPEAKER STROBE; CEILING; WHITE; ALERT	SPSCWL-CLR-ALERT
SPSCWLED	LED SPEAKER STROBE; CEILING; WHITE; FIRE	SPSCWL
SPSCWLED-SP	LED SPEAKER STROBE; CEILING; WHITE; FUEGO	SPSCWL-SP
SPSCWLED-P	LED SPEAKER STROBE; CEILING; WHITE; PLAIN	SPSCWL-P
SPSRLED	LED SPEAKER STROBE; WALL; RED; FIRE	SPSRL
SPSRLED-SP	LED SPEAKER STROBE; WALL; RED; FUEGO	SPSRL-SP
SPSRLED-P	LED SPEAKER STROBE; WALL; RED; PLAIN	SPSRL-P
SPSWLED-CLR-ALERT	LED SPEAKER STROBE; WALL; WHITE; ALERT	SPSWL-CLR-ALERT
SPSWLED-ALERT	LED SPEAKER STROBE; WALL; WHITE; ALERT; AMBER LENS	SPSWL-ALERT
SPSWLED	LED SPEAKER STROBE; WALL; WHITE; FIRE	SPSWL
SPSWLED-P	LED SPEAKER STROBE; WALL; WHITE; PLAIN	SPSWL-P
OUTDOOR STROBES		
SCRKLED	OUTDOOR LED STROBE; CEILING; RED; FIRE	SCRK; SCRHK
SCRKLED-P	OUTDOOR LED STROBE; CEILING; RED; PLAIN	N/A
SCWKLED	OUTDOOR LED STROBE; CEILING; WHITE; FIRE	SCWK; SCWHK
SCWKLED-P	OUTDOOR LED STROBE; CEILING; WHITE; PLAIN	N/A
SGRKLED	OUTDOOR LED STROBE; WALL; COMPACT; RED; FIRE	SRK; SRHK
SGRKLED-P	OUTDOOR LED STROBE; WALL; COMPACT; RED; PLAIN	SRK-P; SRHK-P
SGWKLED	OUTDOOR LED STROBE; WALL; COMPACT; WHITE; FIRE	SWK; SWHK
SGWKLED-P	OUTDOOR LED STROBE; WALL; COMPACT; WHITE; PLAIN	SWK-P; SWHK-P
OUTDOOR HORN STROBES		
PC2WKLED	OUTDOOR LED HORN STROBE; CEILING; WHITE; FIRE	PC2WK; PC2WHK
PC2RKLED	OUTDOOR LED HORN STROBE; CEILING; RED; FIRE	PC2RK; PC2RHK
PC2RKLED-P	OUTDOOR LED HORN STROBE; CEILING; RED; PLAIN	N/A
PC2WKLED-P	OUTDOOR LED HORN STROBE; CEILING; WHITE; PLAIN	N/A
P2GRKLED	OUTDOOR LED HORN STROBE; WALL; COMPACT; RED; FIRE	P2RK; P2RHK
P2GRKLED-P	OUTDOOR LED HORN STROBE; WALL; COMPACT; RED; PLAIN	P2RK-P; P2RHK-P
P2GWKLED	OUTDOOR LED HORN STROBE; WALL; COMPACT; WHITE; FIRE	P2WK; P2WHK
P2GWKLED-P	OUTDOOR LED HORN STROBE; WALL; COMPACT; WHITE; PLAIN	P2WK-P; P2WHK-P
OUTDOOR HORN		
HGRKL	OUTDOOR HORN; WALL; COMPACT; RED; FIRE	HRK



Outdoor Selectable-Output Horns, Strobes, and Horn Strobes for Wall Applications

SpectrAlert® Advance outdoor audible visible products are rich with features that cut installation times and maximize profits.



Features

- Weatherproof per NEMA 4X, IP56
- Listed to UL 1638 (strobe) and UL 464 (horn)
- Compatible with System Sensor synchronization protocol and legacy SpectrAlert products
- Field-selectable candela settings: 15, 15/75, 30, 75, 95, 110, 115, 135, 150, 177, and 185
- Automatic selection of 12- or 24-volt operation at 15 and 15/75 candela
- Rotary switch for horn tone and three volume selections
- Horn rated at 88+ dBA at 16 volts
- Rated from -40°F to 151°F
- Universal mounting plate with an onboard shorting spring that tests wiring continuity before devices are installed
- Plug-in design with minimal intrusion into the back box
- Tamper-resistant construction
- Listed for ceiling or wall mounting

Agency Listings



S4011 (chimes, horn strobes, horns)
S3593 (outdoor and alert strobes)



3023572



MEA452-05-E



7300-1653-187 (outdoor strobes)
7125-1653-188 (horn strobes,
chime strobes)
7135-1653-189 (horns, chimes)

SpectrAlert Advance offers the broadest line of outdoor horns, strobes, and horn strobes in the industry. With white or red plastic housings, wall or ceiling mounting options, and plain or FIRE-printed devices, SpectrAlert Advance can meet virtually any application requirement, including indoor, outdoor, wet, and dry applications in temperatures from -40°F to 151°F.

Like the entire SpectrAlert Advance line, outdoor horns, strobes, and horn strobes for wall applications include a variety of features that increase application flexibility and simplify installation. First, field-selectable settings, including candela, automatic selection of 12- or 24-volt operation, horn tones, and three volume options enable installers to easily adapt devices to meet requirements.

Next, SpectrAlert Advance devices use a universal mounting plate for both wall and ceiling applications. This mounting plate includes an onboard shorting spring that ensures wiring continuity before devices are installed, so installers can verify proper wiring without mounting the devices and exposing them to potential construction damage. Once the plates are mounted, all SpectrAlert Advance devices utilize a plug-in design with a single captured screw to speed installation and virtually eliminate costly ground faults.

Outdoor devices ship with weatherproof plastic back boxes (metal back boxes are available separately) that accommodate in-and-out wiring for daisy chaining devices. Plastic back boxes feature removable side flanges and improved resistance to saltwater corrosion. Knock-outs located on the back eliminate the need to drill holes for screw-in mounting. Plastic and metal weatherproof back boxes come with 3/4-inch top and bottom conduit entries and 3/4-inch knock-outs at the back. A screw-in NPT plug with an O-ring gasket for a watertight seal is included with each back box.

SpectrAlert Advance Outdoor Horn, Strobe, and Horn Strobe Specifications

Architect/Engineer Specifications

General

SpectrAlert Advance outdoor horns, strobes, and horn strobes shall mount to a weatherproof back box. A universal mounting plate shall be used for mounting ceiling and wall products. The notification appliance circuit wiring shall terminate at the universal mounting plate. Also, SpectrAlert Advance products, when used with the Sync•Circuit™ Module accessory, shall be powered from a non-coded notification appliance circuit output and shall operate on a nominal 12 or 24 volts. When used with the Sync•Circuit Module, 12-volt-rated notification appliance circuit outputs shall operate between 9 and 17.5 volts; 24-volt-rated notification appliance circuit outputs shall operate between 17 and 33 volts. Outdoor SpectrAlert Advance products shall operate between –40 and 151 degrees Fahrenheit from a regulated DC or full-wave rectified unfiltered power supply. Strobes and horn strobes shall have field-selectable candela settings including 15, 15/75, 30, 75, 95, 110, 115, 135, 150, 177, and 185.

Strobe

The strobe shall be a System Sensor SpectrAlert Advance Model _____ listed to UL 1971 and shall be approved for fire protective service. The strobe shall be wired as a primary-signaling notification appliance and comply with the Americans with Disabilities Act requirements for visible signaling appliances, flashing at 1 Hz over the strobe's entire operating voltage range. The strobe light shall consist of a xenon flash tube and associated lens/reflector system. The strobe must be installed with its weatherproof back box in order to remain outdoor approved per UL. The strobe shall be suitable for use in wet environments.

Horn Strobe Combination

The horn strobe shall be a System Sensor SpectrAlert Advance Model _____ listed to UL 1971 and UL 464 and shall be approved for fire protective service. The horn strobe shall be wired as a primary-signaling notification appliance and comply with the Americans with Disabilities Act requirements for visible signaling appliances, flashing at 1 Hz over the strobe's entire operating voltage range. The strobe light shall consist of a xenon flash tube and associated lens/reflector system. The horn shall have three audibility options and an option to switch between a temporal three pattern and a non-temporal (continuous) pattern. These options shall be set by a multiple position switch. On four-wire products, the strobe shall be powered independently of the sounder. The horn or horn strobe models shall operate on a coded or non-coded power supply. The horn strobe must be installed with its weatherproof back box in order to remain outdoor approved per UL. The horn strobe shall be suitable for use in wet environments.

Physical/Electrical Specifications

Operating Temperature	–40°F to 151°F (–40°C to 66°C)
Strobe Flash Rate	1 flash per second
Nominal Voltage	Regulated 12 DC/FWR or regulated 24 DC/FWR ¹
Operating Voltage Range²	8 to 17.5 V (12 V nominal) or 16 to 33 V (24 V nominal)
Input Terminal Wire Gauge	12 to 18 AWG
Wall-Mount Dimensions (including lens)	5.6" L × 4.7" W × 2.5" D (142 mm L × 119 mm W × 64 mm D)
Horn Dimensions	5.6" L × 4.7" W × 1.3" D (142 mm L × 119 mm W × 33 mm D)
Wall-Mount Weatherproof Back Box Dimensions (SA-WBB)	5.7" L × 5.1" W × 2.0" D (145 mm L × 130 mm W × 51 mm D)

Notes:

1. Full Wave Rectified (FWR) voltage is a non-regulated, time-varying power source that is used on some power supply and panel outputs.
2. P, S, PC, and SC products will operate at 12 V nominal only for 15 and 15/75 cd.

UL Current Draw Data

UL Max. Strobe Current Draw (mA RMS)						UL Max. Horn Current Draw (mA RMS)					
	Candela	8–17.5 Volts		16–33 Volts		Sound Pattern	dB	8–17.5 Volts		16–33 Volts	
		DC	FWR	DC	FWR			DC	FWR	DC	FWR
Standard Candela Range	15	123	128	66	71	Temporal	High	57	55	69	75
	15/75	142	148	77	81	Temporal	Medium	44	49	58	69
	30	NA	NA	94	96	Temporal	Low	38	44	44	48
	75	NA	NA	158	153	Non-Temporal	High	57	56	69	75
	95	NA	NA	181	176	Non-Temporal	Medium	42	50	60	69
	110	NA	NA	202	195	Non-Temporal	Low	41	44	50	50
	115	NA	NA	210	205	Coded	High	57	55	69	75
High Candela Range	135	NA	NA	228	207	Coded	Medium	44	51	56	69
	150	NA	NA	246	220	Coded	Low	40	46	52	50
	177	NA	NA	281	251						
	185	NA	NA	286	258						

UL Max. Current Draw (mA RMS), 2-Wire Horn Strobe, Standard Candela Range (15–115 cd)									
DC Input	8–17.5 Volts			16–33 Volts					
	15	15/75	15	15/75	30	75	95	110	115
Temporal High	137	147	79	90	107	176	194	212	218
Temporal Medium	132	144	69	80	97	157	182	201	210
Temporal Low	132	143	66	77	93	154	179	198	207
Non-Temporal High	141	152	91	100	116	176	201	221	229
Non-Temporal Medium	133	145	75	85	102	163	187	207	216
Non-Temporal Low	131	144	68	79	96	156	182	201	210
FWR Input									
Temporal High	136	155	88	97	112	168	190	210	218
Temporal Medium	129	152	78	88	103	160	184	202	206
Temporal Low	129	151	76	86	101	160	184	194	201
Non-Temporal High	142	161	103	112	126	181	203	221	229
Non-Temporal Medium	134	155	85	95	110	166	189	208	216
Non-Temporal Low	132	154	80	90	105	161	184	202	211

UL Max. Current Draw (mA RMS), 2-Wire Horn Strobe, High Candela Range (135–185 cd)									
DC Input	16–33 Volts				FWR Input	16–33 Volts			
	135	150	177	185		135	150	177	185
Temporal High	245	259	290	297	Temporal High	215	231	258	265
Temporal Medium	235	253	288	297	Temporal Medium	209	224	250	258
Temporal Low	232	251	282	292	Temporal Low	207	221	248	256
Non-Temporal High	255	270	303	309	Non-Temporal High	233	248	275	281
Non-Temporal Medium	242	259	293	299	Non-Temporal Medium	219	232	262	267
Non-Temporal Low	238	254	291	295	Non-Temporal Low	214	229	256	262

Candela Derating

For K series products used at low temperatures, listed candela ratings must be reduced in accordance with this table.

Strobe Output (cd)	
Listed Candela	Candela rating at –40°F
15	Do not use below 32°F
15/75	
30	
75	
95	44
110	70
115	110
135	135
150	150
177	177
185	185

Horn Tones and Sound Output Data

Horn and Horn Strobe Output (dBA)											
Switch Position	Sound Pattern	dB	8–17.5 Volts		16–33 Volts		24-Volt Nominal				
			DC	FWR	DC	FWR	Reverberant		Anechoic		
			DC	FWR	DC	FWR	DC	FWR	DC	FWR	
1	Temporal	High	78	78	84	84	88	88	99	98	
2	Temporal	Medium	74	74	80	80	86	86	96	96	
3	Temporal	Low	71	73	76	76	83	80	94	89	
4	Non-Temporal	High	82	82	88	88	93	92	100	100	
5	Non-Temporal	Medium	78	78	85	85	90	90	98	98	
6	Non-Temporal	Low	75	75	81	81	88	84	96	92	
7†	Coded	High	82	82	88	88	93	92	101	101	
8†	Coded	Medium	78	78	85	85	90	90	97	98	
9†	Coded	Low	75	75	81	81	88	85	96	92	

†Settings 7, 8, and 9 are not available on 2-wire horn strobe.

SpectrAlert Advance Diagrams

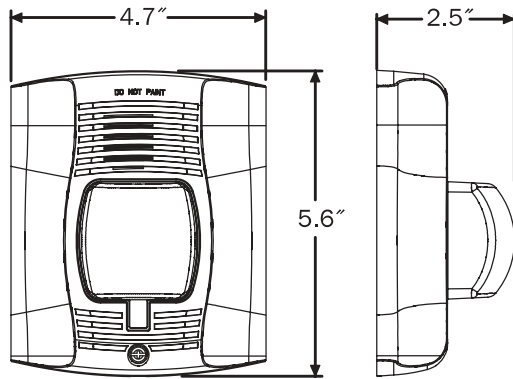

Wall-Mount Horn Strobes

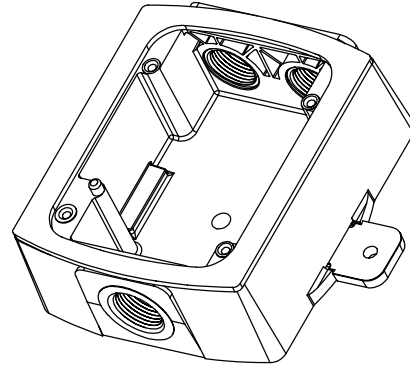

Wall Plastic Weatherproof Back Box

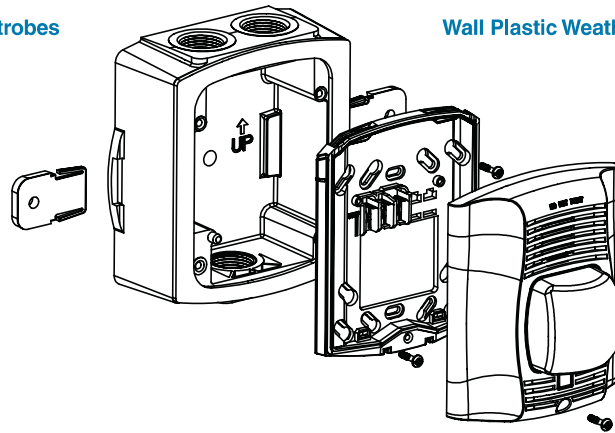

Wall-Mount Horn Strobe with Plastic Weatherproof Back Box

SpectrAlert Advance Ordering Information

Model	Description
Wall Horn Strobes	
P2RK*†	2-Wire Horn Strobe, Standard cd, Red, Outdoor (includes plastic weatherproof back box)
P2RHK*†	2-Wire Horn Strobe, High cd, Red, Outdoor (includes plastic weatherproof back box)
P2WK*†	2-Wire Horn Strobe, Standard cd, White, Outdoor (includes plastic weatherproof back box)
P2WHK*†	2-Wire Horn Strobe, High cd, White, Outdoor (includes plastic weatherproof back box)
P4RK†	4-Wire Horn Strobe, Standard cd, Red, Outdoor (includes plastic weatherproof back box)
P4WK	4-Wire Horn Strobe, Standard cd, White, Outdoor (includes plastic weatherproof back box)
P2RHK-120	2-Wire Horn Strobe, High cd, Red, Outdoor, 120 V (includes plastic weatherproof back box)
Wall Strobes	
SRK*†	Strobe, Standard cd, Red, Outdoor (includes plastic weatherproof back box)
SRHK*†	Strobe, High cd, Red, Outdoor (includes plastic weatherproof back box)
SWK*†	Strobe, Standard cd, White, Outdoor (includes plastic weatherproof back box)
SWHK*†	Strobe, High cd, White, Outdoor (includes plastic weatherproof back box)
Horns	
HRK†	Horn, Red, Outdoor (includes plastic weatherproof back box)
Accessories	
SA-WBB	Red, Metal Weatherproof Back Box
SA-WBBW	White, Metal Weatherproof Back Box

Notes:

* Add "-P" to model number for plain housing (no "FIRE" marking on cover), e.g., P2RK-P.

† Add "-R" to model number for weatherproof replacement device (no back box included), only for use with weatherproof outdoor flush mounting plate, WTP and WTPW. "Standard cd" refers to strobes that include 15, 15/75, 30, 75, 95, 110, and 115 candela settings. "High cd" refers to strobes that include 135, 150, 177, and 185 candela settings. **When replacing standard outdoor units both the device and back box must be replaced.**



3825 Ohio Avenue • St. Charles, IL 60174
Phone: 800-SENSOR2 • Fax: 630-377-6495

©2012 System Sensor.
Product specifications subject to change without notice. Visit systemsensor.com
for current product information, including the latest version of this data sheet.
AVDS01201 • 3/12



L-Series and L-Series with LED Indoor Selectable Horns, Strobes and Horn Strobes

System Sensor L-Series and L-Series with LED audible visible notification products are rich with features guaranteed to cut installation times and maximize profits with lower current draw and modern aesthetics.



Features

- LED technology provides lower current draw
- Digital Voltage Meter (DVM) diagnostic test points for Horn Strobes and Strobes
- Common aesthetics across the L-Series platform
- Standard and compact sizes
- Tamper-resistant construction
- Field-selectable candela settings on wall units: 15, 30, 75, 95, 110, 135, and 185
- Field-selectable candela settings on ceiling units: 15, 30, 75, 95, 115, 150, and 177
- Rotary switches for candela, tone and volume selections
- Mounting plate provides plug-in design for easier installation and shorting springs to check wiring continuity
- Electrically compatible with legacy SpectrAlert, SpectrAlert Advance and L-series devices
- Synchronization through use of UL approved power supplies that support System Sensor Sync protocol or System Sensor MDL3 Sync Module
- Horns, Strobes and Horn Strobes listed for wall or ceiling use

Agency Listings



The System Sensor L-Series and L-Series with LED

platform offers the most versatile and easy-to-use line of horns, strobes, and horn strobes in the industry with lower current draw and modern aesthetics. LED lighting technology offers significantly lower current draw compared to older Xenon bulbs across a full candela range. This improves design flexibility for notification appliance circuits (NACs) while also reducing power supply requirements allowing for simpler and lower cost installations.

Flexible design options meet virtually any application requirement: wall or ceiling mount, standard or compact sizes, red or white color choices, bezel kits for alternate markings and languages, and LED color lenses for distinctive visual signaling. In addition, installers can easily adapt devices using field selectable candela, tone and volume settings using rotary switches.

The L-Series and L-Series with LED line is developed to simplify installation. All devices feature plug-in designs with minimal intrusion into the back box, making installations fast and foolproof while virtually eliminating costly and time-consuming ground faults. The universal mounting plate includes an onboard shorting spring, so installers can test wiring continuity before the device is installed.

In addition, the System Sensor L-Series with LED notification appliances offer a new diagnostic test point feature that allows you to measure device voltage with a digital voltage meter (DVM) without removing the appliance from the wall or ceiling. The DVM test points are discreetly located on the face of the notification appliance which enable faster troubleshooting and end of line (EOL) voltage checks while greatly reducing the risk of misplacing or damaging appliances during troubleshooting.

L-Series and L-Series with LED Specifications

Physical/Electrical Specifications	
Standard Operating Temperature	32°F to 120°F (0°C to 49°C)
Humidity Range	10 to 93% non-condensing
Strobe Flash Rate	1 flash per second
Nominal Voltage, LED Strobes and Horn Strobes	Regulated 24 VDC
Nominal Voltage, Horns	Regulated 12 VDC or regulated 24 DC/FWR
Operating Voltage Range, LED Strobes and Horn Strobes	16 to 33 V (24 V nominal)
Operating Voltage Range, Horns	8 to 17.5 V (12 V nominal) or 16 to 33 V (24 V nominal)
Input Terminal Wire Gauge	12 to 18 AWG

UL/ULC Current Draw Data, Horn Tones, and Sound Output Data

Candela Range	UL/ULC Maximum Strobe Current Draw (mA)		
	Candela Rating	16–33 Volts	
		Wall	Ceiling
	15	18	18
	30	22	22
	75	70	70
	95	75	75
	110	85	—
	115	—	90
	135	105	—
	150	—	110
	177	—	115
	185	120	—

Sound Pattern	dB	UL/ULC Maximum Horn Current Draw (mA RMS)		
		8–17.5 Volts		16–33 Volts
		DC	DC	FWR
Temporal	High	39	44	54
Temporal	Low	28	32	54
Non-Temporal	High	43	47	54
Non-Temporal	Low	29	32	54
3.1 KHz Temporal	High	39	41	54
3.1 KHz Temporal	Low	29	32	54
3.1 KHz Non-Temporal	High	42	43	54
3.1 KHz Non-Temporal	Low	28	29	54
Coded	High	43	47	54
3.1 KHz Coded	High	42	43	54

UL/ULC Maximum Horn Strobe Current Draw (mA) and Sound Output (dBA)														
Switch Pos.	Sound Pattern	Volume Setting	Current Draw (mA RMS), Horn Strobe, Candela Range (15-185 cd)										Sound Output (dBA)	
			16-33 Volts											16-33V DC
			15cd	30cd	75cd	95cd	110cd	115cd	135cd	150cd	177cd	185cd		
			WALL	CEILING	WALL	CEILING	CEILING	WALL						
1	Temporal 3	High	35	38	87	92	94	120	189	189	190	190	87	
2	Temporal 3	Low	35	38	87	92	94	120	135	135	145	145	79	
3	Non-Temporal	High	50	52	87	92	94	120	127	127	135	135	87	
4	Non-Temporal	Low	35	38	87	92	94	120	125	125	130	130	79	
5	3.1KHz Temporal 3	High	35	38	87	89	91	115	155	155	165	165	86	
6	3.1KHz Temporal 3	Low	35	38	87	89	91	115	128	130	135	135	80	
7	3.1KHz Non-Temporal	High	40	42	87	89	91	115	125	125	135	135	86	
8	3.1KHz Non-Temporal	Low	35	38	87	89	91	115	120	120	130	130	80	

L-Series with LED Dimensions: Wall-Mounted Equipment

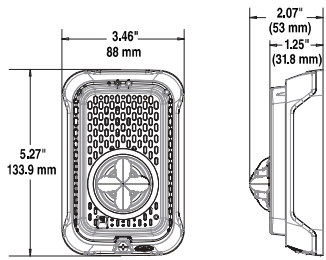

A0617-00

**Compact Strobe, Horn Strobe
for Wall**

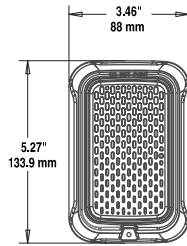

A0547-00

Compact Horn

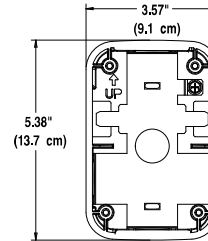
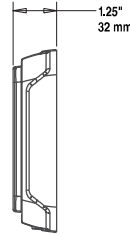

A0557-00

**Compact Surface Mount Back Box
for Walls (SBBGRL, SBBGWL)**

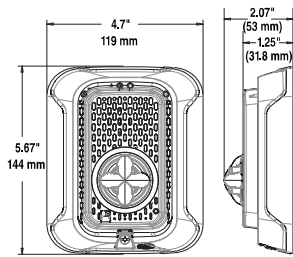
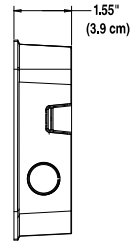

A0613-00

**Strobes, Horn Strobes
for Walls**

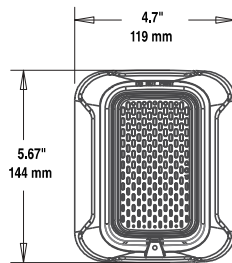

A0549-00

Horn

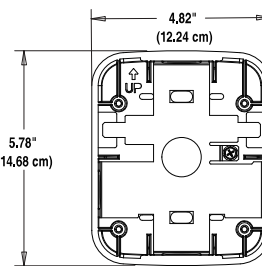
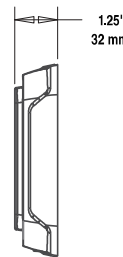

A0554-01

**Surface Mount Back Box
for Walls (SBBRL/SBBWL)**

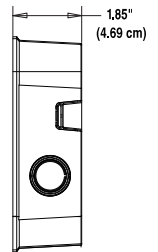

L-Series with LED Dimensions: Ceiling-Mounted Equipment

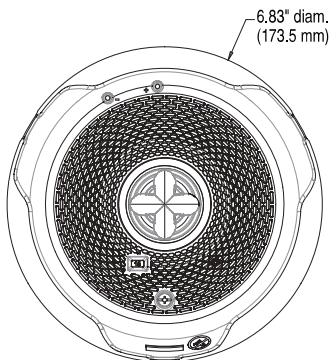

A0608-00

**Strobes and Horn Strobes
for Ceilings**

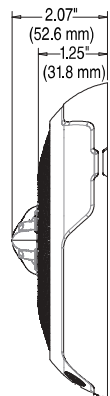

6.92" diam.
(175.77 mm)

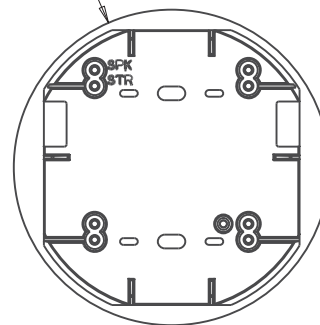

A0546-00

**Surface Mount Back Box
for Ceilings (SBBCL, SBCWL)**

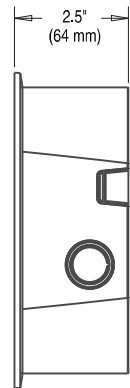

L-Series with LED: Ordering Information

Model	Description
L-Series with LED Horn Strobes	
P2RLED	2-Wire, Horn Strobe, Wall, Red
P2RLED-B	2-Wire, Horn Strobe, Wall, Red, Bilingual
P2WLED	2-Wire, Horn Strobe, Wall, White
P2WLED-B	2-Wire, Horn Strobe, Wall, White, Bilingual
P2GRLED	2-Wire, Compact Horn Strobe, Wall, Red
P2GRLED-B	2-Wire, Compact Horn Strobe, Wall, Red, Bilingual
P2GWLED	2-Wire, Compact Horn Strobe, Wall, White
P2GWLED-B	2-Wire, Compact Horn Strobe, Wall, White, Bilingual
P2RLED-P	2-Wire, Horn Strobe, Wall, Red, Plain
P2WLED-P	2-Wire, Horn Strobe, Wall, White, Plain
P2RLED-SP	2-Wire, Horn Strobe, Wall, Red, FUEGO
P2WLED-SP	2-Wire, Horn Strobe, Wall, White, FUEGO
PC2RLED	2-Wire, Horn Strobe, Ceiling, Red
PC2RLED-B	2-Wire, Horn Strobe, Ceiling, Red, Bilingual
PC2WLED	2-Wire, Horn Strobe, Ceiling, White
PC2WLED-B	2-Wire, Horn Strobe, Ceiling, White, Bilingual
L-Series with LED Strobes	
SRLED	Strobe, Wall, Red
SRLED-B	Strobe, Wall, Red, Bilingual
SWLED	Strobe, Wall, White
SWLED-B	Strobe, Wall, White, Bilingual
SGRLED	Strobe, Compact, Wall, Red
SGRLED-B	Strobe, Compact, Wall, Red, Bilingual
SGWLED	Strobe, Compact, Wall, White
SGWLED-B	Strobe, Compact, Wall, White, Bilingual
SRLED-P	Strobe, Wall, Red, Plain
SWLED-P	Strobe, Wall, White, Plain
SRLED-SP	Strobe, Wall, Red, FUEGO
SWLED-CLR-ALERT	Strobe, Wall, White, ALERT
SWLED-ALERT	Strobe, Wall, White, ALERT, Amber Lens
SCRLED	Strobe, Ceiling, Red
SCRLED-B	Strobe, Ceiling, Red, Bilingual
SCRLED-P	Strobe, Ceiling, White, Plain
SCWLED	Strobe, Ceiling, White
SCWLED-B	Strobe, Ceiling, White, Bilingual
SCWLED-P	Strobe, Ceiling, White, Plain
SCWLED-CLR-ALERT	Strobe, Ceiling, White, ALERT
L-Series Horns	
HRL*	Horn, Red
HRLA*	Horn, Red, Plain, ULC
HWL*	Horn, White
HWLA*	Horn, White, Plain, ULC
HGRL*	Compact Horn, Red
HGRLA*	Compact Horn, Red, Plain, ULC
HGWL*	Compact Horn, White
HGWLA*	Compact Horn, White, Plain, ULC

Model	Description
LED Lenses	
LENS-A3	Lens LED Amber Wall/Ceiling
LENS-B3	Lens LED Blue Wall/Ceiling
LENS-G3	Lens LED Green Wall/Ceiling
LENS-R3	Lens LED Red Wall/Ceiling
Accessories	
TR-2	Universal Wall Trim Ring Red
TR-2W	Universal Wall Trim Ring White
SBBRL	Wall Surface Mount Back Box, Red
SBBWL	Wall Surface Mount Back Box, White
SBBGRL	Compact Wall Surface Mount Back Box, Red
SBBGWL	Compact Wall Surface Mount Back Box, White
TRC-2	Universal Ceiling Trim Ring, Red
TRC-2W	Universal Ceiling Trim Ring, White
SBBCRL	Ceiling Surface Mount Back Box, Red
SBBCWL	Ceiling Surface Mount Back Box, White
Bezels†	
BZR	Wall Red Bezel Kit
BZW	Wall White Bezel Kit
BZGR	Compact Wall Red Bezel Kit
BZGW	Compact Wall White Bezel Kit
BZRC	Horn Strobe Ceiling Red Bezel Kit
BZWC	Horn Strobe Ceiling White Bezel Kit

Notes for L-Series With LED Horn Strobes and Strobes:

All -P models have a plain housing (no "FIRE" marking on cover).
 All -SP models have "FUEGO" marking on cover.
 All -ALERT models have "ALERT" marking on cover.
 All -B models have "FIRE/FEU" marking on cover for use in Canadian applications.
 Amber lenses are not for use in Canadian applications

Notes for L-Series Horns:

*Horn-only models are listed for wall or ceiling use.

Notes for Bezels:

†Each bezel pack ships in a package of 5.
 Add one of the following extensions for print/language options: -F (FIRE), -AL (ALERT), -EV (EVAC), -AG (AGENT), -P (Plain), -FR (FEU), -PG (FOGO), -SP (FUEGO), -SPE (FUEGO/FIRE).

3825 Ohio Avenue • St. Charles, IL 60174 USA
 Phone: 800-SENSOR2 • Fax: 630-377-6495
www.systemsensor.com

System Sensor® is a registered trademark
 of Honeywell International, Inc.



3333 Unity Drive, Mississauga, ON L5L 3S6 Canada
 Phone: 800-SENSOR2 • Fax: 905-812-0771
www.systemsensor.ca

©2023 System Sensor.
 Product specifications subject to change without notice. Visit www.systemsensor.com
 for current product information, including the latest version of this data sheet.
 AVDS916-01 • 10/03/2023

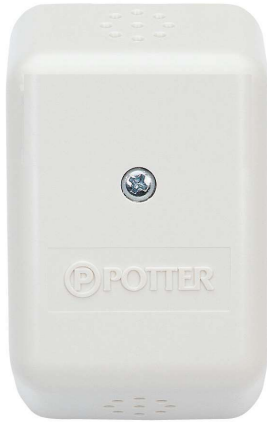

- Listings:** UL, cUL Listed
- Enclosure:** White ABS
- Dimensions:** 2 1/16"W x 3 7/16"L x 1 1/4"H
(5,2cm W x 8,7cm L x 3,2cm H)
- Sensor:** Epoxy sealed stainless steel case, bi-metallic operating mechanism.
- Contacts:** Silver clad, available normally open or normally closed
- Electrical Rating:** 1 Amp at 24VDC
- Temperature Setting:** 40° ±5°F (4,5° ±3°C)
- Terminals:** Screw Terminals
- Mounting:** Wall Mount, Surface

RTS-O Stock No. 1010108
RTS-C Stock No. 1010109

Application

The RTS Series complies with the requirements of NFPA 13 and 72 for a room temperature switch to operate at 40°F to protect a dry pipe valve from freezing. The RTS can also be used for other temperature detection applications.

Operation

The normally open detector, RTS-O, will close the contact when the temperature drops below 40°F (4,5°C). The normally closed detector, RTS-C, will open the contact when the temperature drops below 40°F (4,5°C). The detector will automatically reset to the normal state when the temperature rises above 40°F (4,5°C).

The RTS Series Room Temperature Sensors are precision engineered, designed and manufactured for commercial or residential use.

Description

Each unit consists of a bi-metal operating mechanism, featuring hermetically sealed precious metal contacts, N.O. or N.C., which automatically reset for repetitive operation, eliminating the need for sensing element replacement.

Small compact design, highly resistant to vibration and corrosion. Easily installed using the enclosed hardware or adhesive mounting pad.

Screw terminals permit easy installation in single or multiple detector circuits.

Features:

- Easily installed
- Completely sealed sensor, moisture and vapor resistant
- Highly resistant to vibration and corrosion
- Highly sensitive to temperature changes
- No sensitivity loss due to aging
- Repetitive operation without the need to replace sensing elements
- Small compact design
- Precision and quality at low cost

Customer:	
Project:	
Engineer:	
Architect:	
PRO or PO:	
QTY:	



BY SPACE AGE ELECTRONICS

FAD/SRD ACE-11

Document Boxes

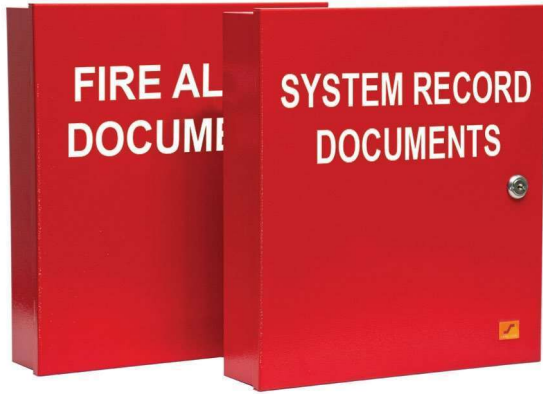

Store important system documents in a secure location with a cabinet built specifically to meet the requirements of NFPA72 7.7.2.1, NFPA72 7.7.2.3, NFPA72 7.7.2.5, and NFPA72 23.2.2.1.

Select models include our innovative 8GB flash drive slide tab that allows the user to select a USB-C or Micro USB connector to access records electronically per NFPA72 7.5.6.7.1 and NFPA72 7.5.6.7.2.

SPECIFICATIONS

The FAD and SRD Documents Box shall be UL Listed, constructed of 18 gauge cold rolled steel. It shall have a powder coat finish. The cover shall be permanently screened with 1" high lettering "FIRE ALARM DOCUMENTS" or "SYSTEM RECORD DOCUMENTS" with white indelible ink. The access door shall be locked with a 3/4" barrel lock and there will be a liftaway hinge. Models with digital storage will have a minimum of 8 gigabyte digital flash memory drive with a slide tab that allows user to select USB-C or Micro USB connector for uploading and downloading information. The enclosure will supply 4 mounting holes. Inside will accommodate standard 8 1/2" x 11" manuals, three-ring binders, and document records. The enclosure shall also provide 2 key ring holders with a location to mount standard business cards for key contact personnel.

FEATURES

- 18 gauge cold rolled steel construction with red or black powder coat and white lettering
- Dimensions are 12" wide x 13" tall and 3" deep
- Liftaway hinge
- Removable document holder with two key ring hooks and business card bracket
- Slide tab allows user to select USB-C or Micro USB connector to download from 8GB digital flash memory



CUSTOM BRANDING AVAILABLE



DIMENSIONS

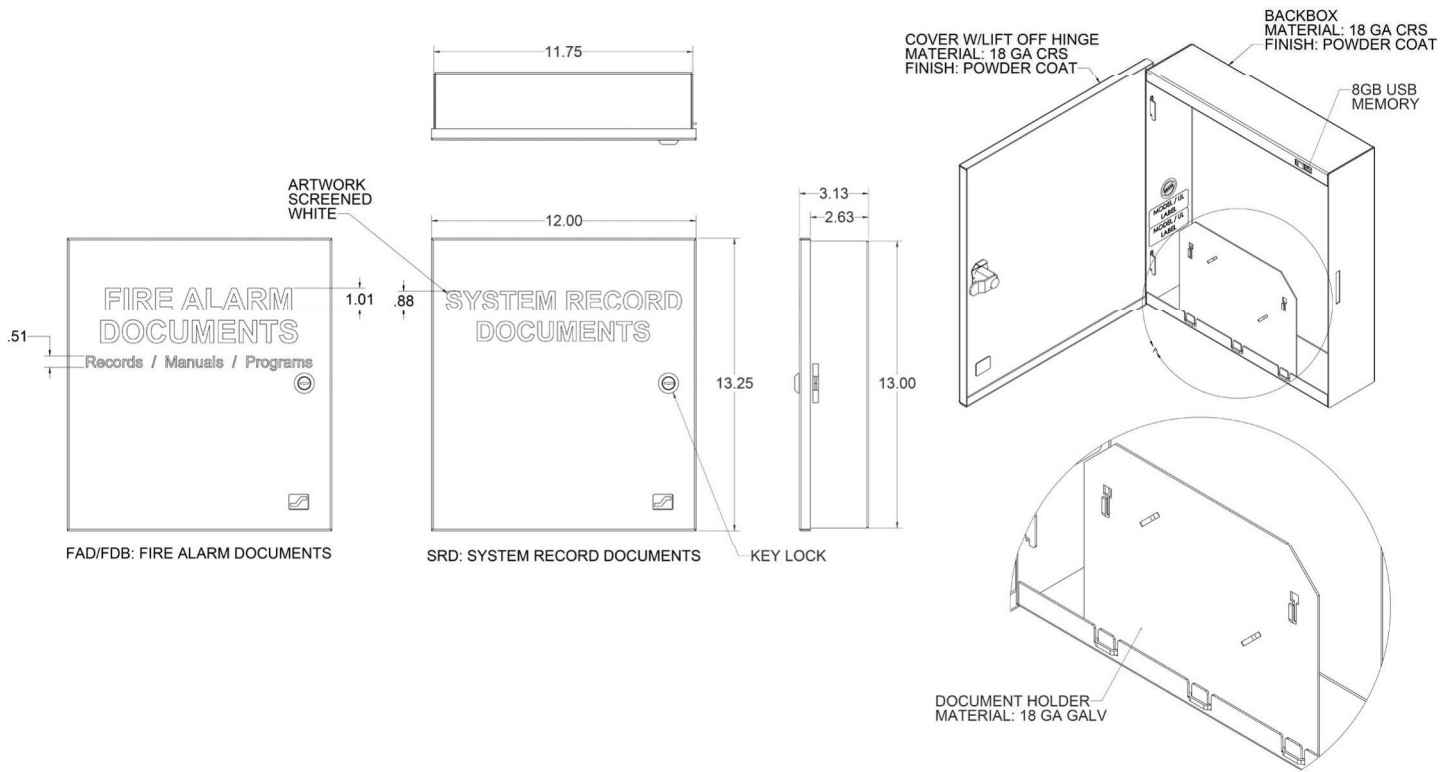

ORDERING INFORMATION

P/N#	Cover Text	Color	Custom Screening	USB Storage
SSU00672	Fire Alarm Documents	Red	No	No
SSU00673	Fire Alarm Documents	Red	Yes	No
SSU00685	Fire Alarm Documents	Red	No	Yes
SSU00686	Fire Alarm Documents	Red	Yes	Yes
SSU00689	System Record Documents	Red	No	Yes
SSU00690	System Record Documents	Red	Yes	Yes
SSU01672C	Fire Alarm Documents	Black	Yes	No
SSU01689	System Record Documents	Black	No	Yes
SSU01690	System Record Documents	Black	Yes	Yes



Product Data Sheet

IM Series: IM-12120NB (UT-12120)

12 Volt, 12.0Amp. Hour

Specifications

Rated Voltage	12V	
Nominal Capacity	12.0Ah	(C ₂₀ , 1.75V/cell, 20hr)
Dimensions	Length	5.95 inches (151mm)
	Width	3.86 inches (98mm)
	Container Height	3.74 inches (95mm)
	Total Height	4.21 inches (107mm)
Approx Weight	8.53lbs. (3.87kg)	
Terminal	NB 3-A	
Container Material	ABS	
Rated Capacity (25°C)	12.0Ah	(20hr, 0.600A, 1.75V/cell)
	11.3Ah	(10hr, 1.13A, 1.75V/cell)
	10.4Ah	(5hr, 2.07A, 1.75V/cell)
	9.18Ah	(3hr, 3.06A, 1.75V/cell)
	8.10Ah	(1hr, 8.10A, 1.60V/cell)
Max. Discharge Current	180A (5s)	
Internal Resistance (25°C)	Approx 19.0mΩ	
Operating Temp. Range	Discharge	5 ~ 122°F (-15 ~ 50°C)
	Charge	-4 ~ 104°F (-20 ~ 40°C)
	Storage	5 ~ 104°F (-15 ~ 40°C)
Nominal Operating Temp. Range	77±5°F (25±3°C)	
Standby/Float Use	Initial Charging Current less than 3.6A. Voltage 13.5V~13.8V at 77°F (25°C) Temp. Coefficient -10mV/°F	
Temperature Effect on Capacity	104°F (40°C)	103%
	77°F (25°C)	100%
	32°F (0°C)	86%

IM series batteries may be stored for up to 6 months at 77°F (25°C) and then a freshening charge is required. For higher temperatures- time interval will be shorter.

Self Discharge



Layout

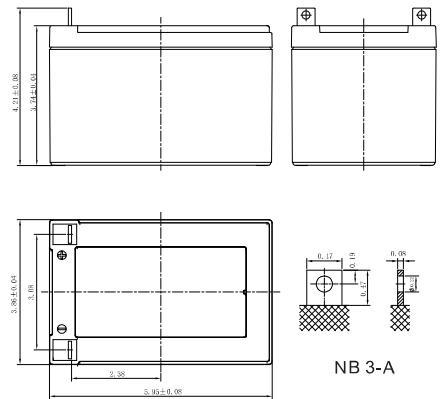

Constant Current Discharge (Amperes) at 77°F (25°C)

F.V/Time	5min	10min	15min	20min	30min	45min	1h	1.5h	2h	3h	4h	5h	6h	8h	10h	20h
1.85V/cell	40.1	27.3	20.7	16.9	12.4	9.00	7.30	5.30	4.14	2.96	2.36	2.01	1.72	1.36	1.11	0.587
1.80V/cell	43.1	28.9	21.8	17.5	12.8	9.20	7.50	5.40	4.22	3.01	2.40	2.04	1.75	1.38	1.12	0.593
1.75V/cell	45.5	30.1	22.5	18.0	13.1	9.40	7.60	5.50	4.29	3.06	2.43	2.07	1.77	1.39	1.13	0.600
1.70V/cell	47.6	31.3	23.2	18.6	13.5	9.70	7.80	5.60	4.36	3.11	2.46	2.09	1.79	1.41	1.15	0.605
1.67V/cell	49.2	32.2	23.8	18.9	13.7	9.80	7.90	5.70	4.41	3.14	2.49	2.11	1.81	1.42	1.15	0.610
1.60V/cell	52.2	33.5	24.6	19.5	14.1	10.1	8.10	5.80	4.50	3.19	2.53	2.15	1.83	1.44	1.17	0.616

CO.V - Cutoff Voltage/cell. The battery is fully charged & being discharged to COV.

Constant Power Discharge (Watts/cell) at 77°F (25°C)

F.V/Time	5min	10min	15min	20min	30min	45min	1h	1.5h	2h	3h	4h	5h	6h	8h	10h	20h
1.85V/cell	75.9	51.9	39.7	32.5	24.0	17.5	14.2	10.4	8.11	5.83	4.65	3.97	3.41	2.69	2.20	1.17
1.80V/cell	80.8	54.7	41.4	33.6	24.6	17.9	14.5	10.6	8.24	5.91	4.71	4.02	3.45	2.73	2.23	1.19
1.75V/cell	84.2	56.5	42.5	34.4	25.2	18.2	14.8	10.7	8.37	5.99	4.77	4.07	3.49	2.75	2.25	1.20
1.70V/cell	87.3	58.3	43.7	35.2	25.7	18.5	15.0	10.9	8.47	6.07	4.83	4.12	3.53	2.78	2.27	1.21
1.67V/cell	89.6	59.6	44.6	35.8	26.1	18.8	15.2	11.0	8.55	6.12	4.87	4.15	3.56	2.80	2.29	1.22
1.60V/cell	93.3	61.4	45.8	36.7	26.6	19.1	15.5	11.2	8.69	6.21	4.94	4.20	3.60	2.84	2.32	1.23

CO.V - Cutoff Voltage/cell. The battery is fully charged & being discharged to COV.





Product Data Sheet

IM Series: IM-12120NB (UT-12120)

12 Volt, 12.0Amp. Hour

Applications

- All purpose
- Uninterruptable Power Supply (UPS)
- Electric Power System (EPS)
- Emergency backup power supply
- Alarm and security system
- Communication power supply
- DC power supply
- Auto control system

General Features

- 5 years design life (77°F)
- Special exhaust structure and sealing technology, safe and reliable, flexible installation, convenient maintenance
- High purity PbCaSn raw material alloy is used for plate grids, assuring less gassing and low self-discharging rate
- High quality AGM separator extends cycle life and prevents micro short circuit

Standards

- Compliance with IEC 60896 standards, EU Battery Directive
- UL, CE Certified
- Manufactured in IATF16949, ISO45001, ISO 9001 and ISO 14001 certified production facilities



Discharge Characteristics

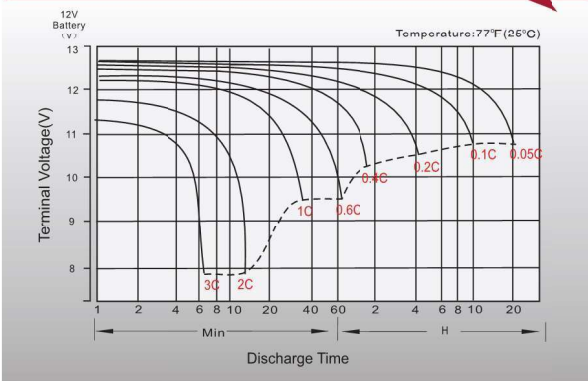

Standby/Float Charging Characteristics

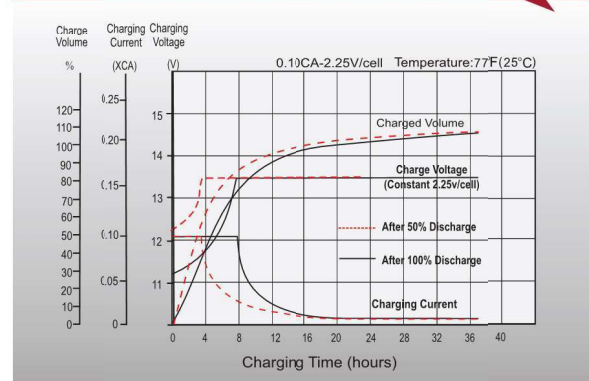

Temperature Effects on Battery Capacity

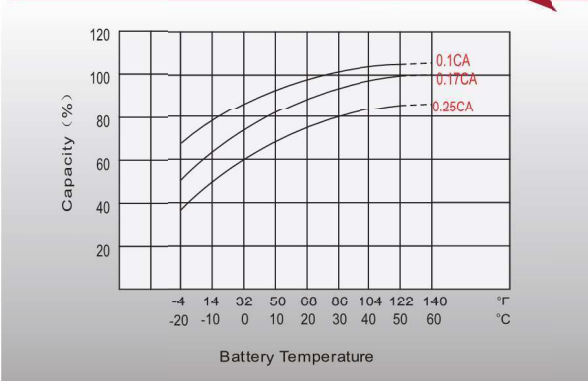

Temperature Effects on Long-Term Float Life

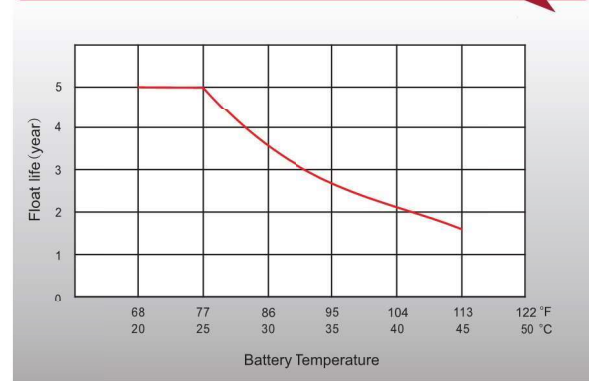

Sales Offices

Sales: 1.800.233.6261
 Website: www.adiglobaldistribution.us
www.adiglobaldistribution.ca



Product Data Sheet

IM Series: IM-1272F2 (UT-1272F2)

12 Volt, 7.0 Amp. Hour

Specifications

Rated Voltage	12V	
Nominal Capacity	7.0Ah	(C ₂₀ , 1.75V/cell, 20hrs)
Dimensions	Length	5.95 inches (151 mm)
	Width	2.56 inches (65 mm)
	Container Height	3.68 inches (93.5 mm)
	Total Height	3.92 inches (99.5 mm)
Approx Weight	4.34 lbs (1.97 Kg)	
Terminal	F2	
Container Material	ABS	
Rated Capacity (25°C)	7.00 Ah	(20hr, 0.350A, 1.75V/cell)
	6.53 Ah	(10hr, 0.653A, 1.75V/cell)
	5.85 Ah	(5hr, 1.19A, 1.75V/cell)
	5.30 Ah	(3hr, 1.77A, 1.75V/cell)
	4.27 Ah	(1hr, 4.27A, 1.60V/cell)
Max. Discharge Current	105A (5s)	
Internal Resistance (25°C)	Approx 33mΩ	
Operating Temp. Range	Discharge	5 ~ 122°F (-15 ~ 50°C)
	Charge	-4 ~ 104°F (-20 ~ 40°C)
	Storage	5 ~ 104°F (-15 ~ 40°C)
Nominal Operating Temp. Range	77±5°F (25±3°C)	
Standby/Float Use	Initial Charging Current less than 2.1A. Voltage	
	13.5V~13.8V at 77°F(25°C)Temp. Coefficient -10mV/°F	
Temperature Effect on Capacity	104°F (40°C)	103%
	77°F (25°C)	100%
	32°F (0°C)	86%
Self Discharge	IM series batteries may be stored for up to 6 months at 77°F(25°C) and then a freshening charge is required. For higher temperatures - time interval will be shorter.	



Layout

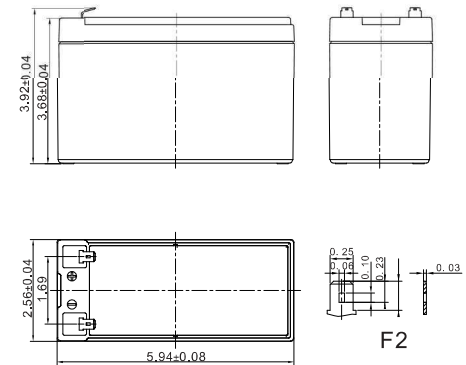

Constant Current Discharge (Amperes) at 77°F(25 °C)

F.V/Time	5min	10min	15min	20min	30min	45min	1h	1.5h	2h	3h	4h	5h	6h	8h	10h	20h
1.85V/cell	17.0	12.5	9.90	8.10	6.12	4.64	3.91	2.90	2.38	1.72	1.36	1.16	0.99	0.780	0.637	0.343
1.80V/cell	18.5	13.2	10.3	8.35	6.28	4.73	3.99	2.95	2.41	1.74	1.38	1.18	1.01	0.790	0.644	0.347
1.75V/cell	19.9	13.8	10.7	8.60	6.43	4.83	4.06	3.00	2.45	1.77	1.40	1.19	1.02	0.800	0.653	0.350
1.70V/cell	21.4	14.4	11.1	8.86	6.57	4.92	4.13	3.05	2.49	1.79	1.42	1.21	1.03	0.809	0.660	0.354
1.67V/cell	22.3	14.8	11.3	9.01	6.67	4.98	4.17	3.08	2.51	1.81	1.43	1.22	1.04	0.816	0.665	0.356
1.60V/cell	24.3	15.7	11.8	9.40	6.87	5.11	4.27	3.14	2.56	1.84	1.46	1.24	1.06	0.829	0.675	0.361

C.O.V - Cutoff Voltage/cell. The battery is fully charged & being discharged to COV

Constant Power Discharge (Watts/cell) at 77°F(25 °C)

F.V/Time	5min	10min	15min	20min	30min	45min	1h	1.5h	2h	3h	4h	5h	6h	8h	10h	20h
1.85V/cell	32.3	23.9	19.1	15.6	11.8	9.01	7.61	5.67	4.65	3.37	2.69	2.29	1.96	1.55	1.27	0.686
1.80V/cell	34.8	25.0	19.7	16.0	12.1	9.15	7.73	5.74	4.71	3.42	2.72	2.32	1.99	1.57	1.28	0.693
1.75V/cell	37.4	26.1	20.3	16.4	12.3	9.30	7.84	5.82	4.77	3.46	2.76	2.35	2.01	1.58	1.29	0.700
1.70V/cell	39.9	27.2	20.9	16.8	12.5	9.40	7.95	5.90	4.84	3.50	2.79	2.37	2.03	1.60	1.31	0.707
1.67V/cell	41.4	27.8	21.3	17.1	12.7	9.50	8.02	5.95	4.87	3.53	2.81	2.39	2.05	1.61	1.32	0.712
1.60V/cell	44.7	29.2	22.1	17.6	13.0	9.70	8.17	6.05	4.95	3.59	2.85	2.43	2.08	1.64	1.34	0.722

C.O.V - Cutoff Voltage/cell. The battery is fully charged & being discharged to COV





Product Data Sheet

IM Series: IM-1272F2 (UT-1272F2)

12 Volt, 7.0 Amp. Hour

Applications

- All purpose
- Uninterruptable Power Supply (UPS)
- Electric Power System (EPS)
- Emergency backup power supply
- Alarm and security system
- Communication power supply
- DC power supply
- Auto control system

General Features

- 5 years design life(77°F)
- Special exhaust structure and sealing technology, safe and reliable, flexible installation, convenient maintenance
- High purity PbCaSn raw material alloy is used for plate grids, assuring less gassing & low self-discharge rate
- High quality AGM separator: extend cycle life and prevent micro short circuit

Standards

- Compliance with IEC 60896 standards, EU Battery Directive
- UL, CE Certified
- Manufactured in IATF 16949, ISO45001, ISO 9001 and ISO 14001 certified production facilities



Discharge Characteristics

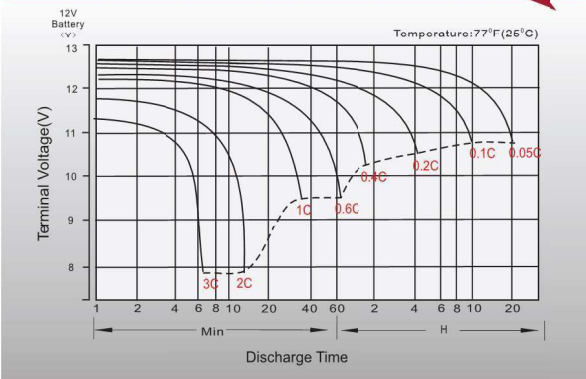

Standby/Float Charging Characteristics

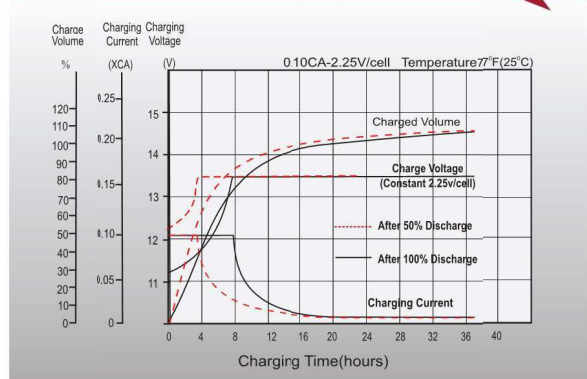

Temperature Effects on Battery Capacity

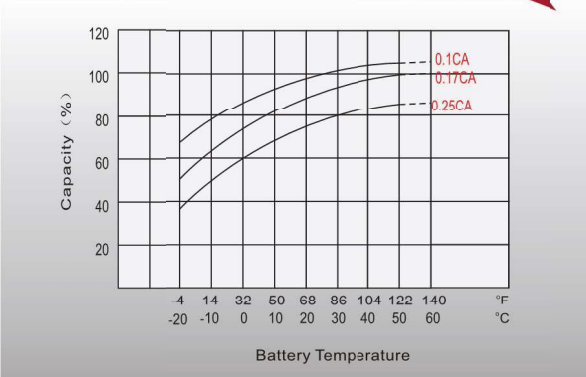

Temperature Effects on Long Term Float Life

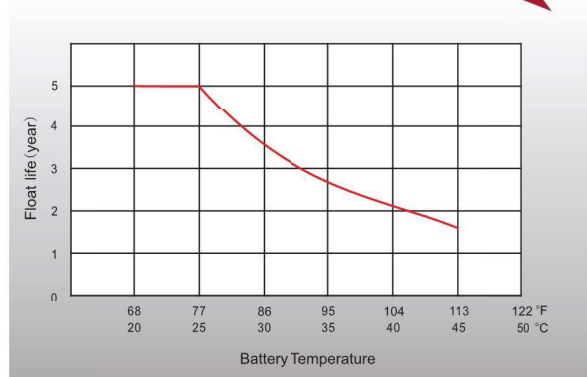

Sales Offices

Sales: 1.800.233.6261
Website: www.adiglobaldistribution.us
www.adiglobaldistribution.ca



PS-12260 12V 26.0 AH @ 20-hr. 12V 24.7 AH @ 10-hr.

Rechargeable Sealed Lead Acid Battery
PS – General Purpose Series

TERMINALS: (mm)

F2: Quick disconnect tabs, 0.250" x 0.032" – Mate with AMP. INC FASTON "250" series

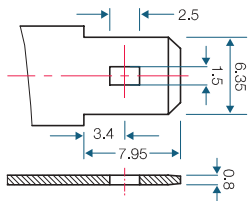

Torque – Not Applicable

NB1: Tin plated brass post with 'Nut & Bolt' fasteners

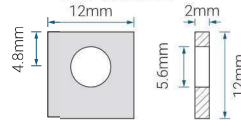

Torque: 2.0~3.0 Nxm

T12: Threaded insert with 5mm stud fastener

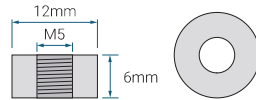

Torque: 2.0~3.0 Nxm

DIMENSIONS: inch (mm)

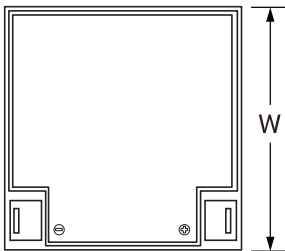

L: 6.56 (167)
W: 6.97 (177)
H: 4.92 (125)
HT: 4.92 (125)

Tolerances are +/- 0.04 in. (+/- 1mm) and +/- 0.08 in. (+/- 2mm) for height dimensions. All data subject to change without notice.

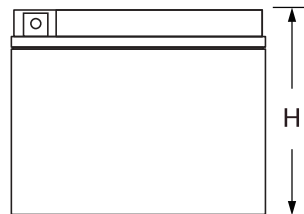
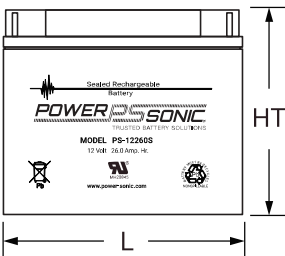

GLOBAL HEADQUARTERS (USA AND INTERNATIONAL EXCLUDING EMEA)

Power-Sonic Corporation
365 Cabela Dr Suite 300,
Reno, Nevada 89523
USA
T: +1 619 661 2020
E: customer-service@power-sonic.com

POWER-SONIC EMEA (EMEA – EUROPE, MIDDLE EAST AND AFRICA)

Smitspol 4, 3861 RS Nijkerk,
The Netherlands
T NL: +31 33 7410 700
T UK: +44 1268 560 686
T FR: +33 344 32 18 17
E: salesEMEA@power-sonic.com

FEATURES

- 5 year design life
- Absorbent Glass Mat (AGM) technology for superior performance
- Valve regulated, maintenance free spill proof construction
- Power/volume ratio yielding excellent energy density
- Rugged vibration and impact resistant ABS case and cover
- Gas recombination technology

APPROVALS

- Approved for transport by air. D.O.T., I.A.T.A., F.A.A. and C.A.B. certified
- U.L. recognized
- ISO9001:2015 – Quality management systems

PERFORMANCE SPECIFICATIONS

Nominal Voltage	12 volts (6 cells)
Nominal Capacity	
20-hr. (1.3A to 10.50 volts)	26.0 AH
10-hr. (2.47A to 10.50 volts)	24.7 AH
5-hr. (4.42A to 10.20 volts)	22.1 AH
1-hr. (15.8A to 9.60 volts)	15.8AH
Approximate Weight	17.60 lbs. (8.0 kg)
Internal Resistance (approx.)	11.0 milliohms
Max Short-Duration Discharge Current (5 Sec.)	390.0 amperes
Shelf Life (% of nominal capacity at 68°F (20°C))	
1 Month	92%
3 Month	90%
6 Month	80%
Operating Temperature Range	
Charge	5°F (-15°C) to 104°F (40°C)
Discharge	5°F (-15°C) to 122°F (50°C)
Case	ABS Plastic
Power Sonic Chargers	PSC-124000-PC PSC-124000A-C

PS-12260 12V 26.0 AH @ 20-hr.
12V 24.7 AH @ 10-hr.

Rechargeable Sealed Lead Acid Battery
PS – General Purpose Series

SHELF LIFE & STORAGE

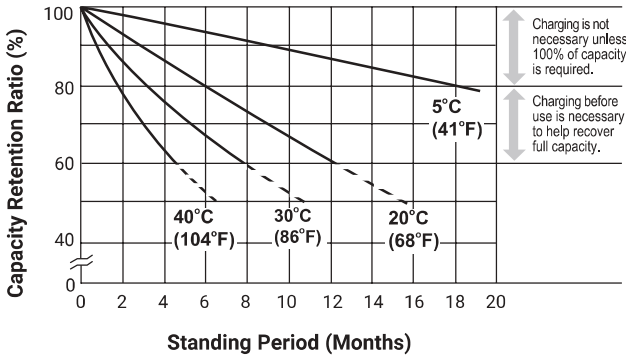

LIFE CHARACTERISTICS IN STAND-BY USE

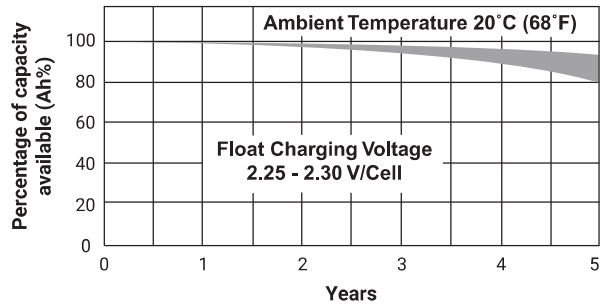

CHARGING

Cycle Applications: Apply constant voltage charge at 2.35v/c – 2.45v/c (14.1 – 14.7v for 12v Monobloc) at 20°C. Initial charging current should be set at less than 0.25C Amps. Switch to float charge to avoid overcharging.

“Float” or “Stand-By” Service: Apply constant voltage charge of 2.25v/c – 2.30v/c (13.5 to 13.8 volts for 12v Monobloc) at 20°C. When held at this voltage, the battery will seek its own current level and maintain itself in a fully charged condition.

Temperature Compensation: Charging Voltage for both Cyclic and Standby applications should be regulated in relation to ambient temperature. As temperature rises charging voltage should be reduced to prevent overcharge and increased as temperature falls to avoid undercharge.

For further charging information including temperature compensation factors, see Power Sonic Technical Manual/ Power Sonic Charger specifications.

APPLICATIONS

- General purpose
- Medical
- Emergency lighting
- Fire and security

GLOBAL HEADQUARTERS
(USA AND INTERNATIONAL EXCLUDING EMEA)

Power-Sonic Corporation
365 Cabela Dr Suite 300,
Reno, Nevada 89523
USA
T: +1 619 661 2020
E: customer-service@power-sonic.com

POWER-SONIC EMEA
(EMEA – EUROPE, MIDDLE EAST AND AFRICA)

Smitspol 4, 3861 RS Nijkerk,
The Netherlands
T NL: +31 33 7410 700
T UK: +44 1268 560 686
T FR: +33 344 32 18 17
E: salesEMEA@power-sonic.com

CHARGERS

Power Sonic offers a wide range of chargers suitable for batteries with a variety of capacities.

Please refer to our website for more information on our switch mode and transformer type chargers.

Please contact our technical department for advice if you have difficulty in locating a suitable charger.

FURTHER INFORMATION

Please refer to our website www.power-sonic.com for a complete range of useful downloads, such as product catalogs, material safety data sheets (MSDS), ISO certification, etc.





Submittal Device List

Manufacturer	Part Number	Description	✓
POTTER	PFC-4410G3	RELEASING PANEL	
POTTER	3001000	ABORT SWITCH	
POTTER	RMS-2T-WP-LP	DUAL ACTION MANUAL RELEASE	
SYSTEM SENSOR	2W-B	SMOKE DETECTOR	

Features

- Multi-Hazard Capability
- Seven Programmable Class B Initiating Circuits
- Four Class B Output Circuits
- Programmable Cross Zoning including AND/OR capability
- Supervised Microprocessor
- 4 x 20 LCD display with 37 system status LEDs
- Integrated Battery Meter
- On Board Menu Driven Programming Controls
- Releasing Circuits Protected From False Activation
- 4000 Event History Buffer
- Walktest with Automatic Time-out
- Alarm, Trouble, Supervisory, and Waterflow/Discharge confirmation relays
- Up to 35 standard programs in panel memory
- Password protection
- Suitable for agent and/or water-based extinguishing
- Programmable pre-discharge and soak timers
- Ethernet port for programming and network connectivity
- Five Abort modes



Description

The Potter Model PFC-4410G3 is a conventional multi-hazard releasing control panel well suited for a number of applications. The PFC-4410G3 is listed for use with pre-action and deluge sprinkler suppression systems and agent-based fire suppression systems.

The panel utilizes a microprocessor-based system that has up to 35 standard programs in panel memory, which covers a majority of installations. The simple to follow Menu Structure programs the entire system in a matter of seconds. In addition to the Standard Programs, the panel allows custom programming to accommodate any installation. Programming is accomplished either through the menu driven on-board controls or from a laptop via the Ethernet connection.

The PFC-4410G3 is housed in a red durable steel cabinet with removable door and key lock. An optional flush mount trim ring is available. The cabinet contains knockouts on the side, back and top of the cabinet to ease installation. In addition, the cabinet will house up to two (2) twelve (12) amp-hour batteries that will provide in excess of 90 hours of standby power.

Technical Specifications

Battery Capacity	Up to two (2) 12Ah batteries
Battery	<ul style="list-style-type: none"> • 3 Amps power for NACs, AUX, and P-Link • 3 Amps per NAC, regulated • Battery Charger range 8-55 Ah • Battery Charger voltage 27.3 VDC • P-Link maximum current of 1 Amp • AUX maximum current of 1 Amp
Dimensions	18 1/4" x 14 1/2" x 4 3/4"
Enclosure	18 AWG cold rolled steel, locking removable door, full dead front, multiple 1/2" and 3/4" knockouts
Environmental	Indoor use only, 32-120 F (0-49C) 95% relative humidity
Power Requirement	120-240 VAC 50/60 Hz
Standards/Service	UL 864-11, ULC S527-19, NFPA 12, 12A, 13, 15, 16, 17, 17A, 72, 750, 2001, FM, CSFM, CE, RoHS III, FDNY

User Interface

The panel has a 4 x 20 LCD display to provide system status information and aid in programming. The full function keypad includes navigation arrows to allow manipulation of the on-board menu and for scrolling through multiple events. In addition to the LCD, the panel also has alarm, trouble and supervisory LEDs per zone, alarm and trouble LEDs per output, and the following system status LEDs:

POWER
POWER TROUBLE
EARTH FAULT
ALARM
TROUBLE
SUPERVISORY
SIGNAL SILENCED
DISCHARGE/PREDISCHARGE

P-Link

The PFC-4410G3 contains the Potter proprietary communication protocol through RS-485 connections to expansion/field devices. The devices may be any of the following:

RA-4410G3 - Remote annunciator consisting of the same user interface and controls as the main panel.

IDC-6 - Six initiating zone expansion module.

LED-4410G3 - 16 LED annunciator with common indicators in a lockable metal enclosure.

PSN-1000 - 10 amp intelligent remote power supply.

RLY-5 - Relay module, provides 5 form C relay contacts rated 1A at 24 VDC/125 VAC

CA-4064 - Class A module for NAC and P-Link

Ethernet Connection

The PFC-4410G3 is shipped standard with an Ethernet connection. This connection can be used as a programming port and may be connected to a building Wide Area Network (WAN) or Local Area Network (LAN). Once connected to the Internet, the panel may be selectively programmed to email system alarm, trouble or supervisory conditions, test or event history. In addition, reminders may be set to send an email for service, testing or other conditions

NOTICE

Some electronic components used in releasing control panels have a typical service life of approximately 10 years. The service life may be reduced by local environmental conditions.

Ordering Information

Model	Description	Stock No.
PFC-4410G3	7 Zone Releasing Control Panel (Red Cabinet)	3006735
PFC-4410G3-PCA	Replacement Motherboard	3006739
PFC-TR	Bezel for Semi-Flush Mounting (Red)	5090155
BT-80	Battery, 12V 8AH for 24 hour standby (2 Req'd)	5130084
BT-120	Battery, 12V 12AH for 24 hour standby (2 Req'd)	5130090
BT-180	Battery, 12V, 18AH for 90 hour standby (2 Req'd)	5130086
CA2Z	2 Zone Class A Initiating Circuit Module	3006013
ARM-1	Auxiliary Relay Module	3004726
RLY-5	5 form C relay module	3992667
RA-4410G3	Remote Annunciator	3006740
IDC-6	6 Initiating Zone Expansion Module	3992362
CA-4064	Class A NAC and P-Link Module	3992361
RCDS-PM1	Panel Mount Release Circuit Disconnect, Single Switch	3001013
RCDS-PM2	Panel Mount Release Circuit Disconnect, Double Switch	3001014
LED-4410G3	16 LED Annunciator	3006743
PSN-1000	10 Amp Intelligent Power Supply	3992662

Dimensions

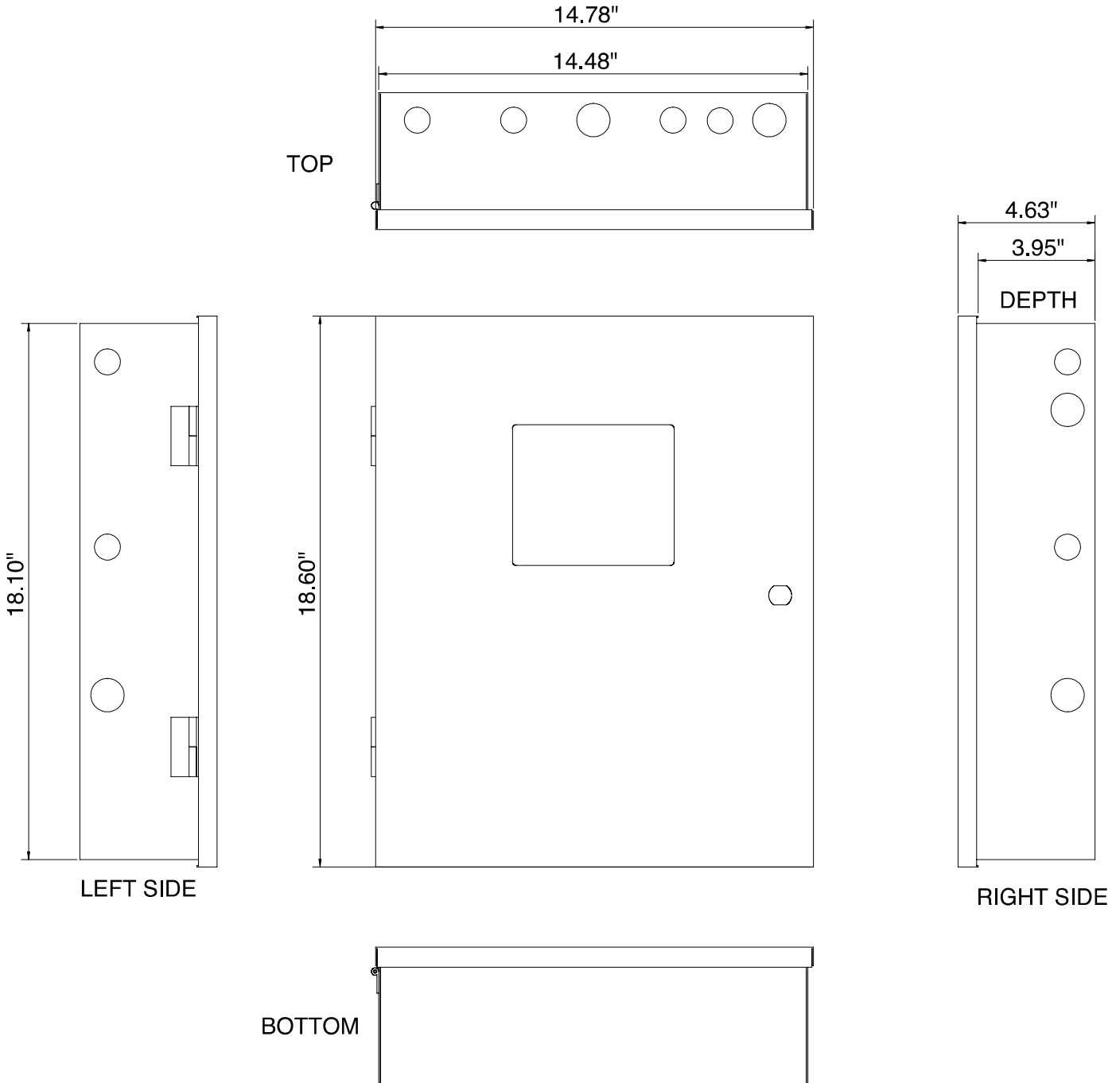



UL and cUL Listed, FM Approved

Dimensions:

4-1/2" W x 4-1/2" H x 2" D (Approximate)

Contact Rating:

One N.O. momentary contact rated.
2.5 Amps @ 24 VDC (5 mA minimum)

Environmental Specifications:

Indoor use only

Stock number: 3001000 - RED BUTTON
3001004 - BLUE BUTTON

Description

The Potter Abort Switch is designed to be wired to the abort terminals of the Potter PFC-4410-RC, PFC-4410A-RC and PFC-4410RC (9th Edition) releasing panels. The device consists of a stainless steel faceplate and a modular switch assembly. It is designed to mount on a standard double gang electrical enclosure.

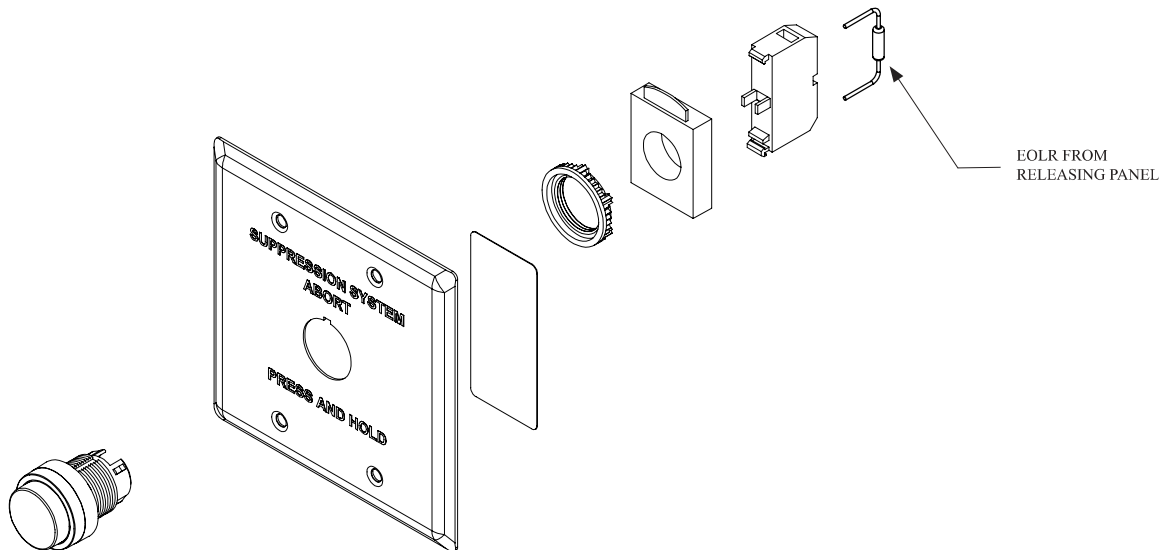



- UL and cUL Listed, FM Approved, CSFM Listed, MEA Approved, ADA Compliant
- Single or Dual Action
- Terminal connectors
- 10 Amp Snap Action Switch
- Gold plated SPST contacts
- Optional auxiliary contacts
- Mounts on standard single gangbox
- Surface backboxes available
- High-gloss red enamel finish
- Glass break rod
- Made in the U.S.A.

Description

The Potter Pull Station Series offers a complete line of die-cast pull stations for a variety of applications focusing mainly on fire alarm systems. The pull stations are available in single or dual action models. All of the pull stations have a 10-amp snap action switch and a dedicated terminal block for the ease of wire connections. All of the metal is completely coated to inhibit corrosion and provide for a uniform and quality finish.

The standard models have a hex key reset, however a key reset is also available. The models are available with shallow and deep surface mount back boxes and as a weatherproof version.

Operation

The Potter single action series of pull stations operate by pulling the white operating handle straight down and the handle will lock into place. The dual action stations require the lifting of the front cover and then pulling the white operating handle straight down. The stations are reset by opening the front and placing the handle in the normal position.

Engineering Specifications

The contractor shall furnish and install the Potter series of pull stations as indicated. The pull station shall be die cast construction with a "T" type pull handle that is ADA compliant. Single action pull stations shall be a P32-1T. Dual action pull stations shall be the Potter P32-1T-LP. Any manual pull station installed in an outdoor or wet location shall be a RMS-1T-WP weather proof unit. The contact shall be a single pole, single throw switch rated at 1 amp 30V DC/125V AC. The device shall have a terminal block for ease of wiring. Once activated, the pull station shall be reset by opening the front cover. Opening of the cover in a normal state shall initiate an alarm.

Specifications

Switch Rating: 1 Amp @ 30 VDC

10 Amps @ 125 VAC

Pull Station Dimensions: 4-3/4" H x 3-1/4" W x 7/8" D

Color: Red with raised white letters, white pull bar with raised red letters

For special application manual stations see bulletin #8910014.

For explosion proof manual stations see bulletin #8880014.

Ordering Information

Type	Model Number	Stock Number	Contact Type
Single Action	P32-1T	1000447	SPST
	RMS-2T	1000477	DPST
	RMS-6T	1000478	DPDT
	RMS-1T-KL	1000451	SPST
	RMS-1T-KO	1000450	SPST, key operated, no pull
Weather Proof	RMS-1T-WP	1000401	SPST
Dual Action	P32-1T-LP	1000476	
Weather Proof Dual Action	RMS-1T-WP-LP	1000403	
Accessories			Notes
Dual Action	RMS-LP	1000480	Converts single action to dual action
Back Box	P32-BB	1000444	Surface mount back box
Back Box	P32-DBB	1000445	Deep surface mount back box
Glass Rods	RMS-GB	1000470	Replacement glass rods (10 per pkg)



Photoelectric Smoke Detectors

System Sensor *i*³ series smoke detectors represent significant advancement in conventional detection. The *i*³ family is founded on three principles: installation ease, intelligence, and instant inspection.



Features

- Plug-in detector line, mounting base included
- Large wire entry port
- In-line terminals with SEMS screws
- Mounts to octagonal and single-gang back boxes, 4-square back boxes, or direct to ceiling
- Stop-Drop 'N Lock attachment to base
- Removable detector cover and chamber
- Built-in remote maintenance signaling
- Drift compensation and smoothing algorithms
- Simplified sensitivity measurement
- Wide-angle, dual-color LED indication
- Loop testing via EZ Walk feature
- Built-in test switch

Installation ease. The *i*³ line redefines installation ease with its plug-in design. This allows an installer to pre-wire bases (included with heads). The large wire entry port and in-line terminals provide ample room for neatly routing the wiring inside the base. The base accommodates a variety of back box mounting methods as well as direct mounting with drywall anchors. To complete the installation, *i*³ heads plug into the base with a simple Stop-Drop 'N Lock™ action.

Intelligence. *i*³ detectors offer a number of intelligent features to simplify testing and maintenance. Drift compensation and smoothing algorithms are standard with the *i*³ line to minimize nuisance alarms. 2-wire *i*³ detectors can generate a remote LED-indicated maintenance signal when connected to the 2W-MOD2 loop test/maintenance module or a panel equipped with the *i*³ protocol. The SENS-RDR, a wireless device, displays the sensitivity of *i*³ detectors in terms of percent-per-foot obscuration.

Instant inspection. The *i*³ series provides wide-angle red and green LED indicators for instant inspection of the detector's condition: normal standby, out-of-sensitivity, alarm, or freeze trouble. When connected to the 2W-MOD2 loop test/maintenance module or a panel with the *i*³ protocol, the EZ Walk loop test feature is available on 2-wire *i*³ detectors. This feature verifies the initiating loop wiring by providing LED status indication at each detector.

Agency Listings



S911



3011446



7272-1653:152



290-01-E



2093



3180932

Smoke Detector Specifications

Architectural/Engineering Specifications

Smoke detector shall be a System Sensor i³ Series model number _____, listed to Underwriters Laboratories UL 268 for Fire Protection Signaling Systems. The detector shall be a photoelectric type (Model 2W-B, 4W-B) or a combination photoelectric/thermal (Model 2WT-B, 4WT-B) with thermal sensor rated at 135°F (57.2°C). The detector shall include a mounting base for mounting to 3½-inch and 4-inch octagonal, single-gang, and 4-inch square back boxes with a plaster ring, or direct mount to the ceiling using drywall anchors. Wiring connections shall be made by means of SEMS screws. The detector shall allow pre-wiring of the base and the head shall be a plug-in type. The detector shall have a nominal sensitivity of 2.5 percent-per-foot nominal as measured in the UL smoke box. The detector shall be capable of automatically adjusting its sensitivity by means of drift compensation and smoothing algorithms. The detector shall provide dual-color LED indication that blinks to indicate power up, normal standby, out of sensitivity, alarm, and freeze trouble (Model 2WT-B, 4WT-B) conditions. When used in conjunction with the 2W-MOD2 module, 2-wire models shall include a maintenance signal to indicate the need for maintenance at the alarm control panel and shall provide a loop testing capability to verify the circuit without testing each detector individually.

Electrical Specifications

Operating Voltage	Nominal: 12/24 V non-polarized Minimum: 8.5 V Maximum: 35 V
Maximum Ripple Voltage	30% peak to peak of applied voltage
Standby Current	2-wire: 50 µA maximum average; 4-wire: 50 µA maximum average
Maximum Alarm Current	2-wire: 130 mA limited by control panel; 4-wire: 20 mA @ 12 V, 23 mA @ 24 V
Peak Standby Current	2-wire: 100 µA; 4-wire: n/a
Alarm Contact Ratings	2-wire: n/a; 4-wire: 0.5 A @ 30 V AC/DC

Physical Specifications

Dimensions (including base)	5.3 inches (127 mm) diameter; 2.0 inches (51 mm) height
Weight	6.3 oz (178 g)
Operating Temperature Range	2W-B and 4W-B: 32°F to 120°F (0°C to 49°C); 2WT-B and 4WT-B: 32°F to 100°F (0°C to 37.8°C)
Operating Humidity Range	0 to 95% RH non-condensing
Thermal Sensor	135°F (57.2°C) fixed
Freeze Trouble	2WT-B and 4WT-B only: 41°F (5°C)
Sensitivity	2.5%/ft nominal
Input Terminals	14 to 22 AWG
Mounting	3½-inch octagonal back box 4-inch octagonal back box Single-gang back box 4-inch square back box with a plaster ring Direct mount to ceiling

LED Modes			Power-Up Sequence for LED Indication	
LED Mode	Green LED	Red LED	Condition	Duration
Power up	Blink every 10 seconds	Blink every 10 seconds	Initial LED status indication	80 seconds
Normal (standby)	Blink every 5 seconds	off		
Out of sensitivity	off	Blink every 5 seconds		
Freeze trouble	off	Blink every 10 seconds		
Alarm	off	Solid		

Ordering Information

Model	Thermal	Wiring	Alarm Current
2W-B	No	2-wire	130 mA max. limited by control panel
2WT-B	Yes	2-wire	130 mA max. limited by control panel
4W-B	No	4-wire	20 mA @ 12 V, 23 mA @ 24 V
4WT-B	Yes	4-wire	20 mA @ 12 V, 23 mA @ 24 V
Accessories			
2W-MOD2	2-wire loop test / maintenance module		RT Removal / replacement tool
SENS-RDR	Sensitivity reader		A77-AB2 Retrofit adapter bracket, 6.6 inch (16.76 cm) diameter



3825 Ohio Avenue • St. Charles, IL 60174
Phone: 800-SENSOR2 • Fax: 630-377-6495

©2009 System Sensor.
Product specifications subject to change without notice. Visit systemsensor.com for current product information, including the latest version of this data sheet.
A05-0318-007 • 6/09 • #2169