

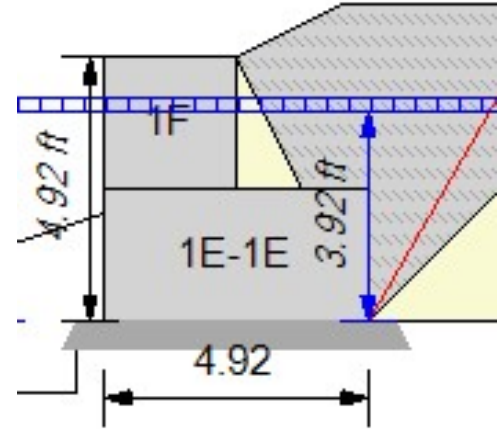

PRRWF20250845

UltraWall

Project: BPLC Properties - Inter Ave
 Location: Puyallup, WA
 Designer: KDH
 Date: 4/3/2025
 Section: 5.0 Wall
 Design Method: AASHTO_LRFD_2020
 Design Unit: UltraBlock: 1E-1E
 Seismic Acc: 0.550g



SOIL PARAMETERS	Φ	coh	γ	γ _{sat}
Select Soil:	36 deg	0 lbf/ft ²	135 lbf/ft ³	137 lbf/ft ³
Retained Soil:	30 deg	50 lbf/ft ²	120 lbf/ft ³	137 lbf/ft ³
Foundation Soil:	30 deg	50 lbf/ft ²	120 lbf/ft ³	137 lbf/ft ³
Leveling Pad:	40 deg	0 lbf/ft ²	140 lbf/ft ³	137 lbf/ft ³
Crushed Stone Lvlng Pad				

GEOMETRY

Design Height:	4.92 ft	Live Load:	0.00 lbf/ft ²
Wall Batter/Tilt:	0.00/ 0.00 deg	Live Load Offset:	0.00 ft
Embedment:	2.00 ft*	Live Load Width:	0.00 ft
Leveling Pad Depth:	0.50 ft	Dead Load:	0.0 lbf/ft ²
Slope Angle:	26.6 deg	Dead Load Offset:	0.0 ft
Slope Length:	2.0 ft	Dead Load Width:	0.00 ft
Slope Toe Offset:	0.0 ft	D.L. Embedment:	0.00 ft
Leveling Pad Width:	5.92 ft		
Vert δ on Single Dpth		Toe Slope Angle:	18.40
		Toe Slope Length:	10.00
		Toe Slope Bench:	0.00

Select Fill Offset: 0.00 ft
 Select Fill Angle: 45.00 deg.



* Note: For all designs the passive resistance in front of the wall units is ignored for sliding calculations.

Water

Front Height: 3.92 ft
 Internal Ht: 3.92 ft
 Drainage Depth: 1.00 ft

Calculations required to be provided by the Permittee on site for all Inspections

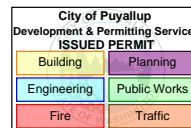

City of Puyallup
Building
REVIEWED
FOR
COMPLIANCE

SKinnear
 06/26/2025
 11:09:19 AM

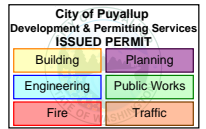

RESULTS (Static / Seismic)

CDR Sliding: 2.27 (lvlpd) / 2.53 CDR Brng: 2.75 / 6.25
 Eccentricity (e/L): 0.27 (e/L <= 0.33) / [0.28 (e/L <= 0.40)] Bearing: 1136 / 838 / 911 (Service)
 Ecc Internal(e/L): 0.05 (e/L <= 0.45)

Name	Elev.	ka	kae	Pae	Paw1	Paw2	Paw3	Pif	Pwd	(Pwr)	PaT	PaTs	CDRsl	seisCDRsl	e/L	Seis e/L (Pae/Pir)
1F	2.46	0.344	0.000	126	0	0	78	171	67	-67	78	382	32.01	25.01 / 23.35	0.05	0.00
1E-1E	0.00	0.342	0.529	450	23	181	197	429	479	-479	401	1789	2.27	2.53 / 2.65	0.25	0.00

Column Descriptions:

- ka: active earth pressure coefficient; kae: active seismic earth pressure coefficient
- Paw1: active earth pressure of soils above the water line
- Paw2: active earth pressures (1) of submerged soils below the water line
- Paw3: active earth pressures (2) of submerged soils below the water line
- Pwd: driving pressures of water from behind the face
- Pwr: resisting pressures of water in front of wall
- Pif: Inertia of the facing units, Pir: Inertia of the gravel fill behind the units.
- Paq: live surcharge earth pressure
- Paqd: dead surcharge earth pressure
- (PaC): reduction in load due to cohesion
- PaT: sum of all earth pressures
- CDRsl (lvIPad): 'Capacity/Demand Ratio' for sliding at each layer. (CDR sliding below the leveling pad)
- e/L: eccentricity/base width ratio
- e/L (Srvs): service state condition eccentricity/base width ratio
- %D/H: ratio of based depth to height (warning for narrow walls, < 35%)

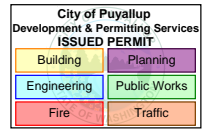

DESIGN DATA

Load Factors for Design

AASHTO Table 3.4.1-1 & 3.4.1-2

Load Case	Str_Max	Str_Min	Extreme Max	Extreme Min	Service
Str I Dead Load (DC)	1.25	0.90	1.00	1.00	1.00
Soil Load Driving (EH)	1.50	0.90	1.00	1.00	1.00
Str I Vert Earth Load (EV)	1.35	1.00	1.00	1.00	1.00
Dead Load Surcharge (ES)	1.50	0.75	1.00	1.00	1.00
Live Load (LL, PL, LS)	1.75	0.00	1.00	0.00	1.00

Application of Load Factors

Group	DC	EV	LS	EH	Probable Use
Strength I-a	0.90	1.00	1.75	1.50	BC/EC/SL
Strength I-b	1.25	1.35	1.75	1.50	BC (max. value)
Service I	1.00	1.00	1.00	1.00	Settlement

Notes: BC - Bearing Capacity; EC - Eccentricity; SL - Sliding

By Inspection:

- Strength I-a (minimum vertical loads and maximum horizontal loads) will govern for the case of sliding and eccentricity (overturning); and
- For the case of bearing capacity, maximum vertical loads will govern, and the factored loads must be compared for Strength I-b.

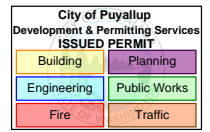

DESIGN DATA

Load Factors for Design

MINIMUM DESIGN REQUIREMENTS

Minimum embedment depth

Min_emb = 2.00 ft

INPUT DATA

Geometry

Wall Geometry

Design Height, top of leveling pad to finished grade at top of wall

H = 4.92 ft

Embedment, measured from top of leveling pad to finished grade

emb = 2.00 ft

Leveling Pad Depth

Thickness = 0.50 ft

Face Batter, measured from vertical

i = 0.00 deg

Slope Geometry

Back Slope Angle, measured from horizontal

β = 26.60 deg

Back Slope Toe Offset, measured from back of the face unit

STL_offset = 0.00 ft

Back Slope Length, measured from toe to crest

SL_Length = 2.00 ft

NOTE: If the back slope toe is offset or the slope breaks within three times the wall height, a Coulomb Trial Wedge method of analysis is used.

Toe Slope Angle, measured from horizontal

β = 18.40 deg

Toe Slope Crest Offset, measured from front of the face unit

STL_offset = 0.00 ft

Toe Slope Length, measured from crest to toe

SL_Length = 10.00 ft

Surcharge Loading

Live Load, assumed transient loading (e.g. traffic)

LL = 0.00 lbf/ft²

Live Load Offset, measured from back face of wall

LL_offset = 0.00 ft

Live Load Width, assumed strip loading

LL_width = 0.00 ft

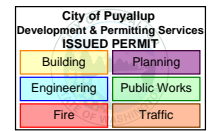

Soil Parameters

Retained Zone

Angle of Internal Friction $\Phi = 36.00$ deg
Cohesion $\text{coh} = 0.00$ lbf/ft²
Moist Unit Weight $\gamma = 135.00$ lbf/ft³

Backfill Zone

Angle of Internal Friction $\Phi = 30.00$ deg
Cohesion $\text{coh} = 50.00$ lbf/ft²
Moist Unit Weight $\gamma = 120.00$ lbf/ft³

Foundation

Angle of Internal Friction $\Phi = 30.00$ deg
Cohesion $\text{coh} = 50.00$ lbf/ft²
Moist Unit Weight $\gamma = 120.00$ lbf/ft³

Leveling Pad

Angle of Internal Friction $\Phi = 40.00$ deg
Cohesion $\text{coh} = 0.00$ lbf/ft²
Moist Unit Weight $\gamma = 140.00$ lbf/ft³

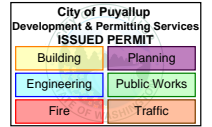

RETAINING WALL UNITS

STRUCTURAL PROPERTIES:

N is the normal force [or factored normal load] on unit to unit interface

The unit to unit shear is $N \times \tan(0.0) + 3619.6$

N is the normal force [or factored normal load] on the base unit

The default leveling pad to base unit shear is $0.8 * \tan(40)$, or 34 deg. [AASHTO LRFD 10.6.3.4-2] or may be the manufacturer supplied data.

[Note: concrete to concrete has a coefficient of $\Phi 0.6$ N.

Table of Values:

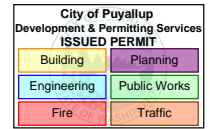

FORCES AND MOMENTS

The program resolves all the geometry into simple geometric shapes to make checking easier. All x and y coordinates are referenced to a zero point at the middle of the base block for eccentricity calculations.

LOADS FOR ECCENTRICITY ABOUT THE CENTER OF THE BASE

Name	Factor γ	Force (V)	Force (H)	X-len	Y-len	Mo	Mr
Face Blocks(W1)	1.00	1559.79		-1.765			-2753.11
Soil Wedge(W2)	1.00	563.08		-1.229			-692.12
Pa_h	1.00		381.26		1.771	675.35	
Pa_v	1.00	123.88		-2.458			-304.53
Sum V / H	1.00	2247	381		Sum Mom	675	-3750

W0: stone within units

W1: facing units

W2: soil wedge behind the face

X-Len: is measured from the center of the base (+) Driving, (-) Resisting.

Pa_h: horizontal earth pressure

Pa_v: vertical earth pressure

Pq_h: horizontal surcharge pressure

Pq_v: vertical surcharge pressure

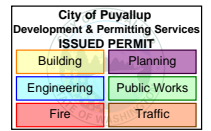

FORCES AND MOMENTS FACTORED FOR Str I-a

UltraWall increases all driving forces and reduces the resisting forces by the factors shown for Str I.

FACTORED LOADS: Str Ia

Name	FactorMax γ	FactorMin γ	ForceSldg (V)	ForceEcc (V)	Force (H)	X-len	Y-len	Mo	Mr
Face Blocks(W1)	1.25	0.90	1403.81	1403.81		-1.765			-2477.80
Soil Wedge(W2)	1.35	1.00	563.08	563.08		-1.229			-692.12
Paw_h	1.50				571.88		1.771	1013.02	
Paw_v		0.90	185.82	185.82		-2.458			-274.08
Sum V / H			2153	2153	572		Sum Mom	1013	-3627

FORCES AND MOMENTS FACTORED FOR Str I-b

UltraWall increase resisting forces and increases driving forces by the factors shown for Str I-b.

FACTORED LOADS: Str Ib

Name	Factor γ	Force (V)	Force (H)	X-len	Y-len	Mo	Mr
Face Blocks(W1)	1.25	1949.74		-1.765			-3441.39
Soil Wedge(W2)	1.35	760.16		-1.229			-934.36
Pa_h	1.50		571.88		1.771	1013.02	
Pa_v	1.50	185.82		-2.458			-456.80
Sum V / H		2896	572		Sum Mom	1013	-4833

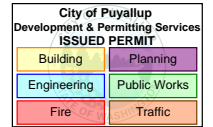

BASE SLIDING

Sliding at the base is checked at the block to leveling pad interface between the base block and the leveling pad.

Forces Resisting sliding

$$N = W1(DCr) + W2(EVr) + Pav(EHd)$$

$$(1,560 \times 0.90) + (563 \times 1.00) + (124 \times 1.50)$$

$$N = 2,153 \text{ lbf/ft}$$

Sliding between Concrete Units and Leveling Pad/Drain Mat (Rf1)

Resisting force at pad = (θ N tan(slope)) x RFsl

$$RF1 = (0.8 \times 2,153 \times \tan(40.00) + 0.0) \times 0.90$$

$$Rf1 = 1,301$$

Driving force is the horizontal component of

Pah(EHd)

$$DF = (381 \times 1.50)$$

$$Df = 572$$

$$CDR = (Rf1 / Df)$$

$$CDR = 2.27$$

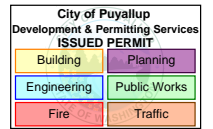

ROW TO ROW SLIDING

Sliding between rows is checked at the interface between two adjacent rows.

Details of the calculation are shown on the previous page. The leveling pad interaction is now replaced with the unit/unit interaction.

RESULTS TABLE FACTORED

Elev[ft]	N[lbf/ft]	Shear Intcpt	Resisting Force	Driving Force[lbf/ft]	CDR Sliding/Shear
2.46	559.67	3,257.59	3,559.82	111.22	32.01

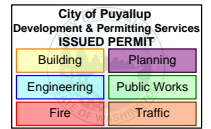

ECCENTRICITY

Eccentricity at the base is checked by assuming rotation by the block mass and the soil retained on the blocks. Allowable overturning can be defined by eccentricity (e/L).

Moments Resisting =

$$M1(DCr) + M2(EVr) + MPav(EHd)$$

$$((-2,753 \times 0.90) + (-692 \times 1.00) + (-305 \times 1.50))$$

$$Mr = 3,627 \text{ ft-lbs}$$

Moments Driving = MPah(EHd) + M0(EVd)

$$(675 \times 1.50) + (0 \times 1.35) + (0 \times 1.50)$$

$$Mo = 1,013 \text{ ft-lbs}$$

$$e = (Mr - Mo) / N$$

$$e = (3,627 - 1,013) / 2,153$$

$$e/L = 1.21 / 4.92$$

$$e = 1.21$$

$$e/L = 0.25$$

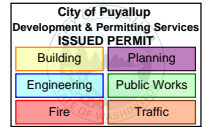

ROW TO ROW ECCENTRICITY

Eccentricity is checked by assuming rotation by the block mass and the soil retained on the blocks about the row below. Factored eccentricity can be defined by eccentricity/Length (e/L).

RESULTS TABLE FACTORED

Elev[ft]	Mr[ft lbf/ft]	Mo[ft lbf/ft]	Sum Vertical[lbf]	Ecc[ft]	BlockLength	Ecc/L
2.46	0.00	102.77	777.32	0.13	2.46	0.05

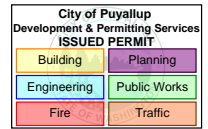

ECCENTRICITY AND BEARING

Eccentricity is the calculation of the distance of the resultant force away from the centroid of the mass. This measure is an indication of the overturning of the mass. UltraWall uses an allowable eccentricity of 9/20 L for concrete to concrete bearing surfaces and a concrete leveling pad (thickness > 1.0 ft), or L/3 for bearing on soil per the AASHTO LRFD guidelines. Eccentricity is still used as a guide to design in some design methods.

UltraWall calculates three eccentricities:

- 1) Maximum eccentricity (overturning) where it uses the maximum driving forces combined with the minimum resisting forces (see overturning) [Str I-a].
- 2) Maximum bearing where it uses the maximum driving forces combined with the maximum resisting forces [Str I-b].
- 3) Service: Maximum bearing where it uses the actual driving forces combined with the actual resisting forces in Service loading.

Calculation of Eccentricity for maximum bearing

$$\text{Moments resisting} = M1(\text{DCd}) + M2(\text{EVd}) + \text{MPa}(\text{EHd})$$

$$(-2,753 \times 1.25) + (-692 \times 1.35) + (-305 \times 1.50)$$

$$\text{Mr} = 4,833 \text{ ft-lbs}$$

$$\text{Moments driving} = + \text{MPah}(\text{EHd})$$

$$+ (675 \times 1.50)$$

$$\text{Mo} = 1,013 \text{ ft-lbs}$$

$$\text{Nb} = W1(\text{DCd}) + W2(\text{EVd}) + \text{WPa}(\text{EHd})$$

$$(1,560 \times 1.25) + (563 \times 1.35) + (124 \times 1.50)$$

$$\text{Nb} = 2,896 \text{ lbf/ft}$$

$$\text{N bearing} = W1(\text{DCd}) + W2(\text{EVd}) + \text{WPIVpad}(\text{EVd}) + \text{WPa}(\text{EHd})$$

$$(1,560 \times 1.25) + (563 \times 1.35) + (193 \times 1.35) + (124 \times 1.50)$$

$$\text{Nbrg} = 3,157 \text{ lbf/ft}$$

Calculate Eccentricity (absolute values used for parameters)

$$e = (\text{Mr} - \text{Mo}) / \text{Nb}$$

$$e = (4,833 - 1,013) / 2,896$$

$$e = 1.319$$

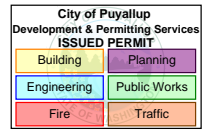

BEARING

Bearing Capacity Factors [Foundation]

$N_c = 30.140$ Myerhoff Eqn
 $N_q = 18.401$ Myerhoff Eqn
 $N_g = 22.402$ Vesic Eqn

Shape Factors [Foundation]

$S_c = 1.061$
 $S_q = 1.058$
 $S_g = 0.960$

Depth Correction Factor

$d_f = 1.136$

Modified Bearing Capacity Factors [Foundation]

$N_{cm} = N_c \times S_c = 31.980$
 $N_{qm} = N_q \times S_q = 22.107$
 $N_{gm} = N_g \times S_g = 21.506$

Water Correction Factor

$C_{wq} = 0.500$
 $C_{wg} = 0.500$

$B'f = B - 2e + \text{vlPad Thickness (Bearing area at foundation)}$

$B'f = 4.92 - 2 \times 1.32 + 0.50$

$B'f = 2.78 \text{ ft}$

$q = \text{embedment} \times \gamma$

$= 2.00 \times 120.00$

$q = 300.00 \text{ lbf/ft}^2$

Calculation of Bearing Pressures Foundation

$q_r = (c \times N_{cm} + q \times N_{qm} \times C_{wq} + 0.5 \times \gamma \times B'f \times N_{gm} \times C_{wg}) \times \text{RFbr}$

$[(50.000 \times 31.980) + (240 \times 22.107 \times 0.500) + (0.5 \times 120 \times 2.779 \times 21.506 \times 0.500)] \times 0.45$

Calculate Factored Bearing, q_r

Bearing Pressures (σ)

Calculated CDR for bearing

$q_r = 3,128.02 \text{ lbf/ft}^2$

$N_{brg}/B'f = 1,136.13 \text{ lbf/ft}^2$

$q_r/\sigma = 2.75$

Design	Sum Vert	Mo	Mr	e	Qal	Sigma	CDR
Strength I-b	3157	1013	-4833	1.319	3128	1136	2.75
Service	2440	675	-3750	1.368	3095	911	3.40

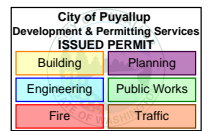

SEISMIC CALCULATIONS

The loads considered under seismic loading are primarily inertial loadings. The wave passes the structure putting the mass into motion and then the mass will try to continue in the direction of the initial wave. In the calculations you see the one dynamic earth pressure from the wedge of the soil behind the reinforced mass, and then all the other forces come from inertia calculations of the face put into motion and then trying to be held in place.

Design Ground Acceleration As = Fpae * PGA = 0.550

Assumed deformation = Def = 4.00 in
(with deformation, the kh is reduced by 50%)

Horizontal Acceleration kh = 0.275
Vertical Acceleration kv = 0.000

INERTIA FORCES OF THE STRUCTURE

Pif = (W1 * kh)
(1559.79 * 0.275) Pif = 428.94

SEISMIC THRUST

Coefficient of active seismic earth pressure Kae Kae = 0.529
D_Kae = Kae - Ka = (0.529 - 0.342) D_Kae = 0.000
Pae = 0.5*gamma*(H)^2 * DKae Pae = 0.00 lbf/ft
Pae_h = Pae*cos(delta) Pae_h = 0.00 lbf/ft
Pae_v = Pae*sin(delta) Pae_v = 0.00 lbf/ft

In AASHTO LRFD, two cases are looked at: 1) 100% Pae and 50% of Pir, and 2) 50% Pae and 100% Pir.

TABLE OF RESULTS FOR SEISMIC REACTIONS

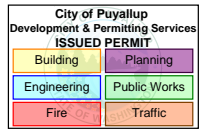

SEISMIC SLIDING

Details are only shown for sliding at the base of blocks, a check is made at the foundation level with the answer only shown.

The vertical resisting forces are

$$\text{Units}(1.0) + \text{SoilWedge}(1.0) + \text{Pa}_v(1.0)$$

$$(1560 * 1.0) + (563 * 1.0) + (124 * 1.0)$$

Note Pae_v changes between case 1 and case 2, to $\text{Pae}_v/2$

Case 1, 100% Pae & 50% Pir

$$\text{SumVs}_{\text{Pae}} = 2247$$

Case 2, 50% Pae & 100% Pir

$$\text{SumVs}_{\text{Pir}} = 2185$$

$$\text{Resisting force 1} = (\text{SumVs}_{\text{Pae}} * \tan(\text{slope}) + \text{intercept} * L) * \text{RFsl}$$

$$\text{FReS1} = 1508 \text{ lbf/ft}$$

$$\text{Resisting force 2} = (\text{SumVs}_{\text{Pir}} * \tan(\text{slope}) + \text{intercept} * L) * \text{RFsl}$$

$$\text{FReS2} = 1467 \text{ lbf/ft}$$

$$\text{The inertial force Pif} = \text{Face} * kh(1.0) + \text{Soil Wedge} * kh * (1.0)$$

$$\text{Driving force} = + \text{Pa}_h(1.0) + \text{Pif}_h/2(1.0)$$

[case 2 is 50% Pae , 100% Pir]

$$(381 * 1.0) + (429/2 * 1.0)$$

$$\text{FDrS1} = 596 \text{ lbf/ft}$$

$$\text{FDrS2} = 553 \text{ lbf/ft}$$

$$\text{CDR} = (\text{FReS1}/\text{FDrS1}) / (\text{FReS2}/\text{FDrS2})$$

$$\text{CDR} = 2.53 / 2.65$$

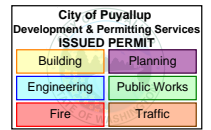

SEISMIC ECCENTRICITY

Eccentricity is rotation about the center of the wall and is a check on overturning.

Resisting Moment =
(case 2 is 50% Pae)

MomReS [Pae] = -3750 ft lbf/ft
MomReS [Pir] = -3445 ft lbf/ft

Driving Moment =
 $P_{a_h}(1.0) + P_{if_h}/2(1.0)$
 $(675 * 1.0) + (1266/2 * 1.0)$

MomDrS [Pae] = 675 ft lbf/ft
MomDrS [Pir] = 0 ft lbf/ft

$e = (M_r - M_o) / N$
 $e [Pae] = (3750 - 675) / 2247$
 $e/L = 0.28$
 $e [Pir] = (3445 - 0) / 2185$
 $e/L = 0.32$

$e = 1.37$
 $e = 1.58$

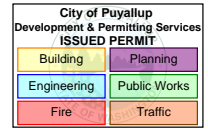

SEISMIC BEARING

Bearing is the ability of the foundation to support the mass of the structure.

$$Qult = c \cdot Nc + q \cdot Nq + 0.5 \cdot \gamma \cdot (B') \cdot Ng$$

where:

$$Nc = 30.14 \text{ Myerhoff Eqn}$$

$$Nq = 18.40 \text{ Myerhoff Eqn}$$

$$Ng = 22.40 \text{ Vesic Eqn}$$

$$c = 50 \text{ lbf/ft}^2$$

$$q = (\text{emb} + \text{lvl pad}) \cdot \gamma(\text{EVsr}) = 300.00 \text{ lbf/ft}^2$$

Pae Values (100% Pae, 50% Pir)

Calculate Factored Bearing, Qult (seismic)

Equivalent Footing Width, $B' = L - 2e + \text{Lvl pad}$

Bearing Pressure = $\sum Vs / B' + B + \text{LP depth} / 2 \cdot \text{LP depth} \cdot \gamma$

CDR for Bearing = $(Qults \cdot \text{RFbr}) / \text{Bearing}$

$$Qult = 5,980 \text{ lbf/ft}^2$$

$$B' = 2.68 \text{ ft}$$

$$q = 838.37 \text{ lbf/ft}^2$$

$$\text{CDR} = 7.13$$

Pir Values (50% Pae, 100% Pir)

Calculate Factored Bearing, Qult (seismic)

Equivalent Footing Width, $B' = L - 2e + \text{Lvl pad}$

Bearing Pressure = $\sum Vs / B' + B + \text{LP depth} / 2 \cdot \text{LP depth} \cdot \gamma$

CDR for Bearing = $(Qults \cdot \text{RFbr}) / \text{Bearing}$

$$Qult = 7,569 \text{ lbf/ft}^2$$

$$B' = 2.35 \text{ ft}$$

$$q = 956.14 \text{ lbf/ft}^2$$

$$\text{CDR} = 6.25$$

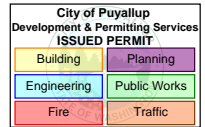

UltraWall

Project: BPLC Properties - Inter Ave
 Location: Puyallup, WA
 Designer: KDH
 Date: 4/3/2025
 Section: 7.5 Wall
 Design Method: AASHTO_LRFD_2020
 Design Unit: UltraBlock: 1
 Seismic Acc: 0.550g

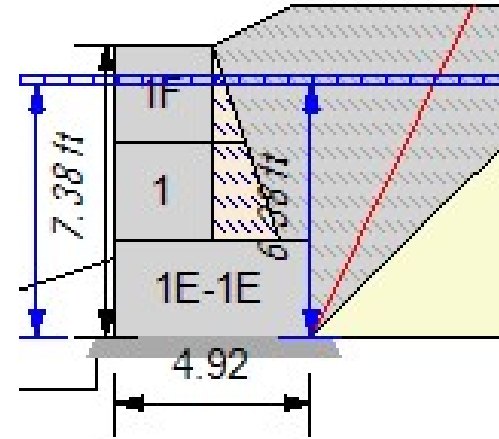

SOIL PARAMETERS	ϕ	coh	γ	γ_{sat}
Select Soil:	36 deg	0 lbf/ft ²	135 lbf/ft ³	137 lbf/ft ³
Retained Soil:	30 deg	50 lbf/ft ²	120 lbf/ft ³	137 lbf/ft ³
Foundation Soil:	30 deg	50 lbf/ft ²	120 lbf/ft ³	137 lbf/ft ³
Leveling Pad:	40 deg	0 lbf/ft ²	140 lbf/ft ³	137 lbf/ft ³
Crushed Stone Lvlng Pad				

GEOMETRY

Design Height:	7.38 ft	Live Load:	0.00 lbf/ft ²
Wall Batter/Tilt:	0.00/ 0.00 deg	Live Load Offset:	0.00 ft
Embedment:	2.00 ft*	Live Load Width:	0.00 ft
Leveling Pad Depth:	0.50 ft		
Slope Angle:	26.6 deg	Dead Load:	0.0 lbf/ft ²
Slope Length:	2.0 ft	Dead Load Offset:	0.0 ft
Slope Toe Offset:	0.0 ft	Dead Load Width:	0.00 ft
Leveling Pad Width:	5.92 ft	D.L. Embedment:	0.00 ft
Vert δ on Single Dpth		Toe Slope Angle:	18.40
		Toe Slope Length:	10.00
		Toe Slope Bench:	0.00
Select Fill Offset:	0.00 ft		
Select Fill Angle:	45.00 deg.		

* Note: For all designs the passive resistance in front of the wall units is ignored for sliding calculations.

Water

Front Height:	6.38 ft
Internal Ht:	6.38 ft
Drainage Depth:	1.00 ft

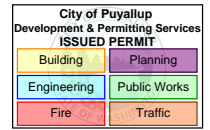

RESULTS (Static / Seismic)

CDR Sliding: 1.00 (Ivlpd) / 1.38 CDR Brng: 6.14 / 11.05
 Eccentricity (e/L): 0.12 (e/L <= 0.33) / [0.01 (e/L <= 0.40)] Bearing: 634 / 438 / 474 (Service)
 Ecc Internal(e/L): 0.18 (e/L <= 0.45)

Name	Elev.	ka	kae	Pae	Paw1	Paw2	Paw3	Pif	Pwd	(Pwr)	PaT	PaTs	CDRsl	seisCDRsl	e/L	Seis e/L (Pae/Pir)
1F	4.92	0.344	0.000	126	0	0	78	171	67	-67	78	383	31.97	25.00 / 23.36	0.05	0.00
1	2.46	0.309	0.000	396	0	0	280	300	480	-480	280	1540	9.48	10.27 / 14.25	0.18	0.00
1E-1E	0.00	0.500	0.759	1343	34	431	762	558	1270	-1270	1226	4324	1.00	1.38 / 2.83	0.12	0.00

Column Descriptions:

- ka: active earth pressure coefficient; kae: active seismic earth pressure coefficient
- Paw1: active earth pressure of soils above the water line
- Paw2: active earth pressures (1) of submerged soils below the water line
- Paw3: active earth pressures (2) of submerged soils below the water line
- Pwd: driving pressures of water from behind the face
- Pwr: resisting pressures of water in front of wall
- Pif: Inertia of the facing units, Pir: Inertia of the gravel fill behind the units.
- Paq: live surcharge earth pressure
- Paqd: dead surcharge earth pressure
- (PaC): reduction in load due to cohesion
- PaT: sum of all earth pressures
- CDRsl (IvlPad): 'Capacity/Demand Ratio' for sliding at each layer. (CDR sliding below the leveling pad)
- e/L: eccentricity/base width ratio
- e/L (Srvs): service state condition eccentricity/base width ratio
- %D/H: ratio of based depth to height (warning for narrow walls, < 35%)