

# DESIGN DRAWINGS

## Dry Filter

DFOCG-140814-NSB

DRY FILTER BOOTH, 14' W x 8' H x 14' L

Modular Buildings: Buildings which are constructed in factories and at other offsite locations and then shipped to Washington building sites must be approved by L&I. The building must have an L&I insignia prior to shipping from the factory. This includes equipment shelters that can be entered by personnel.

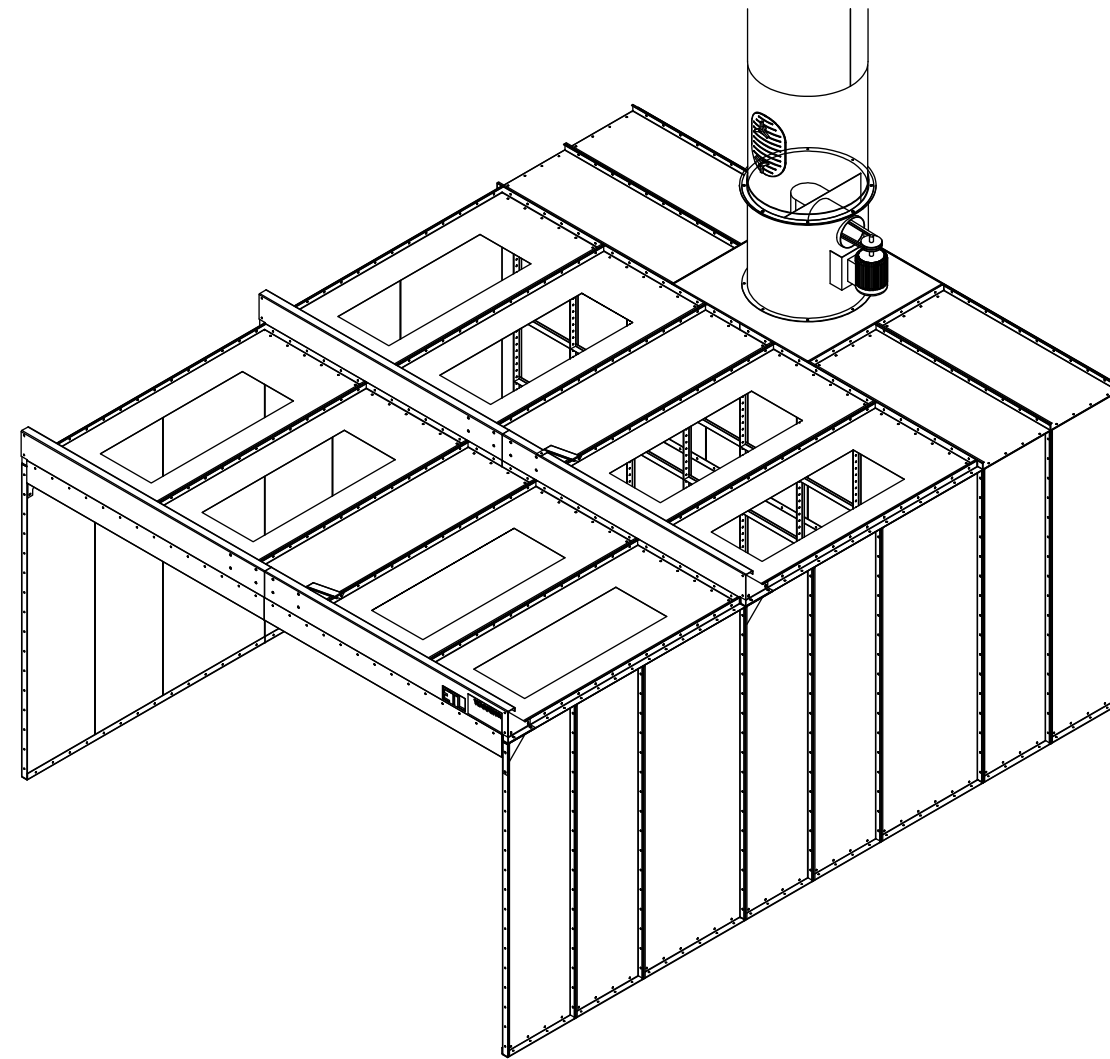
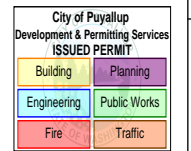

TABLE OF CONTENTS			
DRAWING	REV	TITLE	DESCRIPTION
01	0	GSN-NOTES	GENERAL STRUCTURE NOTES
02	0	GSN-DETAILS	STANDARD DETAILS
03	0	GENERAL ARRANGEMENT	GENERAL ARRANGEMENT
04	0	OVERALL ASSEMBLY	OVERALL ASSEMBLY
05	0	CA-EX-01	EXHAUST CHAMBER ASSEMBLY
06	0	CA-BAY-01	BAY ASSEMBLY
07	0	CA-BAY-02	BAY ASSEMBLY

IMPORTANT NOTE: This print and all information contained therein is the sole property of Global Finishing Solutions, LLC ("GFS"). It is not to be used or reproduced in any manner or submitted for other purposes for examination or approval by any authority without the written consent of GFS. Customer may contract or purchase order for GFS-manufactured equipment. Customer may make and retain copies of the print for information and reference in connection with an equipment order; however, this print is not intended or represented to be suitable for re-use by Customer or others on extensions of the order or on any other project. Any use without written verification is at Customer's sole risk and without liability to GFS, its affiliates, or agents.  
© Global Finishing Solutions, LLC 2017

**GLOBAL FINISHING SOLUTIONS**  
 12731 NORWAY ROAD  
 OSSEO, WI 54758 USA  
 800-848-8738  
 globalfinishing.com

SHIP TO  
 CODEL DOOR  
 1601 INDUSTRIAL WAY  
 PUYALLUP, WA 98371



**City of Puyallup Building REVIEWED FOR COMPLIANCE**  
 BSnowden  
 12/03/2025  
 11:59:39 AM



The approved construction plans, documents, and all engineering must be posted on the job at all inspections in a visible and readily accessible location.

Full sized legible color plans are required to be provided by the permittee on site for inspection.

Approval of submitted plans is not an approval of omissions or oversights by this office or non compliance with any applicable regulations of local government. The contractor is responsible for making sure that the building complies with all applicable codes and regulations of the local government.

SOLD TO  
 ADVANCED FINISHING SYSTEMS  
 7515 NE 33RD DRIVE  
 PORTLAND, OR 97211

ORDER/SERIAL NUMBER  
 U178152-B  
 DRAWING SET  
 R01  
 REVISION  
 0

PRCTI20251520

GENERAL STRUCTURAL NOTES

APPLY UNLESS NOTED ON DRAWINGS. IN CASE OF CONFLICT BETWEEN GSN, DETAILS AND PLANS, THE GREATER REQUIREMENTS GOVERN.

DESIGN INFORMATION:

BOOTH AND EQUIPMENT HAS BEEN DESIGNED BASED ON THE CURRENT EDITION OF THE INTERNATIONAL BUILDING CODE

RISK CATEGORY: II
SEISMIC IMPORTANCE FACTOR: IE=1

MAPPED SPECTRAL RESPONSE ACCELERATION:

Ss = 1.283
S1 = 0.441

SITE CLASS: D (ASSUMED)

SPECTRAL RESPONSE COEFFICIENT:

Sds = 1.027
SD1 = 0.547

SEISMIC DESIGN CATEGORY: D

SEISMIC-FORCE-RESISTING SYSTEMS:

STEEL ORDINARY MOMENT FRAMES (SINGLE STORY WITH DEAD LOAD TRIBUTARY TO ROOF DOES NOT EXCEED 20 PSF)
RESPONSE MODIFICATION FACTOR: R=3.50
SEISMIC RESPONSE COEFFICIENT: Cs=0.293

ALL OTHER SELF-SUPPORTING STRUCTURES, TANKS, OR VESSELS NOT COVERED ELSEWHERE IN TABLE 15.4-2
RESPONSE MODIFICATION FACTOR: R=1.25
SEISMIC RESPONSE COEFFICIENT: Cs=0.822

ANALYSIS PROCEDURE USED:

EQUIVALENT LATERAL FORCE PROCEDURE

BASIC WIND SPEED: 97 MPH

(PORTIONS OF EQUIPMENT THAT ARE OUTDOOR ONLY - IE STACKS AND STANDS)

BUILDING CATEGORY: INDOOR

EXPOSURE: C

DEAD LOADS: SELF-WEIGHT OF STRUCTURAL STEEL

IN ADDITION TO THE LOADS LISTED BELOW

INDUSTRIAL

- 5.0 PSF (ROOF)
- 3.5 PSF (WALLS)
- 3.5 PSF (PLENUM)

BOOTH ROOF LIVE LOADS: N/A PSF

LIVE LOADS: 300 LBS AT MIDPOINT OF FRAME BEAM

GROUND SNOW LOAD: 18 PSF

FDN INFORMATION:

ALL BEARING PLATES SUPPORTING THE BOOTH STRUCTURE MUST BE WITHIN 1/8" OF THE DESIGNATED DATUM POINT IN ACCORDANCE WITH ACI 117.1. GFS PERMITS SHIMMING UP TO 1/4" AT THE COLUMN BASES. ANY DEVIATIONS BEYOND THE SPECIFIED TOLERANCES THAT REQUIRE ADDITIONAL SHIMMING WILL BE CONSIDERED OUTSIDE THE SCOPE OF GFS U.N.O. IN THE DRAWINGS.

CAPACITY OF THE FDN/SLAB TO SUPPORT GFS BOOTHS AND EQUIPMENT IS NOT THE RESPONSIBILITY OF GFS.

ANCHORS INDICATED ARE BASED ON ASSUMPTIONS OF EXIST CONDITIONS (LISTED BELOW). THESE ASSUMPTIONS ARE MADE IN ORDER FOR GFS TO PROVIDE ANCHOR BOLT HOLES IN THE BASE PLATES AND PANELS. EXIST CONDITIONS SHOULD BE VERIFIED BY THE OWNER AND ANY DEVIATIONS SHOULD BE CONVEYED TO GFS PRIOR TO FABRICATION.

3/8"Ø SCREW ANCHOR - 3/8"Ø DEWALT SCREW-BOLT+ SCREW ANCHORS EMBEDDED 2 1/2" PER ICC ESR-3889 TO SECURE PANELS TO CONC. IN LIEU OF THE DEWALT ANCHOR, 3/8"Ø HILTI KWIK HUS-EZ SCREW ANCHORS EMBEDDED 2 1/2" PER ICC ESR-3027 MAY BE USED. EACH WALL/BAY IS REQUIRED TO HAVE ANCHORS AT 18" O.C. MAX, U.N.O. EACH WALL SHALL HAVE (1) ANCHOR 3" MAX FROM END OR CORNER AND A MIN OF (2) ANCHOR PER WALL/BAY. INSTALL ANCHORS PER MFR'S RECOMMENDATION. SEE DETAILS FOR ADDITIONAL INFORMATION. A PREAPPROVED ANCHOR WITH A CAPACITY EQUAL TO OR GREATER THAN THE SPECIFIED ANCHOR AND WITH A CURRENT ICC REPORT MAY BE USED IN LIEU OF THE ANCHOR SPECIFIED. ALL OTHER RESTRICTIONS (INCLUDING BUT NOT LIMITED TO EDGE DISTANCE AND EMBEDMENT) SHALL BE CONSIDERED.

3/8"Ø WEDGE ANCHOR - 3/8"Ø DEWALT POWER-STUD+ SD2 WEDGE ANCHORS EMBEDDED 2 3/8" MIN PER ICC ESR-2502. IN LIEU OF THE DEWALT ANCHOR, 3/8"Ø HILTI KWIK BOLT T22 WEDGE ANCHORS EMBEDDED 2 1/2" MIN PER ICC ESR-4266 MAY BE USED. SEE DETAILS FOR NUMBER OF ANCHORS REQUIRED AND ADDITIONAL INFORMATION. INSTALL ANCHORS PER MFR'S RECOMMENDATION. A PREAPPROVED ANCHOR WITH A CAPACITY EQUAL TO OR GREATER THAN THE SPECIFIED ANCHOR AND WITH A CURRENT ICC REPORT MAY BE USED IN LIEU OF THE ANCHOR SPECIFIED. ALL OTHER RESTRICTIONS (INCLUDING BUT NOT LIMITED TO EDGE DISTANCE AND EMBEDMENT) SHALL BE CONSIDERED.

ANCHOR SPECIFICATION IS BASED ON THE FOLLOWING ASSUMPTIONS OF EXIST CONDITIONS:

- MIN CONC COMPRESSIVE STRENGTH IS 2500 PSI.
-- MIN SLAB DEPTH IS 4".

COLD-FORMED STEEL:

ALL COLD-FORMED STEEL MEETS THE REQUIREMENTS OF THE LATEST EDITION OF THE AISI SPECIFICATION FOR THE DESIGN OF COLD-FORMED STEEL STRUCTURAL MEMBERS. ALL COLD-FORMED STEEL IS COMMERCIAL GRADE WITH A YIELD STRENGTH OF 32KSI AND A TENSILE STRENGTH OF 40KSI. 304 AND 316 STAINLESS STEEL PER ASTM A240 HAS A YIELD STRENGTH OF 25KSI AND A TENSILE STRENGTH OF 70KSI.

STRUCTURAL STEEL:

ALL STRUCTURAL STEEL FABRICATION AND CONSTRUCTION COMPLY WITH THE LATEST AISC HANDBOOKS AND CODES. ALL STEEL IS ASTM A36, EXCEPT AS FOLLOWS:
-- WIDE FLANGE SECTIONS - ASTM A992,
-- PIPE SECTIONS - ASTM A53 GRADE B,
-- HSS SECTIONS - ASTM A500 GRADE B
-- BOLTS ARE A325-N AND SHALL BE SNUG-TIGHTENED.

WELDING:

WELDERS HOLD CURRENT VALID CERTIFICATES AND HAVE CURRENT EXPERIENCE IN TYPE OF WELD CALLED FOR. STRUCTURAL STEEL WELDING WITH LOW HYDROGEN TYPE, E70 AND E60 FOR LIGHT GAUGE STEEL. STRUCTURAL STEEL WELDING CONFORMS TO THE "STRUCTURAL WELDING CODES-STEEL" AWS D1.1, CURRENT EDITION.

Welding to be completed by an individual or fabricator who is WABO certified or approved by the Building Official to perform the work. All welds must be inspected and approved by a WABO certified special inspector.

ROOF ACCESS RESTRICTIONS:

THE ROOFS OF GFS EQUIPMENT ARE NOT DESIGNED OR INTENDED TO BE WALKED UPON OR TO SUPPORT WEIGHT OF ANY KIND. AS DESIGNED AND MANUFACTURED, THE EQUIPMENT ROOFS DO NOT MEET THE MINIMUM REQUIREMENTS OF A SAFE WALKING AND/OR WORKING SURFACE UNDER OSHA 1910.22. UNDER NO CIRCUMSTANCES SHOULD THE ROOF BE USED BY MAINTENANCE PERSONNEL OR OTHERS FOR WALKING, STANDING, OR STORAGE OF ANY KIND.

WHEN NECESSARY, ROOF ACCESS SHOULD BE SECURED THROUGH THE USE OF A PROPERLY SUPPORTED PLATFORM THAT SATISFIES THE MINIMUM LOAD REQUIREMENTS SPECIFIED BY ASCE 7 (MINIMUM DESIGN LOADS AND ASSOCIATED CRITERIA FOR BUILDINGS AND OTHER STRUCTURES) AND ASCE 37 (DESIGN LOADS ON STRUCTURES DURING CONSTRUCTION).

ADDITIONALLY, PERSONNEL SHOULD ALWAYS UTILIZE APPROPRIATE FALL SAFETY PROTOCOLS WHEN USING AN ELEVATED PLATFORM. USE OF THE ROOF IN A CONTRARY MANNER MAY RESULT IN INJURY AND/OR DEATH.

SPECIAL INSPECTION INFORMATION:

SPECIAL INSPECTION SHALL BE REQUIRED FOR THE FOLLOWING TYPES OF WORK AND SHALL BE IN COMPLIANCE WITH IBC SECTION 1705:

- 1. POST-INSTALLED ANCHORS INTO HARDENED CONCRETE. PERIODIC INSPECTION REQUIRED.
2. HIGH STRENGTH BOLTING. OBSERVATION PRIOR TO AND DURING BOLTING IS NOT REQUIRED. EACH CONNECTION SHALL BE INSPECTED AFTER BOLTING.
3. FIELD WELDING. IF REQUIRED. RANDOM OBSERVATION PRIOR TO AND DURING WELDING. EACH WELD SHALL BE INSPECTED AFTER WELDING.
4. STRUCTURAL STEEL IN THE SEISMIC FORCE-RESISTING SYSTEMS

STATEMENT OF SPECIAL INSPECTION:

- A. THIS STATEMENT OF SPECIAL INSPECTIONS SHALL BE SUBMITTED IN ACCORDANCE WITH SECTION 1704.3 OF THE IBC.
B. THIS STATEMENT SHALL INCLUDE A SCHEDULE OF SPECIAL INSPECTION SERVICES APPLICABLE TO THIS PROJECT.

THE SPECIAL INSPECTOR(S) SHALL KEEP RECORDS OF ALL INSPECTIONS AND SHALL FURNISH INTERIM INSPECTION REPORTS TO THE BUILDING OFFICIAL AND TO THE REGISTERED DESIGN PROFESSIONAL IN RESPONSIBLE CHARGE ON A BI-WEEKLY BASIS. DISCREPANCIES SHALL BE BROUGHT TO THE IMMEDIATE ATTENTION OF THE CONTRACTOR FOR CORRECTION. IF THE DISCREPANCIES ARE NOT CORRECTED, THE DISCREPANCIES SHALL BE BROUGHT TO THE ATTENTION OF THE BUILDING OFFICIAL AND THE REGISTERED DESIGN PROFESSIONAL IN RESPONSIBLE CHARGE PRIOR TO COMPLETION OF THAT PHASE OF WORK. A FINAL REPORT OF SPECIAL INSPECTIONS DOCUMENTING REQUIRED SPECIAL INSPECTIONS AND CORRECTIONS OF ANY DISCREPANCIES NOTED IN THE INSPECTIONS SHALL BE SUBMITTED TO THE BUILDING OFFICIAL AND REGISTERED DESIGN PROFESSIONAL IN RESPONSIBLE CHARGE AT THE CONCLUSION OF THE PROJECT.

THE SPECIAL INSPECTION PROGRAM DOES NOT RELIEVE THE CONTRACTOR OF THE RESPONSIBILITY TO COMPLY WITH THE CONTRACT DOCUMENTS. JOBSITE SAFETY AND MEANS AND METHOD OF CONSTRUCTION ARE SOLELY THE RESPONSIBILITY OF THE CONTRACTOR.

OUTDOOR USE:

THE EQUIPMENT IN THESE DOCUMENTS ARE NOT DESIGNED FOR OUTDOOR USE. IN THE EVENT THAT SUCH APPLICATIONS AND/OR USES ARE CONTEMPLATED (IE ANY PORTION OF THE EQUIPMENT IS EXPOSED TO THE ELEMENTS, NOT INCLUDING STACKS), THE PURCHASER OF THE EQUIPMENT IS RESPONSIBLE FOR NOTIFYING GFS SO THAT ADDITIONAL STRUCTURAL ANALYSIS CAN BE PERFORMED AND THE NECESSARY MODIFICATIONS CAN BE MADE.

ABBREVIATIONS:

- A.F.G. - ABOVE FINISH GRADE
AMU - AIR MAKE-UP UNIT
BLDG - BUILDING
CONC - CONCRETE
ESOW - EACH SIDE OF WEB
EXIST - EXISTING
FDN - FOUNDATION
GA - GAUGE
GR5 - GRADE 5
IBC - INTERNATIONAL BUILDING CODE
LBS - POUNDS
MAX - MAXIMUM
MFR - MANUFACTURER
MIN - MINIMUM
NS/FS - NEAR SIDE AND FAR SIDE
O.C. - ON CENTER
OSHA - OCCUPATIONAL SAFETY AND HEALTH ADMINISTRATION
PLF - POUNDS PER LINEAR FOOT
PSF - POUNDS PER SQUARE FOOT
T/B - TOP AND BOTTOM
TYP - TYPICAL
U.N.O. OR UNO - UNLESS NOTED OTHERWISE
WF - WIDE FLANGE

GLOBAL FINISHING SOLUTIONS
12731 NORWAY ROAD
OSSEO, WI 54758 USA
800-848-8738
globalfinishing.com

IMPORTANT NOTE: This print and all information contained herein is the sole property of Global Finishing Solutions, LLC ("GFS"). It is not to be used or reproduced in any manner or submitted to other parties for examination without the express written approval of GFS pursuant to a fully-executed contract or purchase order for GFS-manufactured equipment. Customer may make and retain copies of the print for information and reference in connection with an equipment order; however, this print is not intended or represented to be suitable for reuse by Customer or others on extensions of the order for any GFS equipment. Global Finishing Solutions, LLC is not responsible for any use of this print without written verification is at Customer's sole risk and without liability to GFS. © Global Finishing Solutions, LLC 2025

Table with 6 columns: SCALE, NTS, DRAWN BY, TL, DATE, REVIEW BY. Values: NTS, TL, 7/28/2025, CFM, 7/31/2025

Table with 2 columns: SHIP TO, SOLD TO. Values: CODEL DOOR, 1601 INDUSTRIAL WAY, PUYALLUP, WA 98371

Table with 2 columns: MODEL INFO, ORDER/SERIAL NUMBER. Values: SE-NOTES, GENERAL STRUCTURAL NOTES, U178152-B

Table with 2 columns: DRAWING SET, REVISION. Values: R01, 0

Table with 2 columns: DRAWING, VALUE. Values: 01

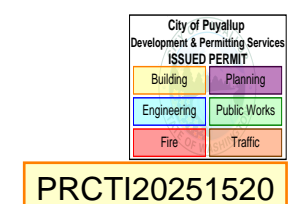

- 1. FILTER RACK.
- 2. FLOOR CHANNEL. FIELD DRILL AS NECESSARY FOR ANCHOR INSTALLATION
- 3. SEE 3/8"φ SCREW ANCHOR NOTE ON GSN.
- 4. EXIST SLAB ON GRADE. 4" MIN CONC THICKNESS. VERIFICATION OF SLAB NOT BY GFS.

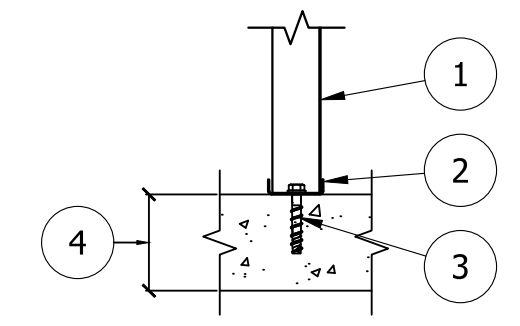

DF5B FILTER RACK / FLOOR CHANNEL TO SLAB CONNECTION

- 1. SINGLE SKIN PANEL.
- 2. 5/16"φ A307 BOLTS AT 6" O.C. TYP.

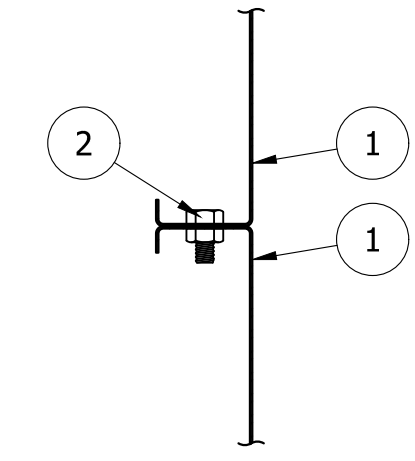

SCALE  
3" = 1'-0"

DF1 PANEL TO PANEL CONNECTION

- 1. SINGLE SKIN WALL PANEL.
- 2. FILTER RACK FRAMING.
- 3. 18GA STRUT.
- 4. (2) 5/16"φ A307 BOLTS.
- 5. (1) 5/16"φ A307 BOLT.

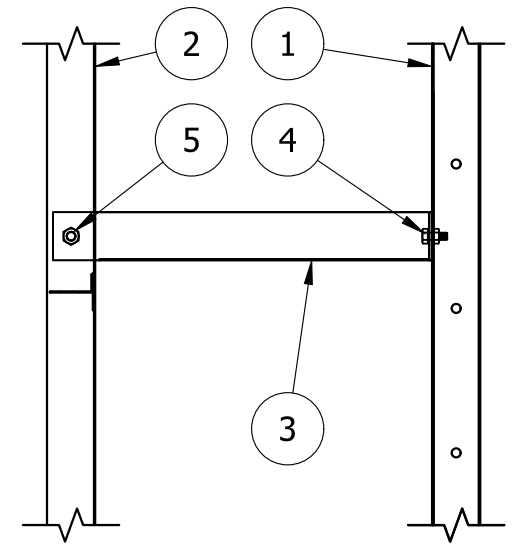

DF5B FILTER RACK TO WALL STRUT

- 1. SINGLE SKIN WALL PANEL.
- 2. SINGLE SKIN BOOTH ROOF PANEL.
- 3. TIE ANGLE - 2x2x14GA.
- 4. 5/16"φ BOLTS AT 6" O.C. TYP WHERE SHOWN.

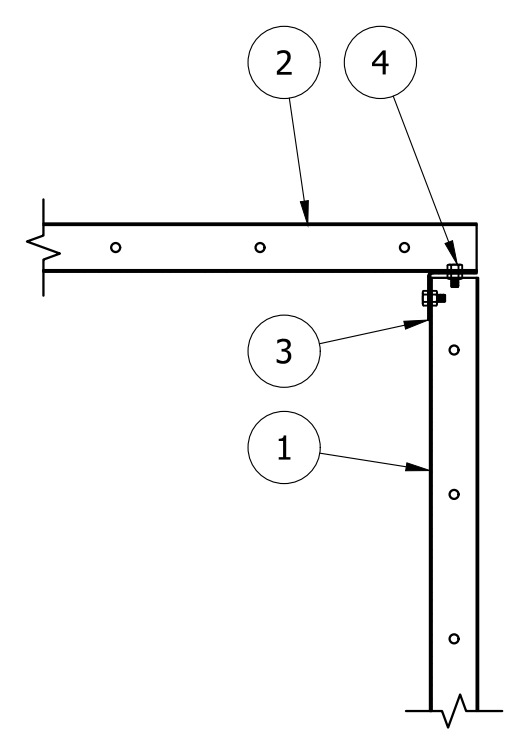

DF1 PANEL TO PANEL CONNECTION

- 1. SINGLE SKIN BOOTH ROOF PANEL.
- 2. 12GA "J" BEAM x 10" DEEP.
- 3. 18GA BRACE - LOCATE BETWEEN PANELS NEAREST TO MID-SPAN.
- 4. 5/16"φ A307 BOLT - FIELD DRILL.
- 5. 10GA SPLICE CHANNEL x 5 1/2" DEEP x 30" LONG.
- 6. MID-SPAN.
- 7. (4) 1/2"φ A325 BOLTS EACH SIDE OF SPLICE.

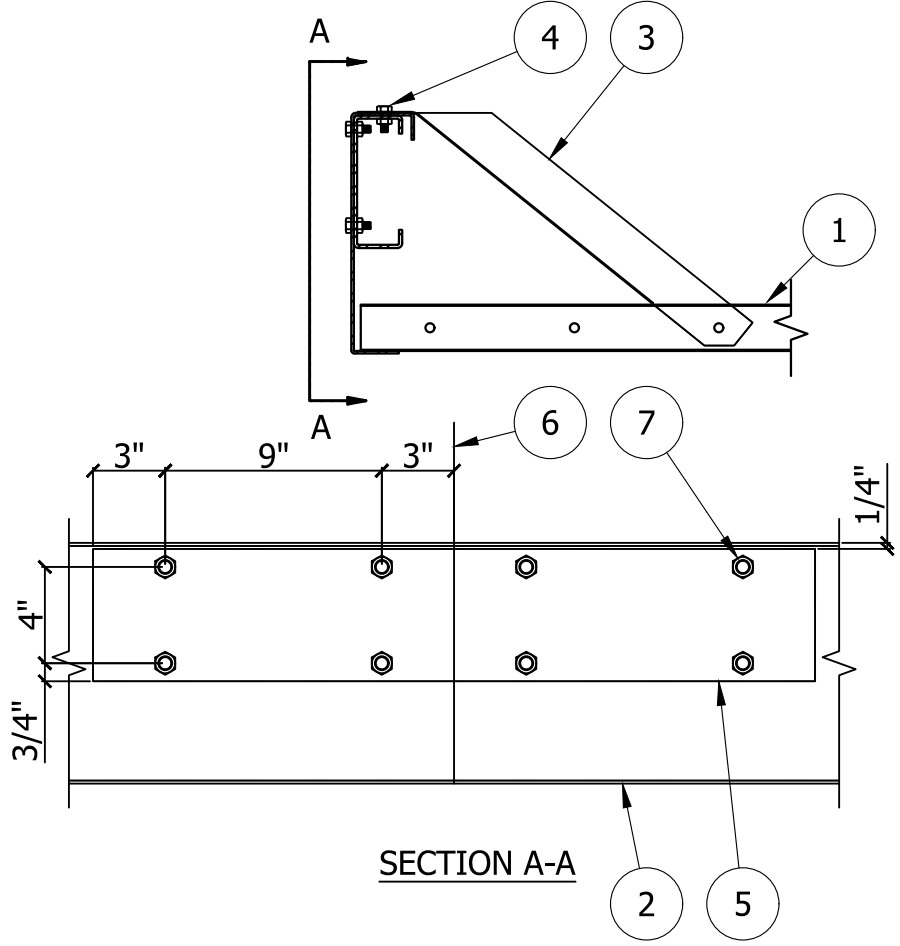

DF4A FILTER RACK TO WALL STRUT

- 1. FILTER RACK FRAMING.
- 2. 5/16"φ A307 BOLTS AT 6" O.C.

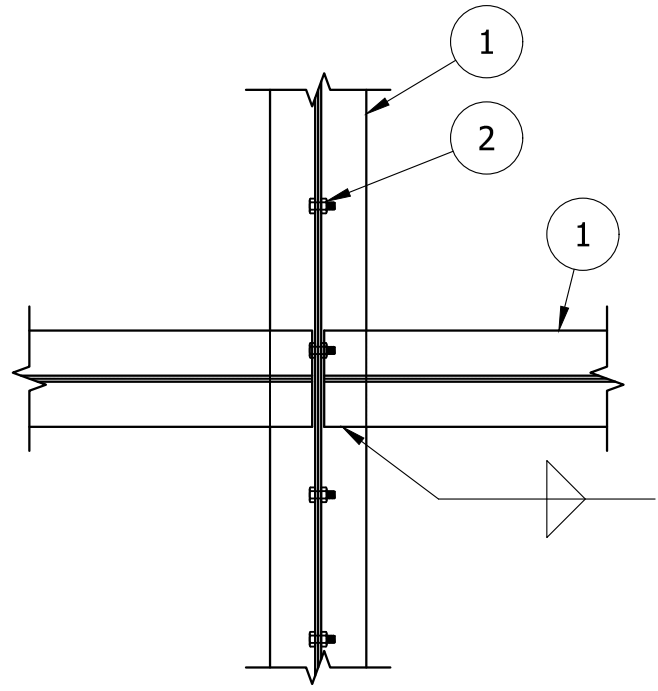

DF3C WALL/ROOF TIE

Welding to be completed by an individual or fabricator who is WABO certified or approved by the Building Official to perform the work. All welds must be inspected and approved by a WABO certified special inspector.

- 1. SINGLE SKIN BOOTH ROOF PANEL.
- 2. 12GA "J" BEAM x 10" DEEP.
- 3. 18GA BRACE - LOCATE BETWEEN PANELS NEAREST TO MID-SPAN.
- 4. 5/16"φ A307 BOLT - FIELD DRILL.
- 5. 10GA SPLICE CHANNEL x 5 1/2" DEEP x 30" LONG.
- 6. MID-SPAN.
- 7. (4) 1/2"φ A325 BOLTS EACH SIDE OF SPLICE.
- 8. BENT SHEET LEDGER ANGLE - 2x2x14GA.
- 9. 5/16"φ BOLTS AT 6" O.C.

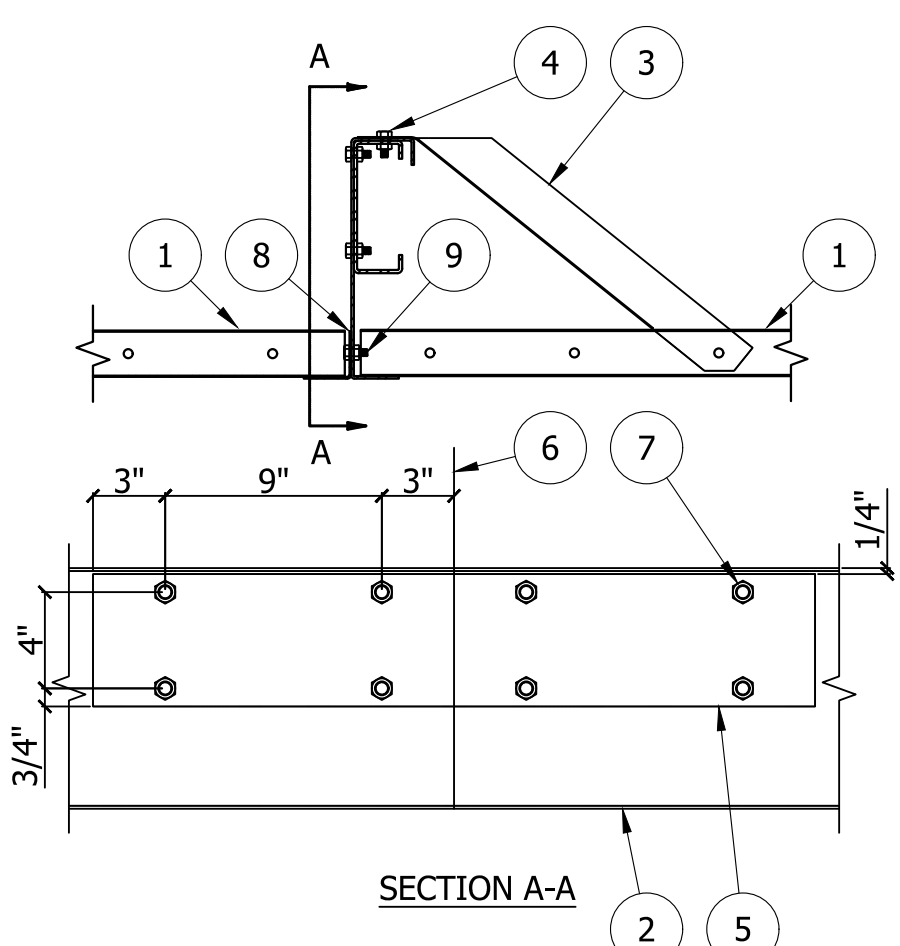

DF2A ROOF BEAM (WW GREATER THAN 10FT AND UNDER 20FT)

- 1. MAY NEED TO REMOVE BOLT AND NUT FOR INSTALLATION OF ANCHOR.
- 2. SEE 3/8"φ SCREW ANCHOR NOTES ON GSN.
- 3. EXIST SLAB ON GRADE. 4" MIN CONC THICKNESS. VERIFICATION OF SLAB NOT BY GFS.
- 4. SINGLE SKIN PANEL.
- 5. BASE TIE ANGLE

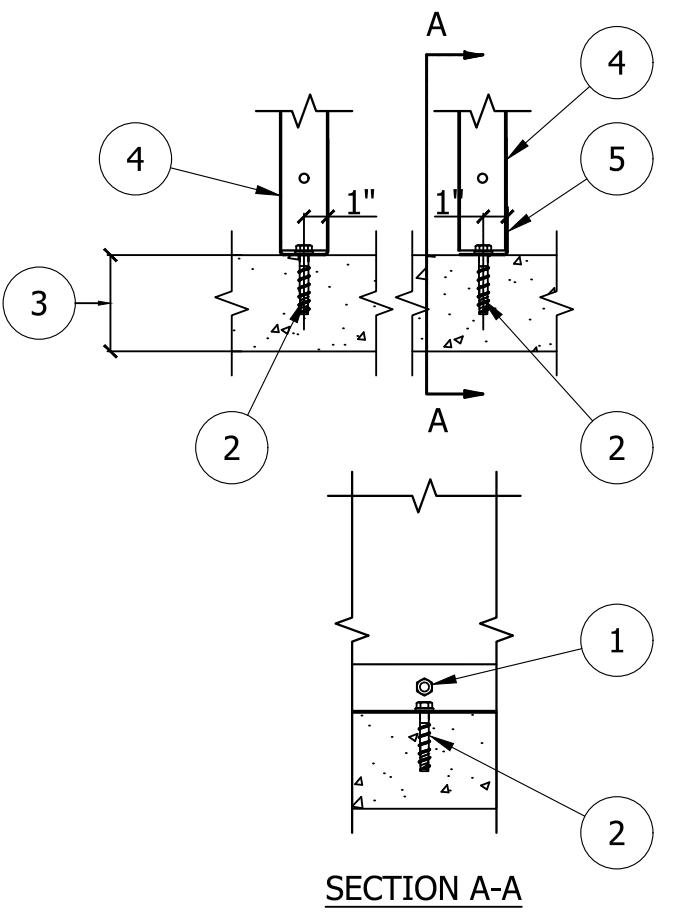

DF4B FILTER RACK

- 1. SINGLE SKIN BOOTH ROOF PANEL.
- 2. 12GA "J" BEAM x 10" DEEP.
- 3. 18GA BRACE - LOCATE BETWEEN PANELS NEAREST TO MID-SPAN.
- 4. 5/16"φ A307 BOLT - FIELD DRILL.
- 5. 10GA SPLICE CHANNEL x 5 1/2" DEEP x 30" LONG.
- 6. MID-SPAN.
- 7. (4) 1/2"φ A325 BOLTS EACH SIDE OF SPLICE.
- 8. BENT SHEET LEDGER ANGLE - 2x2x14GA.
- 9. 5/16"φ BOLTS AT 6" O.C.

DF2B ROOF BEAM (WW GREATER THAN 10FT AND UNDER 20FT)

DF5A PANEL OR TIE ANGLE TO SLAB CONNECTION

**GLOBAL FINISHING SOLUTIONS**  
 12731 NORWAY ROAD  
 OSSEO, WI 54758 USA  
 800-848-8738  
 globalfinishing.com

IMPORTANT NOTE: This print and all information contained herein is the sole property of Global Finishing Solutions, LLC ("GFS"). It is not to be used or reproduced in any manner or submitted to other parties for examination without the express written approval of GFS pursuant to a fully-executed contract or purchase order for GFS-manufactured equipment. Customer may make and retain copies of the print for information and reference in connection with an equipment order; however, this print is not intended or represented to be suitable for reuse by Customer or others on extensions of the order without the express written approval of GFS. No liability shall be assumed by GFS for any use without written verification is at Customer's sole risk and without the express written approval of GFS. © Global Finishing Solutions, LLC 2025

SCALE	NTS	DRAWN BY	TL	DATE	7/28/2025	REVIEW BY	CFM	REVIEW DATE	7/31/2025
-------	-----	----------	----	------	-----------	-----------	-----	-------------	-----------

MODEL INFO	SE-DETAILS	SHIP TO	CODEL DOOR
	STANDARD DETAILS	SOLD TO	1601 INDUSTRIAL WAY
			PUYALLUP, WA 98371
			ADVANCED FINISHING SYSTEMS INC
			7515 NE 33RD DRIVE
			PORTLAND, OR 97211
			ORDER/SERIAL NUMBER
			U178152-B
			DRAWING SET
			R01
			REVISION
			0
			DRAWING
			02

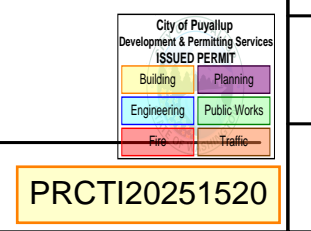

- NOTE:
- BOOTH IS FABRICATED FROM 18 GAGE GALVANIZED SHEET STEEL; PRE-PUNCHED AND COMPANION FLANGED FOR BOLT TOGETHER ASSEMBLY.
  - SOLENOID VALVE REQUIRED FOR INTERLOCKING SPRAY AIR WITH LIGHT LIMIT SWITCH AND EXHAUST. (VALVE CAN BE ORDERED AS AN OPTION FROM GFS)
  - DUCT SUPPORT NOT SUPPLIED OR DESIGNED BY GFS. EQUIPMENT IS NOT DESIGNED TO SUPPORT DUCT. DUCT SUPPORTS SHALL BE DESIGNED TO RELIEVE THE EQUIPMENT OF ALL DUCT LOAD.
  - WALL SHUTTER, IF APPLICABLE, DOES NOT MEET NFPA CODE. DISCHARGE POINT MUST BE 6' FROM EXTERIOR WALL OR ROOF.
  - INCLUDED BUT NOT SHOWN:
    - MANOMETER
    - 1/2" SOLENOID VALVE
  - CONTROLS FOR "B" INCLUDED ON "F".

EXHAUST DUCT SHALL BE INSTALLED IN ACCORDANCE WITH ALL LOCAL CODES.

**NATIONAL FIRE PREVENTION ASSOCIATION**

- AIR EXHAUSTED TO THE ATMOSPHERE FROM LIQUID SPRAY OPERATIONS SHALL BE CONDUCTED BY DUCTS DIRECTLY TO THE OUTSIDE OF THE BUILDING.
- EXHAUST DUCTS SHALL FOLLOW THE MOST DIRECT ROUTE TO THE POINT OF DISCHARGE BUT SHALL NOT PENETRATE A FIRE WALL.
- THE EXHAUST DISCHARGE SHALL BE DIRECTED AWAY FROM ANY FRESH AIR INTAKES.
- THE EXHAUST DUCT SHALL BE AT LEAST 6 FT. (1830 MM) FROM ANY EXTERIOR WALL OR ROOF.
- THE EXHAUST DUCT SHALL NOT DISCHARGE IN THE DIRECTION OF ANY COMBUSTIBLE CONSTRUCTION THAT IS WITHIN 25 FT. (7625 MM) OF THE EXHAUST DUCT DISCHARGE POINT NOR SHALL IT DISCHARGE IN THE DIRECTION OF ANY UNPROTECTED OPENING IN ANY NONCOMBUSTIBLE OR LIMITED-COMBUSTIBLE CONSTRUCTION THAT IS WITHIN 25 FT. (7625 MM) OF THE EXHAUST DUCT DISCHARGE POINT.

**INTERNATIONAL FIRE CODE**

- THE TERMINATION POINT FOR EXHAUST DUCTS DISCHARGING TO THE ATMOSPHERE SHALL NOT BE LESS THAN THE FOLLOWING DISTANCES:
- DUCTS CONVEYING EXPLOSIVE OR FLAMMABLE VAPORS, FUMES OR DUSTS: 30 FT. (9144 MM) FROM THE PROPERTY LINE; 10 FT. (3048 MM) FROM OPENINGS INTO THE BUILDING; 6 FT. (1830 MM) FROM EXTERIOR WALLS OR ROOFS; 30 FT. (9144 MM) FROM COMBUSTIBLE WALLS OR OPENINGS INTO THE BUILDING WHICH ARE IN THE DIRECTION OF THE EXHAUST DISCHARGE; 10 FT. (3048 MM) ABOVE THE ADJOINING GRADE.

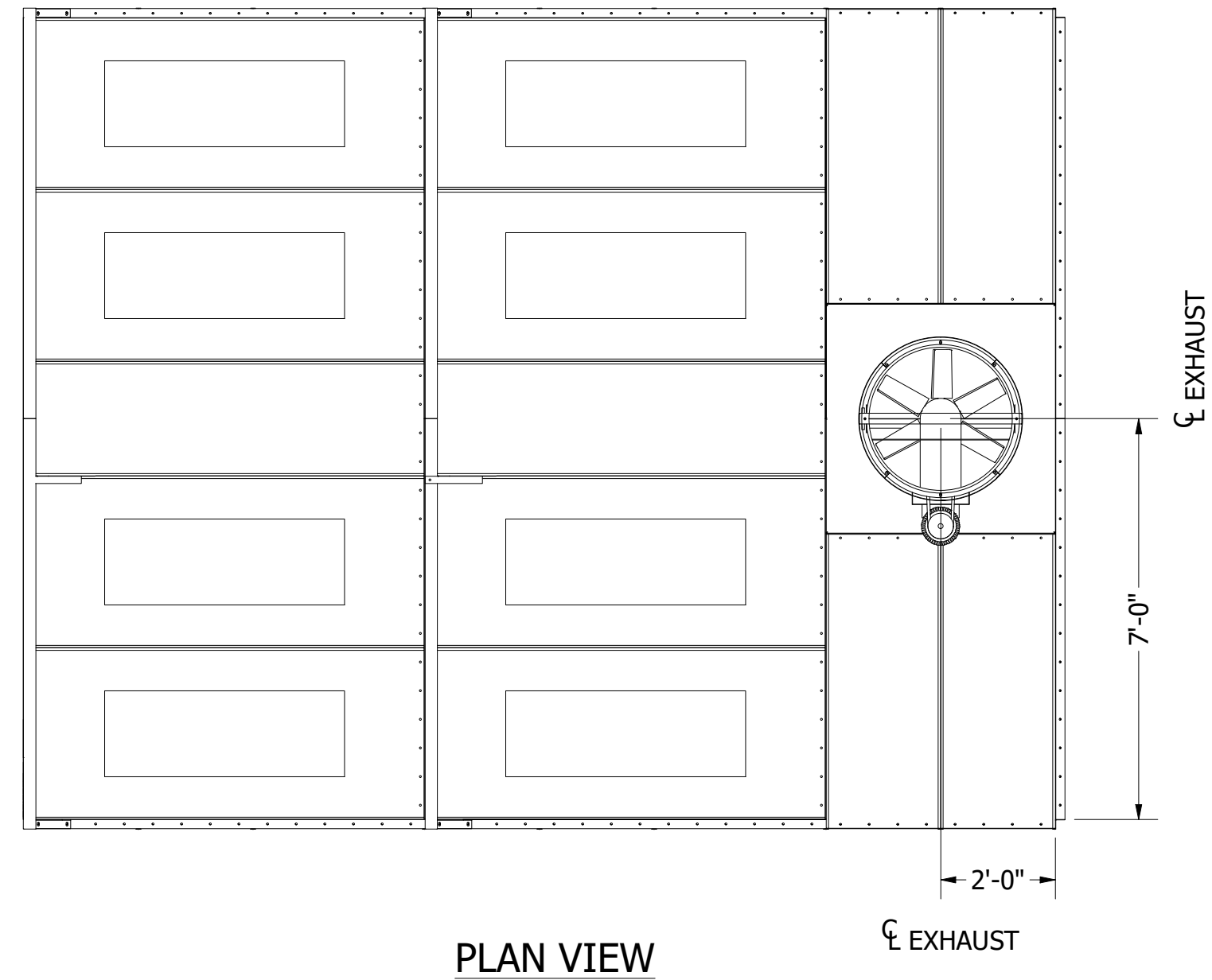

PLAN VIEW

THE EXHAUST FAN HAS BEEN SIZED WITH AN EXTERNAL STATIC PRESSURE (ESP) OF: 0.50", OF WHICH, AN ALLOWANCE OF 0.50" OF STATIC PRESSURE HAS BEEN MADE AVAILABLE FOR CUSTOMER PROVIDED DUCT. IF THE DUCT ALLOWANCE IS NOT ACCURATE, PLEASE CONSULT GFS FOR RESIZING OF THE FAN(S).

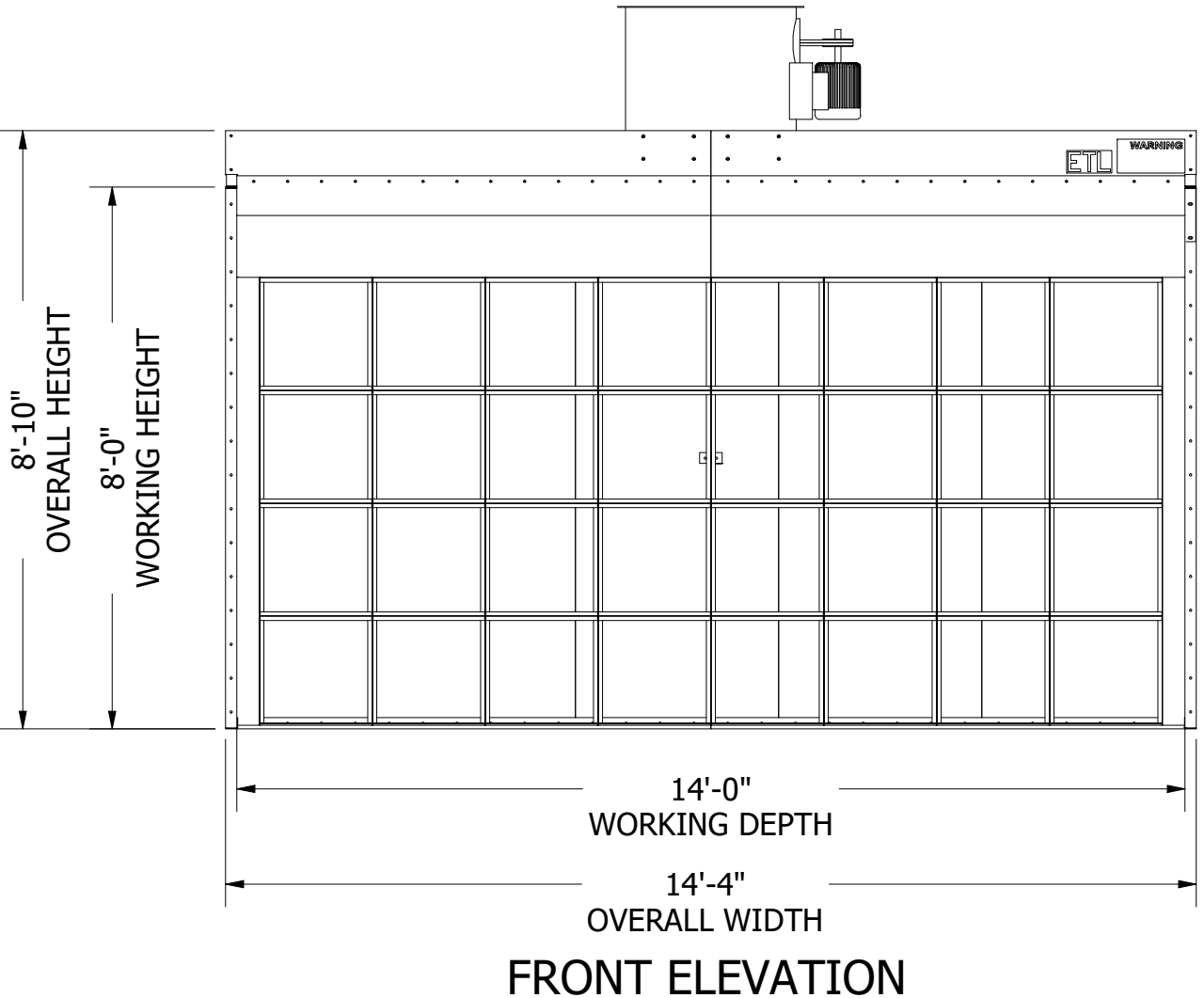

FRONT ELEVATION

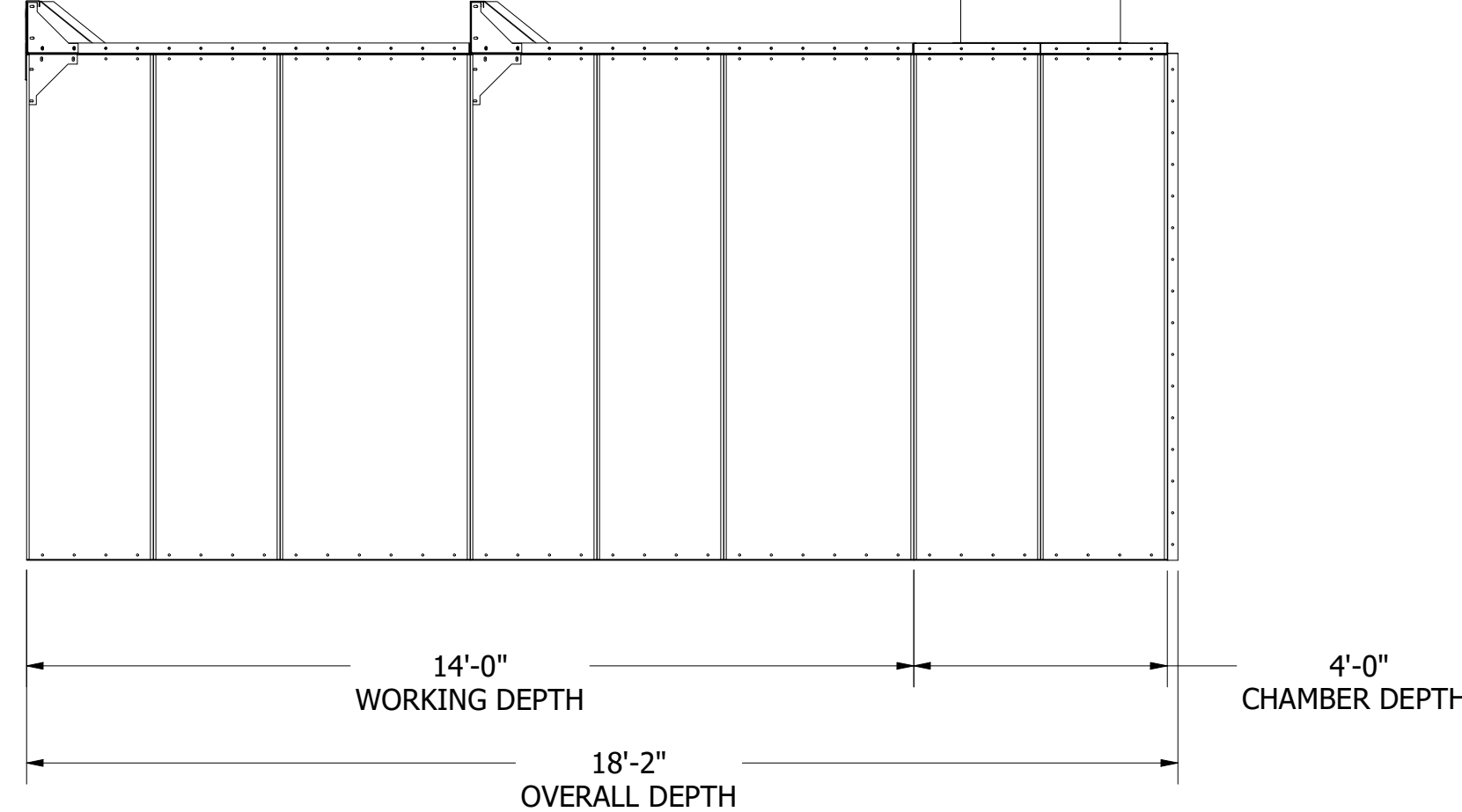

SIDE ELEVATION

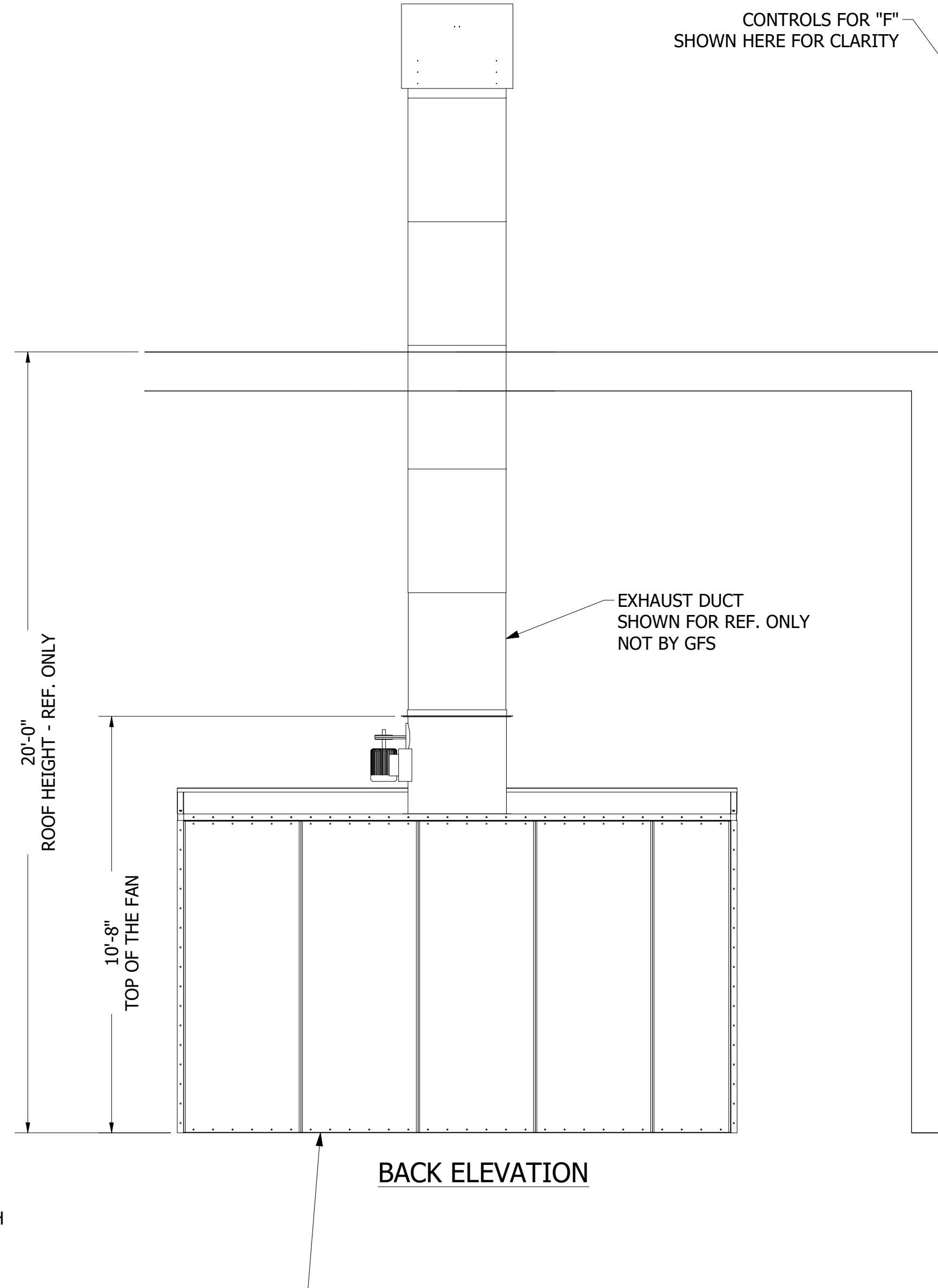

BACK ELEVATION

DUCTWORK SHOWN IS FOR REPRESENTATION ONLY. DUCTWORK CAN BE PURCHASED AS ADDITIONAL EQUIPMENT FROM GFS.

See AFS drawings. Job #756S

**BOOTH EQUIPMENT SPECIFICATIONS**

EXHAUST FAN	
PART #	FAN-30VP-050T3T
DIAMETER	30
TOTAL CFM	11200
STATIC PRESSURE	1
HORSEPOWER	5
VOLTAGE	460
PHASE	3
ENCLOSURE	TEFC
QUANTITY	1
LIGHTS	
PART #	LABW12-4-LED
SIZE	48
TUBES - INCLUDED	4
TYPE	LED
VOLTAGE	120/277
RATING	CLASS 1 DIV. 2
ACCESS	INSIDE
QUANTITY	8
INTAKE FILTERS	
PART #	NA
SIZE	NA
QUANTITY	NA
EXHAUST FILTERS	
PART #	FIL-EPP-2020-W
SIZE	20X20X2
QUANTITY	32
FRONT DOOR	
SIZE	NA
TYPE	NA
STYLE	NA
REAR DOOR	
SIZE	NA
TYPE	NA
STYLE	NA
PERSONNEL DOOR	
SIZE	NA
TYPE	NA
QUANTITY	NA
ELECTRICAL INFO	
OPERATING VOLTAGE	480 VOLT 3PH 4W 60HZ
FULL LOAD AMPS	55
LARGEST MOTOR HP	20
TOTAL HP	35
LIGHTING VOLTAGE	277
68 AMP MIN SERVICE REQ	

**GLOBAL FINISHING SOLUTIONS**  
 12731 NORWAY ROAD  
 OSSEO, WI 54758 USA  
 800-848-8738  
 globalfinishing.com

IMPORTANT NOTE: This print and all information contained therein is the sole property of Global Finishing Solutions, LLC ("GFS"). It is not to be used or reproduced in any manner or submitted to other parties for examination without the express written approval of GFS pursuant to a fully-executed contract or purchase order for GFS-manufactured equipment. Customer may make and retain copies of this print for informational purposes only. GFS does not warrant the accuracy of the information contained herein. GFS is not liable for any damages, including consequential damages, arising from the use of this print on any other project. Any use without written verification is at Customer's sole risk and without liability to GFS, its affiliates, or agents. © Global Finishing Solutions, LLC 2025



SCALE	3/8" = 1'-0"
DRAWN BY	TL
DATE	7/28/2025
REVIEW BY	CRM
REVIEW DATE	7/31/2025

MODEL INFO	DFOCG-140814-NSB
	DRY FILTER BOOTH, 14' W x 8' H x 14' L, GALV.
SHIP TO	CODEL DOOR 1601 INDUSTRIAL WAY PUYALLUP, WA 98371
SOLD TO	ADVANCED FINISHING SYSTEMS INC. 7515 NE 33RD DRIVE PORTLAND, OR 97211
ORDER/SERIAL NUMBER	U178152-B

DRAWING SET	REVISION
R01	2
DRAWING	03

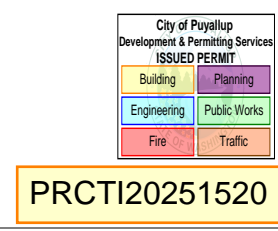

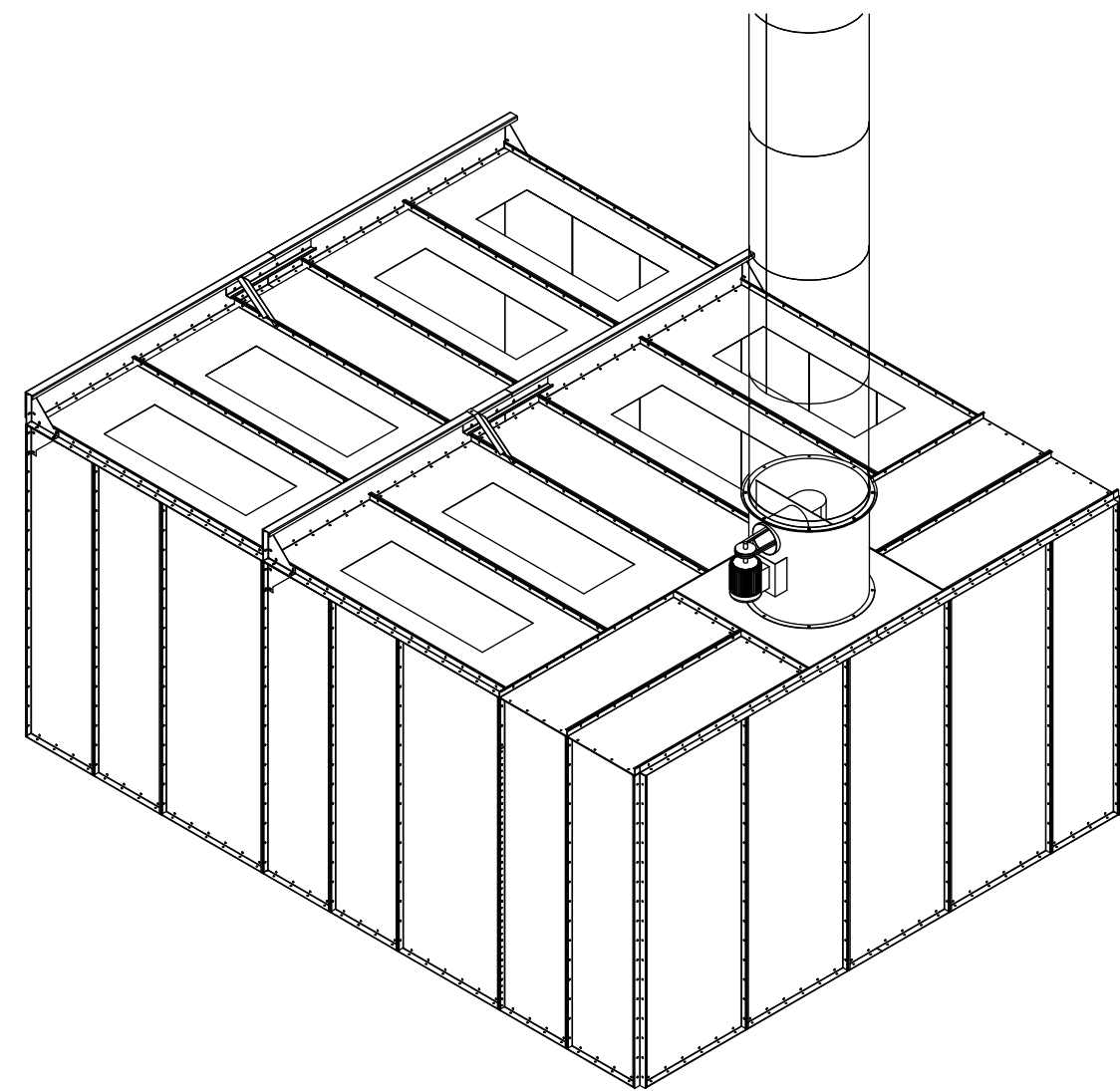
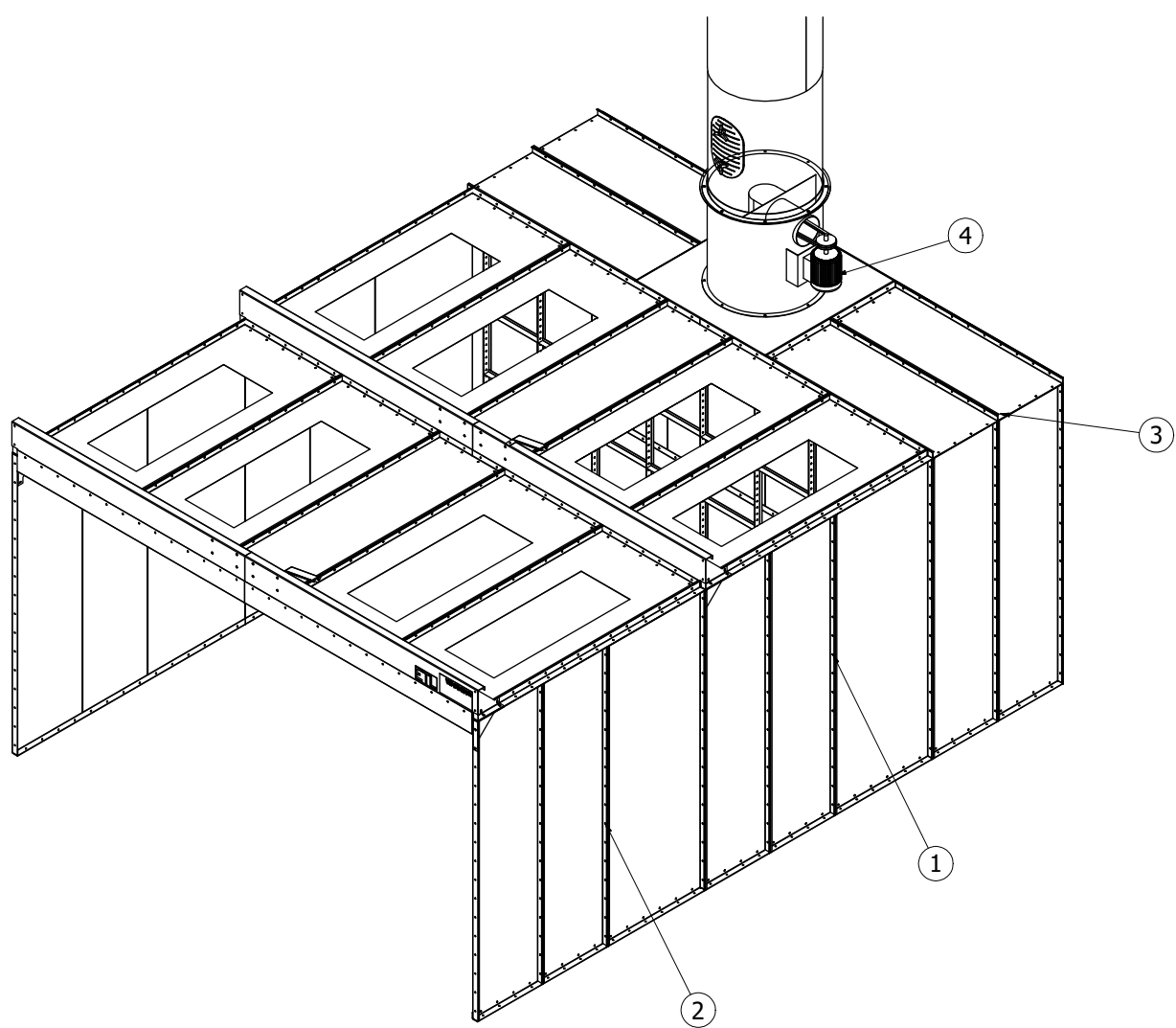

SKID	ITEM	QTY	PART NUMBER	NEW PART NUMBER	DESCRIPTION	MATERIAL	LBS. EACH
	1	1	CA-BAY-01	CA-BAY-01	BAY ASSEMBLY		587
	2	1	CA-BAY-02	CA-BAY-02	BAY ASSEMBLY		600
	3	1	CA-EX-01	CA-EX-01	EXHAUST CHAMBER ASSEMBLY		827
C6	4	1	FAN-30VP-050T3T	1008284	FAN   VP   30.000 DIA   5 HP   208-230/460V   3PH   TEFC	-	225

**GLOBAL FINISHING SOLUTIONS**  
 12731 NORWAY ROAD  
 OSSEO, WI 54758 USA  
 800-848-8738    [globalfinishing.com](http://globalfinishing.com)

IMPORTANT NOTE: This print and all information contained therein is the sole property of Global Finishing Solutions, LLC ("GFS"). It is not to be used or reproduced in any manner or submitted to other parties for examination without the express written approval of GFS pursuant to a fully-executed contract or purchase order for GFS-manufactured equipment. Customer may make and retain copies of the print for information and reference in connection with an equipment order; however, this print is not intended or represented to be suitable for re-use by Customer or third parties or as a basis for any other project. Any use without written approval of GFS is prohibited. Without liability to GFS, its affiliates, or agents.  
 © Global Finishing Solutions, LLC 2025

SCALE	1/2" = 1'-0"
DRAWN BY	TL
DATE	7/28/2025
REVIEW BY	CRM
REVIEW DATE	7/31/2025

SHIP TO  
 CODEL DOOR  
 1601 INDUSTRIAL WAY  
 PUYALLUP, WA 98371

SOLD TO  
 ADVANCED FINISHING SYSTEMS INC.  
 7515 NE 33RD DRIVE  
 PORTLAND, OR 97211

MODEL INFO  
 U178152-B-R01  
 OVERALL ASSEMBLY

ORDER/SERIAL NUMBER	U178152-B
DRAWING SET	R01
REVISION	0

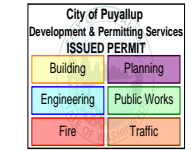

**PRCT120251520**

DRAWING 04

- NOTE:
1. USE  $\varnothing 5/16"$  x  $3/4"$  BOLTS & NUTS FOR ALL TIE ANGLE AND PANEL CONNECTIONS.
  2. USE ONE  $\varnothing 5/16"$  x  $1/2"$  BOLT & NUT EVERY 6 INCHES FOR FILTER RACK TO FILTER RACK CONNECTIONS.
  3. USE ONE  $\varnothing 5/16"$  x  $3/4"$  BOLT & NUT EVERY 6 INCHES FOR FILTER RACK TO PANEL CONNECTIONS WITH THE BOLT HEAD ON THE INSIDE OF THE FILTER CELL.
  4. SEE GSN DRAWING FOR PANEL ANCHORING DETAILS

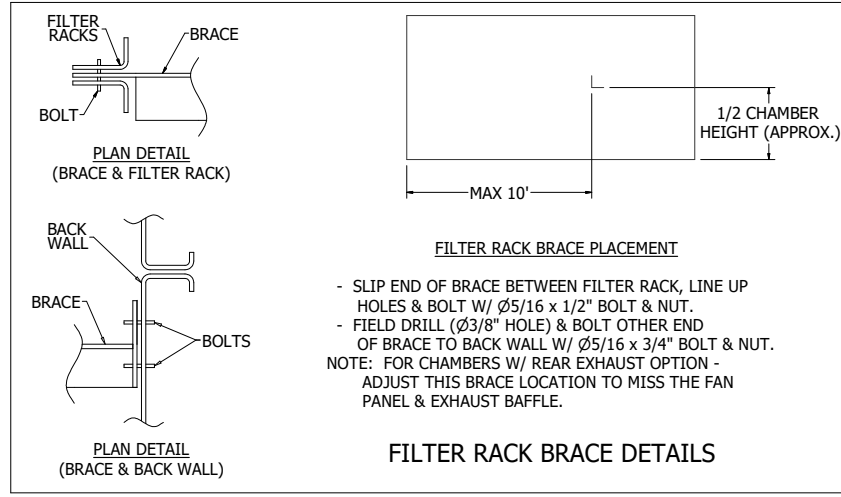

SKID	ITEM	QTY	PART NUMBER	NEW PART NUMBER	DESCRIPTION	MATERIAL	LBS. EACH
C5	5	4	1000594	1000594	TIE ANGLE   14 GA   2.000 X 2.000 X 48.000   3.000 HOE	14 GA	4
C5	6	4	1000607	1000607	TIE ANGLE   14 GA   2.000 X 2.000 X 84.000   3.000 HOE	14 GA	7
C5	7	2	1000610	1000610	TIE ANGLE   14 GA   2.000 X 2.000 X 96.000   3.000 HOE	14 GA	8
C4	8	4	1005494	1005494	PANEL   H   18 GA   36.000 X 95.625 X 2.000	18 GA	53
C2	9	4	1005623	1005623	PANEL   H   18 GA   24.000 X 61.625 X 2.000	18 GA	24
C2	10	5	1005648	1005648	PANEL   H   18 GA   24.000 X 95.625 X 2.000	18 GA	37
C7	11	1	1007893	1007893	FILTER RACK BRACE   18 GA   48.000	18 GA	3
C7	12	2	1023556	1023556	FLOOR CHANNEL   18 GA   2.313 X 84.000	18 GA	4
C7	13	2	1057164	1057164	TIE ANGLE   10 GA   2.000 X 2.000 X 48.000   3.000 HOE	10 GA	7
C7	14	2	1058054	1058054	TIE ANGLE   10 GA   2.000 X 2.000 X 84.000   3.000 HOE	10 GA	12
C7	15	1	1058119	1058119	PANEL   D   FAN   10 GA   48.000 X 48.000 X 2.000	10 GA	77
C7	16	2	1058651	1058651	PANEL   J   18 GA   5.813 X 80.000 X 2.000	18 GA	9
C7	17	1	1058698	1058698	PANEL   L-R   18 GA   17.813 X 85.813 X 2.000	18 GA	24
C7	18	1	1060993	1060993	PANEL   L-L   18 GA   17.813 X 85.813 X 2.000	18 GA	24
C3	19	8	FRAG8-E2-20080	1007953	FILTER RACK, EXHAUST, 20 x 80 x 2		10

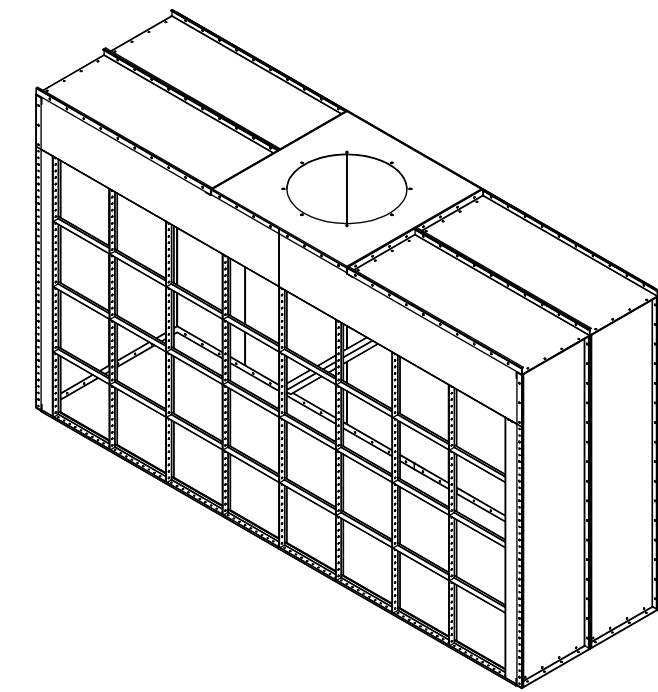
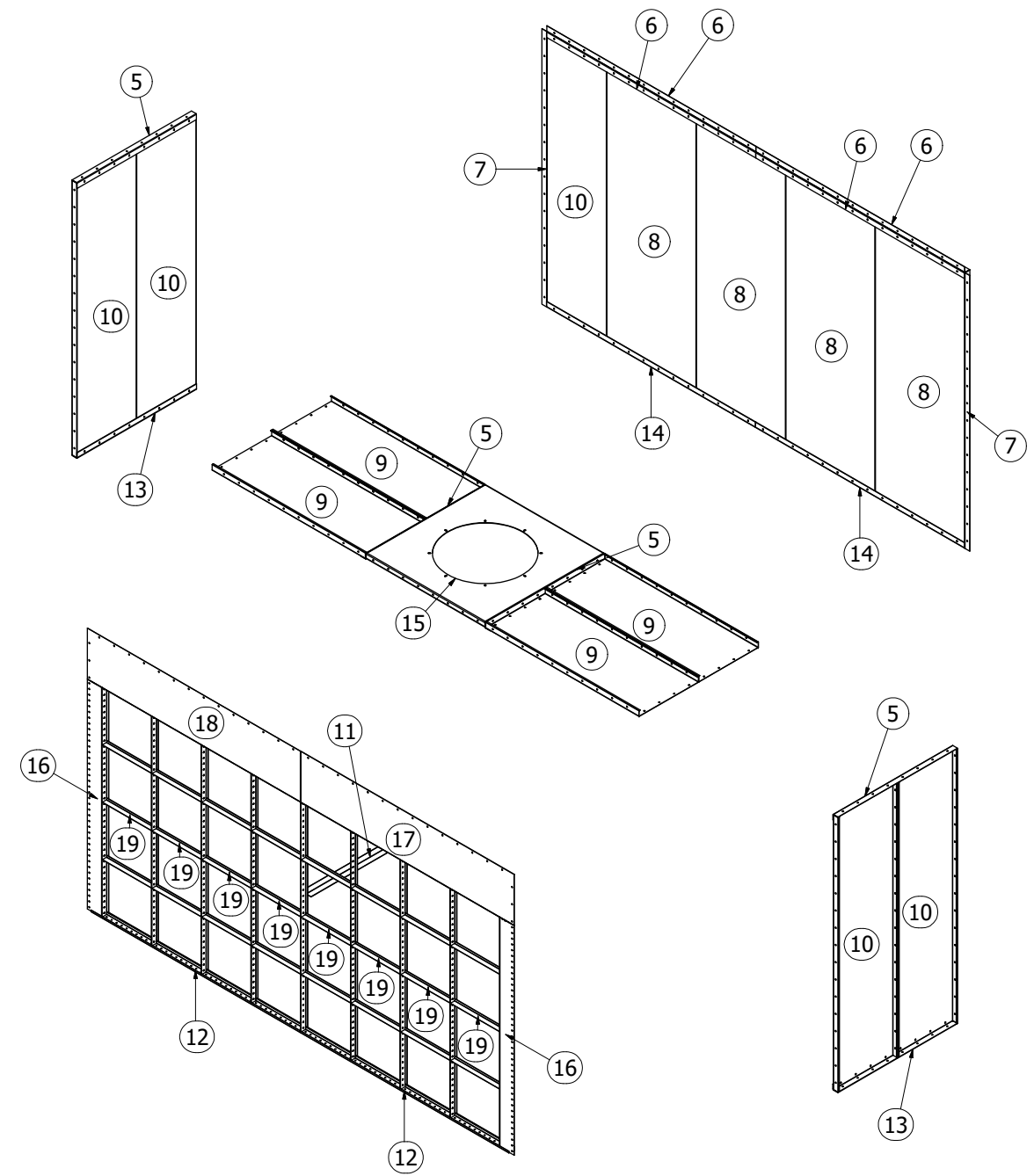

**GLOBAL FINISHING SOLUTIONS**  
 12731 NORWAY ROAD  
 OSSEO, WI 54758 USA  
 800-848-8738  
 globalfinishing.com

IMPORTANT NOTE: This print and all information contained therein is the sole property of Global Finishing Solutions, LLC ("GFS"). It is not to be used or reproduced in any manner or submitted to other parties for examination without the express written approval of GFS pursuant to a fully-executed contract or purchase order for GFS-manufactured equipment. Customer may make and retain copies of the print for information and reference in connection with an equipment order; however, this print is not intended or represented to be suitable for re-use by customer or others on any other project, in any other project, or on any other project. Any use without written permission of GFS is prohibited. Without liability to GFS, its affiliates, or agents.  
 © Global Finishing Solutions, LLC 2025

SCALE	1/2" = 1'-0"
DRAWN BY	TL
DATE	7/28/2025
REVIEW BY	CRM
REVIEW DATE	7/31/2025

MODEL INFO	CA-EX-01	SHIP TO	CODEL DOOR 1601 INDUSTRIAL WAY PUYALLUP, WA 98371
ORDER/SERIAL NUMBER	U178152-B	SOLD TO	ADVANCED FINISHING SYSTEMS INC. 7515 NE 33RD DRIVE PORTLAND, OR 97211
DRAWING SET	R01	REVISION	0
DRAWING	05		

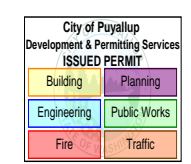

PRCT120251520

- NOTE:
1. USE  $\frac{1}{2}$ " x 1" BOLTS & NUTS FOR PLATE TO FRAME MEMBER CONNECTIONS.
  2. USE  $\frac{5}{16}$ " x  $\frac{3}{4}$ " BOLTS & NUTS FOR ALL OTHER TIE ANGLE, PANEL AND FRAME MEMBER CONNECTIONS.
  3. FRAME BRACE MUST BE LOCATED WITHIN THREE FEET OF BOOTH'S CENTER BETWEEN PANEL FLANGES.
  4. FIELD DRILL (1)  $\frac{3}{8}$ " HOLE THRU TOP STRUCTURAL MEMBERS AND USE  $\frac{5}{16}$ " x 1" BOLT & NUT TO SECURE FRAME BRACE TO STRUCTURE.
  5. SEE GSN DRAWING FOR PANEL ANCHORING DETAILS

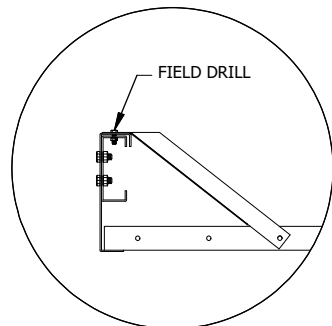

**FRAME BRACE DETAIL**  
FRAME BRACE MUST BE PLACED BETWEEN PANEL FLANGES WITHIN THREE FEET OF BAY CENTER.

SKID	ITEM	QTY	PART NUMBER	NEW PART NUMBER	DESCRIPTION	MATERIAL	LBS. EACH
C5	6	6	1000607	1000607	TIE ANGLE   14 GA   2.000 X 2.000 X 84.000   3.000 HOE	14 GA	7
C4	8	2	1005494	1005494	PANEL   H   18 GA   36.000 X 95.625 X 2.000	18 GA	53
C2	10	4	1005648	1005648	PANEL   H   18 GA   24.000 X 95.625 X 2.000	18 GA	37
C7	14	2	1058054	1058054	TIE ANGLE   10 GA   2.000 X 2.000 X 84.000   3.000 HOE	10 GA	12
C7	20	1	1001456	1001456	FRAME BRACE   18 GA   15.688	18 GA	1
C7	21	1	1001493	1001493	SPLICE PLATE   10 GA   5.500 X 30.000	10 GA	11
C7	22	4	1001495	1001495	CORNER BRACE   12 GA   9.625 X 9.625	12 GA	0
C7	23	1	1001518	1001518	FRAME MEMBER   L   12 GA   10.000 X 86.000 X 2.625	12 GA	39
C7	24	1	1001519	1001519	FRAME MEMBER   R   12 GA   10.000 X 86.000 X 2.625	12 GA	39
C2	25	1	1005639	1005639	PANEL   H   18 GA   24.000 X 83.625 X 2.000	18 GA	33
C4	26	4	1005836	1005836	PANEL   H   LIGHT   18 GA   36.000 X 83.625 X 2.000	18 GA	34

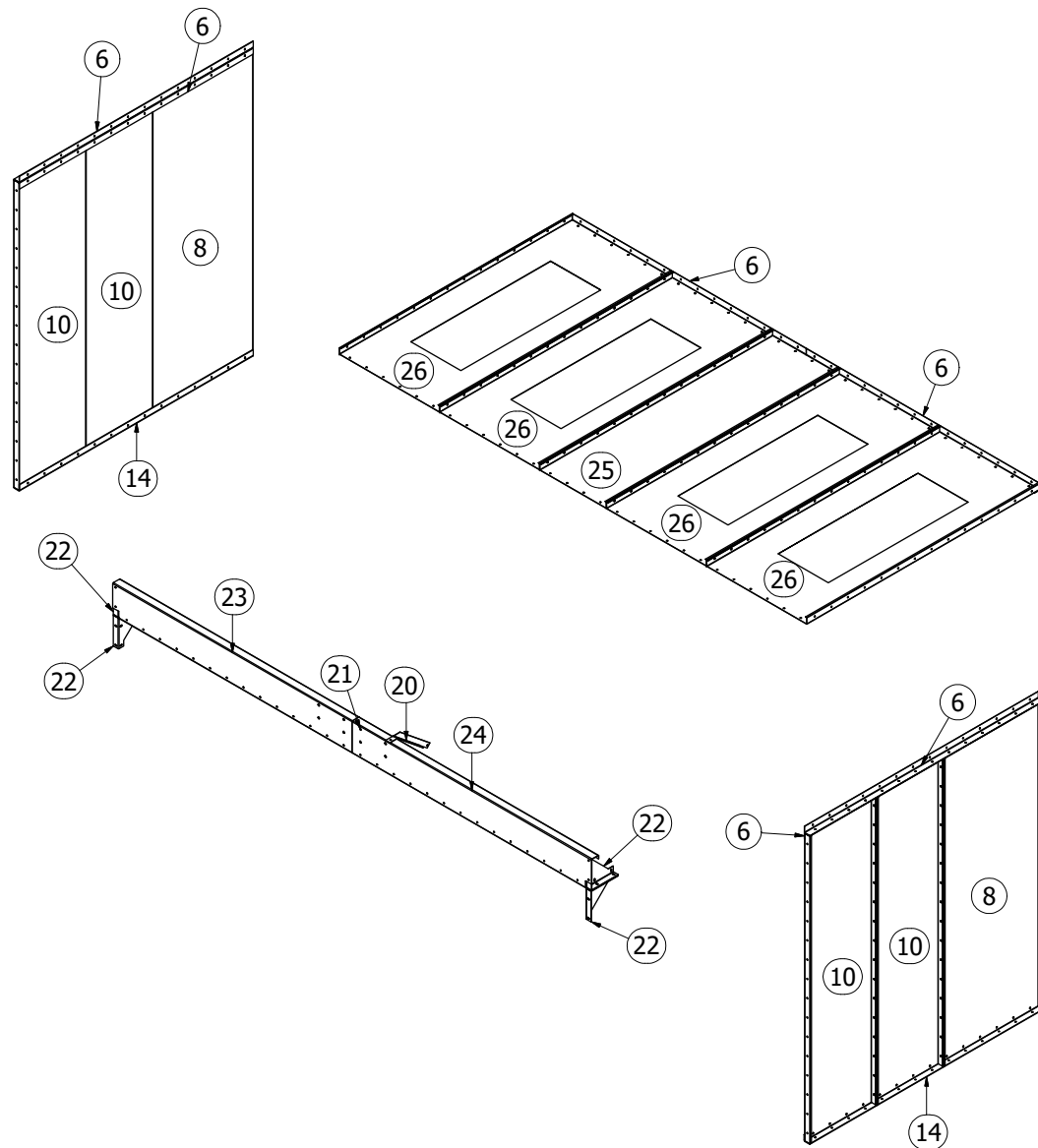
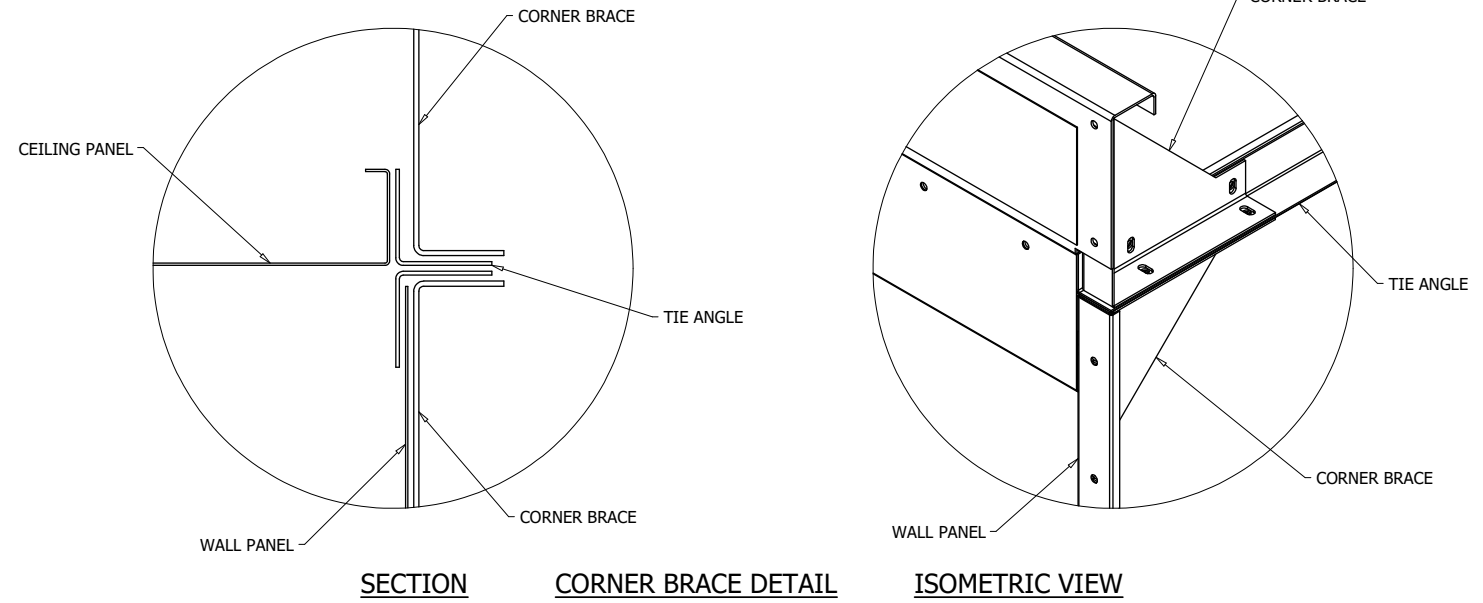

\*\* ASSEMBLE FRAMES, SPLICE PLATE, AND CORNER PLATES ON THE GROUND. LIFT INTO POSITION AND BOLT TO CEILING AND WALL PANELS.

**GLOBAL FINISHING SOLUTIONS**  
12731 NORWAY ROAD  
OSSEO, WI 54758 USA  
800-848-8738  
globalfinishing.com

IMPORTANT NOTE: This print and all information contained therein is the sole property of Global Finishing Solutions, LLC ("GFS"). It is not to be used or reproduced in any manner or submitted to other parties for examination without the express written approval of GFS pursuant to a fully-executed contract or purchase order for GFS-manufactured equipment. Customer may make and retain copies of the print for information and reference in connection with an equipment order; however, this print is not intended or represented to be suitable for re-use by customer or others or extensions of this order on any other project. Any use without written approval of GFS is prohibited. Without liability to GFS, its affiliates, or agents.  
© Global Finishing Solutions, LLC 2025

SCALE	1/2" = 1'-0"
DRAWN BY	TL
DATE	7/28/2025
REVIEW BY	CRM
REVIEW DATE	7/31/2025

MODEL INFO  
CA-BAY-01  
BAY ASSEMBLY

SHIP TO  
CODEL DOOR  
1601 INDUSTRIAL WAY  
PUYALLUP, WA 98371

SOLD TO  
ADVANCED FINISHING SYSTEMS INC.  
7515 NE 33RD DRIVE  
PORTLAND, OR 97211

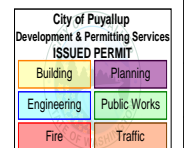

PRCTI20251520

ORDER/SERIAL NUMBER	U178152-B
DRAWING SET	R01
REVISION	0
DRAWING	06

- NOTE:
1. USE  $\frac{1}{2}$ " x 1" BOLTS & NUTS FOR PLATE TO FRAME MEMBER CONNECTIONS.
  2. USE  $\frac{5}{16}$ " x  $\frac{3}{4}$ " BOLTS & NUTS FOR ALL OTHER TIE ANGLE, PANEL AND FRAME MEMBER CONNECTIONS.
  3. FRAME BRACE MUST BE LOCATED WITHIN THREE FEET OF BOOTH'S CENTER BETWEEN PANEL FLANGES.
  4. FIELD DRILL (1)  $\frac{3}{8}$ " HOLE THRU TOP STRUCTURAL MEMBERS AND USE  $\frac{5}{16}$ " x 1" BOLT & NUT TO SECURE FRAME BRACE TO STRUCTURE.
  5. SEE GSN DRAWING FOR PANEL ANCHORING DETAILS

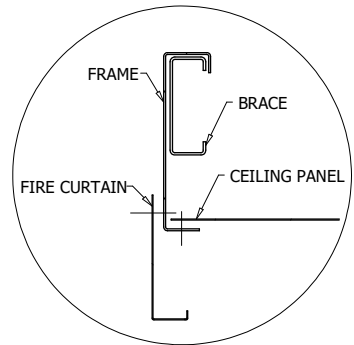

**FIRE CURTAIN DETAIL**

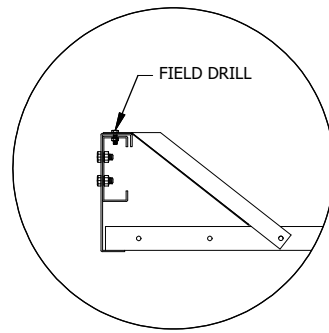

**FRAME BRACE DETAIL**  
FRAME BRACE MUST BE PLACED BETWEEN PANEL FLANGES WITHIN THREE FEET OF BAY CENTER.

SKID	ITEM	QTY	PART NUMBER	NEW PART NUMBER	DESCRIPTION	MATERIAL	LBS. EACH
C5	6	6	1000607	1000607	TIE ANGLE   14 GA   2.000 X 2.000 X 84.000   3.000 HOE	14 GA	7
C4	8	2	1005494	1005494	PANEL   H   18 GA   36.000 X 95.625 X 2.000	18 GA	53
C2	10	4	1005648	1005648	PANEL   H   18 GA   24.000 X 95.625 X 2.000	18 GA	37
C7	14	2	1058054	1058054	TIE ANGLE   10 GA   2.000 X 2.000 X 84.000   3.000 HOE	10 GA	12
C7	20	1	1001456	1001456	FRAME BRACE   18 GA   15.688	18 GA	1
C7	21	1	1001493	1001493	SPLICE PLATE   10 GA   5.500 X 30.000	10 GA	11
C7	22	4	1001495	1001495	CORNER BRACE   12 GA   9.625 X 9.625	12 GA	2
C7	23	1	1001518	1001518	FRAME MEMBER   L   12 GA   10.000 X 86.000 X 2.625	12 GA	39
C2	25	1	1005639	1005639	PANEL   H   18 GA   24.000 X 83.625 X 2.000	18 GA	33
C4	26	4	1005836	1005836	PANEL   H   LIGHT   18 GA   36.000 X 83.625 X 2.000	18 GA	34
C7	27	2	1008134	1008134	FIRE CURTAIN   J   18 GA   7.000 X 84.000 X 2.000	18 GA	11
C7	28	1	1058695	1058695	FRAME MEMBER   ETL/WARN LABEL OUT   10.000 X 86.000		39

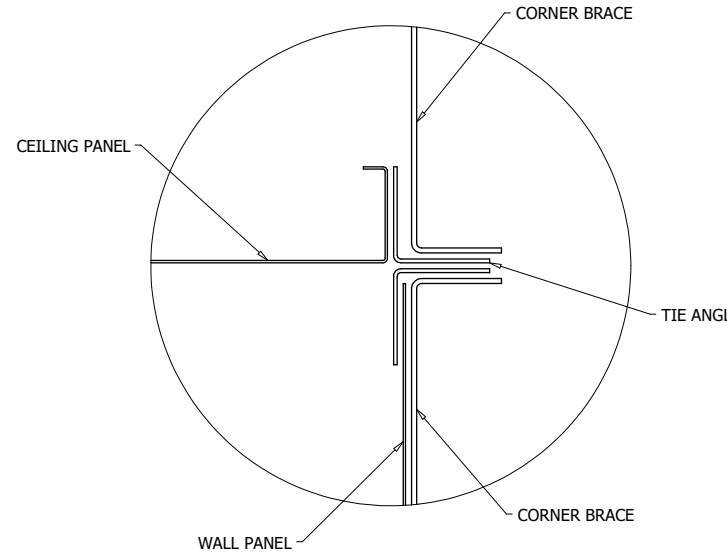

**SECTION**

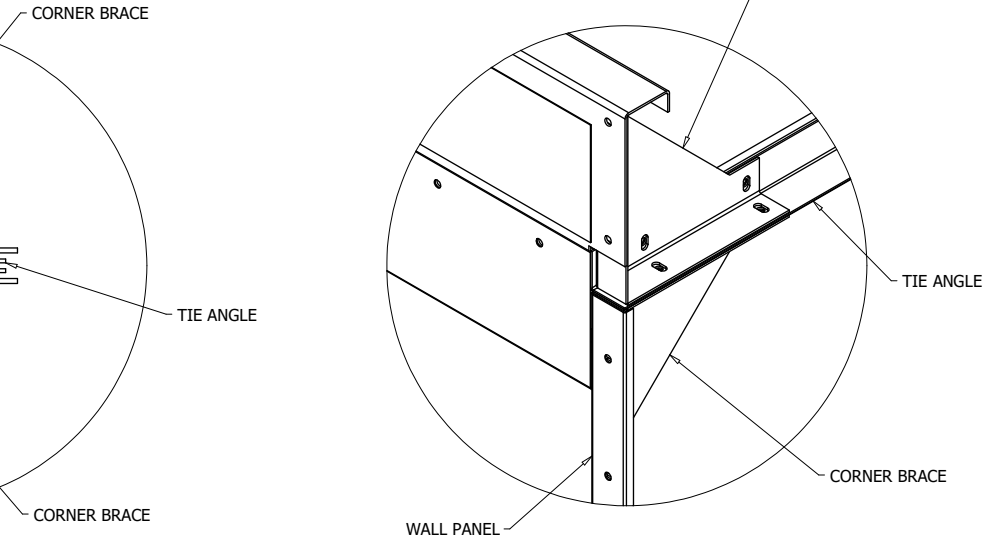

**CORNER BRACE DETAIL**

**ISOMETRIC VIEW**

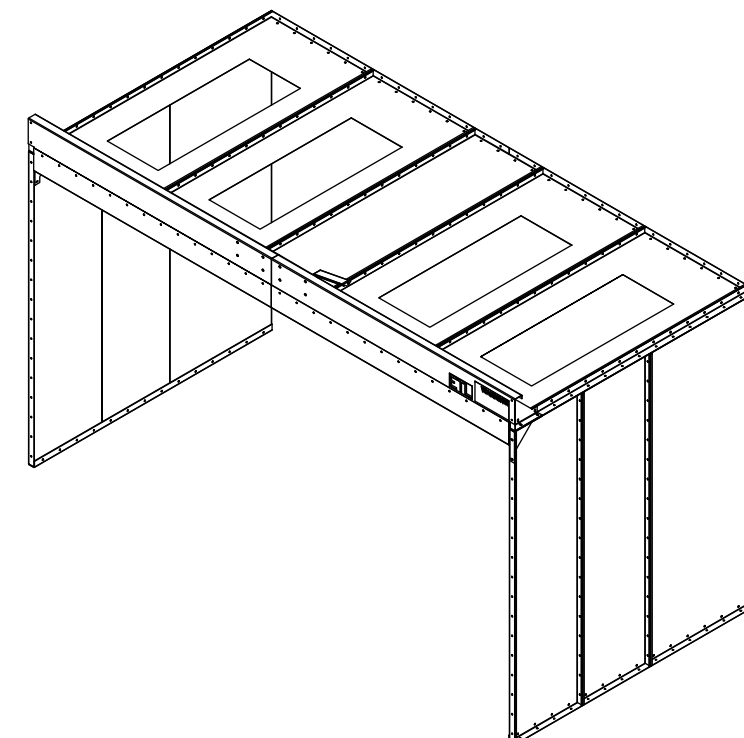
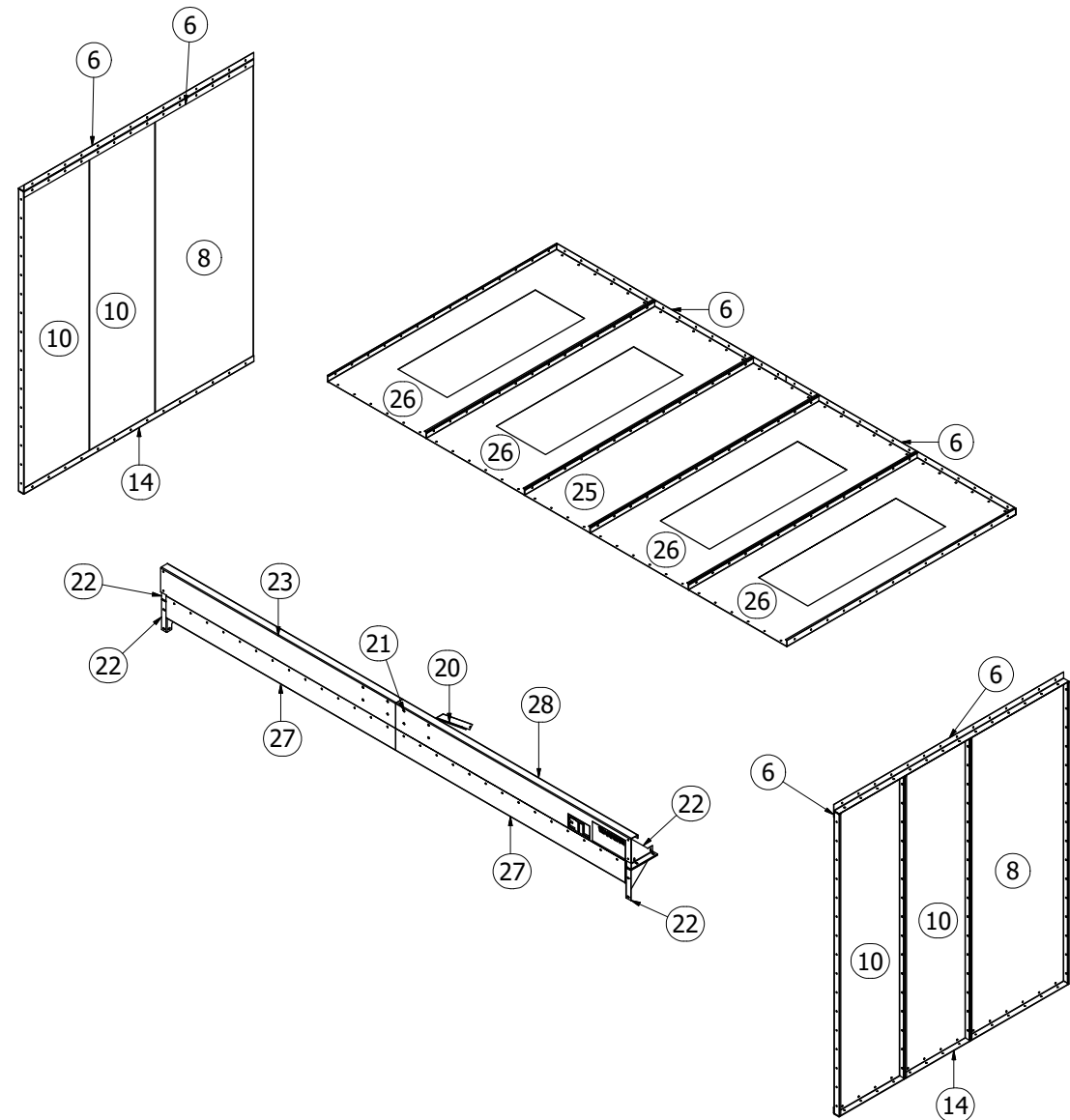

\*\* ASSEMBLE FRAMES, SPLICE PLATE, AND CORNER PLATES ON THE GROUND. LIFT INTO POSITION AND BOLT TO CEILING AND WALL PANELS.

**GLOBAL FINISHING SOLUTIONS**  
12731 NORWAY ROAD  
OSSEO, WI 54758 USA  
800-848-8738  
globalfinishing.com

IMPORTANT NOTE: This print and all information contained therein is the sole property of Global Finishing Solutions, LLC ("GFS"). It is not to be used or reproduced in any manner or submitted to other parties for examination without the express written approval of GFS pursuant to a fully-executed contract or purchase order for GFS-manufactured equipment. Customer may make and retain copies of the print for information and reference in connection with an equipment order; however, this print is not intended or represented to be suitable for re-use by customer or third parties in any other project. Any use without written permission of GFS is prohibited. Without liability to GFS, its affiliates, or agents.  
© Global Finishing Solutions, LLC 2025

SCALE	1/2" = 1'-0"
DRAWN BY	TL
DATE	7/28/2025
REVIEW BY	CRM
REVIEW DATE	7/31/2025

MODEL INFO	CA-BAY-02 BAY ASSEMBLY	SHIP TO	CODEL DOOR 1601 INDUSTRIAL WAY PUYALLUP, WA 98371
SOLD TO	ADVANCED FINISHING SYSTEMS INC. 7515 NE 33RD DRIVE PORTLAND, OR 97211	ORDER/SERIAL NUMBER	U178152-B
DRAWING SET	R01	REVISION	0
DRAWING	07		

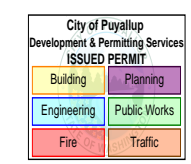

**PRCT120251520**