



**SITE STRUCTURES**  
A Division of Kosnik Engineering, PC

PRRWF20260365

# Normandy Heights Storm Water Detention Vault

Puyallup, Washington

*Structural Calculations*

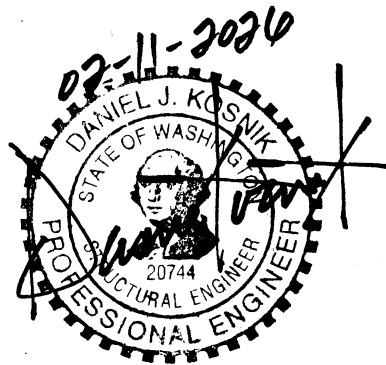

City of Puyallup  
Building  
REVIEWED  
FOR  
COMPLIANCE

SKinnear  
03/26/2026  
10:11:01 AM



Project No. S-26-009

First Issue 02-11-2026

Calculations required to be provided by  
the Permittee on site for all inspections

*Normandy Heights  
Storm Water Detention Vault*

*Project No. S-26-009*

**STRUCTURAL CALCULATIONS INDEX**

---

	<u>Sheet</u>
Design Criteria	01 - 05
Lid Review	06 - 09
Wall & Footing Review	10 - 35
Framing at Grated Opening	36 - 45
Lateral Stability Review	46 - 50

SHEET 1  
12-11-26  
9-26-09

**Normandy Heights**  
**Storm Water Detention Vault**

**DESIGN CRITERIA**

Code: 2021 IBC

Permitting: City of Puyallup, Washington

Soil Cover: 1.5ft typ over the entire vault rising to 4.5ft at the western end of the vault below the access road

Lid Loading: 150psf uniform live load  
HS-20 truck wheel loading

Design uniform live load & truck wheel loads to be applied independently and in combination with the soil cover dead load.

Raised Grated Opening: 100psf uniform pedestrian live load.

**Foundation Design:**

Foundation design is based on the following values provided by the Earth Solutions NW in their geotechnical report updated 11-09-2009, updated 05-03-2022 and e-mail correspondence of 02-06-2026.

Allowable Bearing Pressure: 3,500 psf on select fill

Lateral Earth Pressures on Vault Walls ( drained backfill condition ):

At Rest condition: 55pcf EFD level backfill  
84pcf EFD upward sloped backfill

Seismic Addition: E = 8Hpsf uniform horz pressure

Traffic surcharge: 70psf uniform horz pressure

Design short period spectral response acceleration  $S_d=0.833$

Saturated Soil Density: 125pcf

**Material Requirements:**

Rebar: Grade 60

Concrete:  $f'_c=4000$  psi walls, footings and grade slab and CIP lid sections  
 $f'_c=3000$  psi plank void fill and closure

Lid: Pre-cast, Pre-stressed Hollow Core Plank 12-1/2" thick.

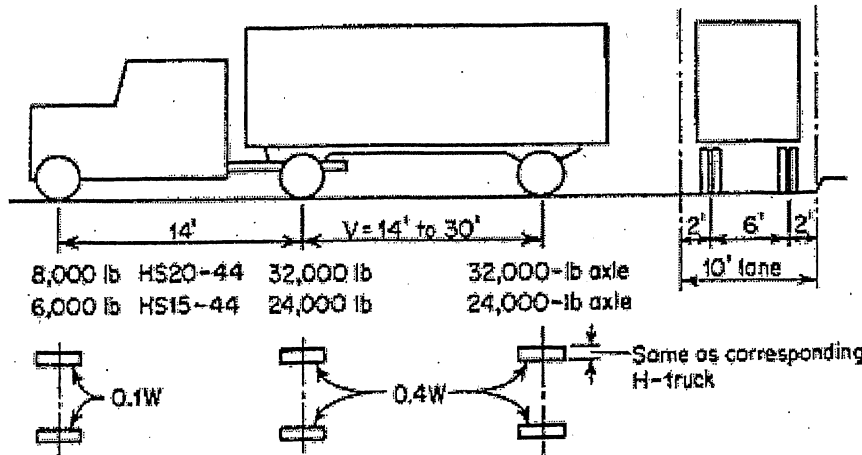
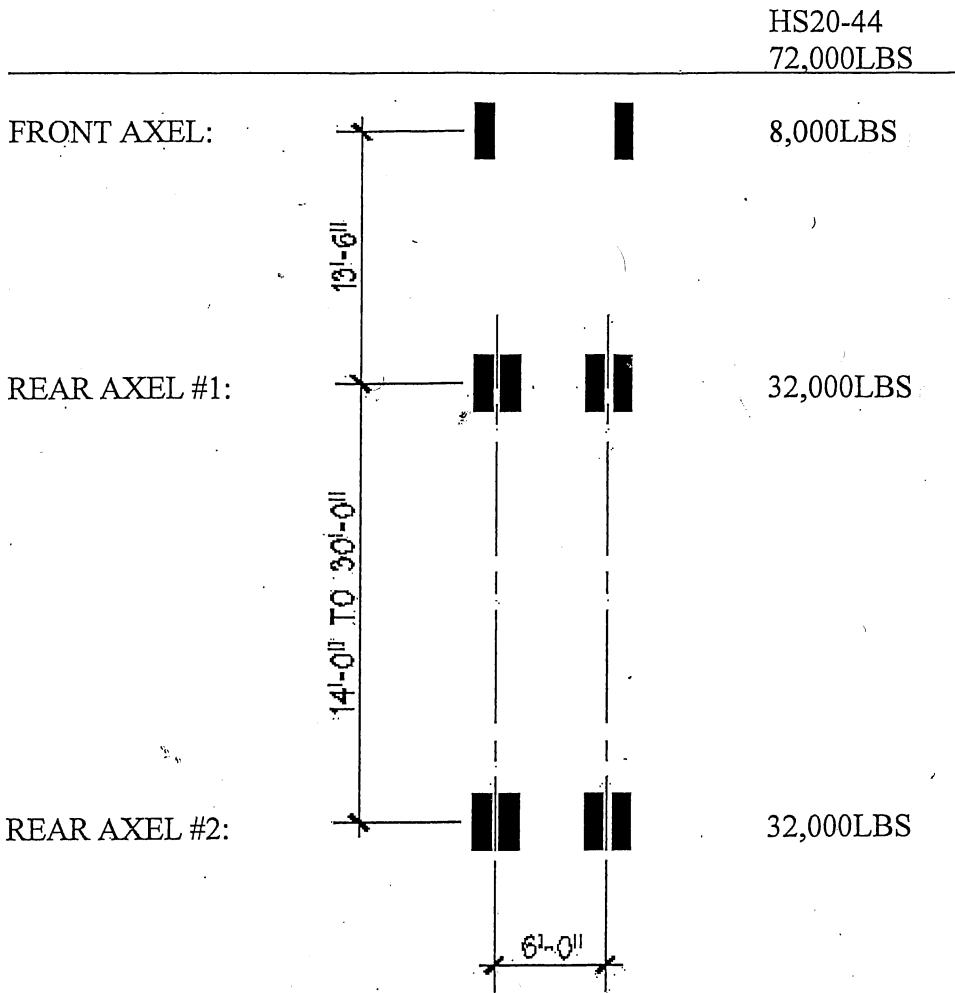

W = combined weight of first two axles  
 V = variable, use spacing which produces maximum stress  
 For design of slabs, centerline of wheel to be 1 ft from curb

**Dan Kosnik**

SHEET 3  
02-11-24  
S-26-009

**From:** Chase Halsen <chaseh@esnw.com>  
**Sent:** Friday, February 6, 2026 9:41 AM  
**To:** James Kerby; Dan Kosnik  
**Cc:** Cara Visintainer  
**Subject:** RE: Normandy Hgts

Hi Dan,

Responses below.

We are working on the vault struct design- see attachment - and need some input on geotechnical design criteria as follows:

- Can we use an allowable bearing pressure greater than the 2500psf mentioned in you report when designing the vault wall footings.
  - We can use an increased bearing capacity of 3,500 psf if we support the vault footings on at least 2 feet of select fill. James, if we go this route, the select fill will need to extend two feet on both sides of the footing. We will evaluate if fabric is needed based on what we encounter in the field during construction.
- What at rest earth pressure should we use for the upward sloped backfill on the south side of the vault?
  - At rest earth pressure for a 2:1 slope condition above the wall can be assumed at 84 pcf. Since this is a slope of limited height, we can also apply it as a surcharge (rectangular distribution) of 295 psf with an active earth pressure of 59 pcf.
- What passive pressure might be possible for the downward sloped backfill on the north side of the site. The backfill conditions vary with a portion of the wall having a retaining wall 6ft north of the wall.
  - We can assume a passive pressure of 240 pcf. A FOS of 1.5 has already been included in this value.

**Chase Halsen, L.G., L.E.G.**

Earth Solutions NW ● 425-449-4704

This e-mail is intended for the use of the individual to whom it is addressed and may contain information that is privileged, confidential or otherwise exempt from disclosure under applicable law. If the receiver of this e-mail is not the intended recipient or the employee or agent responsible for delivering the message to the intended recipient, you are hereby notified that any dissemination, distribution or copying of this communication is strictly prohibited.

RM Homes, LLC  
November 9, 2006  
Updated May 3, 2022

### Retaining Walls

Retaining walls must be designed to resist earth pressures and applicable surcharge loads. The following parameters may be used for design:

- Active earth pressure (unrestrained condition) 35 pcf (equivalent fluid)
- At-rest earth pressure (restrained condition) 55 pcf
- Traffic surcharge\* (passenger vehicles) 70 psf (rectangular distribution)
- Passive earth pressure 300 pcf (equivalent fluid)
- Allowable soil bearing capacity 2,500 psf
- Coefficient of friction 0.40
- Seismic surcharge 8H psf\*\*

\* Where applicable.

\*\* Where H equals the retained height (in feet).

Additional surcharge loading from foundations, sloped backfill, or other loading should be included in the retaining wall design, as appropriate. Drainage should be provided behind retaining walls such that hydrostatic pressures do not develop. If drainage is not provided, hydrostatic pressures should be included in the wall design, as appropriate. ESNW should review retaining wall designs to verify that appropriate earth pressure values have been incorporated into the design and to provide additional recommendations, as necessary.

**Seismic Design**

The 2018 International Building Code (2018 IBC) recognizes the most recent edition of the Minimum Design Loads for Buildings and Other Structures manual (ASCE 7-16) for seismic design, specifically with respect to earthquake loads. Based on the soil conditions encountered at the test pit locations, the parameters and values provided below are recommended for seismic design per the 2018 IBC.

Parameter	Value
Site Class	D*
Mapped short period spectral response acceleration, $S_s (g)$	1.249
Mapped 1-second period spectral response acceleration, $S_1 (g)$	0.430
Short period site coefficient, $F_a$	1.001
Long period site coefficient, $F_v$	1.870 <sup>†</sup>
Adjusted short period spectral response acceleration, $S_{MS} (g)$	1.249
Adjusted 1-second period spectral response acceleration, $S_{M1} (g)$	0.804 <sup>†</sup>
Design short period spectral response acceleration, $S_{DS} (g)$	0.833
Design 1-second period spectral response acceleration, $S_{D1} (g)$	0.539 <sup>†</sup>

\* Assumes dense native soil conditions, encountered to a maximum depth of 21.5 feet bgs during the February 2022 field exploration, remain at least medium dense to at least 100 feet bgs.

† Values assume  $F_v$  may be determined using linear interpolation per Table 11.4-2 in ASCE 7-16.

As indicated in the table footnote, several of the seismic design values provided above are dependent on the assumption that site-specific ground motion analysis (per Section 11.4.8 of ASCE 7-16) will not be required for the subject project. ESNW recommends the validity of this assumption be confirmed at the earliest available opportunity during the planning and early design stages of the project. Further discussion between the project structural engineer, the project owner, and ESNW may be prudent to determine the possible impacts to the structural design due to increased earthquake load requirements under the 2018 IBC. ESNW can provide additional consulting services to aid with design efforts, including supplementary geotechnical and geophysical investigation, upon request.

Liquefaction is a phenomenon where saturated or loose soil suddenly loses internal strength and behaves as a fluid. This behavior is in response to increased pore water pressures resulting from an earthquake or another intense ground shaking. In our opinion, site susceptibility to liquefaction may be considered low. The depth of the regional groundwater table and the relatively medium dense characteristics of the native soil were the primary bases for this opinion.

**SITE STRUCTURES**

10511 19th Ave SE, Suite C  
Everett, WA, (425)-357-9600

Project Normandy Hgts

sheet 6

date 02-11-20

prj. no. S-26-009

**PRECAST HOLLOW CORE PLANK REVIEW**

**Lid Data**

Soil Density	125 pcf
Soil Cover depth over lid	1.5 ft
Plank design clear span	18.17 ft
Design Uniform Live Load	150 psf
Design Superimposed Load	337.5 psf

**Plank capacity based on uniform superimposed load tables**

Plank span	28 ft	
No of tendons	11	
Allowable superimposed loads		413 psf

Allowable superimposed loads base of design span of	18.42 ft	
Based on flexural capacity		954 psf
Based on shear capacity		628 psf

*ok w/ 2 END  
VOIDS FILLED*

**Plank capacity based on truck load charts**

Plank span	18.42 ft	
No of tendons	11	
Allowable soil cover without knee-walls	0.5 to 3.4 ft	
Allowable soil cover with knee-walls	0.5 to 7.0 ft	

*ok w/o KNEEWALLS  
@ MANHOLES*





12 1/2" HOLLOW CORE SLAB

HS20-44

02-11-26

S-26-009

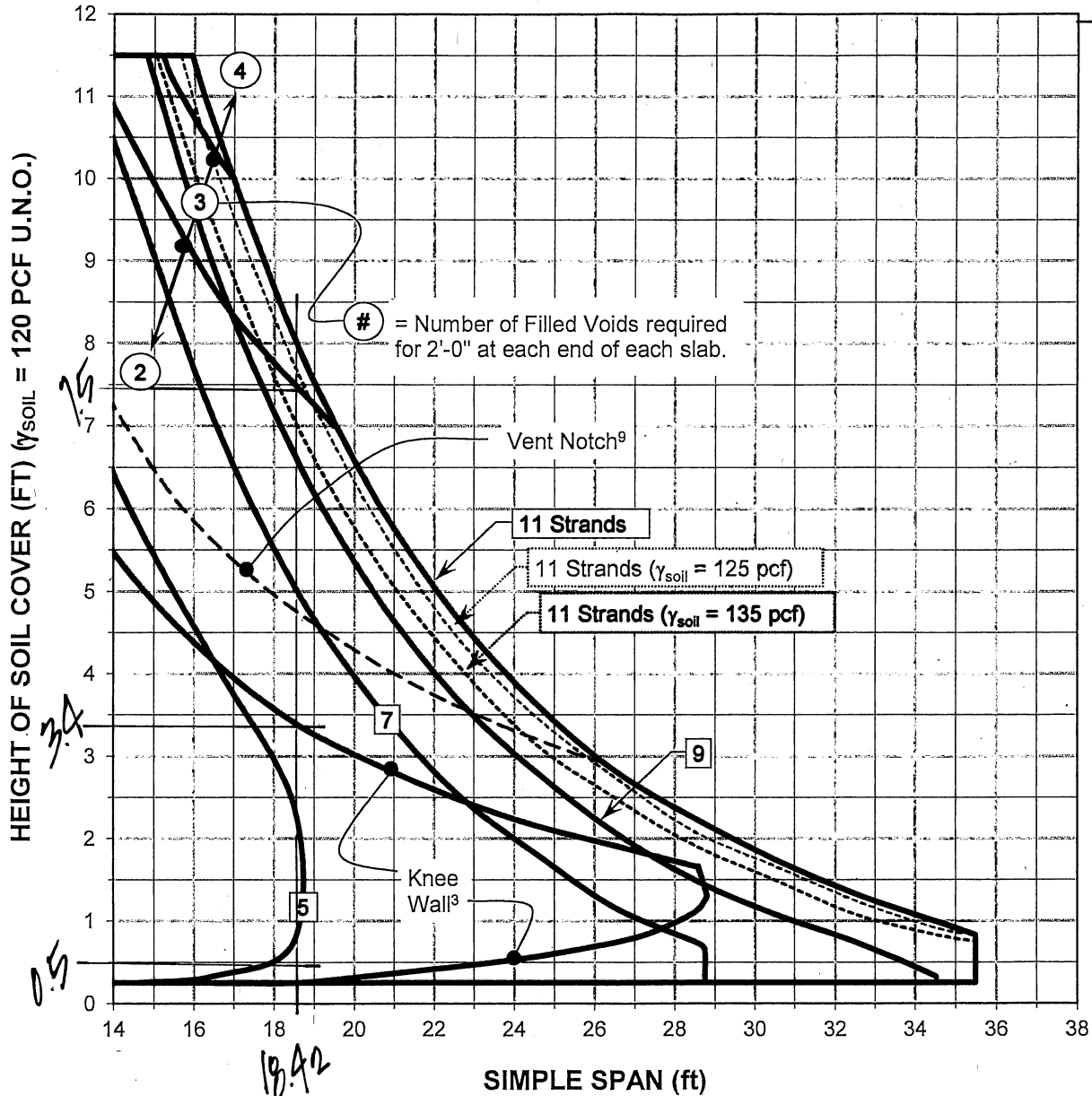

**GENERAL NOTES:**

- 1.) A minimum cover depth of six inches OR a three inch thick cast in place concrete topping slab is required.
- 2.) Simple Span is centerline of bearing to centerline of bearing.
- 3.) The Knee Wall envelope represents the maximum span and height of soil cover that can be supported by slabs with standard notches for manhole openings, assuming void fill concrete  $f'c = 3,000$  psi. Points falling outside this envelope require knee walls to support the slabs at manhole openings.
- 4.) Interpolation between strand contours is acceptable. DO NOT extrapolate beyond the bounds of this chart.
- 5.) Soil cover is assumed to be uniform.
- 6.) Except as noted, soil cover unit weight is assumed to be 120 pcf.
- 7.) Minimum span length = 14'-0".
- 8.) The values shown on this chart are in compliance with IBC 2021 & ACI 318-19.
- 9.) The Vent Notch envelope represents the maximum span and height of soil cover that can be supported by slabs with 6 1/2" standard notches in adjacent slabs to accommodate 12" diameter vents, assuming void fill concrete  $f'c = 3,000$  psi. Refer to Detail 3 on page 13 of this brochure for vent notch details.

12½" HOLLOW CORE SLAB  
150 PSF

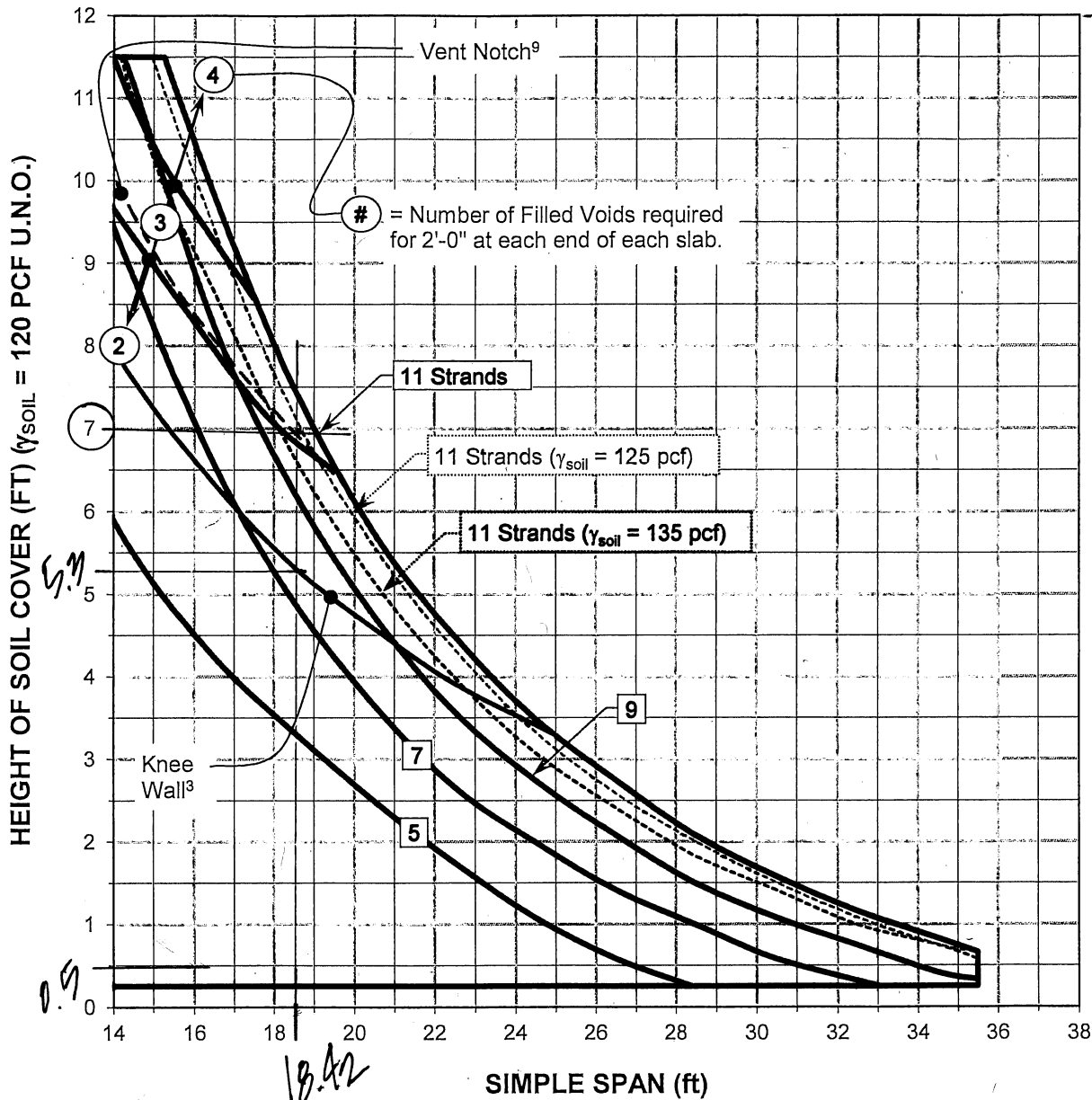

**GENERAL NOTES:**

- 1.) A minimum cover depth of six inches OR a three inch thick cast in place concrete topping slab is required.
- 2.) Simple Span is centerline of bearing to centerline of bearing.
- 3.) The Knee Wall envelope represents the maximum span and height of soil cover that can be supported by slabs with standard notches for manhole openings, assuming void fill concrete f'c = 3,000 psi. Points falling outside this envelope require knee walls to support the slabs at manhole openings.
- 4.) Interpolation between strand contours is acceptable. DO NOT extrapolate beyond the bounds of this chart.
- 5.) Soil cover is assumed to be uniform.
- 6.) Except as noted, soil cover unit weight is assumed to be 120 pcf.
- 7.) Minimum span length = 14'-0".
- 8.) The values shown on this chart are in compliance with IBC 2021 & ACI 318-19.
- 9.) The Vent Notch envelope represents the maximum span and height of soil cover that can be supported by slabs with 6½" standard notches in adjacent slabs to accommodate 12" diameter vents, assuming void fill concrete f'c = 3,000 psi. Refer to Detail 3 on page 13 of this brochure for vent notch details.

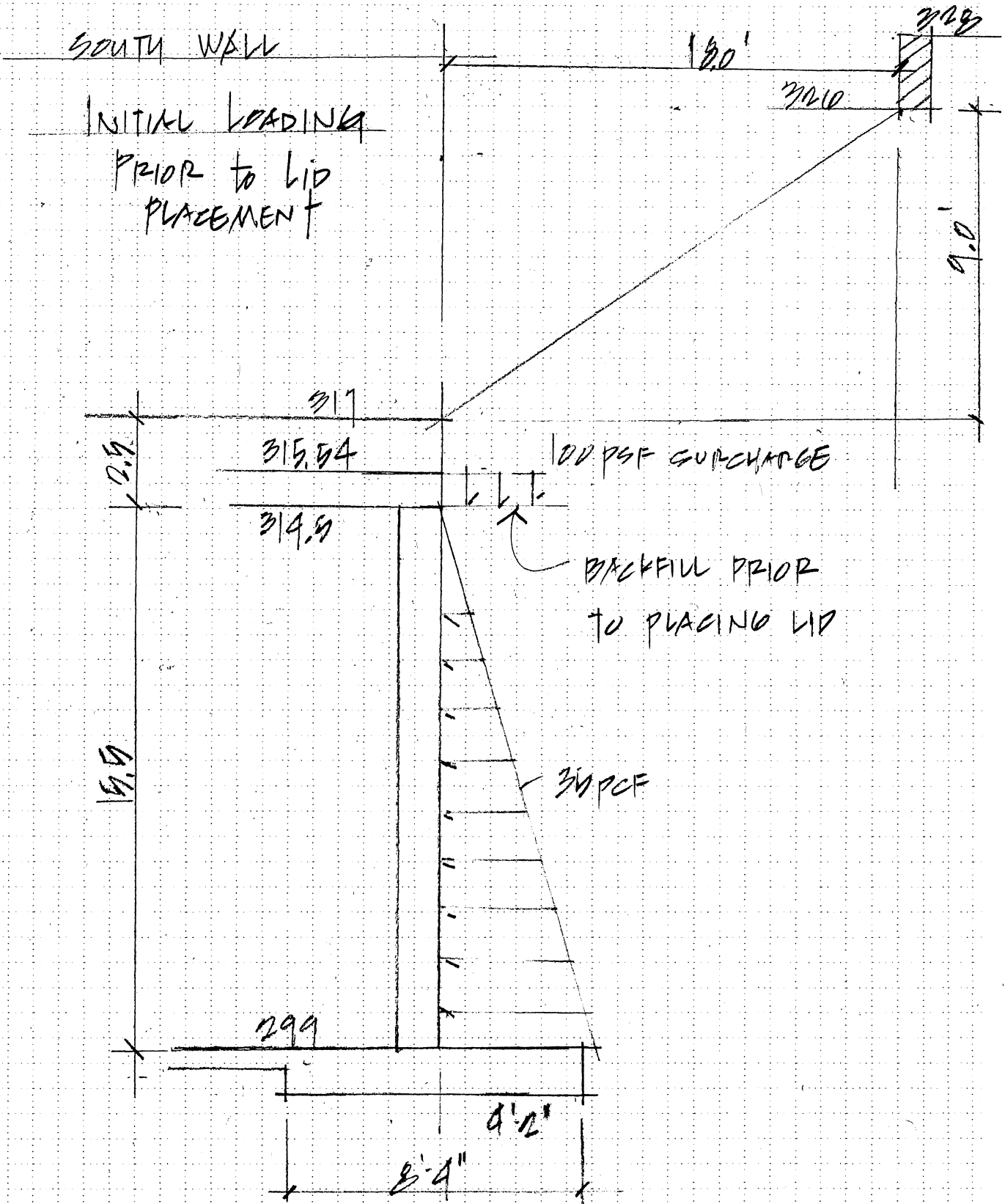

**SITE STRUCTURES**  
 10511 19th Ave SE, Suite C  
 Everett, WA, (425)-357-9600

Project Normandy Hgts

sheet 11  
 date 02-11-20  
 prj. no. S-26-009

**15.5FT RETAINING WALL REINFORCING Active Pressure + Surcharge**

		<u>H from top</u>	<u>Ms</u>	<u>Mu</u>	<u>As</u>
Wall thick	14 in ✓	1	20	32	0.001
Concrete cover	2 in ✓	2	103	164	0.003
Rebar size	7	3	284	454	0.009
Concrete Strength f'c	4000 psi	4	597	956	0.019
		5	1079	1727	0.035
Depth to rebar center	11.56	6	1764	2822	0.057
Comp block depth	1.33	7	2687	4299	0.086
		8	3883	6212	0.125
		9	5387	8618	0.173
		10	7233	11573	0.232
		11	9458	15133	0.304
		12	12096	19354	0.389
		13	15182	24291	0.488
EFWa(pcf)	35 ✓	14	18751	30001	0.603
Surcharge(psf)	100 ✓	15	22838	36540	0.734
Soil Density(pcf)	125				
		<u>H from top</u>	<u>Ms</u>	<u>Mu</u>	<u>As</u>
LF active	1.6	15.5	25086	40138	0.818
LF surcharge	1.6	14	18751	30001	0.612

**Vertical Reinforcing:**

bar size: # 6 ✓  
 spacing: 8 " o/c  
 As = 0.66 sq in ≥ 0.61

**Footing to Wall Dowels:**

bar size: # 7 ✓  
 spacing: 8 " o/c  
 tension controlled cracking:  $\rho \leq \rho_t$   
 $\rho = 0.0054$        $\rho_t = 0.0181$   
 development length: 41.5  
 Extend Dowels: 4.6 ft minimum into wall → go to 5 ft ✓  
 end hook development: 11.6  
 Embed Dowels: 10.5 in min into footing → go to 13 in into 16 in ftg

**Horizontal Reinforcing:**

bar size: # 5  
 spacing: 15 " o/c  
 each face: y       $\rho = 0.0029 \geq 0.0020$

**SITE STRUCTURES**

10511 19th Ave SE, Suite C  
 Everett, WA, (425)-357-9600

Project Normandy Hgts

sheet 12

date 02-11-20

prj. no. S-26-009

**15.5FT RETAINING WALL REINFORCING****Active Pressure + Surcharge**

Ha(ft)= 16.83 ✓	EFWa(pcf)= 35 ✓	Tw(in)= 14 ✓	Tftg(in)= 16.00 ✓
Hp(FT)= 1.00	EFWp(pcf)= 300	Hw(ft)= 15.5 ✓	Wftg(ft)= 8.33 ✓
	FSpasive= 1.00 ✓	D(wall)pcf= 150	Lheel(ft)= 4.17
CoeFrict= 0.50	Dsoil(pcf)= 125.00		Ltoe(ft)= 3.00
	Surchg(psf)= 100.00		D(ftg)pcf= 150
W(surchg)= 416.7		Allowalbe Bearing Pressure	<b>3500 psf</b>
W1(heel)= 8072	Fsrchg(lbs)= 471	LF oveturn= <b>1.5</b>	
W2(wall)= 2713	Fa(lbs)= 4957	Ms-ot(ft-lb)= 31773	
	Fp(lbs)= 150	Mu-ot(ft-lb)= 47660	
W4(ftg)= 1666	Ffrict(lbs)= 6434		
Wtotal= <b>12867</b>			
FS sliding= <b>1.21</b>	FS slide reqd= <b>1.50</b>	D key(ft)= 0.00	
Net Sliding= -1155			

Xcw(ft)= 2.92	Ecc-s(ft)= 2.47	Xresult-s(ft)= 5.38	Tr-s(ft)= 2.95
	Ecc-u(ft)= 3.70	Xresult-u(ft)= 6.62	Tr-u(ft)= 1.71
			3rd point= 2.78

CASE= Service

**RESULTANT WITHIN MIDDLE 3rd**

Tr (ft)= 2.95

Lbrg(ft)= 8.33	
Q1(psf)= <b>2902</b> ✓	≤ 3500 psf
Q2(psf)= <b>188</b>	

CASE= Ultimate

**RESULTANT OUTSIDE MIDDLE 3rd**

Tr (ft)= 1.71

Lbrg(ft)= 5.13	
Q1(psf)= <b>5014</b> ✓	≤ 1.5 × 3500 = 5250 psf
Q2(psf)= <b>0</b>	

**HEEL REINFORCING DESIGN**

Top bar cover (in)= 2  
 Top bar size = 6  
 Top bar spacing (in)= 8 ✓  
 Depth to Reinf d (in)= 13.63  
 Comp Block a (in)= 0.97  
 d - a/2 (in)= 13.14  
 As provided (sq in)= 0.66

Load Factor 1.5  
 Wall Mu= **37629** ft-lbs  
 Heel Mu based on Wdl 22637  
 Heel **Mu DESIGN**= 23000 ft-lbs @ wall  
 As reqd = 0.39 sq in per ft  
 As min = 0.55 sq in per ft  
 1.33 × As reqd = 0.52 sq in per ft

**TOE REINFORCING DESIGN**

Bot bar cover (in)= 3  
 Bot bar size = 6  
 Bot bar spacing (in)= 12 ✓  
 Depth to Reinf d (in)= 12.63  
 Comp Block a (in)= 0.65  
 d - a/2 (in)= 12.30  
 As provided (sq in)= 0.44

Wall Mu - Heel Mu 14992  
 Toe **Mu DESIGN** = 15000 ft-lbs @ wall  
 As reqd = 0.27 sq in per ft  
 As min = 0.51 sq in per ft  
 1.33 × As reqd = 0.36 sq in per ft



A Division of Koenig Engineering PC

Project NORMANDY HGTS

Sheet 13

Date 02-11-20

Job No S-26-009

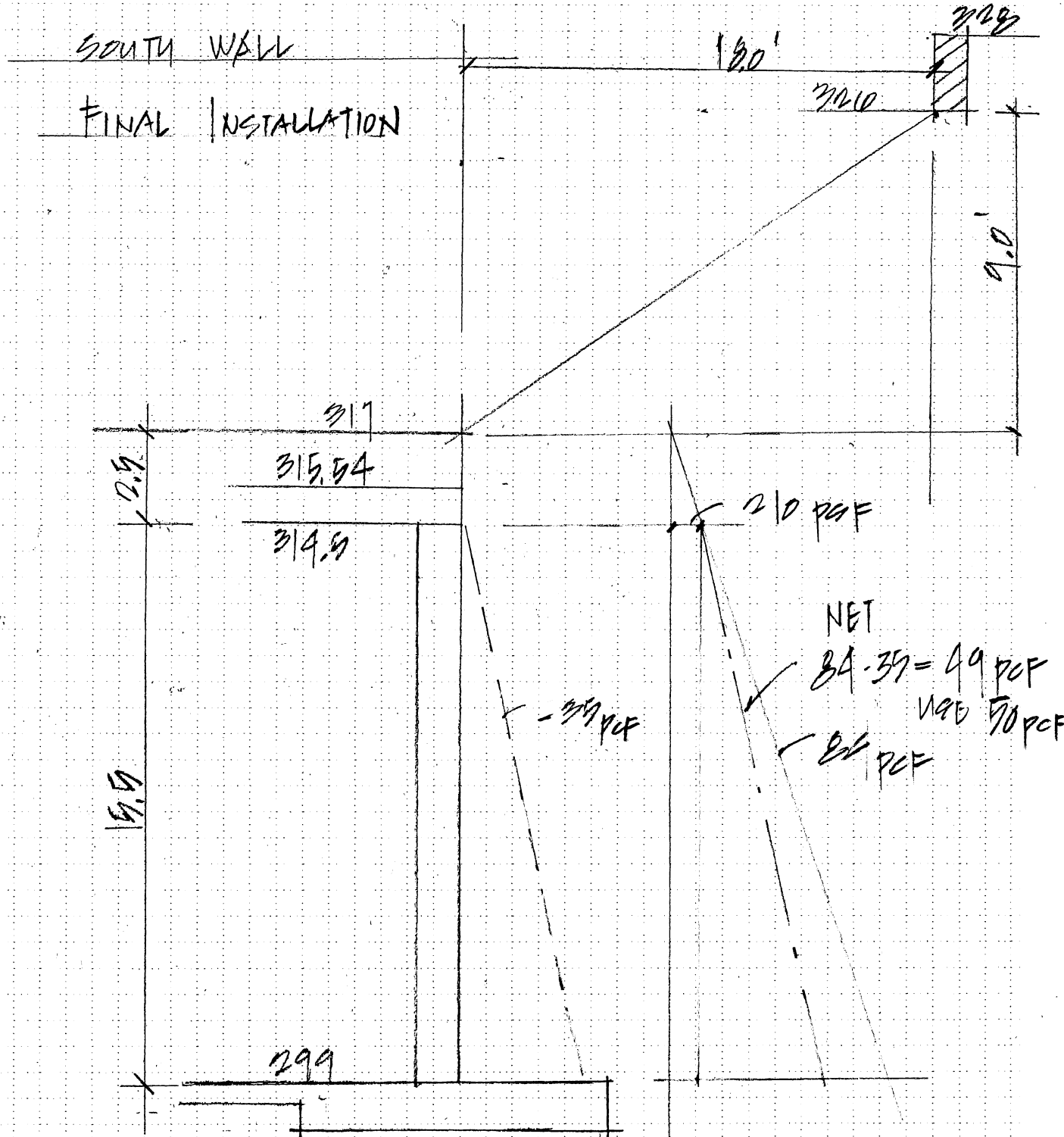

**SITE STRUCTURES**

10511 19th Ave SE, Suite C  
 Everett, WA, (425)-357-9600

Project Normandy Hgts

sheet 14

date 02-11-26

prj. no. S-26-009

**Design Data**

Soil Density	125 pcf	Ws1 =	0 psf
Soil Cover depth to the top of the wall	0 ft ✓	Ws2 =	775 psf
Wall height	15.5 ft ✓		
Soil Pressure EFW	50 pcf ✓		

**Surcharge Information**

uniform	S1 =	0 psf (on surface of ground)	Equiv Ws =	0 psf
truck	Ws =	0 psf (on surface of wall)		

Critical Design Surcharge pressure = ✓ 210 psf (on the surface of the wall)

**Calculated Design Forces**

W1= 210	F1 =	3255 lbs	R top =	3630 lbs
W2= 775	F2 =	6006 lbs	R bot =	5632 lbs
M1 = 6307	M total=	<b>18251</b> ft-lbs		
M2 = 11944				

**Wall Reinforcing**

Wall thickness	14 inches	Comp block (a) =	0.97 inches
Clear cover	2 inches	Depth to CL bar (d) =	11.63 inches
Rebar size	✓ 6	d-a/2 =	11.14 inches
Rebar area	0.44 sq-in		
Bar spacing	✓ 8 inches	ΦMn =	<b>33212</b> ft-lbs
Rebar strength fy	60 ksi		
Conc strength f'c	4000 psi	Mu =	<b>29201</b> ft-lbs
Load Factor	1.6		

max tension reinforcing spacing:  $f_s = 29674$  psi *OK*

s =	15.2 in
s =	16.2 in
s <sub>max</sub> =	<b>15.2 in - OK</b>

**Anchorage at Top of the Wall**

Ru = **5807** plf

#5 hairpins net #5@ 15"o/c  
 #5 hairpins net #5@ 18"o/c

ΦVn = 6700plf  
 ΦVn = 5580plf

**Anchorage at Bottom of the Wall**

Ru = **9011** plf

Nominal Shear friction capacity  
 of the footing to wall Dowel **14229** plf

Rebar Dowel Size =	5
Dowel Area =	0.31 sq-in
Dowel strength fy=	60 ksi
Dowel Spacing =	8 inches
Coefficient of friction =	0.6 smooth surface

**SITE STRUCTURES**

10511 19th Ave SE, Suite C  
Everett, WA, (425)-357-9600

Project NORMANDY HGTS

sheet: 15  
date 02-11-20  
prj. no. S-20-029

**Load Combination 1.2D+1.0E+1.0L+1.6H**

<b>E=</b>	442 psf		
<b>L=</b>	0 psf	Wall Height	Total Force
<b>Total=</b>	442 psf	15.50 ft	6851 lbs
<b>H=</b>	3255	6006	9261 lbs
<b>Total Force</b>			16112 lbs
Factored Load			21669 lbs
Average Load Factor			1.34

**SITE STRUCTURES**  
 10511 19th Ave SE, Suite C  
 Everett, WA, (425)-357-9600

Project Normandy Hgts

sheet 10  
 date 02-11-26  
 prj. no. S-26-009

**Design Data** 1.2D + 1.0E + 1.0L + 1.0H

Soil Density	125 pcf		
Soil Cover depth to the top of the wall	0 ft	Ws1 =	0 psf
Wall height	15.5 ft	Ws2 =	775 psf
Soil Pressure EFW	50 pcf		

**Surcharge Information**

uniform	S1 =	0 psf (on surface of ground)	Equiv Ws =	0 psf
truck	Ws =	0 psf (on surface of wall)		

Critical Design Surcharge pressure = 334 psf (on the surface of the wall)

**Calculated Design Forces**

W1= 334	F1 =	5177 lbs	R top =	4591 lbs
W2= 775	F2 =	6006 lbs	R bot =	6593 lbs
M1 = 10030	M total=	<b>21975</b> ft-lbs		
M2 = 11944				

**Wall Reinforcing**

Wall thickness	14 inches	Comp block (a) =	0.97 inches
Clear cover	2 inches	Depth to CL bar (d) =	11.63 inches
Rebar size	6	d-a/2 =	11.14 inches
Rebar area	0.44 sq-in		
Bar spacing	8 inches	$\Phi M_n =$	<b>33212</b> ft-lbs
Rebar strength $f_y$	60 ksi	$M_u =$	<b>29446</b> ft-lbs
Conc strength $f'_c$	4000 psi		
Load Factor	1.34		

max tension reinforcing spacing:  $f_s =$  35729 psi OK

s =	11.8 in
s =	13.4 in
$s_{max} =$	<b>11.8</b> in - OK

**Anchorage at Top of the Wall**

$R_u =$  **6151** plf

#5 hairpins net #5@ 15"o/c	$\Phi V_n =$ 6700plf
#5 hairpins net #5@ 18"o/c	$\Phi V_n =$ 5580plf

**Anchorage at Bottom of the Wall**

$R_u =$  **8834** plf

Nominal Shear friction capacity of the footing to wall Dowel	<b>14229</b> plf	Rebar Dowel Size =	5
		Dowel Area =	0.31 sq-in
		Dowel strength $f_y =$	60 ksi
		Dowel Spacing =	8 inches
		Coefficient of friction =	0.6 smooth surface

NORTH WALL

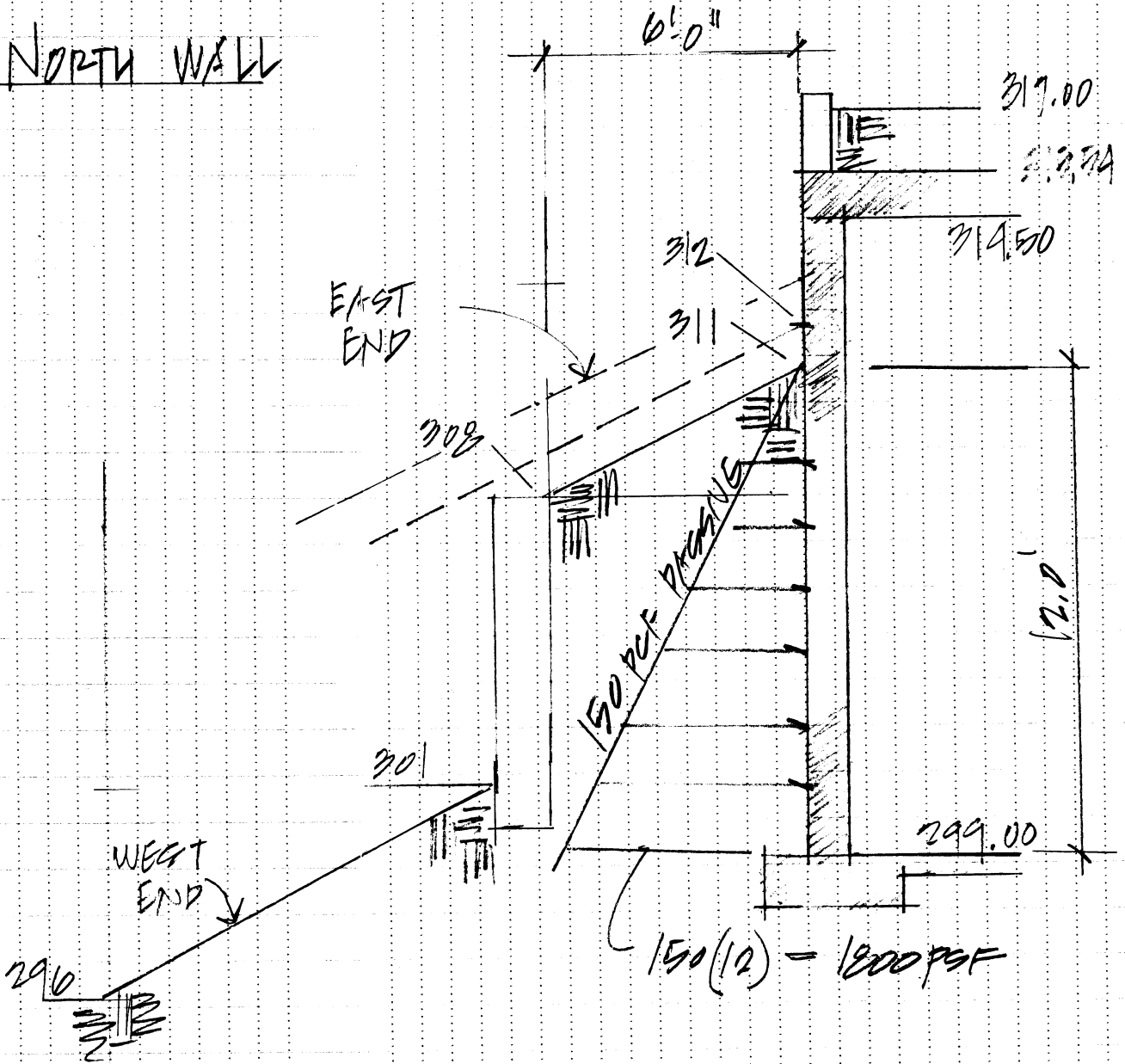

Current Date: 9/10/2003 6:12 AM  
 Units system: English  
 File name: C:\Program Files\RAM Advanse 6.5EN\Data\Normandy.adv

### Geometry data

#### GLOSSARY

- Cb22, Cb33 : Moment gradient coefficients
- Cm22, Cm33 : Coefficients applied to bending term in interaction formula
- d0 : Tapered member section depth at J end of member
- DJX : Rigid end offset distance measured from J node in axis X
- DJY : Rigid end offset distance measured from J node in axis Y
- DJZ : Rigid end offset distance measured from J node in axis Z
- DKX : Rigid end offset distance measured from K node in axis X
- DKY : Rigid end offset distance measured from K node in axis Y
- DKZ : Rigid end offset distance measured from K node in axis Z
- dL : Tapered member section depth at K end of member
- Ig factor : Inertia reduction factor (Effective Inertia/Gross Inertia) for reinforced concrete members
- K22 : Effective length factor about axis 2
- K33 : Effective length factor about axis 3
- L22 : Member length for calculation of axial capacity
- L33 : Member length for calculation of axial capacity
- LB pos : Lateral unbraced length of the compression flange in the positive side of local axis 2
- LB neg : Lateral unbraced length of the compression flange in the negative side of local axis 2
- RX : Rotation about X
- RY : Rotation about Y
- RZ : Rotation about Z
- TO : 1 = Tension only member 0 = Normal member
- TX : Translation in X
- TY : Translation in Y
- TZ : Translation in Z

#### Nodes

Node	X [ft]	Y [ft]	Z [ft]	Rigid Floor
1	0.00	0.00	0.00	0
2	0.00	15.50	0.00	0

#### Restraints

Node	TX	TY	TZ	RX	RY	RZ
1	1	1	1	0	0	0
2	1	0	0	0	0	0

#### Members

Member	NJ	NK	Description	Section	Material	d0 [in]	dL [in]	Ig factor
1	1	2		RcBeam 12x14in	C 4-60	0.00	0.00	0.00

Current Date: 9/10/2003 6:11 AM  
 Units system: English  
 File name: C:\Program Files\RAM Advanse 6.5EN\Data\Normandy.adv

### Load data

#### GLOSSARY

Comb : Indicates if load condition is a load combination (1= load combination. 0 = load case)

#### Load conditions

Condition	Description	Comb.	Category
PP	Passive pressure	0	LL

#### Distributed force on members

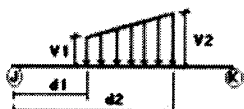

Condition	Member	Dir1	Val1 [Lb/ft]	Val2 [Lb/ft]	Dist1 [ft]	%	Dist2 [ft]	%
PP	1	x	-1800.00	0.00	0.00	No	12.00	No

#### Self weight multipliers for load conditions

Condition	Description	Self weight multiple			
		Comb.	MultX	MultY	MultZ
PP	Passive pressure	0	0.00	0.00	0.00

#### Seismic (Dynamic analysis only)

Condition	a/g	Ang. [Deg]	Damp. [%]
PP	0.00	0.00	0.00

Current Date: 9/10/2003 1:01 AM  
 Units system: English  
 File name: C:\Program Files\RAM Advanse 6.5EN\Data\Normandy.adv

### Analysis Results

#### Reactions

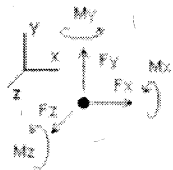

Direction of positive forces and moments

Node	Forces [Lb]			Moments [Lb*ft]		
	FX	FY	FZ	MX	MY	MZ
Condition PP=Passive pressure						
1	8012.90350	0.00000	0.00000	0.00000	0.00000	0.00000
2	2787.09650	0.00000	0.00000	0.00000	0.00000	0.00000
SUM	10800.00000	0.00000	0.00000	0.00000	0.00000	0.00000

#### Member forces at fixed stations

CONDITION PP=Passive pressure						
	M33 [Lb*ft]	V2 [Lb]	M22 [Lb*ft]	V3 [Lb]	Axial [Lb]	Torsion [Lb*ft]
MEMBER 1						
0%	0.00	8012.90	0.00	0.00	0.00	0.00
5%	-5951.45	6594.40	0.00	0.00	0.00	0.00
11%	-10786.42	5275.72	0.00	0.00	0.00	0.00
16%	-14586.34	4056.86	0.00	0.00	0.00	0.00
21%	-17432.65	2937.83	0.00	0.00	0.00	0.00
26%	-19406.80	1918.63	0.00	0.00	0.00	0.00
32%	-20590.20	999.26	0.00	0.00	0.00	0.00
37%	-21064.31	179.71	0.00	0.00	0.00	0.00
42%	-20910.57	-540.01	0.00	0.00	0.00	0.00
47%	-20210.40	-1159.90	0.00	0.00	0.00	0.00
53%	-19045.25	-1679.96	0.00	0.00	0.00	0.00
58%	-17496.55	-2100.20	0.00	0.00	0.00	0.00
63%	-15645.75	-2420.61	0.00	0.00	0.00	0.00
68%	-13574.27	-2641.20	0.00	0.00	0.00	0.00
74%	-11363.57	-2761.96	0.00	0.00	0.00	0.00
79%	-9094.74	-2787.10	0.00	0.00	0.00	0.00
84%	-6821.05	-2787.10	0.00	0.00	0.00	0.00
89%	-4547.37	-2787.10	0.00	0.00	0.00	0.00
95%	-2273.68	-2787.10	0.00	0.00	0.00	0.00
100%	0.00	-2787.10	0.00	0.00	0.00	0.00

MAX MOM  
 14" thick wall #7 @ 10" c  
 $\phi M_n = 35821 \text{ l-ft}$   
 $LF = \frac{35821}{21064} = 1.84 \text{ ok}$

**SITE STRUCTURES**

10511 19th Ave SE, Suite C  
 Everett, WA, (425)-357-9600

Project Normandy Hgts

sheet 21  
 date 02-11-20  
 prj. no. S-26-009

**Design Data**

**FULLY BURIED EAST WALL**

Soil Density	125 pcf		
Soil Cover depth to the top of the wall	2.5 ft	Ws1 =	137.5 psf
Wall height	15.5 ft	Ws2 =	852.5 psf
Soil Pressure EFW	55 pcf		

**Surcharge Information**

uniform	S1 =	150 psf (on surface of ground)	Equiv Ws =	66 psf
truck	Ws =	0 psf (on surface of wall)		

Critical Design Surcharge pressure = 66 psf (on the surface of the wall)

**Calculated Design Forces**

W1= 203.5	F1 =	3154 lbs	R top =	3779 lbs
W2= 852.5	F2 =	6607 lbs	R bot =	5982 lbs
M1 = 6111	M total=	<b>19250</b> ft-lbs		
M2 = 13139				

**Wall Reinforcing**

Wall thickness	14 inches	Comp block (a) =	1.06 inches
Clear cover	2 inches	Depth to CL bar (d) =	11.56 inches
Rebar size	7 ✓	d-a/2 =	11.03 inches
Rebar area	0.60 sq-in		
Bar spacing	10 inches ✓	ΦMn =	<b>35821</b> ft-lbs
Rebar strength fy	60 ksi	Mu =	<b>30800</b> ft-lbs
Conc strength f'c	4000 psi		
Load Factor	1.6		

max tension reinforcing spacing:	f <sub>s</sub> =	29019 psi	s =	15.7 in
			s =	16.5 in
			s <sub>max</sub> =	<b>15.7 in - OK</b>

**Anchorage at Top of the Wall**

Ru = **6047** plf

#5 hairpins net #5@ 15"o/c	ΦVn = 6700plf
#5 hairpins net #5@ 18"o/c	ΦVn = 5580plf

**Anchorage at Bottom of the Wall**

Ru = **9571** plf

Nominal Shear friction capacity of the footing to wall Dowel	<b>11383</b> plf	Rebar Dowel Size =	5
		Dowel Area =	0.31 sq-in
		Dowel strength fy=	60 ksi
		Dowel Spacing =	10 inches
		Coefficient of friction =	0.6 smooth surface

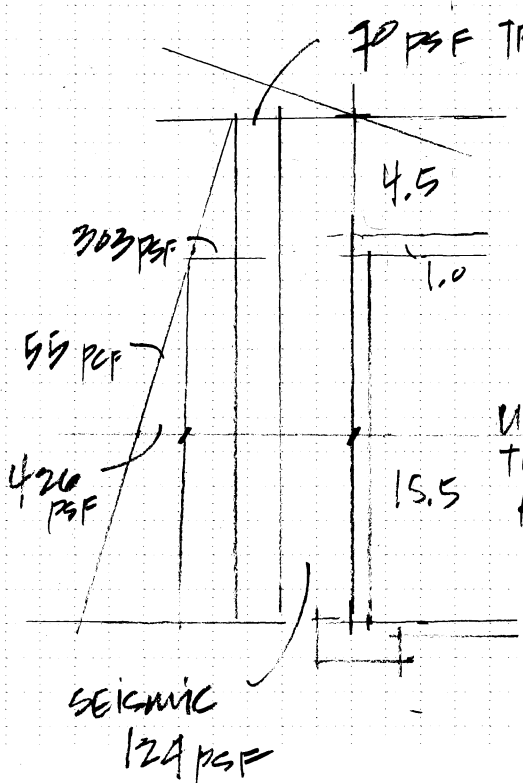
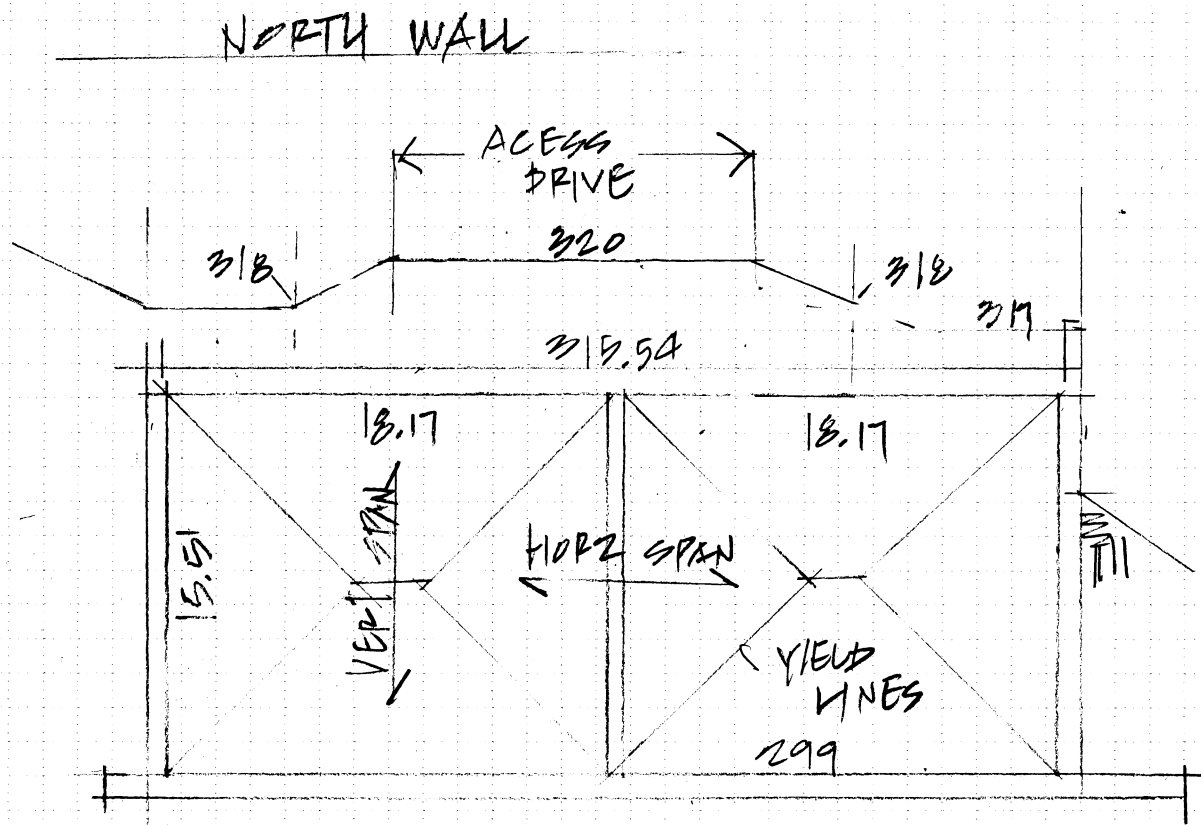

USE 50% OF THIS FORCE FOR HORIZ REINF REVIEW

$$\text{CASE 1} = 1.0H + 1.0L$$

$$1.0(303 + 70) \frac{1}{2} = 198 \text{ PSF}$$

$$\text{CASE 2} = 1.0E + 1.0L + 1.0H$$

$$1.0\left(\frac{124}{2}\right) + 1.0\left(\frac{70}{2}\right) + 1.0\left(\frac{303}{2}\right) = 340 \text{ PSF}$$

ADD IN 30% OF 55 PSF @ MID DEPTH

$$+ W_u = 420(0.30)1.0 = 200 \text{ PSF}$$

Current Date: 9/10/2003 6:10 AM  
 Units system: English  
 File name:

## Geometry data

### GLOSSARY

- Cb22, Cb33 : Moment gradient coefficients
- Cm22, Cm33 : Coefficients applied to bending term in interaction formula
- d0 : Tapered member section depth at J end of member
- DJX : Rigid end offset distance measured from J node in axis X
- DJY : Rigid end offset distance measured from J node in axis Y
- DJZ : Rigid end offset distance measured from J node in axis Z
- DKX : Rigid end offset distance measured from K node in axis X
- DKY : Rigid end offset distance measured from K node in axis Y
- DKZ : Rigid end offset distance measured from K node in axis Z
- dL : Tapered member section depth at K end of member
- Ig factor : Inertia reduction factor (Effective Inertia/Gross Inertia) for reinforced concrete members
- K22 : Effective length factor about axis 2
- K33 : Effective length factor about axis 3
- L22 : Member length for calculation of axial capacity
- L33 : Member length for calculation of axial capacity
- LB pos : Lateral unbraced length of the compression flange in the positive side of local axis 2
- LB neg : Lateral unbraced length of the compression flange in the negative side of local axis 2
- RX : Rotation about X
- RY : Rotation about Y
- RZ : Rotation about Z
- TO : 1 = Tension only member 0 = Normal member
- TX : Translation in X
- TY : Translation in Y
- TZ : Translation in Z

### Nodes

Node	X [ft]	Y [ft]	Z [ft]	Rigid Floor
1	0.00	0.00	0.00	0
2	18.20	0.00	0.00	0
3	36.40	0.00	0.00	0

### Restraints

Node	TX	TY	TZ	RX	RY	RZ
1	1	1	1	1	1	1
2	0	1	1	0	0	0
3	1	1	1	1	1	1

### Members

Member	NJ	NK	Description	Section	Material	d0 [in]	dL [in]	lg factor
1	1	2		RcBeam 12x14in	C 4-60	0.00	0.00	0.00
2	2	3		RcBeam 12x14in	C 4-60	0.00	0.00	0.00

02-11-26

S-26-009

Current Date: 9/10/2003 6:09 AM  
 Units system: English  
 File name:

## Load data

### GLOSSARY

Comb : Indicates if load condition is a load combination (1= load combination. 0 = load case)

### Load conditions

Condition	Description	Comb.	Category
Wu	factored load	0	DL

### Distributed force on members

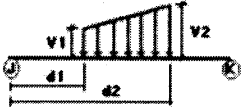

Condition	Member	Dir1	Val1	Val2	Dist1	%	Dist2	%
			[Lb/ft]	[Lb/ft]			[ft]	
Wu	1	Y	-540.00	-540.00	0.00	No	100.00	Yes
	2	Y	-540.00	-540.00	0.00	No	100.00	Yes

### Self weight multipliers for load conditions

Condition	Description	Self weight multiplie			
		Comb.	MultX	MultY	MultZ
Wu	factored load	0	0.00	0.00	0.00

### Seismic (Dynamic analysis only)

Condition	a/g	Ang. [Deg]	Damp. [%]
Wu	0.00	0.00	0.00

Current Date: 9/10/2003 4:41 AM  
 Units system: English  
 File name:

## Analysis Results

### Reactions

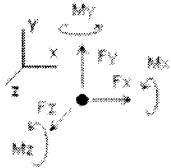

Direction of positive forces and moments

Node	Forces [Lb]			Moments [Lb*ft]		
	FX	FY	FZ	MX	MY	MZ
Condition Wu=factored load						
1	0.00000	4914.00000	0.00000	0.00000	0.00000	14905.80000
2	0.00000	9828.00000	0.00000	0.00000	0.00000	0.00000
3	0.00000	4914.00000	0.00000	0.00000	0.00000	-14905.80000
SUM	0.00000	19656.00000	0.00000	0.00000	0.00000	0.00000

### Member forces at fixed stations

CONDITION Wu=factored load						
	M33 [Lb*ft]	V2 [Lb]	M22 [Lb*ft]	V3 [Lb]	Axial [Lb]	Torsion [Lb*ft]
MEMBER 1						
0%	-14905.80	-4914.00	0.00	0.00	0.00	0.00
5%	-10446.45	-4396.74	0.00	0.00	0.00	0.00
11%	-6482.58	-3879.47	0.00	0.00	0.00	0.00
16%	-3014.19	-3362.21	0.00	0.00	0.00	0.00
21%	-41.29	-2844.95	0.00	0.00	0.00	0.00
26%	2436.13	-2327.68	0.00	0.00	0.00	0.00
32%	4418.06	-1810.42	0.00	0.00	0.00	0.00
37%	5904.51	-1293.16	0.00	0.00	0.00	0.00
42%	6895.48	-775.89	0.00	0.00	0.00	0.00
47%	7390.96	-258.63	0.00	0.00	0.00	0.00
53%	7390.96	258.63	0.00	0.00	0.00	0.00
58%	6895.48	775.89	0.00	0.00	0.00	0.00
63%	5904.51	1293.16	0.00	0.00	0.00	0.00
68%	4418.06	1810.42	0.00	0.00	0.00	0.00
74%	2436.13	2327.68	0.00	0.00	0.00	0.00
79%	-41.29	2844.95	0.00	0.00	0.00	0.00
84%	-3014.19	3362.21	0.00	0.00	0.00	0.00
89%	-6482.58	3879.47	0.00	0.00	0.00	0.00
95%	-10446.45	4396.74	0.00	0.00	0.00	0.00
100%	-14905.80	4914.00	0.00	0.00	0.00	0.00
MEMBER 2						
0%	-14905.80	-4914.00	0.00	0.00	0.00	0.00
5%	-10446.45	-4396.74	0.00	0.00	0.00	0.00
11%	-6482.58	-3879.47	0.00	0.00	0.00	0.00
16%	-3014.19	-3362.21	0.00	0.00	0.00	0.00
21%	-41.29	-2844.95	0.00	0.00	0.00	0.00
26%	2436.13	-2327.68	0.00	0.00	0.00	0.00
32%	4418.06	-1810.42	0.00	0.00	0.00	0.00

MAX POS MOMENT

MAX NEG MOMENT

SHEET 21

02-11-26

S-26-009

37%	5904.51	-1293.16	0.00	0.00	0.00	0.00
42%	6895.48	-775.89	0.00	0.00	0.00	0.00
47%	7390.96	-258.63	0.00	0.00	0.00	0.00
53%	7390.96	258.63	0.00	0.00	0.00	0.00
58%	6895.48	775.89	0.00	0.00	0.00	0.00
63%	5904.51	1293.16	0.00	0.00	0.00	0.00
68%	4418.06	1810.42	0.00	0.00	0.00	0.00
74%	2436.13	2327.68	0.00	0.00	0.00	0.00
79%	-41.29	2844.95	0.00	0.00	0.00	0.00
84%	-3014.19	3362.21	0.00	0.00	0.00	0.00
89%	-6482.58	3879.47	0.00	0.00	0.00	0.00
95%	-10446.45	4396.74	0.00	0.00	0.00	0.00
100%	-14905.80	4914.00	0.00	0.00	0.00	0.00

---

HORZ WALL SPAN - 2 SPAN - FIXED ENDS

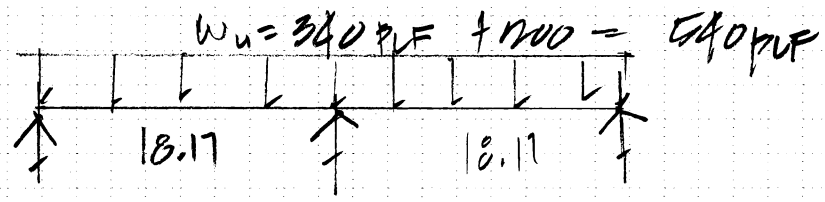

-  $M_u$  @ supports = 9,900 l-#  
+  $M_u$  @ MID SPAN = 4,690 l-#

4" THK WALL 2" CUR #5 @ 16"  $a = 0.34"$   
 $\phi M_n = 11,900 \text{ l-#} / \text{ok}$

ADD in 30% OF HYDRO PRESSURE @ MID HEIGHT

$w_u = 340 + 200 = 540 \text{ pcf}$

<p>- <math>M_u</math> @ supports = 14,900 l-# + <math>M_u</math> @ MID SPAN = 7,390 l-#</p>
<p>#5 @ 12" <math>\phi M_n = 15,840 \text{ l-#}</math></p>

VERT WALL SPAN USE LF = 1.0

$w = \frac{303}{2} + \frac{70}{2} \left( \frac{1}{1.0} \right) + \frac{124}{2} \left( \frac{1}{1.0} \right) = 212 \text{ psf w/ seismic}$

174 w/o seismic

**SITE STRUCTURES**

10511 19th Ave SE, Suite C  
 Everett, WA, (425)-357-9600

Project Normandy Hgts

sheet 29  
 date 02-11-26  
 prj. no. S-26-009

**Design Data**

WEST WALL - H + L

Soil Density	125 pcf	Ws1 =	0 psf
Soil Cover depth to the top of the wall	0 ft	Ws2 =	434 psf
Wall height	15.5 ft		
Soil Pressure EFW	28 pcf		

**Surcharge Information**

uniform	S1 =	0 psf (on surface of ground)	Equiv Ws =	0 psf
truck	Ws =	0 psf (on surface of wall)		

Critical Design Surcharge pressure =  174 psf (on the surface of the wall)

**Calculated Design Forces**

W1 = 174	F1 =	2697 lbs	R top =	2470 lbs
W2 = 434	F2 =	3364 lbs	R bot =	3591 lbs
M1 = 5225	M total =	<b>11914</b> ft-lbs		
M2 = 6689				

**Wall Reinforcing**

Wall thickness	14 inches	Comp block (a) =	0.65 inches
Clear cover	2 inches	Depth to CL bar (d) =	11.63 inches
Rebar size	6 ✓	d-a/2 =	11.30 inches
Rebar area	0.44 sq-in	ΦMn =	<b>22465</b> ft-lbs
Bar spacing	12 inches ✓	Mu =	<b>19063</b> ft-lbs
Rebar strength fy	60 ksi		
Conc strength f'c	4000 psi		
Load Factor	1.6		

max tension reinforcing spacing:	f <sub>s</sub> =	28639 psi ↓	s =	16.0 in
			s =	16.8 in
			s <sub>max</sub> =	<b>16.0 in - OK</b>

**Anchorage at Top of the Wall**

Ru = **3951** plf

#5 hairpins net #5@ 15"o/c  
 #5 hairpins net #5@ 18"o/c

ΦVn = 6700plf  
 ΦVn = 5580plf

**Anchorage at Bottom of the Wall**

Ru = **5745** plf

Nominal Shear friction capacity  
 of the footing to wall Dowel **9486** plf

Rebar Dowel Size =	5
Dowel Area =	0.31 sq-in
Dowel strength fy =	60 ksi
Dowel Spacing =	12 inches
Coefficient of friction =	0.6 smooth surface

**SITE STRUCTURES**  
 10511 19th Ave SE, Suite C  
 Everett, WA, (425)-357-9600

Project Normandy Hgts

sheet 20  
 date 02-11-26  
 prj. no. S-26-009

**Design Data**

*NET WALL E + L + H*

Soil Density	125 pcf	Ws1 =	0 psf
Soil Cover depth to the top of the wall	0 ft	Ws2 =	434 psf
Wall height	15.5 ft		
Soil Pressure EFW	28 pcf		

**Surcharge Information**

uniform	S1 =	0 psf (on surface of ground)	Equiv Ws =	0 psf
truck	Ws =	0 psf (on surface of wall)		

Critical Design Surcharge pressure = 212 psf (on the surface of the wall)

**Calculated Design Forces**

W1 = 212	F1 =	3286 lbs	R top =	2764 lbs
W2 = 434	F2 =	3364 lbs	R bot =	3885 lbs
M1 = 6367	M total =	<b>13055</b> ft-lbs		
M2 = 6689				

**Wall Reinforcing**

Wall thickness	14 inches	Comp block (a) =	0.65 inches
Clear cover	2 inches	Depth to CL bar (d) =	11.63 inches
Rebar size	6	d-a/2 =	11.30 inches
Rebar area	0.44 sq-in		
Bar spacing	12 inches	$\Phi M_n =$	<b>22465</b> ft-lbs
Rebar strength $f_y$	60 ksi	$M_u =$	<b>20889</b> ft-lbs <i>ok</i>
Conc strength $f'_c$	4000 psi		
Load Factor	1.6		

max tension reinforcing spacing:  $f_s =$  31383 psi *ok*

s =	14.1 in
s =	15.3 in
$s_{max} =$	<b>14.1</b> in - OK

**Anchorage at Top of the Wall**

$R_u =$  **4423** plf

#5 hairpins net #5@ 15"o/c	$\Phi V_n =$ 6700plf
#5 hairpins net #5@ 18"o/c	$\Phi V_n =$ 5580plf

**Anchorage at Bottom of the Wall**

$R_u =$  **6217** plf

Nominal Shear friction capacity of the footing to wall Dowel **9486** plf

Rebar Dowel Size =	5
Dowel Area =	0.31 sq-in
Dowel strength $f_y =$	60 ksi
Dowel Spacing =	12 inches
Coefficient of friction =	0.6 smooth surface

LID TO WALL CLOSURE REINF

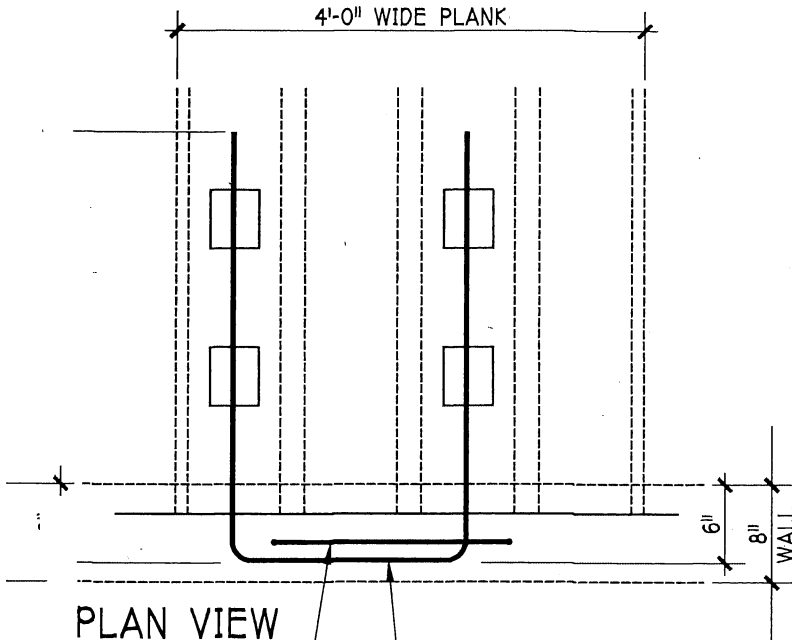

PLAN VIEW

CLOSURE TO WALL DOWELS @  
 LID TO CLOSURE DOWELS @ EA PLANK.

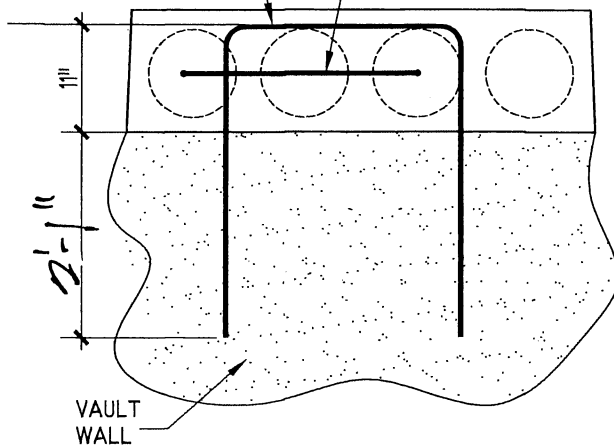

ELEVATION VIEW

BAR SPACING 1/2"  
SHEAR FRICTION

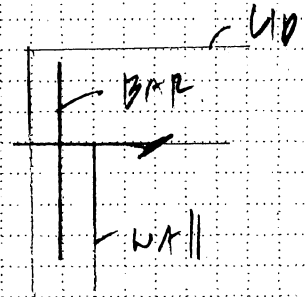

$\mu = 0.40 \quad f_y = 60 \text{ ksi}$

BAR	$\phi V_n$
#9 @ 1/2	8370 PLF

#0 11,900 PLF

#5  $\left[ \begin{matrix} 12'' \\ 12'' \end{matrix} \right]$

#5 =  $0.75(0.31)60(0.60)$   
= 8370 PLF

#6 =  $0.75(0.44)60(0.60)$   
11,900 PLF

PARS @ 2' 11 1/2

#5 @ 18 1/2  $\phi V_n = 5580 \text{ PLF}$   
#5 @ 15 1/2  $\phi V_n = 6700 \text{ PLF}$

#5 = 4185 PLF  
#0 = 5950 PLF

**SITE STRUCTURES**

10511 19th Ave SE, Suite C  
 Everett, WA, (425)-357-9600

Project Normandy Hgts

sheet 32  
 date 02-11-20  
 prj. no. S-26-009

**INTERIOR WALL HEADER GEOMETRY AND LOADS ANALYSIS****Header Overburden & Uniform Loads**

Lid weight	90 psf		
Soil Density	125 pcf	Load	Factors
Soil Cover depth over lid	1.5 ft	LL	1.6
Plank design clear span left	18.2 ft	DL	1.2
Plank design clear span right	18.2 ft		
Design Uniform Live Load	150 psf		
Lid tributary width to header	18.2 ft		
Uniform service load to header	7781 plf		
Uniform factored load to header	10429 plf		

**Truck Wheel Loads to Header**

Truck type	HS-20
Axle Load	32000 lbs
Wheel Spacing	6 ft
Cover depth	1.5 ft

Axle assumed centered over & perpendicular to header

distribution width	3.50 ft	opening width	8.00 ft
distribution length	10.00 ft	length ea side of hdr	5.00 ft

uniform load @ top of plank	914 psf
wheel load to header from left span	3943 plf
wheel load to header from right span	3943 plf
Total wheel load to header	7887 plf
Factored wheel load to header	12619 plf

**Design Loads & Forces in Header**

Service	15.7 klf
Factored	23.0 klf

Critical section for shear is at 1.2 feet from the face of the support

Design Vu =	65 k
Design Mu =	184 k-ft

**SITE STRUCTURES**

10511 19th Ave SE, Suite C  
 Everett, WA, (425)-357-9600

Project Normandy Hgts

sheet 33

date 02-11-20

prj. no. S-26-009

**INTERIOR WALL HEADER DESIGN****Header Data**

Header width	8 inches	Concrete Strength	4000 psi
Header span	8.00 ft		
Header depth	48 inches	d =	45.00 inches
In/d ratio	2.13	Deep Beam limit In/d < 5.0	
Min shear steel ( Area / spacing ) ratio	0.012	Min Rebar spacing	
Max spacing of shear steel	9.6 inches	# 3 @	9.17
		# 4 @	16.67
Min horiz steel ( Area / spacing ) ratio	0.02	# 4 @	10.00
Max spacing of horizontal steel	16 inches	# 5 @	15.50

**Review shear capacity of header**

Reinforcing yield strength	60 ksi	# 4 $\downarrow$ $\frac{11}{16}$	
Shear reinforcing area	0.20 sq in	Horz reinf area	0.31 sq in
spacing	8 in	Horz reinf spacing	12 in
Reinf shear capacity $\Phi V_s$	63 k	Conc shear capacity $\Phi V_c$	39 k
Total Shear Capacity	101 k	Factored shear $V_u$	65 k
Max $\Phi V_n$ @ In/d < 2	155 k		
Max $\Phi V_n$ @ 2 < In/d < 5	16782 k		

**Review flexural capacity of header**

min $A_s$ based on 200 bwd/fy	1.2 sq inches	
min $A_s$ based on eq 10-3	1.14 sq inches	
$A_s$ reqd based on bending model	0.95 sq inches	$(\frac{3}{8}) \# 10 = 1.32$
$A_s$ reqd based on tie - strut model		
assume $V_u$ is focused @ the center of the header		
then $T_u$ =	68.84 k	
$A_s$ reqd =	1.27 sq inches	

**SITE STRUCTURES**  
 10511 19th Ave SE, Suite C  
 Everett, WA, (425)-357-9600

Project Normandy Hgts

sheet  
 date  
 prj. no.

34  
02-11-26  
S-26-009

**Design Data : Wall Foundation Loads Analysis**

Soil Desity	125 pcf	Per. wall Cell Width	18.2 ft
Soil Cover over the lid	1.5 ft		
		Int. wall Cell Width left	18.2 ft
Plank weight	90 psf	Int. wall Cell Width right	18.2 ft
Uniform Live Load	150 psf		
Truck Rating	HS20-44	Front Axle Load	8000 lbs
		Rear Axle #1 Load	32000 lbs
Wall Height	15.5 ft	Rear Axle #2 Load	<u>32000 lbs</u>
		Total vehicle wt	<u>72000 lbs</u>

**Truck Wheel Load Distribution to Perimeter Wall Foundation**

Truck Perpendicular to the perimeter wall w/ rear axle #2 directly over wall & distance to axle #1 = 14ft

total truck load to wall =	39385 lbs		
distribution width =	42 ft	Load @ base of wall =	<b>938 plf</b>

Truck Parallel to the perimeter wall w/ one wheel over wall & 2nd wheel on plank (incl axle 1&2 only )

total truck load to wall =	53451 lbs		
calc distribution width =	50 ft	Load @ base of wall =	<b>1069 plf</b>

**Truck Wheel Load Distribution to Interior Wall Foundation**

Truck Perpendicular to the int. wall w/ rear axle #2&#1 centered over the wall & dist between axles = 14ft

total truck load to wall =	39385 lbs		
distribution width =	42 ft	Load @ base of wall =	<b>938 plf</b>

Truck Perpendicular to the interior wall w/ rear axle #2 directly over wall & distance to axle #1 = 14ft

total truck load to wall =	39385 lbs left plank	Load @ base of wall =	<b>938 plf</b>
total truck load to wall =	39385 lbs right plank	Load @ base of wall =	<b>938 plf</b>
distribution width =	42 ft		

Truck Parallel to the interior wall w/ one wheel over wall & 2nd wheel on plank (incl axle 1&2 only )

total truck load to wall =	53451 lbs left plank	Load @ base of wall =	<b>1069 plf</b>
total truck load to wall =	53451 lbs right plank	Load @ base of wall =	<b>1069 plf</b>
distribution width =	50 ft		

Truck Parallel to the interior wall w/ the truck centered over the wall (incl axle 1&2 only )

total truck load to wall =	53451 lbs		
distribution width =	50 ft	Load @ base of wall =	<b>1069 plf</b>

**Uniform Live Load distribution to Wall Footings**

Perimeter Wall	<b>1365 plf</b>
Interior Wall	<b>2730 plf</b>

**SITE STRUCTURES**  
 10511 19th Ave SE, Suite C  
 Everett, WA, (425)-357-9600

Project Normandy Hgts

sheet  
 date  
 prj. no.

35  
02-11-20  
S-26-009

**Design Data : Wall Foundation Design**

Allowable Bearing Pressure	3500 psf	Per. wall Cell Width	18 ft
Rebar strength $f_y$ =	60 ksi	Int. wall Cell Width left	18 ft
Concrete strength =	4000 psi	Int. wall Cell Width right	18 ft
Soil Desity	125 pcf	Plank weight	90 psf
Soil Cover over the lid	1.5 ft	Wall Height	15.5 ft
		Wall Thickness	14 inches

**Perimeter Wall Footing Design**

		<u>L.F</u>	<u>Wu</u>
Design live load	1365 plf	1.6	2184 plf
Soil Cover dead load	1925 plf	1.2	2310 plf
Plank dead load	924 plf	1.2	1108.8 plf
Wall dead load	2712.5 plf	1.2	3255 plf
<u>total dead load</u>	<u>5562 plf</u>		<u>6673.8 plf</u>
Total live + dead Load	6927 plf		8858 plf
Required Ftg Width	1.98 ft		
Selected Ftg Width	2.33 ft		Selected Ftg Thickness 12 in

*but to F42x16*

Qu =	3802 psf	Mu =	643 ft-lbs	at face of wall
		Vu =	2211 plf	at face of wall
As regd =	0.02 sq-in/ft	phi Vn =	10967 plf	at face of wall
Asmin =	0.35 sq-in/ft			
1.33 x As regd =	0.02 sq-in/ft			

**Interior Wall Footing Design**

		<u>L.F</u>	<u>Wu</u>
Design live load	2730 plf	1.6	4368 plf
Soil Cover dead load	3413 plf	1.2	4095 plf
Plank dead load	1638 plf	1.2	1965.6 plf
Wall dead load	2712.5 plf	1.2	3255 plf
<u>total dead load</u>	<u>7763 plf</u>		<u>9315.6 plf</u>
Total live + dead Load	10493 plf		13683.6 plf
Required Ftg Width	3.00 ft		
Selected Ftg Width	3.33 ft		Selected Ftg Thickness 12 in

*F40x12*

Qu =	4109 psf	Mu =	2404 ft-lbs	at face of wall
		Vu =	4445 plf	at face of wall
As regd =	0.06 sq-in/ft	phi Vn =	10967 plf	at face of wall
Asmin =	0.35 sq-in/ft			
1.33 x As regd =	0.09 sq-in/ft			

**SITE STRUCTURES**  
 10511 19th Ave SE, Suite C  
 Everett, WA, (425)-357-9600

Project Normandy Hgts

sheet: 3/0  
 date: 12-11-20  
 prj. no. S-26-009

**Reinforcing at Top of Wall Below Grated Opening**

**Design Data**

Top of Footing to Inside Top of Vault (H1)	15.5 ft	curb height	1.5 ft
Top of Footing to Finished Grade (H2)	18 ft	curb horz reinf bar area	0.2
Soil Pressure EFW	55 pcf	curb horz reinf spacing	12 in o/c
Controlling Lateral Surcharge	70 psf	depth to center of reinf	3 in
Grating Span	10 ft	curb thickness	6 in

SURCHARGE

SOIL PRESSURE

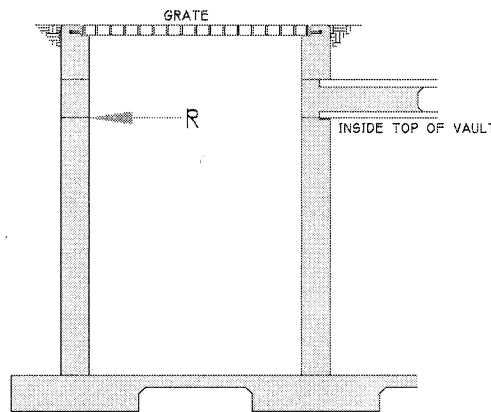
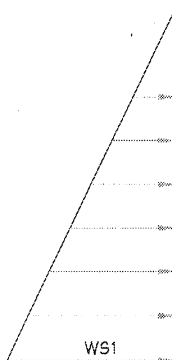
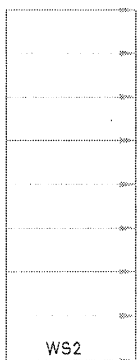

Ws1 = 990  
 Ws2 = 70

**Calculated Design Forces**

$F_{on\ curb} =$	111.25 plf avg	$Mu_{horz\ curb} =$	1391 ft-lbs	
$F_{bot\ of\ curb} =$	152.5 plf	$\phi Mn_{curb} =$	2250 ft-lbs	curb self-supported
$F_{bot\ of\ wall} =$	1060 plf			
$M_{wall\ uniform} =$	20759 ft-lbs	$M_{base\ of\ wall} =$	54895 ft-lbs	
$M_{wall\ triangle} =$	34136 ft-lbs	$R =$	3542 plf	
Load Factor	1.6	$Mu_{horz\ wall} =$	70832 ft-lbs	
$Wu =$	5667			

**Wall Reinforcing**

Wall Thickness	14 in	Addl Horz Reinf	6
Clear Cover	2 in	# of Addl Bars	3
Vert Rebar Size	7	As @ Top of Wall	1.33 sq-in
Rebar Area	0.60 sq-in		
conc strength $f_c$	4000 psi	depth to reinf (d)	10.75 in
Closure Reinf	(3) - # 6	comp block (a)	1.95 in
As in Closure	1.33 sq-in	d - a/2	9.78 in
$\phi Mn =$	<b>116601 ft-lbs</b>	$Mu =$	<b>70832 ft-lbs</b>

*Add (3) # 6 EA  
 FREE*

**SITE STRUCTURES**

10511 19th Ave SE, Suite C  
Everett, WA, (425)-357-9600

Project Normandy Hgts

sheet: 21  
date: 02-11-20  
prj. no. S-26-009

**Beam Design Below Grated Opening**

**Design Data**

Height of Curb:	1.5 ft
Curb Thickness:	6 in
Soil Density:	125 pcf
Beam Width:	12 in
Beam Span:	5 ft
Truck Rear Axle Load:	32 k

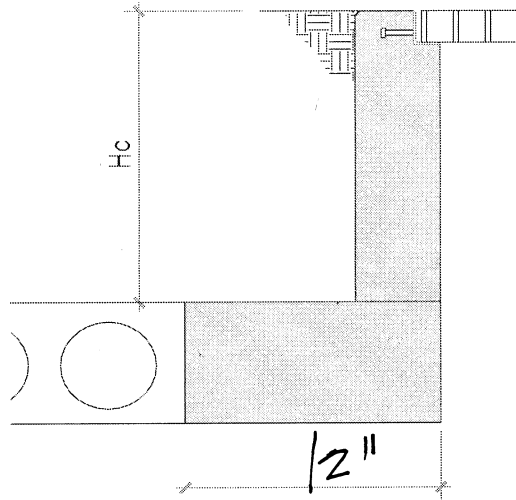

**Calculated Design Forces**

Soil Weight =	94 plf
Curb Weight =	113 plf
Self Weight =	156 plf
Wheel Load =	16000 lb

Load Factor:	DL 1.2
	LL 1.6

Wu =	435 plf
Pu =	25600 lb

**Design for Flexure**

Reinf Size	6
# of Top & Bot Reinf	3 ✓
Area of Steel	1.33 sq-in
Depth to Reinf (d)	10.13 in
Comp Block (a)	2.60 in
d - a/2	8.83 in

$\Phi Mn = 52636$  ft-lbs *ok*  $Mu = 33359$  ft-lbs

**Design for Shear**

Tie Reinf Size	4
Area of Steel	0.20
Depth to Reinf (d)	10.50
Max Spacing	5.25 in
Reinf Spacing	5 in

$\Phi Vc = 5866$  lbs

$\Phi Vs = 42057$  lbs

$\Phi Vc + \Phi Vs = 47923$  lbs *ok*  $Vu = 26688$  lbs

GRATING SELECTION

PER. LOADING 100 PSF - 9'-0" SPAN

SEE CHART ON FOLLOWING PAGE

1/4" x 3/16" BRD BARS 19-A GRATING

w/ 1/4" MAX DEFL 9'-0" MAX SPAN

CAPACITY MAX  
9'-0" SPAN

UNIFORM — 190 PSF  
CONCENTRATED - 935 lbs

SELECT 1/4" x 3/16" GRATING

## SELECTION GUIDE: 19-4 PLAIN SURFACE GRATING

For deflection of not more than 1/4" when subjected to the severest of the following: (1) the uniform loads below; (2) under concentrated mid-span loads of 300 lbs. up to 6'-0" span; or (3) 400 lbs. for spans 6'-0" and over.

SAFE UNIFORM LOAD LBS./SQ. FT.	3'-6"	4'-0"	4'-6"	5'-0"	5'-6"
50	1 x 1/8	1 x 1/8	1 x 3/16	1-1/4 x 1/8	1-1/4 x 3/16
75	1 x 1/8	1 x 1/8	1 x 3/16	1-1/4 x 1/8	1-1/4 x 3/16
100	1 x 1/8	1 x 1/8	1 x 3/16	1-1/4 x 1/8	1-1/4 x 3/16
125	1 x 1/8	1 x 1/8	1-1/4 x 1/8	1-1/4 x 3/16	1-1/2 x 1/8
150	1 x 1/8	1 x 3/16	1-1/4 x 1/8	1-1/4 x 3/16	1-1/2 x 3/16
200	1 x 1/8	1-1/4 x 1/8	1-1/4 x 3/16	1-1/2 x 3/16	1-3/4 x 3/16
300	1 x 3/16	1-1/4 x 3/16	1-1/2 x 3/16	1-3/4 x 3/16	2 x 3/16

SAFE UNIFORM LOAD LBS./SQ. FT.	6'-0"	6'-6"	7'-0"	8'-0"	9'-0"
50	1-1/2 x 3/16	1-3/4 x 3/16	1-3/4 x 3/16	2 x 3/16	2-1/4 x 3/16
75	1-1/2 x 3/16	1-3/4 x 3/16	1-3/4 x 3/16	2 x 3/16	2-1/4 x 3/16
100	1-1/2 x 3/16	1-3/4 x 3/16	1-3/4 x 3/16	2-1/4 x 3/16	2-1/2 x 3/16
125	1-1/2 x 3/16	1-3/4 x 3/16	2 x 3/16	2-1/4 x 3/16	-
150	1-3/4 x 3/16	1-3/4 x 3/16	2 x 3/16	2-1/2 x 3/16	-
200	1-3/4 x 3/16	2 x 3/16	2-1/4 x 3/16	-	-
300	2 x 3/16	2-1/4 x 3/16	2-1/2 x 3/16	-	-

GRATING ANCHORAGE REVIEW

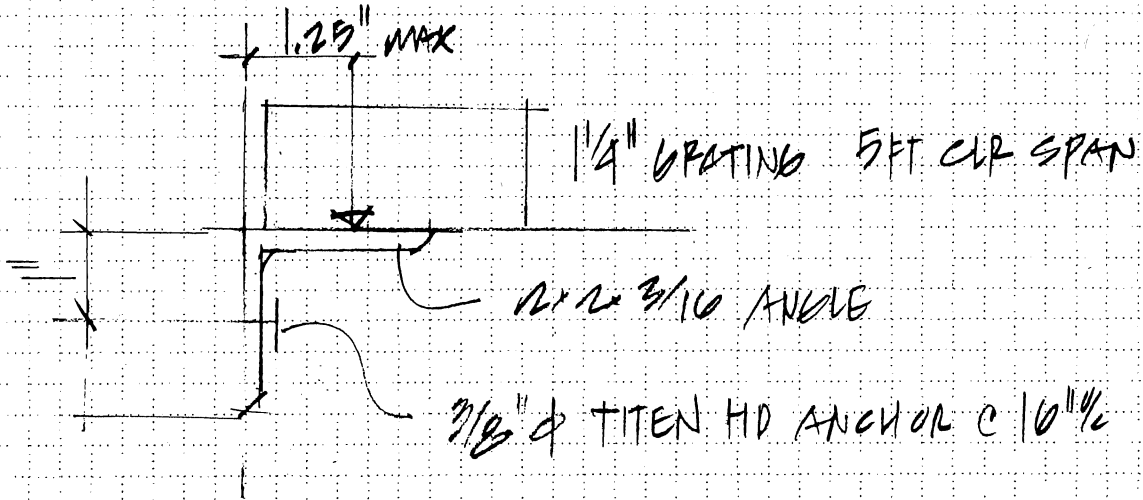

DESIGN  $U = 100$  PSF

$DL = 10$  PSF

LOAD TO EA ANCHOR

$2.9 (100) (1.25) = 362$  lbs

$2.9 (10) (1.25) = 36$  lbs

$V_u = 1.0 (362) + 1.2 (36) = 514$  lbs

$T_u = 514 (1.25 + 1.0) = 718$  lbs

$3/8$ "  $\phi$   $1/2$ " ANCHOR IS ACCEPTABLE - SEE  
SEE FOLLOWING SHEETS



Anchor Designer™  
Software  
Version 2.5.6163.1

SHEET #1  
07-11-26  
S-26-009

<Figure 2>

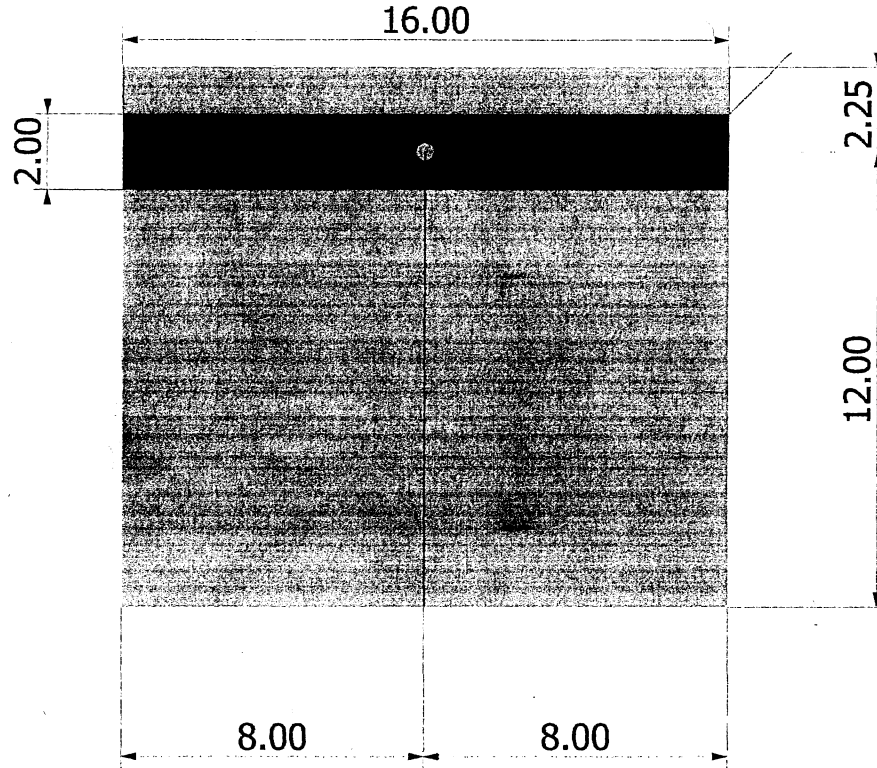

**Recommended Anchor**

Anchor Name: Titen HD® - 3/8"Ø Titen HD, hnom:3" (76mm)  
Code Report: ICC-ES ESR-2713





**Anchor Designer™**  
**Software**  
 Version 2.5.6163.1

SHEET 42  
02-11-26  
S-26-009

**1. Project information**

Customer company:  
 Customer contact name:  
 Customer e-mail:  
 Comment:

Project description:  
 Location:  
 Fastening description: Grating Ledger Angle attachment

**2. Input Data & Anchor Parameters**

**General**

Design method: ACI 318-14  
 Units: Imperial units

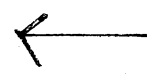

**Anchor Information:**

Anchor type: Concrete screw  
 Material: Carbon Steel  
 Diameter (inch): 0.375  
 Nominal Embedment depth (inch): 3.000  
 Effective Embedment depth,  $h_{ef}$  (inch): 2.190  
 Code report: ICC-ES ESR-2713  
 Anchor category: 1  
 Anchor ductility: No  
 $h_{min}$  (inch): 4.67  
 $c_{ac}$  (inch): 3.31  
 $c_{min}$  (inch): 1.75  
 $s_{min}$  (inch): 3.00

**Base Material**

Concrete: Normal-weight  
 Concrete thickness,  $h$  (inch): 6.00  
 State: Uncracked  
 Compressive strength,  $f_c$  (psi): 3000  
 $\Psi_{c,v}$ : 1.4  
 Reinforcement condition: B tension, B shear  
 Supplemental reinforcement: No  
 Reinforcement provided at corners: No  
 Do not evaluate concrete breakout in tension: No  
 Do not evaluate concrete breakout in shear: No  
 Ignore 6do requirement: Not applicable  
 Build-up grout pad: No

**Base Plate**

Length x Width x Thickness (inch): 2.00 x 16.00 x 0.19

**Load and Geometry**

Load factor source: ACI 318 Section 5.3  
 Load combination: not set  
 Seismic design: No  
 Anchors subjected to sustained tension: Not applicable  
 Apply entire shear load at front row: No  
 Anchors only resisting wind and/or seismic loads: No

<Figure 1>

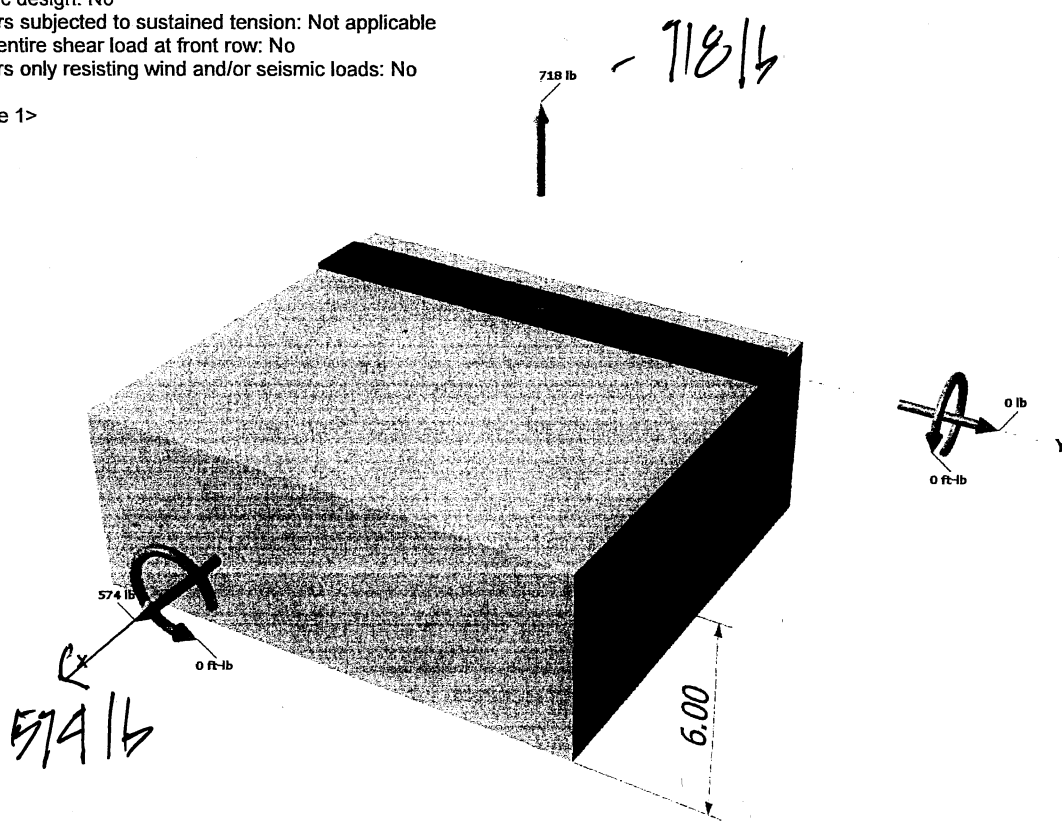



**3. Resulting Anchor Forces**

Anchor	Tension load, N <sub>ua</sub> (lb)	Shear load x, V <sub>uax</sub> (lb)	Shear load y, V <sub>uay</sub> (lb)	Shear load combined, $\sqrt{(V_{uax})^2 + (V_{uay})^2}$ (lb)
1	718.0	574.0	0.0	574.0
Sum	718.0	574.0	0.0	574.0

Maximum concrete compression strain (‰): 0.00  
 Maximum concrete compression stress (psi): 0  
 Resultant tension force (lb): 718  
 Resultant compression force (lb): 0  
 Eccentricity of resultant tension forces in x-axis, e'<sub>Nx</sub> (inch): 0.00  
 Eccentricity of resultant tension forces in y-axis, e'<sub>Ny</sub> (inch): 0.00  
 Eccentricity of resultant shear forces in x-axis, e'<sub>Vx</sub> (inch): 0.00  
 Eccentricity of resultant shear forces in y-axis, e'<sub>Vy</sub> (inch): 0.00

<Figure 3>

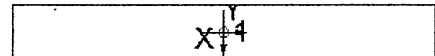

**4. Steel Strength of Anchor in Tension (Sec. 17.4.1)**

N <sub>sa</sub> (lb)	φ	φN <sub>sa</sub> (lb)
10890	0.65	7079

**5. Concrete Breakout Strength of Anchor in Tension (Sec. 17.4.2)**

$N_b = k_c \lambda_a \sqrt{f'_c} h_{ef}^{1.5}$  (Eq. 17.4.2.2a)

k <sub>c</sub>	λ <sub>a</sub>	f' <sub>c</sub> (psi)	h <sub>ef</sub> (in)	N <sub>b</sub> (lb)
24.0	1.00	3000	2.190	4260

$\phi N_{cb} = \phi (A_{Nc} / A_{Nco}) \Psi_{ed,N} \Psi_{c,N} \Psi_{cp,N} N_b$  (Sec. 17.3.1 & Eq. 17.4.2.1a)

A <sub>Nc</sub> (in <sup>2</sup> )	A <sub>Nco</sub> (in <sup>2</sup> )	c <sub>a,min</sub> (in)	Ψ <sub>ed,N</sub>	Ψ <sub>c,N</sub>	Ψ <sub>cp,N</sub>	N <sub>b</sub> (lb)	φ	φN <sub>cb</sub> (lb)
36.36	43.16	2.25	0.905	1.00	0.992	4260	0.65	2095

**6. Pullout Strength of Anchor in Tension (Sec. 17.4.3)**

$\phi N_{pn} = \phi \Psi_{c,P} \lambda_a N_p (f'_c / 2,500)^n$  (Sec. 17.3.1, Eq. 17.4.3.1 & Code Report)

Ψ <sub>c,P</sub>	λ <sub>a</sub>	N <sub>p</sub> (lb)	f' <sub>c</sub> (psi)	n	φ	φN <sub>pn</sub> (lb)
1.0	1.00	3879	3000	0.50	0.65	2762



**8. Steel Strength of Anchor in Shear (Sec. 17.5.1)**

$V_{sa}$ (lb)	$\phi_{grout}$	$\phi$	$\phi_{grout}\phi V_{sa}$ (lb)
4460	1.0	0.60	2676

**9. Concrete Breakout Strength of Anchor in Shear (Sec. 17.5.2)**

Shear perpendicular to edge in x-direction:

$V_{bx} = \min[7(l_e/d_a)^{0.2}d_a\lambda_a\sqrt{f_c}C_{a1}^{1.5}; 9\lambda_a\sqrt{f_c}C_{a1}^{1.5}]$  (Eq. 17.5.2.2a & Eq. 17.5.2.2b)

$l_e$ (in)	$d_a$ (in)	$\lambda_a$	$f_c$ (psi)	$C_{a1}$ (in)	$V_{bx}$ (lb)
2.19	0.375	1.00	3000	5.33	4116

$\phi V_{cbx} = \phi (A_{Vc}/A_{Vco})\Psi_{ed,V}\Psi_{c,V}\Psi_{h,V}V_{bx}$  (Sec. 17.3.1 & Eq. 17.5.2.1a)

$A_{Vc}$ (in <sup>2</sup> )	$A_{Vco}$ (in <sup>2</sup> )	$\Psi_{ed,V}$	$\Psi_{c,V}$	$\Psi_{h,V}$	$V_{bx}$ (lb)	$\phi$	$\phi V_{cbx}$ (lb)
96.00	128.00	1.000	1.400	1.155	4116	0.70	3493

Shear parallel to edge in x-direction:

$V_{by} = \min[7(l_e/d_a)^{0.2}d_a\lambda_a\sqrt{f_c}C_{a1}^{1.5}; 9\lambda_a\sqrt{f_c}C_{a1}^{1.5}]$  (Eq. 17.5.2.2a & Eq. 17.5.2.2b)

$l_e$ (in)	$d_a$ (in)	$\lambda_a$	$f_c$ (psi)	$C_{a1}$ (in)	$V_{by}$ (lb)
2.19	0.375	1.00	3000	8.00	7561

$\phi V_{cbx} = \phi (2)(A_{Vc}/A_{Vco})\Psi_{ed,V}\Psi_{c,V}\Psi_{h,V}V_{by}$  (Sec. 17.3.1, 17.5.2.1(c) & Eq. 17.5.2.1a)

$A_{Vc}$ (in <sup>2</sup> )	$A_{Vco}$ (in <sup>2</sup> )	$\Psi_{ed,V}$	$\Psi_{c,V}$	$\Psi_{h,V}$	$V_{by}$ (lb)	$\phi$	$\phi V_{cbx}$ (lb)
85.50	288.00	1.000	1.400	1.414	7561	0.70	6222

**10. Concrete Pryout Strength of Anchor in Shear (Sec. 17.5.3)**

$\phi V_{cp} = \phi K_{cp}N_{cb} = \phi K_{cp}(A_{Nc}/A_{Nco})\Psi_{ed,N}\Psi_{c,N}\Psi_{cp,N}N_b$  (Sec. 17.3.1 & Eq. 17.5.3.1a)

$K_{cp}$	$A_{Nc}$ (in <sup>2</sup> )	$A_{Nco}$ (in <sup>2</sup> )	$\Psi_{ed,N}$	$\Psi_{c,N}$	$\Psi_{cp,N}$	$N_b$ (lb)	$\phi$	$\phi V_{cp}$ (lb)
1.0	36.36	43.16	0.905	1.000	0.992	4260	0.70	2256

**11. Results**

**Interaction of Tensile and Shear Forces (Sec. 17.6)**

Tension	Factored Load, $N_{ua}$ (lb)	Design Strength, $\phi N_n$ (lb)	Ratio	Status
Steel	718	7079	0.10	Pass
Concrete breakout	718	2095	0.34	Pass (Governs)
Pullout	718	2762	0.26	Pass

Shear	Factored Load, $V_{ua}$ (lb)	Design Strength, $\phi V_n$ (lb)	Ratio	Status
Steel	574	2676	0.21	Pass
T Concrete breakout x+	574	3493	0.16	Pass
Concrete breakout y-	574	6222	0.09	Pass
Pryout	574	2256	0.25	Pass (Governs)

Interaction check	$N_{ua}/\phi N_n$	$V_{ua}/\phi V_n$	Combined Ratio	Permissible	Status
Sec. 17.6.3	0.34	0.25	59.7 %	1.2	Pass

ANCHOR OK  
K  
OK

3/8"Ø Titen HD, hnom:3" (76mm) meets the selected design criteria.

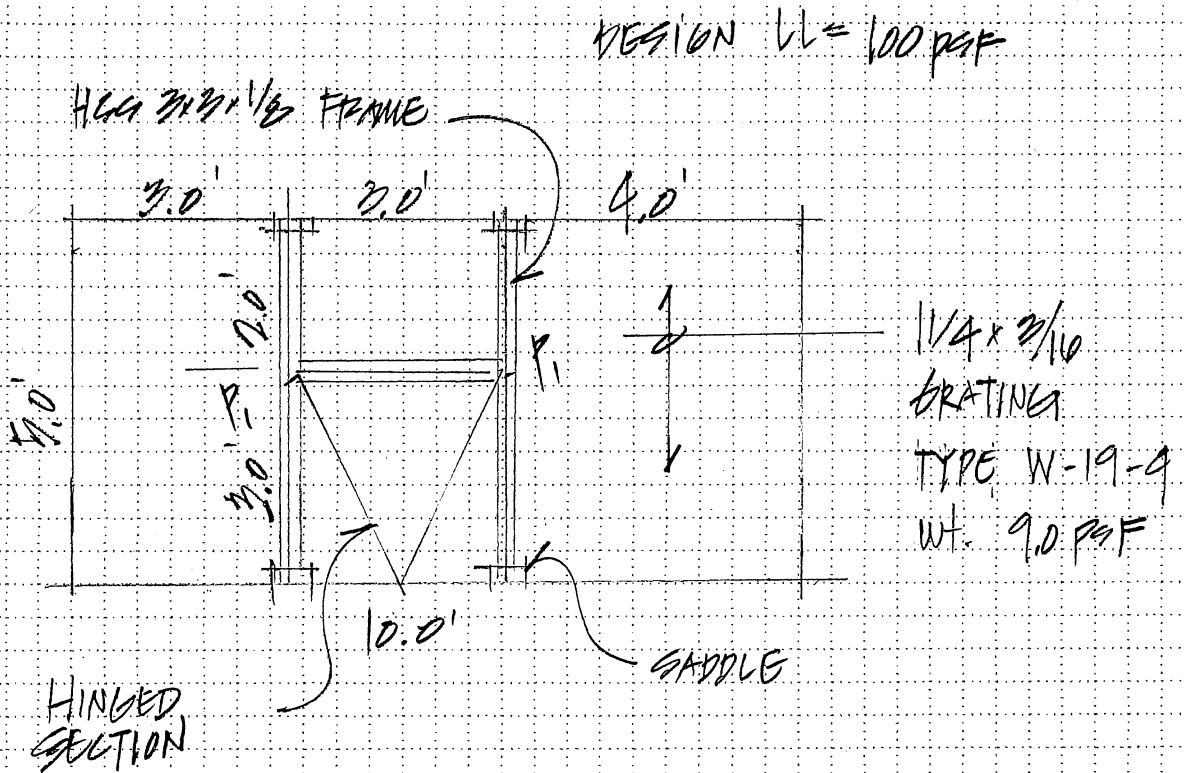

$$P_1 - \text{AREA TRID} = \left(\frac{3}{2}\right) \frac{5}{2} = 3.75 \text{ SQ FT} \quad P_{TU} = 413 \text{ LBS}$$

$$M = \frac{413(3)}{2} = 619.5 \text{ FT-LBS}$$

3x3x1/8 (0.120")  $I = 1.73$   $S = 1.19$  WT. 4.95 PLF

$$f_b = \frac{619.5(12)}{1.19} = 6200 \text{ PSI} < 20,000 \text{ PSI ALLOW}$$

$$\Delta_{TU} = \frac{413(3)^2(2+0) \sqrt{6(2)}}{27(2950)1.73(5)} = 0.03 \text{ IN OK}$$

$$R_{MAX} = 413(3/8) = 298 \text{ LBS}$$

1/2 x 3" TITEN HD ANCHOR  $V_{ALLOW} = 1500 \text{ LBS}$

4 ANCHORS PROVIDED @ BOT OF SEAT  $V_{ALLOW} = 6000 \text{ LBS OK}$

LATERAL STABILITY REVIEW

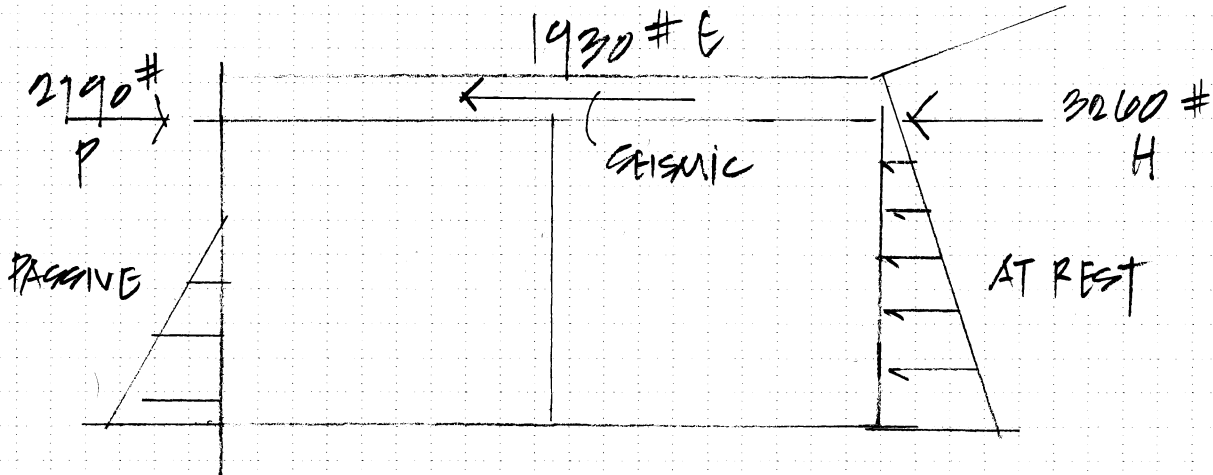

SEISMIC FORCE IN LID.

DL to LID SOIL + LID  $[1.5(125) + 90] 39 = 7660$   
 WALLS  $(175(2) + 125) 15.4/2 = 3080$   
 11340 lbs

$G_m = 0.833$   $R = 5.0$   $I = 1.0$

$R = 0.833 / 5 = 0.17$

$E = 11,340(0.17) = 1930 \text{ lbs}$

FACTORED LOAD TO LID DIAPHRAGM

$W_u = 1.0H + 1.0E - 1.0P$

$= 1.0(3060) + 1.0(1930) - 1.0(2790) = 4300\#$

LID REVIEW

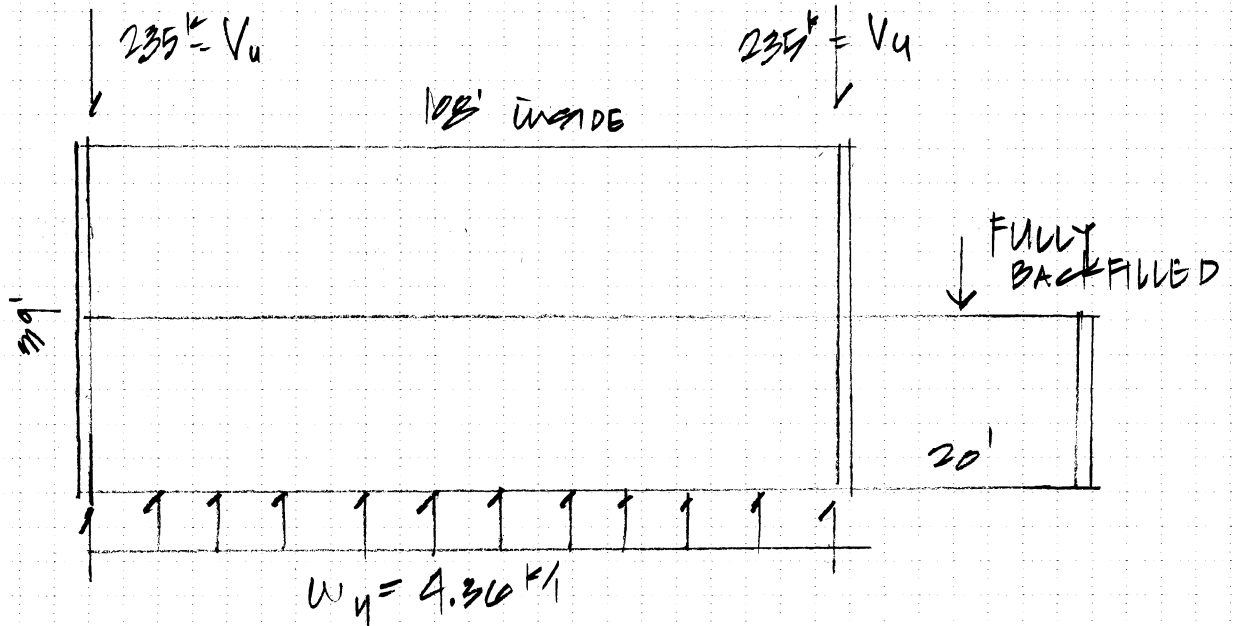

SHEAR TRANSFER TO WALLS

$$V_u = 235 \text{ k}$$

$$A_v f = 235 \div 0.60 (60) 1.0 = 6.92 \text{ in}^2$$

$A_v f$  PROVIDED

$$8 \text{ block outs w/ } (2) \#5 E = 4.96$$

$$2 \#5 \text{ C CENTER WALL} = 0.62$$

$$6 \#5 \text{ C PERIM WALLS} = 1.86$$

$$\underline{7.44 \text{ in}^2 \text{ ok}}$$

CHECK SHEAR @ A' FROM BWL

$$V_u = 239 - 4(4.36) = 218 \text{ k}$$

$$A_{vf} = 218 \div 0.60(60)1.0 = 6.0 \text{ in}^2$$

$A_{vf}$  PROVIDED

$$(2) \# 6 @ \text{ CENTER WALL} = 0.38$$

$$12 \# 6 @ \text{ PERIM WALLS} = \frac{5.28}{0.16 \text{ in}^2} \text{ ok}$$

MAX ALLOWABLE SHEAR IN FLANK

$$\phi V_n = \frac{80 \text{ psi} (12) (12)}{1000} = 450 \text{ k} \gg 239 \text{ k}$$

CHORD REINF @ EXPOSED WALL

$$M_u = 4.36(108)^2 \div 8 = 6357 \text{ k-ft}$$

$$A_c = 6357 \div 54(317) = 3.18 \text{ in}^2$$

$A_c$  PROVIDED

$$(6) \# 6 \text{ in CLOSURE} = 2.64$$

$$(4) \# 5 @ \text{ TOP OF WALL} = \frac{1.24}{3.88 \text{ in}^2} \text{ ok}$$

CHECK OVERTURNING ON BRACED WALLS

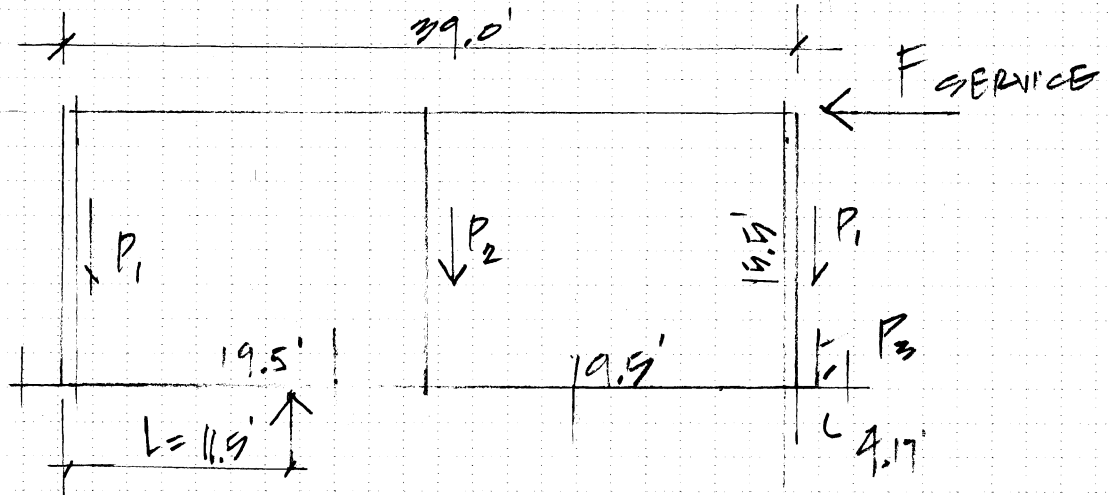

$$F_{SERVICE} = (1.0H + E/1.4 + 0.75P) \cdot 103/2 = 1728 \text{ k}$$

2540 #1

$$\text{OR } 235/1.5 = 150 \text{ k} \quad \text{USE } 100 \text{ k}$$

$$M_{OT} = 100(15.5) = 2480 \text{ k-ft}$$

MIN LOAD FROM PERP WALL USE EFF L = 10'

$$LID \text{ DL} = 278 \text{ psf}$$

$$P_1 = [278(19.5/2) + 175(19.5)] \cdot 10 = 87 \text{ k}$$

$$P_2 = [278(19.5) + 125(19.5)] \cdot 10 = 118 \text{ k}$$

$$\text{WALL DL} = 175(15.5) \cdot 39 = \frac{100 \text{ k}}{311 \text{ k}}$$

SOIL LOAD @ 4.17' FTG

$$P_3 = [18(125)4.17] \cdot 10 = 150 \text{ k}$$

CHECK PRO PRESSURE ≠ FTG WIDTH

$$X_{CW} = 311(19.9) \div \left( \frac{311 + 150}{400} \right) = 17.0'$$

$$ECC = 2450 \div 460 = 5.4' \text{ WITHIN MID THIRD}$$

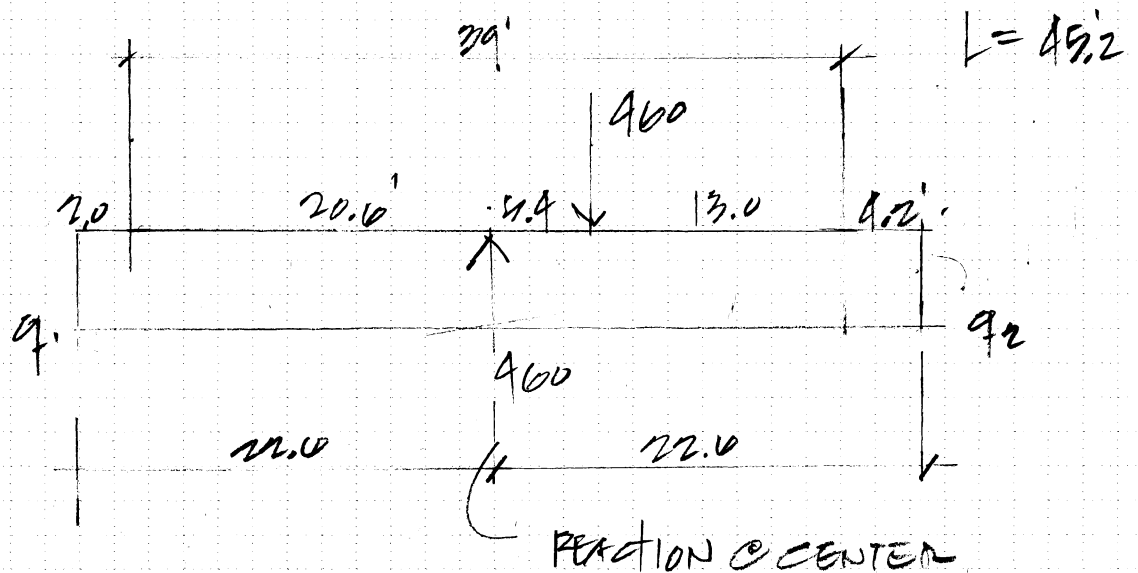

$$w = 460 \div 49.2 = 10.2 \text{ k/ft} \div 3.5 = 2.9'$$

USE 3.0' MIN

CHECK SHEAR CAPACITY OF WALL

14" THICK WALL #5 @ 15" @ HORZ EA FACE

$$\phi V_c = (0.6)^2 (0.003) 14 (29) 12 = 495 \text{ k} \gg 235 \text{ k OK}$$