

Bradley Heights Building J

206 27th Ave SE, BLDG J
Puyallup, WA 98374

Fire Alarm System Equipment Submittal

Date: 03/27/2026

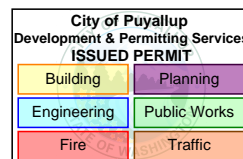

Kirby Electric Inc.

4826 B St NW. Ste. 101
Auburn, WA 98001
Phone (253) 859-2000
Fax (253)859-2363

6808

Addressable Fire Alarm Control Panel

The 6808 is an addressable fire alarm control panel (FACP) that is a direct replacement for the 5808 FACP. The 6808 can be configured to achieve a point capacity of 198 points. It has one built-in signaling line circuit (SLC), which can support 99 System Sensor® (SK) sensors and 99 SK modules or 127 Hochiki® (SD) devices per loop.

A common communications and annunciation link allows up to 17 panels to be connected via copper or fiber optic cable. A designated panel is configured as the communicator for all panels in the link for convenient single-point communications. It also has a built-in, dual-line POTS and IP communicator with additional cellular options available.

The 6808 system can be enhanced by adding modules such as the 6860 remote annunciator which also has four programmable function buttons to help automate tasks and reduce time spent at the panel.

SWIFT® wireless compatibility provides options for wireless detection through a Class A mesh network. It is ideal for hard-to-wire locations, buildings where new wiring is not allowed, or to provide an easy install fire system for new construction projects. SWIFT devices can be combined with other hard-wired 6808 compatible devices.

The 6808 also has a form-C trouble relay, two programmable form-C relays, along with powerful features such as drift compensation, pre-trouble maintenance alert, a built-in sensor test to comply with NFPA 72 calibration testing requirements, and calibration trouble alert.



6808

The supports a variety of devices, including the 6860, 5860, and 6855 remote annunciators, 5824 serial parallel printer interface module (for printing system reports), the 5496 NAC expander, 5895XL power module, and SK or SD devices.

FEATURES & BENEFITS

- Capable of providing up to 198 points to satisfy smaller installation needs
- Connect up to 17 panels on one site with convenient single-point access using the SK-NIC Network Interface Card. Connected panels can have mixed compatible FACP models
- Convenient field-upgradeable firmware
- Built-in dual path POTS and IP communications with optional cellular models available for reliable backup reporting
- 6860 annunciator with a 4 x 40 large display
- Four user-programmable buttons minimize time spent executing complex or routine tasks
- Built-in USB interface for convenient and quick programming
- Programmable date setting for automatic and convenient Daylight Saving Time changes
- JumpStart® auto programming reduces installation time
- 125 software zones and 125 output groups for flexible design options

SIGNAL LINE CIRCUIT (SLC)

The 6808 SLC loop supports multiple device types, maintenance alerts, and a built-in sensor test to comply with NFPA 72 calibration testing requirements.

INDICATOR LIGHTS

- **General Alarm (Red):** Flashes if in alarm; solid when alarm is silenced
- **Supervisory (Yellow):** Flashes if a supervisory condition exists; solid when supervisory is silenced
- **System Troubles (Yellow):** Flashes if a trouble condition exists; solid when trouble is silenced
- **System Silenced (Yellow):** On when an alarm, trouble or supervisory condition has been silenced but not yet cleared
- **System Power (Green):** Flashes for AC failure; solid when power systems are normal

USER INTERFACE

The 6808 built-in 4 x 20 annunciator with 80 character LCD display and large easy-to-use tactile touchpad can be used for system operation, programming and maintenance. It has five LEDs for alarm, supervisory, system trouble, system silenced and system power.

System operations include silencing alarms and troubles, resetting alarms and the display of alarm troubles and memory. The system's non-volatile event history buffer stores 1,000 events for viewing from the built-in or remote annunciator. System operations can be initiated with a mechanical firefighter's key or a valid 4- to 7-digit operator's code.

PROGRAMMING

The 6808 system offers several options to simplify and speed-up programming. JumpStart® auto programming minimizes programming required to start a new system. The built-in keypad, or the 6860, 5860 or 6855 remote annunciators give you on-site access to current system programming. Programming can also be accomplished using the Windows®-based Honeywell Fire Software Suite (HFSS) program.

SOFTWARE TOOLS

SKST: Silent Knight Selection Tool provides the installer or design architect with a Windows® software system configuration tool to create a detailed Bill of Material (BOM) and battery calculations.

HFSS: Honeywell Fire Software Suite provides communication and panel programming, detector status, event history and additional data. Requires a PC running Microsoft® Windows®.

ADDITIONAL INFORMATION

Twisted-unshielded pair wire is recommended.

The 6808 also has 13 preset notification cadence patterns (including ANSI 3.41).

AGENCY LISTINGS AND APPROVALS

NPFA 13, NFPA 15, NFPA 16, NFPA 70, NFPA 72: Central station; remote Signaling; Local Protective Signaling Systems; Auxiliary Protected Premises Unit; Water Deluge releasing service. Suitable for automatic, manual, waterflow, sprinkler supervisory (DACT non-coded) signaling services

- **UL Listed:** S2766
- **CSFM:** 7165-0559:0502
- **FDNY:** COA# 6246
- **FM approved**

ORDERING INFORMATION

6808: Addressable Fire Alarm Control Panel. (Red cabinet).

COMPATIBLE ANNUNCIATORS

6860: 4x40 LCD remote fire annunciator (4 lines and up to 160 characters) per system; four programmable buttons

5860: 4x20 LCD remote fire annunciator. 5860 is gray; 5860R is red

6855: 4x20 LCD remote fire annunciator

5865-3 or 5865-4: LED annunciators can display up to 30 LEDs (15 red and 15 yellow). The 5865-4 has key switches for silence and reset, and a system trouble LED.

5880: LED / IO module has 40 programmable LED outputs and eight supervised dry contact inputs which are useful for custom applications. You can use up to eight 5880 modules on one control panel for maximum flexibility. Its compact size allows mounting inside the annunciator, or in an accessory cabinet.

6808 COMPATIBLE DEVICES AND ACCESSORIES

See the data sheets listed below for a complete listing of the SK, SD or SWIFT devices.

53623: SK Devices Data Sheet

53624: SD Devices Data Sheet

350614, 350616 & 350618: SWIFT wireless devices

For a complete and current listing of compatible devices and accessories, visit www.silentknight.com.

Important: You cannot mix SK and SD devices in the same fire alarm system.

SK COMPATIBLE ADDRESSABLE DEVICES

SK-ACCLIMATE: Multi criteria photoelectric smoke detector with thermal 135°F fixed temperature
SK-BEAM: Reflected beam smoke detector without test feature
SK-BEAM-T: Reflected beam smoke detector with test feature
SK-CONTROL: Supervised control module
SK-CONTROL-6: Six circuit supervised control module
SK-DUCT: Photoelectric duct smoke detector with extended air speed range
SK-FIRE-CO: Four criteria fire and carbon monoxide detector
SK-HEAT: Fixed thermal detector (135°F)
SK-HEAT-W: Fixed thermal detector (135°F), white
SK-HEAT-ROR: Fixed rate of rise detector (135°F)
SK-HEAT-ROR-W: Fixed rate of rise detector (135°F), white
SK-HEAT-HT: Fixed high temperature thermal detector (190°F)
SK-HEAT-HT-W: Fixed high temperature thermal detector (190°F), white
SK-ISO: Fault isolator module
SK-MINIMON: Mini monitor module
SK-MONITOR: Monitor module
SK-MONITOR-2: Dual input monitor module
SK-MON-10: 10 input monitor module
SK-PHOTO: Photoelectric smoke detector
SK-PHOTO-W: Photoelectric smoke detector, white
SK-PHOTO-T: Photoelectric smoke detector with thermal (135°F fixed temperature)
SK-PHOTO-T-W: Photoelectric smoke detector with thermal (135°F fixed temperature), white
SK-PHOTOR: Photoelectric detector with remote test capability
SK-PHOTO-R-W: Photoelectric detector with remote test capability, white
SK-PULL-SA: Addressable single action pull station
SK-PULL-DA: Addressable dual action pull station
SK-RELAY: Addressable relay module
SK-RELAY-6: Addressable Six relay control module
SK-RELAYMON-2: Addressable Dual relay/monitor module
SK-ZONE: Addressable zone interface module
SK-ZONE-6: Six zone interface module
B300-6(-IV): 6" base for SK-W Series
B210LP: 6" mounting base
B501(-BL,-IV,-WHITE): 4" flangeless base
B501: 4" Flangeless mounting base
B200S(-IV,-WH): Intelligent sounder base
B200S: Intelligent sounder base

B200S-LF(-IV,-WH): Low-Frequency intelligent sounder base
B200S-LF: Low-frequency intelligent sounder base
B224RB(-IV,-WH): Relay base
B224RB: Relay base
B224BI(-IV,-WH): Isolator base
B224BI: Isolator base

SD COMPATIBLE ADDRESSABLE DEVICES

SD505-6AB: Addressable 6" base
SD505-6IB: Addressable 6" short circuit isolator base
SD505-6RB: Addressable 6" relay base
SD505-6SB: Addressable 6" sounder base
SD500-AIM: Addressable input module (switch input)
SD500-ANM: Addressable notification module
SD500-ARM: Addressable relay module
SD505-DTS-K: Remote test switch and LED indicator for the SD505-DUCTR
SD505-DUCT: Addressable Duct Smoke Detector.
SD505-DUCTR: Addressable Duct Detector housing with relay base.
SD505-HEAT: Absolute temperature heat detector. Trip point range from 135°F–150°F (0°C–37°C).
SD500-LIM: Addressable Line isolator module
SD500-MIM: Addressable Mini input monitor module (switch input)
SD505-PHOTO: Photoelectric smoke detector
SD500-PS/-PSDA: Addressable Single or dual action pull station
SD500-SDM: Addressable smoke detector module

AUDIBLE/VISIBLE DEVICES

These AV devices are all 2-wire. Color: "R" indicates red; "W" denotes white. For a complete listing of Silent Knight AV devices go to www.silentknight.com.
CHSRL/CHSWL: Wall chime/strobe
CHSRL/CHSCWL: Ceiling chime/strobe
CHRL/CHWL: Wall chime
HRL/HWL: Wall horn
P2RL/P2WL: Wall horn/strobe
PC2RL/PC2WL: Ceiling horn/strobe
SRL/SWL: Wall strobe
SCRL/SCWL: Ceiling strobe
SPSRL/SPSCWL: Ceiling speaker/strobe
SPSRL/SPSWL: Wall speaker/strobe
SPRL/SPWL: Wall speaker
SPCRL/SPCWL: Ceiling speaker

SWIFT WIRELESS DEVICES

SWIFT is only compatible with System Sensor (SK) devices. It is not compatible with Hochiki (SD) devices.

WSK-WGI: Wireless Gateway
WSK-PHOTO: Wireless Photoelectric smoke detector
WSK-PHOTO-T: Wireless Multi-criteria photoelectric smoke detector with thermal detection (135°F fixed temperature) and B510W 4" base
WSK-HEAT: Wireless Heat, (135°F fixed temperature) and B510W 4" base
WSK-HEAT-ROR: Wireless heat, ROR (135°F fixed temperature) and B510W 4" base
WSK-MONITOR: Wireless monitor module
WSK-RELAY: Wireless relay module
W-USB: SWIFT Tools USB transceiver used for communication with SWIFT devices

SBUS ACCESSORIES

5496: A 6 amp notification power expander with four power-limited notification appliance circuit outputs.
5883: Relay Interface. Provides 10 Form C relays.
5824: Serial/Parallel Printer Interface Module for printer connection.
5895XL: Power Supply with six Flexput™ circuits, and two Form C relays. Max. 16 per system.
5815RMK: Remote mounting kit. Dimensions: 10 3/8"W x 10-3/16"H x 3"D

COMMUNICATION OPTIONS

CELL-CAB-SK: Cellular communicator, metal enclosure with lock/key*
CELL-MOD: Cellular communicator, plastic enclosure*
*Sole path, powered by panel.
IPGSM-4G: Dual path fire alarm communicator, cellular and/or IP (primary or backup, selectable)
SK-IP-2: Remote reporting via the Internet. Requires a VisorAlarm® receiver at the central station

MISC. ACCESSORIES

SK-NIC: Network Interface Card. Provides a common communications link for the 6808.
SK-NIC-KIT: Installation Accessory Kit
SK-FML: Fiber-Optic Multi Mode, transmitter and receiver
SK-FSL: Fiber-Optic Single Mode
RBB: Remote battery box accessory cabinet for batteries that are too large to fit in the FACP cabinet. Dimensions: 16" W x 10" H x 6" D (406mm W x 254mm H x 152mm D).
SK-SCK: Seismic Compliance Kit used to securely fasten batteries to the fire panel.

6808 Technical Specifications

PHYSICAL

Overall Dimensions: 16.36"W x 26.37"H x 3.91"D

Shipping Weight: 32 lbs.

Color: Red

ENVIRONMENTAL

Operating Temperature: 32°F to 120°F (0°C to 49°C)

Humidity: 0 to 93% relative humidity (non-condensing)

ELECTRICAL

6808 Primary AC: 120 VAC @ 60Hz, 3.3A Total

Accessory Load: 6A @ 27.4VDC power-limited

Standby Current: 190mA

Alarm Current: 250mA

Battery Charging Capacity: 7 to 35AH

Battery Size: 7AH to 18AH max. allowed in control panel cabinet. Larger capacity batteries can be housed in RBB accessory cabinet.

NOTIFICATION APPLIANCE CIRCUITS (NACs)

Four programmable circuits which can be programmed individually as:

NACs: 3A @ 27.4VDC per circuit, power-limited (with a maximum current of 6A)

Auxiliary Power Circuits: 3A @ 27.4VDC per circuit, power-limited

Supports Class B (Style 4) and Class A (Style 6 or 7) configuration for the SLC

WIRING: See the product manual for wiring details

Flexput®, Honeywell®, JumpStart®, Silent Knight®, SWIFT®, and System Sensor® are registered trademarks of Honeywell International Inc.

Hochiki® is a registered trademark of Hochiki Corporation. Microsoft® and Windows® are registered trademarks of Microsoft Corporation.

This document is not intended to be used for installation purposes. We try to keep our product information up-to-date and accurate. We cannot cover all specific applications or anticipate all requirements. All specifications are subject to change without notice.

For Technical Support, call 800-446-6444.

Honeywell Silent Knight

12 Clintonville Road
Northford, CT 06472
800-328-0103

351608 | B | 09/18
© 2018 Honeywell International Inc.



HPF-PS6/HPF-PS10 Series 6/10 Amp, 24 Volt Power Supplies

General

The HPF-PS Series is a remote power supply line from Honeywell and is a direct replacement for the PSE and FCPS Series. The HPF-PS6(B)(E) is a 6 amp and the HPF-PS10(B)(E) is a 10 amp, remote power supply with battery charger that may be connected to any 12 or 24 volt fire alarm control panel (FACP) or used as a stand-alone power supply. The HPF-PS Series provides 24 VDC power for NACs (notification appliance circuits) configured as either Class B or Class A (requires the ZNAC-PS option card) with multiple sync protocol options. The HPF-PS Series also provides auxiliary power, constant or resettable, suited for detectors, annunciators, door holders, and other fire alarm system peripherals. The HPF-PS Series cabinet can hold two 7 AH or 18 AH batteries and can charge up to 33 AH batteries in a separate cabinet. The HPF-PS6E and HPF-PS10E are models rated for 240V operation.

Features

- Up to five (6 amp model) or seven (10 amp model) independently-configurable, power-limited output circuits for:
 - Class B and/or Class A NACs
 - Class B and/or Class A resettable or non-resettable 24V auxiliary power
 - door holder power
- Converts from Class B to Class A wiring without losing any outputs using the ZNAC-PS converter card (sold separately)
- Optimal for powering four-wire smoke detectors, annunciators, and other system peripherals requiring regulated power
- Configurable for ANSI® Temporal 3 or Temporal 4 coded output
- UL-Listed NAC synchronization using System Sensor®, Wheelock®, Gentex®, or AMSECO® appliances
- Synchronization can be triggered from FACP NAC/remote sync outputs, cascaded power supply, or a control module, single or multi, which may be housed within the power supply cabinet
- Ability to cascade up to four power supplies
- Two (6 amp model) or three (10 amp model) fully-isolated input/control circuits which can be programmed to any output
- Two Form C normally-closed trouble relays for AC Trouble and General Trouble, Ground Fault relay available on Canadian models only
- 6 or 10 amp full load output, respectively, with 3 A maximum/circuit
- Individual NAC power and trouble LEDs for diagnostic efficiency
- Trouble history modes for diagnostic support
- Wide range end-of-line supervision value (normal: 2K-27K ohms)
- Selectable earth fault detection (enable or disable)
- AC trouble report delay timer
- Completely configurable via onboard DIP switches, no extra software required
- Self-contained in compact, locking cabinet constructed of heavy gauge steel with a corrosion-resistant powder coat chip and scratch-resistant finish
- Cabinet designed with ten double knockouts and a removable door for ease of installation and wiring
- Includes integral battery charger capable of charging up to 33 AH batteries
- Cabinet can house two 7 AH or 18 AH batteries

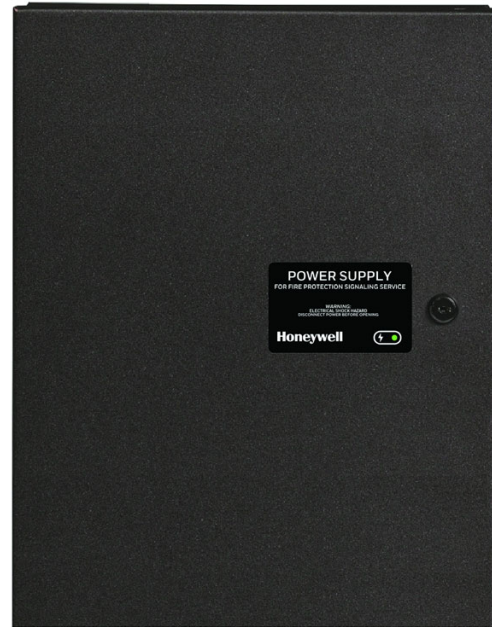

- Battery charger may be disabled via DIP switch for applications requiring larger batteries and external battery charger
- Removable terminal blocks accommodate up to 12 AWG (3.1mm²) wire
- Works with any UL 864 FACP which utilizes an industry-standard reverse-polarity notification circuit
- Optional devices include addressable control, monitor, and relay modules and power-supervision relay (EOLR-1)

Standards and Codes

The HPF-PS Series comply with the following standards:

- **NFPA 72** National Fire Alarm Code
- **UL 864** Standard for Control Units for Fire Alarm Systems (NAC expander mode), 10th Edition
- **UL 1481** Power Supplies for Fire Alarm Systems
- **IBC 2009** (when using SEISKIT-MULTI-1)
- **CBC 2007** (when using SEISKIT-MULTI-1)

Agency Listings and Approvals

These listings and approvals apply to the modules specified in this document. In some cases, certain modules or applications may not be listed by certain approval agencies, or listing may be in process. Consult factory for latest listing status.

- **UL Listed:** S24562 (HPF-PS/E Series), S635, S674 (PSE Series, discontinued)
- **ULC Listed:** S24562 (HPF-PS Series), S635 (PSE-6C/PSE-10C discontinued)
- **CSFM Approved:** 7315-1637:0505 (HPF-PS Series), 7315-0028:0513 (PSE Series, discontinued)
- **FDNY COA:** 2022-TMCOAP-002231-AMND (HPF-PS Series), 2021-TMCOAP-001761-CERT (PSE Series, discontinued)
- **FM Approved**

Primary (AC) Power:

- **HPF-PS6(B):** 120 VAC, 50/60 Hz, 5.0A maximum
- **HPF-PS10(B):** 120VAC, 50/60 Hz, 6.2 A maximum
- **HPF-PS6E:** 240 VAC, 50/60 Hz, 2.7A maximum
- **HPF-PS10E:** 240 VAC, 50/60 Hz, 3.5A maximum
- **Wire Size:** #12-14 AWG with 600 V insulation

Command Input Circuit:

- **Trigger Input Voltage:** 9 to 32 VDC
- **Trigger Current:** 2.0 mA (16 - 32 V); Per Input: 1.0 mA (9 - 16 V)

Trouble Contact Rating: 4 A at 24 VDC

Output Circuits:

- 24 VDC filtered, regulated
- HPF-PS6(B): TB8-TB9 – 1A Regulated, 3A special applications; TB10-TB12 – 0.3A Regulated, 3A special applications
- HPF-PS10(B): TB8-TB11 – 1.5A Regulated, 3A special applications; TB12-TB14 – 0.3A Regulated, 3A special applications
- 6.0 A (HPF-PS6) or 10.0 A (HPF-PS10) maximum total continuous current for all outputs

Secondary Power (Battery) Charging Circuit:

- Supports lead-acid batteries only
- Float-charge voltage: 27.6 VDC
- Maximum current charge: 1.5 A
- Maximum battery capacity: 18 AH (inside cabinet)
- Maximum battery charging capacity: 33 AH (external cabinet)

Physical:

- **Dimensions:** 20.0"H x 14.5"W x 3.5"D (cm: 50.8H x 36.83W x 8.9D)
- **Weight:** with two 7Ah batteries is 24 pounds (10.9 kg), with two 18 AH batteries is 39 pounds (17.7 kg)

Ordering Information

HPF-PS6: 6.0 A, 120 VAC remote charger power supply in a lockable, metal enclosure, red

HPF-PS6B: 6.0 A, 120 VAC remote charger power supply in a lockable, metal enclosure, black

HPF-PS6E: 6.0 A, 240 VAC remote charger power supply in a lockable, metal enclosure, red

HPF-PS10: 10.0 A, 120 VAC remote charger power supply in a lockable, metal enclosure, red

HPF-PS10B: 10.0 A, 120 VAC remote charger power supply in a lockable, metal enclosure, black

HPF-PS10E: 10.0 A, 240 VAC remote charger power supply in a lockable, metal enclosure, red

ZNAC-PS: Optional Class A output converter module

50152254-001: Hardware kit for Canadian applications

17045: Alternate NOTIFIER lock set

FCM-1: Addressable Control Module for one Class B or Class A zone of supervised, polarized Notification Appliances. Notification Appliance Circuit option requires external 24 VDC to power notification appliances.

FRM-1: Addressable relay module containing two isolated sets of Form-C contacts, which operate as a DPDT switch

FMM-1: Addressable Monitor Module for one zone of normally open dry-contact initiating devices. Includes plastic cover plate and end-of-line resistor. Module may be configured for either a Class B or Class A IDC.

FDM-1: Dual Monitor Module. Same as FMM-1 except it provides two inputs for Class B wiring only

FDRM-1: Provides two monitored inputs and two Form-C relays. Functions in Class B wiring only.

XP6-C: Six-circuit supervised control module

XP6-R: Six Form-C relay control module

EOLR-1: 12/24 VDC end-of-line relay for monitoring four-wire smoke detector power

BAT-1270-BP: Battery, 12 volt, 7.0 AH, 5-pack (two required, see BAT Series data sheet DN-6933).

BAT-12180-BP: Battery, 12 volt, 18AH, 2-pack

BAT-12330: Battery, 12 volt, 33AH

SEISKIT-MULTI-1: Seismic kit for the HPF-PS Series. Includes bracket and hardware for two 7AH or two 18AH batteries.



This document is not intended to be used for installation purposes.

We try to keep our product information up-to-date and accurate.

We cannot cover all specific applications or anticipate all requirements.

All specifications are subject to change without notice.

NOTIFIER® and System Sensor® are registered trademarks of Honeywell International, Inc. Wheelock® is a registered trademark of Cooper Technologies Company. Gentex® is a registered trademark of Gentex Corporation. AMSECO® is a registered trademark of Potter Electric Signal Company, LLC. ANSI® is a registered trademark of the American National Standards Institute, Inc.

©2023 by Honeywell International Inc. All rights reserved. Unauthorized use of this document is strictly prohibited.

Country of Origin: USA

NOTIFIER

12 Clintonville Road
Northford, CT 06472
203.484.7161
www.notifier.com



HW-AV-LTE-M CLSS PATHWAY

Connected Life Safety Services (CLSS) Dual-Path LTE Communicator with Dialer Capture Interface

The Honeywell® CLSS Pathway is a differentiated communications platform with dual SIM support for AT&T® and Verizon® and integrated features powered by the CLSS Cloud.

The CLSS Pathway combines dialer capture functionality with the powerful capabilities of Honeywell's CLSS Cloud. It represents the latest alarm communications technology for the fire industry. CLSS Pathway, an UL864 listed communicator allows data transfer from alarm systems at remote sites to any Central Monitoring Station and CLSS Cloud using LTE CAT-M1 network and LAN.

This device provides a single site-to-cloud path ensuring all CLSS Cloud services use the same audited and monitored method to access the on-premise life safety system.

HONEYWELL CONNECTED LIFE SAFETY SERVICES (CLSS)

Honeywell CLSS is an innovative, all-in-one cloud platform that enables systems integrators and facilities managers to deliver an enhanced fire safety service, while maximizing the performance efficiencies offered by Honeywell's trusted detection and alarm systems. The CLSS platform enables users to:

- Transmit Fire Alarm Control Panel events to Central Monitoring Station
- Get a "bird's eye" view of all accounts
- Obtain real-time information on event generation, enabling diagnosis before dispatch
- Conduct tests and inspections using a mobile app (available in select markets)
- Provide end users with multi-site asset information and event alerts
- Support contextual information for First Responders (available in select markets)

DUAL AT&T AND VERIZON SUPPORT

Equipped with dual SIM cards, the CLSS Pathway supports both AT&T and Verizon networks. When first powered on, the communicator connects through the primary cellular network (Verizon). If primary cellular pathway is not available, the device connects through the secondary cellular network (AT&T). Supports option to change the default primary cellular network from Verizon to AT&T using CLSS Mobile App or CLSS Site Manager.

SIMPLIFIED INSTALLATION

The CLSS Pathway is commissioned via the CLSS mobile app and CLSS Site Manager interface, which also allow for additional remote visibility.

Connection and mounting is simplified using the enclosure kit. The CLSS Pathway is compatible with any fire alarm dialer using Contact ID, SIA, or 4x2 format and automatically recognizes the format when powered up. Any number can be programmed into the panel phone numbers. Installers can select the central station service they wish to use from a list of approved central station providers. Only account numbers assigned by the central station must be programmed and the dialer selected for tone dialing output.

FEATURES AND BENEFITS

- CLSS enables monitoring of event transmission data & management of device inventory from the CLSS mobile app and web portal (available only when using point-based reporting)
- Meets UL864 requirements for Sole and Dual Path communications. Supports sole path communication leveraging redundant cell carriers (dual-SIM, Verizon, or AT&T) or a dual-path communication using IP as the primary path and redundant cellular carriers as the secondary path
- CLSS mobile app supports push and email notifications
- Remote firmware updates
- High reliability due to multiple transmission channels (LTE CAT-M1/LAN) and redundant servers
- Universal Panel Compatibility - Dialer capture interface supporting Contact ID, SIA or 4x2. (Supported SIA formats - SIA8, SIA20, SIA2000. Supported 4x2 frequencies - 1400 Hz, 2300 Hz)
- Unique "M1" Network is 5G ready, providing deep signal penetration that allows operation within buildings
- Four supervised inputs for non-dialer panels
- Exceptional Redundancy - Dual-SIM device. If one network becomes unavailable, the communicator connects to the other network
- Powered directly by a 24-volt DC fire alarm power supply. No need for additional batteries, transformer, or power supply
- Connection monitoring - adjustable fault reporting time
- Web-based software and smartphone app for device configuration and administration



Metal enclosure (HW-AV-ENC) for housing CLSS Pathway (HW-AV-LTE-M)



CLSS Pathway (HW-AV-LTE-M)

HW-AV-LTE-M TECHNICAL SPECIFICATIONS

Characteristics	Imperial Unit	Metric Unit
Electrical		
Supply Voltage	+12 to +29 VDC	
Power Consumption	<ul style="list-style-type: none">Standby: 60 mAPeak: 200 mA	
Frequency	LTE CAT-M1 700/850/1700/1900/2100 MHz	
Environment		
Operating Temperature	32°F to 120°F	0°C to 49°C
Relative humidity:	1% to 85% Non-condensing	
Physical		
Dimensions	3.54" L x 2.48" W x 1.26" D	90 mm L x 63 mm W x 32 mm D
Weight (without antenna)	2.56 oz	72.57 gm
RoHS	Yes	
Network Providers		
<ul style="list-style-type: none">AT&T, North AmericaVerizon, North AmericaOther provider in the area networks		

AGENCY LISTINGS AND APPROVALS

The listings and approvals below apply to the HW-AV-LTE-M Communicator. In some cases, certain modules may not be listed by certain approval agencies, or listing may be in process. Contact Honeywell for the latest listings.

- **UL Listed for UL864 Standard:** S35608
(Note: Check for UL receiver compatibility with Central Station)
- **ETL Listed for UL864 & UL1610 Standard:** 5013005
- **FCC**
- **CSFM:** 7300-1637: 0511
- **FDNY:** 2022-TMCOAP-001312-CERT
- **LAFD**

STANDARDS AND CODES

National Fire Protection Association:

- NFPA 70
- NFPA 72

Honeywell International, Inc.

www.fire.honeywell.com

ORDERING INFORMATION

- **HW-AV-LTE-M-2:** CLSS Pathway, Fire Alarm Dual Path Communicator, LTE Dual SIM, includes antenna, ETL & UL Listed HW-AV-LTE-M.
- **HW-AV-ENC:** Enclosure for the CLSS Pathway (HW-AV-LTE-M)

CUSTOMER SUPPLIED EQUIPMENT

Mobile Device for LTE Communicator configuration (either iOS or Android).

Android™ is a trademark of Google, Inc.

AT&T® is a registered trademark of the AT&T Properties, L.P.

Honeywell® is a registered trademark of Honeywell International, Inc.

iOS® is a registered trademark of Cisco Systems Inc. licensed by Apple Inc.

Verizon® is a registered trademark of Verizon Trademark Services LLC.

This document is not intended to be used for installation purposes. We try to keep our product information up-to-date and accurate. We cannot cover all specific applications or anticipate all requirements. All specifications are subject to change without notice.

THE
FUTURE
IS
WHAT
WE
MAKE IT

Honeywell

Honeywell



SK-PULL-SA / SK-PULL-DA

Intelligent Pull Stations

The SK-PULL-SA is a single action pull station requiring only one motion to activate the station. The SK-PULL-DA is a dual action pull station requiring two motions to activate the station. The SK-PULL-SA and SK-PULL-DA are for use with Honeywell Silent Knight Series fire control panel (FACP).

Extremely easy to operate, the SK-PULL-DA and SK-PULL-SA provide a fast and practical means of manually initiating a fire alarm signal. The FACP recognizes each manual pull station by its specific address saving precious seconds in determining the location of an alarm.

INSTALLATION

The SK-PULL-SA and SK-PULL-DA can be surface mounted to an SB-I/O surface back box or semi-flush mounted on a standard single-gang with a minimum depth of 2.13"(5.40 cm) or double gang or 4" (10.61 cm) square electrical box. You can also use the optional (System Sensor® PN BG-TR) trim ring if the station is being semi-flush mounted.



SK-PULL-SA



SK-PULL-DA

FEATURES & BENEFITS

- Installer can open station without causing an alarm condition
- Dual-color LED is visible through handle of station blinks green to indicate normal operation and remains steady red in an alarm condition
- Key operated test and reset lock using lock plate actuator
- Key matches compatible FACP locks
- Meets ADA requirement for 5 lbs maximum pull force to active
- Meets the Americans with Disabilities Act Accessibility Guidelines (ADAAG) controls and operating mechanisms guidelines (Section 4.1.3[13])
- Shell, door, and handle molded from durable LEXAN®
- Reliable analog communications for trouble-free operation
- Braille text on station handle
- Rotary address switches for fast installation
- Handle latches in down position and the word Activated appears, clearly indicating the station has been pulled
- UL Listed, including UL 38, Standard of Manually Actuated Signaling System
- CSFM Listed
- MEA Listed

SK-PULL-SA / SK-PULL-DA Technical Specifications

PHYSICAL

Dimensions: 5.5" H x 4" W x 1.45" D (14 x 10.2 x 3.7cm)

Housing Material: LEXAN polycarbonate resin

Bi-Colored LED:

Blinking Green: Normal

Steady Red: Alarm

Switch: Single pole, single throw (SPST) normally open (N/O) switch which closes upon activation of the pull station

ELECTRICAL

Operating Voltage: 15 – 32VDC

SLC Standby and Alarm Current: 350 μ A

Wire Gauge: Up to 12AWG (3.1 mm²)

ENVIRONMENTAL

Operating Temperature: 32°F – 120°F (0°C – 49°C)

Humidity: 10% – 93% non-condensing

ORDERING INFORMATION

SK-Pull-SA: Single Action Pull Station

SK-Pull-DA: Dual Action Pull Station

ACCESSORIES

BG-TR: Optional trim ring.

SB-I/O: Surface backbox, indoor/outdoor.

* Unless otherwise noted, specifications apply to SK-Pull-SA and SK-Pull-DA

COMPATIBILITY

The SK-PULL-SA AND SK-PULL-DA are compatible with the following Honeywell Silent Knight fire alarm control panels:

6820: Addressable fire alarm control panel

6820EVS: Addressable fire alarm control panel with an emergency voice system.

6808: Addressable fire alarm control panel

6700: Addressable fire alarm control panel

5700: Addressable fire alarm control panel

5808: Addressable fire alarm control panel

5820XL: Addressable fire alarm control panel

5820XL-EVS: Addressable fire alarm control panel with an emergency voice system

For a complete listing of all compliance approvals and certifications, please visit www.silentknight.com.

Microsoft, Windows, and the Windows Logo are registered trademarks or trademarks of Microsoft Corporation.

Silent Knight®, System Sensor® and Honeywell® are registered trademarks of Honeywell International, Inc.

This document is not intended to be used for installation purposes. We try to keep our product information up-to date and accurate. We cannot cover all specific applications or anticipate all requirements. All specifications are subject to change without notice.

For Technical Support, call 800-446-6444.

For more information

Learn more about Honeywell Silent Knight and other products by visiting www.silentknight.com

Honeywell Silent Knight

12 Clintonville Road
Northford, CT 06472
800-328-0103

Honeywell



SK-MONITOR-2

Addressable Dual Monitor Module

The SK-MONITOR-2 module is capable of monitoring two separate Class B circuits simultaneously, making it ideal for waterflow tamper switch and flow switch monitoring.

The SK-MONITOR-2 is an addressable monitor module with two initiating circuits for use with Honeywell Silent Knight series fire alarm control panels (FACPs). The SK-MONITOR-2 acts as an interface to contact devices, such as waterflow switches and pull stations.

The SK-MONITOR-2 supports Class B supervised wiring to the load device. Conventional 4-wire smoke detectors can be monitored for alarm and trouble conditions..

INSTALLATION

SK-MONITOR-2 mounts directly into a 4" square electrical box. The box must have a minimum depth of 2-1/8". A surface mount electrical box (System Sensor® part number SMB500) is available from Silent Knight.



SK-MONITOR-2

FEATURES & BENEFITS

- Monitor two circuits, with unique addresses, simultaneously
- Support for Class B wiring
- Fully supervised
- Panel controlled status LED that flashes green in normal state and is solid red in alarm
- Attractive ivory cover plate
- Rotary address switches for fast installation
- SEMS screws for easy wiring

SK-MONITOR-2 Technical Specifications

For a complete listing of all compliance approvals and certifications, please visit www.silentknight.com.

Microsoft, Windows, and the Windows Logo are registered trademarks or trademarks of Microsoft Corporation.

Silent Knight®, System Sensor® and Honeywell® are registered trademarks of Honeywell International, Inc.

This document is not intended to be used for installation purposes. We try to keep our product information up-to date and accurate. We cannot cover all specific applications or anticipate all requirements. All specifications are subject to change without notice.

For Technical Support, call 800-446-6444.

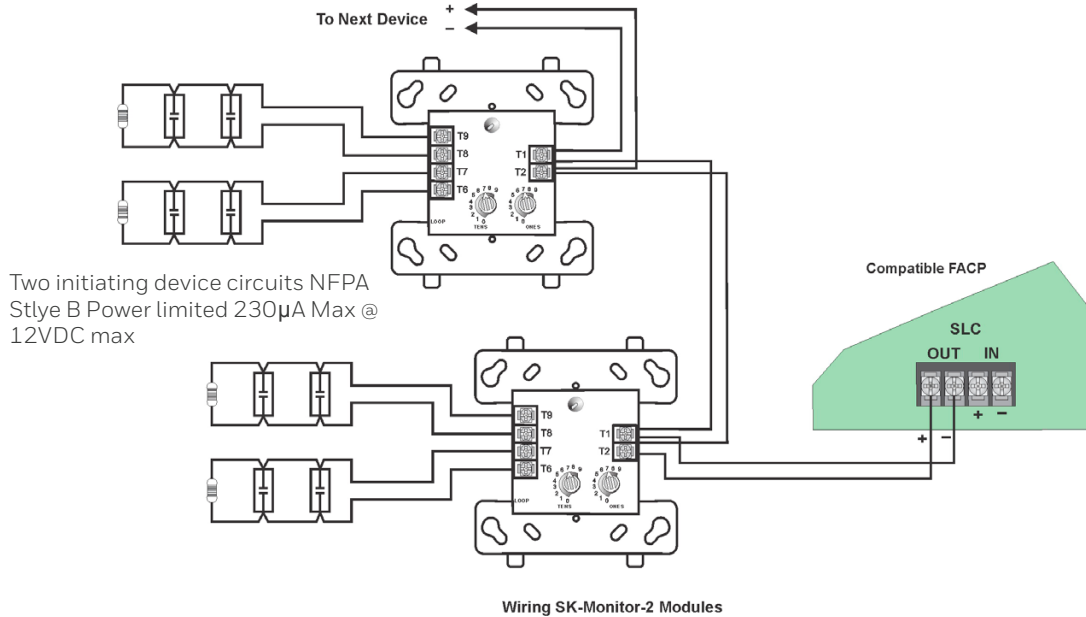

PHYSICAL

Height: 4.5" H x 4" W x 1.25" D
Shipping Weight: 6.3 oz (196 g)

ELECTRICAL

Operating Voltage: 15 – 32 VDC
Standby and Alarm Current: 750µA max @ 24VDC (one communication every 5 sec with 47K EOL)
End-of-Line Resistance: 47KΩ

ENVIRONMENTAL

Operating Temperature: 32°F – 120°F (0°C – 49°C)
Humidity: 10% – 93% non-condensing

ORDERING INFORMATION

SK-Monitor-2: Dual Monitoring Module

ACCESSORIES

SMB500: 4" Square Surface Mount Electrical Box

AGENCY LISTINGS AND APPROVALS

UL Listed
CSFM Approved
City of New York Approved

COMPATIBILITY

The SK-MONITOR-2 is compatible with the following Honeywell Silent Knight fire alarm control panels:

- 6820: Addressable fire alarm control panel
- 6820EVS: Addressable fire alarm control panel with an emergency mass notification system.
- 6808: Addressable fire alarm control panel
- 6700: Addressable fire alarm control panel
- 5700: Addressable fire alarm control panel
- 5808: Addressable fire alarm control panel
- 5820XL: Addressable fire alarm control panel
- 5820XL-EVS: Addressable fire alarm control panel with an emergency mass notification system.

For more information

Learn more about Honeywell Silent Knight and other products by visiting www.silentknight.com

Honeywell Silent Knight

12 Clintonville Road
Northford, CT 06472
800-328-0103

Honeywell



SK-CONTROL

Intelligent Notification Module

The SK-CONTROL is an addressable notification module for use with Honeywell Silent Knight series fire alarm control panels (FACPs). The SK-CONTROL provides supervised monitoring of wiring to load devices that require an external power supply to operate, such as bells, horns, and strobes. It is capable of Class B (Styles Y) and Class A (Style Z) supervision.

Upon command from the FACP, the SK-CONTROL will disconnect the supervision and connect the external power supply across the load device. The disconnection of the supervision provides a positive indication to the panel that the control relay actually turned on. The external power supply is always relay isolated from the SLC loop, so that a trouble condition on the power supply will never interfere with the rest of the system.

INSTALLATION

The SK-CONTROL mounts directly into a 4" square electrical box. The box must have a minimum depth of 2-1/8". A surface mount electrical box (System Sensor® PN SMB500) is available from Silent Knight.

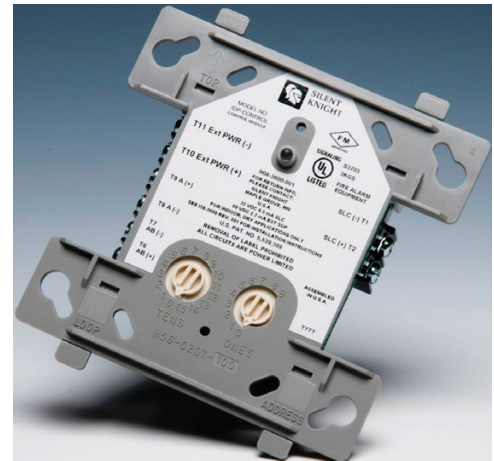

SK-CONTROL

FEATURES & BENEFITS

- Flexible solution for adding notification circuits where needed
- Support for Class B (style Y) or Class A (style Z) wiring
- Panel controlled status LED that flashes green in normal state and is solid red in alarm
- Polling LED visible through the cover plate
- Attractive ivory cover plate
- Rotary address switches for fast installation
- SEMS screws for easy wiring
- UL Listed

SK-CONTROL Technical Specifications

PHYSICAL

Dimensions: 4.5" H x 4" W x 1.3" D (11.4 cm x 10.2 cm x 3.2 cm)

ELECTRICAL

Operating Voltage: 15 – 32 VDC

External Power Supply

Alarm Current: 7mA per module; Standby Current: 1.7mA

End-of-Line Resistance: 47K Ω

SLC Standby & Alarm Current: .375mA max. @ 24 VDC (one communication every 5 sec with 47K EOL)

SLC Loop Resistance: 40 Ω max.

ENVIRONMENTAL

Operating Temperature: 32°F – 120°F (0°C – 49°C)

Humidity: 10% – 93% non-condensing

ORDERING INFORMATION

SK-Control: Notification Module

ACCESSORIES

SMB500: 4" Square Surface Mount Electrical Box

CB500: Module Barrier

COMPATIBILITY

The SK-CONTROL is compatible with the following Honeywell Silent Knight fire alarm control panels:

6820: Addressable fire alarm control panel

6820EVS: Addressable fire alarm control panel with an emergency mass notification system.

6808: Addressable fire alarm control panel

6700: Addressable fire alarm control panel

5700: Addressable fire alarm control panel

5808: Addressable fire alarm control panel

5820XL: Addressable fire alarm control panel

5820XL-EVS: Addressable fire alarm control panel with an emergency voice system.

For a complete listing of all compliance approvals and certifications, please visit www.silentknight.com.

Microsoft, Windows, and the Windows Logo are registered trademarks or trademarks of Microsoft Corporation.

Silent Knight®, System Sensor® and Honeywell® are registered trademarks of Honeywell International, Inc.

This document is not intended to be used for installation purposes. We try to keep our product information up-to date and accurate. We cannot cover all specific applications or anticipate all requirements. All specifications are subject to change without notice.

For Technical Support, call 800-446-6444.

For more information

Learn more about Honeywell Silent Knight and other products by visiting www.silentknight.com

Honeywell Silent Knight

12 Clintonville Road
Northford, CT 06472
800-328-0103

Doc 350125 | Rev E | 11/17
© 2017 Honeywell International Inc.



Honeywell



SK-ISO

Intelligent Fault Isolator Module

The SK-ISO is an addressable line isolator module for use with the Honeywell Silent Knight Series fire alarm control panels (FACPs).

The SK-ISO acts as an automatic switch that opens when the line voltage on the signaling line circuit (SLC) loop drops below four volts. Isolator modules should be spaced between groups of sensors or modules in a loop to protect the rest of the loop. If a short occurs between any two isolators, then both isolators immediately switch to an open circuit state and isolate the devices between them. The remaining units on the SLC loop continue to fully operate. No more than 25 devices are recommended for each group.

INSTALLATION

The SK-ISO mounts directly into a 4" square electrical box. The box must have a minimum depth of 2-1/8". A surface mount electrical box (System Sensor® PN SMB500) is available from Silent Knight.



SK-ISO

FEATURES & BENEFITS

- Panel controlled status LED that flashes green in normal state and is solid red in alarm
- Isolates short circuits on an SLC loop
- Protects the modules on the SLC loop so other devices continue to operate
- Standard 4 inch electrical box mounting
- SEMS screws for easy wiring
- UL Listed
- CSFM Listed
- FM Approved

SK-ISO Technical Specifications

PHYSICAL

Dimensions: 4.5" H x 4" W x 0.25" D (11.4 x 10.2 x .6cm)

Shipping Weight: 6.3 oz (196 g)

ELECTRICAL

Operating Voltage: 15 – 32 VDC

Standby Current: 450 μ A max (not isolating; relay closed)

Isolation Current: 5mA max

Fault Detection Delay: 250ms min.

Fault Detection Threshold: 4V

Line Restoration Threshold: 7V

ENVIRONMENTAL

Operating Temperature: 32°F – 120°F (0°C – 49°C)

Humidity: 10% – 93% non-condensing

ORDERING INFORMATION

SK-ISO: Line isolation module

ACCESSORIES

SMB500: 4" Square Surface Mount Electrical Box

COMPATIBILITY

The SK-ISO is compatible with the following Honeywell Silent Knight fire alarm control panels:

6820: Addressable fire alarm control panel

6820EVS: Addressable fire alarm control panel with an emergency voice system.

6808: Addressable fire alarm control panel

6700: Addressable fire alarm control panel

5700: Addressable fire alarm control panel

5808: Addressable fire alarm control panel

5820XL: Addressable fire alarm control panel

5820XL-EVS: Addressable fire alarm control panel with an emergency voice system

For a complete listing of all compliance approvals and certifications, please visit www.silentknight.com.

Microsoft, Windows, and the Windows Logo are registered trademarks or trademarks of Microsoft Corporation.

Silent Knight®, System Sensor® and Honeywell® are registered trademarks of Honeywell International, Inc.

This document is not intended to be used for installation purposes. We try to keep our product information up-to date and accurate. We cannot cover all specific applications or anticipate all requirements. All specifications are subject to change without notice.

For Technical Support, call 800-446-6444.

For more information

Learn more about Honeywell Silent Knight and other products by visiting www.silentknight.com

Honeywell Silent Knight

12 Clintonville Road
Northford, CT 06472
800-328-0103



SS-Series Intelligent Detectors

The System Sensor SS-Series intelligent photoelectric and thermal detectors with integral communication provide point location for alarm communication and selective maintenance.



Features

- UL 268 7th Edition, UL 521, and/or UL 268A certified
- New modern profile
- Analog communications
- Low standby current
- Rotary address switches
- Dual LEDs for 360° visibility
- Expanded color options

SS-Series smoke detectors are intelligent (addressable) detectors with point ID capability that enable each detector address to be set with rotary address switches providing exact device locations. SS-Series detectors support current SK, LiteSpeed™ and SS Protocol systems. Refer to the Addressable Detector and Sounder Base Compatibility Chart or the Intelligent Control Panel SLC Wiring Manual for specific panel compatibility. Detector sensitivity is continually monitored and reported to the fire alarm control panel. The modern design and expanded color options support contemporary aesthetic demands. In addition, each detector is constructed for exceptional installation and maintenance efficiency.

The System Sensor **SS-PHOTO** photoelectric detector's re-designed optical sensing chamber is engineered to sense smoke produced by a wide range of combustion sources in accordance with more stringent code standards. The sensitivity of SS-Series detectors can be programmed using the control panel software to suit the environment. The **SS-PHOTO-R** photoelectric detector is also remote test capable for use with a DNR (DNRW) duct smoke detector. The **SS-PHOTO-T** multi-sensor detector offers either photoelectric detection or thermal detection through dual electronic thermistors at 135°F (57°C) fixed temperature thermal sensing.

SS-Series thermal detectors provide cost-effective, intelligent property protection with a UL 521 listing: the **SS-HEAT** offers 135°F (57°C) fixed thermal detection; the **SS-HEAT-ROR** offers 135°F (57°C) fixed and rate-of-rise thermal detection; the **SS-HEAT-HT** provides fixed high-temperature detection at 190°F.

Agency Listings



SS-PHOTO Series: S911
SS-HEAT Series: S2101



SS-PHOTO Series:
7272-1653:0529
SS-HEAT Series:
7270-1653:0528

SS-Series Intelligent Detector Specifications

Physical/Operating Specifications	
Height	2.0 inches (51 mm)
Diameter	6.2 inches (156 mm) installed in B300-6 base; 4.1 inches (104 mm) installed in B501-WHITE/-IV/-BL base
Shipping Weight	3.4 oz (95 g)
Operating Temperature Range	Photo: 32°F to 122°F (0°C to 50°C) Photo with Remote Test: 32°F to 122°F (0°C to 50°C); -4°F to 158°F (-20°C to 70°C) in duct applications Photo with Thermal: 32°F to 115°F (0°C to 47°C) Heat - Fixed-temperature: -4°F to 115°F (-20°C to 47°C) Heat - Rate of Rise (ROR): -4°F to 115°F (-20°C to 47°C) Heat - High Temperature: -4°F to 150°F (-20°C to 66°C)
UL-Listed Velocity Range	Photo, Photo with Thermal, Photo with Remote Test: 0 to 4,000 fpm (0 to 1,219 m/minute) (suitable for installation in ducts)
Operating Humidity Range	10% to 93% non-condensing
Thermal Ratings	Fixed Temperature Setpoint: 135°F (57°C) Rate-of-Rise Detection: 15°F/min. (8.3°C/min.) High Temperature Heat: 190°F (88°C)
Sensitivity Range	SS-PHOTO, SS-PHOTO-R, SS-PHOTO-T: Open area 2.86–5.0%/FT. Special Application 0.5–2.86%/FT.
Electrical Specifications	
Voltage Range	15 to 32 VDC peak
Operating Current @ 24 VDC	200 uA (one communication every 5 seconds with green LED blink on communication)
Maximum Current	4.5 mA @ 24 VDC (one communication every 5 seconds with amber LED solid on)
Maximum Alarm Current	2 mA @ 24 VDC (one communication every 5 seconds with red LED solid on)

Ordering Information

Part No.			Description
White	Ivory	Black	
SS-PHOTO	—	—	Photoelectric smoke detector
SS-PHOTO-R	—	—	Photoelectric smoke detector, remote test capable, for use with DNR(W) duct smoke detectors
SS-PHOTO-T	—	—	Photoelectric smoke detector with thermal
SS-HEAT	—	—	Fixed temperature thermal detector
SS-HEAT-ROR	—	—	Fixed temperature and Rate-of-rise thermal detector
SS-HEAT-HT	—	—	High temperature thermal detector
Bases			
B501-WHITE	B501-IV	B501-BL	4" Mounting base
B501-WHITE-BP	—	—	4" Mounting base, bulk pack (10)
B300-6	B300-6-IV	—	6" Flanged mounting base
B300-6-BP	—	—	6" Flanged mounting base, bulk pack (10)
B200S-WH	B200S-IV	—	Intelligent addressable sounder base
B200S-LF-WH	B200S-LF-IV	—	Intelligent addressable sounder base, low-frequency
B200SR	B200SR-IV	—	Intelligent sounder base
B200SR-LF	B200SR-LF-IV	—	Intelligent sounder base, low frequency
B224RB	B224RB-IV	—	Relay base
B224BI	B224BI-IV	—	Isolator base
Accessories			
—	SMB600	—	Surface Mounting Kit (flanged)
TR300	TR300-IV	—	Trim ring
CK300	CK300-IV	CK300-BL	Color Kit (includes cover and trim ring)
—	RA100Z	—	RA100Z Remote LED annunciator
M02-04-00	—	—	Detector test magnet
M02-09-00	—	—	Telescoping test magnet

Accessories

RA100Z
Remote LED
Annunciator



CK300-BL
Color Kit



TR300
Trim Ring

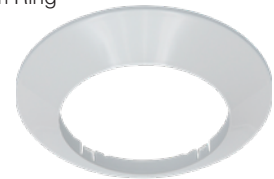

System Sensor® is a registered trademark of
and LiteSpeed™ is a trademark of
Honeywell International, Inc.



3825 Ohio Avenue • St. Charles, IL 60174
Phone: 800-SENSOR2 • Fax: 630-377-6495

©2024 System Sensor.
Product specifications subject to change without notice. Visit systemsensor.com
for current product information, including the latest version of this data sheet.
SPDS-62165 Rev. B • 5/8/2024



L-Series and L-Series with LED Indoor Selectable Horns, Strobes and Horn Strobes

System Sensor L-Series and L-Series with LED audible visible notification products are rich with features guaranteed to cut installation times and maximize profits with lower current draw and modern aesthetics.



Features

- LED technology provides lower current draw
- Digital Voltage Meter (DVM) diagnostic test points for Horn Strobes and Strobes
- Common aesthetics across the L-Series platform
- Standard and compact sizes
- Tamper-resistant construction
- Field-selectable candela settings on wall units: 15, 30, 75, 95, 110, 135, and 185
- Field-selectable candela settings on ceiling units: 15, 30, 75, 95, 115, 150, and 177
- Rotary switches for candela, tone and volume selections
- Mounting plate provides plug-in design for easier installation and shorting springs to check wiring continuity
- Electrically compatible with legacy SpectrAlert, SpectrAlert Advance and L-series devices
- Synchronization through use of UL approved power supplies that support System Sensor Sync protocol or System Sensor MDL3 Sync Module
- Horns, Strobes and Horn Strobes listed for wall or ceiling use

Agency Listings

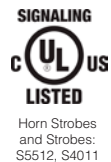

The System Sensor L-Series and L-Series with LED platform

offers the most versatile and easy-to-use line of horns, strobes, and horn strobes in the industry with lower current draw and modern aesthetics. LED lighting technology offers significantly lower current draw compared to older Xenon bulbs across a full candela range. This improves design flexibility for notification appliance circuits (NACs) while also reducing power supply requirements allowing for simpler and lower cost installations.

Flexible design options meet virtually any application requirement: wall or ceiling mount, standard or compact sizes, red or white color choices, bezel kits for alternate markings and languages, and LED color lenses for distinctive visual signaling. In addition, installers can easily adapt devices using field selectable candela, tone and volume settings using rotary switches.

The L-Series and L-Series with LED line is developed to simplify installation. All devices feature plug-in designs with minimal intrusion into the back box, making installations fast and foolproof while virtually eliminating costly and time-consuming ground faults. The universal mounting plate includes an onboard shorting spring, so installers can test wiring continuity before the device is installed.

In addition, the System Sensor L-Series with LED notification appliances offer a new diagnostic test point feature that allows you to measure device voltage with a digital voltage meter (DVM) without removing the appliance from the wall or ceiling. The DVM test points are discreetly located on the face of the notification appliance which enable faster troubleshooting and end of line (EOL) voltage checks while greatly reducing the risk of misplacing or damaging appliances during troubleshooting.

L-Series and L-Series with LED Specifications

Physical/Electrical Specifications	
Standard Operating Temperature	32°F to 120°F (0°C to 49°C)
Humidity Range	10 to 93% non-condensing
Strobe Flash Rate	1 flash per second
Nominal Voltage, LED Strobes and Horn Strobes	Regulated 24 VDC
Nominal Voltage, Horns	Regulated 12 VDC or regulated 24 DC/FWR
Operating Voltage Range, LED Strobes and Horn Strobes	16 to 33 V (24 V nominal)
Operating Voltage Range, Horns	8 to 17.5 V (12 V nominal) or 16 to 33 V (24 V nominal)
Input Terminal Wire Gauge	12 to 18 AWG

UL/ULC Current Draw Data, Horn Tones, and Sound Output Data

UL/ULC Maximum Strobe Current Draw (mA)			
Candela Range	Candela Rating	16–33 Volts	
		Wall	Ceiling
Candela Range	15	18	18
	30	22	22
	75	70	70
	95	75	75
	110	85	—
	115	—	90
	135	105	—
	150	—	110
	177	—	115
	185	120	—

UL/ULC Maximum Horn Current Draw (mA RMS)				
Sound Pattern	dB	8–17.5 Volts		
		DC	DC	FWR
Temporal	High	39	44	54
Temporal	Low	28	32	54
Non-Temporal	High	43	47	54
Non-Temporal	Low	29	32	54
3.1 KHz Temporal	High	39	41	54
3.1 KHz Temporal	Low	29	32	54
3.1 KHz Non-Temporal	High	42	43	54
3.1 KHz Non-Temporal	Low	28	29	54
Coded	High	43	47	54
3.1 KHz Coded	High	42	43	54

UL/ULC Maximum Horn Strobe Current Draw (mA) and Sound Output (dBA)														
Switch Pos.	Sound Pattern	Volume Setting	Current Draw (mA RMS), Horn Strobe, Candela Range (15-185 cd)										Sound Output (dBA)	
			16-33 Volts											16-33V DC
			15cd	30cd	75cd	95cd	110cd	115cd	135cd	150cd	177cd	185cd		
			WALL	CEILING	WALL	CEILING	WALL	CEILING	CEILING	WALL				
1	Temporal 3	High	35	38	87	92	94	120	189	189	190	190	87	
2	Temporal 3	Low	35	38	87	92	94	120	135	135	145	145	79	
3	Non-Temporal	High	50	52	87	92	94	120	127	127	135	135	87	
4	Non-Temporal	Low	35	38	87	92	94	120	125	125	130	130	79	
5	3.1KHz Temporal 3	High	35	38	87	89	91	115	155	155	165	165	86	
6	3.1KHz Temporal 3	Low	35	38	87	89	91	115	128	130	135	135	80	
7	3.1KHz Non-Temporal	High	40	42	87	89	91	115	125	125	135	135	86	
8	3.1KHz Non-Temporal	Low	35	38	87	89	91	115	120	120	130	130	80	

L-Series with LED Dimensions: Wall-Mounted Equipment

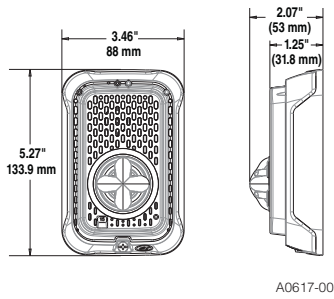

A0617-00

**Compact Strobe, Horn Strobe
for Wall**

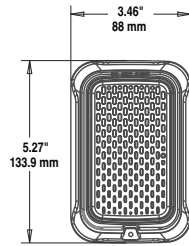

A0547-00

Compact Horn

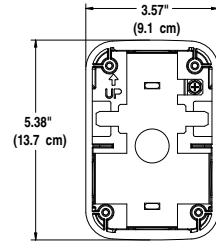
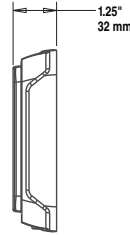

A0557-00

**Compact Surface Mount Back Box
for Walls (SBBGRL, SBBGWL)**

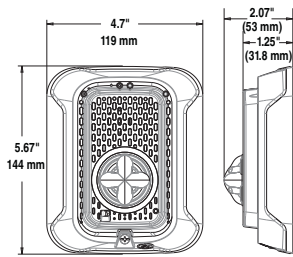

A0613-00

**Strobes, Horn Strobes
for Walls**

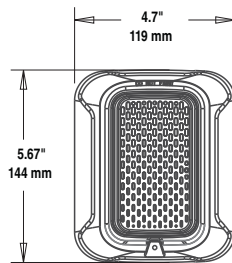

A0549-00

Horn

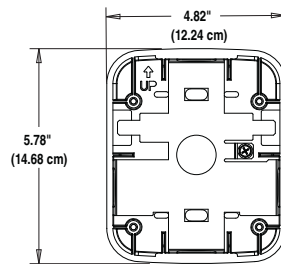
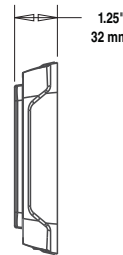

A0554-01

**Surface Mount Back Box
for Walls (SBBRL/SBBWL)**

L-Series with LED Dimensions: Ceiling-Mounted Equipment

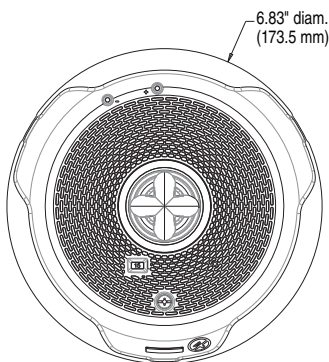

A0608-00

**Strobes and Horn Strobes
for Ceilings**

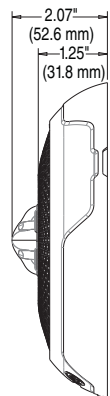

6.92" diam.
(175.77 mm)

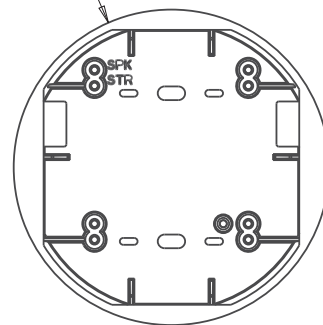

A0546-00

**Surface Mount Back Box
for Ceilings (SBBCL, SBCWL)**

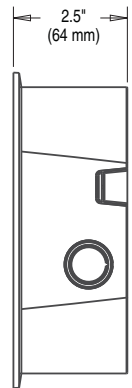

L-Series with LED: Ordering Information

Model	Description
L-Series with LED Horn Strobes	
P2RLED	2-Wire, Horn Strobe, Wall, Red
P2RLED-B	2-Wire, Horn Strobe, Wall, Red, Bilingual
P2WLED	2-Wire, Horn Strobe, Wall, White
P2WLED-B	2-Wire, Horn Strobe, Wall, White, Bilingual
P2GRLED	2-Wire, Compact Horn Strobe, Wall, Red
P2GRLED-B	2-Wire, Compact Horn Strobe, Wall, Red, Bilingual
P2GWLED	2-Wire, Compact Horn Strobe, Wall, White
P2GWLED-B	2-Wire, Compact Horn Strobe, Wall, White, Bilingual
P2RLED-P	2-Wire, Horn Strobe, Wall, Red, Plain
P2WLED-P	2-Wire, Horn Strobe, Wall, White, Plain
P2RLED-SP	2-Wire, Horn Strobe, Wall, Red, FUEGO
P2WLED-SP	2-Wire, Horn Strobe, Wall, White, FUEGO
PC2RLED	2-Wire, Horn Strobe, Ceiling, Red
PC2RLED-B	2-Wire, Horn Strobe, Ceiling, Red, Bilingual
PC2WLED	2-Wire, Horn Strobe, Ceiling, White
PC2WLED-B	2-Wire, Horn Strobe, Ceiling, White, Bilingual
L-Series with LED Strobes	
SRLED	Strobe, Wall, Red
SRLED-B	Strobe, Wall, Red, Bilingual
SWLED	Strobe, Wall, White
SWLED-B	Strobe, Wall, White, Bilingual
SGRLED	Strobe, Compact, Wall, Red
SGRLED-B	Strobe, Compact, Wall, Red, Bilingual
SGWLED	Strobe, Compact, Wall, White
SGWLED-B	Strobe, Compact, Wall, White, Bilingual
SRLED-P	Strobe, Wall, Red, Plain
SWLED-P	Strobe, Wall, White, Plain
SRLED-SP	Strobe, Wall, Red, FUEGO
SWLED-CLR-ALERT	Strobe, Wall, White, ALERT
SWLED-ALERT	Strobe, Wall, White, ALERT, Amber Lens
SCRLED	Strobe, Ceiling, Red
SCRLED-B	Strobe, Ceiling, Red, Bilingual
SCRLED-P	Strobe, Ceiling, White, Plain
SCWLED	Strobe, Ceiling, White
SCWLED-B	Strobe, Ceiling, White, Bilingual
SCWLED-P	Strobe, Ceiling, White, Plain
SCWLED-CLR-ALERT	Strobe, Ceiling, White, ALERT
L-Series Horns	
HRL*	Horn, Red
HRLA*	Horn, Red, Plain, ULC
HWL*	Horn, White
HWLA*	Horn, White, Plain, ULC
HGRL*	Compact Horn, Red
HGRLA*	Compact Horn, Red, Plain, ULC
HGWL*	Compact Horn, White
HGWLA*	Compact Horn, White, Plain, ULC

Model	Description
LED Lenses	
LENS-A3	Lens LED Amber Wall/Ceiling
LENS-B3	Lens LED Blue Wall/Ceiling
LENS-G3	Lens LED Green Wall/Ceiling
LENS-R3	Lens LED Red Wall/Ceiling
Accessories	
TR-2	Universal Wall Trim Ring Red
TR-2W	Universal Wall Trim Ring White
SBBRL	Wall Surface Mount Back Box, Red
SBBWL	Wall Surface Mount Back Box, White
SBBGRL	Compact Wall Surface Mount Back Box, Red
SBBGWL	Compact Wall Surface Mount Back Box, White
TRC-2	Universal Ceiling Trim Ring, Red
TRC-2W	Universal Ceiling Trim Ring, White
SBBCRL	Ceiling Surface Mount Back Box, Red
SBBCWL	Ceiling Surface Mount Back Box, White
Bezels†	
BZR	Wall Red Bezel Kit
BZW	Wall White Bezel Kit
BZGR	Compact Wall Red Bezel Kit
BZGW	Compact Wall White Bezel Kit
BZRC	Horn Strobe Ceiling Red Bezel Kit
BZWC	Horn Strobe Ceiling White Bezel Kit

Notes for L-Series With LED Horn Strobes and Strobes:

All -P models have a plain housing (no "FIRE" marking on cover).
 All -SP models have "FUEGO" marking on cover.
 All -ALERT models have "ALERT" marking on cover.
 All -B models have "FIRE/FEU" marking on cover for use in Canadian applications.
 Amber lenses are not for use in Canadian applications

Notes for L-Series Horns:

*Horn-only models are listed for wall or ceiling use.

Notes for Bezels:

†Each bezel pack ships in a package of 5.
 Add one of the following extensions for print/language options: -F (FIRE), -AL (ALERT), -EV (EVAC), -AG (AGENT), -P (Plain), -FR (FEU), -PG (FOGO), -SP (FUEGO), -SPE (FUEGO/FIRE).

3825 Ohio Avenue • St. Charles, IL 60174 USA
 Phone: 800-SENSOR2 • Fax: 630-377-6495
www.systemsensor.com

3333 Unity Drive, Mississauga, ON L5L 3S6 Canada
 Phone: 800-SENSOR2 • Fax: 905-812-0771
www.systemsensor.ca

System Sensor® is a registered trademark
 of Honeywell International, Inc.



©2023 System Sensor.
 Product specifications subject to change without notice. Visit www.systemsensor.com
 for current product information, including the latest version of this data sheet.
 AVDS916-01 • 10/03/2023



Indoor Selectable-Output Low Frequency Sounders and Low Frequency Sounder Strobes

System Sensor L-Series audible visible notification products are rich with features guaranteed to maximize profits with lower current draw and modern aesthetics.



Features

- 520 Hz \pm 10% square wave tone, NFPA compliance
- Full candela range plus High/Low tone options to optimize current draw for a wide variety of applications
- Compact, standard, and round ceiling options
- Field-selectable candela settings. Wall units: 15, 30, 75, 95, 110, 135, and 185. Ceiling units: 15, 30, 75, 95, 115, 150, and 177
- Rotary switch for High/Low, Temp3, Temp4, and Continuous settings. Sounder-only models also offer a Coded setting.
- Plug-in design with minimal intrusion into the back box
- Mounting plate shorting spring checks wiring continuity before device installation
- Electrically compatible with legacy SpectrAlert and SpectrAlert Advance devices (Direct replacement for HW/R-LF and P2R/WH-LF)
- Compatible with MDL3 sync module
- Sounders listed for ceiling and wall
- Round Sounder Strobes listed for ceiling and wall
- Updated modern aesthetics

Agency Listings



The L-Series offers the most versatile and easy-to-use line of low frequency sounder and low frequency sounder strobes in the industry. With white and red plastic housings, listed for wall and ceiling mounting, L-Series Low Frequency can meet virtually any application requirement.

The low frequency sounder and low frequency sounder strobes were designed to address the NFPA 72 sleeping space requirements that require a low frequency notification appliance that operates within frequency range of 520 Hz \pm 10% and is of a square wave tone. Like the entire L-Series product line they include a variety of features that increase their application versatility while simplifying installation. All devices feature plug-in designs with minimal intrusion into the back box, making installations fast and foolproof while virtually eliminating costly and time-consuming ground faults.

To further simplify installation and protect devices from construction damage, L-Series uses a universal mounting plate with an onboard shorting spring, so installers can test wiring continuity before the device is installed.

Installers can also easily adapt devices to suit a wide range of application requirements using field-selectable candela settings, 24-volt operation, and a rotary switch for 520 Hz low frequency sounder tones.

L-Series Specifications

Architect/Engineer Specifications

General

L-Series low frequency sounder and low frequency sounder strobes shall mount to a standard 4 x 4 x 1½-inch back box, 4-inch octagon back box, or double-gang back box. Two-wire products shall also mount to a single-gang 2 x 4 x 1⅞-inch back box. A universal mounting plate shall be used for mounting products. The notification appliance circuit wiring shall terminate at the universal mounting plate. Also, L-Series products, when used with the Sync•Circuit™ Module accessory, shall be powered from a non-coded notification appliance circuit output and shall operate on a nominal 12 or 24 volts. When used with the Sync•Circuit Module, 24-volt-rated notification appliance circuit outputs shall operate between 16.5 and 33 volts. Indoor L-Series products shall operate between 32 and 120 degrees Fahrenheit (0°C to 49°C) from a regulated DC or full-wave rectified unfiltered power supply. Low Frequency Sounder strobes shall have field-selectable candela settings. Wall units: 15, 30, 75, 95, 110, 135, and 185. Ceiling units: 15, 30, 75, 95, 115, 150, and 177. The field selectable tones will sound within the frequency range of 520 Hz ±10% square wave tone and have a permanent marking on the housing that reads "520 Hz".

Low Frequency Sounder

The low frequency sounder shall be a System Sensor L-Series Model _____ listed to UL 464 and shall be approved for fire protective service. The low frequency sounder and the Sync•Circuit™ MDL3 Module accessory, if used, shall be powered from a notification appliance circuit output and shall operate on a nominal 24 volts (includes fire alarm panels with built-in sync). When used with the Sync•Circuit Module MDL3, 24-volt rated notification appliance circuit outputs shall operate between 16.5 to 33 volts. If the notification appliances are not UL 9th edition listed with the corresponding panel or power supply being used, then refer to the compatibility listing of the panel to determine maximum devices on a circuit. The low frequency sounder has an option to switch between temporal three or temporal four pattern, non-temporal (continuous) pattern and coded supply within the frequency range of 520 Hz ± 10% square wave tone. The low frequency sounder shall operate on a coded or non-coded power supply with high and low volume settings.

Low Frequency Sounder Strobe Combination

The low frequency sounder strobe shall be a System Sensor L-Series Model _____ listed to UL 1971 and UL 464 and shall be approved for fire protective service. The low frequency sounder strobe shall be wired as a primary-signaling notification appliance and comply with the Americans with Disabilities Act requirements for visible signaling appliances, flashing at 1 Hz over the strobe's entire operating voltage range. The strobe light shall consist of a xenon flash tube and associated lens/reflector system. The sounder shall have an option to switch between a temporal three or temporal four pattern and a non-temporal (continuous) pattern. These options are set by a multiple position switch. The low frequency sounder on low frequency sounder strobe models shall operate on a non-coded power supply with high and low volume settings. The field selectable tones will sound within the frequency range of 520 Hz ±10% square wave tone.

Synchronization Module

The module shall be a System Sensor Sync•Circuit model MDL3 listed to UL 464 and shall be approved for fire protective service. The module shall synchronize SpectrAlert strobes at 1 Hz and low frequency sounder at temporal three. Also, while operating the strobes, the module shall silence the low frequency sounder on low frequency sounder strobe models over a single pair of wires. The module shall mount to a 4^{11/16} x 4^{11/16} x 2⅞-inch back box. The module shall also control two Class B circuits or one Class A circuit. The module shall synchronize multiple zones. Daisy chaining two or more synchronization modules together will synchronize all the zones they control. The module shall not operate on a coded power supply.

Physical/Electrical Specifications

Standard Operating Temperature	32°F to 120°F (0°C to 49°C)
Humidity Range	10 to 93% non-condensing
Frequency Range	520 Hz ± 10%
Strobe Flash Rate	1 flash per second
Nominal Voltage Low Frequency Sounder	Regulated 24 DC/FWR ¹
Nominal Voltage Range Low Frequency Sounder Strobe	Regulated 24 VDC/FWR ¹
Operating Voltage Range	16 to 33 V (24 V nominal)
Operating Voltage Range MDL3 Sync Module	16.5 to 33 V (24 V nominal)
Input Terminal Wire Gauge	12 to 18 AWG

Dimensions

Wall Sounder Strobe (including lens)	5.6" L x 4.7" W x 1.9" D (142 mm L x 119 mm W x 49 mm D)
Ceiling Sounder Strobe (including lens)	6.8" diameter x 2.47" high (173mm diameter x 62.7 mm D)
Standard Wall Sounder	5.6" L x 4.7" W x 1.5" D (142 mm L x 119 mm W x 38 mm D)
Compact Wall Sounder	5.25" L x 3.46" W x 1.5" D (133mm L x 88mm W x 38mm D)
Ceiling Sounder	6.8" diameter x 1.4" high (173mm diameter x 36mm high)
Standard Wall Sounder with SBBRL/SBBWL Surface Mount Back Box	5.70" L x 4.8" W x 3.3" D (145 mm L x 120 mm W x 87 mm D)
Compact Wall Sounder with SBBGRL/SBBGWL Surface Mount Back Box	5.4" L x 3.6" W x 3.0" D (137 mmL x 91mm W x 76 mm D)
Low Frequency Ceiling Sounder with SBBCRL/SBBCWL Surface Mount Back Box	6.9" diameter x 3.9" high (175mm diameter x 99mm high)

Notes:

1. Full Wave Rectified (FWR) voltage is a non-regulated, time-varying power source that is used on some power supply and panel outputs.

UL Current Draw and Sound Output Data

Low Frequency Sounder Strobe Current Draw (mA) and Sound Output (dBA)																		
Wall Sounder Strobe			Current Draw (mA)														Sound Output (dBA)	
Pos	Tone	Volume Setting	16-33 VDC							16-33 FWR							16-33 V	
			15cd	30cd	75cd	95cd	110cd	135cd	185cd	15cd	30cd	75cd	95cd	110cd	135cd	185cd	DC	FWR
1	Temporal 3	High	98	115	158	173	182	212	266	136	153	188	206	228	258	304	80	80
2	Temporal 3	Low	98	102	141	162	173	202	255	150	150	176	194	216	242	280	76	76
3	Temporal 4	High	98	108	137	151	178	202	252	200	198	169	188	212	242	290	80	80
4	Temporal 4	Low	102	104	122	136	163	187	237	176	174	154	173	197	227	275	76	76
5	Continuous	High	141	158	198	216	234	264	305	190	207	249	268	289	321	368	80	80
6	Continuous	Low	120	128	179	196	215	244	285	165	182	226	244	266	297	342	76	76

Ceiling Sounder Strobe																		
Ceiling Sounder Strobe			Current Draw (mA)														Sound Output (dBA)	
Pos	Tone	Volume Setting	16-33 VDC							16-33 FWR							16-33 V	
			15cd	30cd	75cd	95cd	110cd	135cd	185cd	15cd	30cd	75cd	95cd	110cd	135cd	185cd	DC	FWR
1	Temporal 3	High	98	115	158	173	197	236	259	136	153	188	206	238	287	291	80	80
2	Temporal 3	Low	98	102	141	162	181	224	244	150	150	176	194	226	269	269	76	76
3	Temporal 4	High	98	108	145	161	186	224	249	200	198	169	189	222	269	277	80	80
4	Temporal 4	Low	102	104	122	136	170	208	227	176	174	154	173	206	252	263	76	76
5	Continuous	High	141	158	198	216	245	293	295	190	207	249	268	302	357	357	80	80
6	Continuous	Low	120	128	179	196	225	271	273	165	182	226	244	278	330	330	76	76

UL Max. Low Frequency Sounder Current Draw (mA RMS)						
Wall and Ceiling Sounder			Current Draw (mA)		Sound Output (dBA) Reverberant	
Pos	Tone	Volume Setting	16-33 Volts		16-33 Volts	
			DC	FWR	DC	FWR
1	Temporal 3	High	108	150	80	80
2	Temporal 3	Low	78	76	76	76
3	Temporal 4	High	111	151	80	80
4	Temporal 4	Low	80	76	76	76
5	Continuous	High	111	151	80	80
6	Continuous	Low	80	76	76	76
7	Coded	High	111	151	80	80
8	Coded	Low	80	76	76	76

*NOTE: For coded tones, temporal coding must be provided by the NAC. If the NAC voltage is held constant, the sounder output will remain constantly on. Coded ratings provided are for continuous voltage.

L-Series Dimensions

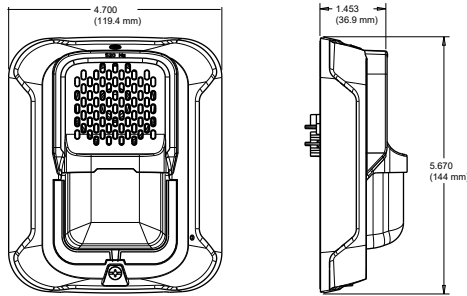

Wall LF Sounder Strobe

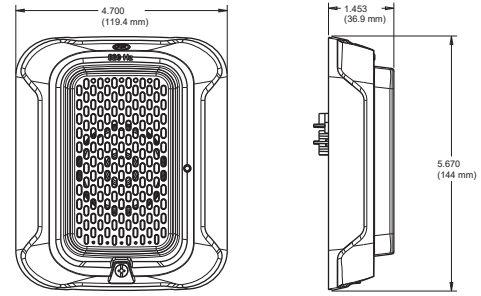

Wall LF Sounder

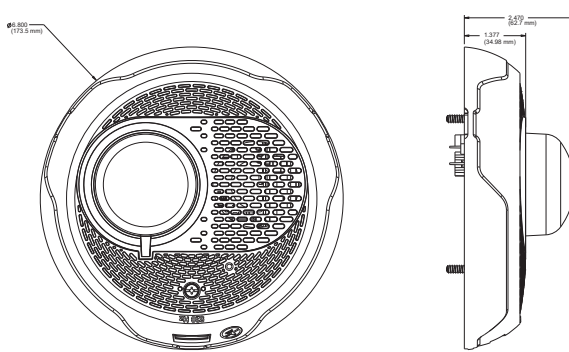

Ceiling LF Sounder Strobe

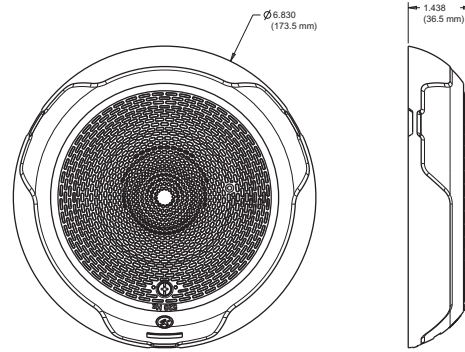

Ceiling LF Sounder

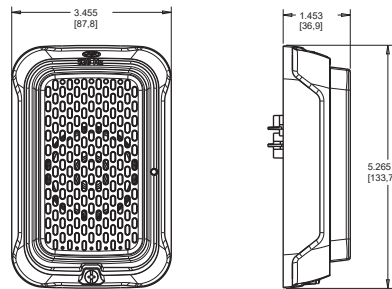

Compact Wall LF Sounder

Part No.		Description
Red	White	
Low Frequency Sounder Strobes		
P2RL-LF	P2WL-LF	LF Sounder Strobe, Wall
PC2RL-LF	PC2WL-LF	LF Sounder Strobe, Ceiling
Low Frequency Sounders		
HRL-LF	HWL-LF	LF Sounder, Wall
HGRL-LF	HGWL-LF	Compact LF Sounder, Wall
HCRL-LF	HCWL-LF	LF Sounder, Ceiling
Accessories		
MDL3R	MDL3W	Sync•Circuit™ Module, UL-listed
SBBRL	SBBWL	Surface Mount Back Box, Wall
SBBCRL	SBBCWL	Surface Mount Back Box, Ceiling
SBBGRL	SBBGWL	Surface Mount Back Box, Wall, Compact

System Sensor® is a registered trademark and Sync•Circuit™ is a trademark of Honeywell International, Inc.



3825 Ohio Avenue • St. Charles, IL 60174
Phone: 800-SENSOR2 • Fax: 630-377-6495

©2020 System Sensor.
Product specifications subject to change without notice. Visit systemsensor.com for current product information, including the latest version of this data sheet.
AVDS910-02 • 11/02/2020



L-Series Outdoor Horns and L-Series with LED Outdoor Strobes and Horn Strobes

System Sensor L-Series and L-Series with LED Outdoor audible visible notification products are rich with features guaranteed to cut installation times and maximize profits with lower current draw and modern aesthetics.

Features

- Weatherproof per NEMA 4X, IP56 as a standalone device
- Rated from -40°F to 151°F
- Electrically compatible with Legacy SpectrAlert Advance and SpectrAlert devices at 16-33 VDC
- Field-selectable candela settings on wall units: 15, 30, 75, 95, 110, 135, and 185
- Field-selectable candela settings on ceiling units: 15, 30, 75, 95, 115, 150, and 177
- Rotary switches for candela, horn, and volume
- Mounting plates with wirenuts are provided to make the connection between the field wiring and the mounting plates
- Synchronization through use of UL approved power supplies that support System Sensor Sync or System Sensor MDL Sync Module
- Tamper-resistant construction
- Listed for ceiling or wall mounting
- Compact size for Wall Mount



The System Sensor L-Series Outdoor and L-Series with LED Outdoor platforms offer the most versatile and easy-to-use line of Weatherproof Horns, Horn Strobes, and Strobes that can meet virtually any application requirement, including indoor, outdoor, wet, dry, and washdown environment applications in temperatures from -40°F to 151°F.

The L-Series Outdoor and L-Series with LED Outdoor appliances are NEMA 4X and IP56 rated without having to seal the backbox. Additional caulk or sealant are not required on the backbox for a faster, cleaner installation. The L-Series platform offers a modern aesthetic across the Indoor and Outdoor platform and design variations across applications: wall or ceiling mount, red or white color choices, LED colored lenses for distinctive visual signaling. In addition, installers can easily adjust appliances through field selectable candela, tone, and volume selections using rotary switches.

LED technology offers significantly lower current draw compared to older Xenon bulbs across a full candela range. This improves design flexibility for notification appliance circuits (NACs) while also reducing power supply requirements allowing for simpler and lower cost installations. UL listed waterproof wirenuts are provided to make the connection between the field wiring and the mounting plates.

Outdoor devices ship with plastic back boxes that accommodate in-and-out wiring for daisy chaining devices. Knock-outs located on the back eliminate the need to drill holes for screw-in mounting. Note: When replacing SpectrAlert Advance products, the backbox should be updated to the L-Series with LED backbox.

Agency Listings



Horns: S4011
Horn Strobes and Strobes:
S4011, S5512



3057072
FM23FPUS0195



7125-1653-0537
7300-1653-0536
7125-1653-0535
7135-1653-0534

Product Specifications

Physical/Electrical Specifications	
Standard Operating Temperature	-40°F to 151°F (-40°C to 66°C)
Humidity Range	0 to 95 ±5%
Strobe Flash Rate	1 flash per second
Nominal Voltage	Regulated 24 VDC
Operating Voltage Range	16 to 33 V (24 V nominal)
Wiring between Fire Alarm Control Panel (FACP) and weatherproof back plate	12 to 18 AWG
Environmental Considerations	Devices meet rating requirements for NEMA 4X, Type 4X, and IP56 as a standalone device

Dimensions	
Wall Strobes and Horn Strobes (including lens)	5.84" L x 3.76" W x 1.56" D (148mm x 95.5mm x 39.6mm)
Wall Strobes and Horn Strobes (including lens) with SBBGRL/WL Surface Mount Back Box	5.84" L x 3.76" W x 3.72" D (148mm x 95.5mm x 94.5mm)
Ceiling Strobes and Horn Strobes (including lens)	6.8" diameter x 2.22" D (173mm x 56.4mm)
Ceiling Strobes and Horn Strobes (including lens) with SBBGRL/WL Surface Mount Back Box	6.98" diameter x 4.72" D (177.3mm x 120mm)
Wall Horns	5.84" L x 3.76" W x 1.56" D (148mm x 95.5mm x 39.6mm)
Wall Horns with SBBGRL/WL Surface Mount Back Box	5.84" L x 3.76" W x 3.11" D (148mm x 95.5mm x 79mm)

NOTE: SBBGRL/WL Surface Mount Back box intended for horns, horn strobes, and strobes.

UL/ULC Maximum Strobe Current Draw (mA)

UL/ULC Maximum Horn Current Draw (mA) and Sound Output (dBA)	
Candela Rating	16 to 33 Volts DC
15	18
30	22
75	70
95	75
110	85
115	90
135	105
150	110
177	115
185	120
FCP*	(future)
*FCP Fire Control Panel, future use	

UL/ULC Maximum Horn Current Draw (mA RMS)

UL/ULC Maximum Horn Current Draw (mA) and Sound Output (dBA)				
Pos	Sound pattern	Volume Setting (dB)	Current Draw (mA RMS), Horn	Sound Output (dBA)
			16-33 Volts DC	16-33 Volts DC
1	Temporal	High	35	85
2	Temporal	Low	35	77
3	Non-Temporal	High	50	85
4	Non-Temporal	Low	35	77
5	3.1KHz Temporal	High	35	82
6	3.1KHz Temporal	Low	35	75
7	3.1KHz Non-Temporal	High	40	82
8	3.1KHz Non-Temporal	Low	35	75

UL/ULC Maximum Horn Strobe Current Draw (mA) and Sound Output (dBA)

Pos	Tone	Volume Setting	Current Draw (mA RMS), Horn Strobe, Candela Range (15-185 cd)										Sound Output (dBA)	
			16-33 Volts											16-33 V DC
			15cd	30cd	75cd	95cd	110cd WALL	115cd CEILING	135cd WALL	150cd CEILING	177cd CEILING	185cd WALL		
1	Temporal	High	35	38	87	92	94	120	189	189	190	190	190	85
2	Temporal	Low	35	38	87	92	94	120	135	135	145	145	145	77
3	Non-Temporal	High	50	52	87	92	94	120	127	127	135	135	135	85
4	Non-Temporal	Low	35	38	87	92	94	120	125	125	130	130	130	77
5	3.1KHz Temporal 3	High	35	38	87	89	91	115	155	155	165	165	165	82
6	3.1KHz Temporal 3	Low	35	38	87	89	91	115	128	130	135	135	135	75
7	3.1KHz Non-Temporal	High	40	42	87	89	91	115	125	125	135	135	135	82
8	3.1KHz Non-Temporal	Low	35	38	87	89	91	115	120	120	130	130	130	75

L-Series with LED Outdoor Dimensions: Wall-Mounted Equipment

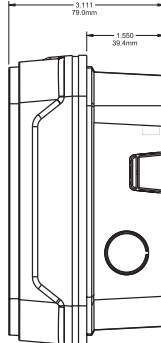
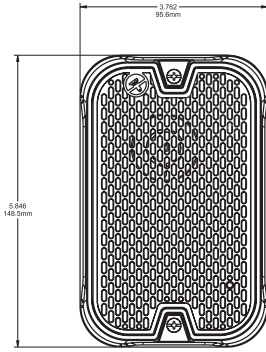

A0547-00

Outdoor Compact Wall Horn with Compact Surface Mount Back Box (SBBGRL/SBBGWL)

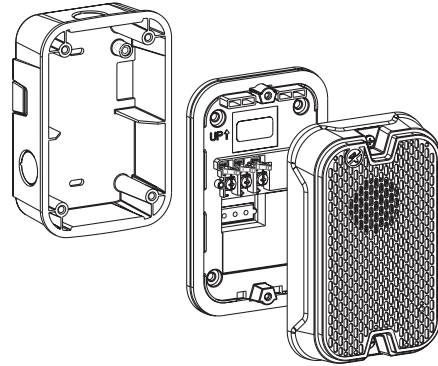

A0557-00

Outdoor Compact Wall Horn with Compact Surface Mount Back Box (SBBGRL/SBBGWL)

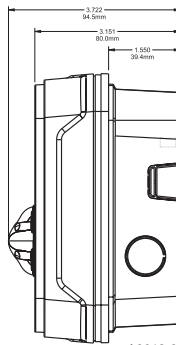
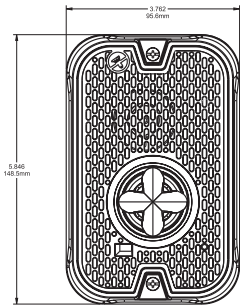

A0613-00

Outdoor Compact Strobes, Horn Strobes for Wall with Compact Surface Mount Back Box (SBBGRL/SBBGWL)

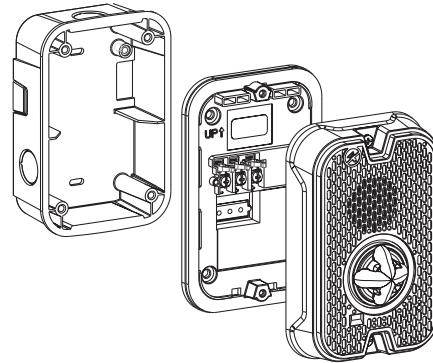

A055v4-01

Outdoor Compact Strobes, Horn Strobes for Wall with Compact Surface Mount Back Box (SBBGRL/SBBGWL)

L-Series with LED Outdoor Dimensions: Ceiling-Mounted Equipment

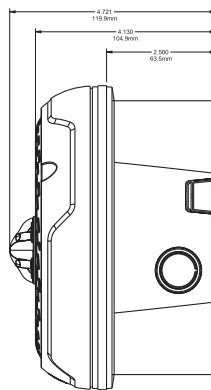
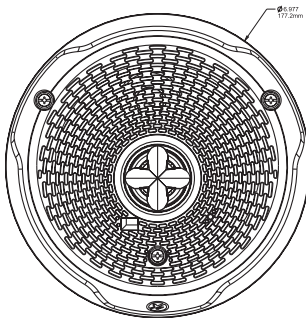

A0608-00

Strobes, Horn Strobes for Ceilings with Surface Mount Back Box (SBBCRL/SBBCWL)

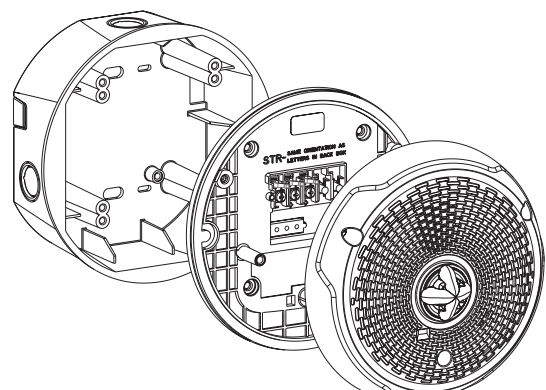

A0546-00

Strobes, Horn Strobes for Ceilings with Surface Mount Back Box (SBBCRL/SBBCWL)

L-Series with LED Outdoor: Ordering Information

Model	Description
L-Series with LED Outdoor Horn Strobes	
P2GRKLED	2-Wire, Compact Horn Strobe, Wall, Red
P2GRKLED-P	2-Wire, Compact Horn Strobe, Wall, Red, Plain
P2GRKLED-B	2-Wire, Compact Horn Strobe, Wall, Red, Bilingual
P2GWKLED	2-Wire, Compact Horn Strobe, Wall, White
P2GWKLED-P	2-Wire, Compact Horn Strobe, Wall, White, Plain
P2GWKLED-B	2-Wire, Compact Horn Strobe, Wall, White, Bilingual
PC2RKLED	2-Wire, Horn Strobe, Ceiling, Red
PC2RKLED-P	2-Wire, Horn Strobe, Ceiling, Red, Plain
PC2RKLED-B	2-Wire, Horn Strobe, Ceiling, Red, Bilingual
PC2WKLED	2-Wire, Horn Strobe, Ceiling, White
PC2WKLED-P	2-Wire, Horn Strobe, Ceiling, White, Plain
PC2WKLED-B	2-Wire, Horn Strobe, Ceiling, White, Bilingual
L-Series with LED Outdoor Strobes	
SGRKLED	Compact Strobe, Wall, Red
SGRKLED-P	Compact Strobe, Wall, Red, Plain
SGRKLED-B	Compact Strobe, Wall, Red, Bilingual
SGWKLED	Compact Strobe, Wall, White
SGWKLED-P	Compact Strobe, Wall, White, Plain
SGWKLED-B	Compact Strobe, Wall, White, Bilingual
SCRKLED	Strobe, Ceiling, Red
SCRKLED-P	Strobe, Ceiling, Red, Plain
SCRKLED-B	Strobe, Ceiling, Red, Bilingual
SCWKLED	Strobe, Ceiling, White
SCWKLED-P	Strobe, Ceiling, White, Plain
SCWKLED-B	Strobe, Ceiling, White, Bilingual
L-Series Outdoor Horns	
HGRKL	Compact Horn, Red
HGRKL-B	Compact Horn, Red, Bilingual

Model	Description
LED Lenses	
LENS-A3	Lens LED Amber Wall/Ceiling
LENS-B3	Lens LED Blue Wall/Ceiling
LENS-G3	Lens LED Green Wall/Ceiling
LENS-R3	Lens LED Red Wall/Ceiling
Accessories	
SBBGRL	Compact Wall Surface Mount Back Box, Red
SBBGWL	Compact Wall Surface Mount Back Box, White
SBBCRL	Ceiling Surface Mount Back Box, Red
SBBCWL	Ceiling Surface Mount Back Box, White

Notes for L-Series With LED Outdoor Horn Strobes and Strobes:

All -P models have a plain housing (no "FIRE" marking on cover).
 All -SP models have "FUEGO" marking on cover.
 All -ALERT models have "ALERT" marking on cover.
 All -B models have "FIRE/FEU" marking on cover for use in Canadian applications.

3825 Ohio Avenue • St. Charles, IL 60174 USA
 Phone: 800-SENSOR2 • Fax: 630-377-6495
www.systemsensor.com

3333 Unity Drive, Mississauga, ON L5L 3S6 Canada
 Phone: 800-SENSOR2 • Fax: 905-812-0771
www.systemsensor.ca

System Sensor® is a registered trademark
 of Honeywell International, Inc.



©2024 System Sensor.
 Product specifications subject to change without notice. Visit www.systemsensor.com
 for current product information, including the latest version of this data sheet.
 AVDS-62173.A • 08/29/2024

ACERBOX

BY SPACE AGE ELECTRONICS

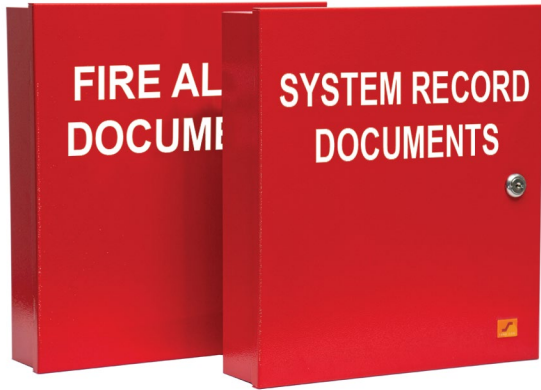

FAD/SRD ACE-11

Document Boxes

Store important system documents in a secure location with a cabinet built specifically to meet the requirements of NFPA72 7.7.2.1, NFPA72 7.7.2.3, NFPA72 7.7.2.5, and NFPA72 23.2.2.1.

Select models include our innovative 8GB flash drive slide tab that allows the user to select a USB-C or Micro USB connector to access records electronically per NFPA72 7.5.6.7.1 and NFPA72 7.5.6.7.2.



FEATURES

- 18 gauge cold rolled steel construction with red or black powder coat and white lettering
- Dimensions are 12" wide x 13" tall and 3" deep
- Liftaway hinge
- Removable document holder with two key ring hooks and business card bracket
- Slide tab allows user to select USB-C or Micro USB connector to download from 8GB digital flash memory



SPECIFICATIONS

The FAD and SRD Documents Box shall be UL Listed, constructed of 18 gauge cold rolled steel. It shall have a powder coat finish. The cover shall be permanently screened with 1" high lettering "FIRE ALARM DOCUMENTS" or "SYSTEM RECORD DOCUMENTS" with white indelible ink. The access door shall be locked with a 3/4" barrel lock and there will be a liftaway hinge. Models with digital storage will have a minimum of 8 gigabyte digital flash memory drive with a slide tab that allows user to select USB-C or Micro USB connector for uploading and downloading information. The enclosure will supply 4 mounting holes. Inside will accommodate standard 8 1/2" x 11" manuals, three-ring binders, and document records. The enclosure shall also provide 2 key ring holders with a location to mount standard business cards for key contact personnel.

CUSTOM BRANDING AVAILABLE



DIMENSIONS

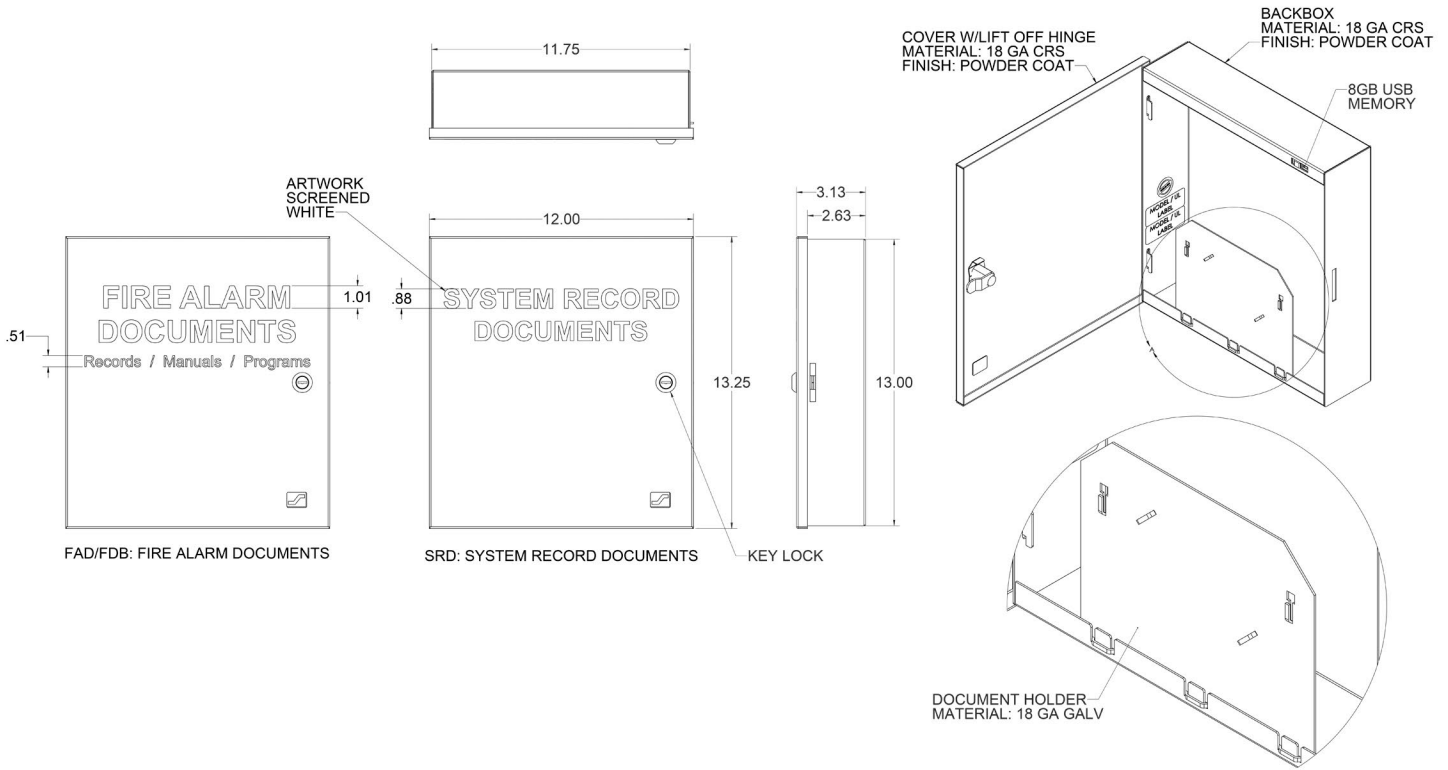

ORDERING INFORMATION

P/N#	Cover Text	Color	Custom Screening	USB Storage
SSU00672	Fire Alarm Documents	Red	No	No
SSU00673	Fire Alarm Documents	Red	Yes	No
SSU00685	Fire Alarm Documents	Red	No	Yes
SSU00686	Fire Alarm Documents	Red	Yes	Yes
SSU00689	System Record Documents	Red	No	Yes
SSU00690	System Record Documents	Red	Yes	Yes
SSU01672C	Fire Alarm Documents	Black	Yes	No
SSU01689	System Record Documents	Black	No	Yes
SSU01690	System Record Documents	Black	Yes	Yes



Features

- 120 VAC
- 10KA Short Circuit Current Rating
- ANSI/UL Listed 1449 4th Edition, Type 2
- CSA C22.2 No. 269.2-17 2nd edition, Type 2
- Acerbox ELOCK Circuit Lockout Kit included per NFPA 72 2013 10.6.5.2
- Surface or conduit mounting
- Diagnostic indicator light
- Self restoring
- 3 Wire device (18" length)

An ideal choice for your 120VAC applications, the E120V-GT maintains system integrity and protects against transients introduced into electrical lines via poor atmospheric and utility conditions as well as internally generated inductive loads.

Not only is the E-120V-GT robust enough to absorb a spike, but to also clamp long enough to trip the branch circuit breaker and still be functional for additional surges. Reduce downtime associated with power surges and lightning strikes, prevent interruption of recurring monthly revenue based systems, and eliminate non-billable service calls and expensive repairs by protecting your equipment with this invaluable device that satisfies NFPA72 10.6.5.5 and NFPA70 760.33.

Applications

- Fire alarm control panels
- Mass notification systems
- Dedicated branch circuits
- Amplifiers, motors, pumps, and power boosters

Specifications

All 120 VAC equipment will have Transient Voltage Surge Suppression (TVSS) protection manufactured by Space Age Electronics, Inc., part number E120V-GT. The unit shall be ANSI/UL listed to standard 1449, 4th edition and will be labeled clearly with indelible ink. Can be attached via the 3/4" rigid coupling, or surface mounted via the 2 external mounting holes. The unit shall have thermal fuses to protect against fire in short circuit conditions and will have 18" long, 14 gauge wires (3x) with a green ground wire. The enclosure will be a non dielectric material UL94 QMFZ2/8 grade material providing UV protection. The unit shall provide visual indication (LED) that unit is protecting and functioning.



Performance Specifications

Short Circuit Current Rating (SCCR): 10kA
Enclosure Material: UL94 QMFZ2/8 (green)
VPR=700 (L-N) 700 (L-G) 600 (N-G) Capacitance: < 2,000 pf
Clamping Response Time: < 5 nanoseconds
Current: Non-Load Bearing
Max Operating Voltage (MCOV): 140VAC, 50/60 Hz
Design: Thermally Fused Hybrid
Operation Indicators: LED
Max Surge Current: 25kA
Energy Dissipation: 500J
Clamping Voltage: 230V RMS

Operating Specifications

Service Voltage: 120VAC Single Phase
Circuits Protected: L-N L-G N-G
Connection Type: Hardwired
Installation Configuration: Parallel

Compliance Specifications

UL Listed: 1449 4th Edition - VZCA
File Number: E319370 Vol. 1 Sec. 1

Dimensions

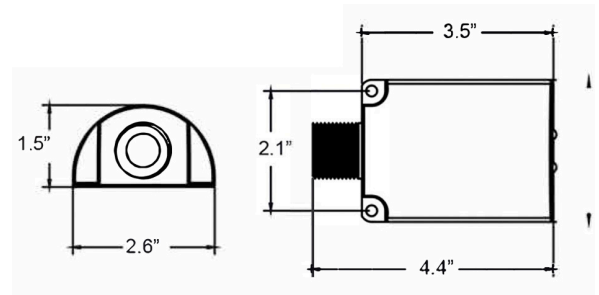

Wiring Diagram

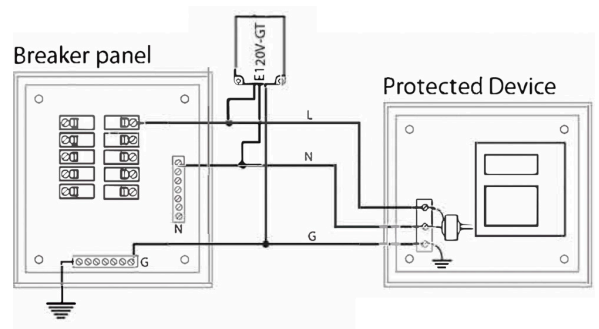

Ordering Information

P/N# E120V-GT
120V Hybrid Surge Protection Device (ELOCK Circuit Lockout Kit included)

P/N# ELOCK-FA
Acerbox ELOCK Circuit Lockout Kit

ACERBOX

BY SPACE AGE ELECTRONICS

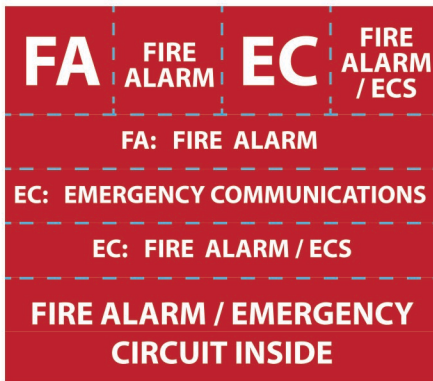

ELOCK-FA CIRCUIT LOCKOUT KIT

- Circuit lockout tab
- Hex key
- Breaker, legend, and door labels

NFPA 2016 CODE COMPLIANCE

- 10.6.5.2 Circuit Identification and Accessibility.
 - 10.6.5.2.1 The location of the branch circuit disconnecting means shall be permanently identified at the control unit.
 - 10.6.5.2.2 System circuit disconnecting means shall be permanently identified as to its purpose in accordance with the following:
 - (1) "FIRE ALARM" for fire alarm systems
 - (2) "EMERGENCY COMMUNICATIONS" for emergency communications systems
 - (3) "FIRE ALARM/ECS" for combination fire alarm and emergency communications systems
 - 10.6.5.2.3 For fire alarm and/or signaling systems, the circuit disconnecting means shall have a red marking.
 - 10.6.5.2.4 The red marking shall not damage the overcurrent protective devices or obscure the manufacturer's markings.
 - 10.6.5.2.5 The circuit disconnecting means shall be accessible only to authorized personnel.
- 10.6.5.3 Mechanical Protection. The branch circuit(s) and connections shall be protected against physical damage.
- 10.6.5.4 Circuit Breaker Lock. Where a circuit breaker is the disconnecting means, a listed breaker locking device shall be installed.



PS-12180

12V 18.0 AH @ 20-hr.
12V 17.1 AH @ 10-hr.

Rechargeable Sealed Lead Acid Battery PS – General Purpose Series

TERMINALS: (mm)

F2: Quick disconnect tabs, 0.250" x 0.032" – Mate with AMP. INC FASTON "250" series

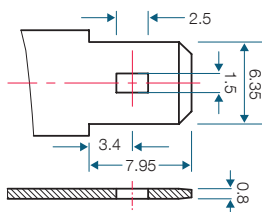

Torque – Not Applicable

NB2: Tin plated brass post with 'Nut & Bolt' fasteners

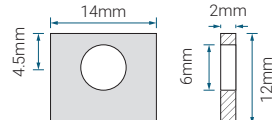

Torque: 3.9~5.4 Nxm

T12: Threaded insert with 5mm stud fastener

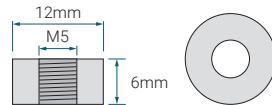

Torque: 2.0~3.0 Nxm

DIMENSIONS: inch (mm)

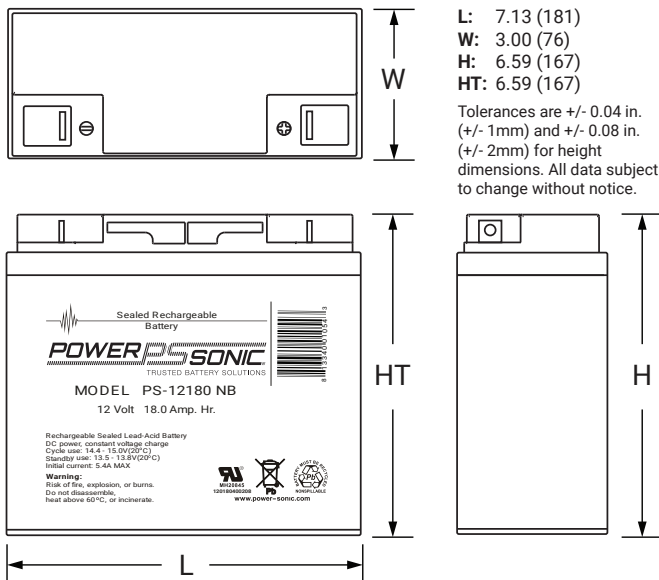

GLOBAL HEADQUARTERS (USA AND INTERNATIONAL EXCLUDING EMEA)

Power-Sonic Corporation
365 Cabela Dr Suite 300,
Reno, Nevada 89523
USA
T: +1 619 661 2020
E: customer-service@power-sonic.com

POWER-SONIC EMEA (EMEA – EUROPE, MIDDLE EAST AND AFRICA)

Smitspol 4, 3861 RS Nijkerk,
The Netherlands
T NL: + 31 33 7410 700
T UK: + 44 1268 560 686
T FR: + 33 344 32 18 17
E: salesEMEA@power-sonic.com

FEATURES

- 5 year design life
- Absorbent Glass Mat (AGM) technology for superior performance
- Valve regulated, maintenance free spill proof construction
- Power/volume ratio yielding excellent energy density
- Rugged vibration and impact resistant ABS case and cover
- Gas recombination technology

APPROVALS

- Approved for transport by air. D.O.T., I.A.T.A., F.A.A. and C.A.B. certified
- U.L. recognized
- ISO9001:2015 – Quality management systems

PERFORMANCE SPECIFICATIONS

Nominal Voltage	12 volts (6 cells)
Nominal Capacity	
20-hr. (900mA to 10.50 volts)	18.00 AH
10-hr. (1.71A to 10.50 volts)	17.10 AH
5-hr. (3.06A to 10.20 volts)	15.30 AH
1-hr. (11.5A to 9.60 volts)	11.50 AH
Approximate Weight	12.32 lbs. (5.6 kg)
Internal Resistance (approx.)	10.5 milliohms
Max Short-Duration Discharge Current (5 Sec.)	270.0 amperes
Shelf Life (% of nominal capacity at 68°F (20°C))	
1 Month	92%
3 Month	90%
6 Month	80%
Operating Temperature Range	
Charge	5°F (-15°C) to 122°F (50°C)
Discharge	5°F (-15°C) to 104°F (40°C)
Case	ABS Plastic
Power Sonic Chargers	PSC-122000A-C PSC-122000-PC PSC-124000-PC PSC-124000A-C

PS-12180 12V 18.0 AH @ 20-hr.
12V 17.1 AH @ 10-hr.

Rechargeable Sealed Lead Acid Battery
PS – General Purpose Series

SHELF LIFE & STORAGE

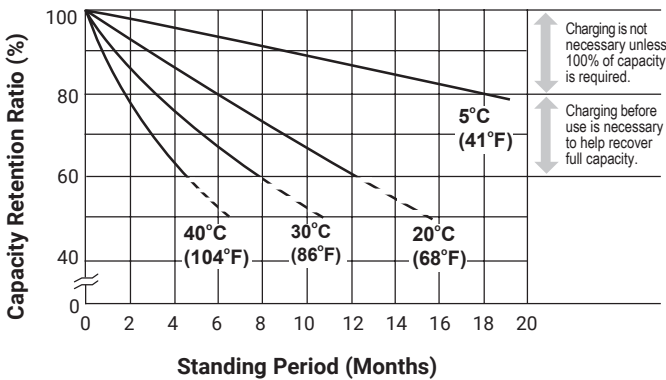

LIFE CHARACTERISTICS IN STAND-BY USE

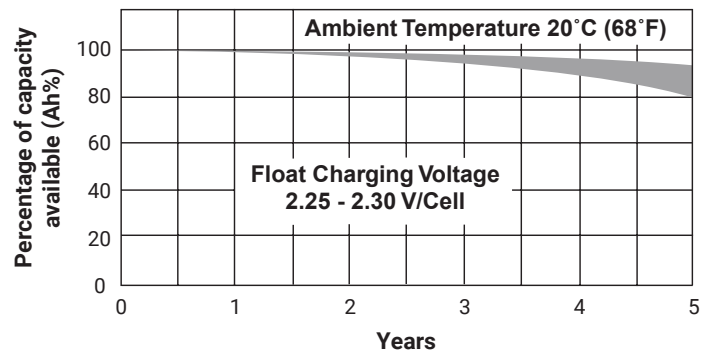

CHARGING

Cycle Applications: Apply constant voltage charge at 2.35v/c – 2.45v/c (14.1 – 14.7v for 12v Monobloc) at 20°C. Initial charging current should be set at less than 0.25C Amps. Switch to float charge to avoid overcharging.

“Float” or “Stand-By” Service: Apply constant voltage charge of 2.25v/c – 2.30v/c (13.5 to 13.8 volts for 12v Monobloc) at 20°C. When held at this voltage, the battery will seek its own current level and maintain itself in a fully charged condition.

Temperature Compensation: Charging Voltage for both Cyclic and Standby applications should be regulated in relation to ambient temperature. As temperature rises charging voltage should be reduced to prevent overcharge and increased as temperature falls to avoid undercharge.

For further charging information including temperature compensation factors, see Power Sonic Technical Manual/ Power Sonic Charger specifications.

APPLICATIONS

- General purpose
- Medical
- Emergency lighting
- Fire and security

GLOBAL HEADQUARTERS (USA AND INTERNATIONAL EXCLUDING EMEA)

Power-Sonic Corporation
365 Cabela Dr Suite 300,
Reno, Nevada 89523
USA
T: +1 619 661 2020
E: customer-service@power-sonic.com

POWER-SONIC EMEA (EMEA – EUROPE, MIDDLE EAST AND AFRICA)

Smitspol 4, 3861 RS Nijkerk,
The Netherlands
T NL: + 31 33 7410 700
T UK: + 44 1268 560 686
T FR: + 33 344 32 18 17
E: salesEMEA@power-sonic.com

CHARGERS

Power Sonic offers a wide range of chargers suitable for batteries with a variety of capacities.

Please refer to our website for more information on our switch mode and transformer type chargers.

Please contact our technical department for advice if you have difficulty in locating a suitable charger.

FURTHER INFORMATION

Please refer to our website www.power-sonic.com for a complete range of useful downloads, such as product catalogs, material safety data sheets (MSDS), ISO certification, etc.





PS-1280

12V 8.0 AH @ 20-hr.
12V 7.2 AH @ 10-hr.

Rechargeable Sealed Lead Acid Battery PS – General Purpose Series

TERMINALS: (mm)

F1: Quick disconnect tabs,
0.187" x 0.032" – Mate with
AMP. INC. FASTON "187" series

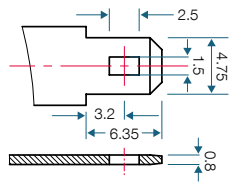

Torque – Not Applicable

F2: Quick disconnect tabs,
0.250" x 0.032" – Mate with
AMP. INC FASTON "250" series

OR

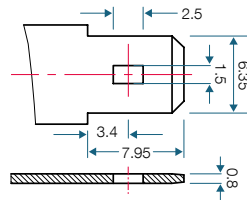

Torque – Not Applicable

DIMENSIONS: inch (mm)



L: 5.95 (151)
W: 2.56 (65)
H: 3.72 (94.5)
HT: 3.90 (99)

Tolerances are +/- 0.04 in.
(+/- 1mm) and +/- 0.08 in.
(+/- 2mm) for height
dimensions. All data subject
to change without notice.

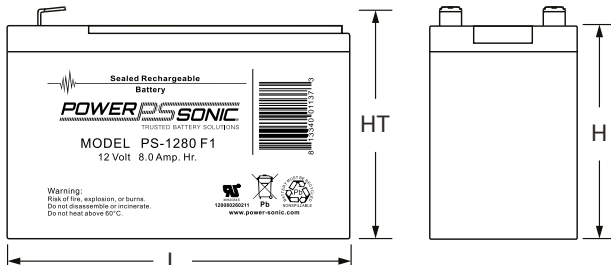

CORPORATE HEADQUARTERS (USA AND INTERNATIONAL EXCLUDING EMEA)

Power-Sonic Corporation
7550 Panasonic Way, San Diego,
California 92154
T: +1 (619) 661 2020
F: +1 (619) 661 3650
E: customer-service@power-sonic.com

POWER-SONIC EUROPE LIMITED (EMEA – EUROPE, MIDDLE EAST AND AFRICA)

3 Buckingham Square,
Hurricane Way, Wickford,
Essex SS11 8YQ
T: +44 (0)1268 560686
F: +44 (0)1268 560902
E: salesEMEA@power-sonic.com

FEATURES

- Absorbent Glass Mat (AGM) technology for superior performance
- Valve regulated, maintenance free spill proof construction
- Power/volume ratio yielding excellent energy density
- Rugged vibration and impact resistant ABS case and cover
- Gas recombination technology
- 5 year design life

APPROVALS

- Approved for transport by air. D.O.T., I.A.T.A., F.A.A. and C.A.B. certified
- U.L. recognized
- ISO9001:2015 – Quality management systems

PERFORMANCE SPECIFICATIONS

Nominal Voltage	12 volts (6 cells)
Nominal Capacity	
20-hr. (400mA to 10.50 volts)	8.00 AH
10-hr. (720mA to 10.50 volts)	7.20 AH
5-hr. (1.33A to 10.20 volts)	6.65 AH
1-hr. (4.90A to 9.00 volts)	4.90 AH
Approximate Weight	5.60 lbs. (2.54 kg)
Internal Resistance (approx.)	18.0 milliohms
Max Short-Duration Discharge Current (10 Sec.)	80.0 amperes
Shelf Life (% of nominal capacity at 68°F (20°C))	
1 Month	97%
3 Month	91%
6 Month	83%
Operating Temperature Range	
Charge	5°F (-15°C) to 122°F (50°C)
Discharge	-4°F (-20°C) to 140°F (60°C)
Case	ABS Plastic
Power Sonic Chargers	PSC-12800A-C PSC-121000-PC PSC-122000A-C

PS-1280 12V 8.0 AH @ 20-hr.
12V 7.2 AH @ 10-hr.

Rechargeable Sealed Lead Acid Battery
PS – General Purpose Series

SHELF LIFE & STORAGE

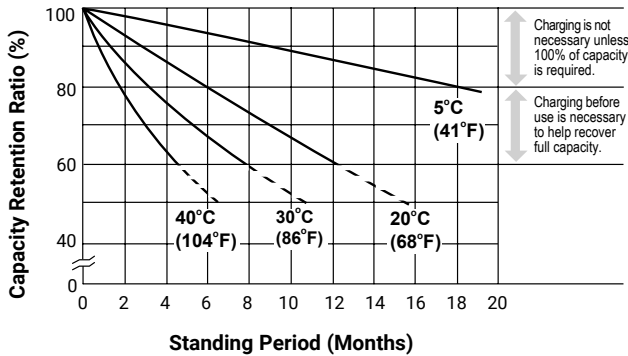

LIFE CHARACTERISTICS IN STAND-BY USE

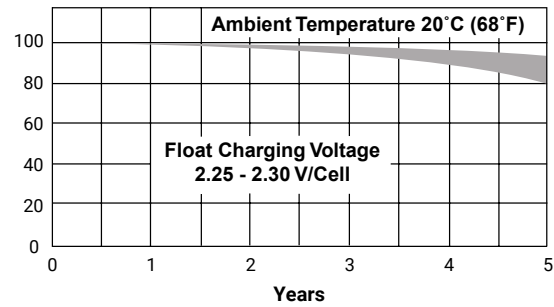

CHARGING

Cycle Applications: Apply constant voltage charge at 2.35v/c – 2.45v/c (14.1 – 14.7v for 12v Monobloc) at 20°C. Initial charging current should be set at less than 0.25C Amps. Switch to float charge to avoid overcharging.

“Float” or “Stand-By” Service: Apply constant voltage charge of 2.25v/c – 2.30v/c (13.5 to 13.8 volts for 12v Monobloc at 20°C. When held at this voltage, the battery will seek its own current level and maintain itself in a fully charged condition.

Temperature Compensation: Charging Voltage for both Cyclic and Standby applications should be regulated in relation to ambient temperature. As temperature rises charging voltage should be reduced to prevent overcharge and increased as temperature falls to avoid undercharge.

For further charging information including temperature compensation factors, see Power Sonic Technical Manual/ Power Sonic Charger specifications.

APPLICATIONS

- General purpose
- Medical
- Emergency lighting
- Fire and security

CORPORATE HEADQUARTERS
(USA AND INTERNATIONAL EXCLUDING EMEA)

Power-Sonic Corporation
7550 Panasonic Way, San Diego,
California 92154
T: +1 (619) 661 2020
F: +1 (619) 661 3650
E: customer-service@power-sonic.com

POWER-SONIC EUROPE LIMITED
(EMEA – EUROPE, MIDDLE EAST AND AFRICA)

3 Buckingham Square,
Hurricane Way, Wickford,
Essex SS11 8YQ
T: +44 (0)1268 560686
F: +44 (0)1268 560902
E: salesEMEA@power-sonic.com

CHARGERS

Power Sonic offers a wide range of chargers suitable for batteries with a variety of capacities.

Please refer to our website for more information on our switch mode and transformer type chargers.

Please contact our technical department for advice if you have difficulty in locating a suitable charger.

FURTHER INFORMATION

Please refer to our website www.power-sonic.com for a complete range of useful downloads, such as product catalogs, material safety data sheets (MSDS), ISO certification, etc.





SS-Series Intelligent Detectors

The System Sensor SS-Series intelligent photoelectric and thermal detectors with integral communication provide point location for alarm communication and selective maintenance.



Features

- UL 268 7th Edition, UL 521, and/or UL 268A certified
- New modern profile
- Analog communications
- Low standby current
- Rotary address switches
- Dual LEDs for 360° visibility
- Expanded color options

SS-Series smoke detectors are intelligent (addressable) detectors with point ID capability that enable each detector address to be set with rotary address switches providing exact device locations. SS-Series detectors support current SK, LiteSpeed™ and SS Protocol systems. Refer to the Addressable Detector and Sounder Base Compatibility Chart or the Intelligent Control Panel SLC Wiring Manual for specific panel compatibility. Detector sensitivity is continually monitored and reported to the fire alarm control panel. The modern design and expanded color options support contemporary aesthetic demands. In addition, each detector is constructed for exceptional installation and maintenance efficiency.

The System Sensor **SS-PHOTO** photoelectric detector's re-designed optical sensing chamber is engineered to sense smoke produced by a wide range of combustion sources in accordance with more stringent code standards. The sensitivity of SS-Series detectors can be programmed using the control panel software to suit the environment. The **SS-PHOTO-R** photoelectric detector is also remote test capable for use with a DNR (DNRW) duct smoke detector. The **SS-PHOTO-T** multi-sensor detector offers either photoelectric detection or thermal detection through dual electronic thermistors at 135°F (57°C) fixed temperature thermal sensing.

SS-Series thermal detectors provide cost-effective, intelligent property protection with a UL 521 listing: the **SS-HEAT** offers 135°F (57°C) fixed thermal detection; the **SS-HEAT-ROR** offers 135°F (57°C) fixed and rate-of-rise thermal detection; the **SS-HEAT-HT** provides fixed high-temperature detection at 190°F.

Agency Listings



SS-PHOTO Series: S911
SS-HEAT Series: S2101



SS-PHOTO Series:
7272-1653:0529
SS-HEAT Series:
7270-1653:0528

SS-Series Intelligent Detector Specifications

Physical/Operating Specifications	
Height	2.0 inches (51 mm)
Diameter	6.2 inches (156 mm) installed in B300-6 base; 4.1 inches (104 mm) installed in B501-WHITE/-IV/-BL base
Shipping Weight	3.4 oz (95 g)
Operating Temperature Range	Photo: 32°F to 122°F (0°C to 50°C) Photo with Remote Test: 32°F to 122°F (0°C to 50°C); -4°F to 158°F (-20°C to 70°C) in duct applications Photo with Thermal: 32°F to 115°F (0°C to 47°C) Heat - Fixed-temperature: -4°F to 115°F (-20°C to 47°C) Heat - Rate of Rise (ROR): -4°F to 115°F (-20°C to 47°C) Heat - High Temperature: -4°F to 150°F (-20°C to 66°C)
UL-Listed Velocity Range	Photo, Photo with Thermal, Photo with Remote Test: 0 to 4,000 fpm (0 to 1,219 m/minute) (suitable for installation in ducts)
Operating Humidity Range	10% to 93% non-condensing
Thermal Ratings	Fixed Temperature Setpoint: 135°F (57°C) Rate-of-Rise Detection: 15°F/min. (8.3°C/min.) High Temperature Heat: 190°F (88°C)
Sensitivity Range	SS-PHOTO, SS-PHOTO-R, SS-PHOTO-T: Open area 2.86–5.0%/FT. Special Application 0.5–2.86%/FT.
Electrical Specifications	
Voltage Range	15 to 32 VDC peak
Operating Current @ 24 VDC	200 uA (one communication every 5 seconds with green LED blink on communication)
Maximum Current	4.5 mA @ 24 VDC (one communication every 5 seconds with amber LED solid on)
Maximum Alarm Current	2 mA @ 24 VDC (one communication every 5 seconds with red LED solid on)

Ordering Information

Part No.			Description
White	Ivory	Black	
SS-PHOTO	—	—	Photoelectric smoke detector
SS-PHOTO-R	—	—	Photoelectric smoke detector, remote test capable, for use with DNR(W) duct smoke detectors
SS-PHOTO-T	—	—	Photoelectric smoke detector with thermal
SS-HEAT	—	—	Fixed temperature thermal detector
SS-HEAT-ROR	—	—	Fixed temperature and Rate-of-rise thermal detector
SS-HEAT-HT	—	—	High temperature thermal detector
Bases			
B501-WHITE	B501-IV	B501-BL	4" Mounting base
B501-WHITE-BP	—	—	4" Mounting base, bulk pack (10)
B300-6	B300-6-IV	—	6" Flanged mounting base
B300-6-BP	—	—	6" Flanged mounting base, bulk pack (10)
B200S-WH	B200S-IV	—	Intelligent addressable sounder base
B200S-LF-WH	B200S-LF-IV	—	Intelligent addressable sounder base, low-frequency
B200SR	B200SR-IV	—	Intelligent sounder base
B200SR-LF	B200SR-LF-IV	—	Intelligent sounder base, low frequency
B224RB	B224RB-IV	—	Relay base
B224BI	B224BI-IV	—	Isolator base
Accessories			
—	SMB600	—	Surface Mounting Kit (flanged)
TR300	TR300-IV	—	Trim ring
CK300	CK300-IV	CK300-BL	Color Kit (includes cover and trim ring)
—	RA100Z	—	RA100Z Remote LED annunciator
M02-04-00	—	—	Detector test magnet
M02-09-00	—	—	Telescoping test magnet

Accessories

RA100Z
Remote LED
Annunciator



CK300-BL
Color Kit



TR300
Trim Ring

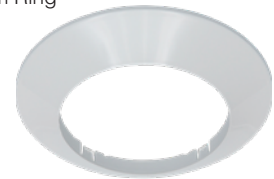

System Sensor® is a registered trademark of
and LiteSpeed™ is a trademark of
Honeywell International, Inc.



3825 Ohio Avenue • St. Charles, IL 60174
Phone: 800-SENSOR2 • Fax: 630-377-6495

©2024 System Sensor.
Product specifications subject to change without notice. Visit systemsensor.com
for current product information, including the latest version of this data sheet.
SPDS-62165 Rev. B • 5/8/2024