



Puyallup AOB Construction Stormwater Pollution Prevention Plan (SWPPP)

Prepared for
Puyallup Mixed Use, LLC

March 2026

Puyallup AOB Construction Stormwater Pollution Prevention Plan (SWPPP)

Prepared for

Puyallup Mixed Use, LLC

Prepared by

Parametrix

1019 39th Avenue SE, Suite 100

Puyallup, WA 98374

T. 253.604.6600 F. 1.206.649.6353

www.parametrix.com

March 2026 | 217-9504-001

Citation

Parametrix. 2026. Puyallup AOB Construction Stormwater Pollution Prevention Plan (SWPPP). Prepared for Puyallup Mixed Use, LLC by Parametrix, Puyallup, Washington. March 2026.

Contents

1. Project Description	1
1.1 Location.....	1
1.2 Project Overview	1
2. Existing Conditions	1
2.1 Existing Site Topography and Vegetation.....	1
2.2 Existing Drainage System.....	1
2.3 Adjacent Areas	1
3. CRITICAL AREAS	2
4. EROSION PROBLEM AREAS	2
5. CONSTRUCTION STORMWATER POLLUTION PREVENTION ELEMENTS	2
5.1 Objective of the Stormwater Pollution Prevention Plan	2
5.2 Summary of Elements	2
5.3 Element #1: Preserve Vegetation/Mark Clearing Limits.....	2
5.4 Element #2: Establish Construction Access	3
5.5 Element #3: Control Flow Rates	3
5.6 Element #4: Install Sediment Controls	4
5.7 Element #5: Stabilize Soils	4
5.8 Element #6: Protect Slopes	5
5.9 Element #7: Protect Drain Inlets	5
5.10 Element #8: Stabilize Channels and Outlets	5
5.11 Element #9: Control Pollutants.....	6
5.12 Element #10: Control Dewatering.....	6
5.13 Element #11: Maintain BMPs.....	7
5.14 Element #12: Manage the Project	7
5.14.1 Phasing of Construction	7
5.14.2 Seasonal Work Limitations.....	8
5.14.3 Inspection and Monitoring.....	8
5.14.4 Maintenance of the SWPPP	8
5.15 Element #13: Protect Low-Impact Development (LID) BMPs	9

Contents (Continued)

6. ESTIMATED CONSTRUCTION SCHEDULE	9
7. REPORTING AND RECORD KEEPING.....	9
7.1 Record Keeping	9
7.1.1 Site Logbook.....	9
7.1.2 Records Retention	9
7.1.3 Updating the SWPPP.....	10
8. SITE PLAN.....	10

TABLES

Table 1 Construction Schedule	9
-------------------------------------	---

APPENDICES

- A Erosion & Sediment Control BMPs

Acronyms and Abbreviations

AC	Acres
BMPs	best management practices
CESCL	Certified Erosion and Sediment Control Lead
CSWGP	Construction Stormwater General Permit
CSWPPP	Construction Stormwater Pollution Prevention Plan
CWA	Clean Water Act
CY	Cubic Yards
DMR	Discharge Monitoring Report
Ecology	Washington State Department of Ecology
EPA	United States Environmental Protection Agency
GULD	General Use Level Designation
LID	low-impact development
NPDES	National Pollutant Discharge Elimination System
pH	Power of Hydrogen
SPCC	Spill Prevention, Control, and Countermeasures
SF	Square Feet
su	Standard Units
SWMMWW	2024 Stormwater Management Manual for Western Washington
TMDL	total maximum daily load
TESC	Temporary Erosion and Sediment Control
WAC	Washington Administrative Code
WSDOT	Washington Department of Transportation

1. Project Description

1.1 Location

The Puyallup AOB (Project) is a mixed-use development project owned by Puyallup Mixed Use, LLC. The project site is located on parcel 5745001371 between W Pioneer Avenue and SW 3rd Street in Puyallup, WA located in Pierce County. The site is in the Central business district core zone (CBD-Core) zone district and the Pedestrian Oriented Commercial (POC) Comprehensive Plan designated area.

1.2 Project Overview

The Project proposes developing a 5-story apartment building with 140 residential units, covered parking, and retail space while installing new utility service connections, public frontage improvements, amenities, and open space areas as part of the development. The Project area will be approximately 1.11 acres of development that includes constructing the following:

- 140 residential units
- 2,295 square feet of retail space
- Domestic water and sewer service connections
- Dedicated fire suppression services
- Frontage improvements along SW 3rd Street and Pioneer W Pioneer Avenue

2. Existing Conditions

2.1 Existing Site Topography and Vegetation

The existing site is a surface parking lot that is almost entirely covered in asphalt with a few landscape islands located throughout the center and perimeter of the lot. It is extremely flat with low points and catch basin inlets spaced throughout.

2.2 Existing Drainage System

The 1.11-acre lot is 93% impervious surface with asphalt parking areas and drive aisles covering the site. Runoff is collected in catch basins at low points throughout the property, and the stormwater is conveyed off-site from these existing inlets into the existing City storm drain system ultimately outfalling into the Puyallup River. Due to the flat land surrounding the site, there is no anticipated run-on.

2.3 Adjacent Areas

Nearby land use includes surface parking lots, public parks, churches, schools, single and multi-family housing, shopping, and restaurants.

3. CRITICAL AREAS

There are no wetlands or critical areas in the immediate vicinity of the project site.

4. EROSION PROBLEM AREAS

There are no specific areas identified as erosion prone or higher susceptibility. The primary anticipated erosion is sediment laden runoff as uncovered areas of the site encounter rainfall. Precautions and observations of exposed surface will be critical to minimize erosion and prevent/reduce stormwater pollution. Depending on the depth of excavation needed to prepare the structure's foundation, retaining the excavated footprint should be monitored for stability and any erosion tracking off-site.

5. CONSTRUCTION STORMWATER POLLUTION PREVENTION ELEMENTS

5.1 Objective of the Stormwater Pollution Prevention Plan

The purpose of a Construction Stormwater Pollution Prevention Plan (SWPPP) is to describe the potential for erosion, sediment, and pollution problems on a construction project. The SWPPP also explains and illustrates the measures to be taken on the construction site to control these problems. This SWPPP is prepared according to the guidance of the Washington State Department of Ecology (Ecology) 2024 Stormwater Management Manual for Western Washington (SWMMWW). The SWMMWW describes thirteen necessary elements of construction stormwater pollution prevention. These thirteen elements include: preserve vegetation / mark clearing limits, establish construction access, control flow rates, install sediment controls, stabilize soils, protect slopes, protect drain inlets, stabilize channels and outlets, control pollutants, control dewatering, maintain BMPs, manage the project, and protect low impact development BMPs. These elements have been addressed as follows.

5.2 Summary of Elements

The BMPs listed in this report, or their equivalent, are required. Any revisions by the contractor to the BMPs listed in the SWPPP shall be approved by the Engineer. Therefore, if the contractor does not require a BMP or needs to modify a BMP, the contractor shall document the reasons and update the SWPPP to match what is being implemented in the field. A copy of the construction stormwater BMPs can be found in Appendix A.

5.3 Element #1: Preserve Vegetation/Mark Clearing Limits

The clearing limits shall be marked prior to any clearing to restrict clearing to the approved limits. A high visibility fence shall be installed to delineate the extents of construction activities in accordance with BMP 103. No clearing or grubbing will begin until the limits have been delineated. The Contractor shall use best judgement selecting of the type of fencing (high orange fencing, chain-link with placards, or high visible silt fence) to be utilized.

Installation Schedule: Summer 2026

Inspection and Maintenance Plan:

- If the fencing or clearing limits are observed to be damaged or visibility is reduced, it shall be repaired and/or replaced immediately and visibility restored.
- Fence or clearly mark areas around trees that are to be saved at least to the extents of the dripline.

Responsible Staff:

- CESCL

5.4 Element #2: Establish Construction Access

A stabilized construction access is required to reduce the amount of sediment transported onto paved roads outside the project site. This stabilized construction entrance shall be constructed with a quarry spall pad in accordance with the requirements of BMP C105.

If sediment is tracked off-site, public roads shall be cleaned thoroughly at the end of each day, or more frequently during wet weather. Sediment shall be removed from roads by shoveling or pickup sweeping and shall be transported to a controlled sediment disposal area. Street washing will be allowed only after sediment is removed. Should tracking of sediments off-site continue to occur, wheel washes may be needed in accordance with BMP C106.

Installation Schedule: Summer 2026

Inspection and Maintenance Plan:

- If sediment or quarry spalls are observed being tracked onto pavement, then alternative measures to keep the street free of sediment shall be used. This may include replacement/cleaning of existing quarry spalls, street sweeping, an increase in the dimensions of the entrance, or the installation of a wheel wash.
- If a wheel wash is installed, the wheel wash should start out the day with fresh water, and the wash water should be changed a minimum once per day. The Contractor shall determine the frequency of changing the wash water.
- Inspect stabilized areas regularly, especially after large storm events. Crushed rock, gravel base, etc. shall be added as required to maintain a stable driving surface and to stabilize areas that have eroded.

Responsible Staff:

- CESCL

5.5 Element #3: Control Flow Rates

Stormwater runoff shall be observed during storm events to ensure flow rates are not increased to cause erosion to off-site locations. There are no proposed detention/retention facilities associated with the project. Straw wattles (BMP C235) will be placed intermittently throughout the site to dissipate stormwater flows from concentrated flow into dispersed segmental flows.

Installation Schedule: Fall/Winter 2026

Inspection and Maintenance Plan:

- Inspect wattles regularly, especially after large storm events.

Responsible Staff:

- CESCL

5.6 Element #4: Install Sediment Controls

To minimize the discharge of pollutants offsite, erosion and sediment controls will be installed along site perimeter. Stormwater runoff from disturbed areas shall be routed through an appropriate sediment removal BMP per the Contractor's best judgement prior to runoff discharging off-site.

The following BMPs may be implemented where appropriate:

- BMP C220 – Storm Drain Inlet Protectors
- BMP C230 – Straw Bale Barrier
- BMP C233 – Silt Fence
- BMP C235 – Straw Wattles
- BMP C240 – Sediment Trap
- BMP C 251 – Construction Stormwater Filtration

Installation Schedule: Summer 2026

Inspection and Maintenance Plan:

- Repair any damage immediately.
- Replace filter fabric that has deteriorated due to ultraviolet breakdown.

Responsible Staff:

- CESCL

5.7 Element #5: Stabilize Soils

All exposed and unworked soils shall be stabilized by application of effective BMPs, which protect the soil from the erosive forces of raindrop impact, flowing water, and from wind erosion. Site demolition schedule phasing shall be planned to reduce the amount of soil exposed during construction activity.

From October 1 through April 30, no soils shall remain exposed and un-worked for more than 2 days. From May 1 to September 30, no soils shall remain exposed and un-worked for more than 7 days. This condition applies to all soils on-site, whether at final grade or not. Soils to be stabilized at the end of shifts prior to holidays or weekends based on weather forecasts per Contractor's best judgement.

In areas where the soils will remain un-worked for more than 30 days or have reached final grade, plastic covering shall be used in accordance with BMP C123.

If the soil stockpile slope is 2H:1V or greater with at least 10 feet of vertical relief, nets, or blankets shall be used according to BMP C122. Dust control shall be used as needed to prevent wind

transport of dust from disturbed soil surfaces and in accordance with BMP C140. Contractor to utilize available non-potable water from on-site sources or provide water tanker in order to spray down disturbed soils to minimize dust produced from construction activities.

Installation Schedule: Summer/Fall 2026

Inspection and Maintenance Plan:

- Reseed any seeded areas that fail to establish at least 80 percent cover. If reseeding is ineffective, use an alternative method such as sodding, mulching, or nets/blankets to stabilize soils.
- Respray areas as needed to keep dust to a minimum.

Responsible Staff:

- CESCL

5.8 Element #6: Protect Slopes

There are no slopes within the project area that are anticipated to be prone to erosion or slope stability.

5.9 Element #7: Protect Drain Inlets

All storm drain inlets made operable during construction, as well as all existing structures within the project limits, shall be marked and protected so that stormwater runoff shall not enter the conveyance system without first being filtered or treated to remove sediment. Install catch basin sock filters or approved equal as shown on the TESC Plans and in accordance with BMP C220 or WSDOT standard I-40.20-00.

Contractor to prevent sediment and street wash water to enter storm drains without prior and adequate treatment.

Installation Schedule: Summer 2026

Inspection and Maintenance Plan:

- Inlets to be inspected weekly at a minimum and daily during storm events.
- Inlet protection devices shall be cleaned, removed, and replaced when sediment has filled one-third of the available storage (unless a different standard is specified by the product manufacturer).
- Do not wash sediment into storm drains while cleaning.

Responsible Staff:

- CESCL

5.10 Element #8: Stabilize Channels and Outlets

There are no natural drainage channels or outlets within the project area that are anticipated to be prone to erosion or slope stability as a result of the project.

5.11 Element #9: Control Pollutants

Cement/concrete and associated curing waters from concrete production are the primary pollutants anticipated. All pollutants, including waste materials and demolition debris, that occur on-site during construction shall be handled and disposed of in a manner that does not cause contamination of stormwater.

Maintenance and repair of heavy equipment and vehicles involving oil changes, hydraulic system drain down, solvent, and de-greasing cleaning operations, fuel tank drain down and removal, and other activities which may result in discharge or spillage of pollutants to the ground or into stormwater runoff must be conducted using spill prevention measures, such as drip pans. Emergency repairs may be performed on-site using temporary plastic placed beneath, and if it is raining, over the vehicle.

If a wheel wash is utilized, wastewater shall be treated by an on-site treatment system that prevents discharge to surface waters, sanitary sewers, or wetland areas. It may be combined with wastewater from concrete washout areas if properly disposed of at an off-site location or treatment facility.

Source control BMPs that will apply to this project include:

- A Spill Prevention Control and Countermeasures Plan (prepared by Contractor)
- BMP C251 - Construction Stormwater Filtration
- Concrete Washout Area
- Street Sweeping (as needed during construction by Contractor)

The following BMPs may be implemented where appropriate:

- BMP C151 – Concrete Handling
- BMP C152 – Sawcutting and Surfacing Pollution Prevention
- BMP C153 – Material Delivery, Storage, and Containment
- BMP C154 – Concrete and Washout Area

Installation Schedule: Fall 2026

Inspection and Maintenance Plan:

- Contaminated surfaces shall be cleaned immediately following any discharge or spill incident.
- Source control BMPs shall be utilized to prevent the likelihood of pollutants being introduced on-site.

Responsible Staff:

- CESCL

5.12 Element #10: Control Dewatering

If dewatering is required, dewatering water is to be treated similar to on-site stormwater runoff. It must be conveyed through appropriate BMPs prior to off-site discharge. On-site infiltration is the preferred option to manage dewatering waters. If no other options are available, the contractor shall

install a sedimentation tank on site for dewatered waters. The contractor will be required to coordinate with the City of Puyallup to permit discharging dewatering water into the sanitary main following sedimentation/filtration facilities as a last resort.

Installation Schedule: Fall 2026

Inspection and Maintenance Plan:

- Transport off site in a vehicle, such as a vacuum flush truck, for legal disposal.
- Observe the turbidity of the dewatering water to determine the appropriate BMP and discharge location.

Responsible Staff:

- CESCL

5.13 Element #11: Maintain BMPs

All temporary and permanent erosion and sediment control BMPs shall be maintained and repaired as needed to ensure continued performance of their intended function. All maintenance and repair shall be in accordance with BMPs.

Sediment control BMPs shall be inspected weekly or after a runoff-producing storm event during the dry season and daily during the wet season.

All temporary erosion and sediment control BMPs shall be removed within 30 days after final site stabilization is achieved, or after the temporary BMPs are no longer needed. Trapped sediment shall be removed or stabilized on-site. Disturbed soil areas resulting from removal of BMPs or vegetation shall be permanently stabilized.

The following BMPs may be implemented where appropriate:

- BMP C150 – Materials on Hand
- BMP C160 – Certified Erosion and Sediment Control Lead

Installation Schedule: Summer/Fall 2026

Inspection and Maintenance Plan:

- Inspect BMPs at regular intervals, especially following large storm events.

Responsible Staff:

- CESCL

5.14 Element #12: Manage the Project

5.14.1 Phasing of Construction

The project shall be phased where feasible in order to prevent, to the maximum extent practicable, the transport of sediment from the site during construction. The Contractor will install the aforementioned erosion and sediment control BMPs prior to any construction activities. BMPs will be installed and in place during and throughout the transition between phases as applicable. At the

completion of the demolition and site restoration, workers will do a final policing of the area, picking up any remaining debris, then remove the SWPPP control measures and security fencing.

5.14.2 Seasonal Work Limitations

From October 1 through April 30, clearing, grading, and other soil disturbing activities shall only be permitted if silt-laden runoff will be prevented from leaving the construction site.

The following activities are exempt from the seasonal clearing and grading limitations:

- Routine maintenance and necessary repair of erosion and sediment control BMPs;
- Routine maintenance of public facilities or existing utility structures that do not expose the soil or result in the removal of the vegetative cover to the soil; and
- Activities where there is 100 percent infiltration of surface water runoff within the site in approved and installed erosion and sediment control facilities.

5.14.3 Inspection and Monitoring

All BMPs shall be inspected, maintained, and repaired as needed to ensure continued performance of their intended function.

Sampling and analysis of the stormwater discharges from the construction site may be necessary to ensure compliance with standards.

Whenever inspection and/or monitoring reveals that the BMPs identified in the construction SWPPP are inadequate, due to the actual discharge of or potential to discharge a significant amount of any pollutant, the construction SWPPP shall be modified, as appropriate, in a timely manner.

Site inspections shall be conducted the identified CESCL. The CESCL must be on-site or on-call at all times during the duration of construction activities. The CESCL must examine stormwater visually for the presence of suspended sediment, turbidity, discoloration, and oil sheen, and it is upon the CESCL's evaluation of the effectiveness of BMPs to determine if it is necessary to install, maintain, or repair BMPs to improve quality of stormwater discharges.

The CESCL must inspect all areas disturbed by construction activities, all BMPs, and all stormwater discharge points at least once every calendar week and within 24 hours of any discharge from the site.

The CESCL may reduce this inspection frequency for temporary stabilized or inactive sites to once every calendar month through the duration of construction activities.

5.14.4 Maintenance of the SWPPP

The construction SWPPP shall be retained on-site or within reasonable access to the site. The construction SWPPP shall be modified by the Contractor and/or Engineer whenever there is a significant change in the design, construction, operation, or maintenance of any BMP.

The following BMPs may be implemented where appropriate:

- BMP C162 – Scheduling

5.15 Element #13: Protect Low-Impact Development (LID) BMPs

There are no LID elements within the project scope to protect.

6. ESTIMATED CONSTRUCTION SCHEDULE

Table 1 Construction Schedule

Construction Activity	Date of Completion
Project Start	Summer 2026
Install Erosion and Sediment Control BMPs	Summer 2026
Notify Utility Providers for Shut-Off	Summer 2026
Mass Grading	Summer 2026
Trenching & Utility Installation	Summer 2026
Foundation	Summer/Fall 2026
Structural	Fall/Winter 2026
Exterior	Winter/Spring 2026-2027
Interior (Utilities & HVAC)	Spring/Summer 2027
Interior (Finishing)	Summer/Fall 2027
Occupancy	Winter 2027

7. REPORTING AND RECORD KEEPING

7.1 Record Keeping

7.1.1 Site Logbook

A site logbook will be maintained for all on-site construction activities and will include:

- A record of the implementation of the SWPPP
- Site Inspections
- Sample Logs

7.1.2 Records Retention

Records will be retained during the life of the project and for a minimum of 3 years following completion of the project.

Permit documentation to be retained on-site:

- SWPPP
- Site Logbook

A copy of the SWPPP or access to the SWPPP will be provided to the public when requested in writing.

7.1.3 Updating the SWPPP

The SWPPP will be modified if:

- Found ineffective in eliminating or significantly minimizing pollutants in stormwater discharges from the site.
- There is a change in design, construction, operation, or maintenance at the construction site that has, or could have, a significant effect on the discharge of pollutants to waters of the State.

The SWPPP will be modified within 7 days if inspections or investigations determine additional or modified BMPs are necessary for compliance. An updated timeline for BMP implementation will be prepared.

8. SITE PLAN

Refer to the Civil Plans and the Contractor's TESC plans submitted for this project for site location, project boundary, stormwater discharge, and erosion control plan.

Appendix A

Erosion & Sediment Control BMPs

BMP C101: Preserving Natural Vegetation

Purpose

The purpose of preserving natural (or existing) vegetation is to reduce erosion wherever practicable. Limiting site disturbance is the single most effective method for reducing erosion. For example, conifers can hold up to about 50% of all rain that falls during a storm. Up to 20% to 30% of this rain may never reach the ground but is taken up by the tree or evaporates. Another benefit is that the rain held in the tree can be released slowly to the ground after the storm.

Conditions of Use

Natural vegetation should be preserved on steep slopes, near perennial and intermittent watercourses or swales, and on building sites in wooded areas.

- As required by the local jurisdiction.
- Phase construction to preserve natural vegetation on the project site for as long as possible during the construction period.

Design and Installation Specifications

Natural vegetation can be preserved in natural clumps or as individual trees, shrubs and vines.

The preservation of individual plants is more difficult because heavy equipment is generally used to remove unwanted vegetation. The points to remember when attempting to save individual plants are:

- Is the plant worth saving? Consider the location, species, size, age, vigor, and the work involved. Local jurisdictions may also have ordinances to save natural vegetation and trees.
- Fence or clearly mark areas around trees that are to be saved. It is preferable to keep ground disturbance away from the trees at least as far out as the dripline.

Plants need protection from three kinds of injuries:

- *Construction Equipment* - This injury can be above or below the ground level. Damage results from scarring, cutting of roots, and compaction of the soil. Placing a fenced buffer zone around plants to be saved prior to construction can prevent construction equipment injuries.
- *Grade Changes* - Changing the natural ground level will alter grades, which affects the plant's ability to obtain the necessary air, water, and minerals. Minor fills usually do not cause problems although sensitivity

between species does vary and should be checked. Trees can typically tolerate fill of 6 inches or less. For shrubs and other plants, the fill should be less.

When there are major changes in grade, it may become necessary to supply air to the roots of plants. This can be done by placing a layer of gravel and a tile system over the roots before the fill is made. The tile system should be laid out on the original grade leading from a drywell around the tree trunk. The system should then be covered with small stones to allow air to circulate over the root area.

Lowering the natural ground level can seriously damage trees and shrubs. The highest percentage of the plant roots are in the upper 12 inches of the soil and cuts of only 2 to 3 inches can cause serious injury. To protect the roots it may be necessary to terrace the immediate area around the plants to be saved. If roots are exposed, construction of retaining walls may be needed to keep the soil in place. Plants can also be preserved by leaving them on an undisturbed, gently sloping mound. To increase the chances for survival, it is best to limit grade changes and other soil disturbances to areas outside the dripline of the plant.

- *Excavations* - Protect trees and other plants when excavating for drainfields and power, water, and/or sewer lines. Where possible, the trenches should be routed around trees and large shrubs. When this is not possible, it is best to tunnel under them. This can be done with hand tools or with power augers. If it is not possible to route the trench around plants to be saved, then the following should be observed:
 - Cut as few roots as possible. When you have to cut, cut clean. Paint cut root ends with a wood dressing like asphalt base paint if roots will be exposed for more than 24 hours.
 - Backfill the trench as soon as possible.
 - Tunnel beneath root systems as close to the center of the main trunk to preserve most of the important feeder roots.

Some problems that can be encountered are:

- Maple, Dogwood, Red alder, Western hemlock, Western red cedar, and Douglas fir do not readily adjust to changes in environment and special care should be taken to protect these trees.
- The windthrow hazard of Pacific silver fir and madrona is high, while that of Western hemlock is moderate. The danger of windthrow increases where dense stands have been thinned. Other species (unless they are on shallow, wet soils less than 20 inches deep) have a low windthrow hazard.
- Cottonwoods, maples, and willows have water-seeking roots. These can cause trouble in sewer lines and infiltration fields. On the other hand, they thrive in high moisture conditions that other trees would not.
- Thinning operations in pure or mixed stands of grand fir, Pacific silver fir, noble fir, Sitka spruce, western red cedar, western hemlock, Pacific dogwood, and red alder can cause serious disease problems. Disease can become established through damaged limbs, trunks, roots, and freshly cut stumps. Diseased and weakened trees are also susceptible to insect attack.

Maintenance Standards

Inspect flagged and/or fenced areas regularly to make sure flagging or fencing has not been removed or damaged. If the flagging or fencing has been damaged or visibility reduced, it shall be repaired or replaced

immediately and visibility restored.

If tree roots have been exposed or injured, “prune” cleanly with an appropriate pruning saw or loppers directly above the damaged roots and recover with native soils. Treatment of sap flowing trees (e.g. fir, hemlock, pine, soft maples) is not advised as sap forms a natural healing barrier.

Washington State Department of Ecology

2024 Stormwater Management Manual for Western Washington (2024 SWMMWW)

Publication No. 24-10-013

BMP C102: Buffer Zones

Purpose

Creation of an undisturbed area or strip of natural vegetation or an established suitable planting that will provide a living filter to reduce soil erosion and stormwater runoff velocities.

Conditions of Use

Buffer zones are used along streams, wetlands and other bodies of water that need protection from erosion and sedimentation. Contractors can use vegetative buffer zone BMPs to protect natural swales and they can incorporate them into the natural landscaping of an area.

Do not use critical area buffer zones as sediment treatment areas. These areas shall remain completely undisturbed. The local permitting authority may expand the buffer widths temporarily to allow the use of the expanded area for removal of sediment.

The types of buffer zones can change the level of protection required as shown below:

- Designated Critical Area Buffers - buffers that protect Critical Areas, as defined by the Washington State Growth Management Act, and are established and managed by the local permitting authority. These should not be disturbed and must be protected with sediment control BMPs to prevent impacts. The local permitting authority may expand the buffer widths temporarily to allow the use of the expanded area for removal of sediment.
- Vegetative Buffer Zones - areas that may be identified in undisturbed vegetation areas or managed vegetation areas that are outside any Designated Critical Area Buffer. They may be utilized to provide an additional sediment control area and/or reduce runoff velocities. If being used for preservation of natural vegetation, they should be arranged in clumps or strips. They can be used to protect natural swales and incorporated into the natural landscaping area.

Design and Installation Specifications

- Preserving natural vegetation or plantings in clumps, blocks, or strips is generally the easiest and most successful method.
- Leave all unstable steep slopes in natural vegetation.
- Mark clearing limits and keep all equipment and construction debris out of the natural areas and buffer zones. Steel construction fencing is the most effective method to protect sensitive areas and buffers.

Alternatively, wire-backed silt fence on steel posts is marginally effective. Flagging alone is typically not effective.

- Keep all excavations outside the dripline of trees and shrubs.
- Do not push debris or extra soil into the buffer zone area because it will cause damage by burying and smothering vegetation.
- Vegetative buffer zones for streams, lakes or other waterways shall be established by the local permitting authority or other state or federal permits or approvals.

Maintenance Standards

Inspect the area frequently to make sure flagging remains in place and the area remains undisturbed. Replace all damaged flagging immediately. Remove all materials located in the buffer area that may impede the ability of the vegetation to act as a filter.

Washington State Department of Ecology

2024 Stormwater Management Manual for Western Washington (2024 SWMMWW)

Publication No. 24-10-013

BMP C103: High-Visibility Fence

Purpose

High-visibility fencing is intended to:

- Restrict clearing to approved limits.
- Prevent disturbance of sensitive areas, their buffers, and other areas required to be left undisturbed.
- Limit construction traffic to designated construction entrances, exits, or internal roads.
- Protect areas where marking with survey tape may not provide adequate protection.

Conditions of Use

To establish clearing limits, plastic, fabric, or metal fence may be used:

- At the boundary of sensitive areas, their buffers, and other areas required to be left uncleared.
- As necessary to control vehicle access to and on the site.

Design and Installation Specifications

High-visibility plastic fence shall be composed of a high-density polyethylene (HDPE) material and shall be at least four feet in height. Posts for the fencing shall be steel or wood and placed every 6 feet on center (maximum) or as needed to ensure rigidity. The fencing shall be fastened to the post every six inches with a polyethylene tie. On long continuous lengths of fencing, a tension wire or rope shall be used as a top stringer to prevent sagging between posts. The fence color shall be high-visibility orange. The fence tensile strength shall be 360 lbs/ft using the ASTM D4595 testing method.

If appropriate, install fabric silt fence in accordance with [BMP C233: Silt Fence](#) to act as high-visibility fence. Silt fence shall be at least 3 feet high and must be highly visible to meet the requirements of this BMP.

Metal fences shall be designed and installed according to the manufacturer's specifications.

Metal fences shall be at least 3 feet high and must be highly visible.

Fences shall not be wired or stapled to trees.

Maintenance Standards

If the fence has been damaged or visibility reduced, it shall be repaired or replaced immediately and visibility restored.

Washington State Department of Ecology

2024 Stormwater Management Manual for Western Washington (2024 SWMMWW)

Publication No. 24-10-013

BMP C105: Stabilized Construction Access

Purpose

Stabilized construction accesses are established to reduce the amount of sediment transported onto paved roads outside the project site by vehicles or equipment. This is done by constructing a stabilized pad of quarry spalls at entrances and exits for project sites.

Conditions of Use

Construction accesses shall be stabilized wherever traffic will be entering or leaving a construction site if paved roads or other paved areas are within 1,000 feet of the site.

For residential subdivision construction sites, provide a stabilized construction access for each residence, rather than only at the main subdivision entrance. Stabilized surfaces shall be of sufficient length/width to provide vehicle access/parking, based on lot size and configuration.

On large commercial, highway, and road projects, the designer should include enough extra materials in the contract to allow for additional stabilized accesses not shown in the initial Construction SWPPP. It is difficult to determine exactly where access to these projects will take place; additional materials will enable the contractor to install them where needed.

Design and Installation Specifications

- See [Figure II-4.1: Stabilized Construction Access](#) for details. Note: the 100' minimum length of the access shall be reduced to the maximum practicable size when the size or configuration of the site does not allow the full length (100').
- Construct stabilized construction accesses with a 12-inch thick pad of 4-inch to 8-inch quarry spalls, a 4-inch course of asphalt treated base (ATB), or use existing pavement. Do not use crushed concrete, cement, or calcium chloride for construction access stabilization because these products raise pH levels in stormwater and concrete discharge to waters of the State is prohibited.
- A separation geotextile shall be placed under the spalls to prevent fine sediment from pumping up into the rock pad. The geotextile shall meet the standards listed in [Table II-4.2: Stabilized Construction Access Geotextile Standards](#).

Table II-4.2: Stabilized Construction Access Geotextile Standards

Geotextile Property	Required Value
Grab Tensile Strength (ASTM D4751)	200 psi min.
Grab Tensile Elongation (ASTM D4632)	30% max.
Mullen Burst Strength (ASTM D3786-80a)	400 psi min.
AOS (ASTM D4751)	No. 20 to No. 45 (U.S. standard sieve size)

- Consider early installation of the first lift of asphalt in areas that will be paved; this can be used as a stabilized access. Also consider the installation of excess concrete as a stabilized access. During large concrete pours, excess concrete is often available for this purpose.
- Fencing (see [BMP C103: High-Visibility Fence](#)) shall be installed as necessary to restrict traffic to the construction access.
- Whenever possible, the access shall be constructed on a firm, compacted subgrade. This can substantially increase the effectiveness of the pad and reduce the need for maintenance.
- Construction accesses should avoid crossing existing sidewalks and back of walk drains if at all possible. If a construction access must cross a sidewalk or back of walk drain, the full length of the sidewalk and back of walk drain must be covered and protected from sediment leaving the site.

Alternative Material Specification

WSDOT has raised safety concerns about the quarry spall rock specified above. WSDOT observes that the 4-inch to 8-inch rock sizes can become trapped between dually truck tires, and then released off-site at highway speeds. WSDOT has chosen to use a modified specification for the rock while continuously verifying that the stabilized construction access remains effective. To remain effective, the BMP must prevent sediment from migrating off site. To date, there has been no performance testing to verify operation of this new specification. Local jurisdictions may use the alternative specification, but must perform increased off-site inspection if they use, or allow others to use, it.

Stabilized construction accesses may use material that meets the requirements of WSDOT's *Standard Specifications for Road, Bridge, and Municipal Construction* Section 9-03.9(1) ([WSDOT, 2016](#)) for ballast except for the following special requirements.

The grading and quality requirements are listed in [Table II-4.3: Stabilized Construction Access Alternative Material Requirements](#).

Table II-4.3: Stabilized Construction Access Alternative Material Requirements

Sieve Size	Percent Passing
2½"	99 to 100
2"	65 to 100

Sieve Size	Percent Passing
¾"	40 to 80
No. 4	5 max.
No. 100	0 to 2
% Fracture	75 min.
<p>Notes:</p> <ol style="list-style-type: none"> 1. All percentages are by weight. 2. The sand equivalent value and dust ratio requirements do not apply. 3. The fracture requirement shall be at least one fractured face and will apply the combined aggregate retained on the No. 4 sieve in accordance with FOP for AASHTO T 335. 	

Maintenance Standards

Quarry spalls shall be added if the pad is no longer in accordance with the specifications.

- If the access is not preventing sediment from being tracked onto pavement, then alternative measures to keep the streets free of sediment shall be used. This may include replacement/cleaning of the existing quarry spalls, street sweeping, an increase in the dimensions of the access, or the installation of [BMP C106: Wheel Wash](#).
- Any sediment that is tracked onto pavement shall be removed by shoveling or street sweeping. The sediment collected by sweeping shall be removed or stabilized on site. The pavement shall not be cleaned by washing down the street, except when sweeping is ineffective and there is a threat to public safety. If it is necessary to wash the streets, the construction of a small sump to contain the wash water shall be considered. The sediment would then be washed into the sump where it can be controlled.
- Perform street sweeping by hand or with a high efficiency sweeper. Do not use a non-high efficiency mechanical sweeper because this creates dust and throws soils into storm systems or conveyance ditches.
- Any quarry spalls that are loosened from the pad, which end up on the roadway shall be removed immediately.
- If vehicles are entering or exiting the site at points other than the construction access(es), [BMP C103: High-Visibility Fence](#) shall be installed to control traffic.
- Upon project completion and site stabilization, all construction accesses intended as permanent access for maintenance shall be permanently stabilized.

Figure II-4.1: Stabilized Construction Access

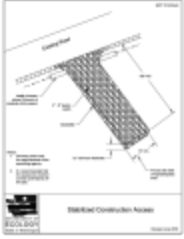

[Download PDF](#)

Approved as Functionally Equivalent

Ecology has approved products as able to meet the requirements of this BMP. The products did not pass through the Technology Assessment Protocol – Ecology (TAPE) process. Local jurisdictions may choose not to accept these products, or may require additional testing prior to consideration for local use. Products that Ecology has approved as functionally equivalent are available for review on Ecology’s website at:

<https://ecology.wa.gov/Regulations-Permits/Guidance-technical-assistance/Stormwater-permittee-guidance-resources/Emerging-stormwater-treatment-technologies>

Washington State Department of Ecology

2024 Stormwater Management Manual for Western Washington (2024 SWMMWW)

Publication No. 24-10-013

BMP C106: Wheel Wash

Purpose

Wheel washes reduce the amount of sediment transported onto paved roads by washing dirt from the wheels of motor vehicles prior to the motor vehicles leaving the construction site.

Conditions of Use

- Use a wheel wash when [BMP C105: Stabilized Construction Access](#) is not preventing sediment from being tracked off site.
- Wheel washing is generally an effective BMP when installed with careful attention to topography. For example, a wheel wash can be detrimental if installed at the top of a slope abutting a right-of-way where the water from the dripping truck can run unimpeded into the street.
- Pressure washing combined with an adequately sized and surfaced pad with direct drainage to a large 10-foot x 10-foot sump can be very effective.
- Wheel wash wastewater is not stormwater. It is commonly called process water, and must be discharged to a separate on-site treatment system that prevents discharge to waters of the State, or to the sanitary sewer with local sewer district approval.
- Wheel washes may use closed-loop recirculation systems to conserve water use.
- Wheel wash wastewater shall not include wastewater from concrete washout areas.
- When practical, the wheel wash should be placed in sequence with [BMP C105: Stabilized Construction Access](#). Locate the wheel wash such that vehicles exiting the wheel wash will enter directly onto [BMP C105: Stabilized Construction Access](#). In order to achieve this, [BMP C105: Stabilized Construction Access](#) may need to be extended beyond the standard installation to meet the exit of the wheel wash.

Design and Installation Specifications

Suggested details are shown in [Figure II-4.2: Wheel Wash](#). The local permitting authority may allow other designs. A minimum of 6 inches of asphalt treated base (ATB) over crushed base material or 8 inches over a good subgrade is recommended to pave the wheel wash.

Use a low clearance truck to test the wheel wash before paving. Either a belly dump or lowboy will work well to test clearance.

Keep the water level from 12 to 14 inches deep to avoid damage to truck hubs and filling the truck tongues with water.

Midpoint spray nozzles are only needed in extremely muddy conditions.

Wheel wash systems should be designed with a small grade change, 6- to 12-inches for a 10-foot-wide pond, to allow sediment to flow to the low side of pond to help prevent re-suspension of sediment. A drainpipe with a 2- to 3-foot riser should be installed on the low side of the pond to allow for easy cleaning and refilling. Polymers may be used to promote coagulation and flocculation in a closed-loop system. Polyacrylamide (PAM) added to the wheel wash water at a rate of 0.25 to 0.5 pounds per 1,000 gallons of water increases effectiveness and reduces cleanup time. If PAM is already being used for dust or erosion control and is being applied by a water truck, the same truck can be used to change the wash water. PAM use shall be reviewed and approved by the local permitting authority. Discharge of PAM may be a basis for penalties per [RCW 90.48.080](#).

Maintenance Standards

The wheel wash should start out each day with fresh water.

The wheel wash water should be changed a minimum of once per day. On large earthwork jobs where more than 10 to 20 trucks per hour are expected, the wheel wash water will need to be changed more often.

Approved as Functionally Equivalent

Ecology has approved products as able to meet the requirements of this BMP. The products did not pass through the Technology Assessment Protocol – Ecology (TAPE) process. Local jurisdictions may choose not to accept these products, or may require additional testing prior to consideration for local use. Products that Ecology has approved as functionally equivalent are available for review on Ecology's website at:

<https://ecology.wa.gov/Regulations-Permits/Guidance-technical-assistance/Stormwater-permittee-guidance-resources/Emerging-stormwater-treatment-technologies>

Figure II-4.2: Wheel Wash

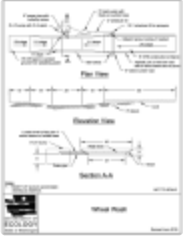

[Download PDF](#)

Washington State Department of Ecology

2024 Stormwater Management Manual for Western Washington (2024 SWMMWW)

Publication No. 24-10-013

BMP C120: Temporary and Permanent Seeding

Purpose

Seeding reduces erosion by stabilizing exposed soils. A well-established vegetative cover is one of the most effective methods of reducing erosion.

Conditions of Use

- Use seeding throughout the project on disturbed areas that have reached final grade or that will remain unworked for more than 30 days. See [II-2.5 Element 5: Stabilize Soils](#) for specific timelines for stabilizing exposed soils.
- See [Table II-4.4: Seeding Windows in Western Washington](#) for appropriate seeding windows.
- Review all disturbed areas in late August to early September and complete all seeding by the end of September. Otherwise, vegetation will not establish itself enough to provide more than average protection.
- Mulch is required at all times for seeding because it protects seeds from heat, moisture loss, and transport due to runoff. Mulch can be applied on top of the seed or simultaneously by hydroseeding. See [BMP C121: Mulching](#) for specifications.
- Seed and mulch all disturbed areas not otherwise vegetated at final site stabilization. Final stabilization means the completion of all soil disturbing activities at the site and the establishment of a permanent vegetative cover, or equivalent permanent stabilization measures (such as pavement, riprap, gabions, or geotextiles) which will prevent erosion. See [BMP T5.13: Post-Construction Soil Quality and Depth](#).

Table II-4.4: Seeding Windows in Western Washington

Month	Seeding Recommendations
January	Seeding requires a cover of mulch or an erosion control blanket until 75% grass cover is established
February	
March	
April	Optimum seeding window
May	
June	

Month	Seeding Recommendations
July	Seeding requires irrigation until 75% grass cover is established
August	
September	Optimum seeding window
October	Seeding requires a cover of mulch or an erosion control blanket until 75 percent grass cover is established
November	
December	

Design and Installation Specifications

General

- Install channels intended for vegetation before starting major earthwork and hydroseed with a Bonded Fiber Matrix (BFM). For vegetated channels that will have high flows, install erosion control blankets over the top of hydroseed. Before allowing water to flow in vegetated channels, establish a 75% vegetation cover. If vegetated channels cannot be established by seed before water flow, install sod or prevegetated mats in the channel bottom over top of hydromulch and erosion control blankets.
- Confirm the installation of all required stormwater control measures to prevent seed from washing away.
- Hydroseed applications shall include a minimum of 1,500 pounds per acre (lb/acre) of mulch with 3% tackifier. See [BMP C121: Mulching](#) for specifications.
- Areas that will have seeding only, and not landscaping, may need compost or meal-based mulch included in the hydroseed in order to establish vegetation. Re-install native topsoil on the disturbed soil surface before application. See [BMP T5.13: Post-Construction Soil Quality and Depth](#).
- When installing seed via hydroseeding operations, only about 1/3 of the seed actually ends up in contact with the soil surface. This reduces the ability to establish a good stand of grass quickly. To overcome this, consider increasing seed quantities by up to 50 percent.
- Vegetation establishment can be enhanced by one of the following two approaches:
 - Approach 1: Enhance vegetation establishment by dividing the hydromulch operation into two phases:
 - Phase 1 – Install all seed and fertilizer with 25% to 30% mulch and tackifier onto the soil in the first lift.
 - Phase 2 – Install the remaining mulch and tackifier over the first lift.
 - Approach 2: Vegetation can also be enhanced by:

- Installing the mulch, seed, fertilizer, and tackifier in one lift;
- Spreading or blowing straw over the top of the hydromulch at a rate of about 800 to 1,000 lb/acre; or
- Holding straw in place with a standard tackifier.

Both of these approaches (Approach 1 and Approach 2) will increase cost moderately but will greatly improve and enhance vegetative establishment. The increased cost may be offset by the reduced need for:

- Irrigation,
- Reapplication of mulch, and
- Repair of failed slope surfaces.

Either of these approaches can use standard hydromulch (1,500 lb/acre minimum) and BFM/mechanically bonded fiber matrix (MBFM) (3,000 lb/acre minimum).

- Seed may be installed by hand if it is:
 - Temporary and covered by straw, mulch, or topsoil; or
 - Permanent in small areas (usually less than 1 acre) and covered with mulch, topsoil, or erosion blankets.
- Consult the local suppliers and/or the local conservation district for their recommendations for appropriate seed mixes and application rates. The appropriate mix depends on a variety of factors, including location, exposure, soil type, slope, and expected foot traffic.
- In addition to meeting erosion control functions and not hindering maintenance operations, selection of long-lived, successional growth native vegetation that can compete against or exclude weeds and grow with minimal maintenance after plant establishment is preferred. Provide diversity to the greatest extent possible and plan for a succession of flowering times to improve pollinator habitat.
- The seed mixes listed in [Table II-4.5: Temporary and Permanent Seed Mixes for Western Washington](#) include recommended mixes for both temporary and permanent seeding. Alternative seed mixes approved by the local jurisdiction may also be used.
- Apply the mixes in [Table II-4.5: Temporary and Permanent Seed Mixes for Western Washington](#), with the exception of the wet area seed mix, at a rate of 120 pounds per acre. This rate can be reduced if soil amendments or slow-release fertilizers are used. Apply the wet area seed mix at a rate of 60 pounds per acre.

Table II-4.5: Temporary and Permanent Seed Mixes for Western Washington

Common Name	Latin Name	% Weight	% Purity	% Germination
<p>Temporary Erosion Control Seed Mix</p> <p>A standard mix for areas requiring a temporary vegetative cover.</p>				

Common Name	Latin Name	% Weight	% Purity	% Germination
Chewings or annual blue grass	<i>Festuca rubra var. commutata</i> or <i>Poa anna</i>	40	98	90
Perennial rye	<i>Lolium perenne</i>	50	98	90
Redtop or colonial bentgrass	<i>Agrostis alba</i> or <i>Agrostis tenuis</i>	5	92	85
White dutch clover	<i>Trifolium repens</i>	5	98	90
Landscaping Seed Mix A recommended mix for landscaping seed.				
Perennial rye blend	<i>Lolium perenne</i>	70	98	90
Chewings and red fescue blend	<i>Festuca rubra var. commutata</i> or <i>Festuca rubra</i>	30	98	90
Low-Growing Turf Seed Mix A turf seed mix for dry situations where there is no need for watering. This mix requires very little maintenance.				
Dwarf tall fescue (several varieties)	<i>Festuca arundinacea var.</i>	45	98	90
Dwarf perennial rye (Barclay)	<i>Lolium perenne var. barclay</i>	30	98	90
Red fescue	<i>Festuca rubra</i>	20	98	90
Colonial bentgrass	<i>Agrostis tenuis</i>	5	98	90
Bioswale Seed Mix A seed mix for bioswales and other intermittently wet areas.				
Tall or meadow fescue	<i>Festuca arundinacea</i> or <i>Festuca elatior</i>	75-80	98	90
Seaside/Creeping bentgrass	<i>Agrostis palustris</i>	10-15	92	85
Redtop bentgrass	<i>Agrostis alba</i> or <i>Agrostis gigantea</i>	5-10	90	80
Wet Area Seed Mix A low-growing, relatively non-invasive seed mix appropriate for very wet areas that are not regulated wetlands. Consult Hydraulic Permit Authority (HPA) for seed mixes if applicable.				
Tall or meadow fescue	<i>Festuca arundinacea</i> or <i>Festuca elatior</i>	60-70	98	90
Seaside/Creeping bentgrass	<i>Agrostis palustris</i>	10-15	98	85
Meadow foxtail	<i>Alepocurus pratensis</i>	10-15	90	80

Common Name	Latin Name	% Weight	% Purity	% Germination
Alsike clover	<i>Trifolium hybridum</i>	1-6	98	90
Redtop bentgrass	<i>Agrostis alba</i>	1-6	92	85
Meadow Seed Mix				
A recommended meadow seed mix for infrequently maintained areas or non-maintained areas where colonization by native plants is desirable. Likely applications include rural road and utility right-of-way. Seeding should take place in September or very early October in order to obtain adequate establishment prior to the winter months. Consider the appropriateness of clover, a fairly invasive species, in the mix. Amending the soil can reduce the need for clover.				
Redtop or Oregon bentgrass	<i>Agrostis alba</i> or <i>Agrostis oregonensis</i>	20	92	85
Red fescue	<i>Festuca rubra</i>	70	98	90
White dutch clover	<i>Trifolium repens</i>	10	98	90

Roughening and Rototilling

- The seedbed should be firm and rough. Roughen all soil no matter what the slope. Track walk slopes before seeding if engineering purposes require compaction. Backblading or smoothing of slopes greater than 4H:1V is not allowed if they are to be seeded.
- Restoration-based landscape practices require deeper incorporation than that provided by a simple, single-pass rototilling treatment. Wherever practical, initially rip the subgrade to improve long-term permeability, infiltration, and water inflow qualities. At a minimum, permanent areas shall receive soil amendments to achieve organic matter and permeability performance defined in engineered soil/landscape systems. For systems that are deeper than 8 inches, complete the rototilling process in multiple lifts, or prepare the soil amendments per the specifications and place to achieve the specified depth.

Fertilizers

- Conducting soil tests to determine the exact type and quantity of fertilizer needed is recommended. This will prevent the overapplication of fertilizer.
- Organic matter is the most appropriate form of fertilizer because it provides nutrients (including nitrogen, phosphorus, and potassium) in the least water-soluble form.
- In general, use 10-4-6 N-P-K (nitrogen-phosphorus-potassium) fertilizer at a rate of 90 pounds per acre.
- Always use slow-release fertilizers because they are more efficient and have fewer environmental impacts. Do not add fertilizer to the hydromulch machine, or agitate, more than 20 minutes before use. Too much agitation destroys the slow-release coating.
- There are numerous products available to take the place of chemical fertilizers, including several with seaweed extracts that are beneficial to soil microbes and organisms. If 100% cottonseed meal is used as

the mulch in hydroseed, chemical fertilizer may not be necessary. Cottonseed meal provides a good source of long-term, slow-release, available nitrogen.

Bonded Fiber Matrix and Mechanically Bonded Fiber Matrix

- On steep slopes, use Bonded Fiber Matrix (BFM) or Mechanically Bonded Fiber Matrix (MBFM) products. Apply BFM/MBFM products at a minimum rate of 3,000 pounds per acre with approximately 10% tackifier. Achieve a minimum of 95% soil coverage during application. Numerous products are available commercially. Most products require 24-36 hours to cure before rainfall, and cannot be installed on wet or saturated soils. Generally, products come in 40-50 pound bags and include all necessary ingredients except for seed and fertilizer.
- Install products per manufacturer's instructions.
- BFMs and MBFMs provide good alternatives to blankets in most areas requiring vegetation establishment. Advantages over blankets include the following:
 - BFM and MBFMs do not require surface preparation.
 - Helicopters can assist in installing BFM and MBFMs in remote areas.
 - On slopes steeper than 2.5H:1V, blanket installers may require ropes and harnesses for safety.
 - Installing BFM and MBFMs can save at least \$1,000 per acre compared to blankets.

Maintenance Standards

- Reseed any seeded areas that fail to establish at least 75% cover (100% cover for areas that receive sheet or concentrated flows) of all seeded areas after 3 months of active growth following germination during the growing season. If reseeding is ineffective, use an alternate method, such as sodding, mulching, or nets/blankets. If winter weather prevents adequate grass growth, this time limit may be relaxed at the discretion of the local authority when sensitive areas would otherwise be protected.
- Reseed and protect by mulch any areas that experience erosion after achieving adequate cover. If the erosion problem is drainage related, the problem shall be fixed and the eroded area reseeded and protected by mulch.
- Supply seeded areas with adequate moisture, but do not water to the extent that it causes runoff.

Approved as Functionally Equivalent

Ecology has approved products as able to meet the requirements of this BMP. The products did not pass through the Technology Assessment Protocol – Ecology (TAPE) process. Local jurisdictions may choose not to accept these products, or may require additional testing prior to consideration for local use. Products that Ecology has approved as functionally equivalent are available for review on Ecology's website at:

<https://ecology.wa.gov/Regulations-Permits/Guidance-technical-assistance/Stormwater-permittee-guidance-resources/Emerging-stormwater-treatment-technologies>

Washington State Department of Ecology

2024 Stormwater Management Manual for Western Washington (2024 SWMMWW)

Publication No. 24-10-013

BMP C121: Mulching

Purpose

Mulching soils provides immediate temporary protection from erosion. Mulch also enhances plant establishment by conserving moisture, holding fertilizer, seed, and topsoil in place, and moderating soil temperatures. There are a variety of mulches that can be used. This section discusses only the most common types of mulch.

Conditions of Use

As a temporary cover measure, mulch should be used:

- For less than 30 days on disturbed areas that require cover.
- At all times for seeded areas, especially during the wet season and during the hot summer months.
- During the wet season on slopes steeper than 3H:1V with more than 10 feet of vertical relief.

Mulch may be applied at any time of the year and must be refreshed periodically.

For seeded areas, mulch may be made up of 100 percent:

- Cottonseed meal;
- Fibers made of wood, recycled cellulose, hemp, or kenaf;
- Compost;
- Or blends of these.

Tackifier shall be plant-based, such as guar or alpha plantago, or chemical-based such as polyacrylamide or polymers.

Generally, mulches come in 40-50 pound bags. Seed and fertilizer are added at time of application.

Recycled cellulose may contain polychlorinated biphenyl (PCBs). Ecology recommends that products should be evaluated for PCBs prior to use.

Refer to [BMP C126: Polyacrylamide \(PAM\) for Soil Erosion Protection](#) for conditions of use. PAM shall not be directly applied to water or allowed to enter a water body.

Any mulch or tackifier product used shall be installed per the manufacturer's instructions.

Design and Installation Specifications

For mulch materials, application rates, and specifications, see [Table II-4.7: Mulch Standards and Guidelines](#). Consult with the local supplier or the local conservation district for their recommendations. Increase the application rate until the ground is 95% covered (i.e. not visible under the mulch layer). Note: Thickness may be increased for disturbed areas in or near sensitive areas or other areas highly susceptible to erosion.

Where the option of “Compost” is selected, it should be a coarse compost that meets the size gradations listed in [Table II-4.6: Size Gradations of Compost as Mulch Material](#) when tested in accordance with Test Method 02.02-B found in *Test Methods for the Examination of Composting and Compost* ([Thompson, 2001](#)).

Mulch used within the ordinary high-water mark of surface waters should be selected to minimize potential flotation of organic matter. Composted organic materials have higher specific gravities (densities) than straw, wood, or chipped material. Consult the Hydraulic Permit Authority (HPA) for mulch mixes if applicable.

Table II-4.6: Size Gradations of Compost as Mulch Material

Sieve Size	Percent Passing
3"	100%
1"	90% - 100%
3/4"	70% - 100%
1/4"	40% - 100%

Table II-4.7: Mulch Standards and Guidelines

Mulch Material	Guideline	Description
Straw	Quality Standards	Air-dried; free from undesirable seed and coarse material.
	Application Rates	2" to 3" thick; 5 bales per 1,000 sf or 2 to 3 tons per acre
	Remarks	Cost-effective protection when applied with adequate thickness. Hand-application generally requires greater thickness than blown straw. The thickness of straw may be reduced by half when used in conjunction with seeding. In windy areas, straw must be held in place by crimping, using a tackifier, or covering with netting. Blown straw always has to be held in place with a tackifier because even light winds will blow it away. Straw, however, has several deficiencies that should be considered when selecting mulch materials. It often introduces and/or encourages the propagation of weed species, and it has no significant long-term benefits. Straw should only be used if mulches with long-term benefits are unavailable locally. It should also not be used within the ordinary high-water elevation of surface waters (due to flotation).
Hydromulch	Quality Standards	No growth inhibiting factors.

Mulch Material	Guideline	Description
	Application Rates	Approx. 35-45 lbs per 1,000 sf or 1,500 - 2,000 lbs per acre
	Remarks	Shall be applied with hydromulcher. Shall not be used without seed and tackifier unless the application rate is at least doubled. Fibers longer than about 3/4 - 1 inch clog hydromulch equipment. Fibers should be kept to less than 3/4 inch.
Compost	Quality Standards	No visible water or dust during handling. Must be produced per WAC 173-350 , Solid Waste Handling Standards, but may have up to 35% biosolids.
	Application Rates	2" thick minimum; approximately 100 tons per acre (approximately 750 lbs per cubic yard)
	Remarks	More effective control can be obtained by increasing thickness to 3". Compost makes an excellent mulch for protecting final grades until landscaping because it can be directly seeded or tilled into soil as an amendment. Compost used for mulch has a coarser size gradation than compost used for BMP C125: Topsoiling / Composting or BMP T5.13: Post-Construction Soil Quality and Depth . It is more stable and practical to use in wet areas and during rainy weather conditions. Do not use compost near wetlands if biosolids are included. Do not use compost near phosphorous impaired water bodies.
Chipped Site Vegetation	Quality Standards	Gradations from fines to 6 inches in length for texture, variation, and interlocking properties. Include a mix of various sizes so that the average size is between 2 and 4 inches.
	Application Rates	2" thick minimum.
	Remarks	<p>This is a cost-effective way to dispose of debris from clearing and grubbing, and it eliminates the problems associated with burning. Generally, it should not be used on slopes above approximately 10% because of its tendency to be transported by runoff. It is not recommended within 200 feet of surface waters. If permanent seeding or planting is expected shortly after mulch, the decomposition of the chipped vegetation may tie up nutrients important to grass establishment.</p> <p>Note: Thick application of this material over existing grass, herbaceous species, and some groundcovers could smother and kill vegetation.</p>
Wood-Based Mulch	Quality Standards	No visible water or dust during handling. Must be purchased from a supplier with a Solid Waste Handling Permit or one exempt from solid waste regulations.
	Application Rates	2" thick minimum; approximately 100 tons per acre (approximately 750 lbs. per cubic yard).
	Remarks	This material is often called "wood straw" or "hog fuel". The use of mulch ultimately improves the organic matter in the soil. Special caution is advised regarding the source and composition of wood-based mulches. Its preparation typically does not provide any weed seed control, so evidence of residual vegetation in its composition or known inclusion of weed plants or seeds should be monitored and prevented (or minimized).
Wood Strand Mulch	Quality Standards	A blend of loose, long, thin wood pieces derived from native conifer or deciduous trees with high length-to-width ratio.

Mulch Material	Guideline	Description
	Application Rates	2" thick minimum.
	Remarks	Cost-effective protection when applied with adequate thickness. A minimum of 95% of the wood strand shall have lengths between 2 and 10 inches, with a width and thickness between 1/16 and 0.5 inches. The mulch shall not contain resin, tannin, or other compounds in quantities that would be detrimental to plant life. Sawdust or wood shavings shall not be used as mulch. See specification 9-14.4(4) from the <i>Standard Specifications for Road, Bridge, and Municipal Construction</i> (WSDOT, 2016).

Maintenance Standards

The thickness of the mulch cover must be maintained.

Any areas that experience erosion shall be remulched and/or protected with a net or blanket. If the erosion problem is drainage related, then the problem shall be fixed and the eroded area remulched.

Washington State Department of Ecology

2024 Stormwater Management Manual for Western Washington (2024 SWMMWW)

Publication No. 24-10-013

BMP C123: Plastic Covering

Purpose

Plastic covering provides immediate, short-term erosion protection to slopes and disturbed areas.

Conditions of Use

Plastic covering may be used on disturbed areas that require cover measures for less than 30 days, except as stated below.

- Plastic is particularly useful for protecting cut and fill slopes and stockpiles. However, the relatively rapid breakdown of most polyethylene sheeting makes it unsuitable for applications greater than six months.
- Due to rapid runoff caused by plastic covering, do not use this method upslope of areas that might be adversely impacted by concentrated runoff. Such areas include steep and/or unstable slopes.
- Plastic sheeting may result in increased runoff volumes and velocities, requiring additional on-site measures to counteract the increases. Creating a trough with wattles or other material can convey clean water away from these areas.
- To prevent undercutting, trench and backfill rolled plastic covering products.
- Although the plastic material is inexpensive to purchase, the cost of installation, maintenance, removal, and disposal add to the total costs of this BMP.
- Whenever plastic is used to protect slopes, install water collection measures at the base of the slope. These measures include plastic-covered berms, channels, and pipes used to convey clean rainwater away from bare soil and disturbed areas. Do not mix clean runoff from a plastic covered slope with dirty runoff from a project.
- Other uses for plastic include:
 - Temporary ditch liner.
 - Pond liner in temporary sediment pond.
 - Liner for bermed temporary fuel storage area if plastic is not reactive to the type of fuel being stored.
 - Emergency slope protection during heavy rains.
 - Temporary drainpipe (“elephant trunk”) used to direct water.

Design and Installation Specifications

- Plastic slope cover must be installed as follows:
 1. Run plastic up and down the slope, not across the slope.
 2. Plastic may be installed perpendicular to a slope if the slope length is less than 10 feet.
 3. Provide a minimum of 8-inch overlap at the seams.
 4. On long or wide slopes, or slopes subject to wind, tape all seams.
 5. Place plastic into a small (12-inch wide by 6-inch deep) slot trench at the top of the slope and backfill with soil to keep water from flowing underneath.
 6. Place sand filled burlap or geotextile bags every 3 to 6 feet along seams and tie them together with twine to hold them in place.
 7. Inspect plastic for rips, tears, and open seams regularly and repair immediately. This prevents high velocity runoff from contacting bare soil, which causes extreme erosion.
 8. Sandbags may be lowered into place tied to ropes. However, all sandbags must be staked in place.
- Plastic sheeting shall have a minimum thickness of 6 mil.
- If erosion at the toe of a slope is likely, a gravel berm, riprap, or other suitable protection shall be installed at the toe of the slope in order to reduce the velocity of runoff.

Maintenance Standards

- Torn sheets must be replaced and open seams repaired.
- Completely remove and replace the plastic if it begins to deteriorate due to ultraviolet radiation.
- Completely remove plastic when no longer needed.
- Dispose of old tires used to weight down plastic sheeting appropriately.

Approved as Functionally Equivalent

Ecology has approved products as able to meet the requirements of this BMP. The products did not pass through the Technology Assessment Protocol – Ecology (TAPE) process. Local jurisdictions may choose not to accept these products, or may require additional testing prior to consideration for local use. Products that Ecology has approved as functionally equivalent are available for review on Ecology’s website at:

<https://ecology.wa.gov/Regulations-Permits/Guidance-technical-assistance/Stormwater-permittee-guidance-resources/Emerging-stormwater-treatment-technologies>

Washington State Department of Ecology

2024 Stormwater Management Manual for Western Washington (2024 SWMMWW)

Publication No. 24-10-013

BMP C124: Sodding

Purpose

The purpose of sodding is to establish turf for immediate erosion protection and to stabilize drainage paths where concentrated overland flow will occur.

Conditions of Use

Sodding may be used in the following areas:

- Disturbed areas that require short-term or long-term cover.
- Disturbed areas that require immediate vegetative cover.
- All waterways that require vegetative lining. Waterways may also be seeded rather than sodded, and protected with a net or blanket.

Design and Installation Specifications

Sod shall be free of weeds, have a uniform thickness (approximately 1-inch thick), and have a dense root mat for mechanical strength.

The following steps are recommended for sod installation:

1. Shape and smooth the surface to final grade in accordance with the approved grading plan. Consider any areas (such as swales) that need to be overexcavated below design elevation to allow room for placing soil amendment and sod.
2. Amend 4 inches (minimum) of compost into the top 8 inches of the soil if the organic content of the soil is less than ten percent or the permeability is less than 0.6 inches per hour. See Ecology's Compost web page for further information:

<https://ecology.wa.gov/Waste-Toxics/Reducing-recycling-waste/Organic-materials/Managing-organics-compost>

3. Fertilize according to the sod supplier's recommendations.
4. Work lime and fertilizer 1 to 2 inches into the soil, and smooth the surface.

5. Lay strips of sod beginning at the lowest area to be sodded and perpendicular to the direction of water flow. Wedge strips securely into place. Square the ends of each strip to provide for a close, tight fit. Stagger joints at least 12 inches. Staple on slopes steeper than 3H:1V. Staple the upstream edge of each sod strip.
6. Roll the sodded area and irrigate.
7. When sodding is carried out in alternating strips or other patterns, seed the areas between the sod immediately after sodding.

Maintenance Standards

If the grass is unhealthy, the cause shall be determined and appropriate action taken to reestablish a healthy ground cover. If it is impossible to establish a healthy ground cover due to frequent saturation, instability, or some other cause, the sod shall be removed, the area seeded with an appropriate mix, and protected with a net or blanket ([BMP C122: Nets and Blankets](#)).

Washington State Department of Ecology

2024 Stormwater Management Manual for Western Washington (2024 SWMMWW)

Publication No. 24-10-013

BMP C125: Topsoiling / Composting

Purpose

Topsoiling and composting provide a suitable growth medium for final site stabilization with vegetation. While not a permanent cover practice in itself, topsoiling and composting are an integral component of providing permanent cover in those areas where there is an unsuitable soil surface for plant growth. Use this BMP in conjunction with other BMPs such as [BMP C120: Temporary and Permanent Seeding](#), [BMP C121: Mulching](#), or [BMP C124: Sodding](#).

Implementation of this BMP may meet the post-construction requirements of [BMP T5.13: Post-Construction Soil Quality and Depth](#).

Native soils and disturbed soils that have been organically amended not only retain much more stormwater, but also serve as effective biofilters for urban pollutants and, by supporting more vigorous plant growth, reduce the water, fertilizer, and/or pesticides needed to support installed landscapes. Topsoil does not include any subsoils but only the material from the top several inches including organic debris.

Conditions of Use

- Permanent landscaped areas shall contain healthy topsoil that reduces the need for fertilizers, improves overall topsoil quality, provides for better vegetative health and vitality, improves hydrologic characteristics, and reduces the need for irrigation.
- Leave native soils and the duff layer undisturbed to the maximum extent practicable. Stripping of existing, properly functioning soil system and vegetation for the purpose of topsoiling during construction is not acceptable. Preserve existing soil systems in undisturbed and uncompacted conditions if functioning properly.
- Areas that already have good topsoil, such as undisturbed areas, do not require soil amendments.
- Restore, to the maximum extent practical, native soils disturbed during clearing and grading to a condition equal to or better than the original site condition's moisture-holding capacity. Use on-site native topsoil, incorporate amendments into on-site soil, or import blended topsoil to meet this requirement.
- Topsoiling is a required procedure when establishing vegetation on shallow soils, and soils of critically low pH (high acid) levels.
- Beware of where the topsoil comes from, and what vegetation was on site before disturbance. Invasive plant seeds may be included and could cause problems for establishing native plants, landscaped areas, or

grasses.

- Topsoil from the site will contain mycorrhizal bacteria that are necessary for healthy root growth and nutrient transfer. These native mycorrhizae are acclimated to the site and will provide optimum conditions for establishing grasses. Use commercially available mycorrhizae products when using off-site topsoil.

Design and Installation Specifications

Meet the following requirements for disturbed areas where topsoil will be applied (e.g. for disturbed areas that will be developed as lawn or other landscape):

- Maximize the depth of the topsoil wherever possible to provide the maximum possible infiltration capacity and beneficial growth medium. Topsoil shall have:
 - A minimum depth of 8 inches. Scarify subsoils below the topsoil layer at least 4 inches with some incorporation of the upper material to avoid stratified layers, where feasible. Ripping or re-structuring the subgrade may also provide additional benefits regarding the overall infiltration and interflow dynamics of the soil system. The decision to either layer topsoil over a subgrade or incorporate topsoil into the underlying layer may vary depending on the planting specified.
 - A minimum organic content of 10% dry weight in planting beds, and 5% organic matter content in turf areas. Incorporate organic amendments to a minimum 8 inch depth except where tree roots or other natural features limit the depth of incorporation.
 - A pH between 6.0 and 8.0 or matching the pH of the undisturbed soil.
 - If blended topsoil is imported, then fines should be limited to 25% passing through a 200 sieve.
- Mulch planting beds with 2 inches of organic material
- Accomplish the required organic content, depth, and pH by returning native topsoil to the site, importing topsoil of sufficient organic content, and/or incorporating organic amendments. When using the option of incorporating amendments to meet the organic content requirement, use compost that meets the compost specification for Bioretention (See [BMP T7.30: Bioretention](#)), with the exception that the compost may have up to 35% biosolids or manure.
- The final composition and construction of the soil system will result in a natural selection or favoring of certain plant species over time. For example, incorporation of topsoil may favor grasses, while layering with mildly acidic, high-carbon amendments may favor more woody vegetation.
- Allow sufficient time in scheduling for topsoil spreading prior to seeding, sodding, or planting.
- Take care when applying topsoil to subsoils with contrasting textures. Sandy topsoil over clayey subsoil is a particularly poor combination, as water creeps along the junction between the soil layers and causes the topsoil to slough. If topsoil and subsoil are not properly bonded, water will not infiltrate the soil profile evenly and it will be difficult to establish vegetation. The best method to promote bonding is to actually work the topsoil into the layer below for a depth of at least 6 inches.

- Field exploration of the site shall be made to determine if there is surface soil of sufficient quantity and quality to justify stripping. Topsoil shall be friable and loamy (loam, sandy loam, silt loam, sandy clay loam, and/or clay loam). Avoid areas of natural groundwater recharge.
- Stripping shall be confined to the immediate construction area. A 4 to 6 inch stripping depth is common, but depth may vary depending on the particular soil. All surface runoff control structures shall be in place prior to stripping.
- Do not place topsoil while in a frozen or muddy condition, when the subgrade is excessively wet, or when conditions exist that may otherwise be detrimental to proper grading or proposed sodding or seeding.
- In any areas requiring grading, remove and stockpile the duff layer and topsoil on site in a designated, controlled area, not adjacent to public resources and critical areas. Reapply stockpiled topsoil to other portions of the site where feasible.
- Locate the topsoil stockpile so that it meets specifications and does not interfere with work on the site. It may be possible to locate more than one pile in proximity to areas where topsoil will be used.
- Stockpiling of topsoil shall occur in the following manner:
 - Side slopes of the stockpile shall not exceed 2H:1V.
 - Between October 1 and April 30:
 - An interceptor dike with gravel outlet and silt fence shall surround all topsoil stockpiles.
 - Within 2 days complete erosion control seeding, or covering stockpiles with clear plastic, or other mulching materials.
 - Between May 1 and September 30:
 - An interceptor dike with gravel outlet and silt fence shall surround all topsoil stockpiles if the stockpile will remain in place for a longer period of time than active construction grading.
 - Within 7 days complete erosion control seeding, or covering stockpiles with clear plastic, or other mulching materials.
- When native topsoil is to be stockpiled and reused, the following should apply to ensure that the mycorrhizal bacteria, earthworms, and other beneficial organisms will not be destroyed:
 - Reinstall topsoil within 4 to 6 weeks.
 - Do not allow the saturation of topsoil with water.
 - Do not use plastic covering.

Maintenance Standards

- Inspect stockpiles regularly, especially after large storm events. Stabilize any areas that have eroded.

- Establish soil quality and depth toward the end of construction and once established, protect from compaction, such as from large machinery use, and from erosion.
- Plant and mulch soil after installation.
- Leave plant debris or its equivalent on the soil surface to replenish organic matter.
- Reduce and adjust, where possible, the use of irrigation, fertilizers, herbicides and pesticides, rather than continuing to implement formerly established practices.

Washington State Department of Ecology

2024 Stormwater Management Manual for Western Washington (2024 SWMMWW)

Publication No. 24-10-013

BMP C130: Surface Roughening

Purpose

Surface roughening aids in the establishment of vegetative cover, reduces runoff velocity, increases infiltration, and provides for sediment trapping through the provision of a rough soil surface. Horizontal depressions are created by operating a tiller or other suitable equipment on the contour or by leaving slopes in a roughened condition by not fine grading them.

Use this BMP in conjunction with other BMPs such as [BMP C120: Temporary and Permanent Seeding](#), [BMP C121: Mulching](#), or [BMP C124: Sodding](#).

Conditions for Use

- All slopes steeper than 3H:1V and greater than 5 vertical feet require surface roughening to a depth of 2 to 4 inches prior to seeding.
- Areas that will not be stabilized immediately may be roughened to reduce runoff velocity until seeding takes place.
- Slopes with a stable rock face do not require roughening.
- Slopes where mowing is planned should not be excessively roughened.

Design and Installation Specifications

There are different methods for achieving a roughened soil surface on a slope, and the selection of an appropriate method depends on the type of slope. Roughening methods include stair-step grading, grooving, contour furrows, and tracking. See [Figure II-4.5: Surface Roughening by Tracking and Contour Furrows](#). Factors to be considered in choosing a roughening method are slope steepness, mowing requirements, and whether the slope is formed by cutting or filling.

- Disturbed areas that will not require mowing may be stair-step graded, grooved, or left rough after filling.
- Stair-step grading is particularly appropriate in soils containing large amounts of soft rock. Each "step" catches material that sloughs from above, and provides a level site where vegetation can become established. Stairs should be wide enough to work with standard earth moving equipment. Stair steps must be on contour or gullies will form on the slope.

- Areas that will be mowed (these areas should have slopes less steep than 3H:1V) may have small furrows left by disking, harrowing, raking, or seed-planting machinery operated on the contour.
- Graded areas with slopes steeper than 3H:1V but less than 2H:1V should be roughened before seeding. This can be accomplished in a variety of ways, including "track walking", or driving a crawler tractor up and down the slope, leaving a pattern of cleat imprints parallel to slope contours.
- Tracking is done by operating equipment up and down the slope to leave horizontal depressions in the soil.

Maintenance Standards

- Areas that are surface roughened should be seeded as quickly as possible.
- Regular inspections should be made of the area. If rills appear, they should be re-roughened and re-seeded immediately.

Figure II-4.5: Surface Roughening by Tracking and Contour Furrows

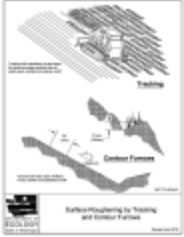

[Download PDF](#)

Washington State Department of Ecology

2024 Stormwater Management Manual for Western Washington (2024 SWMMWW)

Publication No. 24-10-013

BMP C131: Gradient Terraces

Purpose

Gradient terraces reduce erosion damage by intercepting surface runoff and conveying it to a stable outlet at a non-erosive velocity.

Conditions of Use

Gradient terraces are normally limited to bare land having a water erosion problem. They should not be constructed on deep sands or on soils that are too stony, steep, or shallow to permit practical and economical installation and maintenance. Gradient terraces may only be used where suitable outlets are or will be made available.

Design and Installation Specifications

- The maximum vertical spacing of gradient terraces should be determined by the following method:

$$VI = (0.8)s + y$$

Where:

VI = vertical interval in feet

s = land rise per 100 feet, expressed in feet

y = a soil and cover variable with values from 1.0 to 4.0

Values of “y” are influenced by soil erodibility and cover practices. The lower values are applicable to erosive soils where little to no residue is left on the surface. The higher value is applicable only to erosion-resistant soils where a large amount of residue (1.5 tons of straw per acre equivalent) is on the surface.

- The minimum constructed cross-section should meet the design dimensions.
- The top of the constructed ridge should not be lower at any point than the design elevation plus the specified overfill for settlement. The opening at the outlet end of the terrace should have a cross section equal to that specified for the terrace channel.
- Channel grades may be either uniform or variable with a maximum grade of 0.6 feet per 100 feet length (0.6%). For short distances, terrace grades may be increased to improve alignment. The channel velocity should not exceed that which is nonerosive for the soil type.

- All gradient terraces should have adequate outlets. Such an outlet may be a grassed waterway, vegetated area, or tile outlet. In all cases the outlet must convey runoff from the terrace or terrace system to a point where the outflow will not cause damage. Vegetative cover and energy dissipators should be used in the outlet channel.
- The design elevation of the water surface of the terrace should not be lower than the design elevation of the water surface in the outlet at their junction, when both are operating at design flow.
- Vertical spacing determined by the above methods may be increased as much as 0.5 feet or 10 percent, whichever is greater, to provide better alignment or location, to avoid obstacles, to adjust for equipment size, or to reach a satisfactory outlet. The contributing drainage area above the terrace should not exceed the area that would be drained by a terrace with normal spacing.
- The terrace should have enough capacity to handle the peak runoff expected from a 2-year, 24-hour design storm without overtopping.
- The terrace cross-section should be proportioned to fit the land slope.
- The ridge height should include a reasonable settlement factor.
- The ridge should have a minimum top width of 3 feet at the design height.
- The minimum cross-sectional area of the terrace channel should be 8 square feet for land slopes of 5 percent or less, 7 square feet for slopes from 5 to 8 percent, and 6 square feet for slopes steeper than 8 percent. The terrace can be constructed wide enough to be maintained using a small vehicle.

Maintenance Standards

Maintenance should be performed as needed. Terraces should be inspected regularly; at least once per year, and after large storm events.

Figure II-4.6: Gradient Terraces



[Download PDF](#)

Washington State Department of Ecology

2024 Stormwater Management Manual for Western Washington (2024 SWMMWW)

Publication No. 24-10-013

BMP C140: Dust Control

Purpose

Dust control prevents wind transport of dust from disturbed soil surfaces onto roadways, into drainage systems, and into surface waters.

Conditions of Use

Use dust control in areas (including roadways) subject to surface and air movement of dust where on-site or off-site impacts to roadways, drainage systems, or surface waters are likely.

Design and Installation Specifications

- Vegetate or mulch areas that will not receive vehicle traffic. In areas where planting, mulching, or paving is impractical, apply gravel or landscaping rock.
- Limit dust generation by clearing only those areas where immediate activity will take place, leaving the remaining area(s) in the original condition. Maintain the original ground cover as long as practical.
- Construct natural or artificial windbreaks or windscreens. These may be designed as enclosures for small dust sources.
- Sprinkle the site with water until the surface is wet. Repeat as needed. To prevent carryout of mud onto the street, refer to [BMP C105: Stabilized Construction Access](#) and [BMP C106: Wheel Wash](#).
- Irrigation water can be used for dust control. Irrigation systems should be installed as a first step on sites where dust control is a concern.
- Spray exposed soil areas with a dust palliative, following the manufacturer's instructions and cautions regarding handling and application. Used oil is prohibited from use as a dust suppressant. Local jurisdictions may approve other dust palliatives such as calcium chloride or PAM.
- PAM ([BMP C126: Polyacrylamide \(PAM\) for Soil Erosion Protection](#)) added to water at a rate of 0.5 pounds per 1,000 gallons of water per acre and applied from a water truck is more effective than water alone. This is due to the increased infiltration of water into the soil and reduced evaporation. In addition, small soil particles are bonded together and are not as easily transported by wind. Adding PAM may reduce the quantity of water needed for dust control.

Note that the application rate specified here applies to this BMP, and is not the same application rate that is specified in [BMP C126: Polyacrylamide \(PAM\) for Soil Erosion Protection](#), but the downstream protections still apply.

Refer to [BMP C126: Polyacrylamide \(PAM\) for Soil Erosion Protection](#) for conditions of use. PAM shall not be directly applied to water or allowed to enter a water body. PAM use shall be reviewed and approved by the local permitting authority and discharge of PAM may be a basis for penalties per [RCW 90.48.080](#).

- Contact your local Air Pollution Control Authority for guidance and training on other dust control measures. Compliance with the local Air Pollution Control Authority constitutes compliance with this BMP. See the following website for more information:

<https://ecology.wa.gov/About-us/Our-role-in-the-community/Partnerships-committees/Clean-air-agencies>

- Use vacuum street sweepers.
- Remove mud and other dirt promptly so it does not dry and then turn into dust.
- Techniques that can be used for unpaved roads and lots include:
 - Lower speed limits. High vehicle speed increases the amount of dust stirred up from unpaved roads and lots.
 - Upgrade the road surface strength by improving particle size, shape, and mineral types that make up the surface and base materials.
 - Add surface gravel to reduce the source of dust emission. Limit the amount of fine particles (those smaller than .075 mm) to 10 to 20 percent.
 - Use geotextile fabrics to increase the strength of new roads or roads undergoing reconstruction.
 - Encourage the use of alternate, paved routes, if available.
 - Apply chemical dust suppressants using the admix method, blending the product with the top few inches of surface material. Suppressants may also be applied as surface treatments.
 - Limit dust-generating work on windy days.
 - Pave unpaved permanent roads and other trafficked areas.

Maintenance Standards

Respray area as necessary to keep dust to a minimum.

Washington State Department of Ecology

2024 Stormwater Management Manual for Western Washington (2024 SWMMWW)

Publication No. 24-10-013

BMP C151: Concrete Handling

Purpose

Concrete work can generate process water and slurry that contain fine particles and high pH, both of which can violate water quality standards in the receiving water. Concrete spillage or concrete discharge to waters of the State is prohibited. Use this BMP to minimize and eliminate concrete, concrete process water, and concrete slurry from entering waters of the State.

Conditions of Use

Any time concrete is used, utilize these management practices. Concrete construction project components include, but are not limited to:

- Curbs
- Sidewalks
- Roads
- Bridges
- Foundations
- Floors
- Runways

Disposal options for concrete, in order of preference are:

1. Off-site disposal
2. Concrete wash-out areas (see [BMP C154: Concrete Washout Area](#))
3. De minimus washout to formed areas awaiting concrete

Design and Installation Specifications

- Wash concrete truck drums at an approved off-site location or in designated concrete washout areas only. Do not wash out concrete trucks onto the ground (including formed areas awaiting concrete), or into storm drains, open ditches, streets, or streams. Refer to [BMP C154: Concrete Washout Area](#) for information on concrete washout areas.

- Return unused concrete remaining in the truck and pump to the originating batch plant for recycling. Do not dump excess concrete on site, except in designated concrete washout areas as allowed in [BMP C154: Concrete Washout Area](#).
- Wash small concrete handling equipment (e.g. hand tools, screeds, shovels, rakes, floats, trowels, and wheelbarrows) into designated concrete washout areas or into formed areas awaiting concrete pour.
- At no time shall concrete be washed off into the footprint of an area where an infiltration feature will be installed.
- Wash equipment difficult to move, such as concrete paving machines, in areas that do not directly drain to natural or constructed stormwater conveyance or potential infiltration areas.
- Do not allow washwater from areas, such as concrete aggregate driveways, to drain directly (without detention or treatment) to natural or constructed stormwater conveyances.
- Contain washwater and leftover product in a lined container when no designated concrete washout areas (or formed areas, allowed as described above) are available. Dispose of contained concrete and concrete washwater (process water) properly.
- Always use forms or solid barriers for concrete pours, such as pilings, within 15-feet of surface waters.
- Refer to [BMP C252: Treating and Disposing of High pH Water](#) for pH adjustment requirements.
- Refer to the Construction Stormwater General Permit (CSWGP) for pH monitoring requirements if the project involves one of the following activities:
 - Significant concrete work (as defined in the CSWGP).
 - The use of soils amended with (but not limited to) Portland cement-treated base, cement kiln dust or fly ash.
 - Discharging stormwater to segments of water bodies on the 303(d) list (Category 5) for high pH.

Maintenance Standards

Check containers for holes in the liner daily during concrete pours and repair the same day.

Washington State Department of Ecology

2024 Stormwater Management Manual for Western Washington (2024 SWMMWW)

Publication No. 24-10-013

BMP C152: Sawcutting and Surfacing Pollution Prevention

Purpose

Sawcutting and surfacing operations generate slurry and process water that contain fine particles and have a high pH (concrete cutting), both of which can violate the water quality standards in the receiving water. Concrete spillage or concrete discharge to waters of the State is prohibited. Use this BMP to minimize and eliminate process water and slurry created by sawcutting or surfacing from entering waters of the State.

Conditions of Use

Utilize these management practices anytime sawcutting or surfacing operations take place. Sawcutting and surfacing operations include, but are not limited to:

- Sawing
- Coring
- Grinding
- Roughening
- Hydro-demolition
- Bridge and road surfacing

Design and Installation Specifications

- Vacuum slurry and cuttings during cutting and surfacing operations.
- Slurry and cuttings shall not remain on permanent concrete or asphalt pavement overnight.
- Slurry and cuttings shall not drain to any natural or constructed drainage conveyance including stormwater systems. This may require temporarily blocking catch basins.
- Dispose of collected slurry and cuttings in a manner that does not violate groundwater or surface water quality standards.
- Do not allow process water generated during hydro-demolition, surface roughening, or similar operations to drain to any natural or constructed drainage conveyance including stormwater systems. Dispose of process water in a manner that does not violate groundwater or surface water quality standards.

- Handle and dispose of cleaning waste material and demolition debris in a manner that does not cause contamination of water. Dispose of sweeping material from a pick-up sweeper at an appropriate disposal site.

Maintenance Standards

Continually monitor operations to determine whether slurry, cuttings, or process water could enter waters of the state. If inspections show that a violation of water quality standards could occur, stop operations and immediately implement preventive measures such as berms, barriers, secondary containment, and/or vacuum trucks.

Washington State Department of Ecology

2024 Stormwater Management Manual for Western Washington (2024 SWMMWW)

Publication No. 24-10-013

BMP C153: Material Delivery, Storage, and Containment

Purpose

Prevent, reduce, or eliminate the discharge of pollutants to the stormwater system or watercourses from material delivery and storage. Minimize the storage of hazardous materials on-site, store materials in a designated area, and install secondary containment.

Conditions of Use

Use at construction sites with delivery and storage of the following materials:

- Petroleum products such as fuel, oil and grease
- Soil stabilizers and binders (e.g., polyacrylamide)
- Fertilizers, pesticides, and herbicides
- Detergents
- Asphalt and concrete compounds
- Hazardous chemicals such as acids, lime, adhesives, paints, solvents, and curing compounds
- Any other material that may be detrimental if released to the environment

Design and Installation Specifications

- The temporary storage area should be located away from vehicular traffic, near the construction entrance(s), and away from waterways or storm drains.
- Safety Data Sheets (SDS) should be supplied for all materials stored. Chemicals should be kept in their original labeled containers.
- Hazardous material storage on-site should be minimized.
- Hazardous materials should be handled as infrequently as possible.
- During the wet weather season (October 1 – April 30), consider storing materials in a covered area.
- Materials should be stored in secondary containments, such as an earthen dike, horse trough, or even a children's wading pool for non-reactive materials such as detergents, oil, grease, and paints. Small amounts

of material may be secondarily contained in “bus boy” trays or concrete mixing trays.

- Do not store chemicals, drums, or bagged materials directly on the ground. Place these items on a pallet and, when possible, within secondary containment.
- If drums must be kept uncovered, store them at a slight angle to reduce ponding of rainwater on the lids to reduce corrosion. Domed plastic covers are inexpensive and snap to the top of drums, preventing water from collecting.
- Liquids, petroleum products, and substances listed in 40 CFR Parts 110, 117, or 302 shall be stored in approved containers and drums and shall not be overfilled. Containers and drums shall be stored in temporary secondary containment facilities.
- Temporary secondary containment facilities shall provide for a spill containment volume able to contain 10% of the total enclosed container volume of all containers, or 110% of the capacity of the largest container within its boundary, whichever is greater.
- Secondary containment facilities shall be impervious to the materials stored therein for a minimum contact time of 72 hours.
- Sufficient separation should be provided between stored containers to allow for spill cleanup and emergency response access.
- During the wet weather season (Oct 1 – April 30), each secondary containment facility shall be covered during non-working days.
- Secondary containment facilities shall be covered at all times, except when in active use.
- Keep material storage areas clean, organized, and equipped with an ample supply of appropriate spill clean-up material (spill kit).
- The spill kit should include, at a minimum:
 - 1 - Water resistant nylon bag
 - 3 - Oil absorbent socks 3"x 4'
 - 2 - Oil absorbent socks 3"x 10'
 - 12 - Oil absorbent pads 17"x19"
 - 1 - Pair splash resistant goggles
 - 3 - Pairs nitrile gloves
 - 10 - Disposable bags with ties
 - Instructions

Maintenance Standards

- Secondary containment facilities shall be maintained free of accumulated rainwater and spills. In the event of spills or leaks, accumulated rainwater and spills shall be collected and placed into drums. These liquids shall be handled as hazardous waste unless testing determines them to be non-hazardous.
- Re-stock spill kit materials as needed.

Washington State Department of Ecology

2024 Stormwater Management Manual for Western Washington (2024 SWMMWW)

Publication No. 24-10-013

BMP C154: Concrete Washout Area

Purpose

Prevent or reduce the discharge of pollutants from concrete waste to stormwater by conducting washout off-site, or performing on-site washout in a designated area.

Conditions of Use

Concrete washout areas are implemented on construction projects where:

- Concrete is used as a construction material
- It is not possible to dispose of all concrete wastewater and washout off-site (ready mix plant, etc.).
- Concrete truck drums are washed on-site.

Note that auxiliary concrete truck components (e.g. chutes and hoses) and small concrete handling equipment (e.g. hand tools, screeds, shovels, rakes, floats, trowels, and wheelbarrows) may be washed into formed areas awaiting concrete pour.

At no time shall concrete be washed off into the footprint of an area where an infiltration feature will be installed.

Design and Installation Specifications

Implementation

- Perform washout of concrete truck drums at an approved off-site location or in designated concrete washout areas only.
- Do not wash out concrete onto non-formed areas, or into storm drains, open ditches, streets, or streams.
- Wash equipment difficult to move, such as concrete paving machines, in areas that do not directly drain to natural or constructed stormwater conveyance or potential infiltration areas.
- Do not allow excess concrete to be dumped on-site, except in designated concrete washout areas as allowed above.
- Concrete washout areas may be prefabricated concrete washout containers, or self-installed structures (above-grade or below-grade).

- Prefabricated containers are most resistant to damage and protect against spills and leaks. Companies may offer delivery service and provide regular maintenance and disposal of solid and liquid waste.
- If self-installed concrete washout areas are used, below-grade structures are preferred over above-grade structures because they are less prone to spills and leaks.
- Self-installed above-grade structures should only be used if excavation is not practical.
- Concrete washout areas shall be constructed and maintained in sufficient quantity and size to contain all liquid and concrete waste generated by washout operations.

Education

- Discuss the concrete management techniques described in this BMP with the ready-mix concrete supplier before any deliveries are made.
- Educate employees and subcontractors on the concrete waste management techniques described in this BMP.
- Arrange for the contractor's superintendent or Certified Erosion and Sediment Control Lead (CESCL) to oversee and enforce concrete waste management procedures.
- A sign should be installed adjacent to each concrete washout area to inform concrete equipment operators to utilize the proper facilities.

Contracts

Incorporate requirements for concrete waste management into concrete supplier and subcontractor agreements.

Location and Placement

- Locate concrete washout areas at least 50 feet from sensitive areas such as storm drains, open ditches, water bodies, or wetlands.
- Allow convenient access to the concrete washout area for concrete trucks, preferably near the area where the concrete is being poured.
- If trucks need to leave a paved area to access the concrete washout area, prevent track-out with a pad of rock or quarry spalls (see [BMP C105: Stabilized Construction Access](#)). These areas should be far enough away from other construction traffic to reduce the likelihood of accidental damage and spills.
- The number of concrete washout areas you install should depend on the expected demand for storage capacity.
- On large sites with extensive concrete work, concrete washout areas should be placed in multiple locations for ease of use by concrete truck drivers.

Concrete Truck Washout Procedures

- Washout of concrete truck drums shall be performed in designated concrete washout areas only.
- Concrete washout from concrete pumper bins can be washed into concrete pumper trucks and discharged into designated concrete washout areas or properly disposed of off-site.

Concrete Washout Area Installation

- Concrete washout areas should be constructed as shown in the figures below, with a recommended minimum length and minimum width of 10 ft, but with sufficient quantity and volume to contain all liquid and concrete waste generated by washout operations.
- Plastic lining material should be a minimum of 10 mil polyethylene sheeting and should be free of holes, tears, or other defects that compromise the impermeability of the material.
- Lath and flagging should be commercial type.
- Liner seams shall be installed in accordance with manufacturers' recommendations.
- Soil base shall be prepared free of rocks or other debris that may cause tears or holes in the plastic lining material.

Maintenance Standards

Inspection and Maintenance

- Inspect and verify that concrete washout areas are in place prior to the commencement of concrete work.
- Once concrete wastes are washed into the designated washout area and allowed to harden, the concrete should be broken up, removed, and disposed of per applicable solid waste regulations. Dispose of hardened concrete on a regular basis.
- During periods of concrete work, inspect the concrete washout areas daily to verify continued performance.
 - Check overall condition and performance.
 - Check remaining capacity (% full).
 - If using self-installed concrete washout areas, verify plastic liners are intact and sidewalls are not damaged.
 - If using prefabricated containers, check for leaks.
- Maintain the concrete washout areas to provide adequate holding capacity with a minimum freeboard of 12 inches.

- Concrete washout areas must be cleaned, or new concrete washout areas must be constructed and ready for use once the concrete washout area is 75% full.
- If the concrete washout area is nearing capacity, vacuum and dispose of the waste material in an approved manner.
 - Do not discharge liquid or slurry to waterways, storm drains or directly onto ground.
 - Do not discharge to the sanitary sewer without local approval.
 - Place a secure, non-collapsing, non-water collecting cover over the concrete washout area prior to predicted wet weather to prevent accumulation and overflow of precipitation.
 - Remove and dispose of hardened concrete and return the structure to a functional condition. Concrete may be reused on-site or hauled away for disposal or recycling.
- When you remove materials from a self-installed concrete washout area, build a new structure; or, if the previous structure is still intact, inspect for signs of weakening or damage, and make any necessary repairs. Re-line the structure with new plastic after each cleaning.

Removal of Concrete Washout Areas

- When concrete washout areas are no longer required for the work, the hardened concrete, slurries and liquids shall be removed and properly disposed of.
- Materials used to construct concrete washout areas shall be removed from the site of the work and disposed of or recycled.
- Holes, depressions or other ground disturbance caused by the removal of the concrete washout areas shall be backfilled, repaired, and stabilized to prevent erosion.

Figure II-4.7: Concrete Washout Area with Wood Planks

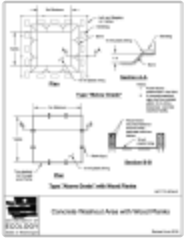

[Download PDF](#)

Figure II-4.8: Concrete Washout Area with Straw Bales

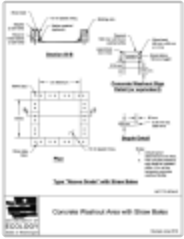

[Download PDF](#)

Figure II-4.9: Prefabricated Concrete Washout Container with Ramp



[Download PDF](#)

Washington State Department of Ecology

2024 Stormwater Management Manual for Western Washington (2024 SWMMWW)

Publication No. 24-10-013

BMP C160: Certified Erosion and Sediment Control Lead

Purpose

The project proponent designates at least one person as the responsible representative in charge of erosion and sediment control (ESC) and water quality protection. The designated person shall be responsible for ensuring compliance with all local, state, and federal erosion and sediment control and water quality requirements. Construction sites one acre or larger that discharge to waters of the State must designate a Certified Erosion and Sediment Control Lead (CESCL) as the responsible representative.

Conditions of Use

A CESCL shall be made available on projects one acre or larger that discharge stormwater to surface waters of the state. Sites less than one acre may have a person without CESCL certification conduct inspections.

The CESCL shall:

- Have a current certificate proving attendance in an ESC training course that meets the minimum ESC training and certification requirements established by Ecology.

Ecology has provided the minimum requirements for CESCL course training, as well as a list of ESC training and certification providers at:

<https://ecology.wa.gov/Regulations-Permits/Permits-certifications/Certified-erosion-sediment-control>

OR

- Be a Certified Professional in Erosion and Sediment Control (CPESC). For additional information go to:

<http://www.envirocertintl.org/cpesc/>

Specifications

- CESCL certification shall remain valid for three years.
- The CESCL shall have authority to act on behalf of the contractor or project proponent and shall be available, or on-call, 24 hours per day throughout the period of construction.
- The Construction SWPPP shall include the name, telephone number, fax number, and address of the designated CESCL. See [II-3 Construction Stormwater Pollution Prevention Plans \(Construction SWPPPs\)](#).

- A CESCL may provide inspection and compliance services for multiple construction projects in the same geographic region, but must be on site whenever earthwork activities are occurring that could generate release of turbid water.
- Duties and responsibilities of the CESCL shall include, but are not limited to, the following:
 - Maintaining a permit file on site at all times which includes the Construction SWPPP and any associated permits and plans.
 - Directing BMP installation, inspection, maintenance, modification, and removal.
 - Updating all project drawings and the Construction SWPPP with changes made.
 - Completing any sampling requirements including reporting results using electronic Discharge Monitoring Reports (WebDMR).
 - Facilitating, participating in, and taking corrective actions resulting from inspections performed by outside agencies or the owner.
 - Keeping daily logs and inspection reports. Inspection reports should include:
 - Inspection date/time.
 - Weather information; general conditions during inspection and approximate amount of precipitation since the last inspection.
 - Visual monitoring results, including a description of discharged stormwater. The presence of suspended sediment, turbid water, discoloration, and oil sheen shall be noted, as applicable.
 - Any water quality monitoring performed during inspection.
 - General comments and notes, including a brief description of any BMP repairs, maintenance or installations made as a result of the inspection.
 - A summary or list of all BMPs implemented, including observations of all ESC structures or practices. The following shall be noted:
 1. Locations of BMPs inspected.
 2. Locations of BMPs that need maintenance.
 3. Locations of BMPs that failed to operate as designed or intended.
 4. Locations of where additional or different BMPs are required.

BMP C162: Scheduling

Purpose

Sequencing a construction project can reduce the amount and duration of soil exposed to erosion by wind, rain, runoff, and vehicle tracking.

Conditions of Use

The construction sequence schedule is an orderly listing of all major land-disturbing activities together with the necessary erosion and sediment control (ESC) measures planned for the project. This type of schedule guides the contractor on work to be done before other work is started so that serious erosion and sedimentation problems can be avoided.

Following a specified work schedule that coordinates the timing of land-disturbing activities and the installation of control measures is perhaps the most cost-effective way of controlling erosion during construction. The removal of ground cover leaves a site vulnerable to erosion. Construction sequencing that limits land clearing, provides timely installation of ESC BMPs, and restores protective cover quickly can significantly reduce the erosion potential of a site.

Design Considerations

- Minimize construction during rainy periods.
- Schedule projects to disturb only small portions of the site at any one time. Complete grading as soon as possible. Immediately stabilize the disturbed portion before grading the next portion. Practice staged seeding in order to revegetate cut and fill slopes as the work progresses.

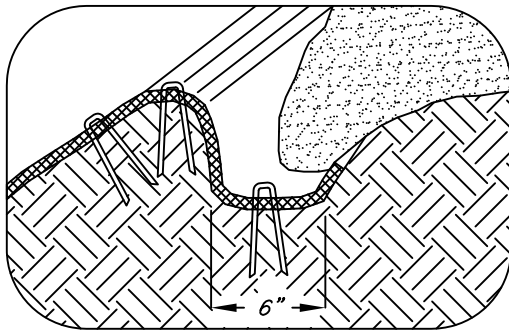

LONGITUDINAL ANCHOR TRENCH

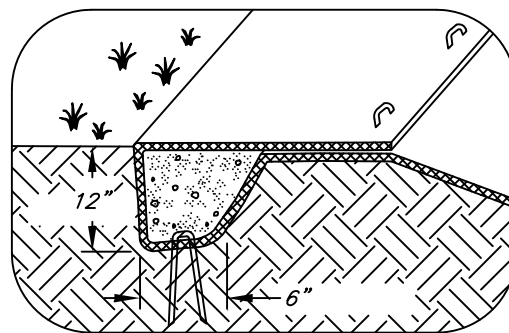

TERMINAL SLOPE AND CHANNEL ANCHOR TRENCH

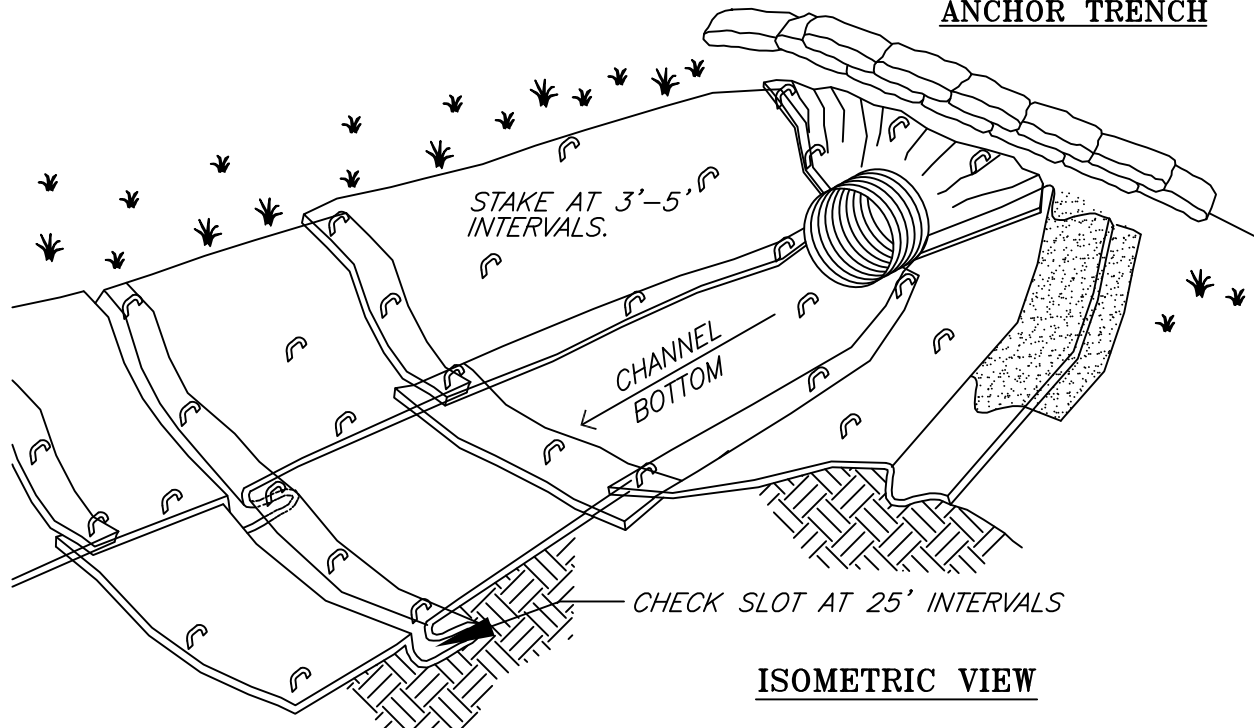

ISOMETRIC VIEW

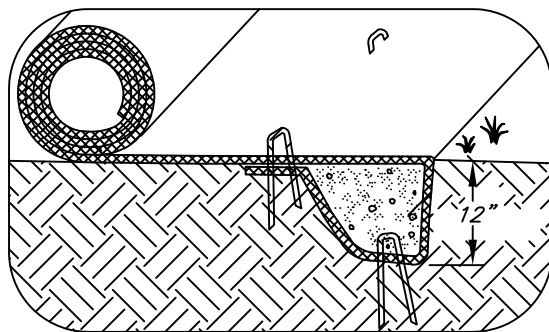

INITIAL CHANNEL ANCHOR TRENCH

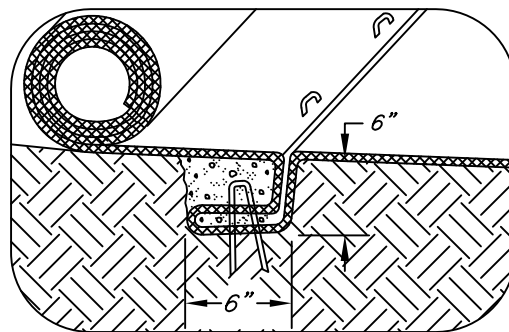

INTERMITTENT CHECK SLOT

Notes:

1. Check slots to be constructed per manufacturers specifications.
2. Staking or stapling layout per manufacturers specifications.

(Clackamas County et al., 2008)



DEPARTMENT OF
ECOLOGY
State of Washington

Channel Installation

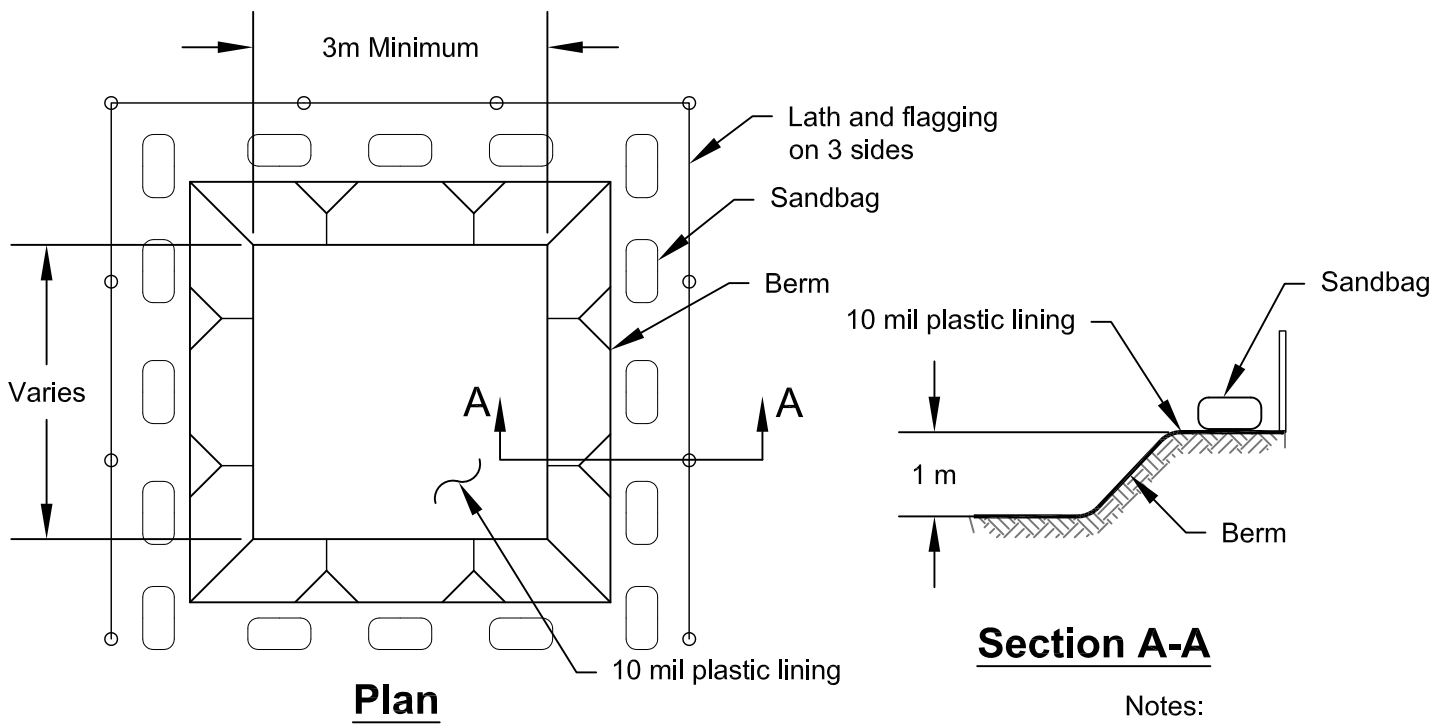

Type "Below Grade"

Notes:

1. Actual layout determined in the field.
2. A concrete washout sign shall be installed within 10 m of the temporary concrete washout facility.

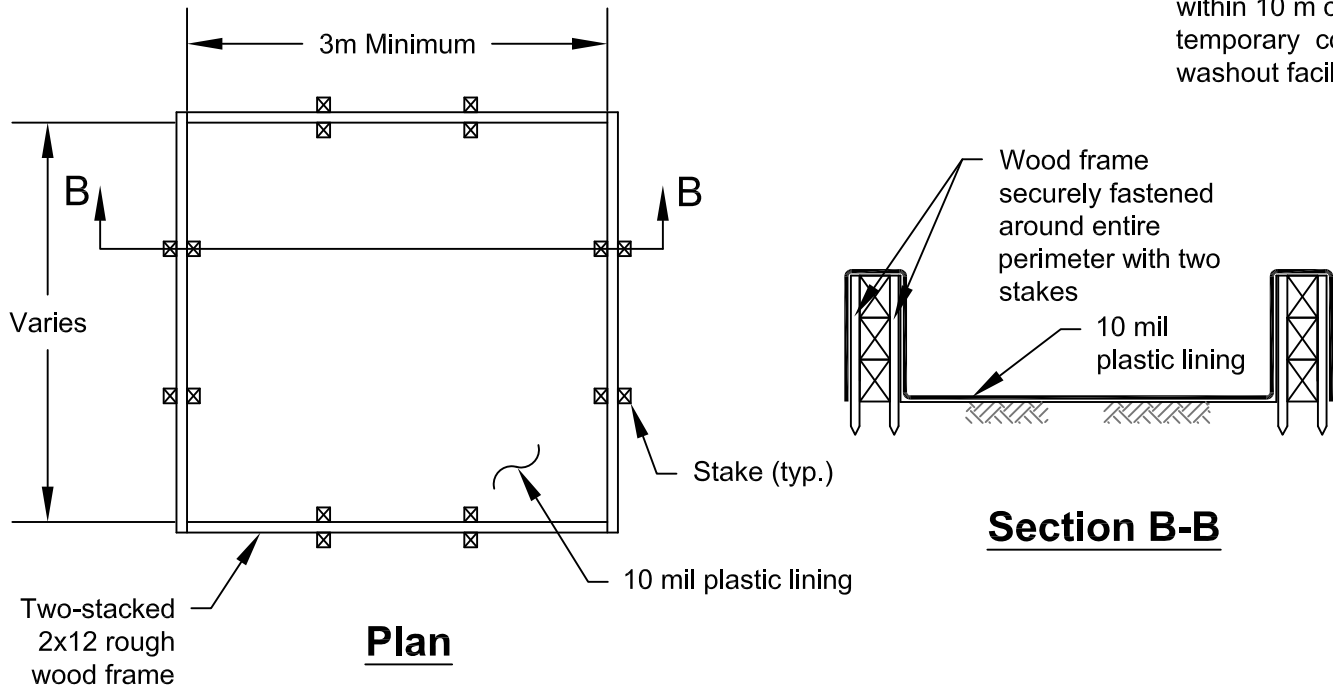

Type "Above Grade" with Wood Planks

NOT TO SCALE



DEPARTMENT OF
ECOLOGY
State of Washington

Concrete Washout Area with Wood Planks

Revised June 2016

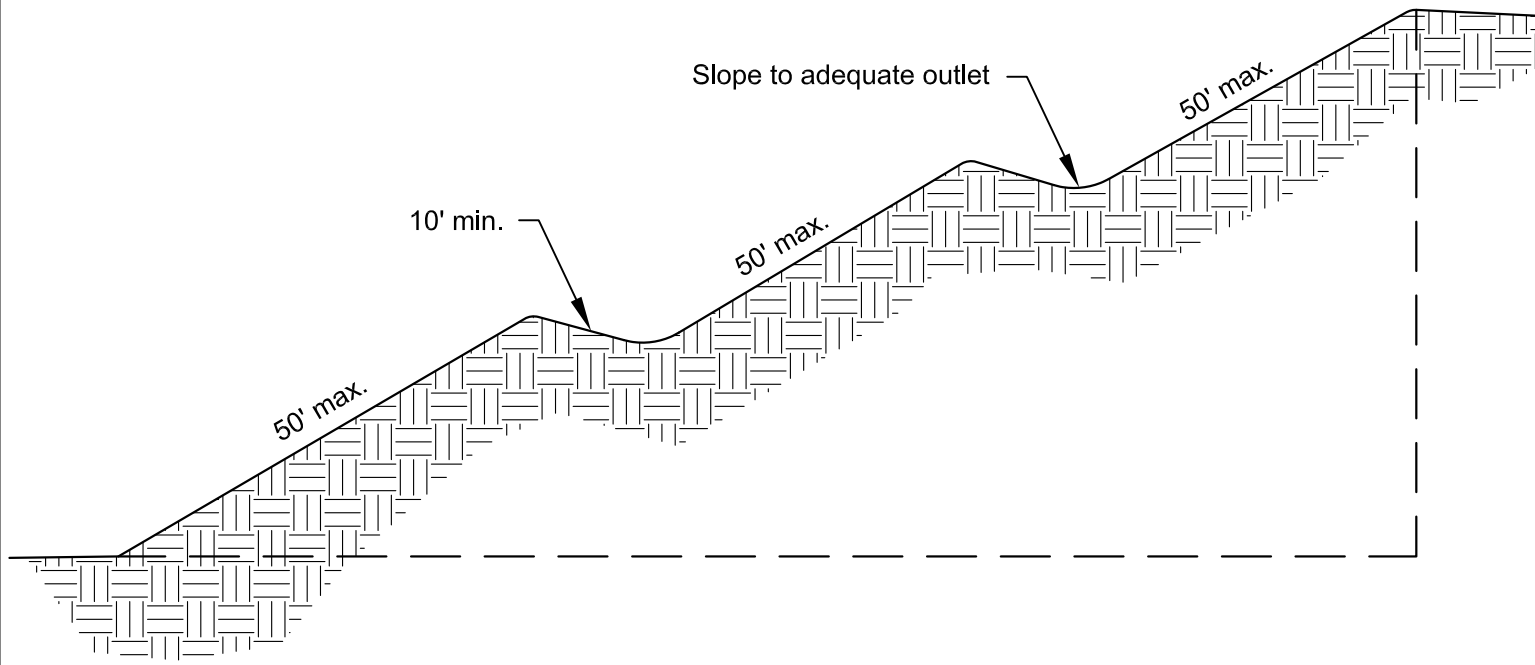

NOT TO SCALE



DEPARTMENT OF
ECOLOGY
State of Washington

Gradient Terraces

Revised June 2016

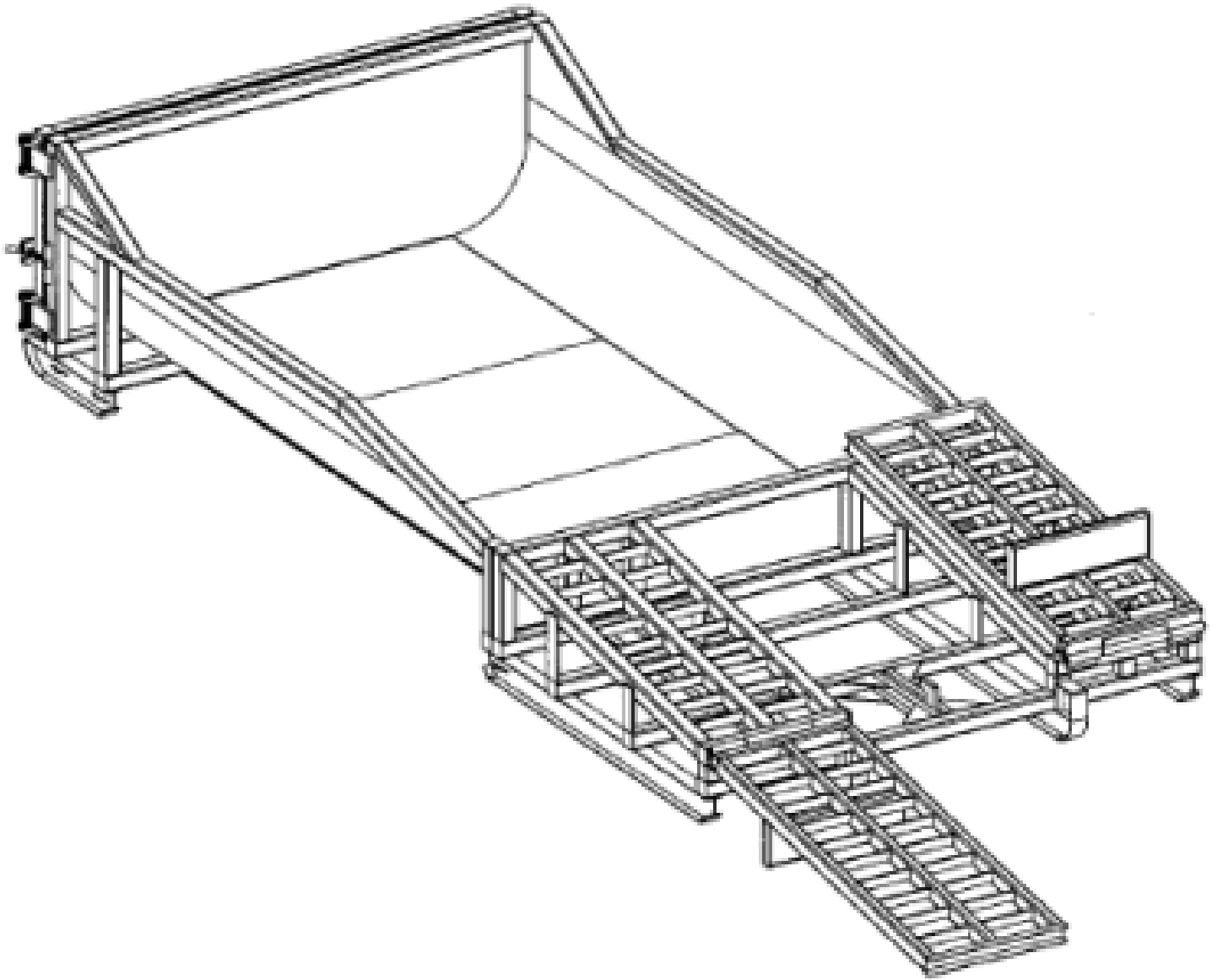

NOT TO SCALE



DEPARTMENT OF
ECOLOGY
State of Washington

Prefabricated Concrete Washout Container with Ramp

Revised June 2016

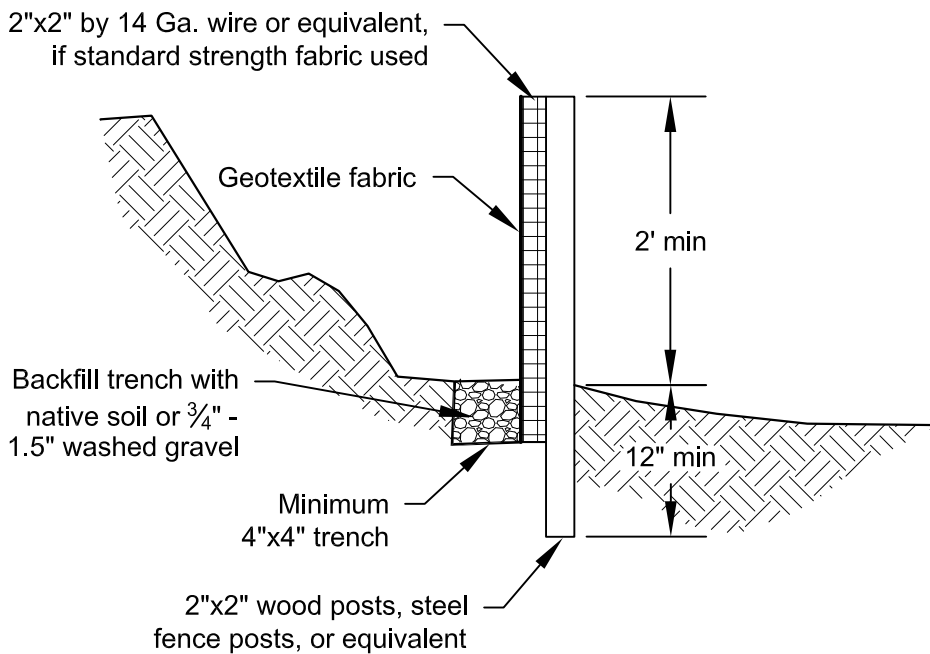
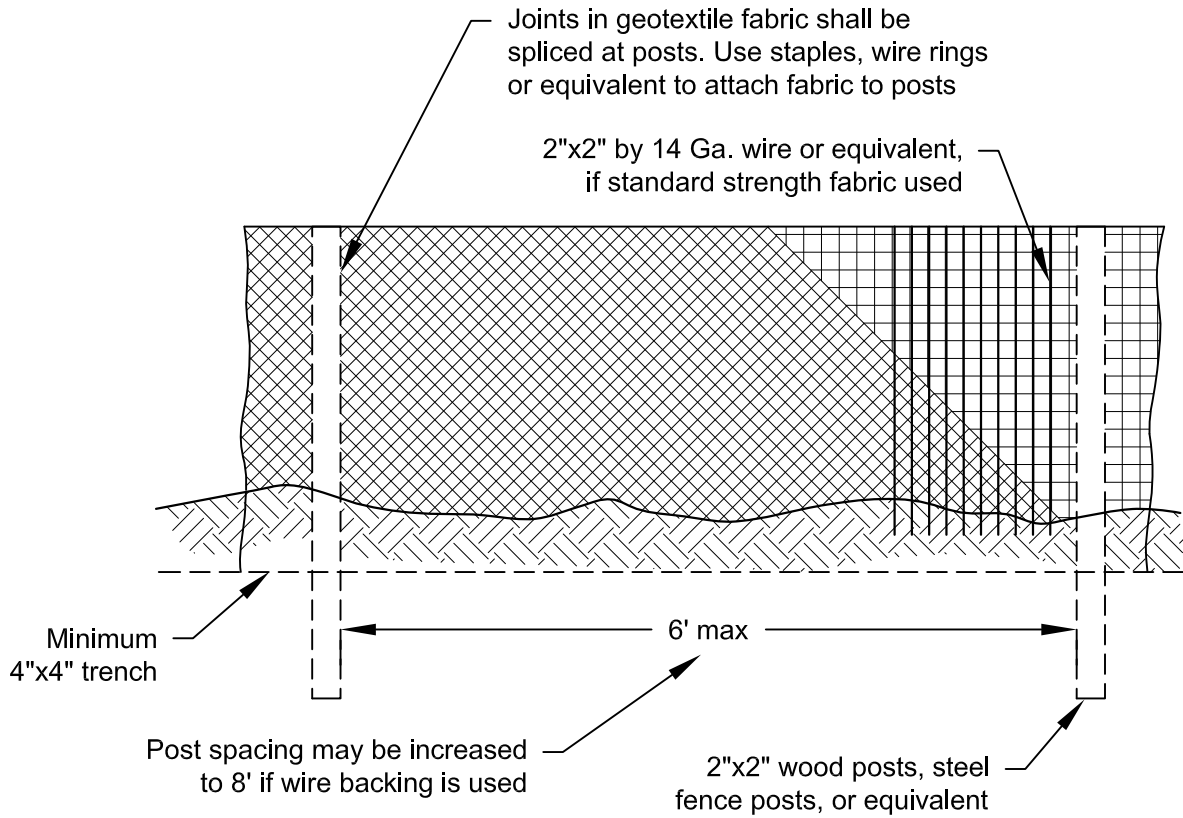

NOT TO SCALE



DEPARTMENT OF
ECOLOGY
 State of Washington

Silt Fence

Revised July 2017

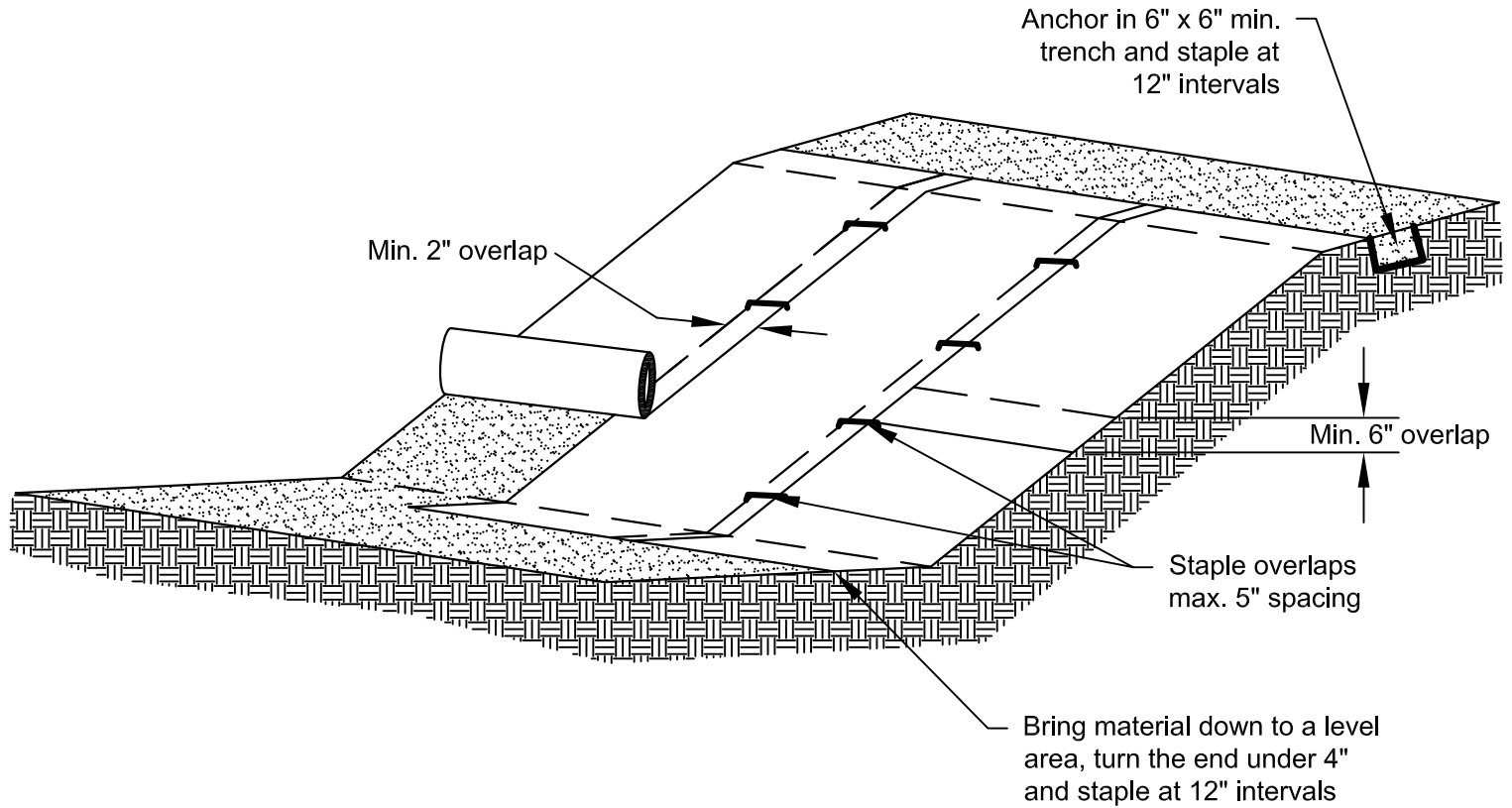

Notes:

1. Slope surface shall be smooth before placement for proper soil contact.
2. Stapling pattern as per manufacturer's recommendations.
3. Do not stretch blankets/matting tight - allow the rolls to mold to any irregularities.
4. For slopes less than 3H:1V, rolls may be placed in horizontal strips.
5. If there is a berm at the top of the slope, anchor upslope of the berm.
6. Lime, fertilize, and seed before installation. Planting of shrubs, trees, etc. should occur after installation.

NOT TO SCALE



DEPARTMENT OF
ECOLOGY
 State of Washington

Slope Installation

Revised June 2016

Existing Road

Install driveway
culvert if there is a
roadside ditch present

4" - 8" quarry
spalls

Geotextile

100' min.

Notes:

1. Driveway shall meet the requirements of the permitting agency.
2. It is recommended that the access be crowned so that runoff drains off the pad.

12" minimum thickness

15' min.

Provide full width
of ingress/egress
area



DEPARTMENT OF
ECOLOGY
State of Washington

Stabilized Construction Access

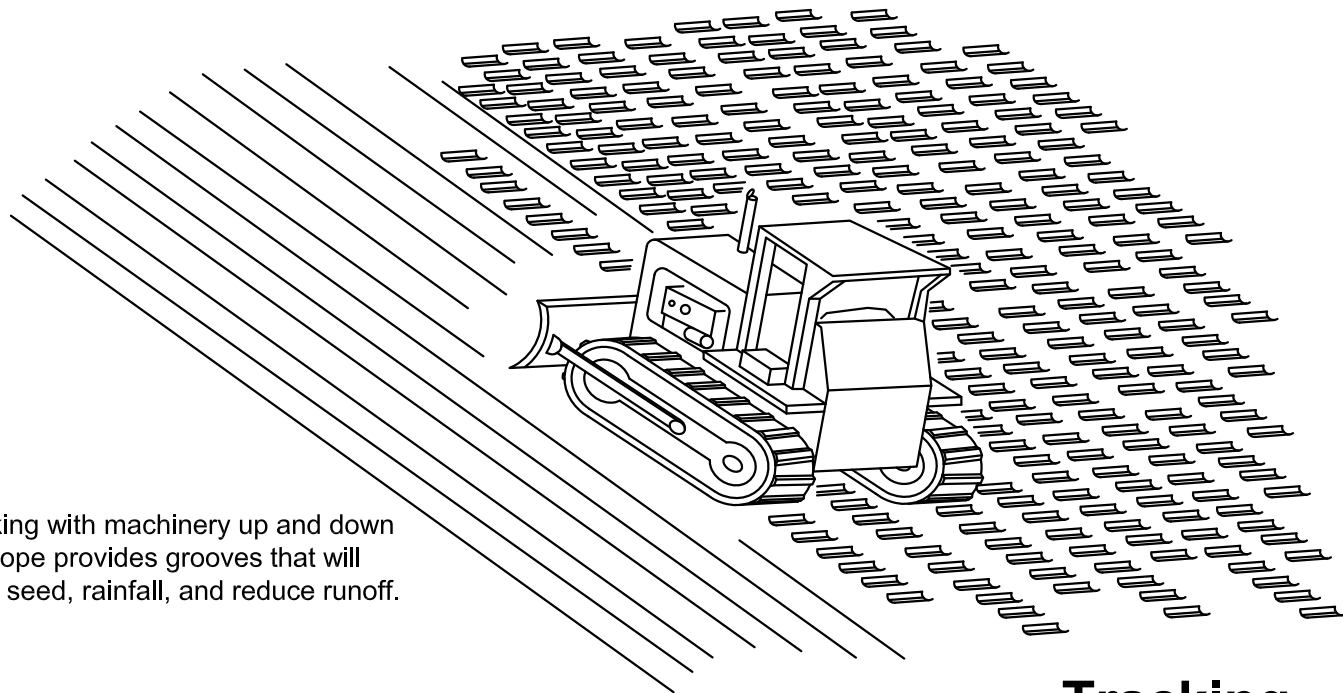

Tracking with machinery up and down the slope provides grooves that will catch seed, rainfall, and reduce runoff.

Tracking

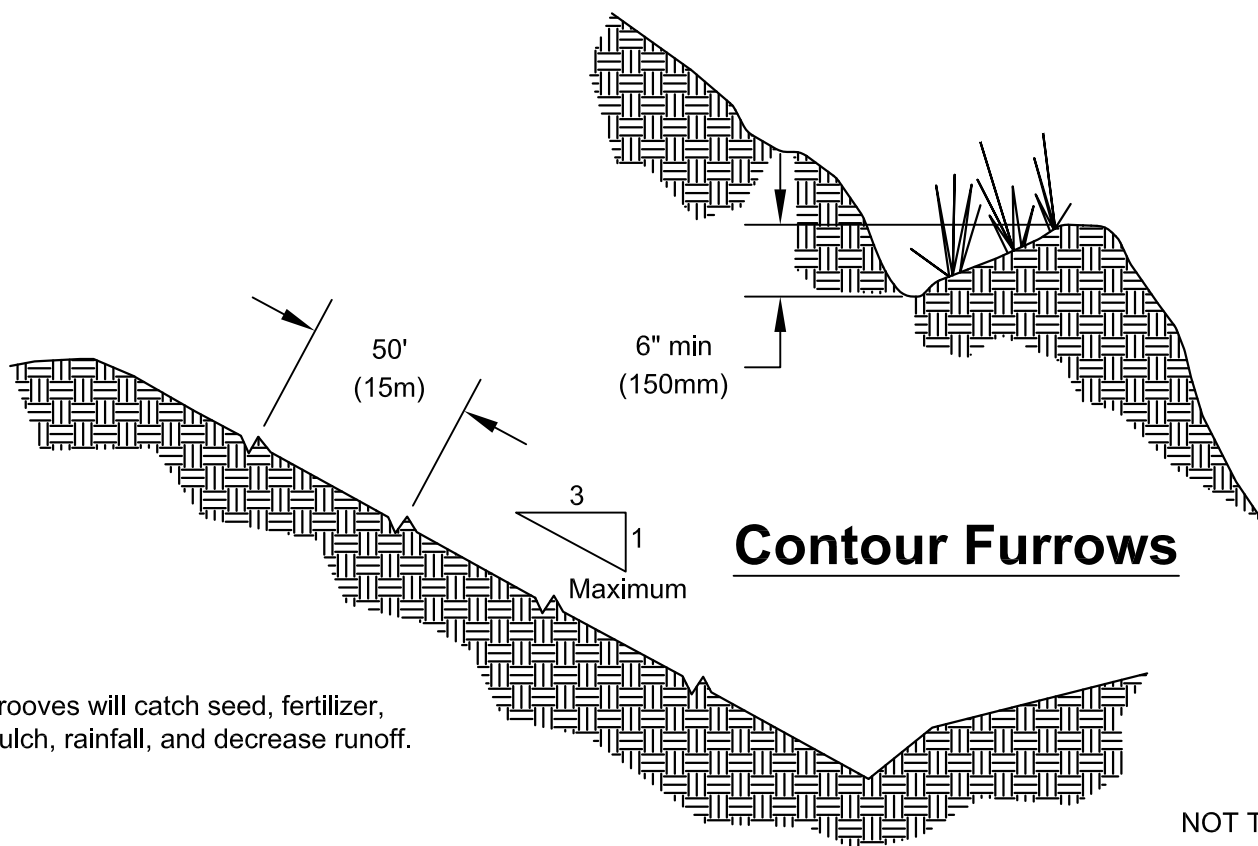

Contour Furrows

Grooves will catch seed, fertilizer, mulch, rainfall, and decrease runoff.

NOT TO SCALE



DEPARTMENT OF
ECOLOGY

State of Washington

Surface Roughening by Tracking and Contour Furrows

Revised June 2016

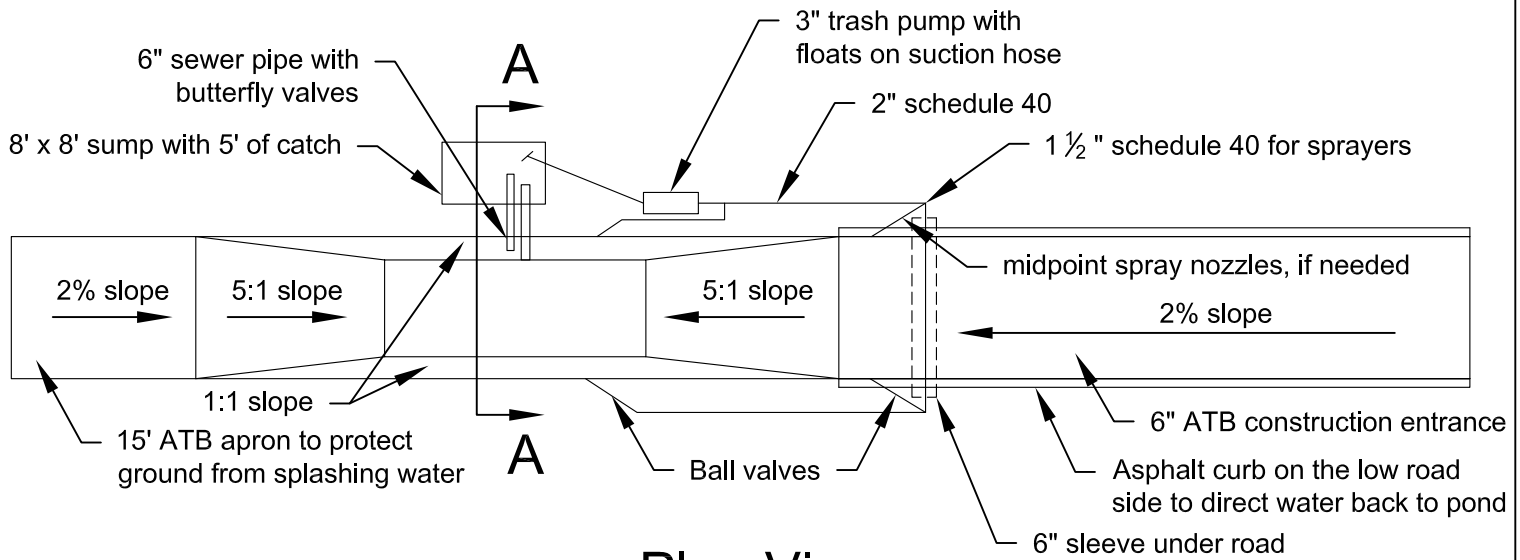

Plan View

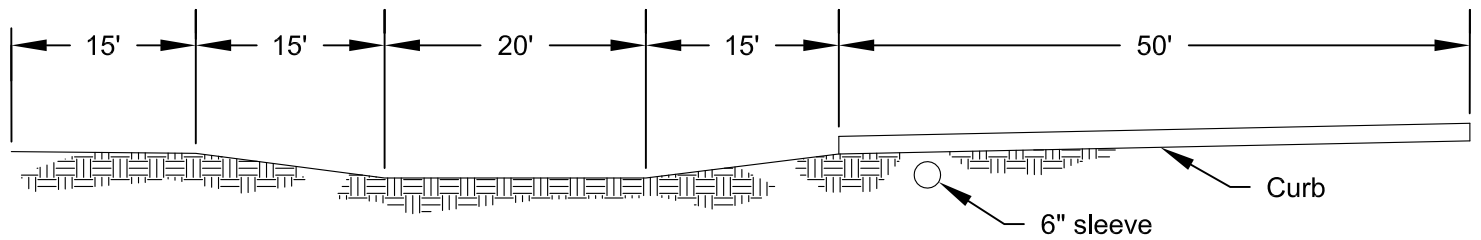

Elevation View

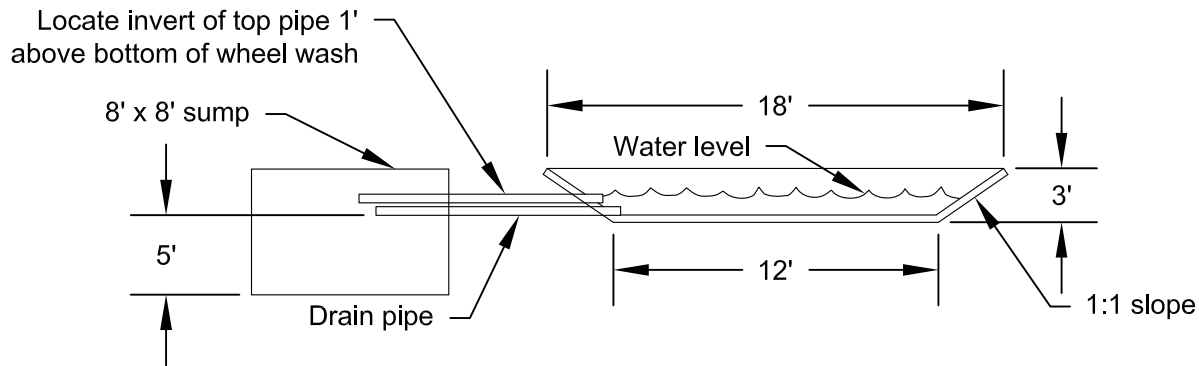

Section A-A

Notes:

1. Build 8' x 8' sump to accommodate cleaning by trackhoe.

NOT TO SCALE

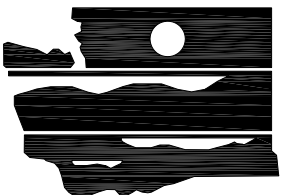

DEPARTMENT OF
ECOLOGY
State of Washington

Wheel Wash

Revised June 2016

BMP C200: Interceptor Dike and Swale

Purpose

Provide a dike of compacted soil or a swale at the top or base of a disturbed slope or along the perimeter of a disturbed construction area to convey stormwater. Use the dike and/or swale to intercept the runoff from unprotected areas and direct it to areas where erosion can be controlled. This can prevent storm runoff from entering the work area or sediment-laden runoff from leaving the construction site.

Conditions of Use

Use an interceptor dike or swale where runoff from an exposed site or disturbed slope must be conveyed to an erosion control BMP that can safely convey the stormwater.

- Locate upslope of a construction site to prevent runoff from entering the disturbed area.
- When placed horizontally across a disturbed slope, it reduces the amount and velocity of runoff flowing down the slope.
- Locate downslope to collect runoff from a disturbed area and direct it to a sediment trapping BMP (e.g. [BMP C240: Sediment Trap](#) or [BMP C241: Sediment Pond \(Temporary\)](#)).

Design and Installation Specifications

- Dike and/or swale and channel must be stabilized with temporary or permanent vegetation or other channel protection during construction.
- Steep grades require channel protection and check dams.
- Review construction for areas where overtopping may occur.
- Can be used at the top of new fill before vegetation is established.
- May be used as a permanent diversion channel to carry the runoff.
- Contributing area for an individual dike or swale should be one acre or less.
- Design the dike and/or swale to contain flows calculated by one of the following methods:
 - Single Event Hydrograph Method: The peak volumetric flow rate calculated using a 10-minute time step from a Type 1A, 10-year, 24-hour frequency storm for the worst-case land cover condition.

OR

- Continuous Simulation Method: The 10-year peak flow rate, as determined by an approved continuous runoff model with a 15-minute time step for the worst-case land cover condition. Worst-case land cover conditions (i.e. producing the most runoff) should be used for analysis. In most cases, this would be the land cover conditions just prior to final landscaping.

Interceptor Dikes

Interceptor dikes shall meet the following criteria:

- Top Width: 2 feet minimum.
- Height: 1.5 feet minimum on berm.
- Side Slope: 2H:1V or flatter.
- Grade: Depends on topography; however, dike system minimum is 0.5%, and maximum is 1%.
- Compaction: Minimum of 90% ASTM D698 standard proctor.
- Stabilization: Depends on velocity and reach. Inspect regularly to ensure stability.
- Ground Slopes less than 5%: Seed and mulch applied within 5 days of dike construction (see [BMP C121: Mulching](#)).
- Ground Slopes from 5% to 40%: Dependent on runoff velocities and dike materials. Stabilization should be done immediately using either sod or riprap, or other measures to avoid erosion.
- The upslope side of the dike shall provide positive drainage to the dike outlet. No erosion shall occur at the outlet. Provide energy dissipation measures as necessary. Sediment-laden runoff must be released through a sediment trapping BMP.
- Minimize construction traffic over temporary dikes. Use temporary cross culverts for channel crossing.
- See [Table II-4.9: Horizontal Spacing of Interceptor Dikes Along Ground Slope](#) for recommended horizontal spacing between dikes.

Table II-4.9: Horizontal Spacing of Interceptor Dikes Along Ground Slope

Average Slope	Slope Percent	Flowpath Length
20H:1V or less	3 - 5%	300 feet
(10 to 20)H:1V	5 - 10%	200 feet
(4 to 10)H:1V	10 - 25%	100 feet
(2 to 4)H:1V	25 - 50%	50 feet

Interceptor Swales

Interceptor swales shall meet the following criteria:

- Bottom Width: 2 feet minimum; the cross-section bottom shall be level.
- Depth: 1 foot minimum.
- Side Slope: 2H:1V or flatter.
- Grade: Maximum 5%, with positive drainage to a suitable outlet (such as [BMP C241: Sediment Pond \(Temporary\)](#)).
- Stabilization: Seed per [BMP C120: Temporary and Permanent Seeding](#), or [BMP C202: Riprap Channel Lining](#), 12 inches thick riprap pressed into the bank and extending at least 8 inches vertical from the bottom.

Maintenance Standards

- Inspect diversion dikes and interceptor swales once a week and after every rainfall. Immediately remove sediment from the flow area.
- Damage caused by construction traffic or other activity must be repaired before the end of each working day.
- Check outlets and make timely repairs as needed to avoid gully formation. When the area below the temporary diversion dike is permanently stabilized, remove the dike and fill and stabilize the channel to blend with the natural surface.

Washington State Department of Ecology

2024 Stormwater Management Manual for Western Washington (2024 SWMMWW)

Publication No. 24-10-013

BMP C201: Grass-Lined Channels

Purpose

To provide a channel with a vegetative lining for conveyance of runoff. The purpose of the vegetative lining is to prevent transport of sediment and erosion.

Conditions of Use

This practice applies to construction sites where concentrated runoff needs to be directed to prevent erosion or flooding.

- Use this BMP when a vegetative lining can provide sufficient stability for the channel cross section and at lower velocities of water (normally dependent on grade). This means that the channel slopes are generally less than 5% and space is available for a relatively large cross section.
- Typical uses include roadside ditches, channels at property boundaries, outlets for diversions, and other channels and drainage ditches in low areas.
- Channels that will be vegetated should be installed before major earthwork and hydroseeded with a bonded fiber matrix (BFM). The vegetation should be well established (i.e. 75% cover) before water is allowed to flow in the ditch unless [BMP C122: Nets and Blankets](#) is used to protect the channel. With channels that will have high flows, erosion control blankets should be installed over the hydroseed. If vegetation cannot be established from seed before water is allowed in the ditch, sod should be installed in the bottom of the ditch in lieu of hydromulch and blankets.

Design and Installation Specifications

See [Figure II-4.10: Typical Grass-Lined Channels](#)

Locate channels where they can conform to the topography and other features such as roads. Use natural drainage systems to the greatest extent possible

- Avoid sharp changes in alignment or bends and changes in grade.
- Do not reshape the landscape to fit the drainage channel.
- The maximum design velocity shall be based on soil conditions, type of vegetation, and method of revegetation, but at no time shall velocity exceed 5 feet/second. The channel shall not be overtopped by the peak volumetric flow rate calculated by one of the following methods:

- Single Event Hydrograph Method: The peak volumetric flow rate calculated using a 10-minute time step from a Type 1A, 10-year, 24-hour frequency storm for the worst-case land cover condition.

OR

- Continuous Simulation Method: The 10-year peak flow rate, as determined by an approved continuous runoff model with a 15-minute time step for the worst-case land cover condition.

Worst-case land cover conditions (i.e. producing the most runoff) should be used for analysis (in most cases, this would be the land cover conditions just prior to final landscaping).

- Where the grass-lined channel will also function as a permanent stormwater conveyance facility, consult the drainage conveyance requirements of the local jurisdiction.
- An established grass or vegetated lining is required before the channel can be used to convey stormwater, unless stabilized with nets or blankets (see [BMP C122: Nets and Blankets](#)).
- If design velocity of a channel to be vegetated by seeding exceeds 2 ft/sec, a temporary channel liner is required. Geotextile or special mulch protection such as fiberglass roving or straw and netting provides stability until the vegetation is fully established. See [Figure II-4.11: Temporary Channel Liners](#).
- Check dams shall be removed when the grass has matured sufficiently to protect the ditch or swale unless the slope of the swale is greater than 4%. The area beneath the check dams shall be seeded and mulched immediately after dam removal.
- If vegetation is established by sodding, the permissible velocity for established vegetation may be used and no temporary liner is needed.
- Do not subject the grass-lined channel to sedimentation from disturbed areas. Use sediment-trapping BMPs upstream of the channel.
- V-shaped grass channels generally apply where the quantity of water is small, such as in short reaches along roadsides. The V-shaped cross section is least desirable because it is difficult to stabilize the bottom where velocities may be high.
- Trapezoidal grass channels are used where runoff volumes are large and slope is low so that velocities are nonerosive to vegetated linings.

Note: it is difficult to construct small parabolic shaped channels.

- Subsurface drainage or riprap channel bottoms may be necessary on sites that are subject to prolonged wet conditions due to long duration flows or a high water table.
- Provide outlet protection at culvert ends and at channel intersections.
- Grass channels, at a minimum, should carry peak runoff for temporary construction drainage facilities from the 10-year, 24-hour storm for the worst case land cover condition without eroding. Where flood hazard exists, increase the capacity according to the potential damage.

- Grassed channel side slopes generally are constructed 3H:1V or flatter to aid in the establishment of vegetation and for maintenance.
- Construct channels a minimum of 0.2 foot larger around the periphery to allow for soil bulking during seedbed preparations and sod buildup.

Maintenance Standards

During the establishment period, check grass-lined channels after every rainfall.

- After grass is established, periodically check the channel; check it after every heavy rainfall event. Immediately make repairs.
- Check the channel outlet and all road crossings for bank stability and evidence of piping or scour holes.
- Remove all significant sediment accumulations to maintain the designed carrying capacity. Keep the grass in a healthy, vigorous condition at all times, since it is the primary erosion protection for the channel.

BMP C202: Riprap Channel Lining

Purpose

To protect channels from erosion by providing a channel liner using riprap.

Conditions of Use

Use this BMP when natural soils or vegetated stabilized soils in a channel are not adequate to prevent channel erosion.

Use this BMP when a permanent ditch or pipe system is to be installed and a temporary measure is needed.

An alternative to riprap channel lining is [BMP C122: Nets and Blankets](#).

The Federal Highway Administration recommends not using geotextile liners whenever the slope exceeds 10% or the shear stress exceeds 8 lbs/ft².

Design and Installation Specifications

- Since riprap is typically used where erosion potential is high, construction must be sequenced so that the riprap is put in place with the minimum possible delay.
- Disturb areas awaiting riprap only when final preparation and placement of the riprap can follow immediately behind the initial disturbance. Where riprap is used for outlet protection, the riprap should be placed before or in conjunction with the construction of the pipe or channel so that it is in place when the pipe or channel begins to operate.
- The designer, after determining the riprap size that will be stable under the flow conditions, shall consider that size to be a minimum size and then, based on riprap gradations actually available in the area, select the size or sizes that equal or exceed the minimum size. The possibility of drainage structure damage by others shall be considered in selecting a riprap size, especially if there is nearby water or a gully in which to toss the stones.
- Stone for riprap shall consist of field stone or quarry stone that is approximately rectangular in shape. The stone shall be hard and angular and of such quality that it will not disintegrate on exposure to water or weathering and it shall be suitable in all respects for the purpose intended. See Section 9-13 of WSDOT's *Standard Specifications for Road, Bridge, and Municipal Construction* ([WSDOT, 2016](#)).

- A lining of engineering filter fabric (geotextile) shall be placed between the riprap and the underlying soil surface to prevent soil movement into or through the riprap. The geotextile should be keyed in at the top of the bank.
- Filter fabric shall not be used on slopes greater than 1.5H:1V as slippage may occur. It should be used in conjunction with a layer of coarse aggregate (granular filter blanket) when the riprap to be placed is 12 inches and larger.

Maintenance Standards

Replace the riprap as needed.

Washington State Department of Ecology

2024 Stormwater Management Manual for Western Washington (2024 SWMMWW)

Publication No. 24-10-013

BMP C203: Water Bars

Purpose

A water bar is a small ditch or ridge of material that is constructed diagonally across a road or right-of-way to divert stormwater runoff from the road surface, wheel tracks, or a shallow road ditch. See [Figure II-4.12: Water Bar](#).

Conditions of Use

Clearing right-of-way and construction of access for power lines, pipelines, and other similar installations often require long narrow rights-of-ways over sloping terrain. Disturbance and compaction promotes gully formation in these cleared strips by increasing the volume and velocity of runoff. Gully formation may be especially severe in tire tracks and ruts. To prevent gullying, runoff can often be diverted across the width of the right-of-way to undisturbed areas by using small predesigned diversions.

Give special consideration to each individual outlet area, as well as to the cumulative effect of added diversions. Use gravel to stabilize the diversion where significant vehicular traffic is anticipated.

Design and Installation Specifications

- Height: 8-inches minimum, measured from the channel bottom to the ridge top.
- Side slope of channel: 2H:1V maximum; 3H:1V or flatter when vehicles will cross.
- Top width of ridge: 6-inches minimum.
- Locate water bars to use natural drainage systems and to discharge into well vegetated stable areas.
- See [Table II-4.10: Water Bar Spacing Guidelines](#):

Table II-4.10: Water Bar Spacing Guidelines

Slope Along Road (%)	Spacing (ft)
< 5	125
5 - 10	100

Slope Along Road (%)	Spacing (ft)
10 - 20	75
20 - 35	50
> 35	Use rock lined ditch

- Grade of water bar and angle: Select an angle that results in a ditch slope less than 2%.
- Install the water bar as soon as the clearing and grading is complete. When utilities are being installed, reconstruct the water bar as construction is complete in each section.
- Compact the water bar ridge.
- Stabilize, seed, and mulch the portions that are not subject to traffic. Gravel the areas crossed by vehicles.
- Note that [BMP C208: Triangular Silt Dike \(TSD\)](#) can be used to create the ridge for the water bar.

Maintenance Standards

Periodically inspect water bars for wear, and after every heavy rainfall for wear and/or erosion damage.

- Immediately remove sediment from the flow area and repair the dike.
- Check outlet areas and make timely repairs as needed.
- When permanent road drainage is established and the area above the temporary water bar is permanently stabilized, remove the dikes and fill the channel to blend with the natural ground, and appropriately stabilize the disturbed area.

BMP C204: Pipe Slope Drains

Purpose

The purpose of pipe slope drains is to prevent gullies, channel erosion, and saturation of slide-prone soils by using a pipe to convey stormwater away from or over bare soil.

Conditions of Use

Pipe slope drains should be used when a temporary or permanent stormwater conveyance is needed to move water down a steep slope to avoid erosion.

Pipe slope drains should be used at bridge ends to collect runoff and convey it to the base of the fill slopes along the bridge approaches. Another use on road projects is to collect runoff from pavement in a pipe slope drain and convey it away from side slopes.

Temporary installations of pipe slope drains can be useful because there is generally a time lag between having the first lift of asphalt installed and the curbs, gutters, and permanent drainage installed. Used in conjunction with sand bags, or other temporary diversion devices, these will prevent massive amounts of sediment from leaving a project.

Pipe slope drains can serve the following purposes:

- Connection to new catch basins and temporarily use until permanent piping is installed.
- Drainage of water collected from aquifers exposed on cut slopes and conveyance of water to the base of the slope.
- Collection of clean runoff from plastic sheeting and routing the runoff away from exposed soil.
- Installation in conjunction with silt fence to drain collected water to a controlled area.
- Diversion of small seasonal streams away from construction. They have been used successfully on culvert replacement and extension jobs. Large flex pipe can be used on larger streams during culvert removal, repair, or replacement.
- Connection to existing downspouts and roof drains and diversion of water away from work areas during building renovation, demolition, and construction projects.

There are several commercially available collectors that attach to the pipe inlet and help prevent erosion at the inlet.

Design and Installation Specifications

- See [Figure II-4.13: Pipe Slope Drain](#).
- Size the pipe to convey the projected flow.

The capacity for temporary pipe slope drains shall be sufficient to handle flows calculated by one of the following methods:

- Single Event Hydrograph Method: The peak volumetric flow rate calculated using a 10-minute time step from a Type 1A, 10-year, 24-hour frequency storm for the worst-case land cover condition.

OR

- Continuous Simulation Method: The 10-year peak flow rate, as determined by an approved continuous runoff model with a 15-minute time step for the worst-case land cover condition.

Consult local drainage requirements for sizing permanent pipe slope drains.

Worst-case land cover conditions (i.e. producing the most runoff) should be used for analysis (in most cases, this would be the land cover conditions just prior to final landscaping).

- Use care in clearing vegetated slopes for installation.
- Re-establish cover immediately on areas disturbed by installation.
- Use temporary drains on new cut or fill slopes.
- Use [BMP C200: Interceptor Dike and Swale](#) to collect water at the top of the slope.
- Ensure that the entrance area is stable and large enough to direct flow into the pipe.
- Piping of water through the berm at the entrance area is a common failure mode.
- The entrance shall consist of a standard flared end section for culverts 12 inches and larger with a minimum 6-inch metal toe plate to prevent runoff from undercutting the pipe inlet. The slope of the entrance shall be at least 3%. Sand bags may also be used at pipe entrances as a temporary measure.
- The soil around and under the pipe and entrance section shall be thoroughly compacted to prevent undercutting.
- The flared inlet section shall be securely connected to the slope drain and have watertight connecting bands.
- Slope drain sections shall be securely fastened together, be fused, or have gasketed watertight fittings, and shall be securely anchored into the soil.
- Thrust blocks should be installed anytime 90 degree bends are used. Depending on size of pipe and flow, these can be constructed with sand bags, straw bales staked in place, "T" posts and wire, or ecology blocks.

- The pipe needs to be secured along its full length to prevent movement. This can be done with steel “T” posts and wire. Install a post on each side of the pipe and wire the pipe to the posts. This should be done every 10 to 20 feet of pipe length or so, depending on the size of the pipe and quantity of water to divert.
- [BMP C200: Interceptor Dike and Swale](#) shall be used to direct runoff into a pipe slope drain. The height of the dike shall be at least 1 foot higher at all points than the top of the inlet pipe.
- The area below the outlet must be stabilized. See [BMP C209: Outlet Protection](#).
- If the pipe slope drain is conveying sediment-laden water, direct all flows into a sediment trapping BMP.
- Materials specifications for any permanent piped system shall be set by the local jurisdiction.

Maintenance Standards

Check inlet and outlet points regularly, especially after storms.

- The inlet should be free of undercutting, and no water should be going around the point of entry. If there are problems, the headwall should be reinforced with compacted earth or sand bags.
- The outlet point should be free of erosion and installed with appropriate outlet protection.

For permanent installations, inspect the pipe periodically for vandalism and physical distress such as slides and wind-throw. Clean the pipe and outlet structure at the completion of construction.

Normally the pipe slope is so steep that clogging is not a problem with smooth wall pipe, however, debris may become lodged in the pipe.

BMP C205: Subsurface Drains

Purpose

The purpose of subsurface drains is to intercept, collect, and convey groundwater to a satisfactory outlet, using a perforated pipe or other conduit below the ground surface. Subsurface drains are also known as “french drains”. The perforated pipe provides a dewatering mechanism to drain excessively wet soils, which provides a stable base for construction, improves stability of structures with shallow foundations, and/or reduces hydrostatic pressure to improve slope stability.

Conditions of Use

Use subsurface drains when excessive water must be removed from the soil. The soil permeability, depth to water table, and impervious layers are all factors that may govern the use of subsurface drains.

Design and Installation Specifications

Subsurface Drain Type: Relief Drains

- Relief drains are used to lower the water table in large, relatively flat areas, to improve the growth of vegetation or to remove surface water.
- Relief drains are installed along a slope and drain in the direction of the slope.
- Relief drains can be installed in a grid pattern, a herringbone pattern, or a random pattern.

Subsurface Drain Type: Interceptor Drains

- Interceptor drains are used to remove excess groundwater from a slope, stabilize steep slopes, and lower the water table immediately below a slope to prevent the soil from becoming saturated.
- Interceptor drains are installed perpendicular to a slope and drain to the side of the slope.
- Interceptor drains usually consist of a single pipe or series of single pipes instead of a patterned layout.

Subsurface Drain Depth and Spacing

- The depth of a subsurface drain is determined primarily by the depth to which the water table is to be lowered or the depth to a confining layer. For practical reasons, the maximum depth is usually limited to 6

feet, with a minimum cover of 2 feet to protect the conduit.

- The soil should have depth and sufficient permeability to permit installation of an effective drainage system at a depth of 2 to 6 feet.

Subsurface Drain Sizing and Placement

- The quantity and quality of discharge needs to be accounted for in the receiving stream (additional detention may be required).
- The size of a subsurface drain is determined by first calculating the maximum rate of groundwater flow to be intercepted, and then choosing a subsurface drain pipe (or pipes) with enough capacity to convey that flow. Therefore, it is good practice to make complete subsurface investigations, including hydraulic conductivity of the soil, before designing a subsurface drainage system.
- Size subsurface drains to carry the required capacity without pressure flow. Minimum diameter for a subsurface drain is 4 inches.
- The minimum velocity in the pipe required to prevent silting is 1.4 ft/sec. Grade the subsurface drain to achieve this velocity at a minimum. The maximum allowable velocity using a sand-gravel filter or envelope is 9 ft/sec.
- Filter material and fabric shall be used around all drains for proper bedding and filtration of fine materials. Envelopes and filters should surround the drain to a minimum thickness of 3 inches.
- The trench shall be constructed on a continuous grade with no reverse grades or low spots.
- Soft or yielding soils under the subsurface drain shall be stabilized with gravel or other suitable material.
- Backfilling shall be done immediately after placement of the pipe. No sections of pipe shall remain uncovered overnight or during a rainstorm. Backfill material shall be placed in the trench in such a manner that the drain pipe is not displaced or damaged.
- Do not install permanent drains near trees to avoid the tree roots that tend to clog the line. Use solid pipe with watertight connections where it is necessary to pass a subsurface drainage system through a stand of trees.

Subsurface Drain Outlets

- An adequate outlet for the subsurface drain must be available either by gravity or by pumping.
- The outlet of the subsurface drain shall empty into a sediment trapping BMP through a catch basin. If free of sediment, it can then empty into a receiving channel, swale, or stable vegetated area adequately protected from erosion and undermining.
- Ensure that the outlet of a subsurface drain empties into a channel or other watercourse above the normal water level.
- Secure an animal guard to the outlet end of the pipe to keep out rodents.

- Use outlet pipe of corrugated metal, cast iron, or heavy-duty plastic without perforations and at least 10 feet long. Do not use an envelope or filter material around the outlet pipe, and bury at least two-thirds of the pipe length.
- When outlet velocities exceed those allowable for the receiving stream, outlet protection must be provided.

Maintenance Standards

Subsurface drains shall be checked periodically to ensure that they are free-flowing and have not become clogged with sediment or roots.

- The outlet shall be kept clean and free of debris.
- Surface inlets shall be kept open and free of sediment and other debris.
- Trees located too close to a subsurface drain often clog the system with their roots. If a drain becomes clogged, relocate the drain or remove the trees as a last resort. Drain placement should be planned to minimize this problem.
- Where drains are crossed by heavy vehicles, the line shall be checked to ensure that it is not crushed.

Washington State Department of Ecology

2024 Stormwater Management Manual for Western Washington (2024 SWMMWW)

Publication No. 24-10-013

BMP C206: Level Spreader

Purpose

The purpose of a level spreader as a Construction Stormwater BMP is to provide a temporary outlet for dikes and diversions and convert concentrated runoff to sheet flow prior to releasing it to stabilized areas.

Conditions of Use

Use level spreaders when a concentrated flow of water needs to be dispersed over a large area with existing stable vegetation.

Use only where the slopes are gentle, the water volume is relatively low, and the soil will adsorb most of the low flow events.

Items to consider are:

- What is the risk of erosion or damage if the flow becomes concentrated?
- Is an easement required if the flow is discharged to adjoining property?

Design and Installation Specifications

- Use above undisturbed areas that are stabilized by existing vegetation.
- Discharge area below the outlet must be uniform with a slope flatter than 5H:1V.
- Do not allow any low points in the level spreader. If the level spreader has any low points, flow will concentrate, create channels and may cause erosion.
- Ensure the outlet is level in a stable, undisturbed soil profile (not on fill).
- The runoff shall not re-concentrate on site after release from the level spreader unless it is intercepted by another downstream measure.
- The grade of the channel for the last 20 feet of the dike or interceptor entering the level spreader shall be less than or equal to 1%. The grade of the level spreader shall be 0% to ensure uniform spreading of runoff.
- A 6-inch high gravel berm placed across the level lip shall consist of washed crushed rock, 2- to 4-inch or 3/4-inch to 1½-inch size.

- The spreader length must handle the peak volumetric flow rate calculated using a 10-minute time step from a Type 1A, 10-year, 24-hour design storm.

The length of the spreader shall be a minimum of 15 feet for 0.1 cfs and shall increase by 10 feet for each 0.1 cfs thereafter to a maximum of 0.5 cfs per spreader. Use multiple spreaders for higher flows.

- The width of the approach to the spreader should be at least 6 feet.
- The depth of the spreader as measured from the lip should be at least 6 inches and it should be uniform across the entire length.
- Level spreaders shall be set back from the property line unless there is an easement for flow.
- Materials that can be used for level spreaders include sand bags, lumber, logs, concrete, pipe, and capped perforated pipe. To function properly, the material needs to be installed level and on contour.
- See [Figure II-4.14: Cross Section of Level Spreader](#) and [Figure II-4.15: Detail of Level Spreader](#).

Maintenance Standards

The level spreader should be inspected during and after runoff events to ensure that it is functioning correctly.

- The contractor should avoid the placement of any material on the level spreader, and should prevent construction traffic from crossing over the level spreader.
- If the level spreader is damaged by construction traffic, it shall be immediately repaired.

BMP C207: Check Dams

Purpose

Construction of check dams across a swale or ditch reduces the velocity of concentrated flow and dissipates energy at the check dam.

Conditions of Use

Use check dams where temporary or permanent channels are not yet vegetated, channel lining is infeasible, and/or velocity checks are required.

- Check dams may not be placed in streams unless approved by the State Department of Fish and Wildlife.
- Check dams may not be placed in wetlands without approval from a permitting agency.
- Do not place check dams below the expected backwater from any salmonid bearing water between October 1 and May 31 to ensure that there is no loss of high flow refuge habitat for overwintering juvenile salmonids and emergent salmonid fry.

Design and Installation Specifications

- Construct rock check dams from appropriately sized rock. The rock used must be large enough to stay in place given the expected design flow through the channel. The rock must be placed by hand or by mechanical means (do not dump the rock to form the dam) to achieve complete coverage of the ditch or swale and to ensure that the center of the dam is lower than the edges.
- Check dams may also be constructed of either rock or pea-gravel filled bags. Numerous new products are also available for this purpose. They tend to be re-usable, quick and easy to install, effective, and cost efficient.
- Place check dams perpendicular to the flow of water.
- The check dam should form a triangle when viewed from the side. This prevents undercutting as water flows over the face of the check dam rather than falling directly onto the ditch bottom.
- Before installing check dams, impound and bypass upstream water flow away from the work area. Options for bypassing include pumps, siphons, or temporary channels.
- Check dams combined with sumps work more effectively at slowing flow and retaining sediment than a check dam alone. A deep sump should be provided immediately upstream of the check dam.

- In some cases, if carefully located and designed, check dams can remain as permanent installations with very minor regrading. They may be left as either spillways, in which case accumulated sediment would be graded and seeded, or as check dams to prevent further sediment from leaving the site.
- The maximum spacing between check dams shall be such that the downstream toe of the upstream dam is at the same elevation as the top of the downstream dam.
- Keep the maximum height at 2 feet at the center of the check dam.
- Keep the center of the check dam at least 12 inches lower than the outer edges at natural ground elevation.
- Keep the side slopes of the check dam at 2H:1V or flatter.
- Key the stone into the ditch banks and extend it beyond the abutments a minimum of 18 inches to avoid washouts from overflow around the dam.
- Use filter fabric foundation under a rock or sand bag check dam. If a blanket ditch liner is used, filter fabric is not necessary. A piece of organic or synthetic blanket cut to fit will also work for this purpose.
- In the case of grass-lined ditches and swales, all check dams and accumulated sediment shall be removed when the grass has matured sufficiently to protect the ditch or swale - unless the slope of the swale is greater than 4%. The area beneath the check dams shall be seeded and mulched immediately after dam removal.
- Ensure that channel appurtenances, such as culvert entrances below check dams, are not subject to damage or blockage from displaced stones.
- See [Figure II-4.16: Rock Check Dam](#).

Maintenance Standards

Check dams shall be monitored for performance and sediment accumulation during and after each rainfall that produces runoff. Sediment shall be removed when it reaches one half the sump depth.

- Anticipate submergence and deposition above the check dam and erosion from high flows around the edges of the dam.
- If significant erosion occurs between dams, install a protective riprap liner in that portion of the channel. See [BMP C202: Riprap Channel Lining](#).

Approved as Functionally Equivalent

Ecology has approved products as able to meet the requirements of this BMP. The products did not pass through the Technology Assessment Protocol – Ecology (TAPE) process. Local jurisdictions may choose not to accept these products, or may require additional testing prior to consideration for local use. Products that Ecology has approved as functionally equivalent are available for review on Ecology’s website at:

BMP C209: Outlet Protection

Purpose

Outlet protection prevents scour at conveyance outlets and minimizes the potential for downstream erosion by reducing the velocity of concentrated stormwater flows.

Conditions of Use

Use outlet protection at the outlets of all ponds, pipes, ditches, or other conveyances that discharge to a natural or constructed drainage feature such as a stream, wetland, lake, or ditch.

Design and Installation Specifications

- The receiving channel at the outlet of a pipe shall be protected from erosion by lining a minimum of 6 feet downstream and extending up the channel sides a minimum of 1 foot above the maximum tailwater elevation, or 1 foot above the crown, whichever is higher. For pipes larger than 18 inches in diameter, the outlet protection lining of the channel shall be four times the diameter of the outlet pipe.
- Standard wingwalls, tapered outlets, and paved channels should also be considered when appropriate for permanent culvert outlet protection ([WSDOT, 2015](#)).
- [BMP C122: Nets and Blankets](#) or [BMP C202: Riprap Channel Lining](#) provide suitable options for lining materials.
- With low flows, [BMP C201: Grass-Lined Channels](#) can be an effective alternative for lining material.
- The following guidelines shall be used for outlet protection with riprap:
 - If the discharge velocity at the outlet is less than 5 fps, use 2-inch to 8-inch riprap. Minimum thickness is 1 foot.
 - For a 5 to 10 fps discharge velocity at the outlet, use 24-inch to 48-inch riprap. Minimum thickness is 2 feet.
 - For outlets at the base of steep slope pipes (pipe slope greater than 10 percent), use an engineered energy dissipator.
 - Filter fabric or erosion control blankets should always be used under riprap to prevent scour and channel erosion. See [BMP C122: Nets and Blankets](#).

- Bank stabilization, bioengineering, and habitat features may be required for disturbed areas. This work may require a Hydraulic Project Approval (HPA) from the Washington State Department of Fish and Wildlife. See [I-2.14 Hydraulic Project Approvals](#).

Maintenance Standards

- Inspect and repair as needed.
- Add rock as needed to maintain the intended function.
- Clean energy dissipator if sediment builds up.

Washington State Department of Ecology

2024 Stormwater Management Manual for Western Washington (2024 SWMMWW)

Publication No. 24-10-013

BMP C220: Inlet Protection

Purpose

Inlet protection prevents coarse sediment from entering drainage systems prior to permanent stabilization of the disturbed area.

Conditions of Use

Use inlet protection at inlets that are operational before permanent stabilization of the disturbed areas that contribute runoff to the inlet. Provide protection for all storm drain inlets downslope and within 500 feet of a disturbed or construction area, unless those inlets are preceded by a sediment trapping BMP.

Also consider inlet protection for lawn and yard drains on new home construction. These small and numerous drains coupled with lack of gutters can add significant amounts of sediment into the roof drain system. If possible, delay installing lawn and yard drains until just before landscaping, or cap these drains to prevent sediment from entering the system until completion of landscaping. Provide 18-inches of sod around each finished lawn and yard drain.

[Table II-4.11: Storm Drain Inlet Protection](#) lists several options for inlet protection. All of the methods for inlet protection tend to plug and require a high frequency of maintenance. Limit contributing drainage areas for an individual inlet to one acre or less. If possible, provide emergency overflows with additional end-of-pipe treatment where stormwater ponding would cause a hazard.

Table II-4.11: Storm Drain Inlet Protection

Type of Inlet Protection	Emergency Overflow	Applicable for Paved / Earthen Surfaces	Conditions of Use
Drop Inlet Protection			
Excavated drop inlet protection	Yes, temporary flooding may occur	Earthen	Applicable for heavy flows. Easy to maintain. Large area requirement: 30'x30'/acre
Block and gravel drop inlet protection	Yes	Paved or Earthen	Applicable for heavy concentrated flows. Will not pond.
Gravel and wire drop inlet protection	No	Paved or Earthen	Applicable for heavy concentrated flows. Will pond. Can withstand traffic.
Catch basin filters	Yes	Paved or Earthen	Frequent maintenance required.

Type of Inlet Protection	Emergency Overflow	Applicable for Paved / Earthen Surfaces	Conditions of Use
Curb Inlet Protection			
Curb inlet protection with wooden weir	Small capacity overflow	Paved	Used for sturdy, more compact installation.
Block and gravel curb inlet protection	Yes	Paved	Sturdy, but limited filtration.
Culvert Inlet Protection			
Culvert inlet sediment trap	N/A	N/A	18 month expected life.

Design and Installation Specifications

Excavated Drop Inlet Protection

Excavated drop inlet protection consists of an excavated impoundment around the storm drain inlet. Sediment settles out of the stormwater prior to entering the storm drain. Design and installation specifications for excavated drop inlet protection include:

- Provide a depth of 1 to 2 feet as measured from the crest of the inlet structure.
- Side slopes of excavation should be no steeper than 2H:1V.
- Minimum volume of excavation is 35 cubic yards.
- Shape the excavation to fit the site, with the longest dimension oriented toward the longest inflow area.
- Install provisions for draining to prevent standing water.
- Clear the area of all debris.
- Grade the approach to the inlet uniformly.
- Drill weep holes into the side of the inlet.
- Protect weep holes with screen wire and washed aggregate.
- Seal weep holes when removing structure and stabilizing area.
- Build a temporary dike, if necessary, to the down slope side of the structure to prevent bypass flow.

Block and Gravel Filter

A block and gravel filter is a barrier formed around the inlet with standard concrete blocks and gravel. See [Figure II-4.17: Block and Gravel Filter](#). Design and installation specifications for block and gravel filters include:

- Provide a height of 1 to 2 feet above the inlet.
- Recess the first row of blocks 2-inches into the ground for stability.
- Support subsequent courses by placing a pressure treated wood (2x4) through the block opening.
- Do not use mortar.
- Lay some blocks in the bottom row on their side to allow for dewatering the pool.
- Place hardware cloth or comparable wire mesh with 0.5-inch openings over all block openings.
- Place gravel to just below the top of blocks on slopes of 2H:1V or flatter.
- An alternative design is a gravel berm surrounding the inlet, as follows:
 - Provide a slope of 3H:1V on the upstream side of the berm.
 - Provide a slope of 2H:1V on the downstream side of the berm.
 - Provide a 1-foot wide level rock area between the gravel berm and the inlet.
 - Use rocks 3 inches in diameter or larger on the upstream slope of the berm.
 - Use gravel 0.5 to 0.75 inch at a minimum thickness of 1-foot on the downstream slope of the berm.

Figure II-4.17: Block and Gravel Filter

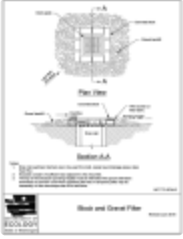

[Download PDF](#)

Gravel and Wire Mesh Filter

Gravel and wire mesh filters are gravel barriers placed over the top of the inlet. This method does not provide an overflow. Design and installation specifications for gravel and wire mesh filters include:

- Use a hardware cloth or comparable wire mesh with 0.5 inch openings.
 - Place wire mesh over the drop inlet so that the wire extends a minimum of 1-foot beyond each side of the inlet structure.
 - Overlap the strips if more than one strip of mesh is necessary.
- Place coarse aggregate over the wire mesh.
 - Provide at least a 12-inch depth of aggregate over the entire inlet opening and extend at least 18-inches on all sides.

Catch Basin Filters

Catch basin filters are designed by manufacturers for construction sites. The limited sediment storage capacity increases the amount of inspection and maintenance required, which may be daily for heavy sediment loads. To reduce maintenance requirements, combine a catch basin filter with another type of inlet protection. This type of inlet protection provides flow bypass without overflow and therefore may be a better method for inlets located along active rights-of-way. Design and installation specifications for catch basin filters include:

- Provides 5 cubic feet of storage.
- Requires dewatering provisions.
- Provides a high-flow bypass that will not clog under normal use at a construction site.
- Insert the catch basin filter in the catch basin just below the grating.

Curb Inlet Protection with Wooden Weir

Curb inlet protection with wooden weir is an option that consists of a barrier formed around a curb inlet with a wooden frame and gravel. Design and installation specifications for curb inlet protection with wooden weirs include:

- Use wire mesh with 0.5 inch openings.
- Use extra strength filter cloth.
- Construct a frame.
- Attach the wire and filter fabric to the frame.
- Pile coarse washed aggregate against the wire and fabric.
- Place weight on the frame anchors.

Block and Gravel Curb Inlet Protection

Block and gravel curb inlet protection is a barrier formed around a curb inlet with concrete blocks and gravel. See [Figure II-4.18: Block and Gravel Curb Inlet Protection](#). Design and installation specifications for block and gravel curb inlet protection include:

- Use wire mesh with 0.5 inch openings.
- Place two concrete blocks on their sides abutting the curb at either side of the inlet opening. These are spacer blocks.
- Place a 2x4 stud through the outer holes of each spacer block to align the front blocks.
- Place blocks on their sides across the front of the inlet and abutting the spacer blocks.
- Place wire mesh over the outside vertical face.
- Pile coarse aggregate against the wire to the top of the barrier.

Figure II-4.18: Block and Gravel Curb Inlet Protection

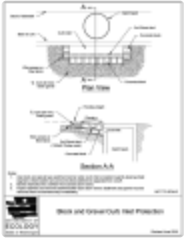

[Download PDF](#)

Curb and Gutter Sediment Barrier

A curb and gutter sediment barrier is a sandbag or rock berm (riprap and aggregate) 3 feet high and 3 feet wide in a horseshoe shape. See [Figure II-4.19: Curb and Gutter Barrier](#). Design and installation specifications for curb and gutter sediment barriers include:

- Construct a horseshoe shaped berm, faced with coarse aggregate if using riprap, 3 feet high and 3 feet wide, at least 2 feet from the inlet.
- Construct a horseshoe shaped sedimentation trap on the upstream side of the berm. Size the trap to sediment trap standards for protecting a culvert inlet.

Figure II-4.19: Curb and Gutter Barrier

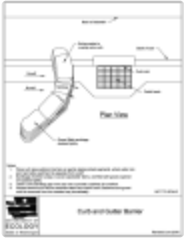

[Download PDF](#)

Maintenance Standards

- Inspect all forms of inlet protection frequently, especially after storm events. Clean and replace clogged catch basin filters. For rock and gravel filters, pull away the rocks from the inlet and clean or replace. An alternative approach would be to use the clogged rock as fill and put fresh rock around the inlet.
- Do not wash sediment into storm drains while cleaning. Spread all excavated material evenly over the surrounding land area or stockpile and stabilize as appropriate.

Approved as Functionally Equivalent

Ecology has approved products as able to meet the requirements of this BMP. The products did not pass through the Technology Assessment Protocol – Ecology (TAPE) process. Local jurisdictions may choose not to accept these products, or may require additional testing prior to consideration for local use. Products that Ecology has approved as functionally equivalent are available for review on Ecology’s website at:

<https://ecology.wa.gov/Regulations-Permits/Guidance-technical-assistance/Stormwater-permittee-guidance-resources/Emerging-stormwater-treatment-technologies>

Washington State Department of Ecology

2024 Stormwater Management Manual for Western Washington (2024 SWMMWW)

Publication No. 24-10-013

BMP C231: Brush Barrier

Purpose

The purpose of brush barriers is to reduce the transport of coarse sediment from a construction site by providing a temporary physical barrier to sediment and reducing the runoff velocities of overland flow.

Conditions of Use

- Brush barriers may be used downslope of disturbed areas that are less than one-quarter acre.
- Brush barriers are not intended to treat concentrated flows, nor are they intended to treat substantial amounts of overland flow. Any concentrated flows must be directed to a sediment trapping BMP. The only circumstance in which overland flow can be treated solely by a brush barrier, rather than by a sediment trapping BMP, is when the area draining to the barrier is small.
- Brush barriers should only be installed on contours.

Design and Installation Specifications

- Height: 2 feet (minimum) to 5 feet (maximum).
- Width: 5 feet at base (minimum) to 15 feet (maximum).
- Filter fabric (geotextile) may be anchored over the brush berm to enhance the filtration ability of the barrier. Ten-ounce burlap is an adequate alternative to filter fabric.
- Chipped site vegetation, composted mulch, or wood-based mulch (hog fuel) are acceptable materials to construct brush barriers.
- A 100% biodegradable installation can be constructed using 10-ounce burlap held in place by wooden stakes.
- [Figure II-4.20: Brush Barrier](#) depicts a typical brush barrier.

Maintenance Standards

- There shall be no signs of erosion or concentrated runoff under or around the barrier. If concentrated flows are bypassing the barrier, it must be expanded or augmented by toed-in filter fabric.
- The dimensions of the barrier must be maintained.

Figure II-4.20: Brush Barrier

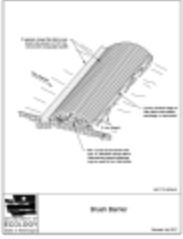

[Download PDF](#)

Washington State Department of Ecology

2024 Stormwater Management Manual for Western Washington (2024 SWMMWW)

Publication No. 24-10-013

BMP C232: Gravel Filter Berm

Purpose

A gravel filter berm retains sediment by filtering runoff through a berm of gravel or crushed rock.

Conditions of Use

Use a gravel filter berm where a temporary measure is needed to retain sediment from construction sites.

Do not place gravel filter berms in traffic areas; gravel filter berms are not intended to be driven over.

Place gravel filter berms perpendicular to the flow of runoff, such that the runoff will filter through the berm prior to leaving the site.

Design and Installation Specifications

- Berm material shall be 0.75 to 3 inches in size, washed well-graded gravel or crushed rock with less than 5% fines. Do not use crushed concrete.
- Spacing of berms:
 - Every 300 feet on slopes less than 5%
 - Every 200 feet on slopes between 5% and 10%
 - Every 100 feet on slopes greater than 10%
- Berm dimensions:
 - 1 foot high with 3H:1V side slopes
 - 8 linear feet per 1 cfs runoff based on the 10-year, 24-hour design storm
- See [Figure II-4.21: Gravel Filter Berm](#) for a photo of a gravel filter berm application.

Maintenance Standards

Regular inspection is required. Sediment shall be removed and filter material replaced as needed.

BMP C233: Silt Fence

Purpose

Silt fence reduces the transport of coarse sediment from a construction site by providing a temporary physical barrier to sediment and reducing the runoff velocities of overland flow.

Conditions of Use

Silt fence may be used downslope of all disturbed areas.

- Silt fence shall prevent sediment carried by runoff from going beneath, through, or over the top of the silt fence, but shall allow the water to pass through the fence.
- Silt fence is not intended to treat concentrated flows, nor is it intended to treat substantial amounts of overland flow. Convey any concentrated flows through the drainage system to a sediment trapping BMP.
- Do not construct silt fences in streams or use in V-shaped ditches. Silt fences do not provide an adequate method of silt control for anything deeper than sheet or overland flow.

Figure II-4.22: Silt Fence



[Download PDF](#)

Design and Installation Specifications

- Use in combination with other construction stormwater BMPs.
- Maximum slope steepness (perpendicular to the silt fence line) 1H:1V.
- Maximum sheet or overland flow path length to the silt fence of 100 feet.
- Do not allow flows greater than 0.5 cfs.
- Use geotextile fabric that meets the following standards. All geotextile properties listed below are minimum average roll values (i.e. the test result for any sampled roll in a lot shall meet or exceed the values shown in [Table II-4.12: Geotextile Fabric Standards for Silt Fence](#)):

Table II-4.12: Geotextile Fabric Standards for Silt Fence

Geotextile Property	Minimum Average Roll Value
Polymeric Mesh AOS (ASTM D4751)	0.60 mm maximum for slit film woven (#30 sieve). 0.30 mm maximum for all other geotextile types (#50 sieve). 0.15 mm minimum for all fabric types (#100 sieve).
Water Permittivity (ASTM D4491)	0.02 sec ⁻¹ minimum
Grab Tensile Strength (ASTM D4632)	180 lbs minimum for extra strength fabric. 100 lbs minimum for standard strength fabric.
Grab Tensile Strength (ASTM D4632)	30% maximum
Ultraviolet Resistance (ASTM D4355)	70% minimum

- Support standard strength geotextiles with wire mesh, chicken wire, 2-inch x 2-inch wire, safety fence, or jute mesh to increase the strength of the geotextile. Silt fence materials are available that have synthetic mesh backing attached.

- Silt fence material shall contain ultraviolet ray inhibitors and stabilizers to provide a minimum of 6 months of expected usable construction life at a temperature range of 0°F to 120°F.
- 100% biodegradable silt fence is available that is strong, long lasting, and can be left in place after the project is completed, if permitted by the local jurisdiction.
- Refer to [Figure II-4.22: Silt Fence](#) for standard silt fence details. Include the following Standard Notes for silt fence on construction plans and specifications:
 1. The Contractor shall install and maintain temporary silt fences at the locations shown in the Plans.
 2. Construct silt fences in areas of clearing, grading, or drainage prior to starting those activities.
 3. The silt fence shall have a 2-foot min. and a 2.5-foot max. height above the original ground surface.
 4. The geotextile fabric shall be sewn together at the point of manufacture to form fabric lengths as required. Locate all sewn seams at support posts. Alternatively, two sections of silt fence can be overlapped, provided that the overlap is long enough and that the adjacent silt fence sections are close enough together to prevent silt laden water from escaping through the fence at the overlap.
 5. Attach the geotextile fabric on the up-slope side of the posts and secure with staples, wire, or in accordance with the manufacturer's recommendations. Attach the geotextile fabric to the posts in a manner that reduces the potential for tearing.
 6. Support the geotextile fabric with wire or plastic mesh, dependent on the properties of the geotextile selected for use. If wire or plastic mesh is used, fasten the mesh securely to the up-slope side of the posts with the geotextile fabric up-slope of the mesh.
 7. Mesh support, if used, shall consist of steel wire with a maximum mesh spacing of 2-inches, or a prefabricated polymeric mesh. The strength of the wire or polymeric mesh shall be equivalent to or greater than 180 lbs grab tensile strength. The polymeric mesh must be as resistant to the same level of ultraviolet radiation as the geotextile fabric it supports.
 8. Bury the bottom of the geotextile fabric 4-inches min. below the ground surface. Backfill and tamp soil in place over the buried portion of the geotextile fabric, so that no flow can pass beneath the silt fence and scouring cannot occur. When wire or polymeric back-up support mesh is used, the wire or polymeric mesh shall extend into the ground 3-inches min.
 9. Drive or place the silt fence posts into the ground 18-inches min. A 12-inch min. depth is allowed if topsoil or other soft subgrade soil is not present and 18-inches cannot be reached. Increase fence post min. depths by 6 inches if the fence is located on slopes of 3H:1V or steeper and the slope is perpendicular to the fence. If required post depths cannot be obtained, the posts shall be adequately secured by bracing or guying to prevent overturning of the fence due to sediment loading.

10. Use wood, steel or equivalent posts. The spacing of the support posts shall be a maximum of 6 feet. Posts shall consist of one of the following:
 - Wood with minimum dimensions of 2 inches by 2 inches by 3 feet. Wood shall be free of defects such as knots, splits, or gouges.
 - No. 6 steel rebar or larger.
 - ASTM A 120 steel pipe with a minimum diameter of 1-inch.
 - U, T, L, or C shape steel posts with a minimum weight of 1.35 lbs./ft.
 - Other steel posts having equivalent strength and bending resistance to the post sizes listed above.
 11. Locate silt fences on contour as much as possible, except at the ends of the fence, where the fence shall be turned uphill such that the silt fence captures the runoff water and prevents water from flowing around the end of the fence.
 12. If the fence must cross contours, with the exception of the ends of the fence, place check dams perpendicular to the back of the fence to minimize concentrated flow and erosion. The slope of the fence line where contours must be crossed shall not be steeper than 3H:1V.
 - Check dams shall be approximately 1 foot deep at the back of the fence. Check dams shall be continued perpendicular to the fence at the same elevation until the top of the check dam intercepts the ground surface behind the fence.
 - Check dams shall consist of crushed surfacing base course, gravel backfill for walls, or shoulder ballast. Check dams shall be located every 10 feet along the fence where the fence must cross contours.
- Refer to [Figure II-4.23: Silt Fence Installation by Slicing Method](#) for slicing method details. The following are specifications for silt fence installation using the slicing method:
 1. The base of both end posts must be at least 2 to 4 inches above the top of the geotextile fabric on the middle posts for ditch checks to drain properly. Use a hand level or string level, if necessary, to mark base points before installation.
 2. Install posts 3 to 4 feet apart in critical retention areas and 6 to 7 feet apart in standard applications.
 3. Install posts 24 inches deep on the downstream side of the silt fence, and as close as possible to the geotextile fabric, enabling posts to support the geotextile fabric from upstream water pressure.
 4. Install posts with the nipples facing away from the geotextile fabric.
 5. Attach the geotextile fabric to each post with three ties, all spaced within the top 8 inches of the fabric. Attach each tie diagonally 45 degrees through the fabric, with each puncture at least 1-

inch vertically apart. Each tie should be positioned to hang on a post nipple when tightening to prevent sagging.

6. Wrap approximately 6 inches of the geotextile fabric around the end posts and secure with 3 ties.
7. No more than 24 inches of a 36 inch geotextile fabric is allowed above ground level.
8. Compact the soil immediately next to the geotextile fabric with the front wheel of the tractor, skid steer, or roller exerting at least 60 pounds per square inch. Compact the upstream side first and then each side twice for a total of four trips. Check and correct the silt fence installation for any deviation before compaction. Use a flat-bladed shovel to tuck the fabric deeper into the ground if necessary.

Figure II-4.23: Silt Fence Installation by Slicing Method

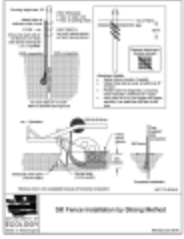

[Download PDF](#)

Maintenance Standards

- Repair any damage immediately.
- Intercept and convey all evident concentrated flows uphill of the silt fence to a sediment trapping BMP.
- Check the uphill side of the silt fence for signs of the fence clogging and acting as a barrier to flow and then causing channelization of flows parallel to the fence. If this occurs, replace the fence and remove the trapped sediment.
- Remove sediment deposits when the deposit reaches approximately one-third the height of the silt fence, or install a second silt fence.
- Replace geotextile fabric that has deteriorated due to ultraviolet breakdown.

Washington State Department of Ecology

2024 Stormwater Management Manual for Western Washington (2024 SWMMWW)

Publication No. 24-10-013

BMP C234: Vegetated Strip

Purpose

Vegetated strips reduce the transport of coarse sediment from a construction site by providing a physical barrier to sediment and reducing the runoff velocities of overland flow.

Conditions of Use

- Vegetated strips may be used downslope of all disturbed areas.
- Vegetated strips are not intended to treat concentrated flows, nor are they intended to treat substantial amounts of overland flow. Any concentrated flows must be conveyed through the drainage system to [BMP C241: Sediment Pond \(Temporary\)](#) or other sediment trapping BMP. The only circumstance in which overland flow can be treated solely by a vegetated strip, rather than by a sediment trapping BMP, is when the following criteria are met (see [Table II-4.13: Contributing Drainage Area for Vegetated Strips](#)):

Table II-4.13: Contributing Drainage Area for Vegetated Strips

Average Contributing Area Slope	Average Contributing Area Percent Slope	Maximum Contributing Area Flowpath Length
1.5H : 1V or flatter	67% or flatter	100 feet
2H : 1V or flatter	50% or flatter	115 feet
4H : 1V or flatter	25% or flatter	150 feet
6H : 1V or flatter	16.7% or flatter	200 feet
10H : 1V or flatter	10% or flatter	250 feet

Design and Installation Specifications

- The vegetated strip shall consist of a continuous strip of dense vegetation with topsoil for a minimum length of 25 feet along the flow path. Grass-covered, landscaped areas are generally not adequate because the volume of sediment overwhelms the grass. Ideally, vegetated strips shall consist of undisturbed native growth with a well-developed soil that allows for infiltration of runoff.
- The slope within the vegetated strip shall not exceed 4H:1V.

- The uphill boundary of the vegetated strip shall be delineated with clearing limits.

Maintenance Standards

- Any areas damaged by erosion or construction activity shall be seeded immediately and protected by mulch.
- If more than 5 feet of the original vegetated strip width has had vegetation removed or is being eroded, sod must be installed.
- If there are indications that concentrated flows are traveling across the vegetated strip, stormwater runoff controls must be installed to reduce the flows entering the vegetated strip, or additional perimeter protection must be installed.

Washington State Department of Ecology

2024 Stormwater Management Manual for Western Washington (2024 SWMMWW)

Publication No. 24-10-013

BMP C235: Wattles

Purpose

Wattles are temporary erosion and sediment control barriers consisting of straw, compost, or other material that is wrapped in netting made of natural plant fiber or similar encasing material. They reduce the velocity and can spread the flow of rill and sheet runoff, and can capture and retain sediment.

Conditions of Use

- Use wattles:
 - In disturbed areas that require immediate erosion protection.
 - On exposed soils during the period of short construction delays, or over winter months.
 - On slopes requiring stabilization until permanent vegetation can be established.
- The material used dictates the effectiveness period of the wattle. Generally, wattles are effective for one to two seasons.
- Prevent rilling beneath wattles by entrenching and overlapping wattles to prevent water from passing between them.

Design Criteria

- Wattles shall consist of cylinders of plant material such as weed-free straw, coir, wood chips, excelsior, or wood fiber or shavings encased within netting made of natural plant fibers unaltered by synthetic materials.
- See [Figure II-4.24: Wattles](#) for typical construction details.
- Wattles are typically 8 to 10 inches in diameter and 25 to 30 feet in length.
- Install wattles perpendicular to the flow direction and parallel to the slope contour.
- Place wattles in shallow trenches, staked along the contour of disturbed or newly constructed slopes. Dig narrow trenches across the slope (on contour) to a depth of 3 to 5 inches on clay soils and soils with gradual slopes. On loose soils, steep slopes, and areas with high rainfall, the trenches should be dug to a depth of 5 to 7 inches, or 1/2 to 2/3 of the thickness of the wattle.

- Start building trenches and installing wattles from the base of the slope and work up. Spread excavated material evenly along the uphill slope and compact it using hand tamping or other methods.
- Construct trenches at intervals of 10 to 25 feet depending on the steepness of the slope, soil type, and rainfall. The steeper the slope the closer together the trenches.
- Install the wattles snugly into the trenches and overlap the ends of adjacent wattles 12 inches behind one another.
- Install stakes at each end of the wattle, and at 4 foot centers along entire length of wattle.
- If required, install pilot holes for the stakes using a straight bar to drive holes through the wattle and into the soil.
- Wooden stakes should be approximately 0.75 x 0.75 x 24 inches minimum. Willow cuttings or 3/8 inch rebar can also be used for stakes.
- Stakes should be driven through the middle of the wattle, leaving 2 to 3 inches of the stake protruding above the wattle.

Figure II-4.24: Wattles

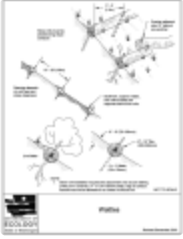

[Download PDF](#)

Maintenance Standards

- Wattles may require maintenance to ensure they are in contact with soil and thoroughly entrenched, especially after significant rainfall on steep sandy soils.
- Inspect the slope after significant storms and repair any areas where wattles are not tightly abutted or water has scoured beneath the wattles.

Approved as Functionally Equivalent

Ecology has approved products as able to meet the requirements of this BMP. The products did not pass through the Technology Assessment Protocol – Ecology (TAPE) process. Local jurisdictions may choose not to accept these products, or may require additional testing prior to consideration for local use. Products that Ecology has approved as functionally equivalent are available for review on Ecology’s website at:

<https://ecology.wa.gov/Regulations-Permits/Guidance-technical-assistance/Stormwater-permittee-guidance-resources/Emerging-stormwater-treatment-technologies>

Washington State Department of Ecology

2024 Stormwater Management Manual for Western Washington (2024 SWMMWW)

Publication No. 24-10-013

BMP C236: Vegetative Filtration

Purpose

Vegetative filtration as a BMP is used in conjunction with detention storage in the form of portable tanks or [BMP C241: Sediment Pond \(Temporary\)](#), [BMP C206: Level Spreader](#), and a pumping system with surface intake. Vegetative filtration improves turbidity levels of stormwater discharges by filtering runoff through existing vegetation where undisturbed forest floor duff layer or established lawn with thatch layer are present. Vegetative filtration can also be used to infiltrate dewatering waste from foundations, vaults, and trenches as long as runoff does not occur.

Conditions of Use

- For every 5 acres of disturbed soil, use 1 acre of grass field, farm pasture, or wooded area. Reduce or increase this area depending on project size, groundwater table height, and other site conditions.
- Wetlands shall not be used for vegetative filtration.
- Do not use this BMP in areas with a high groundwater table, or in areas that will have a high seasonal groundwater table during the use of this BMP.
- This BMP may be less effective on soils that prevent the infiltration of the water, such as hard till.
- Using other effective source control measures throughout a construction site will prevent the generation of additional highly turbid water and may reduce the time period or area need for this BMP.
- Stop distributing water into the vegetated filtration area if standing water or erosion results.
- On large projects that phase the clearing of the site, areas retained with native vegetation may be used as a temporary vegetative filtration area.

Design Criteria

- Find land adjacent to the project site that has a vegetated field, preferably a farm field or wooded area.
- If the site does not contain enough vegetated field area consider obtaining permission from adjacent landowners (especially for farm fields).
- Install a pump and downstream distribution manifold depending on the project size. Generally, the main distribution line should reach 100 to 200 feet long. Large projects, or projects on tight soil, will require systems that reach several thousand feet long with numerous branch lines off of the main distribution line.

- The manifold should have several valves, allowing for control over the distribution area in the field.
- Install several branches of 4 inch diameter schedule 20 polyvinyl chloride (PVC), swaged-fit common septic tight-lined sewer line, or 6 inch diameter fire hose, which can convey the turbid water out to various sections of the field. See [Figure II-4.25: Manifold and Branches in a Wooded, Vegetated Spray Field](#).
- Determine the branch length based on the field area geography and number of branches. Typically, branches stretch from 200 feet to several thousand feet. Lay the branches on contour with the slope.
- On uneven ground, sprinklers perform well. Space sprinkler heads so that spray patterns do not overlap.
- On relatively even surfaces, a level spreader using 4 inch diameter perforated pipe may be used as an alternative option to the sprinkler head setup. Install drain pipe at the highest point on the field and at various lower elevations to ensure full coverage of the filtration area. Place the pipe with the holes up to allow for gentle weeping evenly out all holes. Leveling the pipe by staking and using sandbags may be required.
- To prevent over saturating of the vegetative filtration area, rotate the use of branches or spray heads. Repeat as needed based on monitoring of the spray field.

Table II-4.14: Flowpath Guidelines for Vegetative Filtration

Average Slope	Average Area % Slope	Estimated Flowpath Length (ft)
1.5H:1V	67%	250
2H:1V	50%	200
4H:1V	25%	150
6H:1V	16.7%	115
10H:1V	10%	100

Figure II-4.25: Manifold and Branches in a Wooded, Vegetated Spray Field



[Download PDF](#)

Maintenance Standards

- Monitor the spray field on a daily basis to ensure that over saturation of any portion of the field does not occur at any time. The presence of standing puddles of water or creation of concentrated flows visually signify that over saturation of the field has occurred.
- Monitor the vegetated spray field all the way down to the nearest surface water, or farthest spray area, to ensure that the water has not caused overland or concentrated flows, and has not created erosion around the spray nozzle(s).
- Do not exceed water quality standards for turbidity.
- Ecology recommends that a separate inspection log be developed, maintained, and kept with the existing site logbook to aid the operator conducting inspections. This separate “Field Filtration Logbook” can also aid in demonstrating compliance with permit conditions.
- Inspect the spray nozzles daily, at a minimum, for leaks and plugging from sediment particles.
- If erosion, concentrated flows, or over saturation of the field occurs, rotate the use of branches or spray heads or move the branches to a new field location.
- Check all branches and the manifold for unintended leaks.

Washington State Department of Ecology

2024 Stormwater Management Manual for Western Washington (2024 SWMMWW)

Publication No. 24-10-013

BMP C240: Sediment Trap

Purpose

A sediment trap is a small temporary ponding area with a gravel outlet used to collect and store sediment from sites during construction. Sediment traps, along with other perimeter controls, shall be installed before any land disturbance takes place in the contributing drainage area.

Conditions of Use

- Sediment traps are intended for use on sites where the contributing drainage area is less than 3 acres, with no unusual drainage features, and a projected build-out time of 6 months or less. The sediment trap is a temporary measure (with a design life of approximately 6 months) and shall be maintained until the contributing drainage area is permanently protected against erosion by vegetation and/or structures.
- Sediment traps are only effective in removing sediment down to about the medium silt size fraction. Runoff with sediment of finer grades (fine silt and clay) will pass through untreated, emphasizing the need to control erosion to the maximum extent first.
- Projects that are constructing permanent Flow Control BMPs, or permanent Runoff Treatment BMPs that use ponding for treatment, may use the rough-graded or final-graded permanent BMP footprint for the temporary sediment trap. When permanent BMP footprints are used as temporary sediment traps, the surface area requirement of the sediment trap must be met. If the surface area requirement of the sediment trap is larger than the surface area of the permanent BMP, then the sediment trap shall be enlarged beyond the permanent BMP footprint to comply with the surface area requirement.
- A floating pond skimmer may be used for the sediment trap outlet if approved by the Local Permitting Authority.
- Sediment traps may not be feasible on utility projects due to the limited work space or the short-term nature of the work. Portable tanks may be used in place of sediment traps for utility projects.

Design and Installation Specifications

- See [Figure II-4.26: Cross Section of Sediment Trap](#) and [Figure II-4.27: Sediment Trap Outlet](#) for details.
- To determine the sediment trap geometry, first calculate the design surface area (SA) of the trap, measured at the invert of the weir. Use the following equation:

$$SA = FS * (Q_2/V_s)$$

where:

SA = Design surface area of the trap (square feet)

FS = A safety factor of 2 to account for non-ideal settling.

Q₂ = The peak volumetric flow rate (cubic feet per second), calculated using one of the following options:

o Option 1 - Single Event Hydrograph Method

The peak volumetric flow rate calculated using a 10-minute time step from a Type 1A, 2-year, 24-hour frequency storm for the developed condition. The 10-year peak volumetric flow rate shall be used if the project size, expected timing and duration of construction, or downstream conditions warrant a higher level of protection.

o Option 2 - The Rational Method

For construction sites that are less than 1 acre, the peak volumetric flow rate calculated using the Rational Method.

V_s = The settling velocity of the soil particle of interest. The 0.02 mm (medium silt) particle with an assumed density of 2.65 g/cm³ has been selected as the particle of interest and has a settling velocity (V_s) of 0.00096 ft/sec.

Therefore, the equation for computing sediment trap surface area becomes:

$$SA = 2 \times Q_2 / 0.00096$$

or

2080 square feet per cfs of inflow

- Sediment trap depth shall be 3.5 feet minimum from the bottom of the trap to the top of the overflow weir.
- To aid in determining sediment depth, all sediment traps shall have a staff gauge with a prominent mark 1 foot above the bottom of the trap.
- Design the discharge from the sediment trap by using the guidance for discharge from temporary sediment ponds in [BMP C241: Sediment Pond \(Temporary\)](#).

Maintenance Standards

- Sediment shall be removed from the trap when it reaches 1 foot in depth.
- Any damage to the trap embankments or slopes shall be repaired.

Figure II-4.26: Cross Section of Sediment Trap



[Download PDF](#)

Figure II-4.27: Sediment Trap Outlet

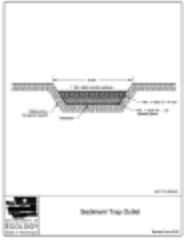

[Download PDF](#)

Washington State Department of Ecology

2024 Stormwater Management Manual for Western Washington (2024 SWMMWW)

Publication No. 24-10-013

BMP C250: Construction Stormwater Chemical Treatment

Purpose

This BMP applies when using chemicals to treat turbidity in stormwater by either batch or flow-through chemical treatment.

Turbidity is difficult to control once fine particles are suspended in stormwater runoff from a construction site. [BMP C241: Sediment Pond \(Temporary\)](#) is effective at removing larger particulate matter by gravity settling, but is ineffective at removing smaller particulates such as clay and fine silt. Traditional Construction Stormwater BMPs may not be adequate to ensure compliance with the water quality standards for turbidity in the receiving water.

Chemical treatment can reliably provide exceptional reductions of turbidity and associated pollutants. Chemical treatment may be required to meet turbidity stormwater discharge requirements, especially when construction proceeds through the wet season.

Conditions of Use

Formal written approval from Ecology is required for the use of chemical treatment, regardless of site size. See Ecology's Request for Chemical Treatment form at the following web address:

<https://fortress.wa.gov/ecy/publications/SummaryPages/ecy070258.html>

The Local Permitting Authority may also require review and approval. When authorized, the chemical treatment systems must be included in the Construction Stormwater Pollution Prevention Plan (SWPPP).

Chemically treated stormwater discharged from construction sites must be nontoxic to aquatic organisms. The Chemical Technology Assessment Protocol - Ecology (CTAPE) must be used to evaluate chemicals proposed for stormwater treatment. Only chemicals approved by Ecology under the CTAPE may be used for stormwater treatment. The approved chemicals, their allowable application techniques (batch treatment or flow-through treatment), allowable application rates, and conditions of use can be found at Ecology's Emerging Technologies website:

<https://ecology.wa.gov/Regulations-Permits/Guidance-technical-assistance/Stormwater-permittee-guidance-resources/Emerging-stormwater-treatment-technologies>

Background on Chemical Treatment Systems

Coagulation and flocculation have been used for over a century to treat water. The use of coagulation and flocculation to treat stormwater is a very recent application. Experience with the treatment of water and

wastewater has resulted in a basic understanding of the process, in particular factors that affect performance. This experience can provide insights as to how to most effectively design and operate similar systems in the treatment of stormwater.

Fine particles suspended in water give it a milky appearance, measured as *turbidity*. Their small size, often much less than 1 micron (μm) in diameter, give them a very large surface area relative to their volume. These fine particles typically carry a negative surface charge. Largely because of these two factors (small size and negative charge), these particles tend to stay in suspension for extended periods of time. Thus, removal is not practical by gravity settling. These are called stable suspensions. Chemicals like polymers, as well as inorganic chemicals such as alum, speed the settling process. The added chemical destabilizes the suspension and causes the smaller particles to flocculate. The process consists of three primary steps: *coagulation*, *flocculation*, and settling or *clarification*. Ecology requires a fourth step, *filtration*, on all stormwater chemical treatment systems to reduce floc discharge and to provide monitoring prior to discharge.

General Design and Installation Specifications

- Chemicals approved for use in Washington State are listed on Ecology's TAPE website, under the "Construction" tab, at the following web address:

<http://www.ecy.wa.gov/programs/wq/stormwater/newtech/technologies.html>

- Care must be taken in the design of the withdrawal system to minimize outflow velocities and to prevent floc discharge. Stormwater that has been chemically treated must be filtered through [BMP C251: Construction Stormwater Filtration](#) for filtration and monitoring prior to discharge.
- System discharge rates must take into account downstream conveyance integrity.
- The following equipment should be located on site in a lockable shed:
 - The chemical injector.
 - Secondary containment for acid, caustic, buffering compound, and treatment chemical.
 - Emergency shower and eyewash.
 - Monitoring equipment which consists of a pH meter and a turbidimeter.
- There are two types of systems for applying the chemical treatment process to stormwater: the batch chemical treatment system and the flow-through chemical treatment system. See below for further details for both types of systems.

Batch Chemical Treatment Systems

A batch chemical treatment system consists of four steps: *coagulation*, *flocculation*, *clarification*, and polishing and monitoring via *filtration*.

Step 1: Coagulation

Coagulation is the process by which negative charges on the fine particles are disrupted. By disrupting the negative charges, the fine particles are able to flocculate. Chemical addition is one method of destabilizing the suspension, and polymers are one class of chemicals that are generally effective. Chemicals that are used for this purpose are called coagulants. Coagulation is complete when the suspension is destabilized by the neutralization of the negative charges. Coagulants perform best when they are thoroughly and evenly dispersed under relatively intense mixing. This rapid mixing involves adding the coagulant in a manner that promotes rapid dispersion, followed by a short time period for destabilization of the particle suspension. The particles are still very small and are not readily separated by clarification until flocculation occurs.

Step 2: Flocculation

Flocculation is the process by which fine particles that have been destabilized bind together to form larger particles that settle rapidly. Flocculation begins naturally following coagulation, but is enhanced by gentle mixing of the destabilized suspension. Gentle mixing helps to bring particles in contact with one another such that they bind and continually grow to form "flocs". As the size of the flocs increase, they become heavier and settle.

Step 3: Clarification

The final step is the settling of the particles, or clarification. Particle density, size and shape are important during settling. Dense, compact flocs settle more readily than less dense, fluffy flocs. Because of this, flocculation to form dense, compact flocs is particularly important during chemical treatment. Water temperature is important during settling. Both the density and viscosity of water are affected by temperature; these in turn affect settling. Cold temperatures increase viscosity and density, thus slowing down the rate at which the particles settle.

The conditions under which clarification is achieved can affect performance. Currents can affect settling. Currents can be produced by wind, by differences between the temperature of the incoming water and the water in the clarifier, and by flow conditions near the inlets and outlets. Quiescent water, such as that which occurs during batch clarification, provides a good environment for settling. One source of currents in batch chemical treatment systems is movement of the water leaving the clarifier unit. Because flocs are relatively small and light, the velocity of the water must be as low as possible. Settled flocs can be resuspended and removed by fairly modest currents.

Step 4: Filtration

After clarification, Ecology requires stormwater that has been chemically treated to be filtered and monitored prior to discharge. The sand filtration system continually monitors the stormwater effluent for turbidity and pH. If the discharge water is ever out of an acceptable range for turbidity or pH, the water is returned to the untreated stormwater pond where it will begin the treatment process again.

Design and Installation of Batch Chemical Treatment Systems

A batch chemical treatment system consists of a stormwater collection system (either a temporary diversion or the permanent site drainage system), an untreated stormwater storage pond, pumps, a chemical feed system, treatment cells, a filtering and monitoring system, and interconnecting piping.

The batch treatment system uses a storage pond for untreated stormwater, followed by a minimum of two lined treatment cells. Multiple treatment cells allow for clarification of chemically treated water in one cell, while other

cells are being filled or emptied. Treatment cells may be ponds or tanks.

Ponds that can impound 10 acre-feet or more are subject to the Washington Dam Safety Regulations ([Chapter 173-175 WAC](#)). See [BMP D.1: Detention Ponds](#) for more information regarding dam safety considerations for ponds.

Stormwater is collected at interception point(s) on the site and is diverted by gravity or by pumping to an untreated stormwater storage pond or other untreated stormwater holding area. The stormwater is stored until treatment occurs. It is important that the storage pond is large enough to provide adequate storage.

The first step in the treatment sequence is to check the pH of the stormwater in the untreated stormwater storage pond. The pH is adjusted by the application of carbon dioxide or a base until the stormwater in the untreated storage pond is within the desired pH range, 6.5 to 8.5. When used, carbon dioxide is added immediately downstream of the transfer pump. Typically sodium bicarbonate (baking soda) is used as a base, although other bases may be used. When needed, base is added directly to the untreated stormwater storage pond. The stormwater is recirculated with the treatment pump to provide mixing in the storage pond. Initial pH adjustments should be based on daily bench tests. Further pH adjustments can be made at any point in the process. See [BMP C252: Treating and Disposing of High pH Water](#) for more information on pH adjustments as a part of chemical treatment.

Once the stormwater is within the desired pH range (which is dependent on the coagulant being used), the stormwater is pumped from the untreated stormwater storage pond to a lined treatment cell as a coagulant is added. The coagulant is added upstream of the pump to facilitate rapid mixing.

The water is kept in the lined treatment cell for clarification. In a batch mode process, clarification typically takes from 30 minutes to several hours. Prior to discharge, samples are withdrawn for analysis of pH, coagulant concentration, and turbidity. If these levels are acceptable, the treated water is withdrawn, filtered, and discharged.

Several configurations have been developed to withdraw treated water from the treatment cell. The original configuration is a device that withdraws the treated water from just beneath the water surface using a float with adjustable struts that prevent the float from settling on the cell bottom. This reduces the possibility of picking up floc from the bottom of the cell. The struts are usually set at a minimum clearance of about 12 inches; that is, the float will come within 12 inches of the bottom of the cell. Other systems have used vertical guides or cables which constrain the float, allowing it to drift up and down with the water level. More recent designs have an H-shaped array of pipes, set on the horizontal. This scheme provides for withdrawal from four points rather than one. This configuration reduces the likelihood of sucking settled solids from the bottom. It also reduces the tendency for a vortex to form. Inlet diffusers, a long floating or fixed pipe with many small holes in it, are also an option.

Safety is a primary concern. Design should consider the hazards associated with operations, such as sampling. Facilities should be designed to reduce slip hazards and drowning. Tanks and ponds should have life rings, ladders, or steps extending from the bottom to the top.

Sizing Batch Chemical Treatment Systems

Chemical treatment systems must be designed to control the velocity and peak volumetric flow rate that is discharged from the system and consequently the project site. See [II-2.3 Element 3: Control Flow Rates](#) for further

details on this requirement.

The total volume of the untreated stormwater storage pond and treatment cell(s) must be large enough to treat stormwater that is produced during multiple day storm events. It is recommended that at a minimum the untreated stormwater storage pond be sized to hold 1.5 times the volume of runoff generated from the site during the 10-year, 24-hour storm event. Bypass should be provided around the chemical treatment system to accommodate extreme storm events. Runoff volume shall be calculated using the methods presented in [III-2.3 Single Event Hydrograph Method](#). Worst-case land cover conditions (i.e., producing the most runoff) should be used for analyses (in most cases, this would be the land cover conditions just prior to final landscaping).

Primary settling should be encouraged in the untreated stormwater storage pond. A forebay with access for maintenance may be beneficial.

There are two opposing considerations in sizing the treatment cells. A larger cell is able to treat a larger volume of water each time a batch is processed. However, the larger the cell, the longer the time required to empty the cell. A larger cell may also be less effective at flocculation and therefore require a longer settling time. The simplest approach to sizing the treatment cell is to multiply the allowable discharge flow rate (as determined by the guidance in [II-2.3 Element 3: Control Flow Rates](#)) times the desired drawdown time. A 4 hour drawdown time allows one batch per cell per 8 hour work period, given 1 hour of flocculation followed by 2 hours of settling.

See [BMP C251: Construction Stormwater Filtration](#) for details on sizing the filtration system at the end of the batch chemical treatment system.

If the chemical treatment system design does not allow you to discharge at the rates as required by [II-2.3 Element 3: Control Flow Rates](#), and if the site has a permanent Flow Control BMP that will serve the planned development, the discharge from the chemical treatment system may be directed to the permanent Flow Control BMP to comply with [II-2.3 Element 3: Control Flow Rates](#). In this case, all discharge (including water passing through the treatment system and stormwater bypassing the treatment system) will be directed into the permanent Flow Control BMP. If site constraints make locating the untreated stormwater storage pond difficult, the permanent Flow Control BMP may be divided to serve as the untreated stormwater storage pond and the post-treatment temporary flow control pond. A berm or barrier must be used in this case so the untreated water does not mix with the treated water. Both untreated stormwater storage requirements, and adequate post-treatment flow control must be achieved. The designer must document in the Construction SWPPP how the permanent Flow Control BMP is able to attenuate the discharge from the site to meet the requirements of [II-2.3 Element 3: Control Flow Rates](#). If the design of the permanent Flow Control BMP was modified for temporary construction flow control purposes, the construction of the permanent Flow Control BMP must be finalized, as designed for its permanent function, at project completion.

Flow-Through Chemical Treatment Systems

Background on Flow-Through Chemical Treatment Systems

A flow-through chemical treatment system adds a sand filtration component to the batch chemical treatment system's treatment train following flocculation. The coagulant is added to the stormwater upstream of the sand filter so that the coagulation and flocculation step occur immediately prior to the filter. The advantage of a flow-

through chemical treatment system is the time saved by immediately filtering the water, as opposed to waiting for the clarification process necessary in a batch chemical treatment system. See [BMP C251: Construction Stormwater Filtration](#) for more information on filtration.

Design and Installation of Flow-Through Chemical Treatment Systems

At a minimum, a flow-through chemical treatment system consists of a stormwater collection system (either a temporary diversion or the permanent site drainage system), an untreated stormwater storage pond, and a chemically enhanced sand filtration system.

As with a batch treatment system, stormwater is collected at interception point(s) on the site and is diverted by gravity or by pumping to an untreated stormwater storage pond or other untreated stormwater holding area. The stormwater is stored until treatment occurs. It is important that the holding pond be large enough to provide adequate storage.

Stormwater is then pumped from the untreated stormwater storage pond to the chemically enhanced sand filtration system where a coagulant is added. Adjustments to pH may be necessary before coagulant addition. The sand filtration system continually monitors the stormwater effluent for turbidity and pH. If the discharge water is ever out of an acceptable range for turbidity or pH, the water is returned to the untreated stormwater pond where it will begin the treatment process again.

Sizing Flow-Through Chemical Treatment Systems

Refer to [BMP C251: Construction Stormwater Filtration](#) for sizing requirements of flow-through chemical treatment systems.

Factors Affecting the Chemical Treatment Process

Coagulants

Cationic polymers can be used as coagulants to destabilize negatively charged turbidity particles present in natural waters, wastewater and stormwater. Polymers are large organic molecules that are made up of subunits linked together in a chain-like structure. Attached to these chain-like structures are other groups that carry positive or negative charges, or have no charge. Polymers that carry groups with positive charges are called cationic, those with negative charges are called anionic, and those with no charge (neutral) are called nonionic. In practice, the only way to determine whether a polymer is effective for a specific application is to perform preliminary or on-site testing.

Aluminum sulfate (alum) can also be used as a coagulant, as this chemical becomes positively charged when dispersed in water.

Polymers are available as powders, concentrated liquids, and emulsions (which appear as milky liquids). The latter are petroleum based, which are not allowed for construction stormwater treatment. Polymer effectiveness can degrade with time and also from other influences. Thus, manufacturers' recommendations for storage should be followed. Manufacturer's recommendations usually do not provide assurance of water quality protection or

safety to aquatic organisms. Consideration of water quality protection is necessary in the selection and use of all polymers.

Application

Application of coagulants at the appropriate concentration or dosage rate for optimum turbidity removal is important for management of chemical cost, for effective performance, and to avoid aquatic toxicity. The optimum dose in a given application depends on several site-specific features. Turbidity of untreated water can be important with turbidities greater than 5,000 NTU. The surface charge of particles to be removed is also important. Environmental factors that can influence dosage rate are water temperature, pH, and the presence of constituents that consume or otherwise affect coagulant effectiveness. Laboratory experiments indicate that mixing previously settled sediment (floc sludge) with the untreated stormwater significantly improves clarification, therefore reducing the effective dosage rate. Preparation of working solutions and thorough dispersal of coagulants in water to be treated is also important to establish the appropriate dosage rate.

For a given water sample, there is generally an optimum dosage rate that yields the lowest residual turbidity after settling. When dosage rates below this optimum value (underdosing) are applied, there is an insufficient quantity of coagulant to react with, and therefore destabilize, all of the turbidity present. The result is residual turbidity (after flocculation and settling) that is higher than with the optimum dose. Overdosing, application of dosage rates greater than the optimum value, can also negatively impact performance. Like underdosing, the result of overdosing is higher residual turbidity than that with the optimum dose.

Mixing

The G-value, or just "G", is often used as a measure of the mixing intensity applied during coagulation and flocculation. The symbol G stands for "velocity gradient", which is related in part to the degree of turbulence generated during mixing. High G-values mean high turbulence, and vice versa.

High G-values provide the best conditions for coagulant addition. With high G's, turbulence is high and coagulants are rapidly dispersed to their appropriate concentrations for effective destabilization of particle suspensions.

Low G-values provide the best conditions for flocculation. Here, the goal is to promote formation of dense, compact flocs that will settle readily. Low G's provide low turbulence to promote particle collisions so that flocs can form. Low G's generate sufficient turbulence such that collisions are effective in floc formation, but do not break up flocs that have already formed.

pH Adjustment

The pH must be in the proper range for the coagulants to be effective, which is typically 6.5 to 8.5. As polymers tend to lower the pH, it is important that the stormwater have sufficient buffering capacity. Buffering capacity is a function of alkalinity. Without sufficient alkalinity, the application of the polymer may lower the pH to below 6.5. A pH below 6.5 not only reduces the effectiveness of the polymer as a coagulant, but it may also create a toxic condition for aquatic organisms. Stormwater may not be discharged without readjustment of the pH to above 6.5. The target pH should be within 0.2 standard units of the receiving water's pH.

Experience gained at several projects in the City of Redmond has shown that the alkalinity needs to be at least 50 mg/L to prevent a drop in pH to below 6.5 when the polymer is added.

Maintenance Standards

Monitoring

At a minimum, the following monitoring shall be conducted. Test results shall be recorded on a daily log kept on site. Additional testing may be required by the NPDES permit based on site conditions.

- Operational Monitoring
 - Total volume treated and discharged.
 - Flow must be continuously monitored and recorded at not greater than 15-minute intervals.
 - Type and amount of chemical used for pH adjustment.
 - Type and amount of coagulant used for treatment.
 - Settling time.
- Compliance Monitoring
 - Influent and effluent pH, flocculent chemical concentration, and turbidity must be continuously monitored and recorded at not greater than 15-minute intervals.
 - pH and turbidity of the receiving water.
- Biomonitoring
 - Treated stormwater must be non-toxic to aquatic organisms. Treated stormwater must be tested for aquatic toxicity or residual chemicals. Frequency of biomonitoring will be determined by Ecology.
 - Residual chemical tests must be approved by Ecology prior to their use.
 - If testing treated stormwater for aquatic toxicity, you must test for acute (lethal) toxicity. Bioassays shall be conducted by a laboratory accredited by Ecology, unless otherwise approved by Ecology. Acute toxicity tests shall be conducted per the CTAPE protocol and Appendix G of *Whole Effluent Toxicity Testing Guidance and Test Review Criteria* ([Marshall, 2016](#)).

Discharge Compliance

Prior to discharge, treated stormwater must be sampled and tested for compliance with pH, flocculent chemical concentration, and turbidity limits. These limits may be established by the Construction Stormwater General Permit or a site-specific discharge permit. Sampling and testing for other pollutants may also be necessary at some sites. pH must be within the range of 6.5 to 8.5 standard units and not cause a change in the pH of the receiving water by more than 0.2 standard units. Treated stormwater samples and measurements shall be taken

from the discharge pipe or another location representative of the nature of the treated stormwater discharge. Samples used for determining compliance with the water quality standards in the receiving water shall not be taken from the treatment pond prior to decanting. Compliance with the water quality standards is determined in the receiving water.

Operator Training

Each project site using chemical treatment must have a trained operator who is certified for operation of an Enhanced Chemical Treatment system. The operator must be trained and certified by an organization approved by Ecology. Organizations approved for operator training are found at the following web address:

<https://ecology.wa.gov/Regulations-Permits/Guidance-technical-assistance/Stormwater-permittee-guidance-resources/Contaminated-water-on-construction-sites>

Sediment Removal and Disposal

- Sediment shall be removed from the untreated stormwater storage pond and treatment cells as necessary. Typically, sediment removal is required at least once during a wet season and at the decommissioning of the chemical treatment system. Sediment remaining in the cells between batches may enhance the settling process and reduce the required chemical dosage.
- Sediment that is known to be non-toxic may be incorporated into the site away from drainages.

Washington State Department of Ecology

2024 Stormwater Management Manual for Western Washington (2024 SWMMWW)

Publication No. 24-10-013

BMP C251: Construction Stormwater Filtration

Purpose

Filtration removes sediment from runoff originating from disturbed areas of the site.

Conditions of Use

Traditional Construction Stormwater BMPs used to control soil erosion and sediment loss from construction sites may not be adequate to ensure compliance with the water quality standard for turbidity in the receiving water. Filtration may be used in conjunction with gravity settling to remove sediment as small as fine silt (0.5 µm). The reduction in turbidity will be dependent on the particle size distribution of the sediment in the stormwater. In some circumstances, sedimentation and filtration may achieve compliance with the water quality standard for turbidity.

The use of construction stormwater filtration does not require approval from Ecology as long as treatment chemicals are not used. Filtration in conjunction with [BMP C250: Construction Stormwater Chemical Treatment](#) requires testing under the Chemical Technology Assessment Protocol – Ecology (CTAPE) before it can be initiated. Approval from Ecology must be obtained at each site where chemical use is proposed prior to use. See Ecology's Request for Chemical Treatment form at the following web address:

<https://fortress.wa.gov/ecy/publications/SummaryPages/ecy070258.html>

Design and Installation Specifications

Two types of filtration systems may be applied to construction stormwater treatment: rapid and slow.

Rapid filtration systems are the typical system used for water and wastewater treatment. They can achieve relatively high hydraulic flow rates, on the order of 2 to 20 gpm/sf, because they have automatic backwash systems to remove accumulated solids.

Slow filtration systems have very low hydraulic rates, on the order of 0.02 gpm/sf, because they do not have backwash systems. Slow filtration systems have generally been used as post construction BMPs to treat stormwater (see [V-7 Filtration BMPs](#)). Slow filtration is mechanically simple in comparison to rapid filtration, but requires a much larger filter area.

Filter Types and Efficiencies

Sand media filters are available with automatic backwashing features that can filter to 50 µm particle size. Screen or bag filters can filter down to 5 µm. Fiber wound filters can remove particles down to 0.5 µm. Filters should be

sequenced from the largest to the smallest pore opening. Sediment removal efficiency will be related to particle size distribution in the stormwater.

Treatment Process and Description

Stormwater is collected at interception point(s) on the site and diverted to an untreated stormwater sediment pond or tank for removal of large sediment, and storage of the stormwater before it is treated by the filtration system. In a rapid filtration system, the untreated stormwater is pumped from the pond or tank through the filtration media. Slow filtration systems are designed using gravity to convey water from the pond or tank to and through the filtration media.

Sizing

Filtration treatment systems must be designed to control the velocity and peak volumetric flow rate that is discharged from the system and consequently the project site. See [II-2.3 Element 3: Control Flow Rates](#) for further details on this requirement.

The untreated stormwater storage pond or tank should be sized to hold 1.5 times the volume of runoff generated from the site during the 10-year, 24-hour storm event, minus the filtration treatment system flow rate for an 8-hour period. For a chitosan-enhanced sand filtration system, the filtration treatment system flow rate should be sized using a hydraulic loading rate between 6 and 8 gpm/ft². Other hydraulic loading rates may be more appropriate for other systems. Bypass should be provided around the filtration treatment system to accommodate extreme storm events. Runoff volume shall be calculated using the methods presented in [III-2.3 Single Event Hydrograph Method](#). Worst-case land cover conditions (i.e., producing the most runoff) should be used for analyses (in most cases, this would be the land cover conditions just prior to final landscaping).

If the filtration treatment system design does not allow you to discharge at the rates as required by [II-2.3 Element 3: Control Flow Rates](#), and if the site has a permanent Flow Control BMP that will serve the planned development, the discharge from the filtration treatment system may be directed to the permanent Flow Control BMP to comply with [II-2.3 Element 3: Control Flow Rates](#). In this case, all discharge (including water passing through the treatment system and stormwater bypassing the treatment system) will be directed into the permanent Flow Control BMP. If site constraints make locating the untreated stormwater storage pond difficult, the permanent Flow Control BMP may be divided to serve as the untreated stormwater storage pond and the post-treatment temporary flow control pond. A berm or barrier must be used in this case so the untreated water does not mix with the treated water. Both untreated stormwater storage requirements, and adequate post-treatment flow control must be achieved. The designer must document in the Construction SWPPP how the permanent Flow Control BMP is able to attenuate the discharge from the site to meet the requirements of [II-2.3 Element 3: Control Flow Rates](#). If the design of the permanent Flow Control BMP was modified for temporary construction flow control purposes, the construction of the permanent Flow Control BMP must be finalized, as designed for its permanent function, at project completion.

Maintenance Standards

- Rapid sand filters typically have automatic backwash systems that are triggered by a pre-set pressure drop across the filter. If the backwash water volume is not large or substantially more turbid than the untreated

stormwater stored in the holding pond or tank, backwash return to the untreated stormwater pond or tank may be appropriate. However, other means of treatment and disposal may be necessary.

- Screen, bag, and fiber filters must be cleaned and/or replaced when they become clogged.
- Sediment shall be removed from the storage and/or treatment ponds as necessary. Typically, sediment removal is required once or twice during a wet season and at the decommissioning of the ponds.
- Disposal of filtration equipment must comply with applicable local, state, and federal regulations.

Washington State Department of Ecology

2024 Stormwater Management Manual for Western Washington (2024 SWMMWW)

Publication No. 24-10-013

BMP C252: Treating and Disposing of High pH Water

Purpose

When pH levels in stormwater rise above 8.5, it is necessary to lower the pH levels to the acceptable range of 6.5 to 8.5 prior to discharge to surface or groundwater. A pH level range of 6.5 to 8.5 is typical for most natural watercourses, and this neutral pH range is required for the survival of aquatic organisms. Should the pH rise or drop out of this range, fish and other aquatic organisms may become stressed and may die.

Conditions of Use

- The water quality standard for pH in Washington State is in the range of 6.5 to 8.5. Stormwater with pH levels exceeding water quality standards may be either neutralized on site or disposed of to a sanitary sewer or concrete batch plant with pH neutralization capabilities.
- Neutralized stormwater may be discharged to surface waters under the Construction Stormwater General Permit.
- Passive percolation of a limited volume of pH-affected stormwater is acceptable, with the understanding it does not “pond” or result in runoff from the project boundary or to waters of the state. Any visible accumulations of such water must be considered pH-affected and managed to protect waters of the state.

NOTE: this only applies to high pH stormwater or conditionally authorized non-stormwater, it does not apply to process water, which may be subject to numeric effluent limits under certain permits, or otherwise not authorized for discharge to waters of the state.

- Neutralized process water such as concrete truck washout, hydrodemolition, or sawcutting slurry must be managed to prevent discharge to surface waters. Any stormwater contaminated during concrete work is considered process wastewater and must not be discharged to waters of the State or stormwater collection systems.
- The process used for neutralizing and/or disposing of high pH stormwater from the site must be documented in the Construction SWPPP.
- There are other options for neutralizing or managing high pH stormwater beyond what Ecology provides formal guidance on. Regardless of the stormwater management methods selected, the resulting pH-affected stormwater must be managed in a way that meets permit conditions for discharge.

NOTE: If the proposed option to neutralize high-pH stormwater involves a chemical treatment beyond what is described in this BMP, additional authorization for the chemical treatment may be necessary.

Causes of High pH

High pH at construction sites is most commonly caused by the contact of stormwater with poured or recycled concrete, cement, mortars, and other Portland cement or lime containing construction materials. See [BMP C151: Concrete Handling](#) for more information on concrete handling procedures. The principal caustic agent in cement is calcium hydroxide (free lime).

Calcium hardness can contribute to high pH values and cause toxicity that is associated with high pH conditions. A high level of calcium hardness in waters of the state is not allowed. Groundwater standard for calcium and other dissolved solids in Washington State is less than 500 mg/l.

Treating High pH Stormwater by Carbon Dioxide Sparging

Advantages of Carbon Dioxide Sparging

- Rapidly neutralizes high pH water.
- Cost effective and safer to handle than acid compounds.
- CO₂ is self-buffering. It is difficult to overdose and create harmfully low pH levels.
- Material is readily available.

The Chemical Process of Carbon Dioxide Sparging

When carbon dioxide (CO₂) is added to water (H₂O), carbonic acid (H₂CO₃) is formed which can further dissociate into a proton (H⁺) and a bicarbonate anion (HCO₃⁻) as shown below:



The free proton is a weak acid that can lower the pH. Water temperature has an effect on the reaction as well. The colder the water temperature is, the slower the reaction occurs. The warmer the water temperature is, the quicker the reaction occurs. Most construction applications in Washington State have water temperatures in the 50°F or higher range so the reaction is almost simultaneous.

The Treatment Process of Carbon Dioxide Sparging

High pH water may be treated using continuous treatment, continuous discharge systems. These manufactured systems continuously monitor influent and effluent pH to ensure that pH values are within an acceptable range before being discharged. All systems must have fail safe automatic shut off switches in the event that pH is not within the acceptable discharge range. Only trained operators may operate manufactured systems. System manufacturers often provide trained operators or training on their devices.

The following procedure may be used when not using a continuous discharge system:

1. Prior to treatment, the appropriate jurisdiction should be notified in accordance with the regulations set by the jurisdiction.
2. Every effort should be made to isolate the potential high pH water in order to treat it separately from other stormwater on-site.
3. Water should be stored in an acceptable storage facility, detention pond, or containment cell prior to pH treatment.
4. Transfer water to be treated for pH to the pH treatment structure. Ensure that the pH treatment structure size is sufficient to hold the amount of water that is to be treated. Do not fill the pH treatment structure completely, allow at least 2 feet of freeboard.
5. The operator samples the water within the pH treatment structure for pH and notes the clarity of the water. As a rule of thumb, less CO₂ is necessary for clearer water. The results of the samples and water clarity observations should be recorded.
6. In the pH treatment structure, add CO₂ until the pH falls into the range of 6.9 to 7.1. Adjusting pH to within 0.2 pH units of receiving water (background pH) is recommended. It is unlikely that pH can be adjusted to within 0.2 pH units using dry ice. Compressed carbon dioxide gas should be introduced to the water using a carbon dioxide diffuser located near the bottom of the pH treatment structure, this will allow carbon dioxide to bubble up through the water and diffuse more evenly.
7. Slowly discharge the water, making sure water does not get stirred up in the process. Release about 80% of the water from the pH treatment structure leaving any sludge behind. If turbidity remains above the maximum allowable, consider adding filtration to the treatment train. See [BMP C251: Construction Stormwater Filtration](#).
8. Discharge treated water through a pond or drainage system.
9. Excess sludge needs to be disposed of properly as concrete waste. If several batches of water are undergoing pH treatment, sludge can be left in the treatment structure for the next batch treatment. Dispose of sludge when it fills 50% of the treatment structure volume.
10. Disposal must comply with applicable local, state, and federal regulations.

Treating High pH Stormwater by Food Grade Vinegar

Food grade vinegar that meets FDA standards may be used to neutralize high pH water. Food grade vinegar is only 4% to 18% acetic acid with the remainder being water. Food grade vinegar may be used if dosed just enough to lower pH sufficiently. Use a treatment process as described above for CO₂ sparging, but add food grade vinegar instead of CO₂.

This treatment option for high pH stormwater does not apply to anything but food grade vinegar. Acetic acid does not equal vinegar. Any other product or waste containing acetic acid must go through the evaluation process in Appendix G of *Whole Effluent Toxicity Testing Guidance and Test Review Criteria* ([Marshall, 2016](#)).

Disposal of High pH Stormwater

Sanitary Sewer Disposal

Local sewer authority approval is required prior to disposal via the sanitary sewer.

Concrete Batch Plant Disposal

- Only permitted facilities may accept high pH water.
- Contact the facility to ensure they can accept the high pH water.

Maintenance Standards

Safety and materials handling:

- All equipment should be handled in accordance with OSHA rules and regulations.
- Follow manufacturer guidelines for materials handling.

Each operator should provide:

- A diagram of the monitoring and treatment equipment.
- A description of the pumping rates and capacity the treatment equipment is capable of treating.

Each operator should keep a written record of the following:

- Client name and phone number.
- Date of treatment.
- Weather conditions.
- Project name and location.
- Volume of water treated.
- pH of untreated water.
- Amount of CO₂ or food grade vinegar needed to adjust water to a pH range of 6.9 to 7.1.
- pH of treated water.
- Discharge point location and description.

A copy of this record should be given to the client/contractor who should retain the record for 3 years.

If required, drape filter fabric over brush and secure in 4"x4" min. trench with compacted backfill

Flow direction

Anchor downhill edge of filter fabric with stakes, sandbags, or equivalent

2' min. height

Min. 5' wide brush barrier with max. 6" diameter woody debris. Alternatively topsoil strippings may be used to form the barrier.

NOT TO SCALE



DEPARTMENT OF
ECOLOGY
State of Washington

Brush Barrier

Revised July 2017

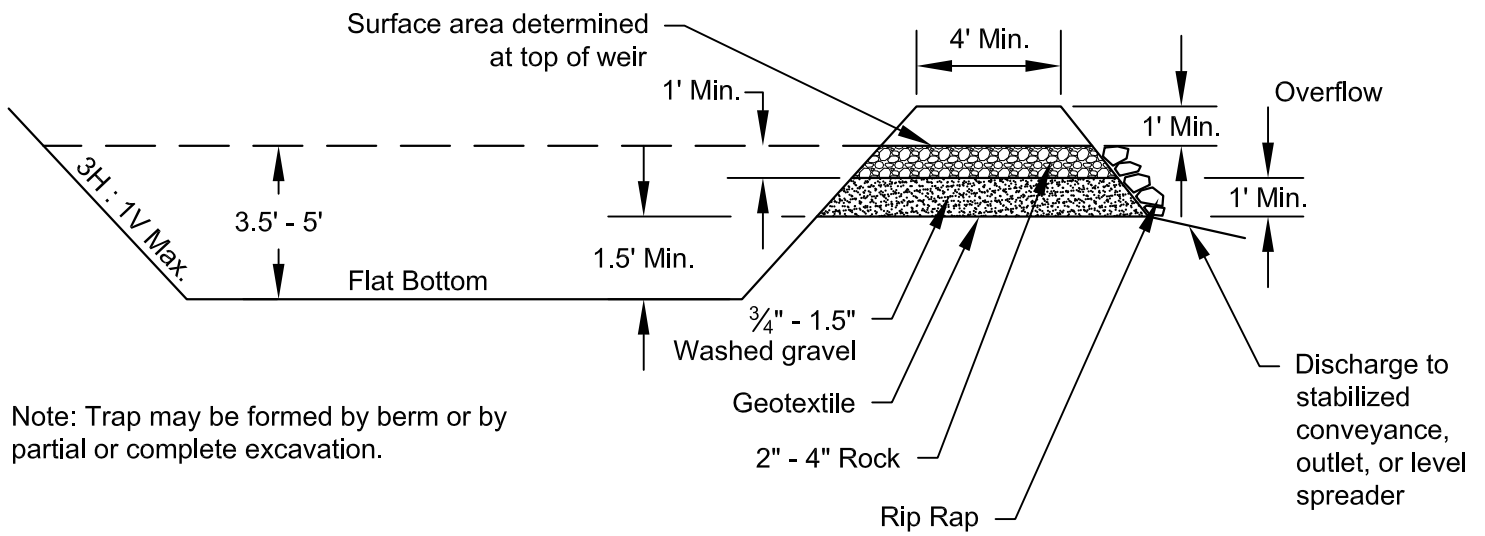

Note: Trap may be formed by berm or by partial or complete excavation.

NOT TO SCALE



DEPARTMENT OF
ECOLOGY
State of Washington

Cross Section of Sediment Trap

Revised June 2016

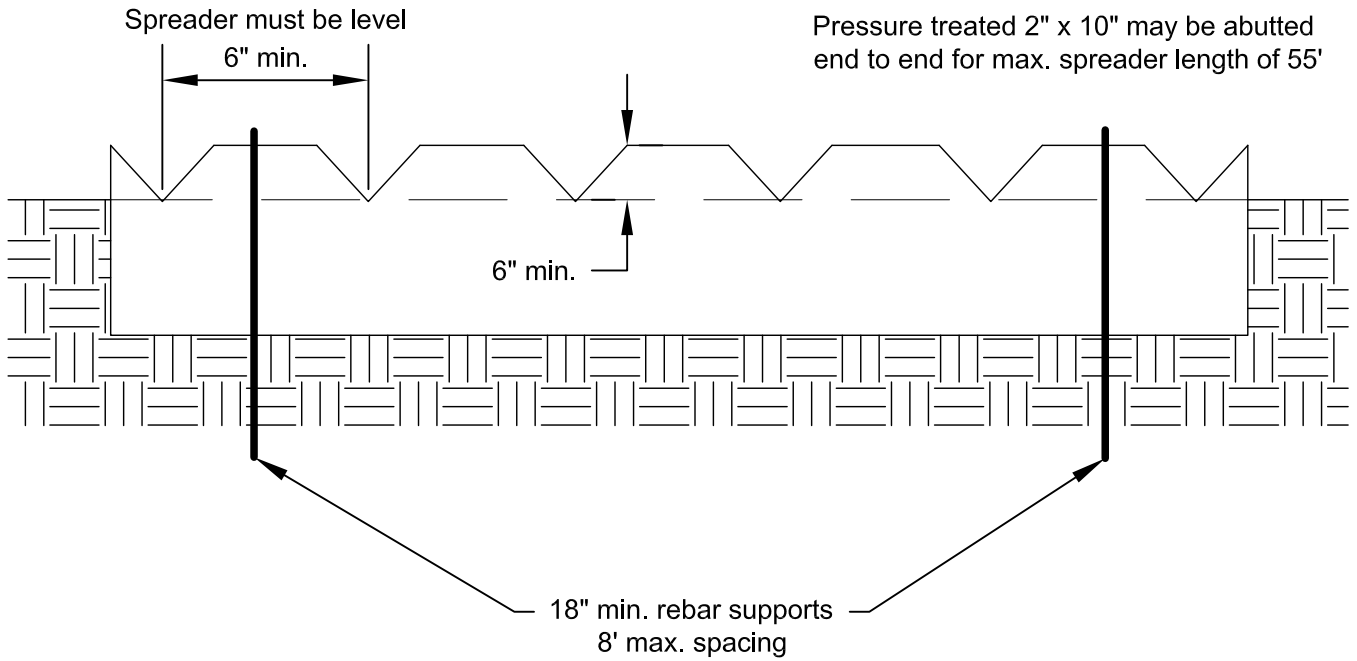

NOT TO SCALE



DEPARTMENT OF
ECOLOGY
State of Washington

Detail of Level Spreader

Revised July 2017

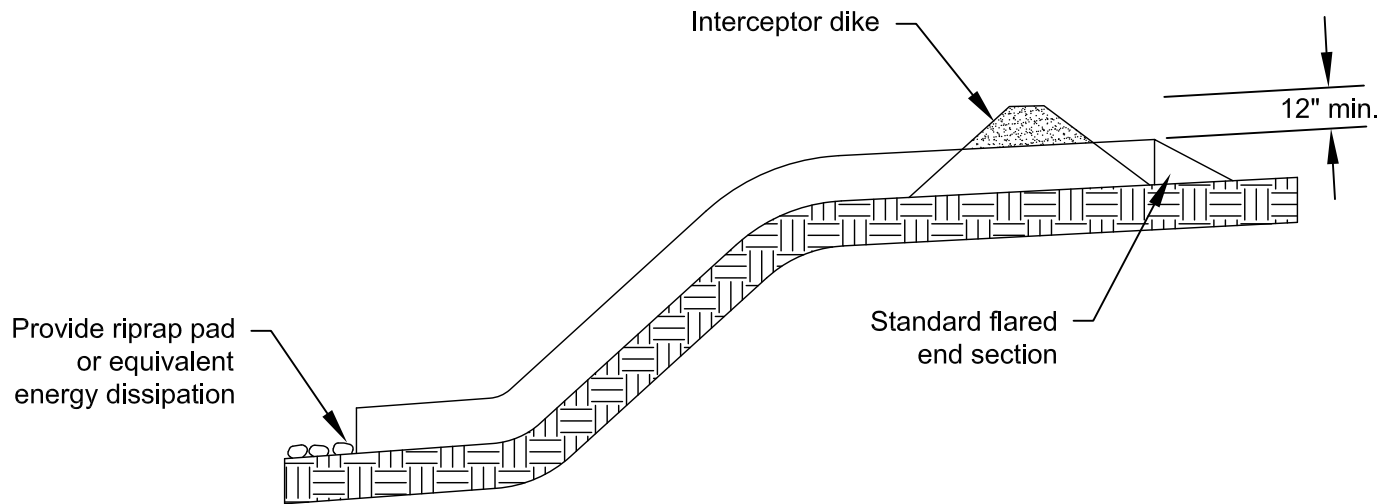
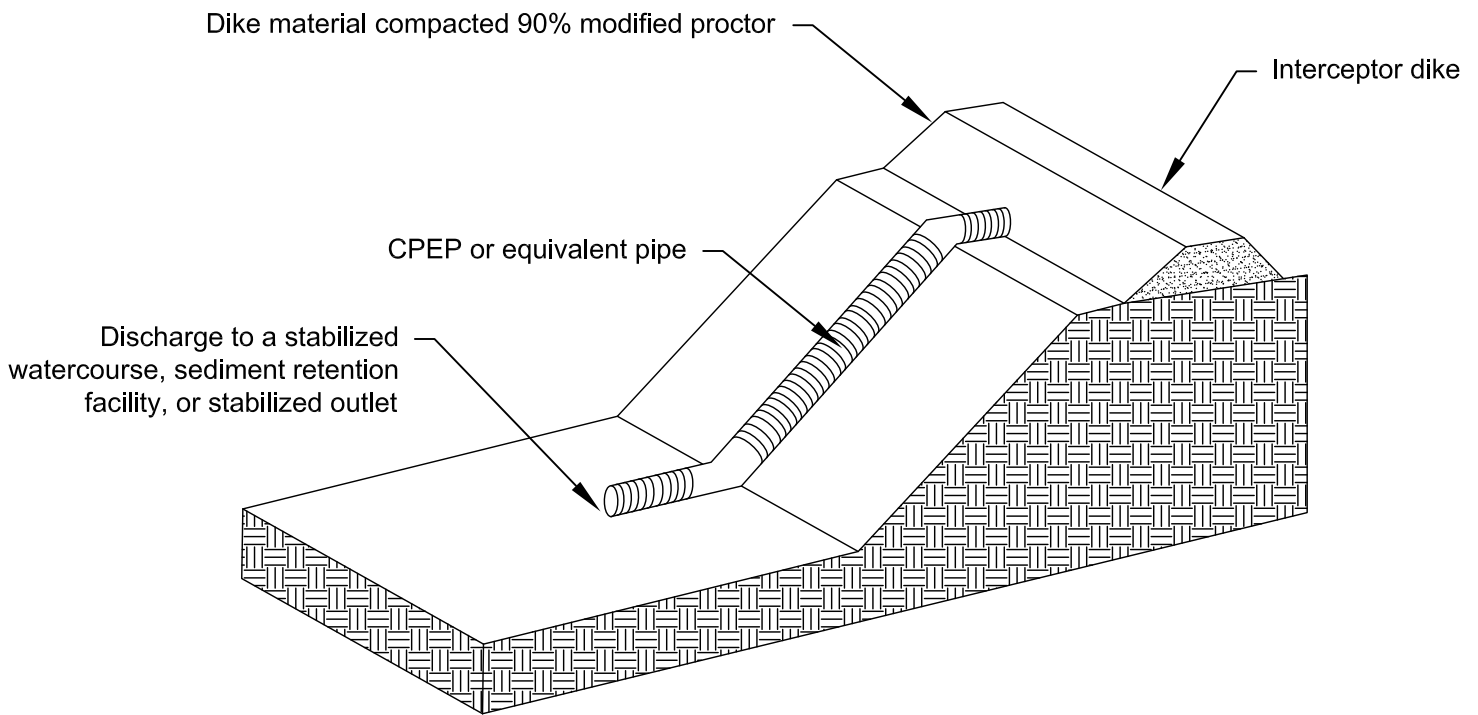

Notes:

1. Inlet and all sections must be securely fastened together with gasketed watertight fittings

NOT TO SCALE



DEPARTMENT OF
ECOLOGY
State of Washington

Pipe Slope Drain

Revised June 2016

View Looking Upstream

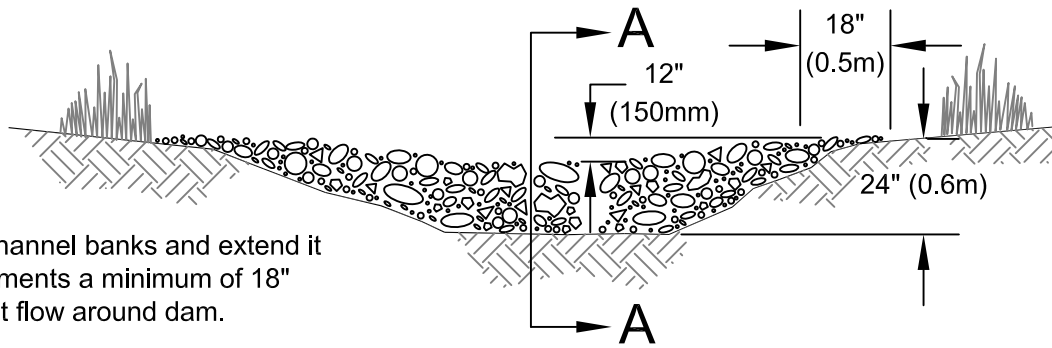

Note:
Key stone into channel banks and extend it beyond the abutments a minimum of 18" (0.5m) to prevent flow around dam.

Section A-A

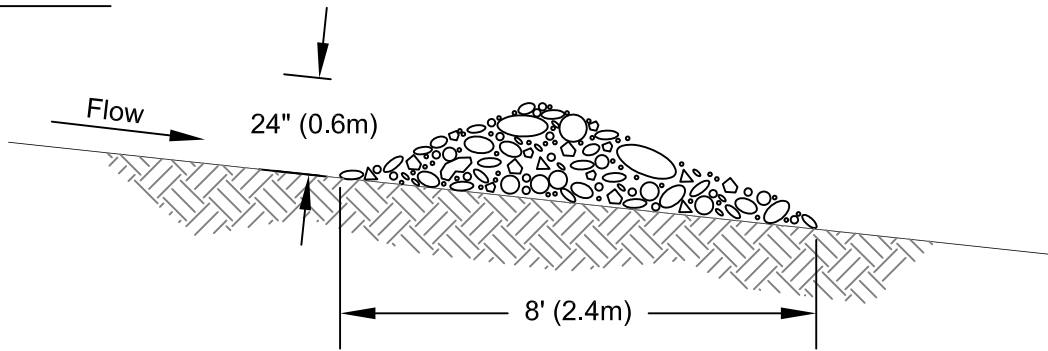

Spacing Between Check Dams

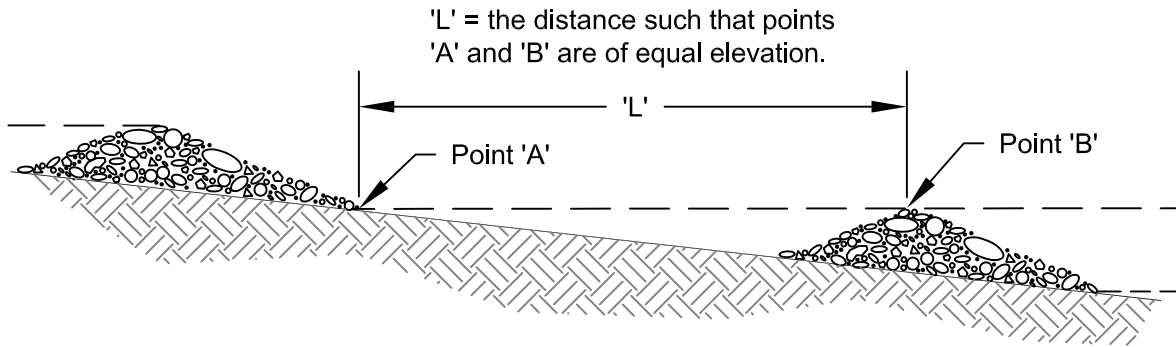

NOT TO SCALE



DEPARTMENT OF
ECOLOGY
State of Washington

Rock Check Dam

Revised June 2016

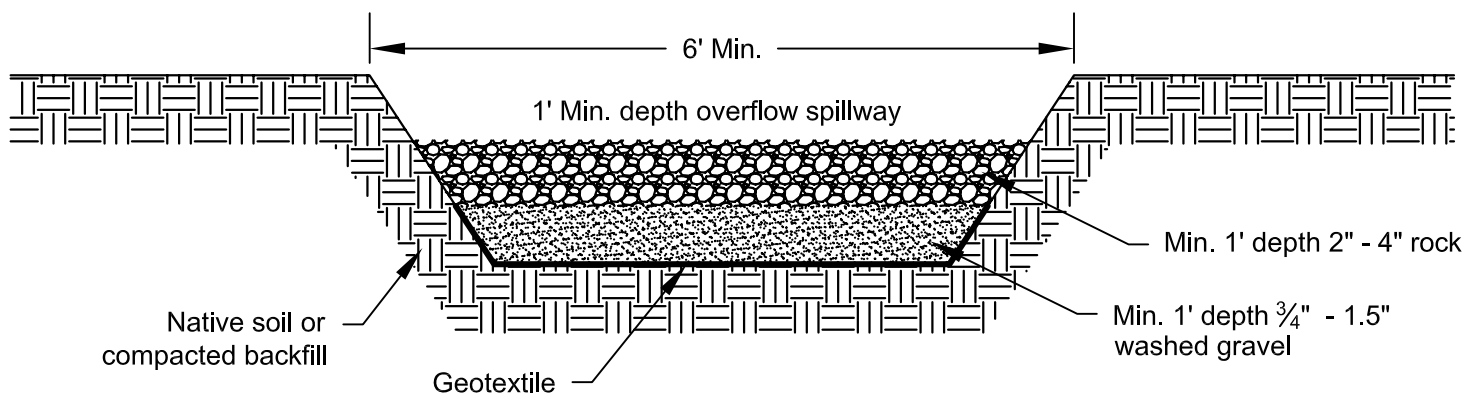

NOT TO SCALE



DEPARTMENT OF
ECOLOGY
 State of Washington

Sediment Trap Outlet

Revised June 2016

Typical V-Shaped Channel Cross-Section

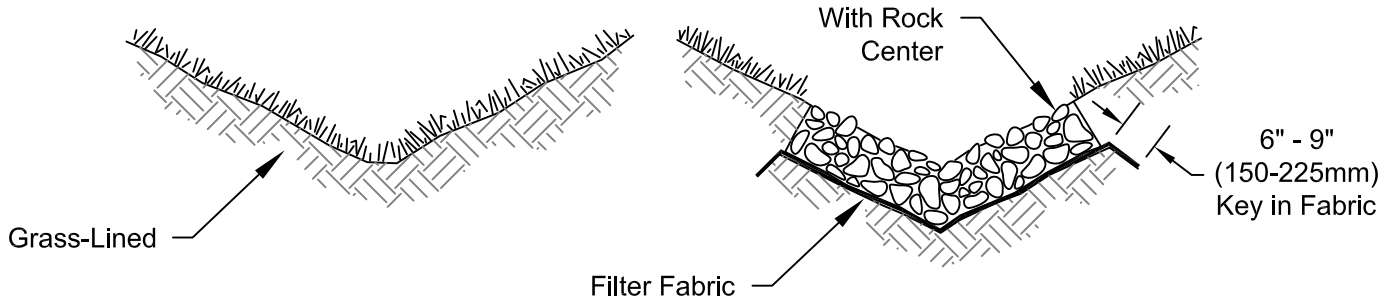

Typical Parabolic Channel Cross-Section

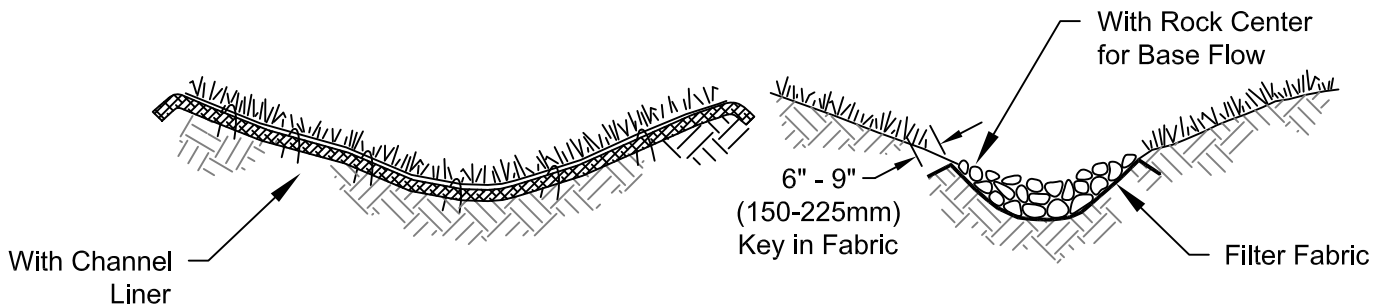

Typical Trapezoidal Channel Cross-Section

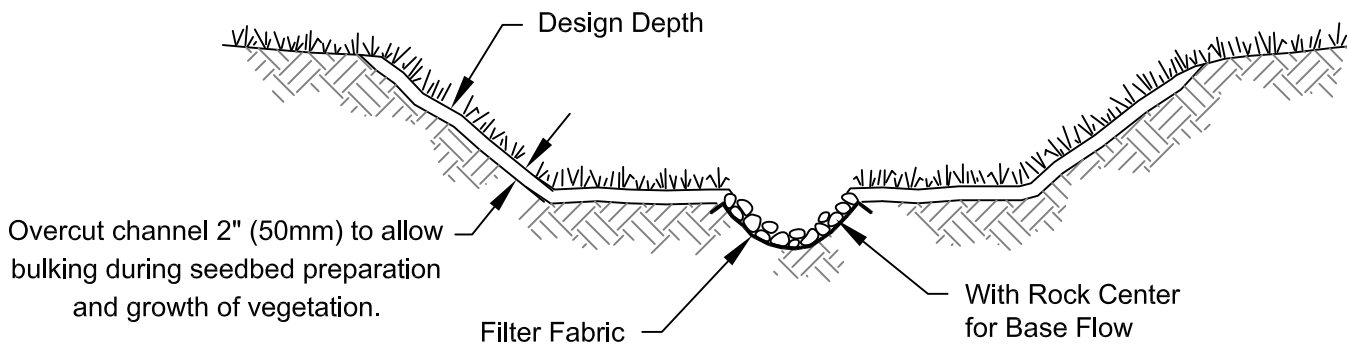

NOT TO SCALE



DEPARTMENT OF
ECOLOGY
State of Washington

Typical Grass-Lined Channels

Revised June 2016

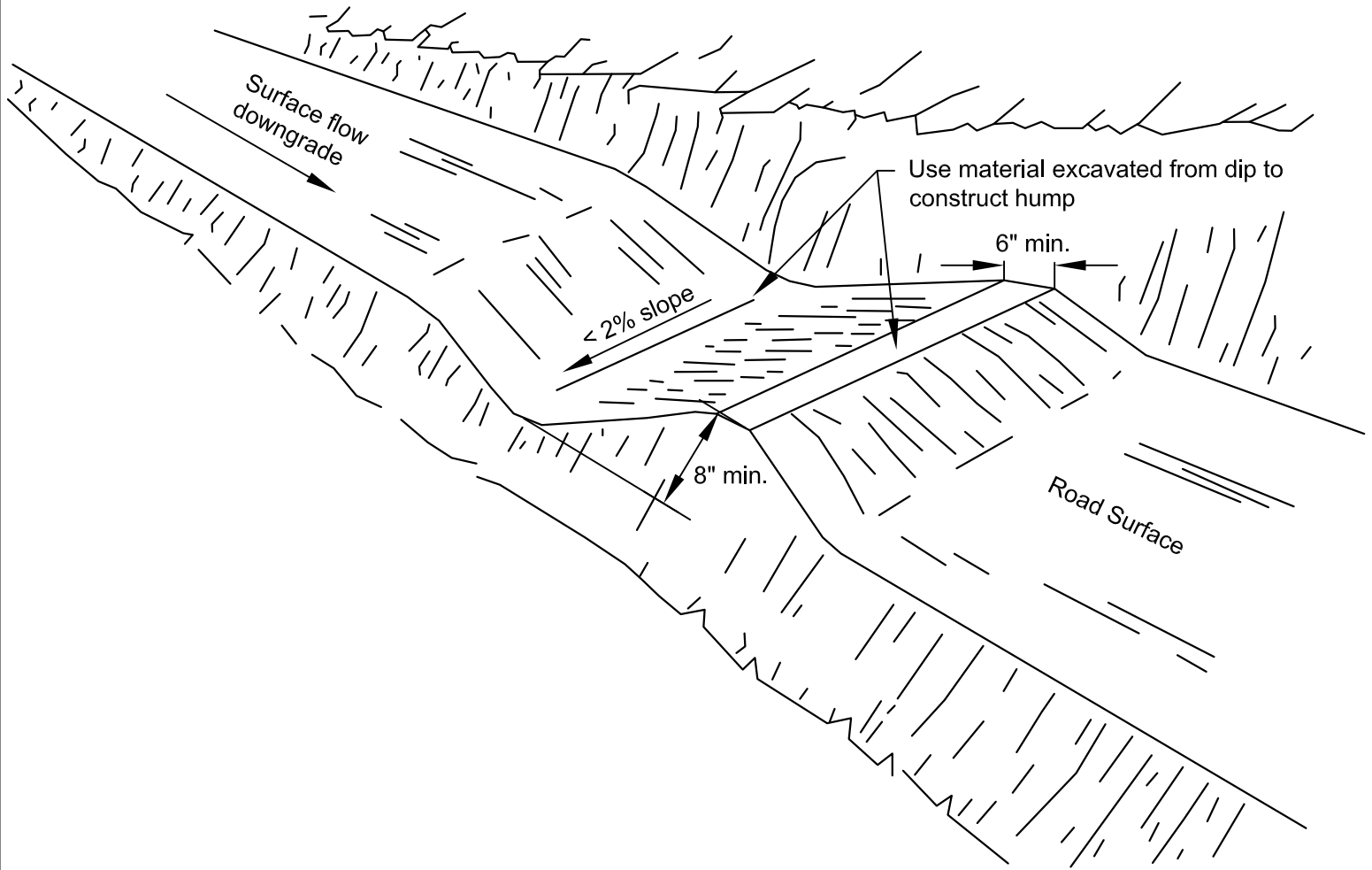

NOT TO SCALE



DEPARTMENT OF
ECOLOGY
State of Washington

Water Bar

Revised July 2017

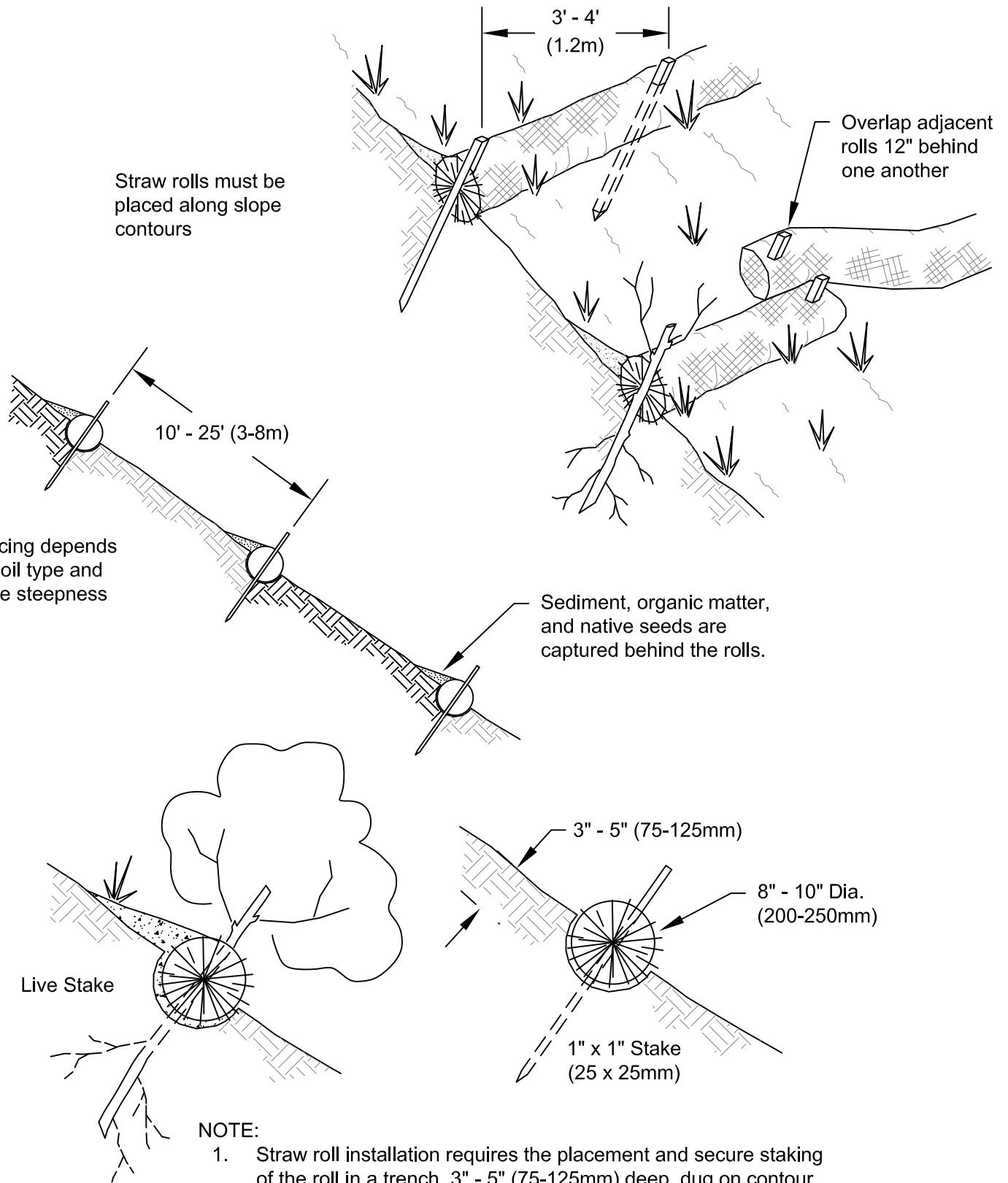

NOT TO SCALE

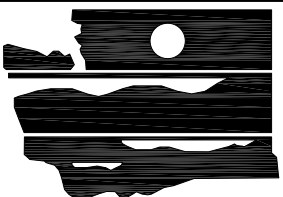

DEPARTMENT OF
ECOLOGY
State of Washington

Wattles

Revised December 2016